

L. SEVERANCE.

Machine for Making Bolts.

No. 268.

Patented July 11, 1837.

Fig. 1.

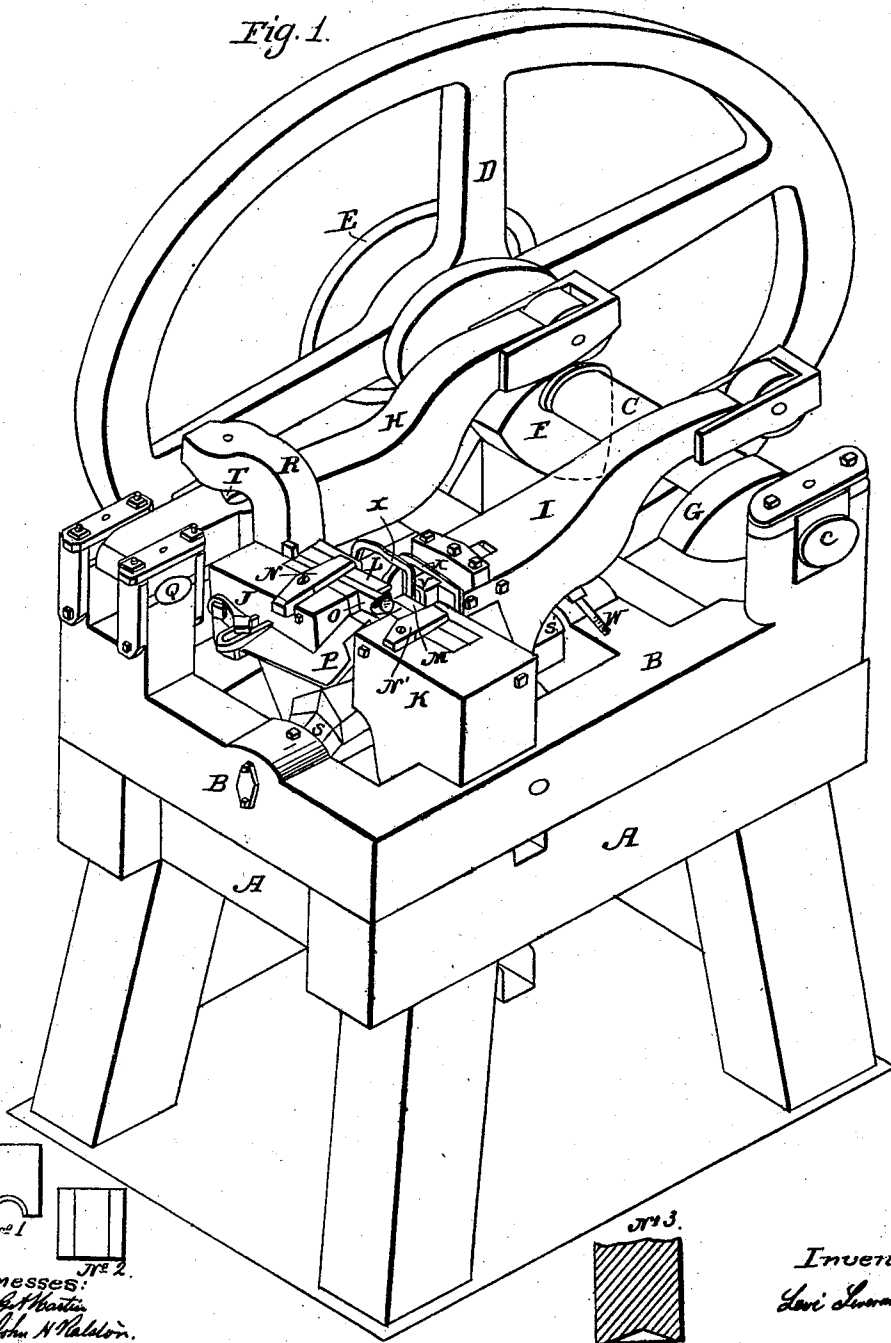

Witnesses:
J^{no} 1.
J^{no} 2.
J. H. Martin
John H. Mallon.

Inventor:
Levi Severance

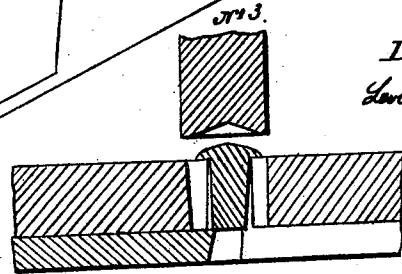

UNITED STATES PATENT OFFICE.

LEVI SEVERANCE, OF PITTSBURGH, PENNSYLVANIA.

MACHINE FOR MAKING RIVETS FOR RIVETING STEAM-BOILERS AND OTHER ARTICLES—APPLICABLE TO OTHER PURPOSES.

Specification of Letters Patent No. 268, dated July 11, 1837.

To all whom it may concern:

Be it known that I, LEVI SEVERANCE, of Pittsburgh, in the county of Allegheny and State of Pennsylvania, have invented a new and useful Machine for Making Rivets of Iron or other Metal, for Riveting Steam-Boilers or other Articles, which machine I also intend to apply to the manufacturing of railroad pins, spikes, and other rivets and pins in which a rounding-head is required or where it is desired that the shank should be larger immediately under the head than toward the point; and I do hereby declare that the following is a full and exact description thereof.

The drawing shows the whole machine in perspective, together with sectional views of such parts as it was thought useful so to represent. The perspective view is reduced to about one fourth the size of an ordinary machine; the parts in section, the full size of such as I have used. It is made, in part, of cast, and in part of wrought-iron, the cutters and dies being of steel.

A, A, represents a stout bench, which sustains the basis, or main frame, B, B, of the machine.

C, C, is the main shaft, through the medium of which the moving parts of the machine are operated upon. It has on it a fly-wheel D, and a whirl E, by which it may be driven, both being placed at the outside of the frame. Within the frame, it carries two cams F, and G, acting, respectively, upon the two levers H, and I. The lever H, which is raised by the cam F, gives motion to the movable jaw of the machine; and the lever I, which is raised by the cam G, carries the heading die, which, as its name indicates, performs the operation of heading. J, is the movable, and K the fixed, jaw of the machine; on the upper side of each of these jaws, I make a score, or excavation, sufficiently large to receive the largest gripping dies which I intend to use. These gripping dies are marked L, and M, and are held in their places by the caps and screws N, N'; they are shown in section in Nos. 1, 2, and 3, in the drawing. The gripping dies are alike in form, each of them receiving in a score, or excavation, made for that purpose, one half of the rivet, or other article; for round rivets, the concavity in each is a semi-cylinder, or rather half the frustum of a cone, as the rivets are usu-

ally made tapering, being about a sixteenth of an inch larger immediately under the heads, than they are at the points. The length and form of these excavations must, necessarily, be governed by the length and form to be given to the rivet, or other article. In the movable jaw there is also a cutting die, O, which stands in advance of the gripping die, to a distance equal to the diameter of the rivet to be made, as it serves not only to cut off the rod to a proper length for a rivet, but to sustain its points during the operation of heading.

The operation of the gripping and cutting apparatus will now be readily understood. The rod to be cut and headed, is fed in by advancing it upon the guide plate, P, which is so placed as to conduct it immediately between the gripping dies; the rod is prevented from passing too far in, by coming into contact with the heading die. The shaft C, in its revolution, brings the cam F, against the end of the lever H, and raises it, closing the jaws, and consequently cutting off and gripping the piece to be headed. Both the levers have friction rollers on their ends, to relieve the action of the cams. The cam F, is made sufficiently long on its face to hold the piece during the operation of heading; the face being a segment of a circle, of which the axis of C, is the center. The lever H, has its fulcrum at Q, and in rising it raises R, which is a part of the movable jaw. One end of the axis of this jaw is seen at S, and the other at S'. T, is a joint piece between H and R, made hemispherical at its ends, and fitting into corresponding cavities, in which it works freely, and with little friction.

At the moment when the gripping dies have taken firm hold of the piece, the cam G, comes into contact with the heading lever I, and raises it. The axis of this lever straddles across the axis of H, the point U, designating one of its fulcra.

V, is the heading die, firmly fixed into the head of the lever. There is a regulating screw W, under this lever, which determines the portion of the rod taken to form the head. X, X, are clearers, which, as the jaws open, come into contact with the head of the rivet, and insure its removal from the dies.

In using this machine, when the rivets of five eighths of an inch in diameter are to be

made, I use iron of nine sixteenths, and so of other sizes, the pressure in heading serving to fill up the taper of the dies, which, as before remarked, is, generally, one sixteenth of an inch. When the rivets are made of iron, the rods are heated to redness, and in this case I use my dies without hardening, as, if hardened, they are liable to crack and fly, from the effect of the heat; a stream of cold water is kept running upon them, to prevent their being unduly heated.

With a machine thus constructed, and driven by any suitable power, from ten to fifteen hundred weight of rivets may be made in a day, the labor being performed by two boys, one to heat the rods, and the other to feed them into the machine. The rivets thus made are superior to those produced in any other known way.

What I claim as my invention, and desire to secure by Letters Patent, is—

The manner in which I have combined the respective parts of the within described cutting and heading machine, for the manu-

facturing of rivets, and other articles of a similar nature, I do not claim either of the individual parts of my machine, in its separate character; levers, cams, gripping, cutting and heading dies, having been frequently used, but not, as I verily believe, so combined together, for the purposes herein set forth, as to possess that simplicity and efficiency, or to exhibit that general character, by which my machine, as combined, is distinguished. And I do hereby declare that I except the general construction of the heading part, taken alone, from my claim, and that I do not intend to confine myself to any particular dimensions, or form, in constructing my machine, but to vary these as I may think proper, while the principle of action, and the effect produced, are substantially unchanged.

LEVI SEVERANCE.

Witnesses:

JOHN H. RALSTON,
G. A. MARTIN.