

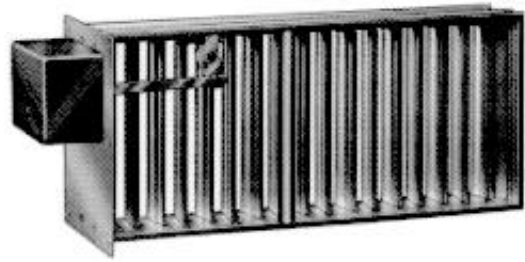

These opposed blade dampers are used in York Zone Control Systems. They are multi-blade dampers that control the flow of conditioned air in rectangular or rigid round air ducts.

- Mounted through the side or bottom of air ducts.
- Located near the furnace plenum.
- When used with central logic panels, zone control dampers remain open when there is no call for conditioned air.
- Controlled by a 24 Vac, 50/60 Hz motor actuator.

2RS267 AND 2RB267 OPPOSED BLADE DAMPERS



Planning the Installation

LOCATION

Zone Control Dampers are installed near the furnace plenum in the air duct takeoff to the zone.

DAMPER SIZE

To ensure proper operation, dampers must be properly sized for the air duct. To ensure proper fit, damper sizes are built slightly smaller than the listed dimensions. If the damper is forced into an undersized air duct, the excess pressure jams the damper blades and causes improper operation.

When a small percentage of continuous air flow is desired in a zone, even when the damper blades are closed, install a damper that is shorter than the air duct width. Refer to Fig. 1.

HUMIDIFICATION

Do not install dampers in heating systems where spray or atomizing type humidifiers are installed in the furnace plenum or air supply duct. Excessive lime or mineral deposits accumulate on damper blades and cause improper operation.

For humidification, use evaporative type humidifiers or return air type humidifiers.

INSTALLATION CONSIDERATIONS

1. Install 2RS267 Opposed Blade Damper and 2RB267 Opposed Blade Damper-Bottom Mount into squared air ducts. Frame misalignment jams damper blades.
2. Applications in air ducts wider than 30 inches require multiple dampers and damper mounting tracks. Refer to Fig. 5.
3. In multiple damper applications, do not weld dampers together.
4. Do not weld dampers to air ducts or damper mounting tracks.

5. When securing dampers with sheet metal screws, refer to Installation instructions. Improper use of sheet metal screws can damage damper blades and electric actuator.

Fig. 1—Installing shorter dampers.

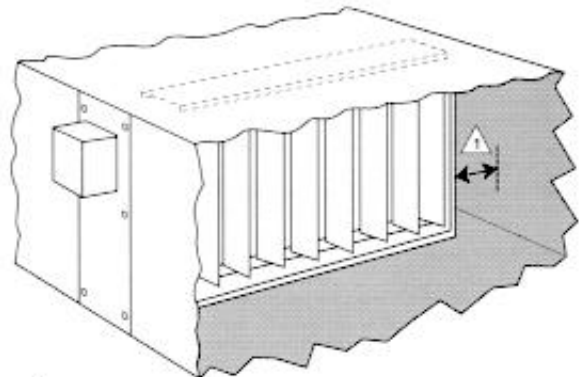

1 DAMPER IS SLIGHTLY SMALLER THAN THE AIR DUCT SIZE. THIS GAP ALLOWS A CONSTANT FLOW OF CONDITIONED AIR INTO A ZONE WHEN DAMPER BLADES ARE CLOSED.

M 513

Installation

WHEN INSTALLING THIS PRODUCT...

1. Read these instructions carefully. Failure to follow them could damage the product or cause a hazardous condition.
2. Check the ratings given in these instructions and on the product to ensure the product is suitable for your application.
3. Ensure installer is a trained, experienced service technician.
4. After completing installation, use these instructions to check product operation.



CAUTION

1. Locate and install dampers in an easily accessible location for Service and Checkout.
2. When installing Opposed Blade Zoning Dampers in vertical air ducts, always secure the front and rear of the damper to the air duct. Refer to Fig. 2.
3. Never force dampers into undersized air ducts. Excess pressure will jam damper blades.
4. Ensure high limit setting is 200° F [93° C] or lower. Higher settings can damage electric actuator.

Fig. 2—Securing back of damper to air duct.

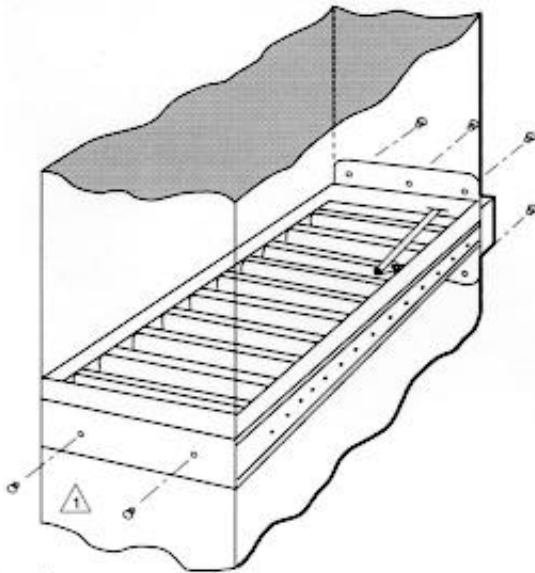

⚠ SECURE BACK OF DAMPER TO AIR DUCT USING TWO 1/4 INCH [6mm] SHEET METAL SCREWS.

M514

IMPORTANT: When installing dampers in horizontal air ducts, always mount the electric actuator and drive linkage toward the top of the air duct. Refer to Fig. 3.

Installing 2RS267 Opposed Blade Dampers

Refer to Fig. 4.

1. Ensure the 2RS267 is correctly sized to the air duct.
2. Select an 2RS267 location near the furnace plenum.
3. Cut a 3 inch [76 millimeter] opening in one side of the air duct at the location selected. Ensure the opening is cut fully to the top and bottom air duct seams.
4. Slide the 2RS267 into the air duct. Ensure the electric actuator is mounted toward the top of the air duct.

Fig. 3—Proper damper mounting position.

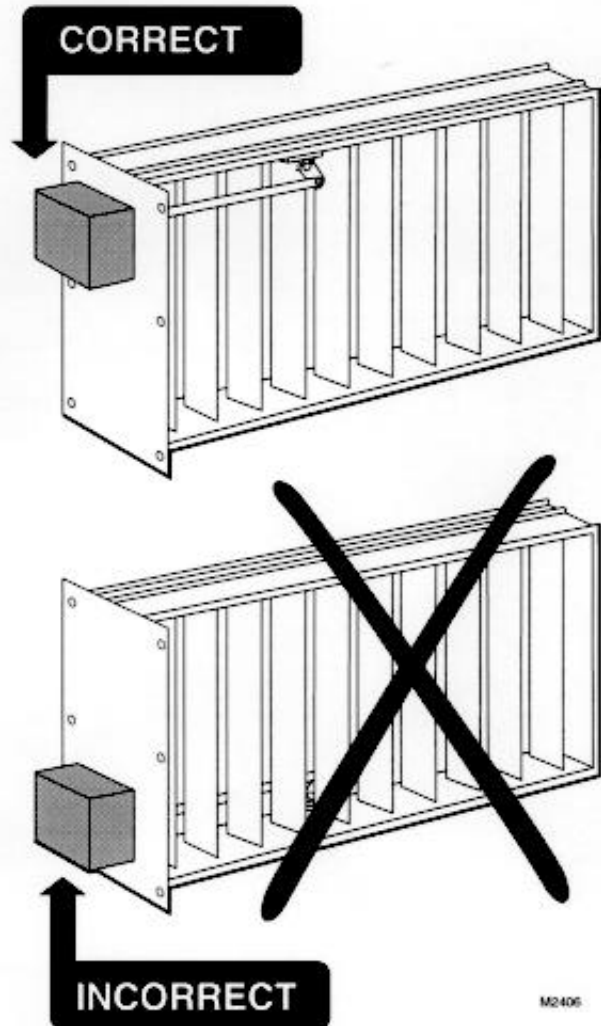

5. For small air duct sizes (less than 200 sq. in.), secure the 2RS267 mounting plate to the air duct with sheet metal screws provided.

6. For large air duct sizes (200 sq. in. or larger), secure the mounting plate to the air duct with sheet metal screws provided. Then, secure the back of the 2RS267 to the air duct. If back of 2RS267 can not be reached, install two mounting tracks. Refer to Fig. 5.

Installing Multiple Dampers and Damper Mounting Tracks

For air duct sizes longer than 30 inches, use multiple dampers and install mounting tracks inside the air ducts. Refer to Fig. 5.

Fig. 4—Installing 2RS267 Opposed Blade Dampers.

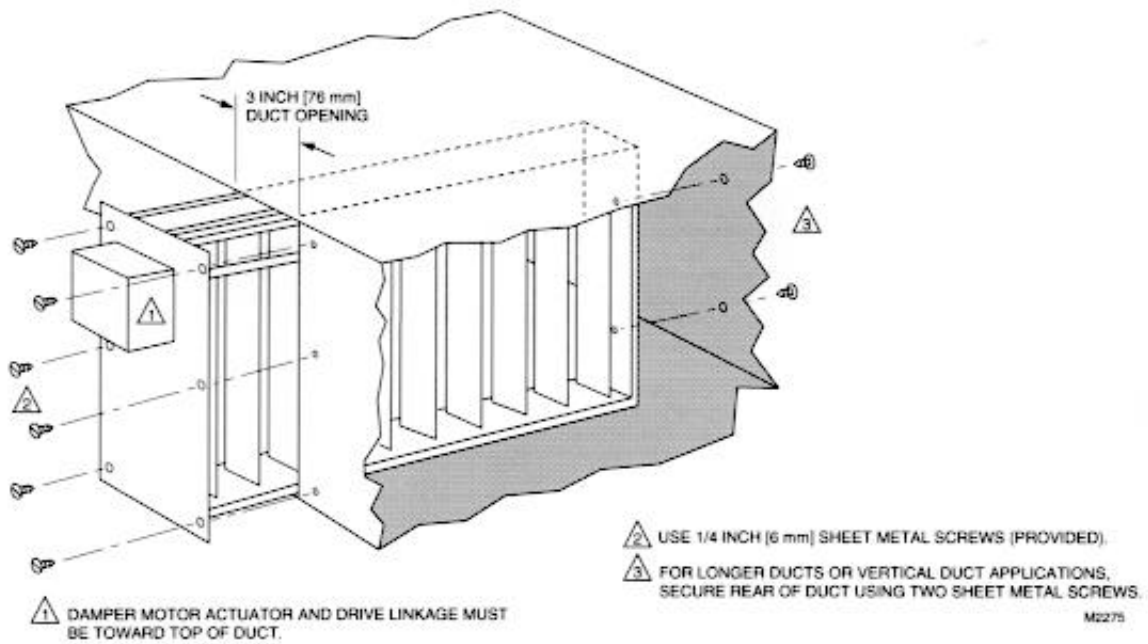
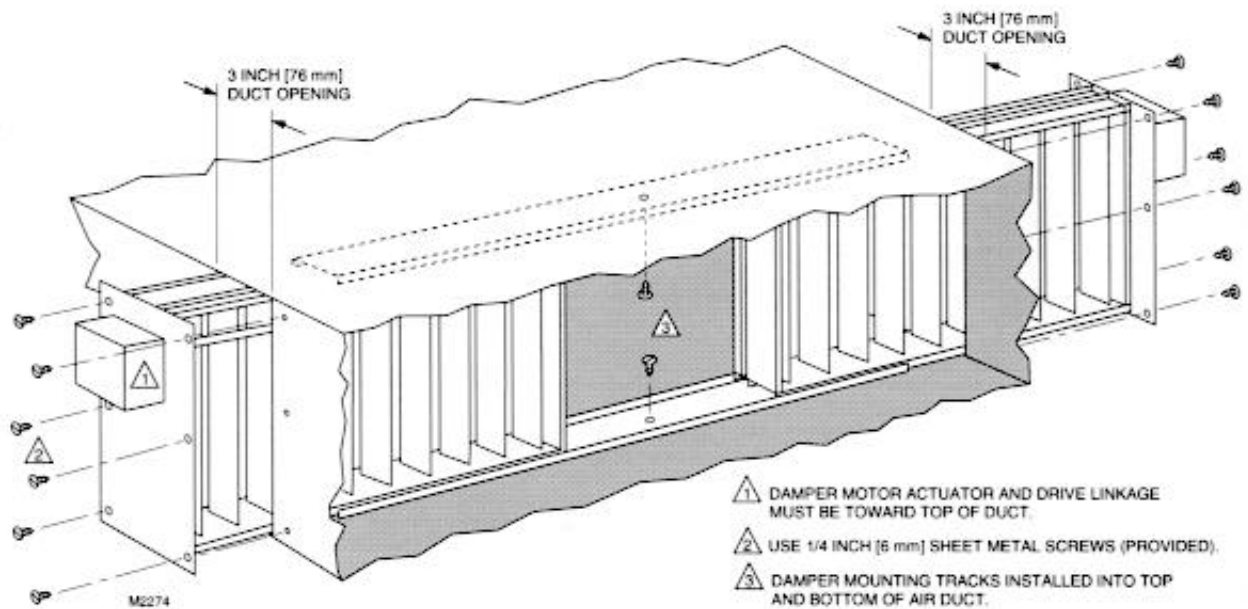

Fig. 5—Installing Multiple Dampers and Damper Mounting Tracks.



Installing 2RB267 Opposed Blade Dampers— Bottom Mount

Refer to Fig. 6

IMPORTANT: Secure the 2RB267 by inserting screws in the top and bottom of the damper, not the sides of the damper.

1. Ensure the 2RB267 is correctly sized to the air duct.
2. Select an 2RB267 location near the furnace plenum.
3. Cut a 3 inch [76 millimeter] opening in the bottom or top of the air duct at the location selected. Ensure the opening is cut fully to the air duct seams on each side.
4. Slide the 2RB267 into the air duct.
5. Secure the 2RB267 mounting plate to the air duct using sheet metal screws provided.

Fig. 6—Installing 2RB267 Opposed Blade Dampers—Bottom Mount

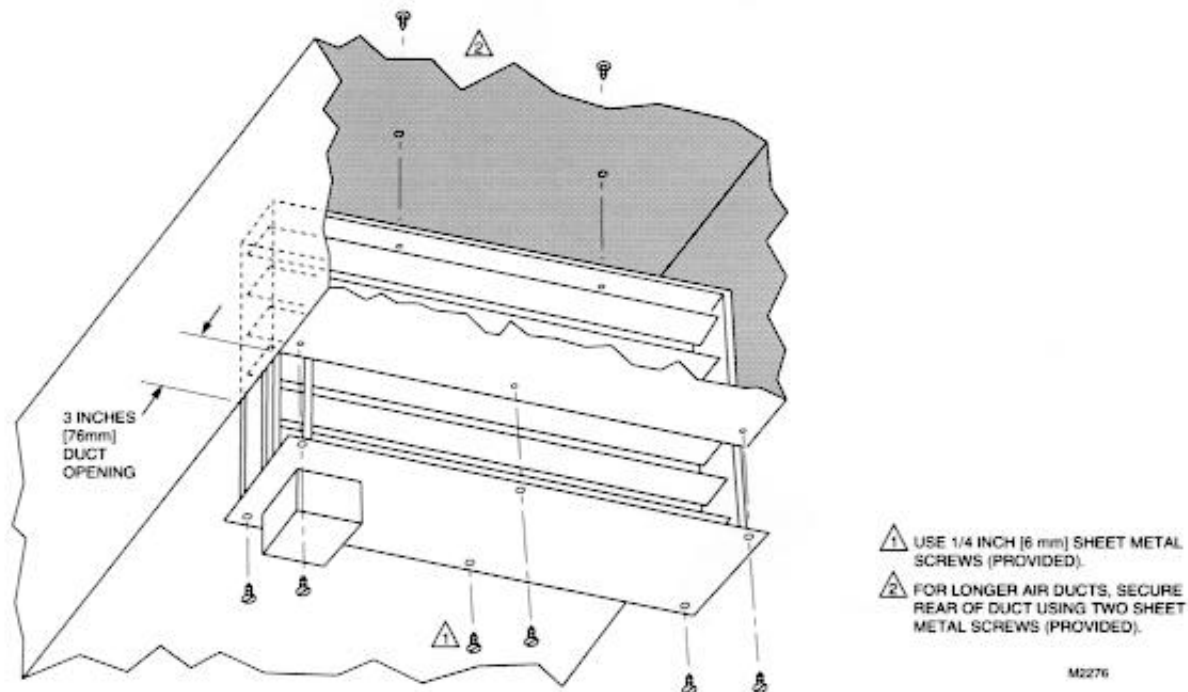
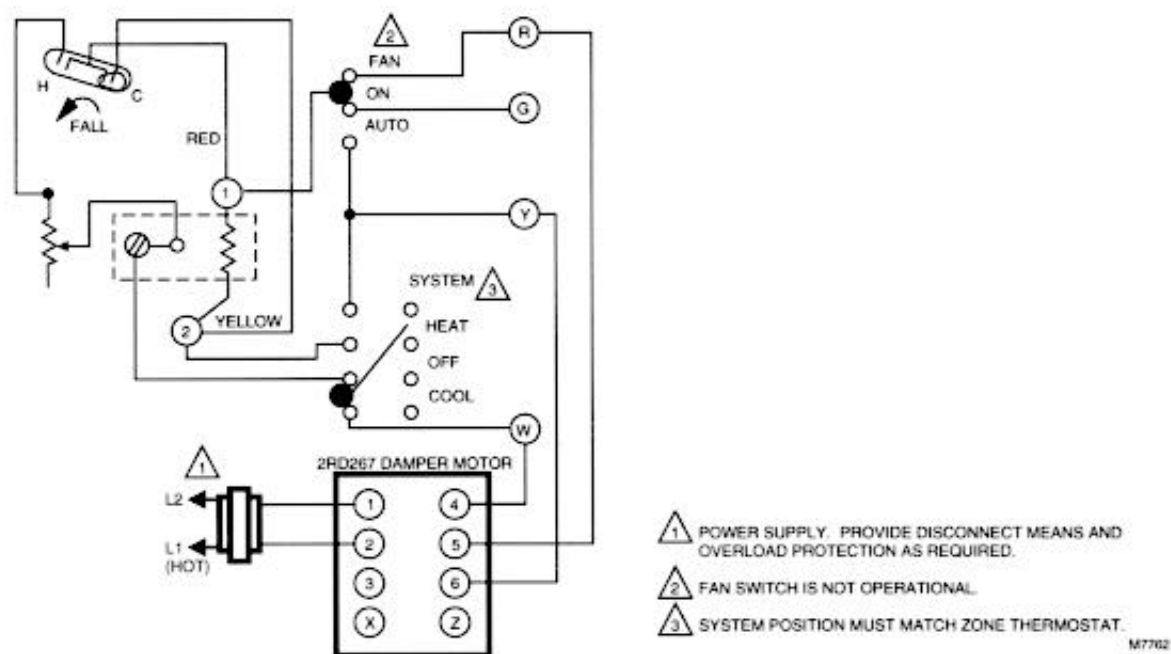

Fig. 7—Wiring Diagram for Independent Zone Applications (2TH07700124 Shown).



Wiring Independent Zone Applications

Refer to Fig. 7.

For Independent Zone Applications, follow the thermostat wiring instructions, if available. Otherwise, refer to Fig. 7 for a typical wiring diagram.

Wiring Zone Systems

For Zone Systems, follow the thermostat and central logic panel wiring instructions, if available.

Wiring Tandem Dampers

Refer to Figs. 10, 11, and 12.

When two dampers are controlled by the same thermostat (or older panel with 5-wire control circuit), such as occurs when two registers, diffusers, or dampers supply the same room or zone, the second unit is controlled by the switch action of the first unit (see Fig. 8).

Fig. 8—Tandem Wiring of Dampers to the Thermostat in an Independent Zone Application.

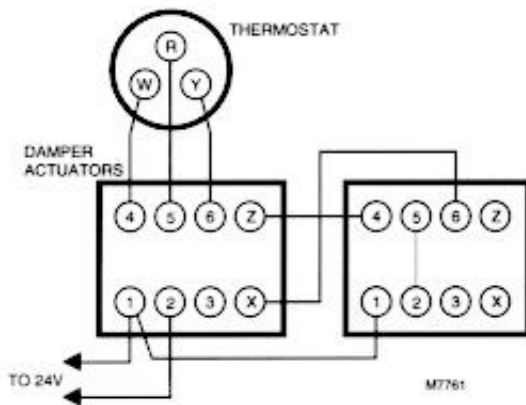

Another typical tandem wiring diagram is shown in Fig. 9. Tandem wiring of a 2RS267 Opposed Blade Damper and a 2RD267 Round Damper is shown in Fig. 10.

Fig. 9—Typical Tandem Wiring Diagram with Master Panel.

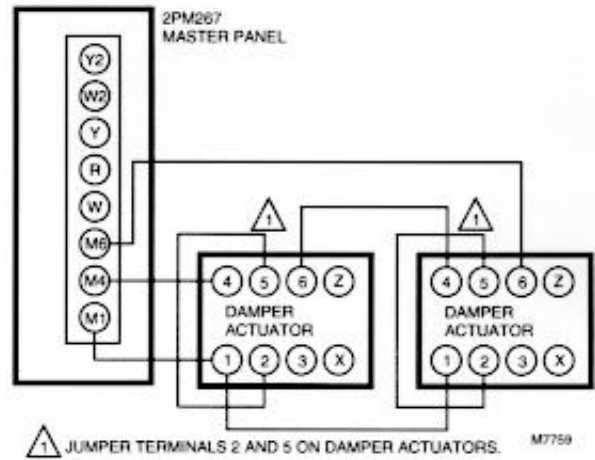
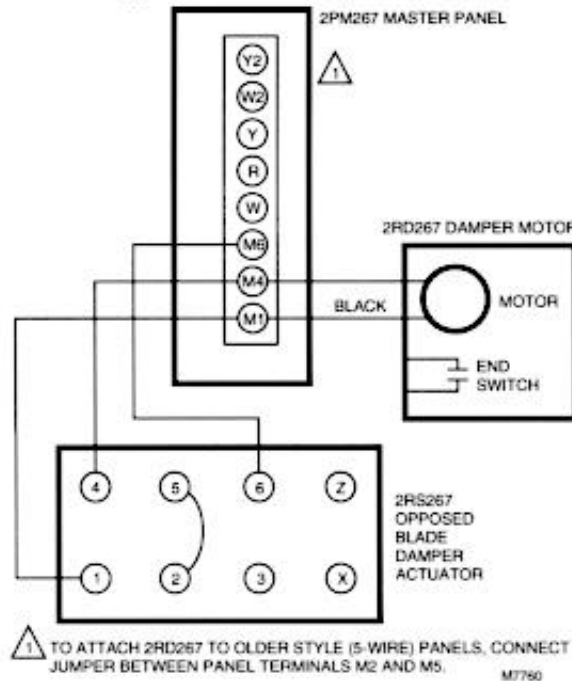

Fig. 10—Tandem Wiring of 2RS267 Opposed Blade Damper and 2RD267 Round Damper.



Checkout

After installing and wiring the dampers, turn power supply on and check out the system as follows. For complete checkout of the forced air system, refer to the system specifications.



CAUTION

Do not check damper operation by shorting across the terminals of the system controls. This bimetal or thermometer.

IMPORTANT: To ensure accurate temperature control, do not touch or breathe on the thermostat bimetal or thermometer.

DETERMINING DAMPER POSITION

To determine if a damper is open or closed, refer to Fig. 11.

Fig. 11—Determining Damper Position.

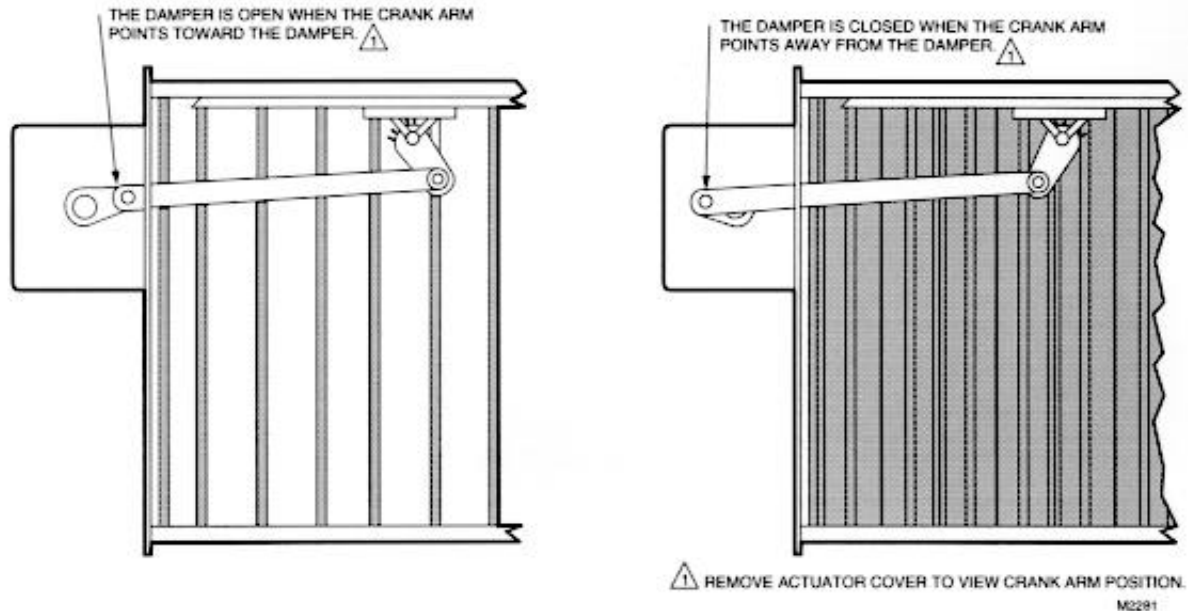

Service

Occasionally, damper blades stick while opening or closing. The problem may be caused by a worn motor switch or binding damper blades. To locate the problem, follow these steps:

CHECKING THE DAMPER BLADES

1. Remove the electric actuator enclosure (if necessary).
2. Separate the crank arm from the motor shaft using a 6-32 Allen wrench.
3. Using your hand, open and close the damper blades a number of times by pushing and pulling the crank shaft.
 - If linkage and damper blades move freely, they are working properly.
 - If linkage and damper blades require effort to open or close, replace damper and repeat step 2.

4. If the damper blades still require considerable effort to open or close, check that the damper is sized properly and that there is no pressure on the damper blades. If the damper is not sized properly, replace the old damper with a properly sized damper.

5. Attach the crank arm to the motor drive shaft.
6. If the damper blades continue to stick while opening or closing, refer to Installation instructions, page 2, to ensure the mounting screws are installed properly.
7. Ensure the damper blades close fully by shorting terminals 5 and 6. If there is a gap between damper blades:
 - a. Loosen crank arm from motor drive shaft using a 6-32 Allen wrench.
 - b. Manually, close the gap between the damper blades.
 - c. Tighten crank arm to motor drive shaft using a 6-32 Allen wrench.

CHECKING THE ELECTRIC ACTUATOR

Refer to Fig. 12

1. Connect 24V to the electric actuator terminals 1 and 2.

2. Ensure the electric actuator operates properly by shorting terminals 4 and 5 to open the damper blades and by shorting terminals 5 and 6 to close the damper blades.

- If the dampers open and close as indicated, the system is operational.
- If the dampers do not operate as indicated, replace the electric actuator and repeat steps 1 and 2.

3. Ensure the end-switch operates properly.

a. Connect a 24 V test light between terminals 1 and 3.

b. Short terminals 4 and 5. When the damper blades are fully open, the end switch should engage, the 24V test light should turn on, and the electric actuator should turn off.

c. Short terminals 5 and 6. When the damper blades are fully closed, the end switch should engage, the 24V test light should turn on, and the electric actuator should turn off.

4. If the motor and end switches do not operate as indicated, replace the electric actuator and repeat steps 1 through 4.

5. Replace the electric actuator enclosure.

REPLACING THE ELECTRIC ACTUATOR

1. Using a 6-32 Allen wrench, loosen the crank arm set screw that connects the crank arm to the motor drive shaft.

2. Remove the crank arm from the motor drive shaft.

3. Remove the two screws from the crank arm side of the actuator box.

4. Remove the electric actuator from the actuator box.

5. Install new electric actuator into actuator box.

6. Tighten two screws into crank arm side of the actuator box.

7. Attach the crank arm to the motor drive shaft.

8. Tighten crank arm set screw.

NOTE: Electric actuator is shipped in the open damper position.

Fig. 12—Checking the electric actuator.

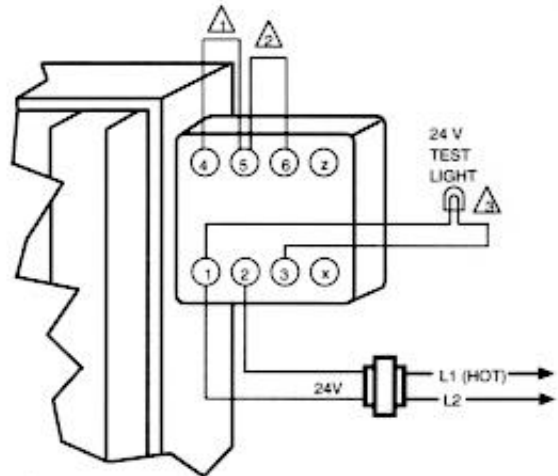

△ SHORT TERMINALS 4 AND 5 TO OPEN DAMPER BLADES.

△ SHORT TERMINALS 5 AND 6 TO CLOSE DAMPER BLADES.

△ 24 V TEST LIGHT TURNS ON WHEN DAMPER BLADES OPEN AND TURNS OFF WHEN DAMPER BLADES CLOSE.

M2278



Heating and Air Conditioning



Unitary Products Group
P.O. Box 1592, York, Pennsylvania USA 17405-1592
Subject to change without notice. Printed in U.S.A.
Copyright © by York International Corporation 1995. All rights reserved.

SHU 5M 1295 .44

Code: SBY

690.92-N3Y