

Centennial Oil Furnaces

PMP210 Multi-position (High-Boy / Horizontal)

KEEP THESE INSTRUCTIONS WITH FURNACE FOR FUTURE REFERENCE.



Furnace Manual

Contents	Page
Read this first!.....	2
1. Prepare furnace location.....	3
2. Prepare furnace and place in position	6
3. Connect supply and return ducts	8
4. Venting.....	11
5. Connect fuel oil piping	12
6. Wire furnace and burner	14
7. Start-up	17
8. Checkout procedure	17
9. Troubleshooting	19
10. Service and maintenance	20
11. Components and replacement parts.....	25
12. Dimensions and ratings	28
13. Owner's information.....	30

Hazard definitions

▲ DANGER Hazards that will cause severe personal injury, death or substantial property damage.

▲ WARNING Hazards that can cause severe personal injury, death or substantial property damage.

▲ CAUTION Hazards that will or can cause minor personal injury or property damage.

NOTICE Special instructions on installation, operation or maintenance that are important but not related to personal injury or property damage.

▲ WARNING **INSTALLER** – Read all instructions before installing. **Read page 2 first.** Follow all instructions in proper order to prevent personal injury or death.

- Consider ducting, fuel supply, venting and installation when determining furnace location.
- Any claims for damage or shortage in shipment must be filed immediately against the transportation company by the consignee.

▲ WARNING **USER** – Please read the following. Failure to comply could result in severe personal injury, death or substantial property damage.

- **This manual is for use only by your qualified heating installer / service technician.**
- Have the furnace serviced by a qualified service technician, at least annually.

▲ WARNING Do not store or use gasoline or other flammable liquids or vapors near this furnace or any other appliance.

▲ CAUTION Ventilate house while operating furnace for the first time. Odors may be emitted for a brief period.

▲ WARNING Do not alter this furnace in any way. The manufacturer will not be liable for any damage resulting from changes made in the field to the furnace or its components or from improper installation. Failure to comply could result in severe personal injury, death or substantial property damage.

▲ WARNING This manual must only be used by a **qualified heating installer / service technician.** Furnace and burner must be installed and serviced only by a qualified heating installer / service technician. Failure to comply could result in severe personal injury, death or substantial property damage.

NOTICE When calling or writing about the furnace – Please indicate furnace model number and serial number from the rating label. You may list the serial number and model number in the space provided on the “Installation and service certificate” found on page 18.

READ THIS FIRST!

WARNING Failure to adhere to the guidelines below can result in severe personal injury, death or substantial property damage.

Service and maintenance –

1. To avoid electric shock, disconnect electrical supply before performing maintenance.
2. To avoid severe burns, allow furnace to cool before performing maintenance.
3. Perform service and maintenance as described in this manual and the burner manual.
4. Do not attempt to make adjustments to the blower or motor while the furnace is in operation. Disconnect power to the furnace and be sure all parts have stopped moving before attempting adjustments or maintenance.
5. The burner must be set up and adjusted using combustion test instruments. Visual examination of the flame alone cannot determine combustion performance.

Operation -

6. Do not use the furnace as a construction heater.
7. Do not operate any furnace if the heat exchanger is damaged, corroded or pitted. Toxic flue products could enter the air stream.
8. Do not jumper, attempt to by-pass or override any limit control.
9. Do not block flow of combustion or ventilation air to furnace. Do not block or obstruct the air openings in the furnace casing.
10. Do not store or use combustible materials, gasoline, or other flammable liquids or vapors in the furnace area.
11. Do not operate the furnace if the furnace area will be exposed to air contaminants as described on page 5.
12. Should overheating occur, do not turn off or disconnect electrical supply to furnace. Instead, shut off the oil supply at a location external to the appliance, if possible.
13. Do not use this furnace if any part has been under water. Call a qualified service technician immediately, to inspect the furnace and to replace any part of the furnace, control system or burner that was submerged in water.
14. Do not operate furnace if temperature rise through heat exchanger exceeds 85°F.

15. Inspect, clean and replace (if necessary) return air filter regularly.
16. Do not obstruct return air grills or supply air outlets.
17. Supply only #2 fuel oil to the burner. Never attempt to use gasoline, a mixture of gasoline and oil, waste fuel, refuse or any other substance in the burner of furnace.

Installation -

18. Do not block flow of combustion or ventilation air to furnace. Do not block or obstruct the air openings in the furnace casing.
19. Connect furnace only to a functional vent system in good condition. Place the furnace to allow proper venting, with the shortest possible venting and minimum number of elbows.
20. Always connect and seal a return air duct to the furnace unless the furnace is located in a large space, such as an unpartitioned basement. Route the return air duct to an adjacent room if no return air manifold is used.
21. Install furnace maintaining minimum clearances for service and separation from combustible surfaces described in this manual.
22. Install, start-up, service and maintain burner per instructions in this manual and the burner manual.
23. Verify burner is properly inserted through the combustion chamber opening.
24. Furnace must be installed so that burner and control system components are protected from dripping, spraying water or rain during operation or service.
25. If installing an air conditioning evaporator coil, install the coil downstream of, or in parallel with, the furnace to prevent condensation on the furnace heat exchanger. If the coil is in parallel, provide means to prevent flow of chilled air into the furnace, including an interlock to prevent simultaneous operation of heating and air conditioning.

NOTICE Apply the following suggestions to prevent unsatisfactory operation of the furnace.

Installation –

1. Be sure to level the furnace, using a spirit level at the front and one side. If the furnace is not level, oil can drip into the combustion chamber after burner cycling and contaminate the heat exchanger and the burner head.
2. Make sure all legs are in contact with the floor to distribute the load and prevent the possibility of undue noise or vibration.
3. Avoid locating return grills in rooms that may contain undesirable odors.
4. Never locate a return air grill closer than approximately 20 feet from the furnace.
5. Locate the furnace near the center of the supply and return duct systems.
6. Always check the size of the ducts on a replacement installation, particularly if adding air conditioning.

1 Prepare furnace location

Pre-installation checklist

Verify code compliance

- Local, state, provincial, and national codes, laws, regulations and ordinances
- NFPA-31, Installation of Oil-Burning Equipment
- National Electrical Code
- All local codes and/or regulations take precedence over the instructions in this manual and should be followed accordingly.

NOTICE

PMP furnaces, their burners and controls met safe lighting and other performance criteria when furnace underwent tests specified in Underwriters Laboratories Standard UL727.

Check location and furnace specifications

- Furnace heating capacity
 - Space is large enough to provide required clearances
- Verify the installation will meet the requirements of this manual:
- Clearances (page 3)
 - Combustion/ventilation air openings (page 4)
 - Supply air duct (page 8)
 - Return air duct (page 8)
 - Vent system (page 11)
 - Fuel oil piping (page 12 plus burner manual)
 - Electrical connection (page 14)

Clearances

Minimum clearance to combustible materials

1. Install the furnace, ductwork and vent such that no combustible surface is closer than listed in Table 1.

NOTICE

Flue pipe clearances must take precedence over jacket clearances (listed below).

Service accessibility clearances

1. Provide no less than the minimum clearances given in Table 1 to ensure the furnace can be properly operated, serviced and maintained.
2. Always apply whichever clearance is **LARGER** – combustible construction or service accessibility.

Flooring and foundation

Flooring

If a combustible floor is used follow these instructions:

Upflow installation on combustible floor

PMP furnaces are approved for installation on combustible flooring, but must never be installed on carpeting.

Horizontal installation on combustible floor

Always keep the minimum installation clearances of 2 inches between the combustible floor and the furnace sides.

WARNING

Do not install furnace on carpeting even if foundation is used. Fire can result, causing severe personal injury, death or substantial property damage.

Foundation

1. Provide a solid brick or minimum 2-inch thick concrete foundation pad if any of the following is true:
 - The floor can become flooded.
 - The furnace mounting area is not level.

Residential garage installations

Take the following special precautions when installing the furnace in a residential garage. If the furnace is located in a residential garage:

- Mount the furnace a minimum of 18 inches above the floor of the garage.
- Locate or protect the furnace so it cannot be damaged by a moving vehicle.

Table 1 Minimum clearances

Minimum clearances – combustion materials (inch)			
Location	Application	Upflow	Horizontal
Sides	Furnace	2"	2"
	Supply plenum within 6 ft of furnace	1"	1"
Back	Furnace	2"	2"
Top	Furnace or plenum	1"	2"
	Horizontal warm air duct within 6' of furnace	1"	3"
Bottom	Furnace (combustible floor)	0"	0"
Flue pipe	Horizontally or below flue pipe	18"	18"
	Vertically above flue pipe	18"	18"
Front	Furnace	24"	24"

1 Prepare furnace location (continued)

Air for combustion and ventilation

▲WARNING Adequate combustion and ventilation air ensures proper combustion and reduces risk of severe personal injury or death from possible flue gas leakage and carbon monoxide emissions.

▲WARNING Do not install exhaust fan in furnace room.

Consider building construction

Older buildings with single-pane windows, minimal weather-stripping and no vapor barrier often provide enough natural infiltration and ventilation without dedicated openings.

New construction or remodeled buildings are most often built tighter. Windows and doors are weather-stripped, vapor barriers are used and openings in walls are caulked. As a result, such tight construction is unlikely to allow proper natural air infiltration and ventilation.

For buildings with tight construction, provide openings directly to outside or to a ventilated crawl space or attic. Size the openings to the same specifications as for the furnace location per the following paragraphs.

Follow state, provincial or local codes when sizing adequate combustion and ventilation air openings. In absence of codes, use the following guidelines when furnace is in a confined room (defined by NFPA 31 as less than 7,200 cubic feet per 1 GPH input of all appliances in area. A room 8 ft. high x 30.0 ft. x 30.0 ft. is 7,200 cu. ft.).

Provide two permanent openings

Openings locations

One within 12 inches of ceiling, one within 12 inches of floor. Minimum height or length dimension of each rectangular opening should be at least 3 inches.

When inside air is used

Each opening must freely connect with areas having adequate infiltration from outside. Each opening should be at least 140 sq. in. per 1 GPH input (1 sq. in. per 1,000 BTU input) of all fuel-burning appliances plus requirements for any equipment that can pull air from room (including clothes dryer and fireplace).

When outside air is used

Connect each opening directly, by ducts to the outdoors, or to crawl or attic space that freely connects with outdoors. Size per below:

- Through outside wall or vertical ducts – at least 35 sq. in. per 1 GPH input (1 sq. in. per 4,000 BTU input) of all fuel burning appliances plus requirements for any equipment that can pull air from room (including clothes dryer and fireplace).
 - Through horizontal ducts – at least 70 sq. in. per 1 GPH furnace input (1 sq. in. per 2,000 BTU input) of all fuel-burning appliances plus requirements for any equipment that can pull air from room (including clothes dryer and fireplace).
 - Where ducts are used, they should have the same cross-sectional area as free area of openings to which they connect. Compensate for louver, grille or screen blockage when calculating free air openings. Refer to the manufacturers' instructions for details. If unknown, use:
 - Wood louvers, which provide 20-25% free air.
 - Metal louvers or grilles, which provide 60-75% free air.
- Lock louvers in open position or interlock with equipment to prove open before furnace operation.

Basement installations

When the furnace is located in an unconfined space, such as an unpartitioned basement, adequate air should normally be available without additional openings. An unconfined space is defined as one having no less than 50 cubic feet room volume per 1,000 BTU/h input of all appliances in the space.

If the house is of tight construction, provide air openings to the basement directly from outside or from a ventilated attic. Size the openings as described above under "When outside air is used".

Closet installations – special NOTICE

Openings in closet doors

Provide TWO openings – one within 6 inches of top of closet door, the other within 6 inches of the bottom of closet door.

EACH opening must be at least 24 inches wide by 12 inches high.

▲WARNING Advise homeowner that the openings to the closet must never be obstructed or blocked in any way. Failure to provide adequate air for combustion and ventilation could result in severe personal injury, death or substantial property damage.

1 Prepare furnace location (continued)

Air contamination

Please review the following information on potential combustion air contamination problems.

See Table 2 for products and areas that may cause contaminated combustion air.



To prevent the potential of severe personal injury or death, check for products and/or areas listed below before installing the furnace. If any of these contaminants are found:

- Remove contaminants permanently.
- OR-**
- Isolate furnace and provide outside combustion air. See national, provincial or local codes for further information.

Table 2 Corrosive contaminants and likely locations

Products to avoid
Spray cans containing chloro/fluorocarbons
Permanent wave solutions
Chlorinated waxes/cleaners
Chlorine-based swimming pool chemicals
Calcium chloride used for thawing
Sodium chloride used for water softening
Refrigerant leaks
Paint varnish removers
Hydrochloric acid/muriatic acid
Cements and glues
Antistatic fabric softeners used in clothes dryers
Chlorine-type bleaches, detergents, and cleaning solvents found in household laundry rooms
Adhesives used to fasten building products and other similar products
Areas likely to have contaminants
Dry cleaning/laundry areas and establishments
Swimming pools
Metal fabrication plants
Beauty shops
Refrigeration repair shops
Photo processing plants
Auto body shops
Plastic manufacturing plants
Furniture refinishing areas and establishments
New building construction
Remodeling areas
Garages with workshops

2 Prepare furnace and place in position

Inspect & prepare furnace

Remove furnace from carton

Remove the furnace from its shipping carton and inspect thoroughly. Remove access panels to inspect the furnace interior.

NOTICE

Immediately file a claim with the transportation company if you discover concealed damage.

WARNING

Do not install or attempt to operate the furnace if the heat exchanger, burner or controls have been damaged. Immediately contact your furnace supplier. Operating a damaged furnace could result in severe personal injury, death or substantial property damage.

Prepare burner

Remove the burner from its shipping carton and inspect thoroughly. Read the burner manual and follow instructions for preparing and installing the burner.

Install the correct nozzle for the required firing rate, using the burner manual and the information on Section 12, p. 28 and 29 of this manual. Follow the burner manual instructions for nozzle installation. Verify the correct settings of electrodes after nozzle and burner oil tube assembly are in place.

Openings in walls, floor & ceiling

General

Ensure that the finished door opening to the furnace room is large enough to install and remove the furnace, water heater or any other appliances in the room.

Before placing furnace in a closet or small room, cut all openings required in floor, ceiling or walls for ducts and vent. This will simplify the work and prevent construction dust from entering the furnace heat exchanger.

WARNING

Verify that all clearances to combustible construction and for service accessibility will be met. The vent must be no closer than 18 inches to any combustible surface unless a type "L" double-wall vent pipe is used or the vent is constructed per the requirements of the NFPA 31. Provide a ventilated thimble per all applicable codes where vent pipe passes through a wall or ceiling. Failure to comply could result in severe personal injury, death or substantial property damage.

Duct locations and sizing

Verify that the size of the supply and return duct system is sufficient for the application. The pressure drop through the duct system must not exceed 0.2" water column.

Openings in walls, floor... (continued)

The total drop through the duct system and air conditioning condensing coil (if used) must not exceed 0.5" water column.

See suggested duct sizing in this manual. For more detailed sizing information, refer to ACCA Manual D.

Return air duct

You must install a return air duct, sealed to the furnace, even if no return manifold is used. The only exception is when the furnace is located in a large unpartitioned room, such as a basement. (A room whose volume is at least 50 cubic feet per 1,000 BTU/h input of all appliances in the room is considered large). For large rooms, return air may be taken directly at the furnace, without a return air duct. No return air register should be within 20 feet of the furnace.

Cut the required opening for the return air duct in the wall (or floor or ceiling) of the room before placing the furnace.

Install filter

Install return air filter of the size listed on Section 12, p. 28.

The filter rack is provided with the unit. You will need to attach the filter rack to the furnace for all Model PMP.

NOTICE

Verify that the filter will be easily accessible for removal after the furnace is in place.

When installing on **combustible flooring**, provide supply plenum size and floor opening as given in Table 3.

Install furnace and burner

Place furnace

Place the furnace in the desired location. Measure clearances and verify per page 3 of this manual.

Use a spirit level on the front and one side of the furnace. Make sure each of the legs is firmly in contact with the floor.

Inspect combustion chamber

Inspect the combustion chamber. Verify it is in good condition and correctly in position inside the heat exchanger. The burner opening in the chamber must align with the burner heat exchanger opening.

WARNING

The combustion chamber is constructed of ceramic fiber materials. See the WARNING information on page 21 of this manual. Comply with these instructions when handling any ceramic fiber or fiberglass materials. Failure to adhere to these guidelines could result in severe personal injury or death.

Insert burner

Following the burner manual instructions, install the burner and its gasket in the burner opening.

Secure the burner in place with the four nuts and washers provided. Wire and pipe fuel to the burner as per the burner manual and this manual.

Burner orientation

For a horizontal installation, you must turn the burner 90°, to the normal position. Always keep the motor shaft in horizontal position.

2 Prepare furnace and place in position (continued)

Blocked Vent Shut-Off (BVSO) for chimney venting (OPTIONAL)

▲WARNING It is imperative that this device be installed by a qualified agency.

This device is designed to detect the insufficient evacuation of combustion gases in the event of a vent blockage. In such a case the thermal switch will shut down the oil burner. The device will then need to be re-armed MANUALLY.

In the event that the BVSO repetitively shuts down the oil burner, a qualified technician needs to evaluate the cause of this shut down.

Refer to the figures 5 & 6 at section 6, Wiring Diagrams and detailed instructions supplied with the BVSO for the installation and wiring procedures.

It is also essential that the BVSO be maintained annually. For more details refer to the instructions supplied with the device itself, as well as the Maintenance Section.

Figure 1
Blocked Vent Shut-Off device wiring
Installation : Upflow with Vertical exhaust
(Optional)

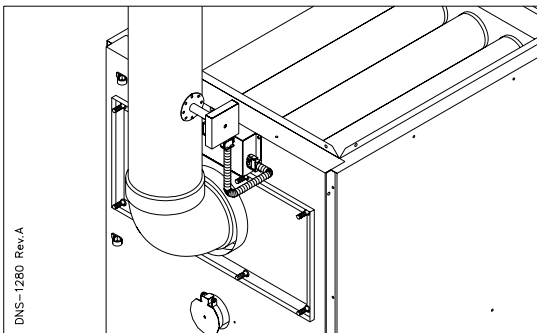

Figure 2
Blocked Vent Shut-Off device wiring
Installation : Upflow with Horizontal exhaust
(Optional)

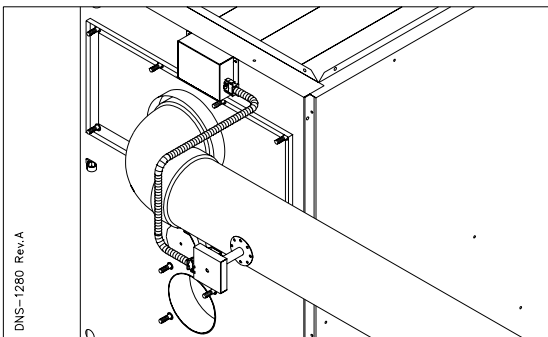

Figure 3
Blocked Vent Shut-Off device wiring
Installation : Horizontal left/right with Vertical exhaust
(Optional)

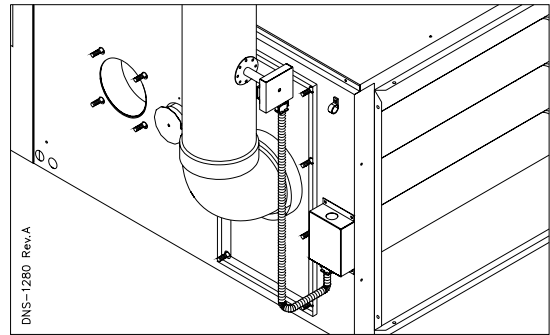
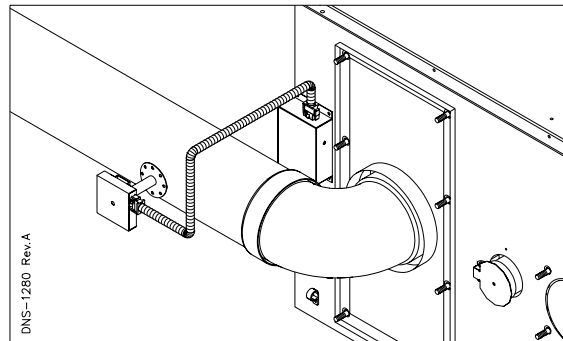

Figure 4
Blocked Vent Shut-Off device wiring
Installation : Horizontal left/right with horizontal exhaust
(Optional)



3 Connect supply and return ducts

Duct sizing

Determine airflow CFM

The temperature rise through the furnace must not exceed 85°F and should be at least 55°F for comfort. When calculating airflow, assume a temperature rise of 70°F.

The noticeable temperature change for cooling would be approximately 27-30°F. Actual temperature change will be approximately 18-21°F due to humidity of the air.

To calculate the noticeable heat temperature change (ΔT), you can use the formula:

$$\Delta T = \text{BTU/h} / (1.1 \times \text{CFM}) \quad \text{Eq. 3-1}$$

To calculate airflow when you know temperature change (ΔT), you can use:

$$\text{CFM} = \text{BTU/h} / (1.1 \times \Delta T) \quad \text{Eq. 3-2}$$

You can estimate airflow using the following rules of thumb:

- Heating: **14 CFM per 1,000 BTU/h** output Eq. 3-3
- Cooling: **400 CFM per ton** air conditioning Eq. 3-4

Determine the required airflow based on whichever is larger – heating mode or air conditioning mode.

Examples:

- What would the temperature rise be for a 100,000 BTU/h output furnace with an airflow rate of 1,200 CFM?

Use Equation 3-1 since you know CFM and BTU/h:

$$\Delta T = 100,000 / (1.1 \times 1200) = 76^\circ \text{F}$$

- The temperature rise would be 76° F.
- If the air enters the furnace at 70° F, it would leave the furnace at 70° F + 76° F = 146° F.

- What would the airflow be to obtain a 70° F rise through a 120,000 BTU/h output furnace?

Use equation 3-2 since you know ΔT and BTU/h:

$$\text{CFM} = 120,000 / (1.1 \times 70) = 1,558 \text{ CFM}$$

- The airflow would have to be 1,558 CFM to obtain a temperature rise of 70° F.

- Estimate the required airflow for a 75,000 BTU/h output furnace installed with a 2-ton air conditioning evaporator coil.

Heating mode airflow (use Equation 3-3):

$$\text{CFM} = 75 \times 14 = 1,050 \text{ CFM}$$

Cooling mode airflow (use Equation 3-4):

$$\text{CFM} = 2 \times 400 = 800 \text{ CFM}$$

- The larger number is 1,050 CFM (heating), so the duct system should be sized for 1,050 CFM.
- The supply duct would need to be 16" round or a rectangular equivalent such as 8" x 25" or 12" x 16", using Table 4, page 9.

- Estimate the required airflow for the same furnace installed with a 4-ton air conditioning evaporator coil.

Heating mode airflow is still 1,050 CFM.

Cooling mode airflow (use Equation 3-4):

$$\text{CFM} = 4 \times 400 = 1,600 \text{ CFM}$$

- The larger number is 1,600 CFM (cooling), so the duct system should be sized for 1,600 CFM.
- The supply duct would need to be 18" round or a rectangular equivalent such as 8" x 36" or 12" x 21", using Table 4, page 9.

CAUTION

Always check the size of existing ducts, particularly if you are adding air conditioning. The air pressure loss through the cooling evaporator coil reduces available airflow. If the ducts are too small as well, the system may not work satisfactorily on either heating or cooling.

Determine duct dimensions

Table 4, page 9, and Table 5, page 10, provide typical round and rectangular duct sizes for rectangular and flat oval galvanized ducts. Do not apply these tables to size ductwork if the total equivalent length of the duct exceeds approximately 100 feet. For longer systems or for duct board, fiberglass-lined or flexible duct sizing, use the ACCA Manual D or the ACCA duct sizing slide rule. These tables are based on pressure loss of approximately 0.10" water column per 100 feet equivalent length of duct.

Use Table 3 below to size or check sizing of take-offs to supply registers or return grills.

Verify the size and type of registers, diffusers and grills from the manufacturer's ratings. Do not exceed the recommended flow rate. The pressure drop allowance for each should not exceed approximately 0.05" water column.

Install a return air filter, sized per specifications in Section 12, p. 28.

Use only a return air filter mounted to the furnace. Do not add additional filters unless the duct system is carefully sized to allow for the additional pressure drop.

Table 3 Suggested maximum flow to runouts

TAKE-OFF SIZE (Inches)	CFM	
	SUPPLY	RETURN
Sheet metal or ductboard		
5 Round	60	45
6 Round	100	75
7 Round	140	110
8 Round	210	160
3 ¼ x 8 Stack	70	55
3 ¼ x 10 Stack	100	75
3 ¼ x 14 Stack	140	110
2 ¼ x 12 Stack	70	55
2 ¼ x 14 Stack	90	70
Flexible duct (keep bends to minimum)		
6 Round	55	40
8 Round	120	90
10 Round	200	160
12 Round	320	250
14 Round	480	375
16 Round	660	530
18 Round	880	680
20 Round	1200	900

3 Connect supply and return ducts (continued)

Duct sizing (continued)

Table 4 Typical duct sizing for systems not over 100 feet equivalent length – round or rectangular galvanized

Typical duct sizing																		
(For approximately 0.10 inch w.c. in a typical residential installation of galvanized metal duct)																		
CFM	Round duct diameter (inches)	Rectangular duct equivalent sizes																
		Minimum width (inches) for duct heights (inches) of :																
		4	5	6	7	8	9	10	12	14	16	18	20	22	24	26	28	30
		x	x	x	x	x	x	x	x	x	x	x	x	x	x	x	x	x
45	4	4	4	4	-	-	-	-	-	-	-	-	-	-	-	-	-	-
65	5	6	5	4	4	-	-	-	-	-	-	-	-	-	-	-	-	-
100	6	8	6	5	5	4	4	-	-	-	-	-	-	-	-	-	-	-
150	7	12	9	7	6	5	5	5	4	4	-	-	-	-	-	-	-	-
200	8	14	11	9	8	7	6	6	5	4	4	-	-	-	-	-	-	-
250	9	18	13	10	9	8	7	6	6	5	5	4	4	-	-	-	-	-
300	9	20	15	12	10	9	8	7	6	6	5	5	4	4	-	-	-	-
400	10	26	19	15	13	11	10	9	8	7	6	6	5	5	5	4	4	-
500	12	32	23	18	15	13	12	11	9	8	7	6	6	6	5	5	5	5
600	12	38	28	22	18	15	13	12	10	9	8	7	7	6	6	6	5	5
700	12	46	32	25	20	17	15	14	11	10	9	8	7	7	7	6	6	6
800	14	52	36	28	23	19	17	15	13	11	10	9	8	8	7	7	6	6
900	14	58	41	31	25	21	19	17	14	12	11	10	9	8	8	7	7	7
1000	16	64	45	34	28	23	20	18	15	13	11	10	9	9	8	8	7	7
1100	16	72	49	38	30	25	22	19	16	14	12	11	10	9	9	8	8	7
1200	16	-	54	41	33	27	24	21	17	15	13	12	11	10	9	9	8	8
1300	16	-	58	44	35	29	25	22	18	16	14	12	11	10	10	9	9	8
1400	18	-	63	47	38	31	27	24	19	16	14	13	12	11	10	10	9	9
1500	18	-	68	51	40	34	29	25	20	17	15	14	12	12	11	10	10	9
1600	18	-	72	54	43	36	30	27	21	18	16	14	13	12	11	11	10	9
1700	18	-	-	58	45	38	32	28	23	19	17	15	14	13	12	11	10	10
1800	18	-	-	61	48	40	34	29	24	20	17	16	14	13	12	11	11	10
1900	20	-	-	64	51	42	35	31	25	21	18	16	15	14	13	12	11	11
2000	20	-	-	68	53	44	37	32	26	22	19	17	15	14	13	12	12	11
2200	20	-	-	-	59	48	41	35	28	23	20	18	16	15	14	13	12	12
2400	22	-	-	-	64	52	44	38	30	25	22	19	17	16	15	14	13	12
2600	22	-	-	-	69	56	47	41	32	27	23	21	19	17	16	15	14	13
2800	22	-	-	-	-	61	51	44	34	29	25	22	20	18	17	15	15	14
3000	22	-	-	-	-	65	54	47	37	30	26	23	21	19	17	16	15	14
3500	24	-	-	-	-	-	63	54	42	34	29	26	23	21	19	18	17	16
4000	26	-	-	-	-	-	72	61	47	39	33	29	26	23	21	20	19	18



Do not apply this table for duct systems over approximately 100 equivalent feet length. For longer systems or systems using other duct materials, refer to ACCA Manual D. Incorrectly sizing duct systems can result in unsafe or uncomfortable operation.

3 Connect supply and return ducts (continued)

Duct sizing (continued)

Table 5 Typical duct sizing for systems not over 100 feet equivalent length – round or flat oval galvanized

Typical duct sizing														
(For approximately 0.10 inch w.c. in a typical residential installation of galvanized metal duct)														
CFM	Round duct diameter (inches)	Flat oval duct equivalent sizes												
		Minimum width (inches) for duct heights (inches) of :												
		3	4	5	6	7	8	9	10	12	14	16	18	20
		x	x	x	x	x	x	x	x	x	x	x	x	x
45	4	6	5	-	-	-	-	-	-	-	-	-	-	-
65	5	8	6	-	-	-	-	-	-	-	-	-	-	-
100	6	11	8	7	-	-	-	-	-	-	-	-	-	-
150	7	16	11	9	8	-	-	-	-	-	-	-	-	-
200	8	21	15	11	10	8	-	-	-	-	-	-	-	-
250	9	26	18	14	11	10	9	-	-	-	-	-	-	-
300	9	30	20	16	13	11	10	-	-	-	-	-	-	-
400	10	40	26	20	16	14	12	11	-	-	-	-	-	-
500	12	49	32	24	19	16	14	13	12	-	-	-	-	-
600	12	59	38	28	22	19	16	15	13	-	-	-	-	-
700	12	69	44	32	25	21	18	16	15	13	-	-	-	-
800	14	-	50	36	29	24	20	18	16	14	-	-	-	-
900	14	-	56	41	32	26	22	20	18	15	-	-	-	-
1000	16	-	63	45	35	29	24	22	19	17	15	-	-	-
1100	16	-	69	49	38	31	26	23	21	18	16	-	-	-
1200	16	-	75	53	41	33	28	25	22	19	17	-	-	-
1300	16	-	-	58	44	36	30	26	24	20	18	-	-	-
1400	18	-	-	62	47	38	32	28	25	21	18	17	-	-
1500	18	-	-	66	50	41	34	30	26	22	19	18	-	-
1600	18	-	-	71	54	43	36	31	28	23	20	18	-	-
1700	18	-	-	-	57	46	38	33	29	24	21	19	-	-
1800	18	-	-	-	60	48	40	35	31	25	22	20	-	-
1900	20	-	-	-	63	50	42	36	32	26	23	21	19	-
2000	20	-	-	-	67	53	44	38	33	27	24	21	20	-
2200	20	-	-	-	73	58	48	41	36	29	25	23	21	-
2400	22	-	-	-	-	63	52	44	39	32	27	24	22	21
2600	22	-	-	-	-	68	56	48	42	34	29	25	23	22
2800	22	-	-	-	-	-	60	51	44	36	30	27	24	23
3000	22	-	-	-	-	-	64	54	47	38	32	28	26	24
3500	24	-	-	-	-	-	-	63	54	43	36	32	28	26
4000	26	-	-	-	-	-	-	71	61	48	40	35	31	29

⚠WARNING

Do not apply this table for duct systems over approximately 100 equivalent feet length. For longer systems or systems using other duct materials, refer to ACCA Manual D. Incorrectly sizing duct systems can result in unsafe or uncomfortable operation.

4 Venting

General venting requirements

▲WARNING

Failure to follow all instructions can result in flue gas spillage and carbon monoxide emissions, causing severe personal injury or death.

▲DANGER

Inspect existing chimney before installing furnace. Clean chimney thoroughly. Replace or repair chimney if visual inspection indicates chimney may be unsuitable for use. Insufficient draft can cause flue gas leakage and carbon monoxide emissions. Failure to clean or replace perforated pipe or tile lining and/or patch mortar and joints can cause severe personal injury or death.

- PMP furnaces are designed to operate with an over-fire draft of $-0.01''$ to $-0.02''$ w.c. Proper draft for these oil furnaces may be achieved using either a conventional chimney (natural draft) or a power vent (sidewall) system that has been properly designed for use with oil-fired equipment. Power vent manufacturer's instructions must be followed.
- Use vent material approved by local codes for oil-fired burners. In their absence, refer to:
 - NFPA 31, Installation of Oil-Burning Equipment.
 - NFPA211, Standard for Chimneys, Fireplaces, Vents and Solid Fuel Burning Appliances.
 - In Canada, refer to CSA B139, Installation Code for Oil-Burning Equipment.
 - NFPA-211 requires chimney to be lined before connected to furnace.
- To prevent downdrafts, extend chimney at least 3 feet above highest point where it passes through roof and 2 feet higher than any portion of building within 10 feet. Increase chimney cross-sectional area and height at least 4% per 1,000 feet above sea level.
- Provide minimum clearances from vent (flue) pipe to combustible material:
 - Single-wall vent – 18 inches minimum
 - Type "L" double-wall vent – 6 inches minimum

NOTICE

Oversized chimneys, outside masonry chimneys and/or derated inputs can result in condensation in chimney.

Connect venting

▲WARNING

Long horizontal vent runs, excessive number of tees and elbows, or other obstructions restricting combustion gas flow can result in the possibility of condensation, flue gas leakage and carbon monoxide emissions, which can lead to severe personal injury or death.

1. The horizontal vent must slope upwards, away from the furnace, a minimum of $\frac{1}{4}$ inch per foot.
2. Connection must be made above bottom of chimney to avoid blockage. Vent pipe must not enter chimney far enough to cause obstruction. Use thimble or slip joint where vent pipe enters chimney to allow removal for cleaning.
3. When burner and furnace are properly installed, draft overfire will be approximately $-0.01''$ to $-0.02''$ w.c. Install barometric

Connect venting (continued)

control in vent, per control manufacturer's instructions, when excess draft needs to be relieved or to comply with applicable codes and regulations. Use draft gauge to adjust proper opening.

4. An induced draft fan for the chimney may be necessary if:
 - Excessive resistance to flow of combustion gases can be expected.
 - Cross-sectional area of chimney is smaller than minimum recommended.
 - Chimney height is less than recommended.
 - When using induced draft fan seal all vent joints and interlock burner with fan operation.

Vent dampers

▲WARNING

Do not install a thermal-type vent damper on this furnace. Failure to comply could result in severe personal injury, death or substantial property damage.

NOTICE

If a vent damper is required, use only a motorized one, installed and wired in the furnace according to the vent damper manufacturer's instructions.

Barometric draft control

Install a barometric control in the vent, per the manufacturer's instructions, when excess draft needs to be relieved or to comply with applicable codes and regulations. Use draft gauge to adjust proper opening.

1. Install a barometric draft control in the vent pipe at least one foot from the furnace vent connection, preferably in the highest part of the vent pipe before the vent enters the chimney. If headroom does not provide enough clearance to locate the control at least one foot from the vent connection, install an elbow at the furnace and mount the control in an horizontal pipe at least one foot from the elbow. Install an elbow after the control to turn vertically.
2. The barometric draft control must be located in the same room as the furnace to operate correctly.
3. Ensure that the barometric draft control is accessible. Adjust the damper to obtain the correct overfire draft, as described in this manual and the burner manual.

5 Connect fuel oil piping

General oil piping requirements

- Location and installation of oil tanks, oil piping and burners must follow:
 - NFPA 31, Standard for the Installation of Oil-Burning Equipment.
 - In Canada, CSA B139, Installation of Oil-Burning Equipment.
 - Local codes and regulations.
 - Information provided with burner and fuel pump.
- If any part of the fuel oil tank is above burner level, an anti-siphon device must be used to prevent the flow of oil in case of an oil line break.
- Support oil lines as required by codes.
- Make tank connections with swing joints or copper tubing to prevent breakage in case the tank settles. Make swing joints so they will tighten as tank settles. Non-hardening pipe joint compounds should be used on all threads.

⚠ WARNING Do not use Teflon tape as an oil pipe sealant. It can cause valves to fail, creating hazards. Use only flare fittings. Do not use compression fittings. Failure to comply could result in severe personal injury, death or substantial property damage from oil leakage and/or fire hazard.

- Underground pipe must be run in a casing to prevent oil leaking into the ground or under the floor. Check local codes for information.

Oil piping connection at burner

- Connect oil line to burner using a flare fitting.

⚠ WARNING Use of any connection other than a flare fitting at the oil connection to the burner could result in a fuel oil leak, with the potential for severe personal injury, death or substantial property damage.

- See local codes for appropriate arrangement and piping of filter, control valves, etc. connecting to oil tank.
- Refer to burner manual for oil system requirements. Verify that suction lift does not exceed stated limit. Where lift exceeds limit for a one-pipe system, use a two-pipe system as directed in burner manual.

6 Wire furnace & burner

WARNING Electric shock hazard. It can cause severe personal injury or death if the power source, including the service switch on the furnace, is not disconnected before installation or servicing.

Wire burner

The burner harness is factory-wired to the furnace. Plug the burner harness into the matching burner connector. Refer to the wiring diagram on page 14 for further information.

Install and wire thermostat

Locate the room thermostat on an interior wall in the natural circulating path of room air. Do not locate thermostat so it is exposed to cold air infiltration, drafts from windows or doors, air currents from supply or return air registers, behind obstructions, on a shelf, in a closet, or in a corner.

Ensure the thermostat won't be exposed to heat from nearby fireplace, radio, television, lamp or rays from the sun. Do not mount thermostat on a wall over a supply or return duct, chimney or vent.

Wire thermostat to furnace and set thermostat anticipator as shown on wiring diagrams on page 16.

Connect power wiring

All wiring must conform to:

- National Electrical Code, ANSI/NFPA 70, latest edition and any additional national, state or local codes.
- In Canada, CSA C22.1 Canadian Electrical Code Part One and any local codes.
- Wiring must be N.E.C. Class 1. If original wire, as supplied with furnace, must be replaced, type 105°C wire or equivalent must be used. Supply wiring to furnace must be sized for the load required (see Section 12, p. 27).
- Provide electrical ground at furnace as required by codes.

Connect 120 VAC/60 Hertz, single phase separate electrical line from the main house panel to the power leads in the furnace electrical box as shown on wiring diagram on page 14. Provide a fused disconnect in the power wiring, following all local codes.

Ensure that the wire size and type is adequate for the electrical load (see Section 12, p. 27 and furnace nameplate for value).

Fan Control

On units equipped with 4-speed blower motors, the supply air must be adjusted based on heating output and the static pressure of the duct system. For the desired air flow refer to the following table as well as the air flow tables based on static pressure in Section 12, p. 28 and 29 of this manual

Blower Speed Adjustments 4-speed motors

Furnace Application	Heating Input	Recommended Blower Speed
Heating	1.20 USGPH	MED-HIGH
	1.35 USGPH	HIGH
	1.50 USGPH	HIGH

To effect the adjustment, the RED and BLUE wires can be changed on the motor. Also, refer to the position of the wires on the electronic board of the unit and consult the wiring diagram. If the heating and the air conditioning speeds are the same, the RED wire must be moved to "UNUSED LEADS" on the electronic board and the jumper provided with the BLUE wire must be used between the "HEAT" and "COOL" terminals.

The blower start/stop delays can be adjusted by positioning the DIP switches on the electronic board as shown on the following figures.

Blower "OFF" delay Board # ST9103A

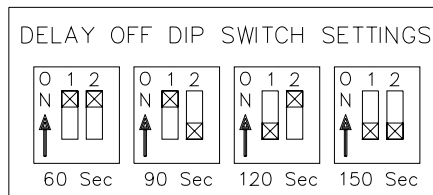

DNS-1080 Rev. A

Blower start / stop delays Board # 1158

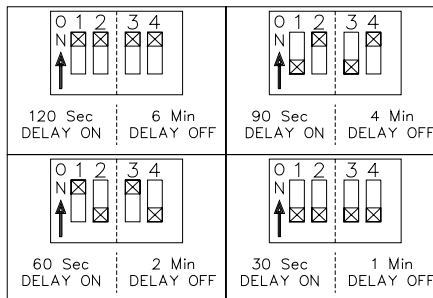

DNS-1080 Rev. A

6 Wire furnace and burner^(continued)

Figure 5
Blocked Vent Shut-Off device wiring
(Optional)

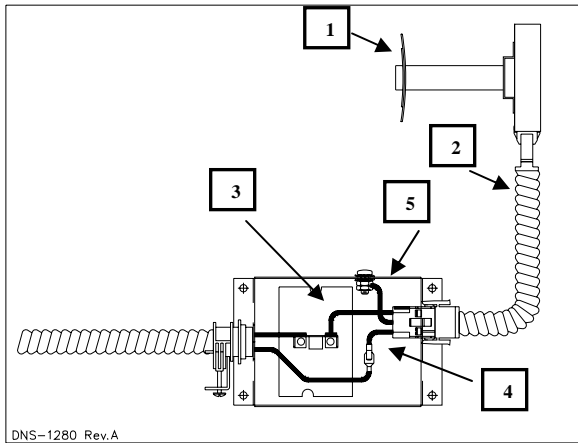

1. Blocked Vent Shut-Off device (BVSO)
2. Electrical kit supplied.
3. Connect one red wire to limit switch.
4. Disconnect red wire from limit switch and connect to one red wire from BVSO.
5. Connect the green ground wire to a cabinet screw.

6 Wire furnace & burner (continued)

Figure 6 Wiring – PMP furnace with direct-drive blowers (Beckett, Carlin and Riello burners)

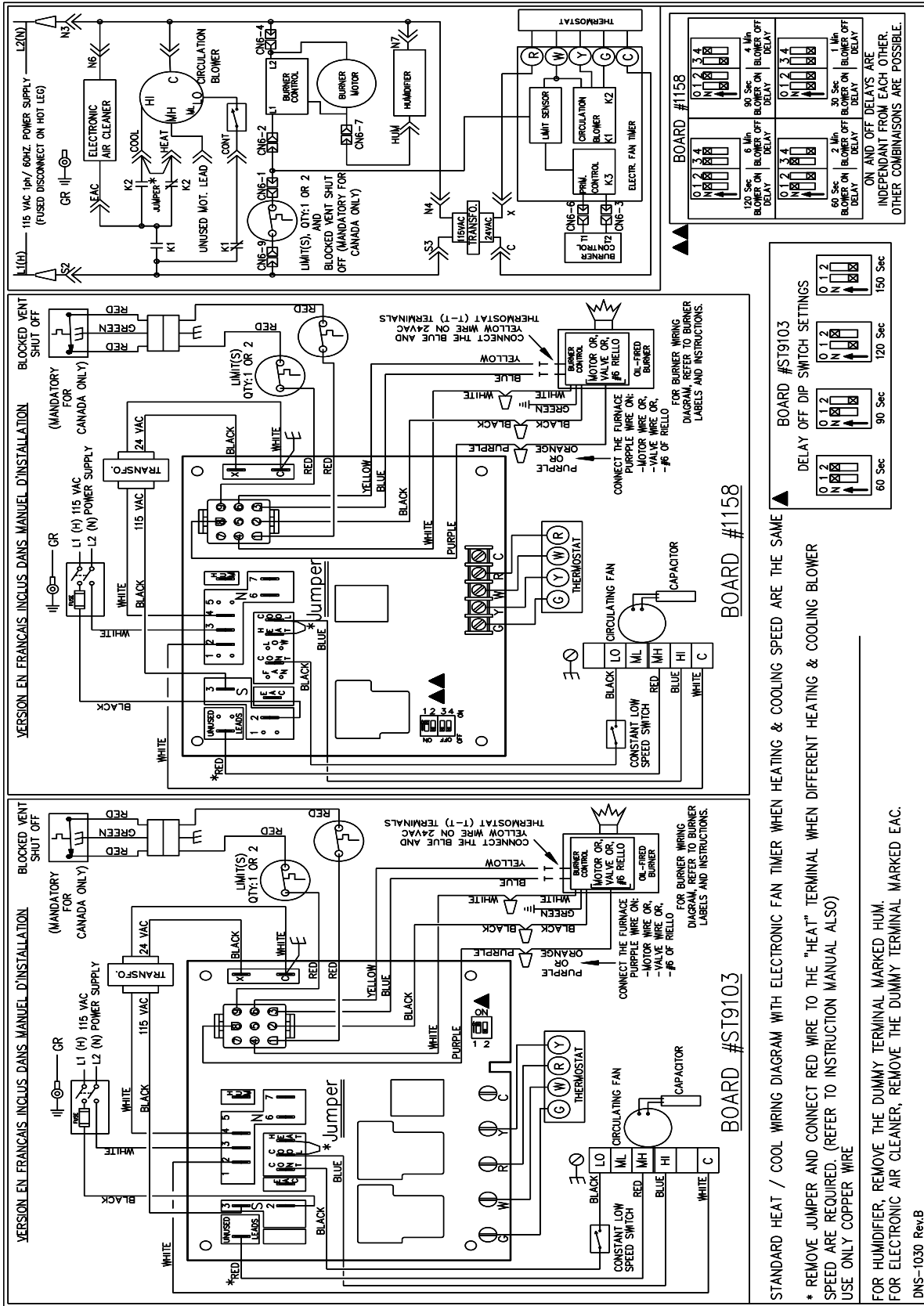

7 Start up

⚠ DANGER Follow information below to prevent severe personal injury, death or substantial property damage:

- Do not use gasoline, crankcase drainings or any oil containing gasoline. See burner manual for proper fuel oil.
- Do not attempt to start burner when excess oil has accumulated, when unit is full of vapor or when combustion chamber is very hot.
- Do not start burner unless collector box, breeching and burner mounting plate are secured in place.
- Never burn garbage or paper in the furnace.
- Never leave combustible material around it.

To start furnace

1. Factory burner adjustment and settings may not be suitable for specific job conditions. Refer to burner manual for burner start up, adjustment and checkout procedures.
2. Set room thermostat to call for heat.
3. Start burner as described in burner manual.
4. The furnace blower will delay for a short time after burner starts, until the Limit/Fan switch senses air temperature above the fan ON setting.
5. Set room thermostat to its lowest setting. Burner should turn off.
6. Furnace blower will continue to run until the Limit/Fan switch senses air temperature below the fan OFF setting.
7. Set the room thermostat to call for heat again. Allow furnace to heat to design temperature. Then adjust burner for correct combustion, using combustion test equipment. Adjust burner for:
Draft: -0.01" to -0.02" water column draft in furnace combustion chamber.
CO₂: between 10% and 11½ %, with 0 smoke.

To start furnace (continued)

⚠ WARNING Make final burner adjustments using combustion test equipment to assure proper operation.

8. Check furnace and duct system for proper operation and conditions.
9. Inspect vent system for proper operation.
10. To set Limit/Fan switch:
The blower operates until the air temperature drops below the fan OFF setting. If the air at the supply registers is too warm at blower start up or shutdown, lower the fan OFF and ON settings on the Limit/Fan switch.
To check operation of the limit switch, slide a piece of cardboard into the furnace filter slot. After a few minutes of operation (not more than 5 minutes), the burner should shut off (limit switch open). The blower will operate until the furnace cools down. Remove cardboard when finished.
11. Perform complete test of the burner cad cell control as per the burner manual instructions.

To shut down furnace

1. Set the room thermostat to its lowest setting.
2. Turn off the disconnect switch on the 120-VAC power line to the furnace.
3. If the burner will be shut down for an extended time, tightly close all oil valves.
4. Refer to burner manual for any additional instructions.

8 Checkout procedure

Furnace selection

- ..1. Heat loss BTU/h at °F outdoor design temperature.
- ..2. Furnace model..... output BTU/h.
- ..3. Burner model nozzle: gph ° type.....
- ..4. Burner pump pressure psig.

Furnace installation

- ..5. Is the furnace level and are all legs in contact with the floor?
- ..6. Are return and supply ducts securely attached to furnace?
- ..7. Are fuel filter and fuel lines installed and inspected as per the burner manual?
- ..8. Are furnace and burner wired as per the wiring diagram?
- ..9. 120 VAC wiring: type..... size AWG.

9 Troubleshooting

Before beginning these troubleshooting procedures, ALWAYS :	
<ul style="list-style-type: none"> • Check 120 volt supply to furnace. If there is no supply voltage, check fuses and service switch. CAUTION : When testing electrical equipment, always follow standard electrical safety procedures. 	<ul style="list-style-type: none"> • To successfully service the oil furnace, you must have these instruments : <ul style="list-style-type: none"> • smoke tester • carbon-dioxide (CO₂) or oxygen (O₂) analyzer • draft gauge (scale should read from -.01" w.c. to -.25" w.c.) • volt/OHM/milliamper multimeter • pressure gauge capable of reading 0-150 lb/sq. inch (for oil only) • Be familiar with these instruments as well as the burner manufacturers recommended settings.
<ul style="list-style-type: none"> • Make sure thermostat is calling for burner operation. 	
<ul style="list-style-type: none"> • Check oil supply and make sure all valves are open. 	

Symptom – Burner	Possible corrections :	
Burner motor does not start.	<ul style="list-style-type: none"> • Check fuses and make sure service switch is on. 	<ul style="list-style-type: none"> • Check for voltage from primary relay to burner motor. Make sure the primary relay has not locked out on safety.
	<ul style="list-style-type: none"> • Check for line voltage into furnace junction box. 	<ul style="list-style-type: none"> • Make sure the thermostat is calling for heat and that the wiring to the thermostat is correct and tight.
Burner short cycles or locks out on primary relay safety.	<ul style="list-style-type: none"> • If the primary relay control is not popping out the reset button, measure the milliamperage at the thermostat and set the heat-anticipator accordingly. Also check wiring from the thermostat to the burner. 	<ul style="list-style-type: none"> • Check the alignment of the cad cell to assure it is aimed at the fire.
	<ul style="list-style-type: none"> • Check nozzle and electrode position. (Reference burner manufacturers instructions). 	<ul style="list-style-type: none"> • Check ignition transformer output
Unable to achieve clean combustion by setting air adjustments.	<ul style="list-style-type: none"> • Check tube insertion and alignment. 	<ul style="list-style-type: none"> • Check nozzle and electrode position (Reference burner manufacturers instructions).
	<ul style="list-style-type: none"> • Replace nozzle. 	<ul style="list-style-type: none"> • Check pump pressure (varies with manufacturer and application; see burner manual).
	<ul style="list-style-type: none"> • Check overfire draft. 	
To check CAD cell operation, use the following procedure :	<ol style="list-style-type: none"> 1. Remove CAD cell leadwires from the f-f terminals on the primary safety control, then start burner. Shortly after burner starts, place a temporary jumper between terminals f-f. Connect ohmeter across CAD cell leadwires-resistance should be under 1,600 ohms. 	<ol style="list-style-type: none"> 3. With burner off, check dark cell resistance across CAD cell leadwires. Resistance should be greater than 20,000 ohms. If cell resistances are different from above, recheck wiring and location of cell, etc. If necessary, replace plug-in portion of cell.
	<ol style="list-style-type: none"> 2. Stop burner and remove temporary jumper. 	

Symptom – Furnace blower	Possible corrections :	
Furnace blower will not start.	<ul style="list-style-type: none"> • Check for 120V to the blower motor. If present, replace motor. 	
	<ul style="list-style-type: none"> • Check wiring from Fan and Limit control. See if blower motor will run when it is switched on manually at the thermostat sub-base (if sub-base is installed). 	
Blower short cycles on limit control.	<ul style="list-style-type: none"> • Return ducts may be undersized. 	

10 Service and maintenance

Annual service and start-up

▲WARNING Follow the “Service and maintenance” procedures given throughout this manual and in component literature shipped with the furnace. Failure to perform the service and maintenance could result in damage to the furnace or system. Failure to follow the directions in this manual and component literature could result in severe personal injury, death or substantial property damage.

▲WARNING The furnace should be inspected and started annually, at the beginning of the heating season, only by a qualified service technician. In addition, the maintenance and care of the furnace designated in the table below, and explained on the following pages must be performed to assure maximum furnace efficiency and reliability. Failure to service and maintain the furnace and system could result in equipment failure.

▲WARNING This furnace contains fiberglass and ceramic fiber materials. These materials require special attention. Please refer to the WARNING and guidelines given on page 21. Failure to comply could result in severe personal injury, death or substantial property damage.

Service technician annual maintenance/start up (see following pages and burner manual for instructions)	
Service and maintenance	Annual start up
<p style="text-align: center;">Furnace and air system</p> <ul style="list-style-type: none"> <input type="checkbox"/> Consult with homeowner to see if there were any problems with furnace or system during the prior heating season (or cooling season) <input type="checkbox"/> Clean, inspect, and lubricate blower motor and wheel <input type="checkbox"/> Check condition of electrical wiring and tightness of terminals and connectors <input type="checkbox"/> Clean and inspect heat exchanger <input type="checkbox"/> Clean and inspect system accessories <p style="text-align: center;">Vent system</p> <ul style="list-style-type: none"> <input type="checkbox"/> Clean and inspect flue pipe, chimney/vent, and draft regulator <p style="text-align: center;">Fuel oil system</p> <ul style="list-style-type: none"> <input type="checkbox"/> Check oil tank and piping for leaks <input type="checkbox"/> Replace oil filter <p style="text-align: center;">Oil burner</p> <ul style="list-style-type: none"> <input type="checkbox"/> Clean and inspect oil burner assembly <input type="checkbox"/> Bleed system of air (single-pipe system) <input type="checkbox"/> Check oil pump pressures <input type="checkbox"/> Check combustion air ducts, grilles, etc. (if applicable) 	<p style="text-align: center;">Check operation</p> <ul style="list-style-type: none"> <input type="checkbox"/> Check sequence of operation <input type="checkbox"/> Check flame characteristics <input type="checkbox"/> Perform combustion checks/tests per burner manual and furnace manual <input type="checkbox"/> Check temperature rise <input type="checkbox"/> Check thermostat heat anticipator setting <input type="checkbox"/> Check safety controls (high-temperature limit switch, flame cutoff time, etc.)

Handling ceramic fiber and fiberglass materials

HANDLING OR REMOVAL OF COMBUSTION CHAMBER



The combustion chamber in this product contains ceramic fiber materials. Ceramic fiber can be converted to cristobalite in very high high temperature applications. The International Agency for Research on Cancer (IARC) has concluded, “Crystalline silica inhaled in the form of quartz or cristobalite from occupational sources is carcinogenic to humans (Group 1)”.

- Avoid breathing dust and contact with skin and eyes.
 - Use NIOSH certified dust respirator (N95). This type of respirator is based on the OSHA requirements for cristobalite at the time this document was written. Other types of respirators may be needed depending on the job site conditions. Current NIOSH recommendations can be found on the NIOSH web site at <http://www.cdc.gov/niosh/homepage.html>. NIOSH approved respirators, manufacturers, and phone numbers are also listed on this web site.
 - Wear long-sleeved, loose fitting clothing, gloves, and eye protection.
- Apply enough water to the combustion chamber lining to prevent airborne dust.
- Remove combustion chamber lining from the furnace and place it in a plastic bag for disposal.
- Wash potentially contaminated clothes separately from other clothing. Rinse clothes washer thoroughly.

NIOSH stated First Aid.

- Eye: Irrigate immediately
- Breathing: Fresh air.

HANDLING OR REMOVAL OF FIBERGLASS WOOL – OR – INSTALLATION OF FIBERGLASS WOOL OR COMBUSTION CHAMBER:



This product contains fiberglass jacket insulation and ceramic fiber materials in combustion chamber. Airbone fibers from these materials have been listed by the State of California as a possible cause of cancer through inhalation.

- Avoid breathing dust and contact with skin and eyes.
 - Use NIOSH certified dust respirator (N95). This type of respirator is based on the OSHA requirements for fiberglass wool at the time this document was written. Other types of respirators may be needed depending on the job site conditions. Current NIOSH recommendations can be found on the NIOSH web site at <http://www.cdc.gov/niosh/homepage.html>. NIOSH approved respirators, manufacturers, and phone numbers are also listed on this web site.
 - Wear long-sleeved, loose fitting clothing, gloves, and eye protection.
- Operations such as sawing, blowing, tear out, and spraying may generate airborne fiber concentration requiring additional protection.
- Wash potentially contaminated clothes separately from other clothing. Rinse clothes washer thoroughly.

NIOSH stated First Aid.

- Eye: Irrigate immediately
- Breathing: Fresh air.

10 Service and maintenance (continued)

Service/maintenance procedures

To lubricate and inspect blower motor

CAUTION DO NOT over-oil motors. Adding too much oil can damage the motor bearings, resulting in blower motor failure.

Belt-drive motor: Oil annually, using 3 drops of S.A.E. #10 oil (or other if specified by motor manufacturer). Blower bearings are permanently lubricated and do not require oiling. Verify that the blower, motor pulleys and belt are in good condition. Replace if necessary.

Direct-drive motor: Oil annually using 2 drops of S.A.E. #10 oil (or other if specified by motor manufacturer). Oiling is normally not required until the beginning of the third year of operation.

Clean blower wheel – Vacuum dust from blower wheel blades and surrounding area.

To clean heat exchanger

WARNING The heat exchanger must be cleaned and inspected at least once each year. Operating the furnace with a fouled or leaking heat exchanger could result in severe personal injury, death or substantial property damage.

WARNING The combustion chamber contains ceramic fiber materials. Wear a NIOSH-approved respirator while cleaning the furnace and follow WARNING on page 21 for proper handling.

1. Remove the burner and mounting plate.
2. Inspect the heat exchanger using a mirror inserted through the burner opening.
3. Using a brush on a flexible handle, loosen the soot on the inside of the heat exchanger.
4. Remove the soot with a vacuum.
5. See page 25 for locations. Remove the heat exchanger cleanout cover or flue collector box. Using a brush on a flexible handle, loosen the soot from the heat exchanger surfaces. Remove as much soot as possible using a vacuum.
6. Replace cleanout cover or flue collector box.
7. Re-install burner and mounting plate.

WARNING Obtain gas-tight seals at burner flange and cleanout plates to prevent possible flue gas leakage and carbon monoxide emissions, leading to severe personal injury or death.

Inspect vent system

Thoroughly inspect the entire vent system at least annually, including horizontal vent pipe and chimney or vertical vent. Ensure vent system is repaired or replaced if necessary before placing furnace in operation.

Oiled-bearing burner motors

The burner may need to be lubricated if the motor is equipped with oiling cups. Refer to burner manual for specific instructions. If instructed, apply a few drops only of S.A.E. 20 detergent oil (never use household oils). Do not attempt to “fill up” the oil cup. Over-oiling can damage the motor.

Optional Blocked vent shut off (BVSO) cleaning ←

For continued safe operation, the Blocked Vent Shut Off System (BVSO) is required to be inspected and maintained annually by a qualified agency.

1. Disconnect the power to the appliance;
2. Remove the two screws holding on the BVSO assembly cover;
3. Remove the cover;
4. Remove the two screws holding the thermal switch to the assembly base;
5. Without removing the electrical wires, remove the thermal switch and remove any build-up from the thermal switch surface;

CAUTION Do not dent or scratch the surface of the thermal switch. If the thermal switch is damaged, replacement is required.

6. Clear and remove any build-up or obstruction inside the heat transfer tube;
7. Re-mount the thermal switch to the assembly base;
8. Re-attach the assembly cover with the screws removed in step 2;
9. Re-establish power to the appliance.

10 Service and maintenance

(continued)

Annual start up

⚠ DANGER Follow information below to prevent severe personal injury, death or substantial property damage:

- Do not use gasoline, crankcase drainings or any oil containing gasoline. See burner manual for proper fuel oil.
- Do not attempt to start burner when excess oil has accumulated, when unit is full or vapor or when combustion chamber is very hot.
- Do not start burner unless collector box, vent and burner mounting door are secured in place.
- Never burn garbage or paper in the furnace.
- Never leave combustible material around it.

To start furnace

1. Factory burner adjustment and settings may not be suitable for specific job conditions. Refer to burner manual for burner start up, adjustment and checkout procedures.
2. Set room thermostat to call for heat.
3. Refer to burner manual for start up.
4. The furnace blower will delay for a short period after burner starts, until the Limit/Fan switch senses air temperature above the fan ON setting.
5. Set room thermostat to its lowest setting. Burner should turn off.
6. Furnace blower will continue to run until the Limit/Fan switch senses air temperature below the fan OFF setting.
7. Set the room thermostat to call for heat again. Allow furnace to heat to design temperature. Then adjust burner for correct combustion, using combustion test equipment. Adjust burner for:
Draft: -0.01" to -0.02" water column draft in furnace combustion chamber.
CO₂: between 10% and 11 ½ %, with 0 smoke.

⚠ WARNING Make final burner adjustments using combustion test equipment to assure proper operation.

8. Check furnace and duct system for proper operation and conditions.
9. Inspect vent system for proper operation.
10. To set Limit/Fan switch:
The blower operates until the air temperature drops below the fan OFF setting. If the air at the supply registers is too warm at blower start up or shutdown, lower the fan OFF and ON settings on the Limit/Fan switch.
To check operation of the limit switch, slide a piece of cardboard into the furnace filter slot. After a few minutes of operation (not more than 5 minutes), the burner should shut off (limit switch open). The blower will operate until the furnace cools down. Remove cardboard when finished.
11. Complete testing of the burner cad cell control using the instructions in the burner manual.

Components and Replacement Parts

11 Components and replacement parts

Figure 7 Model PMP-210 furnaces – Component locations

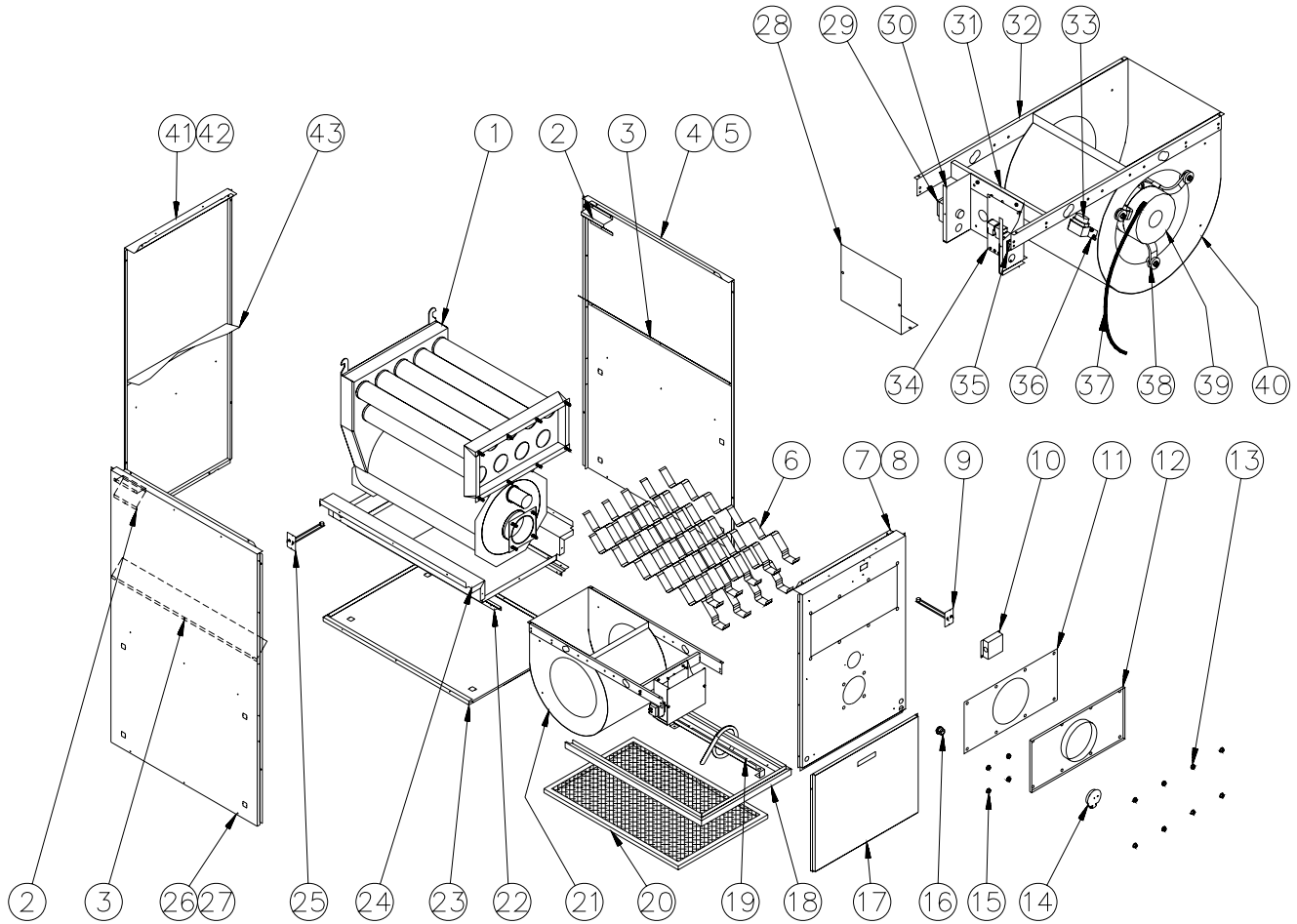

B50110 Rev.A

11 Components and replacement parts (continued)

Model PMP-210 furnaces – Replacement parts list

Item	Part description	Part number
1	Heat exchanger	B02800
2	Heat exchanger support	B02823
3	Side baffle	B02824
4	Right side panel assembly (insulation & baffle included)	B02791-03
5	Right side panel insulation	B02815
6	Heat exchanger baffle (9 required)	B02808
7	Front panel assembly (insulation & labels included)	B02786-03
8	Front panel insulation	B02817
9	Limit Control 195-30F	R02R004
10	Limit Control cover	B02826-01
11	Gasket, smoke box	B02714
12	Smoke box cover	B02799-01
13	Hexagonal nut 3/8-16NC brass	F07O001
14	Observation door	B02111
15	Hexagonal nut 3/8-16NC zinc	F07F011
16	Strain relief bushing SR-7W-2	L04I011
17	Front bottom panel assembly (handle and labels included)	B02787-03
18	Filter rack "U" frame	B01809-01
19	Filter rack access	B01808-01
20	Paper filter 20 x 30 x 1	Obtain locally
21	Blower assembly complete (motor and capacitor included)	B01406-01
22	Blower slide support	B01794

Item	Part description	Part number
23	Floor	B02820
24	Divider panel	B02788
25	Limit Control 140-20F	R02R002
26	Left side panel assembly (insulation & baffle included)	B02791-04
27	Left side panel insulation	B02815
28	Electrical box cover	B01684
29	Transformer 120/24 VAC	L01F009
30	Electrical box (only)	B01683
31	Electrical box holder plate	B01682
32	Blower slides	B01681
33	15 MF capacitor	L01I005
34A	Electronic fan timer	R99G004
34B	Electrical wire harness (board)	B02797
35	Rocker switch SPST	L07F003
36	Capacitor holder	B01024
37	Electrical wire harness (blower)	B00202
38	Motor mount assembly (band, legs, nut & bolts included)	B01889
39	3/4 HP direct drive motor (without motor support)	L06I004
40	Blower 120-10T (wheel and housing)	B03720-05
41	Back panel assembly (insulation & baffle included)	B02792-01
42	Back panel insulation	B02813
43	Rear baffle	B02825

12 Dimensions and ratings

Figure 8 Model PMP-210 dimensional data – ALL DIMENSIONS IN INCHES

Model	Furnace casing			Warm air supply (top)		Return air (side)		Flue pipe diam.
	Width	Depth	Height	Width	Depth	Width	Depth	
	A	B	C	J	K	R	S	
PMP-210	24	34	53	22	30	18	28	7

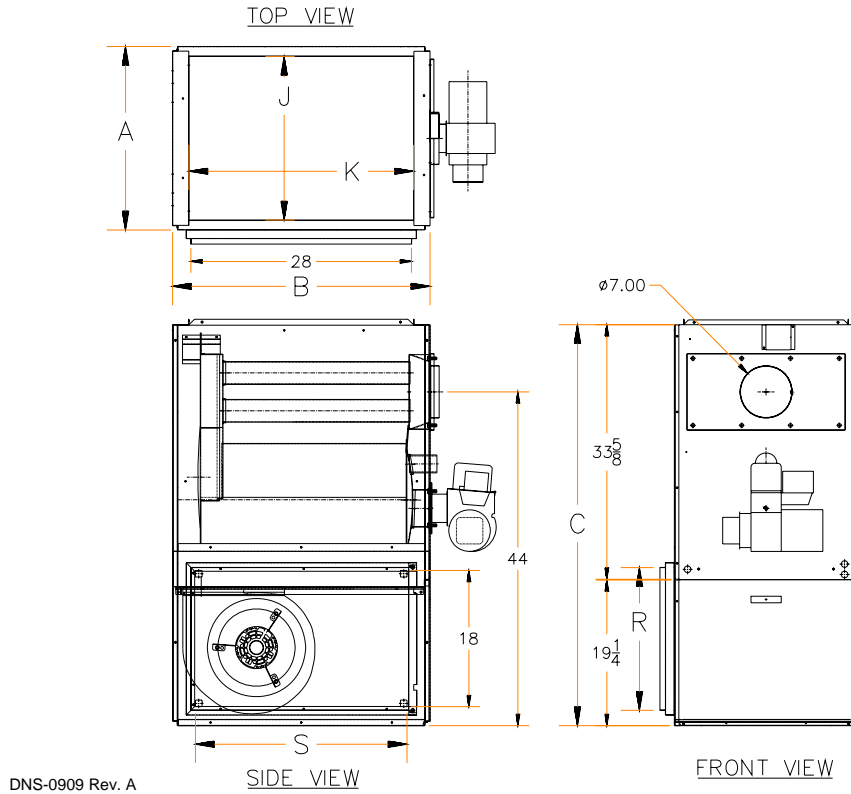

Model	Input (BTU/h)	Output (BTU/h)	Firing rate (GPH)	Installed nozzle	AFUE	Blower size	Blower motor hp	Blower speed		Maximum cooling capacity (tons)	Blower CFM	
								@ 0.25" WC	@ 0.50" WC		@ 0.25" WC	@ 0.50" WC
Direct-drive units												
PMP-210	168,000	142,000	1.20		84.3	GT12-10	3/4	Med.- High	High	5	2200	2150
	189,000	158,000	1.35		83.6	GT12-10	3/4	High	High	5	2200	2150
	210,000	175,000	1.50	✓	82.9	GT12-10	3/4	High	High	5	2300	2150

Model	Maximum heating temperature rise (°F)	Filter quantity and size	Volt - Hertz - Phase	Electrical load (amps)	Minimum ampacity for wiring sizing	Maximum fuse size (amps)	Ship weight (pounds)
PMP-210	65 - 85	(1) 20 X 30	115 - 60 - 1	15.7	18.1	20.0	250

12 Dimensions and ratings

Model PMP-210, Burner data

BECKETT BURNER - Model AFG (3450 RPM) - Tube insertion 2 7/8"

Model	Input BTU/h	Firing rate USGPH	Nozzle (Delavan)	Pump pressure (PSIG)	Head	Low firing rate baffle	Static disc	Combustion air adjustment (band/shutter)
PMP-210	168,000	1.20	1.00 - 80B	145	F6	No	2 3/4" (#3383)	0 / 6
	189,000	1.35	1.10 - 80B	150	F6	No	2 3/4" (#3383)	1 / 3
	210,000	1.50	1.25 - 80B	145	F6	No	2 3/4" (#3383)	1 / 5

RIELLO BURNER - Model 40-F5 - Tube insertion 3 9/16"

Model	Input BTU/h	Firing rate USGPH	Nozzle (Delavan)	Pump pressure (PSIG)	Combustion air adjustment (turbulator/band)
PMP-210	168,000	1.20	1.00 - 70W	145	0 / 3
	189,000	1.35	1.10 - 70W	150	1 / 3.25
	210,000	1.50	1.25 - 70W	145	4 / 4

CARLIN BURNER - EZ-1 - Tube insertion 2-1/2"

Model	Input BTU/h	Firing rate USGPH	Nozzle (Delavan)	Pump pressure (PSIG)	Head Setting "A"	Air Setting
PMP-210	168,000	1,20	1.20 - 60B	100	1.10 / 1.25	1.10
	189,000	1,35	1.35 - 60B	100	1.35 / 1.50	1.35
	210,000	1,50	1.50 - 60B	100	1.35 / 1.50	1.50

Airflow data (CFM)

Model	Blower speed	External static pressure						
		0.1"	0.2"	0.3"	0.4"	0.5"	0.6"	0.7"
PMP-210	Med-High	2230	2210	2190	2170	2150	2110	2070
	High	2390	2330	2270	2210	2150	2110	2070

Notes :

Airflow values in cubic ft per minute (CFM) rounded to nearest 5 CFM.

Data taken with filters in place.

13 Owner's information

The furnace must be inspected and started ANNUALLY, at the beginning of the heating season, only by a qualified service technician.

The service technician must perform annual service and maintenance on the furnace to ensure reliable operation. Failure to service and maintain the furnace and system could result in equipment failure, causing severe personal injury, death or substantial property damage.

As the owner, you need to be aware of the following needs of your furnace. You must inspect and clean or replace the furnace filter monthly, as described below, and perform the other inspection procedures as well. Failure to maintain a clean filter will result in unsatisfactory cycling of the furnace and could lead to a no-heat condition. Failure to perform this maintenance could result in substantial property damage.

Follow all of the procedures below. Failure to comply could result in severe personal injury, death or substantial property damage.

Operating the furnace

1. The furnace should operate automatically on call for heat from the room thermostat.
2. If the furnace oil burner should shut down on flame failure, the burner primary control will lock out. Ask your service technician to show you the correct procedure to reset the primary control button. NEVER push the button more than once in an attempt to start the burner after lockout. Continued lockout of the control means something is wrong with the burner, controls or oil system. The condition must be corrected by a qualified service technician.

Daily inspection

1. Verify there are no combustible materials in the furnace room or near the furnace.
2. Verify the air openings to the furnace room are not obstructed in any way.
3. Verify the furnace seems to be operating normally. Notify your service technician immediately if you notice any abnormal behavior.

Monthly – inspect and clean/replace filter

1. Ask your service technician to show you the correct way to remove and clean your furnace filter. Replace the filter if you are unable to thoroughly clean it.

To shut down furnace

1. Set the room thermostat to its lowest setting.
2. Turn off the disconnect switch in the 120-VAC power line to the furnace.
3. If the burner will be shut down for an extended time, tightly close all oil valves.
4. Refer to burner manual for any additional instructions.

