

CLICK ANYWHERE on THIS PAGE to RETURN TO WILLIAMS GAS WILLIAMS OIL-O-MATIC & WILLIAMSON MANUALS at InspectApedia.com

FreeStyle®

Wall Mount Gas-Fired Condensing Boilers Combi & Heat Only Models 80/120/155



* Low Lead Content

Boiler Manual

- Installation
- Maintenance
- Startup
- Parts



Quick Start
Guide
Pages 3 & 4

Available in Combi or Heating Only models

* CSA - Low Lead Content only applies to the Combi model



WARNING This manual must only be used by a **qualified heating installer/service technician**. Failure to comply could result in severe personal injury, death or substantial property damage.



NOTICE When calling or writing about the boiler— Please have: • boiler model number from the boiler rating label.

Contents

Page

1 Quick Start Guide — using default settings 3

2 Prepare boiler location 6

3 Prepare boiler 8

4 Converting boiler to propane 12

5 Gas piping — sizing gas lines 16

6 Venting/air piping — general. 17

7 Commonwealth of Massachusetts installations 20

8 Vent termination requirements. 21

9 Boiler room air openings. 22

10 DIRECT VENT — Sidewall with separate pipes 23

11 DIRECT VENT — Sidewall concentric 25

12 DIRECT VENT — Vertical with separate pipes. 27

13 DIRECT VENT — Vertical concentric. 29

14 Concentric termination, typical (sidewall or vertical) 31

15 Vent and air piping and boiler connections 32

16 Install water piping 35

Domestic Water Piping – Combi Boiler 35

17 Primary/Secondary System Piping 37

System water piping methods 37

Expansion Tank Location 37

Diaphragm- or bladder-type tank: 37

Closed-type expansion tank: 39

Install relief valve 40

Zone Valve zoning – primary/secondary 41

Circulator zoning – primary/secondary 42

Circulator zoning – Multiple temperature zones with primary/secondary 43

18 Multiple boiler installations 44

19 Install condensate line 47

20 Gas piping 48

21 Field wiring. 50

22 Wiring diagram — FS-80/120 Combi Ladder. 52

22 Wiring diagram — FS-80/120 Combi Schematic. 53

23 Wiring diagram — FS-80/120 Heating Only Ladder 54

23 Wiring diagram — FS-80/120 Heating Only Schematic 55

23 Wiring diagram — FS-155 Combi Ladder 56

23 Wiring diagram — FS-155 Combi Schematic 57

23 Wiring diagram — FS-155 Heating Only Ladder. 58

23 Wiring diagram — FS- 155 Heating Only Schematic 59

24 Controls and operation 60

25 DHW Settings (Combi Only). 65

26 High Altitude 66

27 Startup 67

28 Startup — final checks 69

29 Check-out/startup verification 75

30 Annual startup and general maintenance 76

31 Annual startup 77

32 Troubleshooting 81

33 Maintenance 103

34 Replacement parts 112

35 Dimensions and connections data 124

36 Engineering Data 126

37 Ratings 127

38 Installation and Service Certificate. 128

Hazard definitions

⚠ DANGER Hazards that **will cause severe** personal injury, death or substantial property damage.

⚠ CAUTION Hazards that **will or can cause minor** personal injury or property damage.

⚠ WARNING Hazards that **can cause severe** personal injury, death or substantial property damage.

NOTICE Special instructions on installation, operation or maintenance that are important but not related to personal injury or property damage.

⚠ WARNING **INSTALLER** — Read all instructions before installing. **Read page 3 first.** Follow all instructions in proper order to prevent personal injury or death.

- Consider piping and installation when determining boiler location.
- Any claims for damage or shortage in shipment must be filed immediately against the transportation company by the consignee.

⚠ WARNING **USER** — Please read the following. Failure to comply could result in severe personal injury, death or substantial property damage.

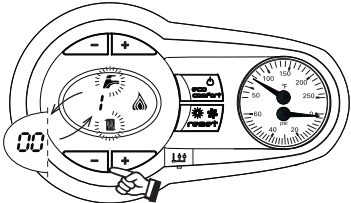
- **This manual is for use only by your qualified heating installer/service technician.**
- Please see the User's Information Manual for your reference.
- Have the boiler serviced by a qualified service technician, at least annually.

1 Quick Start Guide — using default settings

Figure 1 Quick Start Guide - Default control settings, see instructions and figures on pages 60-65).

QUICK START GUIDE		
<p>After you have completed the installation of the FreeStyle® Boiler (Combi or Central Heating only models) by the instructions provided in the manual, pages 5-71 insure the following first before you proceed:</p> <p>All gas lines are connected and tested for leaks, and if the boiler is to operate on LP fuel, and the unit has been converted properly from Natural gas to Liquefied Petroleum (Propane) gas and set up as directed in the boiler manual.</p> <p>All water piping, heating (and domestic if a Combi boiler) is installed correctly and free of leaks with the proper accessories; proper sized expansion tank, water feed valve adjusted, low water cut-off devices installed and tested, all operation control exterior to the boiler installed such as thermostats, and zone control panels.</p> <ul style="list-style-type: none"> • Sentinel X100 Inhibitor has been added and the water has been checked with the supplied test kit. • Condensate trap has been filled with water. • Electrical connection for the boiler is grounded and has correct polarity. • Venting and Intake Air Piping is all secure, sealed and installed as instructed in the boiler manual. • Central Heating only boilers, outdoor sensor MUST be installed and connected to the boiler control. (See boiler manual) 		
System start		
1	Push ECO / Comfort / Power button; to start boiler	<input type="checkbox"/>
2	NOTE: if A-16 error code is displayed (Central Heating Only boiler) when unit is powered up, the outdoor sensor is not installed. Install outdoor sensor and push the reset button to reset error code. A faulty outdoor sensor will give an "F-39" error code. The outdoor sensor must be installed unless specifically exempted in the Energy Act statement on page 127.	<input type="checkbox"/>
3	03 "shows on the display" (control software version)	<input type="checkbox"/>
4	FH "shows on the display" (Fan /inducer operating in purge mode of combustion chamber and venting for 5 minutes).	<input type="checkbox"/>
5	With no "call for heat" (current boiler water temperature will be shown in degrees F).	<input type="checkbox"/>
6	To Change "Central Heating water temperature set-point" (from 68 F to 194 degrees F) use the bottom set of "+" or "-" keys to raise or lower the set point temperature.	<input type="checkbox"/>
7	To change "Domestic water temperature set-point" (Combi Boiler) (from 104 F to 131 degrees F) NOTE: Insure that operating temperature is a safe set-point temperature. Use the top set of "+" or "-" keys to raise or lower the set point.	<input type="checkbox"/>

1 Quick Start Guide — using default settings

QUICK START GUIDE	
System start <i>(continued)</i>	
8	<p>“Test Mode Operation”</p> <p>Proceed to put the boiler into operation as follows:</p> <ol style="list-style-type: none"> To operate the boiler in test mode, press the CH “-” and “+” keys together for 5 seconds (See below and Figure 95, page 70) to activate the TEST mode. The boiler lights at the maximum heating 100% rate displayed on the LCD display.  <ol style="list-style-type: none"> The high fire (large) flame symbol will be displayed once the boiler has lit. Use DHW “_” button to drop firing rate to low fire. To exit the “Test mode”, press the CH keys (Items 3 and 4 Figure 74, page 60) together for 5 seconds, or leave the boiler to automatically switch off after 15 minutes or stopping DHW flow. This TEST procedure is used to check/adjust combustion CO and CO₂ per specifications, Figure 98, page 73 and Figure 101, page 74.
Liquefied Petroleum (Propane) Gas — Propane conversion kit (optional - sold separately, see Figure 152, page 112 .	
High altitude — High altitude (over 4,500 feet) requires only changing the altitude setting on the control.	
Equipment that maybe required for installation	
	Digital or U-tube manometer for checking gas line pressure <input type="checkbox"/>
	Volt-ohmmeter may be required for troubleshooting
	Combustion Analyzer to verify and adjust combustion <input type="checkbox"/>

▲WARNING This unit must only be used for its intended purpose. This unit is designed to heat water to a temperature below boiling point and must be connected to a heating system and/or a water supply system for domestic use, compatible with its performance, characteristics and heating capacity. Any other use is deemed improper.

Incorrect installation can cause damage or injury for which the manufacturer cannot be deemed responsible.

▲WARNING The boiler contains ceramic fiber and fiberglass materials. Use care when handling these materials per instructions on page 77 of this manual. Failure to comply could result in severe personal injury.

Pay attention when handling the boiler insulation panels as they contain materials that could irritate the skin. No part of the boiler contains asbestos, mercury or Chlorofluorocarbons (CFC's).

Please read before proceeding

⚠ WARNING

Installer— Read all instructions, including this manual and all other information shipped with the boiler, before installing. Perform steps in the order given.

User — This manual is for use only by a qualified heating installer/service technician. Refer to User's Information Manual for your reference.

User — Have this boiler serviced/inspected by a qualified service technician, at least annually.

Failure to comply with the above could result in severe personal injury, death or substantial property damage.

NOTICE

Write in the CP number in the space provided on the Installation certificate on page 128 if not already shown.

When calling or writing about the boiler— Please have the boiler model number from the boiler rating label and the CP number from the boiler jacket.

Consider piping and installation when determining boiler location.

Any claims for damage or shortage in shipment must be filed immediately against the transportation company by the consignee.

⚠ DANGER

If any part of a boiler, burner or its controls has been sprayed with or submerged under water, either partially or fully, DO NOT attempt to operate the boiler until the boiler has been either replaced or completely repaired, inspected, and you are sure that the boiler and all components are in good condition and fully reliable.

Otherwise, by operating this boiler, you will cause a fire or explosion hazard, and an electrical shock hazard, leading to serious injury, death, or substantial property damage. See the instructions at right.

Saltwater Damage — The exposure of boiler components to saltwater can have both immediate and long-term effects. While the immediate effects of saltwater damage are similar to those of freshwater (shorting out of electrical components, washing out of critical lubricants, etc.), the salt and other contaminants left behind can lead to longer term issues after the water is gone due to the conductive and corrosive nature of the salt residue. Therefore, Williamson-Thermoflo equipment contaminated with saltwater or polluted water will no longer be covered under warranty and should be replaced.

Electrical Damage — If any **electrical component** or **wiring** came into contact with water, or was suspected to have come into contact with water, replace the boiler with a new Williamson-Thermoflo boiler.

⚠ WARNING

Failure to adhere to the guidelines below can result in severe personal injury, death or substantial property damage.

When servicing boiler —

- To avoid electric shock, disconnect all electrical supplies to the boiler before performing maintenance.
- To avoid severe burns, allow boiler to cool before performing maintenance.
- This boiler contains ceramic fiber and fiberglass materials. Refer to the WARNING and instructions on page 77.

Boiler operation —

- Do not block flow of combustion or ventilation air to boiler.
- Should overheating occur or gas supply fail to shut off, do not turn off or disconnect electrical supply to pump. Instead, shut off the gas supply at a location external to the appliance.

Combustion air —

- DO NOT install combustion air intake where there is a risk of combustion air contamination.

Carbon monoxide detector —

- A carbon monoxide detector that is wired on the same electrical circuit as the boiler is strongly recommended.

SURGE PROTECTOR —

- Provide surge protection in the boiler power supply. This will reduce the pos-

sibility of damage to the boiler control.

*In some locations, a carbon monoxide detector is required by the law.

Boiler water —

- The FreeStyle heat exchanger is made of stainless steel, and requires that system water chemistry be within the limits in this manual. Use the Sentinel X100 inhibitorsupplied with the boiler. **ADDITIONAL CHEMICAL TREATMENT MAY BE NECESSARY.** See page 67 for details.
- Thoroughly flush the system (**BEFORE** connecting boiler) to remove sediment. The high-efficiency heat exchanger can be damaged by build-up or corrosion due to sediment.
- Do not use petroleum-based cleaning or sealing compounds in boiler system. Gaskets and seals in the system may be damaged. This can result in substantial property damage.
- Continual fresh make-up water will reduce boiler life. Mineral buildup in eat exchanger reduces heat transfer, overheats the aluminum heat exchanger, and causes failure. Addition of oxygen carried in by make-up water can cause internal corrosion. Leaks in boiler or piping must be repaired at once to

prevent make-up water. Use this boiler **ONLY** in a closed-loop system.

- Do not add cold water to a hot boiler. Thermal shock can cause heat exchanger to crack.

Freeze protection fluids —

- NEVER use automotive or standard glycol antifreeze. Use only freeze-protection fluids made for hydronic systems. Follow all guidelines given by the anti-freeze manufacturer. Thoroughly clean and flush any replacement boiler system that has used glycol before installing the new boiler Use only the products listed by Williamson-Thermoflo for use with this boiler. See page 113 for details.

⚠ CAUTION

Frozen Water Damage Hazard

Residences or buildings that are unattended in severely cold weather, boiler system components failures, power outages, or other electrical system failures could result in frozen plumbing and water damage in a matter of hours. For your protection, take preventative actions such as having a security system installed that operates during power outages, senses low temperature, and initiates an effective action. Consult with your boiler contractor or a home security agency.

Commonwealth of Massachusetts

When the boiler is installed within the Commonwealth of Massachusetts:

- This product must be installed by a licensed plumber or gas fitter.
- If antifreeze is used, a reduced pressure back-flow preventer device shall be used.
- Sidewall vent air installations — see instruction on page 20.

2 Prepare boiler location

Codes & checklist

Installations must comply with:

- Local, state, provincial, and national codes, laws, regulations and ordinances.
- National Fuel Gas Code, ANSI Z223.1/NFPA 54.
- National Electrical Code.

Certification

NOTICE

The FreeStyle® boiler gas manifold and controls meet safe lighting and other performance criteria when boiler underwent tests specified in ANSI Z21.13 — latest edition.

Flooring

1. The boiler **must not** be installed on carpeting.

WARNING

Do not install boiler on carpeting even if foundation is used. Fire can result, causing severe personal injury, death or substantial property damage.

Before locating the boiler:

1. Wall construction — Make sure the wall construction is suitable to carry the weight of the boiler and components. See page 9 for instructions.
2. The boiler is suitable for INDOOR installation only.
3. Check for nearby connection to:
 - System water piping
 - Venting connections
 - Gas supply piping
 - Electrical power
 - Condensate drain
4. Check area around boiler. Remove any combustible materials, gasoline and other flammable liquids.

WARNING

Failure to keep boiler area clear and free of combustible materials, gasoline and other flammable liquids and vapors can result in severe personal injury, death or substantial property damage.

5. The FreeStyle® boiler must be installed so that gas control system components are protected from dripping or spraying water or rain during operation or service.
6. If new boiler will replace existing boiler, check for and correct system problems, such as:
 - Sediment or corrosion in system piping — clean and flush piping BEFORE connecting the new boiler. See page 67.
 - System leaks causing oxygen corrosion or heat exchanger cracks from hard water deposits.
 - Incorrectly-sized expansion tank.
 - Lack of freeze protection in boiler water causing system and boiler to freeze and leak.

Residential garage installation

Precautions

1. Take the following special precautions when installing the boiler in a residential garage. If the boiler is located in a residential garage:
 - Mount the boiler with its bottom at least 18 inches above the floor. This complies with the National Fuel Gas Code, ANSI Z223.1 for U. S. installations, or CSA B149.1.

- Locate or protect the boiler so it cannot be damaged by a moving vehicle.
- Ensure that the installation complies with all applicable codes.
- Prevent boiler water and condensate from freezing.

Provide air openings to room

FreeStyle® boiler alone in boiler room

1. No air ventilation openings into boiler room are needed if clearances around FreeStyle® boiler are at least equal to the SERVICE clearances shown in Figure 2, page 7.
2. For spaces that DO NOT supply the minimum service clearances, provide two openings as shown in Figure 2, page 7. Each opening must provide 1 square inch free area per 1,000 Btuh of boiler input.

FreeStyle® boiler in same space with other gas or oil-fired appliances

1. Follow the sizing requirements shown in Figure 23, page 22.

WARNING

The space must be provided with combustion/ventilation air openings correctly sized for all appliances located in the same space as the FreeStyle® boiler.

Reinstall boiler jacket door after servicing. The boiler jacket door must be securely fastened to the boiler to prevent boiler from drawing air from inside the boiler room. This is particularly important if the boiler is located in the same room as other appliances.

Failure to comply with the above warnings could result in severe personal injury, death or substantial property damage.

Vent and air piping

1. The FreeStyle® boiler requires a special vent system, designed for pressurized venting. FreeStyle® boilers are rated ANSI Z21.13 Direct Vent (pressurized vent, likely to condense in the vent). See instructions beginning on page 17.
2. You must also install air piping from outside to the boiler air intake adapter. The resultant installation is categorized as direct vent (sealed combustion). Note prevention of combustion air contamination on page 8 when considering vent/air termination.
3. Vent and air must terminate near one another unless otherwise specified in this manual. Vent and air piping may be routed vertically through the roof or out a side wall, following the options give in this manual. You may use any of the vent/air piping methods covered in this manual. Do not attempt to install the FreeStyle® boiler using any other means.
4. Be sure to locate the boiler such that the vent and air piping can be routed through the building and properly terminated. The vent/air piping lengths, routing and termination method must all comply with the methods and limits in instructions beginning on page 17.

2 Prepare boiler location continued

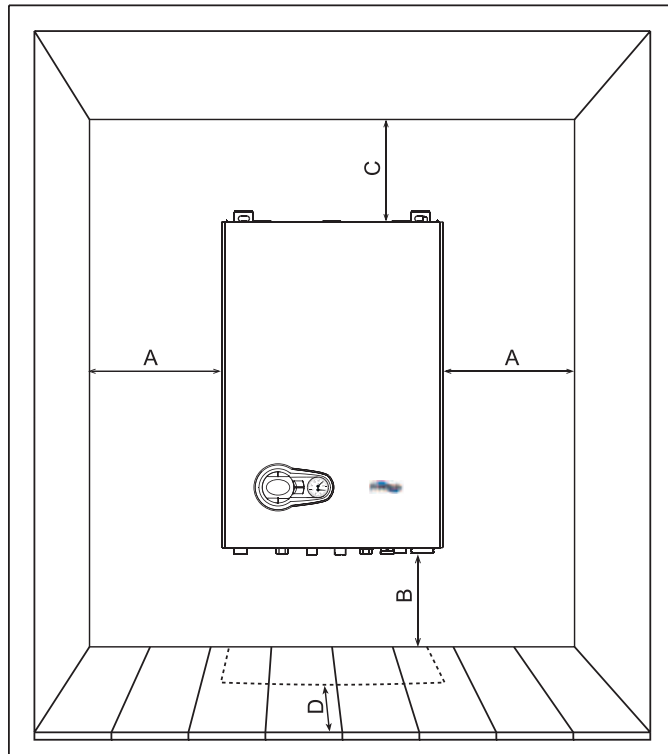
Clearances

Provide clearances from combustibles materials — REQUIRED

1. See Figure 2 for REQUIRED minimum clearances. ALL installation must provide at least these minimums.
2. Hot water pipes — at least 1/2" from combustibles.
3. Vent pipe — at least 3/16" from combustibles.
4. See Figure 1 for service clearance minimums.

NOTICE If the unit is enclosed in a cabinet or mounted alongside, a space must be provided for removing the casing and for normal maintenance operations. The minimum measurements to be respected are given in Figure 2.

Figure 2 REQUIRED minimum clearances (all dimensions are in inches)



Minimum required for Combustion	A	Minimum 1.00"
	B	Minimum 12.00"
	C	Minimum 12.00"
	D	Minimum 12.00"
Recommended for Service	A	Minimum 36.00"
	B	Minimum 36.00"
	C	Minimum 24.00"
	D	Minimum 36.00"

A Provide combustion air/ventilation openings per Figure 23, page 22 or as otherwise directed in this manual or by applicable codes.

NOTICE If the installation does not provide the minimum clearances, then the enclosure **MUST HAVE** air openings located per Figure 2, above. Each of these air openings must have free area of at least 1 square inch per 1,000 MBH of boiler input.

B Left side clearance to combustibles = 1.0 inches minimum

C Top of boiler clearance to combustibles = 12.0 inches minimum

D Right side clearance to combustibles = 1.0 inches minimum

E Bottom of boiler clearance to combustibles = 12 inches minimum (must be 18 inches above floor for garage installations)

F Clearance in front of the boiler = 12.0 inches, but **36 inches minimum required for service**

H Vent pipe must be minimum 3/16 inch from combustibles. Opening in combustible wall, floor, ceiling or roof must be 3/8" larger than flue pipe diameter, fitted with galvanized steel thimble, or larger if required by codes or as specified by vent pipe manufacturer.

NOTICE ADDITIONAL service clearance may be needed, depending on how piping is routed to the boiler.

Provide clearances for service access — RECOMMENDED

1. See Figure 2, for recommended service clearances.
2. If you do not provide minimum service clearances shown, it might not be possible to service the boiler without removing it from the space.
3. Clearance D, Figure 2 allows for the installation of piping as shown in Figure 6, page 11, plus a union, close nipple and elbow.

A Provide combustion air/ventilation openings per Figure 23, page 22 or as otherwise directed in this manual or by applicable codes. **NOTE:** If the installation does not provide the minimum clearances in this illustration, then the enclosure must have air openings located and sized per Figure 2.

B Left side service clearance = 36 inches minimum

C Service clearance above top of boiler = 24 inches minimum

D Right side service clearance = 24 inches minimum

E Service clearance below the boiler = 36 inches minimum

F Service clearance in front of the boiler = 36 inches minimum

2 Prepare boiler location continued

Air contamination

Please review the following information on potential combustion air contamination problems.

See **Table 1** for products and areas which may cause contaminated combustion air.

WARNING To prevent potential of severe personal injury or death, check for products or areas listed below before installing boiler. If any of these contaminants are found:

- remove contaminants permanently.
- OR —
- isolate boiler and provide outside combustion air. See national, provincial or local codes for further information.

Table 1 Corrosive contaminants and likely location

Products to avoid
Spray cans containing chloro/fluorocarbons
Permanent wave solutions
Chlorinated waxes/cleaners
Chlorine-based swimming pool chemicals
Calcium chloride used for thawing
Sodium chloride used for water softening
Refrigerant leaks
Paint or varnish removers
Hydrochloric acid/muriatic acid
Cements and glues
Antistatic fabric softeners used in clothes dryers
Chlorine-type bleaches, detergents, and cleaning solvents found in household laundry rooms
Adhesives used to fasten building products and other similar products
Excessive dust and dirt

Areas likely to have contaminants
Dry cleaning/laundry areas and establishments
Swimming pools
Metal fabrication plants
Beauty shops
Refrigeration repair shops
Photo processing plants
Auto body shops
Plastic manufacturing plants
Furniture refinishing areas and establishments
New building construction
Remodeling areas
Garages with workshops

WARNING You must pipe combustion air to the boiler air intake.

Install air inlet piping for the FreeStyle® boiler as described in this manual.

The air termination fitting must be installed with the clearances and geometry relative to the vent outlet depicted in this manual to ensure that flue products do not enter the air intake.

Ensure that the combustion air will not contain any of the contaminants in Table 1. Do not pipe combustion air near a swimming pool, for example. Avoid areas subject to exhaust fumes from laundry facilities. These areas will always contain contaminants.

Contaminated combustion air will damage the boiler, resulting in possible severe personal injury, death or substantial property damage.

3 Prepare boiler

Remove boiler from crate

WARNING The boiler is heavy. Use caution not to drop the boiler or cause bodily injury while lifting and handling. Verify that the boiler is securely attached to prevent possibility of boiler falling after installation.

WARNING Do not drop boiler or bump jacket on floor or pallet. Damage to boiler can result.

CAUTION Cold weather handling — If boiler has been stored in a very cold location (below 0°F) before installation, handle with care until the plastic components come to room temperature.

1. The boiler is generally easier to handle and maneuver after removing the shipping container.
2. **Leave the boiler resting on the styrofoam protective base and bottom cardboard cap, until ready to place on the wall.**

NOTICE The boiler is arranged and designed for wall mounting and comes standard with a hanging bracket. The wall fixture must ensure stable and effective support for the boiler.

3 Prepare boiler continued

Wall-mounting requirements

⚠ WARNING DO NOT attempt to attach the wall mount bracket using anchors or any means other than directly securing to the wall studs (or equivalent wood structure if studs are not on 16-inch centers).

The wall must be vertically plumb and capable of carrying the weight of the boiler and any attached piping components.

The operating weight for wall-mountable boilers are:

FreeStyle® 80:	70 pounds
FreeStyle® 120:	80 pounds
FreeStyle® 155:	87 pounds

⚠ WARNING Failure to comply with above and the procedure given below could result in severe personal injury, death or substantial property damage.

1. Stud spacing: Bracket holes are spaced for studs on 16-inch centers. For other stud spacing, provide secure, solid mounting surface on which to attach the boiler wall-mounting bracket.
2. Wood stud wall: Install bracket with lag screws (3/8" x 3") included in kit, only into the studs.
3. Metal stud wall: Secure bracket and spacer board to studs with 3/16-inch toggle bolts and 3/16-inch flat washers (not included with kit).
4. Concrete or block wall: Secure wall bracket with approved bolts for that application.

⚠ WARNING Verify that the studs are suitable for carrying a wall-mounted load. Some metal studs are not designed for this purpose.

5. If the mounting wall has exposed studs, installer must provide a backer board to mount boiler. Boiler cannot be leveled without a backing surface.
6. Mount the boiler on the wall following these instructions. The boiler mounting studs must engage with the wall-mount bracket. Make sure the bracket is not just resting on the edge of the mounting stud or washer. Perform all procedures given in the Boiler Manual on previous pages before mounting the boiler.

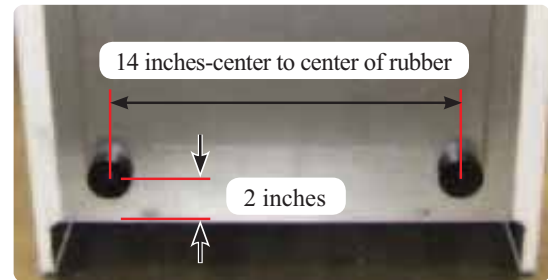
Install rubber bumpers to back of boiler

1. Remove supplied rubber bumpers from plastic bag and measure across 14 inches, and up 2 inches from the back of the boiler bottom edge. Mark these two locations, and peel off adhesive protection from the rubber bumpers, and mount the two according to the directions in Figure 3.
2. DO NOT drill holes to mount the rubber bumpers

Install the wall-mount bracket

1. Locate the studs — must be on 16-inch centers. See previous instructions if studs are not on 16-inch centers.
2. Place the wall-mount bracket Figure 4, below on the wall, using a level to align correctly.
3. Place the wall-mount bracket so the mounting slots are centered over the studs.
4. Level the bracket and trace the outline of the screw slots with a pencil.

Figure 3 Addition of rubber bumper for wall mounting



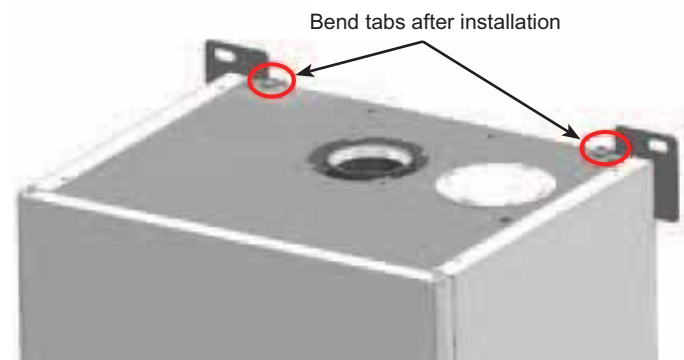
5. Remove the mounting bracket and drill holes 1/4" diameter by 3 inches deep, centered on the screw slot outlines. (For metal stud walls, using 3/16" toggle bolts, drill required clearance holes.)

Figure 4 Wall mount bracket



6. Position the wall-mount bracket on the wall. Insert and loosely tighten the two (2) lag screws (or toggle bolts for metal studs).
7. Level the wall-mounting bracket. Then tighten lag screws securely. For drywall or plaster lathe installations, avoid tightening so much that the bracket digs into the wall surface.

Figure 5 Wall mount bracket tabs bend over boiler to secure boiler in place



Place boiler on bracket

1. The wall-mount bracket must be installed before mounting the boiler.
2. After installing the boiler on the mounting bracket, bend down the two (2) tabs in order to secure boiler in place, see Figure 5.

3 Prepare boiler continued

Hydrostatic pressure test

▲WARNING DO NOT install a relief valve with a pressure higher than 30 PSIG. This is the maximum allowable relief valve setting for the FreeStyle® boiler. Failure to comply could prevent the relief valve from operating as needed, resulting in possibility of severe personal injury, death or substantial property damage.

▲WARNING Use two wrenches when tightening any pipe connection to the boiler. Failure to prevent the boiler pipes from turning could damage pipes or heat exchanger, resulting in possible severe personal injury, death or substantial property damage.

Pressure test the boiler before permanently attaching water or gas piping or electrical supply.

Install pipe fittings for relief valve and P/T gauge

1. Install the reducing tees, and close nipples, field supplied, located and oriented as shown in Figure 6, page 11. Apply pipe dope to all fittings sparingly.

▲WARNING DO NOT install the relief valve until after the hydrostatic test. Temporarily install a ¾" pipe plug in the relief valve location as directed in these instructions. The plug must be removed after the test.

▲WARNING Connect the relief valve ONLY on the BOILER SUPPLY OUTLET, NOT the boiler return. Connect the relief valve only as shown in this manual. Ensure relief valve is located above heat exchanger. Failure to comply with the above could prevent the relief valve from operating as needed, resulting in possibility of severe personal injury, death or substantial property damage.

2. Install the test pressure/temperature gauge (field supplied) to the reducing tee as shown in Figure 7, page 11.

Install fittings and valves required for hydrostatic testing (supplied by installer)

1. The following piping components (supplied by installer) are required for the test configuration:
 - a. Two shut-off valves (¾" NPT on FS-80/120, 1" NPT on FS-155).
 - b. Two close nipples (¾" NPT on FS-80/120, 1" NPT on FS-155).
 - c. ¾" NPT pipe plug.
 - d. Pressure/temperature gauge.
 - e. ¾" NPT boiler drain valve.
2. **TEMPORARILY** insert a ¾" NPT pipe plug in the relief valve tapping. After the hydrostatic test, this plug **must** be removed and the relief valve must be installed.

Fill and pressure test

1. See Figure 6, page 11, for use with the following instructions.
2. CLOSE the boiler drain valve (item 10). Connect a hose to fresh water supply and to the drain valve.
3. Place a bucket under the ends of the isolation valves (item 8 and 9) to catch water drippings.
4. CLOSE isolation valve item 9, then crack open the valve slightly. Leave top isolation valve item 8 open.
5. Slowly open the boiler drain valve (item 10) and fresh water supply to fill boiler with water. The boiler and piping will fill quickly because of the low water content.
6. When water begins to flow from bottom isolation valve (item 9), close the valve.
7. Continue filling until water flows from top isolation valve (item 8), then close the valve.
8. When pressure on the pressure/temperature gauge (item 4) reaches at least 45 PSIG, but no higher than 55 PSIG, CLOSE the boiler drain valve (item 10).
9. Hold at test pressure for 10 minutes.

▲WARNING Do not leave boiler unattended. A cold water fill could expand and cause excessive pressure, resulting in severe personal injury, death or substantial property damage.

10. Make sure constant gauge pressure has been maintained throughout test. Check for leaks. Repair if found.

▲WARNING Leaks must be repaired at once. Failure to do so can damage boiler, resulting in substantial property damage.

▲WARNING Do not use petroleum-based cleaning or sealing compounds in boiler system. Gaskets and seals in the system may be damaged. This can result in substantial property damage.

Drain and remove fittings

1. Disconnect fill water hose from water source.
 2. Drain boiler through drain valve (item 10).
- ▲WARNING** Use caution when releasing pressure from the boiler. Rapid water flow could cause injury.
3. Remove hose after draining.
 4. Remove nipples and valves unless they will remain for use in the system piping.
 5. Remove plug and install relief valve as specified in the following WARNING.

▲WARNING Remove plug from relief valve street elbow. Install the relief valve in the ¾" street. See page 40 to install relief valve discharge piping. Failure to install the boiler relief valve could result in severe personal injury, death or substantial property damage.

3 Prepare boiler continued

Figure 6 Install pipe fittings for relief valve and pressure/temperature gauge — **DO NOT mount relief valve until AFTER hydrostatic testing** (see legend below)

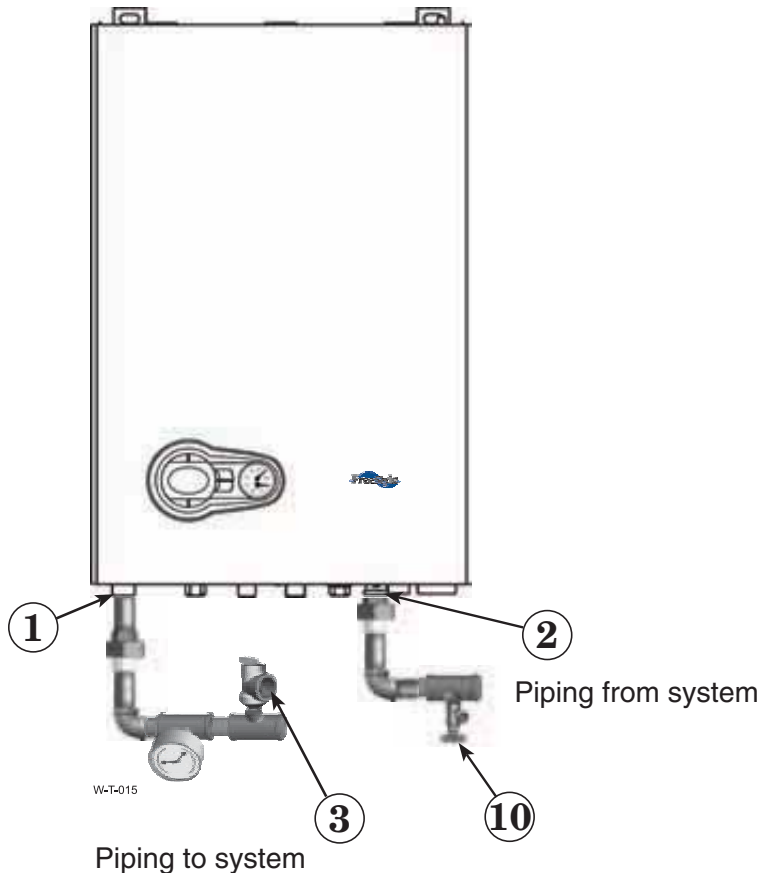
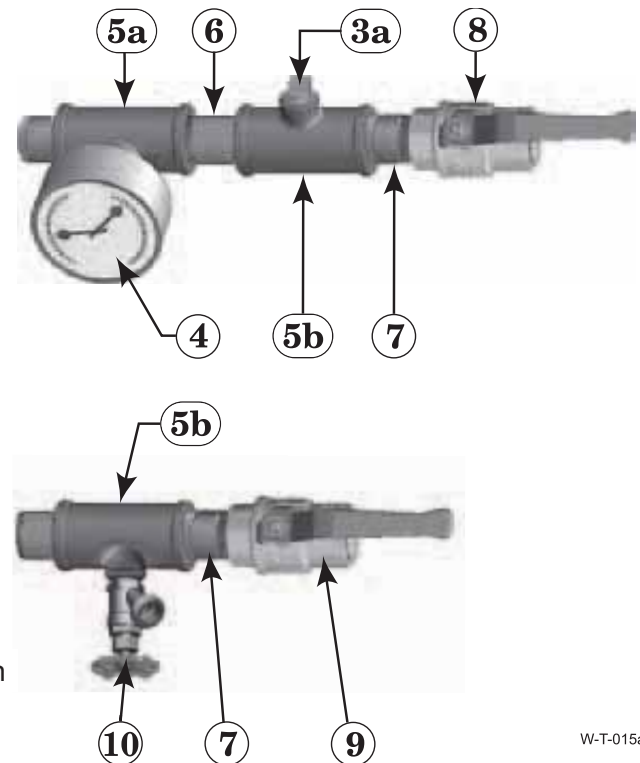


Figure 7 Install piping components required for hydrostatic test (see legend below)



1. Boiler supply (outlet) connection, (male, $\frac{3}{4}$ " NPT on FS-80/120, 1" NPT on FS-155).
2. Boiler return (inlet) connection, (male, $\frac{3}{4}$ " NPT on FS-80/120, 1" NPT on FS-155).
3. Boiler relief valve, shipped loose with boiler — **DO NOT mount relief valve until AFTER hydrostatic testing.**
- 3a. **TEMPORARILY ONLY** — Insert a $\frac{3}{4}$ " NPT plug in the relief valve tapping of the reducing tee. **This MUST BE REMOVED after the test and the relief valve mounted here.**
4. Pressure/temperature gauge, (field supplied) by installer
- 5a. Reducing tee, NPT, $\frac{3}{4}$ " x $\frac{3}{4}$ " x $\frac{1}{4}$ " on FS-80/120, NPT, 1" x 1" x $\frac{1}{4}$ " on FS-155.
- 5b. Tee, NPT, $\frac{3}{4}$ " x $\frac{3}{4}$ " x $\frac{3}{4}$ " on FS-80/120, NPT, 1" x 1" x $\frac{3}{4}$ " on FS-155.
6. Nipple, NPT $\frac{3}{4}$ " x close on FS-80/120, NPT, 1" x close on FS-155, (field supplied) by installer
7. Nipple, NPT $\frac{3}{4}$ " x close on FS-80/120, 1" x close on FS-155, (field supplied) by installer
8. Isolation valve on supply connection, (field supplied) by installer ($\frac{3}{4}$ " NPT on FS-80/120, 1" NPT on FS-155).
9. Isolation valve on return connection, (field supplied) by installer ($\frac{3}{4}$ " NPT on FS-80/120, 1" NPT on FS-155).
10. $\frac{3}{4}$ " NPT boiler drain valve, (field supplied) by installer — after hydrostatic testing, move drain valve to lowest point on the return piping if not already there.

4 Converting boiler to propane

Prepare boiler for propane (if required)

FreeStyle® 80/120/155

Propane operation

⚠ WARNING ALL FreeStyle® boilers must be converted for propane operation.

Converting an existing natural gas-fired boiler for propane — For a boiler already installed, you must turn off gas supply, turn off power and allow boiler to cool before proceeding. You must also completely test the boiler after conversion to verify performance and start up the boiler following instructions beginning on page 70 of this manual.

Verify Conversion kit—See Figure 8.

LP gas venturi will have a black label and will be clearly labeled “LPG”.

Natural gas venturi will have a white label and will be clearly labeled “NG”.

Failure to comply could result in severe personal injury, death or substantial property damage.

⚠ WARNING

This conversion kit shall be installed by a qualified service agency in accordance with the manufacturer’s instructions and all applicable codes and requirements of the authority having jurisdiction. If the information in these instructions is not followed exactly, a fire, an explosion or production of carbon monoxide may result causing property damage, personal injury or loss of life. The qualified service agency is responsible for the proper installation of this kit. The installation is not proper and complete until the operation of the converted appliance is checked as specified in the manufacturer’s instructions supplied with the kit.

Figure 8 Natural and Liquefied Petroleum (Propane) gas conversion kits

Boiler Model	Kit Part Number
FS-80 NG	640-000-022WT
FS-80 LP	640-000-024WT
FS-120 NG	640-000-023WT
FS-120 LP	640-000-025WT
FS-155 NG	640-000-082WT
FS-155 LP	640-000-083WT

Natural to LP Conversion Kit Part Numbers

FS-80 LP P/N 640-000-024WT NG to Propane Gas Conversion Kit contents:		
36602430	Venturi - 10.6 GPL	1
35105080	Gasket Nitrile Rubber 167 x 63.5X3.53 NBR	1
3541F210	Label Gas Conversion	1
3541G190	Label FS-80 Rating Plate Conversion LP	1
550-142-854	Instructions Conversion Nat to LP Gas	1

FS-120 LP P/N 640-000-025WT NG to Propane Gas Conversion Kit contents:		
36602450	Venturi - 12.6 GPL	1
35105080	Gasket Nitrile Rubber 167 x 63.5X3.53 NBR	1
3541F210	Label Gas Conversion	1
3541G200	Label FS-120 Rating Plate Conversion LP	1
550-142-854	Instructions Conversion Nat to LP Gas	1

FS-155 LP P/N 640-000-083WT NG to Propane Gas Conversion Kit contents:		
36602880	Venturi - 16.6 GPL	1
35105080	Gasket Nitrile Rubber 167 x 63.5X3.53 NBR	1
3541F210	Label Gas Conversion	1
3541G200	Label FS-155 Rating Plate Conversion LP	1
550-142-854	Instructions Conversion Nat to LP Gas	1

LP to Natural Conversion Kit Part Numbers

FS-80 NG P/N 640-000-022WT LP to Natural Gas Conversion Kit contents:		
36602390	Venturi - Natural Gas 10.6 m	1
35105080	Gasket Nitrile Rubber 167 x 63.5X3.53 NBR	1
3541F210	Label Gas Conversion	1
3541G190	Label FS-80 Rating Plate Conversion NG	1
550-142-855	Instructions Conversion LP to Natural Gas	1

FS-120 NG P/N 640-000-023WT LP to Natural Gas Conversion Kit contents:		
36602400	Venturi - Natural Gas 12.6 m	1
35105080	Gasket Nitrile Rubber 167 x 63.5X3.53 NBR	1
3541F210	Label Gas Conversion	1
3541G480	Label FS-120 Rating Plate Conversion NG	1
550-142-855	Instructions Conversion LP to Natural Gas	1

FS-155 NG P/N 640-000-082WT LP to Natural Gas Conversion Kit contents:		
36602870	Venturi - Natural Gas 16.6m	1
35105080	Gasket Nitrile Rubber 167 x 63.5X3.53 NBR	1
3541F210	Label Gas Conversion	1
3541G480	Label FS-155 Rating Plate Conversion NG	1
550-142-855	Instructions Conversion LP to Natural Gas	1

⚠ WARNING

- Follow all instructions in proper order.
- Do not tamper with venturi. DO NOT change or modify venturi in any way.
- Do not leave an uninstalled venturi in the building.
- Caution the gas supply shall be shut off prior to disconnecting the electrical power, before proceeding with the conversion.

⚠ CAUTION

Label all wires prior to disconnection when servicing controls. Wiring errors can cause improper and dangerous operation.

4 Converting boiler to propane continued

Pipe sizing for propane gas

- Contact propane gas supplier to size piping, tank and install a 100% lockup gas pressure regulator, or to verify size and condition of existing piping and equipment.

Natural and Propane supply pressure requirements

Adjust propane supply regulator provided by gas supplier for 13" w.c. maximum pressure.

For natural gas or propane, the pressure required at gas valve inlet pressure port (verify minimum gas pressure when all gas appliances are in operation):

- Maximum: 13" w.c. with no flow (lockup) or with boiler on.
 - Minimum gas pressure, with gas flowing (verify during boiler startup, while boiler is at high fire)
 - FreeStyle® 80: 3.5" w.c.;
 - FreeStyle® 120: 3.5" w.c.;
 - FreeStyle® 155: 3.5" w.c.
 - Nominal gas pressure: 11.0" w.c.
- Install 100% lockup gas pressure regulator in supply line if inlet pressure can exceed 13" w.c. at any time. Adjust lockup regulator for 13" w.c. maximum.
 - After connecting propane gas line to boiler, and BEFORE operating, check gas pressure. If gas pressure is not in the range above, close manual gas valve and contact gas supplier to correct the problem before attempting to start or operate the boiler.

Installing venturi —

WARNING If boiler is already installed — You must turn off electrical supply to the boiler and close the external manual gas shut-off valve to isolate the boiler during conversion. Allow the boiler to cool if it has been operating.

Following conversion of an installed boiler, follow all instructions in this manual to start up the boiler and verify operation of the boiler and all system components.

Verify proper venturi for gas type

The venturi(s) provided with the kit(s) are permanently marked on labels to indicate gas type “NG” Natural gas or “LPG” for Liquefied petroleum (propane) gas and supplier part number. See Figure 8, page 12 for kit contents.

Figure 9 Natural gas venturi label information



Figure 10 Liquefied Petroleum (propane) gas venturi label information



Front panel removal

- Remove two (2) **A** screws on the bottom flange of front panel, out and lift up to remove the front panel.
- Remove the one (1) screw holding control module in place Figure 12, rotate the control module.

Figure 11 Removing front panel

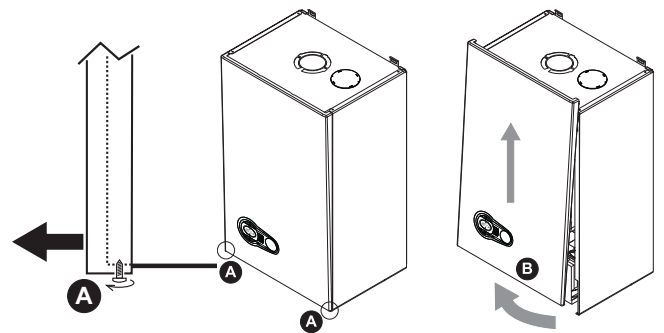
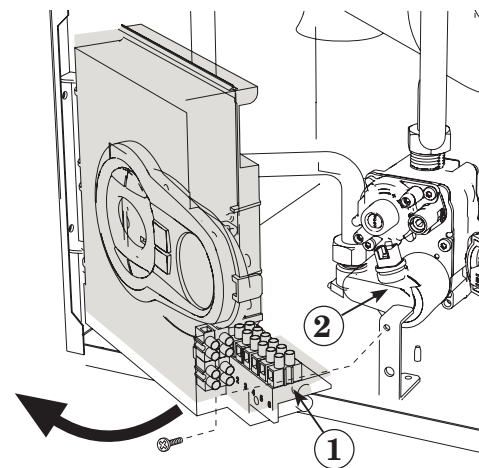


Figure 12 Moving control module for access to gas valve

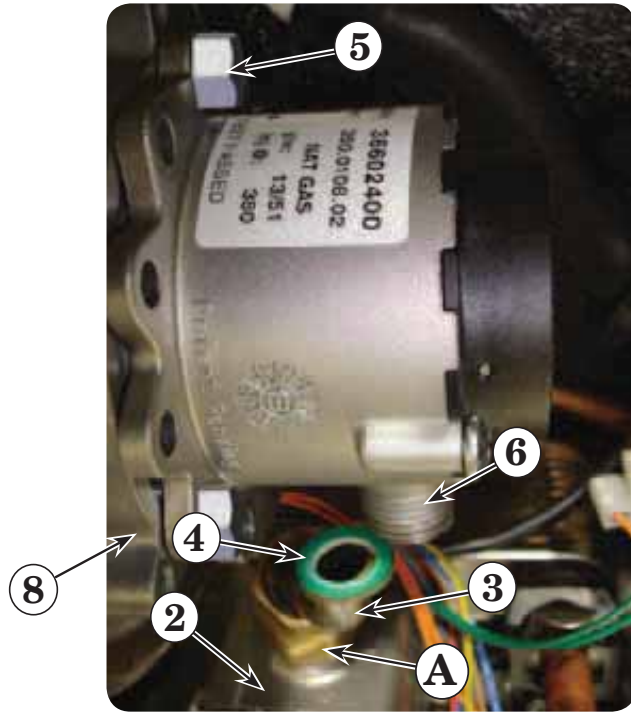


LEGEND for Figure 12	
1	Control module
2	Gas valve

4 Converting boiler to propane continued

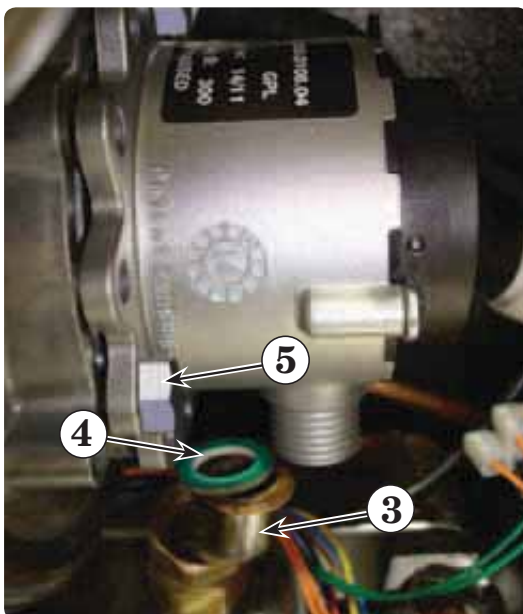
- Loosen the bottom swivel nut of gas pipe and unscrew the top swivel nut "A" Figure 13, Item 3 from the gas valve venturi Figure 13, Item 6.

Figure 13 Gas valve venturi replaced for propane conversion (Control panel removed for clarity)



- Remove three (3) Hex head screws holding the venturi, Item 5 in place, remove venturi, replace with new propane venturi from kit. Verify the venturi label information matches the boiler size (80, 120 or 155).

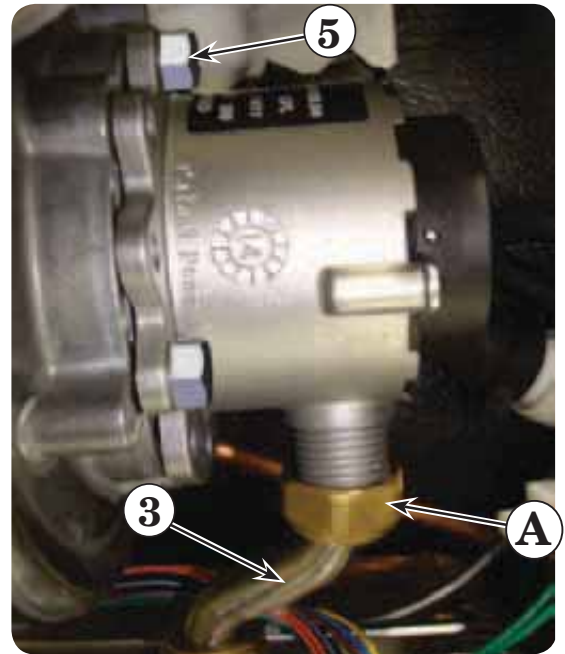
Figure 14 LP venturi installed to blower



LEGEND for Figures 12, 13, 14 and 15

1	Control panel (page 13)	5	Hex head screws
2	Gas valve (page 13)	6	Gas valve venturi
3	Gas pipe	7	"O" Ring
4	Washer	8	Blower

Figure 15 Gas pipe re-assembled to LP venturi fitting



- (Propane venturi has black label), ensure Item 7, venturi "O" ring is in place (see Figure 16), re-insert three (3) Hex head screws to hold new venturi, tighten to hold securely in place.
- Reassemble gas pipe and new washer to the venturi fitting, re-connect nut "A" and gas pipe "Item 3" to venturi and check the seal of the connection.

Figure 16 Insure "O" ring is in place.



4 Converting boiler to propane continued

▲ DANGER Inspect the gas pipe fitting connections on the gas valve and new venturi (Item 3, Figure 15) check the seal of the connections. Failure to comply will cause a gas leak, resulting in severe personal injury or death.

▲ WARNING Do not check for gas leaks with an open flame — use bubble test. Failure to use bubble test or check for gas leaks can cause severe personal injury, death or substantial property damage.

6. Reinstall control module, reinstall screw to hold control module securely in place.
7. Reinstall jacket door, and secure with two (2) screws.

Setup for normal operating sequence of ignition system.

8. Adjust parameter for the type of gas:
 - a. Put the boiler in standby mode.
 - b. Press the DHW buttons details 1 and 2 - Figure 74, page 60 for 10 seconds: the display shows “b01” flashing.
 - c. Press the DHW buttons Figure 74, page 60 details 1 and 2 - to set parameter 00 (for use with natural gas) or 01 (for use with LP).
 - d. Press the Heating (+) button to scroll to Parameter “b04”.
 - e. Press DHW (-) to reduce the Maximum Fan Speed, see Figure 119, page 93:
 - From 155 to 145 for the FS-80 boiler.
 - From 200 to 185 for the FS-120 boiler.
 - From 205 to 200 for the FS-155 boiler.
 - f. Press the (+) button to scroll to Parameter “b05”.
 - g. Repeat Step “e” above according to your boiler size.
 - h. Press the Heating (+) button to scroll to Parameter “b06”.
 - i. Press DHW (+) to increase the Minimum Fan Speed, see Figure 119, page 93:
 - From 39 to 40 for the FS-155 boiler.
 - No change needed for the FS-80/120 boilers.
 - j. Press the DHW buttons details 1 and 2 - Figure 74, page 60 for 10 seconds.
 - k. The boiler will return to standby mode.
9. Check the working pressure.
10. Test ignition system safety shutoff, see page 74.

Gas Rate (Natural Gas) After 10 minutes from cold		
Combi Boiler model	Maximum rate	Minimum rate
	ft ³ /h	ft ³ /h
FS-80	78.4	7.8
FS-120	117.6	11.8
FS-155	151.9	15.3

11. The required input rating of the converted boiler doesn't change.
12. In USA Input rates are derated 4% for each 1000 ft. above sea level, beyond 2000 ft. in accordance with National Fuel Gas Code, ANSI Z223.1/NFPA 54.
13. Using a combustion analyzer insert probe into the flue test point, check that the CO₂ content in the exhaust, with the boiler operating at max. and min. firing rate, matches that given in the technical data Figure 98, page 73 or Figure 101, page 74, for the corresponding type of gas.

▲ WARNING **DO NOT ATTEMPT TO MEASURE VALVE OUTLET PRESSURE.** The valve could be damaged by manometer fluid contamination. Failure to comply could result in severe personal injury, death or substantial property damage.

14. Restore electrical power, turn on gas by opening manual gas valve, check for leaks.

Perform Boiler Manual start-up

▲ WARNING Follow all instructions in Boiler Manual to start-up the boiler after converting for propane. Because the boiler has been changed, **you must verify correct operation, including checking combustion with test instruments both at high fire and low fire as described in the Boiler Manual, pages 69, 70 & 71.** Check the correct ignition sequence of the boiler after the conversion, as in page 82.

Failure to comply could result in severe personal injury, death or substantial property damage.

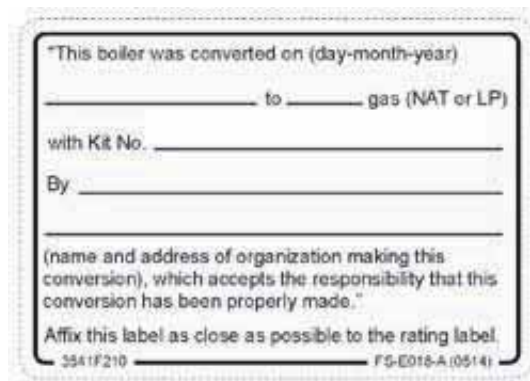
Replace boiler jacket front door

▲ WARNING Replace boiler jacket front door after servicing. The boiler front door must be securely fastened to the boiler frame to prevent boiler from drawing air from inside the boiler room. This is particularly important if the boiler is located in the same room as other appliances. Failure to keep the door securely fastened could result in severe personal injury or death.

Apply installer conversion label

1. Converting to propane firing: After installation is complete, attach the propane conversion label (from kit) next to the boiler rating label.
2. Contractor/installer is responsible for completing the information required on label (provided in kit) and attaching installer conversion label next to the boiler rating label.

Figure 17 Installer conversion label



▲ WARNING **The jacket door must be in place during operation.** DO NOT operate the boiler with the jacket door removed except for inspection and testing as directed in this manual.

5 Gas piping — sizing gas lines

NOTICE Boiler gas connection is ½” NPT. Size gas lines large enough to provide gas to all connected appliances.

Natural Gas:

Pipe sizing for natural gas

1. Size gas piping from meter outlet to entrance of boiler in accordance with Figure 18 and Figure 19.
2. Use total input of all connected appliances. Divide total input in Btuh by 1,000 to obtain cubic feet per hour of natural gas.
 - a. Pipe lengths in Figure 18 are equivalent length of straight pipe. Convert pipe fittings to equivalent lengths using data from Figure 19.
 - b. Figure 18 is only for natural gas with specific gravity 0.60, with a pressure drop through the gas piping as listed in the table.

Natural gas supply pressure

1. Pressure required at gas valve inlet pressure port:
 - a. Maximum: 13” (330 mm) w.c. with no flow (lockup).
 - b. Minimum gas pressure, with gas flowing (verify during boiler startup, while boiler is at high fire):
 - FreeStyle® 80: 3.5” w.c.
 - FreeStyle® 120: 3.5” w.c.
 - FreeStyle® 155: 3.5” w.c.
 Nominal gas pressure: 7.0” w.c.
2. Install 100% lockup gas pressure regulator in supply line if inlet pressure can exceed 13” w.c. at any time. Adjust lockup regulator for 13” w.c. maximum.

Propane Gas:

WARNING You must follow the instructions, beginning on page 12, to operate the boiler on propane. Failure to comply could result in severe personal injury, death or substantial property damage.

Pipe sizing for propane gas

1. Contact gas supplier to size pipes, tanks and 100% lockup gas pressure regulator.

Propane supply pressure

1. Adjust propane supply regulator provided by gas supplier for 13” w.c. maximum pressure.
2. Pressure required at gas valve inlet pressure port:
 - a. Maximum: 13” w.c. with no flow (lockup).
 - b. Minimum gas pressure, with gas flowing (verify during boiler startup, while boiler is at high fire):
 - FreeStyle® 80: 3.5” w.c.
 - FreeStyle® 120: 3.5” w.c.
 - FreeStyle® 155: 3.5” w.c.
 Nominal gas pressure: 11.0” w.c.

Figure 18 Pipe capacity for 0.60 specific gravity natural gas; pipe length is in equivalent feet

Gas pipe total length, feet	Capacity						
	Cubic feet per hour, natural gas, 0.60 specific gravity Gas pressure 13” w.c. or less Pressure drop 0.3 inches w.c.						
	½”	¾”	1”	1¼”	1½”	2”	2½”
10	132	278	520	1050	1600	3050	4800
20	92	190	350	730	1100	2100	3300
30	73	152	285	590	890	1650	2700
40	NA	130	245	500	760	1450	2300
50	NA	115	215	440	670	1270	2000
75	NA	105	175	360	545	1020	1650
100	NA	96	150	305	460	870	1400
150	NA	90	120	250	380	710	1130

Figure 19 Equivalent lengths of straight pipe for typical gas line fittings

Pipe size (inches)	Equivalent length, feet			
	90° Elbow		Tee	
	short radius	long radius	line flow	branch flow
½	3.6	2.2	1.7	4.2
¾	4.4	2.3	2.4	5.3
1	5.2	2.7	3.2	6.6
1¼	6.6	3.2	4.6	8.7
1½	7.4	3.4	5.6	9.9
2	8.5	3.6	7.7	12.0
2½	9.3	4.0	9.3	13.0

6 Venting/air piping — general

▲ DANGER

Do not install the FreeStyle® boiler into a common vent with any other appliance. This will cause flue gas spillage or appliance malfunction, resulting in possible severe personal injury, death or substantial property damage.

▲ WARNING

Existing common vent systems may be too large for the appliances remaining connected after the existing boiler is removed.

▲ WARNING

Failure to follow all instructions can result in flue gas spillage and carbon monoxide emissions, causing severe personal injury or death.

5. Test for spillage at draft hood relief opening after 5 minutes of main burner operation. Use the flame of a match or candle, or smoke from a cigarette, cigar, or pipe.
6. After it has been determined that each appliance remaining connected to the common venting system properly vents when tested as outlined herein, return doors, windows, exhaust fans, fireplace dampers, and any other gas-burning appliance to their previous conditions of use.

Any improper operation of common venting system should be corrected so the installation conforms with the National Fuel Gas Code, ANSI Z223.1 — latest edition. Correct by re-sizing to approach the minimum size as determined using the appropriate tables in Part 13 of that code.

When removing a boiler from an existing common vent system

The FreeStyle® boiler cannot be common vented with any other appliance. When an existing boiler is replaced with a FreeStyle® boiler, the FreeStyle® boiler CANNOT use the existing common vent. The FreeStyle® boiler requires its own vent and air piping, as specified in this manual. This may cause a problem for the appliances that remain on the old common vent, because the vent may be too large. The following test is intended to check for proper operation of the appliances remaining on the old common vent system.

Vent system verification

Perform the test sequence below for **each** appliance remaining on the original common vent system. Operate each appliance individually, with other appliances turned off. This procedure will test whether the common vent system can properly vent each appliance.

Existing vent test procedure

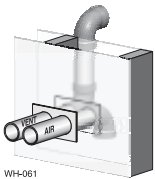

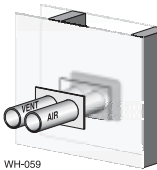
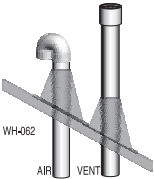
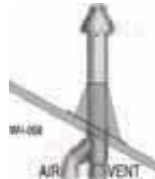
(The following is intended to test whether the appliances remaining on an existing vent system will operate satisfactorily.)

1. Seal any unused openings in the common venting system.
2. Visually inspect the venting system for proper size and horizontal pitch and determine there is no blockage or restriction, leakage, corrosion or other deficiencies which could cause an unsafe condition.
3. Test vent system — Insofar as is practical, close all building doors and windows and all doors between the space in which the appliances remaining connected to the common venting system are located and other spaces of the building. Turn on clothes dryers and any appliance not connected to the common venting system. Turn on any exhaust fans, such as range hoods and bathroom exhausts, so they will operate at maximum speed. Do not operate a summer exhaust fan. Close fireplace dampers.
4. Place in operation the appliance being inspected. Follow the operating instructions. Adjust thermostat so appliance will operate continuously.

6 Venting/air piping — general continued

Figure 20 Venting and air piping — DIRECT VENT ONLY — OPTIONS and PIPING LIMITS

NOTICE The table below lists the acceptable vent/air pipe terminations described in this manual. Follow all instructions provided to install the vent/air system. **NOT SHOWN** below, but also approved, are the polypropylene piping and terminations listed in Figure 21, page 19. For these applications, use **ONLY** the manufacturers' parts listed and follow all instructions provided by the pipe manufacturer.

FreeStyle® Model	Maximum vent and air pipe length = 100 feet for all applications (Minimum length for all applications is 2 feet)								USE SWEEP ELBOWS ONLY	
	(All applications include allowance for the termination fittings plus one elbow in air piping and one elbow in vent piping)									
	See Figure 21, page 19 for material specifications See Figure 153, page 113 for part/kit numbers									
	Vent and air pipe sizes: Maximum vent lengths apply for either 2" or 3" vent and air pipe. If using 2" pipe (FS-80/120 only), provide 3"x 2" reducers at boiler connections and at vent/air cap or at concentric terminations. Boilers will derate as vent/air pipe length increases — *see rating data on Figure 167, page 127 for derate amounts.									
	SIDEWALL termination					VERTICAL termination				
	Separate pipes [Note 1]		PVC or PP Concentric [Note 1]		3" PVC vent/air cap [Note 1]		Separate pipes [Note 1]		PVC or PP Concentric [Note 1]	
										
	See page 23		See page 25		See page 24 & 26		See page 27		See page 29	
	Size, inches	Materials Fig. 21, page 19	Size, inches	Materials Fig. 21, page 19	Size, inches	Materials Fig. 21, page 19	Size, inches	Materials Fig. 21, page 19	Size, inches	Materials Fig. 21, page 19
	FS-80	2	PVC/PVC-DWV CPVC, PP, SS	2	PVC/PVC-DWV CPVC, PP, SS	2	PVC/PVC-DWV CPVC, PP, SS	2	PVC/PVC-DWV CPVC, PP, SS	2
3		PVC/PVC-DWV CPVC, PP, SS	3	PVC/PVC-DWV CPVC, PP, SS	3	PVC/PVC-DWV CPVC, PP, SS	3	PVC/PVC-DWV CPVC, PP, SS	3	PVC/PVC-DWV CPVC, PP, SS
FS-120	2	PVC/PVC-DWV CPVC, PP, SS	2	PVC/PVC-DWV CPVC, PP, SS	2	PVC/PVC-DWV CPVC, PP, SS	2	PVC/PVC-DWV CPVC, PP, SS	2	PVC/PVC-DWV CPVC, PP, SS
	3	PVC/PVC-DWV CPVC, PP, SS	3	PVC/PVC-DWV CPVC, PP, SS	3	PVC/PVC-DWV CPVC, PP, SS	3	PVC/PVC-DWV CPVC, PP, SS	3	PVC/PVC-DWV CPVC, PP, SS
FS-155	3	PVC/PVC-DWV CPVC, PP, SS	3	PVC/PVC-DWV CPVC, PP, SS	3	PVC/PVC-DWV CPVC, PP, SS	3	PVC/PVC-DWV CPVC, PP, SS	3	PVC/PVC-DWV CPVC, PP, SS






WARNING All elbows in vent and air piping must be sweep elbows ONLY. DO NOT use short-radius elbows.

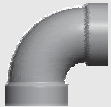


Equivalent feet for elbows (USE SWEEP ELBOWS ONLY) — deduct from max equivalent length of piping (does not apply to termination fittings)
• 7 feet per for each additional 90° sweep elbow or 45° elbow — If piping contains more than 1 elbow in air or vent piping, other than termination fittings

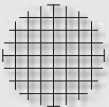

Note 1: Material abbreviations: PP = polypropylene, SS = AL29-4C stainless steel
If using stainless pipe, provide adapters for terminations, if required
IPEX 3" PVC concentric vent kits can be used with standard PVC pipe, fittings and cement (ANSI/ASTM D1785) except if ULC S636 compliance is required. For ULC S636 compliance, all pipe, fittings and cement must be IPEX System 636. If using IPEX kits, use only IPEX product code 196006 for 3" venting.

6 Venting/air piping — general continued

Figure 21 Vent and air piping materials — Use only the materials listed below, ensuring that all materials meet local codes (see Figure 153, page 113 for part/kit numbers)

Item	Material	Standards for installations in: United States
Plastic piping materials		Vent or air piping
Vent or air pipe & fittings	PVC schedule 40	ANSI/ASTM D1785
	PVC-DWV schedule 40	ANSI/ASTM D2665
	CPVC schedule 40	ANSI/ASTM F441
PVC & ABS pipe cement & primer	PVC	ANSI/ASTM D2564/F656
	CPVC	ANSI/ASTM F493
Polypropylene vent pipe, fittings, terminations and cement	Simpson-Duravent — Obtain all materials from M&G Simpson-Duravent Centrotherm Eco Systems InnoFlue® Single-wall — Obtain all materials from Centrotherm	See manufacturer's literature for detailed information MUST USE LOCKING COLLAR ON EVERY JOINT
AL29-4C stainless steel piping materials		
Vent pipe AL29-4C stainless steel	Heat Fab, Inc. — Saf-T-Vent® Z-Flex, Inc. — Z-Vent II Dura-Vent — FasNSeal® Metal-Fab, Inc. — CORR/GUARD	Certified for direct vent appliance venting
Stainless steel bird screens, 2" or 3" (purchase separately) — see Figure 153, page 113 for part numbers		
 WARNING	DO NOT mix piping from different pipe manufacturers unless using adapters specifically designed for the purpose by the manufacturer.	 WARNING ADAPTERS FreeStyle® Boiler comes with a 3", 3-in-1 adapter as standard. This adapter allows the installation of 3" PVC schedule 40, CPVC schedule 40, PVC-DWV schedule 40, AL29-4C stainless steel and Polypropylene (from Simpson-Duravent only) piping without the need for extra adapters. It may require an adapter at terminations. If your venting system uses Centrotherm Eco systems InnoFlue single wall material, then an approved adapter is required. If using 2" piping (FS-80/120 only), where approved for the application, provide adapters for a 3" pipe material (mentioned above) connections and at the terminations, if required.
 WARNING	Every joint on polypropylene vent piping must include a locking collar.	
 WARNING	DO NOT use cellular core PVC (ASTM F891), cellular core CPVC, or Radel® (polyphenolsulfone) in venting systems.	
 WARNING	DO NOT cover non-metallic vent pipe and fittings with thermal insulation.	

 	 WARNING USE SWEEP ELBOWS FOR ALL VENT AND AIR PIPING — DO NOT use short radius elbows for vent or air piping. Boiler performance could be affected.
---	---

	 WARNING ALL vent and air pipes require a BIRD SCREEN at each termination . Most kits do not include the bird screens. Purchase bird screens separately from Williamson-Thermoflo or vent kit supplier if not included. [Note — bird screening is integral to the 3" PVC W- T sidewall vent cap, available for purchase from Williamson-Thermoflo. No additional screening is required.]
---	--

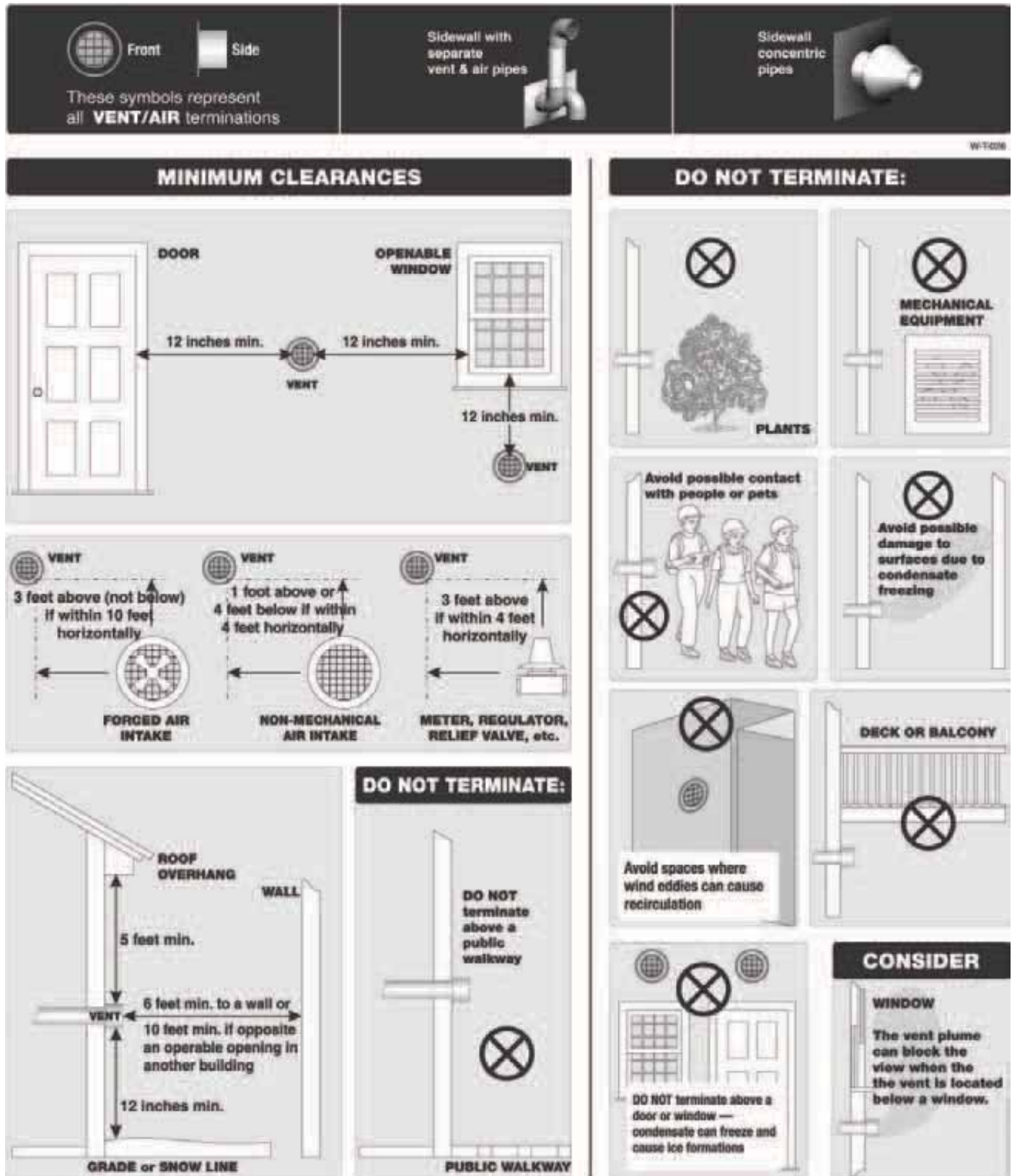
7 Commonwealth of Massachusetts installations

Commonwealth of Massachusetts — When the boiler is installed within the Commonwealth of Massachusetts, the boiler must be installed by a licensed plumber or gas fitter. Read and comply with the instructions below.

- (a) For all sidewall horizontally-vented gas-fueled equipment installed in every dwelling, building or structure used in whole or in part for residential purposes, including those owned or operated by the Commonwealth and where the side wall exhaust vent termination is less than seven (7) feet above finished grade in the area of the venting, including but not limited to decks and porches, the following requirements shall be satisfied:
1. **INSTALLATION OF CARBON MONOXIDE DETECTORS.** At the time of installation of the side wall horizontally vented gas fueled equipment, the installing plumber or gas fitter shall observe that a hard wired carbon monoxide detector with an alarm and battery back-up is installed on the floor level where the gas equipment is to be installed. In addition, the installing plumber or gas fitter shall observe that a battery operated or hard wired carbon monoxide detector with an alarm is installed on each additional level of the dwelling, building or structure served by the side wall horizontal vented gas fueled equipment. It shall be the responsibility of the property owner to secure the services of qualified licensed professionals for the installation of hard wired carbon monoxide detectors
 - a. In the event that the side wall horizontally vented gas fueled equipment is installed in a crawl space or an attic, the hard wired carbon monoxide detector with alarm and battery back-up may be installed on the next adjacent floor level.
 - b. In the event that the requirements of this subdivision can not be met at the time of completion of installation, the owner shall have a period of thirty (30) days to comply with the above requirements; provided, however, that during said thirty (30) day period, a battery operated carbon monoxide detector with an alarm shall be installed.
 2. **APPROVED CARBON MONOXIDE DETECTORS.** Each carbon monoxide detector as required in accordance with the above provisions shall comply with NFPA 720 and be ANSI/UL 2034 listed and IAS certified.
 3. **SIGNAGE.** A metal or plastic identification plate shall be permanently mounted to the exterior of the building at a minimum height of eight (8) feet above grade directly in line with the exhaust vent terminal for the horizontally vented gas fueled heating appliance or equipment. The sign shall read, in print size no less than one-half (1/2) inch in size, "GAS VENT DIRECTLY BELOW. KEEP CLEAR OF ALL OBSTRUCTIONS."
 4. **INSPECTION.** The state or local gas inspector of the side wall horizontally vented gas fueled equipment shall not approve the installation unless, upon inspection, the inspector observes carbon monoxide detectors and signage installed in accordance with the provisions of 248 CMR 5.08(2)(a) 1 through 4.
- (b) **EXEMPTIONS:** The following equipment is exempt from 248 CMR 5.08(2)(a)1 through 4:
1. The equipment listed in Chapter 10 entitled "Equipment Not Required To Be Vented" in the most current edition of NFPA 54 as adopted by the Board; and
 2. Product Approved side wall horizontally vented gas fueled equipment installed in a room or structure separate from the dwelling, building or structure used in whole or in part for residential purposes.
- (c) **MANUFACTURER REQUIREMENTS — GAS EQUIPMENT VENTING SYSTEM PROVIDED.** When the manufacturer of Product Approved side wall horizontally vented gas equipment provides a venting system design or venting system components with the equipment, the instructions provided by the manufacturer for installation of the equipment and the venting system shall include:
1. Detailed instructions for the installation of the venting system design or the venting system components; and
 2. A complete parts list for the venting system design or venting system.
- (d) **MANUFACTURER REQUIREMENTS — GAS EQUIPMENT VENTING SYSTEM NOT PROVIDED.** When the manufacturer of a Product Approved side wall horizontally vented gas fueled equipment does not provide the parts for venting the flue gases, but identifies "special venting systems", the following requirements shall be satisfied by the manufacturer:
1. The referenced "special venting system" instructions shall be included with the appliance or equipment installation instructions; and
 2. The "special venting systems" shall be Product Approved by the Board, and the instructions for that system shall include a parts list and detailed installation instructions.
- (e) A copy of all installation instructions for all Product Approved side wall horizontally vented gas fueled equipment, all venting instructions, all parts lists for venting instructions, and/or all venting design instructions shall remain with the appliance or equipment at the completion of the installation.

8 Vent termination requirements

Figure 22 The vent termination must be located to meet all requirements below (also applies to vertical vent terminations). The minimum distance from adjacent public walkways, adjacent buildings, openable windows and building in the National Fuel Gas Code, ANSI Z223.1/NFPA 54 and/or the Natural Gas and Propane Installation Code, CAN/CSA B149.1.



9 Boiler room air openings

Figure 23 Combustion and ventilation air openings for FreeStyle® Direct Vent installations. Provisions for combustion and ventilation air to be in accordance with the section “Air for Combustion and Ventilation,” of the National Fuel Gas Code, ANSI Z223.1/NFPA 54, or applicable provisions of the local building codes.

<p>WARNING The FreeStyle® boiler CANNOT be in the same space with other appliances if clearances around the FreeStyle® are less than the recommended service clearances shown in Figure 2, page 7.</p>		
Air openings	FreeStyle® boiler WITH other appliances in room	FreeStyle® boiler WITHOUT other appliances in room
<p>The required air opening sizes below are FREE AREA, after reduction for louver obstruction. Note the exception below for large spaces.</p>		
	<p>TWO openings, each at least: 1 square inch per 1,000 Btuh of all other appliances in the room (Unless specified otherwise by appliance manufacturer)</p>	
	<p>TWO openings, each at least: 1 square inch per 4,000 Btuh of all other appliances in the room — OR — ONE opening **, each at least: 1 square inch per 3,000 Btuh of all other appliances in the room (Unless specified otherwise by appliance manufacturer)</p>	<p>NO openings are required if the boiler installation provides at least the recommended service clearances shown in Figure 2, page 7.</p>
<p style="text-align: center;">Outside or ventilated attic</p>	<p>TWO openings, each at least: 1 square inch per 4,000 Btuh of all other appliances in the room — OR — ONE opening **, each at least: 1 square inch per 3,000 Btuh of all other appliances in the room (Unless specified otherwise by appliance manufacturer)</p>	<p>Provide openings ONLY as shown in Figure 2, page 7.</p> <p>Each opening must have a free area no less than 1 square inch per 1,000 Btuh input of the boiler.</p>
	<p>TWO openings, each at least: 1 square inch per 2,000 Btuh of all other appliances in the room — OR — ONE opening **, each at least: 1 square inch per 3,000 Btuh of all other appliances in the room (Unless specified otherwise by appliance manufacturer)</p>	
<p>** NOTICE: Requirements for using the SINGLE air opening option.</p>	<p>A single combustion air opening can be used for cases b, c or d above (FreeStyle® with other appliances in room only), sized as listed, provided that:</p> <ul style="list-style-type: none"> • The single opening must communicate directly to the outdoors or to a space that communicates directly with outdoors (NOT to an interior space). • The top of the opening must be within 12 inches of the ceiling. • The free area of the opening must be at least equal to the sum of the areas of all equipment vent connectors in the space. 	
<p>SPECIAL EXCEPTION FOR LARGE SPACES (FreeStyle® WITH other appliances in room only):</p>	<p>NO combustion air openings are needed if the boiler (and other appliances) are installed in a space with a volume NO LESS than 50 cubic feet per 1,000 Btuh of all appliances in the space. That is, total the input of all appliances in MBH (1,000's of Btuh), then multiply this total times 50. The building MUST NOT be of tight construction.</p> <p>Example: For a total input of 500 MBH (500,000 Btuh), the minimum volume would be 50 x 500 = 25,000 cubic feet.</p>	

10 DIRECT VENT — Sidewall with separate pipes

Allowable vent/air pipe materials & lengths

▲WARNING Use only the vent materials and kits listed in Figure 21, page 19. Provide pipe adapters if specified.

1. Locate the termination such that the total air piping and vent piping from the boiler to the termination will not exceed the maximum length given in Figure 20, page 18.

Polypropylene For polypropylene applications, comply with any additional requirements in the vent system manufacturer's instructions. (Do Not use 3" PVC transition pieces at the boiler vent and air connections). Install a locking collar at every joint.

AL29-4C S.S. For AL29-4C vent pipe applications, comply with any additional requirements in the vent system manufacturer's instructions. Provide a AL29-4C starter piece from the AL29-4C manufacturer for the transition piece at the boiler vent connection. The air piping must be PVC or CPVC. Provide a 3" PVC transition piece at the boiler air connection if using 2" air piping.

Determine termination location

1. Wall penetration thickness between 2" to 24".
2. The air and vent terminations must be installed as shown in Figure 24, page 23 and Figure 26, page 24.
3. The terminations must comply with clearances and limitations shown in Figure 22, page 21.
4. Locate the terminations so they are not likely to be damaged by foreign objects, such as stones or balls, or subject to buildup of leaves or sediment.
5. Vent and air locations can be on different building walls. Example: Vent/exhaust can be on North building wall and air intake can be on South building wall. (Different pressure zone).

▲WARNING Do not exceed the maximum lengths of the outside vent piping shown in Figure 24. Excessive length exposed to the outside could cause freezing of condensate in the vent pipe, resulting in potential boiler shutdown. In extremely cold climates, install an insulated chase around the vent piping, particularly if using longer lengths. The chase must allow for inspection of the vent pipe, and insulation must be protected from water.

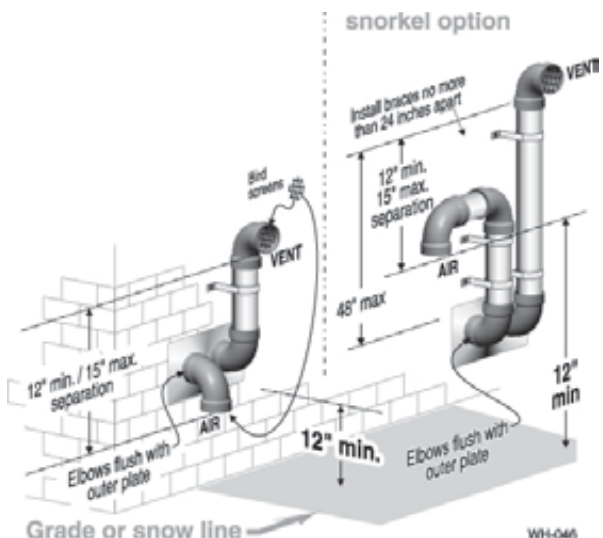
Multiple vent/air terminations

1. When terminating multiple boilers, terminate each vent/air connection as described in this manual.
2. Place wall penetrations to obtain minimum clearances shown in Figure 24 for U. S. installations.
3. The air inlet of a FreeStyle® boiler is part of a direct vent connection. It is not classified as a forced air intake with regard to spacing from adjacent boiler vents.

Prepare wall penetrations

1. Air pipe penetration:
 - a. Cut a hole for the air pipe. Size the air pipe hole as close as desired to the air pipe outside diameter.
2. Vent pipe penetration:

Figure 24 INSTALLATION SEQUENCE — Separate pipes sidewall



- | | |
|----------------|--|
| Step 1 | Read and follow all instructions in this manual. DO NOT proceed with vent/air installation until you have read page 15 through page 20. Polypropylene AL29-4C S.S. See notices at left. |
| Step 2 | Install the boiler in a location that allows proper routing of all vent and air piping to the selected sidewall location. |
| Step 3 | Make sure the selected sidewall termination complies with Figure 22, page 21. (Multiple boiler sidewall plates must also comply with Figure 25, page 24.) |
| Step 4 | Use only the vent materials listed in Figure 21, page 19. Provide pipe adapters where required. Vent piping and air piping lengths must not exceed the values shown in Figure 20, page 18. |
| Step 5 | Prepare the sidewall penetrations and secure the sidewall plates as instructed in this section. See "Prepare wall penetrations" on page 23. Polypropylene AL29-4C S.S. See notices at left. |
| Step 6 | The air piping must terminate in a down-turned elbow as shown above. The vent piping must terminate in an elbow pointed outward or away from the air inlet as shown above. See illustration above. |
| Step 7 | Install vent and air piping between the boiler and the sidewall openings. Slope horizontal piping downward toward the boiler at least 1/4 inch per foot. See page 32 for general guidelines. Polypropylene AL29-4C S.S. See notices at left. |
| Step 8 | Install pipe supports every 5 feet on both the horizontal and vertical runs. Install a hanger support within 6 inches of any upturn in the piping, or per vent pipe manufacturer's instructions. Polypropylene AL29-4C S.S. See notices at left. |
| Step 9 | Attach the vent termination exterior piping: Use either of the configurations shown above, as needed to ensure clearance above grade or snow line. Keep vents/air intake area clear of accumulating snow. |
| Step 10 | The vent and air pipes may run up as high as 4 feet with no enclosure. The vent and air pipes must be secured with braces, and all clearances and lengths must be maintained. Space braces no further than 24 inches apart. |
| Step 11 | External venting greater than 4 feet requires an insulated enclosure around the vent and air pipes. The vent and air terminations must exit through the enclosure as shown in the illustration above, maintaining all required clearances. |



▲WARNING

USE SWEEP ELBOWS FOR ALL VENT AND AIR PIPING — DO NOT use short radius elbows for vent or air piping. Boiler performance could be affected.

10 DIRECT VENT — Sidewall with separate pipes continued

Polypropylene AL29-4C S.S. See notices on previous page.

- Cut a hole for the vent pipe. For either combustible or noncombustible construction, size the vent pipe hole at least 0.4" larger than the vent pipe diameter.
- Insert a galvanized metal thimble in the vent pipe hole as shown in Figure 26.
- Plate may be field fabricated from corrosion resistant material of sufficient strength. Plate must allow venting to maintain minimum clearance to combustibles.

WARNING Ensure that the plate material is strong enough to prevent the termination from being pushed inward if struck or pushed from the outside.

- Follow all local codes for isolation of vent pipe when passing through floors or walls.
- Seal exterior openings thoroughly with exterior caulk.

Termination and fittings

- Prepare the vent termination elbow and the air termination elbow by inserting bird screens. (See Figure 24, page 23.) Bird screens must be purchased separately. See the parts list at the end of this manual for part numbers.
- Secure the elbows so they will butt against the sidewall termination plate.
- When completed, the air termination coupling must be oriented at least 12 inches below the vent termination and at least 12 inches above grade or snow line as shown in Figure 24, page 23. Keep vents/air intake area clear of accumulating snow.
- You can orient the vent termination elbow either directly outward or 90 degrees away from the air inlet elbow as shown in Figure 24, page 23.
- Maintain the required dimensions of the finished termination piping as shown in Figure 24, page 23.
- For multiple boiler terminations, see Figure 25.
- Do not extend exposed vent pipe outside of building more than shown in this document. Condensate could freeze and block vent pipe.

NOTICE If extending the vent and air pipes out from the wall, install a coupling on each pipe. Mount the piping with the coupling flush with the outer plate.

NOTICE Wall penetration thickness between 2" to 24"

Figure 25 Multiple separate pipes sidewall terminations — maintain vertical spacing between vent and air fittings shown in Figure 24, page 23.

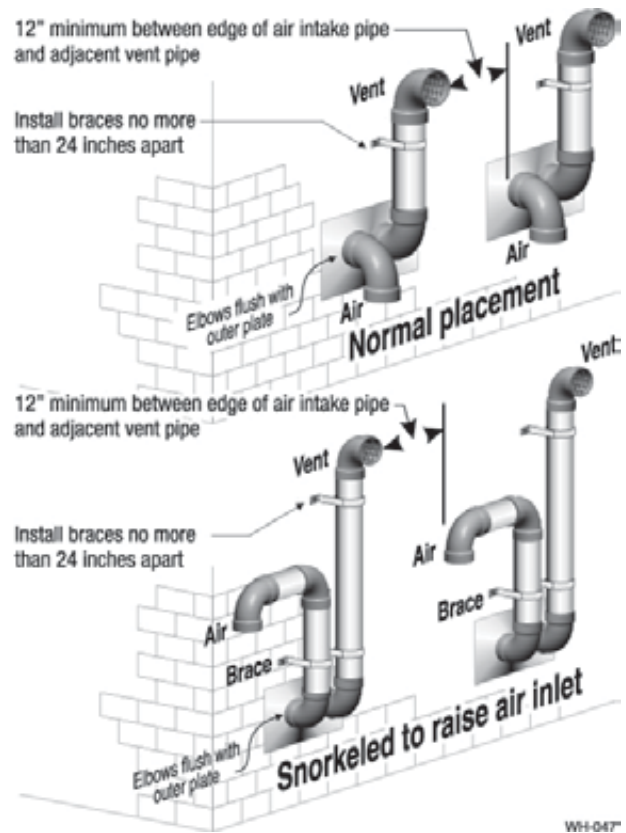
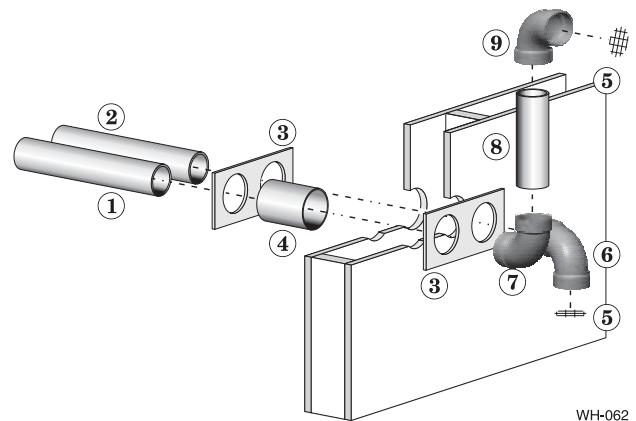


Figure 26 Sidewall termination assembly — using separate pipes



1 Vent piping	5 Bird screen, by installer
2 Air piping	6 Air inlet elbow
3 Sidewall termination plates: for 3" PVC or 3" AL29-4C or 2" PVC, (field supplied)	7 Elbow
4 Galvanized thimbles, by installer	8 Nipple
	9 Vent termination elbow

11 DIRECT VENT — Sidewall concentric

Allowable vent/air pipe materials & lengths

1. The concentric termination kit must be purchased separately.

⚠ WARNING Use only the vent materials and kits listed in Figure 21, page 19. Provide pipe adapters if specified.

2. Locate the termination such that the total air piping and vent piping from the boiler to the termination will not exceed the maximum length given in Figure 20, page 18.
3. This termination requires a 45-degree elbow that is not supplied with the termination kit. The maximum vent/air pipe lengths include allowance for this elbow.

Polypropylene For polypropylene applications, comply with any additional requirements in the vent system manufacturer's instructions. (Do Not use 3" PVC transition pieces at the boiler vent and air connections) and at the termination if using a 3" PVC concentric vent kit. Install a locking collar at every joint.

AL29-4C S.S. For AL29-4C vent pipe applications, comply with any additional requirements in the vent system manufacturer's instructions. Provide a AL29-4C starter piece from the AL29-4C manufacturer to the transition at the boiler vent connection. Air pipe must be PVC or CPVC. Provide a 3" PVC transition at the boiler air connection if using 2" air pipe. Provide transition pieces to PVC at the vent and air pipe termination connections.

NOTICE Wall penetration thickness between 2" to 24".

Determine termination location

1. The concentric termination kit must be installed as shown in Figure 29, page 26.
2. The termination must comply with clearances and limitations shown in Figure 22, page 21.
3. Locate the termination so it is not likely to be damaged by foreign objects, such as stones or balls, or subject to buildup of leaves or sediment.

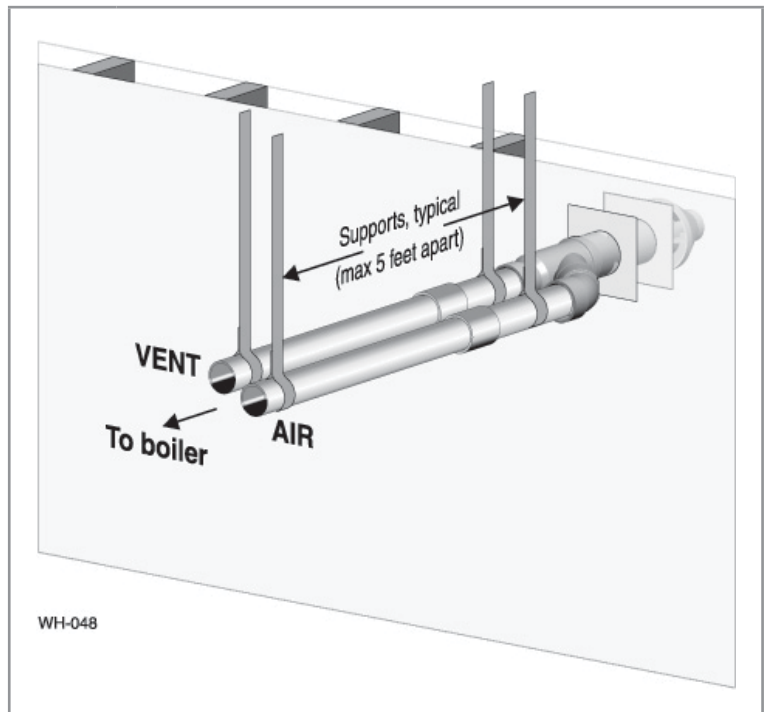
Multiple vent/air terminations

1. When terminating multiple boilers, install each concentric termination as described in this manual.

⚠ WARNING All vent pipes and air inlets must terminate at the same height to avoid possibility of severe personal injury, death or substantial property damage.

2. Place wall penetrations to obtain minimum clearance as shown in Figure 28, page 26 for U. S. installations.
3. The air inlet of a FreeStyle® boiler is part of a direct vent connection. It is not classified as a forced air intake with regard to spacing from adjacent boiler vents.

Figure 27 INSTALLATION SEQUENCE — Concentric horizontal



Step 1 Read and follow all instructions in this manual. **DO NOT proceed with vent/air installation until you have read page 15 through page 20.** **Polypropylene** **AL29-4C S.S.** See notices at left.

Step 2 Install the boiler in a location that allows proper routing of all vent and air piping to the selected sidewall location.

Step 3 Make sure the selected sidewall termination location complies with Figure 22, page 21. (Multiple boiler concentric terminations must also comply with Figure 28, page 26.)

Step 4 Use only the vent materials listed in Figure 21, page 19. Provide pipe adapters where required.

Step 5 Vent piping and air piping lengths must not exceed the values shown in Figure 20, page 18.

Step 6 The concentric termination must be assembled and installed before piping from the boiler to the termination.

Step 7 Prepare the sidewall penetration — assemble the concentric termination kit and secure the cover plates as instructed in this section. Provide the supports indicated and mount the termination assembly. See "Install termination — concentric pipes" on page 26. **Polypropylene** **AL29-4C S.S.** See notices at left.

Step 8 Install vent and air piping between the boiler and the concentric vent/air termination. Slope horizontal piping downward toward the boiler at least 1/4 inch per foot. See page 32 for general guidelines.

Step 9 Install pipe supports every 5 feet on both the horizontal and vertical runs. **Polypropylene** **AL29-4C S.S.** See notices at left.

Step 10 Install a hanger support within 6 inches of any upturn in the piping. **Polypropylene** **AL29-4C S.S.** See notices at left.



⚠ WARNING

USE SWEEP ELBOWS FOR ALL VENT AND AIR PIPING — DO NOT use short radius elbows for vent or air piping. Boiler performance could be affected.

11 DIRECT VENT — Sidewall concentric *(continued)*

Polypropylene AL29-4C S.S. See notices on previous page.

Install termination — concentric pipes

1. Assemble the vent termination as described for concentric terminations, on page 31.

WARNING If necessary, you can shorten the lengths of the inner and outer pipes for a shorter finished assembly. But you must ensure the pipes butt correctly at both ends. Failure to properly assemble the concentric termination can result in flue gas recirculation, causing possible severe personal injury or death.

2. Wall penetration:
 - a. Preferably, use a thimble with a 4½-inch hole. If not using a thimble, carefully use a hole saw to cut a hole not larger than 4¾ inches in diameter through the wall. The finished hole must provide a solid stop for the rain cap ribs, as shown in the inset to Figure 29.

NOTICE Wall penetration thickness between 2" to 24".

WARNING Ensure that the wall material is strong enough to prevent the rain cap from being pushed inward if struck or pushed from the outside.

3. Secure the termination in place so the rain cap will butt against the outside wall or outer thimble plate as shown in Figure 29.
4. Before beginning vent and air piping from the boiler to the concentric termination, mount and secure the concentric termination as shown in Figure 29.

WARNING The vent and air piping must be securely supported, and must not rest its weight on the boiler fittings. Failure to properly support the vent and air piping could result in vent piping damage, resulting in possible severe personal injury, death or substantial property damage.

The supports/bracing used must support the termination assembly to prevent slippage or movement. See instructions provided with concentric kit for details.

The clamps used on the outside of the termination pipe must not cut into the pipe or contain sharp edges that could cause a crack to form.

WARNING When inserting the partially-assembled termination kit through the wall penetration, wrap plastic or other protection over the end of the exposed assembly to prevent debris from entering the pipes. If the air passages become blocked, the boiler will not operate. Once the rain cap has been cemented to the assembly, there is no way to correct the problem. The assembly would have to be replaced if it were cut to be removed and cleaned. Altering the assembly in any way could result in severe personal injury or death due to toxic flue product emissions.

WARNING If using AL29-4C stainless vent pipe, use the vent pipe manufacturer's PVC adapter if connecting to a PVC concentric vent attachment.

5. After the assembly has been positioned in the opening and all supports have been attached, install a bird screen (purchased separately if not included with the kit) and rain cap as follows:
 - a. Place the bird screen on the end of the inner pipe as in Figure 35, page 31, or per concentric kit instructions for polypropylene kits.
 - b. Cement the rain cap in place as shown.

Figure 28 Termination location — concentric termination — multiple boilers — clearance from vent of one to air intake of the next

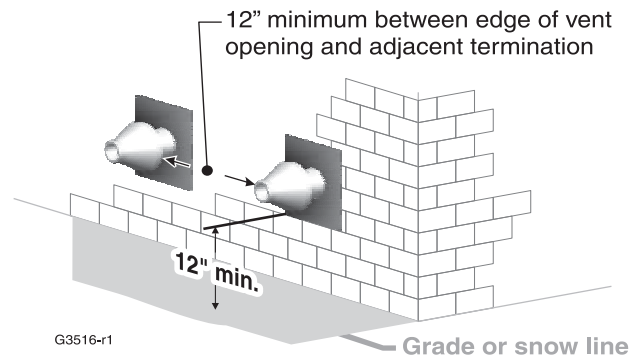
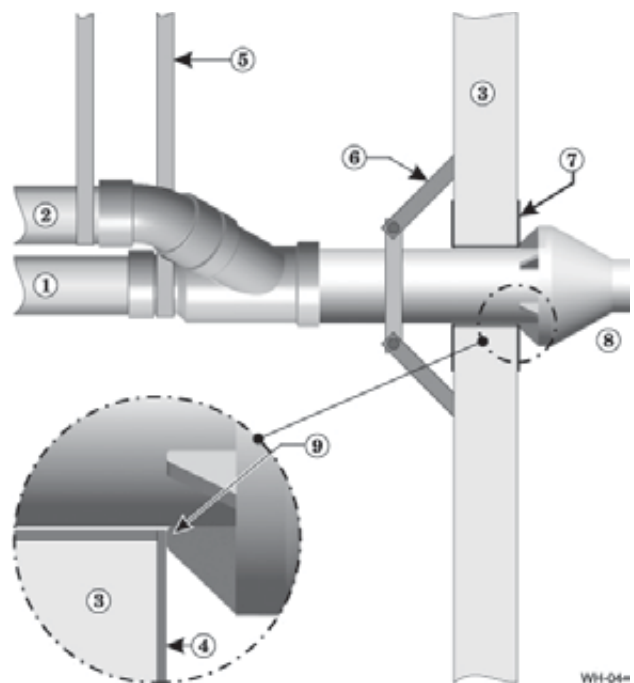


Figure 29 Installing and supporting the concentric sidewall vent assembly



LEGEND for Figure 29

- | | |
|---|---|
| 1 Vent pipe | 6 Wall brace, by installer, (or see vent pipe mfg's instructions) |
| 2 Air pipe | 7 Thimble, by installer |
| 3 Wall | 8 Rain cap |
| 4 Outer thimble plate | 9 Rain cap ribs must butt against outer thimble plate or wall opening |
| 5 Supports every 5 feet or per vent pipe mfg's instructions | |

12 DIRECT VENT — Vertical with separate pipes

Allowable vent/air pipe materials & lengths

▲WARNING Use only the vent materials and kits listed in Figure 21, page 19. Provide pipe adapters if specified.

1. Locate the terminations such that the total air piping and vent piping from the boiler to the termination will not exceed the maximum length given in Figure 19, page 19.

Polypropylene For polypropylene applications, comply with any additional requirements in the vent system manufacturer's instructions. (Do Not use 3" PVC transition pieces at the boiler vent and air connections). Install a locking collar at every joint.

AL29-4C S.S. For AL29-4C vent pipe applications, comply with any additional requirements in the vent system manufacturer's instructions. Provide a AL29-4C starter piece from the AL29-4C manufacturer to the transition piece at the boiler vent connection. The air piping must be PVC or CPVC. Provide a 3" PVC transition piece at the boiler air connection if using 2" air piping.

Determine termination location

1. The air and vent terminations must be installed as shown in Figure 30.
2. The terminations must comply with clearances and limitations shown in Figure 21, page 22.
3. Locate the terminations so they are not likely to be damaged by foreign objects, such as stones or balls, or subject to buildup of leaves or sediment.

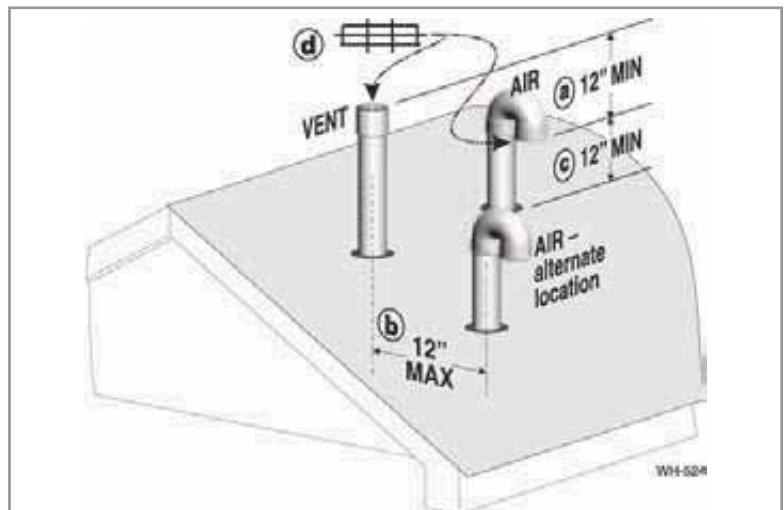
Multiple vent/air terminations

1. When terminating multiple boilers, terminate each vent/air connection as described in this manual.

▲WARNING Terminate all vent pipes at the same height and all air pipes at the same height to avoid possibility of severe personal injury, death or substantial property damage.

2. Place roof penetrations to obtain minimum clearance of 12 inches between edge of air intake elbow and adjacent vent pipe of another boiler for U. S. installations (see Figure 34, page 31).
3. The air inlet of a FreeStyle® boiler is part of a direct vent connection. It is not classified as a forced air intake with regard to spacing from adjacent boiler vents.

Figure 30 Separate pipes vertical termination



Terminate vent and air pipes such that:

- a. **AIR INTAKE** IS AT LEAST 12 inches below vent outlet
- b. **AIR INTAKE** IS NO FURTHER than 12 inches away center to center
- c. **AIR INTAKE** IS AT LEAST 12 inches above roof or snow line, keep vents/air intake area clear of accumulating snow.
- d. **Vent and air terminations are fitted with bird screens**

- Step 1** Read and follow all instructions in this manual. **DO NOT proceed with vent/air installation until you have read page 15 through page 20.** **Polypropylene** **AL29-4C S.S.** See notices at left.
- Step 2** Install the boiler in a location that allows proper routing of all vent and air piping to the selected sidewall location.
- Step 3** Make sure the selected vertical termination location complies with Figure 21, page 22. (Multiple boiler terminations must also comply with Figure 31, page 28.)
- Step 4** Use only the vent materials listed in Figure 21, page 19. Provide pipe adapters where required. Vent piping and air piping lengths must not exceed the values shown in Figure 20, page 18.
- Step 5** Prepare the vertical penetrations and secure penetration components as instructed in this section. See "Prepare roof penetrations" on page 28 and "Termination and fittings" on page 28.
- Step 6** The air piping must terminate in a 180-degree return bend or **down-turned elbow** as shown above. The vent piping must terminate in a **coupling pointed upward** as shown above.
- Step 7** Install vent and air piping between the boiler and the vertical terminations. Slope horizontal piping downward toward the boiler at least 1/4 inch per foot. Install pipe supports every 5 feet on both the horizontal and vertical runs. Install a hanger support within 6 inches of any upturn in the piping. See page 32 for general guidelines. Also comply with vent pipe manufacturer's instructions. **Polypropylene** **AL29-4C S.S.** See notices at left.
- Step 8** Insert the vent and air piping through the vertical penetrations and secure the termination fittings.
- Step 9** Maintain clearances shown above. Vent and air terminations must be fitted with a bird screen as shown.



▲WARNING **USE SWEEP ELBOWS FOR ALL VENT AND AIR PIPING** — DO NOT use short radius elbows for vent or air piping. Boiler performance could be affected.

12 DIRECT VENT — Vertical with separate pipes *(continued)*

Polypropylene AL29-4C S.S. See notices on previous page.

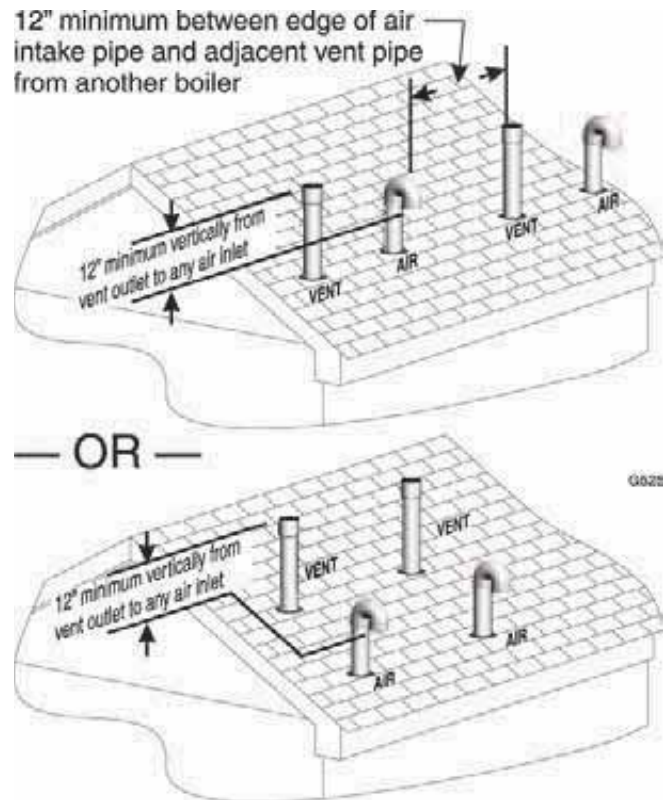
Prepare roof penetrations

1. Air pipe penetration:
 - a. Cut a hole for the air pipe. Size the air pipe hole as close as desired to the air pipe outside diameter.
2. Vent pipe penetration:
 - a. Cut a hole for the vent pipe. For either combustible or noncombustible construction, size the vent pipe hole at least 0.4" larger than the vent pipe diameter.
 - b. Insert a galvanized metal thimble in the vent pipe hole.
3. Space the air and vent holes no closer than the minimum spacings shown in Figure 23, page 24.
4. Follow all local codes and vent pipe manufacturer's instructions for isolation of vent pipe when passing through floors, ceilings and roofs.
5. Provide flashing and sealing boots sized for the vent pipe and air pipe. Follow all vent pipe manufacturer's instructions.

Termination and fittings

1. Prepare the vent termination elbow and the air termination elbow (Figure 30, page 27) by inserting bird screens. Bird screens must be purchased separately. See the parts list at the end of this manual for part numbers.
2. The air piping must terminate in a down-turned 180-degree return bend as shown in Figure 30, page 27. Locate the air inlet pipe no further than 12 inches from the center of the vent pipe. This placement avoids recirculation of flue products into the combustion air stream.
3. The vent piping must terminate in an up-turned coupling as shown in Figure 30, page 27. The top of the coupling must be at least 12 inches above the air intake. The air inlet pipe and vent pipe can be located in any desired position on the roof, but must always be no further than 12 inches apart (center to center) and with the vent termination at least 12 inches above the air intake.
4. Maintain the required dimensions of the finished termination piping as shown in Figure 30, page 27.
5. Do not extend exposed vent pipe outside of building more than shown in this document. Condensate could freeze and block vent pipe.

Figure 31 Terminations for multiple boilers



Also maintain maximum distances between the vent and air pipes for each boiler as shown in Figure 30, page 27.

13 DIRECT VENT — Vertical concentric

Allowable vent/air pipe materials & lengths

1. The concentric termination kit must be purchased separately.

▲WARNING Use only the vent materials and kits listed in Figure 21, page 19. Provide pipe adapters if specified.

2. Locate the termination such that the total air piping and vent piping from the boiler to the termination will not exceed the maximum length given in Figure 20, page 18.
3. This termination requires a 45-degree elbow that is not supplied with the termination kit. The maximum vent/air pipe lengths include allowance for this elbow.

Polypropylene For polypropylene applications, comply with any additional requirements in the vent system manufacturer's instructions. (Do Not use 3" PVC transition pieces at the boiler vent and air connections) and at the termination if using a 3" PVC concentric vent kit. Install a locking collar at every joint.

AL29-4C S.S. For AL29-4C vent pipe applications, comply with any additional requirements in the vent system manufacturer's instructions. Provide a AL29-4C starter piece from the AL29-4C manufacturer to the transition at the boiler vent connection. Air pipe must be PVC or CPVC. Provide a 3" PVC transition at the boiler air connection if using 2" air pipe. Provide transition pieces to PVC at the vent and air pipe termination connections.

Determine termination location

Locate the concentric vent/air termination using the following guidelines:

1. The concentric vent/air assembly must terminate as shown in Figure 34, page 30.
2. The termination must comply with the clearances and limitations shown in Figure 21, page 22.
3. Locate the termination so it is not likely to be damaged by foreign objects, such as stones or balls, or subject to buildup of leaves or sediment.

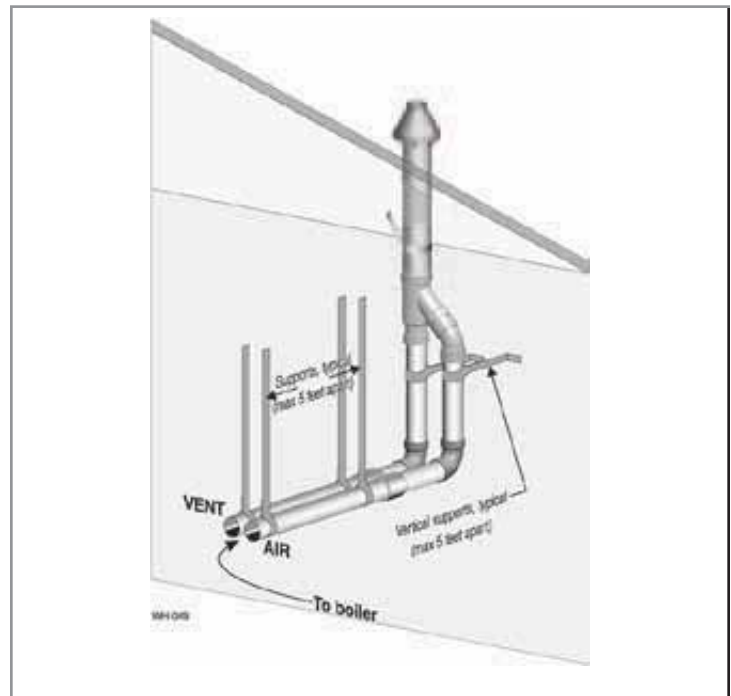
Multiple vent/air terminations

1. When terminating multiple boilers, install the concentric vent/air termination assemblies as described in this manual.

▲WARNING All vent outlets must terminate at the same height to avoid possibility of severe personal injury, death or substantial property damage.

2. Place roof penetrations to obtain minimum clearance of 12 inches between the edges of adjacent vent pipes of other boilers for U. S. installations (see Figure 33, page 30).
3. The air inlet of a FreeStyle® boiler is part of a direct vent connection. It is not classified as a forced air intake with regard to spacing from adjacent boiler vents.

Figure 32 INSTALLATION SEQUENCE — Concentric vertical



- Step 1** Read and follow all instructions in this manual. **DO NOT proceed with vent/air installation until you have read page 15 through page 20.** **Polypropylene** **AL29-4C S.S.** See notices at left.
- Step 2** Install the boiler in a location that allows proper routing of all vent and air piping to the selected sidewall location.
- Step 3** Make sure the selected vertical termination location complies with Figure 21, page 22. (Multiple boiler concentric terminations must also comply with Figure 33, page 30.)
- Step 4** Use only the vent materials listed in Figure 21, page 19. Provide pipe adapters where required.
- Step 5** Vent piping and air piping lengths must not exceed the values shown in Figure 20, page 18.
- Step 6** The concentric termination must be assembled and installed before piping from the boiler to the termination.
- Step 7** Prepare the vertical penetration(s) — assemble the concentric termination kit and secure the penetration components as instructed in this section. Provide the supports indicated and mount the termination assembly. See "Prepare roof penetrations" on page 30 and "Mount concentric termination" on page 30. **Polypropylene** **AL29-4C S.S.** See notices at left.
- Step 8** Install vent and air piping between the boiler and the concentric vent/air termination. Slope horizontal piping downward toward the boiler at least 1/4 inch per foot. See page 32 for general guidelines.
- Step 9** Install pipe supports every 5 feet on both the horizontal and vertical runs. **Polypropylene** **AL29-4C S.S.** See notices at left.
- Step 10** Install a hanger support within 6 inches of any upturn in the piping. **Polypropylene** **AL29-4C S.S.** See notices at left.



▲WARNING **USE SWEEP ELBOWS FOR ALL VENT AND AIR PIPING** — DO NOT use short radius elbows for vent or air piping. Boiler performance could be affected.

13 DIRECT VENT — Vertical concentric *(continued)*

Polypropylene AL29-4C S.S. See notices on previous page.

Prepare roof penetrations

1. Roof penetration hole:
 - a. Cut a clearance hole to clear the termination outside diameter as prescribed in the kit instructions.
 - b. Insert a galvanized metal thimble in the vent pipe hole.
2. Follow all local codes for isolation of vent pipe when passing through floors, ceilings and roofs.
3. Provide flashing and sealing boots sized for the concentric termination outside diameter.

Mount concentric termination

1. Assemble the vent termination as described for concentric terminations, on page 31.
2. Mount the termination as shown in Figure 34.
3. Support the concentric vent/air termination at the roof penetration as shown in Figure 34 or per concentric kit instructions.
 - The supports/bracing used must support the termination assembly to prevent vertical slippage or sideways movement.
 - The clamps used on the outside of the termination pipe must not cut into the pipe or contain sharp edges that could cause a crack to form.

WARNING The vent and air piping must be securely supported, and must not rest its weight on the boiler fittings. DO NOT drill or screw into either the vent pipe or air pipe. Failure to properly support the vent and air piping could result in vent piping damage, resulting in possible severe personal injury, death or substantial property damage.

WARNING When inserting the partially-assembled termination kit through the roof penetration, wrap plastic or other protection over the end of the exposed assembly to prevent debris from entering the pipes. If the air passages become blocked, the boiler will not operate. Once the rain cap has been cemented to the assembly, there is no way to correct the problem. The assembly would have to be replaced if it were cut to be removed and cleaned. Altering the assembly in any way could result in severe personal injury or death due to toxic flue product emissions.

WARNING If using AL29-4C stainless vent pipe, use the vent pipe manufacturer's PVC adapter if connecting to a PVC concentric vent attachment.

WARNING Do not connect any other appliance to the vent pipe or multiple boilers to a common vent pipe.

4. After the assembly has been positioned in the roof opening and all supports have been attached, install a bird screen (purchased separately if not included with the kit) and rain cap as follows:
 - a. Place the bird screen on the end of the inner pipe as in Figure 35, page 31, or per kit instructions for polypropylene kits.
 - b. Cement the rain cap in place.

Figure 33 Vertical termination — 3" PVC concentric — single or multiple boilers

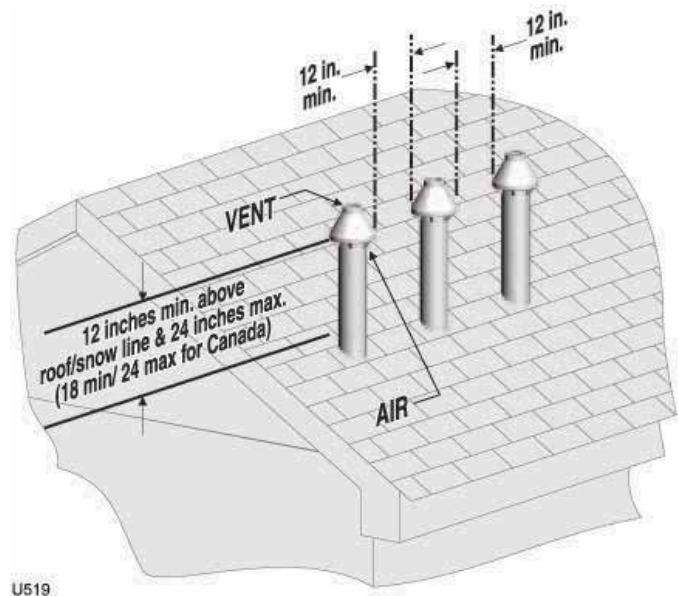
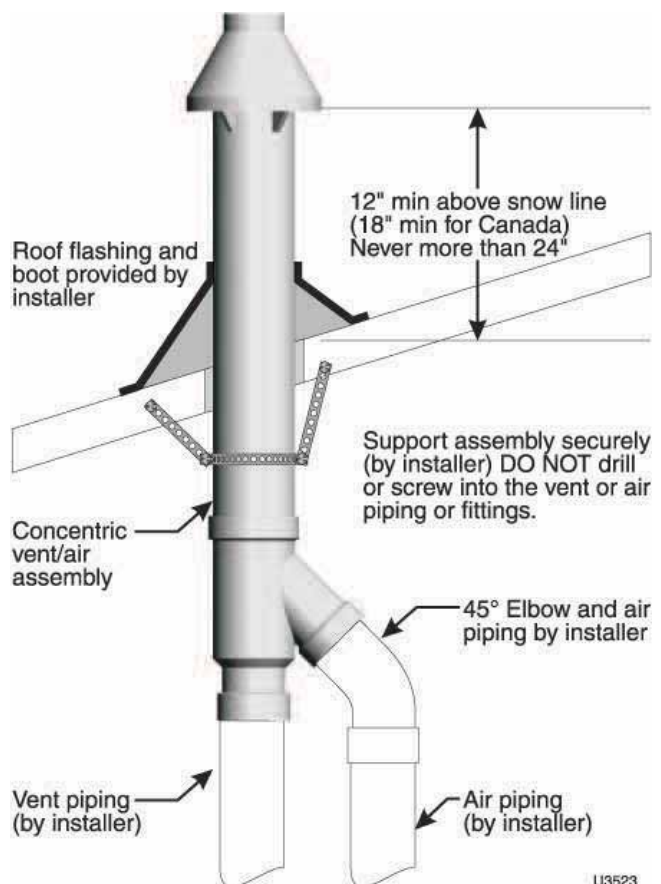
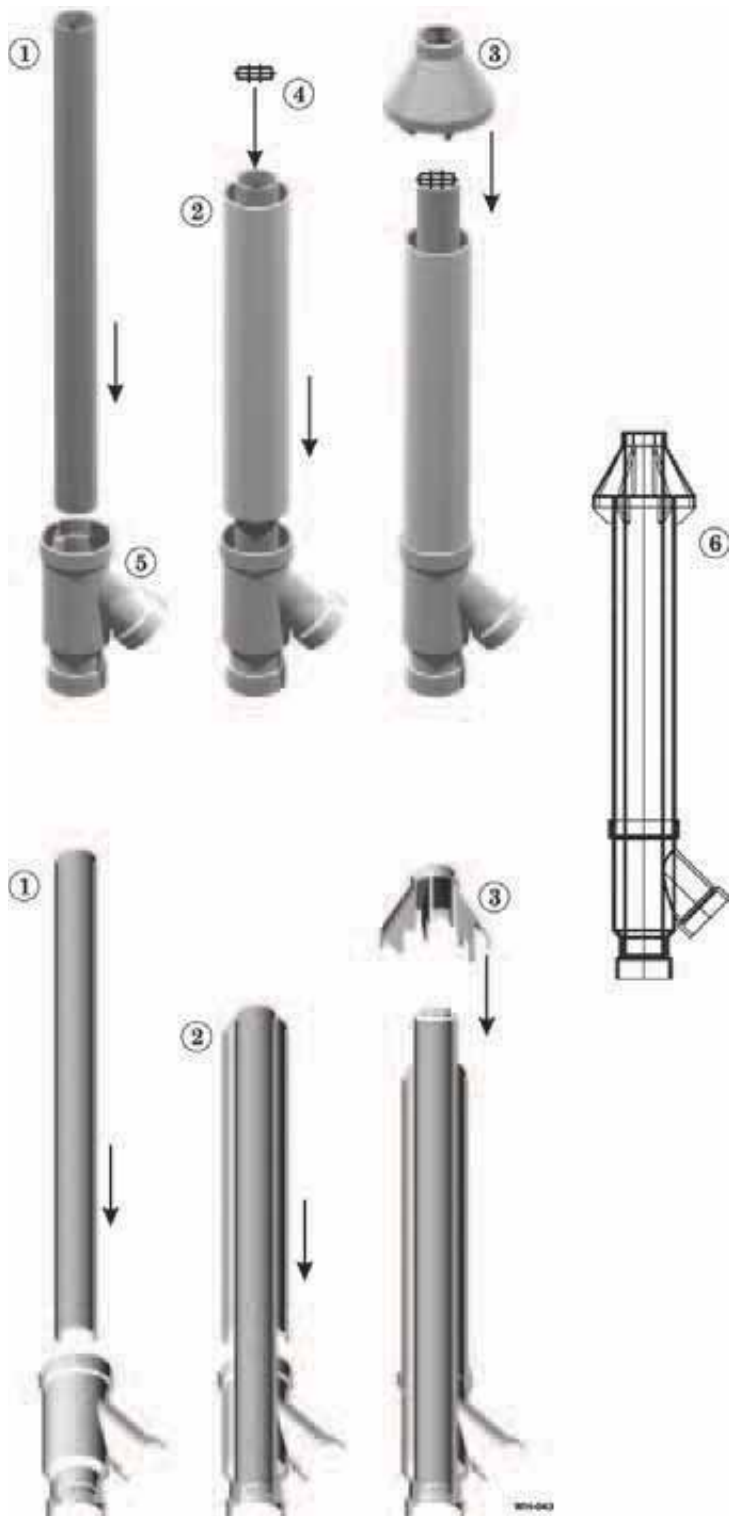


Figure 34 3" PVC concentric termination supports



14 Concentric termination, typical *(sidewall or vertical)*

Figure 35 PVC concentric termination assembly — DO NOT attach the rain cap until the termination has been inserted through the roof or wall and all supports have been installed. See LEGEND at right. See kit instructions for details of polypropylene kits.



LEGEND for Figure 35

- | | |
|---------------------------|-----------------------|
| 1 — Inner PVC pipe (vent) | 4 — Bird screen |
| 2 — Outer PVC pipe (air) | 5 — Y fitting |
| 3 — Rain cap | 6 — Finished assembly |

Assembling concentric termination

1. Follow all instructions provided with the concentric termination kit. The following are general guidelines for information only.
2. See Figure 35, for the typical assembly of a concentric termination assembly.
3. Prepare the bird screen, item 4 (purchase separately if not included with the kit). Cut the bird screen to size if required. If the bird screen must be trimmed, cut the bird screen to fit the outside diameter of the PVC inner pipe supplied with the termination kit.
4. Partially assemble the vent termination kit in the sequence shown in Figure 35, or per the concentric kit instructions.

WARNING DO NOT install the rain cap and bird screen until the assembly has been inserted through the roof (or sidewall) and all supports have been installed. Follow instructions to cover the end of the assembly with plastic before inserting through the roof penetration to prevent debris from blocking the air passages.

WARNING If necessary, you can shorten the lengths of the inner and outer pipes for a shorter finished assembly. But you must ensure the pipes butt correctly at both ends. Failure to properly assemble the concentric termination can result in flue gas recirculation, causing possible severe personal injury or death.

Polypropylene For polypropylene applications, comply with any additional requirements in the vent system manufacturer's instructions. (Do Not use 3" PVC transition pieces at the boiler vent and air connections) and at the termination if using a PVC concentric vent kit. Install a locking collar at every joint.

AL29-4C S.S. For AL29-4C vent pipe applications, comply with any additional requirements in the vent system manufacturer's instructions. Provide a AL29-4C starter piece from the AL29-4C manufacturer to the transition at the boiler vent connection. Air pipe must be PVC or CPVC. Provide a 3" PVC transition at the boiler air connection if using 2" air pipe. Provide transition pieces to PVC at the vent and air pipe termination connections.

15 Vent and air piping and boiler connections

Follow termination instructions

1. Read and follow all instructions for the termination type used before proceeding with this page. Follow all instructions provided by vent pipe manufacturer.

▲WARNING Use only materials from the manufacturers listed in Figure 21, page 19.

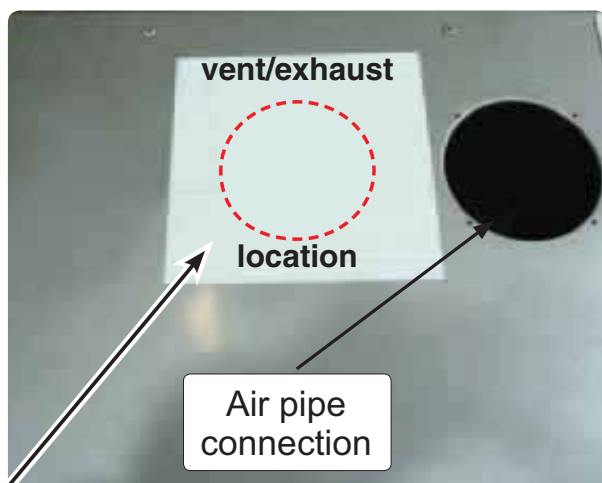
Installing vent and air piping

Polypropylene For polypropylene applications, comply with any additional requirements in the vent system manufacturer's instructions. (Do Not use 3" PVC transition pieces at the boiler vent and air connections).

AL29-4C S.S. For AL29-4C vent pipe applications, comply with any additional requirements in the vent system manufacturer's instructions.

1. Work from the boiler to vent or air termination. Do not exceed the lengths given in the previous pages for either the air or vent piping.
2. See Figure 36, for locations for attaching vent and air inlet adapters on to the boiler. Air inlet adapter connection is made on right side of centered flue adapter.
3. Remove vent/exhaust protective paper prior to mounting vent adapter.
4. Vent and air inlet adapters needed to be attached to top securely with four (4) 10-32 large Phillips head screws, see Figures 38, 39 and 40. Vent adapters (provided with boiler) are for polypropylene, PVC, and AL29-4C venting.
5. See Figure 38, center flue gasket and insert the extruded flue vent adapter into the center opening, secure with four (4) 10-32 Phillips head screws.

Figure 36 Boiler top opening (out of the carton)

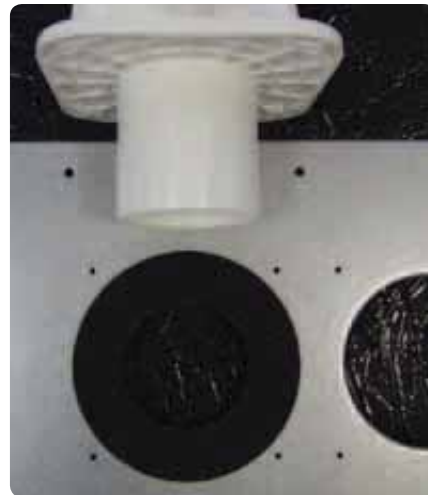


Remove protective paper.

Figure 37 Flue and vent adapter and gasket

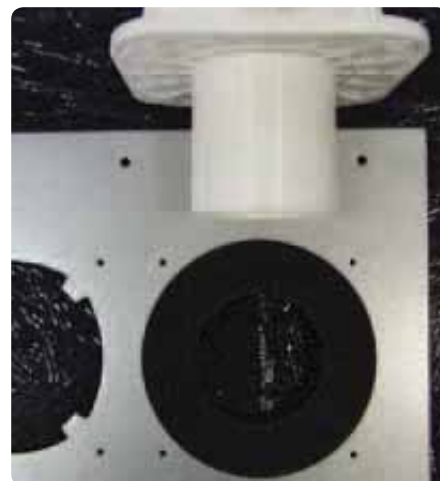


Figure 38 Vent flue adapter into top flue center opening



6. See Figure 40, right air inlet, center gasket and air inlet vent adapter over right opening, secure with four (4) 10-32 Phillips head screws.

Figure 39 Vent (air inlet) adapter inserted into top right opening



15 Vent and air piping and boiler connections *(continued)*

Figure 40 Vent (flue) and air adapters in place



Vent and Air adapters to be installed with test ports facing to front of boiler. Must be locked closed.

7. The adapter accepts 3" PVC, CPVC, Polypropylene and AL29-4C material. Use a 2" adapter (FS-80/120 only), if needed.

AL29-4C S.S. For AL29-4C vent pipe applications, comply with any additional requirements in the vent system manufacturer's instructions. Provide a AL29-4C starter piece from the AL29-4C manufacturer to the transition at the boiler vent connection.

8. Cut pipe to required lengths.
9. Dry assemble entire vent or air piping to ensure proper fit before assembling any joint.
10. Maintain minimum clearance of $\frac{3}{16}$ inch between vent pipe and any combustible wall or material.
11. Assembling PVC or CPVC: (**Polypropylene** **AL29-4C S.S.** — follow pipe manufacturer's instructions for preparation and assembly)
 - a. Deburr inside and outside of pipe ends.
 - b. Chamfer outside of each pipe end to ensure even cement distribution when joining.
 - c. Clean all pipe ends and fittings. Dry thoroughly.
 - d. For each joint:
 - Handle fittings and pipes carefully to prevent contamination of surfaces.
 - Apply primer liberally to both joint surfaces — pipe end and fitting socket.
 - While primer is still damp, lightly apply approved cement to both surfaces in a uniform coating.
 - Apply a second coat to both surfaces. Avoid using too much cement on sockets to prevent cement buildup inside.
 - With cement still wet, insert pipe into fitting, twisting $\frac{1}{4}$ turn. Make sure pipe is fully inserted.
 - Wipe excess cement from joint. Check joint to be sure a smooth bead of cement shows around the entire joint.
12. Seal wall or floor penetration openings following local code requirements.

▲WARNING **ADAPTERS** — Use adapters if using 2-inch pipe, (FS-80/120 only)

1. Clean and deburr inside and outside of both ends of air and vent pipes. Chamfer boiler end of vent pipe for ease of insertion.

▲WARNING The vent pipe end must be smooth and chamfered to prevent possible damage to sealing gasket in vent pipe adapter.

2. Inspect vent or air adapter (above) — verify no obstructions or foreign objects inside.
3. Loosen clamp screw (if used).
4. Measure $\frac{2}{4}$ -inches from end of pipe and make a mark with felt-tip pen.
5. Apply small amount of silicon grease to end of pipe to ease insertion.
6. Insert pipe into adapter.
7. Slide pipe down until the $\frac{2}{4}$ -inch mark is reached.

▲WARNING Do not apply excessive force or bend the adapter or flue/air pipe when inserting. The adapter or seal could be damaged. If any portion of the vent or air system is damaged, it must be replaced.

8. The seal is accomplished with the internal gasket.



▲WARNING **USE SWEEP ELBOWS FOR ALL VENT AND AIR PIPING** — DO NOT use short radius elbows for vent or air piping. Boiler performance could be affected.

15 Vent and air piping and boiler connections *(continued)*

Control selection for vent material

To insure proper boiler operation (Combi and Heating Only boilers) the boiler control is programmed default is for PVC venting material. You **MUST** program the boiler control for any other venting material that you installed other than PVC, in order to improve operational efficiency.

Refer to “**Quick Start Guide**” page 3, to first power up the boiler.

To access the configuration menu:

1. Press the DHW + and DHW – buttons together for 10 seconds.
2. At the end of the 10 seconds the display will show the message “b01”.
3. Press the heating buttons (+ or -) to scroll up the list of parameters in increasing or decreasing order to parameter “b22”.
4. Press the DHW buttons (+ or -) to view or modify the value of a parameter: the modification will be automatically saved.

For example: CPVC, Polypropylene, or AL29-4C stainless steel.

PVC solid core, Select: “1”

CPVC only, Select: “2”

Polypropylene and AL29-4C, Select: “0”

16 Install water piping

Domestic Water Piping – Combi Boiler

⚠ DANGER Hot Water Can Scald!

- Consumer Product Safety Commission and some states recommend domestic hot water temperature of 130°F or less.
- When installing an automatic mixing valve, selection and installation must comply with valve manufacturer’s recommendations and instructions.
- Water heated to a temperature suitable for clothes washing, dish washing and other sanitizing needs will scald and cause injury.
- Children, elderly, infirm or physically handicapped persons are more likely to be injured by hot water. Never leave them unattended in or near a bathtub, shower or sink. Never allow small children to use a hot water faucet or draw their own bath. If anyone using hot water in the building fits this description, or if state laws or local codes require certain water temperatures at hot water faucets, take special precautions:
 - Install automatic mixing valve set according to those standards.
 - Use lowest practical temperature setting.
 - Check water temperature immediately after first heating cycle and after any adjustment.

If the boiler piping system is connected to heating coils located in air handling units where there may be exposed to refrigerated air circulation then it must be equipped with flow control valves or other automatic means to prevent gravity circulation of the boiler water during the cooling cycle.

To pipe DHW:

1. Size piping no smaller than flat plate heat exchanges inlet and outlet.
2. Additional anti-scald devices may be installed at each hot water faucet, bath and shower outlet.
3. In hard water areas, soften cold domestic supply water to heaters to prevent scale build-up.
4. Refer to Figure 41, below for maximum and minimum domestic water pressure rating for our units, on the domestic pipes (Combi only).
5. Install (field supplied) domestic water pressure relief valve with a maximum pressure rating of 130 pounds.

Figure 41 Domestic water pressure rating

		Minimum	Maximum
DHW Pressure Rating	PSIG	4.5	130

Figure 42 DHW inlet has a filter screen



6. **Combi Boiler:** Domestic water inlet connection showing filter screen to protect paddle flow switch from sand and other debris.

NOTICE

Pipe in a “union” fitting below this adapter to service this filter screen.

- **Thermostatic Mixing Valve-** A mixing valve (for regulating domestic heating water) must be used to regulate the water temperature leaving the plate heat exchanger. NOTE: the valve must be set to supply a domestic water temperature of not more than 120 degrees F. It is the responsibility of the installer to set the valve and remove the dial.
- **DHW Filter-** Installation of a 100 micron or lower water filter at the entrance of the DHW connection to protect the DHW flow switch. Failure to install the DHW water filter from dirt and debris will cause it to malfunction.
- **Check Valve-** A check valve must be field provided and installed on the outlet of the mixing valve to prevent expansion devices downstream from back flowing when the water pressure drops during cold water draws. Failure to prevent the backflow will cause water to flow through the flow switch, activating it, when the cold water draw has ended and the water pressure increases.
- **Drain and Isolation Valves-** Install drain and isolation valves on the inlet and outlet of the DHW connections so that the DHW heat exchanger can be flushed and cleaned from possible build-up caused by dirty or hard water, which is a maintenance requirement.
- **Hard Water-** To prevent the formation of scale on the inside of the plate DHW heat exchanger and other components in the domestic hot water system, water with hardness higher than 50 ppm Calcium Carbonate must be treated with a “Water Softener” prior to entering the boiler. Plugging of the domestic system by scaling or accumulation of dirt is not the responsibility of Williamson-Thermoflo, and suitable steps must be taken to avoid it.
- **Cleaning-** refer to the installation manual maintenance section for the proper cleaning procedure for the plate DHW heat exchanger, and the required cleaning frequency.

16 Install water piping *(continued)*

WARNING Studies have indicated that dangerous bacteria can form in potable water distribution systems if certain minimum water temperatures are not maintained. Contact local health department for more information.

CAUTION This boiler is **NOT** intended for connection with a refrigeration system.

WARNING Use two wrenches when tightening water piping at boiler, using one of the wrenches to prevent the boiler interior piping from turning. Failure to support the boiler piping connections to prevent them from turning could cause damage to boiler components.

General piping information

Additional controls, if required

NOTICE The FreeStyle® control uses temperature sensors to provide both high limit protection and modulating temperature control. **The control's high limit function requires manual reset.** Some codes/jurisdictions may require additional external controls for high limit and/or low water cutoff protection.

Additional limit controls

Following standard industry practices, if installation is to comply with ASME requirements, an additional high temperature limit may be needed. Consult local requirements for other codes/standards to determine if needed.

1. Install a manual reset high temperature limit to prevent a temperature above 200°F in system supply piping between boiler and isolation valve. (Note that the control operating limit function shuts the boiler down at 195°F, or lower if set to a lower value.)

WARNING **Multi-temperature systems** — If the heating system includes circuits that require lower temperature water (radiant slab circuits, for example) as well as higher temperature circuits, it is recommended to protect low temperature circuits with limit controls that are wired to the control external limit circuit terminals.

WARNING **Low temperature systems** — If using temperature-limited materials (such as PEX tubing) in system piping, it is recommended to protect the system with limit controls that are wired to the controls external limit circuit.

2. See instructions beginning on page 50, for wiring information.

3. If using a manual reset limit control or wiring in the manual reset circuit, set FreeStyle® control boiler limit at least 20°F less than the external manual reset limit (i.e., set FreeStyle® control no higher than 180°F for a 200°F external limit, for example).

Backflow preventer

1. Use backflow preventer in the cold water supply piping if required by local codes.

System/zone pipe sizing

(Baseboard, convectors or cast iron radiators ONLY)

1. For residential space heating applications (other than radiant heating or unit heaters) ONLY, you can use the sizing suggestions in Figure 43.

Figure 43 Suggested pipe sizing for system headers and zone piping — RESIDENTIAL with baseboard, convectors or cast iron radiators ONLY (20°F temperature rise)

FreeStyle® Model	System header
FS-80/120/155	1" or larger
Recommendations are based on a 20°F temperature drop through the system.	
Suggested maximum load per zone	
Copper pipe and baseboard size	Maximum recommended feet of baseboard
¾"	67
1"	104
Size zone circulators to handle the required flow and head loss for each zone.	

System water piping methods

Primary/secondary piping to boiler

Using primary/secondary piping will provide the most efficient and reliable operation of the boiler and the heating system.

1. Use information beginning on page 37 to size pump for proper flow through the FreeStyle® boiler.
2. Reference suggested piping layouts on pages 38-43.

17 Primary/Secondary System Piping

System water piping methods

Near boiler piping

1. Connect boiler to system only as shown in Figure 45, page 38. The primary/secondary piping shown ensures the boiler loop will have sufficient flow.
2. Select a boiler loop temperature rise from Figure 47, page 39. The table indicates the flow and head loss characteristics at that temperature rise and suggests potential speed. Circulators of other brands not listed (Wilo, Armstrong, B&G) are acceptable if they meet the flow and head requirements of the design.

NOTICE Verify that the boiler loop piping matches closely with the listed criteria in the *NOTICE* below. If near boiler piping is different, calculate head loss separately using heat exchanger pressure drop information from Figure 47, page 39 and match to an appropriate pump speed.

NOTICE The pressure drops shown are for near boiler piping as illustrated in Figure 46, page 38 with 20 feet of straight piping. System circulators and zone circulators

3. Install a system circulator or zone circulators as shown in the piping diagrams in the Primary/Secondary System Piping section in this manual. These circulators must be supplied by the installer.

System or zone circulators flow rates

1. Size circulators based on the flow rate required to achieve the temperature drop required. You can closely estimate temperature rise (or drop) through a circuit by using the following formula, where TD is temperature rise (or drop), FLOW is flow rate (in gpm), and BTUH is the heat load for the circuit:

$$\text{FLOW} = \frac{\text{BTUH}}{\text{TD} \times 500}$$

Examples:

1. Consider a system loop for a system with total heating load equal to 210,000 Btuh. The desired temperature drop through the system piping is 20°F. Then the required flow rate is:

$$\text{FLOW} = \frac{210,000}{20 \times 500} = 21 \text{ gpm}$$

SIMPLIFIED:

For 20° temperature drop, FLOW = MBH / 10.

System or zone circulator head requirement

1. The circulator must be capable of delivering the required flow against the head loss that will occur in the piping.
2. Determine the pipe size needed and the resultant head loss using accepted engineering methods. See Figure 46, page 38 for the head loss through the boiler.

Expansion Tank Location

Figure 45, page 38 show typical installation of the system expansion tank. It is highly recommended that you locate the air separator and expansion tank as shown in the suggested piping drawings on pages 37 - 39.

Ensure that the expansion tank size will handle boiler and system water volume and temperature. See tank manufacturer's instructions and ratings for details. Additional tanks may be added to the system if needed to handle the expansion. These tanks may be installed by connecting to tees in the system piping.

CAUTION **Undersized expansion tanks** cause system water to be lost from the relief valve and makeup water to be added through the fill valve. Eventual boiler failure can result due to excessive make-up water addition. Always locate the **cold-water fill connection** at the expansion tank. Never locate this elsewhere.

Diaphragm- or bladder-type tank:

Refer to Figure 45 for suggested piping when using a diaphragm- or bladder-type expansion tank.

NOTICE **Diaphragm- or bladder-type expansion tank—Always check pressure and charge tank with tank removed from system to be sure reading is accurate. Boiler relief valve is set for 30 PSIG.** Operating pressure of system, after temperature expansion above cold fill pressure, should not exceed 24 PSIG to avoid weeping of relief valve.

Install an automatic air vent on top of the air separator, per separator manufacturer's instructions.

Figure 44 Maximum and minimum flow rates through boiler heat exchanger

Boiler Model	MAX Flow Rate 20° F temperature rise GPM	MIN Flow Rate 50° F temperature rise GPM	Flow Rate Delta T1 protection 67° F temperature rise GPM
FS-80	7.9	2.9	2.3
FS-120	12.0	4.3	3.4
FS-155	15.2	6.1	4.5

17 Primary/Secondary System Piping *(continued)*

Figure 45 Piping to diaphragm (or bladder) expansion tank

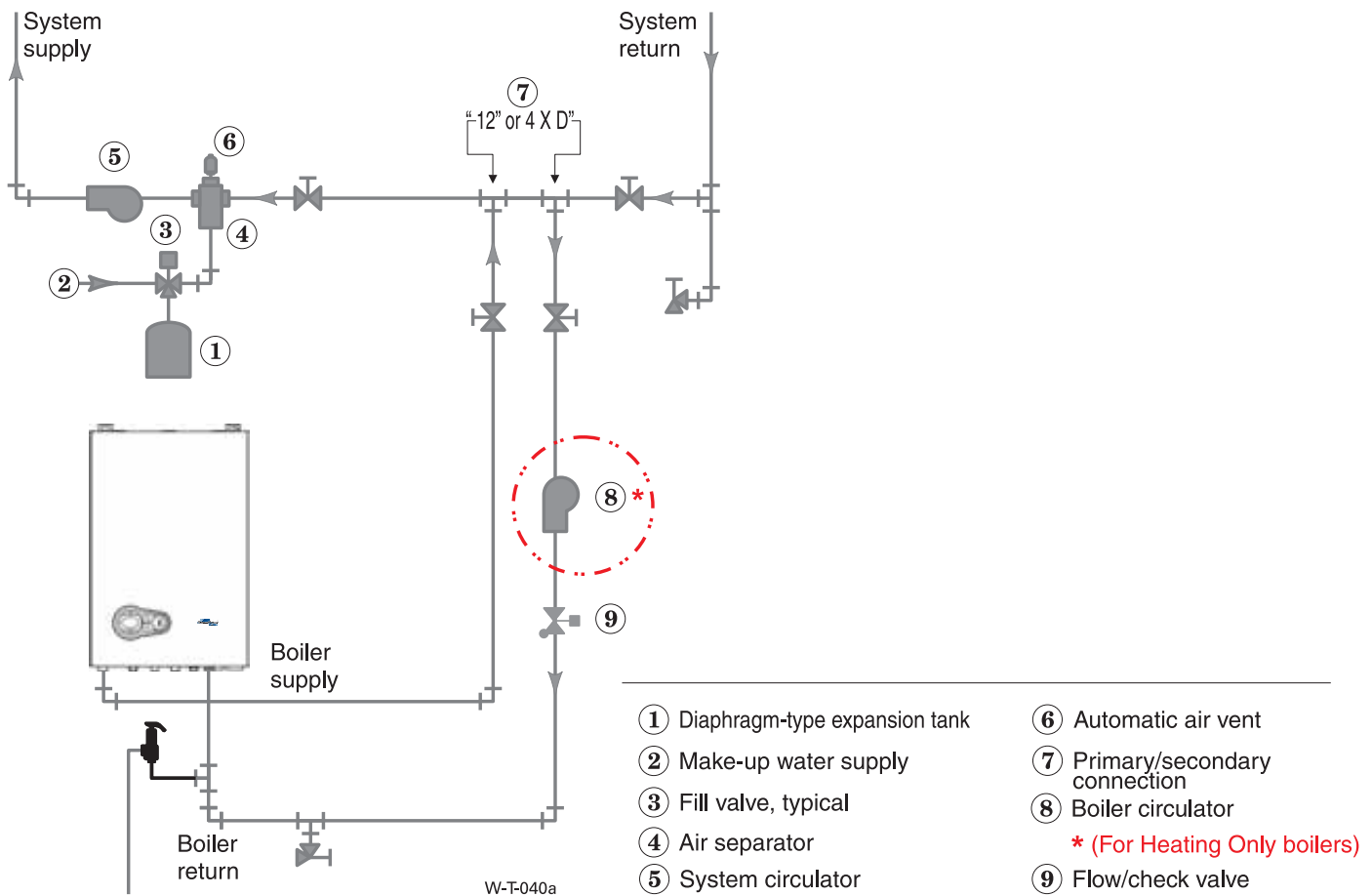


Figure 46 Pressure drop through FreeStyle® 80/120/155 heat exchanger (graphs and table)

Boiler Model	BOILER dT (°F)	(GPM) @ 92% Eff.	Boiler Head Loss (ft. w.c.)	Piping Est. Head Loss - Ft. (Typical Near Boiler)		Total Loss - Ft. (Boiler + Near Boiler Piping)		Recommended Circulators		
				3/4" Pipe	1" Pipe	3/4" Pipe	1" Pipe	3/4" Pipe	1" Pipe	1-1/4" Pipe
FS-80 HEAT ONLY	20	7.4	7.8	12.5	3.0	20.3	10.8	A	B,C,D	---
	30	4.9	4.0	6.0	1.5	10.0	5.5	B,C,D,E	B,C,D,E	
	40	3.7	2.7	3.5	0.8	6.2	3.5	B,C,D,E	B,C,D,E	
FS-120 HEAT ONLY	20	11.0	14.4	Not Recommended	6.0	Not Recommended	20.4	Not Recommended	A,F	---
	30	7.3	7.5		3.0		10.5		B,C,D	
	40	5.5	4.6		1.8		6.4		B,C,D,E	
FS-155 HEAT ONLY	20	14.3	35.6	Recommended	9.6	Recommended	45.8	Recommended	---	---
	30	9.5	16.4		4.6		21.0		F	F
	40	7.1	9.2		2.8		12.0		A,B,D	A,B,D

Notes:

1. Operating point with current Grundfos pump inside the boiler.
2. Combi pump included in the boiler is sized properly for boiler loop.

Circulator Legend:

- A - Taco 0014
- B - Taco 0015
- C - Grundfos UPS 15-58
- D - B&G NRF 25
- E - Taco 007
- F - Taco 0011

17 Primary/Secondary System Piping (continued)

Closed-type expansion tank:

CAUTION DO NOT use a closed-type tank if connecting to a water heater that is equipped with an automatic air vent.

Figure 47, shows suggested piping when using a closed-type expansion tank, in which the air is directly in contact with tank water.

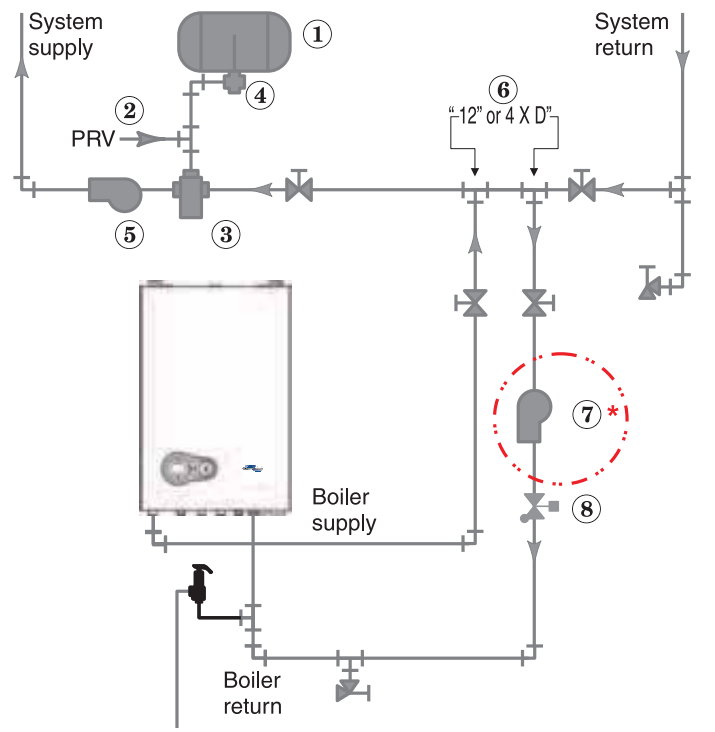
Connect piping (1/2" or 3/4") from the air separator outlet to the tank fitting. Slope any horizontal piping a minimum of 1 inch per 5 feet of horizontal pipe.

Always use a **tank fitting** such as the B&G Tank-trol or Taco Taco-trol (shown). The fitting reduces gravity flow of water in the piping to the tank, avoids air bubbling through the tank water, and provides the proper fill height in the tank.

CAUTION Correct all leaks in the system or tank piping. Leaks allow air to escape from the system and will cause water-logging of the tank. This will result in water loss through the boiler relief valve due to over-pressurization. NEVER use an automatic air vent in a system equipped with a closed-type expansion tank. The air removed from the system will cause water-logging of the expansion tank.

NOTICE Closed-type expansion tank—Follow tank manufacturer's instructions for filling the tank. Typical tank sizing provides for approximately 12 PSIG when the tank is filled to the normal level and system water is cold. Note that boiler relief valve is set for 30 PSIG. Operation pressure of system, after temperature expansion above cold fill pressure, should not exceed 24 PSIG to avoid weeping of relieve valve.

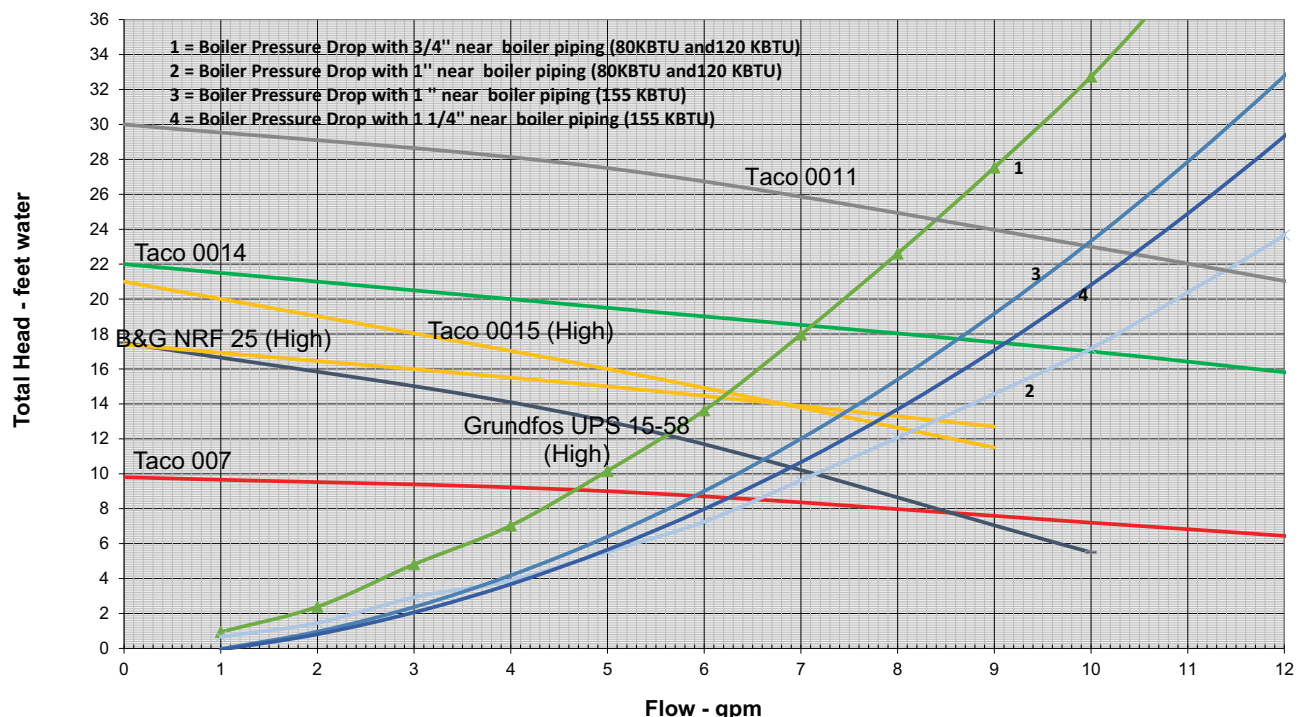
Figure 47 Piping to closed-type expansion tank



- ① Closed-type expansion tank
 - ② PRV Fill valve
 - ③ Air separator
 - ④ Tank fitting
 - ⑤ System circulator
 - ⑥ Primary/secondary connection
 - ⑦ Boiler circulator
 - ⑧ Flow/check valve
- * (For Heating Only boilers)

WT-041a

Graph 1 Pressure drop through FreeStyle® 80/120/155 heat exchanger



17 Primary/Secondary System Piping *(continued)*

Install relief valve

1. Install relief valve in $\frac{3}{4}$ " x $\frac{3}{4}$ " x $\frac{3}{4}$ " (for FS-80/120) or 1" x 1" $\frac{3}{4}$ " (for FS-155) tee piped from boiler supply (Figure 6, page 11).
2. Pipe the relief valve only as shown, in the location shown.
3. Connect discharge piping to safe disposal location, following guidelines in the **WARNING** below.

▲WARNING

To avoid water damage or scalding due to relief valve operation, as per local or state codes:

Install relief valve **ONLY** with the spindle vertical, as shown in illustrations in this manual.

Discharge line must be connected to relief valve outlet and run to a safe place of disposal. Terminate the discharge line in a manner that will prevent possibility of severe burns or property damage should the valve discharge. Locate away from the top of the boiler.

Discharge line must be as short as possible and be the same size as the valve discharge connection throughout its entire length.

Discharge line must pitch downward from the valve and terminate at least 6" above the floor drain where any discharge will be clearly visible.

The discharge line shall terminate plain, not threaded, with a material serviceable for temperatures of 375 °F or greater.

Do not pipe the discharge to any place where freezing could occur.

No shutoff valve shall be installed between the relief valve and boiler, or in the discharge line. Do not plug or place any obstruction in the discharge line.

Test the operation of the valve after filling and pressurizing system by lifting the lever. Make sure the valve discharges freely. If the valve fails to operate correctly, replace it with a new relief valve.

Failure to comply with the above guidelines could result in failure of the relief valve to operate, resulting in possibility of severe personal injury, death or substantial property damage.

17 Primary/Secondary System Piping *(continued)*

Zone Valve zoning – primary/secondary

(Shown with optional DHW piping)

See Figure 48.

1. This configuration is for zone valve systems using a boiler loop connected as a secondary circuit off of a primary system loop. Systems whose flow characteristics do not comply with those listed in Figure 45, page 38 must pipe the boiler loop as a secondary circuit as show.
2. Systems zoned with zone valves **MUST** use a by-pass pressure regulator.
3. Install a system circulator (supplied by installer) capable of delivering the proper flow and head as shown.

Expansion Tank required

1. Provide a system expansion tank following the guidelines on pages 37 or 39.
2. **DO NOT** use a closed-type tank if connecting to a boiler that is equipped with an automatic vent.

Domestic Hot Water (DHW) tank, if used

1. DHW direct connection—Pipe from the near-boiler piping to the DHW tank's boiler connections as shown.
2. DHW as zone—A DHW tank can be connected as a zone if a DHW tank is **NOT** already connected to the boiler. To provide DHW priority operation, use a zone controller. See notices on page 51 to ensure compliance with the 2007 Energy Act.
3. DHW Priority operation—The FreeStyle® control turns off space heating to the HEAT zones during domestic water heating calls on the DHW input. The MAX ON TIME setting can be adjusted to limit how long this occurs. Set the MAX ON TIME to "0" to disable domestic priority. See page 65 for setting instructions.
4. If **NOT** connecting an indirect water heater, do not use the DHW input or DHW Circulator output on the FreeStyle® control.

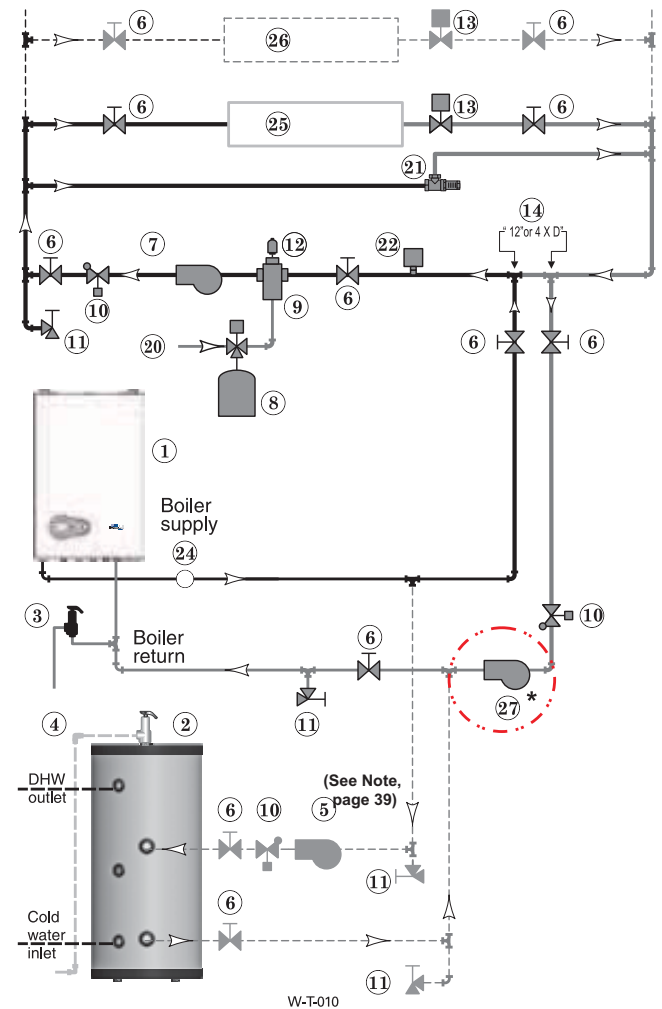
NOTICE Overriding the Outdoor Reset function by connecting space heating zones to inputs and outputs intended for DHW applications may violate **Section 303 of the 2007 Energy Act**. See page 127 for compliance information and exemptions.

NOTICE Wiring the Indirect tank aquastat to the Heating Only Boiler, refer to Section 21 - Field Wiring.

Controlling the Zones

1. The FreeStyle® control can be used to control space heating only, domestic water heating only, or both. Refer to field wiring, beginning on page 51, for instructions on wiring to zone valves.

Figure 48 Zone valve zoning — primary/secondary connection — a system circulator is required



2. The boiler and zone valves can also be operated by a zone controller.

NOTICE Connect zone valve end switches to HEAT input. Connect system circulator to HEAT Circ. output.

CAUTION Use isolation relays if connecting 3-wire zone valve end switches to the HEAT input.

LEGEND for Figure 48.

Note: This is a common legend for all piping diagrams, Not all items listed appear in every figure.

1 FreeStyle® wall mount boiler	12 Auto air vent	21 By-pass pressure regulator, REQUIRED for zone valve systems unless other provision is made
2 Indirect Water Heater, if used	13 Zone valves	22 High limit temperature control
3 Relief valve, supplied by installer, field piped — MUST be piped to boiler supply connection — see page 9 for information	14 Primary/secondary connection (tees no more than 12 inches apart)	23 Zone circulator
4 Relief valve piping to drain — see page 40	15 Expansion tank, closed type, if used (some chiller systems may use a diaphragm-type expansion tank)	24 Pressure/temperature gauge, supplied with boiler, field piped
5 DHW circulator	16 Water chiller	25 Heating circuits
6 Isolation valves	17 Check valve	26 Additional heating circuits, if any
7 System circulator	18 Y-strainer	27 Boiler circulator, *(For Heating Only boilers, In the Combi boiler the circulator is already inside the boiler jacket).
8 Expansion tank, diaphragm type, if used	19 Balancing valve	28 Mixing valve, if any
9 Air separator	20 Make-up water supply – Use applicable codes to determine if backflow preventers, pressure reducing valves, and fill valves may be required	
10 Flow/check valves		
11 Purge/drain valves (Installer supplied)		

17 Primary/Secondary System Piping *(continued)*

Circulator zoning – primary/secondary

(Shown with optional DHW piping)

See Figure 49.

1. This configuration is for circulator-zoned systems using a boiler loop connected as a secondary circuit off of a primary system loop. Systems zoned with circulators must pipe the boiler loop as a secondary circuit as show.
2. Install a separate circulator (supplied by installer) for each zone capable of delivering the proper flow and head as shown.

Expansion Tank required

1. Provide a system expansion tank following the guidelines on pages 37 or 39.
2. **DO NOT** use a closed-type tank if connecting to a boiler that is equipped with an automatic vent.

Domestic Hot Water (DHW) tank, if used

1. DHW direct connection — Pipe from the near-boiler piping to the DHW tank's boiler connections as shown.
2. DHW as zone—A DHW tank can be connected as a zone if a DHW tank is **NOT** already connected to the boiler. To provide DHW priority operation, use a zone controller. See notices on page 51 to ensure compliance with the 2007 Energy Act.
3. DHW Priority operation—The FreeStyle® control turns off space heating to the HEAT zones during domestic water heating calls on the DHW input. The MAX ON TIME setting can be adjusted to limit how long this occurs. Set the MAX ON TIME to “0” to disable domestic priority. See page 65 for setting instructions.
4. If **NOT** connecting an indirect water heater, do not use the DHW input or DHW Circulator output on the FreeStyle® control.

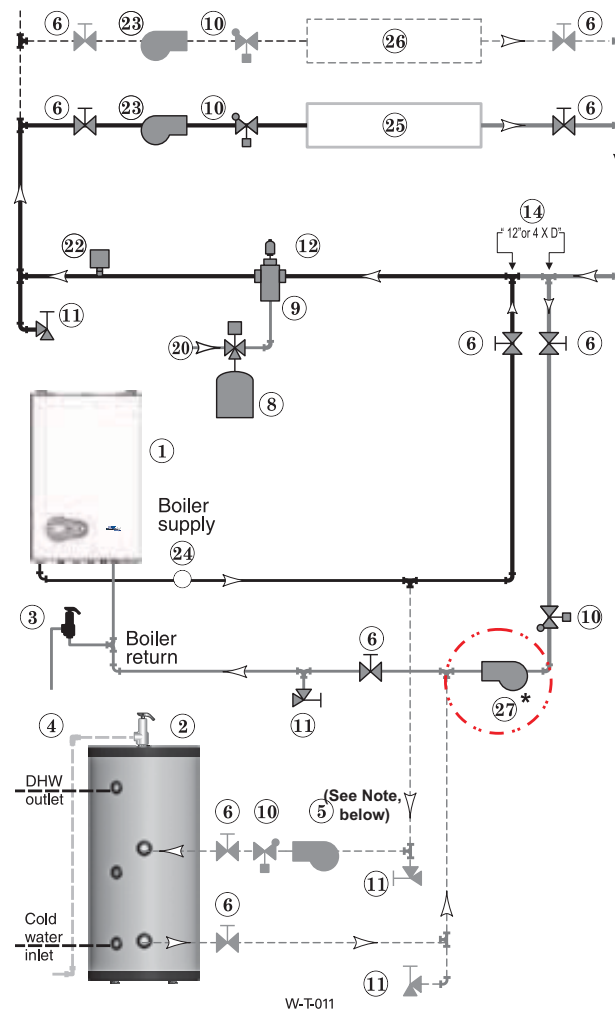
NOTICE Overriding the Outdoor Reset function by connecting space heating zones to inputs and outputs intended for DHW applications may violate **Section 303 of the 2007 Energy Act**. See page 127 for compliance information and exemptions.

NOTICE Wiring the Indirect tank aquastat to the Heating Only Boiler, refer to Section 21 - Field Wiring.

Controlling the Zones

1. The FreeStyle® control can be used to control space heating only, domestic water heating only, or both. Refer to field wiring, beginning on page 51, for instructions on wiring to circulators.
2. The boiler and circulators can also be operated by a zone controller.

Figure 49 Circulator zoning plus optional DHW piping



NOTE: (Applies to Figures 48, 49 & 50)
Add boiler and tank head loss for pump sizing.

LEGEND for Figure 49 and Figure 50		Note: This is a common legend for all piping diagrams, not all items listed appear in every figure.
1 FreeStyle® wall mount boiler	12 Auto air vent	21 By-pass pressure regulator, REQUIRED for zone valve systems unless other provision is made
2 Indirect Water Heater, if used	13 Zone valves	22 High limit temperature control
3 Relief valve, supplied by Installer, field piped — MUST be piped to boiler supply connection — see page 9 for information	14 Primary/secondary connection (tees no more than 12 inches apart)	23 Zone circulator
4 Relief valve piping to drain — see page 40	15 Expansion tank, closed type, if used (some chiller systems may use a diaphragm-type expansion tank)	24 Pressure/temperature gauge, supplied with boiler, field piped
5 DHW circulator	16 Water chiller	25 Heating circuits
6 Isolation valves	17 Check valve	26 Additional heating circuits, if any
7 System circulator	18 Y-strainer	27 Boiler circulator, *(For Heating Only boilers, In the Combi boiler the circulator is already inside the boiler jacket).
8 Expansion tank, diaphragm type, if used	19 Balancing valve	28 Mixing valve, if any
9 Air separator	20 Make-up water supply – Use applicable codes to determine if backflow preventers, pressure reducing valves, and fill valves may be required	
10 Flow/check valves		
11 Purge/drain valves (Installer supplied)		

17 Primary/Secondary System Piping *(continued)*

Circulator zoning – Multiple temperature zones with primary/secondary

(Shown with optional DHW piping)

See Figure 50.

1. This configuration is for circulator-zoned systems with **high- and low- temperature heating zones** using a boiler loop connected as a secondary circuit off of a primary system loop. Systems zoned with circulators must pipe the boiler loop as a secondary circuit as shown.
2. Install a separate circulator (supplied by installer) for each zone capable of delivering the proper flow and head as shown.

Expansion Tank required

1. Provide a system expansion tank following the guidelines on pages 37 or 39.
2. **DO NOT** use a closed-type tank if connecting to a boiler that is equipped with an automatic vent.

System setup and settings

1. Hi-temp emitters may be baseboards, radiators, fan coils, or heat exchangers.

NOTICE For cast iron radiation and old black iron piping systems a “Dirt separator with a magnet” must be installed on the return piping to protect the boiler heat exchanger.

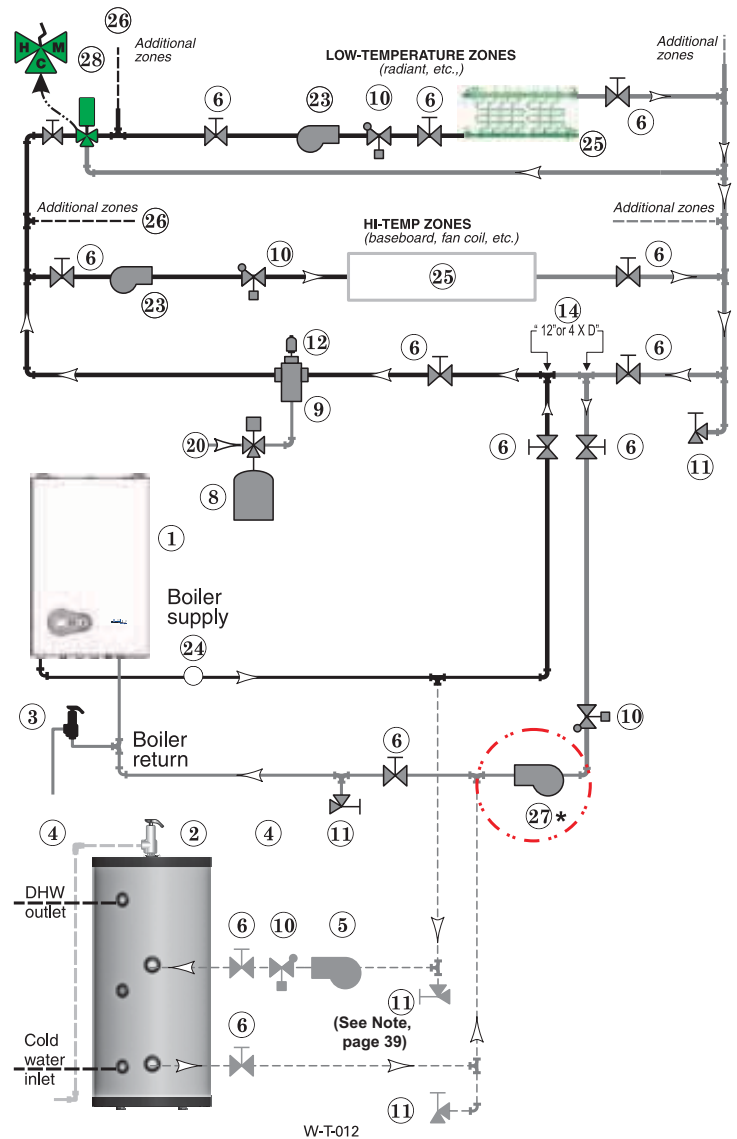
2. Add a mixing device (Figure 50, item 28) to help ensure supply water temperature will not exceed the maximum allowable for the radiant system.
3. Heating zone supply water temperature settings should be selected for the hi-temp zones. The mixing device regulates supply temperature to the lower-temp zones.

NOTICE Boiler operation for fan coil only applications, parameter P02 (page 91) may be set to 20 for faster “ramp up” to boiler set point temperature.

Domestic Hot Water (DHW) tank, if used

1. DHW direct connection—Pipe from the near-boiler piping to the DHW tank’s boiler connections as shown.
2. DHW as zone—A DHW tank can be connected as a zone if a DHW tank is **NOT** already connected to the boiler. To provide DHW priority operation, use a zone controller. See notices on page 51 to ensure compliance with the 2007 Energy Act.
3. DHW Priority operation—The FreeStyle® control turns off space heating to the HEAT zones during domestic water heating calls on the DHW input. The MAX ON TIME setting can be adjusted to limit how long this occurs. Set the MAX ON TIME to “0” to disable domestic priority. See page 65 for setting instructions.
4. If **NOT** connecting an indirect water heater, do not use the DHW input or DHW Circulator output on the FreeStyle® control.

Figure 50 Circulator zoning with high- and low- temperature heating zones



NOTICE Overriding the Outdoor Reset function by connecting space heating zones to inputs and outputs intended for DHW applications may violate **Section 303 of the 2007 Energy Act**. See page 127 for compliance information and exemptions.

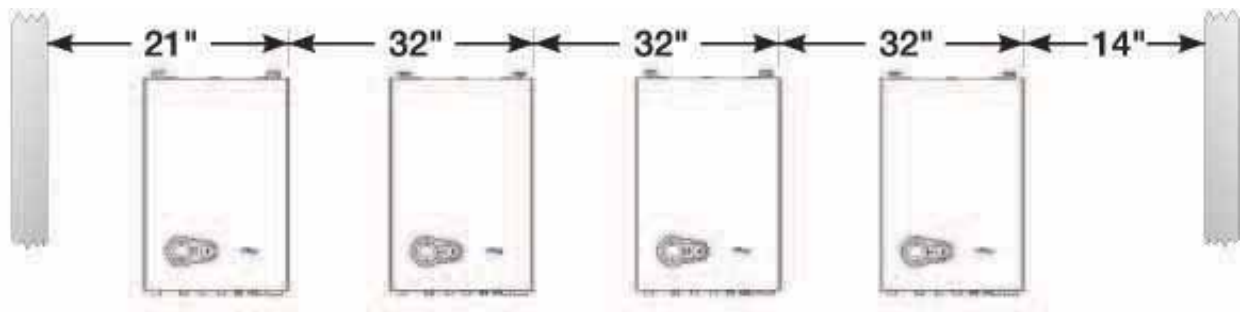
NOTICE Wiring the Indirect tank aquastat to the Heating Only Boiler, refer to Section 21 - Field Wiring.

Controlling the Zones

1. The FreeStyle® control can be used to control space heating only, domestic water heating only, or both.
2. The boiler and circulators can also be operated by a zone controller and in some installations may be needed.

18 Multiple boiler installations

Figure 51 Side-to-side mounting of multiple FreeStyle® boilers



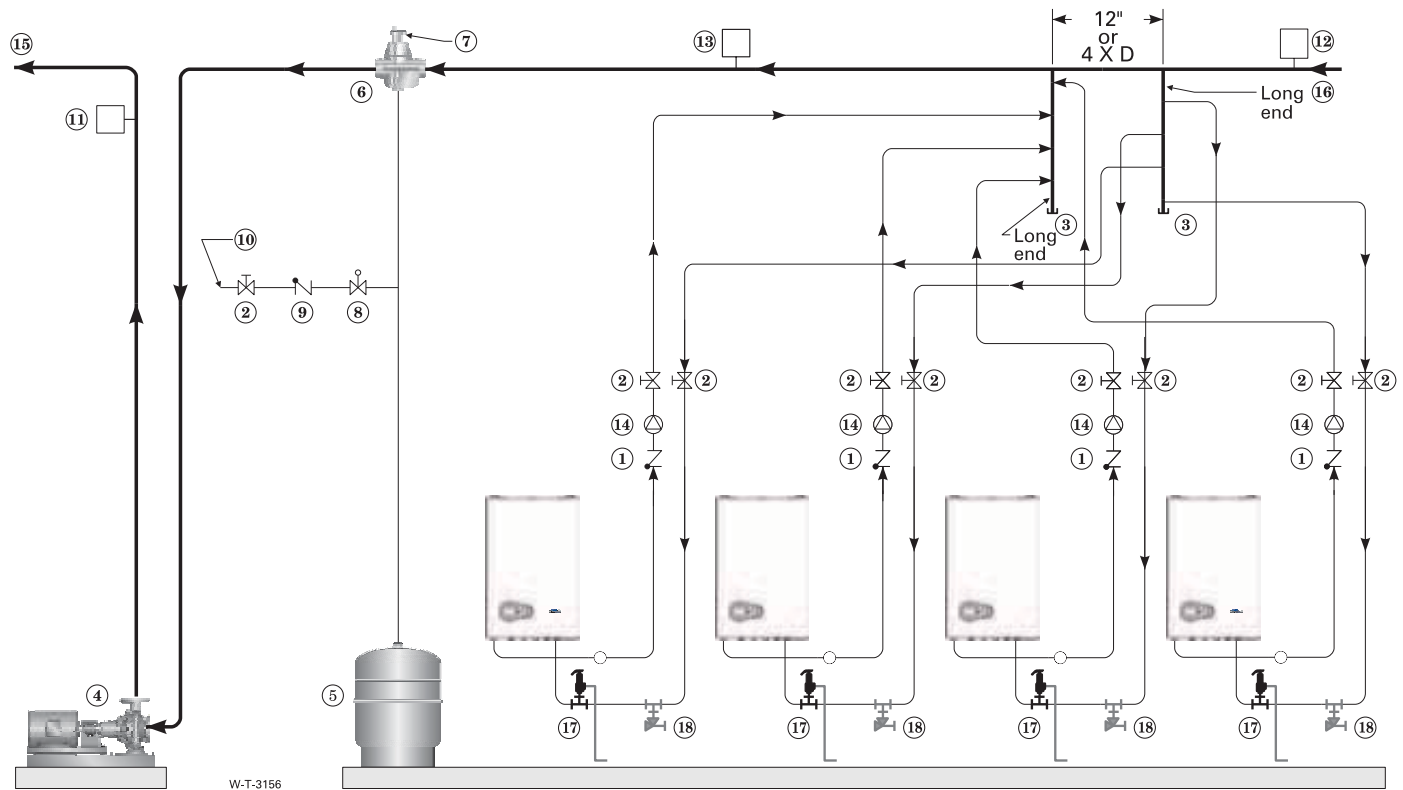
W-T-3151

Placing multiple boilers

1. Locate multiple boilers with spacings shown in Figure 51.
2. Provide indicated clearances around boilers for access and servicing. If recommended dimensions are not possible, provide at least the minimum clearances given on page 5. Also follow local codes.
3. Provide a minimum 36-inch walkway in front of the boilers to ensure accessibility.
4. Unpack, assemble and mount boilers according to instructions in this manual.
5. Provide clearance for installation of venting, air piping, gas piping, expansion tank, primary circulator and other accessories.

18 Multiple boiler installations (continued)

Figure 52 Piping schematic — typical piping for multiple FreeStyle® Heating Only boilers



Legend for Figure 52

- | | |
|--|--|
| 1 Flow/check valve | 10 Cold water supply |
| 2 Isolation valves (when used) | 11 Supply water temperature control (when used) |
| 3 Cap | 12 Low water cutoff (when used) (place above primary header) |
| 4 Primary circulator | 13 Water flow switch (when used) |
| 5 Expansion tank (diaphragm type) | 14 Boiler circulators |
| 6 System air eliminator | 15 System supply |
| 7 System automatic air vent | 16 System return |
| 8 Pressure reducing valve | 17 Boiler P/T gauge, relief valve and discharge piping, installed per FreeStyle® Boiler Manual |
| 9 Check valve or backflow preventer, as required by applicable codes | 18 Purge/drain valve |

18 Multiple boiler installations *(continued)*

DHW tank piping with multiple FreeStyle® boilers

DHW direct connection—single tank

1. If BTUH output of a single boiler is sufficient for the DHW tank/demand, pipe the indirect water heater to the last boiler in the firing sequence. This will allow the previous boilers to continue space heating while the last boiler delivers DHW priority.
2. Pipe from the near-boiler piping to the DHW tank's boiler connections as shown in Figure 48, page 41.
3. Connect the DHW tank aquastat directly to the DHW input on the last boiler in the sequence.

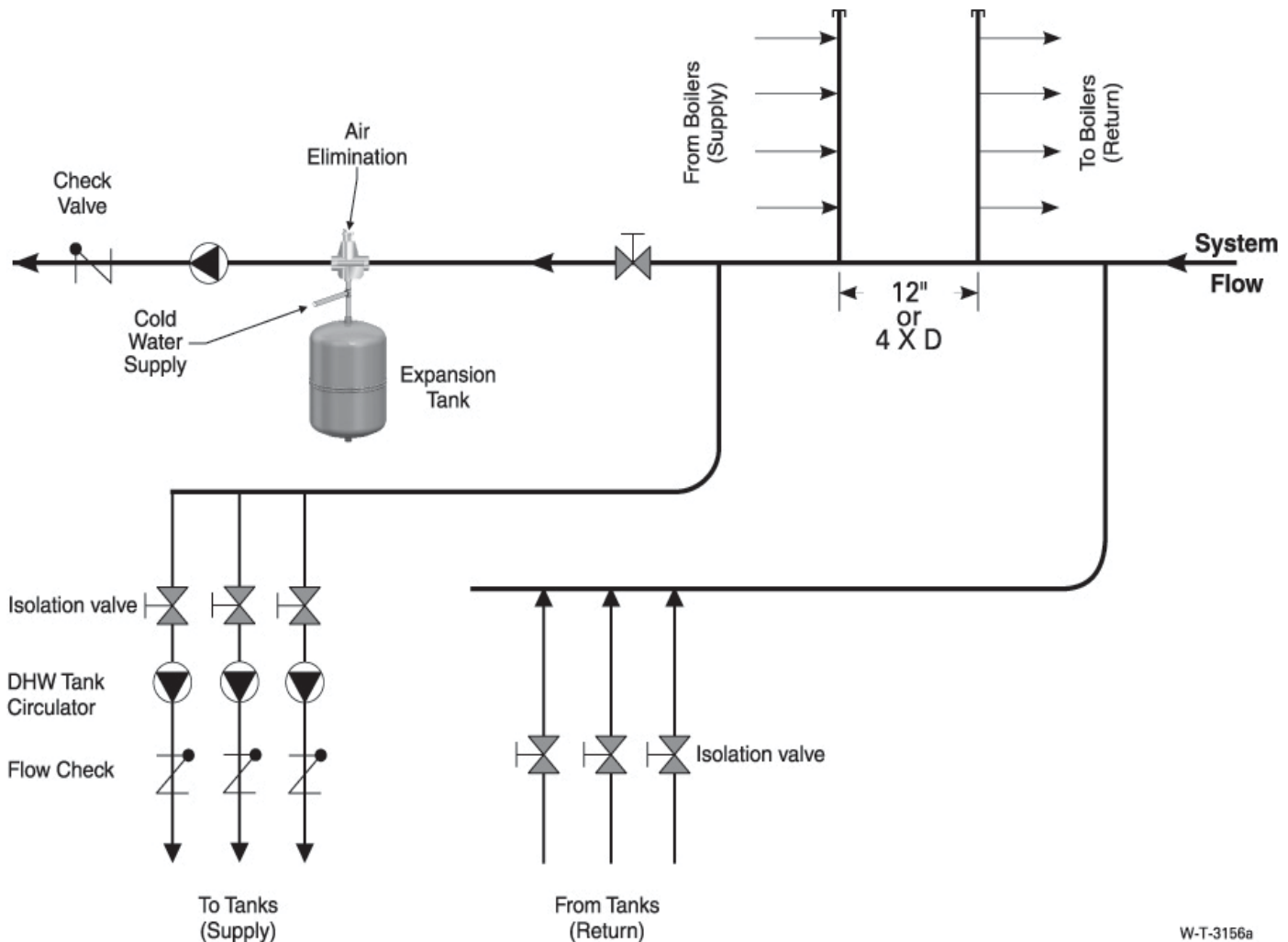
NOTICE

When using a multiple-boiler control with lead boiler rotation, it is recommended that the boiler connected to the DHW tank is always set as the last boiler to operate in the sequence so that space heat can be maintained during times of DHW demand.

DHW tanks as zone—multiple tanks

1. If using multiple DHW tanks or multiple banks of tanks, pipe the tanks to the primary system loop with a secondary connection as shown in Figure 53.
2. DHW tanks are zoned with circulators as shown.
3. If DHW priority is required, use separate zone controllers for DHW and space heating.

Figure 53 Piping layout—typical piping for multiple boilers (4-boiler system shown) with DHW storage heaters grouped as zone in secondary loop off primary system loop. (Heating Only)



W-T-3156a

19 Install condensate line

Prepare condensate trap assembly

This boiler is equipped with an internal air-trap to drain off condensate.

1. Remove the condensate trap kit from the accessories bag.
2. See Figures 54, 55 and 56. The figures below shows the installation of the condensate trap connections.
3. Install the inspection coupling **A** and gasket as shown. Finger tighten securely.
4. Slide the clamp (from the condensate trap kit) onto the flexible drain tube (item **B**), See Figure 55. Push the flexible tube (item **B**) approximately 1-3/4" (Figure 55) onto the end of the tube (bottom of boiler) as shown in Figure 54.

Figure 54 Condensate trap assembly

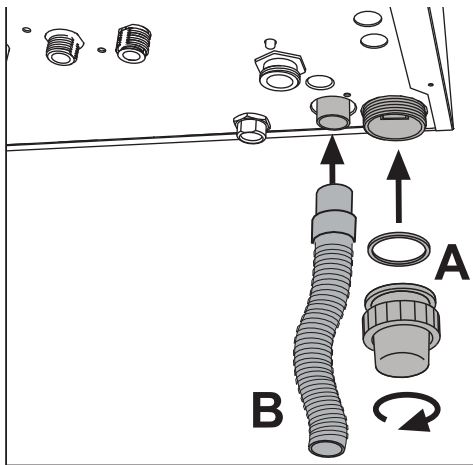
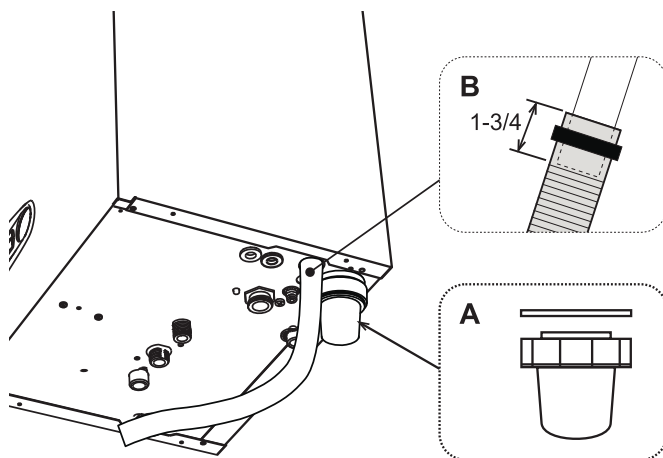


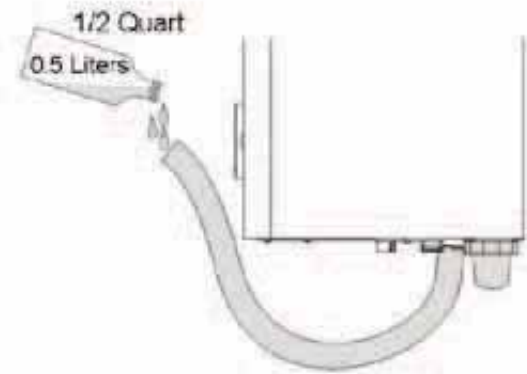
Figure 55 Condensate trap connection



WARNING

The condensate trap must be in place during all operation. Make sure the trap is securely attached to the condensate outlet and that the condensate discharge line is in good condition and installed per this manual. Failure to comply could result in severe personal injury, death or substantial property damage.

Figure 56 Filling the condensate trap assembly



5. Fill the air-trap with approximately 1/2 quart (0.5 liters) of water and connect the condensate drain tube to the condensate drain system

Condensate drain system

1. **Install condensate drain by connecting tubing or PVC pipe to the flexible drain line. Run the drain tubing or piping to a floor drain or condensate pump. The flexible drain line will fit in a 3/4" PVC coupling. Run minimum 1/2" PVC for the piping to drain or condensate pump.**

NOTICE

Use materials approved by the authority having jurisdiction. In the absence of other authority, PVC and CPVC pipe must comply with ASTM D1785, F441 or D2665. Cement and primer must comply with ASTM D2564 or F493.

2. Select a condensate pump (if used) that is approved for use with condensing boilers and furnaces. The pump should have an overflow switch to prevent property damage from condensate spillage. The pump should have a minimum capacity of 2 GPH for the FreeStyle® 80, 3 GPH for the FreeStyle® 120 or 4 GPH for the FreeStyle® 155.
3. When sizing condensate pumps, make sure to include the total load of all appliances connected to it.

CAUTION

The condensate line must remain unobstructed, allowing free flow of condensate. If condensate is allowed to freeze in the line or if the line is obstructed in any other manor, condensate can exit from the boiler tee, resulting in potential water damage to property.

NOTICE

Condensate from the boiler will be slightly acidic (typically with a pH from 3.2 to 4.5). Install a neutralizing filter when draining into metal pipe and if required by local codes. See Replacement parts section at the end of this manual for the Williamson-Thermoflo kit.

20 Gas piping

▲WARNING FreeStyle® boilers are shipped ready to fire natural gas ONLY. You must install the propane venturi if the boiler will be connected to propane. See page 12. Failure to comply could result in severe personal injury, death or substantial property damage.

Connecting gas supply piping

- Remove jacket door and refer to Figure 57 to pipe gas to boiler.
 - Place a pipe wrench on the gas line inside the jacket when tightening the gas line assembly to the boiler gas connection (item 1).
 - Install steel pipe fittings as shown in Figure 57. All pipe fittings and gas cock are supplied by the installer.
- Use pipe dope compatible with propane gases. Apply sparingly only to male threads of pipe joints so that pipe dope does not block gas flow.

▲WARNING Failure to apply pipe dope as detailed above can result in severe personal injury, death or substantial property damage.

- Connect gas supply piping to the ½" NPT gas cock (item 2).
- Support gas piping with hangers, not by boiler or its accessories.
- Purge all air from gas supply piping.
- Before placing boiler in operation, check boiler and its gas connection for leaks.
 - During any pressure testing at less than 13" w.c., close the gas shutoff valve and disconnect system gas piping. At higher test pressures, disconnect boiler and gas valve from gas supply piping.

▲WARNING Do not check for gas leaks with an open flame — use bubble test. Failure to use bubble test or check for gas leaks can cause severe personal injury, death or substantial property damage.

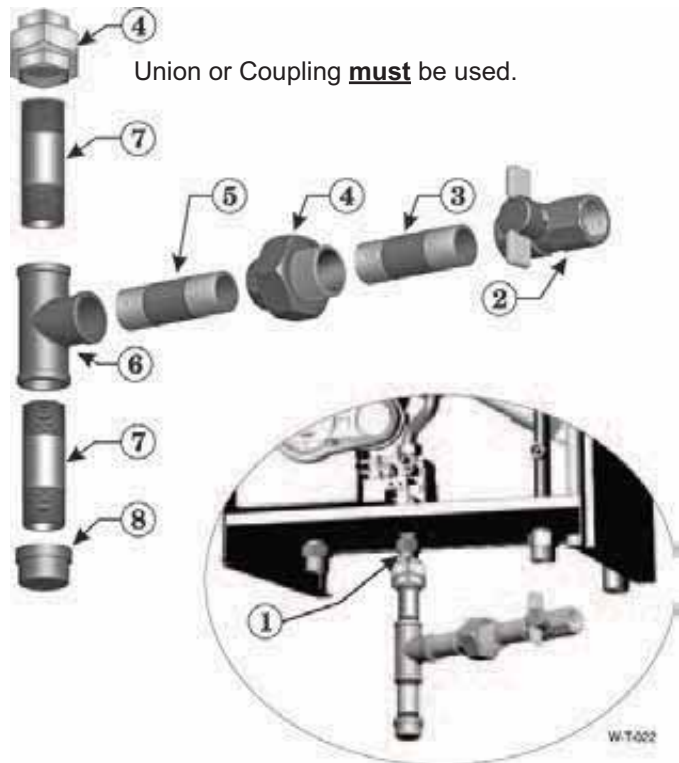
▲WARNING DO NOT adjust or attempt to measure gas valve outlet pressure. The gas valve is factory-set for the correct outlet pressure. This setting is suitable for natural gas and propane. Attempting to alter or measure the gas valve outlet pressure could result in damage to the valve, causing potential severe personal injury, death or substantial property damage.

NOTICE Flexible appliance gas connectors are NOT recommended.

Gas pipe sizing

- See page 16 for gas line sizing information.

Figure 57 Connect gas supply piping (Heating Only boiler shown).



- Boiler gas supply connection, ½" NPT male

ALL OF THE FOLLOWING ARE SUPPLIED BY THE INSTALLER:

- T-handle gas cock, ½" NPT
- Nipple, ½" NPT
- Unions, ½" NPT
- Nipple, ½" NPT
- Tee, ½" NPT
- Nipple, ½" NPT x 6", for drip leg
- Cap, ½" NPT

▲WARNING Use two wrenches when tightening gas piping at boiler, using one wrench to prevent the boiler gas line connection from turning. Failure to support the boiler gas connection pipe to prevent it from turning could damage gas line components.

20 Gas piping *(continued)*

Check gas pressure at inlet to boiler

1. See Figure 58 for location of the gas inlet pressure test port.

Check the operational (working) gas inlet pressure

1. Set up the boiler to operate at maximum rate as described in section “ Test mode” Figure 95, page 70.
2. With the boiler operating at maximum rate check that the operational (working) gas pressure at the inlet gas pressure test port (see above) complies with the requirements of Table 2 .
3. Ensure that this inlet pressure can be obtained with all other gas appliances in the property working.

Measure the gas rate

Measure the gas rate and check against following Table 2:

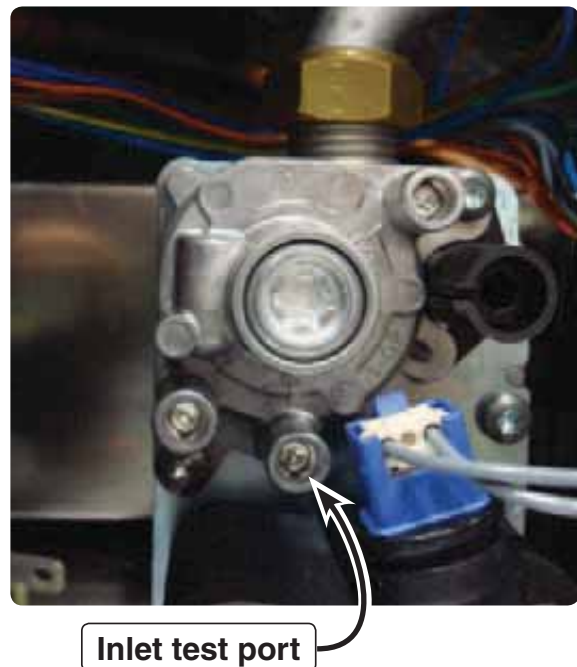
Table 2 Gas rate for Combi and Heating Only boilers

Gas Rate (Natural Gas) After 10 minutes from cold		
Combi Boiler model	Maximum rate	Minimum rate
	ft ³ /h	ft ³ /h
FS-80	78.4	7.8
FS-120	117.6	11.8
FS-155	151.9	15.2

For natural gas or liquefied petroleum (propane) gas, the pressure required at gas valve inlet pressure port (verify minimum gas pressure when all gas appliances are in operation):

- a. Maximum: 13” w.c. with no flow (lockup) or with boiler on.
 - b. Minimum gas pressure, with gas flowing (verify during boiler startup, while boiler is at high fire)
 - FreeStyle® 80: 3.5” w.c.;
 - FreeStyle® 120: 3.5” w.c.;
 - FreeStyle® 155: 3.5” w.c.
 - c. Nominal gas pressure: 11.0” w.c.
4. Install 100% lockup gas pressure regulator in supply line if inlet pressure can exceed 13” w.c. at any time. Adjust lockup regulator for 13” w.c. maximum.

Figure 58 Inlet test port on gas valve



21 Field wiring

⚠ WARNING ELECTRICAL SHOCK HAZARD — For your safety, turn off electrical power supply at service entrance panel before making any electrical connections to avoid possible electric shock hazard. Failure to do so can cause severe personal injury or death.

NOTICE The installation must comply with: National Electrical Code and any other national, state, provincial or local codes or regulations.

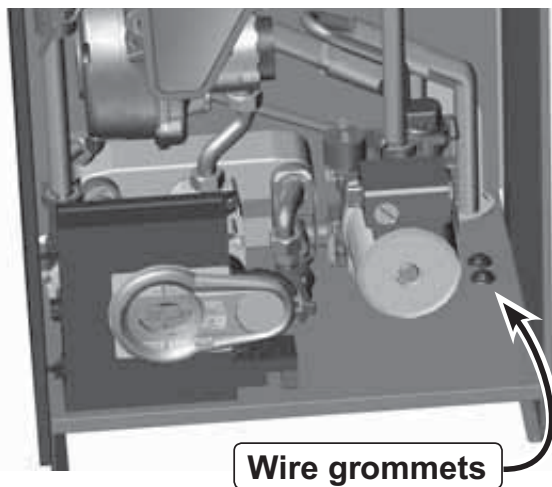
NOTICE Wiring must be N.E.C. Class 1. If original wiring as supplied with boiler must be replaced, use only type 105 °C wire or equivalent. Boiler must be electrically grounded as required by National Electrical Code ANSI/NFPA 70 – latest edition.

FreeStyle® Central Heating and Combi boiler wiring

The boiler is pre-wired and is ready to be plugged into your electrical supply. Receptacle must be a grounded and polarized circuit.

Wire entrances

Figure 59 Thermostat or sensor wiring entrances



All field wiring is made through the bottom of the boiler through two (2) black grommets shown in Figure 59.

Connecting terminals

The electrical connections terminal block can be accessed after removing the front jacket panel. The layout of the terminals for the various connections is shown in Figure 60 or given in the wiring diagram in Figure 66, page 52 or Figure 68, page 54.

Room thermostat

When connecting a room thermostat, connect the thermostat across terminals **R** and **W** for a two (2) -wire thermostat or optional **R, W** and **C** for a three (3) -wire thermostat, see Figure 60, Item 72. The thermostat connector is located on the right side of the boiler.

NOTICE Either a voltage free thermostat or a 24VAC thermostat can be connected to the boiler.

Figure 60 Thermostat terminals Combi and Central Heating and Outdoor sensor (Heating Only Boilers)

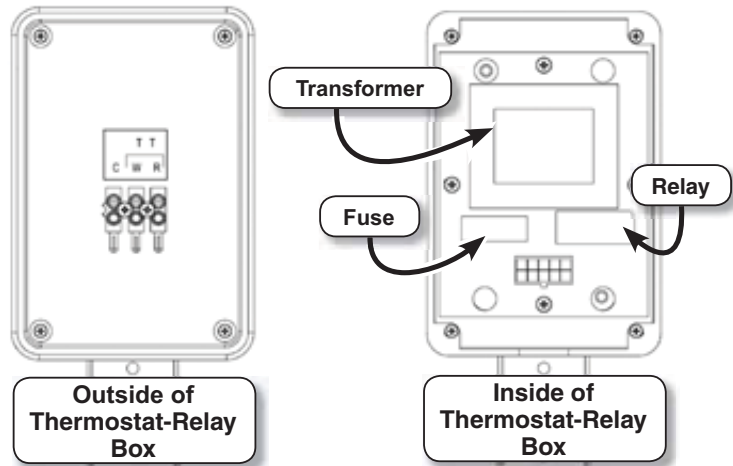
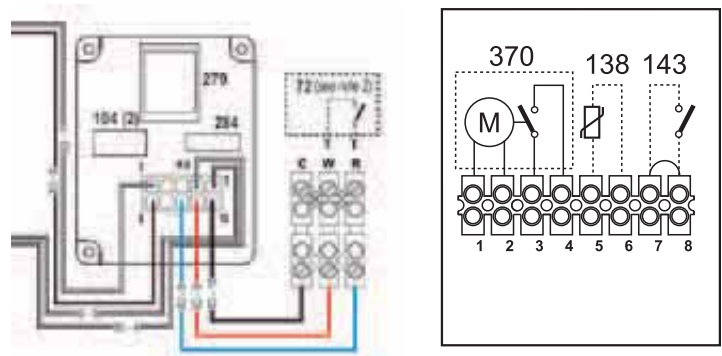


Figure 61 Thermostat-Relay box terminals Combi and Central Heating boilers



21 Field wiring *(continued)*

Outdoor temperature sensor Central Heating Boiler (optional for Combi Boilers)

- Outdoor sensor uses the back connection block, see Figure 60, Item 138, (right side of block ... terminals 5 and 6) for the Heating Only boiler.
- Recommended wire size 22 AWG /100” in length (2-conductor thermostat wire 22 gauge).
- Mount on north exterior wall, shielded from direct sunlight or flow of heat or cooling from other sources, approximately 10 feet above ground level.
- Do NOT run sensor wires with other electrical wires.

The outdoor sensor must be installed unless specifically exempted in the Energy Act statement on page 127.

Figure 62 Outdoor sensor optional for Combi boiler.

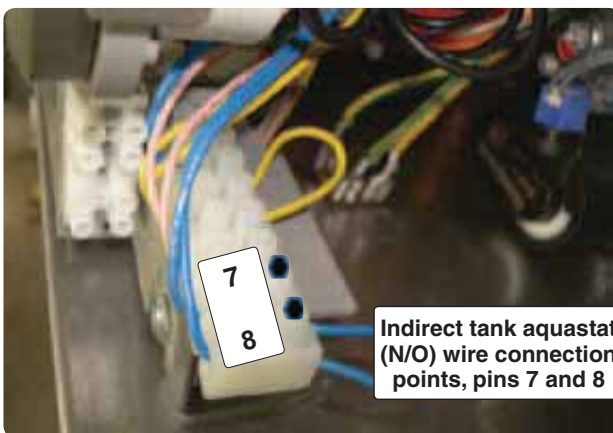


Wiring the Indirect Tank Aquastat

Wiring the indirect tank aquastat to the Heating Only Boiler, will fire the boiler to provide heated boiler water to the indirect tanks heating coil.

- Field supplied; zone panel, with priority zone, indirect circulator, zone valve for indirect tank.
- Connect indirect aquastat N/O contact wires to boiler connections #7 and #8, see Figure 63 below.
- Boiler must be in the “comfort mode” (not “eco” mode) push eco/comfort button to exit “eco” mode, display will Not show “eco” on display when in correct mode.

Figure 63 Indirect tank aquastat connections



Wiring the Circulators (Heating Only Boiler)

The control of the Heating Only model of the FreeStyle boiler is capable of managing two (2) separate circulators, one for the Heating circuit and one for the Domestic Hot water circuit.

The connections are located on the rear part of the control case. In order to access the connector you will have to unscrew the screw located on the lower right corner of the control to enable you to rotate the control and access the connectors. See Figure 64 and Figure 65.

Figure 64 Circulator connectors (Heating Only boilers)

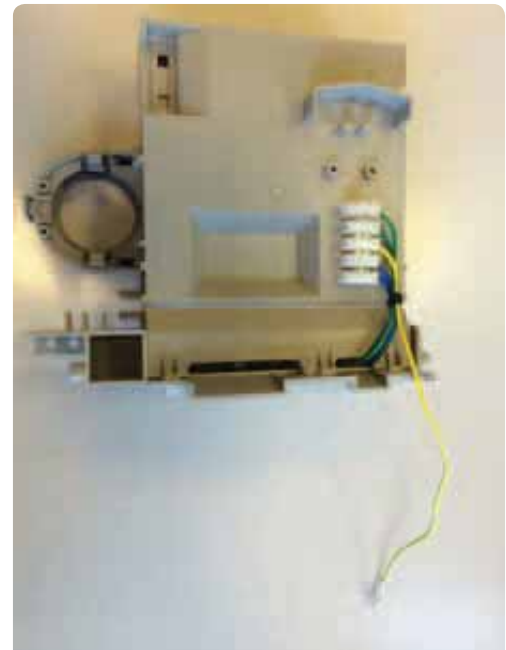
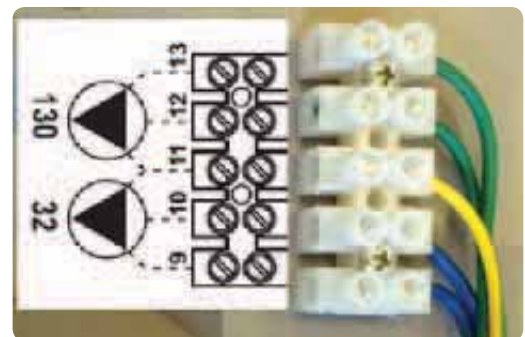


Figure 65 Circulator connectors detail



In Figure 65, terminals 9, 10 and 11 (Item 32) are for connecting the Heating circuit circulator.

Terminals 11, 12, and 13 (Item 130) are for connecting the Domestic Hot water circuit circulator.

The common terminal 11 is ground.

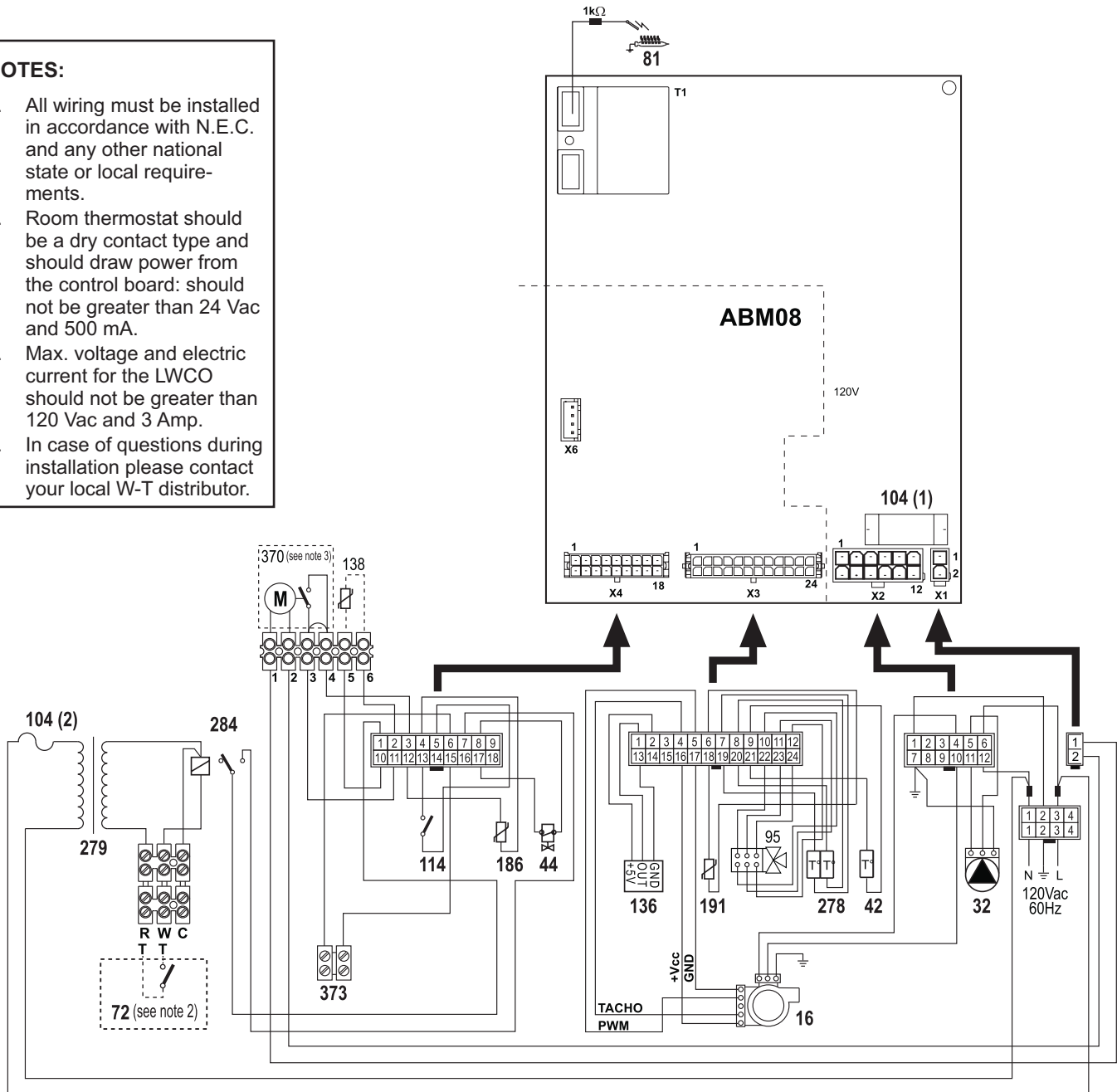
NOTICE Only one circulator may be wired to each connection point.

22 Wiring diagram — FS-80/120 Combi Ladder

Figure 66 FreeStyle® 80/120 Combi Ladder Wiring Diagram

NOTES:

1. All wiring must be installed in accordance with N.E.C. and any other national state or local requirements.
2. Room thermostat should be a dry contact type and should draw power from the control board: should not be greater than 24 Vac and 500 mA.
3. Max. voltage and electric current for the LWCO should not be greater than 120 Vac and 3 Amp.
4. In case of questions during installation please contact your local W-T distributor.



cod. 3541F513

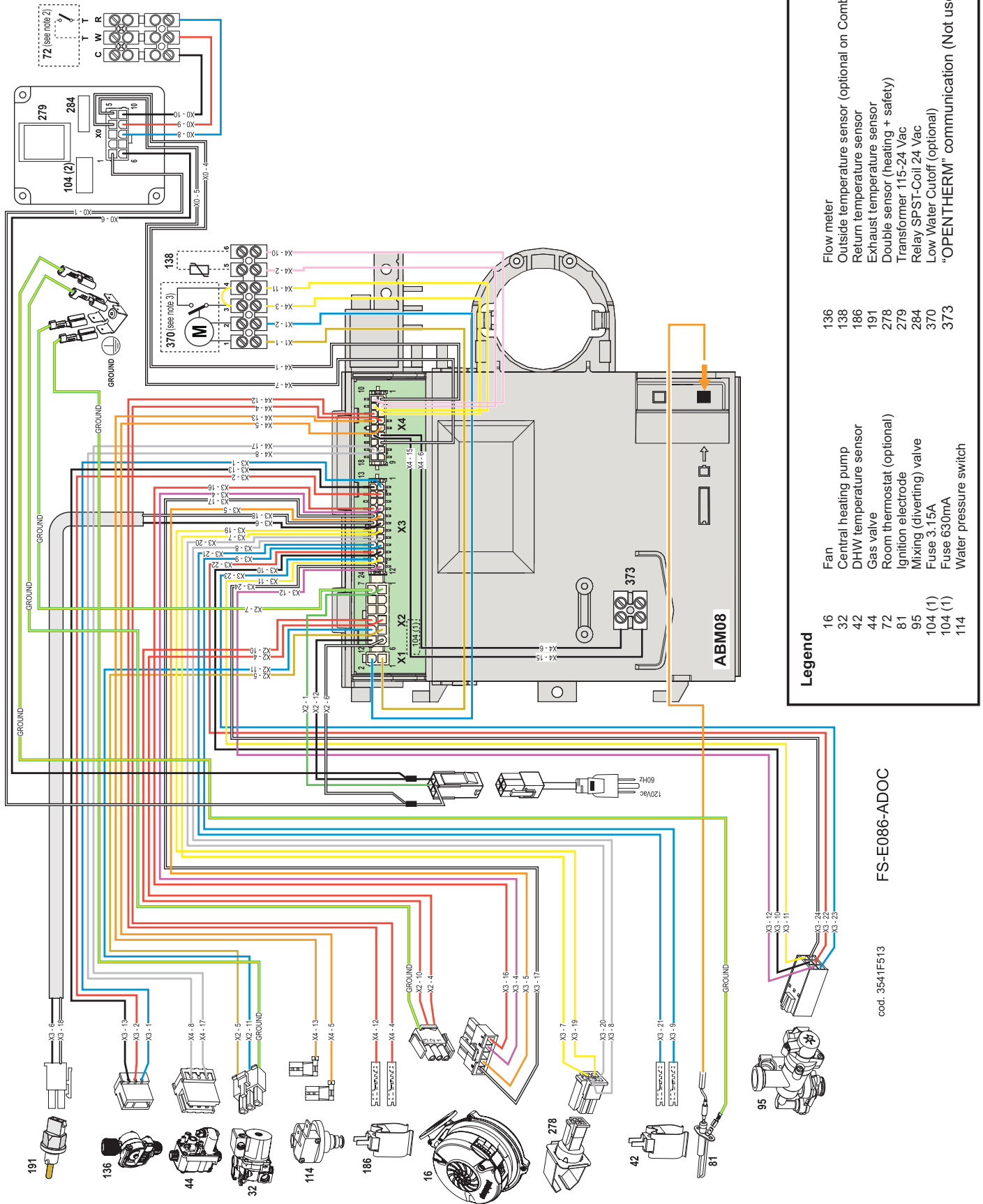
FS-E086-ADOC

Legend

16	Fan	114	Water pressure switch
32	Central heating pump	136	Flow meter
42	DHW temperature sensor	138	Outside temperature sensor (optional on Combi)
44	Gas valve	186	Return temperature sensor
72	Room thermostat (optional)	191	Exhaust temperature sensor
81	Ignition electrode	278	Double sensor (heating + safety)
95	Mixing (diverting) valve	279	Transformer 115-24 Vac
104(1)	Fuse 3.15A	284	Relay SPST-Coil 24 Vac
104 (1)	Fuse 630mA	370	LWCO (optional)
		373	“OPENTHERM” communication (Not used)

22 Wiring diagram — FS-80/120 Combi Schematic

Figure 67 FreeStyle® 80/120 Combi Schematic Wiring Diagram

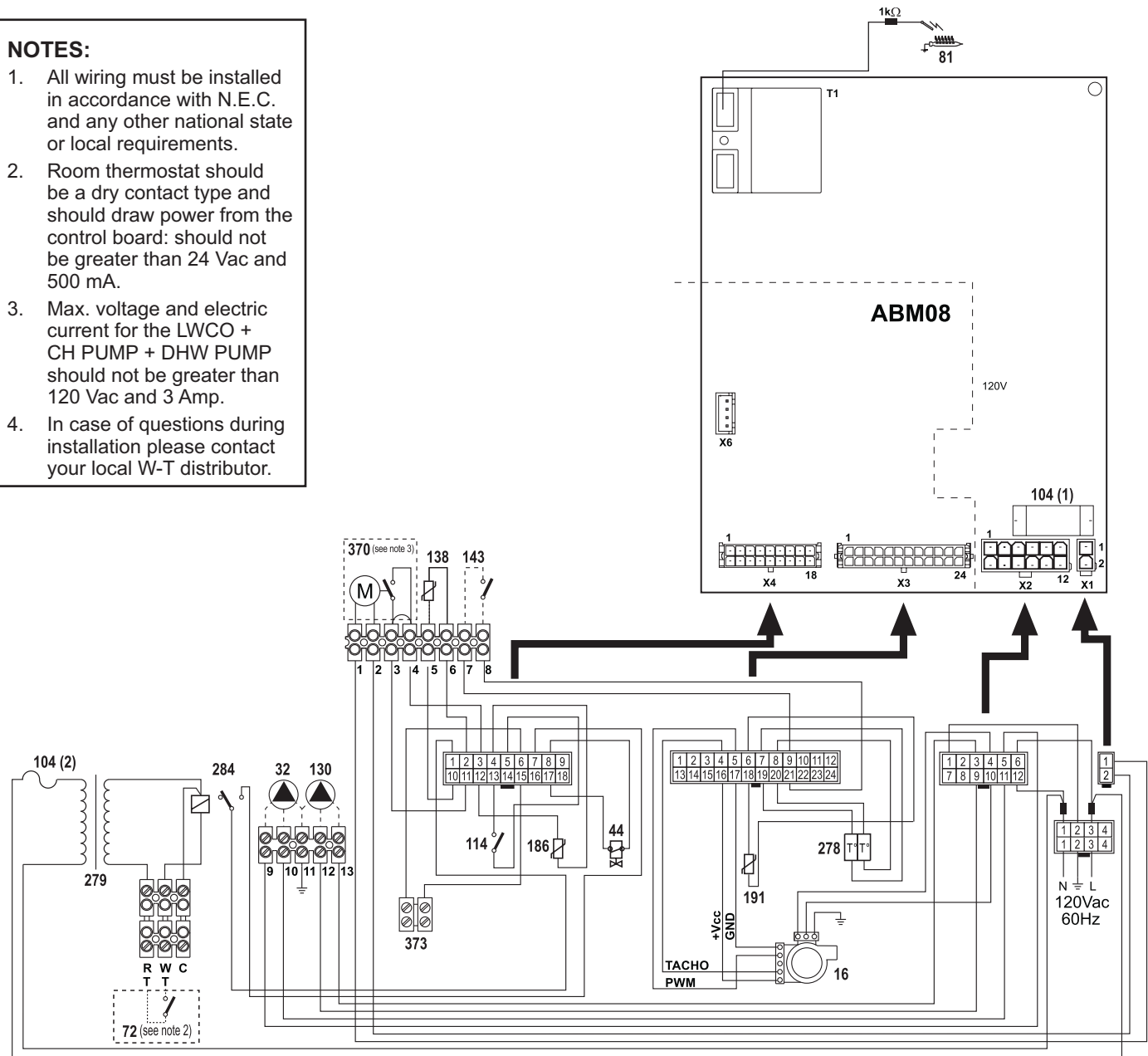


23 Wiring diagram — FS-80/120 Heating Only Ladder

Figure 68 FreeStyle® 80/120 Heating Only Ladder Wiring Diagram

NOTES:

1. All wiring must be installed in accordance with N.E.C. and any other national state or local requirements.
2. Room thermostat should be a dry contact type and should draw power from the control board: should not be greater than 24 Vac and 500 mA.
3. Max. voltage and electric current for the LWCO + CH PUMP + DHW PUMP should not be greater than 120 Vac and 3 Amp.
4. In case of questions during installation please contact your local W-T distributor.



cod. 3541F004

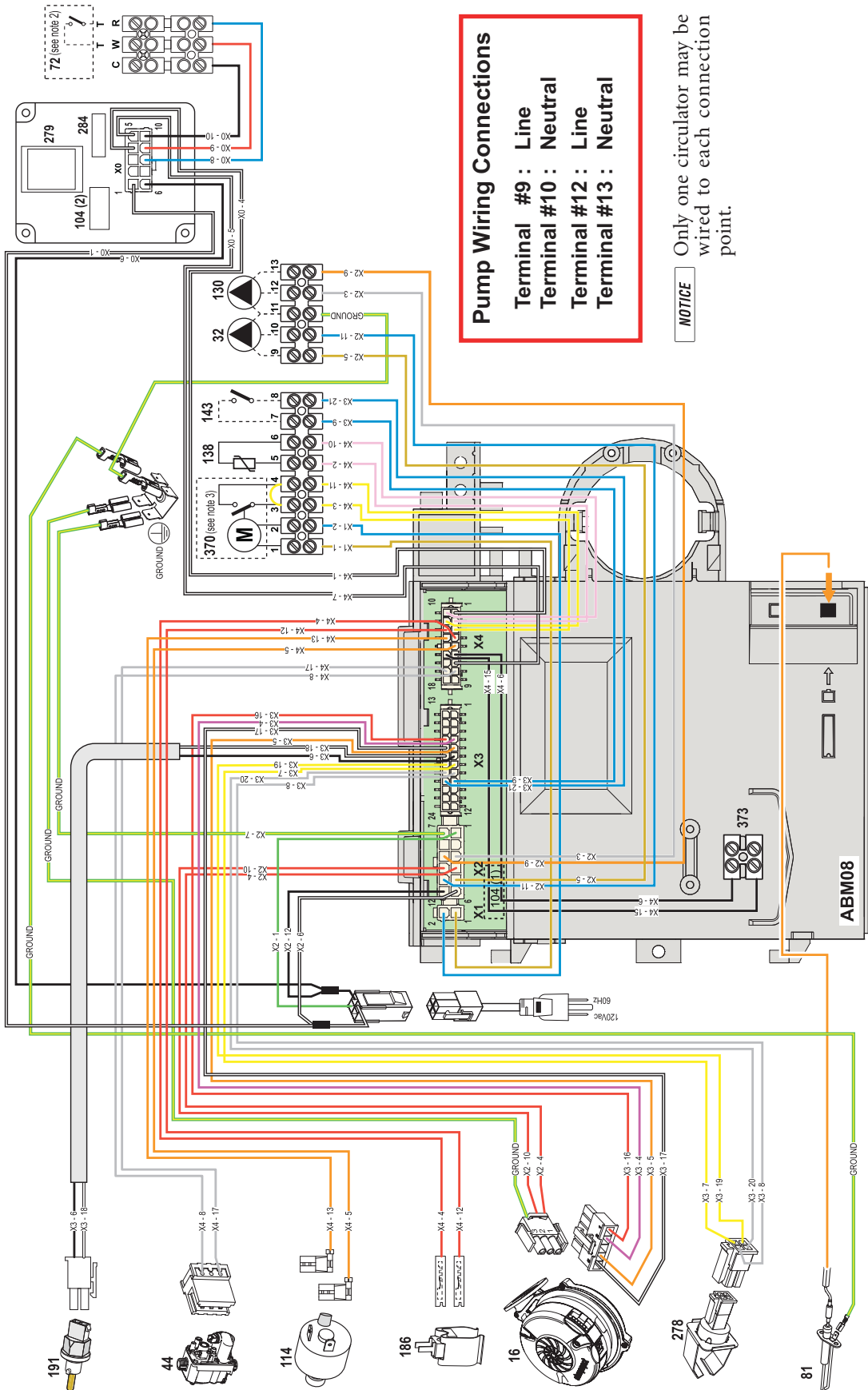
FS-E087-ADOC

Legend

16	Fan	138	Outdoor sensor
32	Central heating pump (not included)	143	DHW tank thermostat (optional)
44	Gas valve	186	Return temperature sensor
72	Room thermostat (optional)	191	Exhaust temperature sensor
81	Ignition electrode	278	Double sensor (heating + safety)
104(1)	Fuse 3.15A	279	Transformer 115-24 Vac
104(1)	Fuse 630mA	284	Relay SPST-Coil 24 Vac
114	Water pressure switch	370	LWCO (optional)
130	DHW Pump (not included)	373	“OPENTHERM” communication (Not used)

23 Wiring diagram — FS-80/120 Heating Only Schematic

Figure 69 FreeStyle® 80/120 Heating Only Schematic Wiring Diagram



Pump Wiring Connections
 Terminal #9 : Line
 Terminal #10 : Neutral
 Terminal #12 : Line
 Terminal #13 : Neutral

NOTICE Only one circulator may be wired to each connection point.

Legend

16	Fan	104(1)	Transformer 115-24 Vac
32	Central heating pump (not included)	104(1)	Relay SPST-Coil 24 Vac
44	Gas valve	114	LWCO (optional)
72	Room thermostat (optional)	130	"OPENTHERM" communication (Not used)
81	Ignition electrode		
104(1)	Fuse 3.15A		
104(1)	Fuse 630mA		
114	Water pressure switch		
130	DHW Pump (not included)		
138	Outdoor sensor		
143	DHW tank thermostat (optional)		
186	Return temperature sensor		
191	Exhaust temperature sensor		
278	Double sensor (heating + safety)		
279	Room thermostat		
284	Ignition electrode		
370	Fuse 3.15A		
373	Fuse 630mA		

FS-E087-ADOC

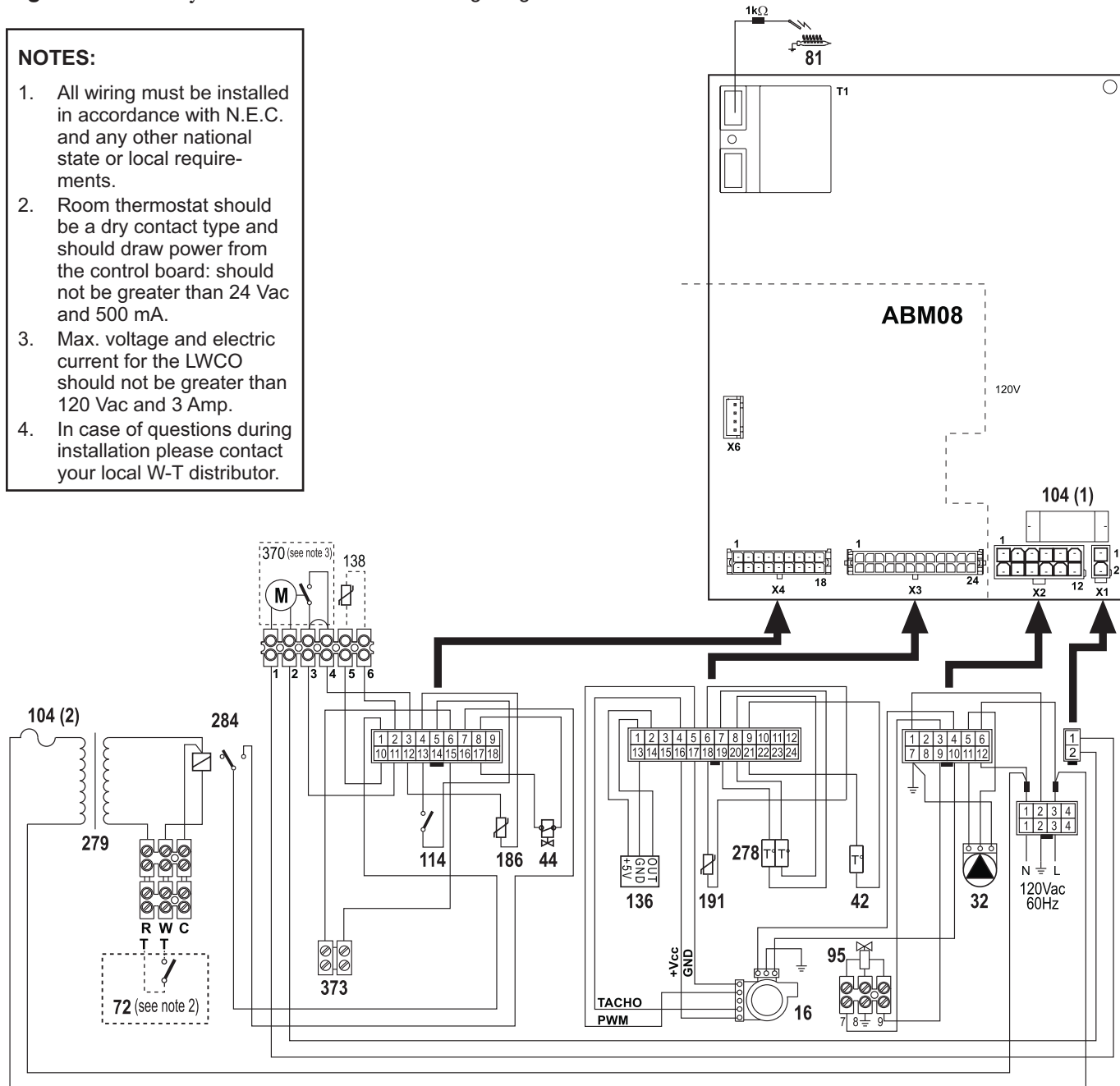
cod. 3541F004

23 Wiring diagram — FS-155 Combi Ladder

Figure 70 FreeStyle® 155 Combi Ladder Wiring Diagram

NOTES:

1. All wiring must be installed in accordance with N.E.C. and any other national state or local requirements.
2. Room thermostat should be a dry contact type and should draw power from the control board: should not be greater than 24 Vac and 500 mA.
3. Max. voltage and electric current for the LWCO should not be greater than 120 Vac and 3 Amp.
4. In case of questions during installation please contact your local W-T distributor.



cod. 35411640

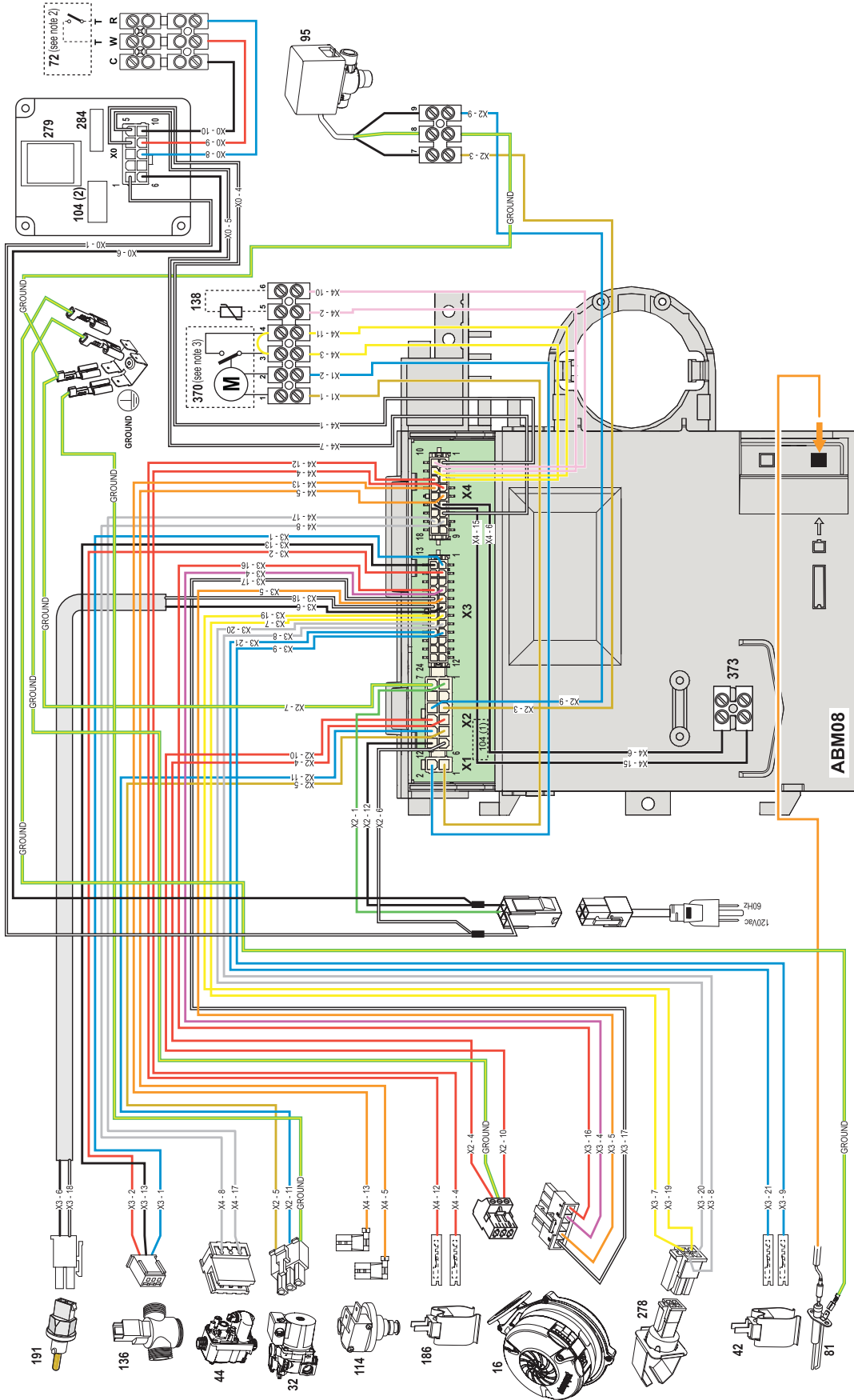
FS-E128-BDOC

Legend

16	Fan	114	Water pressure switch
32	Central heating pump	136	Flow meter
42	DHW temperature sensor	138	Outside temperature sensor (optional on Combi)
44	Gas valve	186	Return temperature sensor
72	Room thermostat (optional)	191	Exhaust temperature sensor
81	Ignition electrode	278	Double sensor (heating + safety)
95	Mixing (diverting) valve	279	Transformer 115-24 Vac
104(1)	Fuse 3.15A	284	Relay SPST-Coil 24 Vac
104 (1)	Fuse 630mA	370	LWCO (optional)
		373	"OPENTHERM" communication (Not used)

23 Wiring diagram — FS-155 Combi Schematic

Figure 71 FreeStyle® 155 Combi Schematic Wiring Diagram



Legend	
16	Fan
32	Central heating pump
42	DHW temperature sensor
44	Gas valve
72	Room thermostat (optional)
81	Ignition electrode
95	Mixing (diverting) valve
104 (1)	Fuse 3.15A
104 (1)	Fuse 630mA
114	Water pressure switch
136	Fan
138	Central heating pump
186	DHW temperature sensor
191	Gas valve
278	Room thermostat (optional)
279	Ignition electrode
284	Mixing (diverting) valve
370	Fuse 3.15A
373	Fuse 630mA
	Water pressure switch
	Flow meter
	Outside temperature sensor (optional on Combi)
	Return temperature sensor
	Exhaust temperature sensor
	Double sensor (heating + safety)
	Transformer 115-24 Vac
	Relay SPST-Coil 24 Vac
	Low Water Cutoff (optional)
	"OPENTHERM" communication (Not used)

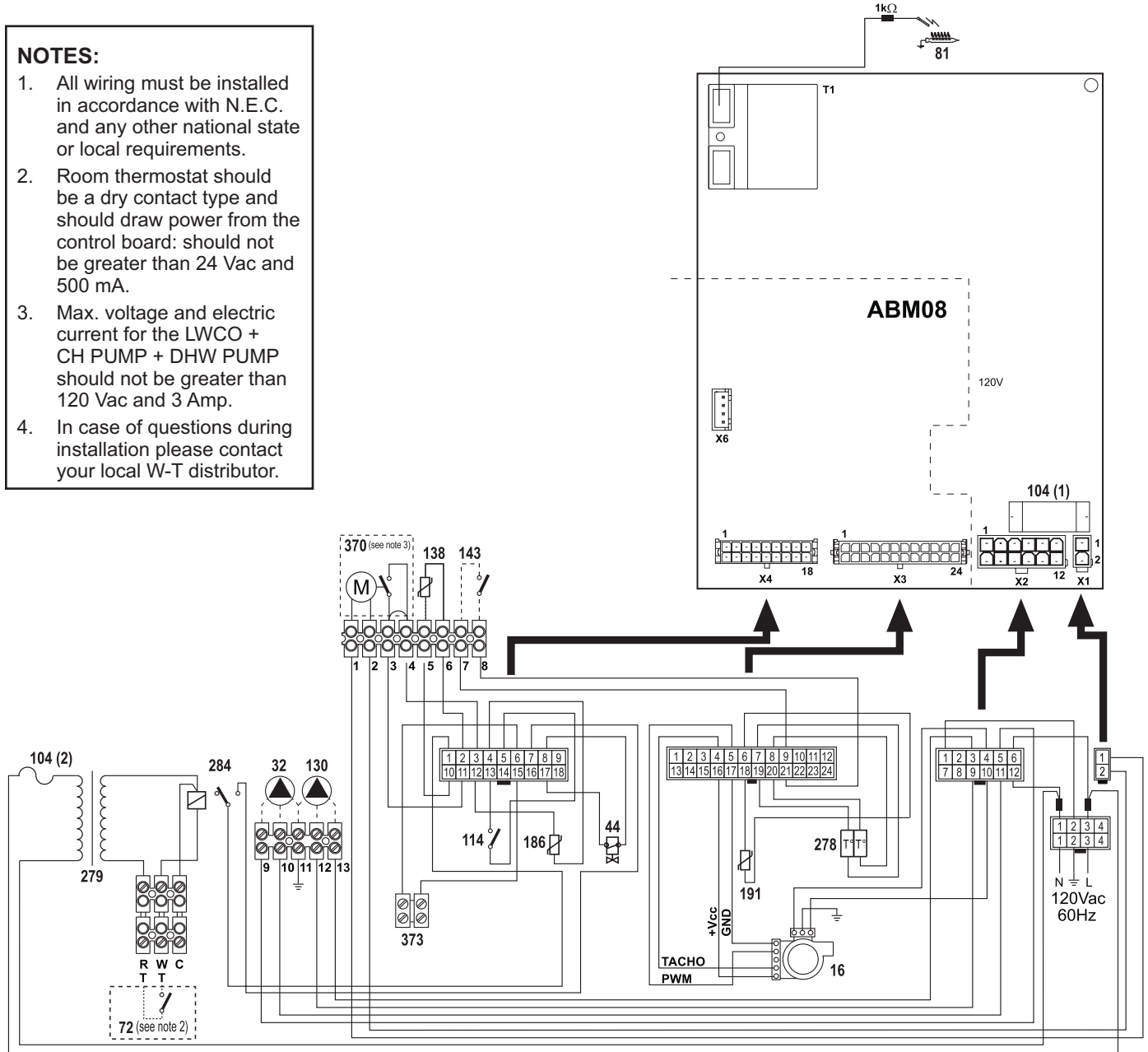
cod. 35411640 FS-E128-BDOC

23 Wiring diagram — FS-155 Heating Only Ladder

Figure 72 FreeStyle®155 Ladder Wiring Diagram

NOTES:

1. All wiring must be installed in accordance with N.E.C. and any other national state or local requirements.
2. Room thermostat should be a dry contact type and should draw power from the control board: should not be greater than 24 Vac and 500 mA.
3. Max. voltage and electric current for the LWCO + CH PUMP + DHW PUMP should not be greater than 120 Vac and 3 Amp.
4. In case of questions during installation please contact your local W-T distributor.



cod. 3541870

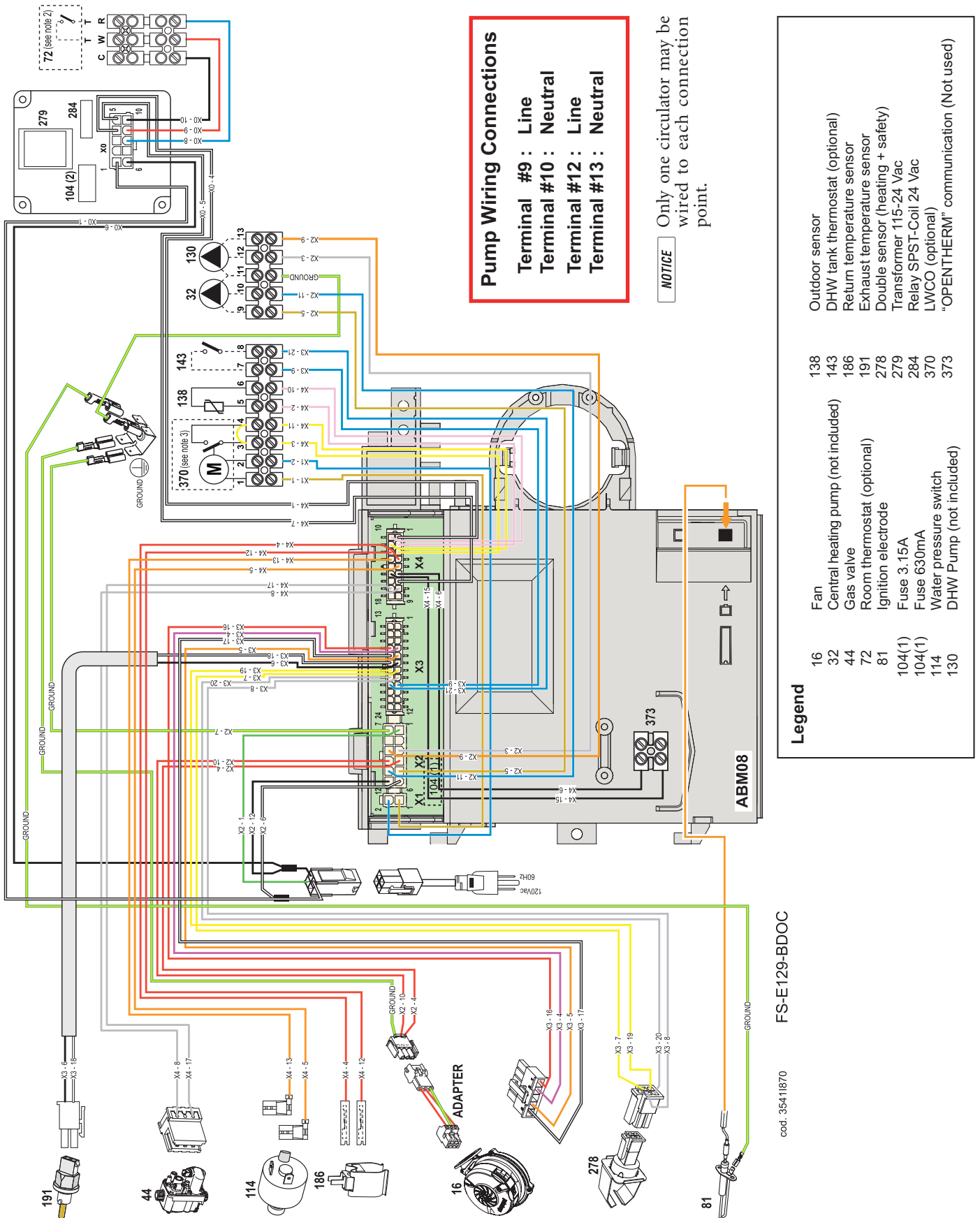
FS-E129-BDOC

Legend

16	Fan	138	Outdoor sensor
32	Central heating pump (not included)	143	DHW tank thermostat (optional)
44	Gas valve	186	Return temperature sensor
72	Room thermostat (optional)	191	Exhaust temperature sensor
81	Ignition electrode	278	Double sensor (heating + safety)
104(1)	Fuse 3.15A	279	Transformer 115-24 Vac
104(1)	Fuse 630mA	284	Relay SPST-Coil 24 Vac
114	Water pressure switch	370	LWCO (optional)
130	DHW Pump (not included)	373	"OPENTHERM" communication (Not used)

23 Wiring diagram — FS- 155 Heating Only Schematic

Figure 73 FreeStyle® 155 Heating Only Schematic Wiring Diagram



24 Controls and operation

Control Introduction

FreeStyle® boiler is a high-efficiency condensing pre-mix appliance for central heating and hot water production, running on Natural gas or Liquefied Petroleum (Propane) gas, generating extremely low emissions.

The boiler is constructed with a stainless steel heat exchanger providing effective condensation of the water vapor contained in the flue gases, permitting extremely high efficiency.

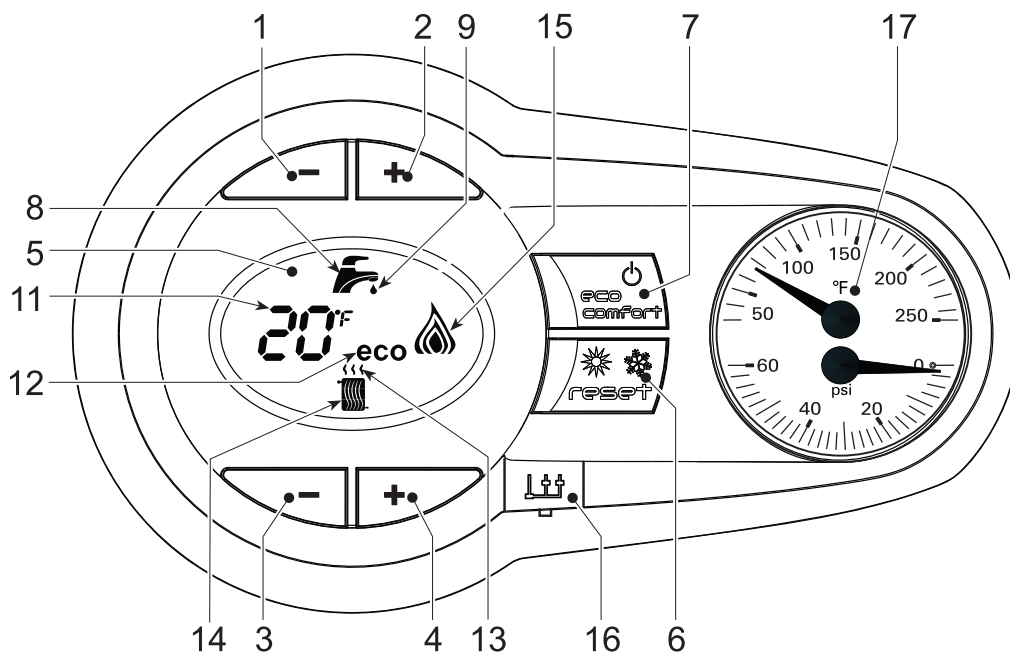
Inside the boiler there is a premix burner with a large stainless steel surface.

The boiler is sealed from the installation room: the air needed for combustion is drawn from outside. The boiler also includes a gas valve, pump, (Combi boiler), safety valve, flow sensor, (Combi boiler) dual safety and control temperature sensor, a safety thermostat and a low water pressure switch.

Thanks to the microprocessor control and adjustment system with advanced self-diagnosis, unit operation is for the most part automatic. The system heating temperature is automatically governed by the control system.

The display continuously provides information on the unit's operating status and it is easily possible to obtain and adjust temperature set-points, etc. or configure them. Any operating problems associated with the boiler are immediately signalled by the display and, if possible, corrected automatically.

Figure 74 Control panel



LEGEND for Figure 74

- | | |
|--|---|
| 1 — Domestic Hot Water temperature setpoint decreasing button | 11 — Multi-function indication (Flashing during heat exchanger protection) |
| 2 — Domestic Hot Water temperature setpoint increasing button | 12 — Economy symbol |
| 3 — Central Heating water temperature setpoint decreasing button | 13 — Central Heating mode operation |
| 4 — Central Heating water temperature setpoint increasing button | 14 — Central Heating symbol |
| 5 — LCD Display | 15 — Burner on and actual load indication (Flashing during flame current supervision) |
| 6 — Reset / OTC button | 16 — Service tool connector |
| 7 — Economy-Comfort On-Off -Power button | 17 — Temperature-Pressure gauge |
| 8 — Domestic Hot Water symbol | |
| 9 — Domestic Hot Water mode operation | |

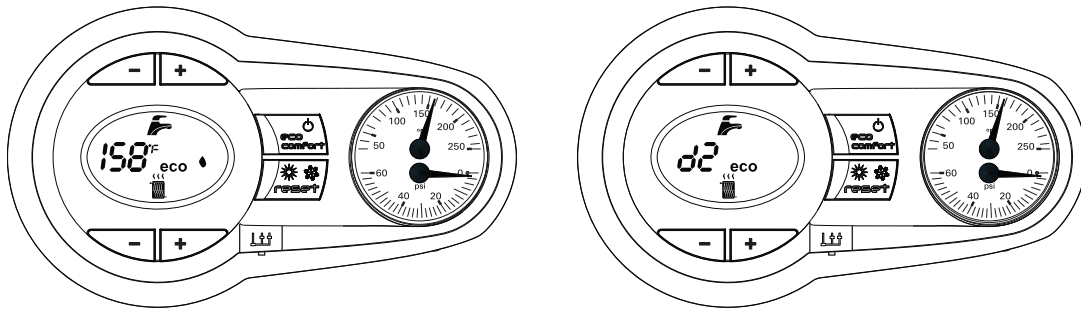
24 Controls and operation *(continued)*

Central heating operation

The Central Heating heat demand (generated by the Room Thermostat) is indicated by the flashing of the Hot Air symbol over the radiator (Items 13 and 14 - Figure 74, page 60). The display indicates the actual Central Heating water temperature (Item 11 - Figure 74, page 60) and when the required temperature is reached “d2” will be displayed.

NOTE: Heating Only boilers must be in “eco mode”.

Figure 75 Central heating mode

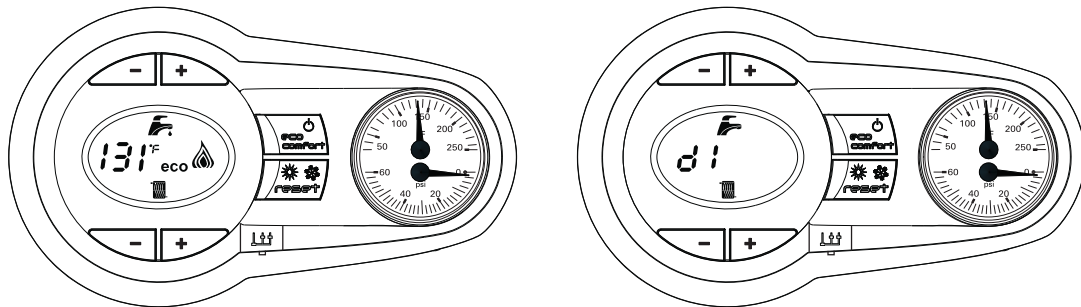


Domestic hot water operation

The Domestic Hot Water heat demand (generated by the DHW flow sensor) is indicated by the flashing of the Hot Water symbol under the tap (Items 8 and 9 - Figure 74, page 60). The display indicates the actual Domestic Hot Water temperature (Item 11 - Figure 74, page 60) and after Hot water usage “d1” will be displayed.

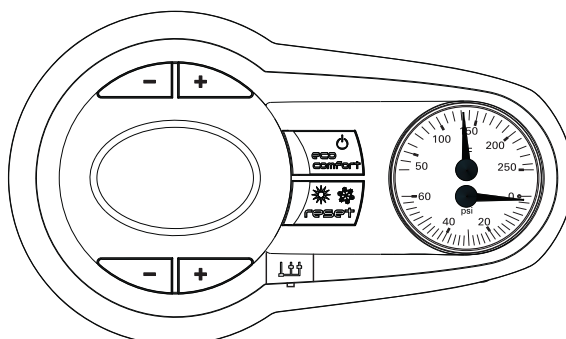
NOTE: Combi boilers must be in “comfort mode”.

Figure 76 Domestic hot water (DHW) mode



Boiler without Power

Figure 77 Boiler without main power supply

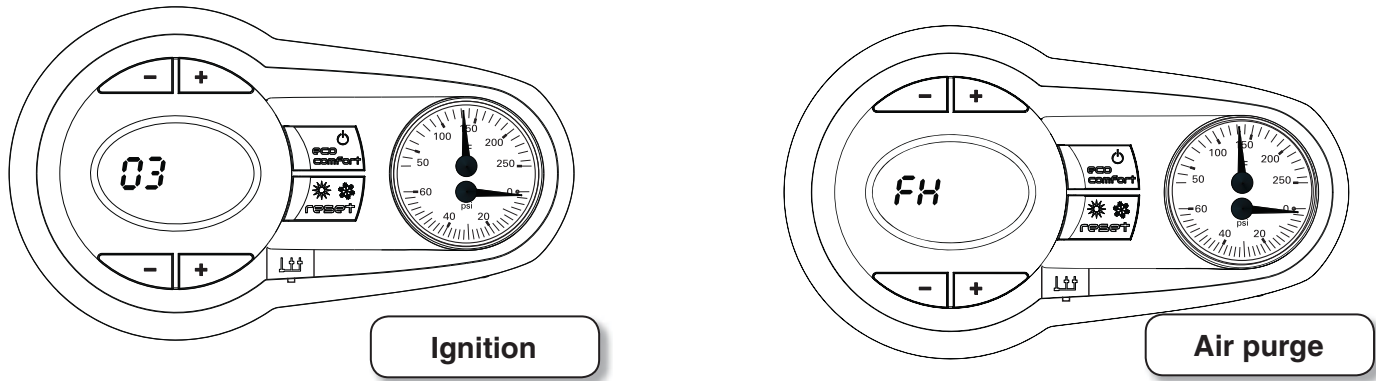


24 Controls and operation *(continued)*

Ignition operation

Ensure the power is on to the boiler

Figure 78 Ignition mode



During the first 5 seconds, the display shows the software version of the pcb.

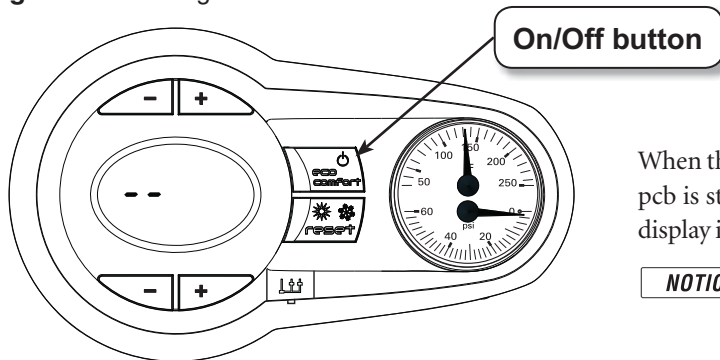
For the first 300 seconds, the display shows FH that identifies the Air purge function.

When the FH disappears, the boiler is ready to function automatically whenever the external controls are calling for heat.

Turning off

Press the on/off button (Item 7 - Figure 74, page 60) for 5 seconds.

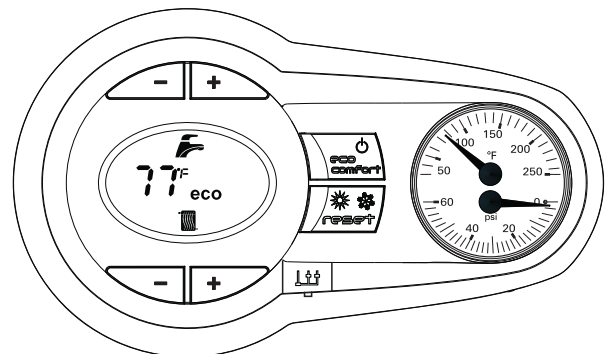
Figure 79 Turning off mode



When the boiler is turned off with “eco”/power button, the pcb is still powered, heating operation is disabled and the display is off, however the frost protection will still be active.

NOTICE To totally isolate, close the gas cock before the boiler and disconnect electricity supply.

To turn boiler on again, press the on/off button (Item 7 - Figure 74, page 60) hold for 5 seconds



The boiler is ready to function automatically whenever the external controls are calling for heat.

24 Controls and operation *(continued)*

Adjustments

Figure 80 Heating temperature settings

To set the system Heating temperature, use the CH buttons, “-” to reduce water setpoint “+” to increase water setpoint (Items 3 and 4 - Figure 74, page 60). It can be set from a minimum of 68° F to a maximum of 194° F.

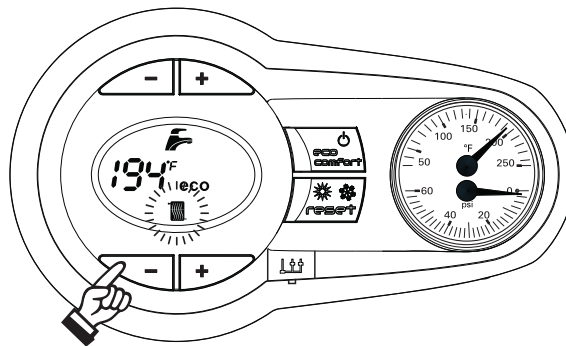
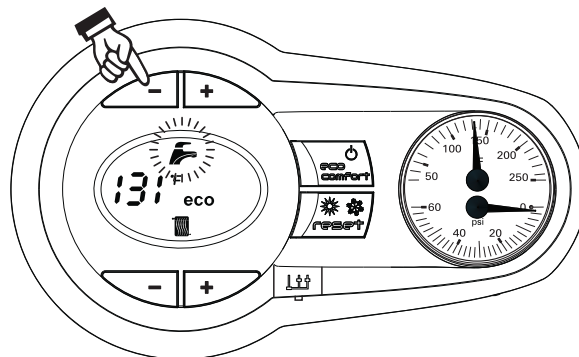


Figure 81 Domestic hot water temperature settings

To set the Domestic hot water temperature, use the DHW buttons, “-” to reduce water setpoint “+” to increase water setpoint (Items 1 and 2 - Figure 74, page 60). It can be set from a minimum of 104° F to a maximum of 131° F.



Room temperature adjustment (using a room thermostat)

- Using the room thermostat, set the temperature desired. Controlled by the room thermostat, the boiler heats the system water to the system delivery setpoint temperature. The boiler shuts down when the desired temperature in the room is reached.

Economy/Comfort selection

- The unit is equipped with a special internal device that ensures a high hot-water delivery speed and excellent user comfort. When comfort mode is active the water in the boiler is maintained at a pre-determined temperature, which means that hot water is available at the boiler outlet as soon as a tap is opened, i.e. with no waiting.

- The user can turn the device off (“eco” mode, is a “cold start” boiler) by pressing economy/comfort button (Item 7 - Figure 74, page 60).
- In “eco” mode the display shows the relevant symbol (Item 12 - Figure 74, page 60). **To turn on COMFORT mode**, press economy/comfort button (Item 7 - Figure 74, page 60), again, **the “eco” symbol will vanish from the display**.

Heating Only boiler must use Comfort mode.

24 Controls and operation *(continued)*

Adjustments

Theory of Outdoor Reset Control

One of the key points to boiler efficiency, is to match the heat generated by the boiler to the heat loss of the building to be able to obtain a given comfort level in the living space.

- You can obtain this efficiency by selecting a scale within an operating programmed range of the boiler water temperature. These scale ranges are related to the outdoor temperatures, and boiler water temperatures for the installed radiation.
- These “**Outdoor Reset Control**” curves are graphed (and programmed into the control board) by outside temperature from 68 degrees to -4 degrees F and boiler water target temperatures from 86 to 194 degrees F (see Figure 84, page 65), where the heat loss of the home, will match the gradual increase in boiler water temperature as the outside temperature drops.
- The average heat loss of a home may meet the needs (boiler water temperatures) of offset curve number 5 (Figure 86, page 65) to meet the heat loss at given outdoor temperatures.
- Another example would be a high heat loss structure, where curve number 10 would drive up the boiler water temperature with a slight drop in outdoor temperature. (from 68 degrees F outside temperature to just a drop to 50 degrees F outdoor temperature, see Figure 86, page 65)
- An example of a structure with very little heat loss, (such as a super insulated, high efficiency building) would be curve number 1, where the outdoor temperatures continue to drop, and the boiler water temperatures are in the low range from 86 degrees to 104 degrees F.

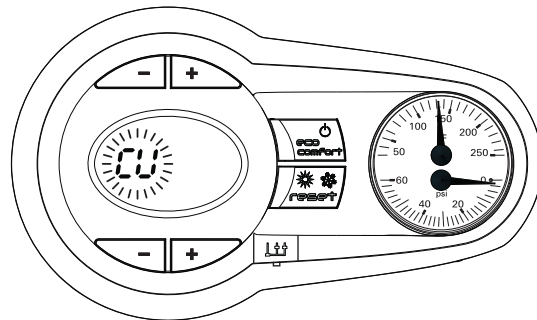
Outdoor Reset Control (optional on the Combi)

- When the external outdoor sensor is attached to the boiler, the system can work in Outside Temperature Compensation mode. In OTC mode the temperature of the heating system is controlled according to the external climate conditions, this will insure a high degree of comfort and energy saving all year round.
- By using the CH buttons (Items 3 and 4 - Figure 74, page 60) it is possible to set the maximum system water flow temperature for the installation.

OTC setting

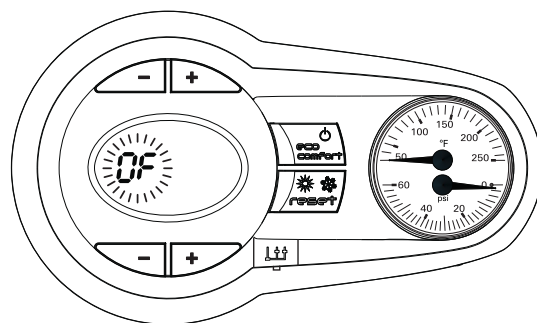
- To enter the OTC- reset mode, press OTC button (Item 6 - Figure 74, page 60) for 5 seconds.
- The display shows “CU” flashing Figure 82; to set Curve, use the DHW buttons (Items 1 and 2 - Figure 74, page 60). It can be varied from 1 to 10, in accordance with the chart Figure 84, page 65. “O” means no OTC mode.
- By pressing the CH push buttons (Items 3 and 4 - Figure 74, page 60), the display shows “OF” flashing Figure 83; to set Offset, use the DHW push buttons (Items 1 and 2

Figure 82 OTC settings



- Figure 74, page 60). It can be varied from 68 to 104, in accordance with the chart Figure 85 or Figure 86.
- 4. To exit the OTC mode, press OTC button (Item 6 - Figure 74, page 60) for 5 seconds.

Figure 83 OTC “OFFSET” settings



In the case of an outdoor sensor failure, the control will continue to operate the boiler, but without the use of the Compensation Curves, and an error message will flash on the display (Fault 39-please see Figure 110, page 85).

Upon replacement of the defective sensor the boiler will resume the use of Compensation Curves.

OTC Exempt mode

By pressing the DHW+ and ECO buttons together for 10 seconds, it is possible to enter the OTC Exempt menu. The display starts showing the value of the parameter OTC Exempt (See parameter Num. 163, page 97) flashing. By means of the CH-push button it is possible to change value. By pressing DHW+ and ECO buttons together for 10 seconds, it is possible to leave the OTC Exempt Menu. If no action has been taken, the control automatically leaves this mode after 2 minutes.

- 0 = installation non exempt from outside sensor connection;
- 1 = installation exempt from outside sensor connection;

Compensation curves

Curve numbers below refer to Figures 84, 85, & 86, page 65.

- Curve number 1 is for a high efficiency home with very **low** heat losses.
- Curve number 5 is for an average home heat losses.
- Curve number 10 is for a home with **high** heat losses.

24 Controls and operation

(continued)

Figure 84 Compensation curves

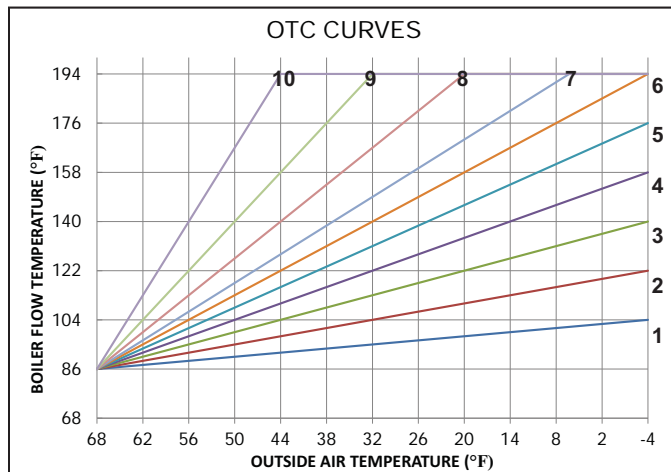


Figure 85 Compensation parallel offset curves
Typical low temperature radiant application such as in-floor tubing.

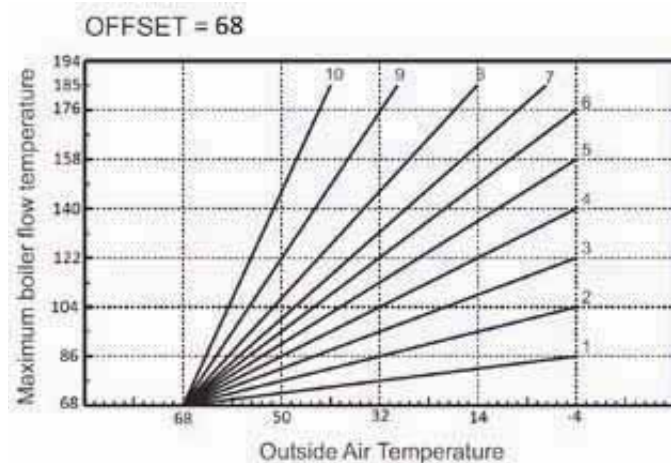
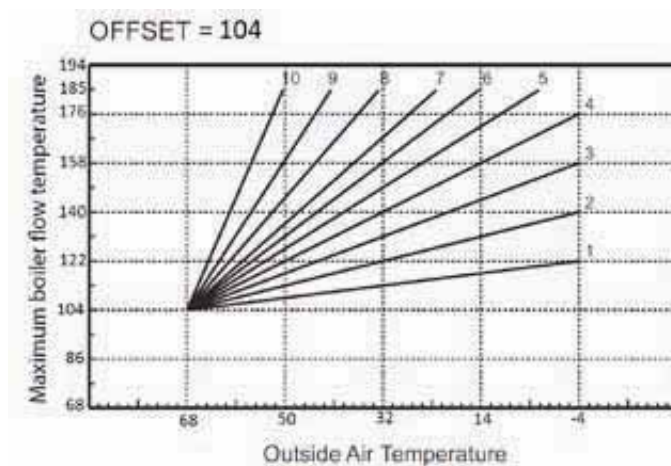


Figure 86 Compensation parallel offset curves
Typical fin tube /baseboard radiation.



25 DHW Settings (Combi Only)

DHW SETTINGS

1. The DHW SETTINGS menus are for setting control operation during DHW operation. The settings apply ONLY to DHW Zone.
2. If DHW is used, the settings for control operation during DHW calls for heat are set under the DHW SETTINGS menus (Figure 76, page 61).

DHW TEMPERATURES

NOTICE

DHW priority — The FreeStyle® control gives priority to DHW operation. During DHW call for heat, the central heating zone output is disabled. This continues until the DHW call ends or the DHW MAX ON TIME has elapsed which is 30 minutes.

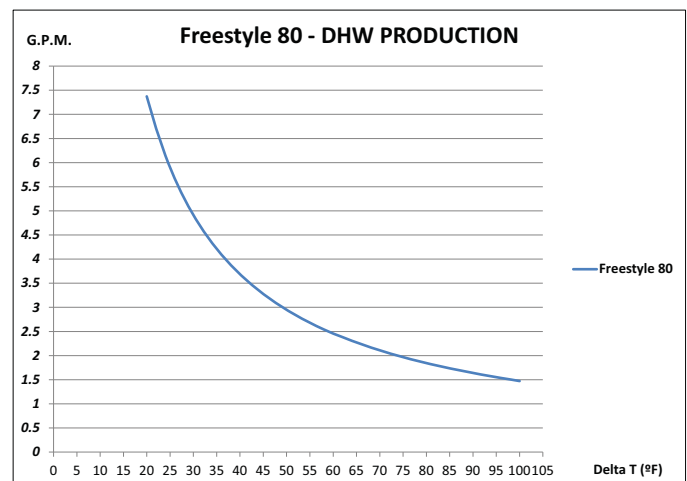
BOILER SUPPLY

1. The FreeStyle® control will regulate boiler firing to provide outlet water at this temperature.
2. For most DHW applications, set this to 190°F. A lower supply temperature can be used, but will reduce the indirect water heater heating capacity.

Figure 87 DHW SETTINGS menu (see below for setting values and descriptions)

Rated Heat Input	DHW production rate				
	[MBH]	[GPM with ΔT =30°F]	[GPM with ΔT =50°F]	[GPM with ΔT =70°F]	[GPM with ΔT =90°F]
FS-80	4.7	2.8	2.0	1.6	
FS-120	7.2	4.4	3.2	2.4	
FS-155	9.2	5.6	4.0	3.1	

Figure 88 DHW curve - FreeStyle 80



25 DHW Settings (Combi Only)

(continued)

Figure 89 DHW curve - FreeStyle 120

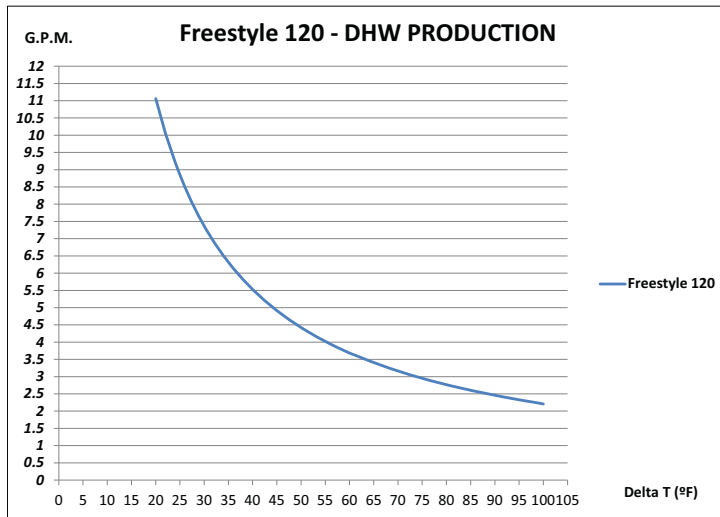
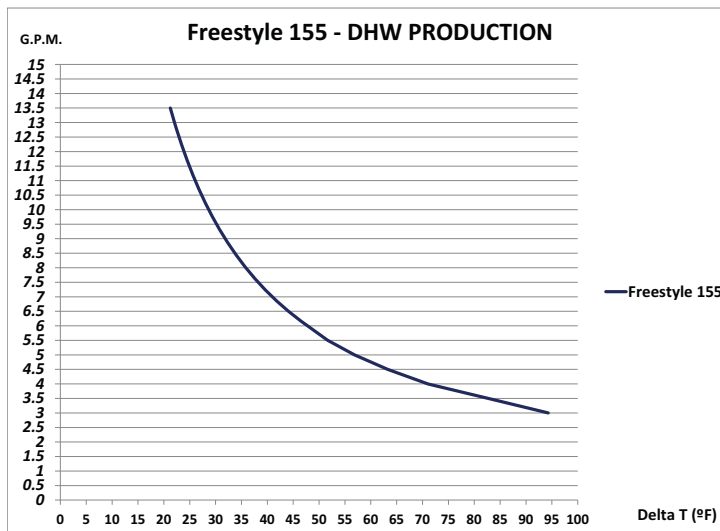


Figure 90 DHW curve - FreeStyle 155



26 High Altitude

HIGH ALTITUDE BOILER ADJUSTMENT (above 4,500' installations)

1. Press DHW- and DHW+ buttons together for 10 seconds to enter the parameter setup menu. The standard values for parameter “b04”, “b05” and “b06”, are shown in Figure 92.
2. Roll down the menu by pressing the CH button until the parameter “b04” is on the screen.
3. Set parameter “b04” to parameter in Figure 91.
4. Repeat steps 2 and 3 above to also adjust parameter “b05” and “b06”, according to Figure 91.
5. Press DHW- and DHW+ buttons together for 10 seconds to leave the menu. The values are automatically saved.

Figure 91 HIGH Altitude Fan Speeds

Model	High Altitude			
	Fan Speed Hz			
	Low Fire (b06)	Ignition (Can't Change - Needs PC)	High Fire In CH Mode (b05)	High Fire In DHW Mode (b04)
FS-80-N	48	80%	160	160
FS-80-LP	48	80%	150	150
FS-120-N	54	60%	195	195
FS-120-LP	54	60%	190	190
FS-155-N	53	60%	210	210
FS-155-LP	54	60%	205	205

Figure 92 STANDARD Altitude Fan Speeds
(for below 4,500' installations)

Model	Standard Altitude			
	Fan Speed Hz			
	Low Fire (b06)	Ignition (Can't Change - Needs PC)	High Fire In CH Mode (b05)	High Fire In DHW Mode (b04)
FS-80-N	40	80%	155	155
FS-80-LP	40	80%	145	145
FS-120-N	40	60%	200	200
FS-120-LP	40	60%	185	185
FS-155-N	39	60%	205	205
FS-155-LP	40	60%	200	200

NOTICE

In USA Input rates are derated 4% for each 1000 ft. above sea level, beyond 2000 ft. in accordance with National Fuel Gas Code, ANSI Z223.1/NFPA 54

WARNING

For elevations above 10,000 feet, please contact Williamson-Thermoflo at 800-736-2378.

CIRCULATOR EXERCISING and FREEZE PROTECTION

CIRCULATOR EXERCISING

1. The FreeStyle® control will automatically start the circulator output and run for 10 seconds for each 72-hour period of inactivity.

FREEZE PROTECTION

1. This function automatically fires the boiler and starts the HEAT circulator when the heat exchanger sensor detects a temperature less than 40 °F. The circulator turns off when the temperature rises above 45 °F.

27 Startup

Clean system to remove sediment

1. You must thoroughly flush the system (without boiler connected) to remove sediment. The high-efficiency heat exchanger can be damaged by buildup or corrosion due to sediment.

▲WARNING If the system needs to be cleaned, use only Sentinel X400 cleaner, available from Williamson-Thermoflo. See Figure 153, page 113 for information. Follow instructions supplied with the X400 cleaner and cleaning instructions on page 107. For zoned systems, flush each zone separately through a purge valve. (If purge valves and isolation valves are not already installed, install them to properly clean the system).

2. Flush system until water runs clean and you are sure piping is free of sediment.

▲WARNING Do not use petroleum-based cleaning or sealing compounds in boiler system. Damage to elastomer seals and gaskets in system could occur, resulting in substantial property damage. Before filling the boiler and system with water, verify the following. Boiler corrosion can occur. Failure to comply could result in boiler failure or unreliable operation.

Water chemistry

Water pH between 7.0 and 8.5

1. Maintain boiler water pH between 7.0 and 8.5. Check with litmus paper or have chemically analyzed by water treatment company.
2. If pH differs from above, consult local water treatment company for treatment needed.

Hardness less than 7 grains

1. Consult local water treatment companies for unusually hard water areas (above 7 grains hardness).

Chloride concentration must be LESS THAN 50 ppm

1. Filling with chlorinated fresh water should be acceptable since drinking water chloride levels are typically less than 5 ppm.
2. Do not use the boiler to directly heat swimming pool or spa water.
3. Do not fill boiler or operate with water containing chloride in excess of 50 ppm.

▲WARNING Verify that the water chemistry meets the limitations and requirements of all other equipment in the system.

Antifreeze

1. Use only antifreeze listed by Williamson-Thermoflo as suitable for use with FreeStyle® Gas Boilers. See Figure 153, page 113 for information.
2. See Replacement parts at the end of this manual for Williamson-Thermoflo part numbers to obtain antifreeze through a Williamson-Thermoflo distributor.

Use the correct amount of antifreeze

1. Determine the freezing temperature needed (to protect against lowest likely temperature the system water will encounter).
2. Find the antifreeze concentration by volume needed for this temperature from the antifreeze manufacturer's data on the antifreeze container.
3. Add up the volume (gallons) of all system piping and components, including the expansion tank and boiler.
 - a. Boiler water content is listed in Figure 166, page 126.
 - b. Remember to include expansion tank water content.
4. Multiply this volume by the (percent) antifreeze needed to find the number of gallons of antifreeze to add.

Fill and test water system

1. Fill system only after ensuring the water meets the requirements of this manual.
2. Close manual and automatic air vents and boiler drain valve.
3. Fill to correct system pressure. Correct pressure will vary with each application.
 - a. Typical cold water fill pressure for a residential system is 12 psi.

NOTICE Boiler water pressure switch is set for 9 psi (± 2) minimum pressure. A low water pressure will give "F37" fault code.

- b. Pressure will rise when boiler is turned on and system water temperature increases. Operating pressure must never exceed 25 PSIG.
4. At initial fill and during boiler startup and testing, check system thoroughly for any leaks. Repair all leaks before proceeding further.

▲WARNING Eliminate all system leaks. Continual fresh make-up water will reduce boiler life. Minerals can build up in the heat exchanger, reducing heat transfer, overheating heat exchanger, and causing heat exchanger failure.

Purge air from water system

1. Connect a hose to the drain valve (see drain valves, item 10, in piping diagrams beginning on page 11). Route hose to an area where water can drain and be seen.
2. Close the boiler or system isolation valve between the drain valve and fill connection to the system.
3. Close zone isolation valves.
4. Open quick-fill valve on cold water make-up line.
5. Open drain valve.
6. One zone at a time, open the isolation valves. Allow water to run through the zone, pushing out the air. Run until no noticeable air flow is present. Close the zone isolation valves and proceed with the next zone. Follow this procedure until all zones are purged. Follow the same procedure to purge air from the boiler and its internal piping.
7. Close the quick-fill water valve and drain valve and remove the hose. Open all isolation valves. Watch that system pressure rises to correct cold-fill pressure.

27 Startup *(continued)*

Freeze protection (if used)

▲WARNING Follow these guidelines to prevent possibility of severe personal injury, death or substantial property damage:

Use only the products listed by Williamson-Thermoflo for use with this boiler. See page 113 for information.

Thoroughly flush any system that has used glycol before installing the new FreeStyle® boiler.

Review the material safety data sheets (MSDS) are available online. The MSDS contains information on potential hazards and first aid procedures for exposure or ingestion.

Check antifreeze inhibitor level at least annually. Glycol concentration and inhibitor levels may change over time. Add antifreeze to increase concentration if necessary. Add inhibitor as needed to bring to acceptable level, using inhibitor test kit to verify.

In addition to antifreeze and inhibitor, use and maintain minimum level of Sentinel X100 inhibitor as directed on this page.

If using freeze protection fluid with automatic fill, **install a water meter to monitor water make-up.** Freeze protection fluid may leak before the water begins to leak, causing concentration to drop, reducing the freeze protection level.

DO NOT exceed 50% antifreeze by volume. Antifreeze moves more sluggishly than water and can interfere with heat transfer. At antifreeze concentrations higher than 50%, sludge can develop in the boiler, potentially causing damage to the heat exchanger.

Clean the system before filling. Always drain and flush the system thoroughly before filling with antifreeze. Sludge, iron oxide deposits and other sediment in the system inhibit flow and can cause rapid breakdown of inhibitors.

Use only antifreeze recommended by Williamson-Thermoflo.

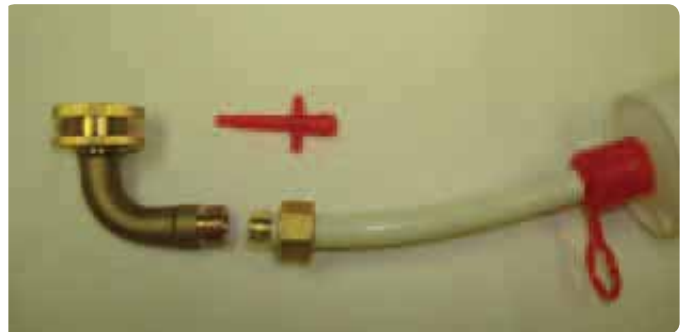
NOTICE Williamson-Thermoflo provides information for application of the antifreeze products listed in this document only for use in boilers. Do not apply these products or instructions for other applications. Local codes may require a backflow preventer or actual disconnection from city water supply.

8. After the system has operated for a while, eliminate any residual air by using the manual air vents located throughout the system.
9. If purge valves are not installed in system, open manual air vents in system one at a time, beginning with lowest floor. Close vent when water squirts out. Repeat with remaining vents.
10. Open automatic air vent (diaphragm-type or bladder-type expansion tank systems only) one turn.
11. Starting on the lowest floor, open air vents one at a time until water squirts out.
12. Repeat with remaining vents.
13. Refill to correct pressure.

Use of X100 inhibitor is REQUIRED

1. The FreeStyle® boiler is shipped with Sentinel X100 inhibitor and Sentinel X100 Quick Test Kit. See Repair Parts Figure 153, page 113 for re-ordering information.
2. After filling the system as directed in this manual, and the air purge has been completed, release the system water pressure to 0 psi. Drain a small amount of water out of a convenient boiler drain to insure the system water pressure is at 0 psi. Use a (field supplied) Dishwasher elbow / hose 3/4 to 3/8 compression adapter (See Figure 93 below) to the white Sentinel hose, and screw it to the tube of Sentinel X100. Insert it into your caulk gun, and fit the washing machine hose adapter to a boiler drain connection. Open the drain, and inject the complete tube of X100 to the system. Close the drain valve, and remove the injection fitting.

Figure 93 Hardware fittings to add Sentinel to boiler



3. Fill system water to required pressure, and start a heating zone to circulate system water. Allow time for the water to circulate and mix. Then check the inhibitor level with supplied test kit. Add additional inhibitor if necessary.

Check/verify water chemistry

1. The system may have residual substances that could affect water chemistry.
2. After the system has been filled and leak tested, verify water pH and chloride concentrations are acceptable.
3. Verify antifreeze concentration, if used.
4. Follow the instructions on the Sentinel test kit to sample the system water and verify inhibitor concentration.

28 Startup — final checks

⚠️WARNING Check for gas leaks

Before starting the boiler, and during initial operation, use a leak detector or smell near the floor and around the boiler for gas odorant or any unusual odor. Remove boiler jacket door and smell the interior of the boiler jacket. **Do not proceed with startup if there is any indication of a gas leak. Repair any leak at once.**

DO NOT adjust or attempt to measure gas valve outlet pressure. The gas valve is factory-set for the correct outlet pressure. This setting is suitable for natural gas and propane, requiring no field adjustment. Attempting to alter or measure the gas valve outlet pressure could result in damage to the valve, causing potential severe personal injury, death or substantial property damage.

Propane boilers only — Your propane supplier mixes an odorant with the propane to make its presence detectable. In some instances, the odorant can fade, and the gas may no longer have an odor. Before startup (and periodically thereafter), have the propane supplier verify the correct odorant level in the gas.

Check inhibitor concentration annually

1. Test the pH of a sample of system water at least annually. The pH of the water mixture must be between 7.0 and 8.5. (Or use the Sentinel inhibitor test kit to check concentration.)
2. If pH is outside this range (or inhibitor test kit indicates low level), the inhibitor level may not be sufficient to prevent corrosion.
3. Test antifreeze concentration.

⚠️WARNING Test antifreeze concentration at least annually. If concentration is low, add antifreeze or drain system and refill with correct mixture.

4. Follow instructions on antifreeze container to determine the amount of antifreeze needed. **DO NOT** exceed 50% by volume concentration of antifreeze.

Check inhibitor level after adjustments are made.

Check thermostat circuits

1. Disconnect wires connected to the **DHW and HEAT** thermostat terminals (see Field wiring, beginning on page 50 for low voltage terminal locations and application information). Mark the wires before removing to avoid wiring errors when re-connecting them.
2. Connect a voltmeter across each pair of incoming wires. Close each thermostat, zone valve and relay in the external circuits one at a time and check the voltmeter reading across the incoming wires.
3. **There should NEVER be a voltage reading.**

4. If a voltage does occur under any condition, check and correct the external wiring.

⚠️WARNING **DO NOT connect the FreeStyle® thermostat terminals to 3-wire zone valves.** This could cause control damage.

5. Once the external thermostat circuit wiring is checked and corrected if necessary, reconnect the external thermostat circuit wires.

Inspect/fill condensate system

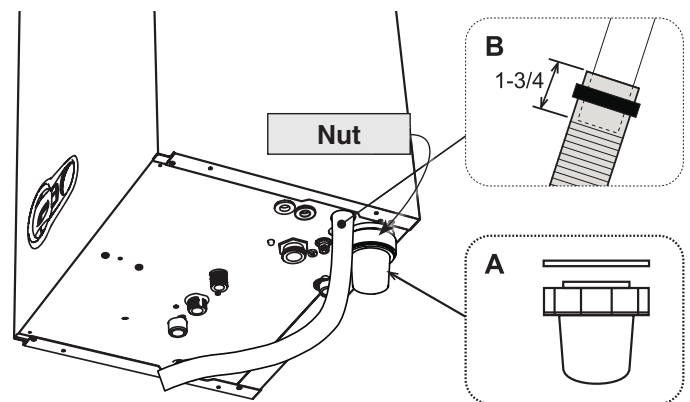
Inspect/check condensate lines and fittings

1. Inspect the condensate drain line, condensate PVC fittings and condensate trap. (See page 47 for component locations.)

Fill condensate trap with water

1. Loosen the nut that secures the condensate trap body to the boiler condensate connection (see Figure 94). Pull the trap down to disengage from heat exchanger. Pull the trap body forward enough to allow pouring water into the top of the trap.
2. Fill the trap with fresh water until water begins to run into the condensate drain tube.
3. Reattach the trap body by sliding onto the boiler condensate outlet, then retightening the trap body nut.

Figure 94 Disconnect condensate trap assembly to fill trap body with water



⚠️WARNING The condensate trap must be filled with water during all times of boiler operation to avoid flue gas emission from the condensate drain line. Failure to fill the trap could result in severe personal injury or death.

⚠️WARNING If it is suspected that the condensate drain connection is or was blocked, then boiler components like the gas valve, blower venturi, igniter and heat exchanger need to be inspected. Check for damages occurring from water accumulation in this cabinet. Any damaged components need to be replaced. Failure to replace water damaged components could result in severe personal injury or death.

28 Startup — final checks *(continued)*

Final checks before lighting the boiler

- Open any on-off valves between boiler and the systems.
- Verify that there are no leaks of the gas system.
- Verify that the boiler and system are full of water and all system components are correctly set for operation.
- Verify that condensate trap drain line is filled with water.
- Verify that there are no leaks in the system, DHW piping, connections or boiler.
- Verify electrical connections are correct and securely attached.
- Inspect vent piping and air piping for signs of deterioration from corrosion, physical damage or sagging. Verify air piping and vent piping are intact and correctly installed per this manual.
- Read the instructions to adjust and set up the FreeStyle® control.
- Verify that the boiler model is set correctly in the FreeStyle® control, and that it displays correctly.

To start the boiler

NOTICE The combustion for this boiler has been checked, adjusted and preset at the factory for operation for Natural Gas.

Having checked:

- That the boiler has been installed in accordance with these instructions.
- The integrity of the flue system and the flue seals.
- The integrity of the boiler combustion circuit and the relevant seals.

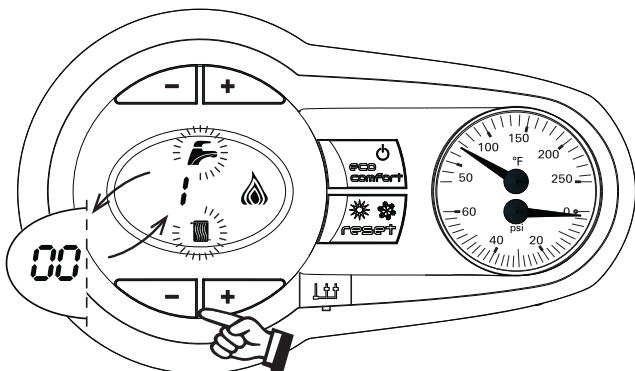
1. Apply power to the boiler.
2. Follow the Operating Instructions, Figure 96, page 71.

Test Mode Operation

Proceed to put the boiler into operation as follows:

1. To operate the boiler in test mode, press the CH “-” and “+” keys together for 5 seconds (See below) to activate the “TEST” mode.
2. The boiler lights at the maximum heating 100% rate displayed on the LCD display.

Figure 95 Control in Test Mode



3. The high fire (large) flame symbol will be displayed once the boiler has lit.
4. Use DHW “-” button to drop firing rate to low fire.
5. To exit the “TEST” mode, press the CH keys (Items 3 and 4 Figure 74, page 60) together for 5 seconds, or leave the boiler to automatically switch off after 15 minutes or stopping DHW flow.
6. This TEST procedure is used to check/adjust combustion CO and CO₂ per specifications Figure 98, page 73 and Figure 101, page 74.

If boiler does not start correctly

1. Check for loose connections, blown fuse or is boiler Not plugged in?
2. Are external limit controls (if used) open? Is boiler water temperature above 200°F?
3. Are thermostats set below room temperature?
4. Is gas turned on at meter and boiler?
5. Is incoming gas pressure less than the minimum values given on page 16?
6. Are FreeStyle® control settings correct for the application?
7. If none of the above corrects the problem, refer to Troubleshooting, beginning on page 81.

Check system and boiler

Check water piping

1. Check system piping for leaks. If found, shut down boiler and repair immediately. (See WARNING on page 67 regarding failure to repair leaks.)
2. Vent any remaining air from system using manual vents. Air in the system will interfere with circulation and cause heat distribution problems and noise.

Check vent piping and air piping

1. Check for gas-tight seal at every connection and seam of air piping and vent piping.

WARNING Venting system must be sealed gas-tight to prevent flue gas spillage and carbon monoxide emissions which will result in severe personal injury or death.

Check gas piping

1. Check around the boiler and inside the boiler jacket for gas odor following the instructions in “Warning” on page 48 of this manual.

WARNING If you discover evidence of any gas leak, shut down the boiler at once. Find the leak source with bubble test and repair immediately. Do not start boiler again until corrected. Failure to comply could result in severe personal injury, death or substantial property damage.

CONTINUED AFTER NEXT PAGE

28 Startup — final checks *(continued)*

Figure 96 Operating instructions (WARNING — Verify that the FreeStyle® control is set for the correct boiler model before proceeding.)

FOR YOUR SAFETY — READ BEFORE OPERATING

⚠ WARNING

If you do not follow these instructions exactly, a fire or explosion may result causing property damage, personal injury or loss of life.

- | | |
|---|---|
| <p>A. This appliance does not have a pilot. It is equipped with an ignition device which automatically lights the burner. Do not try to light the burner by hand.</p> | <p>C. Use only your hand to turn the gas control knob. Never use tools. If the knob will not turn by hand, don't try to repair it, call a qualified service technician. Force or attempted repair may result in a fire or explosion.</p> |
| <p>B. Before OPERATING, smell all around the appliance area for gas. Be sure to smell next to the floor because some gas is heavier than air and will settle on the floor. See below.</p> | <p>D. Do not use this appliance if any part has been under water. Immediately call a qualified service technician to inspect the appliance and to replace any part of the control system and any gas control, which has been under water.</p> |

WHAT TO DO IF YOU SMELL GAS

- Do not try to light any appliance.
- Do not touch any electric switch; do not use any phone in your building.
- Immediately call your gas supplier from a neighbor's phone. Follow the gas supplier's instructions.
- If you cannot reach your gas supplier, call the fire department.

OPERATING INSTRUCTIONS

1. **STOP!** Read the safety information above on this label. This appliance is equipped with an ignition device which automatically lights the burner. Do not try to light the burner by hand.
2. Set room thermostat(s) to lowest setting.
3. Turn OFF all electrical power to the appliance.
4. Locate boiler manual gas valve (in the gas piping below the boiler).
5. Turn boiler manual gas valve knob counterclockwise ↺ to OPEN gas supply.
6. Wait five (5) minutes to clear out any gas. Then smell for gas, including near the floor.
7. If you smell gas, **STOP!** Turn the boiler manual gas valve to OFF. Then follow WHAT TO DO IF YOU SMELL GAS, above. If you don't smell gas, go to step 8, below.
8. Turn ON all electrical power to the appliance.
9. Set thermostat(s) to desired setting.
10. The boiler display will show symbols and/or text describing the status of the boiler as it proceeds through its operating sequence.
11. If the appliance will not operate when there is a call for heat and piping is not hot, follow the instructions "To Turn Off Gas To Appliance" below and call your service technician or gas supplier.

Gas valve CLOSED



↺ to OPEN

Gas valve OPEN



↻ to CLOSE

TO TURN OFF GAS TO THE APPLIANCE

1. Set room thermostats to lowest setting.
2. Turn OFF all electrical power to the appliance.
3. Turn boiler manual gas valve knob clockwise ↻ to close gas supply.



FS-E021-B (0514)

28 Startup — final checks *(continued)*

□ Propane boilers — verify conversion

1. Verify boiler has been converted for propane. See page 12 for FreeStyle® 80, 120 or 155.

▲WARNING **DO NOT attempt to measure gas valve outlet pressure**

DO NOT adjust or attempt to measure gas valve outlet pressure. The gas valve is factory-set for the correct outlet pressure. This setting is suitable for natural gas and propane, requiring no field adjustment.

Attempting to alter or measure the gas valve outlet pressure could result in damage to the valve, causing potential severe personal injury, death or substantial property damage.

FreeStyle® boilers are shipped ready to fire natural gas ONLY.

Failure to comply could result in severe personal injury, death or substantial property damage.

□ Check flame & combustion with instruments

1. Enter into the “TEST” Mode to check combustion on High Fire and Low Fire.
2. To operate the boiler in test mode, press the CH “-” and “+” keys together for 5 seconds (See Figure 95, page 70) to activate the “TEST” mode.
3. The boiler lights at the maximum heating 100% rate displayed on the LCD display.
4. The high fire (large) flame symbol will be displayed once the boiler has lit.
5. Use DHW “_” button to drop firing rate to low fire.
6. To exit the “TEST” mode, press the CH keys (Items 3 and 4 Figure 74, page 60) together for 5 seconds, or leave the boiler to automatically switch off after 15 minutes or stopping DHW flow.
7. This TEST procedure is used to check/adjust combustion CO and CO₂ per specifications Figure 98, page 73 and Figure 101, page 74.
8. **Insert combustion analyzer probe** — Remove the flue access fittings/turn to remove (see Figure 40, page 33) from the flue pipe and insert a combustion test probe.
9. Test for CO₂ (or O₂) and for CO. The CO₂ values must comply with Figure 98 or Figure 101, page 73. If results are acceptable, proceed to step 7. **IF NOT**, follow the instructions under “Throttle Screw Adjustment” on page 73 to set the throttle screw position. See **WARNING** below.
10. Measure natural gas input for High and Low Fire:
 - a. Operate boiler 10 minutes. Turn off other appliances.
 - b. At natural gas meter, measure time (in seconds) required to use one cubic foot of gas.

▲WARNING

If combustion at either high or low fire is outside the range given in Figure 98, page 73 or Figure 101, page 74, follow the procedure given on below, “Setting the Air/Gas Ratio Valve” for adjusting the throttle screw on the gas valve. If throttle screw adjustment does not correct the problem, then shut down the boiler and contact your local Williamson-Thermoflo representative. Throttle screw adjustment must be done only by a qualified technician, using calibrated test instruments. Failure to comply could result in severe personal injury, death or substantial property damage.

- c. Calculate gas input:

$$\frac{3600 \times 1000}{\text{number of seconds from step b}} = \text{Btuh}$$

- d. Btuh calculated should approximate input rating on boiler rating label.

11. Use the FreeStyle® control display to navigate to Manual Test mode (see Figure 95, page 70) and force the firing rate to LOW (low fire). Push DHW “-” button only to drop to low fire.
12. Look at the flame through the flame inspection window. The low fire flame should be stable and evenly distributed over burner surface with a uniform orange color.
13. If combustion testing in low fire meets the specification range - Exit “TEST” Mode by pressing the CH “+” and “-” keys together for 5 seconds.
14. Reinstall the flue access fittings, (see Figure 40, page 33) used for combustion analyzer probe and lock it in closed position.

▲WARNING

You must reinstall the flue access fittings to the flue adapters, to prevent flue gas spillage from the vent adapter test ports. Failure to comply could result in severe personal injury, death or substantial property damage.

28 Startup — final checks *(continued)*

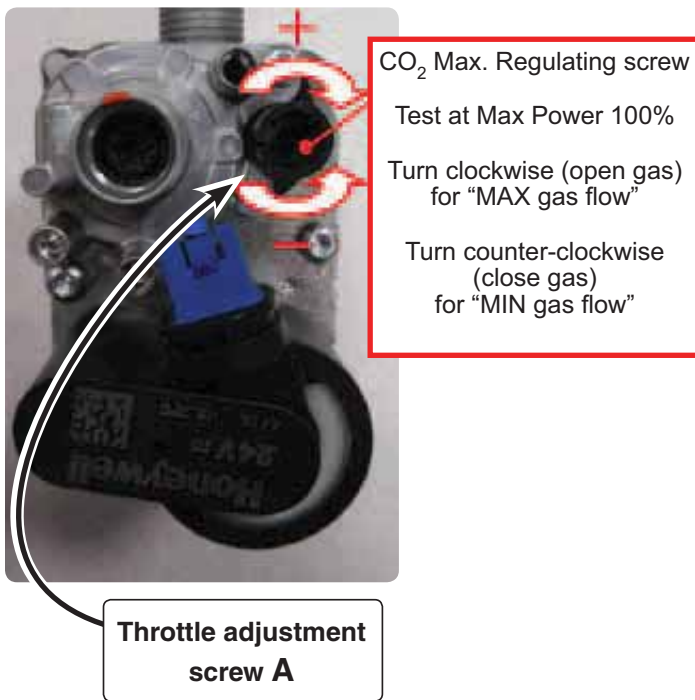
Setting the Air/Gas Ratio valve

There are two adjustments possible on the air/gas ratio valve, the throttle setting at Maximum rate and the offset setting at Minimum rate. If either setting is adjusted the combustion values must be rechecked at both rates.

At Maximum Rate:

1. Adjust the boiler to maximum rate in Figure 95, page 70, Test Mode.
2. Wait 10 minutes to allow the boiler to stabilize.
3. Now adjust the Throttle setting (Figure 97 - screw A) until the CO₂ is at the correct SETTING LEVEL (see Figure 98), below confirm that the CO/CO₂ ratio is within limits (clockwise to increase gas).

Figure 97 Throttle adjustment screw — (ONLY for use by a qualified technician, using calibrated combustion test instruments).



NOTICE

Using a combustion analyzer check the CO₂ values at low and high fire. It should be within values from the table in Figure 98. The difference of CO₂ from high fire to low fire should NEVER be below 0.2% or above 1%.

WARNING

DO NOT attempt to adjust the throttle screw unless by a qualified technician, and with the use of calibrated combustion test instruments. Adjust the throttle screw only as needed to meet the combustion values given in Figures 98 and 101, page 74.

CAUTION

Adjust in steps of no more than 1/8 of a turn and wait 1 minute after each adjustment to allow the setting to stabilise. Turning the screw too far will cause the adjustment to reverse behavior.

4. In the event that the CO₂ setting level with an acceptable CO/CO₂ ratio cannot be obtained please contact your Williamson-Thermoflo representative.
5. Should you require any assistance during the set up procedure contact your Williamson-Thermoflo representative if the problem cannot be addressed with the information provided in this manual.
6. Remove T-40 cap, see Figure 99, below, for Offset screw adjustment.

Figure 99 T-40 cap removed for adjustment



Figure 98 Maximum rate combustion values – measured values must be within the ranges given below

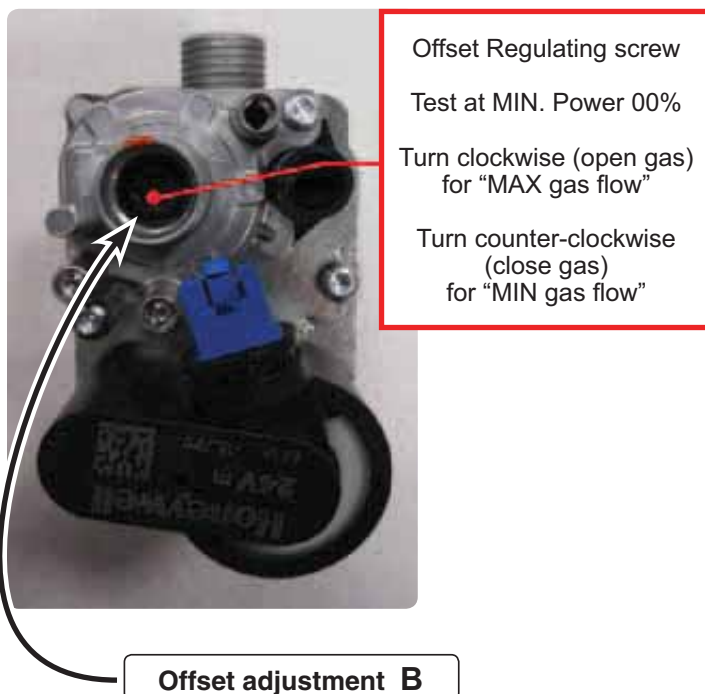
Natural Gas Acceptable Combustion Range Maximum Rate after 10 minutes from cold			
Boiler Model	CO/(PPM)	CO ₂ NG %	CO ₂ LP %
FS-80	110	9.0 - 9.5	10.2 - 10.7
FS-120	110	9.0 - 9.5	10.2 - 10.7
FS-155	120	9.0 - 9.5	10.2 - 10.7

28 Startup — final checks *(continued)*

At Minimum Rate:

1. Adjust the boiler to minimum output and allow the boiler to stabilize.
2. Now adjust the offset pressure setting (Figure 100 - cup B) Torx (T-40 male driver) until the CO₂ is at the correct SETTING LEVEL (see Figure 101), confirm that the CO/CO₂ ratio is within limits (clockwise to increase gas).

Figure 100 Offset adjustment screw —
(ONLY for use by a qualified technician, using calibrated combustion test instruments).



CAUTION Adjust in steps of no more than 1/8 of a turn and wait 1 minute after each adjustment to allow the setting to stabilize. Turning the screw too far will cause the adjustment to reverse behavior.

Figure 101 Minimum rate combustion values – measured values must be within the ranges given below

Natural Gas Acceptable Combustion Range Minimum Rate after 10 minutes from cold			
Boiler Model	CO/(PPM)	CO ₂ NG %	CO ₂ LP %
FS-80	20	8.0 - 9.0	9.0 - 9.8
FS-120	20	8.0 - 9.0	9.0 - 9.8
FS-155	7	8.0 - 9.0	9.0 - 9.8

Re-check the Minimum Rate

3. Turn off the boiler and then turn it back on and put in Test Mode at maximum for 1 minute, then reduce firing rate/high fire for 1 minutes. Reduce to minimum and re-check the minimum rate output ensuring the CO₂ setting level has remained unchanged and confirm that the CO/CO₂ ratio is within limits.
4. In the event that the CO₂ setting level with an acceptable CO/CO₂ ratio cannot be obtained please contact your Williamson-Thermoflo representative.
5. Should you require any assistance during the set up procedure contact your Williamson-Thermoflo representative if the problem cannot be addressed with the information provided in this manual.

☐ Check Heat exchanger and vent seals

1. Operate the boiler on HIGH fire.
2. A leak would appear as vapor on the surface of the mirror.
3. If there is any indication of a leak at any joint, immediately shut down the boiler.
 - a. If possible, tighten the retaining screws or nuts (without over-tightening).
 - b. If this does not correct the problem, disassemble the components where the leak appeared. Use the procedures given in the Maintenance section of this manual.
 - c. When disassembling components, inspect gaskets to see if there is damage. Replace any damaged gasket.
 - d. Contact your Williamson-Thermoflo representative if the problem cannot be addressed with the information provided in this manual.

☐ Check ignition system safety shutoff device

1. After the boiler has been installed, turn off the boiler.
2. Shut off the manual gas valve located on the gas line to cut flow of fuel to the boiler.
3. Turn on the boiler. It will start to ignite and a “d3” code will flash. After the “d3” code flash for some time the boiler will go into a Lockout condition and a “A01” code will show in the display. It means that the boiler tried to ignite without success (code “d3”) for three (3) times and when into Lockout mode (code “A01”). This means that the ignition system safety device worked properly.
4. Open the manual gas valve located on the gas line to resume fuel supply to the boiler.
5. Hit the “Reset” button once to Clear the Lockout code “A01”.

29 Check-out/startup verification

Adjust and test boiler controls

1. Follow instructions in this manual to set and verify operation of the boiler controls.
2. Follow low water cutoff manufacturers instructions (if used).

Have the following been done?

- Boiler and heat distribution units filled with water?
- Water chemistry verified per page 67?
- Sentinel X100 corrosion inhibitor added and water tested to be within range?
- Air purged from system?
- Air purged from gas piping? Piping checked for leaks?
- Condensate trap primed?
- If boiler has been converted to Liquefied Petroleum (LP) Gas is propane conversion label affixed to jacket?

⚠ WARNING FreeStyle® boilers are shipped ready to fire natural gas ONLY. To fire on propane, you must follow the instructions in this manual to install the propane venturi. See page 12 for FreeStyle® 80, 120 or 155. Failure to comply could result in severe personal injury, death or substantial property damage.

- Thermostat circuit wiring checked to ensure there are no stray voltages?
- Followed Operating Instructions, Figure 96, page 71?
- Burner flame and combustion verified per page 72?
- FreeStyle® control operation for space heating and DHW (if used) verified per this manual?
- Additional field-installed controls tested as outlined by control manufacturers? (Boiler should be operating and should go off when controls are tested. Verify controls cause automatic reset lockout or manual reset lockout as desired.)

- Additional field-installed limit control(s) set to system temperature requirements? Balancing valves and controls adjusted to provide design temperature to system?
- Flow adjusted/balanced for each zone of multiple zones systems?
- Thermostat heat anticipator (if available) set properly?
- Boiler cycled with thermostats (and with DHW aquastat, if installed) — Raised to highest setting and verified boiler goes through normal startup cycle? Lowered to lowest setting and verified boiler goes off?
- Natural gas input measured? (page 72)
- Incoming gas pressure checked by connecting manometer to gas valve ahead of boiler? (Gas pressure must be at least the minimum values given on page 16, with boiler operating at high fire, and no more than 13 inches (330 mm) w.c. with boiler operating or boiler off.)
- Observed several operating cycles for proper operation?
- Room thermostats set to desired room temperature (and DHW aquastat, if installed, to desired DHW storage temperature)?
- All instructions shipped with this boiler reviewed with owner or maintenance person?
- Ignition system safety shutoff device tested?

Before leaving:

- Fill in **Installation certificate**, page 128.
- Return instructions to envelope and give to owner.

NOTICE

Fill out start-up data on the Installation and Service Certificate, page 128.

30 Annual startup and general maintenance

⚠WARNING Follow the service and maintenance procedures given throughout this manual and in component literature shipped with the boiler. Failure to perform the service and maintenance could result in damage to the boiler or system. Failure to follow the directions in this manual and component literature could result in severe personal injury, death or substantial property damage.

Figure 102 Service and maintenance schedules

Service technician (see page numbers indicated for details)		Owner maintenance (see FreeStyle® User's Information Manual)		
ANNUAL START-UP (See First-year special inspection)	• Handling ceramic fiber materials.	77		
	• Address reported problems	78		
	• Inspect boiler area	78	Daily	• Check boiler area.
	• Inspect boiler exterior	78		• Check air openings.
	• Inspect boiler interior	78		• Check pressure/ temperature gauge.
	• Check all piping for leaks	78		• Verify boiler jacket door is securely in place.
	• Check ignition wiring.	78	Monthly	• Check vent piping.
	• Check all boiler wiring	78		• Check air piping.
	• Check control settings	78		• Check relief valve.
	• Perform startup and checks	78		• Check condensate drain system.
	• Check burner flame	78		• Check automatic air vents (if used).
	• Check boiler relief valve	80		• Verify that domestic hot water is being supplied to fixtures at the correct temperature.
	• Reinstall jacket door after servicing	80	Every 6 months	• Check boiler piping (gas and water)
	• Review with owner.	80		• Operate relief valve.

31 Annual startup

HANDLING CERAMIC FIBER MATERIALS

REMOVING BURNER GASKET or COVER PLATE INSULATION

▲WARNING The FreeStyle® heat exchanger refractory contain ceramic fiber materials that have been identified as carcinogenic, or possibly carcinogenic, to humans). Ceramic fibers can be converted to cristobalite in very high temperature applications.

The International Agency for Research on Cancer (IARC) has concluded, “Crystal-line silica inhaled in the form of quartz or cristobalite from occupational sources is carcinogenic to humans (Group 1).”:

- Avoid breathing dust and contact with skin and eyes.
 - Use NIOSH certified dust respirator (N95). This type of respirator is based on the OSHA requirements for cristobalite at the time this document was written. Other types of respirators may be needed depending on the job site conditions. Current NIOSH recommendations can be found on the NIOSH web site at <http://www.cdc.gov/niosh/homepage.html>. NIOSH approved respirators, manufacturers, and phone numbers are also listed on this web site.
 - Wear long-sleeved, loose fitting clothing, gloves, and eye protection.
- Handle carefully to minimize dust that could be caused by abrasion.
- If replacement is necessary, remove the refractory from the boiler and place it in a plastic bag for disposal.
- Wash potentially contaminated clothes separately from other clothing. Rinse clothes washer thoroughly.

NIOSH stated First Aid

- Eye: Irrigate immediately
- Breathing: Fresh air.

FIRST-YEAR SPECIAL INSPECTION

1. **No later than 12 months** after the boiler is installed, perform a first-year inspection of the boiler. This should include the following **in addition to routine annual start-up procedures**.
 - a. The integrity of the flue system and the flue seals;
 - b. The integrity of the boiler combustion circuit and the relevant seals;
 - c. The operational (working) gas inlet pressure at maximum rate, as described on pages 49 and 73;
 - d. The gas rate, as described on page 49;
 - e. The combustion performance, as described on pages 72, 73 and 74 for combustion check.
 - f. Competence to carry out the check of combustion performance.
 - g. The person carrying out a combustion measurement should have been assessed as competent in the use of a flue gas analyzer and the interpretation of the results;

Periodical check

- h. To keep the unit working properly over time, it is necessary to have qualified personnel make an annual check that includes the following tests:
 - i. The control and safety devices (gas valve, flow meter, thermostats, etc.) must function correctly.
 - j. The flue pipes must be fully intact, secure and clear.
 - k. The airtight chamber must be sealed.
 - l. The air-flue terminal and ducts must be free of obstructions and leaks.
 - m. The condensate evacuation system must be efficient with no leakage or obstructions and drain condensate without backing up.
 - n. The burner and exchanger must be clean and free of scale. When cleaning, do not use chemical products or wire brushes.
 - o. The electrode must be free of scale and properly positioned.
 - p. The gas and water systems must be leak free.
 - q. The water pressure in the heating system must be about 18 pounds; fill the boiler to that pressure or the system design pressure.
 - r. The circulation pump must not be blocked.
 - s. The expansion tank must be filled.
 - t. The gas flow and pressure must correspond to that given in the respective tables.
2. Determine any follow-up maintenance and service needs based on the condition of the heat exchanger and condensate lines.
 - a. If the heat exchanger shows substantial fouling, or if condensate lines show accumulation of sediment, schedule a follow-up service call to perform the first-year inspection again, sooner than the normal twelve months between.
 - b. Heavy fouling of the exchanger or condensate lines indicates possible combustion air contamination. Inspect the air intake area carefully, and remove possible contaminants. See page 8, for products to avoid.

▲WARNING You must eliminate causes of corrosion and contamination to ensure reliable operation of the boiler and system.

31 Annual startup *(continued)*

▲WARNING The boiler should be inspected and started annually, at the beginning of the heating season, only by a qualified service technician. In addition, the maintenance and care of the boiler designated in Figure 102, page 76 and explained on the following pages must be performed to assure maximum boiler efficiency and reliability. Failure to service and maintain the boiler and system could result in equipment failure.

▲WARNING Electrical shock hazard — Turn off power to the boiler before any service operation on the boiler except as noted otherwise in this instruction manual. Failure to turn off electrical power could result in electrical shock, causing severe personal injury or death.

Address reported problems

1. Inspect any problems reported by owner and correct before proceeding.

Inspect boiler area

1. Verify that boiler area is free of any combustible materials, gasoline and other flammable vapors and liquids.
2. Verify that air intake area is free of any of the contaminants listed on page 8 of this manual. If any of these are present in the boiler intake air vicinity, they must be removed. If they cannot be removed, reinstall the air and vent lines per this manual.

Inspect boiler exterior

1. The boiler door, panels and aesthetic parts can be cleaned with a soft damp cloth, possibly soaked in soapy water. Do not use any abrasive detergents and solvents.

Inspect boiler interior

1. Remove jacket door and inspect interior of boiler.
2. Vacuum any sediment from the inside of the boiler and components. Remove any obstructions.

▲WARNING Do not use solvents to clean any of the boiler components. The components could be damaged, resulting in unreliable or unsafe operation.

Check all piping for leaks

▲WARNING Eliminate all system or boiler leaks. Continual fresh make-up water will reduce boiler life. Minerals can build up in the heat exchanger, reducing heat transfer, overheating heat exchanger, and causing heat exchanger failure. Leaking water may also cause severe property damage.

1. Inspect all water and gas piping and verify to be leak free.
2. Look for signs of leaking lines in the system and in the boiler and correct any problems found.
3. Check gas line for leaks, see page 71 for gas safety information.

Check ignition wiring

1. Check ignition cable electrical resistance. A good cable will have resistance between 950 and 1050 ohms. Replace if not acceptable.
2. Inspect boiler ground wire from heat exchanger access cover to ground terminal screw.
3. Verify all wiring is in good condition and securely attached.
4. Check ground continuity of wiring using continuity meter.
5. Replace ground wires if results are not satisfactory.

Check all boiler wiring

1. Inspect all boiler wiring, making sure wires are in good condition and securely attached.
2. Verify that all connectors are securely inserted.

Check control settings

1. Use the FreeStyle® control display to navigate through all settings. Adjust settings if necessary.
2. Check settings of external limit controls (if any) and adjust if necessary. Adjust as needed to accommodate the system design.

Perform startup and checks

1. Start boiler and perform checks and tests specified in this manual.
2. Verify cold fill pressure is correct and that operating pressure does not go too high. Adjust water pressure and expansion tank charge pressure as necessary.
3. Complete the check-out procedure on page 75.

Check burner flame

▲WARNING The boiler contains ceramic fiber materials. Use care when handling these materials per instructions on page 77 of this manual. Failure to comply could result in severe personal injury.

1. Inspect flame through observation window.
2. If flame is unsatisfactory at either high fire or low fire, check combustion values. If combustion is properly adjusted, turn

Figure 103 Observation window



31 Annual startup *(continued)*

off boiler and allow boiler to cool down. Then remove burner and clean it thoroughly using a vacuum cleaner or compressed air. Do not use compressed air to clean burner if performed inside a building.

3. To access the burner, remove the heat exchanger cover plate following the procedure beginning on page 104.
4. If replacing the burner, ensure the burner gasket is in good condition and correctly positioned. Follow all instructions on page 105 to reinstall all components.
5. Restart the boiler.
6. Inspect the flame at high and low fire. If flame is still not acceptable, check combustion values. If combustion is properly adjusted, obtain a replacement burner from Williamson-Thermoflo.

31 Annual startup *(continued)*

Check boiler relief valve

1. Inspect the relief valve and lift the lever to verify flow as in the following warnings, excerpted from a relief valve manufacturer's warning label. Before operating any relief valve, ensure that it is piped with its discharge in a safe area to avoid severe scald potential.
2. Read page 40 before proceeding further.
3. Follow instructions below or perform procedures per relief valve manufacturer's printed instructions.

▲WARNING Safety relief valves should be reinspected AT LEAST ONCE EVERY THREE YEARS, by a licensed plumbing contractor or authorized inspection agency, to ensure that the product has not been affected by corrosive water conditions and to ensure that the valve and discharge line have not been altered or tampered with illegally. Certain naturally occurring conditions may corrode the valve or its components over time, rendering the valve inoperative. Such conditions are not detectable unless the valve and its components are physically removed and inspected. This inspection must only be conducted by a plumbing contractor or authorized inspection agency — not by the owner. Failure to reinspect the boiler relief valve as directed could result in unsafe pressure buildup, which can result in severe personal injury, death or substantial property damage.

▲WARNING Following installation, the valve lever must be operated AT LEAST ONCE A YEAR to ensure that waterways are clear. Certain naturally occurring mineral deposits may adhere to the valve, rendering it inoperative. When manually operating the lever, water will discharge and precautions must be taken to avoid contact with hot water and to avoid water damage. Before operating lever, check to see that a discharge line is connected to this valve directing the flow of hot water from the valve to a proper place of disposal. Otherwise severe personal injury or property damage may result. If no water flows, valve is inoperative. Shut down boiler until a new relief valve has been installed.

4. After following the above warning directions, if the relief valve weeps or will not seat properly, replace the relief valve. Ensure that the reason for relief valve weeping is the valve and not over-pressurization of the system due to expansion tank waterlogging or under-sizing.

Reinstall jacket door after servicing

▲WARNING

Reinstall boiler jacket door after start-up or servicing. The boiler jacket door must be securely fastened to the boiler to prevent boiler from drawing air from inside the boiler room. This is particularly important if the boiler is located in the same room as other appliances.

Failure to keep the jacket door securely sealed and fastened could result in severe personal injury or death.

Review with owner

1. Review the User's Information Manual with the owner.
2. Emphasize the need to perform the maintenance schedule specified in the User's Information Manual (and in this manual as well).
3. Remind the owner of the need to call a licensed contractor should the boiler or system exhibit any unusual behavior.
4. Remind the owner to follow the proper shutdown procedure and to schedule an annual startup at the beginning of the next heating season.

32 Troubleshooting

VERIFY PROPER OPERATION AFTER SERVICING

Before calling for troubleshooting assistance, fill in the “FreeStyle® Boiler Startup Data Collection Sheet” (page 128). Record the boiler size and CP number (located on the left side exterior of the boiler jacket).

⚠ WARNING Failure to adhere to these guidelines can result in severe personal injury, death or substantial property damage.

ELECTRICAL SHOCK HAZARD

TURN OFF ALL POWER TO THE BOILER WHEN SERVICING. Internal wiring is still powered when the switch is off.

DO NOT JUMPER DEVICES

Never jumper (bypass) any device except for momentary testing.

REINSTALL Jacket door

The boiler jacket door must be securely fastened to the boiler to prevent boiler from drawing air from inside the boiler room. This is particularly important if the boiler is located in the same room as other appliances. Failure to keep the jacket door securely fastened could result in severe personal injury or death.

BEFORE SERVICING or MAKING CONNECTIONS —

ALWAYS TURN POWER OFF TO THE BOILER TO PREVENT ELECTRICAL SURGES, WHICH CAN DAMAGE BOILER COMPONENTS.

LABEL WIRES BEFORE REMOVING

⚠ CAUTION Label all wires prior to disconnection when servicing controls. Wiring errors can cause improper and dangerous operation.

BEFORE TROUBLESHOOTING —

1. Check for 120 VAC (minimum 102 VAC to maximum 132 VAC) to boiler.
2. Check the FreeStyle® control for error codes.
3. See Figure 74, page 60 for navigation instructions and the pages following for the display key identification.

Hold reset button for 20 seconds:

- TS Flashing (parameter)
- Push heating – button
- IN flashing (information)
- Push heating – button
- HI flashing (history/fault)
- Push “Reset” once
- Push + to scroll error codes, refer to error code list Table 3, page 84.

To exit out, hold reset button for 20 seconds.

Figure 104 Tools and kits needed for troubleshooting.

Tool	Purpose
#2 Phillips screwdriver	Multiple uses
10 mm wrench	Remove heat exchanger cover plate
#20 long-handled Torx driver	Remove burner screws
T-40 Torx driver	For gas valve adjustment
Multimeter	Measurements on sensors and electrical components
Manometer (Inclined or digital)	Measures the INLET gas pressure to the boiler
Combustion analyzer (Digital preferred)	Combustion testing and boiler adjustments
Contact thermometer	Checking surface temperatures of heat exchanger and pipes

Check the following:

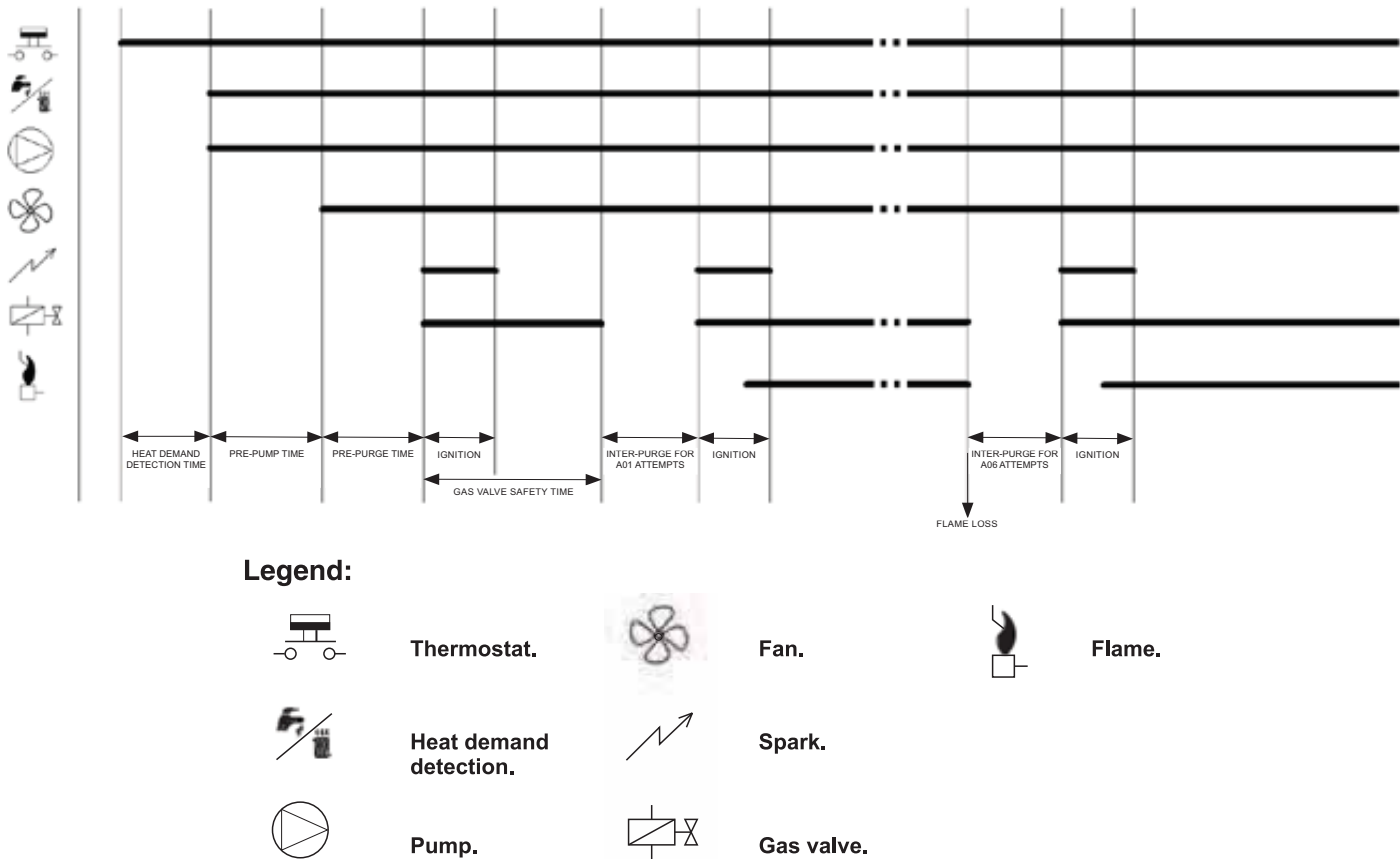
1. Make sure thermostat is calling for heat and contacts (including appropriate zone controls) are closed. Make sure all external limit controls are either installed (and closed) or temporarily jumpered for testing.
2. Make sure that connectors to FreeStyle® control are securely plugged in at module and originating control.
3. Gas pressures:
 - Maximum: 13” w.c. with no flow (gas valve lockup pressure).
 - Minimum: must be no less than the minimum values given on page 16 while operating on high fire.

32 Troubleshooting *(continued)*

Check ignition sequence

The ignition sequence time line and operational description for the Combi and Heating Only boiler below help to understand the timing of the cycles. In your troubleshooting, refer to the numbers 1 through 7 as they describe each step of the ignition cycle.

Figure 105 Time line of ignition sequence for the Combi and Heating Only boilers



1. Heat demand detection time

CH mode: there is a confirming time of 3 seconds during which the demand has to be always on.

The request switch is sampled every 0.2 seconds, so the maximum delay is 3.2 seconds.

DHW instant mode: Combi boiler the maximum delay is 0.2 seconds which is the sample time of the flow sensor.

DHW storage mode: Heating Only boiler with Indirect tank the maximum delay is 0.2 seconds which is the sample time of the tank thermostat.

2. Pre-pump time

CH instant mode: CH - Pump time 30 seconds.

DHW instant mode: there is no pre-pump.

DHW storage mode: DHW Pre-pump time 30 seconds.

3. Pre-purge time

It is the time that the fan takes to reach the ignition level to effectively purge boiler venting.

4. Ignition

There are 0.2 seconds of preignition where the control checks the status of the gas valve. And then there is the

spark, for a time depends on the gas type:

Natural Gas, 1.6 seconds.

LP Gas, 4.6 seconds.

5. Gas valve safety time

With no flame the gas valve can be kept open for certain time:

Natural Gas, 3 seconds.

LP Gas, 4.8 seconds.

If at the end of this time the flame is not ionized, the gas valve has to be closed and the inter-purge time for 6 attempts is ran.

6. Inter-purge time for A01 attempts

There is 10 seconds of purge time before a new attempt after a faulty ignition. After 5 attempts the boiler goes into Lockout (code "A01"). This error condition is stopping the boiler and to get to normal operation again, manual reset is required.

7. Inter-purge time for A06 attempts

There is 1 second of purge time before a new attempt after a lost flame. If the flame disappeared 3 consecutive times within 10 minutes, the boiler goes into Lockout (code "A06") to get to normal operation again, manual reset is required.

32 Troubleshooting *(continued)*

Check flame signal

- Navigate to Diagnostics/Inputs on the FreeStyle® control display (see pages 60 to 64 for navigation instructions).
- The flame signal value must be at least 25 on low fire for a FreeStyle® 80, 120 or 155. The flame signal value must be at least 255 on high fire FreeStyle® 80, 120 or 155. , reading at times 10 equals microamps of flame signal. If the flame signal drops below this level, the FreeStyle® control will attempt to correct by increasing the blower speed to increase flame signal.
- A low flame signal may indicate a fouled ignitor or damaged ignitor cable insulation.
 - See “Inspect ignition electrode,” page 103 to remove and inspect the ignitor.
 - If required, clean the ignitor and flame rod as instructed, see page 103.
 - If cleaning the ignitor does not improve, ground wiring is in good condition, and ground continuity is satisfactory, replace the ignitor.
- If flame signal still remains low:
 - Inspect the vent and air piping.
 - Check combustion values.
 - Then inspect the heat exchanger, following the procedures given in this manual for inspecting and cleaning of the heat exchanger cover plate and other boiler components (starting on page 103).
 - Clean the heat exchanger as described in this manual if necessary, see page 106.

Check control fuse

WARNING ALWAYS check circuit fuses before replacing control or any major components (blower, etc.). If a fuse is blown, it can prevent the FreeStyle® control or other components from operating.

- Turn OFF power to boiler at external line switch. Then remove the jacket door.
- Locate fuses using Figure 106 and Figure 107.
- Remove and inspect the fuses (Item a, Figure 106 or Item b, Figure 107).
- If necessary, replace the fuses:
 - Control circuit fuse is a 250 VAC 3.15-amp rated fuse. (Littelfuse 326012P)
 - Thermostat-relay circuit fuse is a 120 Volt 630mA rated fuse. (Littelfuse 071-852 Type 5 x 20mm).

WARNING Do not jumper fuses or replace with any fuse except as specified. Failure to comply could result in severe personal injury, death or substantial property damage.

Checking temperature sensors

- The boiler temperature sensors (flue, outdoor, return water and supply water) are all resistance-type devices. Figure 108 shows the correct value for the sensor at various temperatures. For dual sensors, the temperature difference between the sensors must be no more than 10 °F. (Supply outlet 200 sensor).
- Use the resistance values at 32°F, 60°F, 70°F and 212°F to measure the sensor resistance at known temperatures (ice point, room temperature and sea level boiling point). For ice point and boiling point, insert the sensor in water at that temperature. Use an ohmmeter to read resistance value.

Figure 106 Control circuit fuse location

Fuse located on rear of circuit board

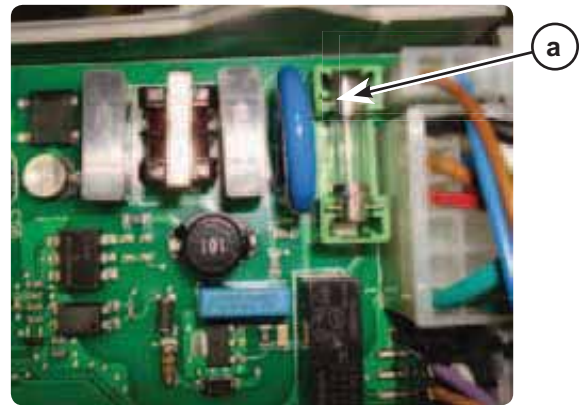
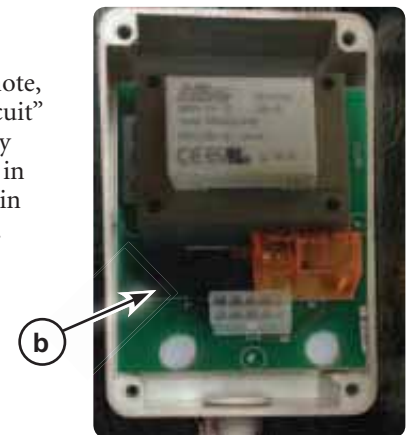


Figure 107 Thermostat-relay circuit fuse location

NOTICE

Installer/homeowner note, in case of an “open circuit” of the Thermostat-relay fuse the boiler can run in DHW mode but NOT in Central Heating mode.



- To check whether the FreeStyle® control is correctly sensing temperature, you can use a resistance decade box. Connect the decade box temporarily in place of a sensor and read the corresponding temperature on the FreeStyle® control display. The temperature should be close to the value corresponding to the input resistance.

Figure 108 Sensor resistances values

Temp (°F)	Sensor ohms		Temp (°F)	Sensor ohms		Temp (°F)	Sensor ohms	
	Min	Max		Min	Max		Min	Max
32	31530	33480	100	5608	5954	170	1344	1428
40	25792	27388	110	4590	4874	180	1143	1213
50	19258	20450	120	3636	3860	190	945	1003
60	15218	16160	130	3011	3197	200	810	860
70	11577	12293	140	2417	2567	212	657	697
80	8891	9441	150	1954	2074	-	-	-
90	7185	7629	160	1644	1746	-	-	-

32 Troubleshooting *(continued)*

▲WARNING Make sure to determine the causes of outages. Do not leave the boiler operating without a complete diagnosis.

FreeStyle® Control diagnosis

1. The FreeStyle® boiler control is equipped with an advanced self-diagnosis system. In case of a boiler fault, the display will flash together with the fault symbol (see Table 3 or 4) indicating the fault code.
2. Certain faults cause permanent boiler shutdowns (marked with the letter “A” see Table 3): to restore operation, press the RESET button (Item 6 - Figure 74, page 60) for 1 second or RESET on the optional remote timer control if installed; if the boiler fails to start, it is necessary to firstly eliminate the fault.
3. Other faults (indicated with the letter “F”, see Table 3) cause temporary shutdowns that are automatically reset as soon as the value returns within the boiler’s normal operating range.

Protection and error conditions

1. Several checks are included to protect the boiler and its environment. Severe error will cause a lockout condition which can only be cleared by the reset key at the boiler front panel.
2. Non severe errors faults will reset as soon as the cause of the problem disappears/corrects themselves.
3. Number of reset action is limited to 5 in 24 hours. By powering off/on, it is possible to reset this limitation: in this way, another 5 reset per 24 hour can be done.
4. Error codes can be divided in 2 groups:
 - a. Lock-out condition codes – “A” codes: (which blocks the heat demand - Press reset button for 1 second to reset)
 - b. Blocking condition codes – “F” codes: (cause temporary shutdowns that are automatically reset as soon as the valve returns within the boilers normal working range)

Lock out condition codes

Lock out condition is given with the capital “A” (alarm) on the status display and error code on the temperature display. The meaning of the error numbers are as follow:

Table 3 FreeStyle® list of “A” codes

Error code	Description
A01	Lockout indication
A02	False flame indication
A03	High limit protection: pump does not run or no water circulation
A04	F07 repeated 3 times in the last 24 hours
A05	No frequency feedback from fan after 1 hour
A06	6 times flame loss in 4 minutes time frame
A16	Outside sensor is not connected
A23	Nominal water pressure not reached within maximum allowed time
A24	More than 3 water fillings in 24 hours
A26	F40 repeated 3 times in the last hour
A41	Temperature sensor not or bad connected to the pipe (CH mode)
A42	Too high difference between two CH supply water temperature sensors
A44	Temperature sensor not or bad connected to the pipe (DHW mode)
A61	Flame circuit error
A62	Gas valve circuit
A63	E2 prom error
A65	ADC circuit error

Abbreviation	Description
ADC	Analog Digital Converter
CH	Central Heating
DHW	Domestic Hot Water
LP	Liquefied Petroleum (Propane) Gas
LWCO	Low Water Cut Off
MMI	Machine Interface- Control Interface
OTC	Outdoor Temperature Sensor
PCB	Printed Circuit Board - Control board
PWM	Pulse width modulation - Used for modulating pumps and motors

32 Troubleshooting *(continued)*

Figure 109 Troubleshooting suggestions for FreeStyle® boilers — **Fault displays and diagnostics** *(continued)*

Fault Code	Fault	Condition	Correction
A01	No burner ignition	No gas	Check the regular gas flow to the boiler and that the air has been eliminated from the pipes.
		Ignition/detection electrode fault	Check the wiring of the electrode and that it is correctly positioned and free of any deposits
		Combustion incorrect Natural gas & LP fuel	Perform combustion test for Natural gas & LP fuel per chart section Figure 98, page 73 and Figure 101, page 74.
		Faulty gas valve	Check the gas valve and replace it if necessary
		Insufficient gas supply pressure	Check the gas supply pressure
		Trap blocked	Check the trap and clean it if necessary Also inspect gas valve, blower, venturi, igniter, and heat exchanger, and replace those with signs of damage.
A02	Flame present signal with burner off	Electrode fault	Check the ignitor electrode wiring Electrode deformed/misaligned and/or improper gap (5/32")
		Card fault	Check the card
A03	Over temperature protection activation	Heating sensor damaged	Check the correct positioning and operation of the heating sensor
		No water circulation in the system	Check the circulating pump
		Air in the system/heat exchanger	Vent the system/purge heat exchanger
A04	Exhaust duct safety device activation	Fault F07 generated 3 times in the last 24 hours	See fault F07
A05	Fan protection activated	Fault F15 generated for 1 hour (consecutive)	See fault F15
A06	No flame after ignition stage (6 times in 4 minutes)	Ignitor electrode fault	Check the position of the ignitor electrode and replace it if necessary
		Flame unstable	Check the burner
		Gas valve Offset fault	Check the Offset adjustment at minimum power
		Air/fume ducts obstructed	Remove the obstruction from the flue, exhaust ducts and air inlet and terminals
		Trap blocked	Check the trap and clean it if necessary Also inspect gas valve, blower, venturi, igniter, and heat exchanger, and replace those with signs of damage.
F07	High exhaust temperature Air trapped in boiler heat exchanger Combustion not correct for Natural gas and LP fuel Boiler water piping and circulator not providing correct water flow	The exhaust probe detects an excessive temperature	Check the exchanger Purge out air in heat exchanger Check combustion per specification charts Figure 98, page 73 and Figure 101, page 74. Check piping sizes and required pump models
F10	Supply sensor 1 fault	Sensor damaged	Check the wiring or replace the sensor
		Wiring shorted	
		Wiring disconnected	
F11	Return sensor fault	Sensor damaged	Check the wiring or replace the sensor
		Wiring shorted	
		Wiring disconnected	
F12	DHW sensor fault	Sensor damaged	Check the wiring or replace the sensor
		Wiring shorted	
		Wiring disconnected	

32 Troubleshooting *(continued)*

Figure 110 Troubleshooting suggestions for FreeStyle® boilers — **Fault displays and diagnostics** *(continued)*

Fault Code	Fault	Condition	Correction
F13	Exhaust probe fault	Probe damaged	Check the wiring or replace the exhaust probe
		Wiring shorted	
		Wiring disconnected	
F14	Delivery sensor 2 fault	Sensor damaged	Check the wiring or replace the sensor
		Wiring shorted	
		Wiring disconnected	
F15	Fan fault	No 120V power supply	Check the 8-pin connector wiring
		Tachometric signal interrupted	Check the 8-pin connector wiring
		Fan damaged	Check the fan
		Trap blocked	Check the trap and clean it if necessary Also inspect gas valve, blower, venturi, igniter, and heat exchanger, and replace those with signs of damage.
F27	Flue temp	Exhaust gas temp too high	Make sure correct vent material was selected (Parameter List 165)
F34	Supply voltage under 100V	Electric voltage trouble	Check the electrical system
F35	Faulty voltage frequency	Electric voltage trouble	Check the electrical system
F37	Incorrect system water pressure	* Pressure too low < 8 psi	Fill the system
		Water pressure switch damaged or not connected	Check the sensor
		Check Heating Only boiler primary loop pump, must pump towards return side of boiler.	Check pump location and pump water direction
F39	Outdoor sensor fault	Sensor damaged or wiring shorted	Check the wiring or replace the sensor
		Sensor disconnected after activating the sliding temperature	Reconnect the outdoor sensor or disable the sliding temperature
A16	Outdoor sensor fault	Outdoor sensor is not connected	Check the sensor
A26	System installation	F40 Error repeated 3 times in 1 hour	Check the water pressure in the system
A41	Sensor positioning	Supply sensor disconnected from pipe	Check the correct positioning and operation of the heating sensor
A42	Heating sensor fault	Sensor damaged	Replace the sensor
A44	Temp sensor	Temp sensor not connected or badly connected to pipe (DHW mode)	Check the sensor
F43	Exchanger protection activation.	No system H2O circulation	Check the circulating pump
		Air in the system	Vent the system
F51	Low water	Low water fault	Check boiler installation and water level
F52	Heating sensor fault	Sensor damaged	Replace the sensor
F53	Temp sensor	High limit thermostat error	Check the sensor. Check boiler installation
A61	Controller ABM08 fault	Controller ABM08 internal error	Check the ground connection and replace the controller if necessary.
A62	No communication between controller and gas valve	Controller not connected	Connect the controller to the gas valve
		Valve damaged	Replace the valve
A63	Controller ABM08 fault	Controller ABM08 internal error	Check the ground connection and replace the controller if necessary.
F64			
A65			
F66			
A23			
A24	Card parameter fault	Wrong card parameter setting	Check the card parameter and modify it if necessary.
F20			
F21			
F40			
F47			

32 Troubleshooting *(continued)*

Figure 111 Troubleshooting suggestions for FreeStyle® boilers — **Fault displays and diagnostics** *(continued)*

Blocking codes

The boiler controller recognizes also the fault situations that can block the heat demands but do not lead to lockout condition. When the error condition becomes resolved, error will disappear but will be also written into the history data. If this is the case, there is also an “F” on the status display. Temperature display gives an error code. The meaning of the code is as follow:

Table 4 FreeStyle® list of “F” lockout codes

Error code	Description
F07	The Exhaust gases temperature is too high
F10	The CH supply water temperature sensor 1 error
F11	The CH return water temperature sensor error
F12	The DHW water temperature sensor error
F13	The Exhaust gases temperature sensor error
F14	The CH supply water temperature sensor 2 error
F15	Minimum and maximum frequency feedback from fan error
F20	The water pressure in the CH installation is near the low level
F21	The water pressure in the CH installation is near the high level
F27	The exhaust gas temperature is too high (PVC/CPVC selection)
F34	Low mains voltage
F35	Frequency error
F37	The water pressure in the CH installation is too low
F39	Outside sensor error
F40	The water pressure in the CH installation is too high
F43	Heat exchanger protection
F47	Water pressure sensor not connected
F50	Variable input switch contact opened
F51	Low water error
F52	Too high difference between two CH supply water temperature sensors
F53	High limit thermostat input error
F64	5 MicroCom reset in 15 minutes time frame
F66	Firmware doesn't match

Display	Condition
FAULT 07 =	If the exhaust gases temperature becomes higher than Maximum exhaust gases temperature and the high temperature is present longer than 5 seconds, controller will stop indicating fault 7, where he will stay for 15 minute. If the exhaust temperature is within normal levels after this time expired, error 7 will be resolved by itself.
FAULT 10 =	CH supply sensor 1 out of normal operating range (short circuit or open circuit). If sensor goes outside the range, error will be generated. In case sensor is back to the normal operating range, error is gone. In error mode, heat demands will be disabled. In case 2 or more sensors are broken, controller will pick up the first that was outside the operating range. Resolving situation can be achieved only if the sensor is within operating range again.

32 Troubleshooting *(continued)*

Figure 112 Troubleshooting suggestions for FreeStyle® boilers — **Fault displays and diagnostics** *(continued)*

Display	Condition
FAULT 11 =	<u>CH return sensor</u> out of normal operating range (short circuit or open circuit). If sensor goes outside the range, error will be generated. In case sensor is back to the normal operating range, error is gone. In error mode, heat demands will be disabled. In case 2 or more sensors are broken, controller will pick up the first that was outside the operating range. Resolving situation can be achieved only if the sensor is within operating range again.
FAULT 12 =	<u>DHW sensor</u> out of normal operating range (short circuit or open circuit). If sensor goes outside the range, error will be generated. In case sensor is back to the normal operating range, error is gone. In error mode, only DHW heat demands will be disabled. In case 2 or more sensors are broken, controller will pick up the first that was outside the operating range. Resolving situation can be achieved only if the sensor is within operating range again.
FAULT 13 =	<u>Exhaust sensor</u> out of normal operating range (short circuit or open circuit). If sensor goes outside the range, error will be generated. In case sensor is back to the normal operating range, error is gone. In error mode, heat demands will be disabled. In case 2 or more sensors are broken, controller will pick up the first that was outside the operating range. Resolving situation can be achieved only if the sensor is within operating range again.
FAULT 14 =	<u>CH supply sensor 2</u> out of normal operating range (short circuit or open circuit). If sensor goes outside the range, error will be generated. In case sensor is back to the normal operating range, error is gone. In error mode, heat demands will be disabled. In case 2 or more sensors are broken, controller will pick up the first that was outside the operating range. Resolving situation can be achieved only if the sensor is within operating range again.
FAULT 15 =	Fan driving problem – in case of new burner request the fan is switched on: if the controller measured a frequency lower than 20Hz or higher than 295Hz, error will be set (with a confirming time of 15 seconds). In case speed is back to the normal operating range, error is gone. In error mode, heat demands will be disabled. Resolving situation can be achieved only if the speed is within operating range again.
FAULT 20 =	Warning – The water pressure, measured by the water pressure sensor, is higher than the low level and lower than the nominal level. This is only an indication, the heat request is not switched off.
FAULT 21 =	Warning – The water pressure, measured by the water pressure sensor, is higher than the high level –4.3 psi and lower than the high level. This is only an indication, the heat request is not switched off but there is a linear output reduction in this way: if Water pressure \geq Water pressure high limit-4.3 psi there is no limitation, if Water pressure \geq Water pressure high limit-2.9psi then the maximum output is equal to (Fan absolute DHW maximum speed - Fan absolute minimum speed), if Water pressure \geq Water pressure high limit-1.5psi then the maximum output is equal to Fan absolute minimum speed + 20Hz.
FAULT 27 =	With the PVC/CPVC selection parameter equal to: <ol style="list-style-type: none"> 1. If, during the flue gas protection mode, the power reduction reaches the 0% value and the flue gas temperature is still upper than the PVC <i>maximum temperature</i>, the controller stops indicating fault 27, where it will stay for 5 minutes. The error solves itself after 5 minutes. 2. If, during the flue gas protection mode, the power reduction reaches the 0% value and the flue gas temperature is still upper than the CPVC <i>maximum temperature</i>, the controller stops indicating fault 27, where it will stay for 5 minutes. The error solves itself after 5 minutes.
FAULT 34 =	Low voltage (less than 100VAC) will trigger this error. This is only an indication, the heat request is not switched off. When voltage brought is back (over 100VAC), error is resolved. (more than 1 pump wired to pump connection point).
FAULT 35 =	The controller measures a voltage supply frequency different from the voltage supply frequency parameter. This is only an indication, the heat request is not switched off. When the controller will measure a voltage supply frequency equal to the Voltage supply frequency parameter, error will be resolved. (Example 60 Hz).

32 Troubleshooting *(continued)*

Figure 113 Troubleshooting suggestions for FreeStyle® boilers — **Fault displays and diagnostics** *(continued)*

Display	Condition
FAULT 37 =	Low water pressure error can be caused by the low water pressure in the central heating system. This can be detected in 2 ways: via low water pressure switch and via water pressure sensor (with a confirming time of 10 seconds). In error mode, the heat demand and the pumps are switched off. See Pressure supervision of the central heating installation paragraph.
FAULT 39 =	Outside sensor out of normal operating range (short circuit or open circuit). If sensor goes in short circuit and this condition lasts for more than 10 seconds, error is generated. In case sensor is back to the normal operating range, error is gone. Normal operating range for the outside sensor is from -22°F till +158°F. With sensor broken in a way that he makes an open circuit, error will be generated only if a curve is selected: OTC will be disabled but heating mode will be possible. In case 2 or more sensors are broken, controller will pick up the first that was outside the operating range. Resolving error situation can be achieved only if the sensors is within operating range again.
FAULT 40 =	High water pressure error, caused by the water pressure sensor. Water pressure is higher than high level (with a confirming time of 2 seconds). In error mode, the heat demand and the pumps are switched off. See Pressure supervision of the central heating installation paragraph.
FAULT 43 =	If the slope temperature felt by the CH supply sensor is greater of Heat exchanger protection parameter, a fault is generated due to the lack of water of the system. When the temperature felt by the CH supply sensor goes down under the 113°F, the boiler comes back into the normal operation. Each CH or Installer Test mode demand the function is disabled for the first 12 seconds starting from Gas valve opening moment. Each DHW demand the function is disabled for the first 20 seconds starting from Gas valve opening moment. Except for Comfort Mode if DHW configuration parameter is set to 1: in this case, the function is active as soon as the Gas valve opening moment. In case DHW configuration parameter is set to 1 and in case of DHW mode is running and Installer Test mode demand is created, the function is disabled for the first 12 seconds.
FAULT 47 =	Water pressure sensor not connected. In error mode, the heat demand and the pumps are switched off. Resolving error situation can be achieved only if the sensor is connected again.
FAULT 50 =	Variable input switch contact opened. See Variable input switch paragraph.
FAULT 51 =	Low water cutoff sensor open. This error can occur only when the Variable input switch functionality parameter is set to 3. This is only an indication, the heat request is not switched off.
FAULT 52 =	When the system measures a difference between two CH supply water temperature sensors equal or higher than 18°F (with a confirming time of 10 seconds), error 52 is created. This error condition is stopping the boiler and to get to the normal operation again, the temperature between the two CH supply water temperature sensors has to be lower than 14°F for 10 seconds. When this timer is expired, error will be resolved.
FAULT 53 =	High limit thermostat open. This error can occur only when the Variable input switch functionality parameter is set to 4. During fault the boiler is forced in stand-by mode.
FAULT 64 =	5 MicroCom reset in 15 minutes time frame. This error condition is stopping the boiler and to get to the normal operation again, it is necessary to take out main power supply.
FAULT 66 =	Firmware doesn't match. This error condition is stopping the boiler and to get to the normal operation again, it is necessary to re-program the device or to replace it.

32 Troubleshooting *(continued)*

Figure 114 Configuration mode for FreeStyle® boilers — Parameters, Descriptions, Default displays and Notes

Configuration mode

By pressing the DHW- and DHW+ push buttons together for 10 seconds, it is possible to enter into the Configuration mode. The display starts with showing “b01” blinking. By means of the CH “+” and CH “-” push buttons it is possible to select the parameters; between “b01” and “b28”. Selecting one of these parameters, by means of the DHW “+” and DHW “-” push buttons it is possible to adjust his value (not flashing). The value is automatically saved.

Parameter	Description	Default	Note
b01	Gas type selection (0=Natural Gas, 1=LPG)	0	
b02	DHW configuration (1=Instantaneous with double heat exchanger, 2=Storage tank, 3=Instantaneous with secondary heat exchanger, 4=Storage tank (120Vac 3 way valve))	2 - Heating Only 3 - Combi	
b03	Water pressure protection (0=Switch, 1=Sensor)	0	
b04	Fan absolute DHW maximum speed (Hz)	See Figure 119, page 93.	DHW conf. dependent
b05	Fan absolute CH maximum speed (Hz)	See Figure 119, page 93.	
b06	Fan absolute minimum speed (Hz)	See Figure 119, page 93.	
b07	DHW maximum output boost/limit level (%) - DHW config. 1 Not implemented - DHW config. 2 DHW maximum output boost/limit level (%) - DHW config. 3 Not implemented - DHW config. 4	100 -- 100 --	DHW conf. dependent
b08	DHW maximum output boost/limit time (Sec) - DHW config. 1 Not implemented - DHW config. 2 DHW maximum output boost/limit time (Sec) - DHW config. 3 Not implemented - DHW config. 4	60 -- 60 --	DHW conf. dependent
b09	Fan offset low level (Hz)	10	
b10	Summer/Winter function (0=Sum/Win, 1=always Win)	1	
b11	Variable input switch functionality (Number)	4	
b12	Variable output relay functionality (Number)	0	
b13	External pcb variable output relay functionality (Number)	7	
b14	Hours of no DHW flow to set the Economy mode (Hours)	24	
b15	Fault F20 function (0=disable, 1=enable)	0	
b16	Maximum exhaust gases temperature (°F)	185	PVC/CPVC sel. dependent
b17	Main supply frequency (0=50Hz, 1=60Hz)	1	
b18	DHW Comfort on time (Sec) - DHW config. 1 Not implemented - DHW config. 2 Not implemented - DHW config. 3 Not implemented - DHW config. 4	15 -- -- --	DHW conf. dependent
b19	DHW flow sensor filter (Sec) - DHW config. 1 DHW tank prepare mode (Num.) - DHW config. 2 DHW flow sensor filter (Sec) - DHW config. 3 DHW tank prepare mode (Num.) - DHW config. 4	0 0 0 0	DHW conf. dependent
b20	Fan type selection (0=Sit, 1=Ebm)	1	
b21	Pump protection time (Sec)	5	
b22	PVC/CPVC Selection	1	
b23	PVC maximum temperature (°F)	176	
b24	CPVC maximum temperature (°F)	185	
b25	Pre-purge time between A01 attempts	0	
b26	High altitude & Chimney length selection	0	
b27	Not implemented - DHW config. 1 Hydraulic configuration - DHW config. 2 Not implemented - DHW config. 3 Not implemented - DHW config. 4	-- 0 -- --	DHW conf. dependent
b28	Offset flame current low limit	20	

By pressing the DHW- and DHW+ push buttons together for 10 seconds, it is possible to leave the Configuration mode. If no action has been taken, the MMI automatically leaves this mode after 2 minutes.

32 Troubleshooting *(continued)*

Figure 115 Installer mode for FreeStyle® boilers

Installer mode

By pressing the RESET push button for 20 seconds, it is possible to entered the Installer mode. During this time, the OTC mode must not be entered. The display starts showing: “tS” flashing. By means of the CH+ and CH- push buttons it is possible to select “tS” or “In” or “Hi” or “rE”. “tS” means “Transparent parameter”; “In” means “Inquiry”; “Hi” means “History”; “rE” means “Reset”.

tS	blinking
Transparent parameter mode	
In	blinking
Inquiry mode	
Hi	blinking
History mode	
rE	blinking
Reset all the History information	

By means of the Reset button (1 activation for 1 second) on “tS” it is possible to enter the “Transparent parameter” mode, on “In” it is possible to enter the “Inquiry” mode, on “Hi” is possible to enter the “History” mode; by means of the ECO button (1 activation for 3 seconds) on “rE” is possible to reset all the History information.

By pressing the DHW- and DHW+ push buttons together for 10 seconds, it is possible to leave the Installer mode. If no action has been taken, the control automatically leaves this mode after 2 minutes.

“tS” as Transparent Parameters mode (TSP)

Selecting “tS” the display starts with showing “P01” blinking. By means of the CH+ and CH- push buttons it is possible to select the parameters; between “P01” and “P34”. Selecting one of these parameters, by means of the DHW+ and DHW- push buttons is possible to adjust his value (not flashing). The value is automatically saved.

Figure 116 “tS” - Transparent Parameter mode for FreeStyle® boilers

Parameter	Description	Default	Note
P01	Ignition level (%)	60 or 80	(60% - FS-120/80% - FS-80) 60% - FS-155)
P02	CH slope control (°F/min)	11	
P03	Minimum Virtual set point (°F)	95	
P04	CH OFF time (Min)	2	
P05	CH pump over-run time (Min)	15	
P06	CH pump selection (0-7)	0	
P07	CH modulating pump PWM absolute min (%)	30	
P08	CH modulating pump PWM start (%)	75	
P09	CH modulating pump PWM absolute max (%)	100	
P10	CH supply for CH pump over-run OFF (°F) - DHW config. 1 CH supply for CH pump over-run OFF (°F) - DHW config. 2 CH supply for CH pump over-run OFF (°F) - DHW config. 3 CH supply for CH pump over-run OFF (°F) - DHW config. 4	122 68 91 68	DHW conf. dependent
P11	CH supply for CH pump over-run ON (°F) - DHW config. 1 CH supply for CH pump over-run ON (°F) - DHW config. 2 CH supply for CH pump over-run ON (°F) - DHW config. 3 CH supply for CH pump over-run ON (°F) - DHW config. 4	18 9 18 9	DHW conf. dependent
P12	CH set point limit HIGH (°F)	190	
P13	CH maximum output (%)	100	Also in Test Mode

32 Troubleshooting *(continued)*

Figure 117 “tS” - Transparent Parameter mode for FreeStyle® boilers (continued)

Parameter	Description	Default	Note
P14	DHW off mode - DHW config. 1	0	DHW conf. dependent
	Legionella protection - DHW config. 2 with sensor	0	
	Legionella protection - DHW config. 2 with thermostat	--	
	DHW off mode - DHW config. 3	0	
	Legionella protection (0=off, 1-7=on) - DHW config. 4	0	
P15	DHW Comfort switch on point (°F) - DHW config. 1	104	DHW conf. dependent
	DHW Comfort Hysteresis (°F) - DHW config. 2	4	
	DHW Comfort switch on point (°F) - DHW config. 3	104	
	DHW Comfort Hysteresis (°F) - DHW config. 4	4	
P16	Peak remove time (Sec) - DHW config. 1	0	DHW conf. dependent
	CH supply over-temp_burner ON (°F) - DHW config. 2	176	
	DHW Comfort temperature difference (°F) - DHW config. 3	36	
	CH supply over-temp_burner ON (°F) - DHW config. 4	176	
P17	DHW OFF time (Sec) - DHW config. 1	120	DHW conf. dependent
	DHW delta (°F) - DHW config. 2	18	
	DHW OFF time (Sec) - DHW config. 3	120	
	DHW delta (°F) - DHW config. 4	18	
P18	DHW set point limit HIGH (°F) - DHW config. 1	131	DHW conf. dependent
	DHW set point limit HIGH (°F) - DHW config. 2	149	
	DHW set point limit HIGH (°F) - DHW config. 3	131	
	DHW set point limit HIGH (°F) - DHW config. 4	149	
P19	DHW pump over-run time (Sec) - DHW config. 1	3	DHW conf. dependent
	DHW pump over-run time (Sec) - DHW config. 2	30	
	DHW pump over-run time (Sec) - DHW config. 3	30	
	DHW pump over-run time (Sec) - DHW config. 4	30	
P20	DHW maximum output (%)	100	
P21	DHW comfort off time1 (Min) - DHW config. 1	20	DHW conf. dependent
	Not implemented - DHW config. 2	--	
	Not implemented - DHW config. 3	--	
	Not implemented - DHW config. 4	--	
P22	DHW comfort off time2 (Min) - DHW config. 2	42	DHW conf. dependent
	Not implemented - DHW config. 2	--	
	Not implemented - DHW config. 3	--	
	Not implemented - DHW config. 4	--	
P23	Fan speed in Stand-by mode (Hz)	0	
P24	Post-Ventilation time (Sec)	27	
P25	Delta T1 (°F) - DHW config. 1	32	DHW conf. dependent
	Delta T1 (°F) - DHW config. 2	32	
	Delta T1 (°F) - DHW config. 3	32	
	Delta T1 (°F) - DHW config. 4	32	
P26	Delta T2 (°F) - DHW config. 1	63	DHW conf. dependent
	Delta T2 (°F) - DHW config. 2	63	
	Delta T2 (°F) - DHW config. 3	255	
	Delta T2 (°F) - DHW config. 4	63	
P27	Water pressure low limit (psi)	6	Fixed if the Water pressure protection is set 0=Switch
P28	Water pressure nominal (psi)	10	Fixed if the Water pressure protection is set 0=Switch
P29	Heat exchanger protection (°F/Sec) - DHW config. 1	18	DHW conf. dependent
	Not implemented - DHW config. 2	--	
	Heat exchanger protection (°F/Sec) - DHW config. 3	18	
	Not implemented - DHW config. 4	--	
P30	CH hysteresys after burner ignition (°F)	18	
P31	CH hysteresys after burner ignition timer (Sec)	60	
P32	Not implemented - DHW config. 1	--	DHW conf. dependent
	DHW slope control (°F/min) - DHW config. 2	9	
	Not implemented - DHW config. 3	--	
	DHW slope control (°F/min) - DHW config. 4	9	

32 Troubleshooting *(continued)*

Figure 118 “tS” - Transparent Parameter mode for FreeStyle® boilers (continued)

Parameter	Description	Default	Note
P33	Not implemented - DHW config. 1	--	DHW conf. dependent
	Priority Over Ride Set (min) - DHW config. 2	30	
	Not implemented - DHW config. 3	--	
	Priority Over Ride Set (min) - DHW config. 4	30	
P34	Not implemented - DHW config. 1	--	DHW conf. dependent
	Priority Over Ride Reset (min) - DHW config. 2	15	
	Not implemented - DHW config. 3	--	
	Priority Over Ride Reset (min) - DHW config. 4	15	

By pressing the RESET push button for 1 second, it is possible to escape from the “Transparent parameter” mode. By pressing the RESET push button for 20 seconds, it is possible to leave the Installer mode. If no action has been taken, the MMI automatically leaves this mode after 15 minutes.

Figure 119 Default Control Board “Transparent Parameters” for FreeStyle® boilers

Boiler Model	“b01”	“b02”	“b04”	“b05”	“b06”	“b10”	“b12”	“P01”	“P02”	“P04”
	Gas type	Boiler type	Fan Max. Freq. in DHW	Fan Max. Freq. in CH	Fan Min. Freq. in CH	S/W mode selection button	Var. Out Relay	Ignition level	CH Slope (F/min)	CH Off Time
FS-80-N-C	0=Nat. gas	3	155	155	40	1	0	80	11	2
FS-120-N-C	0=Nat. gas	3	200	200	40	1	0	60	11	2
FS-155-N-C	0=Nat. gas	3	205	205	39	1	7	60	11	2
FS-80-N-H	0=Nat. gas	2	155	155	40	1	0	80	11	2
FS-120-N-H	0=Nat. gas	2	200	200	40	1	0	60	11	2
FS-155-N-H	0=Nat. gas	2	205	205	39	1	0	60	11	2
FS-80-LP-C	1=LPG	3	145	145	40	1	0	80	11	2
FS-120-LP-C	1=LPG	3	185	185	40	1	0	60	11	2
FS-155-LP-C	1=LPG	3	200	200	40	1	7	60	11	2
FS-80-LP-H	1=LPG	2	145	145	40	1	0	80	11	2
FS-120-LP-H	1=LPG	2	185	185	40	1	0	60	11	2
FS-155-LP-H	1=LPG	2	200	200	40	1	0	60	11	2

“In” as Inquiry mode

Selecting “In” the display starts with showing “t01” blinking. By means of the CH+ and CH- push buttons it is possible to select the parameters; between “t01” and “F13”. Selecting one of these parameters, by means of the DHW+ and DHW- push buttons is possible to see his value (not flashing; only in case of negative outdoor temperature the value is flashing).

Figure 120 “In” - Inquiry mode for FreeStyle® boilers

t01	blinking
CH Supply sensor1 Temperature (°F)	between 32 and 257
t02	blinking
CH Supply sensor2 Temperature (°F)	between 32 and 257
t03	blinking
CH Return sensor Temperature (°F)	between 32 and 257
t04	blinking
DHW sensor Temperature (°F)	between 32 and 257
t05	blinking
Outdoor sensor Temperature (°F)	between -22 and 158, blinking if it is negative
t06	blinking
Exhaust sensor Temperature (°F)	between 32 and 257
F07	blinking
Actual Fan Speed (Hz)	Min=00, Max=parameter depending
L08	blinking
Actual burner load (%)	00%=Min, 125%=Max Dhw boost output
F09	blinking
Actual water flow rate (=l/min *10)	between 00 and 255

32 Troubleshooting *(continued)*

Figure 121 “In” - Inquiry mode for FreeStyle® boilers (continued)

P10	blinking
Actual water pressure (psi)	
P11	blinking
Actual PWM modulating Pump (%)	Min=30, Max=100
P12	blinking
Actual Step of Triac mod. mode (Num)	Min=24, Max=59
F13	blinking
Actual Flame Current (=uA*10)	between 00 and 255

- In case of Water pressure switch: “00” means open, “20” means closed.
- In case of sensors in short circuit or open circuit, the display visualizes: “--”.
- Actual Fan Speed is showed always in terms of Hz.
- Actual water flow rate is showed always in terms of real l/min *10 and it has to be visualized also with the input switch contact open. Example: real 1.5 l/min has to be visualized as 15.
- Actual Flame Current is showed always in terms of real uA*10. Example: real 0.3 uA*10 has to be visualized as 3.
- In case of DHW thermostat, t04: “On” means closed, “OFF” means open.

By pressing the RESET push button for 1 second, it is possible to escape from the “Inquiry” mode. By pressing the RESET push button for 20 seconds, it is possible to leave the Installer mode. If no action has been taken, the MMI automatically leaves this mode after 15 minutes.

“Hi” as History mode

Selecting “Hi” the display starts with showing “H01” blinking. By means of the CH+ and CH- push buttons it is possible to select the parameters; between “H01” and “H08”. Selecting one of these parameters, by means of the DHW+ and DHW- push buttons, it is possible to see this value (not flashing).

Figure 122 “Hi” - History mode for FreeStyle® boilers

H01	blinking
History buffer 1 (the latest)	
H02	blinking
History buffer 2	
H03	blinking
History buffer 3	
-----	-----
H08	blinking
History buffer 08	

By pressing the RESET push button for 1 second, it is possible to escape from the “History” mode. By pressing the RESET push button for 20 seconds, it is possible to leave the Installer mode. If no action has been taken, the MMI automatically leaves this mode after 15 minutes.

32 Troubleshooting *(continued)*

Figure 123 Troubleshooting suggestions for FreeStyle® boilers — **Fault displays and diagnostics** *(continued)*

System Parameters list (default settings)

There are 4 basic configurations within the DHW mode, selected by parameter DHW configuration (see Parameters list, Num. 1). Default value is 1 and it represents configuration 1. By changing DHW configuration (see Parameters list, Num. 1), all the data will be automatically set at default condition. Parameters that will be changed according to the DHW mode are numbered from 9 to 46 (see Parameters list). All the parameters can be accessed with a communication package running on the PC. Some parameters are available by the installer TSP mode on the MMI or by the OT Room unit.

Table 5 FreeStyle® list of System parameters (default settings)

Category	E2 prom parameters			Unit	Range		Def
Description	Num.	Address	Description		Low	High	Value
DHW boiler type	1	CL5 – 05C8	DHW configuration	Num	1	4	3
System	2	ML – 80D0	First start-up flag	Num	0	1	0
End user setting	3	ML – 80E2	Summer / Winter selection	Num	0	1	1
End user setting	4	ML – 80E3	Economy / Comfort selection	Num	0	1	0
End user setting	5	CL5 – 0A9D	CH set point limit - HIGH	°F	68	194	190
End user setting	6	CL5 – 056D	CH user set point	°F	68	194	158
Exhaust protection	7	CL5 – 050B	Maximum exhaust gases temperature	°F	32	255	185
Firmware version	8	ML – 80E8	Firmware version	Num	0	99	03
DHW config. 1	9,1	CL5 – 066E	DHW P factor	Num	0	255	15
DHW config. 1	10,1	CL5 – 0691	DHW I factor	Num	0	255	240
DHW config. 1	11,1	ML – 80EB	DHW FF factor	Num	0	255	0
DHW config. 1	12,1	ML – 80EC	Fan absolute DHW maximum speed	Hz	0	220	200
DHW config. 1	13,1	ML – 80ED	Fan absolute CH maximum speed	Hz	0	220	200
DHW config. 1	14,1	ML – 80EE	Fan absolute minimum speed	Hz	0	165	40
DHW config. 1	15,1	CL5 – 2D89	Fan offset low level	Hz	0	220	10
DHW config. 1	16,1	ML – 80F0	Ignition level	%	0	100	60
DHW config. 1	17,1	ML – 80F1	DHW maximum output boost/limit level	%	75	125	100
DHW config. 1	18,1	ML – 80F2	DHW maximum output boost/limit time	Sec	0	120	60
DHW config. 1	19,1	ML – 80F3	DHW over-temp_burnerOFF - fixed	°F	68	194	167
DHW config. 1	20,1	ML – 80F4	DHW over-temp_burnerON - fixed	°F	68	194	163
DHW config. 1	21,1	ML – 80F5	DHW over-temp_burnerOFF – setpoint	°F	0	200	9
DHW config. 1	22,1	ML – 80F6	DHW over-temp_burnerON – setpoint	°F	0	200	0
DHW config. 1	23,1	ML – 80F7	DHW over-temp_burnerOFF – solar	°F	0	200	18
DHW config. 1	24,1	ML – 80F8	DHW over-temp_burnerON – solar	°F	0	200	18
DHW config. 1	25,1	ML – 80F9	DHW start waiting time – solar1	Sec	0	255	5
DHW config. 1	26,1	ML – 80FA	DHW start waiting time – solar2	Sec	0	255	10
DHW config. 1	27,1	ML – 80FB	DHW start waiting time – solar3	Sec	0	255	20
DHW config. 1	28,1	CL5 – 0A5E	DHW comfort switch on point	°F	0	176	104
DHW config. 1	29,1	CL5 – 0A62	DHW comfort on time	Sec	0	104	15
DHW config. 1	30,1	ML – 80FE	DHW comfort off time1	Min	0	255	20
DHW config. 1	31,1	ML – 80FF	DHW comfort off time2	Min	0	255	42
DHW config. 1	32,1	CL5 – 05A1	DHW OFF time	Sec	30	255	120
DHW config. 1	33,1	CL5 - 0A04	DHW pump over-run time	Sec	0	255	3
DHW config. 1	34,1	CL5 – 0A6D	Delta T1	°F	0	108	32
DHW config. 1	35,1	CL5 – 0A92	Delta T2	°F	0	255	63

32 Troubleshooting *(continued)*

Figure 124 Troubleshooting suggestions for FreeStyle® boilers — **Fault displays and diagnostics** *(continued)*

Category	E2 prom parameters			Unit	Range		Def Value
	Description	Num.	Address		Description	Low	
DHW config. 1	36,1	ML – 8104	CH supply for CH pump over-run OFF	°F	32	212	122
DHW config. 1	37,1	CL5 – 0C94	CH supply for CH pump over-run ON	°F	0	200	18
DHW config. 1	38,1	ML – 8106	CH supply over-temp_burnerOFF	°F	0	212	203
DHW config. 1	39,1	ML – 8107	CH supply over-temp_burnerON	°F	32	212	194
DHW config. 1	40,1	ML – 8108	CH return over-temp_burnerOFF	°F	32	212	203
DHW config. 1	41,1	ML – 8109	CH return over-temp_burnerON	°F	32	212	194
DHW config. 1	42,1	ML – 810A	DHW set point limit – LOW	°F	50	104	104
DHW config. 1	43,1	CL5 – 1E76	DHW set point limit – HIGH	°F	104	158	131
DHW config. 1	44,1	CL5 – 05F4	DHW user set point – Default value	°F	50	158	131
DHW config. 1	45,1	ML – 810D	CH pre-pump time	Sec	0	60	30
DHW config. 1	46,1	ML – 810E	Minimum virtual set point	°F	68	176	95
DHW config. 2	9,2	CL5 – 066E	DHW P factor	Num	0	255	5
DHW config. 2	10,2	CL5 – 0691	DHW I factor	Num	0	255	240
DHW config. 2	11,2	ML – 80EB	DHW FF factor	Num	0	255	0
DHW config. 2	12,2	ML – 80EC	Fan absolute DHW maximum speed	Hz	0	220	200
DHW config. 2	13,2	ML – 80ED	Fan absolute CH maximum speed	Hz	0	220	200
DHW config. 2	14,2	ML – 80EE	Fan absolute minimum speed	Hz	0	165	40
DHW config. 2	15,2	CL5 – 2D89	Fan offset low level	Hz	0	220	10
DHW config. 2	16,2	ML – 80F0	Ignition level	%	0	100	60
DHW config. 2	17,2		Free - TBD				
DHW config. 2	18,2		Free - TBD				
DHW config. 2	19,2		Free - TBD				
DHW config. 2	20,2		Free - TBD				
DHW config. 2	21,2		Free - TBD				
DHW config. 2	22,2		Free - TBD				
DHW config. 2	23,2		Free - TBD				
DHW config. 2	24,2		Free - TBD				
DHW config. 2	25,2		Free - TBD				
DHW config. 2	26,2	ML – 80FA	DHW pre-pump time	Sec	0	30	30
DHW config. 2	27,2	ML – 80FB	Legionella protection	Num	0	7	0
DHW config. 2	28,2	CL5 – 0A5E	DHW comfort hysteresis	°F	0	176	4
DHW config. 2	29,2	CL5 – 0A62	DHW comfort temp difference	°F	0	104	0
DHW config. 2	30,2	ML – 80FE	DHW pump start temperature	°F	0	255	32
DHW config. 2	31,2	ML – 80FF	DHW pump start waiting time	Sec	0	255	0
DHW config. 2	32,2	CL5 – 05A1	DHW OFF time	Sec	30	255	120
DHW config. 2	33,2	CL5 – 0A04	DHW pump over-run time	Sec	0	255	30
DHW config. 2	34,2	CL5 – 0A6D	Delta T1	°F	0	108	32
DHW config. 2	35,2	CL5 – 0A92	Delta T2	°F	0	255	63
DHW config. 2	36,2	ML – 8104	CH supply for CH pump over-run OFF	°F	32	212	68
DHW config. 2	37,2	CL5 – 0C94	CH supply for CH pump over-run ON	°F	0	200	9
DHW config. 2	38,2	ML – 8106	CH supply over-temp_burnerOFF	°F	0	212	9
DHW config. 2	39,2	ML – 8107	CH supply over-temp_burnerON	°F	32	212	176
DHW config. 2	40,2	ML – 8108	CH return over-temp_burnerOFF	°F	32	212	203
DHW config. 2	41,2	ML – 8109	CH return over-temp_burnerON	°F	32	212	194

32 Troubleshooting *(continued)*

Figure 125 Troubleshooting suggestions for FreeStyle® boilers — **Fault displays and diagnostics** *(continued)*

Category	E2 prom parameters			Unit	Range		Def Value
	Num.	Address	Description		Low	High	
DHW config. 2	42,2	ML – 810A	DHW set point limit – LOW	°F	50	104	50
DHW config. 2	43,2	CL5 – 1E76	DHW set point limit – HIGH	°F	104	158	149
DHW config. 2	44,2	CL5 – 05F4	DHW user set point – Default value	°F	50	158	149
DHW config. 2	45,2	ML – 810D	CH pre-pump time	Sec	0	60	30
DHW config. 2	46,2	ML – 810E	Minimum virtual set point	°F	68	176	95
DHW config. 3	9,3	CL5 – 066E	DHW P factor	Num	0	255	20
DHW config. 3	10,3	CL5 – 0691	DHW I factor	Num	0	255	240
DHW config. 3	11,3	ML – 80EB	DHW FF factor	Num	0	255	0
DHW config. 3	12,3	ML – 80EC	Fan absolute DHW maximum speed	Hz	0	220	200
DHW config. 3	13,3	ML – 80ED	Fan absolute CH maximum speed	Hz	0	220	200
DHW config. 3	14,3	ML – 80EE	Fan absolute minimum speed	Hz	0	165	40
DHW config. 3	15,3	CL5 – 2D89	Fan offset low level	Hz	0	220	10
DHW config. 3	16,3	ML – 80F0	Ignition level	%	0	100	60
DHW config. 3	17,3	ML – 80F1	DHW maximum output boost/limit level	%	75	125	100
DHW config. 3	18,3	ML – 80F2	DHW maximum output boost/limit time	Sec	0	120	60
DHW config. 3	19,3	ML – 80F3	DHW over-temp_burnerOFF - fixed	°F	68	194	167
DHW config. 3	20,3	ML – 80F4	DHW over-temp_burnerON - fixed	°F	68	194	163
DHW config. 3	21,3	ML – 80F5	DHW over-temp_burnerOFF – setpoint	°F	0	200	9
DHW config. 3	22,3	ML – 80F6	DHW over-temp_burnerON – setpoint	°F	0	200	0
DHW config. 3	23,3	ML – 80F7	DHW over-temp_burnerOFF – solar	°F	0	200	18
DHW config. 3	24,3	ML – 80F8	DHW over-temp_burnerON – solar	°F	0	200	18
DHW config. 3	25,3	ML – 80F9	DHW start waiting time – solar1	Sec	0	255	5
DHW config. 3	26,3	ML – 80FA	DHW start waiting time – solar2	Sec	0	255	10
DHW config. 3	27,3	ML – 80FB	DHW start waiting time – solar3	Sec	0	255	20
DHW config. 3	28,3	CL5 – 0A5E	DHW comfort switch on point	°F	0	176	104
DHW config. 3	29,3	CL5 – 0A62	DHW comfort temp difference	°F	0	100	36
DHW config. 3	30,3	ML – 80FE	DHW pump start temperature	°F	0	255	68
DHW config. 3	31,3	ML – 80FF	DHW pump start waiting time	Sec	0	255	1
DHW config. 3	32,3	CL5 – 05A1	DHW OFF time	Sec	0	255	120
DHW config. 3	33,3	CL5 – 0A04	DHW pump over-run time	Sec	0	255	30
DHW config. 3	34,3	CL5 – 0A6D	Delta T1	°F	0	108	32
DHW config. 3	35,3	CL5 – 0A92	Delta T2	°F	0	255	255
DHW config. 3	36,3	ML – 8104	CH supply for CH pump over-run OFF	°F	32	212	91
DHW config. 3	37,3	CL5 – 0C94	CH supply for CH pump over-run ON	°F	0	200	18
DHW config. 3	38,3	ML – 8106	CH supply over-temp_burnerOFF	°F	0	212	203
DHW config. 3	39,3	ML – 8107	CH supply over-temp_burnerON	°F	32	212	194
DHW config. 3	40,3	ML – 8108	CH return over-temp_burnerOFF	°F	32	212	203
DHW config. 3	41,3	ML – 8109	CH return over-temp_burnerON	°F	32	212	194
DHW config. 3	42,3	ML – 810A	DHW set point limit – LOW	°F	50	104	104
DHW config. 3	43,3	CL5 – 1E76	DHW set point limit – HIGH	°F	104	158	131
DHW config. 3	44,3	CL5 – 05F4	DHW user set point – Default value	°F	50	158	131
DHW config. 3	45,3	ML – 810D	CH pre-pump time	Sec	0	60	30
DHW config. 3	46,3	ML – 810E	Minimum virtual set point	°F	68	176	95

32 Troubleshooting *(continued)*

Figure 126 Troubleshooting suggestions for FreeStyle® boilers — **Fault displays and diagnostics** *(continued)*

Category	E2 prom parameters			Unit	Range		Def Value
	Description	Num.	Address		Description	Low	
DHW config. 4	9,4	CL5 – 066E	DHW P factor	Num	0	255	5
DHW config. 4	10,4	CL5 – 0691	DHW I factor	Num	0	255	240
DHW config. 4	11,4	ML – 80EB	DHW FF factor	Num	0	255	0
DHW config. 4	12,4	ML – 80EC	Fan absolute DHW maximum speed	Hz	0	220	200
DHW config. 4	13,4	ML – 80ED	Fan absolute CH maximum speed	Hz	0	220	200
DHW config. 4	14,4	ML – 80EE	Fan absolute minimum speed	Hz	0	165	40
DHW config. 4	15,4	CL5 – 2D89	Fan offset low level	Hz	0	220	10
DHW config. 4	16,4	ML – 80F0	Ignition level	%	0	100	60
DHW config. 4	17,4		Free - TBD				
DHW config. 4	18,4		Free - TBD				
DHW config. 4	19,4		Free - TBD				
DHW config. 4	20,4		Free - TBD				
DHW config. 4	21,4		Free - TBD				
DHW config. 4	22,4		Free - TBD				
DHW config. 4	23,4		Free - TBD				
DHW config. 4	24,4		Free - TBD				
DHW config. 4	25,4		Free - TBD				
DHW config. 4	26,4	ML – 80FA	DHW pre-pump time	Sec	0	30	30
DHW config. 4	27,4	ML – 80FB	Legionella protection	Num	0	7	0
DHW config. 4	28,4	CL5 – 0A5E	DHW comfort hysteresis	°F	0	176	4
DHW config. 4	29,4	CL5 – 0A62	DHW comfort temp difference	°F	0	100	0
DHW config. 4	30,4	ML – 80FE	DHW pump start temperature	°F	0	255	32
DHW config. 4	31,4	ML – 80FF	DHW pump start waiting time	Sec	0	255	0
DHW config. 4	32,4	CL5 – 05A1	DHW OFF time	Sec	30	255	120
DHW config. 4	33,4	CL5 – 0A04	DHW pump over-run time	Sec	0	255	30
DHW config. 4	34,4	CL5 – 0A6D	Delta T1	°F	0	108	32
DHW config. 4	35,4	CL5 – 0A92	Delta T2	°F	0	255	63
DHW config. 4	36,4	ML – 8104	CH supply for CH pump over-run OFF	°F	32	212	68
DHW config. 4	37,4	CL5 – 0C94	CH supply for CH pump over-run ON	°F	0	200	9
DHW config. 4	38,4	ML – 8106	CH supply over-temp_burnerOFF	°F	0	200	9
DHW config. 4	39,4	ML – 8107	CH supply over-temp_burnerON	°F	32	212	196
DHW config. 4	40,4	ML – 8108	CH return over-temp_burnerOFF	°F	32	212	203
DHW config. 4	41,4	ML – 8109	CH return over-temp_burnerON	°F	32	212	194
DHW config. 4	42,4	ML – 810A	DHW set point limit – LOW	°F	50	104	50
DHW config. 4	43,4	CL5 – 1E76	DHW set point limit – HIGH	°F	104	158	149
DHW config. 4	44,4	CL5 – 05F4	DHW user set point – Default value	°F	50	158	149
DHW config. 4	45,4	ML – 810D	CH pre-pump time	Sec	0	60	30
DHW config. 4	46,4	ML – 810E	Minimum virtual set point	°F	68	176	95
Central Heating	47	constant	CH P factor	num			12
Central Heating	48	constant	CH I factor	num			245
Central Heating	49	ML – 8138	Pre-purge time in CH mode	Sec	0	255	0
Central Heating	50	CL5 – 063B	CH maximum output	%	0	100	100
Central Heating	51	CL5 – 05AE	CH OFF time	Min	0	10	2
Central Heating	52	CL5 – 05C7	CH pump over-run time	Min	0	255	15

32 Troubleshooting *(continued)*

Figure 127 Troubleshooting suggestions for FreeStyle® boilers — **Fault displays and diagnostics** *(continued)*

Category	E2 prom parameters			Unit	Range		Def
	Description	Num.	Address		Description	Low	
Central Heating	53	CL5 – 059D	CH pump selection	Num	0	7	0
Central Heating	54	CL5 – 0592	CH slope control	°F/min	1	20	11
Central Heating	55	CL5 – 055E	OTC curve selection	Num	0	10	0
Central Heating	56	CL5 – 0562	OTC temperature offset	°F	68	104	86
Central Heating	58	ML – 811A	Summer/Winter function	Num	0	1	1
Central Heating	59	ML – 8129	CH hysteresys after burner ignition	°F	11	54	18
Central Heating	60	ML – 8120	CH hysteresys after burner ignition timer	Sec	60	180	60
Dom. Hot Water	61	CL5 – 06F8	DHW maximum output	%	0	100	100
Dom. Hot Water	62		Free - TBD				
Dom. Hot Water	63	ML – 80D9	DHW flow sensor type	Num	0	1	0
Dom. Hot Water	64	CL5 – 127A	Flow sensor ON	10*/l/min	0	100	15
Dom. Hot Water	65	CL5 – 1285	Flow sensor OFF	10*/l/min	0	100	10
Dom. Hot Water	66	ML – 80DE	DHW flow sensor filter	Sec	0	10	0
Dom. Hot Water	67	ML – 811F	DHW Off mode	Num	0	4	0
Dom. Hot Water	68	ML – 813C	Hours of no DHW flow to set the Economy mode	Hours	0	24	24
System	69	ML – 8122	Variable input switch functionality	Num	0	4	4
System	70	ML – 8123	Gas type selection	Num	0	1	0
System	71	CL5 – 121C	Fan speed in Stand-by mode	Hz	0	70	0
System	72	CL5 – 0934	Water pressure low limit	psi	0	12	6
System	73	CL5 – 0A38	Water pressure nominal	psi	7	29	10
System	74	CL5 – 2EDF	Water pressure high limit	psi	36	50	41
System	75	ML – 8128	Water filling mode	Num	0	1	0
System	76	ML – 811B	Main supply frequency	Num	0	1	1
System	77	ML – 80DC	Variable output relay functionality	Num	0	8	0
System	78	ML – 812A	External pcb variable output relay functionality	Num	0	8	7
System	79	ML – 812B	CH supply2 over-temp_burnerOFF	°F	194	230	230
System	80	ML – 812C	CH supply2 over-temp_burnerON	°F	194	230	226
System	81	ML – 812D	Water pressure protection	Num	0	1	0
System	82	ML – 813B	Post-Ventilation time	Sec	0	255	27
System	83	ML – 813D	Fault F20 function	Num	0	1	0
System	84	ML – 80E0	3-way motor valve commutation timer	Sec	4	10	4
Delta T protection	85	ML – 812E	CH modulating pump PWM absolute min	%	0	100	30
Delta T protection	86	ML – 812F	CH modulating pump PWM start	%	0	100	75
Delta T protection	87	CL5 - 0C64	CH modulating pump PWM absolute max	%	0	100	100
Delta T protection	88	constant	CH Time loop	Sec			2
Delta T protection	89	constant	DHW Time loop	Sec			2
Delta T protection	90	constant	CH modulating pump PWM_decrease step	%			1
Delta T protection	91	constant	CH modulating pump PWM_update_time	Sec			4
Delta T protection	92	constant	Virtual set point_decrease step	°F			4
Delta T protection	93	constant	Virtual set point_decrease time	Sec			10
Delta T protection	94	constant	DHW Virtual set point_decrease time2	Sec			12
Delta T protection	95	constant	DHW Virtual set point_decrease time1	Sec			18
Delta T protection	96	constant	DHW Virtual set point_increase time	Sec			18
	97		Free - TBD				
	98		Free - TBD				

32 Troubleshooting *(continued)*

Figure 128 Troubleshooting suggestions for FreeStyle® boilers — **Fault displays and diagnostics** *(continued)*

Category	E2 prom parameters			Unit	Range		Def Value
	Description	Num.	Address		Description	Low	
History	99	ML – 8061	Total num. of hours with power supply ON - LSB	Num			
History	100	ML – 8060	Total num. of hours with power supply ON - MSB	Num			
History	101	ML – 8020	History buffer 1 (the latest)	Error	0	99	
History	102	ML – 8024	History buffer 2	Error	0	99	
History	103	ML – 8028	History buffer 3	Error	0	99	
History	104	ML – 802C	History buffer 4	Error	0	99	
History	105	ML – 8030	History buffer 5	Error	0	99	
History	106	ML – 8034	History buffer 6	Error	0	99	
History	107	ML – 8038	History buffer 7	Error	0	99	
History	108	ML – 803C	History buffer 8	Error	0	99	
History	109	ML – 8022	Hour when History error 1 is happened - LSB	Num			
History	110	ML – 8021	Hour when History error 1 is happened - MSB	Num			
History	111	ML – 8026	Hour when History error 2 is happened - LSB	Num			
History	112	ML – 8025	Hour when History error 2 is happened - MSB	Num			
History	113	ML – 802A	Hour when History error 3 is happened - LSB	Num			
History	114	ML – 8029	Hour when History error 3 is happened - MSB	Num			
History	115	ML – 802E	Hour when History error 4 is happened - LSB	Num			
History	116	ML – 802D	Hour when History error 4 is happened - MSB	Num			
History	117	ML – 8032	Hour when History error 5 is happened - LSB	Num			
History	118	ML – 8031	Hour when History error 5 is happened - MSB	Num			
History	119	ML – 8036	Hour when History error 6 is happened - LSB	Num			
History	120	ML – 8035	Hour when History error 6 is happened - MSB	Num			
History	121	ML – 803A	Hour when History error 7 is happened - LSB	Num			
History	122	ML – 8039	Hour when History error 7 is happened - MSB	Num			
History	123	ML – 803E	Hour when History error 8 is happened - LSB	Num			
History	124	ML – 803D	Hour when History error 8 is happened - MSB	Num			
History	125	ML – 806B	Total number of burner switching – LSB	Num			
History	126	ML – 806A	Total number of burner switching – MSB	Num			
History	127	ML – 8073	Number of CH burner switching - LSB	Num			
History	128	ML – 8072	Number of CH burner switching - MSB	Num			
History	129	ML – 8077	Number of DHW burner switching - LSB	Num			
History	130	ML – 8076	Number of DHW burner switching - MSB	Num			
History	131	ML – 8079	Number of CH hours – LSB	Num			
History	132	ML – 8078	Number of CH hours – MSB	Num			
History	133	ML – 807D	Number of DHW hours – LSB	Num			
History	134	ML – 807C	Number of DHW hours – MSB	Num			
History	135	ML – 8081	Number of Burner off hours – LSB	Num			
History	136	ML – 8080	Number of Burner off hours – MSB	Num			
History	137	ML – 8085	Number of CH Pump ON hours – LSB	Num			
History	138	ML – 8084	Number of CH Pump ON hours – MSB	Num			
History	139	ML – 808B	DHW water usage in liters – LSB	Num			
History	140	ML – 808A	DHW water usage in liters – MSB	Num			
History	141	ML – 813A	Number of Reset of the History Information	Num			

32 Troubleshooting *(continued)*

Figure 129 Troubleshooting suggestions for FreeStyle® boilers — **Fault displays and diagnostics** *(continued)*

Category	E2 prom parameters			Unit	Range		Def
	Description	Num.	Address		Description	Low	
Flame current supervision	142	ML – 80D5	Flame current on level1 offset	ADC	0	255	3
Flame current supervision	143	ML – 80DB	Flame current on level2 offset	ADC	0	255	0
Flame current supervision	144	ML – 8112	Flame current off level offset	ADC	0	255	20
System	145	ML – 8134	High altitude & Chimney length selection	Num	0	2	0
System	146	ML – 8131	Pre-purge time between A01 attempts	Min	0	60	0
System	147	ML – 80D6	Pump protection time	Sec	0	20	5
Fan Regulation	148	CL5 – 0AC8	FAN Kp Up	Num	0	100	25
Fan Regulation	149	CL5 – 0AF4	FAN Ki Up	Num	0	255	220
Fan Regulation	150	CL5 – 1B8C	FAN Kp Down	Num	0	100	25
Fan Regulation	151	CL5 – 1BB0	FAN Ki Down	Num	0	255	250
Heat exchanger protection	152	ML – 80DD	Heat exchanger protection	°F/Sec	0	27	18
DHW Config. 2	153,2	ML – 80D2	Priority Over Ride Set	°F	0	240	30
DHW Config. 2	154,2	ML – 80D3	Priority Over Ride Reset	°F	0	240	15
DHW config. 1	155,1	ML – 810F	Short tapping	Sec	0	255	30
DHW config. 1	156,1	ML – 80DF	Peak pump on fan speed	Hz	0	255	120
DHW config. 1	157,1	ML – 80D8	Peak pump switch on time	Sec	0	255	20
DHW config. 1	158,1	ML – 80CD	Peak remove time	Sec	0	20	0
DHW config. 1	159,1	ML – 80CE	Peak remove switch off temperature	°F	32	212	194
DHW config. 1	160,1	ML – 80CF	Peak pump speed	%	0	100	100
System	161	ML – 80D7	Fan type selection	Num	0	1	1
System	162	ML - 8121	High limit protection timer	Sec	0	20	10
System	163	ML – 80D4	OTC Exempt	Num	0	1	0
DHW Config. 1	164,1	ML – 80DA	DHW Comfort pump on time	Sec	0	30	2
Chimney material	165	ML – 8110	PVC/CPVC Selection	Num	0	2	1
Chimney material	166	ML – 8132	PVC maximum temperature	°F	140	212	176
Chimney material	167	ML – 8133	CPVC maximum temperature	°F	158	230	185
Wind condition	168	ML - 8135	Wind condition time	Sec	0	60	10
Wind condition	169	ML - 8136	Wind condition frequency	Hz	0	255	110
Wind condition	170	ML - 8137	Wind condition ADC	ADC	0	255	30
DHW Config. 2	171,2	ML – 8111	DHW thermostat/sensor selection	Num	0	1	0
DHW Config. 2	172,2	ML – 80C7	DHW tank prepare mode	Num	0	2	0
DHW Config. 2	173,2	ML – 80D1	DHW Delta	°F	0	35	18
DHW Config. 2	174,2	ML – 80CC	DHW slope control	°F/min	1	20	9
DHW Config. 4	172,4	ML – 80C7	DHW tank prepare mode	Num	0	2	0
DHW Config. 4	173,4	ML – 80D1	DHW Delta	°F	0	35	18
DHW Config. 4	174,4	ML – 80CC	DHW slope control	°F/min	1	20	9
DHW Config. 2	175,2	ML – 813F	Hydraulic configuration	Num	0	1	0
Flame current supervision	176	CL5 – AAA1	Offset flame current low limit	Num	1	20	20

32 Troubleshooting *(continued)*

Figure 130 Troubleshooting suggestions for FreeStyle® boilers — **Fault displays and diagnostics** *(continued)*

Some informations can be accessed with a communication package running on the PC.

Category	E2 prom parameters			Unit
	Description	Num.	Address	
Boiler	1	CL4 – A532	CH supply sensor1 temperature	°F *10
Boiler	2	CL4 – A567	CH supply sensor2 temperature	°F *10
Boiler	3	CL4 – A55B	CH return sensor temperature	°F *10
Boiler	4	CL4 -A53D	DHW sensor temperature	°F *10
Boiler	5	CL4 -A568	Exhaust sensor temperature	°F *10
Boiler	6	CL4 -1110	Water pressure sensor	Psi *10
Boiler	7	CL4 -A554	Outside temperature sensor	°F *10
Boiler	8	CL4 -0FAB MSB	Control water set point	°F
Boiler	9	CL4 -FC02 MSB	CH Virtual set point	°F
Boiler	10	CL4 -FC02 LSB	DHW Virtual set point	°F
Boiler	11	CL4 – 11DC MSB	Fan speed -Setpoint	Hz
Boiler	12	CL4 – 11DC LSB	Fan speed -Feedback	Hz
Boiler	13	CL4 – 0364	Flame current	uA *10
Boiler	14	CL4 – FAFB MSB	PWM modulating pump	%
Boiler	15	CL4 – FAFB LSB	Step of Triac modulating pump	Num
Boiler	16	CL4 – 0F0E	DHW flow sensor	Hz
Boiler	17	ML -F68B	DHW over-temp_burnerOFF-initially_Temperature	°F
OpenTherm	18	CL4 – FAF4 MSB	OT room setpoint	°F Int
OpenTherm	19	CL4 – FAF4 LSB	OT room setpoint	°F Dec
OpenTherm	20	CL4 – FAC8 MSB	OT room temp	°F Int

Parameter	Description
D1	After cycle of Domestic water mode, D1 will be displayed.
D2	When required boiler water set - point is reached D2 will be displayed.
D3	After an attempt for ignition, re-trial ignition delay is in effect (D3 is displayed).
	<ul style="list-style-type: none"> * Check for proper fuel supply. * Remove and check ignitor for proper gap, 5/32", replace if disfigured, check combustion setting Natural gas or LP. * Insure condensate is draining properly. * Insure venting size and length are correct and unobstructed.

33 Maintenance

Disconnect power

⚠ WARNING Electrical shock hazard — Disconnect all electrical power to the boiler before attempting maintenance procedures. Failure to complete could result in severe personal injury, death or substantial property damage.

Jacket side panels are now removeable for servicing

NOTICE The boiler's right and left side jacket panels are removeable, and can be removed by removing the screws on the top and bottom of each panel.

Re-install boiler jacket door after startup or servicing

⚠ WARNING Reinstall boiler jacket door after start-up or servicing. The boiler jacket door must be securely fastened to the boiler to prevent boiler from drawing air from inside the boiler room. This is particularly important if the boiler is located in the same room as other appliances.

Failure to keep the jacket door securely sealed and fastened could result in severe personal injury or death.

Start-up and check/out

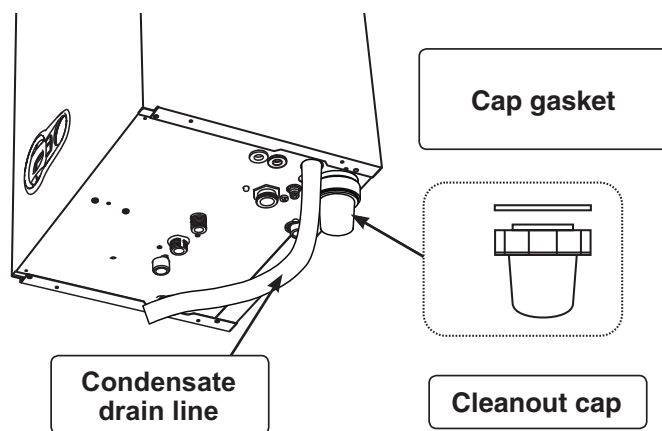
⚠ WARNING Removing and reinstalling components can change boiler behavior. After any maintenance procedure, you must prove the boiler is operating correctly. To do so, follow the complete procedure for boiler and system start-up, beginning on page 67.

Failure to comply could result in severe personal injury, death or substantial property damage.

Clean condensate trap

1. See Figure 131.
2. Disconnect top cleanout cap nut that secures the trap body to the boiler condensate connection.
3. Remove the cleanout cap.
4. Check for any sediment and clean out if necessary.
5. Re-assemble gasket and clean out cap.
6. Fill trap with fresh water by pouring into the condensate drain line. Make sure the trap line is unobstructed and flows freely.
7. Reattach the trap to the boiler condensate drain outlet. Check for secure connection.

Figure 131 Condensate trap cleaning



Inspect and clean ignition electrode

⚠ WARNING Wait until heat exchanger/boiler is cooled down before proceeding. Failure to do so can cause severe injury.

1. Disconnect the ground wire and ignition cable connected to the electrode. Ignition wire pulls out of back of control module. Remove the ignitor wire by pulling on the connector, not the wire.

Figure 132 Inspecting ignition electrode



33 Maintenance *(continued)*

Figure 133 Removal of Ignition electrode



2. Remove two (2) Phillips head screws securing the ignition electrode to the boiler heat exchanger.
3. Carefully slide the igniter out of its mounting slot.

CAUTION Use care when removing and handling igniter. Igniter is very brittle and can break if not handled carefully.

4. Remove and inspect the ignitor gasket. Replace with new if necessary.
5. Inspect the ignitor ceramic and electrodes, 5/32" gap and not bent or disfigured/warped.
6. Remove any white oxides accumulated on the ignition electrode using steel wool. If the ignition electrode cannot be cleaned satisfactorily, replace ignitor. If the igniter ceramic is cracked or damaged, replace.
7. Reinstall ignition electrode, making sure gasket is in good condition and correctly positioned.

WARNING TORQUE LIMIT — Use a torque wrench when tightening the two (2) ignition electrode retainer screws. DO NOT exceed 20 inch-pounds.

8. Re-attach the ground wire to the electrode assembly.
9. Re-connect ignition wire in the back of control module.

Figure 134 Ignition electrode grounding

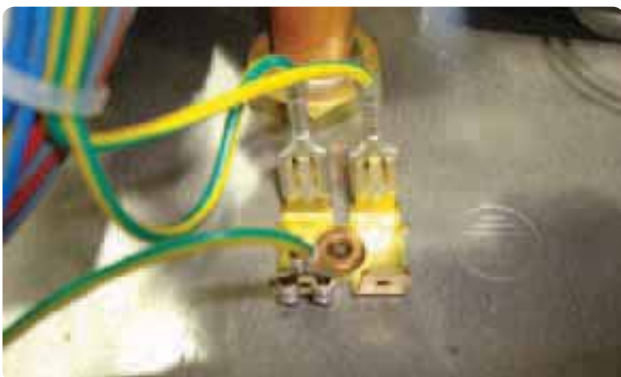


Figure 135 Boiler front panel removed (Combi 80/120 shown)



Inspect and clean the burner

WARNING Wait until heat exchanger/boiler is cooled down before proceeding. Failure to do so can cause severe injury.

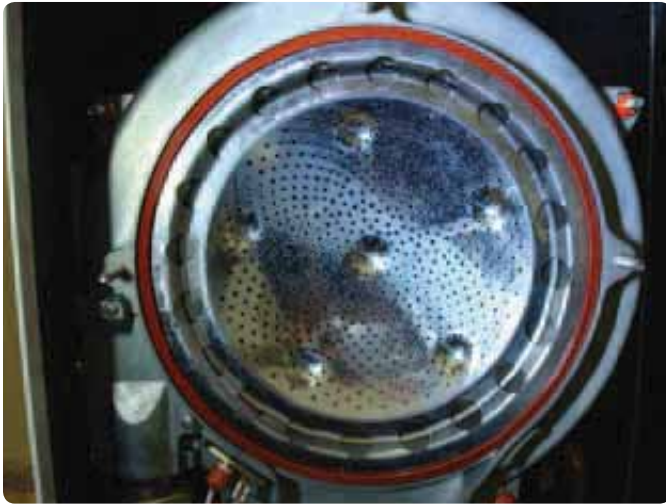
1. See Figures 135 and 140, for removing heat exchanger cover plate to access burner.
2. Use a 10mm wrench or socket to remove the five (5) nuts that secure the heat exchanger cover plate to the heat exchanger.
3. Remove the heat exchanger cover plate and the gasket.

Figure 136 Heat exchanger cover plate removed



33 Maintenance *(continued)*

Figure 137 Inspection and removal of burner and gasket



4. Remove the burner and burner gasket from the heat exchanger cover plate if still in place. Do not let fragments drop into the heat exchanger if the gasket pulls apart during removal. Replace the gasket with a new one during reassembly.
5. Inspect the burner gasket. Discard and use a new gasket during re-assembly if the gasket is damaged in any way.

Figure 138 Inspecting interior and cleaning the burner



6. Inspect the interior of the burner. Brush and vacuum the interior if needed to remove lint or sediment. Alternative cleaning methods:
 - blow air or nitrogen from the inside out;
 - clean with a water spray from inside the burner;
 - swirl the burner thoroughly in a bucket of mild liquid laundry detergent water, then rinse thoroughly.

Figure 139 Inspecting exterior and cleaning the burner



7. Inspect the burner exterior. It must be in good condition, with no visible damage.
8. Clean the underside of the burner flange with a soft brush to remove any gasket fragments remaining.
9. Reinstall spring, if removed.
10. Reinstall the burner and burner gasket to heat exchanger cover plate.
11. Reinstall exchanger cover plate and gasket to heat exchanger.
12. Tighten the heat exchanger cover plate's five (5) 10mm nuts using a torque wrench. The nuts must be secure, but the torque must not exceed 20 inch-pounds

WARNING Perform a complete start-up procedure when putting the boiler back into service. See page 67 and all instructions for start-up and verification. Include a soap suds leak test on all interior and exterior gas piping after starting the boiler.

33 Maintenance *(continued)*

Inspect and clean the heat exchanger

⚠WARNING Wait until heat exchanger/boiler is cooled down before proceeding. Failure to do so can cause severe injury.

1. See Figures 140 and 144.
2. Use a 10mm wrench or socket to remove the five (5) nuts that secure the burner cover plate to the heat exchanger.
3. Remove the heat exchanger cover plate, gasket, burner and its gasket.
4. Inspect the refractory for any damage, replace if necessary.

Figure 140 Inspecting and cleaning heat exchanger



5. Remove ignitor.
6. Before using water to clean the heat exchanger, remove the control module. Label wires if they are not labeled. Set aside. Remove all connectors and wire harnesses from the control module and then remove the screw securing it to the bracket.
7. Use a vacuum cleaner to remove any accumulation on the heating surfaces. This includes removing any pieces of refractory that may have dropped into the exchanger.

Figure 141 Cleaning the heat exchanger



8. Lightly spray clean water on all of the boiler coils and clean any residue off with (plastic only) brush. (Be careful not to damage back refractory wall).

Figure 142 Cleaning the heat exchanger



9. Wipe any residue off coils with a clean rag.
10. Spray clean water, to finish flushing combustion chamber.

Figure 143 Cleaning the heat exchanger

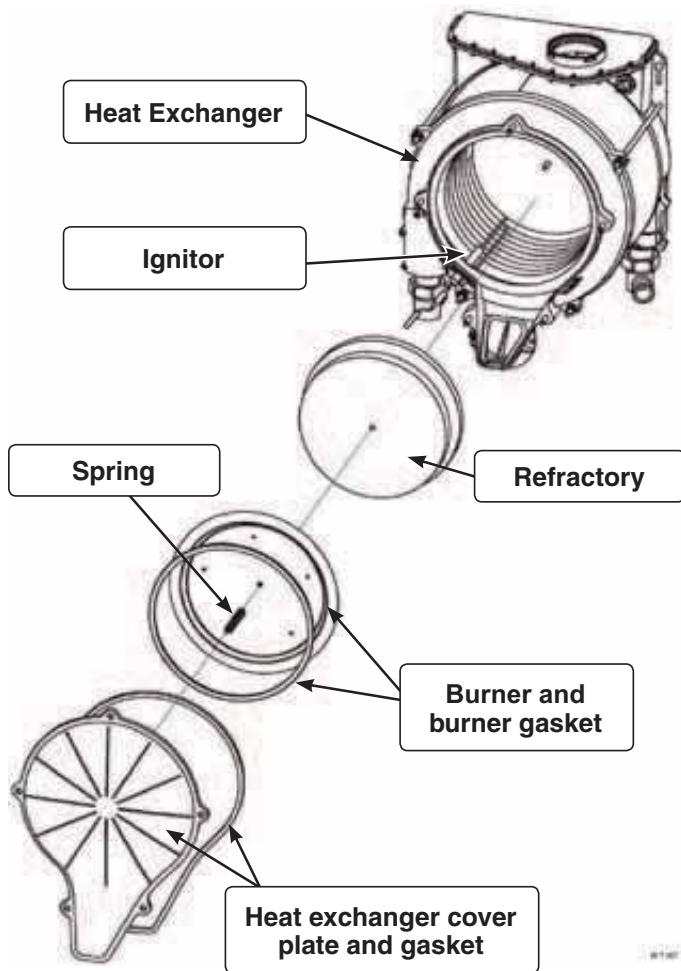


11. Dry with a clean rag.
12. Reinstall the spring.
13. Reinstall the burner, the burner gasket and ignitor.
14. Reinstall exchanger cover plate and gasket to heat exchanger.
15. Tighten the heat exchanger cover plate's five (5) 10mm nuts using a torque wrench. The nuts must be secure, but the torque must not exceed 20 inch-pounds

⚠WARNING Perform a complete start-up procedure when putting the boiler back into service. See page 67 and all instructions for start-up and verification. Include a soap suds leak test on all interior and exterior gas piping after starting the boiler.

33 Maintenance *(continued)*

Figure 144 Heat exchanger components

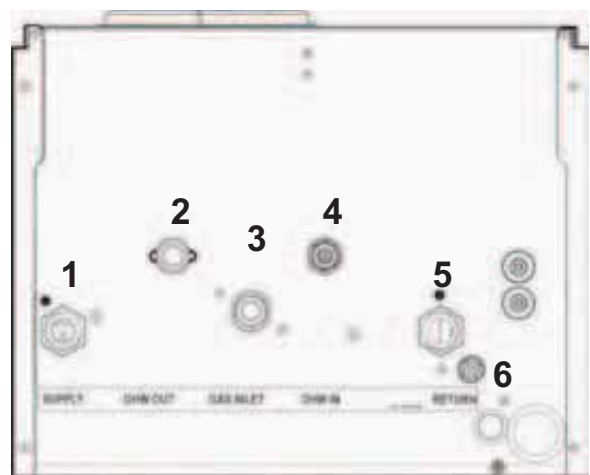


Procedure For Cleaning Of Internal Heat Exchanger Circuit

This procedure is intended as a guideline for a correct restoration of the functionality of the boiler as a result of operation with untreated water, very hard water feeding conditions, debris, lime scale, sludge, metal oxides and, in low temperature systems, also biomass in the heat exchanger water circuit.

- Carefully read and follow the instructions below.
- Cleaning and maintenance must be carried out by professionally qualified personnel, in compliance with the current regulations and according to the manufacturer's instructions. Do not carry out any operation on the sealed control parts.
- Before carrying out any cleaning or maintenance operation, disconnect the unit from the electrical power supply using the switch and/or the special cut-off devices.
- The disposal of chemicals and residues of cleaning should be carried out in an appropriate manner, in accordance with current standards.
- Before installation of the boiler, carefully flush all the pipes of the system to remove residues or impurities that could affect the proper operation of the unit. Use chemical conditioners that are suitable for the purpose. The products used must not be corrosive and/or aggressive for metals and plastics.
- If it is necessary a cleaning of the heat exchanger circuit to recover the functionality of the boiler as a result of operation with untreated water, very hard water feeding conditions, sludge, metal oxides and, in low temperature systems, also biomass in the heat exchanger water circuit, is allowed the use of chemical products for the cleaning, if and only if the manufacturer of these fluids provides a guarantee which ensures that its products are suitable for use and cause no damage to the heat exchanger or other components and / or materials of the boiler and system.

Figure 145 Heat exchanger components



- | | |
|-----------------------------|--|
| 1 System supply | 4 Domestic cold water inlet |
| 2 Domestic hot water outlet | 5 System return |
| 3 Gas inlet | 6 Plastic screw, Combi boiler pump drain |

33 Maintenance *(continued)*

Actions For Cleaning Of Heat Exchanger Water Circuit

- Disconnect the unit from the electrical power supply using the switch and/or the special cut-off devices.
- Close the valve of Heat exchanger system supply (1) and return (5) placed before the boiler connections.
- Release the pressure of Heat exchanger circuit by loosen the plastic screw placed next to the Heat exchanger return (6).
- Disconnect the system piping from 3/4" NPT Heat exchanger system supply (1) and Heat exchanger system return (5).
- Tighten the plastic screw placed next to the Heat exchanger return (6).
- Connect the two hoses of the supply for cleaning to the 3/4" NPT Heat exchanger system supply (1) and Heat exchanger system return (5) connections on the bottom of the boiler.
- Fill the pump tank with water and, if necessary, with chemical conditioners. Use chemical conditioners that are able to remove from the walls of the pipe of the heat exchanger debris, lime scale, sludge, metal oxides and, in low temperature systems, also biomass, with just the circulation of the water, with system hot and/or cold. The products used must not be corrosive and/or aggressive for metals and plastics and must not significantly alter the natural pH of the water.
- The processing time must be chosen according to the amount of deposits present in the exchanger and however such time must always be less than the maximum treatment time specified by the manufacturer on the product data sheet.
- At the end of the cleaning cycle, empty the pump from the washing water with chemical and recover the product in appropriate containers for disposal.
- Fill the pump with water and perform a washing cycle in order to remove the chemical conditioner still present within the coils of the heat exchanger, recovering the liquid in suitable containers for disposal.
- Disconnect the two hoses of the pump from the 3/4" NPT Heat exchanger system delivery (1) and Heat exchanger system return (5) connections.
- Reconnect the system piping to 3/4" NPT Heat exchanger system delivery (1) and Heat exchanger system return (5).
- Open the valve of Heat exchanger system supply (1) and return (5) placed before the boiler connections.
- Reconnect the unit to the electrical power supply using the switch and/or the special cut-off devices and turn it ON.
- Purge air from Heat exchanger water system of the boiler as described in User Manuals for the first installation of the boiler.
- Refill to correct pressure the Heat exchanger circuit.
- Check the correct operation of the boiler.

Procedure for chemical cleaning of DHW circuit

Carefully read and follow the instructions contained in this instruction booklet.

Chemical cleaning and maintenance must be carried out by professionally qualified personnel, in compliance with the current regulations and according to the manufacturer's instructions. Do not carry out any operation on the sealed control parts.

Before carrying out any cleaning or maintenance operation, disconnect the unit from the electrical power supply using the switch and/or the special cut-off devices.

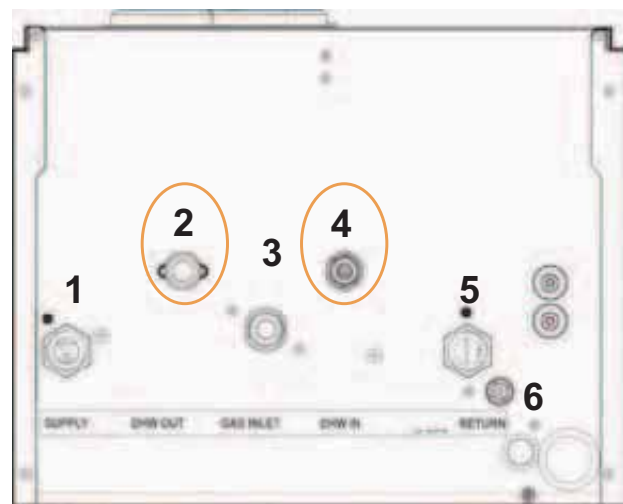
The disposal of chemicals and residues of chemical cleaning should be carried out in an appropriate manner, in accordance with current standards.

In the presence of water harder than 25° Fr (1°F = 10ppm CaCO₃), use suitably treated water in order to avoid possible scaling in the boiler.

If it is necessary a chemical cleaning of the heat exchanger to recover the functionality of domestic hot water production as a result of prolonged boiler operation with untreated water and / or very hard water feeding conditions, is allowed the use of products for the chemical cleaning, if and only if the manufacturer of these fluids provides a guarantee which ensures that its products are suitable for use and cause no damage to the heat exchanger or other components and / or materials of the boiler and system.

This procedure is intended as a guideline for a correct restoration of the functionality of domestic hot water production after prolonged boiler operation with untreated water and/or very hard water feeding conditions.

Figure 146 Boiler connections for cleaning domestic water circuit (Combi Only)



- | | |
|-----------------------------|-------------------------|
| 1 System supply | 4 Cold water inlet |
| 2 Domestic hot water outlet | 5 System return |
| 3 Gas inlet | 6 Pressure relief screw |

33 Maintenance *(continued)*

NOTICE

Before you start check the compatibility of chemical cleaning product with the material of the heat exchanger. The material of domestic hot water circuit is austenitic stainless steel, class AISI 316.

Actions for chemical cleaning of Domestic hot water circuit

1. Disconnect the unit from the electrical power supply using the switch and/or the special cut-off devices.
2. Close the valve of cold water inlet placed before the boiler inlet.
3. Release residual pressure in domestic hot water circuit in the boiler by opening a hot water tap downstream of the boiler.
4. Disconnect the piping from 1/2" cold water inlet (4) and domestic hot water outlet (2).
5. Connect the two hoses of the pump for chemical cleaning to the 1/2" cold water inlet (4) and domestic hot water outlet (2).
6. Fill the pump tank with the de-scaling chemical that is NSF approved.
7. Circulate the fluid within the domestic hot water circuit by activating the pump switch.
8. The processing time must be chosen according to the amount of scale deposits present in the exchanger and however such time must always be less than the maximum treatment time specified by the manufacturer on the product data sheet.
9. At the end of the cleaning cycle, empty the pump from chemical and recover the product in appropriate containers for disposal.
10. Fill the pump with water and perform a washing cycle in order to remove the chemical product still present within the coils of the heat exchanger, recovering the liquid in suitable containers for disposal.
11. Repeat the washing with water more than once if necessary.
12. Disconnect the two hoses of the pump for chemical cleaning from the 1/2" cold water inlet (4) and domestic hot water outlet (2).
13. Reconnect the piping to 1/2" cold water inlet (4) and domestic hot water outlet (2).
14. Open the valve of cold water inlet placed before the boiler inlet.
15. Reconnect the unit to the electrical power supply using the switch and/or the special cut-off devices and turn it ON.
16. Check the correct operation of the boiler and functionality of production of domestic hot water.

▲ DANGER

Hot Water Can Scald!

- Consumer Product Safety Commission and some states recommend domestic hot water temperature of 130°F or less.
- When installing an automatic mixing valve, selection and installation must comply with valve manufacturer's recommendations and instructions.
- Water heated to a temperature suitable for clothes washing, dish washing and other sanitizing needs will scald and cause injury.
- Children, elderly, infirm, or physically handicapped persons are more likely to be injured by hot water. Never leave them unattended in or near a bathtub, shower or sink. Never allow small children to use a hot water faucet or draw their own bath. If anyone using hot water in the building fits this description, or if state laws or local codes require certain water temperatures at hot water faucets, take special precautions:
- Install automatic mixing valve set according to those standards. (If used).
- Use lowest practical temperature setting.
- Check water temperature immediately after first heating cycle and after any adjustment.

▲ WARNING

Studies have indicated that dangerous bacteria can form in potable water distribution systems if certain minimum water temperatures are not maintained. Contact local health department for more information.

These single wall heat exchangers comply with National Standard Plumbing Code, provided that:

- Boiler water (including additives) is practically non-toxic, having a toxicity rating or class of 1, as listed in Clinical Toxicology of Commercial Products.
- Boiler water pressure is limited to max. 30 psig by approved water relief valve.

Actions for disassembling of the Domestic hot water flat plate heat exchanger

NOTICE

Consider removing side panels as noted on page 99.

1. Disconnect the unit from the electrical power supply using the switch and/or the special cut-off devices.
2. Close the valve of cold water inlet placed before the boiler inlet.
3. Release residual pressure in domestic hot water circuit in the boiler by opening a hot water tap downstream of the boiler.

▲ WARNING

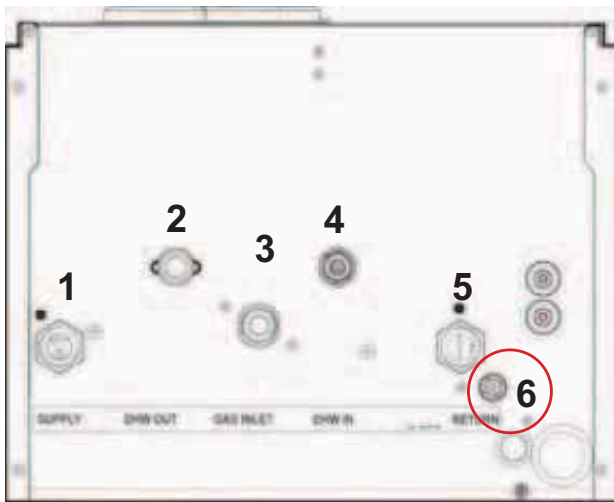
Wait until heat exchanger/boiler is cooled down before proceeding. Water in brazed plate heat exchanger may still be **HOT!** Failure to do so can cause severe injury.

33 Maintenance *(continued)*

4. Close the valve of CH system supply (1) and return (5) placed before the boiler connections.
5. Release the pressure of CH circuit by loosening the plastic screw placed next to the CH return (5), see Figure 144.

NOTICE Release Heat Exchanger pressure in the boiler by loosening the plastic screw of the pump placed next to heat exchanger return.

Figure 147 Pressure release for domestic water circuit (Combi Only)



- | | |
|-----------------------------|-----------------------------|
| 1 System supply | 4 Domestic cold water inlet |
| 2 Domestic hot water outlet | 5 System return |
| 3 Gas inlet | 6 Pressure relief screw |

6. Remove the two (2) screws securing the plate heat exchanger to the diverter valve and to the DHW inlet.
7. Pull out the flat plate heat exchanger pulling out and up from the rear of the boiler.

Figure 148 Removal of flat plate heat exchanger (screw on left side)



Figure 149 Removal of flat plate heat exchanger (screw on right side)



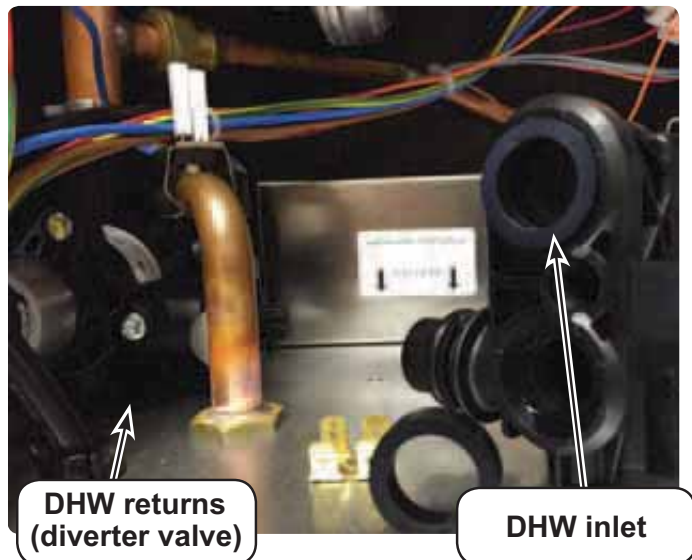
NOTICE The direction of arrows on heat exchanger. The brazed plate heat exchanger must be reinstalled in the same orientation.

The next two figures are for illustrating and information only.

The gas valve does NOT need to be removed to replace brazed plate heat exchanger

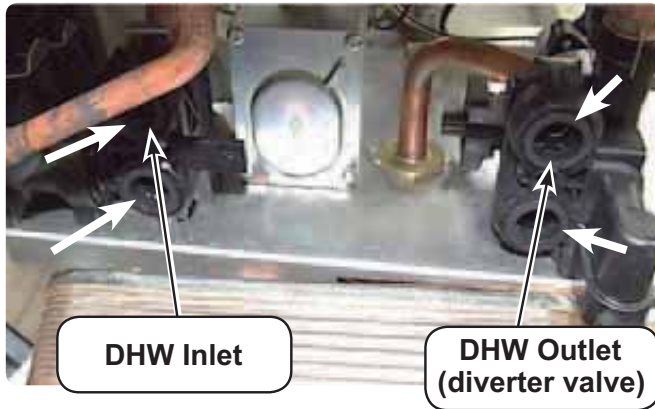
8. Flat plate heat exchanger can be immersed in a chemical cleaning bath.
9. The treatment time must be chosen according to the amount of scale deposits present in the exchanger and however such time must always be less than the maximum treatment time specified by the manufacturer on the product data sheet.

Figure 150 Reinstall the four (4) gaskets into DHW inlets and returns (components removed to show gasket locations, for illustrating purposes)



33 Maintenance *(continued)*

Figure 151 Gaskets being placed into DHW inlet and DHW return plate connections. (Shown from rear view of enclosure showing all four (4) water connections.) (Back removed for illustration purposes).



10. At the end of the cleaning cycle recover the chemical product in appropriate containers for disposal.
11. Perform a washing bath with potable water in order to remove the chemical product still present within the coils of the heat exchanger, recovering the liquid in suitable containers for disposal.
12. Repeat the washing with water more than once if necessary.
13. The cleaned brazed plate heat exchanger can now be installed.

NOTICE The four (4) new gaskets must be placed in the DHW inlet and DHW return plate connections to seal brazed plate heat exchanger.

14. Slide the brazed plate heat exchanger into rear of enclosure (orientation arrows pointing down).
15. Lift brazed plate heat exchanger slightly up and align with DHW connections, reinstall the two (2) Phillips head screws, tighten securely. (Torque to 3.3 lb-ft. +/- 0.37 lb-ft.)

WARNING When re-installing components, make sure gaskets are in good condition and properly aligned before tightening screws.

16. Reassemble boiler components check seals for any leaks.
17. Open the valve of cold water inlet placed before the boiler inlet. Run water until all air is purged from both the brazed plate heat exchanger and the primary heat exchanger.
18. Be sure the pressure relief (plastic) screw has been made tight, Location(6), see Figure 144.
19. At initial fill and during boiler startup and testing, check system thoroughly for any leaks. Repair all leaks before proceeding further.

WARNING Eliminate all system leaks. Continual fresh make up water will reduce boiler life. Minerals can build up in the heat exchanger, reducing heat transfer, overheating heat exchanger, and causing heat exchanger failure.

20. Reconnect the unit to the electrical power supply using the switch and/or the special cut-off devices and turn it ON.
21. Check the correct operation of the boiler and functionality of production of domestic hot water.

34 Replacement parts

REPLACEMENT PART NUMBERS

Williamson-Thermoflo part numbers are found in this manual and in *Williamson-Thermoflo Boilers and Controls Repair Parts Lists*.

WHEN OPERATING THE BOILER ON PROPANE GAS

▲WARNING ALL FreeStyle® boilers must be converted in order to operate with propane gas.

Figure 152 Propane conversion kits and instructions

Boiler model	Kit part number	Installation instructions
FS-80 NG	640-000-022WT	See page 12.-15.
FS-80 LP	640-000-024WT	
FS-120 NG	640-000-023WT	
FS-120 LP	640-000-025WT	
FS-155 NG	640-000-082WT	
FS-155 LP	640-000-083WT	

▲WARNING Failure to adhere to these guidelines can result in severe personal injury, death or substantial property damage.

Obtain parts only through Williamson-Thermoflo

Replacement parts must be purchased through a local Williamson-Thermoflo distributor. When ordering, specify boiler model and size and include description and part number of replacement part. Results from using modified or other manufactured parts will not be covered by warranty and may damage boiler or impair operation.

The boiler contains ceramic fiber materials

The boiler contains ceramic fiber materials. Use care when handling these materials per instructions on page 77 of this manual. Failure to comply could result in severe personal injury.

Reinstall jacket door

Inspect boiler jacket door front of cabinet and reinstall boiler jacket door after start or servicing. The boiler jacket door must be securely fastened to the boiler to prevent boiler from drawing air from inside the boiler room. This is particularly important if the boiler is located in the same room as other appliances. Failure to keep the jacket door securely fastened could result in severe personal injury or death.

BEFORE SERVICING or MAKING CONNECTIONS —

ALWAYS TURN POWER OFF TO THE BOILER TO PREVENT ELECTRICAL SURGES, WHICH CAN DAMAGE BOILER COMPONENTS.

Label wires before removing

Label all wires prior to disconnection when servicing controls. Wiring errors can cause improper and dangerous operation.

34 Replacement parts *(continued)*

Figure 153 Miscellaneous parts and kits

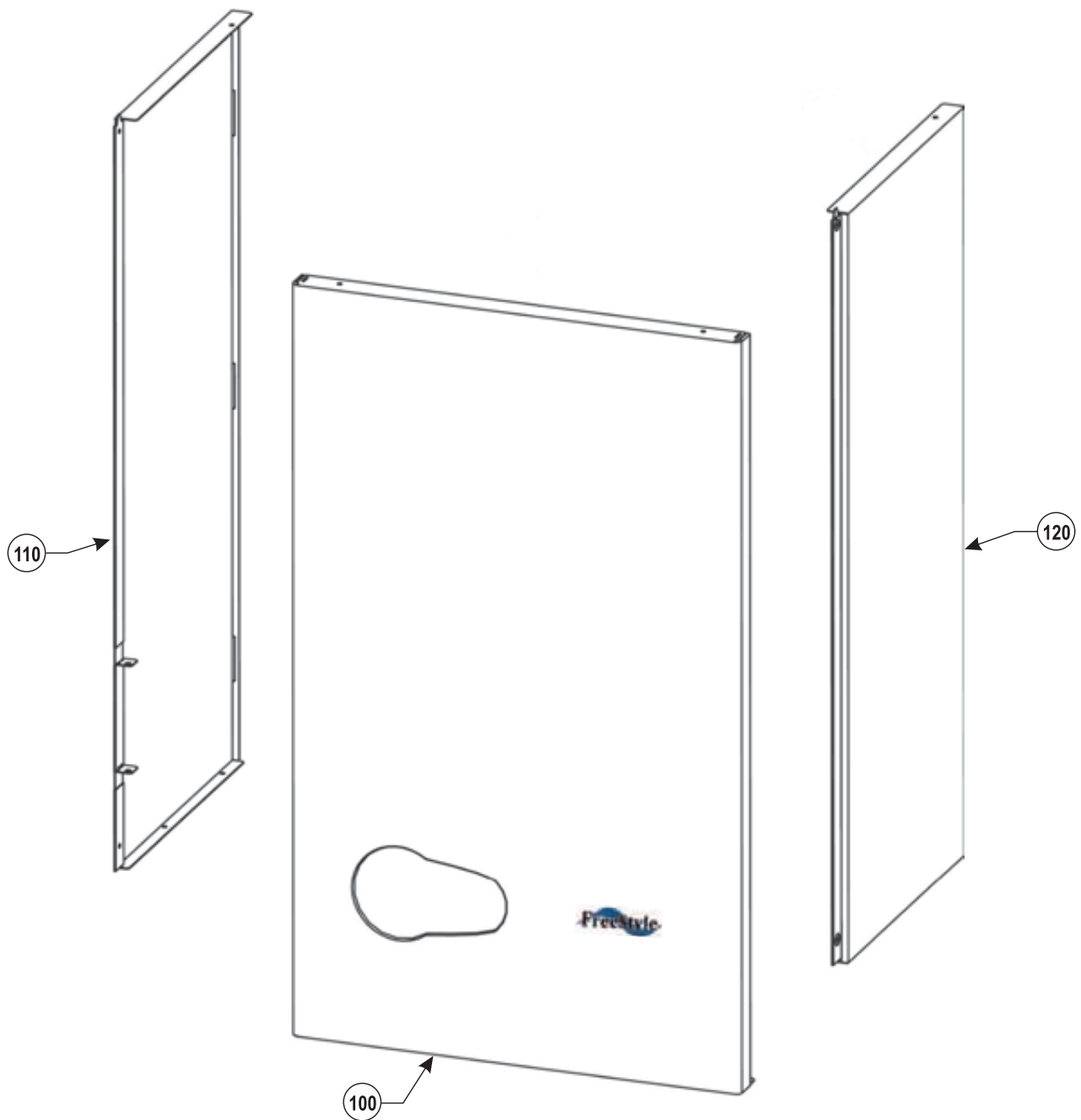
Description	Part Number
Antifreeze, Sentinel X500	592-900-029WT
Corrosion inhibitor, Sentinel X100	592-900-002WT
Quick Test Kit, Sentinel X100	592-900-005WT
Cleaner, Sentinel X400	592-900-003WT
Water Treatment Injection Kit	383-600-082WT
Wall-mount kit (supplied with boiler) — wall mount bracket and hardware	640-000-044WT
Condensate trap kit (supplied with boiler) — condensate trap assembly and flexible line	640-000-057WT
Condensate neutralizer kit	383-500-631WT
Sidewall separate pipes vent/air termination kits (includes two cover plates)	
Kit for 2" PVC vent and air pipes	383-700-171WT
Kit for 3" PVC vent and air pipes	383-500-100WT
Kit for 3" AL29-4C and air pipe	383-700-172WT
PVC concentric vent kit — horizontal or vertical (includes components for concentric assembly)	
Kit for 2" PVC vent and air pipes	383-700-167WT
Kit for 3" PVC vent and air pipes	383-500-350WT
Bird screens (1 screen each)	
For 2" PVC vent and air pipes	383-500-106WT
For 3" PVC vent and air pipes	383-500-105WT

Description	Part Number
M&G Simpson-Duravent PolyPro SIDEWALL concentric vent/air kit (color: white)	
2" polypropylene pipe	2PPS-HK
3" polypropylene pipe	3PPS-HK
M&G Simpson-Duravent PolyPro VERTICAL concentric vent/air kit; color = black (part number shown) or terra cotta (add -TC suffix)	
2" polypropylene pipe	2PPS-VK
3" polypropylene pipe	3PPS-VK
M&G Simpson-Duravent PolyPro SIDEWALL separate air and vent pipes	
2" polypropylene pipe	2PPS-HTP
3" polypropylene pipe	3PPS-HTP
Centrotherm INNOFLUE SIDEWALL concentric vent/air kit	
3" polypropylene pipe	ICWT352
2" stainless steel/pp pipe	ICWS2413
3" stainless steel/pp pipe	ICWS3513
Centrotherm INNOFLUE VERTICAL concentric vent/air kit	
2" polypropylene pipe	ICRT2439
3" polypropylene pipe	ICRT3539

34 Replacement parts *(continued)*

Figure 154 Jacket parts — FreeStyle® 80/120/155 (sheet metal for Combi and Heating Only boilers)

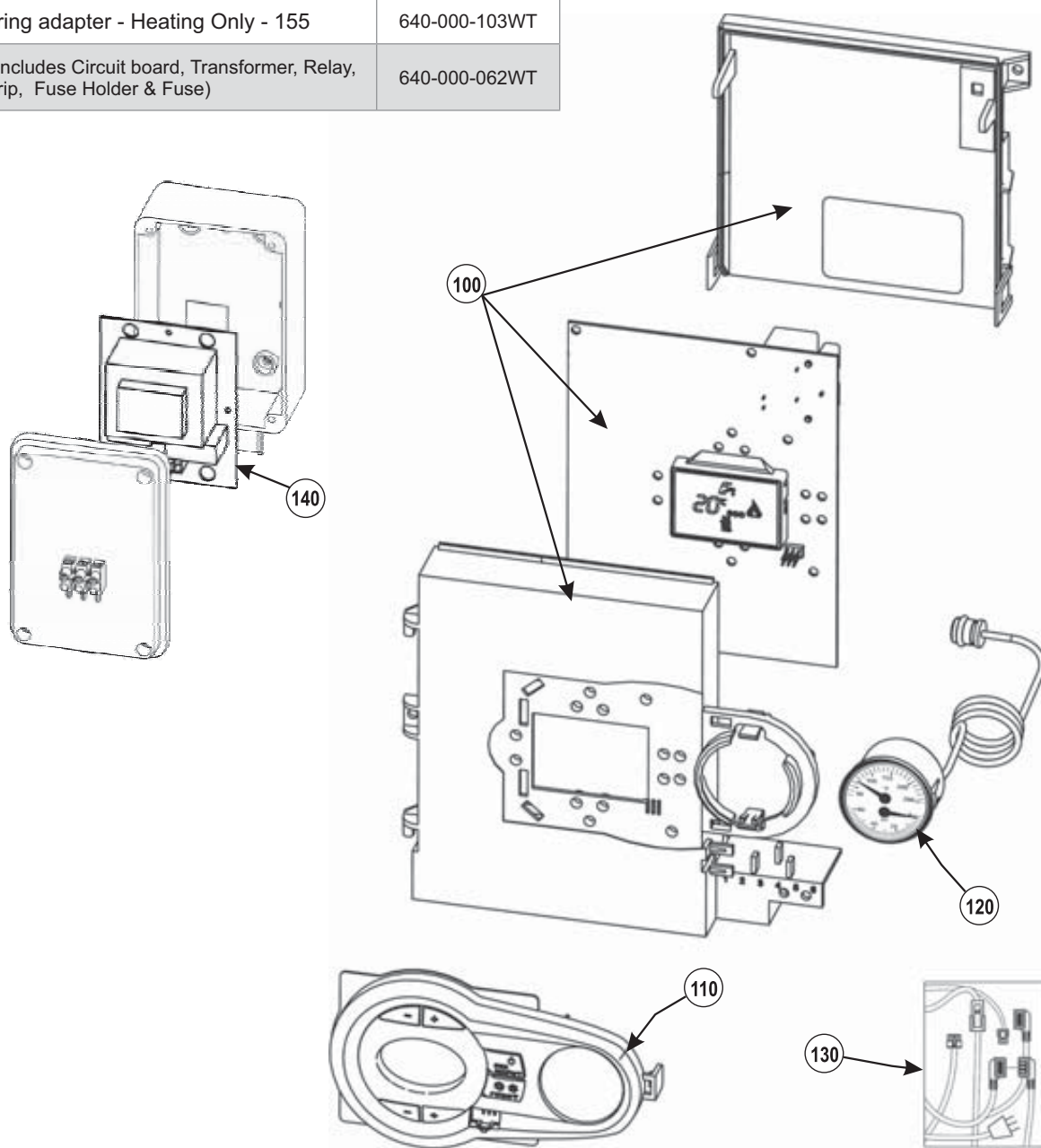
Item	Name	Part Number
100	Jacket door	640-000-067WT
110	Jacket left side	640-000-065WT
120	Jacket right side	640-000-066WT



34 Replacement parts *(continued)*

Figure 155 Control and electrical assemblies — FreeStyle® 80/120/155

Item	Name	Part Number
100	Control module assembly	640-000-003WT
110	Control module display cover	640-000-004WT
120	Pressure-Temperature assembly	640-000-006WT
130	Wire harness assembly - Combi - 80/120	640-000-005WT
	Wire harness assembly - Combi - 155	640-000-085WT
	Wire harness assembly - Heating Only	640-000-053WT
	Blower wiring adapter - Heating Only - 155	640-000-103WT
140	PCB only (includes Circuit board, Transformer, Relay, Terminal strip, Fuse Holder & Fuse)	640-000-062WT



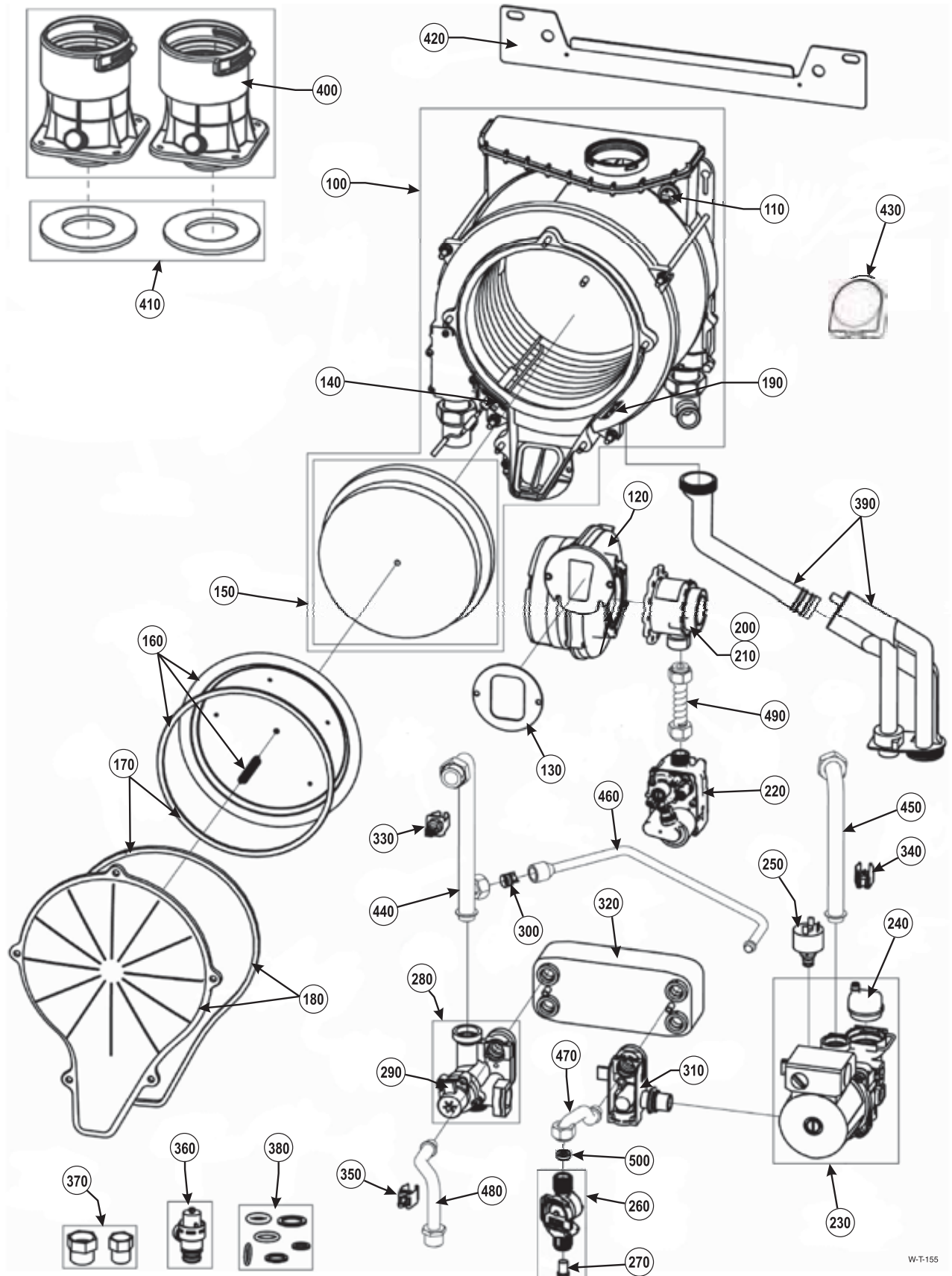
34 Replacement parts *(continued)*

Figure 156 Boiler replacement kits and parts FreeStyle® 80/120 (Combi)

Item	Name	Part Number	Model	
			FS-80	FS-120
100	Heat Exchanger	640-000-008WT	●	—
		640-000-009WT	—	●
110	Flue Sensor Temperature	640-000-011WT	●	●
120	Blower Assembly	640-000-020WT	●	●
130	Blower Gasket	640-000-021WT	●	●
140	Ignitor	640-000-109WT	●	●
150	Central Heat Exchanger Insulation	640-000-010WT	●	●
160	Burner	640-000-012WT	●	●
170	Burner Gasket Set	640-000-013WT	●	●
180	Burner Cover	640-000-016WT	●	●
190	Inspection Glass	640-000-015WT	●	●
200	Kit - Natural Gas Conversion	640-000-022WT	●	—
		640-000-023WT	—	●
210	Kit - Liquefied Petroleum (Propane) Gas Conversion	640-000-024WT	●	—
		640-000-025WT	—	●
220	Gas Valve VK8205V	640-000-037WT	●	●
230	Circulator FX3-FP	640-000-017WT	●	●
240	Air Separator	640-000-018WT	●	●
250	Water Pressure Switch	640-000-019WT	●	●
260	Flow Meter	640-000-026WT	●	●
270	Water Filter	640-000-027WT	●	●
280	Valve 3- Way	640-000-028WT	●	●
290	Motor 3- Way Valve	640-000-029WT	●	●
300	N/R Valve Fitting	640-000-030WT	●	●
310	DHW R. Plate Connection	640-000-031WT	●	●
320	Plate Exchanger 16P.	640-000-032WT	●	—
	Plate Exchanger 20P.	640-000-033WT	—	●
330	CH Temperature Probe DP	640-000-034WT	●	●
340	CH Temperature Probe US	640-000-035WT	●	●
350	DHW Temperature Probe US	640-000-036WT	●	●
360	Relief Valve 3/4"	640-000-038WT	●	●
370	NPT Adapters	640-000-039WT	●	●
380	Gasket Set	640-000-007WT	●	●
390	Condensate Drain Trap	640-000-068WT	●	●
400	Vent Adapters (2 adapters in kit)	640-000-107WT	●	●
410	Gaskets - Vent Adapter (2 gaskets in kit)	640-000-108WT	●	●
420	Wall Mount Bracket	640-000-044WT	●	●
430	Outdoor Temperature Sensor	640-000-043WT	●	●
440	CH - Flow Pipe	640-000-069WT	●	—
		640-000-070WT	—	●
450	CH - Return Pipe	640-000-071WT	●	●
460	Bypass Pipe	640-000-049WT	●	●
470	Flow Meter Pipe	640-000-050WT	●	●
480	DHW Outlet Pipe	640-000-051WT	●	●
490	Gas Pipe	640-000-072WT	●	●
500	Flow Regulator (4 GPM) (Restrictor)	640-000-110WT	●	●

34 Replacement parts *(continued)*

Figure 157 Boiler replacement kits and parts FreeStyle® 80/120 (Combi) *continued*



W-T-155

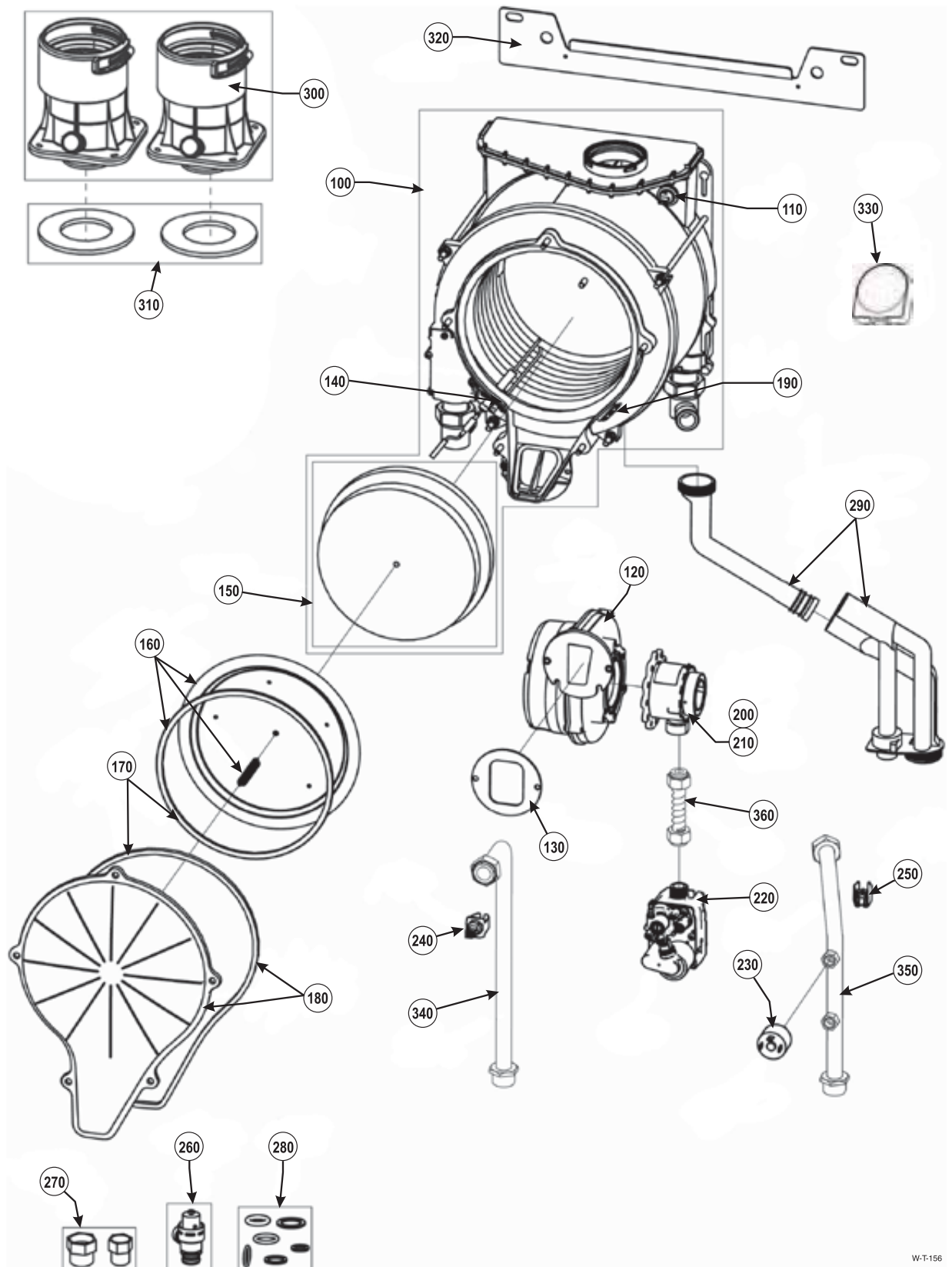
34 Replacement parts *(continued)*

Figure 158 Boiler replacement kits and parts FreeStyle® 80/120 (Heating Only)

Item	Name	Part Number	Model	
			FS-80	FS-120
100	Heat Exchanger	640-000-008WT	●	—
		640-000-009WT	—	●
110	Flue Sensor Temperature	640-000-011WT	●	●
120	Blower Assembly	640-000-020WT	●	●
130	Blower Gasket	640-000-021WT	●	●
140	Ignitor	640-000-109WT	●	●
150	Central Heat Exchanger Insulation	640-000-010WT	●	●
160	Burner	640-000-012WT	●	●
170	Burner Gasket Set	640-000-013WT	●	●
180	Burner Cover	640-000-016WT	●	●
190	Inspection Glass	640-000-015WT	●	●
200	Kit - Natural Gas Conversion	640-000-022WT	●	—
		640-000-023WT	—	●
210	Kit - Liquefied Petroleum (Propane) Gas Conversion	640-000-024WT	●	—
		640-000-025WT	—	●
220	Gas Valve VK8205V	640-000-037WT	●	●
230	Water Pressure Switch	640-000-019WT	●	●
240	CH Temperature Probe DP	640-000-034WT	●	●
250	CH Temperature Probe US	640-000-035WT	●	●
260	Relief Valve 3/4"	640-000-038WT	●	●
270	NPT Adapters	640-000-039WT	●	●
280	Gasket Set	640-000-055WT	●	●
290	Condensate Drain Trap	640-000-073WT	●	●
300	Vent Adapters (2 adapters in kit)	640-000-107WT	●	●
310	Gaskets - Vent Adapter (2 gaskets in kit)	640-000-108WT	●	●
320	Wall Mount Bracket	640-000-044WT	●	●
330	Outdoor Temperature Sensor	640-000-043WT	●	●
340	CH - Flow Pipe	640-000-074WT	●	—
		640-000-075WT	—	●
350	CH - Return Pipe	640-000-076WT	●	●
360	Gas Pipe	640-000-072WT	●	●

34 Replacement parts *(continued)*

Figure 159 Boiler replacement kits and parts FreeStyle® 80/120 (Heating Only) *continued*



W-T-156

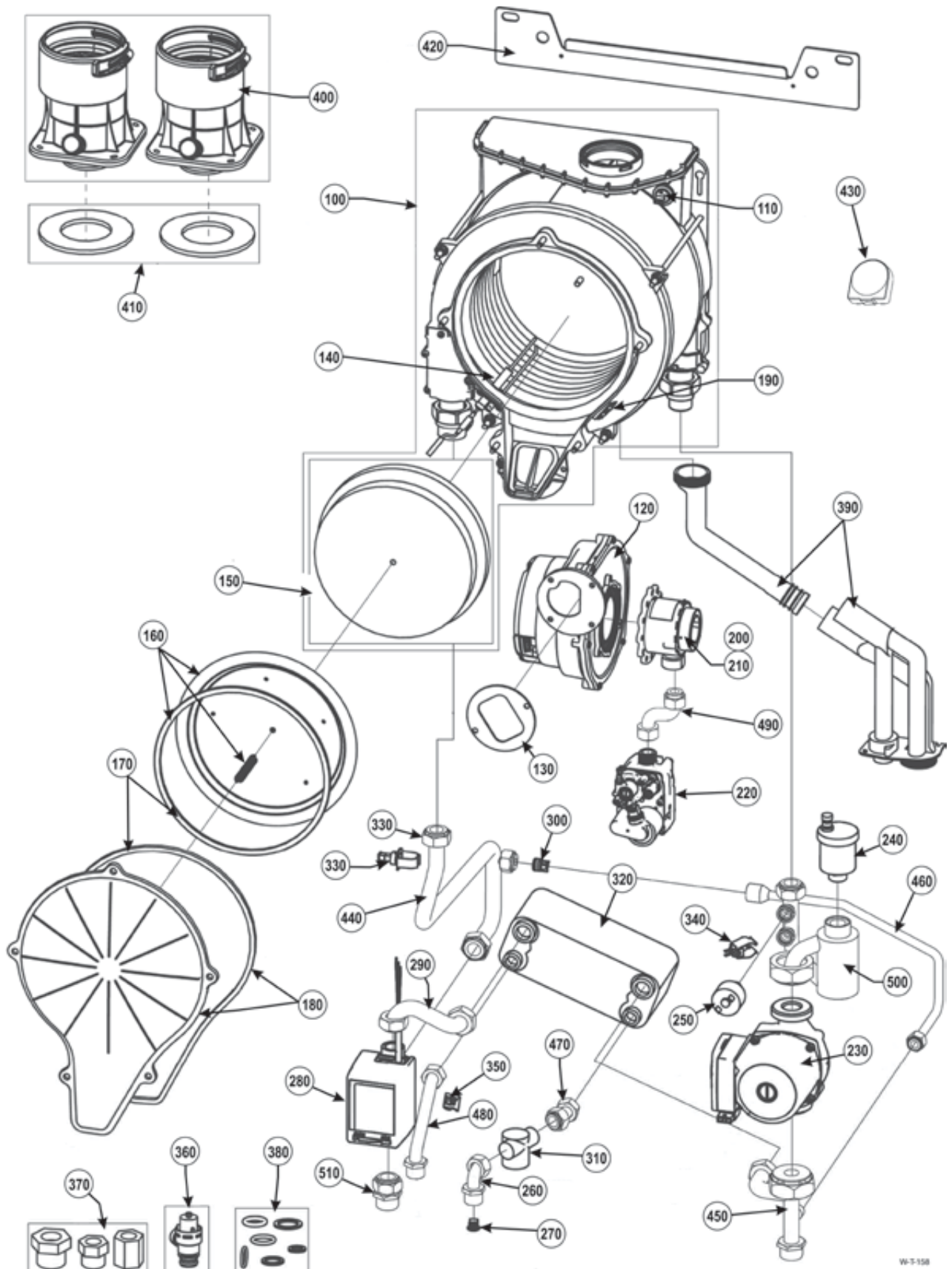
34 Replacement parts *(continued)*

Figure 160 Boiler replacement kits and parts FreeStyle® 155 (Combi)

Item	Name	Part Number
100	Heat Exchanger	640-000-080WT
110	Flue Sensor Temperature	640-000-011WT
120	Blower Assembly	640-000-081WT
130	Blower Gasket	640-000-021WT
140	Ignitor	640-000-109WT
150	Central Heat Exchanger Insulation	640-000-010WT
160	Burner	640-000-012WT
170	Burner Gasket Set	640-000-013WT
180	Burner Cover	640-000-016WT
190	Inspection Glass	640-000-015WT
200	Kit - Natural Gas Conversion	640-000-082WT
210	Kit - Liquefied Petroleum (Propane) Gas Conversion	640-000-083WT
220	Gas Valve VK8205V	640-000-037WT
230	Circulator UPS2578	640-000-086WT
240	Air Separator	640-000-087WT
250	Water Pressure Switch	640-000-019WT
260	DHW Inlet Pipe	640-000-098WT
270	Water Filter	640-000-027WT
280	Valve 3- Way	640-000-088WT
290	3-Way Valve-PHE Pipe	640-000-095WT
300	N/R Valve Fitting	640-000-030WT
310	Flow Meter	640-000-084WT
320	Plate Exchanger PFH30	640-000-089WT
330	CH Temperature Probe DP	640-000-034WT
340	CH Temperature Probe US	640-000-035WT
350	DHW Temperature Probe US	640-000-036WT
360	Relief Valve 3/4"	640-000-038WT
370	NPT Adapters	640-000-090WT
380	Gasket Set	640-000-101WT
390	Condensate Drain Trap	640-000-073WT
400	Vent Adapters (2 adapters in kit)	640-000-107WT
410	Gaskets - Vent Adapter (2 gaskets in kit)	640-000-108WT
420	Wall Mount Bracket	640-000-044WT
430	Outdoor Temperature Sensor	640-000-043WT
440	Heat Exchanger Flow Pipe	640-000-091WT
450	CH - Return Pipe	640-000-097WT
460	Bypass Pipe	640-000-093WT
470	Flow Meter PHE Pipe	640-000-099WT
480	DHW Outlet Pipe	640-000-096WT
490	Gas Pipe	640-000-100WT
500	Heat Exchanger Return pipe	640-000-092WT
510	CH Flow Pipe	640-000-094WT

34 Replacement parts *(continued)*

Figure 161 Boiler replacement kits and parts FreeStyle® 155 (Combi) *continued*



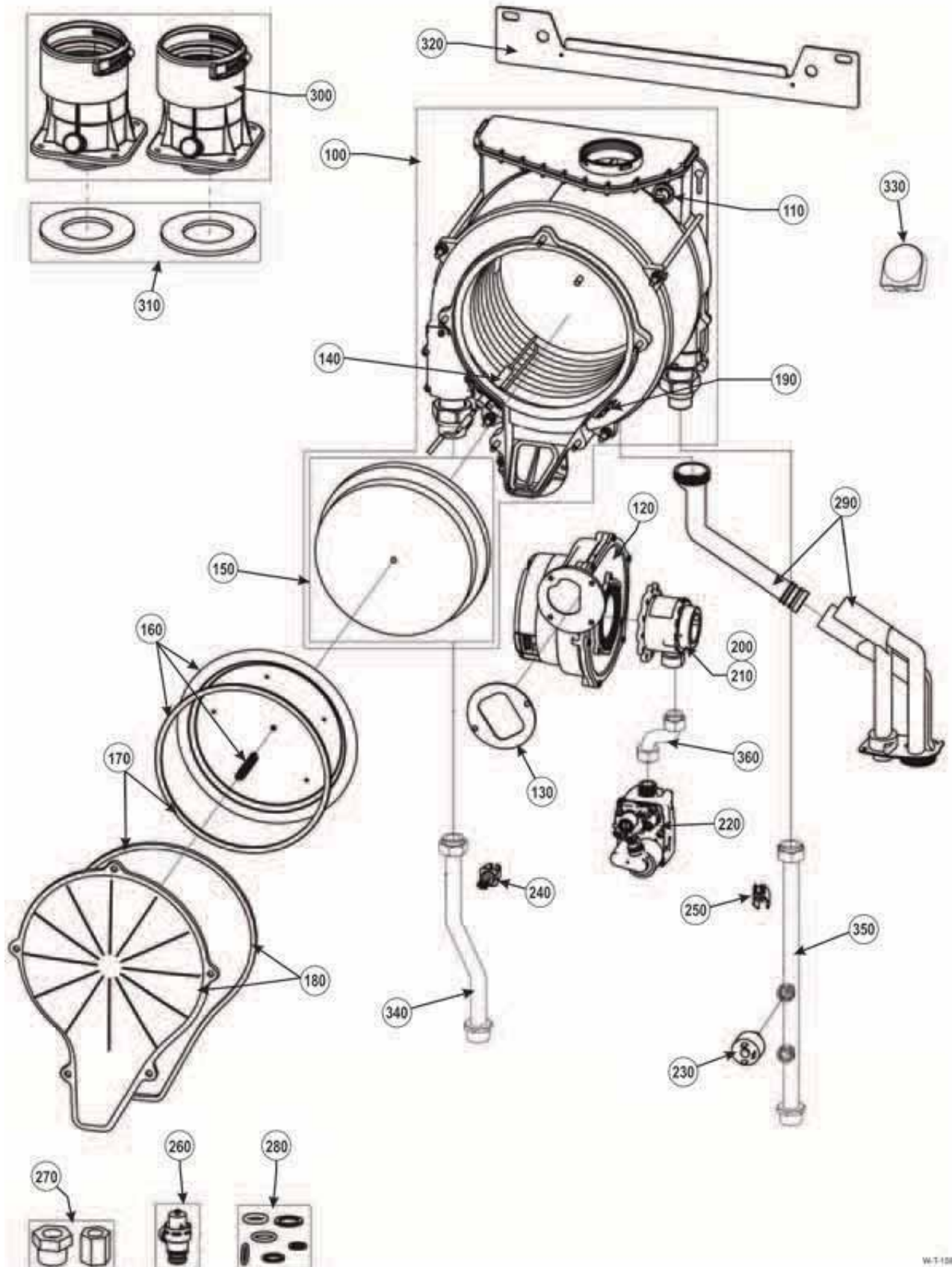
34 Replacement parts *(continued)*

Figure 162 Boiler replacement kits and parts FreeStyle® 155 (Heating Only)

Item	Name	Part Number
100	Heat Exchanger	640-000-080WT
110	Flue Sensor Temperature	640-000-011WT
120	Blower Assembly	640-000-081WT
130	Blower Gasket	640-000-021WT
140	Ignitor	640-000-109WT
150	Central Heat Exchanger Insulation	640-000-010WT
160	Burner	640-000-012WT
170	Burner Gasket Set	640-000-013WT
180	Burner Cover	640-000-016WT
190	Inspection Glass	640-000-015WT
200	Kit - Natural Gas Conversion	640-000-082WT
210	Kit - Liquefied Petroleum (Propane) Gas Conversion	640-000-083WT
220	Gas Valve VK8205V	640-000-037WT
230	Water Pressure Switch	640-000-019WT
240	CH Temperature Probe DP	640-000-034WT
250	CH Temperature Probe US	640-000-035WT
260	Relief Valve 3/4"	640-000-038WT
270	NPT Adapters	640-000-104WT
280	Gasket Set	640-000-102WT
290	Condensate Drain Trap	640-000-073WT
300	Vent Adapters (2 adapters in kit)	640-000-107WT
310	Gaskets - Vent Adapter (2 gaskets in kit)	640-000-108WT
320	Wall Mount Bracket	640-000-044WT
330	Outdoor Temperature Sensor	640-000-043WT
340	CH - Flow Pipe	640-000-106WT
350	CH - Return Pipe	640-000-105WT
360	Gas Pipe	640-000-100WT

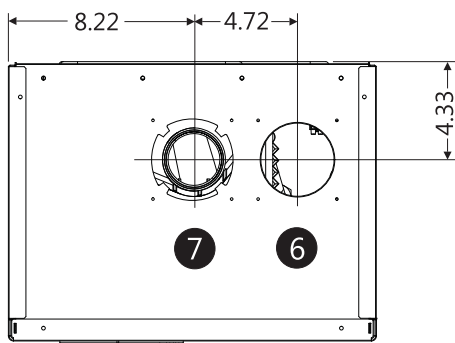
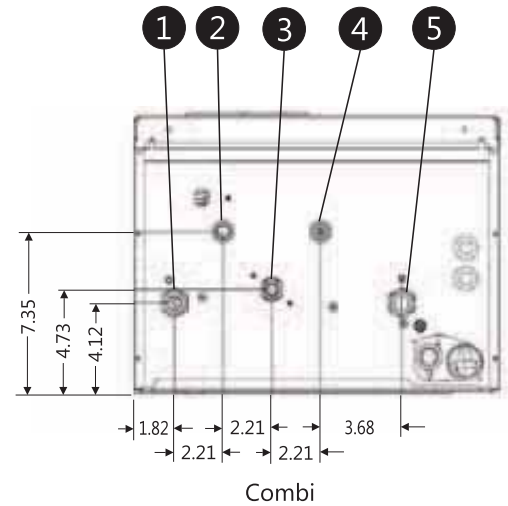
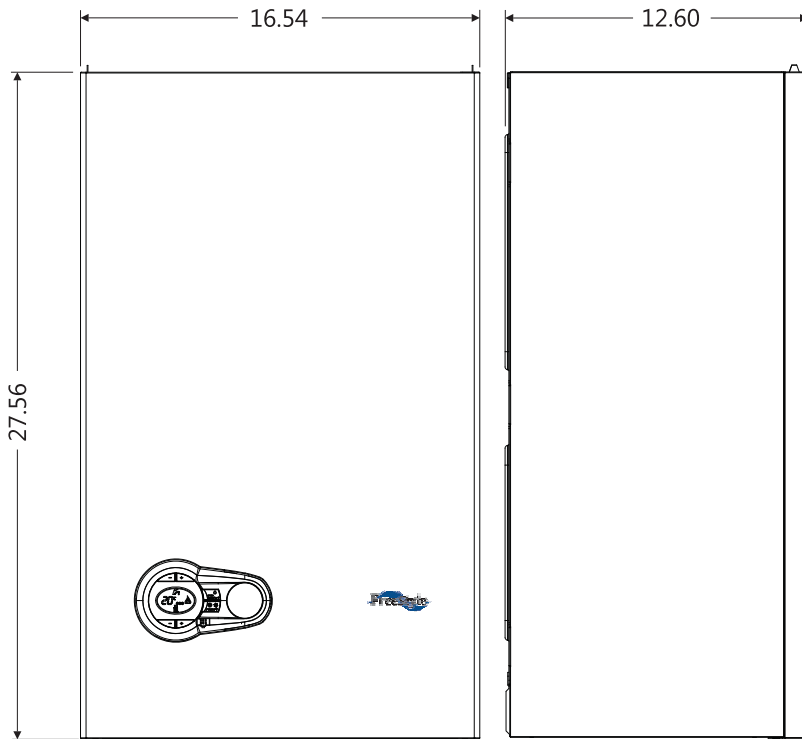
34 Replacement parts *(continued)*

Figure 163 Boiler replacement kits and parts FreeStyle® 155 (Heating Only) *continued*

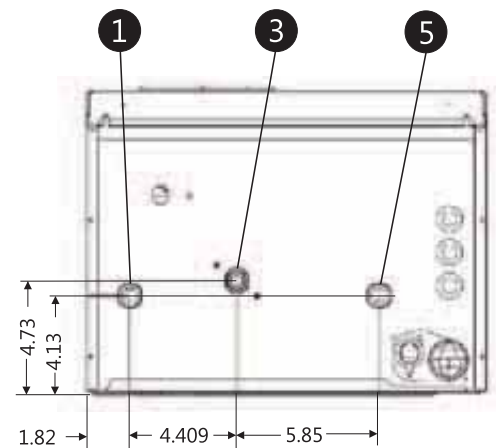


35 Dimensions and connections data

Figure 164 Dimensions and connections data — FreeStyle® 80/120 (all dimensions in inches)



Top



Heating Only

COMBI Connections

- 1 Heating system supply tapping: 3/4" NPT
- 2 Domestic hot water outlet: 1/2" NPT
- 3 Gas connection: 1/2" NPT
- 4 Cold water supply: 1/2" NPT
- 5 Heating system return tapping: 3/4" NPT
- 6 Air connection: 3" PVC, PP*, AL 29-4C SS
- 7 Flue connection: 3" PVC, PP*, AL 29-4C SS

Heating only Connections

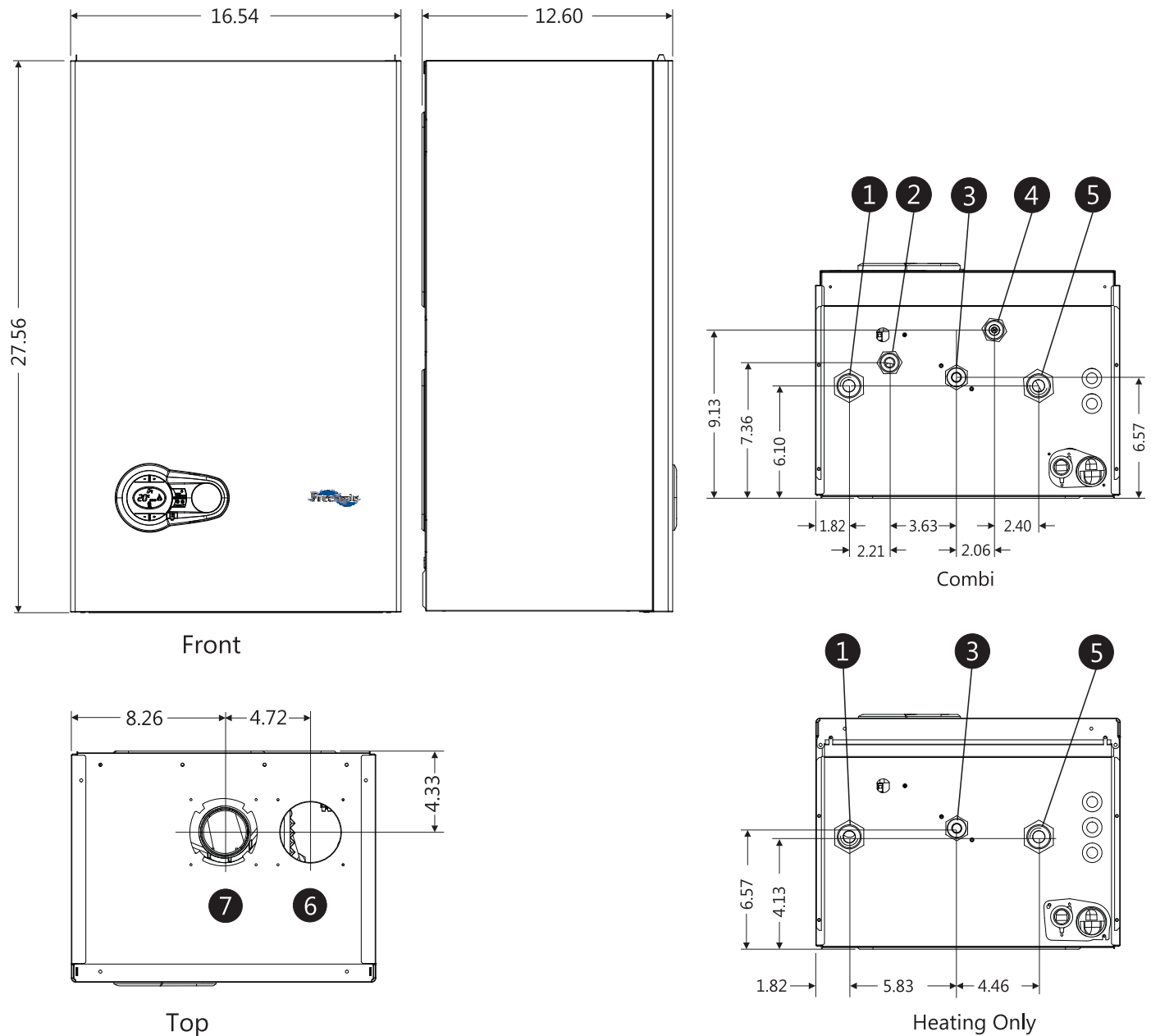
- 1 Heating system supply tapping: 3/4" NPT
- 3 Gas connection: 1/2" NPT
- 5 Heating system return tapping: 3/4" NPT
- 6 Air connection: 3" PVC, PP*, AL 29-4C SS
- 7 Flue connection: 3" PVC, PP*, AL 29-4C SS

* - Fits Simpson-Duravent PP

W-T-3160

35 Dimensions and connections data

Figure 165 Dimensions and connections data — FreeStyle® 155 (all dimensions in inches)



COMBI Connections

- 1 Heating system supply tapping: 1" NPT
- 2 Domestic hot water outlet: 3/4" NPT
- 3 Gas connection: 1/2" NPT
- 4 Cold water supply: 3/4" NPT
- 5 Heating system return tapping: 1" NPT
- 6 Air connection: 3" PVC, PP*, AL 29-4C SS
- 7 Flue connection: 3" PVC, PP*, AL 29-4C SS

Heating only Connections

- 1 Heating system supply tapping: 1" NPT
- 3 Gas connection: 1/2" NPT
- 5 Heating system return tapping: 1" NPT
- 6 Air connection: 3" PVC, PP*, AL 29-4C SS
- 7 Flue connection: 3" PVC, PP*, AL 29-4C SS

* - Fits Simpson-Duravent PP

W-T-3162

36 Engineering Data

Figure 166 Engineering data — FreeStyle® 80/120/155 boilers

Boiler Model	Shipping weight	Operating weight	Water content	Vent/air pipe size: (Provide a separate vent for each boiler)	Electrical service required
	Pounds per boiler	Pounds per boiler Note 2	Gallons per boiler		Amps per boiler Note 1
FS-80 Combi	70	74	0.53	2" or 3"	15.0
FS-120 Combi	77	82	0.63	2" or 3"	15.0
FS-155 Combi	87	93	0.75	3"	15.0
FS-80 Heating Only	61	65	0.45	2" or 3"	15.0
FS-120 Heating Only	64	68	0.55	2" or 3"	15.0
FS-155 Heating Only	67	72	0.65	3"	15.0

Notes

1	Total amp requirement includes up to one circulator, Low Water Cutoff, 3-Way Valve not exceeding 3.0 amps total.
2	Operating weight is the total weight of the boiler, including water.
3	<p>FreeStyle® 80 or 120 vent/air pipes can be either 2" or 3" pipe. FreeStyle® 155 is 3" only.</p> <p>All of the boilers will automatically de-rate as vent/air pipe length increases, due to the pressure loss through the piping. See Figure 167, page 127 for details.</p> <p>All FreeStyle® installations require a separate vent pipe and termination for each boiler. Vent piping cannot be manifolded. Install and terminate vents as described in vent/air installation instructions in this manual.</p> <p>Combustion air piping can be individually piped. See venting section in this manual.</p>

37 Ratings

Figure 167 Ratings and engineering data —FreeStyle® 80/120/155



* Low Lead Content
(Note 7)

AHRI Certified Ratings

Boiler Model	Input	Heating Capacity	Seasonal Efficiency	Net Water Rating	% Input derate vs vent length (Values shown are at MAX vent/air pipe length — See Note 6)				Vent/ Comb. Air Connection Diameter
					Direct Vent Category ONLY				
					Natural gas		Propane		
Btuh (Note 5)	Btuh (Note 2)	AFUE, % (Note 1)	Btuh (Note 3)	2" Vent/air piping	3" Vent/air piping	2" Vent/air piping	3" Vent/air piping	Inches (Note 4)	
FS-80	80,000	73,000	92.4	63,000	12 %	4.2 %	12 %	4.2 %	3" PVC/PP/SS
FS-120	120,000	109,000	92.2	94,000	11.4 %	3.5 %	11.4 %	3.5 %	3" PVC/PP/SS
FS-155	155,000	143,000	94.4	124,000	----	5.0 %	----	5.0 %	3" PVC/PP/SS

Notes

- As an Energy Star Partner, Williamson-ThermoFlo has determined that FreeStyle® boilers meet the Energy Star guidelines for energy efficiency. NOTE: Adjusting boiler firing rate will affect AFUE rating.
- Based on standard test procedures prescribed by the United States Department of Energy. NOTE that only Heating Capacity and AFUE are certified by AHRI. AFUE is also known as Annual Fuel Utilization Efficiency or Seasonal Efficiency.
- Net ratings are based on net installed radiation of sufficient quantity for the requirements of the building and nothing need be added for normal piping and pickup. Ratings are based on a piping and pickup allowance of 1.15. An additional allowance should be made for unusual piping and pickup loads.
- FreeStyle® boilers must be direct-vented. FreeStyle® boilers require special venting. Use only the vent materials and methods specified in this manual. FreeStyle® 80 or 120 vent/air pipes can be either 2" or 3". FreeStyle® 155 is 3" only. All vent and air pipe elbows must be sweep elbows, NOT short-radius elbows.
- Ratings shown are for sea level applications only. For altitudes from sea level to 4,500 feet above sea level, please refer to page 66. All of the boilers will automatically de-rate as vent/air pipe length increases, due to the pressure loss through the piping. For vent/air pipe lengths less than the maximum, the derate equals the value above times vent length ÷ 100.
- CSA - Low Lead Content only applies to the Combi boiler models.

**THE OUTDOOR SENSOR (SUPPLIED WITH HEATING ONLY BOILERS) THE BOILER MUST BE INSTALLED UNLESS EXEMPTED BELOW:
(Is optional for Combi Boilers)**

IMPORTANT

In accordance with Section 303 of the 2007 Energy Act, this boiler is equipped with a feature that saves energy by reducing the boiler water temperature as the heating load decreases. This feature is equipped with an override which is provided primarily to permit the use of an external energy management system that serves the same function.

THIS OVERRIDE MUST NOT BE USED UNLESS AT LEAST ONE OF THE FOLLOWING CONDITIONS IS TRUE:

- An external energy management system is installed that reduces the boiler water temperature as the heating load decreases.
- This boiler is not used for any space heating.
- This boiler is part of a modular or multiple boiler system having a total input of 300,000 BTU/hr or greater.
- This boiler is equipped with a tankless coil (not applicable to Combi).

38 Installation and Service Certificate

Boiler Start-Up Data			
Boiler Model / Series	FreeStyle® _____ / Series _____	Date installed _____	CO ₂ @: High fire _____% Low fire _____%
Part Number _____	FUEL: Natural _____ LP _____	Btu Input _____	CO @: High fire _____ ppm Low fire _____ ppm
Natural gas input rate measured HIGH _____ CFH / LOW _____ CFH			

Installation and service certificate

Boiler model _____ Series _____

Number _____ Date installed _____

Measured Btuh input _____

- Installation instructions have been followed.
- Checkout sequence has been performed.
- Above information is certified to be correct.
- Information received and left with owner/maintenance person.

Installer _____ (company) _____ (address) _____ (phone)

(installer's signature)