

ENCLOSED MODEL

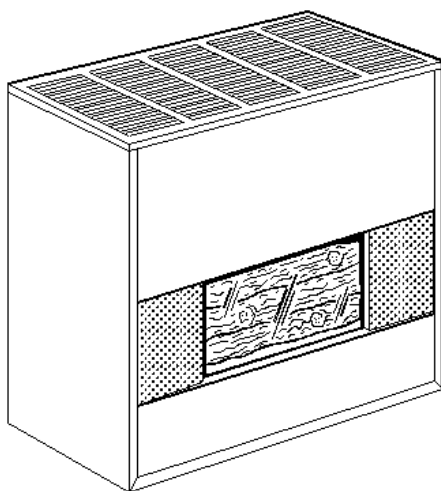

FIREPLACE MODEL



**WARNING:** Improper installation, adjustment, alteration, service or maintenance can cause injury or property damage. Refer to this manual. For assistance or for additional information consult a qualified installer, service agency or the gas supplier.

## Vented Room Heaters

### Model Numbers:

2001622A; 2011622A; 2031622A; 2051622A; 3501522A; 3511522A;  
3531522A; 3551522A; 3501922A; 3511922A; 3531922A; 3551922A;  
3502522A; 3511522A; 3532522A; 3552522A; 3502922A; 3512922A;  
3532922A; 3552922A; 5001522A; 5011522A; 5031522A; 5051522A;  
5001922A; 5011922A; 5031922A; 5051922A; 5002522A; 5012522A;  
5032522A; 5052522A; 5002922A; 5012922A; 5032922A; 5052922A;  
6501522A; 6511522A; 6531522A; 6551522A; 6501922A; 6511922A;  
6531922A; 6551922A; 6502522A; 6512522A; 6532522A; 6552522A;  
6502922A; 6512922A; 6532922A; 6552922A

FOR USE WITH NATURAL GAS ONLY

### Model Numbers:

2001621A; 2011621A; 2031621A; 2051621A; 3501521A; 3511521A;  
3531521A; 3551521A; 3501921A; 3511921A; 3531921A; 3551921A;  
3502521A; 3512521A; 3532521A; 3552521A; 3502921A; 3512921A;  
3532921A; 3552921A; 5001521A; 5011521A; 5031521A; 5051521A;  
5001921A; 5011921A; 5031921A; 5051921A; 5002521A; 5012521A;  
5032521A; 5052521A; 5002921A; 5012921A; 5032921A; 5052921A;  
6501521A; 6511521A; 6531521A; 6551521A; 6501921A; 6511921A;  
6531921A; 6551921A; 6502521A; 6512521A; 6532521A; 6552521A;  
6502921A; 6512921A; 6532921A; 6552921A

FOR USE WITH LIQUEFIED PETROLEUM (L.P.) GAS ONLY

READ THIS OWNER'S MANUAL CAREFULLY BEFORE YOU INSTALL YOUR NEW WILLIAMS HEATER.

**WARNING:** If the information in these instructions is not followed exactly, a fire or explosion may result causing property damage, personal injury or loss of life.

- Do not store or use gasoline or other flammable vapors and liquids in the vicinity of this or any other appliance.
- **WHAT TO DO IF YOU SMELL GAS:**
  - Open all windows.
  - Do not try to light any appliance.
  - Do not touch any electrical switch; do not use any phone or cell phone in your building.
  - Extinguish any open flame.
  - Immediately call your gas supplier from a neighbor's phone. Follow the gas supplier's instructions.
  - If you cannot reach the gas supplier, call the fire department.
- Installation and service must be performed by a qualified installer, service agency or the gas supplier.

**WARNING:** Installation and repair must be done by a qualified service person. The appliance should be inspected before use and at least annually by a professional service person.

# Warranty

The manufacturer, Williams Furnace Co., warrants this wall furnace or heater to the original purchaser under the following conditions:

## LIMITED ONE-YEAR WARRANTY

1. Any part thereof which proves to be defective in material or workmanship within one year from date of original purchase for use will be replaced at the Manufacturer's option, FOB to its factory.
2. No liability is assumed by the Manufacturer for removal or installation labor costs, nor for freight or delivery charges.

## LIMITED EXTENDED WARRANTY

1. In addition to the above limited one-year warranty on the complete unit, any combustion chamber which burns out or rusts under normal installation, use and service conditions during a period of nine years following expiration of the one-year warranty period will be exchanged for a like or functionally similar part.
2. No liability is assumed by the Manufacturer for removal or installation labor costs, nor for freight or delivery charges.

## LIMITATIONS

1. THIS LIMITED WARRANTY IS THE ONLY WARRANTY MADE BY THE MANUFACTURER, IMPLIED WARRANTIES OF MERCHANTABILITY OR FITNESS FOR ANY PARTICULAR PURPOSE ARE LIMITED TO THE SAME ONE YEAR TERM AS THE EXPRESS WARRANTY. UNDER NO CIRCUMSTANCES SHALL THE MANUFACTURER BE LIABLE FOR INCIDENTAL, CONSEQUENTIAL, SPECIAL OR CONTINGENT DAMAGES OR EXPENSES ARISING DIRECTLY OR INDIRECTLY FROM ANY DEFECT IN THE PRODUCT OR ANY COMPONENT OR FROM THE USE THEREOF. THE REMEDIES SET FORTH HEREIN ARE THE EXCLUSIVE REMEDIES AVAILABLE TO THE USER AND ARE IN LIEU OF ALL OTHER REMEDIES.

Some states do not allow limitation on how long an implied warranty lasts, and some states do not allow the exclusion or limitation of incidental or consequential damages, so the above limitations or exclusions may not apply to you.

2. This warranty does not include any charge for labor or installation.
3. This warranty does not extend to painted surfaces or to damage or defects resulting from accident, alteration, misuses or abuse or improper installation.
4. This warranty does not cover claims which do not involve defective workmanship or materials.

## DUTIES OF THE CONSUMER

1. The heating equipment must be installed by a qualified installer and operated in accordance with the installation and homeowner's instructions furnished with the equipment.
2. Any travel, diagnostic costs, service labor, and labor to repair the defective unit will be the responsibility of the owner.
3. A bill of sale, cancelled check, payment record or permit should be kept to verify purchase date to establish the warranty period.
4. Have the installer enter the requested information in the space below.

## GENERAL

1. The manufacturer neither assumes nor authorizes any person to assume for it any other obligation or liability in connection with said equipment.
2. Service under this warranty should be obtained by contacting your dealer. Provide the dealer with the model number, serial number, and purchase date verification.
3. If, within a reasonable time after contacting your dealer, satisfactory service has not been received, contact: Customer Service Department, 250 West Laurel Street, Colton, CA 92324 for assistance.
4. THIS WARRANTY GIVES YOU SPECIFIC LEGAL RIGHTS AND YOU MAY ALSO HAVE OTHER RIGHTS WHICH VARY FROM STATE TO STATE.

# Installation Record

Model No. \_\_\_\_\_ Serial No. \_\_\_\_\_

Original Purchaser \_\_\_\_\_

Address \_\_\_\_\_

City and State \_\_\_\_\_ Zip \_\_\_\_\_

Dealer \_\_\_\_\_

Address \_\_\_\_\_

City and State \_\_\_\_\_ Zip \_\_\_\_\_

Installation Date \_\_\_\_\_ Name \_\_\_\_\_ Signature \_\_\_\_\_

(Dealer or authorized representative who certifies that this appliance is installed in accordance with Manufacturer's instructions and local codes.)

# Contents

Your Williams Warranty.....	2	Quick Reference: Here's how to...	
Installation Record.....	2	Unpack the heater.....	5
Table of Contents.....	3	Learn how to unpack the new Williams Heater and verify that all its parts are in working order.	
Safety Rules.....	4	Install the heater.....	6-15
Introduction.....	5	Thermostat and Vent Installation is all explained starting on page 8 thru 11.	
Basic Description.....	5	Operate the heater.....	16-18
Basic Tools Needed.....	5	Igniting the heater for the first time.	
Basic Materials Needed.....	5	Caring for Your Heater.....	19-20
Optional Accessories.....	5	Learn how to keep your new Williams Heater operating.	
Unpack Your Heater.....	5		
Installing Your Heater.....	6-15		
Locating the Heater.....	6-8		
Combustion & Ventilation Air.....	8-11		
Thermostat Installation.....	11-12		
Vent Installation.....	13-15		
Operating Your Heater.....	16-18		
Start Up Procedure.....	16-17		
Gas Conversion Kits.....	17		
Operating Instructions.....	18		
How To Care For Your Heater.....	19-20		
Repair Parts & Parts Lists.....	21-26		
Blower Accessory 2102.....	27-28		
Troubleshooting Chart.....	29-31		
SERVICE HINTS.....	Back Cover		
How To Order Repair Parts.....	Back Cover		

# Safety Rules

**WARNING:** Read these rules and the instructions carefully. Failure to follow these rules and instructions could cause a malfunction of the heater. This could result in death, serious bodily injury and/or property damage.

INSTALLATION MUST CONFORM TO LOCAL CODES. IN THE ABSENCE OF LOCAL CODES, INSTALLATION MUST CONFORM TO THE NATIONAL FUEL GAS CODE, ANSI Z223.1. THE APPLIANCE, WHEN INSTALLED MUST BE ELECTRICALLY CONNECTED AND GROUNDED IN ACCORDANCE WITH LOCAL CODES OR, IN THE ABSENCE OF LOCAL CODES, WITH THE CURRENT NATIONAL ELECTRICAL CODE ANSI/NFPA NO. 70.

## In Canada:

1. Installation must conform to local codes or, in the absence of local codes, the current CAN/CGA B149 installation code.
2. The appliance, when installed, must be electrically connected and grounded in accordance with local codes or, in the absence of local codes, with the current CSA C22.1 Canadian Electrical code.
3. Field conversions for high altitude are not permitted in Canada.
4. Reference is made in this manual regarding gas type as L.P.G. Be advised that L.P.G. is not available in Canada, refer to propane/L.P. Gas.

1. Use only manufacturer's replacement parts. Use of any other parts could cause injury or death.
2. DO NOT install the heater in an alcove.
3. DO NOT install this heater where it could be isolated by closing doors to the heated space.
4. DO NOT install this heater in a travel trailer or recreational vehicle.
5. MAINTAIN all clearances specified in section "Locating Wall heater and Thermostat" and "Vent Installation."
6. BE SURE this heater is for the type of gas to be used. Check the rating plate by the gas valve in the lower cabinet. Do not change it to use other gases without the proper manufacturer's Gas Conversion Kit.
7. For natural gas, the minimum inlet gas supply pressure for the purpose of input adjustment is 5" water column. The maximum inlet gas supply pressure is 7" water column.  
For L.P. Gas, the minimum inlet gas supply pressure for the purpose of input adjustment is 11" water column. The maximum inlet gas supply pressure is 13" water column.
8. Any safety screen, guard or parts removed for servicing this appliance must be replaced prior to operating the appliance to avoid property damage, bodily injury or death.

9. Install the heater vent directly to the outdoors, so that harmful gases will not collect inside the building. Follow the venting instructions for your type of installation exactly. Use only the type and size of vent pipe and fittings specified.
10. BE SURE to provide for adequate combustion and ventilation air. The flow of this air to the heater must not be blocked.
11. NEVER vent flue gases into another room, a fireplace or any space inside a building. This could cause property damage, bodily injury or death.
12. Never test for gas leaks with an open flame. Use a soap solution to check all gas connections. This will avoid the possibility of fire or explosion.
13. ALLOW the heater to cool before servicing. Always shut off electricity and gas to the heater when working on it. This will prevent any electrical shocks or burns.
14. DUE TO HIGH TEMPERATURES, locate the heater out of traffic and away from furniture and draperies.
15. ALERT children and adults to the hazards of high surface temperatures and warn them to keep away to avoid burns or clothing ignition.
16. CAREFULLY supervise young children when they are in the same room with the heater.
17. DO NOT place clothing or other flammable material on or near heater.
18. INSTALLATION and REPAIR must be done by a qualified service person. The appliance should be inspected before use and at least annually by a professional service person. More frequent cleaning may be required due to excessive lint from carpeting, bedding material, etc. It is important that control compartments, burners and circulating air passages be kept clean. Failure to keep burner-control compartment and other parts of heater clean can cause dangerous conditions to develop which can cause injury and even death.
19. BEFORE INSTALLING the optional blower: To avoid electrical shock, turn off electrical circuits that pass through the wall where you are going to install the heater.
20. BE AWARE of good safety practices by wearing personal protective equipment such as gloves and safety glasses to avoid being injured by sharp metal edges in or around heater and while cutting or drilling holes in wood and/or sheet metal.
21. CAUTION: Label all wires prior to disconnection when servicing controls. Wiring errors can cause improper and dangerous operation. Verify proper operation after servicing.
22. DO NOT store or use gasoline or other flammable liquids or vapors near the heater.

**WARNING:** Do not use this heater if any part has been under water. Immediately call a certified service technician to inspect the heater and to replace any part of the control system and any gas control which has been under water.

# Introduction

---

Please read our instructions before you install and use your heater. This will help you obtain the full value from this heater. If the answer to the problem is found within this instruction manual, it could help you avoid needless service costs.

## Basic Description

---

Always consult your local heating or plumbing inspector, building department or gas company regarding regulations, codes or ordinances which apply to the installation of a vented room heater.

No electrical power is required unless furnace is equipped with an optional blower accessory.

The efficiency rating of this appliance is a product thermal efficiency rating determined under continuous operating conditions and was determined independently of any installation system.

Warmed air is discharged into the room in which the heater is located. The heater contains a single multi-slot gas burner.

Combustion air is drawn in from the room where the heater is located and is vented out of the heater vertically through vent piping to a roof vent top. (Vent equipment is not supplied with the heater).

The combustion chamber is built of heavy-gauge steel. The heater cabinet is also constructed of heavy-gauge steel and has a powder-coat paint finish.

The heater controls are located behind an access door on the side of the heater. All models are equipped with CSA/AGA listed gas valves and pilots.

The appliance is equipped with a vent safety shutoff system, designed to protect against improper venting. Operation of this room heater when not connected to a properly installed and maintained venting system or tampering with the vent safety shutoff system can result in carbon monoxide (CO) poisoning and possible death.

This heater is design certified in accordance with American National Standard & CSA Standard Z21.86 and CSA 2.32 as a vented room heater and must be installed according to these instructions.

## Basic Tools Needed

---

Hand drill or properly grounded electric drill  
1/8 inch and 3/16 inch drill bit (metal)  
6 foot folding ruler or tape measure  
Screwdriver (Phillips Head)  
Pliers (Wire Cutting)  
Hammer

Stud locator or small finishing nails  
8 inch adjustable wrench  
Keyhole saw or saber saw  
2-10 inch or 12 inch pipe wrenches  
Gloves and safety glasses

## Basic Materials Needed

---

Pipe joint compound resistant to L.P. gases.  
Electrical wiring supplied as needed for optional blower.

Pipe and fittings to make connections to the heater.

## Helpful Installation Information

---

The following booklets will help you in making the installation:

ANSI/NFPA 70-1990 or current edition "National Electrical Code". In Canada: CSA C22.1 Canadian Electrical Code.

American National Standard NFPA54/ANSI Z223.1 1988 or current edition "National Fuel Gas Code".

Obtained from: American National Standards Institute, Inc., 1430 Broadway, New York, N Y 10018.

In Canada: CAN/CGA B149.

## Optional Accessories

---

### Blower

To increase circulation of warmed air within the heated space, you may use Blower Accessory Kit 2102, on all models except 2001622A and 2001621A.

### Thermostat P322016

### Floor Board Model 4163 or 4167

Available in black to match the heater.

### Vent Collar Model 9102, 9104 or 9106

Available in black to match the heater.

## Unpack Your Heater

---

Examine all packing material carefully. Look for loose parts before discarding. Store all parts where they cannot be lost or damaged before you need them.

**NOTE:** Check the burner rating plate, located in the burner compartment, to make sure your heater is equipped to operate on the type of gas available (either natural or L.P. Gas). DO NOT

convert unit from natural gas to L.P. Gas or from L.P. Gas to natural gas without the proper manufacturer's gas conversion kit.

# Installing Your Heater

The following steps are needed for proper installation and safe operation of your heater. If you have any doubts as to any requirements, check with local authorities for local and state codes affecting the installation.

Obtain professional help where needed.

**DO NOT** install this heater in a travel trailer, recreational vehicle, or mobile home.

## Locating the Heater

**WARNING:** Gas burning appliances require air for combustion and proper venting. Minimum fresh air opening of 1 square inch per 1,000 Btu/hr. input rating must be provided for ventilation.

EXAMPLE: A 30,000 Btu/hr. input unit requires the equivalent of a 30 inch wide window be open 1 inch for safe operation.

**WARNING:** Danger of property damage, bodily injury or death. Even when a house meets requirements for unconfined space with adequate air infiltration, it is recommended that a fresh air intake be installed to lessen the possible dangers from any future changes on the home.

Consider the following points before attempting to install the heater:

- In choosing the location for the heater, the following factors should be considered:
  - Convenience to the gas supply.
  - Arrangement of the rooms or area to be heated.
  - Probable location of the furniture.
  - General appearance.
  - Safe clearance from anything that could catch fire.
  - Ability to properly vent the heater.
- Locate the heater centrally in the area which it is to heat. The ideal location is at the source of cold air, which is an outside wall. If the heater is on an outside wall, the cold air will be warmed before it moves through the room.
- Place the heater where the air will circulate freely throughout the area to be heated. If one heater is intended to heat the entire house, it is advisable to consider the installation of grilles immediately below the ceilings to permit circulation of hot air from room to room. Return air grilles are also desirable.
- Be certain the heater is placed where the air is free to circulate around it. Never install the heater in a wall recess. The minimum clearance required to any wall or object can be found on the rating plate located inside the heater control door on the base plate. We recommend a 24-inch min. clearance from the burner access door for the ease of lighting and for observation of pilot and burner flames.
- The heater must be installed so that the draft hood is in the same pressure zone as the combustion air.
- The heater may be placed directly on wood floors. Heavy pile or shag rugs may restrict normal air flow. Some floor coverings discolor easily from even low heat. To assure safe

## IMPORTANT

For satisfactory and trouble-free operation, be sure to:

- Locate the heater properly within the space to be heated.
- Provide for adequate combustion air, adequate air circulation around the cabinet inside the open room and a proper vent system.
- Maintain all minimum clearances which apply to your heater.

operation, a metal or wood panel, extending the full depth and width of the appliance must be placed under the heater. Optional floor boards are available from Williams.

- Do not place the heater where curtains, draperies, or any other material may come into contact with any part of the heater.

## GAS CONTROLS

- All models are regulated on natural or L.P. Gases. The regulator is built into the gas control valve.
- All models are equipped with a 100% pilot safety shutoff and vent safety shutoff system.
- CAUTION:** Do not connect 115V electrical service line to gas control valve or wall thermostat.

## GAS SUPPLY

For natural gas, the minimum inlet gas supply pressure for the purpose of input adjustment is 5" water column. The Maximum inlet gas supply pressure is 7" water column.

For L.P. Gas, the minimum inlet gas supply pressure for the purpose of input adjustment is 11" water column. The maximum inlet gas supply pressure is 13" water column.

The gas pressure and input to the burners must not exceed the rated input and pressure shown on the rating plate. On Natural Gas, the manifold pressure should be 4 inches water column. The manifold pressure should be 10 inches water column for L.P. Gas.

Orifice changes may be required to suit the gas supplied.

For heaters located at elevations between sea level and 2,000 feet, the measured input must not be greater than the input shown on the rating plate of the heater. For elevations above 2,000 feet, the measured input must not exceed the input of the rating plate reduced by 4 percent for each 1,000 feet that the heater is above sea level.

## MINIMUM REQUIRED CLEARANCES

MODEL	"A" SIDE	"B" CEILING	"C" REAR
200 SERIES	2"	36"	3"
350 SERIES	6"	57"	6"
500 SERIES	6"	57"	6"
650 SERIES	6"	57"	6"

24" min. Clearance is recommended on side with burner access door for ease of lighting and for observation of pilot and burner flames.

# Installing Your Heater

**FIGURE 1 Minimum Required Clearances**

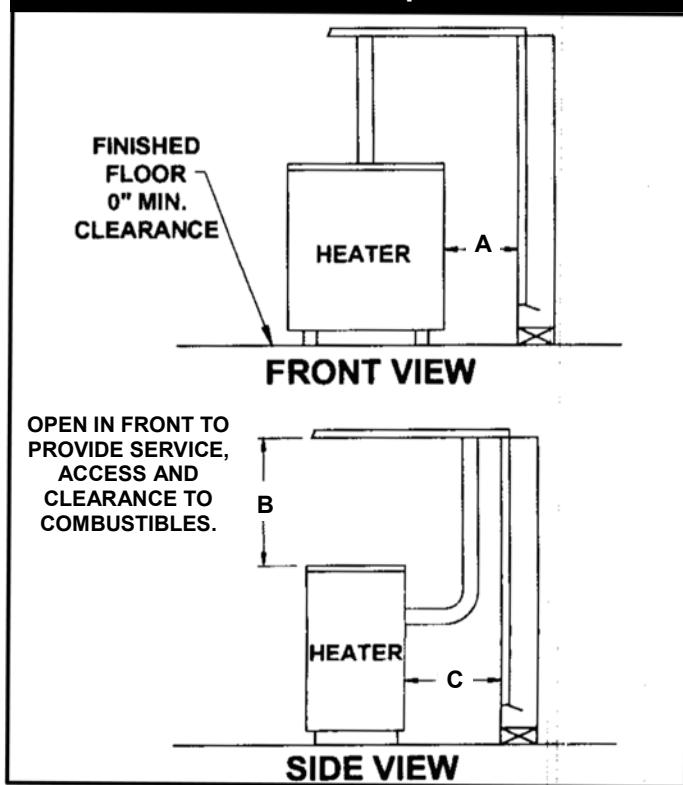

**Note:** Minimum fresh air opening is 1 square inch per 1,000 Btu/hr.

## GAS PIPING

State and local authorities have established codes regulating the installation of gas burning equipment. Consult your gas supplier or gas company for complete information. In the absence of local codes, all aspects of the installation must comply with the National Fuel Gas Code ANSI Z223.1. In Canada: Follow the CAN/CGA-B149.1(2) Canadian Standard.

1. Use ½-inch pipe or semi-rigid tubing for natural and Liquefied Petroleum Gases. **DO NOT USE FLEXIBLE HOSE.** Appliance connectors of corrugated metal tubing and fittings that are listed by a nationally recognized testing agency may be used if accepted by the local code authorities. **FOLLOW THE MANUFACTURER'S INSTALLATION INSTRUCTIONS.** This type of connection may only be installed in the room where the heater is located.
2. A manual shutoff valve and union must be installed in the gas supply line just ahead of the connection to the heater. The manual valve must include a 1/8-inch NPT plugged tapping accessible for connection of a test gauge.
3. Unions in the gas supply lines should be of the ground joint type. Compounds used on threaded pipe joints must be resistant to the action of liquefied petroleum gases.

**WARNING:** When connecting field piping, use a second wrench to keep the heater valve from turning. Support field piping properly, stress and over tightening could damage the gas valve and result in dangerous gas leaks which can cause dangerous conditions including property damage, bodily injury, and even death.

4. A drip leg (Figure 2) should be installed to constitute a trap to catch any condensate that may be in the gas. The drip leg should be readily accessible for cleaning.
5. The heater must be disconnected from the gas supply system and from the heater's individual shutoff valve when the system is tested at a pressure in excess of 1/2 PSI.
6. Check all factory and field pipe joints for gas leaks before and after lighting the heater. Use a soap solution. Never use a match or open flame. Correct any leak (s), no matter how small.
7. Piping supply shall be supported to prevent sagging damage to the controls and hazardous gas leaks. To prevent freezing where the supply pipe is exposed to cold air, wrap the pipe or run it underground.

**FIGURE 2 Left Side Gas Inlet**

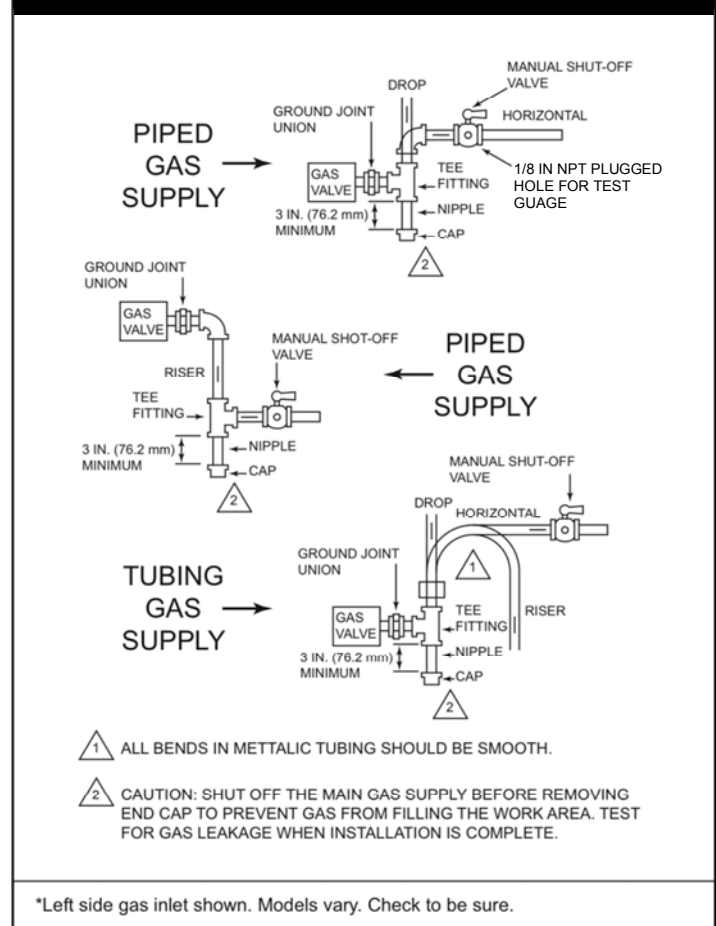

# Installing Your Heater

**FIGURE 3 Proper Piping Practice**

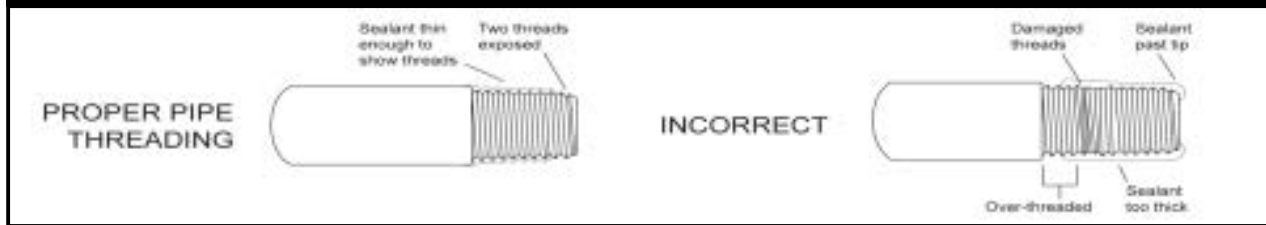

**IMPORTANT:** All piping must comply with local codes and ordinances or with the National Fuel Gas Code (ANSI Z223.1 NFPA No. 54), whichever applies. (In Canada: CAN/CGA B149).

**FIGURE 4 Enclosed Model**

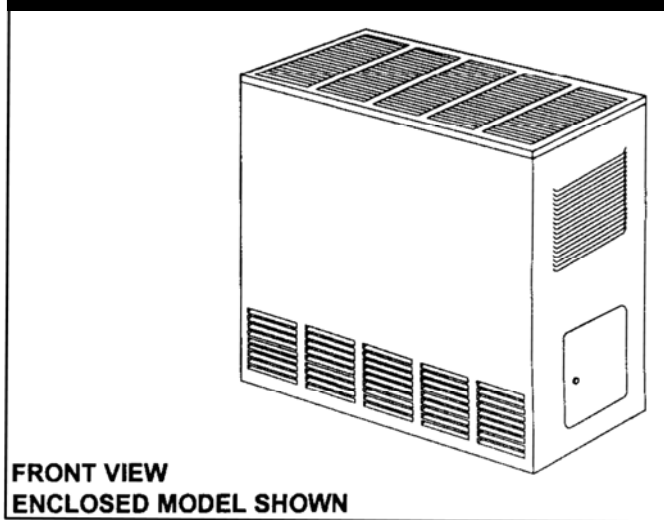

**FIGURE 5 Gas Pipe Sizes**

NATURAL GAS PIPE CAPACITY - Btu/hr. (INCLUDES FITTINGS) PIPE SIZE			
LENGTH OF PIPE - FEET	1/2 INCH	3/4 INCH	1 INCH
20	92,000	190,000	350,000
40	63,000	130,000	245,000
60	50,000	105,000	195,000
L.P. GAS PIPE CAPACITY - Btu/hr. (INCLUDES FITTINGS)			
LENGTH OF PIPE - FEET	1/2 INCH	3/4 INCH	1 INCH
20	189,000	393,000	732,000
40	129,000	267,000	504,000
60	103,000	217,000	409,000

## Combustion & Ventilation Air

**WARNING:** Danger of property damage, bodily injury or loss of life. The furnace and any other fuel-burning appliances must be provided with enough fresh air for proper combustion and ventilation of flue gases. Most homes will require that outside air be supplied into the heated area.

The high cost of energy for home heating has brought about new materials and methods used to construct or remodel most current homes. The improved construction and additional insulation has reduced the heat loss and made these homes much tighter around windows and doors so that infiltrated air is minimal. This creates a problem to supply combustion and ventilation air for gas-fired or other fuel burning appliances. Any use of appliances that pull air out of the house (clothes dryers, exhaust fans, fireplaces, etc.) increases this problem and appliances could be starving for air.

In addition, these energy measures mean that your home will retain more water vapor or a higher relative humidity.

High humidity, especially during cold weather, may be damaging to buildings because condensation forms on windows and inside walls.

The combination of a tight energy efficient home with the use of exhaust fans, fireplaces, clothes dryers, and gas appliances result in more and more air being drawn from the house until fresh air may be sucked back into the house down a furnace flue or fireplace chimney. Carbon monoxide can be the result. Carbon monoxide (CO) is a colorless, odorless gas produced when fuel is not burned completely or when the flame does not receive sufficient oxygen. Automobiles, charcoal, wood fires and improperly vented or air-starved coal, oil and gas furnaces or other appliances can produce carbon monoxide.

### Be aware of these air-starvation signals:

1. Headaches, nausea, dizziness.
2. Excessive humidity shown by heavily frosted windows or a moist "clammy" sensation.
3. Fireplace smoke fills the room or will not draw.
4. Furnace flue backs up.

# Installing Your Heater

## AIR REQUIREMENTS

The requirements for providing air for combustion and ventilation are listed in the National Fuel Gas Code NFPA 54/ANSI Z223.1 (in Canada: CAN/CGA B149). Most homes will require that outside air be supplied to the heated area by means of ventilation grilles or ducts connecting directly to the outside or spaces open to the outdoors such as attic or crawl space. The only exception is when the furnace area meets the requirements and definitions for an unconfined space with adequate air infiltration.

**WARNING:** Danger of property damage, bodily injury or loss of life. The furnace and any other fuel-burning appliances must be provided with enough fresh air for proper combustion and ventilation of flue gases. Most homes will require that outside air be supplied into the heated area.

All air openings and connecting ducts must comply with the following:

If the furnace is installed in an area with another gas appliance(s), the total input rating of all appliances must be considered when determining the free area requirements for combustion and ventilation air openings.

Ducts must have the same cross-sectional area as the free area of the openings to which they connect. The minimum dimension of rectangular air ducts must not be less than 3-inches in length or height.

## LOUVERS / GRILLES AND SCREENS COVERING FREE AREA OPENINGS

If a screen is used to cover the opening(s), it must not be smaller than 1/4-inch mesh. Use the free area of a louver or grille to determine the size opening required to provide the free area specified. If the free area is not known, assume a 20% free area for wood and a 60% free area for metal louvers or grilles.

### EXAMPLE 1

#### FURNACE LOCATED IN UNCONFINED SPACE.\*

\*An unconfined space must have a volume of a minimum 50 cubic feet per 1000 Btu/hr. of total of all appliances in area. Adjoining rooms may be included only if there are no doors between the rooms, or if special provisions are made such as ventilation grilles installed between connecting rooms.

Page 10, figure 8 shows the minimum area in square feet' based on 8 foot ceiling heights, required for different Btu/hr. input ratings.

A. If your furnace is in an open area (unconfined space\*) the air that leaks through the cracks around doors and windows may be enough for combustion and ventilation air. The doors should not fit tight. The cracks around windows should not be caulked or weather stripped.

To determine if infiltration air is adequate, perform following checks:

1. Close all doors and windows. If you have a fireplace, start a fire and wait until flames are burning vigorously.

**FIGURE 6 Draft Hood Spillage**

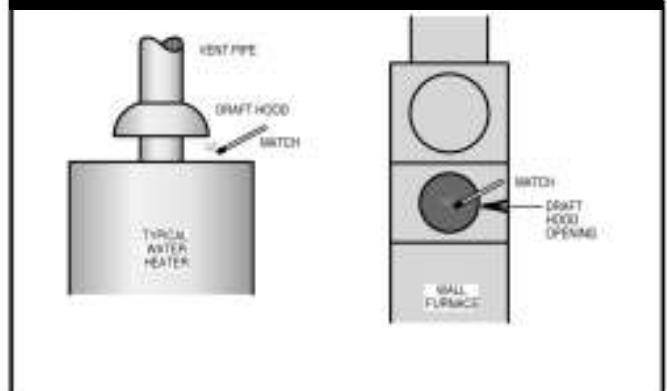

2. Turn on all exhausting devices, such as: kitchen and bathroom exhaust fans dryers (gas and electric)
  3. Turn on all vented gas appliances, such as: heating equipment (includes any room heaters) water heater
  4. Wait ten (10) minutes for drafts to stabilize.
  5. Check for draft hood spillage at each appliance. (Hold a lighted match 2 inches from draft opening. See Fig. 6.)
- B. No Spillage
- If the match flame pulls toward draft hood - this indicates sufficient infiltration air:
1. Return exhausting devices and appliances to the condition you found them.
- C. Draft Hood Spills
- If there is spillage at a draft hood (match goes out or flame wavers away from draft hood):
1. Check for plugged flue connectors and chimneys. Check and repair, stoppage and test again.
  2. If you have a fireplace, open a window or door near the fireplace and then check for spillage.
    - a) If spillage stops, do not use the fireplace without a nearby window or door open until you can supply fresh air by a permanent duct.
  3. If you have kitchen and bathroom exhaust fans, turn them off and check for spillage.
    - a) If spillage stops, do not use exhaust fans until you can supply fresh air by a permanent duct.

**WARNING:** Danger of property damage, bodily injury or loss of life. Draft hood spillage, with unobstructed vents, indicates that additional air must be brought into the structure from outside. Keep a window open (minimum 2 inches) near the appliance until a permanent air duct is installed.

# Installing Your Heater

4. Spillage means air starvation and a fresh air duct or air intakes must be installed to provide air directly to the furnace or other gas appliance.

D. If spillage exists or when the furnace is in a building of tight construction where the windows and doors are weather-stripped, air for combustion and ventilation must be obtained from outdoors or space open to the outdoors.

Provide an opening(s) having a total free area of 1-square inch per 4000 Btu/hr. for the total of all appliances. The required area is shown on page 11, Fig. 11.

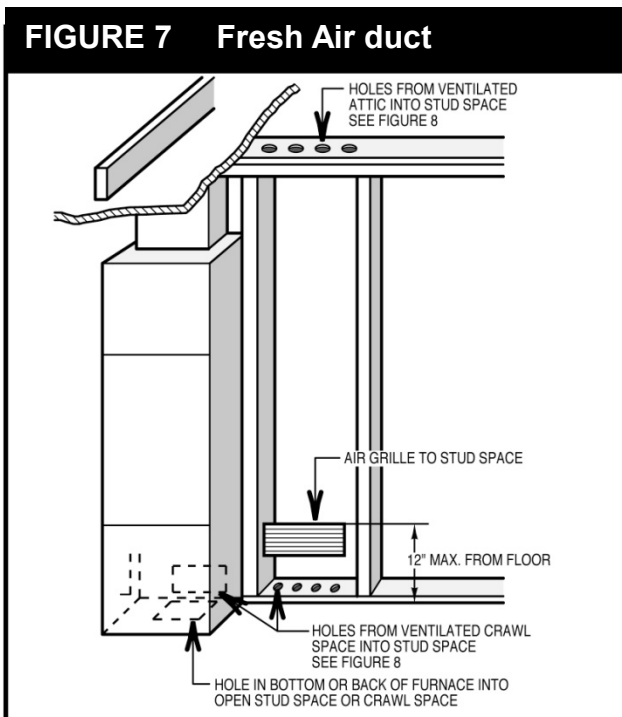

Fig. 7 shows a typical duct going into ventilated crawl space or attic.

1. Duct must terminate at a point not more than 1 foot above the floor.
2. Duct size must be at least 1 inch of free area for each 4000 Btu/hr. of input of all appliances in area.

## EXAMPLE 2.

### FURNACE LOCATED IN CONFINED SPACE.

If furnace is installed in a confined space, it must be provided with free air for proper combustion and ventilation of flue gases by one of the following methods.

#### A. All Air From Inside Building:

If the confined space adjoins an unconfined, provide two permanent openings, one within 12 inches of the top and one

within 12 inches of the bottom of the room connecting directly to unconfined space. Each opening must have a free area of at least 100 square inches or 1 square inch per 1000 Btu/hr. combined input of appliances in one room if combined input exceeds 100,000 Btu/hr.

**WARNING:** Danger of property damage, bodily injury or loss of life. The adjoining unconfined space must have adequate air infiltration as defined in example 1.

**FOR EXAMPLE:** Your furnace is rated at 50,000 Btu/hr. The water heater is rated at 30,000 Btu/hr. The total is 80,000 Btu/hr. You need two grilles, each with 100 square inches of free opening. Metal grilles have about 60% free area, so you need two metal grilles each with 160 square inches of louvered area.

**FIGURE 8 Minimum Area in Square Feet**

4000 Btu/hr. Per Square Inch Opening		Max Btu/hr. Input	*Unconfined Space Min. Area In Sq. Ft. 8' Ceiling Height
Round Duct	Rectangular Duct		
4" DIA.	3"X3" SQ.	30,000	188
4" DIA.	3"X3" SQ.	35,000	219
4" DIA.	3"X4" SQ.	40,000	250
4" DIA.	3"X4" SQ.	45,000	281
4" DIA.	3"X5" SQ.	50,000	312
4 1/2" DIA.	3"X5" SQ.	60,000	375

\* Can be two or more rooms joined by ventilation grilles.

Refer to figure as shown on Page 11, Fig. 9, which shows grille installation. Using the previous example, the two connecting rooms plus the closet must equal at least 500 sq. feet to handle the combined input 50,000 plus 30,000.

#### B. All Air From Outdoors:

If confined space doesn't adjoin an unconfined space then air must be provided from outdoors or spaces open to outdoors such as attic or crawl space.

Provide two permanent openings, one within 12 inches of top, one within 12 inches of bottom of room connecting directly, or by using ducts, with the outdoors or areas open to outdoors.

If opening connects directly to, or within vertical ducts, the free area of each opening must be at least 1 square inch per 4000 Btu/hr. combined input of appliances in area.

If horizontal ducts are used, the free area of each opening must be at least 1 square inch per 2000 Btu/hr. combined input of appliances in area.

# Installing Your Heater

**FIGURE 9 Grilles Connecting Rooms to Make Unconfined Space**

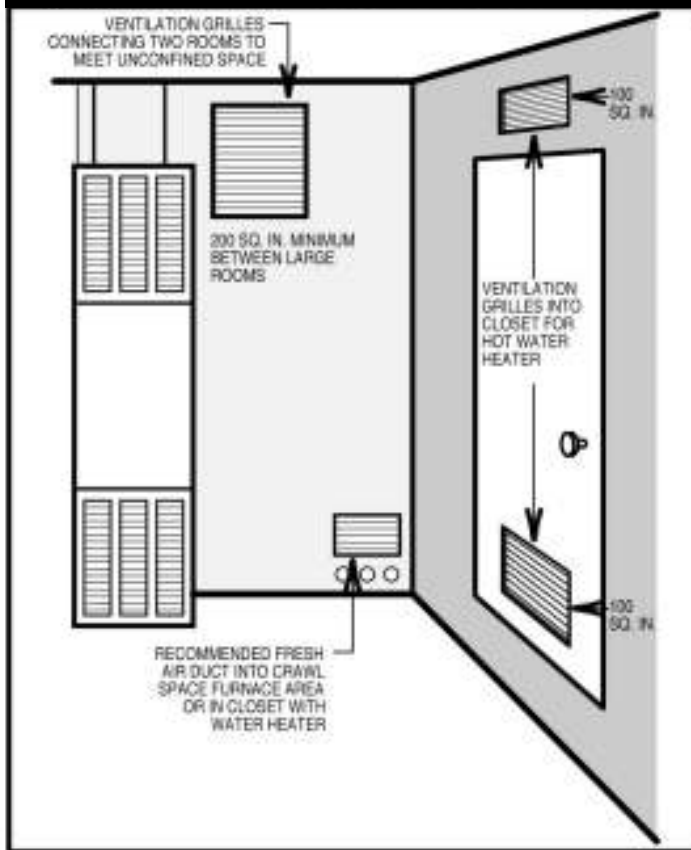

FOR EXAMPLE: Your furnace is rated at 50000 Btu/hr. The water heater is rated at 30,000 Btu/hr. The total is 80,000 Btu/hr. You need two grilles, each with 20-square inches of free opening, unless connected by horizontal ducts which would require each grille or opening to have a free area of 40 square inches.

**FIGURE 10 Air from Outdoors or Crawl Space**

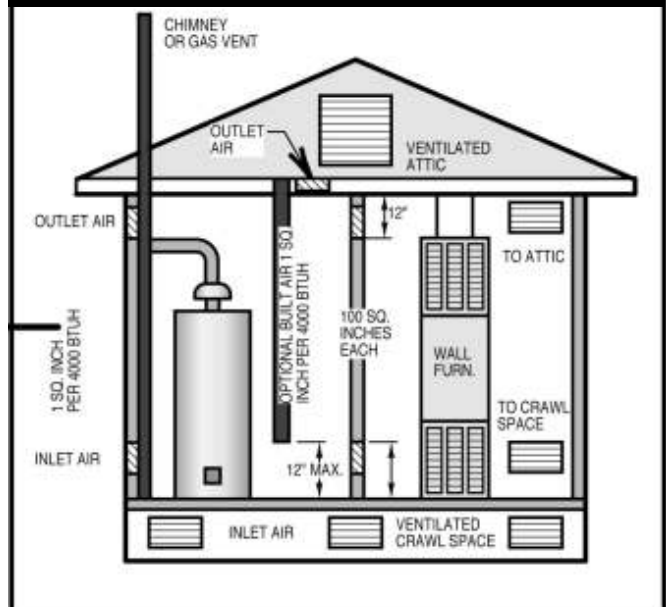

Openings for inlet or outlet air should not be made into attic area if attic is equipped with a thermostat controlled power vent.

**FIGURE 11 Free Area**

Furnace Btu/hr./Input	Sq. Inch of Opening	Req'd Number of Holes Sill or Header Plates		
		1 1/2"	2"	3"
30,000	7.5	7	4	2
35,000	8.75	8	5	2
40,000	10.0	9	5	3
45,000	11.25	10	6	3
50,000	12.5	11	6	3
60,000	15.0	13	8	4

Shown in square inches – each opening (furnace only)  
Based on one square inch per 4000 Btu/hr.

## Thermostat Installation (Sold Separately)

Williams' heaters are operated by a millivolt type thermostat. Current to the thermostat is supplied by the pilot generator. Do not connect to electricity. Anticipator settings are not required.

1. If an old thermostat is being replaced and is in a satisfactory location and the wiring appears to be in good condition, use existing wiring. If in doubt, use new wire.
2. If a new location is chosen or if this is a new installation, thermostat cable must first be run to the location selected. All wiring must agree with local codes and ordinances. These instructions cover bringing the wire down from the attic but it can be run from a basement or crawl space using similar methods.
3. Before drilling a hole in the wall at the selected location, drive a small finishing nail through the ceiling in the corner of the wall and ceiling above the thermostat location. Pull the nail out

and push a small stiff wire through the hole so it can be found in the attic. Drill a 1/2-inch hole through the ceiling wall plate.

4. Probe for obstructions in the partition. Then drill a 1/2-inch hole through the wall at the selected location for thermostat.
5. From the attic, feed the thermostat cable or a stiff wire through the wall until even with the thermostat location.
6. Snag the thermostat cable through the hole and pull the cable through the hole in the wall so that 6 inches of the cable protrudes.
7. Route the cable to the wall heater.
8. Never use nails or staples across the thermostat wires.

# Installing Your Heater

**CAUTION:** Label all wires prior to disconnection when servicing controls. Wiring errors can cause improper and dangerous operation. Verify proper operation after servicing.

Refer to installation instructions packed in the thermostat carton if you have any doubt about the above procedures. Use Williams thermostat P322016 or any millivolt thermostat.

## Wall-Mounted Thermostat Installation

1. To remove the thermostat cover, squeeze both sides and lift.
2. Connect the thermostat wires to the terminal screws on the thermostat base. Make sure the wiring does not interfere with thermostat operation.
3. Push any excess wire back through the hole in the wall and plug the hole with insulation to prevent drafts from affecting thermostat operation.
4. Being sure to level the thermostat for best appearance, fasten the thermostat base to the wall through the mounting holes with screws provided.
5. Replace the thermostat cover.
6. Do not run wire in any location where it might be damaged. Avoid splicing thermostat wires unless the spliced wires are properly cleaned, soldered and taped.
7. Use #18 gauge wire as supplied for a maximum length of 20 feet. If longer length is needed, use #16 gauge wire for a maximum length of 25 feet.
8. Connect the thermostat wires to the control valve as shown in Figure 12.

## Cabinet-Mounted Thermostat Installation

1. Locate the knockout on the right side of the heater to mount the thermostat. Remove the knockout by tapping lightly with a screwdriver. It will also be necessary to cut the inside panel insulation about a 1/2-inch in diameter for clearance to the knockout.
2. Cut the thermostat wire to the desired length.
3. Connect the thermostat wires to the terminal screws on the back of the thermostat base.
4. Feed the thermostat wires through the knockout and route through the metal clip to the gas valve. Models, 2001621A and 2001622A do not have a metal clip.
5. Mount the thermostat to the side of the cabinet with screws provided.

6. Replace the thermostat cover.
7. Connect the thermostat wires to the control valve as shown in Figure 12.

**IMPORTANT:** KEEP THE THERMOSTAT WIRE AWAY FROM THE COMBUSTION CHAMBER.

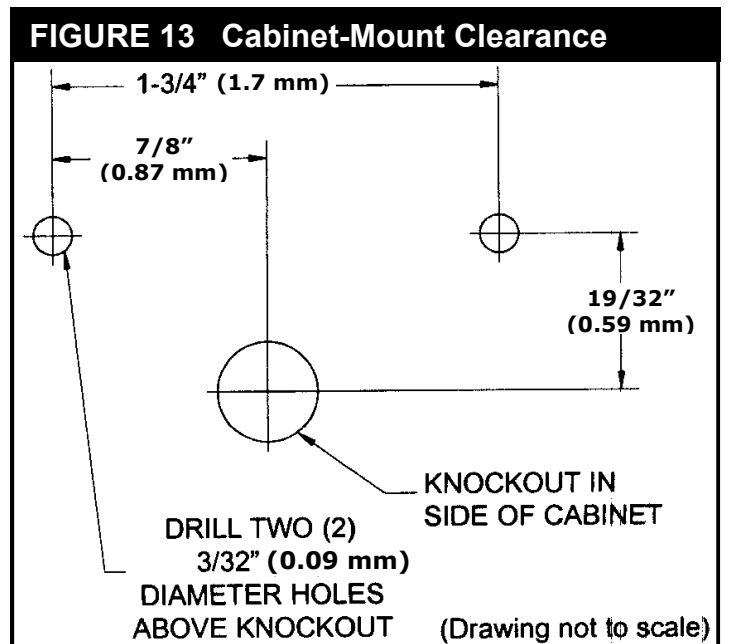
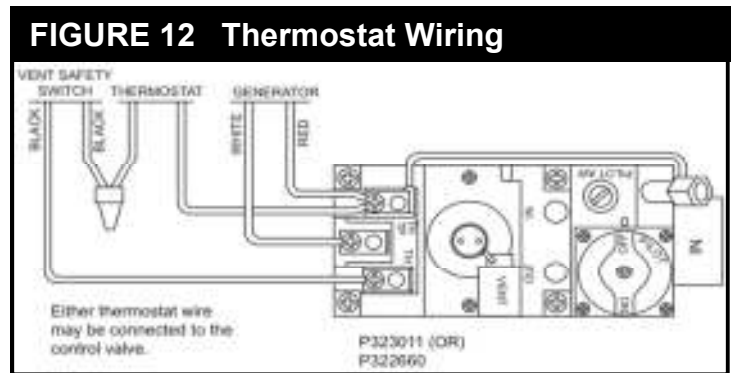

# Installing Your Heater

## Vent Installation

This heater must be properly connected to a venting system. This heater is equipped with a vent safety shutoff system to protect against improper venting of combustion products. Tampering with or removal of this control will void the limited warranty and can result in carbon monoxide (CO) poisoning and possible death.

**WARNING:** Operation of this heater, when not connected to a properly installed and maintained venting system or tampering with the vent safety shutoff system, can result in carbon monoxide (CO) poisoning and possible death.

This appliance needs fresh air for safe operation and must be installed so there are provisions for adequate combustion and ventilation air. This room heater is equipped with a vent safety switch. The vent safety switch will cause gas flow to the main burner to shutoff due to improper venting or a blocked flue. If the vent safety switch continues to shut off the gas flow, a qualified service person must be contacted to inspect for improper venting, blockage in the vent pipe or the vent safety switch for being defective.

**WARNING:** Do not bypass the vent safety shutoff switch. To do so could expose the consumer to property damage, personal injury or possible death.

**WARNING:** Danger of illness, bodily injury or death. This heater and any other fuel burning appliance must be provided with enough fresh air for proper combustion and ventilation of flue gases. Most homes will require that outside air be supplied into the heater area.

1. An effective flue is necessary to carry off water vapor, carbon monoxide (CO), carbon dioxide (CO<sub>2</sub>), and other products of combustion. For proper venting, follow the following basic rules for gravity venting, which are:
  - a. Keep the flue gases hot.
  - b. Follow the vent manufacturer's installation instructions.
  - c. Select the proper vent size.
  - d. Provide constant fresh air replacement.
2. For new installation, it is recommended that a Type "B" vent in accordance with its' listing be used. A Type "B" vent is one made of non-combustible, corrosion resistant material of sufficient thickness, cross sectional area and heat insulating quality to avoid excess temperatures on adjacent combustible material and certified by a nationally recognized testing agency. Existing brick flues should be lined to provide an effective vent. Brick chimneys, even in good repair, may be too large and will not provide sufficient draft to effectively vent a heater.

3. Use vent pipe of the same size as the outlet on back of heater. In no case should a different size vent be used. Single wall vent pipe may be attached directly to the draft hood of the room heater when a clearance of 3 inches (76.2 mm) is maintained between the single wall vent pipe and the combustible wall of the room in which the room heater is located. Use double wall vent pipe for clearances less than 3 inches (76.2 mm) to combustibles.
4. Avoid a horizontal run to the vent pipe whenever possible. When a horizontal run is necessary, the pipe must pitch upward at least 1/4 inch per foot. It must be supported securely and joints fastened by sheet metal screws or rivets. Under no circumstances should the vent run downhill.
5. Never put a damper or barometric draft control in a gas vent pipe.
6. Never end a vent in an open attic or run a vent through a wall to the outside without extending it upward above the roof.
7. Always terminate the vent with an approved vent cap.
8. ALWAYS SECURE THE VENT PIPE TO THE OUTLET ON THE BACK OF THE HEATER WITH A SHEET METAL SCREW.
9. The flue pipe should extend through the wall of a chimney to be flush with the inner wall.
10. The flue pipe must be adequately supported by metal strips.
11. For the flue pipe running through walls and roofs, use B type (1 inch (25mm) clearance to combustibles) vent pipe.
12. Vents should extend at least 2 feet (.6m) above the roof and above any object or nearby building within 10 feet (3m).
13. Open tees should not be used in the flue pipe.
14. The heater must not be connected to a chimney flue that is servicing a separate solid-fuel burning appliance.
15. Run flue pipe as direct as possible with not more than two elbows. Use 45 degree elbows if possible.
16. The use of more than one appliance per vent system may cause the vent safety shutoff device to shut off the heater due to the cooling of vent temperatures through the draft diverter of the second appliance.
17. The vent safety shutoff may shut down the heater if a too large or an unlined, masonry chimney is used. The vent may not warm quickly enough to get adequate vent action in a chimney before the shutoff device will shut down the heater. If this is the case, it is recommended lining the chimney with proper size type "B" vent pipe or type "B" chimney liner.
18. Single-wall metal pipe should not be used outdoors in cold climates or venting gas equipment. If the vent is installed directly outside, the cold pipe may delay the venting and cause the heater to shut-off by the vent safety switch. To prevent this problem, as well as condensation of flue products, an insulated enclosure is recommended. Use type B, vent pipe and maintain at least a one inch clearance to combustibles. Use a metal thimble to protect vent pipe as it passes through combustibles.

**IMPORTANT:** Inspect venting system prior to each heating season.

# Installing Your Heater

## Typical Methods of Safely Venting Your Heater

1. Any horizontal run of vent pipe must slope upward a minimum of 1/4" per foot. Secure all joints of the vent with sheet metal screws.
2. Where the vent passes through the ceiling or wall, a thimble is required to keep the ceiling from catching fire. Use only a thimble designed for use with Type "B" gas vent, certified by a nationally recognized testing agency.
3. The vertical (straight up and down) part of the vent must end 2 feet above any part of the roof within 10 feet of the vent. This is to make sure the "draw" of the vent is not obstructed in any way.
4. A vent cap, approved by a nationally recognized testing agency, must be installed on top of the vent to keep out rain and snow and to prevent obstructions of the vent. The vent cap will also prevent excessive downdraft that can cause carbon monoxide to enter into the home. Do not use a homemade vent cap. They are dangerous and can restrict the draft of the vent.
5. Safe clearances are shown below. To prevent a fire, make sure the heater is installed no closer than the distances shown in the figures that apply to your type of venting.
6. If you are venting into a masonry chimney, it must be lined, in good repair and must not serve a wood or coal burning appliance. The flue must be at least as large in diameter as the vent connector. The top of the chimney must be two (2) feet higher above any part of the roof within ten (10) feet horizontally of the chimney and must be three (3) feet higher than the point where it passes through the roof line. If installed in front of a fireplace, the pipe must pass through a sheet metal cover on the fireplace that fits tightly.

**FIGURE 14 Venting Into A Masonry Chimney**

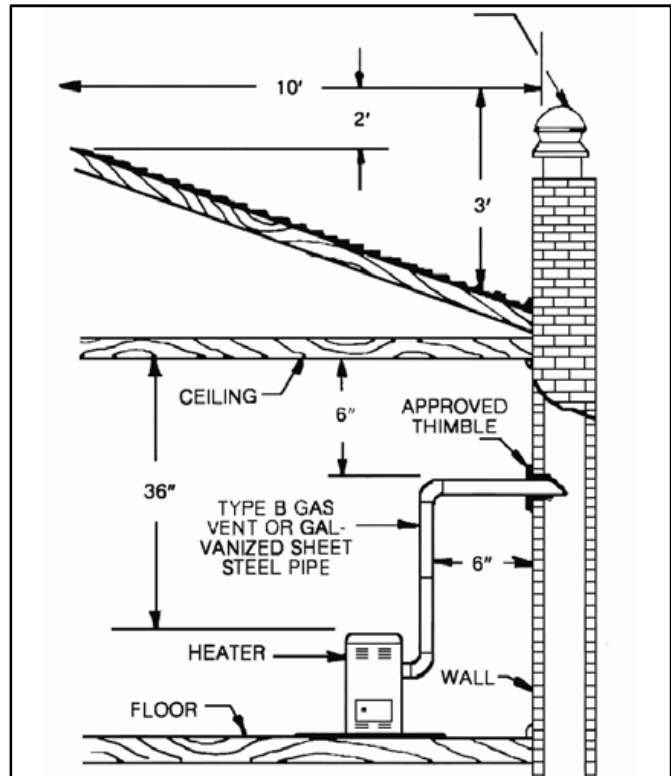

# Installing Your Heater

**FIGURE 15** Straight Up Venting With Type "B" Gas Vent

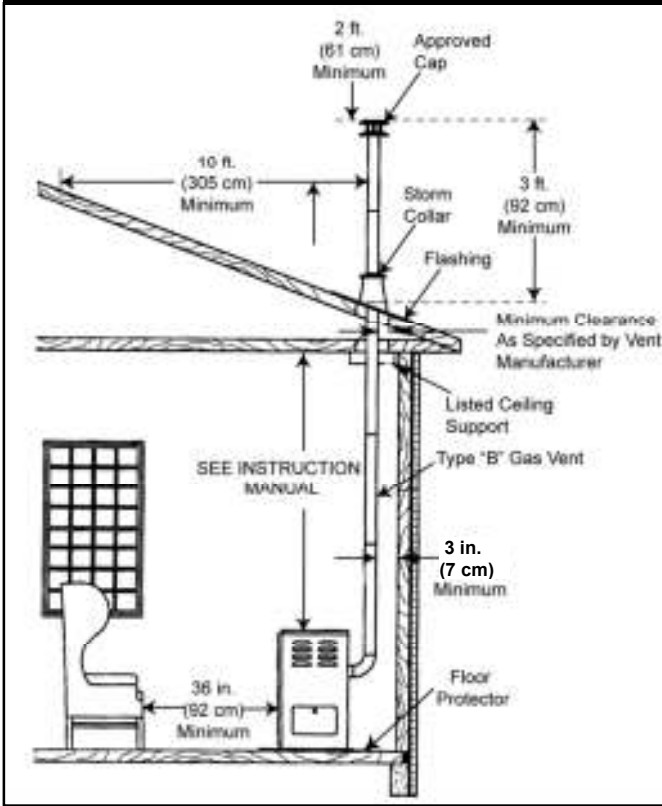

**FIGURE 16** Venting Into An Outside Type "B" Gas Vent

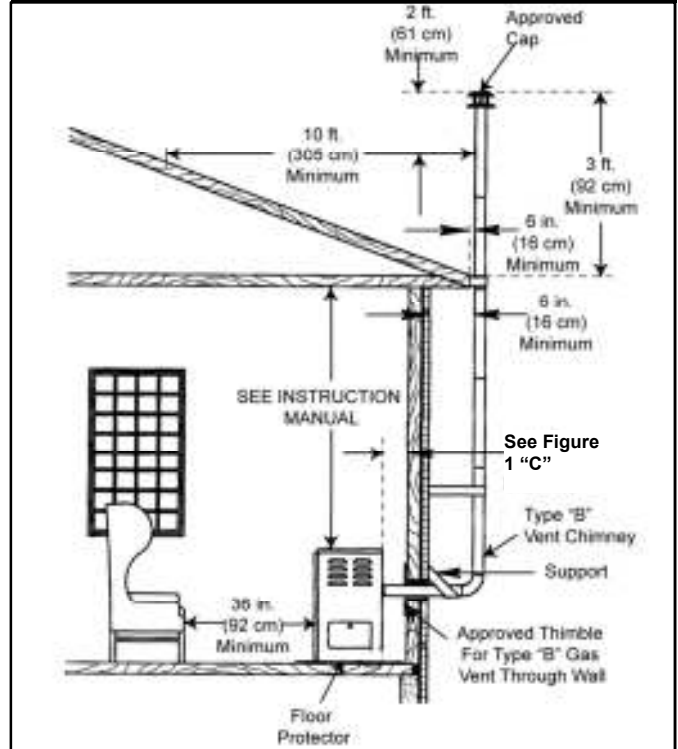

# Operating Your Heater

## Start-Up Procedure

Start the heater using the procedures in the section "Operating Your Heater".

**WARNING:** Danger of bodily injury or death. L.P. Gas is heavier than air and it will settle in any low area, including open depressions and it will remain there unless the area is ventilated.  
Never attempt to start-up the unit before thoroughly ventilating the area.

Check the heater operation as outlined in the following instructions. If any sparking, odors or unusual noises are encountered, shut off the electric power immediately. Recheck for wiring errors or obstructions in or near the fan motor.

### CHECK GAS INPUT AND PRESSURES

For heaters located at elevations between sea level and 2,000 feet, the measured input must not be greater than the input shown on the rating plate of the heater. For elevations above 2,000 feet, the measured input must not exceed the input on the rating plate reduced by 4 percent for each 1,000 feet that the heater is above sea level.

Gas supply pressure and manifold pressure with the burners operating is specified on the rating plate.

Type of Gas	Manifold Pressure, In. W.C.
Natural	4.0"
L.P.	10.0"

Rated input will be obtained on a heating value of 2,500 Btu/hr. for propane at 10-inches manifold pressure with factory-sized orifices. If L.P. Gas having a different heating value is supplied, orifices must be changed by a qualified service technician before the heater is operated.

### CHECK THERMOSTAT

Check the thermostat operation. When set above room temperature shown on the thermostat, the main burner should light. Make certain the thermostat turns off the heater when the room temperature reaches the selected setting and starts the heater when the room temperature falls a few degrees.

### CHECK THE MANIFOLD GAS PRESSURE

A tapped opening is provided in the gas valve to facilitate measuring the manifold gas pressure. A "U Tube" manometer having a scale range from 0 to 12-inches of water should be used for this measurement. The manifold pressure must be measured with the burner and pilot operating. Any major changes in flow must be made by changing the size of the burner orifice.

Check with your local gas supplier for proper orifice sizing.

### CHECK THE GAS INPUT (NATURAL GAS ONLY)

**WARNING:** Natural gas heating value (Btu per cubic foot) can vary significantly. Therefore, it is the installer's responsibility to see that Btu/hr. input to the heater is adjusted properly. Failure to do so could cause combustion chamber failure, asphyxiation, fire or explosion resulting in damage, bodily injury or death. Refer to the National Fuel Gas Code (NFPA 54) to be sure the heater is burning fuel at the proper rate.

Under firing could cause inadequate heat, excessive condensation or ignition problems. Over firing could cause sooting, flame impingement or overheating of the combustion chamber.

Before starting natural gas input check, obtain heating value of the gas (Btu per cubic foot) at standard conditions from your local supplier.

To measure the input, using the gas meter, proceed as follows:

1. Turn off gas supply to all other appliances except the heater.
2. With the heater operating, time the smallest dial on the meter for one complete revolution. If this is a 2-cubic-foot dial, divide the seconds by 2. If this is a 1-cubic-foot dial, use the time in seconds as is (3,600 = Sec/hr.). This gives the seconds per cubic foot of gas being delivered to the heater.
3. Assuming natural gas with a heating value of 1,000 Btu per cubic foot and 34-seconds per cubic foot used as determined by step (2), then:  
$$\text{Input} = 1,000 \times 3,600 / 34 = 106,000 \text{ Btu/hr.}$$
This measured input must not be greater than the input indicated on the nameplate of the heater.
4. Relight all other appliances turned off in Step 1 above. Be sure all pilots are operating.

### CHECK PILOT BURNER

The pilot flame must envelop 1/2- to 5/8-inches of the generator. Pilot flame is preset at the factory, so ordinarily does not require field adjustment. (Figure 17). On new installations, the gas lines will be filled with air and may take several minutes to establish a pilot flame.

**FIGURE 17 Pilot Burner**

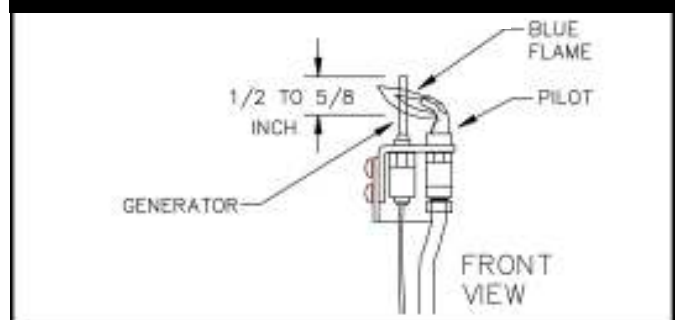

# Operating Your Heater

**FIGURE 18 Burner Flame Characteristics**

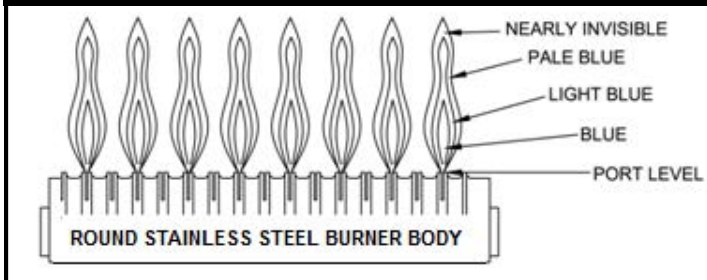

## Burner Flame Characteristics

Start the heater and let it operate for at least 10 minutes. Open the access door to view the burner flame. Limit your movements near the heater a few more minutes before making your final observation. The flame may look yellow due to dust particles in the room air. The flame should change to a nice blue color with firm inner and secondary cones. An occasional flash of orange might be seen as dust particles burn in the flame. This is normal. No burner adjustment is provided, or is necessary. (Figure 18).

### Normal Appearance

#### Natural Gas:

1. Inner cone- blue color - 3/8 to 5/8-inch above ports.
2. Secondary inner cone - light blue - 1 to 2-inches above ports.
3. Total flame - from blue to nearly invisible - approximately 6-inches above ports.

#### L.P Gas:

1. Inner cone - blue color - 1/2 to 3/4-inch above ports.
2. Secondary inner cone - light blue - 1 to 2-inches above ports.
3. Total flame - from blue to nearly invisible - approximately 6-inches above ports.

## Gas Conversion Kits

Gas Conversion Kits	
Natural Gas to L.P. Gas	
Model	Description
8945	200 Series
8946	350 Series
8947	500 Series
8948	650 Series

Gas Conversion kits	
L.P. Gas to Natural Gas	
Model	Description
8949	200 Series
8950	350 Series
8951	500 Series
8952	650 Series

### Abnormal Appearance

#### Lazy Flame:

Long soft yellow cones moving around in the combustion chamber lifting from ports (insufficient air).

#### Extremely Fast Flame:

Will not hold to ports - entire cone sections blow off from noisy ports (too much pressure).

**WARNING:** If the flame appears abnormal, contact the gas company or a qualified service technician immediately.

**WARNING:** Natural gas heating value (Btu per cubic foot) can vary significantly; therefore, it is the installer's responsibility to see that the Btu input to the heater is adjusted properly. Failure to do so could cause combustion chamber failure, asphyxiation, fire or explosion, resulting in property damage, bodily injury or death. Refer to the National Fuel Code (NFPA-54) to be sure the heater is burning fuel at the proper rate.

# Operating Your Heater

## FOR YOUR SAFETY, READ BEFORE LIGHTING

**WARNING:** If you do not follow these instructions exactly, a fire or explosion may result causing property damage, personal injury or loss of life.

- A. This appliance has a pilot which must be lighted by hand. When lighting the pilot, follow these Instructions exactly.
- B. BEFORE LIGHTING smell around the appliance area for gas. Be sure to smell next to the floor because some gas is heavier than air and will settle on the floor.

### WHAT TO DO IF YOU SMELL GAS

- Do not try to light any appliance or strike a match.
- Do not touch any electric switch; do not use any phone or cell phone in your building.
- Immediately call your gas supplier from a neighbor's phone. Follow the gas supplier's instructions.

- If you cannot reach your gas supplier, call the fire department.
- C. Use only your hand to push in or turn the gas control knob. Never use tools. If the knob will not push in or turn by hand, don't try to repair it, call a qualified service technician. Force or attempted repair may result in a fire or explosion.
  - D. Do not use this appliance if any part has been under water. Immediately call a qualified service technician to inspect the appliance and to replace any part of the control system and any gas control which has been under water.

NOTE: FOR ADDITIONAL INFORMATION REFER TO THE INSTALLATION AND OPERATION INSTRUCTION MANUAL SUPPLIED WITH THIS APPLIANCE OR CONTACT THE MANUFACTURER IDENTIFYING THE PRODUCT BY ITS MODEL NUMBER LOCATED ON THE RATING PLATE, FOUND NEAR THE GAS VALVE.

## OPERATING INSTRUCTIONS

1. STOP! Read the safety information above.
2. Set the thermostat to the lowest setting.
3. If applicable, turn off all electric power to the appliance.
4. Remove the control access panel.
5. Turn the gas control knob clockwise ↻ to "OFF".

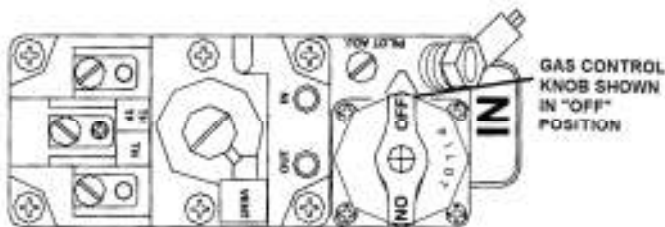

**NOTE:** Knob cannot be turned from "PILOT" to "OFF" unless knob is pushed in slightly. Do not use force.

6. Wait five (5) minutes to clear out any gas, then smell for gas, including near the floor. **If you then smell gas, stop!** Follow "B" in the safety information above. If you don't smell gas, go to the next step.
7. Loosen wing nut and open the pilot observation door (if equipped).
8. To find the pilot, follow the metal tube from the gas control valve. The pilot is mounted on the side of the burner.

9. Turn knob on the gas control counterclockwise ↺ to "PILOT."

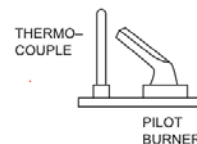

10. Push in the control knob all the way and hold in. Immediately light the pilot. Continue to hold the control knob in for about one (1) minute after the pilot is lit. Release the knob and it will pop back up. The pilot should remain lit. If it goes out, repeat Steps 5 through 10.
  - If the button does not pop up when released, stop and immediately call your service technician or gas supplier.
  - If the pilot will not stay lit after several tries, turn the gas control knob to "OFF" and call your service technician or gas supplier.
11. Close the pilot observation door and tighten the wing nut (if equipped).
12. Turn the gas control knob counterclockwise ↺ to "ON".
13. Replace the control access panel.
14. Turn on all electric power to the appliance.
15. Set the thermostat to the desired setting.

## TO TURN OFF GAS TO APPLIANCE

1. Set the thermostat to the lowest setting.
2. Turn off all electric power to the appliance if service is to be performed.
3. Remove the control access panel.
4. Push in the gas control knob slightly and turn it clockwise to "OFF". Do not Force.
5. Replace the control access panel.

**IMPORTANT:** KEEP BURNER AND CONTROL COMPARTMENT CLEAN.

**WARNING:** DUE TO HIGH SURFACE TEMPERATURES - KEEP CHILDREN, CLOTHING, FURNITURE OR ANY COMBUSTIBLE MATERIAL AWAY FROM THE HEATER.

# Caring for Your Heater

## How To Care For Your Heater

**WARNING:** Danger of bodily injury or death. Turn off electric power supply at the disconnect switch, fuse box or service panel before removing any doors or access or service panels from the unit.

### ANNUAL UPKEEP NEEDED

It is recommended that a qualified service technician perform these checks at the beginning of each heating season.

### CABINET FINISH

Clean the cabinet with a damp rag. Never use abrasive cleaners. Cabinets are finished in heat resistant powder coated finish - DO NOT refinish with wall paint.

### REMOVABLE CABINET TOP (350, 500, & 650 MODEL SERIES)

For ease of cleaning, access or replacement of internal parts, the top of this heater can be removed by following these steps:

1. Remove the three (3) brackets on the rear of the heater securing the cabinet top to the back plate.
2. Pull the cabinet top forward and lift up. Reinstall the cabinet top by reversing the procedures noted above. (Figure 19).

**Note:** Take special care to engage the six (6) clips located on the bottom of the cabinet top into the top flange of the heater sides.

**FIGURE 19 Removable Cabinet Top**

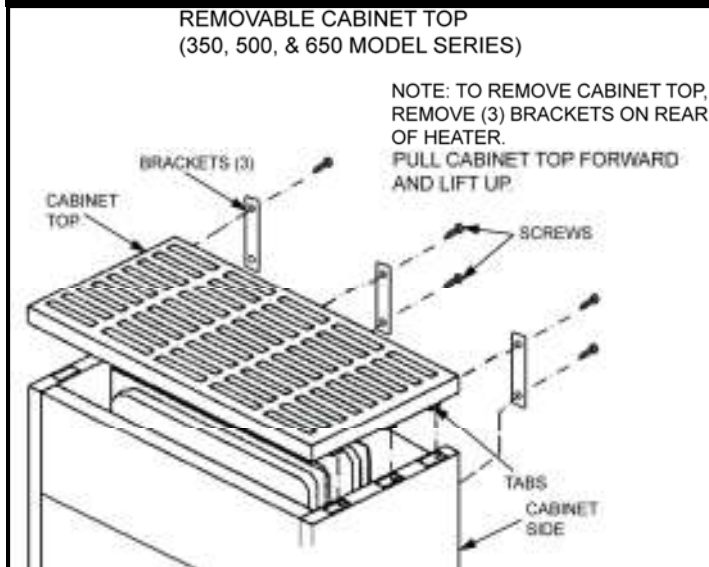

### HEATER AREA

Keep the area near the heater clear and free from combustible materials, gasoline and other flammable liquids and vapors.

### COMBUSTION AND VENTILATION AIR

The combustion and ventilation air supply must not be blocked.

Do not put anything in or on the heater cabinet.

For better circulation and more effective heating, do not place obstructions, furniture or other items closer than four feet to the front of the cabinet or two feet from each side of the cabinet.

### CLEANING BLOWER (IF EQUIPPED)

Shut off electricity. Clean any lint or dirt from fan blades, fan motor and exposed air passages. Annually put two drops of SAE 20 oil in each of the two cups or oil tubes.

### PILOT BURNER

Light the pilot using the instructions in OPERATING YOUR HEATER. Leave the thermostat at the lowest setting.

The pilot flame should surround 1/2 to 5/8 inches of the generator tip. If the flame needs adjusting, do it as follows:

### ADJUST PILOT BURNER

1. Insert a small screwdriver, adjust the flame as needed. Turn the screw counterclockwise to increase the flame, clockwise to decrease.
2. Turn the thermostat to the highest setting. The main burners should light quickly and smoothly. Turn the thermostat to its lowest setting. Main burners should go out. The pilot should remain lit.
3. Refer to Figure 20.

### VENTING SYSTEM

Make sure that no parts of the vent air system are blocked, rusted or damaged. Clean or replace before using the heater.

### BURNER CLEANING

Check the burner. If cleaning is required, contact a qualified service technician to clean and service burner.

**FIGURE 20 Pilot Adjustment Screw**

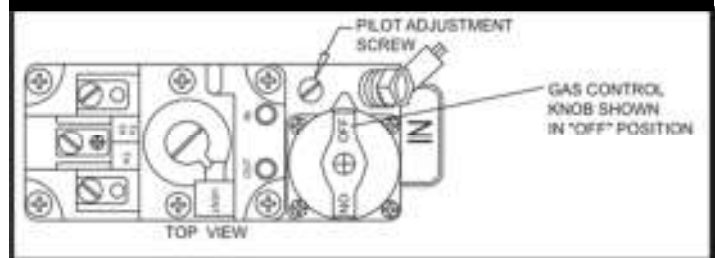

# Caring for Your Heater

## CLEANING BURNER COMPARTMENT

Because cold air is attracted to the flame during heater operation, a build up of lint from carpeting, bedding, dust, etc. in the burner area will occur. It is necessary to clean this area regularly. Use a vacuum cleaner with a narrow attachment to reach small areas. Be careful in and around the pilot. A change in its adjustment could be made if moved during cleaning.

**DANGER:** A build up of any dust, lint or foreign material in the primary air opening of the burner can interfere with the proper air gas mixture and can result in a yellow flame which can produce carbon monoxide and soot. This condition if allowed to develop, can lead to bodily injury including death. It is imperative that the burner be kept clean.

## TO REMOVE LOGS FROM COMBUSTION CHAMBER

Always remove the logs from the combustion chamber when cleaning the burner or combustion chamber.

1. As parts are removed, place them in a safe place until ready for reassembly.
2. Remove the chrome hearth assembly. Compression clips hold hearth assembly in place. Grasp the assembly frame and pull forward.
3. Remove the screws in the glass window frame.

**IMPORTANT:** The logs are made of special lightweight materials that can be easily damaged by rough handling.

4. Lift the front log up and out of the front log support brackets carefully. Take care when pulling it out through the window opening. Do not scrape it against the metal edges of the opening.
5. Remove the screws and plates holding the top right and the top left sides of the rear log set against the top rear support brackets.
6. Lift the rear log set up and out of the bottom support brackets. Tilt the top towards the back and slowly allow the bottom to pass through the opening first. Take care not to scrape it against the metal edges of the opening.
7. Reverse the above procedure to reassemble after cleaning.

**FIGURE 21 Log Mounting**

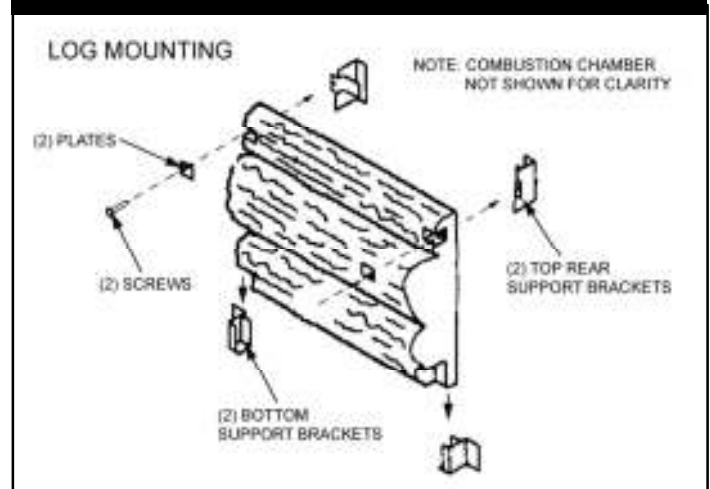

## GLASS CLEANING

Use mild soap and water only. Never clean when the glass is hot.

If the glass is broken it must be replaced with the manufacturer's authorized part only. Failure to do so could cause property damage, bodily injury or death.

**NOTE:** A properly adjusted burner with nearly all gases will produce a flame which has a clear blue cone having a bluish-red or bluish-violet outer mantle.

# Replacement Parts

FOR MODELS: 2001621A; 2011621A; 2031621A; 2051621A; 2001622A; 2011622A; 2031622A; 2051622A

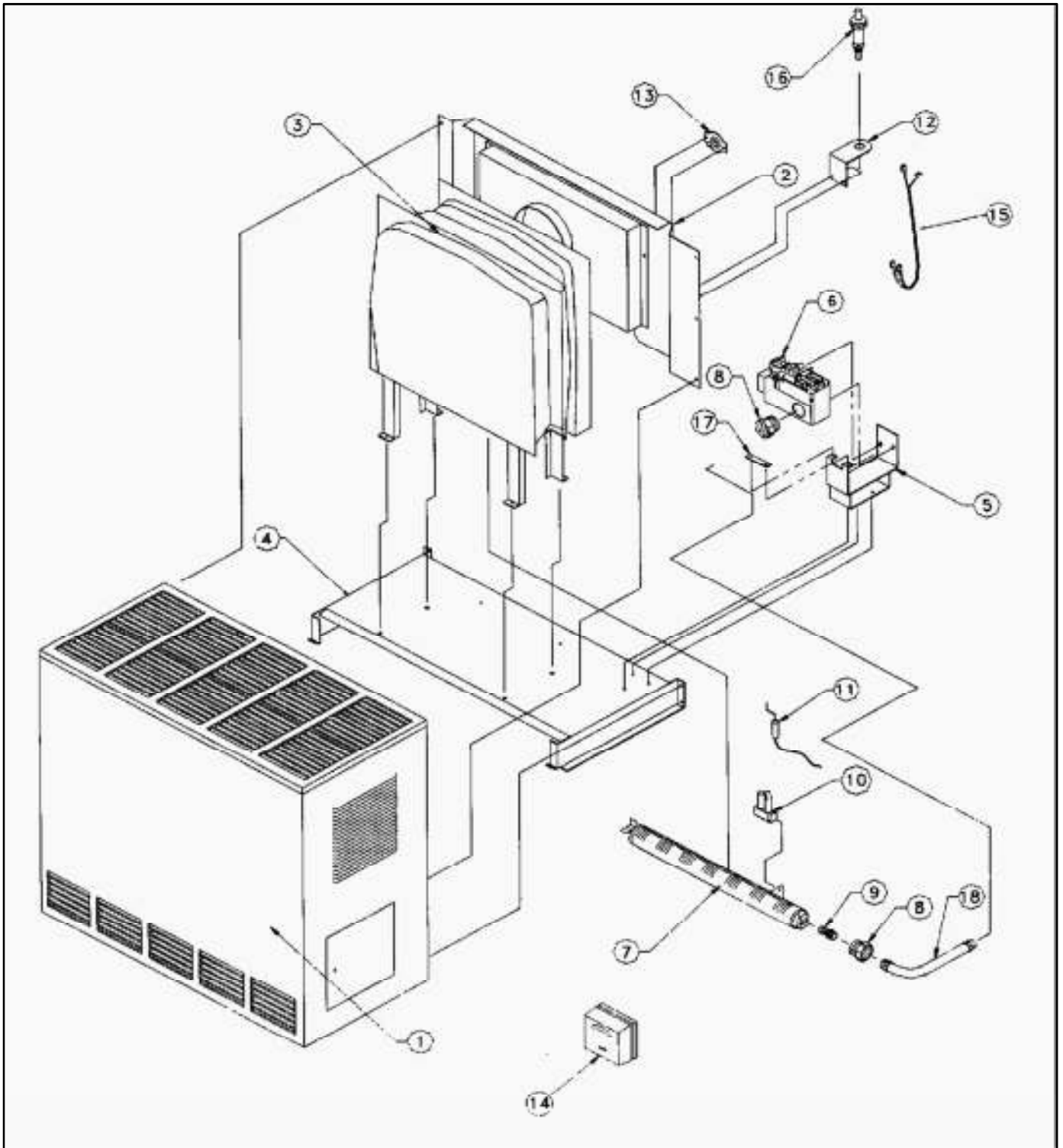

FOR PART LIST SEE PAGE 22.

# Replacements Parts

## REPLACEMENT PARTS LIST FOR MODELS 2001621A; 2011621A; 2031621A; 2051621A; 2001622A; 2011622A; 2031622A; 2051622A

Ref. Number	Description	PART NO. FOR MODEL	
		2001621A; 2011621A; 2031621A; 2051621A	2001622A; 2011622A; 2031622A; 2051622A
1	Wrapper Assembly	K000275	K000275
2	Draft Diverter Assembly	K000274	K000274
3	Combustion Chamber	8957	8957
4	Base Plate	K000265	K000265
5	Valve Bracket	K000850	K000850
6	Control Valve	P322660	P323011
7	Burner	K000851	K000851
8	Orifice Fitting	P500086	P500086
9	Burner Orifice	P501800	P501781
10	Pilot	P323073	P323074
11	Thermocouple	P043800	P043800
12	Igniter Bracket	7A189	7A189
13	Vent Safety Switch	P323663	P323663
14	Thermostat	P322016	P322016
15	Wire Assembly	P500409	P500409
16	Manual Spark Igniter	P285500	P285500
17	Manifold Plate	K000852	K000852
18	Manifold Assembly	P323681	P323681

For part illustration, see page 21.

Note: Screws and bolts are standard hardware items, available locally.

# Replacement Parts

## ENCLOSED FRONT

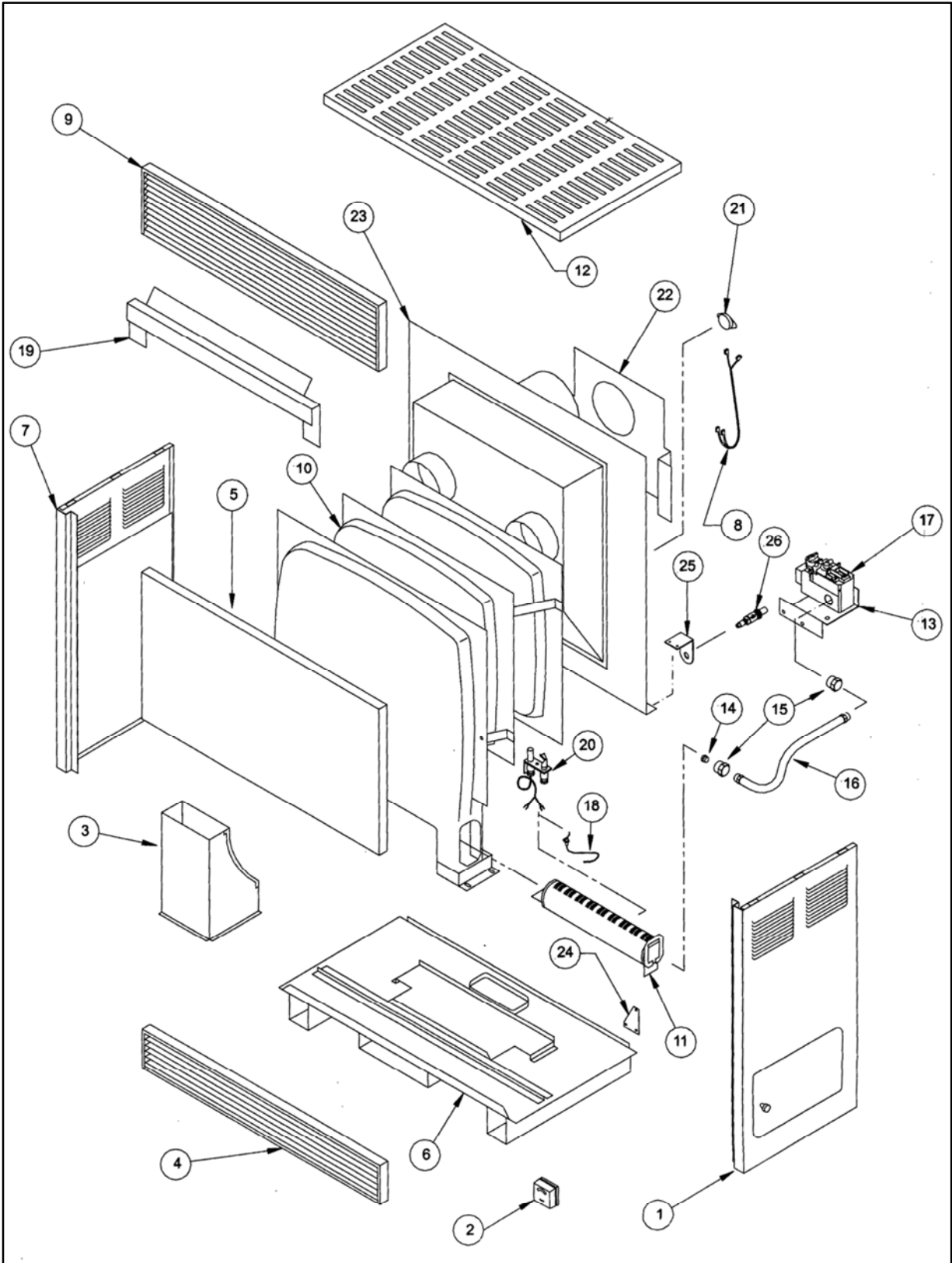

FOR PART LIST SEE PAGE 24.

# Replacements Parts

## REPLACEMENT PARTS LIST FOR ENCLOSED FRONT

Ref. Number	Description	PART NO. FOR MODEL					
		3501522A 3511522A 3531522A 3551522A 3501922A 3511922A 3531922A 3551922A	3501521A 3511521A 3531521A 3551521A 3501921A 3511921A 3531921A 3551921A	5001522A 5011522A 5031522A 5051522A 5001922A 5011922A 5031922A 5051922A	5001521A 5011521A 5031521A 5051521A 5001921A 5011921A 5031921A 5051921A	6501522A 6511522A 6531522A 6551522A 6501922A 6511922A 6531922A 6551922A	6501521A 6511521A 6531521A 6551521A 6501921A 6511921A 6531921A 6551921A
1	Panel Side Right	K000204	K000204	K000205	K000205	K000206	K000206
2	Thermostat	P322016	P322016	P322016	P322016	P322016	P322016
3	Inlet Duct	K7000-6022	K7000-6022	K7000-6022	K7000-6022	K7000-6022	K7000-6022
4	Bottom Louver Assembly	K000182-1	K000182-1	K000182-2	K000182-2	K000182-3	K000182-3
5	Center Panel	K000220	K000220	K000221	K000221	K000222	K000222
6	Cabinet Bottom	K5000-6003	K5000-6003	K5000-6004	K5000-6004	K5000-6019	K5000-6019
7	Panel Side Left	K000207	K000207	K000208	K000208	K000209	K000209
8	Wire Assembly	P500409	P500409	P500416	P500416	P500416	P500416
9	Top Louver Assembly	K000181	K000181	K000212-1	K000212-1	K000212-2	K000212-2
10	Combustion Chamber	8958	8958	8960	8960	8962	8962
11	Burner	P501620	P501620	P501621	P501621	P501622	P501622
12	Cabinet Top	K000223	K000223	K000224	K000224	K000225	K000225
13	Control Bracket	K000147	K000147	K000147	K000147	K000147	K000147
14	Orifice	P500336	P500351	P500330	P500345	P500327	P500432
15	Orifice Fitting	P500086	P500086	P500086	P500086	P500086	P500086
16	Manifold Assembly	P323678	P323678	P323679	P323679	P323680	P323680
17	Gas Control Valve	P323011	P322660	P323011	P322660	P323011	P322660
18	Thermocouple	P043801	P043801	P043801	P043801	P043801	P043801
19	Shield Cover	-	-	K7011-6030	K0711-6030	-	-
20	Pilot	P323074	P323073	P323074	P323073	P323074	P323073
21	Vent Safety Switch	P323663	P323663	P323664	P323664	P323664	P323664
22	Heat Shield (Rear)	K7003-6370	K7003-6370	K7003-6371	K7003-6371	K7003-6372	K7003-6372
23	Back Plate	K000309	K000309	K000310	K000310	K000526	K000526
24	Rear Corner Brace	K7003-6097	K7003-6097	K7003-6097	K7003-6097	K7003-6097	K7003-6097
25	Bracket	7A189	7A189	7A189	7A189	7A189	7A189
26	Manual Spark Igniter	P285500	P285500	P285500	P285500	P285500	P285500

For part illustration, see page 23.

Note: Screws and bolts are standard hardware items, available locally.

# Replacement Parts

FIREPLACE-LOOK WITH LOGS

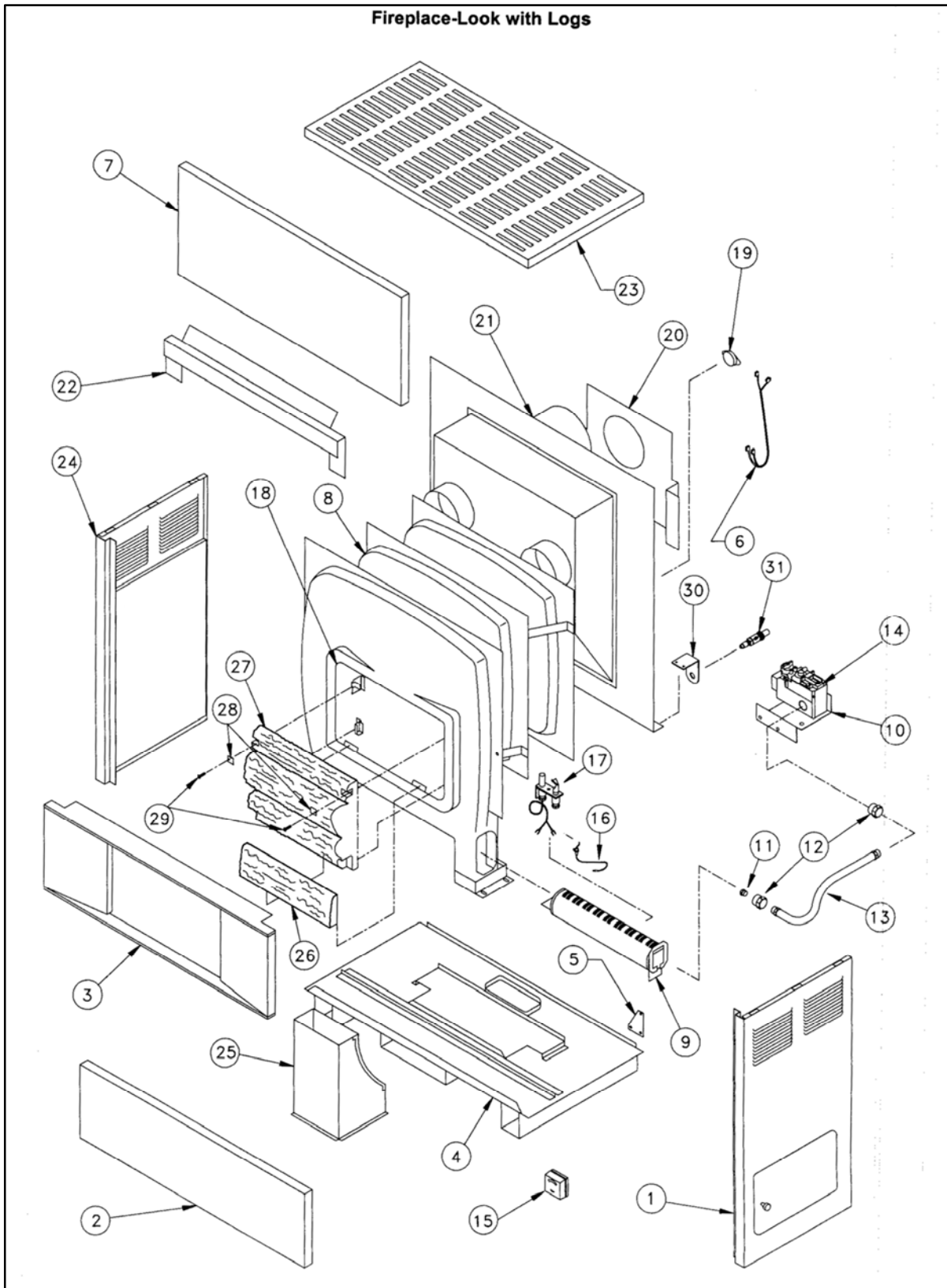

FOR PART LIST SEE PAGE 26.

# Replacements Parts

## REPLACEMENT PARTS LIST FOR FIREPLACE-LOOK WITH LOGS

Ref. Number	Description	PART NO. FOR MODEL					
		3502522A	3502521A	5002522A	5002521A	6502522A	6502521A
		3512522A	3512521A	5012522A	5012521A	6512522A	6512521A
		3532522A	3532521A	5032522A	5032521A	6532522A	6532521A
		3552522A	3552521A	5052522A	5052521A	6552522A	6552521A
		3502922A	3502921A	5002922A	5002921A	6502922A	6502921A
		3512922A	3512921A	5012922A	5011921A	6512922A	6512921A
		3532922A	3532921A	5032922A	5032921A	6532922A	6532921A
		3552922A	3552921A	5052922A	5052921A	6552922A	6552921A
1	Panel Side Right	K000204	K000204	K000205	K000205	K000206	K000206
2	Bottom Panel	K000229	K000229	K000230	K000230	K000231	K000231
3	Hearth	K000462	K000462	K000463	K000463	K000464	K000464
4	Cabinet Bottom	K5000-6003	K5000-6003	K5000-6004	K5000-6004	K5000-6019	K5000-6019
5	Rear Corner Brace	K7003-6097	K7003-6097	K7003-6097	K7003-6097	K7003-6097	K7003-6097
6	Wire Assembly	P500409	P500409	P500416	P500416	P500416	P500416
7	Top Panel	K000232	K000232	K000233	K000233	K000234	K000234
8	Combustion Chamber	8959	8959	8961	8961	8963	8963
9	Burner	P501620	P501620	P501621	P501621	P501622	P501622
10	Control Bracket	K000147	K000147	K000147	K000147	K000147	K000147
11	Burner Orifice	P500336	P500351	P500330	P500345	P500327	P500432
12	Orifice Fitting	P500086	P500086	P500086	P500086	P500086	P500086
13	Manifold Assembly	P323678	P323678	P323679	P323679	P323680	P323680
14	Gas Control Valve	P323011	P322660	P323011	P322660	P323011	P322660
15	Thermostat	P322016	P322016	P322016	P322016	P322016	P322016
16	Thermocouple	P043801	P043801	P043801	P043801	P043801	P043801
17	Pilot	P323074	P323073	P323074	P323073	P323074	P323073
18	Window Assembly	K000450	K000450	K000451	K000451	K000452	K000452
19	Vent Safety Switch	P323663	P323663	P500406	P500406	P323663	P323663
20	Heat Shield	K7003-6370	K7003-6370	K7003-6371	K7003-6371	K7003-6372	K7003-6372
21	Back Plate	K000309	K000309	K000527	K000527	K000311	K000311
22	Shield Cover	-	-	K7011-6030	K7011-6030	K7011-6031	K7011-6031
23	Cabinet Top	K000223	K000223	K000224	K000224	K000225	K000225
24	Panel Side Left	K000207	K000207	K000208	K000208	K000209	K000209
25	Inlet Duct	K7000-6022	K7000-6022	K7000-6022	K7000-6022	K7000-6022	K7000-6022
26	Front Log	P500678	P500678	P500679	P500679	P500680	P500680
27	Rear Log Set	P500674	P500674	P500675	P500675	P500676	P500676
29	Stainless Steel Screw (2	P103200	P103200	P103200	P103200	P103200	P103200
30	Bracket	7A189	7A189	7A189	7A189	7A189	7A189
31	Manual Spark Igniter	P285500	P285500	P285500	P285500	P285500	P285500

For part illustration, see page 25.

Note: Screws and bolts are standard hardware items, available locally.

# Blower Accessory 2102

## Mounting the Blower

**Note:** All electrical work must conform to your local codes and ordinances or in their absence, with National Electrical Code, ANSI/NFPA 70. If you are not familiar with wiring codes in general, have a competent electrician do this job. In CANADA: CANADIAN ELECTRICAL CODE C22.1.

**WARNING:** Danger of property damage, bodily injury or death. Turn off electrical power supply at disconnect switch, fuse box or service panel before removing or working on fan.

1. Place the motor and blower on the heater floor, securing with four (4) screws. Attach three (3) screws to the inlet duct and one (1) screw to the heater floor, using the existing screw holes. Align the opening in the base of the motor and blower with the opening in the heater floor. The opening on the side of the motor and blower should align with the opening on the heater inlet duct.
2. Attach the "HI" and "LO" speed switch to the upper left corner on the back of the heater and replace the corner bracket with the speed switch plate using the existing mounting holes. The correct position for the fan switch is shown below. The top of the fan switch should be level with the notch directly across the switch on the blower mounting plate. **Make sure speed switch wires are secured with clamp (provided in the kit) away from the combustion chamber before operating the heater.**

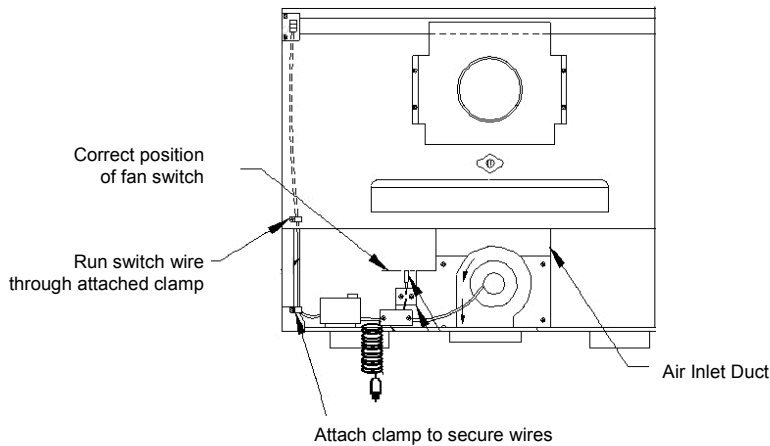

## Wiring

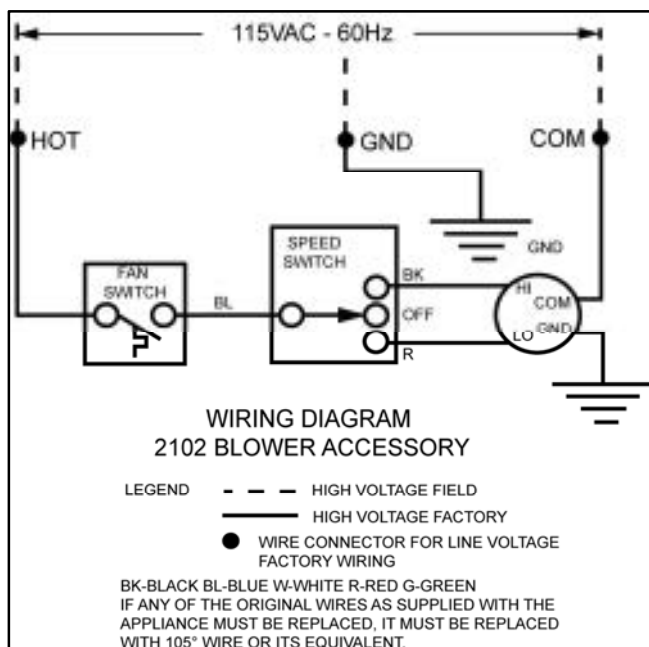

# Blower Accessory 2102

## Operation

This accessory is operated using the factory equipped, three-prong (grounding) plug and cord. When using the plug and cord, for your protection against shock hazard, it must be plugged directly into a properly grounded three-prong receptacle. **DO NOT CUT OR REMOVE THE PRONG.**

You must select "HI" or "LO" on the speed switch (item 8) for automatic blower operation. When the heater heats up, the fan switch is activated and the blower will operate. When the heater cools down, the blower will turn off. The blower will not operate if the speed switch is set in the "OFF" (center) position.

## Replacement Parts

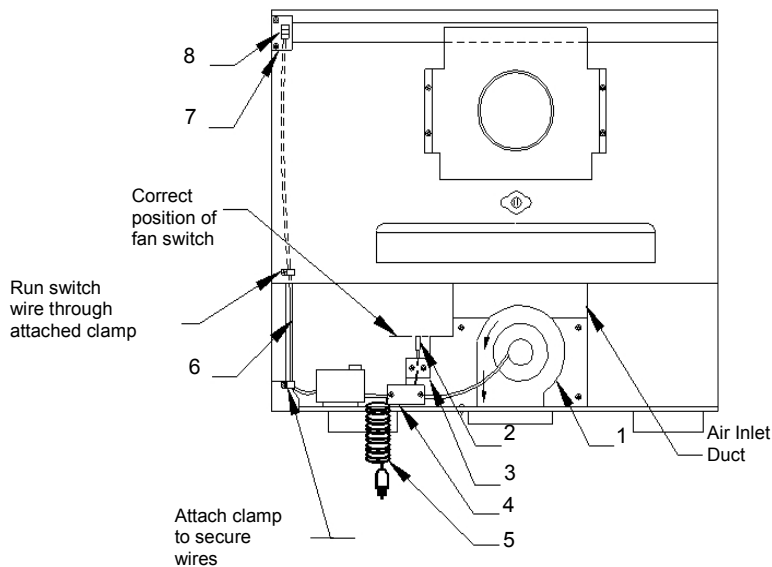

Reference Number	Part Number	Description
1	P501779	Motor
2	P323096	Fan Switch
3	K000862	Fan Switch Plate
4	90-01005-000-02	Junction Box
5	P501778	Cord and Plug
6	P202900	Wire (Red)
6	P202800	Wire (Black)
6	P202700	Wire (Blue)
7	K000862	Speed Switch Plate
8	P320911A	Speed Switch
Not shown	K000868	Switch Mounting Bracket – 500 Series
	K000870	Switch Mounting Bracket – 650 Series

# Troubleshooting

SYMPTOM	POSSIBLE CAUSE	CORRECTIVE ACTION
1. Pilot will not stay lit after following lighting instructions.	A. Generator producing insufficient millivolts.	Check pilot flame – it must impinge on the generator from 1/4 to 3/8-inches . Be sure the thermocouple is fully inserted in its bracket.
	B. Loose or dirty generator connections at gas valve.	Clean and/or tighten the connections at the valve.
	C. Generator defective.	Check the generator with millivolt meter. Take reading at the generator terminals of the valve with the valve placed in "Pilot" position. Disconnect the thermostat wires. The millivolt reading should be 450 millivolts or more.
	D. Grounded thermostat wire.	Remove the thermostat wires from the valve terminals. If the pilot now stays lit, trace the thermostat wiring circuit for a ground. May be grounded to heater, gas supply, nails or staples.
	E. Defective valve.	Replace the gas valve after above is verified.
2. Pilot burning - no gas to the main burner.	A. Thermostat not turned to a position calling for heat.	Set the thermostat to a position calling for heat.
	B. Plugged burner orifice.	Clean or replace.
	C. Improperly wired or broken thermostat wires. Defective thermostat.	Check the connections at valve terminals. If valve operates, check the thermostat wires.
	D. Pilot generator may not be generating sufficient millivoltage to open valve.	See 1A and 1C above.
	E. Defective valve.	Replace.
3. Burner comes "ON" but goes OFF before blower turns ON.	A. Thermostat location.	Check the thermostat location. It should not be in the path of warm air discharge from heater, near a lamp, or above a T.V. or stereo.
	B. Defective thermostat.	Check the thermostat calibration or replace.
4. Heater not producing sufficient heat.	A. Heater may be too small for space being heated.	Check heat sizing calculations.
	B. Heater not burning at full rate.	Check for low gas pressure at gas valve. It should be 4 inches W.C. for Natural Gas; 10.5 inches W.C. for L.P.G. Check for blocked burner orifice.

# Troubleshooting

SYMPTOM	POSSIBLE CAUSE	CORRECTIVE ACTION
5. Heater operates, but will not shut off after room temperature is attained.	A. Thermostat wiring defective.	Thermostat lead wires may be shorted together, caused by a nail or staple. Check by removing thermostat leads from valve terminals.
	B. Thermostat location.	Check thermostat location. If on an outside wall, or there is a hole in the wall behind thermostat, cold air may be coming in contact with the thermostat. Relocate the thermostat or plug the hole.
	C. Defective thermostat.	Verify thermostat temperature reading or replace.
	D. Valve stuck open.	Replace valve.
6. Pilot outage.	A. Pilot flame may be too low or blowing (high), causing pilot to drop out.	Adjust pilot flame. Pilot orifice may be plugged (Check for spider webs or other material).
	B. Drafts or drafty areas.	Check for doorway and high air movement areas.
7. Main burner will not stay on.	A. Blockage in vent pipe.	Checks vent pipe for blockage, such as bird nests, twigs, leaves, etc.
	B. Thermostat location.	Check thermostat location - if on an outside wall or there is a hole in wall behind the thermostat causing cold air to contact the thermostat, relocate the thermostat or plug the hole. Check that the vent cap is properly installed, and not placed too far down on the vent pipe. Cap must be the same manufacturer as the vent.
	C. Restriction in vent system caused by offsets.	All type "B" vents shall extend in a vertical direction with no more than two offsets not exceeding 45 degrees. Any angle greater than 45 degrees from vertical is considered horizontal. Any offsets used should be as far above the draft hood as possible to allow venting to begin before any restriction is encountered. The use of too many offsets may also prevent proper venting.
	D. Incorrect vent pipe.	Use listed B/W type vent pipe. DO NOT use transite or any other type of ceramic pipe for venting. DO NOT use single wall pipe. When venting into a masonry chimney, the chimney must be properly lined and sized for this gas heater. The use of type "B" or flexible chimney liner is recommended.
	E. Loose connections on the vent safety wiring harness.	Check the connection on both the switch and the gas valve. Tighten if necessary.

# Troubleshooting

8. Abnormal operation.	A. Delayed ignition - pilot flame may be too low.	Adjust pilot flame. Refer to "How to Care for Your Heater" section in this manual.
	B. Expansion noise, ticking.	Heater may be distorted by being vented through an uneven opening. A restricted vent may create expansion noise. Refer to "Venting" section of this manual.
	C. Combustible gas spillage.	Check vent system for a blocked flue, excessive down draft (wind) or negative pressure in room caused by ventilating fan or a fire in a fireplace.
	D. Excessive flame roll-out.	Heater is possibly overrated - check for high gas pressure at gas valve (see 4B).
	E. Burner is over-fired.	Check the manifold gas pressure. Check the rate, this appliance is manufactured for elevations up to 2,000 feet. It must be derated for operation above 2,000 feet.
	F. Yellow burner flame.	Check burner for obstructions. Install new burner and pilot orifices.
	G. Yellow pilot flame.	Remove pilot orifice, check and clean.
9. Noisy blower.	A. Housing rattling.	Tighten blower screws.
	B. Blower dirty.	Clean blower wheel.
	C. Blower wheel bent.	Straighten or replace.
10. Blower does not run.	A. Fan switch not set.	Select fan speed.
	B. Check bearings.	Add oil as outlined in "Blower Accessory Instructions".

# Hints and Information

## Service Hints

If your heater fails to work correctly, you may avoid the inconvenience and cost of a service call by checking the troubleshooting section on pages 29 thru 31 before you call for service.

**WARNING:** If the information in this manual is not followed exactly, a fire or explosion may result causing property damage, personal injury or loss of life.

**DO NOT** store or use gasoline or other flammable vapors and liquids in the vicinity of this or any other appliance.

### WHAT TO DO IF YOU SMELL GAS

- Open all of the windows.
- Do not try to light any appliance.
- Do not touch any electrical switch.
- Do not use any phone or cell phone in your building.
- Extinguish any open flame.
- Immediately call your gas supplier from a neighbor's phone. If you cannot reach your gas supplier, call the fire department.

Installation and service must be performed by a qualified installer, service agency or the gas supplier.

## How to Order Repair Parts

When ordering repair parts, always give the following information:

1. MODEL NUMBER
2. MFG. DATE CODE
3. PART NUMBER
4. PART DESCRIPTION

All parts listed herein may be ordered from your equipment supplier. The Model Number of your Williams heater will be found on the nameplate near the gas valve, inside the control compartment.



Williams Furnace Company • 250 West Laurel Street, Colton, CA 92324  
(909) 825-0993 • FAX: (909) 824-8009 • [www.wfc-fc.com](http://www.wfc-fc.com)

