

**CONFIGURATION**

The following table allows you to customize the options on your Comfort-Set thermostat. Begin by pressing simultaneously the two buttons in step 1.

Step	1F82-261 Press Button(s)	1F89-211 Press Button(s)	Displayed (Factory Default)	Press $\odot$ or $\ominus$ to select:	COMMENTS
1	PRGM and RUN	Set SYSTEM switch to OFF	HOLD (0:00)	0 to 8 hrs (in 15 minute increments)	Select temporary Hold time
2	HOLD*	$\odot$ or $\ominus$	* $\Phi$ (SL)	FA	Select FA or SL (Fast or Slow) pump cycle rate
3	HOLD*	$\odot$ or $\ominus$	EMER (FA)	SL	Select FA or SL (Fast or Slow) Auxiliary and Emergency Aux heating cycle rate
4	HOLD*	$\odot$ or $\ominus$	d-L (on)	OFF	Select display backlight OFF or ON
5	HOLD*	$\odot$ or $\ominus$	E (on)	OFF	Select Energy Management Recovery OFF or ON
6	HOLD*	$\odot$ or $\ominus$	Filter (000)	0 to 1950 hours (in 50 hour increments)	Select filter replacement run time
7	HOLD*	$\odot$ or $\ominus$	LOC (OFF)	on	Select Compressor lockout OFF or ON
8	HOLD*	$\odot$ or $\ominus$	0 HI (0)	4 LO to 4 HI	Select temperature display adjustment higher or lower
9	HOLD*	$\odot$ or $\ominus$	$^{\circ}$ (F)	$^{\circ}$ C	Select temperature display to $^{\circ}$ F or $^{\circ}$ C
10	HOLD*	$\odot$ or $\ominus$	FA (ON)	OFF	Selects fast second stage ON or OFF
11	RUN				Returns to normal operation

\* Press **HOLD** to advance to next item or **TIME** to move backwards to previous item

CLICK ANYWHERE on THIS PAGE to RETURN to WHITE RODGERS CONTROLS & MANUALS at InspectApedia.com

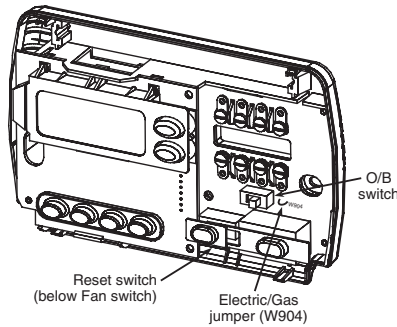

**Electric / Gas Jumper (Fan Option)**

If your emergency or auxiliary system will energize the blower, then jumper W904, on the thermostat base, must be cut (see figure at left). If your emergency or auxiliary heat system requires that the thermostat energize the fan circuit, do not cut jumper W904.

**O/B Terminal Switch Selection**

The O/B switch on this thermostat is factory set to the "O" position. This will accommodate the majority of heat pump applications, which require the changeover relay to be energized in COOL. If the thermostat you are replacing or the heat pump being installed with this thermostat requires a "B" terminal, to energize the changeover relay in HEAT, the O/B switch must be moved to the "B" position.

**TYPICAL WIRING DIAGRAMS**

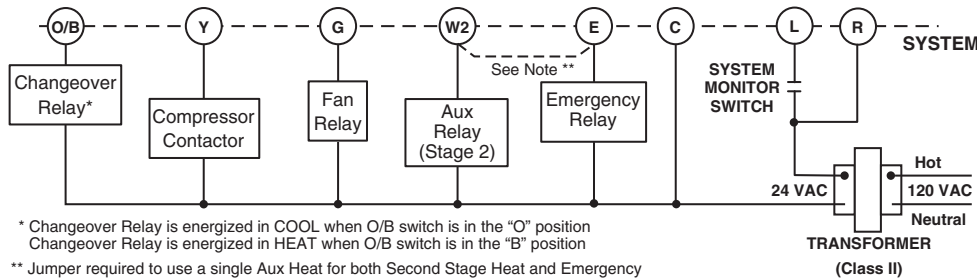

\* Changeover Relay is energized in COOL when O/B switch is in the "O" position  
Changeover Relay is energized in HEAT when O/B switch is in the "B" position

\*\* Jumper required to use a single Aux Heat for both Second Stage Heat and Emergency

**Single transformer systems**

**NOTE**  
If safety circuits are in only one of the systems, remove the transformer of the system with **NO** safety circuits.

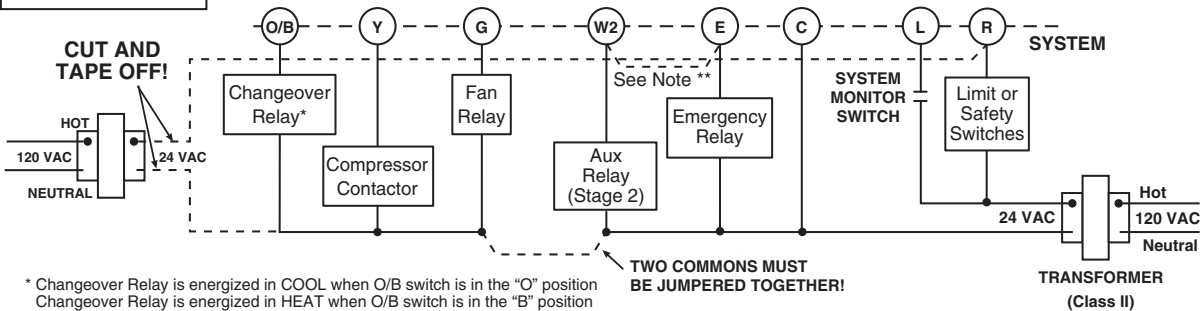

\* Changeover Relay is energized in COOL when O/B switch is in the "O" position  
Changeover Relay is energized in HEAT when O/B switch is in the "B" position

\*\* Jumper required to use a single Aux Heat for both Second Stage Heat and Emergency

**Two transformer systems with NO safety circuits**