



# Ultra

Gas-fired  
Water boiler  
Series 2

## Boiler Manual

### Ultra-80, -105, -155, -230 & -310

#### NOTICE:

##### Series 1/Series 2 identification

Read the boiler rating plate to determine the series number. The rating plate is located on the right side of the boiler.



- Installation
- Startup
- Maintenance
- Parts



Ultra  
with **PhD** PRECISION  
HYDRONIC  
DATA technology

#### WARNING

This manual must only be used by a qualified heating installer/service technician. Read all instructions, including this manual, the Ultra Control Supplement and the Ultra Vent Supplement, before installing. Perform steps in the order given. Failure to comply could result in severe personal injury, death or substantial property damage.

## THE *Ultra* BOILER, WITH PhD TECHNOLOGY — HOW IT WORKS . . .

### PhD technology

PhD Technology, Precision hydronic Data, is an intelligent system that delivers Precision hydronic heating and hot water needs while maximizing efficiency by measuring the Data parameters of your heating system.

#### 1. Cast aluminum heat exchanger

#### 2. Heat exchanger access cover

#### 3. Blower

The advanced blower design and air inlet silencer (5a) on Ultra boilers result in very quiet operation.

80 & 105 — Air enters the boiler enclosure through the air intake adapter (18), flows through the enclosure, enters the air inlet silencer (5a), then enters the blower. The blower pulls air through the silencer and pushes it into the venturi (5), where it mixes with gas before entering the burner.

155, 230 & 310 — Air enters the boiler enclosure through the air intake adapter (18), flows through the enclosure, enters the air inlet silencer (5a), then enters the venturi (5). The blower pulls air and gas through the venturi and pushes the mixture into the burner.

#### 4. Gas valve

The gas valve senses the vacuum in the venturi caused by flowing air, and allows gas to flow when power is applied. The manual gas valve (4a) allows shutting off the gas supply for servicing or shutdown. Models 80 and 105 use a sensing line (4b) from the gas valve to the blower outlet so the gas valve references the same pressure as the venturi inlet.

#### 5. Venturi

When air flows through the venturi, it creates a vacuum. This vacuum pulls gas from the gas valve. So gas will only flow if air is flowing. On 80 and 105 models, the gas air mixture enters the burner after the venturi. On 155, 230 and 310 models, the gas/air mixture enters the blower before passing on to the burner.

#### 6. Flue gas sensor

This sensor monitors the flue gas exit temperature. The control module will shut down the boiler if flue gas temperature gets too hot. This protects the flue pipe and the heat exchanger from overheating.

#### 7. Outlet water temperature sensor

This sensor monitors boiler outlet water temperature (system supply). The control module adjusts boiler firing rate so the outlet temperature is correct.

#### 8. Return water temperature sensor

This sensor monitors return water temperature (system return). The control module reduces or increases boiler input, depending on how close the return water temperature is to the outlet water temperature.

#### 9. Temperature and pressure gauge

#### 10. Electronic display & buttons

The 4-digit electronic display is used to:

- Set space heating temperature.
- Show outlet water temperature (normal) or other operating conditions (in Information mode).
- Show boiler status and shutdown or lockout codes for easy troubleshooting.

The buttons allow changing display mode and reset after lockout. The on/off Power switch (10a) turns power to the boiler controls on or off.

#### 11. Flue pipe adapter

#### 12. Burner

Made with high-grade stainless steel construction, the burner uses pre-mixed air and gas and provides a wide range of firing rates.

#### 13. Water outlet pipe (system supply)

#### 14. Water return pipe (system return)

#### 15. Gas connection pipe

#### 16. *Ultra* Control Module

The *Ultra* Control Module responds to signals from the room thermostat, supply water sensor, return water sensor, flue gas sensor and (if used): domestic hot water aquastat, outdoor temperature sensor, and summer/winter switch. The control module automatically adjusts blower speed (and gas flow rate) to match boiler output to space heating and/or DHW heating demand. The control module is accessed by removing top front cover (16a).

#### 17. Transformer

The transformer reduces line voltage from 120 vac to 24 vac, providing 24 vac to the control module for the gas valve and blower signal.

#### 18. Air intake adapter

#### 19. Electrical entrance cover plate

Remove the electrical cover plate to access the line voltage terminal strip (19b) and the low voltage terminal strip (19a). Attach line voltage conduits to the three holes at the left of the line voltage terminal strip for power, CH pump and DHW pump. Route low voltage wires through the opening to the right of the low voltage terminal strip.

#### 20. Boiler drain valve

#### 21. Line voltage receptacle

Use this connection to plug in line voltage meters or tools while working on boiler. Do not exceed 10-amp load.

#### 22. P/T gauge temperature sensor well

The remote sensor for the panel-mounted pressure/temperature gauge inserts into the outlet water pipe here.

#### 23. Flue gas condensate drain connection

Connect condensate drain line to ½" PVC tee here. The condensate trap (23a) and PVC fittings are field-installed.

#### 24. Front door

The front door is sealed to the boiler assembly around its entire perimeter. Two knurled-head screws (24a) secure the door in place.

#### 25. Ignition electrode

The burner flame is ignited by applying a high voltage to the ignition electrode. This causes a spark (from electrode to ground).

#### 26. Flame inspection window

The quartz glass window provides a view of the burner surface and flame.

#### 27. Data port

External connection to MCBA control for computer interface.

THE *Ultra* GAS-FIRED WATER BOILER, WITH **PhD** TECHNOLOGY

**Ultra-80 & 105** (front door removed)

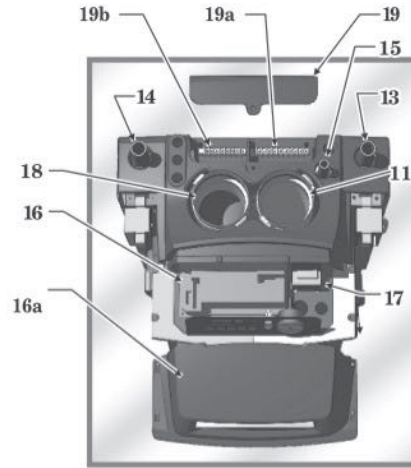
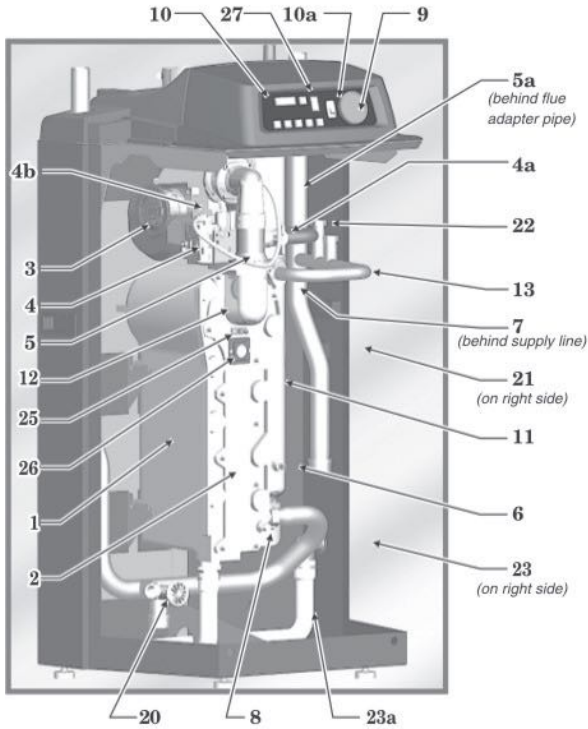

Top (parts removed for clarity)

**All models**

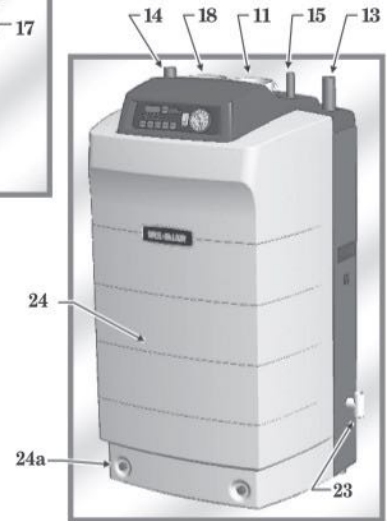

Front (jacket front installed)

**Ultra-155 & 230** (front door removed)

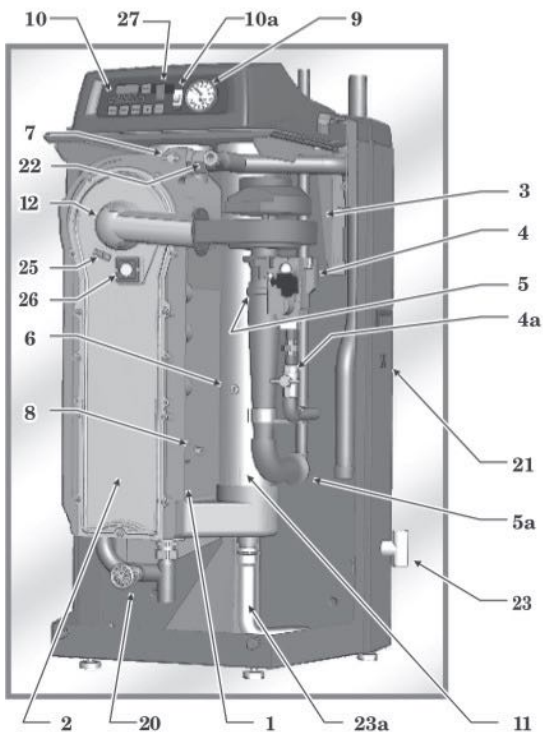

**Ultra-310** (front door removed)

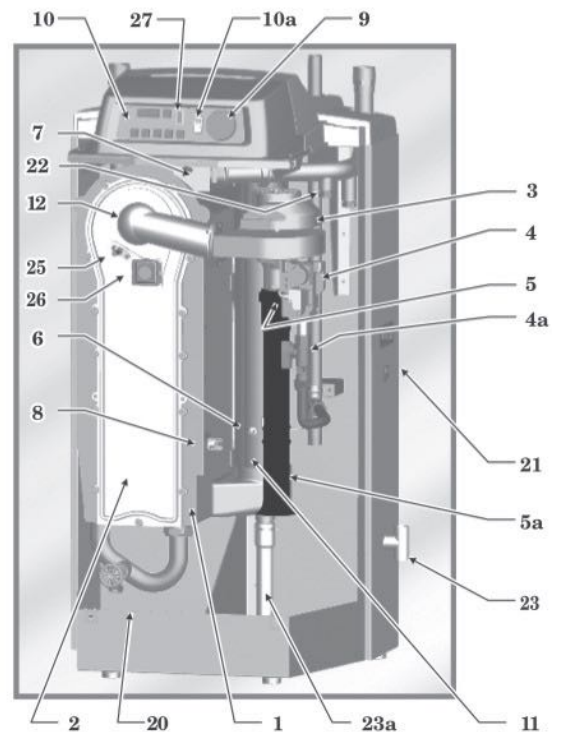

U001

## Contents

How it works .....	2–3
Hazard definitions .....	4
Please read before proceeding .....	5
1 Prepare boiler location .....	6
2 Prepare boiler .....	9
3 Install water piping .....	12
4 Venting, combustion air & condensate line .....	19
5 Gas piping .....	21
6 Startup ( <i>Note 1</i> ) .....	23
7 Check-out/startup verification .....	26
8 Annual startup and general maintenance .....	28
9 Replacement parts .....	35
10 Dimensions .....	43
11 Ratings .....	44

*Note 1:* See Ultra Control Supplement for wiring and additional startup and operating information.

---

## Hazard definitions

The following defined terms are used throughout this manual to bring attention to the presence of hazards of various risk levels or to important information concerning the life of the product.

**DANGER** Indicates presence of hazards that will cause severe personal injury, death or substantial property damage.

**WARNING** Indicates presence of hazards that can cause severe personal injury, death or substantial property damage.

**CAUTION** Indicates presence of hazards that will or can cause minor personal injury or property damage.

**NOTICE** Indicates special instructions on installation, operation or maintenance that are important but not related to personal injury or property damage.

## Please read before proceeding

### WARNING

**Installer**— Read all instructions, including this manual, the Ultra Control Supplement and Ultra Vent Supplement, before installing. Perform steps in the order given.

**User** — This manual is for use only by a qualified heating installer/service technician. Refer to User's Information Manual for your reference.

**User** — Have this boiler serviced/inspected by a qualified service technician, at least annually.

Failure to comply with the above could result in severe personal injury, death or substantial property damage.

### WARNING

The boiler contains ceramic fiber materials. Use care when handling these materials per instructions on page 29 of this manual. Failure to comply could result in severe personal injury.

### NOTICE

When calling or writing about the boiler— Please have the boiler model number from the boiler rating label and the CP number from the boiler jacket. You may list the CP number in the space provided on the Installation and service certificate found on page 27.

Consider piping and installation when determining boiler location.

Any claims for damage or shortage in shipment must be filed immediately against the transportation company by the consignee.

### Commonwealth of Massachusetts

When the boiler is installed within the Commonwealth of Massachusetts:

- This product must be installed by a licensed plumber or gas fitter.
- If antifreeze is used, a reduced pressure back-flow preventer device shall be used.

### WARNING

Failure to adhere to the guidelines on this page can result in severe personal injury, death or substantial property damage.

### When servicing boiler —

- To avoid electric shock, disconnect electrical supply before performing maintenance.
- To avoid severe burns, allow boiler to cool before performing maintenance.

### Boiler operation —

- Do not block flow of combustion or ventilation air to boiler.
- Should overheating occur or gas supply fail to shut off, do not turn off or disconnect electrical supply to circulator. Instead, shut off the gas supply at a location external to the appliance.
- Do not use this boiler if any part has been under water. Immediately call a qualified service technician to inspect the boiler and to replace any part of the control system and any gas control that has been under water.

### Boiler water —

- The Ultra heat exchanger is made of aluminum, and requires that system pH always be between 7.0 and 8.5 and water chemistry be checked. Chemical treatment may be necessary. See page 24 for details.
- Thoroughly flush the system (without boiler connected) to remove sediment. The high-efficiency heat exchanger can be damaged by build-up or corrosion due to sediment.
- Do not use petroleum-based cleaning or sealing compounds in boiler system. Gaskets and seals in the system may be damaged. This can result in substantial property damage.
- Do not use “homemade cures” or “boiler patent medicines.” Serious damage to boiler, personnel and/or property may result.
- Continual fresh make-up water will reduce boiler life. Mineral buildup in heat exchanger reduces heat transfer, overheats the aluminum heat exchanger, and causes failure. Addition of oxygen carried in by make-up water can cause internal corrosion. Leaks in boiler or piping must be repaired at once to prevent make-up water.
- Do not add cold water to hot boiler. Thermal shock can cause heat exchanger to crack.

### Freeze protection fluids —

NEVER use automotive or standard glycol antifreeze, even glycol made for hydronic systems. Use only freeze-protection fluids recommended in the Ultra Boiler Freeze Protection Supplement.

Follow all guidelines in the Ultra Boiler Freeze Protection Supplement. Thoroughly clean and flush any replacement boiler system that has used glycol before installing the new Ultra boiler.

## Prepare boiler location

### Installations must comply with:

- Local, state, provincial, and national codes, laws, regulations and ordinances.
- National Fuel Gas Code, ANSI Z223.1 – latest edition.
- Standard for Controls and Safety Devices for Automatically Fired Boilers, ANSI/ASME CSD-1, when required.
- National Electrical Code.
- For Canada only: B149.1 or B149.2 Installation Code, CSA C22.1 Canadian Electrical Code Part 1 and any local codes.

#### NOTICE

The Ultra boiler gas manifold and controls met safe lighting and other performance criteria when boiler underwent tests specified in ANSI Z21.13 — latest edition.

### Before locating the boiler, check:

1. Check for nearby connection to:
  - System water piping
  - Venting connections
  - Gas supply piping
  - Electrical power
2. Check area around boiler. Remove any combustible materials, gasoline and other flammable liquids.

#### WARNING

Failure to keep boiler area clear and free of combustible materials, gasoline and other flammable liquids and vapors can result in severe personal injury, death or substantial property damage.

3. The Ultra boiler must be installed so that gas control system components are protected from dripping or spraying water or rain during operation or service.
4. If new boiler will replace existing boiler, check for and correct system problems, such as:
  - System leaks causing oxygen corrosion or heat exchanger cracks from hard water deposits.
  - Incorrectly-sized expansion tank.
  - Lack of freeze protection in boiler water causing system and boiler to freeze and leak.

### Provide clearances:

#### Clearances from combustible materials

1. Hot water pipes — at least ½" from combustible materials.
2. Vent pipe — at least 0.20" from combustible materials.
3. See Figure 1 for other clearance minimums.

#### Clearances for service access

1. See Figure 1 for recommended service clearances. If you do not provide minimum clearances shown, it might not be possible to service the boiler without removing it from the space.

#### NOTICE

Ultra boilers, except the Ultra-310, may be wall mounted (using special wall mount kit) or floor mounted. No clearance is required at the rear of the unit, either for service or for clearance to combustible surfaces.

**Figure 1** Clearances required

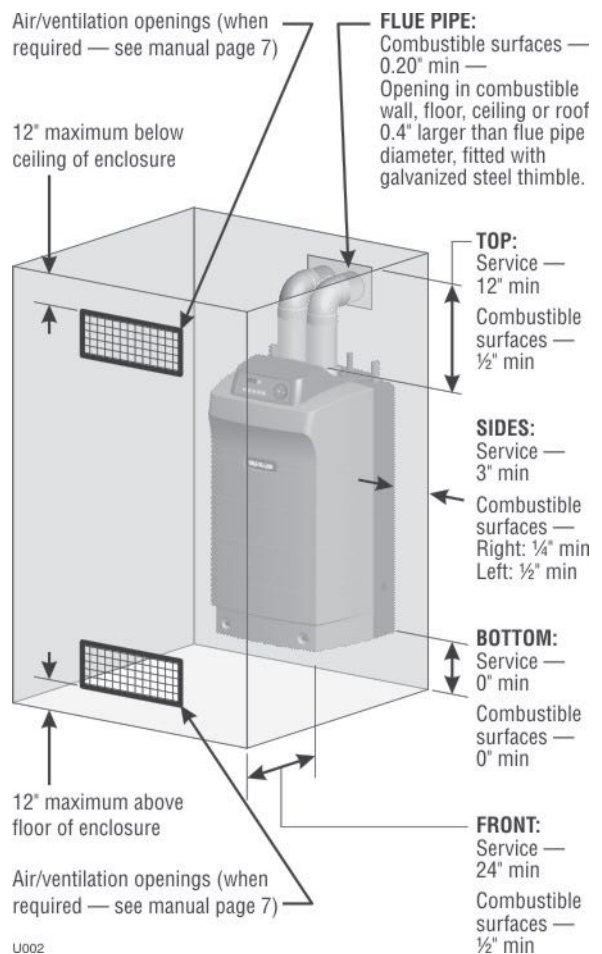

## Prepare boiler location *(continued)*

### Flooring and foundation

#### Flooring

The Ultra boiler is approved for installation on combustible flooring, but must never be installed on carpeting.

**WARNING** Do not install boiler on carpeting even if foundation is used. Fire can result, causing severe personal injury, death or substantial property damage.

#### Foundation

Provide a solid foundation pad, at least 2 inches above the floor, if any of the following is true:

- floor can become flooded.
- the floor is dirt, sand, gravel or other loose material.
- the boiler mounting area is severely uneven or sloped.

The minimum foundation size is:

- Ultra-80 to -230: 24 inches wide x 20 inches deep.
- Ultra-310: 24 inches wide x 23 inches deep

Foundation may be of wood, brick or concrete (minimum 2 inches thick) construction.

If flooding is possible, elevate boiler sufficiently to prevent water from reaching boiler.

### Residential garage installation

#### Precautions

Take the following special precautions when installing the boiler in a residential garage. If the boiler is located in a residential garage, per ANSI Z223.1, paragraph 5.1.9:

- Mount the boiler with a minimum of 18 inches above the floor of the garage to the bottom of the boiler to ensure the burner and ignition devices will be no less than 18 inches above the floor.
- Locate or protect the boiler so it cannot be damaged by a moving vehicle.

### Provide air openings to room:

#### Ultra boiler alone in boiler room

1. No air ventilation openings into boiler room are needed when clearances around Ultra boiler are at least equal to the SERVICE clearances shown in Figure 1. For spaces that do NOT supply this clearance, provide two openings as shown in Figure 1. Each opening must provide 1 square inch free area per 1,000 Btuh of boiler input.

### Ultra boiler in same space with other gas or oil-fired appliances

1. Follow the National Fuel Gas Code (U. S.) or CSA B149.1 and B149.2 (Canada) to size/verify size of the combustion/ventilation air openings into the space.

#### WARNING

The space must be provided with combustion/ventilation air openings correctly sized for all other appliances located in the same space as the Ultra boiler.

Replace boiler jacket front door after servicing. The boiler front door must be securely fastened to the boiler to prevent boiler from drawing air from inside the boiler room. This is particularly important if the boiler is located in the same room as other appliances.

Failure to comply with the above warnings could result in severe personal injury, death or substantial property damage.

2. Size openings only on the basis of the other appliances in the space. No additional air opening free area is needed for the Ultra boiler because it takes its combustion air from outside (direct vent installation).

### Vent and air piping

The Ultra boiler requires a special vent system, designed for pressurized venting. Ultra boilers are rated ANSI Z21.13 Category IV (pressurized vent, likely to condense in the vent).

You must also install air piping from outside to the boiler air intake adapter. The resultant installation is categorized as direct vent (sealed combustion). Note prevention of combustion air contamination on page 8 when considering vent/air termination.

Vent and air must terminate near one another and may be vented vertically through the roof or out a side wall. You may use any of the vent/air piping methods covered in the Ultra Boiler Vent Supplement, included in the envelope assembly. Do not attempt to install the Ultra boiler using any other means.

Be sure to locate the boiler such that the vent and air piping can be routed through the building and properly terminated. The vent/air piping lengths, routing and

## Prepare boiler location *(continued)*

### Prevent combustion air contamination

Install air inlet piping for the Ultra boiler as described in the Ultra Boiler Vent Supplement. Do not terminate vent/air in locations that can allow contamination of combustion air. Refer to Table 1 for products and areas which may cause contaminated combustion air.

**WARNING** You must pipe combustion air to the boiler air intake. Ensure that the combustion air will not contain any of the contaminants below. Contaminated combustion air will damage the boiler, resulting in possible severe personal injury, death or substantial property damage. Do not pipe combustion air near a swimming pool, for example. Also avoid areas subject to exhaust fumes from laundry facilities. These areas will always contain contaminants.

**Table 1** Corrosive contaminants and sources

Products to avoid
Spray cans containing chloro/fluorocarbons
Permanent wave solutions
Chlorinated waxes/cleaners
Chlorine-based swimming pool chemicals
Calcium chloride used for thawing
Sodium chloride used for water softening
Refrigerant leaks
Paint or varnish removers
Hydrochloric acid/muriatic acid
Cements and glues
Antistatic fabric softeners used in clothes dryers
Chlorine-type bleaches, detergents, and cleaning solvents found in household laundry rooms
Adhesives used to fasten building products and other similar products
Areas likely to have contaminants
Dry cleaning/laundry areas and establishments
Swimming pools
Metal fabrication plants
Beauty shops
Refrigeration repair shops
Photo processing plants
Auto body shops
Plastic manufacturing plants
Furniture refinishing areas and establishments
New building construction
Remodeling areas
Garages with workshops

### When removing a boiler from existing common vent system:

**DANGER** Do not install the Ultra boiler into a common vent with any other appliance. This will cause flue gas spillage or appliance malfunction, resulting in possible severe personal injury, death or substantial property damage.

**WARNING** Failure to follow all instructions can result in flue gas spillage and carbon monoxide emissions, causing severe personal injury or death.

At the time of removal of an existing boiler, the following steps shall be followed with each appliance remaining connected to the common venting system placed in operation, while the other appliances remaining connected to the common venting system are not in operation.

- a. Seal any unused openings in the common venting system.
- b. Visually inspect the venting system for proper size and horizontal pitch and determine there is no blockage or restriction, leakage, corrosion or other deficiencies which could cause an unsafe condition.
- c. Test vent system — Insofar as is practical, close all building doors and windows and all doors between the space in which the appliances remaining connected to the common venting system are located and other spaces of the building. Turn on clothes dryers and any appliance not connected to the common venting system. Turn on any exhaust fans, such as range hoods and bathroom exhausts, so they will operate at maximum speed. Do not operate a summer exhaust fan. Close fireplace dampers.
- d. Place in operation the appliance being inspected. Follow the lighting instructions. Adjust thermostat so appliance will operate continuously.
- e. Test for spillage at draft hood relief opening after 5 minutes of main burner operation. Use the flame of a match or candle, or smoke from a cigarette, cigar, or pipe.
- f. After it has been determined that each appliance remaining connected to the common venting system properly vents when tested as outlined herein, return doors, windows, exhaust fans, fireplace dampers, and any other gas-burning appliance to their previous conditions of use.

Any improper operation of common venting system should be corrected so the installation conforms with the National Fuel Gas Code, ANSI Z223.1 — latest edition. Correct by resizing to approach the minimum size as determined using the appropriate tables in Part 11 of that code. Canadian installations must comply with B149.1 or B149.2 Installation Code.



## Prepare boiler

### Remove boiler from crate

**CAUTION** Cold weather handling — If boiler has been stored in a very cold location (below 0°F) before installation, handle with care until the plastic components come to room temperature.

1. The Ultra boiler is generally easier to handle and maneuver after removing from crate.
2. After removing outer shipping carton from boiler, REMOVE jacket front door by loosening two knurled-head screws at lower front. Removing the door will prevent possible damage to the door during handling.
3. To remove boiler from pallet (after removing jacket front door):
  - a. Remove the four lag screws securing shipping brackets.
  - b. Unscrew the two rear boiler legs and remove the shipping brackets.
  - c. Replace legs.
  - d. Discard the cardboard protector insert on the rear of the boiler.

**NOTICE** Do not drop boiler or bump jacket on floor or pallet. Damage to boiler can result.

### Ultra-80 Series 1 and 2 ONLY Propane operation

**WARNING** **Ultra-80: DO NOT** apply the propane conversion instructions in this manual to Ultra-80 boilers. Follow the instructions provided with the optional propane conversion kit.

The propane conversion kit is **NOT** included as standard equipment for the Ultra-80.

**NOTICE** **Ultra-80-LP** boilers are factory-equipped to operate on propane gas.

### Ultra-310 Series 1 Boilers ONLY Propane operation

**WARNING** **Ultra-310 Series 1: DO NOT** apply the propane conversion instructions in this manual to Ultra-310 **Series 1** boilers. Follow the instructions provided with the optional propane conversion kit.

**NOTICE** The propane conversion kit is **NOT** included as standard equipment for the Model Ultra-310 **Series 1**.

*See the next page for Ultra-310 Series 2 and all Ultra-155 and Ultra-230 model propane instructions.*

### Ultra-105 Series 1 and 2 ONLY Prepare for propane operation

**WARNING** Do not apply the following to conversion of a boiler already installed and connected to gas supply. For a boiler already installed, you must turn off gas supply, turn off power and allow boiler to cool before proceeding. You must also completely test the boiler after conversion to verify performance as described under “Startup,” Section 6 of this manual. See separate natural to propane conversion instructions for conversion of an existing boiler.

You must install the propane orifice to fire the Ultra boiler on propane. Verify when installing that the orifice size marking matches boiler size. Failure to comply could result in severe personal injury, death or substantial property damage.

1. With boiler on its back, remove jacket front door by removing two knurled head screws at lower front. Then lift door away from boiler.
2. Disconnect the gas valve electrical plug.
3. Remove the 4 screws securing gas valve inlet adapter to valve.
4. Remove (3) TORX screws securing gas valve to venturi (Figure 2).
5. Locate propane orifice disc from conversion kit bag. Verify that the stamping on the orifice disk matches the boiler size. Place orifice in the black rubber grommet in the side of the gas valve and secure in valve (Figure 2).
6. Reposition gas valve against venturi and replace (3) TORX screws securing valve to venturi. Secure gas valve inlet adapter to gas valve with 4 screws. Make sure the plastic hose is connected from gas valve to inlet elbow.

**DANGER** Inspect the O-ring between the gas valve and gas valve inlet adapter block whenever they are disassembled. The O-ring must be in good condition and must be installed. Failure to comply will cause a gas leak, resulting in severe personal injury or death.

7. DO NOT attempt to adjust gas valve outlet pressure.
8. Connect gas valve electrical plug to valve terminals.
9. After installation is complete, attach the propane conversion label (in conversion kit bag) next to the boiler rating plate.
10. Replace jacket front panel.

**Figure 2** Installing propane orifice (**Ultra-105 boiler ONLY**)

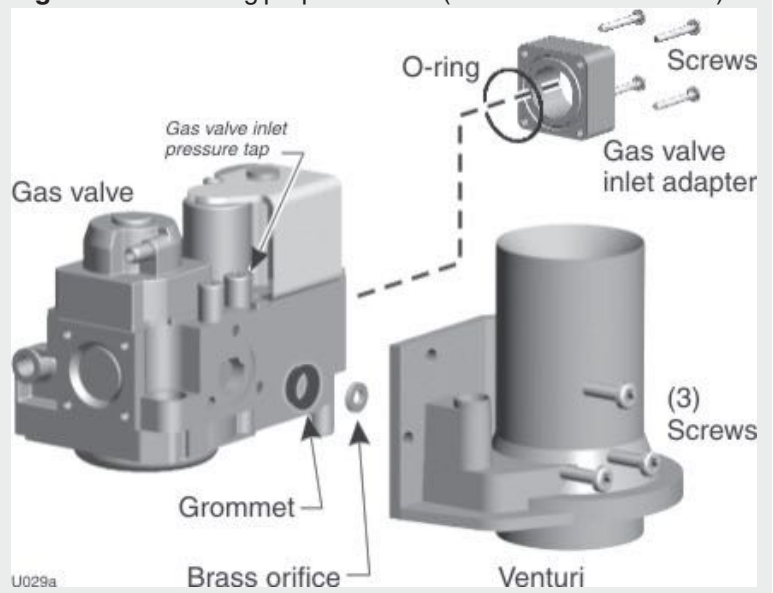

## Prepare boiler *(continued)*

### Ultra-310 Series 2 Ultra-155 Series 1 and 2 Ultra-230 Series 1 and 2 Prepare for propane operation

#### WARNING

Do not apply the following to conversion of a boiler already installed and connected to gas supply. For a boiler already installed, you must turn off gas supply, turn off power and allow boiler to cool before proceeding. You must also completely test the boiler after conversion to verify performance as described under “Startup,” Section 6 of this manual. See separate natural to propane conversion instructions for conversion of an existing boiler.

You must install the propane orifice to fire the Ultra boiler on propane. Verify when installing that the orifice size marking matches boiler size. Failure to comply could result in severe personal injury, death or substantial property damage.

1. With boiler on its back, remove jacket front door by removing two knurled head screws at lower front. Then lift door away from boiler.
2. Disconnect the gas valve electrical plug.
3. Disconnect the gas line union below the gas valve.
4. Remove (3) TORX screws securing gas valve to venturi (Figure 2a).
5. Locate propane orifice disc from conversion kit bag. Verify that the stamping on the orifice disk matches the boiler size. Place orifice in the black rubber grommet in the side of the gas valve and secure in valve (Figure 2a).
6. Reposition gas valve against venturi and replace (3) TORX screws securing valve to venturi. Reconnect gas line union.
7. DO NOT attempt to adjust gas valve outlet pressure.
8. Connect gas valve electrical plug to valve terminals.
9. After installation is complete, attach the propane conversion label (in conversion kit bag) next to the boiler rating plate.
10. Replace jacket front panel.

*See the previous page for Ultra-310 Series 1 and all Ultra-80 and Ultra-105 model propane instructions.*

### Placing floor-mounted boilers

1. Set boiler in place and check level.
  - a. Adjust legs, if necessary to level boiler.

### Placing wall-mounted boilers

1. Ultra-80, -105, -155 and -230 boilers can be wall mounted. Use only the separately available Ultra boiler wall mounting kit and instructions. See WARNING below.

#### WARNING

The wall must be vertically plumb and capable of carrying the weight of the boiler. The operating weights are:

Ultra-80: 139 pounds.

Ultra-105: 145 pounds.

Ultra-155: 181 pounds.

Ultra-230: 192 pounds.

Model Ultra-310 boilers are NOT designed for wall mounting.

Wall mount Ultra boilers only using Weil-McLain Ultra boiler wall-mounting kit and accompanying instructions. This kit is not supplied as standard equipment with the boiler, and must be purchased separately.

Failure to comply with above could result in severe personal injury, death or substantial property damage.

**Figure 2a** Installing propane orifice (Ultra-155, Ultra-230 & Ultra-310 Series 2)

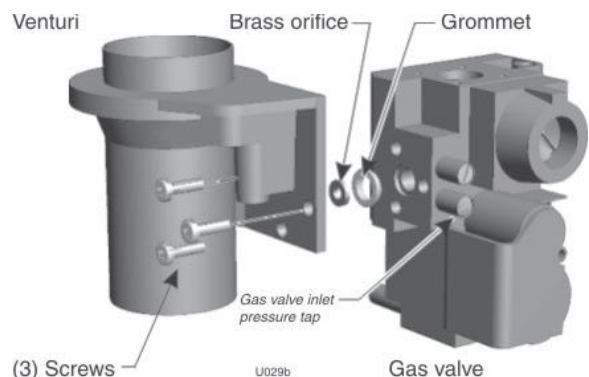

## Prepare boiler *(continued)*

### Perform hydrostatic pressure test

Pressure test boiler before permanently attaching water or gas piping or electrical supply.

### Prepare boiler for test

1. See Figure 3 for reference in following steps.
2. Remove supply line tee\* and  $\frac{3}{4}$ " street elbow from accessory bag. Pipe to boiler supply connection as shown. Use pipe dope sparingly. (\*1" x 1" x  $\frac{3}{4}$ " tee with Ultra-80 to -230 or  $1\frac{1}{4}$ " x  $1\frac{1}{4}$ " x  $\frac{3}{4}$ " tee with Ultra-310)
3. Temporarily plug the  $\frac{3}{4}$ " relief valve tapping in the street elbow with a  $\frac{3}{4}$ " NPT pipe plug.
4. Connect a hose to boiler drain valve, the other end connected to a fresh water supply. Make sure hose can also be used to drain boiler after test.
5. Connect a nipple and shutoff valve to system supply connection on the supply tee. This valve will be used to bleed air during the fill. (Valve and nipple are not included with boiler.)
6. Connect a shutoff valve to system return connection. (Valve is not included with boiler.)
7. To avoid getting water on boiler, you may want to pipe street elbows on top of shutoff valves and attach catch-buckets beneath.
8. If convenient, install the boiler circulator and any other piping compatible with Figure 3 that would still allow bleeding air from shutoff valves. Follow guidelines in this manual for piping components, locations and sizing.

### Fill and pressure test

1. Open the shutoff valves you installed on supply and return connections.
2. Slowly open boiler drain valve and fresh water supply to fill boiler with water. The boiler will fill quickly because of its low water content.
3. When water reaches shutoff valves, close boiler drain valve.
4. Close shutoff valves.
5. Slowly reopen boiler drain valve until test pressure on the pressure/temperature gauge reaches at least 45 psig, but no higher than 55 psig.
6. Hold at test pressure for 10 minutes.

**WARNING** Do not leave boiler unattended. A cold water fill could expand and cause excessive pressure, resulting in severe personal injury, death or substantial property damage.

7. Make sure constant gauge pressure has been maintained throughout test. Check for leaks. Repair if found.

#### WARNING

Leaks must be repaired at once. Failure to do so can damage boiler, resulting in substantial property damage.

#### WARNING

Do not use petroleum-based cleaning or sealing compounds in boiler system. Gaskets and seals in the system may be damaged. This can result in substantial property damage.

### Drain and remove fittings

1. Disconnect fill water hose from water source.
2. Drain boiler through drain valve. Remove hose after draining.
3. Remove nipples and valves unless they will remain for use in the system piping.
4. Remove plug from relief valve street elbow. See section 3 (page 12) to install relief valve.

**Figure 3** Hydrostatic test piping connections

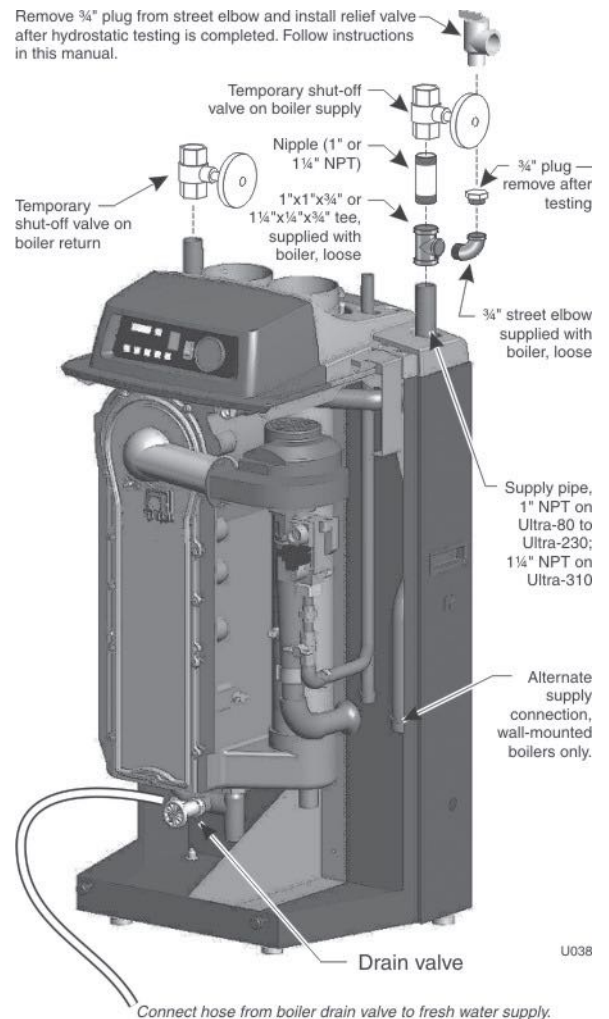

## Install water piping

### Install relief valve

1. Install relief valve in ¾" street elbow piped from boiler supply piping tee (Figure 3, page 11). Pipe the relief valve only as shown, in the location shown.
2. Connect discharge piping to safe disposal location, following guidelines in the WARNING below.

**WARNING** To avoid water damage or scalding due to relief valve operation:

- Discharge line must be connected to relief valve outlet and run to a safe place of disposal. Terminate the discharge line in a manner that will prevent possibility of severe burns or property damage should the valve discharge.
- Discharge line must be as short as possible and be the same size as the valve discharge connection throughout its entire length.
- Discharge line must pitch downward from the valve and terminate at least 6" above the floor drain where any discharge will be clearly visible.
- The discharge line shall terminate plain, not threaded, with a material serviceable for temperatures of 375 °F or greater.
- Do not pipe the discharge to any place where freezing could occur.
- No shutoff valve shall be installed between the relief valve and boiler, or in the discharge line. Do not plug or place any obstruction in the discharge line.
- Test the operation of the valve after filling and pressurizing system by lifting the lever. Make sure the valve discharges freely. If the valve fails to operate correctly, replace it with a new relief valve.
- Failure to comply with the above guidelines could result in failure of the relief valve to operate, resulting in possibility of severe personal injury, death or substantial property damage.

**WARNING** Use two wrenches when tightening water piping at boiler, using one wrench to prevent the boiler return line or supply line from turning. Failure to support the boiler piping connections to prevent them from turning could cause damage to boiler components.

### General piping information

#### Additional controls, when required

**NOTICE**

The Ultra control module uses temperature sensors to provide both high limit protection and modulating temperature control. The control module also provides low water protection by sensing the temperature of the heat exchanger. Some codes/jurisdictions may require additional external controls for high limit and/or low water cutoff protection.

#### Additional limit control:

Following standard industry practices, if installation is to comply with ASME or Canadian requirements, an additional high temperature limit is needed. Consult local requirements for other codes/standards to determine if needed.

1. Install additional high temperature limit constructed to prevent a temperature setting above 200°F in system supply piping between boiler and isolation valve. (Note that the Ultra control module operating limit function shuts the boiler down at 190°F or Parameter 4, whichever is lower.)
2. See Ultra Control Supplement for wiring.
  - a. If limit control is to cause a boiler hard lockout (requiring manual reset of Ultra control module), connect isolated contact to field control wiring terminals 6 and 8 as shown in wiring diagram.
  - b. Otherwise, connect isolated contact between terminals 6 and 7 for a soft lockout (automatic reset).
  - c. If using a manual reset limit control or wiring in the manual reset circuit, Parameter 4 should be no closer than 20°F to the limit control setting (i.e., no higher than 180°F for a 200°F limit setting, for example).

#### Separate low water cutoff:

A low water cutoff device is required when boiler is installed above piping level or by certain state or local codes or insurance companies. Consult local requirements to determine.

1. If required, use a low water cutoff designed for water installations. Electrode probe-type is recommended.
2. Purchase low water cutoff and install in tee in supply piping above boiler.
3. See Ultra Control Supplement for wiring.
  - a. If limit control is to cause a boiler hard lockout (requiring manual reset of Ultra control module), connect isolated contact to field control wiring terminals 6 and 8 as shown in wiring diagram.
  - b. Otherwise, connect isolated contact between terminals 6 and 7 for a soft lockout (automatic reset).

#### Backflow preventer:

Use backflow check valve in cold water supply as required by local codes.

## Install water piping *(continued)*

### System water piping methods

#### NOTICE

All piping methods shown in this manual use primary/secondary connection to the boiler loop. These designs ensure proper flow through the Ultra boiler, for the most efficient and reliable operation of the boiler and the heating system. For other piping methods, consult your local Weil-McLain representative or refer to separate Ultra boiler piping guides.

Wall-mounted boilers — Piping can exit bottom of boiler enclosure. See separate wall-mounting instructions for details.

### Expansion tank and make-up water

1. Ensure expansion tank size will handle boiler and system water volume and temperature. Allow 3 gallons for boiler and its piping.

#### CAUTION

Undersized expansion tanks cause system water to be lost from relief valve and make-up water to be added through fill valve. Eventual boiler failure can result due to excessive make-up water addition.

2. Tank must be located as shown in this manual, or following recognized design methods. See tank manufacturer's instructions for details.
3. Connect the expansion tank to the air separator only if the separator is on the suction side of the circulator. Always install the system fill connection at the same point as the expansion tank connection to the system.
4. Most piping drawings in this manual show diaphragm expansion tanks. See Figure 4 for piping from air separator to expansion tank and make-up water line using a closed-type expansion tank.
5. Most chilled water systems are piped using a closed-type tank, as shown in Figure 10, page 18.

### Diaphragm (or bladder) expansion tank

1. (Figure 4) Always install an automatic air vent on top of the air separator to remove residual air from the system.

### Closed-type expansion tank

1. See Figure 4, Alternate, for piping connections when using a closed-type expansion tank.
2. Pitch any horizontal piping up towards tank 1 inch per 5 feet of piping. Connect to tank with at least  $\frac{3}{4}$ " piping to allow room for air to rise.

#### CAUTION

DO NOT install automatic air vents on closed-type expansion tank systems. Air must remain in the system and return to the tank to provide its air cushion. An automatic air vent would cause air to leave the system, resulting in water-logging the expansion tank.

Figure 4 Expansion tank piping

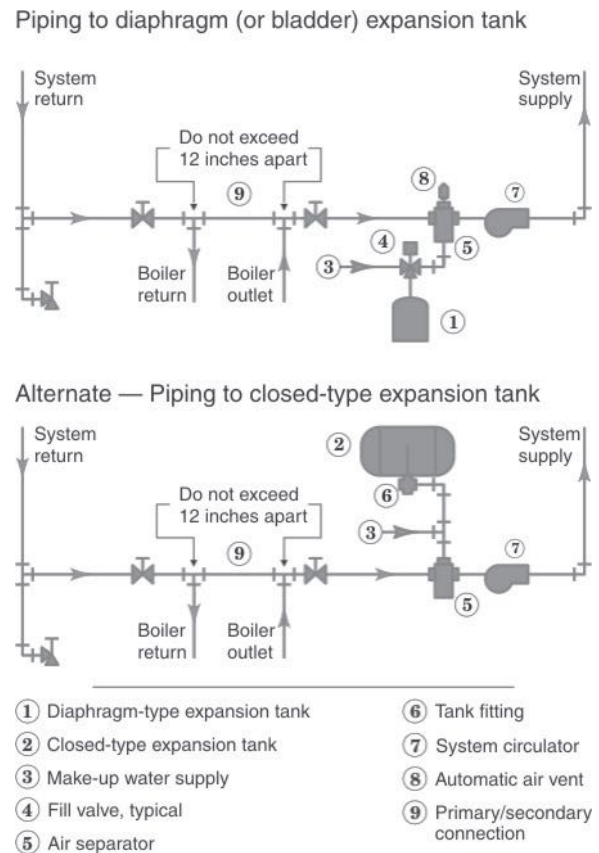

### Circulators

The boiler circulator (Taco 007 for Ultra-80 and -105; Taco 0011 for Ultra-155, -230, and -310) is shipped loose. Locate it either in the return or supply piping, as shown in the appropriate piping diagram in this manual.

#### WARNING

DO NOT use the boiler circulator in any location other than the ones shown in this manual. The boiler circulator is selected to ensure adequate flow through the Ultra boiler. Failure to comply could result in unreliable performance and nuisance shutdowns from insufficient flow.

### Sizing space heat system piping

1. See Figures 7 through 10, pages 15 – 18, for recommended piping. In all diagrams, the space heating system is isolated from the boiler loop by the primary/secondary connection.
2. Size the piping and components in the space heating system using recognized design methods.

# Install water piping *(continued)*

### Sizing DHW system piping

**NOTICE** When using the boiler for dedicated DHW applications, use the circulator supplied with the boiler (007 for Ultra-80/105; 0011 for Ultra-155/230/310) to circulate to the water heater except where higher flow rates may be required for the heater used. Use the following method to select a circulator for the water heater on combined space heating/DHW systems.

- Figure 5 shows recommended DHW piping, as shown in Figures 7 through 10, pages 15 – 18. All show direct connection of the DHW piping to the boiler because the boiler circulator shuts down during DHW operation.
- Figure 6 shows the pump curves for suggested DHW

circulators (Taco 007, 0011, 0012, 0013, 0014, B&G PL-36 or equivalent). Use these curves along with boiler pressure drop data from Table 2 to size the DHW piping and circulator. Or you can use Table 2 for a quick-selection method.

- Table 2 uses the available head from the circulators listed to help you select the right circulator.
  - See Figure 5.
  - H1 is the head loss across the boiler.
  - H2 is the head loss across the DHW piping.
  - H3: Table 2 subtracts H1 and H2 from the available head of the circulator. This gives the maximum value for H3, head loss across the water heater.
- Procedure to select a circulator using Table 2:
  - Step 1: From the water heater manufacturer's data, find:
    - Required boiler water flow rate, GPM, at 180°F.
    - Pressure drop across the water heater at this flow rate, in feet water column.
  - Step 2: Find your boiler model in Table 2. Select a flow rate in column 1 just larger than the required flow rate from step 1.
  - Step 3: The value in column H3 must be larger than the water heater pressure drop from step 1.

**Figure 5** DHW piping (see Table 2 for approximate head losses)

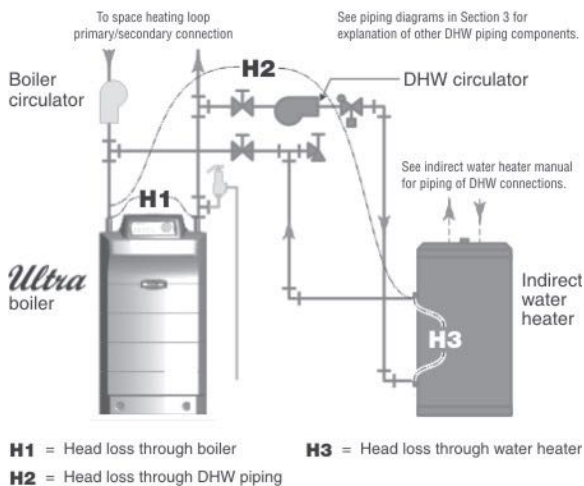

**Table 2** Pipe sizing and head losses for DHW applications (H1=boiler head loss; H2=piping head loss; H3=maximum allowable head loss through water heater based on available head of circulator chosen; i.e., Taco 007, 0011, 0012, 0013 or 0014, or Bell & Gossett PL-36)

Flow rate	Temp rise	Pipe size	H1	H2	H3		
GPM	°F	Inches	Feet w.c.	Feet w.c.	Available head (feet water column) to overcome head loss through water heater		
<b>Ultra-80</b>					<b>Circulator model:</b>		
					<b>007</b>	<b>0012</b>	<b>0011</b>
3.5 (min)	41	1	1.4	0.8	7.9	11.4	25.9
6.7	21	1¼	6.0	1.2	2.0	6.2	18.6
10	14	1¼	14.6	2.5	Not rec.	Not rec.	5.5
<b>Ultra-105</b>					<b>Circulator model:</b>		
					<b>007</b>	<b>0012</b>	<b>0011</b>
4.5 (min)	42	1	3.1	1.2	5.6	9.3	23.1
8.2	23	1¼	9.4	1.8	Not rec.	2.0	13.2
11	17	1¼	16.2	2.9	Not rec.	Not rec.	2.5
<b>Ultra-155</b>					<b>Circulator model:</b>		
					<b>0012</b>	<b>0014</b>	<b>0011</b>
7.0 (min)	40	1	3.6	2.7	7.0	12.2	19.1
10.0	28	1¼	7.7	2.5	2.0	6.8	13.2
13	21	1¼	13.3	3.9	Not rec.	Not rec.	2.2
<b>Ultra-230</b>					<b>Circulator model:</b>		
					<b>0012</b>	<b>0014</b>	<b>0011</b>
10 (min)	41	1	5.9	2.5	2.0	6.1	11.7
11.5	36	1¼	7.5	3.2	2.0	5.6	10.4
14	30	1¼	10.8	4.5	Not rec.	Not rec.	3.0
<b>Ultra-310</b>					<b>Circulator model:</b>		
					<b>0011</b>	<b>0013</b>	<b>PL-36</b>
14.5 (min)	40	1½	4.6	2.1	11.0	16.7	19.9
18	32	1½	6.5	2.9	4.1	10.9	14.4
21.5	27	1½	9.2	4.4	Not rec.	3.5	7.1

**Figure 6** Pump curves for typical circulators suggested for DHW loop

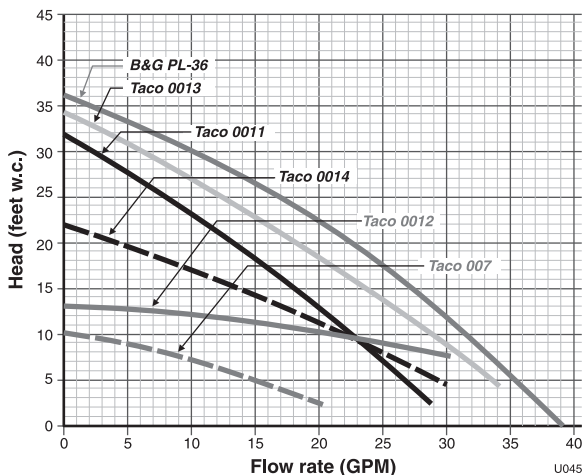

## Install water piping *(continued)*

### Zoning with zone valves

1. Connect boiler to system as shown in Figure 7 when zone valve zoning. The primary/secondary piping shown ensures the boiler loop will have sufficient flow. It also avoids applying the high head of the boiler circulator to the zone valves.
2. When using a closed-type expansion tank, connect the expansion tank and make-up water piping as shown in Figure 4, page 13.
3. Connect DHW (domestic hot water) piping to indirect storage water heater as shown.

**NOTICE**

The *Ultra PhD* Control Module turns off space heating during DHW heating. The boiler circulator will turn off, preventing hot water from circulating to the system. The flow/check valve shown on the boiler outlet piping prevents gravity circulation in the boiler loop during DHW heating.

4. Controlling the system circulator
  - a. To cycle the system circulator from the *Ultra PhD* control module, add a circulator relay wired to the boiler circulator terminals as shown in the *Ultra Control Supplement*.

**NOTE 1:** To ensure adequate flow rate through the boiler, use the following pipe size on all boiler loop piping (connecting boiler to and from the primary/secondary connection, item 21):  
 Ultra-80 or Ultra-105 – 1" or larger.  
 Ultra-155 or -230 – 1¼" or larger.  
 Ultra-310 – 1½" or larger.

**CAUTION**

Use at least the minimum piping size above and pipe the boiler using only primary/secondary piping as shown. Failure to follow these guidelines could result in system problems.

**Figure 7** Zone valve zoning plus optional DHW piping

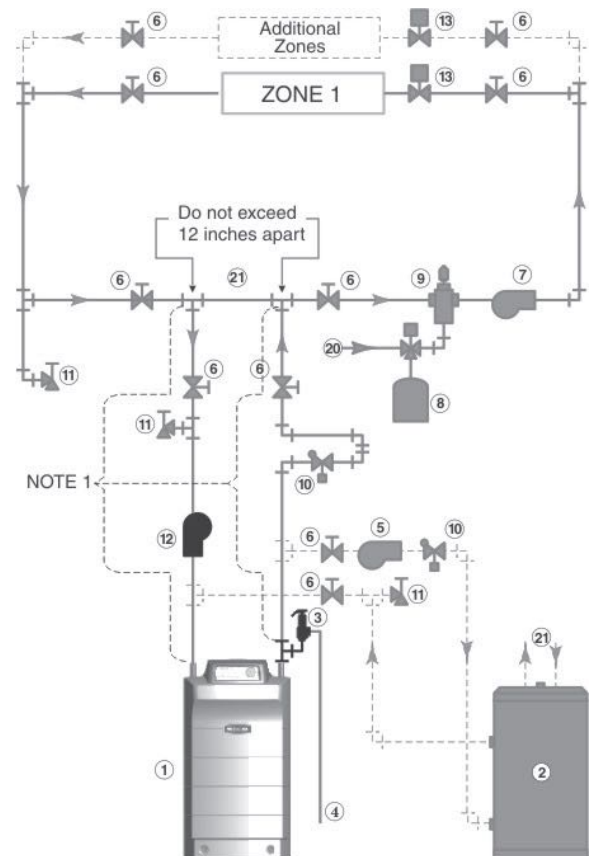

### Legend Figure 7

- |  |   |
|--|---|
| 1 Ultra boiler   | 10 Flow/check valves (with weighted seats to prevent gravity circulation) |
| 2 Indirect water heater (DHW), if used   | 11 Purge/drain valves   |
| 3 Boiler relief valve (see page 12 for piping details)   | 12 Boiler circulator  |
| 4 Relief valve discharge piping (see page 12 for details)  | 13 Zone valves, typical   |
| 5 DHW circulator (see page 14 for suggested sizing)  | 20 Make-up water supply   |
| 6 Isolation valves   | 21 Primary/secondary connection   |
| 7 System circulator  |   |
| 8 Diaphragm (or bladder) type expansion tank (see page 12 for piping of closed-type expansion tank, if used) | ■ — Supplied with boiler  |
| 9 Air separator [with automatic air vent only on systems using diaphragm (or bladder) type expansion tank]   | ■ — By others (not included with boiler)                                  |

### Install water piping *(continued)*

#### Zoning with circulators

1. Connect boiler to system as shown in Figure 8 when circulator zoning. The boiler circulator cannot be used for a zone. It must supply only the boiler loop.
2. Install a separate circulator for each zone.
3. When using a closed-type expansion tank, connect the expansion tank and make-up water piping as shown in Figure 4, page 13.
4. Connect DHW (domestic hot water) piping to indirect storage water heater as shown.

**NOTICE**

The *Ultra PhD* Control Module turns off space heating during DHW heating. The boiler circulator will turn off, preventing hot water from circulating to the system. The flow/check valve shown on the boiler outlet piping prevents gravity circulation in the boiler loop during DHW heating.

**NOTE 1:** To ensure adequate flow rate through the boiler, use the following pipe size on all boiler loop piping (connecting boiler to and from the primary/secondary connection, item 21):  
 Ultra-80 or Ultra-105 – 1" or larger.  
 Ultra-155 or -230 – 1¼" or larger.  
 Ultra-310 – 1½" or larger.

**CAUTION**

Use at least the minimum piping size above and pipe the boiler using only primary/secondary piping as shown. Failure to follow these guidelines could result in system problems.

**Figure 8** Circulator zoning plus optional DHW piping

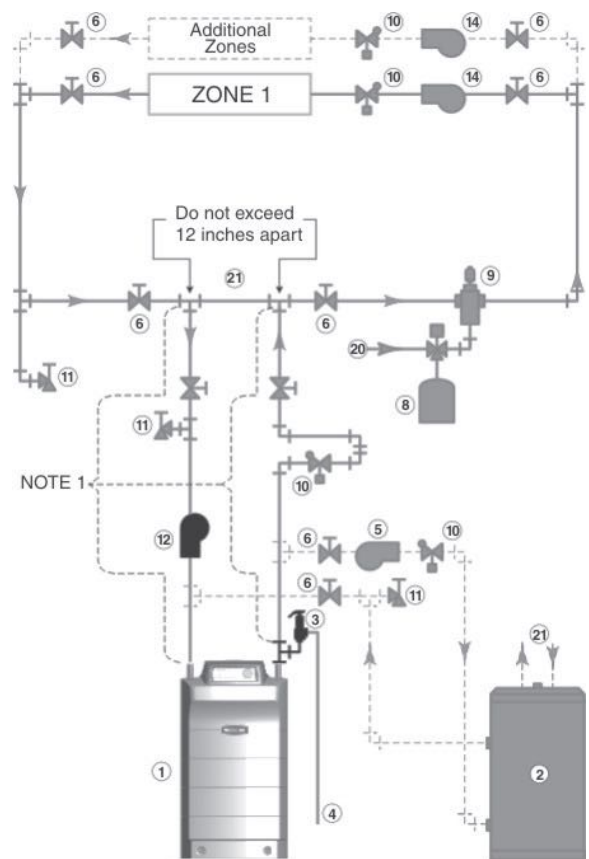

**Legend** Figure 8

- |   |   |
|---|---|
| <ul style="list-style-type: none"> <li>1 Ultra boiler</li> <li>2 Indirect water heater (DHW), if used</li> <li>3 Boiler relief valve (see page 12 for piping details)</li> <li>4 Relief valve discharge piping (see page 12 for details)</li> <li>5 DHW circulator (see page 14 for suggested sizing)</li> <li>6 Isolation valves</li> <li>7 System circulator</li> <li>8 Diaphragm (or bladder) type expansion tank (see page 12 for piping of closed-type expansion tank, if used)</li> <li>9 Air separator [with automatic air vent only on systems using diaphragm (or bladder) type expansion tank]</li> </ul> | <ul style="list-style-type: none"> <li>10 Flow/check valves (with weighted seats to prevent gravity circulation)</li> <li>11 Purge/drain valves</li> <li>12 Boiler circulator</li> <li>14 Zone circulators, typical</li> <li>20 Make-up water supply</li> <li>21 Primary/secondary connection</li> </ul> <p> <span style="display: inline-block; width: 10px; height: 10px; background-color: black; margin-right: 5px;"></span> — Supplied with boiler<br/> <span style="display: inline-block; width: 10px; height: 10px; background-color: gray; margin-right: 5px;"></span> — By others (not included with boiler)         </p> |
|---|---|



## Install water piping *(continued)*

### Radiant heating applications

- The Ultra boiler is ideal for use in radiant heating. The Ultra boiler's unique heat exchanger design allows it to work well even in condensing mode. So there is no need to regulate boiler return water temperature in radiant heating applications.
- Connect boiler to system as shown in Figure 9 for typical radiant heating applications. The primary/secondary piping shown ensures the boiler loop will have sufficient flow. Size the system piping and circulator to provide the flow and pressure drop needed for the radiant system.
- Add the high limit control (Figure 9, item 22) to ensure supply water temperature will not exceed the maximum allowable for the radiant system. Wire this limit control between low voltage terminal strip terminals 6 and 7.
- When using a closed-type expansion tank, connect the expansion tank and make-up water piping as shown in Figure 4, page 13.
- Connect DHW (domestic hot water) piping to indirect storage water heater as shown.

**NOTICE**

The *Ultra PhD* Control Module turns off space heating during DHW heating. The boiler circulator will turn off, preventing hot water from circulating to the system. The flow/check valve shown on the boiler outlet piping prevents gravity circulation in the boiler loop during DHW heating.

- Controlling the system circulator
  - To cycle the system circulator from the Ultra PhD control module, add a circulator relay wired to the boiler circulator terminals as shown in the Ultra Control Supplement
- Setting boiler outlet water target temperature.
  - Follow procedure in Ultra Control Supplement to set space heating target temperature to the desired supply temperature for the system. For outdoor reset operation, install and connect the outdoor temperature sensor supplied with the boiler.

**NOTE 1:** To ensure adequate flow rate through the boiler, use the following pipe size on all boiler loop piping (connecting boiler to and from the primary/secondary connection, item 21):

Ultra-80 or Ultra-105 – 1" or larger.

Ultra-155 or -230 – 1¼" or larger.

Ultra-310 – 1½" or larger.

**Figure 9** Typical radiant heating system piping plus optional DHW

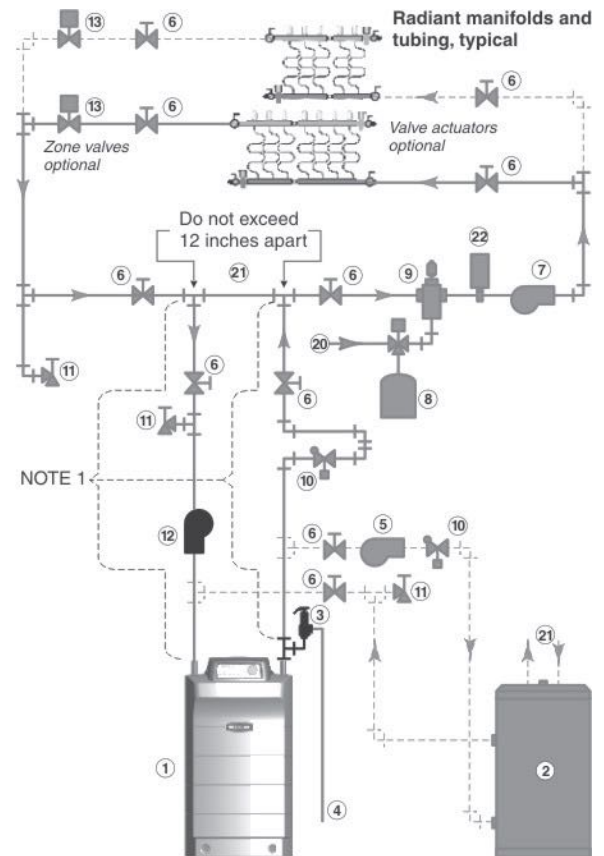
**CAUTION**

Use at least the minimum piping size at left and pipe the boiler using only primary/secondary piping as shown. Failure to follow these guidelines could result in system problems.

### Legend Figure 9

- |  |  |
|--|--|
| 1 Ultra boiler   | 10 Flow/check valves (with weighted seats to prevent gravity circulation)                  |
| 2 Indirect water heater (DHW), if used   | 11 Purge/drain valves  |
| 3 Boiler relief valve (see page 12 for piping details)   | 12 Boiler circulator   |
| 4 Relief valve discharge piping (see page 12 for details)  | 13 Zone valves, when used (zoning may also be done using manifold-mounted valve actuators) |
| 5 DHW circulator (see page 14 for suggested sizing)  | 20 Make-up water supply  |
| 6 Isolation valves   | 21 Primary/secondary connection  |
| 7 System circulator  | 22 High limit temperature control, set to protect radiant tubing                           |
| 8 Diaphragm (or bladder) type expansion tank (see page 12 for piping of closed-type expansion tank, if used) | ■ — Supplied with boiler   |
| 9 Air separator [with automatic air vent only on systems using diaphragm (or bladder) type expansion tank]   | ■ — By others (not included with boiler)   |

### Install water piping *(continued)*

#### Chilled water systems

1. Install boiler so that chilled medium is piped in parallel with the heating boiler. Use appropriate valves to prevent chilled medium from entering boiler.
2. The space heating system may be zoned with circulators if a separate circulator is supplied for the chilled water loop.
3. If boiler is connected to heating coils located in air handling units where they can be exposed to refrigerated air, use flow control valves or other automatic means to prevent gravity circulation during cooling cycle.

**CAUTION** Follow these piping guidelines below to ensure chilled water does not enter the boiler loop.

**WARNING** Chilled medium, if used, is piped in parallel with heating boiler as shown in Figure 10. Use appropriate valves to prevent chilled medium from entering boiler.

If boiler is connected to heating coils located in air handling units where they can be exposed to refrigerated air, use flow control valves or other automatic means to prevent gravity circulation during cooling cycle.

**NOTE 1:** To ensure adequate flow rate through the boiler, use the following pipe size on all boiler loop piping (connecting boiler to and from the primary/secondary connection, item 21):  
 Ultra-80 or Ultra-105 – 1" or larger.  
 Ultra-155 or -230 – 1¼" or larger.  
 Ultra-310 – 1½" or larger.

**CAUTION** Use at least the minimum piping size above and pipe the boiler using only primary/secondary piping as shown. Failure to follow these guidelines could result in system problems.

**Figure 10** Chilled water system plus optional DHW piping

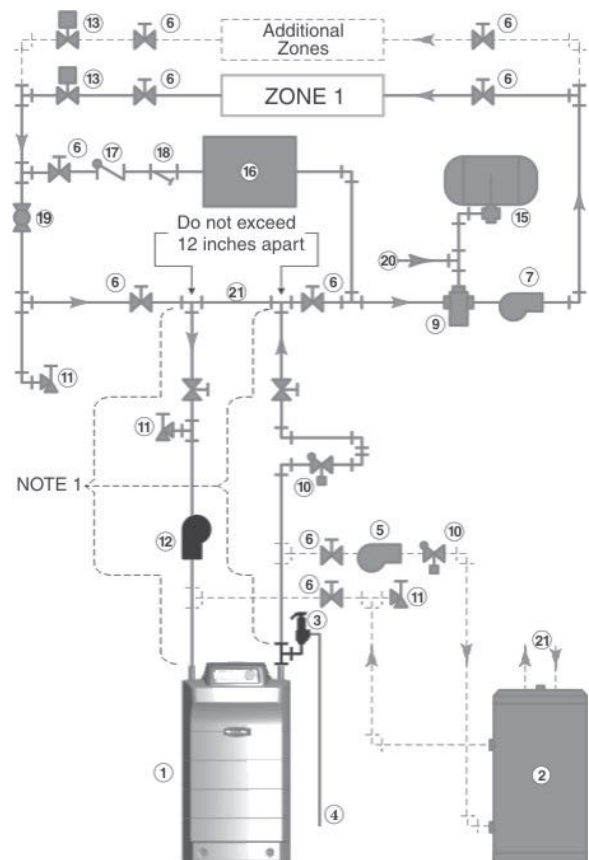

#### Legend Figure 10

- |   |  |
|---|--|
| 1 Ultra boiler  | 12 Boiler circulator                     |
| 2 Indirect water heater (DHW), if used  | 13 Zone valves, typical                  |
| 3 Boiler relief valve (see page 12 for piping details)                                    | 15 Closed-type expansion tank            |
| 4 Relief valve discharge piping (see page 12 for details)                                 | 16 Water chiller                         |
| 5 DHW circulator (see page 14 for suggested sizing)                                       | 17 Check valve                           |
| 6 Isolation valves  | 18 Strainer                              |
| 7 System circulator   | 19 Balancing valve                       |
| 9 Air separator (DO NOT use automatic air vents on systems fitted with closed-type tanks) | 20 Make-up water supply                  |
| 10 Flow/check valves (with weighted seats to prevent gravity circulation)                 | 21 Primary/secondary connection          |
| 11 Purge/drain valves   | ■ — Supplied with boiler                 |
|   | ■ — By others (not included with boiler) |

## Venting, combustion air & condensate line

### Install vent and combustion air piping

#### DANGER

Ultra Boiler must be vented and supplied with combustion and ventilation air as described in Weil-McLain Ultra Boiler Vent Supplement (included in envelope assembly). Ensure the vent and air piping and the combustion air supply comply with these instructions regarding vent system, air system and combustion air quality. See also Section 1 of this manual.

Inspect finished vent and air piping thoroughly to ensure all are airtight and comply with the instructions provided and with all requirements of applicable codes.

Failure to provide a properly-installed vent and air system will cause severe personal injury or death.

### Prepare condensate fittings

1. Remove PVC fittings and gasket from the accessories bag.
2. Deburr and chamfer outside and inside of ½" x 1¼" PVC nipple to ensure even cement distribution when joining.
3. Clean nipple ends and all fittings. Dry thoroughly.
4. For each joint in the condensate line, apply the following. Assemble parts ONLY in the order given.
  - a. Apply primer liberally to both joint surfaces — pipe end and fitting socket.
  - b. While primer is still damp, lightly apply approved cement to both surfaces in a uniform coating.
5. See Figure 11.
6. Assemble the ½" PVC nipple to the PVC reducing elbow as shown.
7. Allow joint to dry completely. Then slide gasket over nipple as shown.
8. Slide nipple through jacket condensate line hole to position as shown in Figure 13, page 20.
9. Cement the ½" tee to the protruding ½" nipple. Be sure both nipple and reducing elbow finish upright. **IMPORTANT:** Firmly press the reducing elbow and the tee together while the cement sets to ensure the gasket is securely compressed. The gasket ensures the jacket enclosure is airtight at this location.

Figure 11 Condensate trap assembly

#### PVC reducing elbow

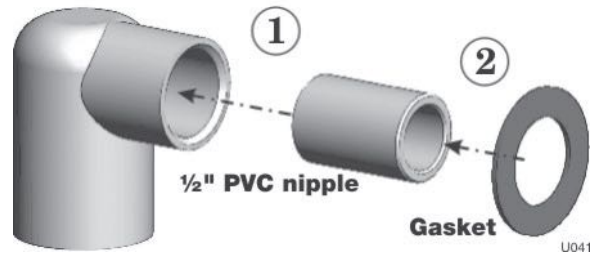

## Venting, combustion air & condensate line *(continued)*

### Connect condensate drain

1. Remove condensate trap line from bag. Prepare and install per page 19. Secure to jacket by attaching PVC tee as shown in Figure 12, 13 or 14. Secure with hose clamps.
2. Slide trap line onto flue outlet condensate connection and PVC reducing elbow as shown in Figure 12, 13 or 14. Secure with hose clamps.
3. Connect condensate drain tubing to the ½" PVC tee and run to floor drain or condensate pump. Use ½" PVC or CPVC pipe; or 5/8" I.D. tubing.

**NOTICE** Use materials approved by the authority having jurisdiction. In the absence of other authority, PVC and CPVC pipe must comply with ASTM D1785, F441 or D2665. Cement and primer must comply with ASTM D2564 or F493. For Canada, use CSA or ULC certified PVC or CPVC pipe, fittings and cement.

4. Leave the top of the ½" tee OPEN. This is needed as a vacuum break.
5. When installing a condensate pump, select one approved for use with condensing boilers and furnaces. The pump should have an overflow switch to prevent property damage from condensate spillage.
6. Condensate from the Ultra boiler will be slightly acidic (typically with a pH from 3.2 to 4.5). Install a neutralizing filter if required by local codes.

**CAUTION** The condensate line must remain unobstructed, allowing free flow of condensate. If condensate is allowed to freeze in the line or if the line is obstructed in any other manor, condensate can exit from the boiler tee, resulting in potential water damage to property.

**Figure 12** Condensate drain — Ultra-80 & -105

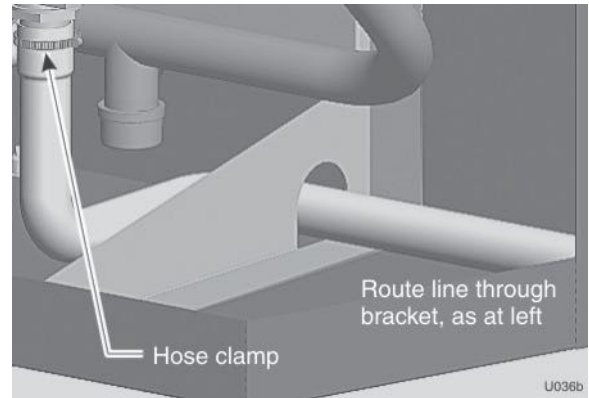

**Figure 13** Condensate drain — Ultra-155 & -230 (PVC tee installation shown applies to all models))

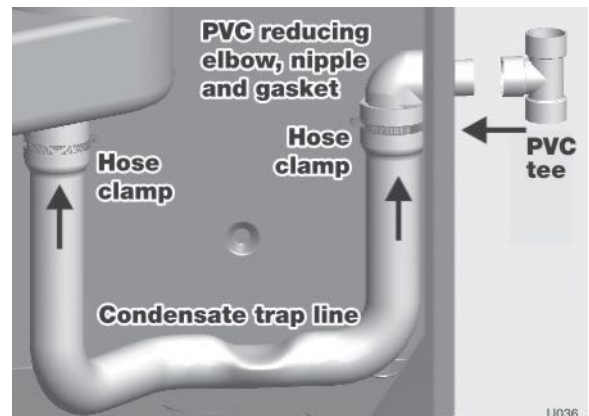

**Figure 14** Condensate drain — Ultra-310

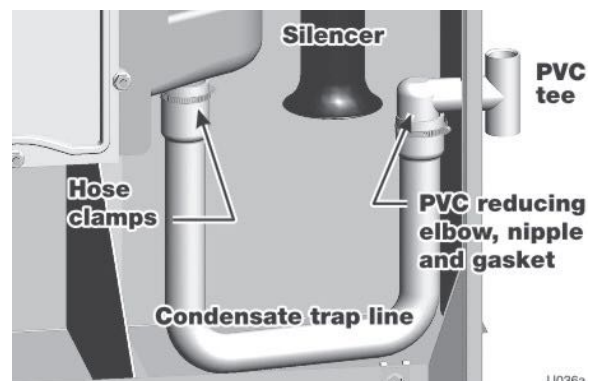

## Gas piping

### Connecting gas supply piping

1. Remove jacket front panel and refer to Figure 15 to pipe gas to boiler.
  - a. Install ground joint union for servicing, when required.
  - b. Install manual shutoff valve in gas supply piping outside boiler jacket when required by local codes or utility requirements.
  - c. In Canada — When using manual main shutoff valve, it must be identified by the installer.
2. Wall-mounted boilers
  - a. Refer to separate Ultra Boiler Wall-mounting instructions.
  - b. Gas connection may enter from the bottom of boiler as explained in the Wall-mounting instructions.
3. Support piping with hangers, not by boiler or its accessories.
4. Purge all air from gas supply piping.
5. Before placing boiler in operation, check boiler and its gas connection for leaks.
  - a. Close manual main shutoff valve during any pressure testing at less than 13" w.c.
  - b. Disconnect boiler and gas valve from gas supply piping during any pressure testing greater than 13" w.c.

**WARNING** Do not check for gas leaks with an open flame — use bubble test. Failure to use bubble test or check for gas leaks can cause severe personal injury, death or substantial property damage.

6. Use pipe dope compatible with propane gases. Apply sparingly only to male threads of pipe joints so that pipe dope does not block gas flow.

**WARNING** Failure to apply pipe dope as detailed above can result in severe personal injury, death or substantial property damage.

**WARNING** DO NOT adjust or attempt to measure gas valve outlet pressure. The gas valve is factory-set for the correct outlet pressure. This setting is suitable for natural gas and propane, requiring no field adjustment. Attempting to alter or measure the gas valve outlet pressure could result in damage to the valve, causing potential severe personal injury, death or substantial property damage.

**WARNING** Ultra boilers are shipped ready to fire natural gas ONLY. (Exception: Ultra-80LP is propane-ready.) You must install the propane orifice if the boiler will be connected to propane. See page 9. Failure to comply could result in severe personal injury, death or substantial property damage.

**Figure 15** Connect gas supply piping

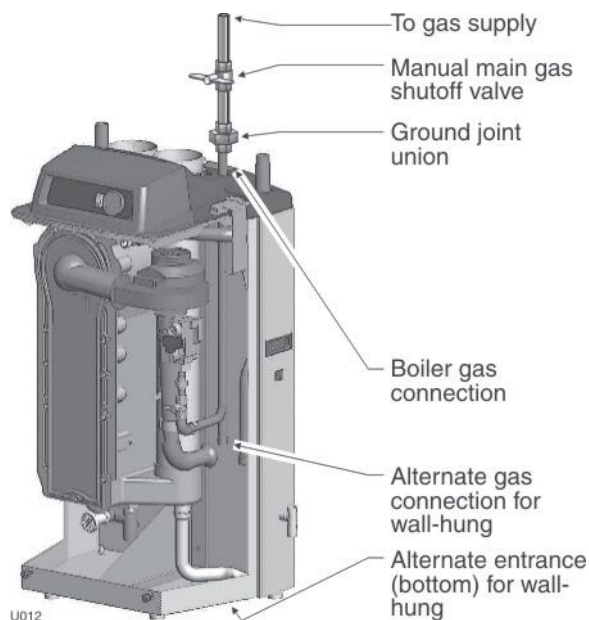

**WARNING** Use two wrenches when tightening gas piping at boiler, using one wrench to prevent the boiler gas line connection from turning. Failure to support the boiler gas connection pipe to prevent it from turning could damage gas line components.

## Gas piping *(continued)*

### Natural Gas:

#### Pipe sizing for natural gas

1. Refer to Table 4 for pipe length and diameter. Base on rated boiler input (divide by 1,000 to obtain cubic feet per hour).
  - a. Table 4 is only for natural gas with specific gravity 0.60, with a pressure drop through the gas piping of 0.30" w.c.
  - b. For additional gas pipe sizing information, refer to ANSI Z223.1 (or B149.1 or B149.2 for Canadian installations).

#### Natural gas supply pressure requirements

1. Pressure required at gas valve inlet pressure port:
  - Maximum: 13" w.c. with no flow (lockup) or with boiler on
  - Minimum: 5" w.c. with gas flowing (verify during boiler startup, while boiler is at high fire)
2. Install 100% lockup gas pressure regulator in supply line if inlet pressure can exceed 13" w.c. at any time. Adjust lockup regulator for 13" w.c. maximum.

### Propane Gas:

#### WARNING

Ultra boilers are shipped ready to fire natural gas ONLY (exception: Ultra-80-LP is propane-ready). You must install the propane orifice if the boiler will be connected to propane. See page 9. Failure to comply could result in severe personal injury, death or substantial property damage.

#### Pipe sizing for natural gas

1. Contact gas supplier to size pipes, tanks and 100% lockup gas pressure regulator.

#### Propane supply pressure requirements

1. Adjust propane supply regulator provided by gas supplier for 13" w.c. maximum pressure.
2. Pressure required at gas valve inlet pressure port:
  - Maximum: 13" w.c. with no flow (lockup) or with boiler on
  - Minimum: 4" w.c. with gas flowing (verify during boiler startup, while boiler is at high fire)

**Table 4** Pipe capacity for 0.60 specific gravity natural gas

Gas pipe length (feet)	Capacity of pipe for pipe size of: (Capacity in cubic feet gas per hour)				
	1/2"	3/4"	1"	1 1/4"	1 1/2"
10	132	278	520	1050	1600
20	92	190	350	730	1100
30	73	152	285	590	860
40	63	130	245	500	760
50	56	115	215	440	670
75	45	93	175	360	545
100	38	79	150	305	460
150	31	64	120	250	380

## Startup

### Check/control water chemistry

**WARNING** Do not use petroleum-based cleaning or sealing compounds in boiler system. Damage to elastomer seals and gaskets in system could occur, resulting in substantial property damage.

**WARNING** Before filling the boiler and system with water, verify the following. Failure to comply could result in boiler failure or unreliable operation.

#### Water pH between 7.0 and 8.5

1. Maintain boiler water pH between 7.0 and 8.5. Check with litmus paper or have chemically analyzed by water treatment company.
2. If pH differs from above, consult local water treatment company for treatment needed.

#### Hardness less than 7 grains

1. Consult local water treatment companies for unusually hard water areas (above 7 grains hardness).

#### Chlorine concentration less than 200 ppm

1. Filling with chlorinated fresh water should be acceptable since drinking water chlorine levels are typically less than 5 ppm.
2. Do not use the boiler to directly heat swimming pool or spa water.
3. Do not fill boiler or operate with water containing chlorine in excess of 200 ppm.

#### Clean system to remove sediment

1. You must thoroughly flush the system (without boiler connected) to remove sediment. The high-efficiency heat exchanger can be damaged by buildup or corrosion due to sediment.
2. For zoned systems, flush each zone separately through a purge valve. (If purge valves and isolation valves are not already installed, install them to properly clean the system.)
3. Flush system until water runs clean and you are sure piping is free of sediment.

#### Test/replace freeze protection fluid

1. For systems using freeze protection fluids, follow guidelines in Ultra Boiler Freeze Protection Supplement.

### Freeze protection (when used)

**WARNING** NEVER use automotive or standard glycol antifreeze, even glycol made for hydronic systems. Use only freeze-protection fluids recommended in the Ultra Boiler Freeze Protection Supplement. Follow all guidelines in the Freeze Protection Supplement, and thoroughly clean and flush any replacement boiler system that has used glycol before installing the new Ultra boiler.

1. Determine freeze protection fluid quantity using total system water content, following fluid manufacturers's instructions. Boiler water content is listed on page 43. Remember to include expansion tank water content.

2. Local codes may require back flow preventer or actual disconnect from city water supply.
3. When using freeze protection fluid with automatic fill, install a water meter to monitor water make-up. Freeze protection fluid may leak before the water begins to leak, causing concentration to drop, reducing the freeze protection level.

### Fill and test water system

1. Fill system only after ensuring the water meets the requirements of this manual.
2. Close manual and automatic air vents and boiler drain valve.
3. Fill to correct system pressure. Correct pressure will vary with each application.
  - a. Typical cold water fill pressure for a residential system is 12 psi.
  - b. Pressure will rise when boiler is turned on and system water temperature increases. Operating pressure must never exceed 25 psig.
4. At initial fill and during boiler startup and testing, check system thoroughly for any leaks. Repair all leaks before proceeding further.

**WARNING** Eliminate all system leaks. Continual fresh make-up water will reduce boiler life. Minerals can build up in sections, reducing heat transfer, overheating heat exchanger, and causing heat exchanger failure.

5. The system may have residual substances that could affect water chemistry. After the system has been filled and leak tested, verify water pH and chlorine concentrations are acceptable.

### Purge air from water system

1. Purge air from system:
  - a. Connect a hose to the purge valve (see purge/drain valves, item 11, in piping diagrams on pages 15 through 18. Route hose to an area where water can drain and be seen.
  - b. Close the boiler or system isolation valve between the purge valve and fill connection to the system.
  - c. Close zone isolation valves.
  - d. Open quick-fill valve on cold water make-up line.
  - e. Open purge valve.
  - f. One zone at a time, open the isolation valves. Allow water to run through the zone, pushing out the air. Run until no noticeable air flow is present. Close the zone isolation valves and proceed with the next zone. Follow this procedure until all zones are purged.
  - g. Close the quick-fill water valve and purge valve and remove the hose. Open all isolation valves. Watch that system pressure rises to correct cold-fill pressure.
  - h. After the system has operated for a while, eliminate any residual air by using the manual air vents located throughout the system.
  - i. If purge valves are not installed in system, open manual air vents in system one at a time, beginning with lowest floor. Close vent when water squirts out. Repeat with remaining vents.
2. Open automatic air vent (diaphragm-type or bladder-type expansion tank systems only) one turn.
3. Open other vents:
  - a. Starting on the lowest floor, open air vents one at a time until water squirts out.
  - b. Repeat with remaining vents.
4. Refill to correct pressure.

## Startup *(continued)*

### Check for gas leaks

**WARNING** Before starting the boiler, and during initial operation, smell near the floor and around the boiler for gas odorant or any unusual odor. Remove boiler front door and smell interior of boiler enclosure. Do not proceed with startup if there is any indication of a gas leak. Repair any leak at once.

**WARNING** DO NOT adjust or attempt to measure gas valve outlet pressure. The gas valve is factory-set for the correct outlet pressure. This setting is suitable for natural gas and propane, requiring no field adjustment. Attempting to alter or measure the gas valve outlet pressure could result in damage to the valve, causing potential severe personal injury, death or substantial property damage.

**WARNING** Propane boilers only — Your propane supplier mixes an odorant with the propane to make its presence detectable. In some instances, the odorant can fade, and the gas may no longer have an odor. Before startup (and periodically thereafter), have the propane supplier verify the correct odorant level in the gas.

### Check thermostat circuit(s)

1. Disconnect the two external wires connected to the boiler thermostat terminals (low voltage terminal strip terminals 5 and 6).
2. Connect a voltmeter across these two incoming wires. Close each thermostat, zone valve and relay in the external circuit one at a time and check the voltmeter reading across the incoming wires.
3. There should NEVER be a voltage reading.
4. If a voltage does occur under any condition, check and correct the external wiring. (This is a common problem when using 3-wire zone valves.)
5. Once the external thermostat circuit wiring is checked and corrected if necessary, reconnect the external thermostat circuit wires to boiler low voltage terminal strip terminals 5 and 6. Allow the boiler to cycle.

### Inspect/fill condensate system

#### Inspect/check condensate lines and fittings

1. Inspect the condensate drain line, condensate PVC fittings and condensate trap. (See page 20 for component locations.)
2. Pour water into the top of the boiler's 1/2" PVC condensate tee and check for any leaks in the condensate drain line or fittings. Repair any leaks.

#### Fill condensate trap with water

1. Loosen the hose clamp securing the right end of the condensate trap to the PVC reducing elbow (see page 20).
2. Slide the trap hose end off of the elbow.
3. Fill the trap with fresh water to within a inch of the end of the hose.
4. Replace trap hose on PVC reducing elbow and tighten the hose clamp.

**WARNING** The condensate trap (page 3, item 23a) must be filled with water during all times of boiler operation to avoid flue gas emission from the condensate drain line. Failure to fill the trap could result in severe personal injury or death.

### Final checks before starting boiler

- Read the Ultra Control Supplement to familiarize yourself with Ultra PhD control module operation. Read Operating Instructions in Control Supplement for proper steps to start boiler.
- Verify the boiler and system are full of water and all system components are correctly set for operation.
- Verify the preparation procedures of section 6, pages 23 and 24 have been completed.
- Fill vent condensate trap with water (by removing hose clamp and hose at PVC reducing elbow). Replace hose on PVC reducing elbow and tighten clamp.
- Verify electrical connections are correct and securely attached.
- Inspect vent piping and air piping for signs of deterioration from corrosion, physical damage or sagging. Verify air piping and vent piping are intact and correctly installed per Ultra Boiler Vent Supplement.

### To start the boiler

1. Turn OFF Power switch on Ultra display panel. Turn on power to boiler.
2. Read and follow the Operating Instructions in the Ultra Control Supplement.

### If boiler does not start correctly

1. Check for loose connections, blown fuse or service switch off?
2. Is external limit control (if used) open? Is boiler water temperature above 200 °F?
3. Is thermostat set below room temperature?
4. Is gas turned on at meter or boiler?
5. Is incoming gas pressure less than 4" w.c. for natural gas or 5" w.c. for propane?
6. Are parameters set correctly as instructed in the Ultra Control Supplement?

If none of the above corrects the problem, refer to Troubleshooting in the Ultra Control Supplement.



## Startup *(continued)*

### ☐ Check system and boiler

#### ☐ Check water piping

1. Check system piping for leaks. If found, shut down boiler and repair immediately. (See WARNINGS on page 23 regarding failure to repair leaks.)
2. Vent any remaining air from system using manual vents. Air in the system will interfere with circulation and cause heat distribution problems and noise.

#### ☐ Check vent piping and air piping

1. Check for gas-tight seal at every connection and seam of air piping and vent piping.

**WARNING** Venting system must be sealed gas-tight to prevent flue gas spillage and carbon monoxide emissions which will result in severe personal injury or death.

#### ☐ Check gas piping

1. Check around the boiler for gas odor following the procedure of page 21 of this manual.

**WARNING** If you discover evidence of any gas leak, shut down the boiler at once. Find the leak source with bubble test and repair immediately. Do not start boiler again until corrected. Failure to comply could result in severe personal injury, death or substantial property damage.

#### ☐ Propane boilers — verify conversion

1. Verify propane orifice has been installed per Propane Conversion instructions.

**WARNING** DO NOT adjust or attempt to measure gas valve outlet pressure. The gas valve is factory-set for the correct outlet pressure. This setting is suitable for natural gas and propane, requiring no field adjustment. Attempting to alter or measure the gas valve outlet pressure could result in damage to the valve, causing potential severe personal injury, death or substantial property damage.

**WARNING** Ultra boilers are shipped ready to fire natural gas ONLY. Exception: The Ultra-80LP is factory-equipped to fire propane. You must install the propane orifice if the boiler will be connected to propane. See page 9. Failure to comply could result in severe personal injury, death or substantial property damage.

### ☐ Check flame & combustion

1. Press and hold both the Ultra control panel “Mode” and “+” buttons simultaneously until “H” appears.
2. The “H” in the first digit of the display means the boiler will operate at high fire when the blower speed reaches maximum.
3. Look at the flame through the flame inspection window. The high fire flame should be blue and should be stable. The burner surface should be covered with orange dots.
4. Remove the flue temperature sensor from the flue pipe and insert a combustion test probe.
5. Testing is suggested for either CO<sub>2</sub> or O<sub>2</sub> and for CO. The values should be in the range listed in the table below. The CO should not exceed 100 ppm when combustion is correct.

**WARNING** If combustion at either high or low fire is outside the range given below, shut down the boiler and contact your local Weil-McLain representative. Failure to comply could result in severe personal injury, death or substantial property damage.

Natural gas				Propane			
CO <sub>2</sub> min.	CO <sub>2</sub> max.	O <sub>2</sub> min.	O <sub>2</sub> max.	CO <sub>2</sub> min.	CO <sub>2</sub> max.	O <sub>2</sub> min.	O <sub>2</sub> max.
8.0%	10.0%	3.5%	7.0%	9.5%	11.5%	3.1%	5.9%

6. Measure natural gas input:
  - a. Operate boiler 10 minutes.
  - b. Turn off other appliances.
  - c. At natural gas meter, measure time (in seconds) required to use one cubic foot of gas.
  - d. Calculate gas input: 
$$\frac{3600 \times 1000}{\text{number of seconds from step c}} = \text{Btuh}$$
  - e. Btuh calculated should approximate input rating on boiler rating label.
7. Press and hold the Ultra control panel “Mode” and “-” buttons simultaneously until the display shows “L”.
8. The “L” in the first digit means the boiler will operate at low fire when the blower speed reaches minimum.
9. Look at the flame through the flame inspection window. The low fire flame should be stable and evenly distributed over burner surface with a uniform orange color.
10. Repeat the combustion test of steps 4 and 5 above.
11. Press and hold the “+” and “-” buttons to return boiler to automatic firing.
12. Replace flue gas temperature sensor.

**WARNING** You must replace the flue gas temperature sensor to prevent flue gas spillage into the boiler enclosure. Failure to comply could result in severe personal injury, death or substantial property damage.

### ☐ Adjust and test boiler controls

1. Follow instructions in the Ultra Control Supplement to set and verify operation of the boiler controls.

## Check-out/startup verification

- Boiler and heat distribution units filled with water?
  - Water chemistry verified per page 23?
  - Automatic air vents, if used, open one full turn?
  - Air purged from system?
  - Air purged from gas piping? Piping checked for leaks?
  - Propane orifice installed for propane firing and propane conversion label affixed to jacket?
- WARNING** Ultra boilers are shipped ready to fire natural gas ONLY. Exception: The Ultra-80LP is factory-equipped to fire propane. You must install the propane orifice or conversion kit (Ultra-80NG) if the boiler will be connected to propane. See page 9. Failure to comply could result in severe personal injury, death or substantial property damage.
- Thermostat circuit wiring checked to ensure there are no stray voltages per page 24, “Check Thermostat Wires?”
  - Followed Operating Instructions in Ultra Control Supplement?
  - Burner flame and combustion verified per page 25?
  - Verified control operation for space heating and DHW (if used) per Ultra Control Supplement?
  - Tested additional field-installed controls — If boiler has a low water cutoff, additional high limit or other controls, tested for operation as outlined by manufacturer? (Boiler should be operating and should go off when controls are tested. Verify controls cause soft lockout or hard lockout as desired.)
- Set additional field-installed limit control(s) to system temperature requirements? Adjusted balancing valves and controls to provide design temperature to system?
  - For multiple zones, adjusted for correct flow in each zone?
  - Verified thermostat heat anticipator (if available) set properly? Refer to Ultra Control Supplement.
  - Cycled boiler with thermostat (and with DHW aquastat, if installed) — Raised to highest setting and verified boiler goes through normal startup cycle? Lowered to lowest setting and verified boiler goes off?
  - Measured natural gas input? (per page 25)
  - Checked incoming gas pressure by connecting manometer to gas valve ahead of boiler? (Gas pressure must be at least 5 inches w.c. for natural gas, and 4 inches w.c. for propane, with boiler operating at high fire, and no more than 13 inches w.c. with boiler operating or boiler off.)
  - Observed several operating cycles for proper operation.
  - Set room thermostat to desired room temperature (and DHW aquastat, if installed, to desired DHW storage temperature)?
  - Reviewed all instructions shipped with this boiler with owner or maintenance person?
  - Fill in **Installation certificate** on page 27.
  - Return instructions to envelope and give to owner or place inside boiler housing.

## Check-out/startup verification

### Installation certificate

Boiler model _____	Comments: _____
CP number _____	_____
Date installed _____	_____
Measured Btuh input _____ Fuel: <input type="checkbox"/> Natural Gas <input type="checkbox"/> Propane	_____
<input type="checkbox"/> Installation instructions have been followed.	_____
<input type="checkbox"/> Check out sequence has been performed.	_____
<input type="checkbox"/> Above information is certified to be correct.	_____
<input type="checkbox"/> Information received and left with owner/maintenance person	_____
Installer _____ (company) _____ (phone)	
_____ (address)	
_____ (address)	_____
	(installer's signature)

## Annual startup and general maintenance

**Table 5** Service and maintenance schedules

<b>Service technician</b> (see following pages for instructions)		<b>Owner maintenance</b> (see Ultra User's Information Manual for instructions)	
<b>ANNUAL START-UP</b>	<b>General:</b>	<b>Daily</b>	<ul style="list-style-type: none"> <li>• Check boiler area</li> <li>• Check air openings</li> <li>• Check pressure/temperature gauge</li> <li>• Verify boiler front door is securely in place</li> </ul>
	<ul style="list-style-type: none"> <li>• Reported problems</li> <li>• Inspect interior; clean and vacuum if necessary; WARNING — no solvents</li> <li>• Clean condensate trap and fill with fresh water</li> <li>• Check for leaks (water, gas, flue, condensate)</li> <li>• Verify flue and air lines in good condition and sealed tight</li> <li>• Check system water pressure/system piping/expansion tank</li> <li>• Check control settings</li> <li>• Ignition electrode (sand off any white oxide; clean and reposition)</li> <li>• Ignition and ground wiring</li> <li>• Wiring and connections</li> <li>• Perform start-up checkout and performance verification per pages 23 through 26</li> <li>• Flame inspection (stable, uniform)</li> <li>• Flame signal (at least 4 VDC)</li> <li>• Clean heat exchanger if flue temp more than 54°F above return water temp</li> </ul>	<b>Monthly</b>	<ul style="list-style-type: none"> <li>• Check vent piping</li> <li>• Check air piping</li> <li>• Check relief valve</li> <li>• Check condensate drain system</li> <li>• Check automatic air vents (if used)</li> </ul>
	<b>Additional if combustion or performance indicate need:</b>	<b>Periodically</b>	<ul style="list-style-type: none"> <li>• Test low water cutoff (if used)</li> </ul>
	<ul style="list-style-type: none"> <li>• Clean heat exchanger</li> <li>• Remove and clean burner using compressed air only</li> <li>• Vacuum the blower</li> </ul>	<b>Every 6 months</b>	<ul style="list-style-type: none"> <li>• Check boiler piping (gas and water)</li> <li>• Operate relief valve</li> </ul>
	<b>Review:</b>	<b>End of season</b>	<ul style="list-style-type: none"> <li>• Shut boiler down (unless boiler used for domestic water)</li> </ul>
<ul style="list-style-type: none"> <li>• Review with owner</li> </ul>			

**WARNING**

Follow the Service and maintenance procedures given throughout this manual and in component literature shipped with the boiler. Failure to perform the service and maintenance could result in damage to the boiler or system. Failure to follow the directions in this manual and component literature could result in severe personal injury, death or substantial property damage.

---

## Annual startup

**WARNING** The boiler should be inspected and started annually, at the beginning of the heating season, only by a qualified service technician. In addition, the maintenance and care of the boiler designated in Table 5 and explained on the following pages must be performed to assure maximum boiler efficiency and reliability. Failure to service and maintain the boiler and system could result in equipment failure.

**WARNING** Electrical shock hazard — Turn off power to the boiler before any service operation on the boiler except as noted otherwise in this instruction manual. Failure to turn off electrical power could result in electrical shock, causing severe personal injury or death.

---

## Handling ceramic fiber materials

### REMOVAL OF COMBUSTION CHAMBER LINING

**WARNING** The combustion chamber lining in this product contains ceramic fiber material. Ceramic fibers can be converted to cristobalite in very high temperature applications. The International Agency for Research on Cancer (IARC) has concluded, "Crystalline silica inhaled in the form of quartz or cristobalite from occupational sources is carcinogenic to humans (Group 1).":

- Avoid breathing dust and contact with skin and eyes.
  - Use NIOSH certified dust respirator (N95). This type of respirator is based on the OSHA requirements for cristobalite at the time this document was written. Other types of respirators may be needed depending on the job site conditions. Current NIOSH recommendations can be found on the NIOSH web site at <http://www.cdc.gov/niosh/homepage.html>. NIOSH approved respirators, manufacturers, and phone numbers are also listed on this web site.
  - Wear long-sleeved, loose fitting clothing, gloves, and eye protection.
- Apply enough water to the combustion chamber lining or base insulation to prevent airborne dust.
- Remove combustion chamber lining or base insulation from the boiler and place it in a plastic bag for disposal.
- Wash potentially contaminated clothes separately from other clothing. Rinse clothes washer thoroughly.

### NIOSH stated First Aid.

- Eye: Irrigate immediately
- Breathing: Fresh air.

---

### Address reported problems

1. Inspect any problems reported by owner and correct before proceeding.

### Inspect boiler area

1. Verify that boiler area is free of any combustible materials, gasoline and other flammable vapors and liquids.
2. Verify that air intake area is free of any of the contaminants listed on page 8 of this manual. If any of these are present in the boiler intake air vicinity, they must be removed. If they cannot be removed, reinstall the air and vent lines per this manual and the Ultra Boiler Vent Supplement.

### Inspect boiler interior

1. Remove jacket front door and inspect interior of boiler.
2. Remove the venturi air inlet silencer and clean if necessary. Replace silencer.
3. Vacuum any sediment from the inside of the boiler and components. Remove any obstructions.

**WARNING** Do not use solvents to clean any of the boiler components. The components could be damaged, resulting in unreliable or unsafe operation.

## Annual startup *(continued)*

### Clean condensate trap

1. Loosen condensate trap line hose clamps and remove trap line.
2. Empty water from trap line and inspect. Flush out if needed with fresh water.
3. Check condensate elbow and tee and condensate line to drain. Flush if necessary to clean.
4. Replace condensate trap line and tighten hose clamps.
5. Fill trap with fresh water by pouring into upturned end of PVC condensate tee.

### Check all piping for leaks

#### WARNING

Eliminate all system or boiler leaks. Continual fresh make-up water will reduce boiler life. Minerals can build up in sections, reducing heat transfer, overheating heat exchanger, and causing heat exchanger failure. Leaking water may also cause severe property damage.

1. Inspect all water and gas piping and verify to be leak free.
2. Look for signs of leaking lines and correct any problems found.
3. Check gas line using procedure on page 21.

### Check air openings

1. Verify that combustion and ventilation air openings to the boiler room and/or building are open and unobstructed. Check operation and wiring of automatic combustion air dampers, if used.
2. Verify that boiler vent discharge and air intake are clean and free of obstructions.

### Flue vent system and air piping

1. Visually inspect entire flue gas venting system (and air piping, if installed) for blockage, deterioration or leakage. Repair any joints that show signs of leakage in accordance with vent manufacturer's instructions. When air is ducted to boiler, verify that air inlet hose is connected and properly sealed.

#### WARNING

Failure to inspect for the above conditions and have them repaired can result in severe personal injury or death.

### Check water system

1. Verify all system components are correctly installed and operational.
2. Check the cold fill pressure for the system. Verify it is correct (usually around 12 psig).
3. Watch the system pressure as the boiler heats up (during testing) to ensure pressure doesn't rise too high. Excessive pressure rise indicates expansion tank sizing or performance problem.
4. Inspect automatic air vents and air separators. Remove air vent caps and briefly press push valve to flush vent. Replace caps. Make sure vents do not leak. Replace any leaking vents.

### Check expansion tank

1. Expansion tanks provide space for water to move in and out as the heating system water expands due to temperature increase or contracts as the water cools. Tanks may be open, closed or diaphragm or bladder type. See section 3 of this manual for suggested best location of expansion tanks and air eliminators.

**Open-type** — located above highest radiator or baseboard unit, usually in the attic or closet. Has a gauge glass and overflow pipe to a drain.

**Closed-type** — welded gas tight and located above boiler. Tank is partially filled with water, leaving an air cushion for expansion.

- Make sure this type of tank is fitted with a tank fitting, such as the B & G Tank-Trol or Taco Taco-Trol. This fitting reduces gravity circulation of air-saturated tank water back to the system and prevents the air from bubbling up through the water as it returns from the system.
- Do not use automatic air vents in systems with closed-type tanks. The air will escape from the system instead of returning to the tank. Eventually, the tank will waterlog and no longer control pressurization. The boiler relief valve will weep frequently.

**Diaphragm- or bladder-type** — welded gas tight with a rubber membrane to separate the tank pressurizing air and the water. May be located at any point in the system, but most often found near the boiler.

- Systems with this type of expansion tank require at least one automatic air vent, preferably located on top of an air eliminator, as shown in examples in manual section 3.

2. If relief valve has tended to weep frequently, the expansion tank may be waterlogged or undersized.

**Closed-type tank** — tank is most likely waterlogged. Install a tank fitting if not already installed. Then check fill level per fitting manufacturer's instructions. If fill level is correct, check tank size against manufacturer's instructions. Replace with a larger tank if necessary.

**Diaphragm- or bladder-type** — first, check tank size to be sure it is large enough for the system. If size is too small, add additional tank(s) as necessary to provide sufficient expansion. If tank size is large enough, remove tank from system and check charge pressure (usually 12 psig for residential applications). If tank won't hold pressure, membrane has been damaged. Replace tank.

## Annual startup *(continued)*

### Check boiler relief valve

1. Inspect the relief valve and lift the lever to verify flow as in the following warnings, excerpted from a relief valve manufacturer's warning label. Before operating any relief valve, ensure that it is piped with its discharge in a safe area to avoid severe scald potential. Read manual section 3, page 12, before proceeding further.

**WARNING** Safety relief valves should be reinspected AT LEAST ONCE EVERY THREE YEARS, by a licensed plumbing contractor or authorized inspection agency, to ensure that the product has not been affected by corrosive water conditions and to ensure that the valve and discharge line have not been altered or tampered with illegally. Certain naturally occurring conditions may corrode the valve or its components over time, rendering the valve inoperative. Such conditions are not detectable unless the valve and its components are physically removed and inspected. This inspection must only be conducted by a plumbing contractor or authorized inspection agency — not by the owner. Failure to reinspect the boiler relief valve as directed could result in unsafe pressure buildup, which can result in severe personal injury, death or substantial property damage.

**WARNING** Following installation, the valve lever must be operated AT LEAST ONCE A YEAR to ensure that waterways are clear. Certain naturally occurring mineral deposits may adhere to the valve, rendering it inoperative. When manually operating the lever, water will discharge and precautions must be taken to avoid contact with hot water and to avoid water damage. Before operating lever, check to see that a discharge line is connected to this valve directing the flow of hot water from the valve to a proper place of disposal. Otherwise severe personal injury may result. If no water flows, valve is inoperative. Shut down boiler until a new relief valve has been installed.

2. After following the above warning directions, if the relief valve weeps or will not seat properly, replace the relief valve. Ensure that the reason for relief valve weeping is the valve and not over-pressurization of the system due to expansion tank waterlogging or undersizing.

### Inspect ignition electrode

1. Remove the ignition electrode from the boiler heat exchanger access cover.
2. Remove any white oxides accumulated on the ignition electrode using sandpaper. If the ignition electrode cannot be cleaned satisfactorily, replace ignitor with a new one.
3. Replace ignition electrode, making sure gasket is in good condition and correctly positioned.
4. Make sure the electrodes are parallel to each other.

### Check ignition ground wiring

1. Inspect boiler ground wire from heat exchanger access cover to ground terminal strip.
2. Verify all wiring is in good condition and securely attached.
3. Check ground continuity of wiring using continuity meter.
4. Replace ground wires if ground continuity is not satisfactory.

### Check all boiler wiring

1. Inspect all boiler wiring, making sure wires are in good condition and securely attached.

### Check control settings

1. Set the control module display to Parameter mode and check all settings. Adjust settings if necessary. See Ultra Control Supplement for details.
2. Check settings of external limit controls (if any) and adjust if necessary.

## Annual startup *(continued)*

### Perform startup and checks

1. Start boiler and perform checks and tests specified on pages 23 through 26 (and Control Supplement).
2. Verify cold fill pressure is correct and that operating pressure does not go too high.
3. Complete the check-out procedure on page 26.

### Check burner flame

#### WARNING

The boiler contains ceramic fiber materials. Use care when handling these materials per instructions on page 29 of this manual. Failure to comply could result in severe personal injury.

1. Inspect flame through observation window using the procedure on page 25.
2. If flame is unsatisfactory at either high fire or low fire, turn off boiler and allow boiler to cool down. Then remove burner and clean it thoroughly using a vacuum cleaner or compressed air. Do not use compressed air to clean burner if performed inside a building.
3. To access burner, remove the heat exchanger cover plate following the procedure on page 33.
4. When replacing burner, ensure gasket is in good condition and correctly positioned. After tightening the three retainer screws, bend up the retainer tabs as shown in Figure 16 to prevent screw rotation.
5. After servicing, replace boiler components. Retest boiler.

### Check flame signal

1. Flame signal (DC volts from low voltage terminal strip terminal 9 to ground) should be at least 4 VDC.
2. A lower flame signal may indicate a fouled ignitor or damaged ignitor insulation. If cleaning the ignitor does not improve, ground wiring is in good condition, and ground continuity is satisfactory, replace the ignitor.
3. See Troubleshooting in the Ultra Control Supplement for other procedures to deal with low flame signal.

### Check flue gas temperature

1. Place the control display in Information mode while the boiler is operating at high fire. See Ultra Control Supplement for details.
2. The flue gas temperature (electronic display first digit shows "5") must not be more than 60°F higher than the return water temperature (display first digit shows "2").
3. If the flue temperature is higher than this, shut down the boiler, allow to cool, and follow the procedure on pages 33 through 34 to clean the heat exchanger.

### Review with owner

1. Review the User's Information Manual with the owner.
2. Emphasize the need to perform the maintenance schedule specified in the User's Information Manual (and in this manual as well).
3. Remind the owner of the need to call a licensed contractor should the boiler or system exhibit any unusual behavior.
4. Remind the owner to follow the proper shutdown procedure and to schedule an annual startup at the beginning of the next heating season.

Figure 16 Burner assembly

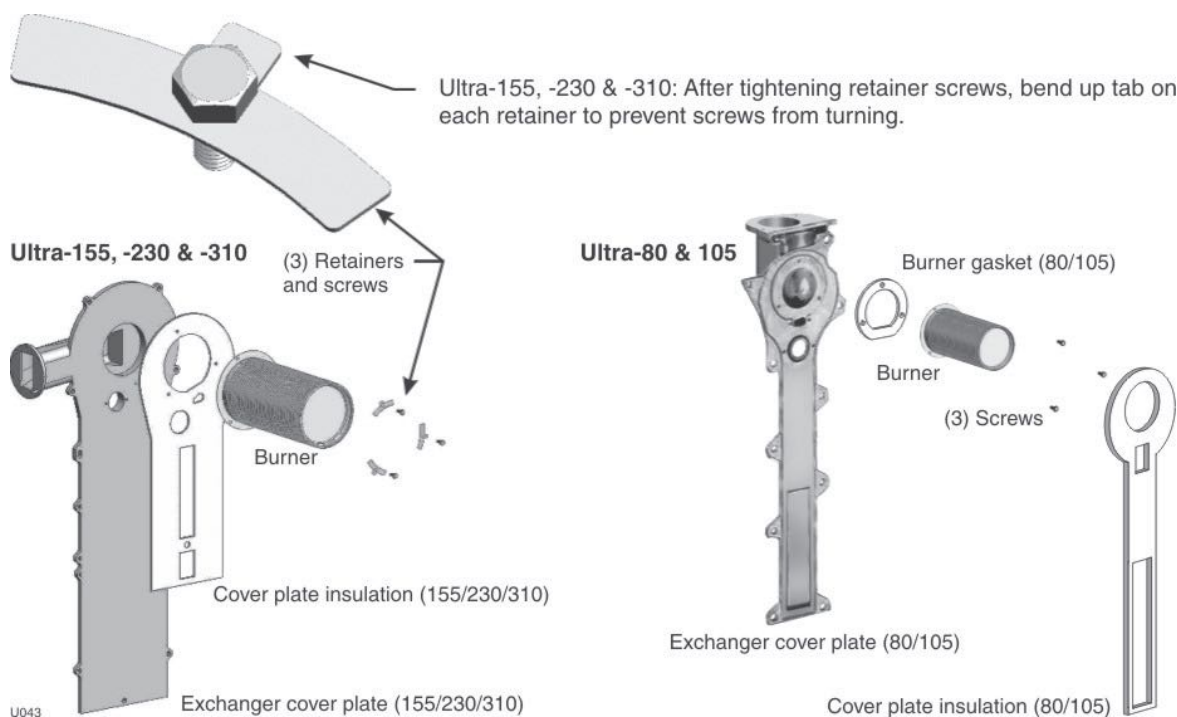



## Maintenance — general

### Replace boiler jacket front door after startup or servicing

**WARNING**

Replace boiler jacket front door after start or servicing. The boiler front door must be securely fastened to the boiler to prevent boiler from drawing air from inside the boiler room. This is particularly important if the boiler is located in the same room as other appliances. Failure to keep the door securely fastened could result in severe personal injury or death.

### General maintenance

1. Oil motor in system requiring regular oiling.
2. See Oil bearing circulators for motor oiling procedures.

### Oiled bearing circulators

1. The circulator shipped with the Ultra boiler is water-lubricated. No oiling is required.
2. Check other circulators in the system. Oil any circulators requiring oil, following circulator manufacturer's instructions. Over-oiling will damage the circulator.

### Cleaning boiler heat exchanger

**WARNING**

The boiler contains ceramic fiber materials. Use care when handling these materials per instructions on page 29 of this manual. Failure to comply could result in severe personal injury.

1. Shut down boiler:
  - a. Follow "To Turn Off Gas to Appliance" instructions on boiler and Lighting instructions.
  - b. Do not drain boiler unless it will be exposed to freezing temperatures. If using freeze prevention fluid in system, do not drain.
2. Allow time for boiler to cool to room temperature if it has been firing.
3. Remove jacket front door by removing two knurled head screws at lower front. Lift door away from boiler to remove.
4. Follow procedure below to access the heat exchanger interior.

#### Access exchanger: Ultra-80 and Ultra-105 Only

1. Remove (4) Phillips-head screws securing gas valve inlet adapter to gas valve. This will disconnect the gas valve from the gas line.

2. Remove the air silencer by separating it from the air adapter on the blower inlet.
3. Disconnect the gas valve plug, blower power supply plug and blower control connector.
4. Release the exchanger cover plate by removing the nuts securing it to the exchanger.
5. Pull the entire blower/venturi/gas valve/cover plate assembly out of the boiler. (See pages 39 or 41 for component identification and locations.)
6. Use a vacuum cleaner to remove any accumulation on the heating surfaces. Do not use any solvent.
7. If the vacuum cleaner is unable to clean completely, wash the heating surfaces with clean, warm water. If necessary, use a piece of 20-gauge or lighter sheet metal  $\frac{3}{4}$ " wide by about 18 inches long to loosen deposits.
8. Inspect the heat exchanger cover plate insulation. Replace if insulation is damaged. Read the ceramic fiber WARNING on page 29 before handling or disposing of ceramic fiber materials.
9. Re-install the blower/venturi/gas valve/cover plate assembly and secure the cover plate with nuts.
10. Connect gas valve electrical plug and blower power and control connectors.

**DANGER**

Inspect the O-ring that should still be in the gas valve inlet adapter block. The O-ring must be in good condition and must be installed when gas valve is reconnected. Failure to comply will cause a gas leak, resulting in severe personal injury or death.

11. Secure gas valve inlet adapter to gas valve with (4) Phillips-head screws.
12. Re-install the air silencer by pressing onto the air inlet adapter.
13. Install access cover gasket, chamber insulation assembly and cover. Secure cover with nuts.
14. See continued instructions on next page.

## Maintenance and annual startup *(continued)*

### Cleaning boiler heat exchanger

*(continued from previous page)*

#### Access exchanger: Ultra-155, -230, -310 Only

1. Remove gas valve electrical plug from gas valve. Also remove two electrical molex plugs from blower assembly.
2. Disconnect gas line union with pipe wrench or Channel Lock Pliers.
3. Remove air silencer by lifting plastic clamp off gas line and then gently sliding air silencer down and off valve.
4. Remove two 5/32" Allen head screws securing blower assembly to heat exchanger front cover.
5. Remove blower and gas valve assembly.
6. Remove hex head nuts (10mm box end wrench) from burner cover plate and remove burner cover plate from heat exchanger.
7. Remove three M4 hex head screws (7mm box end wrench) and burner clips securing burner to cover plate. Remove cover plate.
8. Use a vacuum cleaner to remove any accumulation on the heating surfaces. Do not use any solvent.
9. If the vacuum cleaner is unable to clean completely, wash the heating surfaces with clean, warm water. If necessary, use a piece of 20-gauge or lighter sheet metal  $\frac{3}{4}$ " wide by about 18 inches long to loosen deposits.
10. Inspect the heat exchanger cover plate insulation and gasket. Replace if damaged. Read the ceramic fiber WARNING on page 29 before handling or disposing of ceramic fiber materials.
11. Place cover plate gasket in groove of heat exchanger cover plate. Replace cover plate.
12. Re-install hex head nuts (10mm box end wrench) on cover plate mounting studs and tighten in a staggering pattern until cover plate is uniformly tightened.
13. Re-install blower insuring new gasket, provided in this kit, is in proper alignment between blower and heat exchanger front cover.
14. Re-install air silencer by sliding on gas valve venturi and securing clamp to gas line.
15. Connect the two blower electrical molex plugs.
16. Re-connect gas valve union and gas valve electrical plug.

#### Exchanger cleaning continued (ALL models)

1. Close isolation valves on piping to isolate boiler from system. Attach a hose to boiler drain valve and flush boiler thoroughly with clean water by using purging valves to allow water to flow through water make-up line to boiler.
2. When boiler has been flushed, restore boiler to operation.
3. Perform startup and checkout procedures of pages 23 and 26.
4. Turn on gas supply and check for gas leaks.

#### WARNING

Failure to properly check for gas leaks can cause severe personal injury, death, or substantial property damage.

5. Turn on boiler electrical supply and test boiler for proper operation as stated in the Ultra Boiler Manual.
6. Replace boiler jacket front door when servicing is completed. See Warning at top of page 33.

## Replacement parts

**WARNING**

Replacement parts must be purchased through a local Weil-McLain distributor. When ordering, specify boiler model and size and include description and part number of replacement part. Results from using modified or other manufactured parts will not be covered by warranty and may damage boiler or impair operation.

**NOTICE**

Weil-McLain part numbers are found in Weil-McLain Boilers and Controls Repair Parts Lists.

**WARNING**

The boiler contains ceramic fiber materials. Use care when handling these materials per instructions on page 29 of this manual. Failure to comply could result in severe personal injury.

### Replace boiler jacket front door after startup or servicing

**WARNING**

Replace boiler jacket front door after start or servicing. The boiler front door must be securely fastened to the boiler to prevent boiler from drawing air from inside the boiler room. This is particularly important if the boiler is located in the same room as other appliances. Failure to keep the door securely fastened could result in severe personal injury or death.

## Miscellaneous parts and kits

Item	Description	Part Number
1	Pressure relief valve, ASME 30 PSI, ¾" npt male, (watts #330)	383-500-095
2	Boiler circulator, without flanges Ultra-80 & -105 . . . . . Taco Model 007 Ultra-155, -230 & -310 . Taco Model 0011	511-405-113 511-405-124
3	Circulator hardware kit – inlet, 1" (1 flange, 2 nuts, 2 screws, and 1 gasket) (Ultra-80 to -230)	381-354-525
4	Circulator hardware kit (flange, nuts, screws, and gasket) Ultra-80 to -310, 1¼" Ultra-310, 1½"	381-354-526 381-354-531
5	Sidewall vent termination kit 3" vent 4" vent	383-500-397 383-500-398
6	Vent termination bird screen (2 required for Ultra-80, -105 & -155)	3" vent 383-500-105
7	Vent termination bird screen (2 required for Ultra-230 & -310 only)	4" vent 383-500-110
8	Natural to propane conversion kit for Ultra-80 Natural to propane conversion kit for Ultra-105 (orifice bag assembly)	383-501-020 540-100-001
9	Propane to natural conversion kit for Ultra-80	383-501-021
10	Natural to propane conversion kit for Ultra-155 (orifice bag assembly) Natural to propane conversion kit for Ultra-230 (orifice bag assembly) Natural to propane conversion kit for Ultra-310 Series 2 (orifice bag assembly)	383-500-115 383-500-120 540-202-831
11	Alarm control kit	383-500-080
12	Outdoor temperature sensor	383-500-125

**Replacement parts** *(continued)***Jacket parts**

Item	Description	Part Number
1	Jacket front door	383-500-135
2	Boiler leg kit	4 Required 383-500-065
3	Knurled head screw for jacket front door	2 Required 383-500-320
4	Knurled head screw clip-on receptacle (not shown)	2 Required 383-500-180
5	Flue temperature sensor replacement kit	383-500-055
6	Air adapter assembly (Includes adapter, gasket and mounting bracket)	
	Ultra-80, -105, -155, 3"	383-500-145
	Ultra-230, -310, 4"	383-500-150
7	Flue outlet pipe adapter	Ultra-80 & -105, 3" Ultra-155, 3" Ultra-230, -310, 4" 560-900-001 383-500-155 383-500-160
8	Top cover, front	383-500-165
9	Top cover, rear	Ultra-80 to -230 Ultra-310 383-500-170 595-000-006
10	Electrical cabinet door	383-500-175

## Replacement parts *(continued)*

### Jacket parts

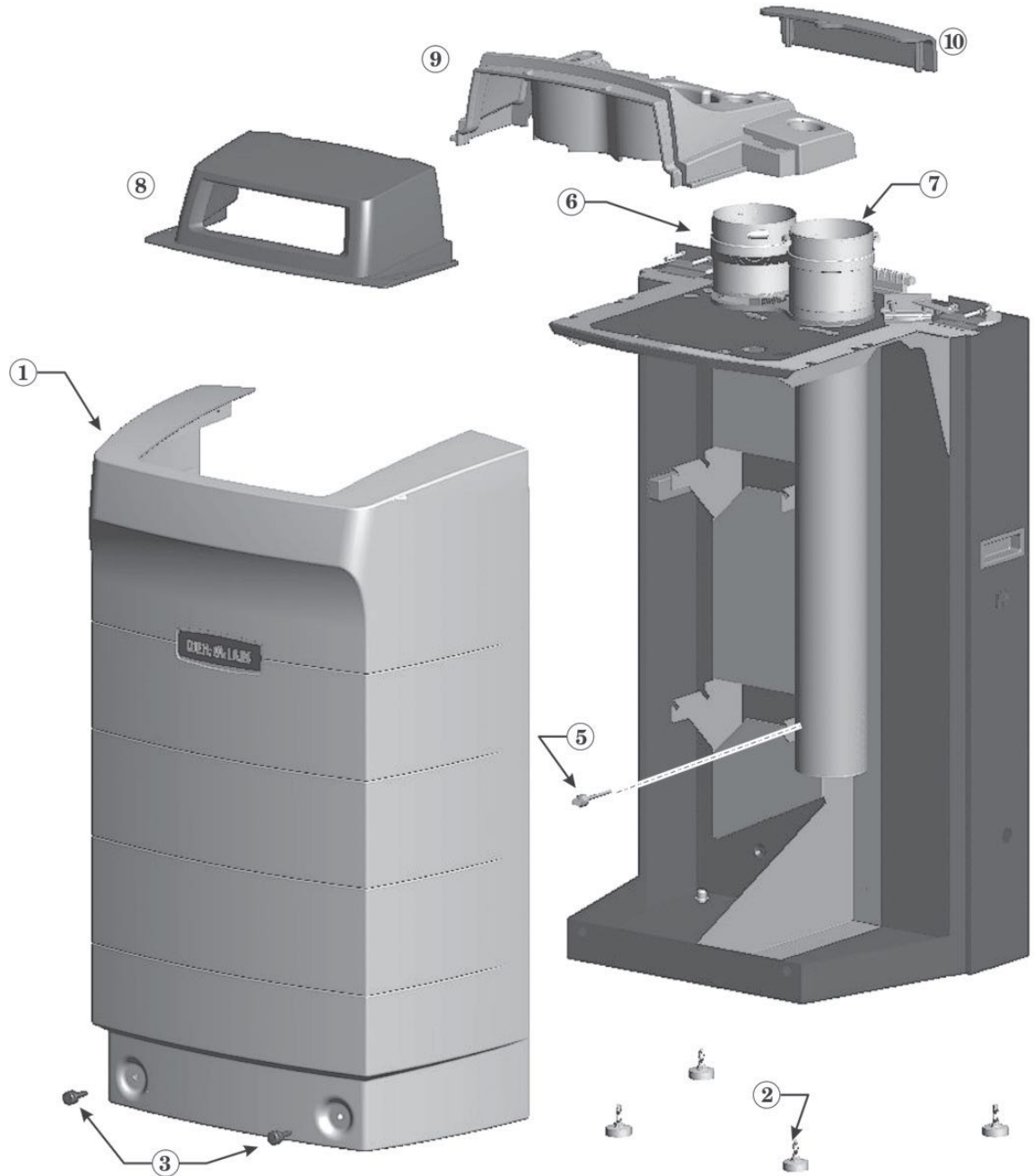

U034

## Replacement parts *(continued)*

### Heat exchanger and piping — Ultra-80 & -105

Item	Description	Boiler Models	Part Number
1	Heat exchanger replacement kit — Heat exchanger, cover plate, burner, electrode, water sensors, compression fittings, condensate fitting, gaskets, and hardware	Ultra-80NG Ultra-80LP Ultra-105	383-501-023 383-501-024 383-501-035
2	Cover plate replacement kit — Cover plate, cover plate gasket, burner gasket, and hardware	Ultra-80, -105	383-501-022
3	Cover plate gasket/insulation	Ultra-80, -105	591-200-000
6	Burner gasket	Ultra-80, -105	590-300-000
7	Water compression fitting, 28 mm	Ultra-80, -105	383-500-260
8	Water compression fitting, 22 mm	Ultra-80, -105	564-100-002
9	Water supply piping assembly — Pipe, temperature well, check valve, cap (assembled) & compression fitting	Ultra-80, -105	383-501-036
10	½" NPT well for temperature gauge	All	383-500-270
11	Pressure/temperature gauge check valve	All	383-500-275
15	Return water pipe assembly — Pipe, drain valve, cap (assembled) & compression fitting	Ultra-80, -105	383-501-037
17	Boiler drain valve, ¾" NPT	All	511-246-392
18	Blower assembly kit — Blower, gasket, and hardware	Ultra-80, -105	383-501-027
19	Gas pipe assembly — Gas pipe, shut-off valve, 1 1/2" nipple, adapter block, O-ring, and hardware	Ultra-80, -105	383-501-038
20	Gas valve/venturi kit — Gas Valve, venturi, 90° elbow, gaskets, and hardware (assembled) (For LP boilers, make sure to reinstall the existing propane orifice.)	Ultra-80	383-501-029
	Gas valve/venturi kit — Gas Valve, venturi, 90° elbow, gaskets, and hardware (assembled) (For LP boilers, make sure to reinstall the existing propane orifice.)	Ultra-105	383-501-030
22	Manual gas valve, ½" NPT	Ultra-80, -105	Obtain locally
23	Air silencer kit — Air silencer and gasket	Ultra-80, -105	383-501-026
24	Air silencer adapter kit — Air silencer adapter and hardware	Ultra-80, -105	383-501-025
25	Condensate trap kit — Condensate trap, hose clamps, pvc fittings, and gasket	Ultra-80, -105	383-501-031
26	Ignition electrode kit — Ignition electrode, suppressor, gasket, and hardware	All	383-500-045
27	Ignition cable kit (not shown) — Ignition cable, suppressor, and wire tie	All	383-500-050
28	Inspection glass kit — Bracket, glass, gasket, and hardware	All	383-500-020
29	Burner replacement kit — Burner, gaskets and hardware	Ultra-80NG Ultra-80LP Ultra-105	383-501-032 383-501-033 383-501-034
30	Gasket	Ultra-80, -105	590-300-003
31	Condensate fitting	Ultra-80, -105	561-200-000
32	Return/supply sensor kit — (1) sensor	All	383-500-300

## Replacement parts *(continued)*

### Heat exchanger and piping — Ultra-80 & -105

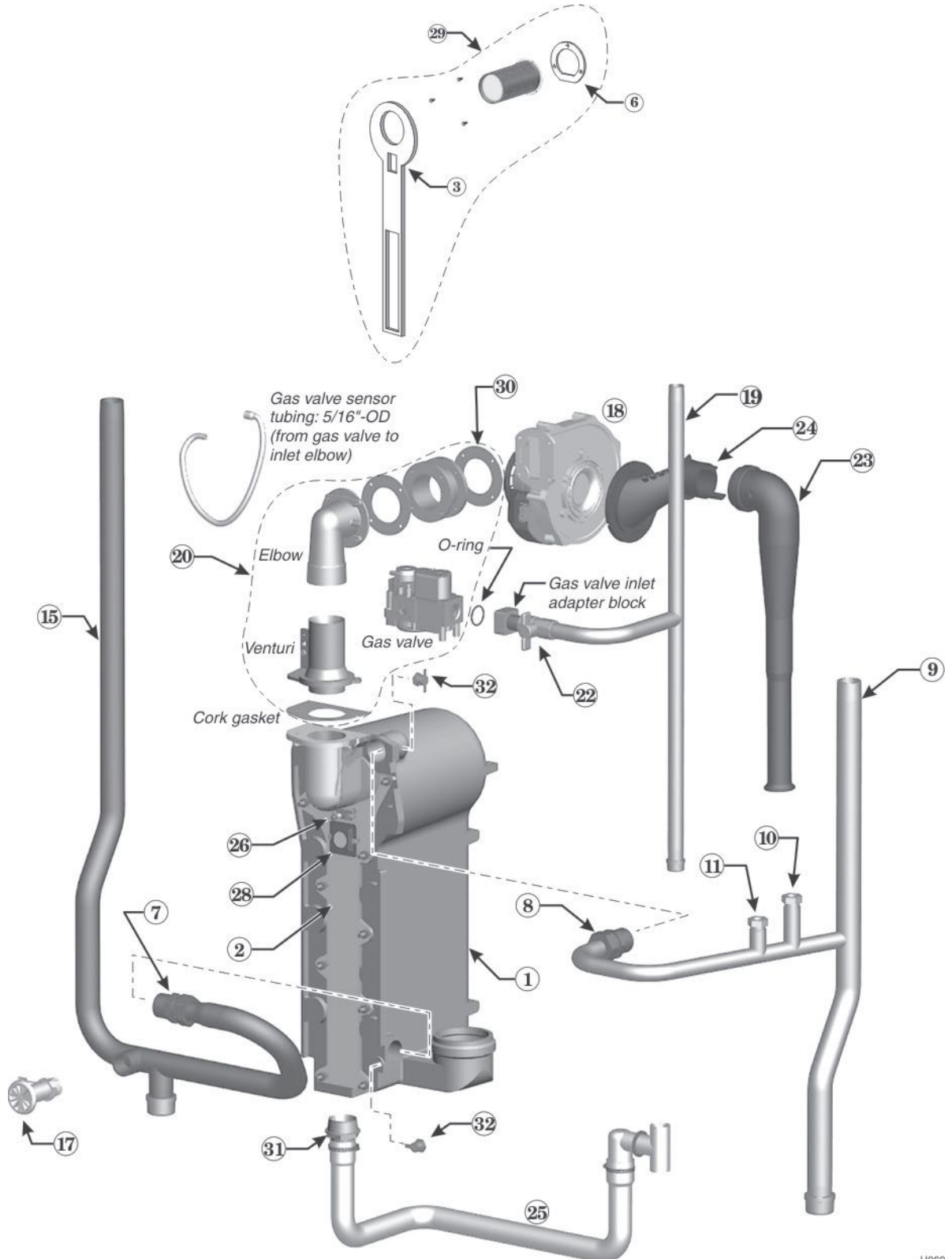

## Replacement parts *(continued)*

### Heat exchanger and piping — Ultra-155 to -310

Item	Description	Boiler Models	Part Number
1	Heat exchanger replacement kit — Heat exchanger, cover plate, burner, electrode, water sensors, compression fittings, gaskets, and hardware	Ultra-155 Ultra-230 Ultra-310	383-500-070 383-500-075 383-500-375
2	Cover plate replacement kit — Cover plate, cover plate gasket, burner gasket, and hardware	-155/-230/-310	383-500-395
4	Cover plate insulation	-155/-230/-310	383-500-250
5	Cover plate gasket (not shown)	-155/-230/-310	383-500-255
7	Water compression fitting, 28 mm	Ultra-155/-230	383-500-260
9	Water supply piping assembly — Pipe, temperature well, check valve, cap (assembled) & compression fitting	Ultra-155/-230 Ultra-310	383-501-036 383-500-380
10	½" NPT well for temperature gauge	All	383-500-270
11	Pressure/temperature gauge check valve	All	383-500-275
14	Return water bushing, 1¼" BSP x 1" BSP (not used on Ultra-310)	Ultra-155/-230	383-500-280
15	Return water pipe assembly — Pipe, drain valve, cap (assembled) & compression fitting	Ultra-155/-230 Ultra-310	383-500-285 383-500-385
17	Boiler drain valve, ¾" NPT	All	511-246-392
18	Blower assembly kit — Blower, gasket, and hardware	Ultra-155	383-500-035
	Blower assembly kit — Blower, gasket, molex adapter, and hardware	Ultra-230	383-500-040
	Blower assembly kit — Blower, gasket, and hardware	Ultra-310	383-500-360
19	Gas pipe assembly — Gas pipe and shut-off valve	Ultra-155/-230 Ultra-310	383-500-290
	Gas pipe (Ultra-310 only)		560-907-679
19a	Flexible gas line section and shut-off valve (Ultra-310 only)	Ultra-310	560-900-016
20	Gas valve/venturi kit — Gas Valve/venturi assembly, adapter block, O-ring and hardware (For LP boilers, make sure to reinstall the existing propane orifice.)	Ultra-155 Ultra-230 Ultra-310	383-500-025 383-500-030 383-500-390
21	Ground joint union, ½" NPT	Ultra-155/-230	Obtain locally
22	Manual gas valve, ½" NPT	Ultra-155/-230	Obtain locally
23	Air silencer kit — Air silencer and gasket	Ultra-155/-230 Ultra-310	383-500-295 383-500-355
25	Condensate trap kit — Condensate trap, hose clamps, pvc fittings, and gasket	Ultra-155 Ultra-230 Ultra-310	383-501-031 383-500-060 383-500-365
26	Ignition electrode kit — Ignition electrode, suppressor, gasket, and hardware	All	383-500-045
27	Ignition cable kit (not shown) — Ignition cable, suppressor, and wire tie	All	383-500-050
28	Inspection glass kit — Bracket, glass, gasket, and hardware	All	383-500-020
29	Burner replacement kit — Burner, gaskets and hardware	Ultra-155 Ultra-230 Ultra-310	383-500-085 383-500-090 383-500-407
32	Return/supply sensor kit — (1) sensor	All	383-500-300



## Replacement parts *(continued)*

### Heat exchanger and piping — Ultra-155 to -310

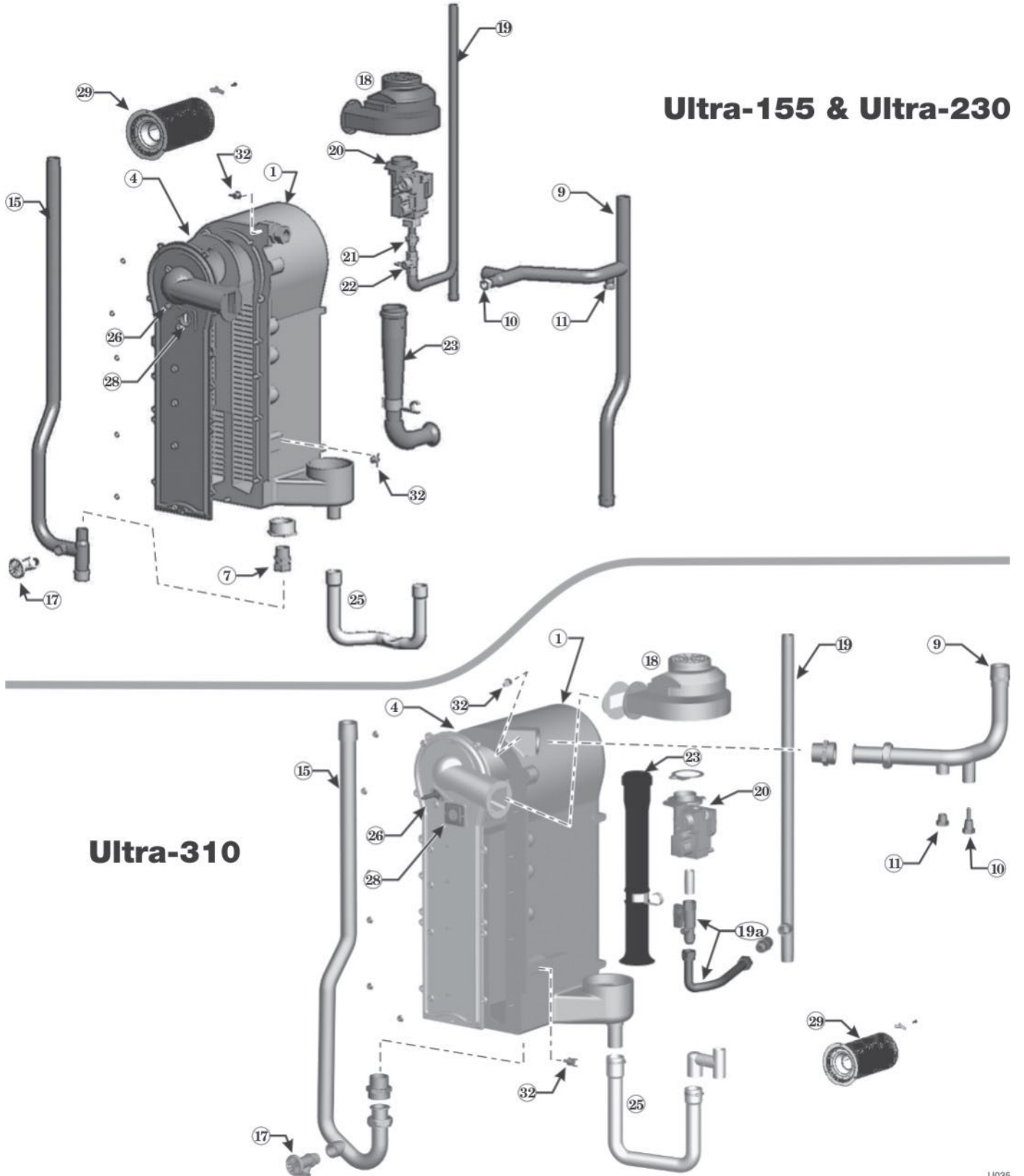

## Replacement parts *(continued)*

### Controls

Item	Description	Part Number
1	Ultra control module Ultra-80/105/155/230 Ultra-310	383-500-190 511-330-258
2	Transformer, 120v/24v	383-500-195
3	Display board kit (Includes display with data port, bracket, label, off-set and dust cover)	383-500-408
4	On/off power switch	383-500-205
5	Pressure/temperature gauge assy., (Includes temperature and pressure sensor)	383-500-210
6	Ribbon cable, control module to display board	383-500-215
7	Low voltage wire harness assembly for Ultra-80 & -105 (not shown) Low voltage wire harness assembly for Ultra-155 & -230 (not shown) Low voltage wire harness assembly for Ultra-310 (not shown)	591-300-002 383-500-220 591-391-941
8	Line voltage wire harness assembly for Ultra-80 & -105 (not shown) Line voltage wire harness assembly for Ultra-155 & -230 (not shown) Line voltage wire harness assembly for Ultra-310 (not shown)	591-300-001 383-500-230 591-391-940
9	Control module fuses (not shown) F1 — 5-amp, fast-blow (5 fuses) F3 — 4-amp, slow-blow (5 fuses)	383-500-235 383-500-240
10	120 volt, 3-wires receptacle (not shown)	383-500-245
11	Circulator relay (Ultra-310 only, not shown) White-Rodgers 90-362 SPST, 120 VAC	510-350-200

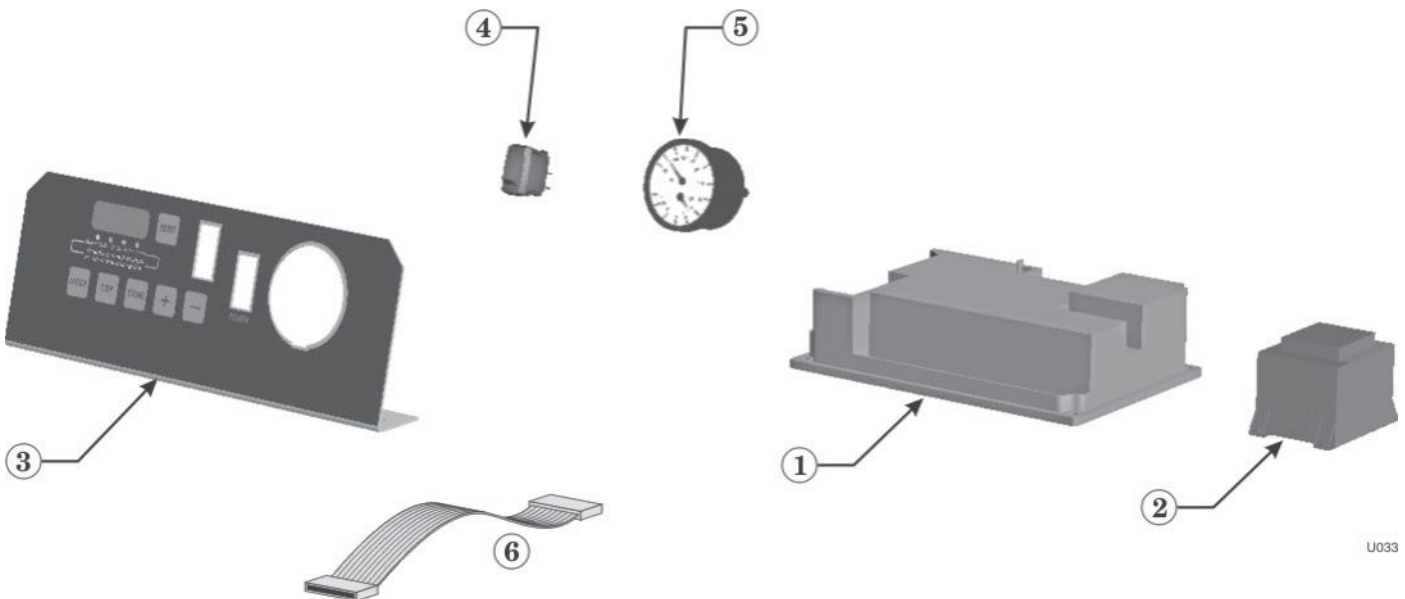

U033

### Dimensions

① Supply connection (note 1)

② Return connection (note 1)

③ Low voltage wire opening

④ Electrical entrance openings

⑤ Vent connection:  
Ultra-80, -105, & -155 — 3"  
Ultra-230 & -310 — 4"

ALL DIMENSIONS IN INCHES

⑥ Pressure/temperature gauge

⑦ Gas connection (note 1)

⑧ Drain valve (inside enclosure)

⑨ Condensate drain (1/2" PVC)

⑩ Air connection:  
Ultra-80, -105, & -155 — 3"  
Ultra-230 & -310 — 4"

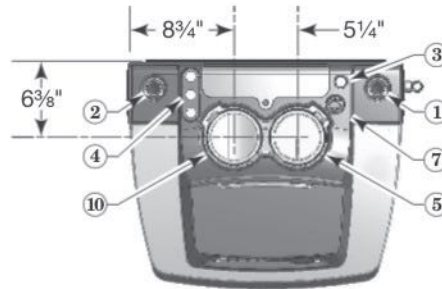

TOP

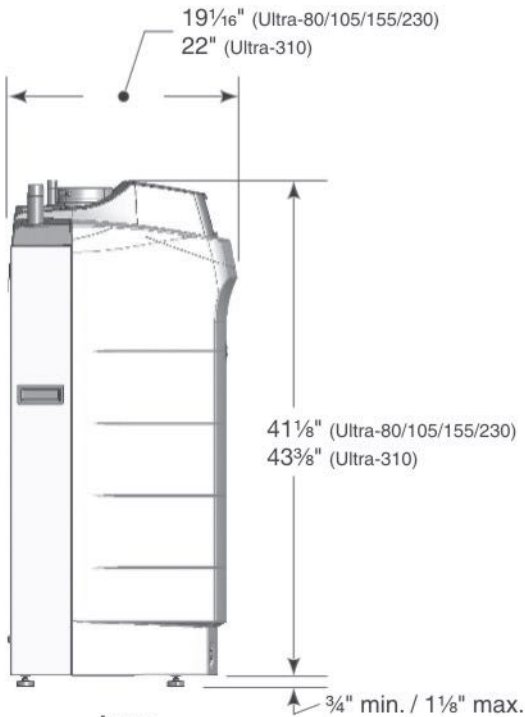

U037

LEFT

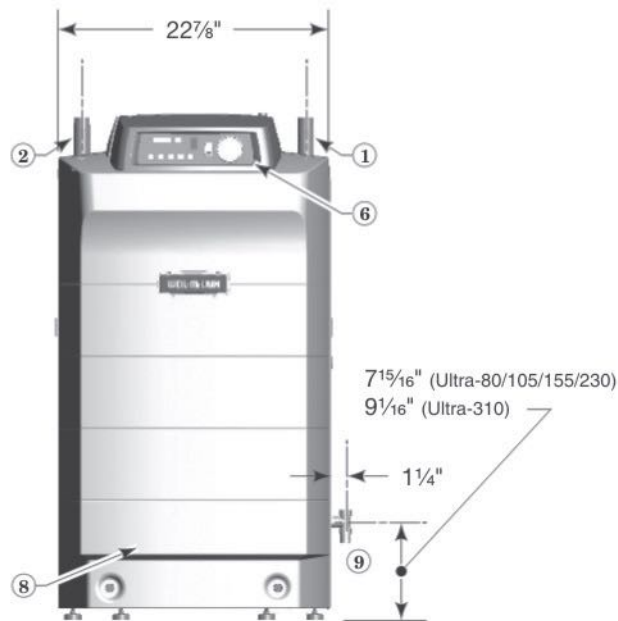

FRONT



RIGHT

#### Notes

- Boiler supply and return tappings are both 1" NPT (Ultra-80/105/155/230) or 1 1/4" NPT (Ultra-310). See pages 14 through 18 for recommended system supply and return piping sizes. Wall-hung boilers: water piping and gas pipe can be routed through bottom of enclosure using wall-mounting kit.
- Boiler circulator is shipped loose. Circulator may be mounted on either boiler supply or return piping. Both 1"

and 1 1/4" circulator flanges are shipped with boiler on Ultra-80/105/155/230. Both 1 1/4" and 1 1/2" circulator flanges are shipped with boiler on Ultra-310.

- Relief valve is shipped loose. See page 11 for mounting details. Relief valve mounts on supply pipe off of supply tee and 3/4" street elbow as shown.

### Ratings



DOE



Boiler Model Number	DOE Heating Capacity	CSA Input	CSA Output	Net I=B=R Ratings	Boiler Water Content	DOE Seasonal Efficiency	Weil-McLain Low temperature seasonal efficiency	Vent Size
	Btuh (Note 2)	Btuh (Note 9)	Btuh (Note 9)	Btuh (Note 3)	Gallons	AFUE, % (Note 1)	% (Note 5)	(Note 4)
Ultra-80	71,000	80,000	71,000	62,000	0.69	93.0	98.0	3"
Ultra-105	94,000	105,000	94,000	81,000	0.82	92.0	98.0	3"
Ultra-155	139,000	155,000	139,000	123,000	1.17	93.0	98.0	3"
Ultra-230	207,000	230,000	207,000	183,000	1.57	92.8	98.0	4"

Boiler Model Number	CSA Input	CSA Gross Output	Net I=B=R Ratings	Boiler Water Content	Combustion Efficiency	Thermal Efficiency	Weil-McLain Low temperature efficiency		Vent Size
							Combustion	Thermal	
	Btuh (Note 9)	Btuh (Note 9)	Btuh (Note 3)	Gallons	% (Note 6)	% (Note 7)	% (Note 8)		(Note 4)
Ultra-310	310,000	289,000	252,000	2.1	93.3	92.9	95.6	95.2	4"

- Notes**
- As an Energy Star Partner, Weil-McLain has determined that Ultra boilers meet the Energy Star guidelines for energy efficiency.
  - Based on standard test procedures prescribed by the United States Department of Energy.
  - Net I=B=R ratings are based on net installed radiation of sufficient quantity for the requirements of the building and nothing need be added for normal piping and pickup. Ratings are based on a piping and pickup allowance of 1.15. An additional allowance should be made for unusual piping and pickup loads.
  - Ultra boilers require special venting, consistent with Category IV boiler. Use only the vent materials and methods specified in Ultra vent supplements. Ultra boilers must be direct-vented. Ultra-230 can be vented with either 3" or 4" vent pipe. Vent length limits for 3" vent are not as long as for 4" vent.
  - Weil-McLain Low temperature seasonal efficiency is based on ASHRAE 103 test method, using boiler return water temperature of 90°F, with boiler outlet water temperature of 110°F.
  - Combustion efficiency is based on I=B=R testing procedure BTS-2000, and equal to 100% minus flue loss.
  - Thermal efficiency is based on I=B=R testing procedure BTS-2000.
  - Weil-McLain Low temperature efficiency is based on the I=B=R testing procedures, using boiler return water temperature of 90°F and boiler outlet water temperature of 110°F.
  - Ratings shown are for sea level applications only. For altitudes from sea level to 5,500 feet above sea level, the Ultra boiler requires no modifications and automatically derates itself by approximately 4% per 1000 feet above sea level. For elevations above 5,500 feet, contact your local Weil-McLain sales office for details.



Weil-McLain  
500 Blaine Street  
Michigan City, IN 46360-2388  
<http://www.weil-mclain.com>