

WEIL-McLAIN

Wm

Boiler Manual for No. 88 Light Oil, Gas-Light Oil, and Gas

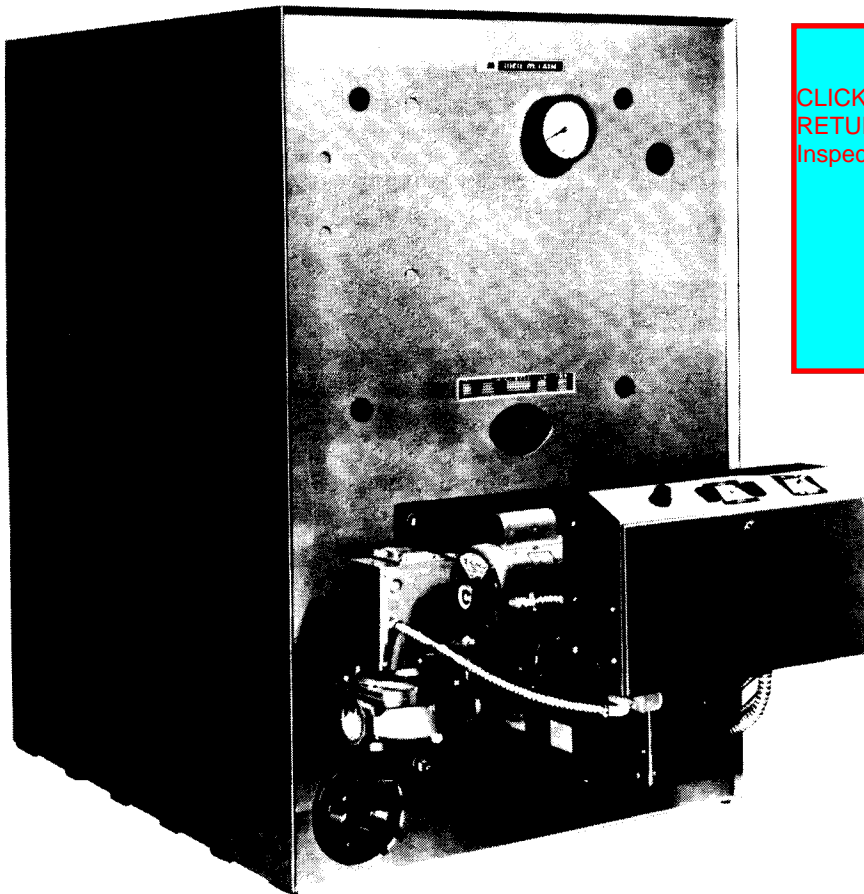

CLICK ANYWHERE on THIS PAGE to
RETURN TO Weil-McLain BOILERS at
InspectApedia.com

Includes:

- Installation
- Start-up
- Service

READ ALL INSTRUCTIONS BEFORE INSTALLING

To the owner: Installation and service should be performed by qualified contractor.
To the installer: Leave all instructions with boiler for future reference.

Any claims for damage or shortage in shipment must be filed immediately against the transportation company by the consignee.



Table of Contents

Section I: Pre-Installation

Codes	3
Air Supply for Combustion	3-4
Minimum Clearances	4
Foundation	4
Chimney or Vent	5

Section II: Assembled Sections or Packaged Boiler . . 6

Section III: Site-Assembly

Installation	6-8
--------------------	-----

Section IV: Hydrostatic Pressure Test

Hydrostatic Pressure Test	9
Control Tapping Table	9

Section V: Supply and Return Piping

Water	10-11
Primary-secondary Piping	11
Steam	12-13
Condensate Receiver	14
Multiple Steam Piping	15

Section VI: Jacket and Heaters

Jacket Installation	16
Heaters	16

Section VII: Boiler Controls

Water	17
Steam	18

Section VIII: Burner Installation19

Section IX: Wiring19

Section X: Fuel Line Piping

Gas	20
Fuel Oil	20

Section XI: Final Adjustment

Filling System	21
Burner and Breeching Damper Adjustment	21
Skimming Steam Boilers	22
Gas Tight Seal	22
Water Treatment	22
Freeze Protection	22

Ratings and Data 23-25

Replacement Parts 26-27

IMPORTANT: When calling or writing about the boiler, PLEASE GIVE THE MODEL, SERIES, AND C.P. NUMBER located on the boiler rating nameplate.

Any reuse or reproduction of the artwork and copy in this manual is strictly prohibited without the written consent of Weil McLain.

WARNING

DO NOT USE PETROLEUM-BASED CLEANING OR SEALING COMPOUNDS IN BOILER SYSTEM. SEVERE DAMAGE TO THE BOILER WILL OCCUR.

The following defined terms are used throughout this manual to bring attention to the presence of hazards of various risk levels, or to important information concerning the life of the product.

DANGER

indicates presence of a hazard which *will* cause *severe* personal injury, death or substantial property damage if ignored.

CAUTION

indicates presence of a hazard which *will* or *can* cause minor personal injury or property damage if ignored.

WARNING

indicates presence of a hazard which *can* cause *severe* personal injury, death or substantial property damage if ignored.

NOTICE

indicates special instructions on installations, operation, or maintenance which are important but not related to personal injury hazards.

WARNING

FAILURE TO FOLLOW ALL INSTRUCTIONS IN PROPER ORDER CAN CAUSE PERSONAL INJURY OR DEATH.

Section I: Pre-Installation

CODES

Installations must comply with local codes, laws, regulations and ordinances. Also, Section IV of the ASME Boiler and Pressure Vessel Code, and National Fuel Gas Code ANSI Z223.1-1984 when applicable.

AIR SUPPLY FOR COMBUSTION

WARNING

Provide adequate combustion and ventilation air to assure proper combustion. **DO NOT USE AN EXHAUST FAN IN THE BOILER ROOM.** Incorrect burner operation will result.

SUGGESTED COMBUSTION AIR INLETS

1. For boilers in confined rooms, two permanent openings shall be provided; one within 12 inches from the ceiling and

one within 12 inches from the floor of the room. Each opening shall be at least one square inch per 1,000 BTUH boiler input. These openings shall freely connect with areas having adequate infiltration from outside.

2. When air is provided from outdoors the confined space shall be provided with two openings as outlined above. These openings shall connect directly or by ducts with outdoors or spaces (crawl or attic) that freely connect with the outdoors and shall be of the size listed below for that particular arrangement:

- (a) One square inch per 4,000 BTUH of boiler input for direct outdoor air supply through an outside wall or through vertical ducting directly to outside.
- (b) One square inch per 2,000 BTUH of boiler input for direct outdoor air through horizontal ducting.
- (c) All ducting shall be of the same size as the opening to which it is connected with minimum dimensions of no less than 3 × 3 inches or 9 total square inches of area.

3. Compensate for louver blockage when calculating free air openings. Refer to manufacturer's instructions for size. If unknown, use:

(a) Wood louvers—20-25% free air

(b) Metal louvers or grilles—60-75% free air

Lock open louvers or interlock with equipment to open automatically with boiler operation.

OTHER OPENING SIZES MUST COMPLY WITH LOCAL CODES

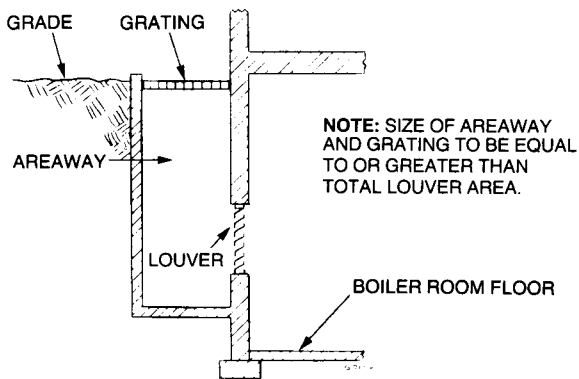

**BOILER ROOM BELOW GRADE
FIGURE 1**

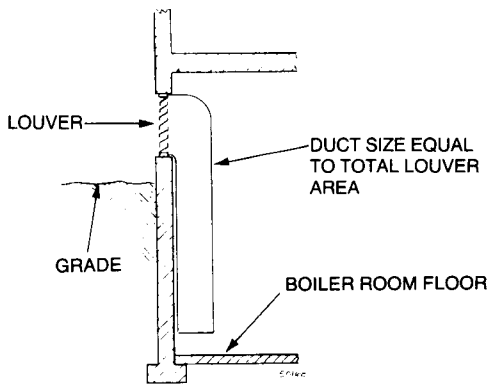

**BOILER ROOM PARTIALLY OR COMPLETELY ABOVE GRADE
FIGURE 2**

CONSIDER ALL CONNECTIONS TO THE BOILER BEFORE SELECTING A LOCATION.

WARNING

To avoid personal injury, death or property damage, keep the boiler area clear and free from combustible materials, gasoline and other flammable vapors and liquids.

MINIMUM CLEARANCES

36 inches—back, for breeching

39 inches—left side, for cleaning and tankless heater removal, if used.

Allow sufficient space on remaining sides for cleaning, servicing and burner installation. (See burner length chart, page 24.)

BOILER FOUNDATION

1. A level concrete or brick foundation is required when:
 - a) There is a possibility of the floor becoming flooded
 - b) Non-level conditions exist

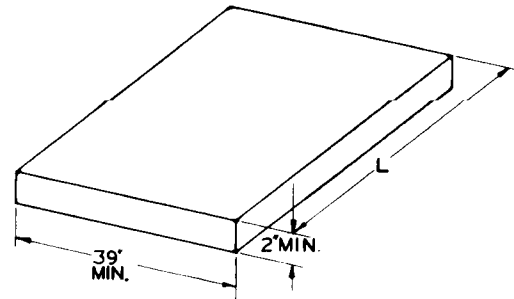

FIGURE 3

BOILER FOUNDATION SIZE—INCHES			
Boiler No.	L Knockdown Boiler	Boiler No.	L Knockdown Boiler
488	33	1288	97
588	41	1388	105
688	49	1488	113
788	57	1588	121
888	65	1688	129
988	73	1788	137
1088	81	1888	145
1188	89		

CHIMNEY OR VENT

88 forced draft boilers operate with overfire positive pressure. Breeching damper must be adjusted during burner start up to .1" W.C. positive pressure.

CAUTION

Avoid long horizontal breechings, excessive numbers of elbows or tees, or other obstructions restricting flow of combustion gases.

See page 23 for minimum breeching diameter. Construct metal vent—select material and thickness in compliance with local codes. Refer to ASHRAE Guide for chimney and breeching calculations.

Two types of vent systems may be used:

FORCED DRAFT

Boiler, breech, and stub vent operate at positive pressure. Entire system must be gas tight to prevent leaks. Stub vent height must be limited to prevent negative draft. (See Figures 4 and 5) Barometric control cannot be installed with stub vent.

BALANCED DRAFT

Boiler operates with positive pressure overfire. Chimney provides negative pressure that must be balanced with a barometric draft control. (See Figures 6 and 7.)

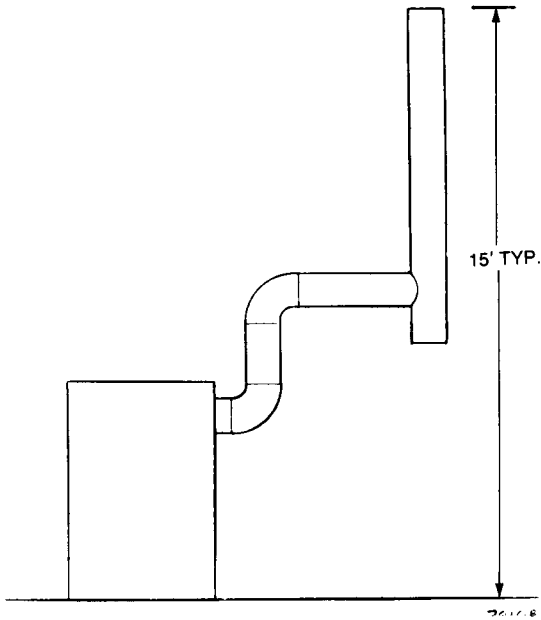

Stub Vent—Forced Draft
Single Boiler
FIGURE 4

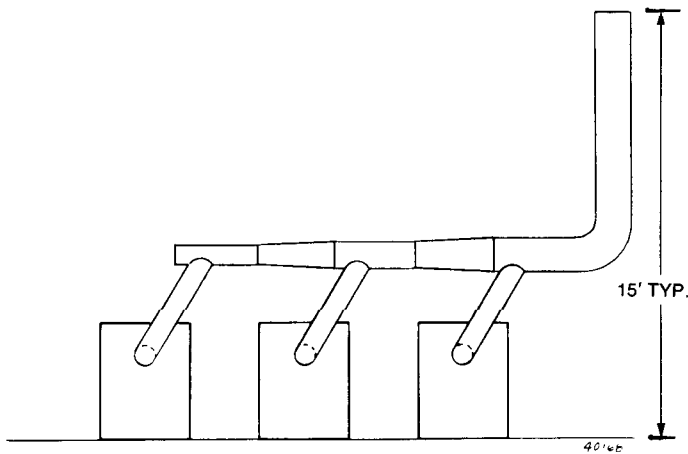

Stub Vent—Forced Draft
Multiple Boiler
FIGURE 5

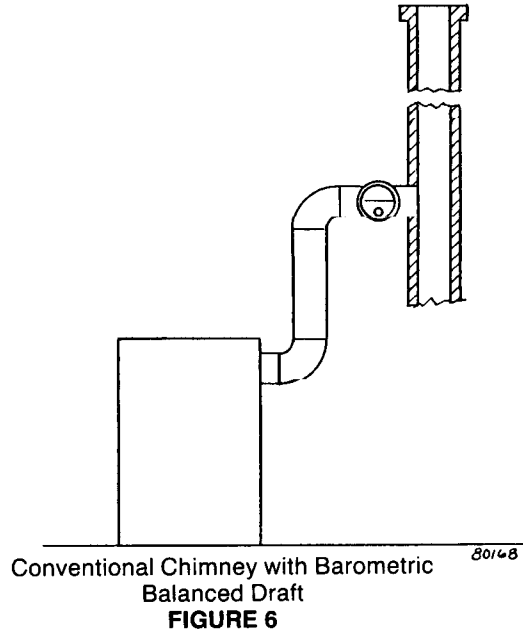

Conventional Chimney with Barometric
Balanced Draft
FIGURE 6

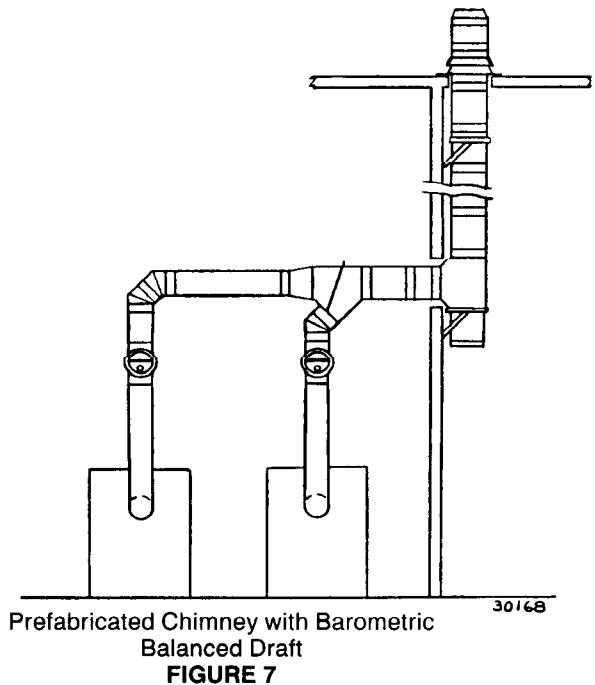

Prefabricated Chimney with Barometric
Balanced Draft
FIGURE 7

Section II: Assembled Sections or Packaged Boilers

1. Remove crate.
2. Remove 4 lag screws (2 front and 2 rear) from shipping rails.
3. Remove boiler from skid:
 - a) Using crane—cable or sling must be capable of safely handling the weight. Use 4 cables or slings per boiler. See Table. Hook ends of slings onto boiler lifting lugs. Hook other ends to eye of crane.
 - b) Using hoist—Raise boiler off skids. Use pipe rollers under steel skid angles to roll boiler.
4. Place boiler in final position. Front angle skids must be flush with front of foundation, if used.
5. Level boiler. Shim under steel skid angles, if necessary.
6. Go to "Hydrostatic Pressure Test," page 9.

LIFTING WEIGHTS AND SLING LENGTHS		
Boiler Number	Approximate Lifting Weight Pounds	*Minimum Sling Length
488	2928	2' 6"
588	3490	3' 0"
688	4152	4' 0"
788	4714	4' 6"
888	5276	5' 0"
988	5838	6' 0"
1088	6400	6' 6"
1100	7062	7' 0"
1288	7624	8' 0"
1388	8186	8' 6"
1488	8748	9' 0"
1588	9310	10' 0"
1688	9872	10' 6"
1788	10,584	11' 0"
1888	11,146	12' 0"

* Minimum sling length from crane hook to boiler lifting lugs.

Section III: Site-Assembly

1. Prepare back section:
 - a) Screw 6" diameter pipe at least 36" long into the 6" return tapping.
 - b) Position section. Block under pipe to hold section upright in **plumb** position.

DANGER

Sections are top heavy and will not stand individually without support.

CAUTION

First section must be **plumb**. Failure to plumb section will cause incomplete sealing of sections.

The pipe and supports can be removed after several sections have been erected.

2. Apply 1/8" continuous bead of sealing rope adhesive in sealing groove around perimeter of section.
3. Place 1/2" rope in groove. Around corner and curve, grasp at 1" intervals and push together. Do not stretch. Cut rope as each section is completed (see Figure 8).

NOTICE

DO NOT PRECUT ROPE. Gas tight seal must be maintained. Start at cleanout opening.

4. Remove any grit from port openings with clean rag.

CAUTION

DO NOT USE any cleaner containing petroleum-based distillate (oil). Elastomer seal failure will occur.

5. Place 9" and 6" elastomer sealing rings in appropriate port openings. See Figure 8.

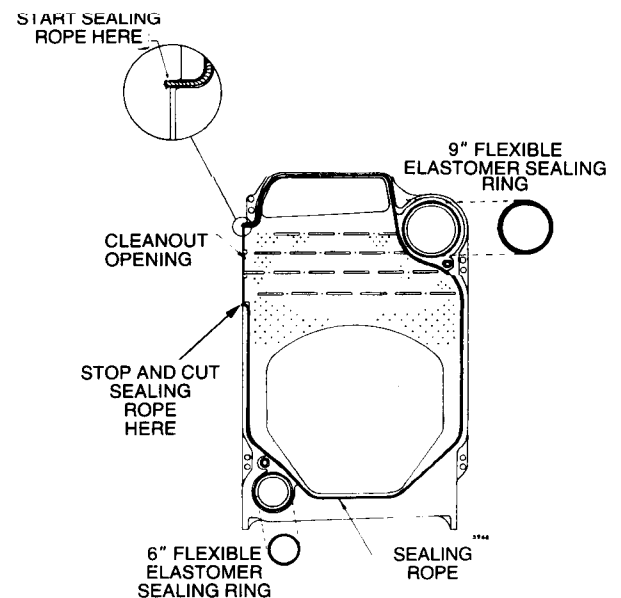

FIGURE 8

6. Apply continuous small bead of silicone sealant around entire **outside** of rings to prevent contact with unburned oil vapors. Refer to Figure 9. **DO NOT APPLY UNDER SEALING RING.**

CAUTION

Contact with unburned oil vapors can cause elastomer seal failure.

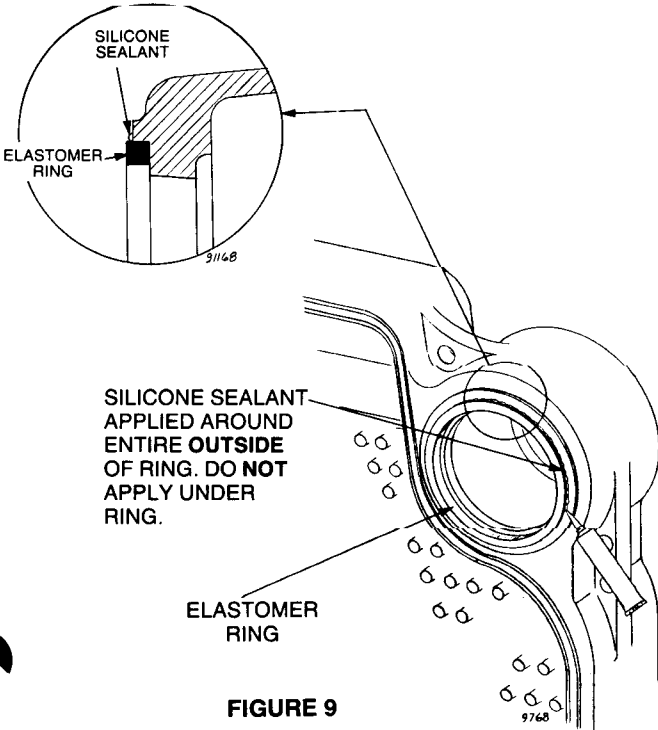

FIGURE 9

7. Prepare intermediate section:
 - a) Discard $\frac{3}{8}$ " diameter shipping tie rods.
 - b) Remove grit from port machined surfaces.

CAUTION

DO NOT USE any cleaner containing petroleum-based distillate (oil). Elastomer seal failure will occur.

- c) Position intermediate sections so aligning lugs fit into sockets of next section. Refer to Figure 10.

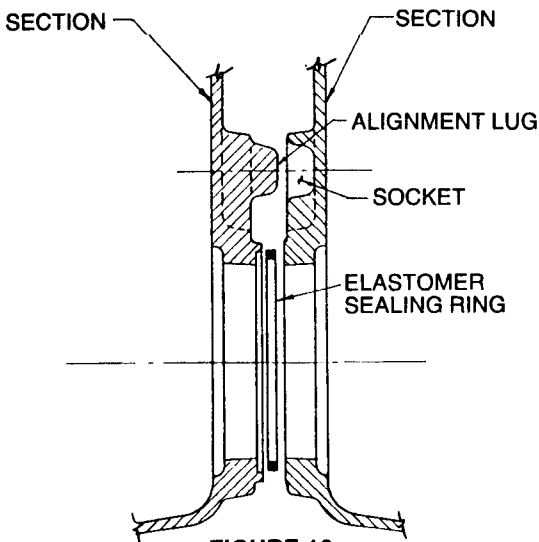

FIGURE 10

8. **DRAW SECTIONS TOGETHER UNTIL METAL-TO-METAL CONTACT IS MADE AROUND MACHINED PORT OPENING (SEE FIGURE 11):**

- a) Oil threads on four draw rods. Install washer and nut on end to be tightened. Use nut only on other end.
- b) Uniformly draw sections together, starting at washer/nut end.
- c) Draw rods should be torqued to a range of 100–120 ft /lbs. Do not back off draw rods.
- d) Metal-to-metal contact will be achieved around port opening. See Figure 11. If a gap does exist, it should be no greater than .032". Check with feeler gauge.
- e) If for any reason gap around port opening **EXCEEDS .032"**, check for rope extending from rope grooves, dirt on port openings or sockets, or misaligned lugs. If corrections are made and gap still exists, contact your Weil-McLain distributor or sales office before continuing installation.

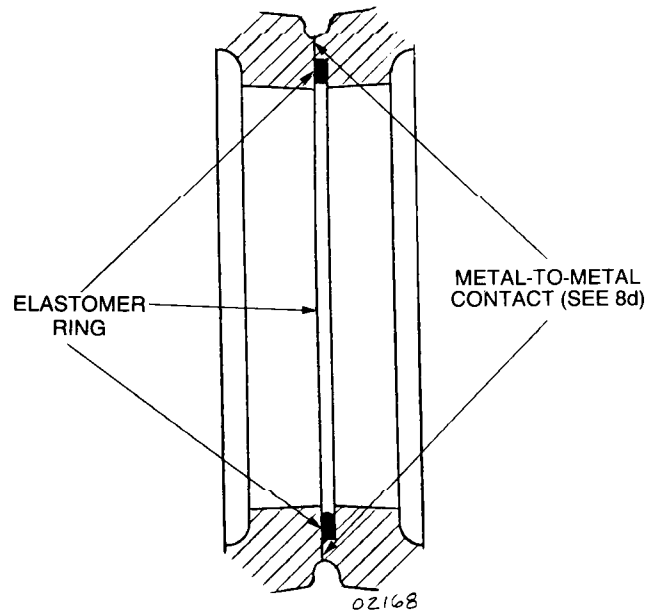

FIGURE 11

9. Prepare drawn section by following steps 2–6.
10. Follow steps 7 through 9 for remaining intermediates and front section:
 - a) Use $\frac{5}{8}$ " \times 11" draw rods between any two intermediate sections.
 - b) "TI" and "SI" sections (if used) **must** be installed in order shown in "Section Arrangements," page 8.

WARNING

Check sealing rope of each section before proceeding to next section. Boiler must be sealed gas-tight.

11. Remove any grit from threads inside tapped holes.

CAUTION

DO NOT USE any cleaner containing petroleum-based distillate (oil). Elastomer seal failure will occur.



12. Install four $\frac{1}{2}$ " \times $3\frac{1}{2}$ " studs to secure burner mounting plate to front section.
 - a) Thread two nuts on rounded end of a stud, locking them together. Thread flat end of stud into one of four holes located around opening in front section.
 - b) Remove nuts from stud.
 - c) Repeat above for remaining three studs.
13. Install burner mounting plate:
 - a) Apply $\frac{1}{8}$ " continuous bead of sealing rope adhesive in groove around burner mounting plate opening on front section.
 - b) Position $\frac{1}{2}$ " sealing rope in groove. Overlap ends at least 1".
 - c) Install burner mounting plate with part number and "UP" positioned at top. Use $\frac{1}{2}$ " washers and nuts.
14. Install front observation port assembly:
 - a) Apply $\frac{1}{8}$ " continuous bead of sealing rope adhesive in groove on front observation port assembly.
 - b) Position $\frac{3}{8}$ " sealing rope in groove. Overlap ends at least 1".
 - c) Secure assembly to section. Use #10-32 \times $\frac{3}{4}$ " truss head screws.
15. Follow step 14 to install back observation port assembly.
16. If using "TI" sections, install tankless or storage water heaters and gaskets or heater cover plates and gaskets. Use $\frac{3}{8}$ " \times $\frac{3}{4}$ " hex head screws.
17. Install clean out plates:
 - a) Place cerafelt blanket insulation piece against cleanout plate.
 - b) Position (2) $\frac{1}{4}$ " \times $1\frac{3}{4}$ " carriage bolts in cleanout opening. Secure with washers and nuts.
 - c) Mount cleanout plate over opening. Secure with nuts.
 - d) Repeat above for remaining cleanout plates.
18. Install draft hood collar:
 - a) Apply $\frac{1}{8}$ " continuous bead of sealing rope adhesive in groove on draft hood collar.
 - b) Position $\frac{1}{2}$ " sealing rope in groove. Overlap ends at least 1".
 - c) Mount collar over flueway outlet on back section. Secure with $\frac{1}{2}$ " \times $1\frac{1}{2}$ " hex head cap screws and washers.

SECTION ARRANGEMENT TABLE WITH INDIRECT WATER HEATERS

BOILER NO.	MAXIMUM NO. OF HEATERS	SECTION ASSEMBLY ALL HEATERS MUST BE ON LEFT SIDE OF BOILER
488W & S	1	RF-TI-I-BA
588W & S	2	RF-TI-I-TI-BA
688W & S	2	RF-TI-I-TI-I-BA
788W & S	3	RF-TI-I-TI-I-TI-BA
888W & S	3	RF-TI-I-TI-I-TI-I-BA
988W & S	4	RF-TI-I-TI-I-TI-I-TI-BA
1088W & S	4	RF-TI-I-TI-I-TI-I-TI-I-BA
1188W & S	5	RF-TI-I-TI-I-TI-I-TI-I-TI-BA
1288W	5	RF-TI-I-TI-I-TI-I-TI-I-TI-I-BA
1288S	4	RF-TI-I-TI-I-SI-I-TI-I-TI-I-BA
1388W	6	RF-TI-I-TI-I-TI-I-TI-I-TI-I-TI-BA
1388S	6	RF-TI-I-TI-I-TI-I-SI-TI-I-TI-I-TI-BA
1488W	6	RF-TI-I-TI-I-TI-I-TI-I-TI-I-TI-I-BA
1488S	5	RF-TI-I-TI-I-TI-I-SI-I-TI-I-TI-I-BA
1588W	7	RF-TI-I-TI-I-TI-I-TI-I-TI-I-TI-I-TI-BA
1588S	7	RF-TI-I-TI-I-TI-I-TI-I-SI-TI-I-TI-I-TI-BA
1688W	7	RF-TI-I-TI-I-TI-I-TI-I-TI-I-TI-I-TI-I-BA
1688S	7	RF-TI-I-TI-I-TI-I-SI-TI-I-TI-I-TI-I-TI-BA
1788W	8	RF-TI-I-TI-I-TI-I-TI-I-TI-I-TI-I-TI-I-TI-BA
1788S	8	RF-TI-I-TI-SI-TI-I-TI-I-TI-SI-TI-I-TI-I-TI-BA
1888W	8	RF-TI-I-TI-I-TI-I-TI-I-TI-I-TI-I-TI-I-TI-I-BA
1888S	8	RF-TI-I-TI-I-SI-I-TI-I-TI-I-SI-I-TI-I-TI-I-BA

RF = Front Section; BA = Back Section; I = Intermediate Section; TI = Intermediate Section with Tankless Heater Opening; SI = Steam Intermediate Section with Top Outlet Tapping; W = Water boiler; S = Steam boiler. "I" sections can be substituted for "TI" sections.
 TANKLESS HEATER LOCATIONS—Heater knockouts in jacket panel for first two TI sections only (counting from the front). Other tankless heater openings must be cut.

Section IV: Hydrostatic Pressure Test

1. Refer to Control Tapping Table and Figure 12. Install:
 - a) Boiler drain (not supplied).
 - b) Water pressure gauge—for test only.
 - c) Air vent in upper tapping.
2. Plug remaining tappings.
3. Fill boiler. Vent all air. Test at 1½ times working pressure for more than 10 minutes.

WARNING

DO NOT LEAVE BOILER UNATTENDED. Cold water fill could expand and cause excess pressure.

4. Check for maintained gauge pressure.
5. Check for leaks. Repair if found.

CAUTION

Repair leaks at once. Damage to boiler can result. NEVER use petroleum-based stop leak compounds. Leakage between sections will occur.

6. Drain boiler and remove plugs from tappings used for controls and accessories.

CONTROL TAPPING TABLE

LOCATION	SIZE	STEAM	WATER
A	2"	Steam Relief Valve and/or Skim Tapping	High Limit Manual Reset Limit
B	2"	Steam Relief Valve	Water Relief Valve
C ₁ & C ₂	1"	Low Water Cut-offs	Alternate Low Water Cut-offs
C ₁		—	Combination High & Low Limit Control
D ₁ & D ₂	1"	Alternate Low Water Cut-offs	Firing Rate Temperature Control (When Used) Low Water Cut-offs
E ₁ & E ₂	1/2"	Gauge Glass	—
F ₁ & F ₂	3/8"	Try Cock Tappings	—
G	3/4"	Pressure Limit Control, Pressure Operating Control and Pressure Gauge Firing Rate Pressure Control (When Used)	Combination Pressure-Temperature Gauge
H	3/4"	Boiler Drain*	Boiler Drain
K	1"	—	Piping to Compression Tank or Automatic Air Vent

*See page 10 for system blow-off (drain) valve location and size.

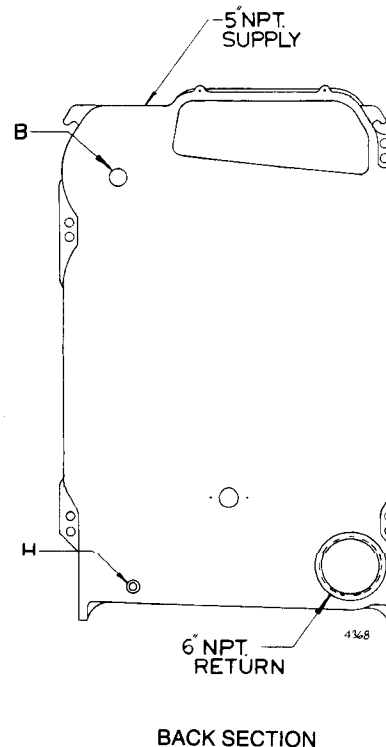
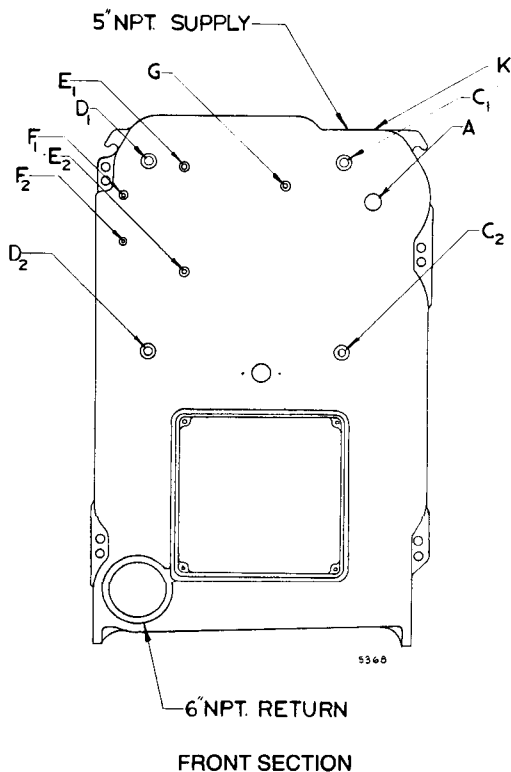

FIGURE 12

WATER BOILERS

1. It is recommended that system supply and return piping be installed and piping connections be attached to the boiler before erecting jacket or installing controls.
2. Improper piping systems and/or undersized piping can contribute to erratic boiler operation and possible boiler damage. Install as shown below.

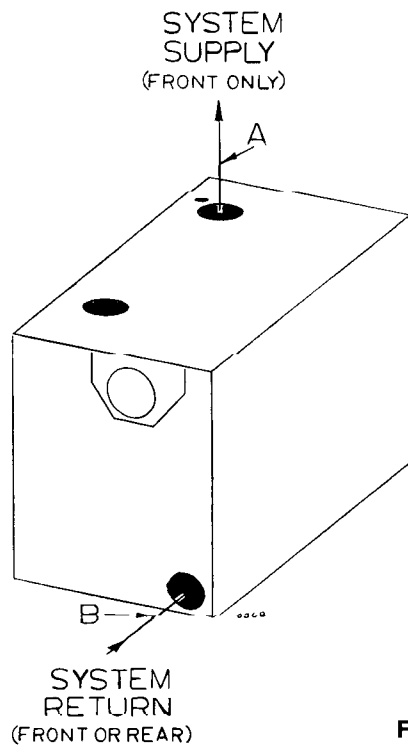

FIGURE 13

3. Reverse water flow through boiler must not be used.
4. Connect supply and return piping:
 - a) Size according to Tables 1 or 2.

TABLE 1
PIPE SIZES FOR KNOWN FLOW RATES*

WATER FLOW RATE GPM	SUPPLY PIPE SIZE A	RETURN PIPE SIZE B
To 35 GPM	2"	2"
36 to 50 GPM	2½"	2½"
51 to 77 GPM	3"	3"
78 to 142 GPM	4"	4"
143 to 237 GPM	5"	5"
238 to 404 GPM	6"‡	6"

* High temperature rise through boiler is permissible when boiler piping connections are sized using above Table 1. INTERMITTENT flow at HIGH velocities may damage any boiler.

‡ Requires nipple and 5" x 6" reducing coupling which is provided with 1288 through 1888 boilers only. The total pressure drop through the 1888 boiler using the nipple and reducing coupling will not exceed ¼ PSI. For smaller boilers the pressure drop will be less.

TABLE 2
PIPE SIZES FOR UNKNOWN FLOW RATES**

BOILER NUMBER	SUPPLY PIPE SIZE A	RETURN PIPE SIZE B
488	3"	3"
588 to 788	4"	4"
888 to 1188	5"	5"
1288 to 1888	6"‡	6"

** All piping sizes are based upon 20° F. temperature rise through the boiler. For use of other temperature rises through the boiler (i.e. higher flow rates) determine the flow rate and use Table 1 for pipe sizes.

‡ Requires nipple and 5" x 6" reducing coupling which is provided with 1288 through 1888 boilers only. The total pressure drop through the 1888 boiler using the nipple and reducing coupling will not exceed ¼ PSI. For smaller boilers the pressure drop will be less.

- b) Connect circulator to system supply piping to pump water away from boiler.
- c) For return piping, use full diameter pipe for 10 times that diameter before making any reduction. For example, a 4" return should not be reduced any closer to boiler return tapping than 40".
- d) Install system blow-off (drain) valve in lowest part of return piping close to boiler. Size per ASME chart below.

MINIMUM BLOW OFF (DRAIN) VALVE SIZE

Boiler Size	Valve Size (in.)
488-588	1
688-1088	1¼
1188-1888	1½

5. When three-way valves are used for temperature modulation, install slow-opening valves to minimize the potential of boiler thermal shock.
6. Multiple boilers, see Figure 15.
7. a) Closed type expansion tank—Connect to 1" tapping "K" (refer to tapping table—page 9). Use 1" N.P.T. piping. Any horizontal piping must pitch upward toward tank at least 1 inch for each 5 feet of piping.
 - b) Closed diaphragm pre-pressurized type expansion tank—locate anywhere in system, preferably near boiler.

NOTICE

Automatic air vent must be installed in "K" tapping when a closed diaphragm pre-pressurized tank is used.

c) Connect cold water fill to expansion tank piping. See Figure 14. Also shown are recommended valves and

water meter. Water meter will detect need for make-up water, indicating leaks in system.

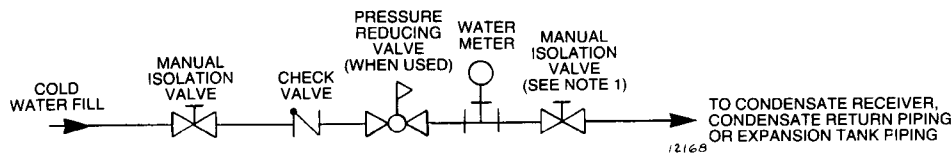

NOTE: 1. Use globe valve when manual adjustment of water flow is required.

**MAKE-UP WATER PIPING
STEAM OR WATER BOILERS
FIGURE 14**

PRIMARY-SECONDARY PIPING

Weil-McLain recommends piping as shown. For single boilers, pipe as shown for one unit.

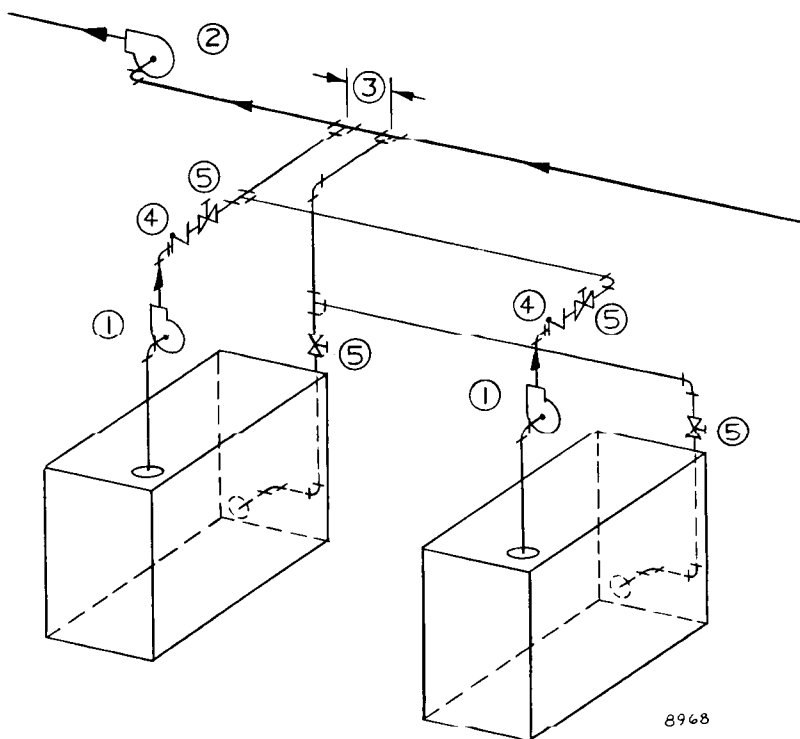

FIGURE 15

- ① Size secondary boiler pump GPM based upon following formulas:

$$\frac{230^{\circ}\text{F} - \text{RETURN WATER TEMPERATURE}}{\text{TEMPERATURE RISE THRU BOILER}} = \text{GPM}$$

$$\frac{\text{GROSS OUTPUT IN BTU/HR.}}{\text{TEMP. RISE IN } ^{\circ}\text{F} \times 500} = \text{GPM}$$

Calculate only secondary piping circuit resistance. Boiler resistance will be approx. equal to three 90° elbows of secondary pipe size.

Operate each boiler and its secondary pump from EMCS system. Do not maintain boiler at predetermined water temperature.

- ② Primary pump GPM and head calculation should not include secondary boiler circuits. Primary pump can operate continuously during heating season.
- ③ Space 12" maximum or as close as practical.
- ④ Swing check valve.
- ⑤ Hand valve.

Expansion tank(s), relief valves and other accessories are required but not shown.

STEAM BOILERS

1. Improper piping systems and/or undersized piping can contribute to erratic boiler operation and possible boiler damage. The piping system must be installed as illustrated using pipe sizes shown. Consult Weil-McLain Distributor or Sales Office before installing alternate piping.
2. A Hartford Loop piping arrangement and wet return are required.
3. Maintain 24" minimum from waterline to header.
4. Receiver with float switch energizing feed pump is not recommended.
5. Install system blow off valve in lowest part of return piping close to boiler. Size to ASME code requirements. See table on page 10.
6. Install cold water fill piping as shown in Figure 14. Also shown are recommended valves and water meter. Water meter will detect need for make-up water, indicating leaks in system.

STEAM BOILER PIPE SIZES

Fig. No.	Boiler Size	Riser Pipe Size				Header* H	Equalizer J
		A	B	C	D		
16	488	4"				4"	2 1/2"
16	588 and 688	5"				5"	2 1/2"
17	788	4"	4"			6"	2 1/2"
17	888	5"	5"			6"	2 1/2"
17	988-1088	5"	5"			8"	2 1/2"
17	1188	5"	5"			8"	4"
18	1288-1488	5"	5"	5"		8"	4"
18	1588-1688	5"	5"	5"		10"	4"
19	1788-1888	5"	5"	5"	5"	10"	4"

*24" Minimum from waterline to header.

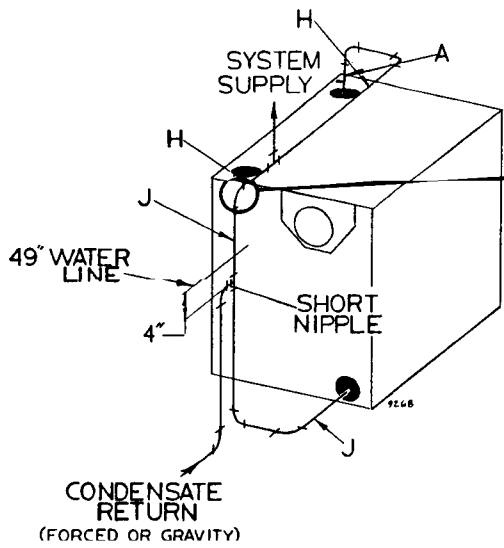

24" minimum from waterline to header
488 THROUGH 688
STEAM BOILER PIPING
FIGURE 16

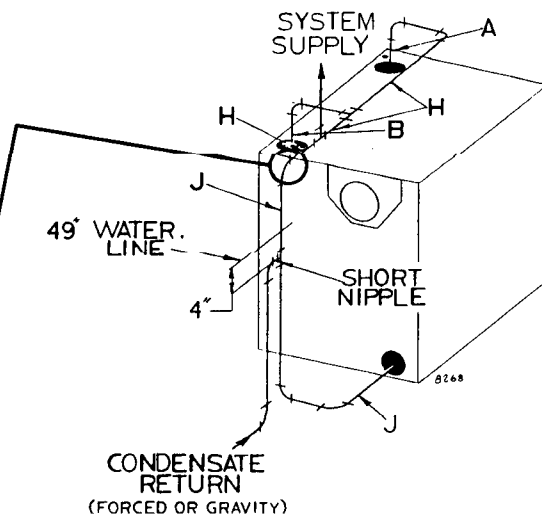

24" minimum from waterline to header
788 THROUGH 1188
STEAM BOILER PIPING
FIGURE 17

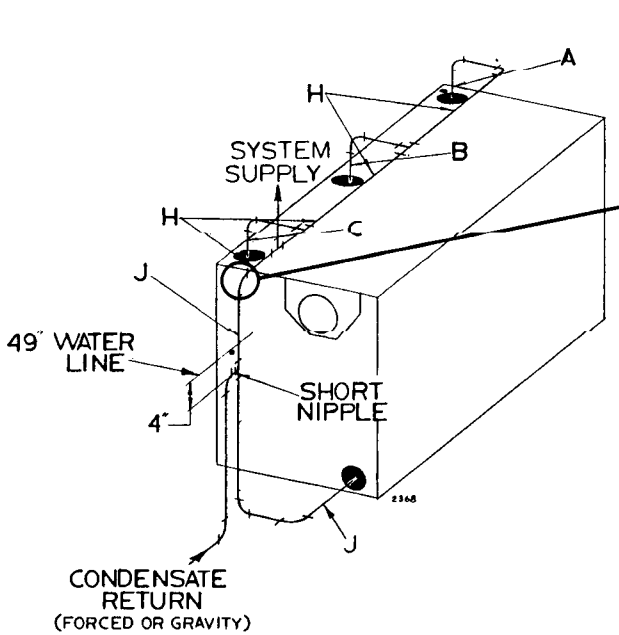
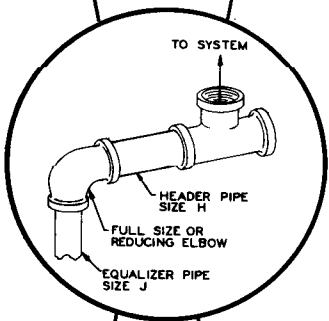

24" minimum from waterline to header
1288 THROUGH 1688
STEAM BOILER PIPING
FIGURE 18

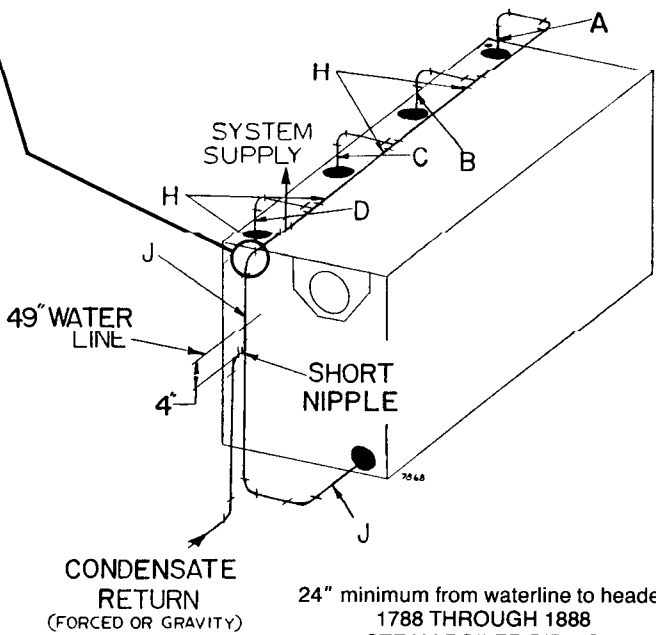

24" minimum from waterline to header
1788 THROUGH 1888
STEAM BOILER PIPING
FIGURE 19

NOTICE

Satisfactory operation of any steam heating system depends upon adequate return of condensate to maintain steady water level. Avoid adding excessive amounts of raw make-up water. Where condensate return is not adequate, a low water cut-off

and pump control, condensate receiver, and condensate boiler feed pump should be installed. Refer to Figure 20 for piping, Figure 21 for sizing.

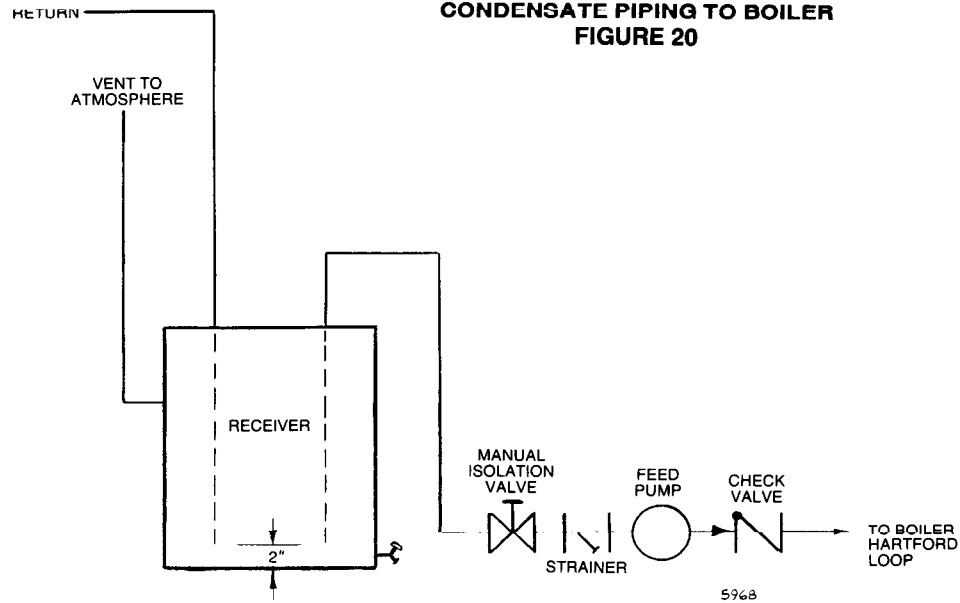

CONDENSATE RECEIVER CAPACITY

Boiler Model	I = B = R Output # Steam Per Hour	Gallons Condensate Per Hour	Minimum Condensate Receiver Capacity (Gal.)				Recommended Condensate Feed Pump Capacity GPM at 15 PSI
			15 Minute Boiler Operation	30 Minute Boiler Operation	45 Minute Boiler Operation	60 Minute Boiler Operation	
488	810	97	29	58	87	116	3.2
488 R	794	95	28	57	85	114	3.1
588	1,084	130	39	78	117	156	4.3
688	1,358	163	49	98	147	196	5.4
788	1,632	195	59	117	176	234	6.5
888	1,904	228	68	137	205	273	7.6
988	2,170	261	78	157	235	313	8.7
988R	1,991	239	72	145	217	289	8.0
1088	2,452	294	88	176	265	353	9.8
1088R	2,304	277	83	166	249	332	9.2
1188	2,724	327	98	196	294	392	10.9
1288	3,000	360	108	216	324	432	12.0
1388	3,270	392	117	235	353	470	13.1
1488	3,550	426	127	255	383	511	14.2
1588	3,820	458	137	274	412	550	15.3
1688	4,090	490	147	294	441	588	16.4
1688R	3,980	478	143	287	430	574	15.9
1788	4,370	524	157	314	471	629	17.5
1888	4,640	557	167	334	501	668	18.6

FIGURE 21

**MULTIPLE STEAM BOILER PIPING
(WITH FORCED CONDENSATE RETURN)**

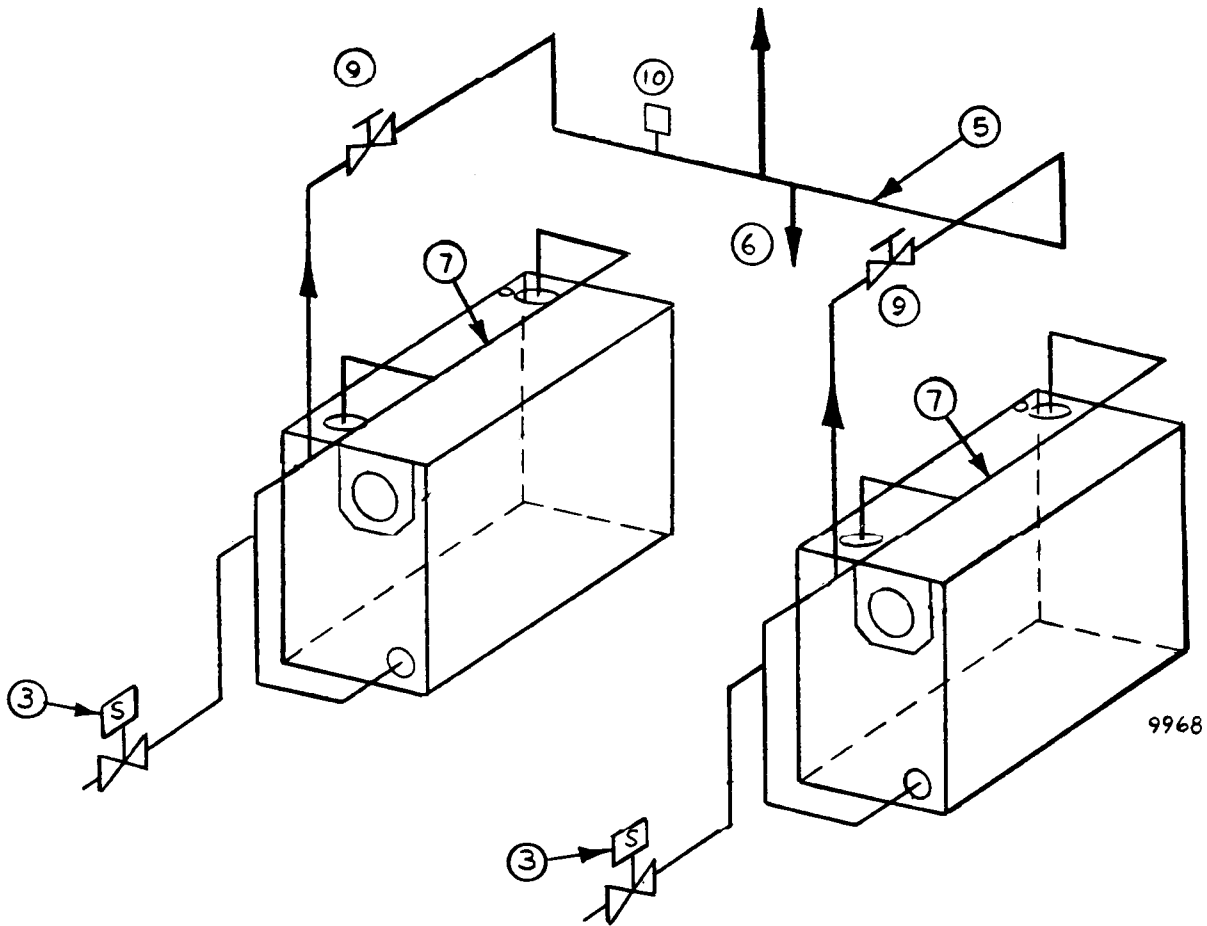

FIGURE 22

1. Install boiler feed pump control on each boiler with body mark at level indicated in boiler manual.
2. Use separate feed pumps for each boiler, or . . .
- ③ Use single feed pump and separate solenoid valves for each boiler.
4. Install a combination float and thermostatic trap on each boiler to prevent flooding of one boiler while other boiler is firing. For 88 boiler, install trap in skim tapping A (see page 9). Connect traps to condensate receiver.
- ⑤ Construct common supply drop header with pipe size at least same size as largest boiler header size.
- ⑥ Install drain line at center of common supply drop header. Use a combination float and thermostatic trap to drain to condensate receiver.
- ⑦ Install boiler pipe as shown in boiler manual.
8. Use EMCS system with header mounted pressure control(s) to sequence boilers.
- ⑨ Install stop valves per ASME code requirements and automatic steam valves when used. Use EMCS system to open automatic steam valve before firing burner.
- ⑩ Steam pressure control.

Section VI: Jacket and Heaters

JACKET INSTALLATION

Refer to 88 Jacket Erecting Instructions packed in jacket carton. Boiler must be hydrostatically pressure tested, plugs for all unused tappings must be installed, supply and return piping attached, and cleanout plates must be in position before jacket is installed.

STORAGE HEATER HOOK-UP (when used)

1. Locate storage tank as high as possible above boiler.
2. Vertical type storage tank can be used if bottom of tank can be located above top of boiler.
3. To provide gravity circulation:
 - a) Horizontal supply from heater to tank must pitch upward 1 inch for each 10 feet of piping.
 - b) Horizontal return from tank to heater must pitch downward 1 inch for each 10 feet of piping.
4. Locate tank return piping above heater inlet.
5. Use as few elbows and pipe fittings as possible.
6. Multiple storage heaters—pipe as shown in Figure 24.
7. In hard water areas, it is advisable to soften cold domestic supply water to heaters to prevent lime build-up.

STORAGE HEATER RATINGS*

Heater Number	180	212	Inlet and Outlet Tappings
	Heater Capacity Gallons 40°—140°F Rise	Heater Capacity Gallons 40°—140°F Rise	
816	140 in 3 Hrs.	205 in 3 Hrs.	1"
Recommended Storage Tank	200-500 Gallons	250-500 Gallons	

*Weil-McLain Ratings

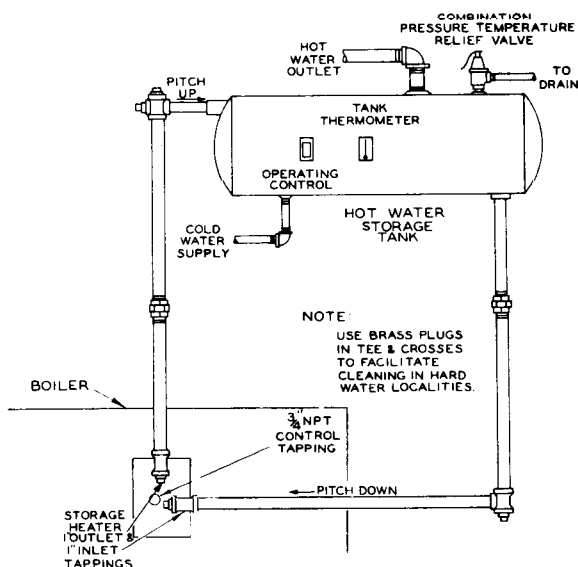

**STORAGE HEATER PIPING
FIGURE 23**

TANKLESS HEATER HOOK-UP (when used)

1. Size piping no smaller than the heater inlet and outlet.
2. Automatic mixing valve must be installed. See Figure 24. Follow manufacturer's instructions to install.
3. Flow regulating valve must be installed. Size according to intermittent draw of heater as shown in following table.
4. Operating control with a small adjustable differential scale is recommended. Install in temperature control tapping in heater plate.
5. Multiple tankless heaters (see Figure 24):
 - a) Use a cold water supply header with individual risers to each heater.
 - b) Hot water outlets must also be headered.
 - c) Do not pipe multiple heaters in series.
 - d) Header size, increase one pipe size for each additional heater.
6. In hard water areas, it is advisable to soften cold domestic supply water to heaters to prevent lime build-up.

DOMESTIC WATER HEATER CAPACITIES TANKLESS HEATER RATINGS*

Heater Number	**Intermittent Draw GPM 100°F Average Temperature Rise	***Continuous Draw GPM 100°F Temperature Rise	Inlet and Outlet Tappings
820	8.5 G.P.M.	8.0 G.P.M.	3/4"

**Gallons of Water per min. heated from 40° to 140°F with 200°F boiler water temp.
***Continuous Draw—no recovery period.

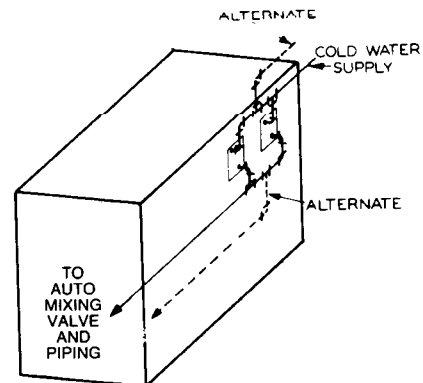

**MULTIPLE TANKLESS HEATERS
FIGURE 24**

Section VII: Installing Boiler Controls

WATER BOILER CONTROLS

WARNING

Failure to properly install, pipe and wire boiler controls may result in severe damage to boiler, building and personnel, and is not covered by boiler warranty.

1. Install furnished controls where shown below.
2. Relief valve must be mounted vertically.

WARNING

Relief valve discharge piping must be piped near floor close to floor drain to eliminate potential of severe burns. Do not pipe to any area where freezing could occur.

3. **Low water cut off for water boilers:**
 - a) Must be installed on any water boiler if the boiler is located above radiation level.
 - b) May be required on water boilers by certain state, local or territorial codes or insurance companies.

If a low water cut-off is used on a water boiler, use a control designed especially for water installations. See control tapping table for location.

4. Dual limit control settings:
 - a) low—set according to design requirements.
 - b) high—at least 20° higher than low limit, 240° F. maximum.
5. Install optional controls per control manufacturer's instructions.

CONTROL TAPPING TABLE

LOCATION	SIZE	STEAM	WATER
A	2"	Steam Relief Valve and/or Skim Tapping	High Limit Manual Reset Limit
B	2"	Steam Relief Valve	Water Relief Valve
C ₁ & C ₂	1"	Low Water Cut-offs	Alternate Low Water Cut-offs
C ₁		—	Combination High & Low Limit Control
D ₁ & D ₂	1"	Alternate Low Water Cut-offs	Firing Rate Temperature Control (When Used) Low Water Cut-offs
E ₁ & E ₂	1/2"	Gauge Glass	—
F ₁ & F ₂	3/8"	Try Cock Tappings	—
G	3/4"	Pressure Limit Control, Pressure Operating Control and Pressure Gauge Firing Rate Pressure Control (When Used)	Combination Pressure-Temperature Gauge
H	3/4"	Boiler Drain*	Boiler Drain
K	1"	—	Piping to Compression Tank or Automatic Air Vent

* See page 10 for system blow-off (drain) valve location and size.

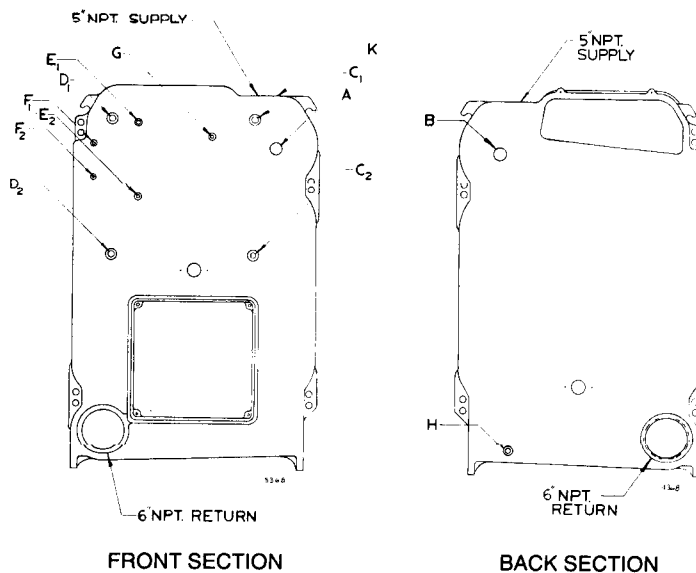

FIGURE 25

STEAM BOILER CONTROLS

WARNING

Failure to properly install, pipe and wire boiler controls may result in severe damage to the boiler, building and personnel, and is not covered by boiler warranty.

1. Install furnished controls where shown in Control Tapping Table and Figure 25.
2. Relief valve must be mounted vertically.

WARNING

Pipe relief valve discharge through vertical piping to atmosphere. Install drain pan elbow to drain condensate. Pipe near floor close to floor drain.

Recommended Locations For Low Water Cutoff, Water Feeders and Pump Controllers When Used on Weil-McLain Steam Boilers.*

LOCATION NO. 1		LOCATION NO. 2	
Primary Water Level Control *	Casting Line Height Above Bottom of Gauge Glass(A)	First Back-Up Water Control *	Casting Line Height Above Bottom of Gauge Glass(B)
150	2 ³ / ₈ "	—	—
61, 63	1/4"	—	—
93, 193 & 94	2"	—	—
51-2 & 51-S-2	1" to 1 ¹ / ₄ "	—	—
61 & 63	1/2"	61 & 63	1/4"
93, 193 & 94	2"	93†, 193† & 94†	1/4"
150	2 ³ / ₈ "	150	1/4"
93, 193 & 94	2"	61 & 63	1/4"
150	2 ³ / ₈ "	61 & 63	1/4"
93, 193 & 94	2"	—	—
93, 193 & 94	2"	51-2 & 51-S-2	1/4"
150	2 ³ / ₈ "	—	—
150	2 ³ / ₈ "	51-2 & 51-S-2	1/4"

* Other manufacturers controls providing similar function may be used provided they are properly located and are selected to handle the boiler evaporative capacity.

† Use low water cutoff function only; pump controller function should only be used on "higher" control location.

3. Install water level controls in tappings as shown in Figure 26.
 - a) Install optional controls according to Control Tapping Table and Figure 26 using fittings (not furnished).
 - b) If water level control to be used is not dimensionally diagrammed in Figure 26, locate cast-on-body mark on control, install according to manufacturer's instructions.
4. Install steam pressure operating and high limit controls and pressure gauge. See Figures 27a and 27b.
5. Pressure limit control settings:
 - a) low—per design requirements.
 - b) high—at least 2 PSIG higher than low limit, 15 PSIG maximum.

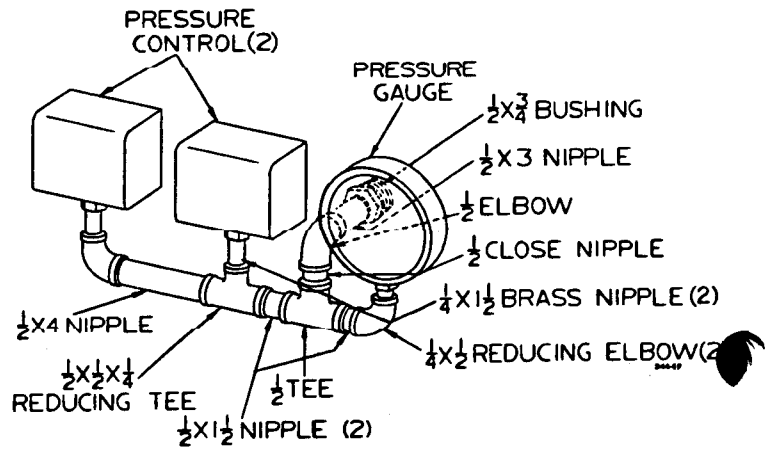

NOTE: Check local codes for manifold size and cleanout requirements.

CONTROL SYPHON AND FITTINGS
FIGURE 27a

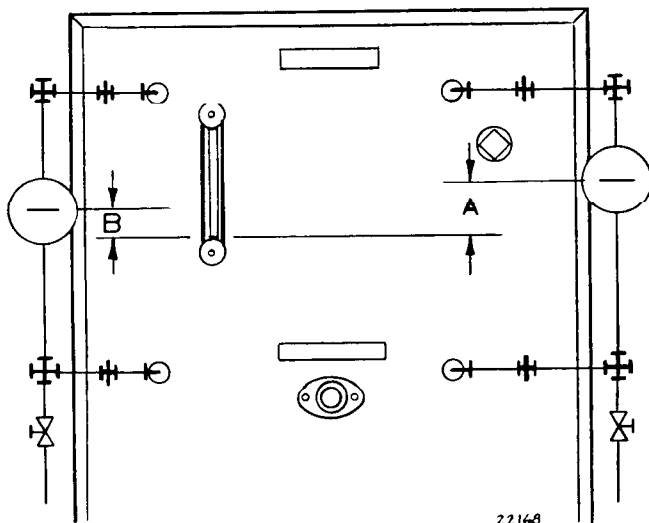
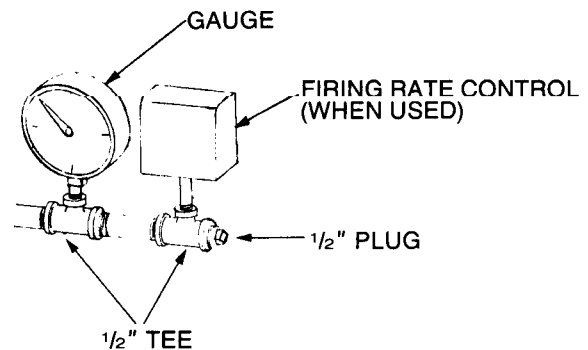

FIGURE 26



FIRING RATE CONTROL PIPING
FIGURE 27b

Section VIII: Burner Installation

1. Unpack burner.
2. Place gasket around air tube and against burner mounting flange. If sealing rope is used, apply $\frac{1}{8}$ " continuous bead of rope adhesive around burner mounting flange and apply sealing rope to make gas-tight seal.
3. Mount burner into opening in burner mounting plate.

CAUTION

Maintain gas-tight seal between burner mounting flange and plate to prevent damage to air tube.

5. Level burner, using burner support brackets where required.
6. Secure with furnished bolts.
7. Retain burner information packet. Keep with boiler.

Section IX: Wiring

WARNING

Electric shock hazard. Can cause severe injury or death. Disconnect power source before installing or servicing.

All wiring should be installed in compliance with the rules of the National Electrical Code ANSI/NFPA No. 70-1984 for installation in the U.S.A. or Canadian Electrical Code C22.2 Part 1 for Canadian installations, and any local, state, or insurance requirements or codes having jurisdiction.

1. Wiring diagram is found in burner information packet.

2. Follow burner manual and wiring diagram for proper wiring of burner and boiler controls.
3. Use 14 gauge wire for:
 - a) operating wiring
 - b) safety circuit wiring
4. Where burner motor voltage differs from control voltage, supply proper voltage to each.
5. Use properly sized fused disconnect and conductors for control circuit and burner motor.

Section X: Fuel Line Piping

GAS PIPING

In sizing the gas piping, the following factors should be considered.

- a) Diameter and length of the gas supply piping.
 - b) Number of fittings.
 - c) Maximum gas consumption (including any possible future expansion).
 - d) Allowable loss in gas pressure from the gas meter outlet to the boiler.
1. Minimum inlet natural gas pressure required at manual main shut-off gas valve—see Burner Installation and Service Manual and material list.
 2. Follow good piping practices.
 3. Pipe joint compound (pipe dope) must be resistant to the corrosive action of liquified petroleum gases and applied sparingly only to the male threads of pipe joints.
 4. A drip leg must be installed at inlet of gas connection to boiler. Where local utility requires drip leg be extended to the floor, use an appropriate length of pipe between the cap and tee.
 5. A ground joint union must be installed in the piping to provide for servicing (see Figure 28).

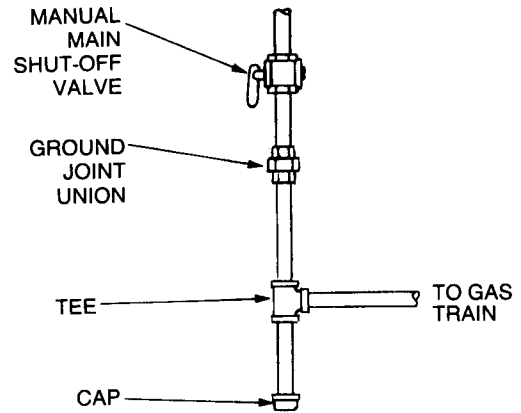

**GAS SUPPLY PIPING
FIGURE 28**

6. Piping must be supported by hangers, not by the burner or its accessories.
7. Purge all air from the supply piping.
8. All gas piping should be tested for leaks after installation—BUBBLE TEST.

FUEL OIL PIPING

DANGER

To prevent oil flow in case of oil line breakage:

- a) Use anti-syphon device when any part of tank is above burner level
- b) Use check valve in suction line on burner side of manual shut-off valve nearest tank when top of fuel tank is below burner level.

1. Two-pipe fuel oil piping system is required for all installations.
2. Supply and return lines must enter tank from top, extending to within 4–6" from bottom of tank.
3. Use oil filter sized for suction line capacity.

CAUTION

Do not install filter close to outside wall or outside.

5. Use continuous copper tubing to reduce possible piping leaks and sealing when piping is buried.
6. Use flare type fittings, not compression type.

DANGER

Fire hazard. **DO NOT USE** soldered fittings. No safe repair can be made.

7. Follow good piping practices.
8. Pipe joint compound (pipe dope) must be resistant to corrosive action of fuel oil. Apply sparingly only to male threads of pipe joints.
9. Supply and return piping should be sized to design conditions, but not less than 1/2" O.D. continuous copper tubing.
10. Auxiliary fuel oil pump is recommended when suction line exceeds 12 feet of lift.
11. Install swing joints to tighten as buried tank settles to prevent fuel line breakage.
12. Where iron pipe is required by local codes, make swing joints with nipples and elbows several inches long on both suction and return lines. Locate close to tank.
13. Install manual shut-off valve in suction line piping near burner and where piping enters building from outside tank.
14. Pitch suction line piping toward fuel tank.
15. Provide tee and plug at highest point in suction line to release air from suction line and aid in priming.

Section XI: Final Adjustments

FILLING WATER BOILERS

1. Close manual air vents and drain cocks.
2. Fill to correct system pressure. Correct pressure will vary with each application.
3. a) Starting on the lowest floor, open air vents one at a time until water squirts out. Close vent.
b) Repeat with remaining vents.
4. Refill boiler to correct pressure.

FILLING STEAM BOILERS

1. Do not fill (except for leakage tests) until boiler is ready to be fired.
2. Fill to normal waterline, halfway up gauge glass.
3. Boiler water pH 7.0 to 8.5 is recommended.
4. Make burner breeching and damper adjustment, then follow skimming procedure for all newly installed steam boilers.

BURNER AND BREECHING DAMPER ADJUSTMENT (See Figure 29)

CAUTION

Final burner adjustments must be made using combustion test equipment to assure proper operation. **DO NOT FIRE BOILER WITHOUT WATER OR SECTIONS WILL OVERHEAT.**

1. Lock open breeching damper.
2. Refer to burner manual for start-up and service.
3. Let burner advance to high fire. Heat boiler to design conditions.
4. Using combustion test equipment, adjust burner for:
 - a) 12% (+1/4%) CO₂ for No. 2 fuel oil, 0 smoke
 - b) 9-10% CO₂ natural gas, CO in flue gas not to exceed 300 ppm (0.03%).
5. Adjust breeching damper to assure 0.1" W.C. positive pressure at test opening on draft hood collar.
6. Secure damper.
7. Plug test opening with 1/8" brass plug.
8. Adjust barometric draft control to design conditions, when used.
9. Recheck following step #4 above. Readjust as necessary.

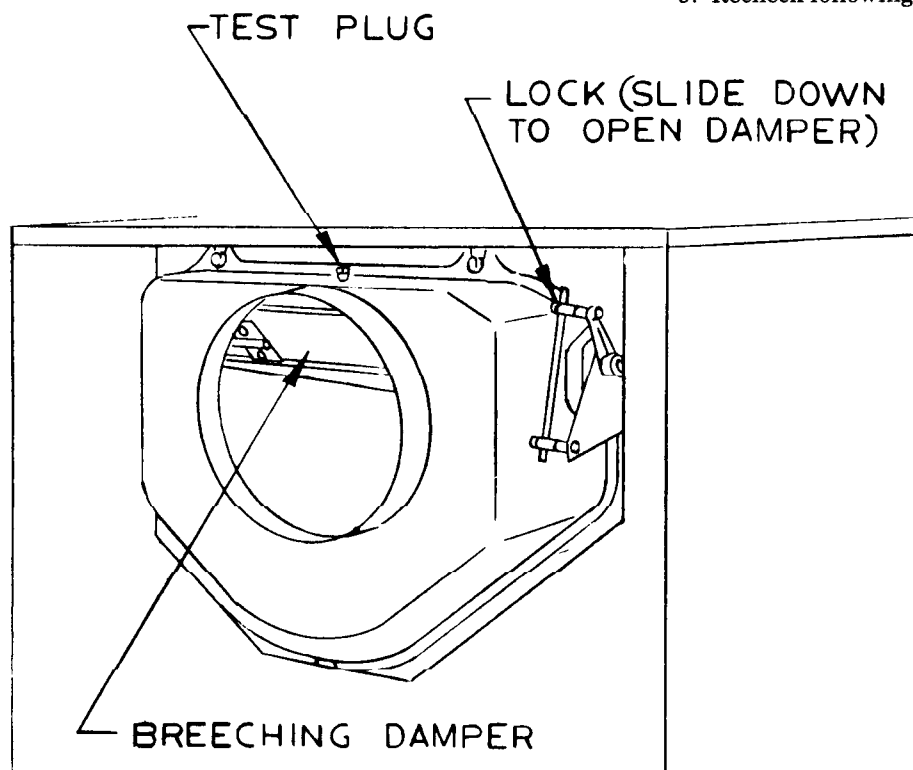

**BREECHING DAMPER
FIGURE 29**

90168

SKIMMING STEAM BOILERS

CAUTION

Clean all newly installed steam boilers to remove oil. Failure to properly clean can result in violent fluctuations of water level, water passing into steam mains, or high maintenance costs on strainers, traps and vents. Do not use PETROLEUM based products in this boiler!

NOTICE

Skim boiler only. DO NOT clean old piping. Leaks can occur.

1. Provide 2" piping from boiler skim tapping to floor drain.
2. Adjust waterline to midpoint of skim piping.
3. Fire burner to maintain a temperature below steaming rate during skimming process.
4. Feed in water to maintain water level. Cycle burner to prevent rise in steam pressure.
5. Continue skimming until discharge is clear. This may take several hours.
6. Drain boiler. While boiler is warm but NOT HOT, flush all interior surfaces under full pressure until drain water runs clear.
7. Remove skim piping. Plug skim tapping.
8. Close drain cock. Fill with fresh water to waterline. Start burner and steam for 15 minutes to remove dissolved gases. Stop burner.
9. Check traps and air vents for proper operation.

WATER TREATMENT

Never use petroleum based stop-leak compounds. Water seal deterioration will occur, resulting in leakage between sections.

Continual make-up water will reduce boiler life. Minerals can build up in the sections, reducing heat transfer, overheating the cast iron, and causing section failure.

For unusually hard water areas or low pH conditions (less than 7.0) consult local water treatment company.

Freeze protection (when used):

Use antifreeze especially made for hydronic systems. Inhibited propylene glycol is recommended. DO NOT use undiluted or automotive type antifreeze.

50% solution provides maximum protection to about -30°F.

Local codes may require a back-flow preventer or actual disconnect from city water supply.

Determine quantity according to system water content. Boiler water content is listed on page 23. Percent solution will affect sizing of heat distributing units, circulator and expansion tank.

Follow antifreeze manufacturer's instructions.

CHECKING GAS-TIGHT SEAL

WARNING

BOILER MUST BE SEALED GAS TIGHT for proper combustion efficiency and safety to building occupants!

1. Remove jacket side and top panels.
2. Shut off breeching damper.
3. Start burner. Observe all sealing points and chalk mark any not gas-tight.
4. Use silicone sealant to seal marked areas.
5. Replace jacket panels.



Built to
ASME
Specifications

Ratings

Boiler No.	△ I-B-R Burner Capacity			Gross I-B-R Output MBH †	Net I-B-R Ratings ‡			*** Net Sq. Ft. Water	Boiler H.P.	Net Firebox Volume Cu. Ft.	**** Stack Gas Volume CFM	□ Positive Press. In Firebox	I-B-R Vent Dia. Inches	Water Boiler Content (Gals.)	Packaged Boiler Weight Pounds
	** Light Oil G.P.H.	○ Gas MBH	Min. Gas Pres. Req'd. In. W.C.		Steam Sq. Ft.	Steam MBH	Water MBH								
▲ 488°F•	7.0	1,010		810	2,533	608	704	4,694	24.2	11.02	376	.43	10	109	2830
▲ 488 R°F•	6.9	996		794	2,483	596	690	4,600	23.7	11.02	370	.42	10	109	2830
▲ 588°F•	9.4	1,357		1,084	3,388	813	943	6,287	32.4	14.45	507	.44	10	132	3305
▲ 688°F•	11.8	1,703		1,358	4,275	1026	1181	7,874	40.6	18.08	639	.46	10	155	3780
▲ 788°F•	14.2	2,049	See appropriate burner manual. Varies with burner.	1,632	5,225	1254	1419	9,460	48.8	21.61	772	.47	12	178	4205
▲ 888°F•	16.6	2,396		1,904	6,154	1477	1656	11,040	56.9	25.14	906	.49	12	201	4730
▲ 988°F•	18.8	2,713		2,176	7,038	1689	1892	12,614	65.0	28.67	1,031	.50	14	224	5205
▲ 988R°F•	17.2	2,482		1,991	6,442	1546	1731	11,540	59.5	28.67	954	.45	14	224	5205
▲ 1088°F•	21.5	3,103		2,452	7,933	1904	2132	14,214	73.2	32.20	1,184	.52	14	247	5680
▲ 1088R°F•	20.0	2,887		2,304	7,454	1789	2003	13,354	68.8	32.20	1,101	.49	14	247	5680
▲ 1188°F•	23.5	3,392		2,724	8,813	2115	2369	15,794	81.4	35.73	1,299	.53	14	270	6155
▲ 1288°F•	26.0	3,753		3,000	9,704	2329	2609	17,394	89.6	39.26	1,443	.55	14	293	6630
▲ 1388°F•	28.5	4,113		3,270	10,579	2539	2843	18,954	97.7	42.79	1,588	.56	14	316	7105
▲ 1488°F•	31.0	4,474		3,550	11,483	2756	3087	20,580	106.0	46.32	1,735	.58	16	339	7580
▲ 1588°F•	33.0	4,763		3,820	12,358	2966	3322	22,147	114.1	49.85	1,854	.59	16	362	8055
▲ 1688°F•	35.5	5,124		4,090	13,229	3175	3557	23,713	122.2	53.38	2,002	.61	16	385	8530
▲ 1688R°F•	34.5	4,979		3,980	12,875	3090	3461	23,073	118.9	53.38	1,945	.59	16	385	8530
▲ 1788°F•	38.0	5,485		4,370	14,138	3393	3800	25,333	130.5	56.91	2,152	.62	18	408	9005
▲ 1888°F•	40.5	5,845		4,640	15,008	3602	4035	26,900	138.6	60.44	2,303	.64	18	431	9480

▲ Substitute "BL" for light oil, "BGL" for gas light oil, "BG" for gas, or "H" for boiler only for use with approved burners. Add prefix "A" to designator for factory assembled unit (example, ABL-488), "P" for "B" for fire-tested package unit (example: PL-488).

* Substitute "S" for steam, "W" for water.

• For T-intermediate section(s) and tankless heater(s) add suffix "(number required) TIH".

For T-intermediate section(s) with cover plate(s) only add suffix "(number required) TIP".

For T-intermediate section(s) with storage heater(s) add suffix "(Number required) TISH."

△ Burner input based on maximum of 2,000 ft. altitude—for other altitudes consult Weil-McLain Distributor/Agent or Sales Office.

** No. 2 fuel oil—Commercial Standard Spec CS75-56. Heat value of oil—140,000 BTU/G.

○ Gas pressure required at control inlet for rated burner input based on 1,000 BTU/cu. ft., 0.60 specific gravity gas.

† Gross I = B = R ratings have been determined under the I = B = R provision governing forced draft boiler-burner units.

‡ Net I = B = R ratings are based on net installed radiation of sufficient quantity for the requirements of the building and nothing need be added for normal piping and pick-up. Water ratings are based on a piping and pick-up allowance of 1.15. Steam ratings are based on the following allowances: 488-588—1.333; 688—1.323; 788—1.301; 888—1.289; 988-1888—1.288. An additional allowance should be made for gravity hot water systems or for unusual piping and pick-up loads. Consult local Weil-McLain Distributor/Agent or Sales Office.

*** Based on average water temperature of 170°F. in heat distributing units.

**** Stack gas volume at outlet temperature.

□ With 0.10" W.C. positive pressure at flue collar.

NOTE: Water boilers tested for 50 PSIG, ASME water working pressure. Available upon special request at 80 P.S.I. working pressure. Steam boilers tested for 15 PSIG, ASME steam working pressure.

Boiler No.	Supply Tappings No. & Size*		Return Tappings No. & Size*	
	Steam	Water	Steam	Water
488	2-5"	2-5"	2-6"	2-6"
588	2-5"	2-5"	2-6"	2-6"
688	2-5"	2-5"	2-6"	2-6"
788	2-5"	2-5"	2-6"	2-6"
888	2-5"	2-5"	2-6"	2-6"
988	2-5"	2-5"	2-6"	2-6"
1088	2-5"	2-5"	2-6"	2-6"
1188	2-5"	2-5"	2-6"	2-6"
1288	3-5"	2-5"	2-6"	2-6"
1388	3-5"	2-5"	2-6"	2-6"
1488	3-5"	2-5"	2-6"	2-6"
1588	3-5"	2-5"	2-6"	2-6"
1688	3-5"	2-5"	2-6"	2-6"
1788	4-5"	2-5"	2-6"	2-6"
1888	4-5"	2-5"	2-6"	2-6"

Dimensions (Inches)							
A	B	C	D	E	L	W	H
23			10	54 ³ / ₄	32 ¹ / ₄	30	23 ³ / ₈
31			10	54 ³ / ₄	40 ¹ / ₄	38	31 ³ / ₈
39			10	54 ³ / ₄	48 ¹ / ₄	46	39 ³ / ₈
47			12	53 ³ / ₄	56 ¹ / ₄	54	47 ³ / ₈
55			12	53 ³ / ₄	64 ¹ / ₄	62	55 ³ / ₈
63			14	52 ³ / ₄	72 ¹ / ₄	70	63 ³ / ₈
71			14	52 ³ / ₄	80 ¹ / ₄	78	71 ³ / ₈
79			14	52 ³ / ₄	88 ¹ / ₄	86	79 ³ / ₈
87	39 ¹ / ₂		14	52 ³ / ₄	96 ¹ / ₄	94	87 ³ / ₈
95	47 ¹ / ₂		14	52 ³ / ₄	104 ¹ / ₄	102	95 ³ / ₈
103	55 ¹ / ₂		16	51 ³ / ₄	112 ¹ / ₄	110	103 ³ / ₈
111	63 ¹ / ₂		16	51 ³ / ₄	120 ¹ / ₄	118	111 ³ / ₈
119	47 ¹ / ₂		16	51 ³ / ₄	128 ¹ / ₄	126	119 ³ / ₈
127	31 ¹ / ₂	79 ¹ / ₂	18†	51 ³ / ₄	136 ¹ / ₄	134	127 ³ / ₈
135	39 ¹ / ₂	87 ¹ / ₂	18†	51 ³ / ₄	144 ¹ / ₄	142	135 ³ / ₈

* Use Piping Connections shown in manual.

† 16¹/₈" x 19⁷/₈" Oval Collar

No. 88 BURNER LENGTH CHART
DIMENSION "F"

Boiler Size	Carlin	Webster	Power-Flame	Gordon-Piatt
488R	21	37	31	26
488	21	37	31	26
588	21	37	31	29
688	21	37	34	29
788	21	32	34	29
888	21	32	34	29
988R	—	32	34	29
988	26	35	34	29
1088R	26	35	34	29
1088	26	35	34	29
1188	26	35	39	29
1288	26	35	39	29
1388	26	35	39	29
1488	26	35	39	31
1588	—	35	39	31
1688R	—	35	39	31
1688	—	35	39	31
1788	—	35	44	31
1888	—	35	44	31

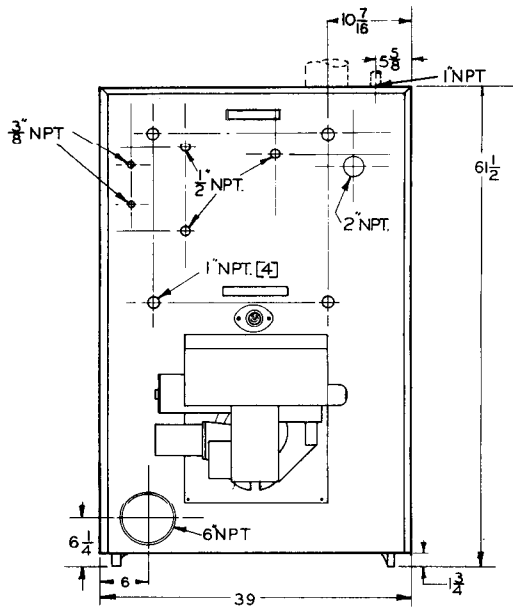

FRONT

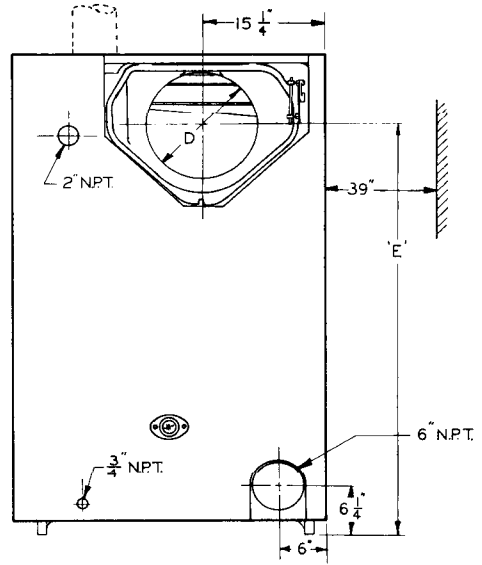

BACK

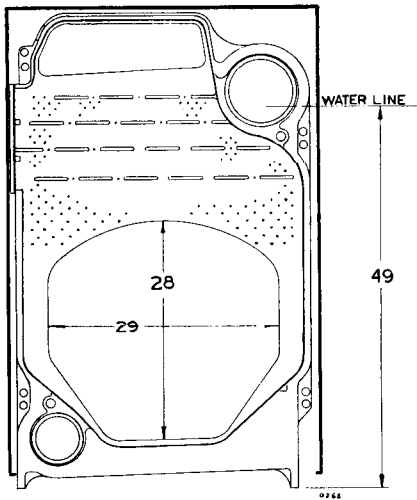

INTERMEDIATE

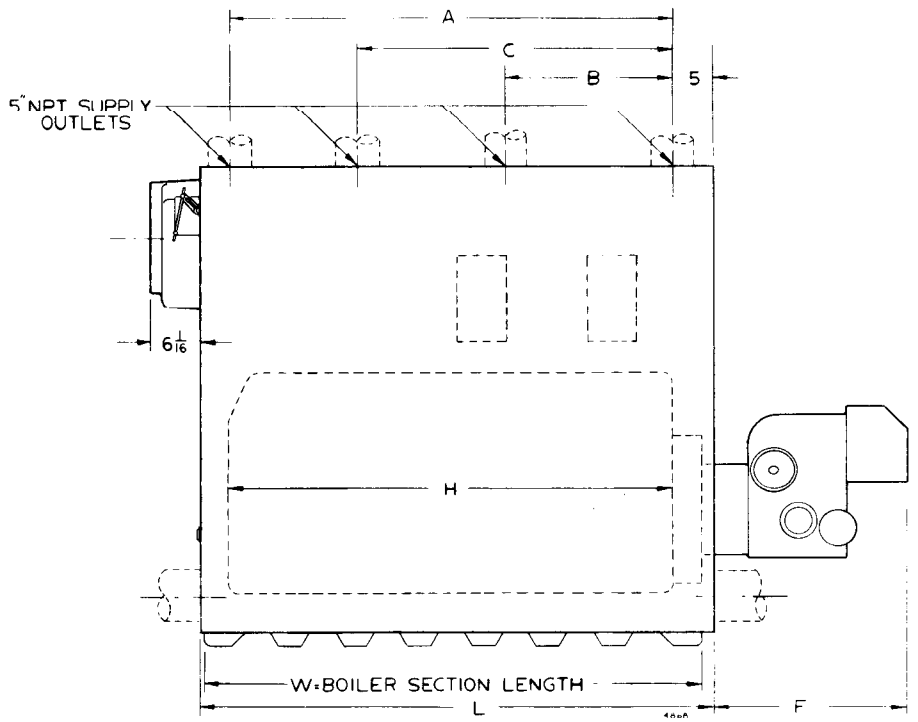

SIDE

Replacement Parts

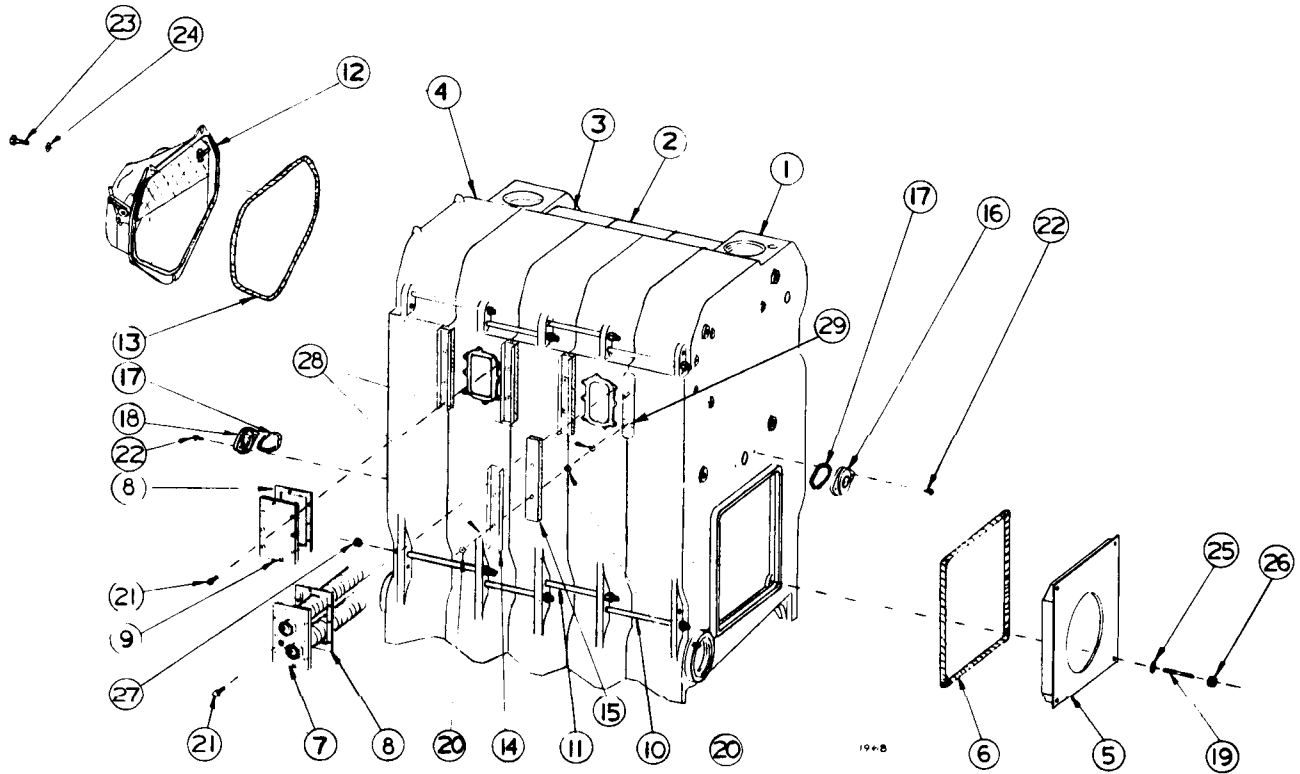

Weil McLain will attempt to stock major boiler replacement parts for at least 20 years. Items manufactured by others will normally have an equivalent part available for at least the same time period. Do not order replacement parts directly from Weil-McLain. Provide distributor with fuel type, and boiler size, type and series for proper parts replacement.

Ref.	Description	Part Number
1.	Front Section (8813)	316-301-150
2.	Regular Intermediate Section (8815)	316-301-160
3.	Tankless Intermediate Section (8816)	316-301-165
4.	Back Section (8818)	316-301-170
	Supply Intermediate Section (8814) (not shown)	316-301-155
5.	Burner Mounting Plate	Order for Specific Burner
6. and 13.	Sealing Rope— $\frac{1}{2}$ " (13' per joint, 7' for burner plate, 6' for collar)	■
7.	a. Tankless Heater (when used) #820	590-921-820
	b. Storage Heater (when used) #816	590-921-816
8.	Heater Plate Gasket	590-317-579
9.	Heater Cover Plate	450-030-934
10.	Draw Rod $\frac{5}{8}$ x 13"	560-134-505
11.	Draw Rod $\frac{5}{8}$ x 11"	560-134-495
12.	Draft Hood Collar Assembly (includes damper collar, damper, damper quadrant, locking plate, swivel, brackets and rope)	
	a. 10"—488 thru 688	340-004-606
	b. 12"—788 and 888	340-004-607
	c. 14"—988 thru 1388	340-004-608
	d. 16"—1488 thru 1688	340-004-609
	e. 18"—1788 and 1888	340-004-612
	Quadrant for Draft Collar	330-056-634
	Damper Blade for Draft Collar	460-003-646
	Damper Locking Plate for Draft Collar	563-530-784
14.	Cleanout Plate	450-030-925
15.	Insulation for Cleanout Plate	591-221-271
16. and 18.	Observation Port Assembly (includes frame, rope, gasket, plugs, and sight glass)	340-004-605
	Sight Glass	591-419-199
	Washer Gasket for Sight Glass $2\frac{1}{8}$ x $1\frac{1}{4}$ x $\frac{1}{8}$	590-317-580 ■
17.	Sealing Rope $\frac{3}{8}$ " (1' per observation port)	■
19.	Burner Mounting Plate Studs ($\frac{1}{2}$ x $3\frac{1}{2}$)"	■
20.	Cleanout Plate Nut $\frac{1}{4}$ "	■
21.	Cap Screw $\frac{1}{2}$ -13 x $\frac{3}{4}$ "	■
22.	Observation Port Screw 10-32 x $1\frac{1}{2}$ "	■
23.	Draft Collar Cap Screw $\frac{1}{2}$ " x $1\frac{1}{2}$ "	■
24.	Draft Collar Washer $1\frac{1}{16}$ "	■
25.	Burner Plate Washer $\frac{1}{2}$ "	■
26.	Burner Plate Nut $\frac{1}{2}$ "	■
27.	Draw Rod Nut $\frac{5}{8}$ "	■
28.	Cleanout Plate Washer $\frac{1}{4}$ "	■
29.	Cleanout Plate Carriage Bolt $\frac{1}{4}$ " x $1\frac{3}{4}$ "	■

■ available at local supply house.



WEIL-McLAIN
A United Dominion Company

Weil-McLain
500 Blaine Street
Michigan City, IN 46360-2388