



Water & steam boilers – Series 2

for use with Gas, Light Oil, & Gas/Light Oil – Fired Burners

Boiler Manual

- Installation
- Maintenance
- Startup
- Parts



For additional information, refer to . . .

Burner specification and data sheets

for burners pre-tested with model 88 boilers



WARNING

This manual must only be used by a qualified heating installer/service technician. Read all instructions before installing. Follow all instructions in proper order. Failure to comply could result in severe personal injury, death or substantial property damage.

NOTICE

When calling or writing about the boiler— Please have the boiler model number from the boiler rating label and the CP number from the boiler jacket.

INSTALLER

Consider piping and installation when determining boiler location. Any claims for damage or shortage in shipment must be filed immediately against the transportation company by the consignee.

USER

This manual is for use only by your qualified heating installer/service technician. Boiler and burner must be installed by a qualified service technician. We recommend regular service by a qualified service technician, at least annually.



Read before proceeding

Hazard Definitions

The following defined terms are used throughout this manual to bring attention to the presence of hazards of various risk levels, or to important information concerning the life of the product.

▲ DANGER Indicates presence of hazards that **will cause severe** personal injury, death or substantial property damage if ignored.

▲ WARNING Indicates presence of hazards that **can cause severe** personal injury, death or substantial property damage if ignored.

▲ CAUTION Indicates presence of hazards that **will or can cause minor** personal injury, death or substantial property damage if ignored.

NOTICE Indicates special instructions on installation, operation or maintenance that are important but not related to personal injury.

Read before proceeding:

▲ WARNING Read all instructions before installing. Failure to follow all instructions in proper order can cause severe personal injury, death or substantial property damage.

▲ WARNING Do not use petroleum-based cleaning or sealing components in boiler system. Severe damage to system components can result, causing substantial property damage.

▲ WARNING **Propane boilers only** — Your propane supplier mixes an odorant with the propane to make its presence detectable. In some instances, the odorant can fade and the gas may no longer have an odor.

- Propane gas can accumulate at floor level. Smell near the floor for the gas odorant or any unusual odor. If you suspect a leak, do not attempt to light the burner.
- Use caution when attempting to light a propane burner (or pilot burner). This should be done by a qualified service technician, particularly if flame outages (or pilot outages) are common.
- Periodically check the odorant level of your gas.
- Inspect boiler and system at least yearly to make sure all gas piping is leak-tight.
- Consult your propane supplier regarding installation of a gas leak detector. There are some products on the market intended for this purpose. Your supplier may be able to suggest an appropriate device.



Contents

Before installing boiler	4
Set boiler in place	7
Assembling the block	8
Perform hydrostatic pressure test11
Complete block assembly.12
Connect water boiler piping14
Connect steam boiler piping16
Install jacket20
Pipe tankless heaters25
Install water boiler controls.26
Install steam boiler controls27
Connect breeching and venting systems29
Install burner & wiring and fill system31
Install fuel piping32
Make final adjustments33
Handling ceramic fiber and fiberglass materials34
Ratings35
Dimensions36
Parts38

Before installing boiler

Installation must comply with —

1. State, provincial and local plumbing, heating and electrical codes.
2. Regulations of servicing utilities.
3. ASME Section IV, Low Pressure Boiler and Pressure Vessel Code.
4. National Fuel Gas Code, ANSI/NFPA 54, when applicable.
5. National codes where applicable.

Before selecting boiler location

1. Check for nearby connections to:
 - a. Fuel supply.
 - b. Electrical power.
 - c. System water or steam piping.
 - d. Venting systems - see page 29.
 - e. Combustion and ventilation air supply — see page 5.
2. Check area around boiler. Remove any combustible materials, gasoline and other flammable vapors and liquids.

WARNING Failure to keep boiler area clear and free of combustible materials, gasoline and other flammable liquids and vapors can result in severe personal injury, death and substantial property damage.

Provide clearance around boiler

1. Provide minimum clearances to combustible materials:
 - **Boiler top** — 24 inches.
 - **Boiler front** — 48 inches.
 - **Boiler flue** — 9 inches.
 - **Boiler rear** — 9 inches.
 - **Boiler sides** — 6 inches.
 - **Single-wall vent pipe** — 18 inches.
 - **Double-wall vent pipe** — refer to vent pipe manufacturer's recommendations for vent pipe clearances.
2. Boiler may be installed on combustible flooring.
3. See page 36 for boiler dimensions.

NOTICE Flue pipe/breeching clearances take precedence over jacket clearances.

4. Provide minimum clearances for servicing:
 - **Left side** — for cleaning and tankless heater removal — 39 inches.
 - **Rear** — for breeching — 36 inches.
 - Allow sufficient space on remaining sides for cleaning, servicing and burner installation. See burner literature for length and recommended service clearances.

Lay a foundation, if needed

1. Floor construction and condition must be suitable for weight of boiler when filled with water. See page 35 for approximate boiler operating weight.
2. A level concrete or brick foundation, constructed per Figure 1 and Figure 2 is required when:
 - a. A floor could possibly become flooded.
 - b. Non-level conditions exist.

Figure 1 Boiler foundation, when required

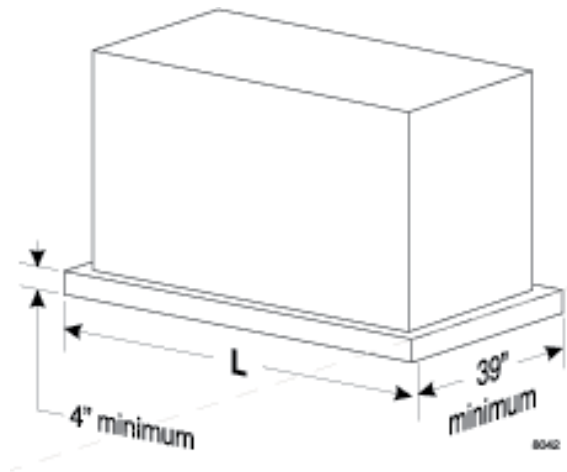

Figure 2 Boiler foundation (see Figure 1)

Boiler model number	Length, L, minimum (inches)
488	33
588	41
688	49
788	57
888	65
988	73
1088	81
1188	89
1288	97
1388	105
1488	113
1588	121
1688	129
1788	137
1888	145

Before installing boiler *(continued)*

Combustion and ventilation air openings

⚠ WARNING

Adequate combustion and ventilation air must be provided to assure proper combustion and prevent possibility of flue gas leakage and carbon monoxide emissions, causing severe personal injury or death.

Do not install an exhaust fan in boiler room. Incorrect burner operation can result.

When combustion and ventilation air enters through side wall openings, ensure that the openings comply with the requirements of Figure 3 and Figure 4.

Opening sizes must comply with state, provincial or local codes. In the absence of local requirements, use the National Fuel Gas Code, ANSI/NFPA 54). The following information is taken from ANSI/NFPA 54. For details and information not addressed below, refer to the standard.

Combustion air openings to inside

Required volume of interior spaces

ANSI/NFPA 54 allows combustion air to be supplied through openings to interior spaces **if the volume of the connected interior spaces meets the minimum volume required by the standard.**

The minimum volume of interior spaces can be taken as 50 cubic feet per 1,000 Btuh of all appliances in the spaces, or the minimum volume can be calculated using the formulas given in ANSI/NFPA 54. Exception: If the air infiltration rate for the spaces is known to be less than 0.40 air changes per hour, the minimum volume must be calculated as specified in the standard.

Inside air opening sizes and locations

For spaces that provide the minimum volume required by ANSI/NFPA 54, the air openings must be sized per the following:

Combining spaces on the same story — Each opening shall have a minimum free area of 1 in²/1000 Btuh (2200 mm²/kW) of the total input rating of all appliances in the space but not less than 100 in² (0.06 m²). One opening shall commence within 12 inches (300 mm) of the top, and one opening shall commence within 12 inches (300 mm) of the bottom, of the enclosure. The minimum dimension of air openings shall be not less than 3 inches (80 mm).

Combining spaces in different stories — The volumes of spaces in different stories shall be considered as communicating spaces where such spaces are connected by one or more openings in doors or floors having a total minimum free area of 2 in²/1000 Btuh (4400 mm²/kW) of total input rating of all appliances.

Figure 3 Combustion and ventilation air openings — Boiler room below grade

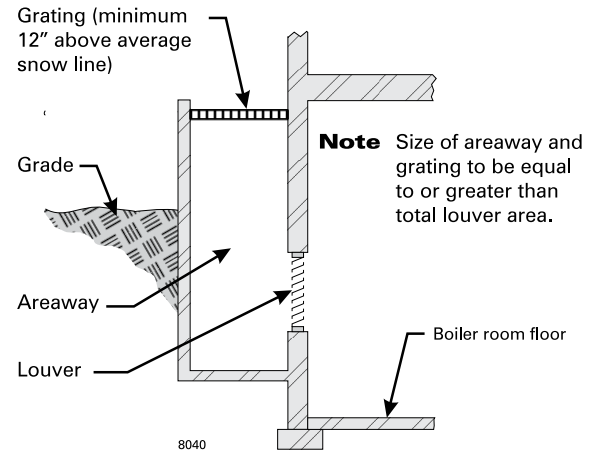
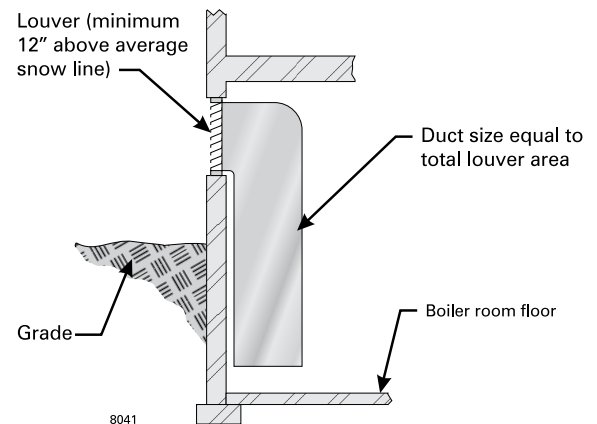

Figure 4 Combustion and ventilation air openings — Boiler room partially or completely above grade



Combustion air openings to outside

Outdoor combustion air can be taken through permanent openings (TWO or ONE), as described in the following. The minimum dimension of air openings shall not be less than 3 inches (80 mm).

Outside openings: TWO permanent openings method

Two permanent openings, one commencing within 12 inches (300 mm) of the top and one commencing within 12 inches (300 mm) of the bottom of the enclosure shall be provided. The openings shall communicate directly, or by ducts, with the outdoors or spaces that



Before installing boiler *(continued)*

freely communicate with the outdoors, as follows:

- Where directly communicating with the outdoors or where communicating to the outdoors through vertical ducts, each opening shall have a minimum free area of 1 in²/4000 Btuh (550 mm²/kW) of total input rating of all appliances in the enclosure.
- Where communicating with the outdoors through horizontal ducts, each opening shall have a minimum free area of 1 in²/2000 Btuh (1100 mm²/kW) of total input rating of all appliances in the enclosure.

Outside openings: ONE permanent opening method

One permanent opening, commencing within 12 inches (300 mm) of the top of the enclosure, shall be provided. The appliance shall have clearances of at least 1 in. (25 mm) from the sides and back and 6 inches (150 mm) from the front of the appliance. The opening shall directly communicate with the outdoors or shall communicate through a vertical or horizontal duct to the outdoors or spaces that freely communicate with the outdoors and shall have a minimum free area of the following:

- (1) 1 in²/3000 Btu/hr (700 mm² per kW) of the total input rating of all appliances located in the enclosure, and . . .
- (2) Not less than the sum of the areas of all vent connectors in the space.

Combustion air — combination indoor and outdoor openings

ANSI/NFPA 54 allows combustion air to be taken from a combination of openings to outside and to interior spaces. Follow all requirements of the standard to determine the minimum volume of interior spaces and to calculate minimum sizes of openings.

Engineered Installations

Engineered combustion air installations shall provide an adequate supply of combustion, ventilation, and dilution air and shall be approved by the authority having jurisdiction.

Mechanical Combustion Air Supply

Where all combustion air is provided by a mechanical air supply

system, the combustion air shall be supplied from outdoors at the minimum rate of 0.35 ft³/minute per 1000 Btuh (0.034 m³/min per kW) for all appliances located within the space.

- Where exhaust fans are installed in the building, additional air shall be provided to replace the exhausted air.
- Each of the appliances served shall be interlocked to the mechanical air supply system to prevent main burner operation where the mechanical air supply system is not in operation.
- Where combustion air is provided by the building's mechanical ventilation system, the system shall provide the specified combustion air rate in addition to the required ventilation air.

Louvers, Grilles, and Screens.

The required size of openings for combustion, ventilation, and dilution air shall be based on the **net free area** of each opening.

Where the free area through a design of louver or grille or screen is known, it shall be used in calculating the size opening required to provide the free area specified.

Where the louver and grille design and free area are not known, it shall be assumed that wood louvers will have 25 percent free area, and metal louvers and grilles will have 75 percent free area.

Non-motorized louvers and grilles shall be fixed in the open position.

Minimum screen mesh size

Screens shall not be smaller than ¼ inch mesh.

Motorized louvers

Motorized louvers shall be interlocked with the appliance so they are proven in the full open position prior to main burner ignition and during main burner operation. Means shall be proved to prevent the main burner from igniting should the louver fail to open during burner startup, and to shut down the main burner if the louvers close during burner operation.



Set boiler in place

WARNING Ensure the equipment and cables used for lifting are designed to handle the load. See Figure 5 for approximate weights of model 88 section assemblies. Failure to comply can result in severe personal injury, death or substantial property damage.

NOTICE Cables used for lifting are NOT provided by Weil-McLain.

For packaged boiler:

1. Remove top jacket panels. Set aside until after boiler is piped.

WARNING The boiler contains ceramic fiber and fiberglass materials. Use care when handling these materials per instructions on "Handling ceramic fiber and fiberglass materials," page 34 of this manual. Failure to comply could result in severe personal injury.

2. Remove lag screws (2 in front, 2 in rear) from shipping rails.
3. Remove boiler from skid. See Figure 5 for lifting weight.
 - Using crane — hook middle of each cable to eye of crane.
 - Using hoist — hook middle of each cable to hoist. Raise boiler off skid. Use pipe rollers under skid angles to roll boiler.
4. Place boiler in final position. Center boiler on foundation, if used.
5. Level boiler. Shim under skid angles, if necessary.
6. Cut off cables.

WARNING Cables are not intended for long-term usage. Cables may corrode inside boiler, weakening their lifting strength. Failure to remove cables can result in severe personal injury, death or substantial property damage.

7. Proceed to "Perform hydrostatic pressure test," page 11.

For block assembly:

1. Remove lag screws (2 in front, 2 in rear) from shipping rails.
2. Remove boiler from skid. See Figure 5 for lifting weight.
 - Using crane – attach free end of cables to eye of crane.
 - Using hoist – attach free end of cables to hoist. Raise boiler off skid. Use pipe rollers under steel skid angles to roll boiler.
3. Place boiler in final position. Center boiler on foundation, if used.
4. Level boiler. Shim under skid angles, if necessary.
5. Cut off cables.

WARNING Cables are not intended for long-term usage. Cables may corrode inside boiler, weakening their lifting strength. Failure to remove cables can result in severe personal injury, death or substantial property damage.

6. Inspect block assembly for disjointed sections. Check gas-tight seal of flue collector hood and cleanout plates.

Figure 5 Section assembly lifting weights

Boiler model number	Approximate lifting weight (pounds)	Minimum sling length — (from crane hook to boiler lifting lugs)
488	2928	2' 6"
588	3490	3' 0"
688	4152	4' 0"
788	4714	4' 6"
888	5276	5' 0"
988	5838	6' 0"
1088	6400	6' 6"
1188	7062	7' 0"
1288	7624	8' 0"
1388	8186	8' 6"
1488	8748	9' 0"
1588	9310	10' 0"
1688	9872	10' 6"
1788	10,584	11' 0"
1888	11,146	12' 0"

WARNING Gas tight seal must be maintained to prevent possible flue gas leakage and carbon monoxide emissions, resulting in severe personal injury or death.

- a. Check inside section assembly for any light passing through unsealed areas.
 - b. Mark all unsealed areas.
 - c. At unsealed areas, check for:
 - Damaged gaskets.
 - Sealing rope not in place.
 - Loose bolts or nuts.
 - d. Correct all conditions and repeat step b. If unsealed areas still exist, contact your Weil-McLain distributor or sales office before continuing installation.
7. Proceed to "Perform hydrostatic pressure test," page 11.

Assembling the block

⚠ WARNING Sections are top heavy. Unbolted sections may fall if not supported, resulting in severe personal injury or death.

Prepare and position back section

1. Apply $\frac{1}{8}$ " continuous bead of sealing rope adhesive in sealing rope grooves. See Figure 6. **Do not get any adhesive on machined port surfaces.**
2. Place $\frac{1}{2}$ " sealing rope in groove. Around curves, grasp at 1" intervals and push together. Do not stretch.

⚠ WARNING Do not pre-cut rope. Gas tight seal must be maintained to prevent possibility of flue gas leakage and carbon monoxide emissions, causing severe personal injury or death. Cut rope as each section is completed.

3. Remove any grit from port machined surfaces with clean rag.

⚠ WARNING Do not use petroleum-based cleaning or sealing compounds in boiler system. Severe damage to system components can result, causing substantial property damage.

4. Place 9" and 6" sealing rings in appropriate port openings. See Figure 6. If sealing ring slips out of groove, stretch ring gently for several seconds, then reposition in groove.
5. Apply continuous bead of silicone sealant no larger than $\frac{1}{16}$ " around entire outside edge of **outer** machined surface of port. Refer to Figure 7. **Do not apply silicone sealant on, next to or under sealing ring.**

⚠ WARNING Silicone sealant applied as specified above prevents unburned oil vapors from coming in contact with sealing ring. Vapor contact can damage rings, resulting in severe damage to boiler and substantial property damage.

6. Hoist back section upright. Then temporarily screw a 6-inch threaded pipe at least 36 inches long into the lower (return) tapping.
7. Hoist the section and put into position.
8. Place a block under the 6-inch pipe to hold the back section upright and plumb.

⚠ CAUTION The back section must be plumb before installing other sections to ensure the block will assemble correctly.

9. The 6-inch support pipe and block can be removed after several sections have been installed, and the assembly is stable.

10. Install intermediate sections as described on the following page.

Figure 6 Sealing rope installation

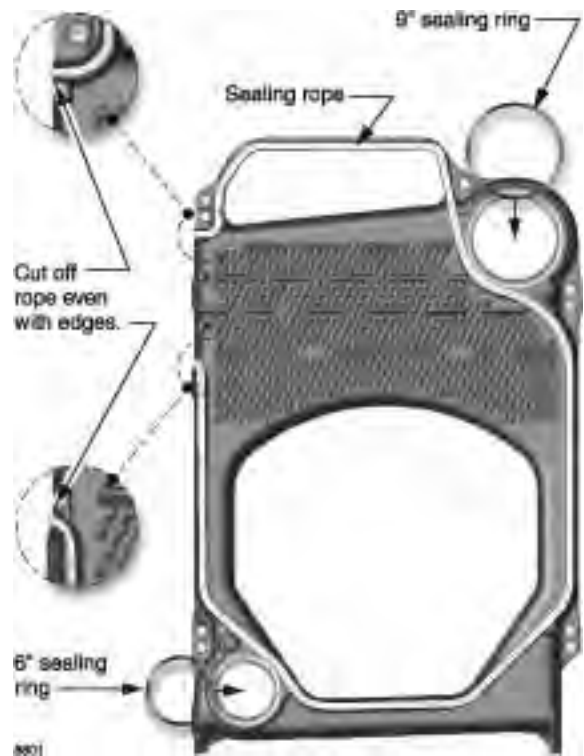
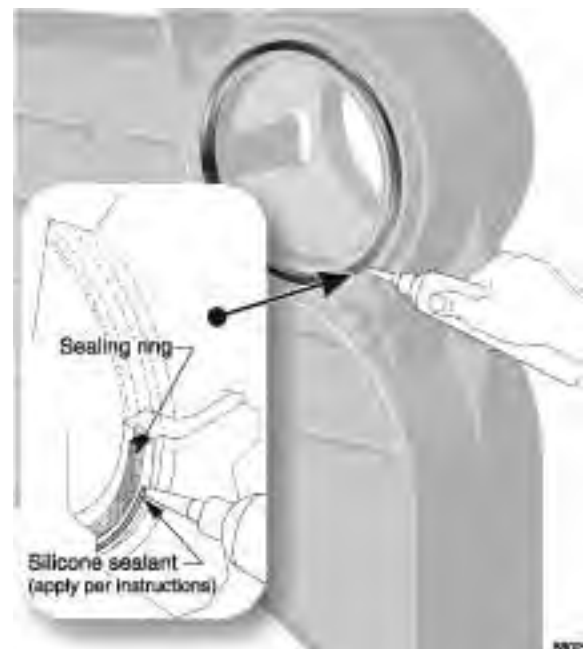

Figure 7 Silicone sealant



Assembling the block

WARNING Sections are top heavy. Unbolted sections may fall if not supported, resulting in severe personal injury or death.

Install intermediate sections

1. Remove and discard $\frac{3}{8}$ " diameter shipping tie rods.
2. Remove grit from port machined surfaces with clean rag.

WARNING Do not use petroleum-based cleaning or sealing compounds in boiler system. Severe damage to system components can result, causing substantial property damage.

3. Position intermediate section so aligning lugs fit into sockets of next section. See Figure 8.
4. Install TI (tankless intermediate) and SI (supply intermediate) sections (when used) in order shown in Figure 9, page 10.
5. Draw sections together until metal-to-metal contact is made around machined port openings (see Figure 8):
 - a. Oil threads on 4 draw rods. Install washer and nut on end to be tightened. Use nut only on other end.
 - b. Uniformly draw sections together, starting at washer/nut end.

NOTICE Important — Leave an equal amount of thread on each end of the draw rod. This is needed to allow securing the jacket support brackets in place.

- c. Draw rods should be torqued to a range of 100 to 120 ft-lbs. Do not back off draw rods.
- d. Metal-to-metal contact will be achieved around port openings. See Figure 8. If gap occurs, it should be no greater than .032". Check with feeler gauge.
- e. If, for any reason, gap around machined port opening exceeds .032", check for rope extending from rope grooves, dirt on port openings or sockets, or misaligned lugs. If corrections are made and gap still exists, contact your Weil-McLain distributor or sales office before continuing installation.

Figure 8 Sealing ring installation and port alignment

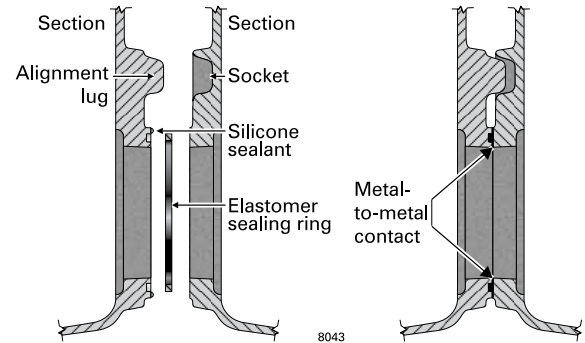

CAUTION After erecting first intermediate section, check both sections for plumb. Failure to plumb sections can cause misaligned piping and breeching, possibly resulting in property damage.

6. Repeat steps 1-5.
7. Check each section for proper sealing rope position before proceeding to next section.

WARNING Failure to position sealing rope properly can cause boiler to not seal gas-tight. Gas tight seal prevents possible flue gas leakage and carbon monoxide emissions, resulting in severe personal injury or death.

8. Install remaining intermediate sections and front section using the same procedure.

If using tankless heater (TI) sections

- Install tankless heaters and gaskets or heater cover plates and gaskets. Use $\frac{3}{8}$ " x $\frac{3}{4}$ " studs, washers and nuts.



Assembling the block *(continued)*

Figure 9 Section arrangement

Boiler model number W = water S = steam	Max. number of tankless heaters	Section arrangement (all heaters must be on left side of boiler)
		F = front / B = back / I = Intermediate TI = tankless intermediate SI = supply intermediate (steam only) "I" can be substituted for "TI" sections
488 W&S	1	F • TI • I • B
588 W&S	2	F • TI • I • TI • B
688 W&S	2	F • TI • I • TI • I • B
788 W&S	3	F • TI • I • TI • I • TI • B
888 W&S	3	F • TI • I • TI • I • TI • I • B
988 W&S	4	F • TI • I • TI • I • TI • I • TI • B
1088 W&S	4	F • TI • I • TI • I • TI • I • TI • I • B
1188 W&S	5	F • TI • I • TI • I • TI • I • TI • I • TI • B
1288 W	5	F • TI • I • TI • I • TI • I • TI • I • TI • I • B
1288 S	4	F • TI • I • TI • I • SI • I • TI • I • TI • I • B
1388 W	6	F • TI • I • TI • I • TI • I • TI • I • TI • I • TI • B
1388 S	6	F • TI • I • TI • I • TI • SI • TI • I • TI • I • TI • B
1488 W	6	F • TI • I • TI • I • TI • I • TI • I • TI • I • TI • I • B
1488 S	5	F • TI • I • TI • I • TI • I • SI • I • TI • I • TI • I • B
1588 W	7	F • TI • I • TI • I • TI • I • TI • I • TI • I • TI • I • TI • B
1588 S	7	F • TI • I • TI • I • TI • I • TI • SI • TI • I • TI • I • TI • B
1688 W	7	F • TI • I • TI • I • TI • I • TI • I • TI • I • TI • I • TI • I • B
1688 S	7	F • TI • I • TI • I • TI • SI • TI • I • TI • I • TI • I • TI • I • B
1788 W	8	F • TI • I • TI • I • TI • I • TI • I • TI • I • TI • I • TI • I • TI • B
1788 S	8	F • TI • I • TI • SI • TI • I • TI • I • TI • SI • TI • I • TI • I • TI • B
1888 W	8	F • TI • I • TI • I • TI • I • TI • I • TI • I • TI • I • TI • I • TI • I • B
1888 S	6	F • TI • I • TI • I • SI • I • TI • I • TI • I • SI • I • TI • I • TI • I • B



Perform hydrostatic pressure test

Prepare boiler and test:

1. See Figure 10 and Figure 11 for tapping locations. Install:
 - a. Boiler drain (not furnished).
 - b. Water pressure gauge — for test only. Be sure gauge can handle test pressure — see step 3.
 - c. Air vent in upper tapping (K).
2. Plug remaining tappings.

CAUTION Do not pressure test with any control installed. Damage to control can occur due to overpressure.

3. Fill boiler. Vent all air. Pressure test at least 10 minutes at a pressure not less than the following:
 - a. **Steam boiler: Between 45 and 55 psig.**
 - b. **Water boiler: 1½ times maximum allowable working pressure (MAWP) stamped on the boiler nameplate, located on boiler jacket front panel.**

NOTICE Do not exceed above test pressures by more than 10 psig.

WARNING Do not leave boiler unattended. Cold water fill could expand and cause excessive pressure, resulting in severe personal injury, death or substantial property damage.

4. Check for maintained gauge pressure and leaks. Repair if found.

WARNING Leaks must be repaired at once. Failure to do so can damage boiler, resulting in substantial property damage.

WARNING Do not use petroleum-based cleaning or sealing compounds in boiler system. Severe damage to system components can result, causing substantial property damage.

5. Drain boiler and remove air vent, boiler drain and gauge. Remove plugs from tappings that will be used for controls and accessories.

Figure 10 Boiler tapping locations and sizes (see Figure 11)

Location	Size	Steam	Water
A	2"	Steam relief valve and/or Skim tapping	High limit Manual reset limit
B	2"	Steam relief valve	Water relief valve
L	1"	Secondary probe LWCO	Not used — Plug
C1 & C2	1"	Low water cut-offs	Alternate low water cut-offs
C1		—	Combination high and low limit control
D1 & D2	1"	Alternate low water cut-offs	Firing rate temperature control (when used) Low water cut-offs
E1 & E2	½"	Gauge glass	—
F1 & F2	¾"	Try cock tappings	—
G	¾"	Pressure limit control, Pressure operating control and pressure gauge, Firing rate pressure control (when used)	Combination pressure-temperature gauge
H	¾"	Boiler drain (see Figure 17, page 15, for system blow-off (drain) valve locations and sizes)	Boiler drain
K	1"	—	Piping to compression tank or automatic air vent
M	2"	Blowdown/drain	—

Figure 11 Boiler tappings

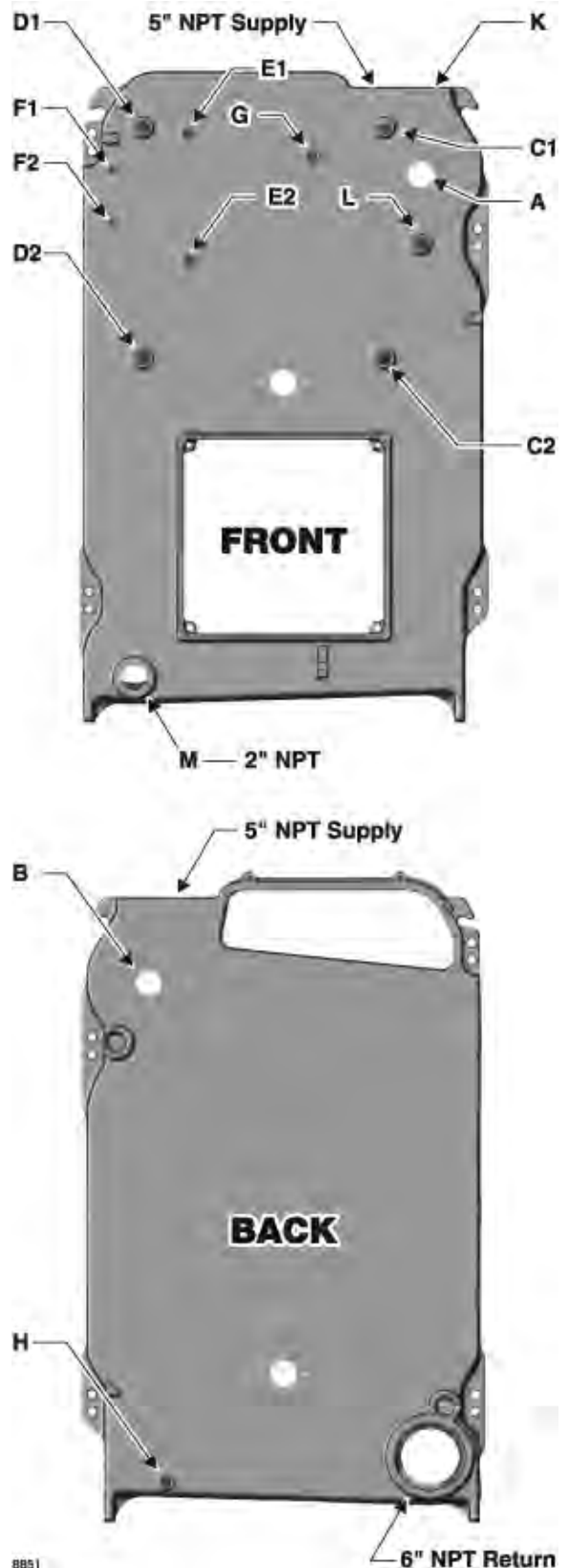



Complete block assembly

Install burner mounting plate on front section

1. Install four ½" x 3½" studs to secure burner mounting plate to section:
 - a. Thread and lock together two nuts on rounded end of stud. Thread flat end of stud into one of four holes located around opening.
 - b. Remove nuts.
 - c. Repeat steps a and b for remaining studs.
2. Install burner mounting plate:
 - a. Apply ⅛" continuous bead of sealing rope adhesive in groove around opening in section.
 - b. Position ½" sealing rope in groove. Overlap ends at least one inch.
 - c. Install burner mounting plate with part number and the word, "UP," positioned at top. Use ½" washers and nuts.

Install observation port assemblies on front and back sections

1. Install front observation port assembly:
 - a. Apply ⅛" continuous bead of sealing rope adhesive in groove on observation port.

- b. Position ⅜" sealing rope in groove.
 - c. Secure assembly to section. Use 10-32 x ¾" truss-head screws.
2. Repeat above steps for back observation port assembly.

Insert HXT-bars

1. See Figure 12, page 12.
2. Flue HXT-bars are identified by painted ends. They must be inserted as shown, with the HXT-bars in the sequence:
 - **Top** position
 - **red**-tipped, HXT-bar 24 inches long — place on the top row of pins.
 - **Middle** position
 - **white**-tipped HXT-bar, 26 inches long — place on the first row of pins below the top clean-out plate boss.
 - **Bottom** position
 - **blue**-tipped HXT-bar, 34 inches long — place on the first row of pins below the bottom cleanout plate boss.

Figure 12 Insert HXT-bars through cleanout openings as shown below (omit the bottom, blue-tipped, HXT-bar in the opening between the front section and the first intermediate section)

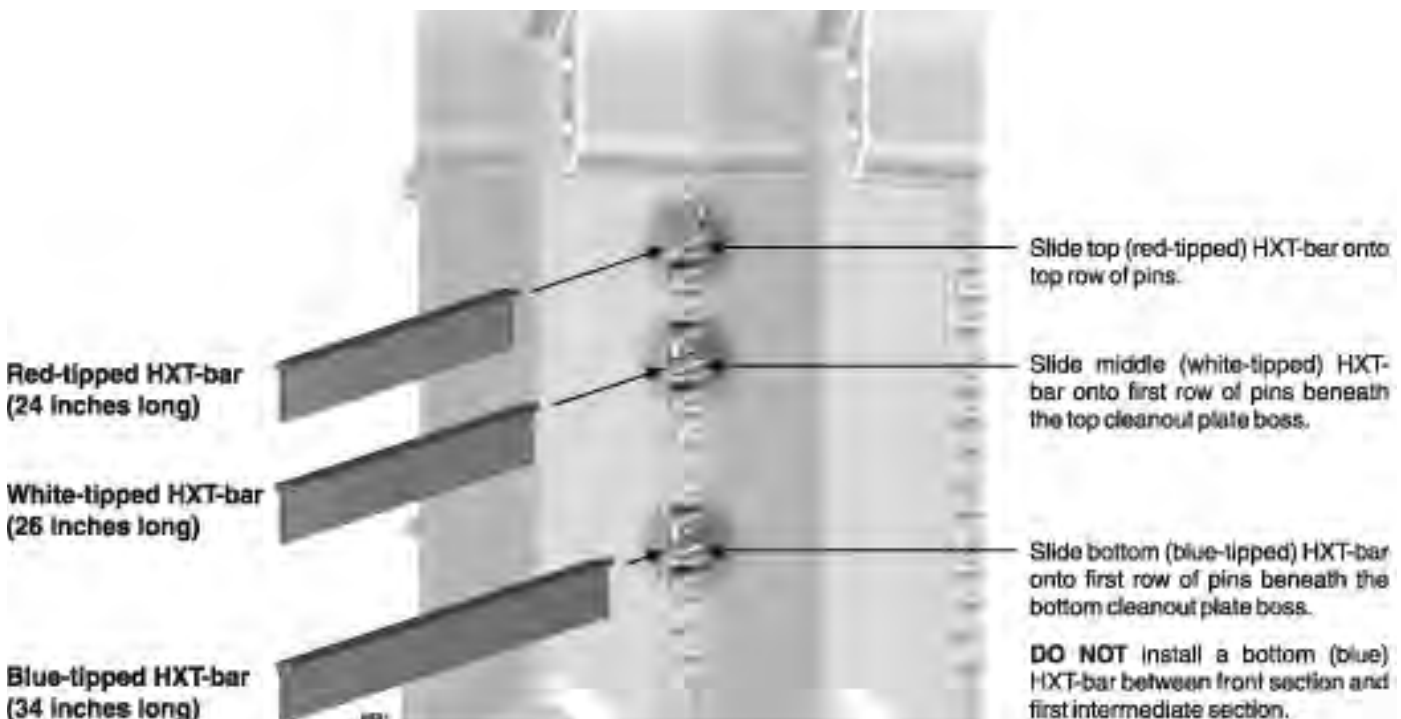

Complete block assembly *(continued)*

NOTICE DO NOT insert a bottom HXT-bar into the opening between the FRONT section and the first intermediate section.

- To remove flue HXT-bars when required to clean the boiler flueways, grab the end of each HXT-bar with pliers and pull straight out. Clean HXT-bars and replace as shown in Figure 12, page 12.

Install cleanout plates

WARNING Cleanout plates must be installed gas-tight to prevent possibility of flue gas leakage and carbon monoxide emissions, resulting in severe personal injury or death.

- See Figure 13.
- Position two $\frac{1}{4}$ " x $1\frac{3}{4}$ " carriage bolts in cleanout opening, between the cleanout plate bosses, as shown. Secure with washers and nuts.
- Place woven fiberglass gasket over carriage bolts.
- Mount cleanout plate over opening. Secure with nuts and washers.
- Repeat steps 1 through 3 for remaining cleanout plates.

Install draft hood collar

- Install $\frac{1}{8}$ " continuous bead of sealing rope adhesive in groove on draft hood collar.
- Position $\frac{1}{2}$ " sealing rope in groove. Overlap ends of rope at least 1 inch.
- Mount collar over flueway outlet on back section. Secure with $\frac{1}{2}$ x $1\frac{1}{2}$ " hex head cap screws and washers.

Figure 13 Cleanout plate assembly

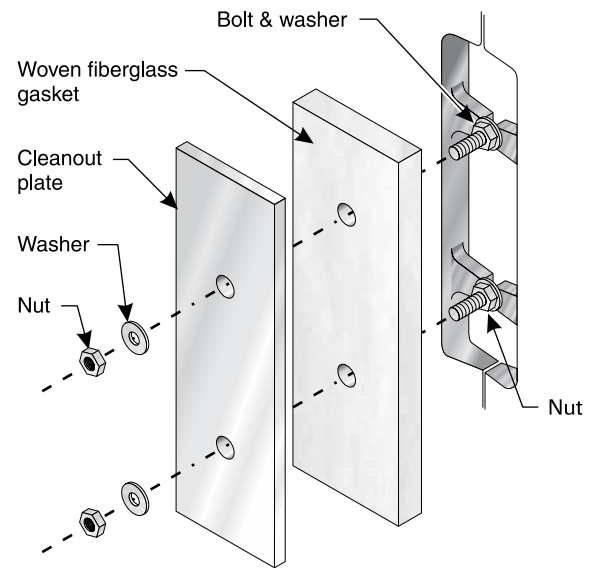

8025

WARNING The boiler contains ceramic fiber and fiberglass materials. Use care when handling these materials per instructions on page 34 of this manual. Failure to comply could result in severe personal injury.



Connect water boiler piping

General water piping information

1. System water supply and return piping should be installed and piping connections attached to boiler before erecting jacket or installing controls.
2. Do not pipe in through supply and out through return. This creates reverse water flow through boiler that must not be used.
3. When installing in a system in which return water temperature can drop below 140°F, apply the by-pass piping with by-pass pump as shown in .

Install piping

Install piping as shown in Figure 14, page 14 and Figure 18, page 15 (if applicable) for single boilers. For multiple boilers, see Figure 19, page 15.

CAUTION Improperly piped systems or undersized piping can contribute to erratic boiler operation and possible boiler or system damage.

1. Connect supply and return piping:
 - a. Size according to tables below.
 - For **known flow rates or higher flow rate** (less than 20°F temperature rise) through boiler, see Figure 15.
 - For **unknown flow rates**, size piping per Figure 17, page 15, using 20°F temperature rise through boiler.

WARNING Flow at higher rates than shown in the tables in this manual for given pipe sizes can damage the boiler, causing substantial property damage.

- b. Locate circulator in supply piping.
 - c. For return piping, use full diameter pipe for 10 times that diameter before making any reduction. For example, a 4-inch return should not be reduced any closer to boiler return tapping than 40 inches.
 - d. Install system blow-off (drain) valve in lowest part of return piping close to boiler. ASME minimum size requirements are given in Figure 17, page 15.
2. Install expansion tank:
 - a. **Closed type** – connect to 1" tapping "K" (see page 11). Use 1" NPT piping. Any horizontal piping must pitch up toward tank at least 1 inch per each 5 feet of piping.
 - b. **Diaphragm type** – Refer to tank manufacturer's literature for location. Install automatic air vent in "K" tapping.
 - c. Connect cold water fill to expansion tank piping. Figure 14 shows typical piping when using a closed type tank. Connect to the same location as the expansion tank connects to the system when using a diaphragm type tank.
 - d. Also shown are recommended valves and water meter, when used. Water meter will detect added make-up water, indicating leaks in system.

Figure 14 Water boiler piping, typical

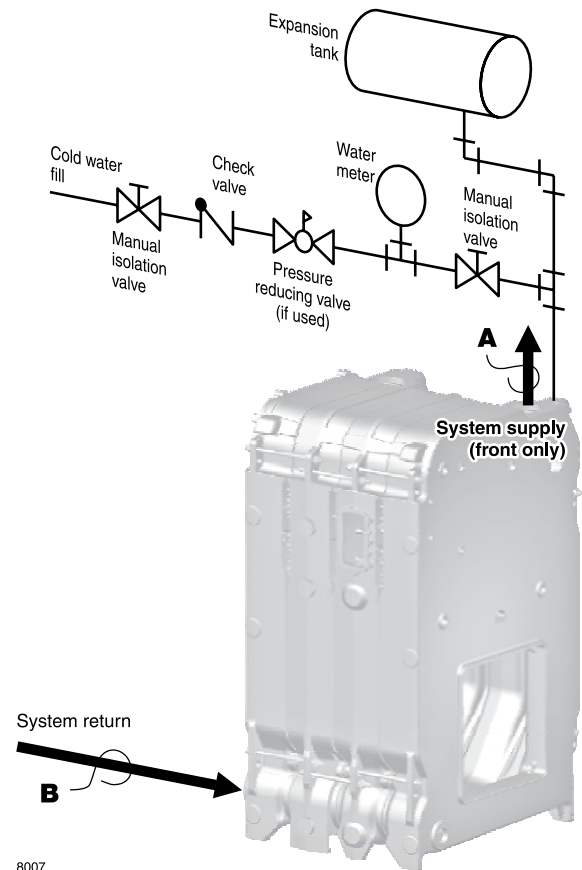

Figure 15 Recommended minimum pipe sizes for known flow rates (note 1)

Water flow rate GPM	Supply pipe size A	Return pipe size B
Up to 35	2"	2"
36–50	2½"	2½"
51–77	3"	3"
78–142	4"	4"
143–237	5"	5"
238–404	6" (note 2)	6"

- Note 1 High temperature rise through boiler is permissible when boiler piping connections are sized per this table. **Intermittent** flow at **high** velocities may damage any boiler.
- Note 2 6-inch piping requires nipples and 5" x 6" reducing couplings (provided with 1288 through 1888 boilers only). The total pressure drop through the 1888 boiler using the nipple and reducing coupling will not exceed ¼ PSI. For smaller boilers, the pressure drop will be less.



Connect water boiler piping *(continued)*

Figure 16 Recommended minimum pipe sizes when flow rate is not known (see Figure 14, page 14) (note 1)

Boiler model	Supply pipe size A	Return pipe size B
488	3"	3"
588 – 788	4"	4"
888 – 1188	5"	5"
1288 – 1888	6" (note 2)	6" (note 2)

Note 1 Pipe sizes are based on a 20°F temperature rise through the boiler. For applications with higher flow rates (lower temperature rise), determine the flow rate and use Figure 15, page 14 to size the piping.

Note 2 6-inch piping requires nipples and 5" x 6" reducing couplings (provided with 1288 through 1888 boilers only). The total pressure drop through the 1888 boiler using the nipple and reducing coupling will not exceed ¼ PSI. For smaller boilers, the pressure drop will be less.

Figure 17 ASME blowoff/drain valve size

Boiler model	Minimum blow-off valve size
488 – 588	1"
688 – 1088	1¼"
1188 – 1888	1½"

Piping multiple boilers

- See Figure 18. (Expansion tanks, relief valves and other accessories are required, but omitted from the illustration for simplicity.)
- The boiler piping circuits are referred to as the secondary circuits in the following.
- The legend for Figure 18 and boiler pump sizing recommendations follow:

- A** Size boiler pump GPM based on the following:
- Temp rise = Operating limit temp – Return water temp
 - $$GPM = \frac{\text{Boiler Gross Output, Btuh}}{\text{Temperature rise} \times 500}$$
 - Calculate only secondary (boiler) piping circuit resistance. Allow for head loss through the boiler equal to three 90 degree elbows of secondary pipe size.
 - Operate each boiler and its pump with a Weil-McLain boiler control panel.
 - Size secondary (boiler) circuit piping using the flow rate ranges given in Figure 17, page 15.
- B** Primary pump GPM and head calculation should not include secondary boiler circuits. Primary pump can operate continuously during heating season.
- C** Connection to primary circuit — Space 12" maximum or as close as practical.
- D** Check valve.
- E** Hand valve.

Figure 18 By-pass piping for return water less than 140°F

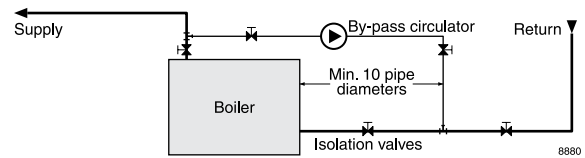

By-pass circulator sizing:

- Size system circulator as required. Determine GPM and head requirements.
- Provide a by-pass circulator for EACH boiler. The flow rate for each by-pass circulator will be:

$$\text{Flow} = \frac{1}{4} \times (\text{System circulator GPM}) \div (\# \text{ of boilers})$$
- All circulators must run at the same time.
- Example: For a 1,000,000 Btuh single boiler, with system temperature drop of 20°F:
 - System GPM = 1,000,000 ÷ 20 ÷ 500 = 100 GPM
 - By-pass GPM = ¼ x 100 GPM = 25 GPM
 - Determine by-pass circuit head loss for pipe size and fittings used.
- In most applications, a standard booster pump should be adequate.

Figure 19 Multiple water boiler piping

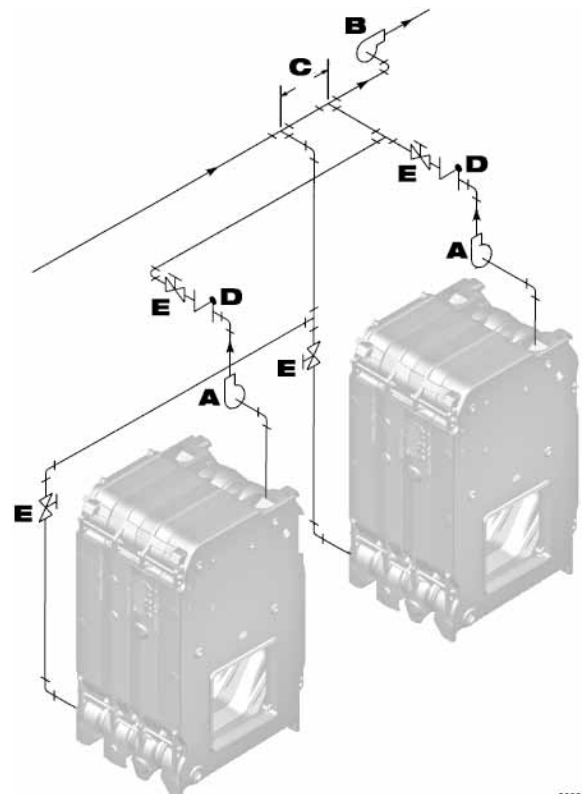



Connect steam boiler piping

General steam piping information:

1. Hartford loop piping arrangement and wet return are required for steam boilers. Use the Hartford loop for both pumped-return and gravity-return systems.
2. Maintain 24-inch minimum from waterline to bottom of header (63" from bottom of section).
3. When using condensate receiver, feed pump must be energized by boiler-mounted pump controller.
4. Install piping:
 - a. Install piping as shown on page 17 through page 18 for single boilers. See page 19 for additional requirements when piping multiple boilers.
 - b. Return pipe sizing.
 - Pumped return — Size return piping by pump.
 - Gravity return — Size gravity return same as Hartford loop equalizer pipe size.
 - c. Drain valve — Install system drain valve in lowest part of return piping close to boiler. See Figure 17, page 15, for sizing.
 - d. Cold water fill piping — Connect cold water fill piping as shown in Figure 20. Also shown are recommended valves and water meter, if used. Water meter will detect added makeup water, indicating leaks in system.
 - e. Condensate return piping:
 - Satisfactory operation of any steam heating system depends on adequate return of condensate to maintain steady water level.
 - Avoid adding excessive amounts of raw make-up water.
 - Where condensate return is not adequate, a low water cutoff with pump control, condensate receiver, and condensate boiler feed pump should be installed.
 - See Figure 21 for piping and Figure 22 for sizing.

Figure 20 Cold water fill piping

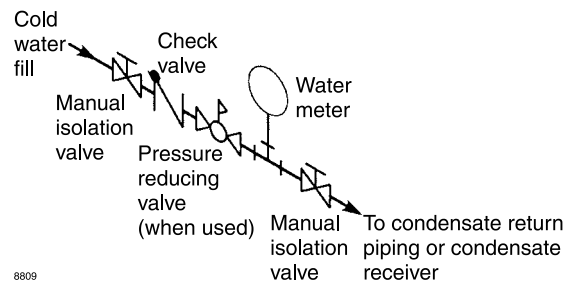

Figure 21 Condensate piping to boiler

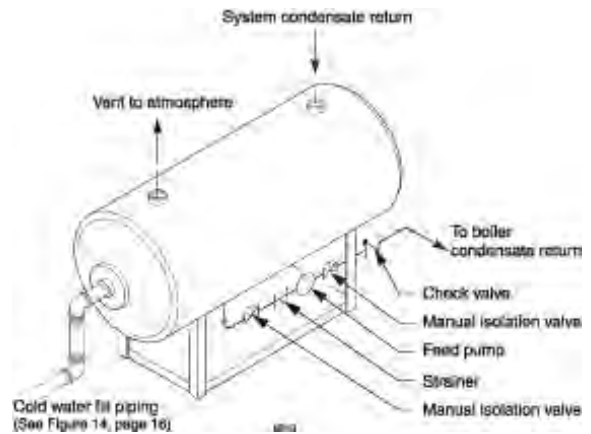

Figure 22 Condensate receiver capacity required

Boiler model number	AHRI gross output (lbs steam per hour)	Gallons condensate per hour	Minimum condensate receiver capacity (gallons) (Note 1)				Recommended condensate feed pump capacity GPM at 15 PSI
			15-minute boiler operation	30-minute boiler operation	45-minute boiler operation	60-minute boiler operation	
488	810	97	29	58	87	116	3.2
488R	794	95	28	57	85	114	3.1
588	1084	130	39	78	117	156	4.3
688	1358	163	49	98	147	196	5.4
788	1632	195	59	117	176	234	6.5
888	1904	228	68	137	205	273	7.6
988	2170	261	78	157	235	313	8.7
988R	1991	239	72	145	217	289	8.0
1088	2452	294	88	176	265	353	9.8
1088R	2304	277	83	166	249	332	9.2
1188	2724	327	98	196	294	392	10.9
1288	3000	360	108	216	324	432	12.0
1388	3270	392	117	235	353	470	13.1
1488	3550	426	127	255	383	511	14.2
1588	3820	458	137	274	412	550	15.3
1688	4090	490	147	294	441	588	16.4
1688R	3980	478	143	287	430	574	15.9
1788	4370	524	157	314	471	629	14.5
1888	4640	557	167	334	501	668	18.6

Note 1 — Maximum time to when condensate returns to boiler — the longer the time for condensate to return, the larger the receiver must be.



Connect steam boiler piping *(continued)*

CAUTION Improperly piped systems or undersized piping can contribute to erratic boiler operation and possible boiler or system damage. Piping system must be installed as shown, using pipe sizes shown. Pipe sizes shown are for two-pipe, pumped-return systems. Adjust pipe sizing as needed when connecting to gravity-return systems. Consult local Weil-McLain distributor or sales office before installing alternate piping.

Steam boiler piping guidelines

Minimum height of header above water line must be 24 inches

WARNING The boiler header must always be at least **24 inches** above the water line, as shown in all steam boiler piping diagrams. Installing the pipe lower will result in increased water carryover to the system, resulting in potential serious damage to system components and oxygen corrosion due to excess make-up water.

Hartford loop piping for all steam boilers

1. You must install the system supply pipe between the equalizer elbow and the last boiler riser pipe connection to the header. This assists in separating water from the steam as it turns upward into the steam supply pipe.
2. Locate the top of the Hartford loop return nipple at least 4 inches below the water line, as shown.

Figure 23 Model 488 through 688 steam (1 riser)

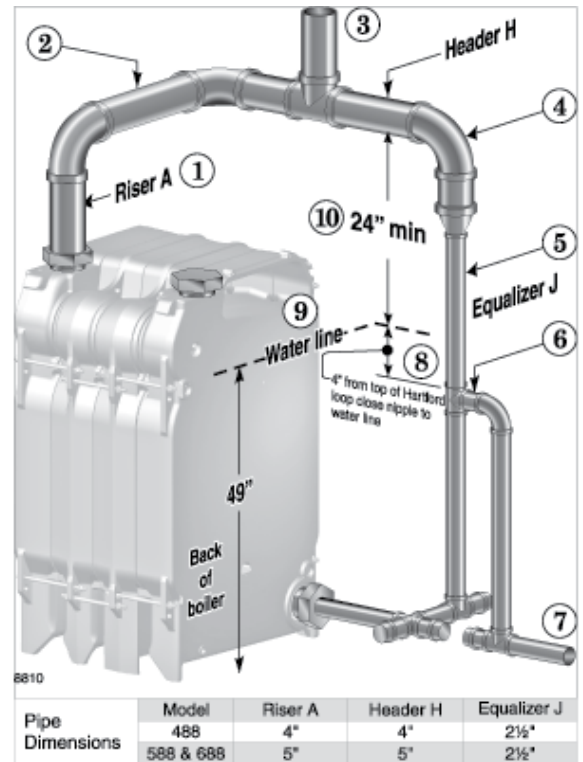

Drawing legend & notes

(Figure 23 through Figure 26)

- 1 Riser pipes (one for each supply intermediate section)
- 2 Horizontal pipes needed to offset the header to allow for expansion and contraction of the header
- 3 Steam supply must be located between last riser connection and equalizer elbow
- 4 Equalizer elbow — full size or reducing
- 5 Equalizer pipe
- 6 Close nipple at Hartford loop tee to reduce water hammer potential
- 7 Condensate return line (gravity or pumped)
- 8 Minimum 4 inches between water line and top of Hartford loop return nipple
- 9 Boiler water line — all automatic water level controls must be set to maintain this level
- 10 Minimum 24 inches between water line and bottom of header

Figure 24 Model 788 through 1188 steam (2 risers required)

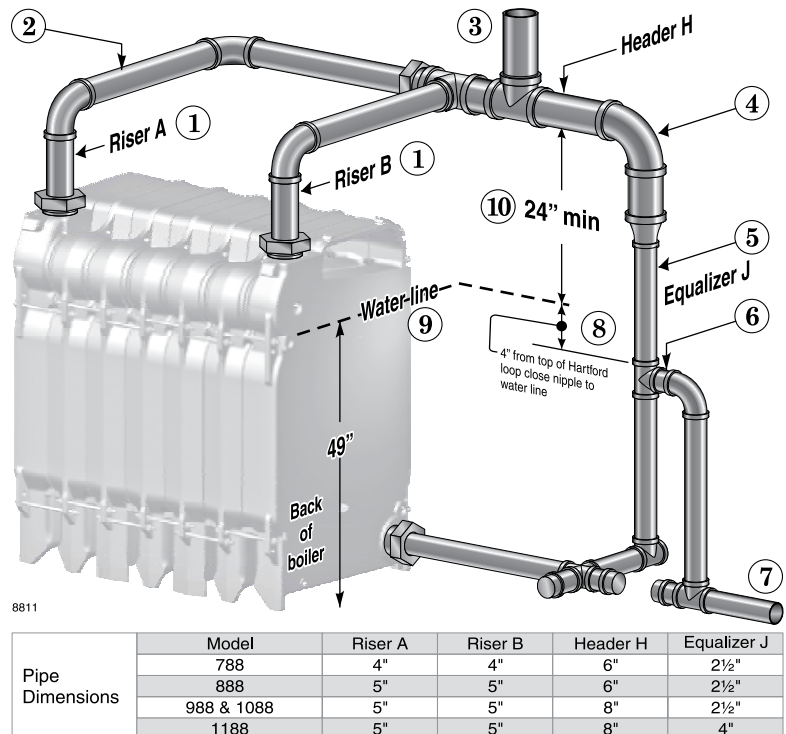

Connect steam boiler piping *(continued)*

Figure 25 Model 1288 through 1888 steam (3 or 4 risers required)

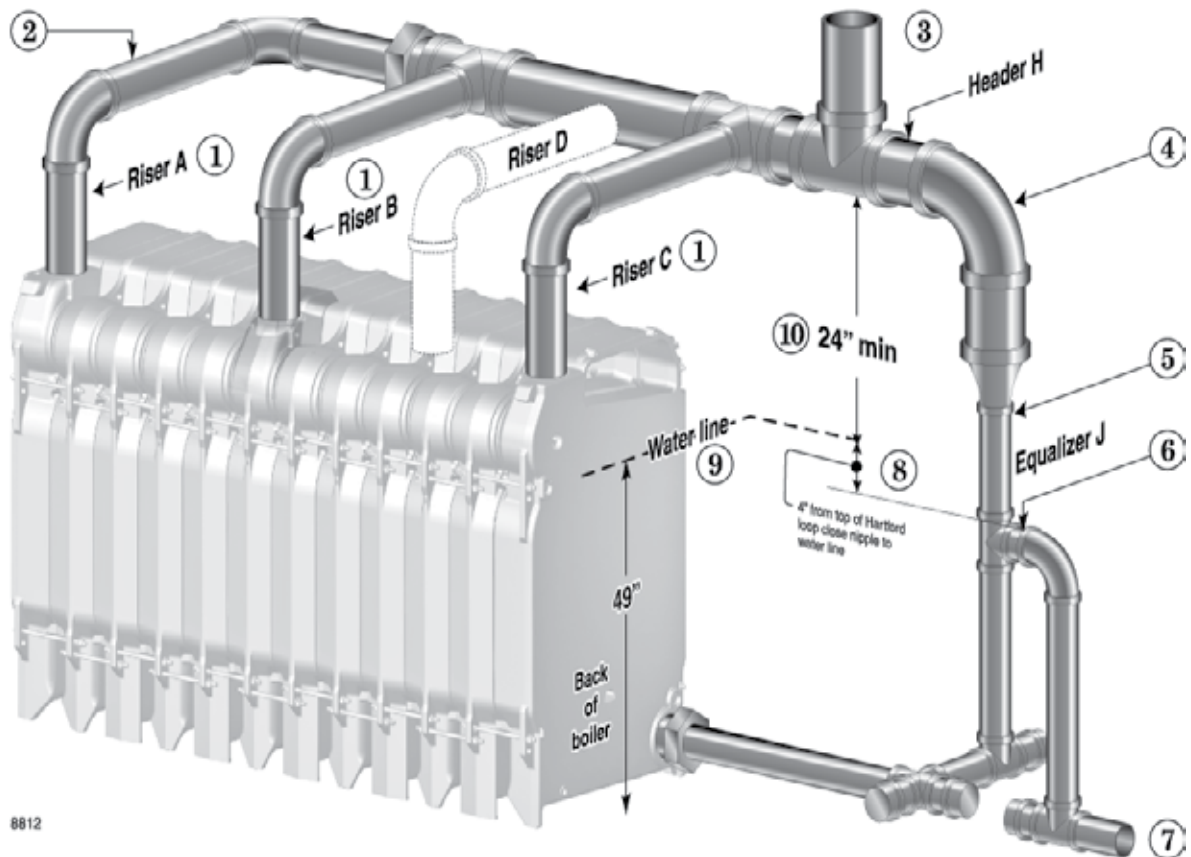

8812

	Model	Riser A	Riser B	Riser C	Riser D	Header H	Equalizer J
Pipe Dimensions	1288 – 1488	5"	5"	5"	NA	8"	4"
	1588 – 1688	5"	5"	5"	NA	10"	4"
	1788 – 1888	5"	5"	5"	5"	10"	4"

Drawing legend & notes

(Figure 23 through Figure 26)

- 1 Riser pipes (one for each supply intermediate section)
- 2 Horizontal pipes needed to offset the header to allow for expansion and contraction of the header
- 3 Steam supply must be located between last riser connection and equalizer elbow
- 4 Equalizer elbow — full size or reducing
- 5 Equalizer pipe
- 6 Close nipple at Hartford loop tee to reduce water hammer potential
- 7 Condensate return line (gravity or pumped)
- 8 Minimum 4 inches between water line and top of Hartford loop return nipple
- 9 Boiler water line — all automatic water level controls must be set to maintain this level
- 10 Minimum 24 inches between water line and bottom of header

Connect steam boiler piping *(continued)*

Figure 26 Multiple Steam Boiler Piping Gravity Condensate Return

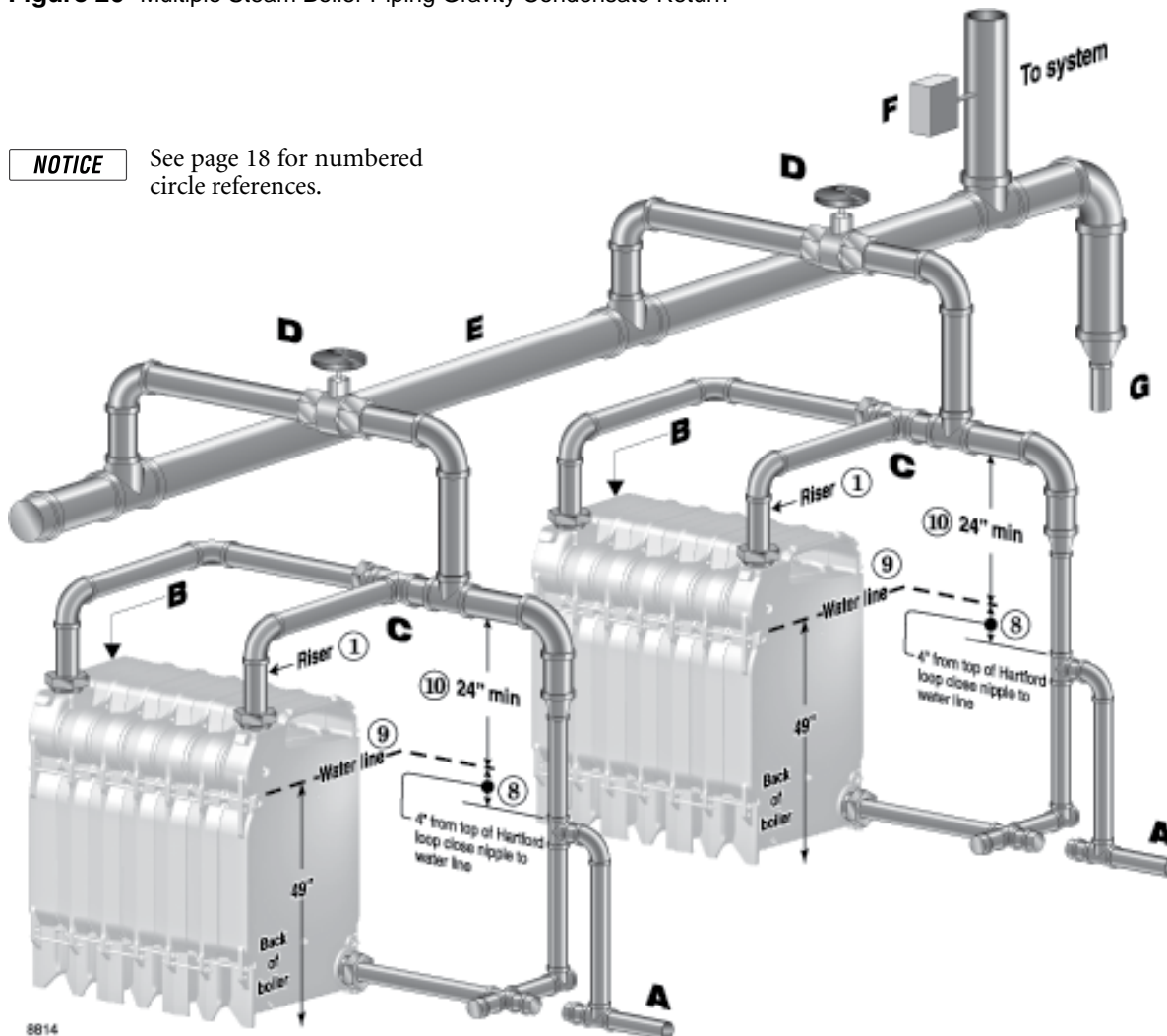

- A** Pipe as shown for gravity return systems, connecting point **A** to the wet gravity return.
- For pumped-return systems, install boiler water level control on each boiler with body mark at level indicated in Figure 42, page 28. Provide at point **A** either:
 - Separate feed pumps and check valves for each boiler, or . . .
 - Single feed pump, with separate solenoid valve for each boiler.
- B** For pumped-return systems, install a combination float and thermostatic trap on each boiler to prevent flooding of one boiler while other boiler is firing. Install trap in skim tapping (see Figure 39, page 27). Connect traps to condensate receiver.
- Gravity-return systems are self-levelling if the wet returns are piped to the common system wet return.
- C** Install boiler piping as shown in the preceding pages of this manual.
- D** Install stop valves per ASME code requirements.
- For pump-return systems, if using automatic steam valves, use only slow-opening automatic valves. Use a Weil-McLain Boiler Control System (such as a BCP panel) to open each steam valve automatically before firing burner.
- E** Construct common supply drop header with pipe size at least same size as largest boiler header size.
- F** Use:
- A Weil-McLain Boiler Control System (such as a BCP panel) with header-mounted pressure control(s) to sequence boilers, or . . .
 - A steam pressure controller.
- G** Install drip line in common supply drop header.
- Gravity-return: Pipe drip line to wet return.
 - Pumped-return: Use combination float and thermostatic trap and drain to condensate receiver.



Install jacket

Before installing jacket

WARNING The boiler contains ceramic fiber and fiberglass materials. Use care when handling these materials per instructions on page 34 of this manual. Failure to comply could result in severe personal injury.

- These parts **must be on boiler**:
 - Plugs for unused tapings
 - Supply and return piping and steam supply header
 - Cleanout plates
 - Tankless heaters (when used), tankless heater cover plates (when used), tankless heater piping (when used)
 - Flue damper assembly
 - Observation port assemblies
- These parts **may be on boiler**:
 - Burner mounting plate
- These parts **must be off boiler**:
 - Water or steam gauge
 - Limit control and low water cutoff
 - Gauge glass and gauge glass cocks, tri-cocks
 - Drain cock

Remove jacket parts from cartons

- Locate jacket cartons.
- Remove jacket parts from cartons as needed. Leave in cartons as long as possible to avoid damage.
- Jacket parts are in the boxes listed below:

Part	Box label descriptions
Jacket screws (in jacket corner boxes)	included in CRNR boxes
Jacket support brackets & hex nuts	BKT
Jacket side support channels, upper & lower	included in TRM/CHNL boxes
Jacket front/rear support channels, upper & lower	COM
Jacket front panel	PNL-F
Jacket back panel	PNL-B
Jacket side and top panels	L / R / T
Jacket corners	CRNR
Jacket trim	TRM/CHNL

Install support brackets/channels

- Place upper and lower support brackets over draw rods as shown in Figure 29, page 21. Place the brackets on the sections as given in Figure 27. Sections are numbered from front to back.
- Fasten each bracket loosely using two 5/8" nuts screwed onto the ends of the tie rods as shown.

NOTICE Models 488 through 988 do not require lower support brackets. Only upper brackets are required.

Fasten all nuts and screws loosely during assembly to allow adjustment after all jacket frame parts are installed.

Figure 27 Place support brackets as listed below

Boiler	Upper brackets on sections:	Lower brackets on sections:
488	2, 3	None
588	2, 4	None
688	2, 5	None
788	2, 6	None
888	3, 6	None
988	2, 5, 8	None
1088	3, 6, 9	6
1188	3, 6, 9	6
1288	3, 7, 10	7
1388	3, 7, 11	7
1488	3, 7, 10, 13	7
1588	2, 5, 8, 11, 14	8
1688	2, 5, 9, 12, 15	9
1788	2, 5, 9, 13, 16	9
1888	2, 6, 10, 14, 17	10

- Attach the upper channels to the upper supports as shown in callouts ①, ② and ⑥, Figure 29, page 21. Use two #10 x 1/2" screws at each bracket. Models 988 and larger have two-piece channels.
 - The side channels are labelled **A** and **B** in Figure 29. Figure 28 gives the lengths of the side channel parts for each model.
 - The channels at the boiler front and rear are part numbers 426400030 & 426400031, respectively.

Figure 28 Upper and lower side channel lengths

Boiler	Upper channel lengths (inches)		Lower channel lengths (inches)	
	A	B	A	B
488	30	NA	26	NA
588	38	NA	34	NA
688	46	NA	42	NA
788	54	NA	50	NA
888	62	NA	58	NA
988	35	35	66	NA
1088	43	35	40	34
1188	43	43	40	42
1288	51	43	48	42
1388	51	51	48	50
1488	51	59	48	58
1588	59	59	56	58
1688	67	59	64	58
1788	67	67	64	66
1888	71	71	72	66

- Attach the four jacket corners to the upper channels as shown in callout ⑥, Figure 29, page 21. Corner part numbers are: 426400054 (front left), 055 (front right), 056 (back left), and 057 (back right).
- Attach the lower side, front and rear channels to the jacket corners as shown in callouts ④ and ⑤ of Figure 29, page 21. Models 1088 and larger have two-piece side channels. The channels are labelled **A** and **B** in Figure 29. Figure 28 gives the lengths of these parts for each model. Front and rear lower channels are part numbers 426400032 and 426400033.



Install jacket *(continued)*

Figure 29 Installing jacket support brackets, support channels and corners *(piping and other components omitted for clarity)*

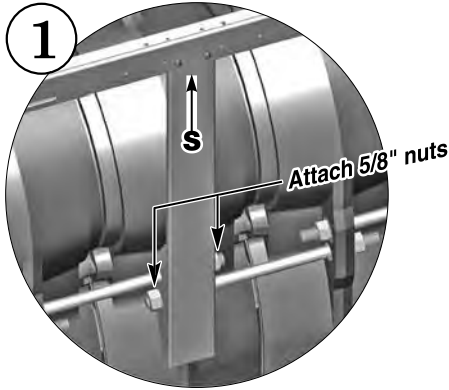

Upper right support bracket

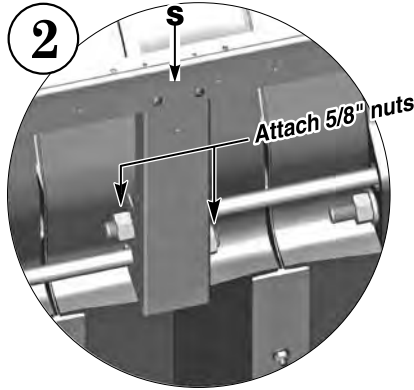

Upper left support bracket

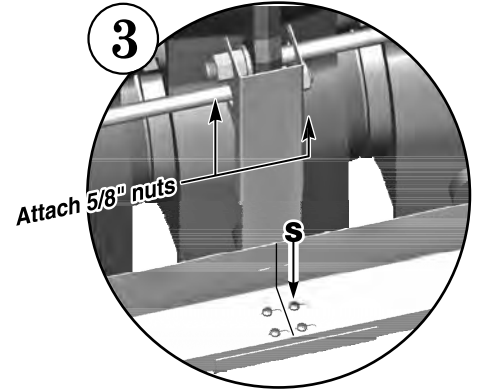

Lower support brackets

S = Insert #10 x 1/2" Phillips pan head screws
A, B = Side channel pieces, front and rear

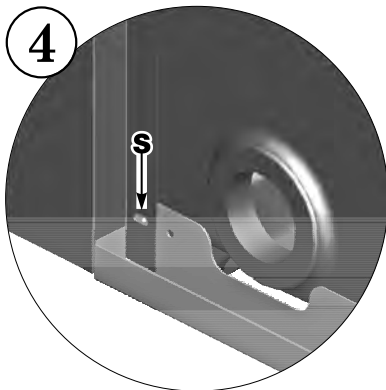
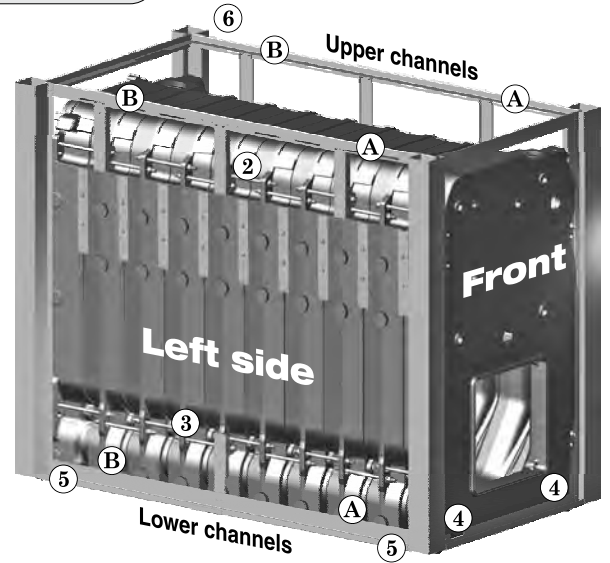
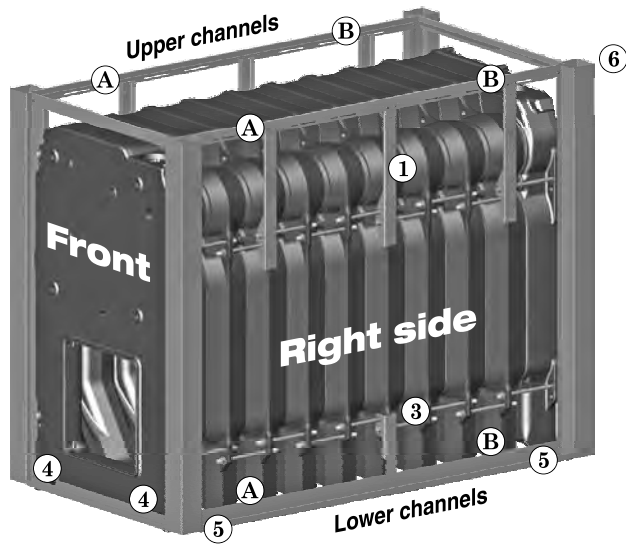

Corner attachments to lower front and rear channels

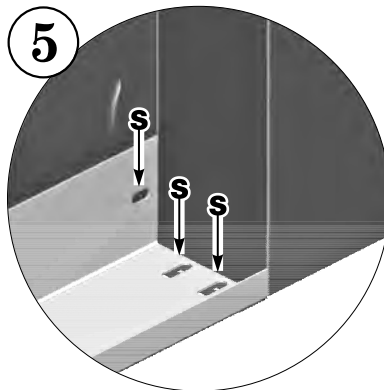

Corner attachments to lower channels

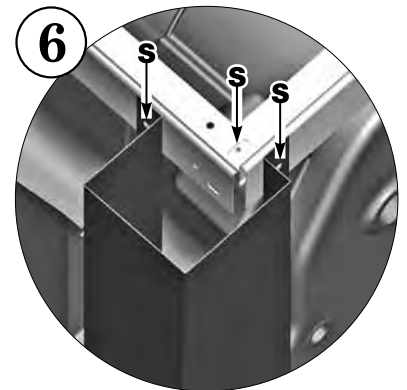

Corner attachments to upper channels



Install jacket *(continued)*

Install jacket front and back panels

1. Slide the jacket front and back panels down over the top channels and into the bottom channels as shown in Figure 30.
2. Slide the upper and lower channels as needed to square up the fit.

Install jacket side panels

1. Remove jacket side panels from cartons.
2. Before installing side panels, square up the jacket support rails.
 - Place any of the jacket side panels on the rails as shown in Figure 30.
 - Butt the side panel against the jacket corner panel.
 - Push/pull on the upper and lower channels until the fit-up of the side panel, corner panel and channels is square.
 - Place a jacket top panel in position against the jacket front panel to ensure the top alignment is square. Adjust the jacket support rails forward or backward if needed for square alignment.
 - Tighten the 5/8-inch nuts on the upper (and lower) support brackets.
 - Tighten the screws securing the upper and lower rails to the support brackets.
 - Tighten the screws securing the front and back panels to the rails.
3. Apply all jacket side panels in the order shown in Figure 32.
 - Remove jacket knockouts as required for tankless heaters and tankless heater openings.
 - Note that panel sequence is not important for boilers not equipped with tankless heater intermediate sections.

Install jacket top panels

1. Place jacket top panels as shown in Figure 33, page 24.
 - Remove knockouts for riser pipes and air bleed piping (front section) using tin snips.

Install jacket trim

2. Press jacket trim down over the front and side jacket panels as shown in Figure 31.

Figure 30 Installing (removing) jacket front, rear and side panels

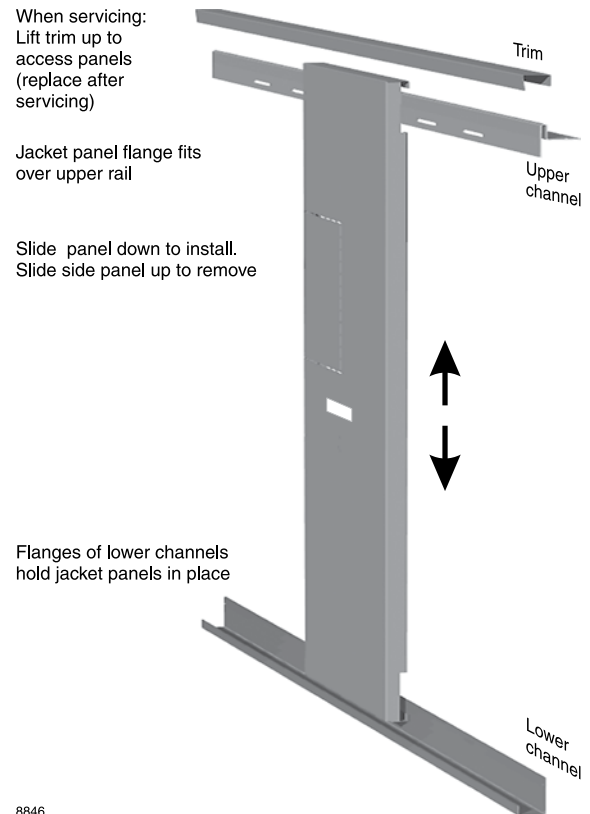
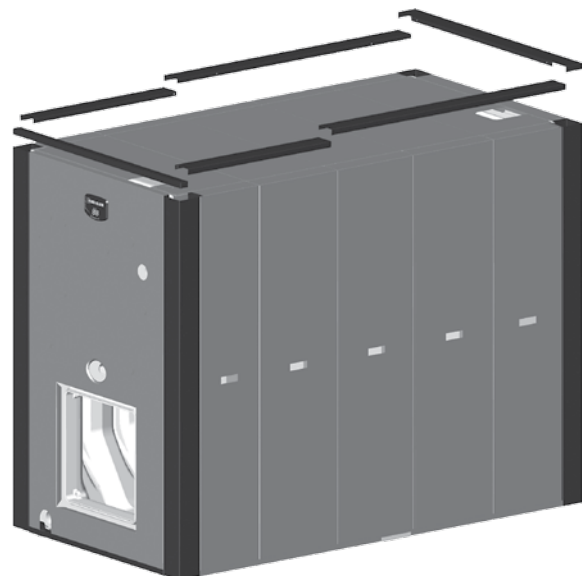

Figure 31 Press jacket trim down over jacket front, rear and side panels





Install jacket *(continued)*

Figure 32 Jacket side panel placement

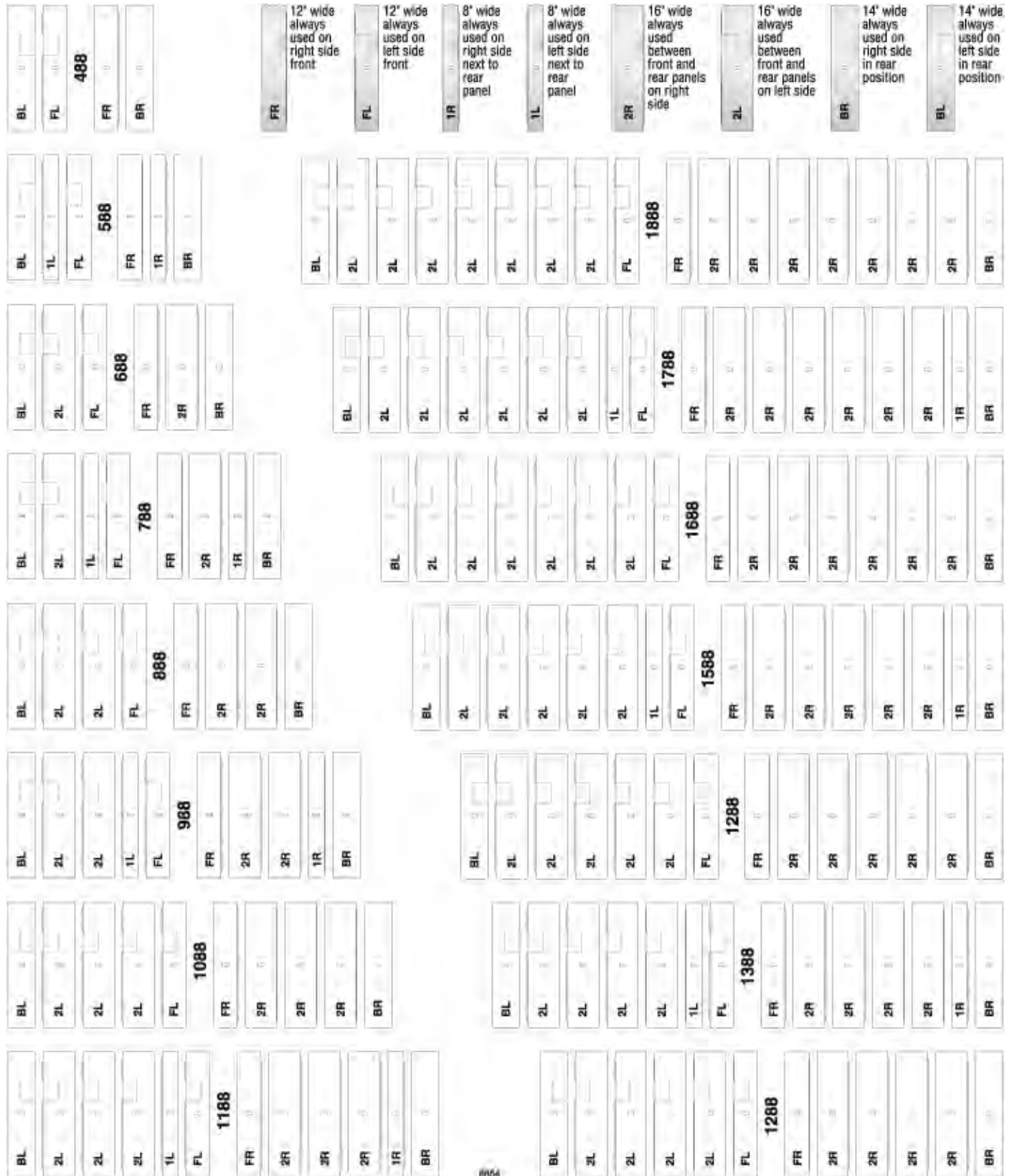



Install jacket *(continued)*

Figure 33 Jacket top panel placement

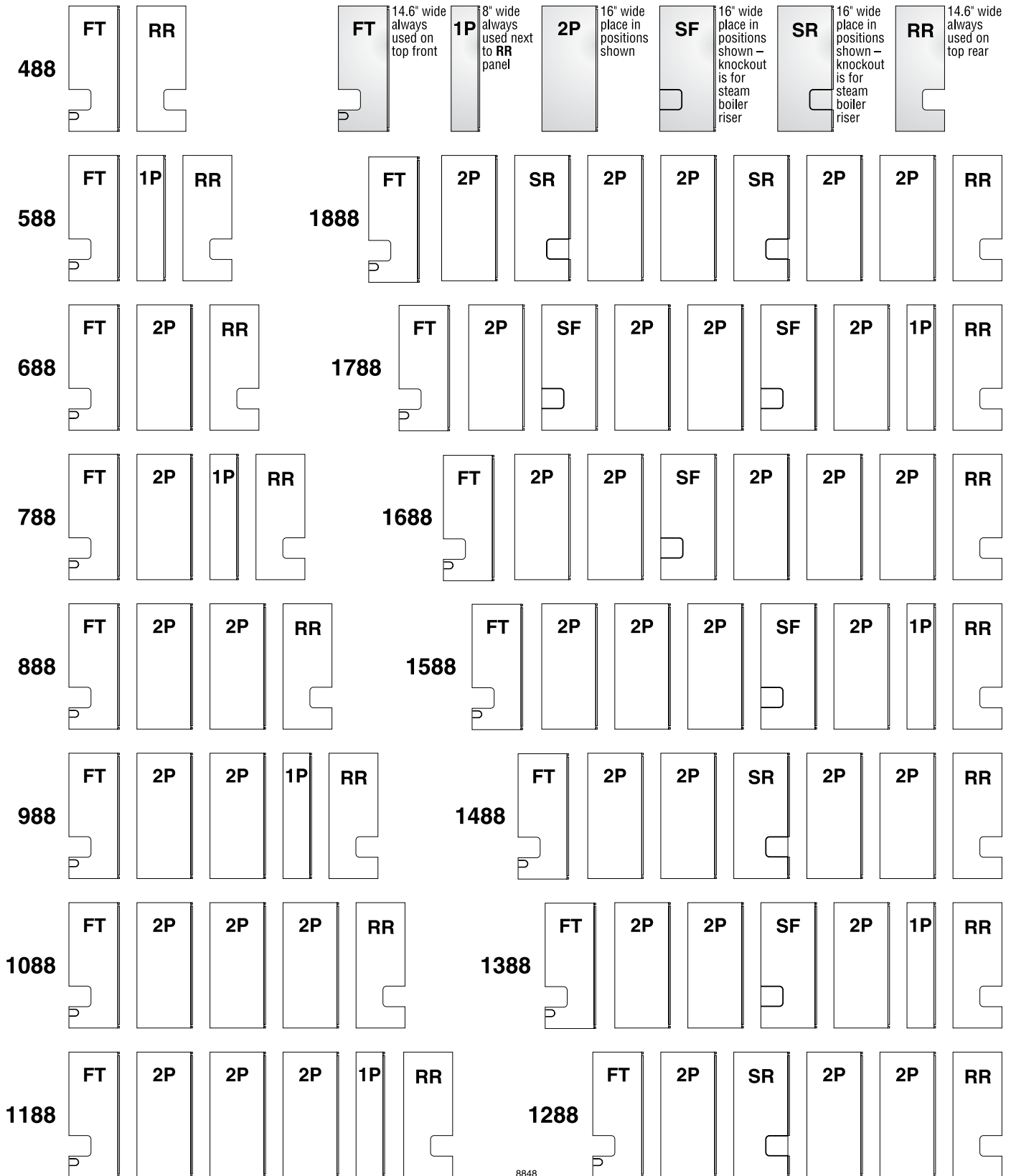

8848

Pipe tankless heaters

⚠ DANGER Hot water can scald!



Consumer Product Safety Commission and some states recommend domestic hot water temperature of 130°F or less.

When installing an automatic mixing valve, selection and installation **must** comply with valve manufacturer's recommendations and instructions.

Water heated to a temperature suitable for clothes washing, dish washing and other sanitizing needs will scald and cause injury.

Children, elderly, infirm or physically handicapped persons are more likely to be injured by hot water. Never leave them unattended in or near a bathtub, shower or sink. Never allow small children to use a hot water faucet or draw their own bath. If anyone using hot water in the building fits this description, or if state laws or local codes require certain water temperatures at hot water faucets, take special precautions:

- Install automatic mixing valve set according to those standards.
- Use lowest practical temperature setting.
- Check water temperature immediately after first heating cycle and after any adjustment.

To pipe tankless heaters:

1. See Figure 35.
2. Size piping no smaller than heater inlet and outlet.
3. Automatic mixing valve must be installed. See Figure 35. Follow manufacturer's instructions to install.
4. Flow regulating valve must be installed. Size according to continuous draw of heater. See Figure 34. Follow manufacturer's instructions to install.
5. Operating control with small adjustable differential scale is recommended. Install in temperature control tapping in heater plate.
6. Multiple tankless heaters (see Figure 35):
 - a. Use cold water supply header with individual risers to each heater. Size header by increasing one pipe size for each additional heater.
 - b. Use hot water outlet header with individual risers to each heater. Size header by increasing one pipe size for each additional heater.
 - c. Do not pipe multiple heaters in series.
7. In hard water areas, soften cold domestic water supply to heaters to prevent lime build-up.

Figure 34 Tankless heater ratings (Weil-McLain ratings)

Heater number	Intermittent draw – GPM (note 2)	Continuous draw GPM (notes 1, 2)	Inlet and outlet tapings
820	8.5	8.0	¾"
Note 1	GPM based on 40–140°F DHW with boiler water at 200°F		
Note 2	Based on continuous draw with no recovery period		

Figure 35 Tankless Heater Piping

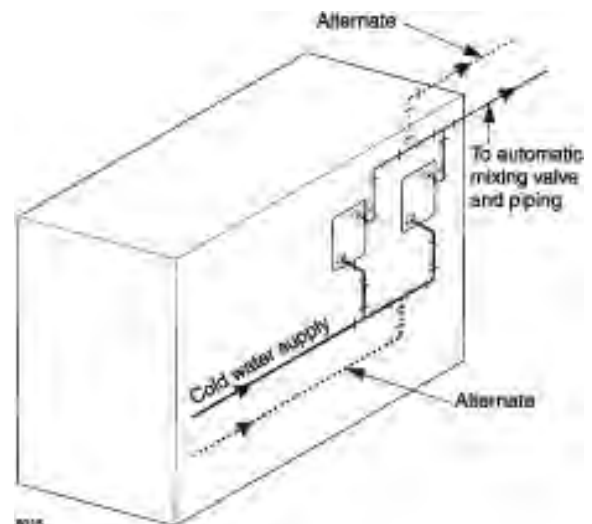



Install water boiler controls

Install controls:

1. Install furnished controls per Figure 37 and Figure 36.

WARNING Failure to properly install, pipe and wire boiler controls can result in severe damage to boiler, building and personnel; and is not covered by boiler warranty.

2. Relief valve must be installed with spindle in vertical position. Use fittings provided with boiler. Do not make any other connection in that piping.

WARNING Relief valve discharge line must be piped using rigid material suitable for 375°F, threaded one end, near floor close to drain to eliminate potential of severe burns. Do not pipe to any area where freezing could occur. Do not plug, valve or place any obstruction in discharge line.

3. When installing low water cut-off
 - a. Must be installed if boiler is located above radiation level.
 - b. May be required on water boilers by certain state, local or territorial codes or insurance companies.
 - c. Install low water cutoff designed for water installations where shown in Figure 37 and Figure 36.
4. If installation is to comply with ASME installation requirements, an additional high temperature limit is needed. Purchase and install in supply line between boiler and isolation valve or in tapping "A."
5. Dual limit control settings:
 - a. **Low** – set according to design requirements.
 - b. **High** – at least 20° higher than low limit, 240°F maximum.
6. Install optional controls per control manufacturer's instructions.

Figure 37 Water control tappings (see Figure 36)

Location	Size	Function
A	2"	High limit Manual reset limit
B	2"	Water relief valve
L	1"	Not used — plug
C1 & C2	1"	Alternate low water cut-offs
C1		Combination high and low limit control
D1 & D2	1"	Firing rate temperature control (when used) Low water cut-offs
E1 & E2	½"	—
F1 & F2	⅜"	—
G	¾"	Combination pressure–temperature gauge
H	¾"	Boiler drain
K	1"	Piping to compression tank or automatic air vent
M	2"	Drain

Figure 36 Water control locations

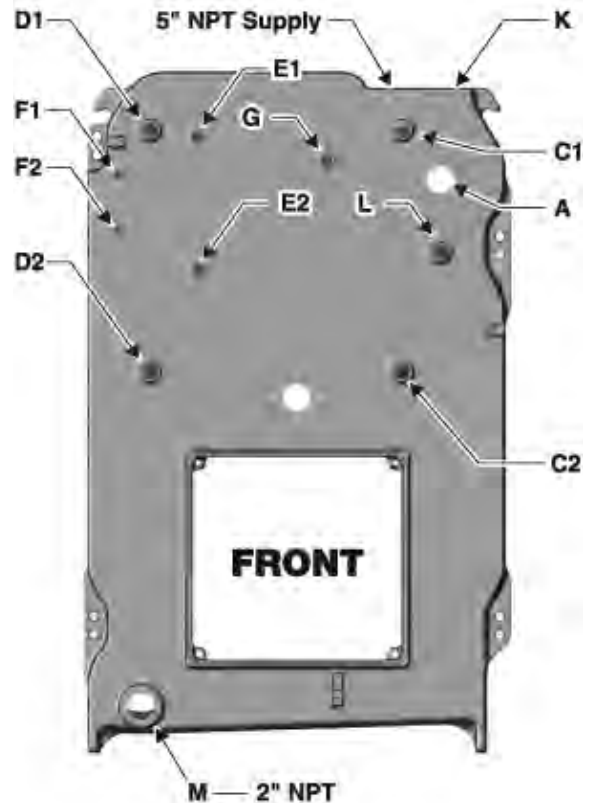



Install steam boiler controls

Install controls:

1. Install controls where shown in Figure 38 and Figure 39.

WARNING Failure to properly install, pipe and wire boiler controls can result in severe damage to boiler, building and personnel; and is not covered by boiler warranty.

- a. Install steam pressure operating and high limit controls and pressure gauge. See Figure 38, Figure 39 and Figure 40, page 28. Pressure limit control settings:
 - **Low** – set according to design requirements.
 - **High** – set at least 2 psi higher than low limit, 15 psi maximum.
- b. Relief valve must be installed with spindle in vertical position. Use fittings provided with boiler. Do not make any other connection in that piping.

WARNING Pipe relief valve discharge through vertical piping to atmosphere. Use rigid material suitable for 375°F, threaded one end only. Install drain pan elbow to drain condensate. Pipe near floor close to floor drain to eliminate potential of severe burns. Do not pipe to any area where freezing could occur. Do not plug, valve or place any obstruction in discharge line.

- c. Install water level controls and gauge glass per Figure 38, Figure 39 and Figure 42, page 28.
 - Fittings for controls to be furnished by others.
 - If water level control is not shown in Figure 41, page 28, locate casting mark on control and install per manufacturer's instructions.

NOTICE Do not use water level controls with quick hook-up fittings. Nuisance shutdowns will occur.

Figure 39 Steam control locations

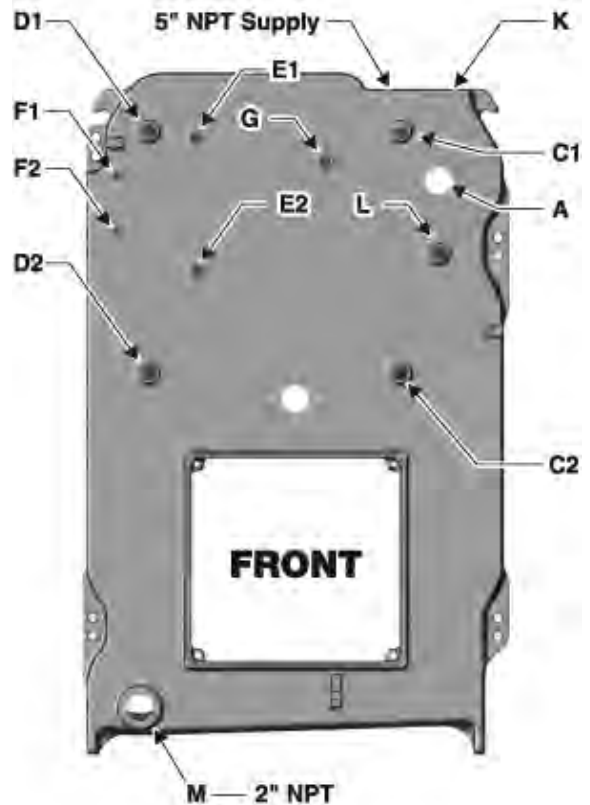

Figure 38 Steam control tappings (see Figure 39)

Location	Size	Function
A	2"	Steam relief valve and/or Skim tapping
B	2"	Steam relief valve
L	1"	Secondary probe low water cut-off
C1 & C2	1"	Low water cut-offs (see Figure 42, page 28)
C1	—	—
D1 & D2	1"	Alternate low water cut-offs (see Figure 42, page 28)
E1 & E2	½"	Gauge glass
F1 & F2	⅜"	Try cock tappings
G	¾"	Pressure limit control, Pressure operating control and pressure gauge, Firing rate pressure control (when used)
H	¾"	Boiler drain (see Figure 17, page 15, for system blow-off (drain) valve locations and sizes)
K	1"	—
M	2"	Blowdown/drain



Install steam boiler controls *(continued)*

Figure 40 Steam control siphon and fittings

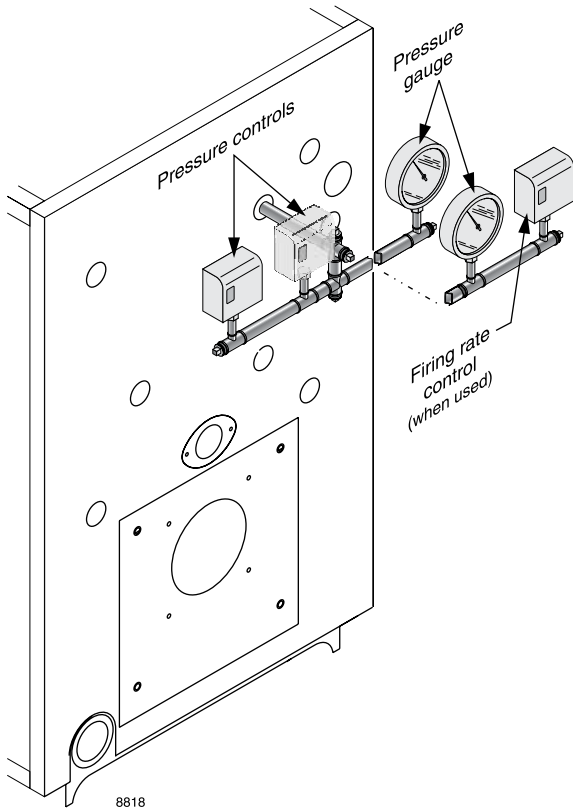

Figure 41 Float-type water level control locations

Primary water level control	Casting line height above bottom of gauge glass	Back-up water level control	Casting line height above bottom of gauge glass
Note 1	"A"	Notes 1, 2	"B"
61, 63	¼"	None	—
	1½"	61, 63	½"
150MD, 157MD (see Note 3)	2⅜"	None	—
	2"	150	¼"
	2⅜"	61, 63	¼"
	2⅜"	51-2 & 51-S-2	¼"
93, 193, 94 (see Note 3)	2"	None	—
	2"	93, 193, 94	¼"
	2"	61, 63	¼"
	2"	51-2 & 51-S-2	¼"
51-2 & 51-S-2 (see Note 3)	1" to 1¼"	None	—

Notes:

1. Other manufacturer's controls providing similar function may be used, if properly located and selected.
2. Use low water cut-off function only. Pump controller function must only be handled by the primary control.
3. When pump control is used with feedwater tank, install pump control on boiler and make-up water feeder on tank. Use separate low water cutoff on boiler when back-up is needed. Do not install combination low water cutoff and feeder as back-up control on boiler. Feeder will operate before pump control operates.

Figure 42 Water level control locations (see Figure 41)

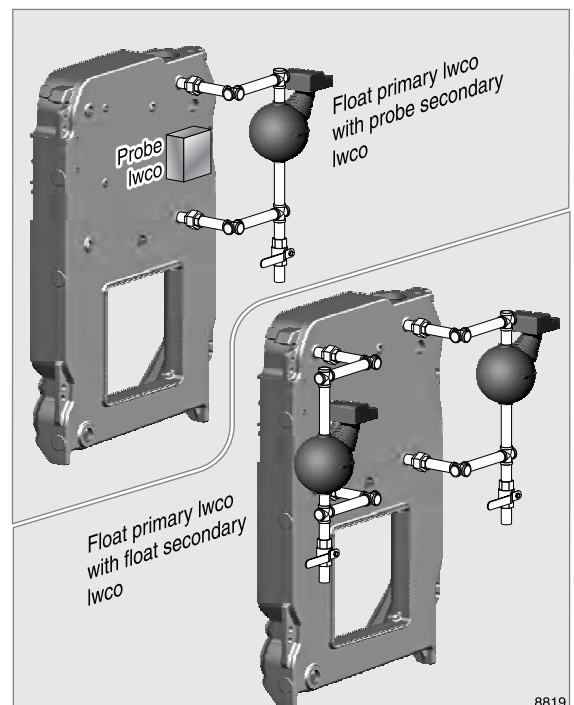
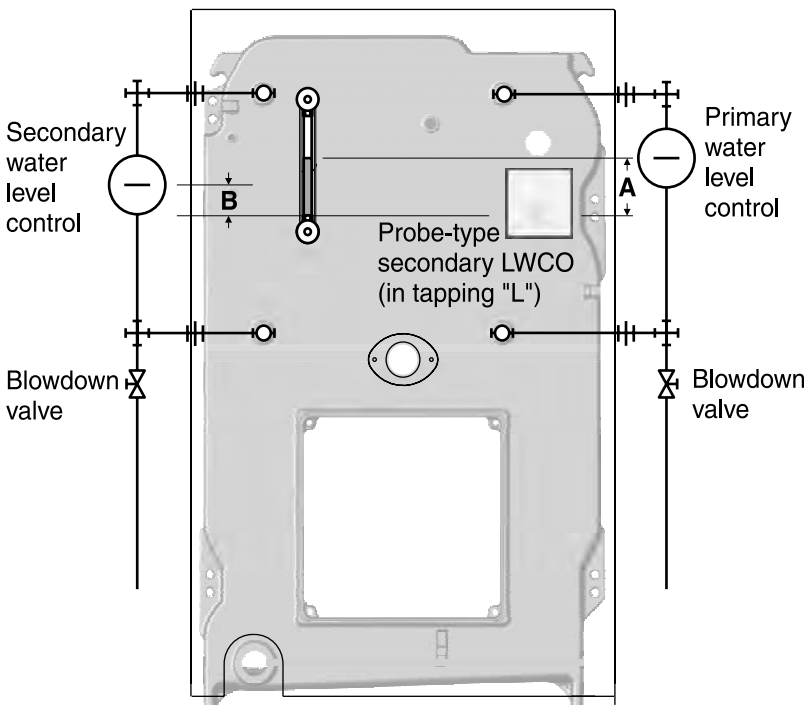



Connect breeching and venting systems

General venting information

1. Model 88 boilers operate with positive overfire pressure. Adjust damper assembly (see Figure 49, page 33) during burner start-up to achieve 0.1" W.C. positive pressure at damper sample hole.

Select type of venting system

Forced draft

- Boiler, breeching and stub vent operate at positive pressure. Entire system must be gas-tight to prevent leaks. Stub vent height must be limited to prevent negative draft with 3-foot minimum stub vent height above roof. See Figure 44 and Figure 46.

Balanced draft

- Boiler operates with positive pressure overfire. Chimney **may** provide excess draft which may require a barometric draft control installed and set to provide minimum draft to maintain 0.1" positive pressure at flue collar. Minimum chimney height above roof is 3 feet. See Figure 45 and Figure 47.

Construct metal breeching:

1. See Figure 43 for minimum breeching diameter.
2. Select material type and thickness in compliance with local codes.

⚠ WARNING Conventional flue pipe should not be used as it could leak flue gases and carbon monoxide emissions through seams and joints, resulting in severe personal injury or death.

3. Refer to ASHRAE Guide for chimney and breeching calculations and construction and lining.

⚠ WARNING Long horizontal breechings, excessive number of tees and elbows or other obstructions restricting combustion gas flow can result in possibility of condensation, flue gas leakage and carbon monoxide emissions, causing severe personal injury or death.

Figure 43 Minimum breeching diameter

Boiler model	AHRI vent or liner diameter (inches)		Boiler flue collar dimensions (inches)
	Forced draft	Balanced draft	
488	10	12	10 round
588	10	15	10 round
688	12	15	10 round
788	12	18	12 round
888	14	18	12 round
988	14	18	14 round
1088	14	21	14 round
1188	16	21	14 round
1288	16	21	14 round
1388	16	24	14 round
1488	18	24	16 round
1588	18	24	16 round
1688	18	24	16 round
1788	18	24	16½ x 19½ oval
1888	20	27	16½ x 19½ oval



Connect breeching and venting systems

Figure 44 Stub vent – forced draft — single boiler

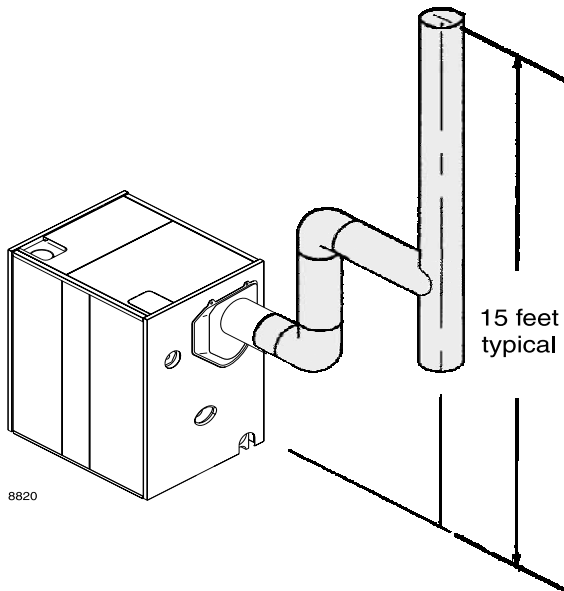

Figure 46 Stub vent – forced draft — multiple boilers

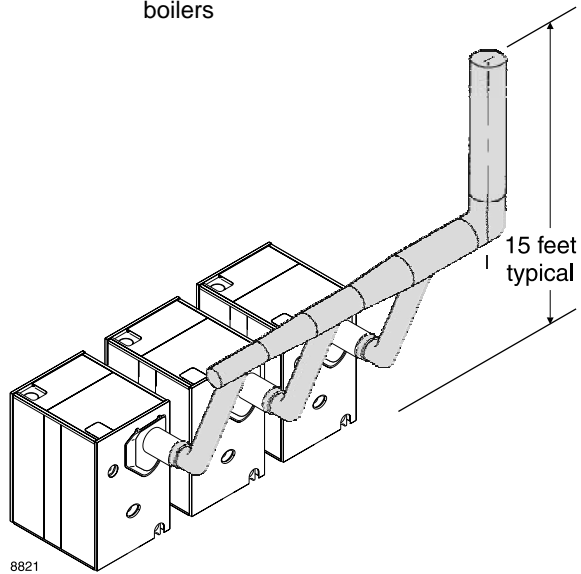

Figure 45 Conventional chimney – balanced draft with barometric draft control when required — single boiler

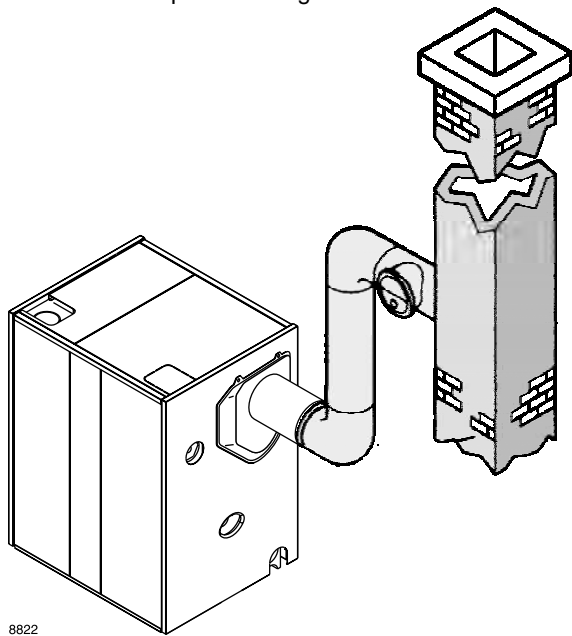
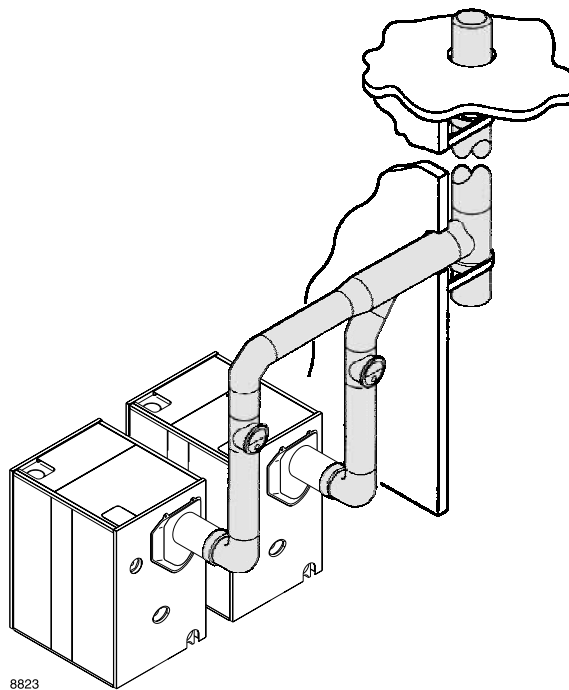

Figure 47 Conventional chimney – balanced draft with barometric draft control when required — multiple boilers





Install burner & wiring and fill system

To install burner

1. Unpack burner.
2. Place gasket around air tube and against burner mounting flange. If sealing rope is used, apply $\frac{1}{8}$ " continuous bead of rope adhesive around burner mounting flange and apply sealing rope to make gas-tight seal.
3. Mount burner into opening in burner mounting plate.

CAUTION Maintain gas-tight seal between burner mounting flange and plate to prevent damage to air tube.

4. Level burner using burner support brackets where required.
5. Secure with furnished bolts.
6. Retain burner information packet. Keep with boiler.

To wire burner and boiler controls

WARNING Electric shock hazard. Can cause severe personal injury or death if power source is not disconnected before installing or servicing boiler and burner.

1. Install all wiring in compliance with:
 - National Electrical Code ANSI/NFPA 70.
 - Any additional national, state, or local codes.
2. Follow burner manual and wiring diagram found in burner information packet.
3. Use #14 AWG wire for operating and safety circuit wiring.
4. Where burner motor voltage differs from control voltage, supply proper voltage to each. Size fused disconnects and conductors per National Electrical Code ANSI/NFPA 70.

Determine if water treatment is needed (water boilers only)

WARNING Do not use petroleum-based cleaning or sealing compounds in boiler system. Severe damage to system components can result, causing substantial property damage.

Continual make-up water will reduce boiler life. Minerals can build up in sections, reducing heat transfer, overheating cast iron and causing section failure.

For unusually hard water areas or low pH conditions (less than 7.0) consult local water treatment company. Provide a water softener for make-up water if hardness exceeds 7 grains.

Freeze protection (when used) (water boilers only)

1. Use antifreeze especially made for hydronic systems. Inhibited propylene glycol is recommended.

WARNING Do not use automotive, ethylene glycol or undiluted antifreeze. Severe personal injury or death can result.

2. 50% solution provides protection to about -30°F.
3. Local codes may require back-flow preventer or actual disconnect from city water supply.
4. Determine quantity according to system water content. Boiler water content is listed in "Ratings," page 35. Percent of solution will affect sizing of heat distribution units, circulator and expansion tank.
5. Follow antifreeze manufacturer's instructions.

To fill water boilers

1. Close manual air vents and drain cocks.
2. Fill to correct system pressure. Correct pressure will vary with each installation.
3. Starting on lowest floor, open air vents one at a time until water squirts out. Close vent. Repeat with remaining vents.
4. Refill boiler to correct pressure.

To fill steam boilers

1. Do not fill (except for leakage test) until boiler is ready to be fired.
2. Fill to normal waterline, halfway up gauge glass.
3. Recommend boiler water pH 7.0 to 8.5.



Install fuel piping

Gas piping

- In sizing the gas piping, the following factors should be considered:
 - Diameter and length of the gas supply piping.
 - Number of fittings.
 - Maximum gas consumption (including any possible future expansion).
 - Allowable loss in gas pressure from the gas meter outlet to the boiler.
- Minimum inlet natural gas pressure required at manual main shut-off valve — see the burner manual and material list.
- Follow good piping practices.
- Pipe joint compound (pipe dope) must be resistant to the corrosive action of liquefied petroleum gases and applied sparingly only to the male threads of pipe joints.
- A ground joint union must be installed in the piping to provide for servicing. The supply piping must include a manual shut-off valve and sediment trap. See Figure 48.
- Piping must be supported by hangers, not by the burner or its accessories.
- Purge all air from the supply piping.
- All gas piping must be tested for leaks after installation. Use soap suds mixture only.

Fuel oil piping

⚠ DANGER To prevent oil flow in case of oil line breakage:

- Use anti-syphon device when any part of the oil tank is above burner level.
- Use check valve in suction line on burner side of manual shut-off valve nearest tank when top of fuel oil tank is below burner level.

Failure to comply could result in fuel leakage or fire, causing potential severe personal injury, death or substantial property damage.

- A two-pipe fuel oil piping system is required for all installations.
- Supply and return lines must enter tank from top, extending to within 4 to 6 inches from bottom of tank.
- Use oil filter sized for fuel pump suction gear capacity.
- Install oil filter.

⚠ CAUTION Do not install filter outside or close to an outside wall.

- Use continuous copper tubing to reduce possible piping leaks and to ensure reliable seal when oil piping is buried.
- Use flare fittings, not compression fittings.

⚠ DANGER **Fire hazard** — DO NOT USE soldered fittings. No safe repair can be made.

Figure 48 Gas supply piping

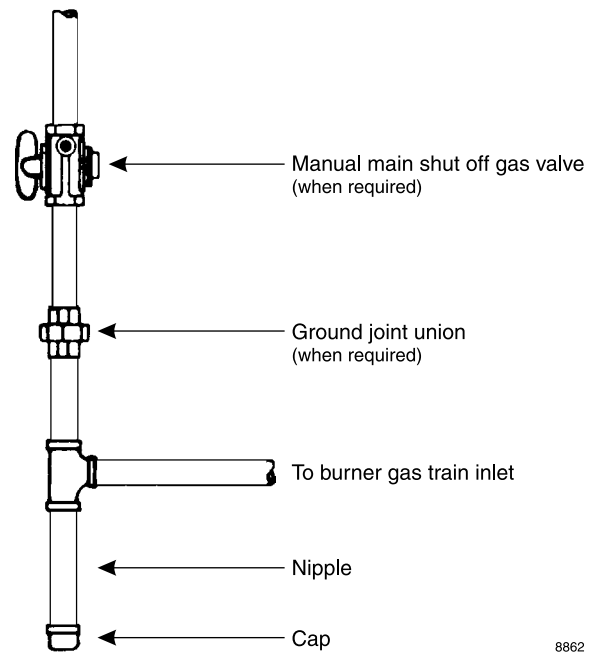

8862

- Follow good piping practices.
- Pipe joint compound (pipe dope) must be resistant to corrosive action of fuel oil. Apply sparingly only to male threads of pipe joints.
- Supply and return piping should be sized to design conditions, but not less than ½" O.D. continuous copper tubing.
- Auxiliary fuel oil pump is recommended when suction line lift exceeds 12 feet.
- Install swing joints so they will tighten as buried tank settles to prevent fuel line breakage.
- Where iron pipe is required by local codes, make swing joints with nipples and elbows several inches long on both suction and return line. Locate close to tank.
- Install manual shut-off valve in suction line piping near burner and where piping enters building from outside tank.
- Pitch suction line piping toward fuel tank.
- Provide tee and plug at highest point in suction line to release air from suction line and aid in priming.

Make final adjustments

Adjust burner and damper assembly:

1. Lock flue damper OPEN (Figure 49).

WARNING Make final burner adjustments using combustion test equipment to assure proper operation. Do not fire boiler without water. Sections will overheat, damaging boiler and resulting in severe property damage.

2. Refer to burner manual for start-up and service.
3. Let burner advance to high fire. Heat boiler to design conditions.
4. Using combustion test equipment, adjust burner for:
 - a. 12% ($\pm 1/4\%$) CO₂ for No. 2 fuel oil, 0 smoke.
 - b. 9 – 10% CO₂ natural gas; CO in flue gas not to exceed 50 ppm (0.01%).
 - c. **Flue gas temperature no lower than 330°F.**

NOTICE On some applications, if draft conditions or burner characteristics cause the burner flame pattern to impinge on the combustion chamber wall, you may notice pinging sounds from the boiler. Adjust the burner if possible to redirect the flame. If this does not work, contact your boiler supplier or Weil-McLain to obtain an optional combustion chamber kit (see page 38 for contents).

5. Adjust flue collar damper (Figure 49) to ensure 0.1" W.C. positive pressure at test opening.
6. Tighten screws to secure in position.
7. Plug test opening with 1/8" plug provided with flue collar/damper assembly.
8. Adjust barometric draft control, when used, to design conditions.
9. Repeat steps 4 through 6. Adjust as required.

Skim steam boilers:

NOTICE Clean all newly installed steam boilers to remove oil. Failure to properly clean can result in violent water level fluctuations, water passing into steam mains, or high maintenance costs on strainers, traps and vents. Skim boiler only. Do not clean old piping or leaks can occur.

WARNING Do not use petroleum-based cleaning or sealing compounds in boiler system. Severe damage to system components can result, causing substantial property damage.

1. Remove 2" plug from skim tapping "A" (see Figure 38, page 27).
2. Provide 2" skim piping from tapping to floor drain.
3. Raise waterline to midpoint of skim piping.
4. Fire burner to maintain temperature below steaming rate during skimming process.
5. Feed in water to maintain water level.
6. Cycle burner ON/OFF as needed to prevent rise in steam pressure.
7. Continue skimming until discharge is clear. This may take several hours.

Figure 49 Flue collar/damper assembly

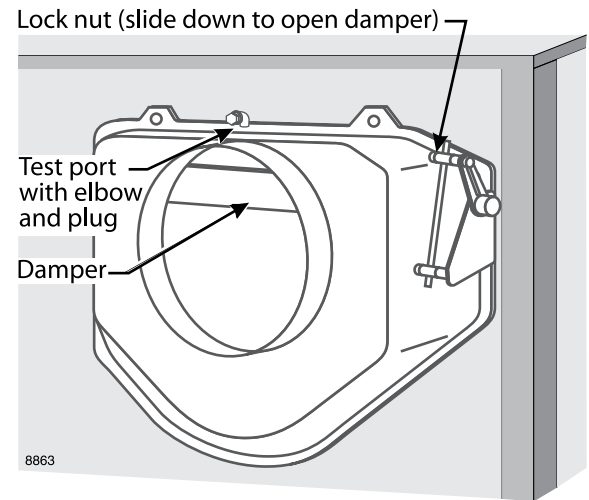

8. Drain boiler.
9. While boiler is warm, **but not hot**, flush all interior surfaces under full pressure until drain water runs clear.
10. Remove skim piping.
11. Re-insert plug at boiler skim tapping.
12. Close drain cock.
13. Fill with fresh water to normal water line.
14. Start burner and steam for 15 minutes to remove dissolved gases.
15. Stop burner.
16. Check traps and air vents for proper operation.

Check boiler for gas-tight seal:

WARNING Boiler must be sealed gas-tight to prevent possible flue gas leakage and carbon monoxide emissions, resulting in severe personal injury or death.

1. Remove boiler jacket side and top panels.

WARNING The boiler contains ceramic fiber and fiberglass materials. Use care when handling these materials per instructions on page 34 of this manual. Failure to comply could result in severe personal injury.

2. Start burner. Observe all sealing points and chalk mark any not gas-tight.
3. To seal all chalk-marked areas:
 - a. Use silicone sealant on section flueways.
 - b. Check gaskets and sealing rope placement.
4. Reinstall all jacket panels.



Handling ceramic fiber and fiberglass materials

REMOVAL OF FRONT PLATE OR CLEANOUT PLATE MATERIALS



The burner front plate and cleanout plate gaskets contain ceramic fiber materials. Ceramic fibers can be converted to cristobalite in very high temperature applications. The International Agency for Research on Cancer (IARC) has concluded, "Crystalline silica inhaled in the form of quartz or cristobalite from occupational sources is carcinogenic to humans (Group 1).":

- Avoid breathing dust and contact with skin and eyes.
 - Use NIOSH certified dust respirator (N95). This type of respirator is based on the OSHA requirements for cristobalite at the time this document was written. Other types of respirators may be needed depending on the job site conditions. Current NIOSH recommendations can be found on the NIOSH web site at <http://www.cdc.gov/niosh/homepage.html>. NIOSH approved respirators, manufacturers, and phone numbers are also listed on this web site.
 - Wear long-sleeved, loose fitting clothing, gloves, and eye protection.
- Apply enough water to the combustion chamber lining or base insulation to prevent airborne dust.
- Remove combustion chamber lining or base insulation from the boiler and place it in a plastic bag for disposal.
- Wash potentially contaminated clothes separately from other clothing. Rinse clothes washer thoroughly.

NIOSH stated First Aid.

- Eye: Irrigate immediately.
- Breathing: Fresh air.

REMOVAL OR INSTALLATION OF FIBERGLASS WOOL:



This product contains fiberglass jacket insulation and ceramic fiber materials in jacket insulation, burner front plate insulation and cleanout plate gaskets. Airborne fibers from these materials have been listed by the State of California as a possible cause of cancer through inhalation.

- Avoid breathing dust and contact with skin and eyes.
 - Use NIOSH certified dust respirator (N95). This type of respirator is based on the OSHA requirements for fiberglass wool at the time this document was written. Other types of respirators may be needed depending on the job site conditions. Current NIOSH recommendations can be found on the NIOSH web site at <http://www.cdc.gov/niosh/homepage.html>. NIOSH approved respirators, manufacturers, and phone numbers are also listed on this web site.
 - Wear long-sleeved, loose fitting clothing, gloves, and eye protection.
- Operations such as sawing, blowing, tear out, and spraying may generate airborne fiber concentration requiring additional protection.
- Wash potentially contaminated clothes separately from other clothing. Rinse clothes washer thoroughly.

NIOSH stated First Aid.

- Eye: Irrigate immediately.
- Breathing: Fresh air.



Ratings

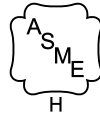

AHRI Certified Ratings

Boiler model number	AHRI burner capacity		Gross AHRI output		Net AHRI ratings			Combustion efficiency		Thermal efficiency		Boiler H.P.	Net firebox volume	Flue gas volume	Flue outlet dia.	Boiler water content	Packaged boiler weight
	Light oil	Gas	Steam	Water	Steam	Steam	Water	Oil	Gas	Oil	Gas		Cubic feet	CFM	Inches	Gallons	Pounds
	GPH	MBH	MBH	MBH	Sq. Ft	MBH	MBH	%	%	%	%						
Notes: 1, 10	2, 3	2, 4	5, 6	5, 6	8	8	8	%	%	%	%	—	—	7	—	—	—
488R	6.9	996	827	833	2,583	620	719	87.5	84.8	85.6	83.1	24.7	11.02	376	10	109	2,860
488	7.0	1,010	839	844	2,621	629	730	87.5	84.8	85.6	83.1	25.1	11.02	370	10	109	2,860
588	9.4	1,356	1,126	1,135	3,521	845	979	87.0	84.4	85.6	83.1	33.6	14.45	507	10	132	3,340
688	11.8	1,701	1,413	1,424	4,469	1,072	1,229	86.7	84.1	85.6	83.1	42.2	18.08	639	10	155	3,820
788	14.2	2,046	1,700	1,713	5,463	1,311	1,478	86.5	83.9	85.6	83.1	50.8	21.61	772	12	178	4,345
788R	--	1999	1661	1673	5,463	1279	1,444	--	84.0	--	83.1	50.8	21.61	772	12	178	4,345
888	16.6	2,382	1,987	1,994	6,427	1,543	1,728	86.3	83.7	85.6	83.1	59.4	25.14	906	12	201	4,925
988R	17.2	2,482	2,062	2,080	6,671	1,601	1,793	86.2	83.7	85.6	83.1	61.6	28.67	1,031	14	224	5,600
988	18.8	2,737	2,274	2,294	7,358	1,766	1,977	86.2	83.7	85.6	83.1	67.9	28.67	954	14	224	5,600
1088R	20.0	2,887	2,399	2,419	7,763	1,863	2,086	86.2	83.6	85.6	83.1	71.7	32.20	1,184	14	247	6,130
1088	21.5	3,082	2,561	2,583	8,283	1,988	2,227	86.2	83.6	85.6	83.1	76.5	32.20	1,101	14	247	6,130
1188	23.5	3,428	2,848	2,873	9,213	2,211	2,477	86.1	83.5	85.7	83.1	85.1	35.76	1,299	14	270	6,695
1288	26.0	3,773	3,135	3,162	10,147	2,434	2,726	86.0	83.5	85.7	83.1	93.7	39.26	1,443	14	293	7,260
1388	28.5	4,119	3,422	3,456	11,071	2,657	2,976	86.0	84.4	85.7	83.1	102.2	42.79	1,588	14	316	7,890
1488	31.0	4,464	3,709	3,745	12,000	2,880	3,225	86.0	83.4	85.7	83.1	110.8	46.32	1,735	16	339	8,410
1588	33.0	4,809	3,996	4,035	12,925	3,102	3,475	85.9	83.3	85.7	83.1	119.4	49.85	1,854	16	362	9,005
1688R	34.5	4,979	4,137	4,182	13,383	3,212	3,597	85.9	83.3	85.7	83.1	123.6	53.38	2,003	16	385	9,525
1688	35.5	5,155	4,283	4,330	13,854	3,325	3,724	85.9	83.3	85.7	83.1	127.9	53.38	1,945	16	385	9,525
1788	38.0	5,494	4,570	4,615	14,783	3,548	3,974	85.9	83.3	85.7	83.1	136.5	56.91	2,152	18 *	408	9,780
1888	40.5	5,845	4,857	4,910	15,713	3,771	4,223	85.9	83.3	85.7	83.1	145.1	60.44	2,303	18 *	431	10,775

1. See below to specify complete model number.

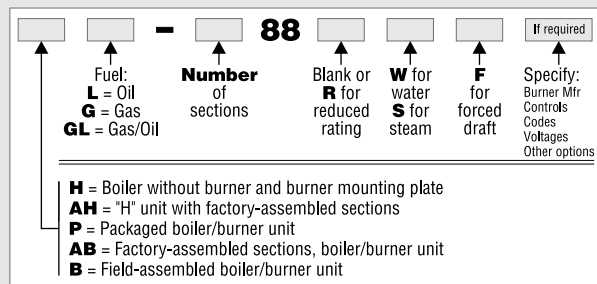

2. Burner input based on maximum of 2,000 feet altitude. For other altitudes, consult Weil-McLain distributor/agent or sales office.
3. No. 2 fuel oil — Commercial Standard Spec CS75-56. Heating value of oil = 140,000 Btu per gallon.
4. Gas pressure required at burner gas train inlet for rated burner input; based on 1,000 Btu per cubic foot natural gas, specific gravity of 0.60. Refer to burner manual for required pressure.

5. Gross AHRI ratings have been determined under the AHRI provision governing forced draft boiler-burner units.
 6. Flue gas volume at outlet temperature.
 7. Net AHRI ratings are based on net installed radiation of sufficient quantity for the requirements of the building. Nothing need be added for normal piping and pick-up. Water ratings are based on a piping and pick-up allowance of 1.15. Steam ratings are based on the following allowances: 488 – 588 = 1.333; 688 = 1.323; 788 = 1.301; 888 = 1.289; 988 – 1888 = 1.288. An additional allowance should be made for gravity hot water systems or for unusual piping and pick-up loads. Consult local Weil-McLain distributor/agent or sales office.
 8. With 0.10" W.C. positive pressure at flue collar.
 9. Water boilers tested for 80 PSIG, ASME water working pressure. Steam boilers tested for 15 PSIG, ASME steam working pressure.
- * Flue collar connection is oval, 16 1/8" x 19 7/8"



Dimensions

Dimensions (inches)								
Model	A	B	C	D	E	L	W	H
488	23	—	—	10	54 ³ / ₄	34 ³ / ₄	30	23 ³ / ₈
588	31	—	—	10	54 ³ / ₄	42 ³ / ₄	38	31 ³ / ₈
688	39	—	—	10	54 ³ / ₄	50 ³ / ₄	46	39 ³ / ₈
788	47	—	—	12	53 ³ / ₄	58 ³ / ₄	54	47 ³ / ₈
888	55	—	—	12	53 ³ / ₄	66 ³ / ₄	62	55 ³ / ₈
988	63	—	—	14	52 ³ / ₄	74 ³ / ₄	70	63 ³ / ₈
1088	71	—	—	14	52 ³ / ₄	82 ³ / ₄	78	71 ³ / ₈
1188	79	—	—	14	52 ³ / ₄	90 ³ / ₄	86	79 ³ / ₈
1288	87	39 ¹ / ₂	—	14	52 ³ / ₄	98 ³ / ₄	94	87 ³ / ₈
1388	95	47 ¹ / ₂	—	14	52 ³ / ₄	106 ³ / ₄	102	95 ³ / ₈
1488	103	55 ¹ / ₂	—	16	51 ³ / ₄	114 ³ / ₄	110	103 ³ / ₈
1588	111	63 ¹ / ₂	—	16	51 ³ / ₄	122 ³ / ₄	118	111 ³ / ₈
1688	119	47 ¹ / ₂	—	16	51 ³ / ₄	130 ³ / ₄	126	119 ³ / ₈
1788	127	31 ¹ / ₂	79 ¹ / ₂	16 ¹ / ₈ " x 19 ⁷ / ₈ " oval	51 ³ / ₄	138 ³ / ₄	134	127 ³ / ₈
1888	135	39 ¹ / ₂	87 ¹ / ₂		51 ³ / ₄	146 ³ / ₄	142	135 ³ / ₈

Model	Supply & return tapplings				Burner lengths (Dimension F)				
	Supply tapplings (No. & size)		Return tapplings (No. & size)		Carlin	Riello	Power-Flame	Beckett Oil	Beckett Gas
	Steam	Water	Steam	Water					
488R	2 – 5"	2 – 5"	1 – 6"	1 – 6"	21	33	31	21	29
488	2 – 5"	2 – 5"	1 – 6"	1 – 6"	21	33	31	21	30
588	2 – 5"	2 – 5"	1 – 6"	1 – 6"	21	33	31	21	30
688	2 – 5"	2 – 5"	1 – 6"	1 – 6"	21	33	34	22	30
788	2 – 5"	2 – 5"	1 – 6"	1 – 6"	21	33	34	22	30
888	2 – 5"	2 – 5"	1 – 6"	1 – 6"	21	49	34	22	30
988R	2 – 5"	2 – 5"	1 – 6"	1 – 6"	21	49	34	22	30
988	2 – 5"	2 – 5"	1 – 6"	1 – 6"	26	49	34	22	30
1088R	2 – 5"	2 – 5"	1 – 6"	1 – 6"	26	49	34	22	30
1088	2 – 5"	2 – 5"	1 – 6"	1 – 6"	26	49	34	22	30
1188	2 – 5"	2 – 5"	1 – 6"	1 – 6"	26	49	39	23	30
1288	3 – 5"	2 – 5"	1 – 6"	1 – 6"	26	49	39	23	30
1388	3 – 5"	2 – 5"	1 – 6"	1 – 6"	26	49	39	23	30
1488	3 – 5"	2 – 5"	1 – 6"	1 – 6"	26	49	39	—	30
1588	3 – 5"	2 – 5"	1 – 6"	1 – 6"	—	49	39	—	—
1688R	3 – 5"	2 – 5"	1 – 6"	1 – 6"	—	49	39	—	—
1688	3 – 5"	2 – 5"	1 – 6"	1 – 6"	—	49	39	—	—
1788	4 – 5"	2 – 5"	1 – 6"	1 – 6"	—	49	44	—	—
1888	4 – 5"	2 – 5"	1 – 6"	1 – 6"	—	56	44	—	—



Dimensions *(continued)*

Figure 50 Dimensions (see lettered dimensions on opposite page)

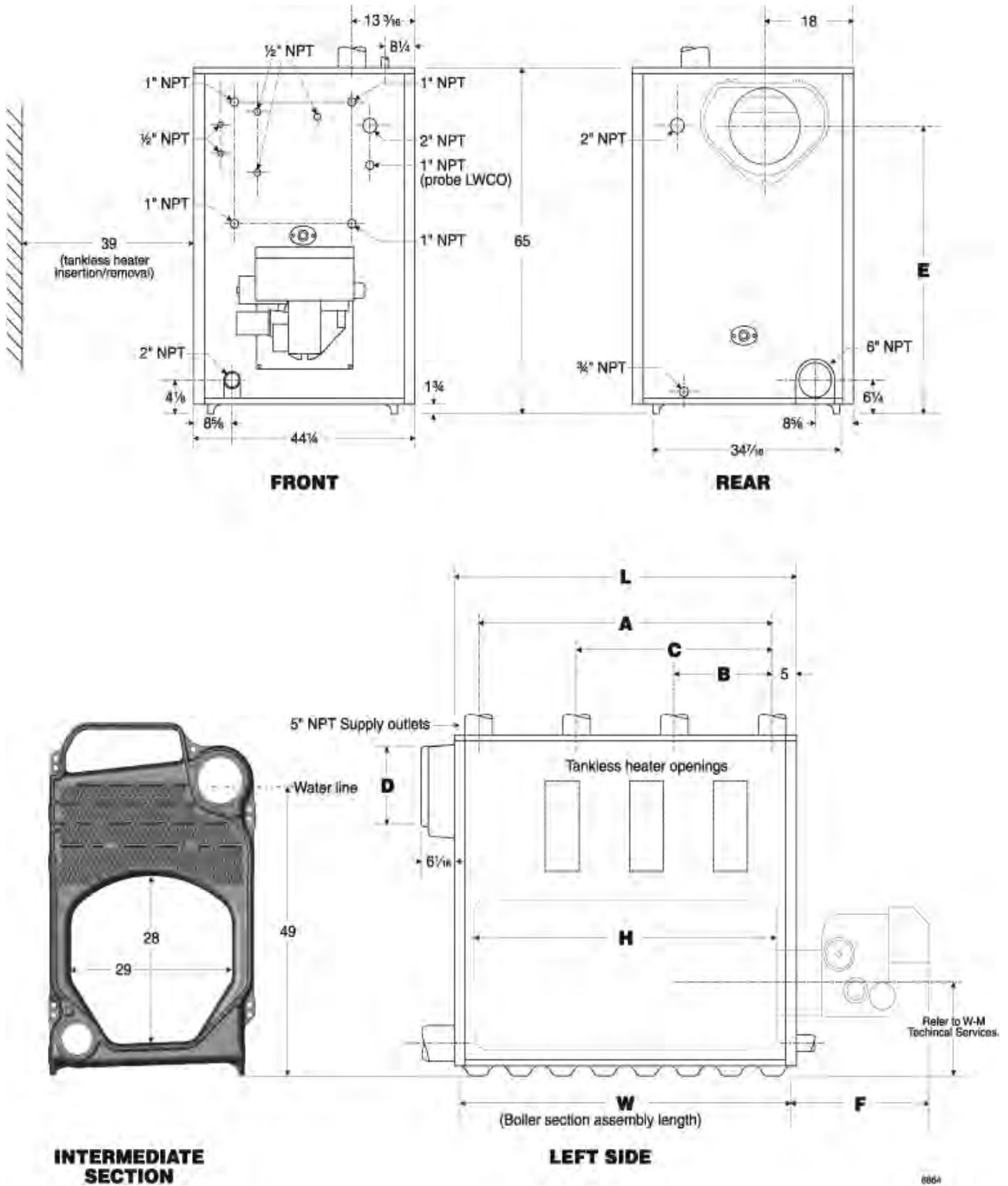



Parts

Item	Description	Part number
1	Front sections (8823)	316-301-210
2	Regular intermediate section (8825)	316-301-212
3	Tankless intermediate section (8826)	316-301-214
4	Back section (8828)	316-301-211
—	Supply intermediate section (8824) (not shown)	316-301-213
—	Section replacement kit (includes rope seals, rope adhesive and sealant for one joint)	386-300-213
5	Burner mounting plate	Order for specific burner
6	Sealing rope — ½" (7 feet per burner plate)	590-735-140
7	Tankless heater, when used, number 820	590-291-909
8	Heater gasket	590-317-579
9	Heater cover plate	450-030-934
10	Draw rod 5/8"-11UNC-2A x 13" (apply to front and rear sections)	560-134-505
11	Draft hood collar assembly (includes damper collar, damper, damper quadrant, locking plate, swivel, brackets and rope) a. 10-inch — 488 through 688 b. 12-inch — 788 and 888 c. 14-inch — 988 through 1388 d. 16-inch — 1488 through 1688 e. 18-inch — 1788 and 1888 f. Quadrant for flue collar g. Damper blade h. Damper locking plate	340-004-606 340-004-607 340-004-608 340-004-609 340-004-612 330-056-634 460-003-646 563-530-784
12	Sealing rope ½" (6 feet for flue collar)	590-735-140
13	Cleanout plate	450-030-965
14	Woven fiberglass gasket for cleanout plate	590-317-305
15	Observation port assembly (includes frame, rope, gasket, plugs and sight glass) (2 per boiler) a. Assembly b. Sight glass only c. Washer gasket for sight glass (2½ x 1¼ x ⅞ inches)	383-600-099 591-419-199 590-317-580
16	Sealing rope, ⅜" (1 foot per observation port)	590-317-150
17	Burner mounting plate studs (½ x 3½ inches)	Obtain locally
18	Cleanout plate nut, ¼"	Obtain locally
19	Cap screw, ½-13 x ¾"	Obtain locally
20	Observation port screw, 10-32 x 1½"	Obtain locally
21	Flue collar cap screw, ½" x 1½"	Obtain locally
22	Flue collar washer, 1¼"	Obtain locally
23	Burner mounting plate washer, ½"	Obtain locally
24	Burner mounting plate nut, ½"	Obtain locally
25	Draw rod nut, ⅝"	Obtain locally
26	Cleanout plate washer, ¼"	Obtain locally
27	Cleanout plate carriage bolt, ¼" x 1¾"	Obtain locally
28	HXT-bars (see Figure 12, page 12, for installation and placement details for HXT-bars) d. 3-flueway kit (includes 3 sets of bars) e. 2-flueway kit (includes 2 sets of bars)	416-400-130 416-400-131
Not shown	Combustion chamber liner kit (optional) — includes ceramic fiber blanket for left side wall plus water glass adhesive — see page 33. Consult your local Weil-McLain sales office for details.	Contact local Weil-McLain sales office

Parts *(continued)*

Figure 51 Parts

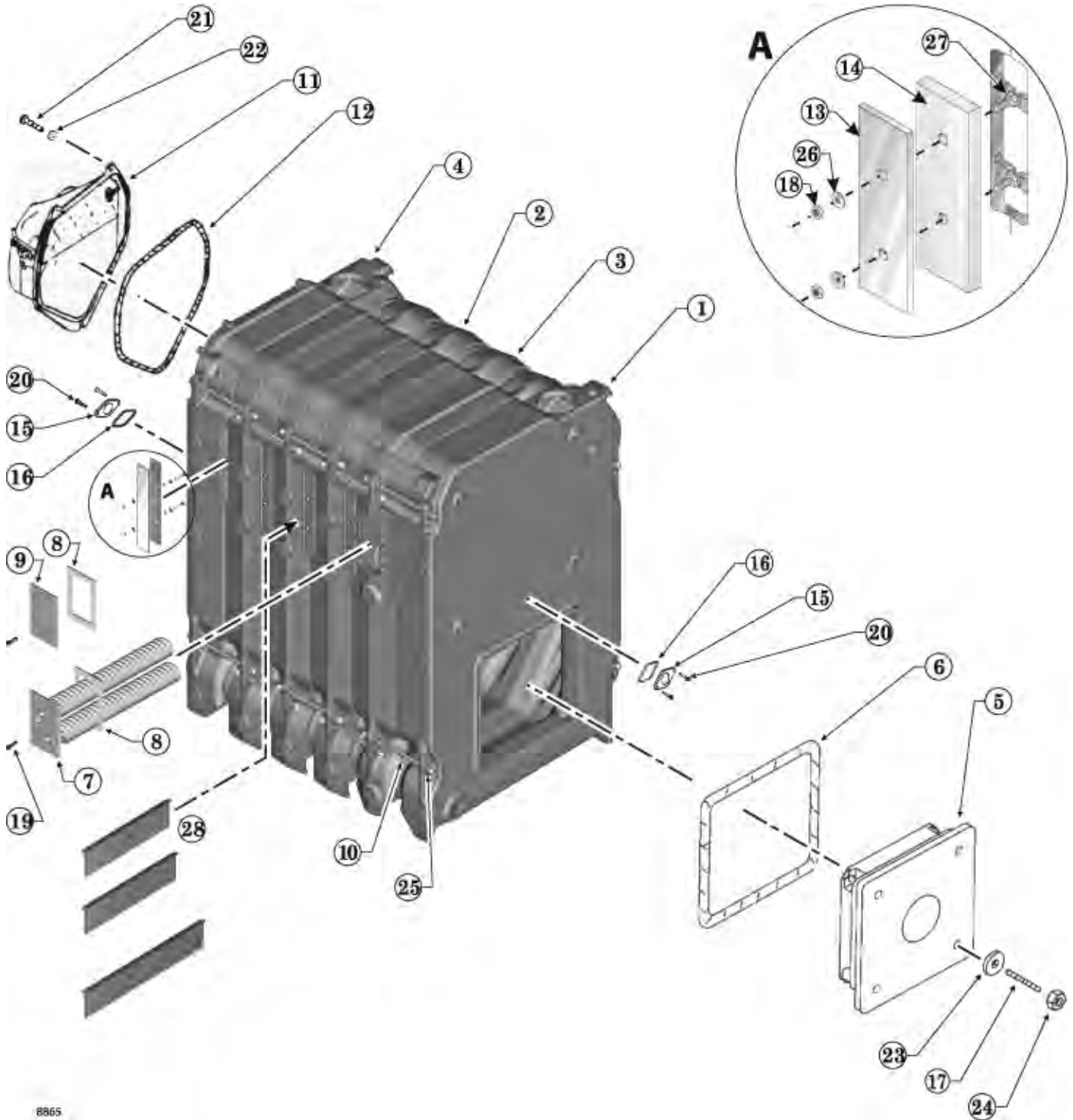



Weil-McLain
500 Blaine Street
Michigan City, IN 46360-2388
<http://www.weil-mclain.com>