



EG·PEG·EGH

Gas-Fired Boilers – Series 4



CLICK ANYWHERE on THIS PAGE to RETURN to
Weil-McLain BOILERS, GAS BURNERS & GAS VALVES
CONTROLS at InspectApeia.com

Boiler Manual

- Installation
- Maintenance
- Startup
- Parts

EG
PEG



For additional information, refer to . . .

**Control Supplement and Gas
Control Parts**

*for Natural or Propane gas
(tankless heater application optional)*

EGH



Mobile Product
Library



This manual must only be used by a qualified heating installer/service technician. **Before installing**, read all instructions, including this manual, the burner manual and any related supplements. Perform steps in the order given. Failure to comply could result in severe personal injury, death or substantial property damage.

Part No. 550-110-639/0512

Read this page first

Hazard definitions

The following defined terms are used throughout this manual to bring attention to the presence of hazards of various risk levels, or to important information concerning the life of the product.

▲ DANGER Indicates presence of hazards that will cause severe personal injury, death or substantial property damage.

▲ WARNING Indicates presence of hazards that can cause severe personal injury, death or substantial property damage.

▲ CAUTION Indicates presence of hazards that will or can cause minor personal injury or property damage.

NOTICE Indicates special instructions on installation, operation or maintenance that are important but not related to personal injury or property damage.

▲ WARNING Read all instructions before installing. Failure to follow all instructions in proper order can cause severe personal injury, death or substantial property damage.

Improper installation, adjustment, alteration, service or maintenance can cause property damage, personal injury, exposure to hazardous materials, or loss of life. Refer to the User's Information Manual provided with this boiler. Installation and service must be performed by a qualified installer, service agency or the gas supplier who must read and follow the supplied instructions before installing, servicing or removing this boiler. This boiler contains possibly carcinogenic, to humans.

NOTICE When calling or writing about the boiler: Please have the boiler model number from the boiler rating label and the CP number from the boiler jacket. You may list the CP number in the space provided on the **Installation and Service Certificate** found on page 27.

NOTICE EG and EGH boilers for tankless or storage heater application are available only on special order as factory-installed optional equipment. Tankless heater cannot be added to standard block assembly. Block assembly must be ordered with heater openings. Standard boilers cannot be adapted for heater use.

▲ WARNING Failure to adhere to the guidelines below can result in severe personal injury, death or substantial property damage.

When servicing boiler —

1. The boiler contains ceramic fiber and fiberglass materials. Use care when handling these materials per instructions on page 28 of this manual. Failure to comply could result in severe personal injury.
2. To avoid electric shock, disconnect electrical supply before performing maintenance.
3. To avoid severe burns, allow boiler to cool before performing maintenance.

Boiler operation —

4. Do not block flow of combustion or ventilation air to boiler.
5. Should overheating occur, turn off or disconnect electrical supply to boiler and shut off the gas supply at a location external to the appliance, if possible.
6. Do not use this boiler if any part has been under water. Immediately call a qualified service technician to inspect the boiler and to replace any part of the control system and any gas control that has been under water.

Boiler water —

7. DO NOT use petroleum-based cleaning or sealing compounds in boiler system. Water seal deterioration will occur, causing leakage between boiler sections, circulator flanges, diaphragm tanks or other system components. This can result in substantial property damage.
8. DO NOT use “homemade cures” or “boiler patent medicines”. Serious damage to boiler, personnel and/or property may result.
9. Continual fresh makeup water will reduce boiler life. Mineral buildup in sections reduces heat transfer, overheats cast iron, and causes section failure. Addition of oxygen and other gases can cause internal corrosion. Leaks in boiler or piping must be repaired at once to prevent makeup water.
10. Do not add cold water to hot boiler. Thermal shock can cause sections to crack.

Glycol — potential fire hazard —

All glycol is flammable when exposed to high temperatures. If glycol is allowed to accumulate in or around the boiler or any other potential ignition source, a fire can develop. In order to prevent potential severe personal injury, death or substantial property damage from fire and/or structural damage:

- Never store glycol of any kind near the boiler or any potential ignition source.
- Monitor and inspect the system and boiler regularly for leakage. Repair any leaks immediately to prevent possible accumulation of glycol.
- Never use automotive antifreeze or ethylene glycol in the system. Using these glycols can lead to hazardous leakage of glycol in the boiler system.

Contents

Codes and Checklist 4

Prepare boiler location 5

Prepare the boiler 9

Connect piping — water boilers 14

Connect piping — steam boilers 17

Install boiler controls 20

Connect piping — tankless heater 21

Connect gas supply piping 22

Connect field wiring to boiler. . 23

Start-up 24

**Handling fiberglass and ceramic fiber
materials 28**

Service and maintenance 29

Replacement parts — EG/PEG. . 33

Replacement parts — EGH 35

Dimensional data 37

Ratings 38

Standard and optional equipment 39

Codes & Checklist

Installation must follow these codes:

- Local codes, laws, provincial and national codes, laws, regulations and ordinances
- National Fuel Gas Code ANSI Z223.1- latest edition
- Standard for Controls and Safety Devices for Automatically Fired Boilers, ANSI/ASME CSD-1, when required
- National Electric Code

The equipment shall be installed in accordance with those installation regulations in force in the local area where the installation is to be made. These shall be carefully followed in all cases. Authorities having jurisdiction shall be consulted before installations are made.

Canadian installations must comply with CAN/CSA B149.1 or B149.2 Installation Codes.

Commonwealth of Massachusetts

When the boiler is installed within the Commonwealth of Massachusetts:

- This product must be installed by a licensed plumber.
- If antifreeze is used, a reduced pressure back-flow preventer device shall be used.

Certification

NOTICE Safe lighting and other performance criteria were met with the gas manifold and control assembly provided on boiler when boiler underwent tests specified in ANSI Z21.13-latest edition.

Before locating the boiler:

- Check for nearby connection to:
 - Venting connections
 - Gas supply piping
 - Electrical power
 - Check area around boiler. Remove any combustible materials, gasoline and other flammable liquids.
- WARNING** Failure to keep boiler area clear and free of combustible materials, gasoline and other flammable liquids and vapors can result in severe personal injury, death or substantial property damage.
- Boiler must be installed so that gas control system components are protected from dripping or spraying water or rain during operation or service.
 - If new boiler will replace existing boiler, check for and correct system problems, such as:
 - System leaks causing oxygen corrosion or section cracks from hard water deposits.

Prepare boiler location

Recommended Service clearances

1. Provide minimum clearances for cleaning and servicing the boiler and for access to controls and components as listed in the table at right.
2. Provide at least screwdriver clearance to jacket front panel screws for removal of front panel for inspection and minor service. If unable to provide at least screwdriver clearance, install unions and shutoff valves in system so boiler can be moved for servicing.

Combustible material clearances

General

1. See Table 1 for clearances to boiler and system components.
2. Clearances to Type B vent materials are as specified by the vent manufacturer.

Alcove (not closet) installations only

⚠ WARNING EG and PEG boilers are not approved for closet installation.

EG and PEG boilers are approved for **alcove** installation, with minimum clearances to combustible surfaces as shown in Table 1. See Figure 1. The front side must be completely open — that is, a three-walled room.

EGH boilers are not approved for alcove or closet installation.

Table 1 EG, PEG & EGH -Service and combustible materials clearances

EG, PEG & EGH - Clearance for service	Minimum
Clearance to boiler jacket	
Top (for cleaning flueways)	46"
Front (for access to controls and components)	18"
Back	6"
Left side (for cleaning and servicing)	24"
Right side	6"

Clearance to combustible materials	Minimum EG & PEG	Minimum EGH
Clearance to boiler jacket		
Top	46"	24"
Front (provides means of access)	3"	18"
Back	6"	24"
Left side (provides means of access)	4"	24"
Right side	4"	24"
Clearance to piping and vent components		
Water and steam pipes	1/2"	1/2"
Vent pipe (other than Type B vent)	6"	6"
Type B vent piping	Per B vent manufacturer	Per B vent manufacturer
Vent damper	6"	6"

Figure 1 Alcove installation (EG & PEG only)

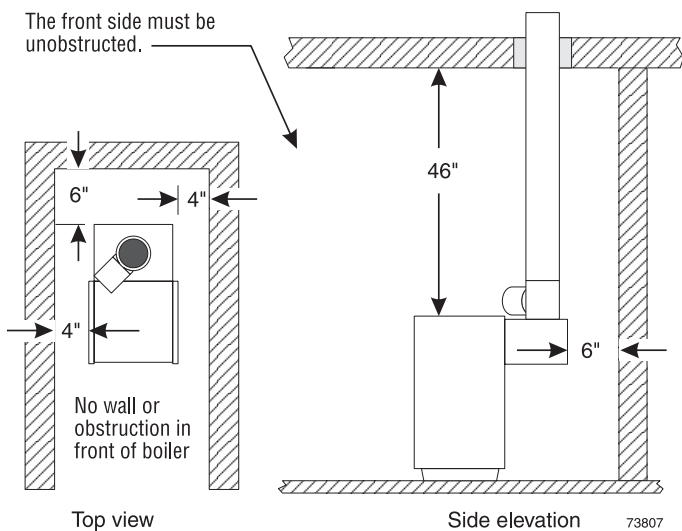

1. For EGH boilers, See Table 1 for clearances to boiler and system components.

EGH installations

1. Provide the clearances for service listed on this page.
2. Install in a space that is large in comparison to the size of the boiler (see National Fuel Gas Code for details).

Residential garage installations

Take the following special precautions when installing the boiler in a residential garage. If the boiler is located in a residential garage, per ANSI Z223.1:

- Mount the boiler a minimum of 18 inches above the floor of the garage to assure the burner and ignition devices will be no less than 18 inches above the floor.
- Locate or protect the boiler so it cannot be damaged by a moving vehicle.

1 Prepare boiler location *(continued)*

Flooring and foundation

WARNING Do not install boiler on combustible flooring or carpeting even if a concrete or aerated foundation is used. Fire can result, causing severe personal injury, death or substantial property damage.

1. See Figure 2. A level concrete or solid brick pad is required if:
 - a) There is a possibility of the floor becoming flooded.
 - b) Non-level conditions exist.
2. An aerated boiler foundation is recommended if any of the following conditions exist:
 - a) Electrical wiring or telephone cables buried in the concrete floor of the boiler room.
 - b) Concrete floor is “green.”
 - c) There is a history of the floor becoming flooded.
 - d) Water is channeled under the concrete.

Figure 2 Boiler foundation

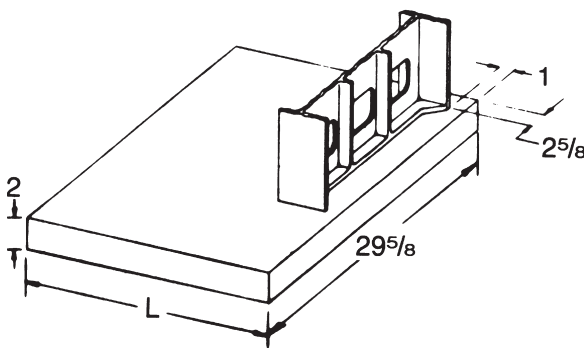

Table 2 Minimum foundation size

Boiler Foundation Size - Inches			
Boiler No.	“L”	Boiler No.	“L”
EG 30-35	19	EGH 85	40 1/4
EG 40-45	23 1/4	EGH 95	44 1/2
EG 50-55	27 1/2	EGH 105	48 3/4
EG 65	31 3/4	EGH 115	53
EG 75	36	EG 125	57 1/4

Vent System

WARNING Failure to follow all instructions can result in flue gas spillage and carbon monoxide emissions, causing severe personal injury or death.

DANGER Inspect existing chimney before installing boiler. Failure to clean or replace perforated pipe or tile lining will cause severe personal injury or death.

DANGER Do not alter boiler draft diverter or place any obstruction or non-certified vent damper in breeching or vent system. CSA certification will become void. Flue gas spillage and carbon monoxide emissions will occur causing severe personal injury or death.

NOTICE The following requirements apply when you remove an existing boiler from a vent system shared with other appliances. If the new boiler will not use the common vent, you must test (as described below) each remaining appliance — operating by itself — to verify that the vent system operates adequately.

When removing boiler from existing common vent system:

At the time of removal of an existing boiler, the following steps shall be followed with each appliance remaining connected to the common venting system placed in operation, while the other appliances remaining connected to the common venting system are not in operation.

- a. Seal any unused openings in the common venting system.
- b. Visually inspect the venting system for proper size and horizontal pitch and determine there is no blockage or restriction, leakage, corrosion or other deficiencies which could cause an unsafe condition.
- c. Test vent system — Insofar as is practical, close all building doors and windows and all doors between the space in which the appliances remaining connected to the common venting system are located and other spaces of the building. Turn on clothes dryers and any appliance not connected to the common venting system. Turn on any exhaust fans, such as range hoods and bathroom exhausts, so they will operate at maximum speed. Do not operate a summer exhaust fan. Close fireplace dampers.
- d. Place in operation the appliance being inspected. Follow the lighting instructions. Adjust thermostat so appliance will operate continuously.
- e. Test for spillage at draft diverter relief opening after 5 minutes of main burner operation. Use the flame of a match or candle.
- f. After it has been determined that each appliance remaining connected to the common venting system properly vents when tested as outlined above, return doors, windows, exhaust fans, fireplace dampers, and any other gas-burning appliance to their previous conditions of use.

Any improper operation of the common venting system should be corrected so the installation conforms with the National Fuel Gas Code, ANSI Z223.1/NFPA 54 and/or CAN/CGA B149 or B149.2, Installation Codes. When resizing any portion of the common venting system, the common venting system should be resized to approach the minimum size as determined using the appropriate tables in the National Fuel Gas Code, ANSI Z223.1/NFPA 54 and/or CAN/CGA B149 or B149.2, Installation Codes.

Prepare boiler location

Vent System *(continued)*

Chimney or vent requirements

- Venting must be installed according to the National Fuel Gas Code, ANSI Z223.1—latest edition and applicable building codes. Canadian installations must comply with B149.1 or B149.2 Installation Codes.
- See “Ratings” on page 38 for minimum chimney or vent sizes. Chimney or vent termination:
 - A chimney, or any vent other than a Type B vent with listed vent cap, must extend at least 3 feet above the highest point where it passes through a roof of a building, and at least 2 feet higher than any portion of a building within a horizontal distance of 10 feet.
 - Type B vents with listed caps may terminate as in Figure 3 if no closer than 8 feet from a vertical wall or similar obstruction.
 - Otherwise, Type B vents must terminate at least 2 feet above the roof penetration and at least 2 feet higher than any portion of a building within 10 feet.
- A lined chimney is preferred and must be used when required by local, state, provincial and national codes, laws, regulations and ordinances. Vitreous tile linings with joints that prevent retention of moisture and linings made of noncorrosive materials are best. Advice for flue connections and chimney linings can be obtained from local gas utility. Type B double-wall metal vent pipe or single-wall vent pipe may be used as a liner.
- Cold masonry chimneys, also known as outside chimneys, typically have one or more walls exposed to outside air. When any atmospheric gas-fired boiler with automatic vent damper is vented through this type of chimney, the potential exists for condensation to occur. Condensation can damage a masonry chimney. The following are recommended to prevent possible damage.
 - Line chimney with corrosion-resistant metal liner such as AL29-4C® single-wall stainless steel or B-vent. Size liner per National Fuel Gas Code ANSI Z223.1—latest edition.
 - Provide drain trap to remove any condensate.
- Where two or more gas appliances vent into a common chimney or vent, equivalent area should be at least equal to area of vent outlet on largest appliance plus 50 percent of vent outlet area of additional appliances.

Air contamination

- Please review the following information on potential combustion air contamination problems.
- See Table 3 for products and areas which may cause contaminated combustion air.

⚠ WARNING To prevent potential of severe personal injury or death, check for products or areas listed below before installing boiler. If any of these contaminants are found:

- Remove contaminants permanently.
— OR —
- Isolate boiler and provide outside combustion air. See national, provincial or local codes for further information.

Table 3 Contaminants to avoid

Products to avoid
Spray cans containing chloro/fluorocarbons
Permanent wave solutions
Chlorinated waxes/cleaners
Chlorine-based swimming pool chemicals
Calcium chloride used for thawing
Sodium chloride used for water softening
Refrigerant leaks
Paint or varnish removers
Hydrochloric acid/muriatic acid
Cements and glues
Antistatic fabric softeners used in clothes dryers
Chlorine-type bleaches, detergents, and cleaning solvents found in household laundry rooms
Adhesives used to fasten building products and other similar products
Areas likely to have contaminants
Dry cleaning/laundry areas and establishments
Swimming pools
Metal fabrication plants
Beauty shops
Refrigeration repair shops
Photo processing plants
Auto body shops
Plastic manufacturing plants
Furniture refinishing areas and establishments
New building construction
Remodeling areas
Garages with workshops

Figure 3 Terminations with Type B vent fitted with listed cap, provided vent is at least 8 feet from any vertical wall or similar obstruction

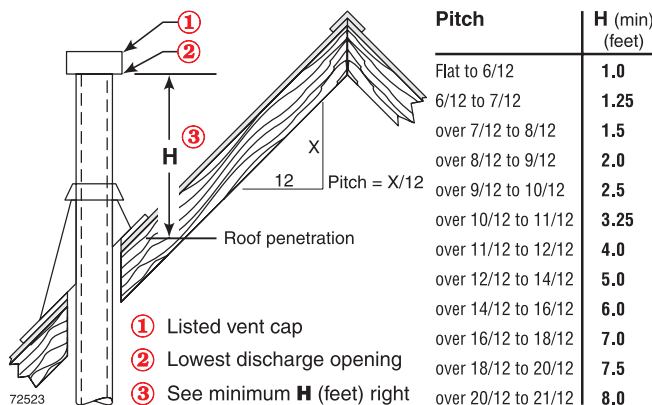

Prepare the location

Air openings

WARNING Provide adequate combustion and ventilation air to assure proper combustion and reduce the risk of severe personal injury, death or substantial property damage caused by flue gas spillage and carbon monoxide emissions.

Combustion air and ventilation openings must comply with the National Fuel Gas Code, ANSI Z223.1 – latest edition, or applicable local building codes. Canadian installations must comply with B149.1 or B149.2 Installation Codes.

Air opening sizes in the following are given in free area (after correction for louver obstruction).

Option 1 – Provide (2) openings:

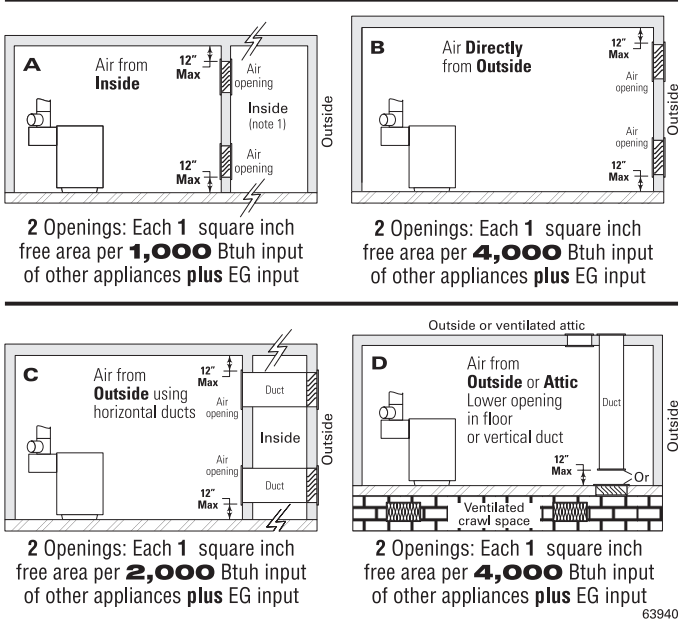

Option 2 – Provide (1) opening:

A single combustion air opening can be used, provided:

- The opening must commence within 12 inches of the ceiling.
- The boiler must have clearances of at least 1 inch from both sides and back, and 6 inches from the front.
- The opening must connect directly to the outdoors or to a space that communicates directly to the outdoors.
- The air can be provided through a direct opening or through a horizontal or vertical duct.
- The free area of the opening must be at least equal to the sum of all vent connectors in the space.
- The free area of the opening must be at least 1 square inch per 3000 Btu/hr input rating of all equipment located in the space.

Tight construction — Definition:

Tight construction means (per ANSI Z223.1):

- Walls and ceilings exposed to the outside atmosphere have a continuous water vapor retarder with a rating of 1 perm or less with openings gasketed. AND
- Weather-stripping has been added on openable windows and doors. AND
- Caulking or sealants are applied to areas such as joints around windows and door frames, between sole plates and floors, between wall-ceiling joints, between wall panels, at penetrations for plumbing, electrical, and gas lines, and in other openings.

Tight construction requirements

If building is of tight construction and air is taken from inside the building, provide two openings in building outside wall, one within 12 inches of ceiling, the other within 12 inches of the floor. Each opening must have a minimum free area of 1 square inch per 1,000 Btuh of all appliances in the building.

Exception

NO combustion air openings are needed when the boiler (and other appliances) are installed in a space with a volume NO LESS than 50 cubic feet per 1,000 Btuh of all installed appliances. Sum the total input of all appliances in MBH (1,000's of Btuh) and multiply this number times 50. Building must not be of Tight construction (see above).

Example: For total input of 100 MBH (100,000 Btuh), minimum volume is $50 \times 100 = 5,000$ cubic feet. At a ceiling height of 8 feet, space must have at least $5,000 \div 8 = 625$ square feet (25 feet x 25 feet, for instance).

Exhaust fans and air movers

The appliance space must never be under a negative pressure. Always provide air openings sized not only to the dimensions required for the firing rate of all appliances, but also to handle the air movement rate of the exhaust fans or air movers using air from the building or space.

Motorized air dampers

If the air openings are fitted with motorized dampers, electrically interlock the damper to:

- Prevent the boiler from firing if the damper is not fully open.
- Shut the boiler down should the damper close during boiler operation.

To accomplish this interlock, wire an isolated contact (proving the damper open) in series with the thermostat input to the boiler. The boiler will not start if this damper is closed, and will shut down should damper close during operation.

Placement and setup

Place boiler/crate near position

1. Leave boiler in crate and on pallet until installation site is ready.
2. Move entire crate and pallet next to selected location.
3. Remove crate. **Leave boiler on pallet.**
4. Unbolt boiler from pallet.
5. Remove boiler from pallet.

Prepare the boiler

Placing the boiler

⚠WARNING Block assembly is extremely heavy. Handle with caution to avoid personal injury.

EGH boilers only —

When an EGH block assembly is taken apart for handling:

1. Put a support under center of block. Support must be within ½ inch of block bottom.
2. Detach seal replacement kit from the draw rod. Remove short center draw rods.
3. Tip half blocks on end as shown in Figure 4. Save elastomer sealing ring between sections.
4. Remove the exposed silicone from the socket areas located in the bottom-front and top-rear corners of the casting. See Figure 4a. Do not remove the rope seal.
5. After moving half-blocks into desired location, clean port surfaces with clean, dry rag. Do not use petroleum-based solvents. Place sealing rings in recessed ports. Place new silicone in the socket area as seen in Figure 4b. It is critical to place enough silicone in this area to reseal the castings.

⚠WARNING Do not use petroleum-based cleaning or sealing compounds in boiler system. Severe damage to system components can result, causing substantial property damage.

6. Re-assemble block in reverse order. When drawing sections together, use 45 (± 5) ft-lbs torque.

Figure 4 Handling split blocks

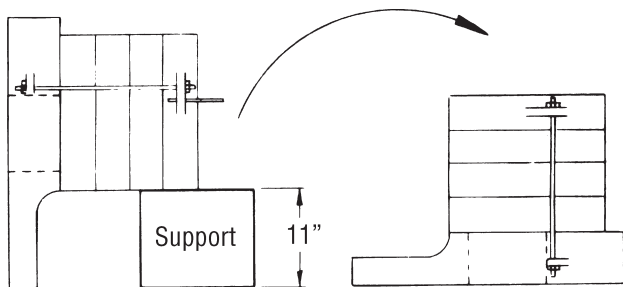

Figure 4a Corner after exposed silicone has been removed.

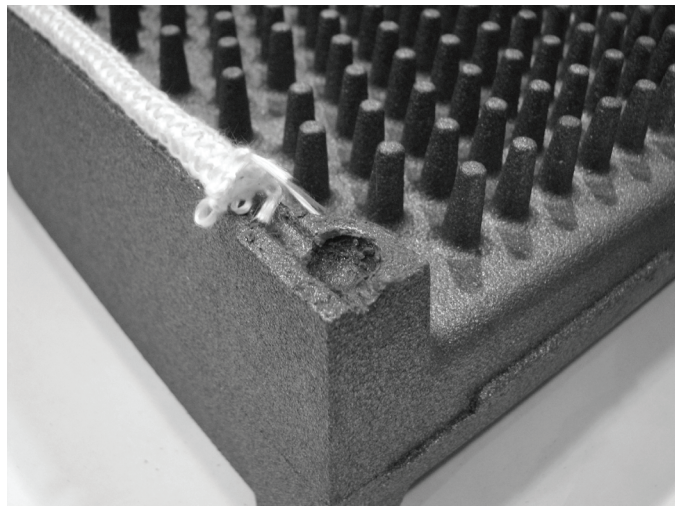
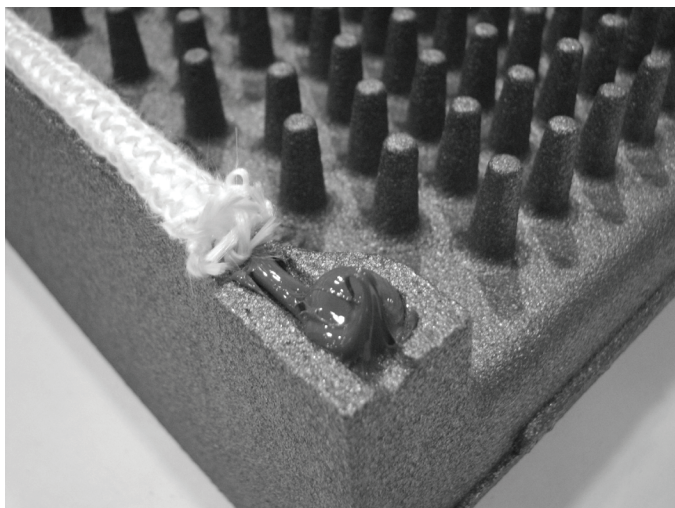

Figure 4b Placing of new silicone in the sockets.



NOTICE Place enough silicone in the socket to make a seal with the mating surface on the adjacent casting when assembled.

Prepare the boiler *(continued)*

Figure 5 Boiler tappings (see Table 4)

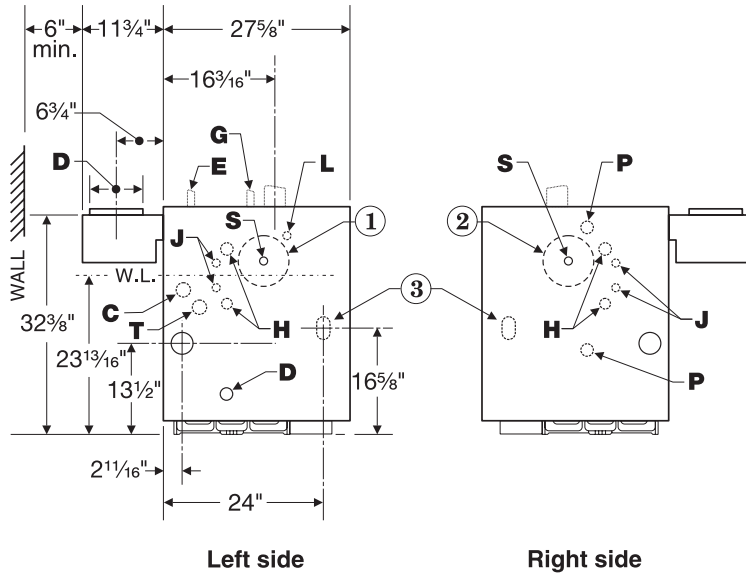

- ① Optional heater for water boiler
- ② Optional heater for water boiler — available only on EGH boilers
- ③ Gas supply entrance — enter on either side of boiler

Table 4 Control tapping (see Figure 5)

Tapping	Size Inches	Steam Boilers	Water Boilers
C	3/4	Probe type low water cut-off	Probe type LWCO (when used)
D	3/4	Drain	Drain
E	3/4	Safety valve	Safety relief valve
G	3/4	Plugged	Piping to compression tank or auto air vent
H	1/2	Gauge glass and/or optional low water cut-off	Combination pressure temperature gauge
J	3/8	Tri cock tappings	Plugged on (Float type LWCO)
L	1/2	Syphon, pressure gauge, high limit (Probe type LWCO)	Combination pressure temperature gauge
P (EGH Only)	1	Float type low water cut-off, pressure limit control and pressure gauge; or low water cut-off and feeder combination; or low water cut-off and pump control	Float type low water cut-off; or low water cut-off and feeder combination; or low water cut-off and pump control
S	1 1/2 3/4 (note 1)	Skim tapping —	Limit control Limit control
T	—	Backup LWCO probe	Backup LWCO probe
Notes:	1. Available on special request only, when tankless heater is specified. 2. Limit control and supply piping must be on the same end of the EGH boiler 3. When an internal type water heater is installed, use the tapping in the heater for an additional operating control.		

Installation of optional indirect water heater

- For a boiler ordered with internal type indirect water heater, remove heater opening cover plate (water boilers – round plate on left side; steam boilers – rectangular plate on front).
- Install heater(s) as shown on page 18. Do not over tighten studs and nuts - damage to the gasket can occur.

Hydrostatic pressure test

Pressure test before attaching gas piping or electrical supply.

- Plug any necessary boiler tappings or openings.
- Do not use gauge supplied with boiler for pressure testing. Install gauge with appropriate range.
- Fill boiler with water. Vent all air. Test steam boilers between 45 - 55 psi. Test water boilers at 1-1/2 times maximum working pressure.

WARNING Do not leave boiler unattended. A cold water fill could expand and cause excessive pressure, resulting in severe personal injury, death or substantial property damage.

- Verify gauge pressure is maintained. Check for leaks. Repair if found.

WARNING Leaks must be repaired at once. Failure to do so can cause boiler damage, resulting in substantial property damage.

DANGER Do not use petroleum-based sealing compounds in boiler system. Severe damage to boiler will result, causing substantial property damage.

- Drain boiler and repair leaks if found.
- Retest boiler after repairing leaks.
- Remove plugs from any tappings that will be used for controls and accessories. Refer to Table 4 and Figure 5.
- On initial start-up check for leaks in the system piping. If found, repair at once.

Prepare the boiler *(continued)*

Installation of flue collector hood

(Factory installed on PEG boilers)

Set flue collector hood on boiler as shown in Figure 6. Use boiler cement furnished to provide gas-tight seal.

⚠ WARNING Failure to maintain gas-tight seal can cause flue gas spillage and carbon monoxide emissions, resulting in severe personal injury or death.

Figure 6 Flue collector hood

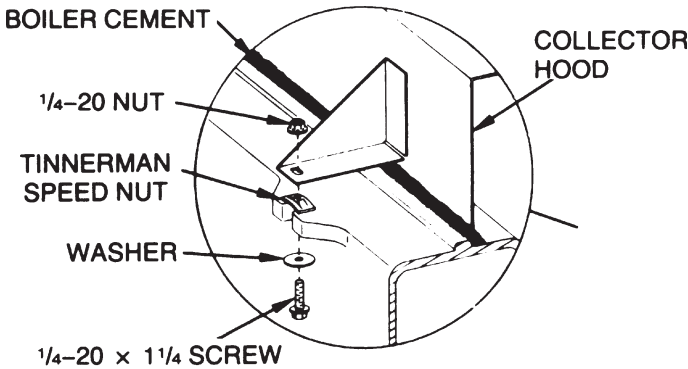

Installation of rear base panels

(Factory installed on PEG boilers)

See Figure 7a. Fasten rear base panel (7 5/16 inch high) and rear base channel to section assembly. Seal with boiler cement along top of insulation panels.

⚠ WARNING Failure to maintain gas-tight seal can cause flue gas spillage and carbon monoxide emissions, resulting in severe personal injury or death.

Figure 7a Rear base panel and base channel

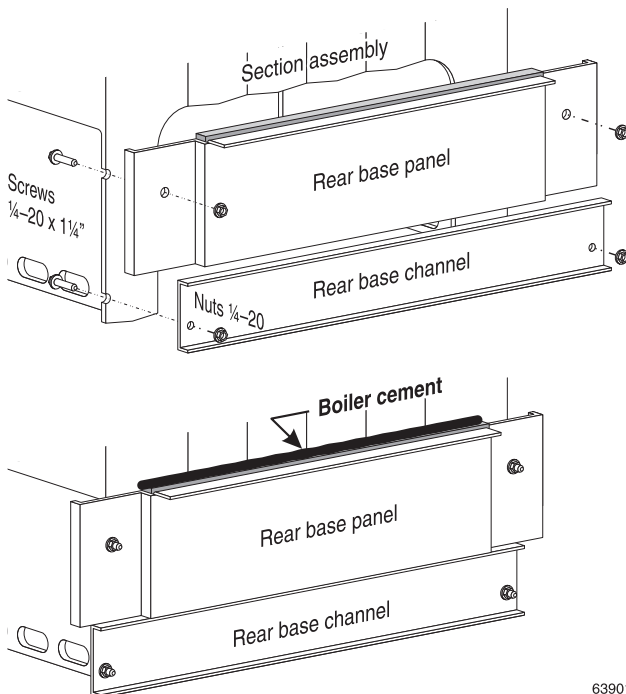

Installation of drawer assembly, front base panels – EG/EGH

(Factory installed on PEG boilers)

1. See Figure 7b. Fasten front base panel (6 1/8 inch high) and rear base channel to section assembly. Seal with boiler cement along top of insulation panels.
2. The burner drawer assembly consists of the burner drawer, main burners, gas manifold, pilot burner, etc.
3. Check for proper orifice sizing from Table 5.

⚠ DANGER Proper orifices must be used. Failure to do so will cause severe personal injury, death or substantial property damage.

4. Place burners in the drawer assembly as shown in Figures 8 and 9.
5. Slide the drawer assembly under the front base panel and attach to the section assembly as shown in Figure 10.
6. Level and straighten burners.

⚠ DANGER Burners must be properly seated in slots in back burner support with openings facing up. Gas orifices must inject down center of burner. Failure to properly seat burners will result in severe personal injury, death or substantial property damage.

7. **EG35 – EG75 only:** Install rollout thermal fuse element with wire terminals facing up on front access panel as shown in Figure 11. Wire per the appropriate Control Supplement.

Table 5 Orifice drill sizes

Orifice Drill Sizes		
Type of Gas	Heating Value BTU/cu. ft.	Standard Orifice drill size
Natural	1,000	2.45 mm
Propane	2,500	1.55 mm

Orifice Drill Sizes - EG - Canada Only		
Elevation	Natural	Propane
0 - 2,000 ft.	2.45 mm	1.55 mm
2,000 - 4,500 ft.	2.30 mm	1.45 mm

Inspect burners – PEG boilers

1. PEG boiler are factory-assembled, but the burners and base panels should be inspected to ensure they are in good condition.
2. Remove the access panel (Figure 11) and inspect the burners per step 6 above. Replace the access panel.

63901

Prepare the boiler (continued)

Figure 7b Front base panel

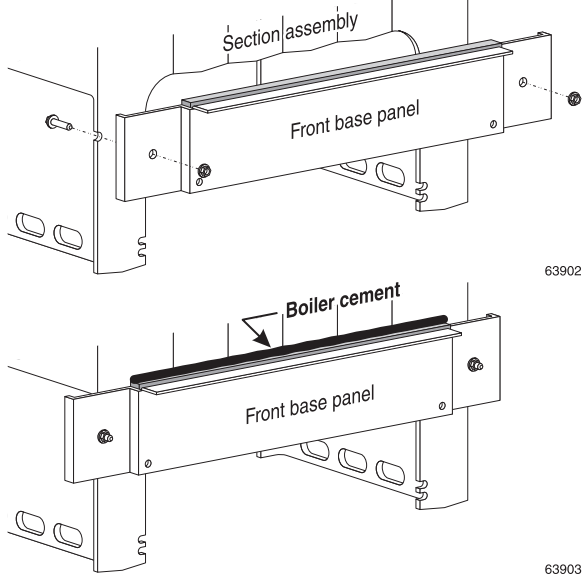

Figure 10 Burner drawer installation

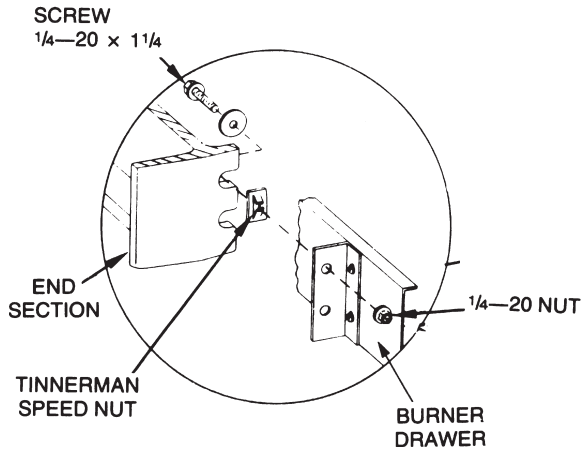

Figure 8 Burner drawer assembly

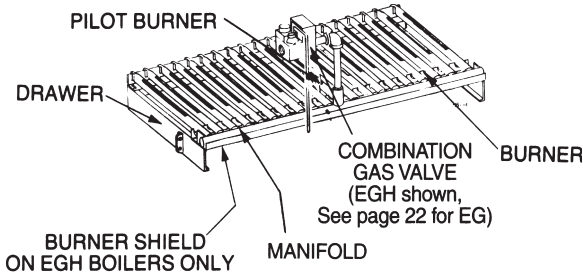

Figure 11 Access panel

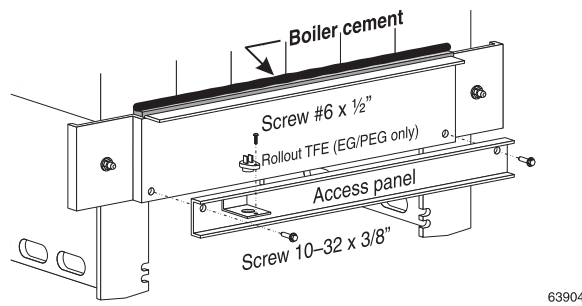
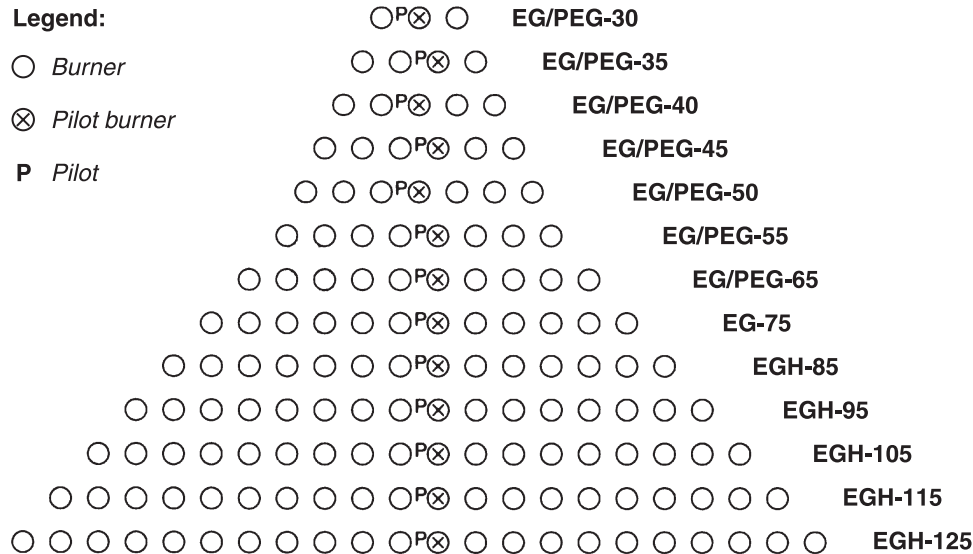

Figure 9 Burner and pilot burner locations



Prepare the boiler *(continued)*

Jacket installation (Factory installed on PEG)

1. Remove the proper knockout discs from panels as shown in Table 4, page 10.

NOTICE Tankless and storage heater knockouts must be removed for EG and EGH boilers with optional tankless heaters prior to jacket installation.

2. Follow Jacket Instructions in jacket carton.

Draft hood installation

Attach draft hood to flue collector hood using #10 x 1/2" sheet metal screws provided. Use boiler cement furnished to provide gas tight seal.

WARNING Failure to maintain gas-tight seal can cause flue gas spillage and carbon monoxide emissions, resulting in severe personal injury or death.

DANGER Do not alter boiler draft hood or place any obstruction or non-approved damper in the breeching or vent system. CSA certification will become void. Flue gas spillage and carbon monoxide emissions will occur causing severe personal injury or death.

Figure 12 Draft hood

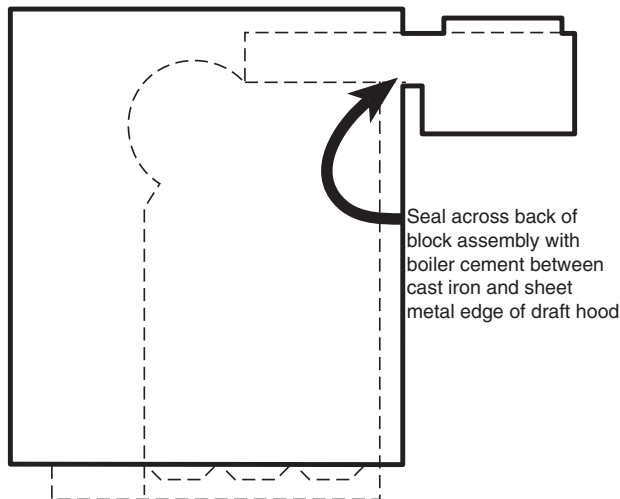

Spill switch installation

EG-30 – EG-75 and PEG-30 – PEG-65 boilers only, fasten spill switch to draft hood as shown on page 34, Drawing Ref. Letter "K". Connect wires as shown in the appropriate Control Supplement.

Damper installation

If damper will be installed, see Control Supplement for information.

Breeching erection

Connect from draft hood or damper outlet to chimney or vent with same size breeching. Where possible, vertical venting to the outside from draft hood or damper outlet will offer best performance. Where horizontal breeching is used, slope upward at least 1/4 inch per lineal foot toward chimney or vent and support with hangers to prevent sagging.

WARNING A vertical height of 3 feet to 5 feet of breeching before any elbow or horizontal breeching is recommended to reduce chances of flue gas spillage at draft hood on EGH-95 thru -125 boilers (not restricted on any EG or EGH-85). Long horizontal breechings, excessive numbers of elbows or tees, or other obstructions which restrict the flow of combustion gases should be avoided.

Breeching must not be connected to any portion of a mechanical draft system operating under positive pressure.

Connect piping – water boilers

General

Install the boiler jacket before connecting return piping. (Supply piping can be connected before or after jacket installation.) Connect controls after all piping is connected.

If installation is to comply with ASME or Canadian requirements, an additional high temperature limit is needed. Install control in supply piping between boiler and isolation valve. Set second control to minimum 20 °F above setpoint of first control. Maximum allowable setpoint is 240 °F. See page 23 for wiring.

A low water cutoff device is required when boiler is installed above radiation level or by certain state or local codes or insurance companies. Use low water cutoff designed for water installations. Electrode probe-type is recommended. Purchase and install in tee supply piping above boiler.

Use backflow check valve in cold water supply if required by local codes.

Near-boiler piping

Boiler connections

1. EG — Connect supply and return to left end.
2. EGH — Connect supply and return to same end, either left or right.
3. Plug all unused connections.

Systems operating at or above 130°F

1. See Table 6 and Figure 14 (diaphragm-type or bladder-type expansion tank) or Figure 13 (closed-type expansion tank) on page 12 for near-boiler piping for systems designed for return water at least 130 °F.

Low-temperature systems

1. See page 16 (Figures 16 and 17) for near-boiler piping for low-temperature or high-volume systems.
2. See page 15 (Figure 15) for boilers used with refrigeration systems.

Relief valve

Install relief valve vertically in $\frac{3}{4}$ " tapping on side of boiler. See the tag attached to the relief valve for manufacturer's instructions.

⚠ WARNING To avoid water damage or scalding due to valve operation, discharge line must be connected to relief valve outlet and run to a safe place of disposal. Terminate the discharge line to eliminate possibility of severe burns should the valve discharge.

- Discharge line must be as short as possible and be the same size as the valve discharge connection throughout its entire length.
- Discharge line must pitch downward from the valve and terminate at least 6" above the floor drain where any discharge will be clearly visible.
- The discharge line shall terminate plain, not threaded, with a material serviceable for temperatures of 375 °F or greater.
- Do not pipe the discharge to any place where freezing could occur.
- No shutoff valve shall be installed between the relief valve and boiler, or in the discharge line. Do not plug or place any obstruction in the discharge line.
- Failure to comply with the above guidelines could result in failure of the relief valve to operate, resulting in possibility of severe personal injury, death or substantial property damage.
- Test the operation of the valve after filling and pressurizing system by lifting the lever. Make sure the valve discharges freely. If the valve fails to operate correctly, replace it with a new relief valve.

Table 6 Minimum recommended pipe sizes

Minimum Recommended Pipe Sizes (for 20°F rise)				
Boiler Number	Forced-flow systems		Gravity-flow systems	
	Supply "A"	Return "B"	Supply "A"	Return "B"
EG-30, 35	1"	1"	1 ½"	1 ½"
EG-40, 45, 50	1 ¼"	1 ¼"	2"	2"
EG-55, 65	1 ½"	1 ½"	2 ½"	2 ½"
EG-75	2"	2"	2 ½"	2 ½"
EGH-85-95	2"	2"		
EGH-105-125	2 ½"	2 ½"		
Note:	* All supply and return pipe sizes are based upon a 20°F temperature rise through the boiler			

Circulator

The circulator is shipped loose (wiring pre-attached to boiler) to allow you to locate it either in the return or supply piping, as desired. See page 12 for a typical installation. Pipe the expansion tank to the suction side of the circulator whenever possible. Install an air separator in the supply piping. Connect the expansion tank to the air separator only if the separator is on the suction side of the circulator. Always install the system fill connection at the same point as the expansion tank connection to the system. Figures 13 and 14 show typical near-boiler piping connections.

Expansion tank

Diaphragm-type or bladder-type tank — Figure 14

1. Ensure expansion tank size will handle boiler and system water volume and temperature. Tank must be located in boiler return piping as close to boiler as possible, before inlet side of circulator. See tank manufacturer's instructions for details.
2. Install an automatic air vent as shown.

Closed-type tank — Figure 13

1. Ensure expansion tank size will handle boiler and system water volume and temperature. See tank manufacturer's instructions for details.
2. Connect tank to $\frac{1}{2}$ " NPT tapping located behind supply outlet, using $\frac{1}{2}$ " NPT piping. Pitch any horizontal piping up towards tank 1 inch per 5 feet of piping.

⚠ CAUTION Undersized expansion tanks cause system water to be lost from relief valve and makeup water to be added through fill valve. Eventual section failure can result.

Water piping — multiple zone systems

Install system piping using either circulator zoning or zone valve zoning. Install expansion tank on suction side of system circulator. Always connect fill line only at the expansion tank — never at another point in the system.

Connect piping – water boilers *(continued)*

Figure 13 Recommended piping – forced hot water boilers with closed type expansion tanks

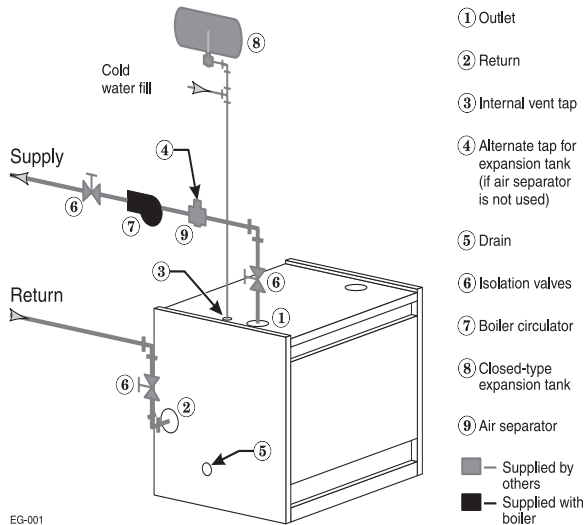
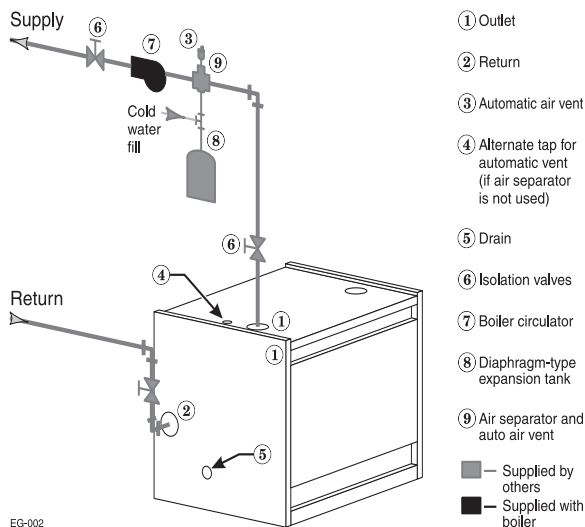

Figure 14 Recommended piping – forced hot water boilers with diaphragm type expansion tanks



WARNING

Use Figure 13 or Figure 14 only for systems designed for return water at least 130 °F. For systems with low return water temperature possible, such as converted gravity systems and radiant heating systems, install bypass piping (see page 16) to protect boiler against condensation. Failure to prevent low return water temperature to the boiler could cause corrosion of the boiler sections or burners, resulting in severe personal injury, death or substantial property damage.

WARNING

If system includes radiant heating circuits, provide piping and controls to regulate the temperature supplying the radiant circuits. Failure to comply could result in substantial property damage.

Water piping – refrigeration systems

Prevent chilled water from entering boiler

Install boiler so that chilled medium is piped in parallel with the heating boiler. Use appropriate valves to prevent chilled medium from entering boiler. See Figure 15 for typical installation of balancing valve and check valve.

WARNING

Install boiler so that chilled medium is piped in parallel with heating boiler (Figure 15). Use appropriate valves to prevent chilled medium from entering boiler. Consult AHRI Installation and Piping Guides.

If boiler is connected to heating coils located in air handling units where they can be exposed to refrigerated air, use flow control valves or other automatic means to prevent gravity circulation during cooling cycle. Circulation of cold water through the boiler could result in damage to the heat exchanger, causing possible severe personal injury, death or substantial property damage.

Figure 15 Recommended piping – refrigeration systems

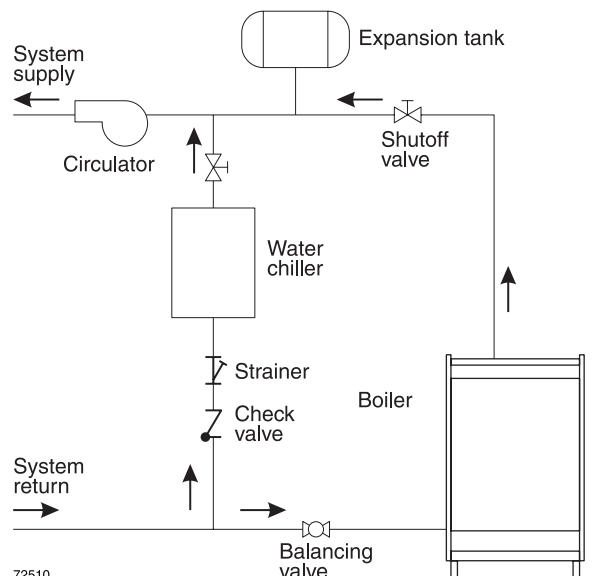

Connect piping – water boilers *(continued)*

Figure 16 System bypass piping in boiler loop with separate system circulator, using primary/secondary piping.

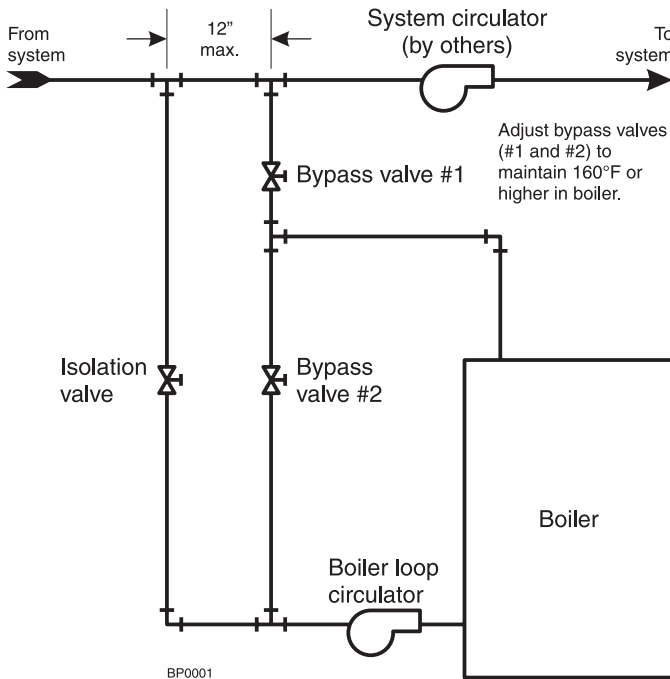

System bypass method

1. Apply bypass piping of Figure 16 to high water content systems, radiant panel systems or any system that is likely to operate with low return water temperature for extended periods.
2. The bypass arrangement shown protects the boiler from damage caused by condensate corrosion due to low return water temperature and protects low temperature systems from too high a supply temperature.
3. Adjust the bypass valves as indicated below.

Adjust Bypass valves 1 and 2 as follows:

1. Start with valve 2 fully closed, valve 1 fully open.
2. Slowly open valve 2 while closing valve 1. Adjust the valves until the boiler pressure/temperature gauge reads 160 °F or higher. As you open the valves, pause long enough to allow temperatures to level off. It takes a while for the boiler water temperature to rise as the flow changes.
3. Bypass valve 2 allows hot boiler outlet water to blend with colder return water, raising the supply temperature to the boiler. Bypass valve 1 balances the pressure drop through valve 2.
4. The purpose of this piping is to raise the return water temperature to the boiler enough to prevent condensation of flue gases.

⚠ WARNING Install all components specified above and adjust valves as described to prevent low temperature in the boiler. Failure to prevent low water temperature in the boiler could cause corrosion of the boiler sections or burners, resulting in severe personal injury, death or substantial property damage.

Figure 17 Boiler bypass piping — use only for high water content systems — DO NOT use for radiant panel systems.

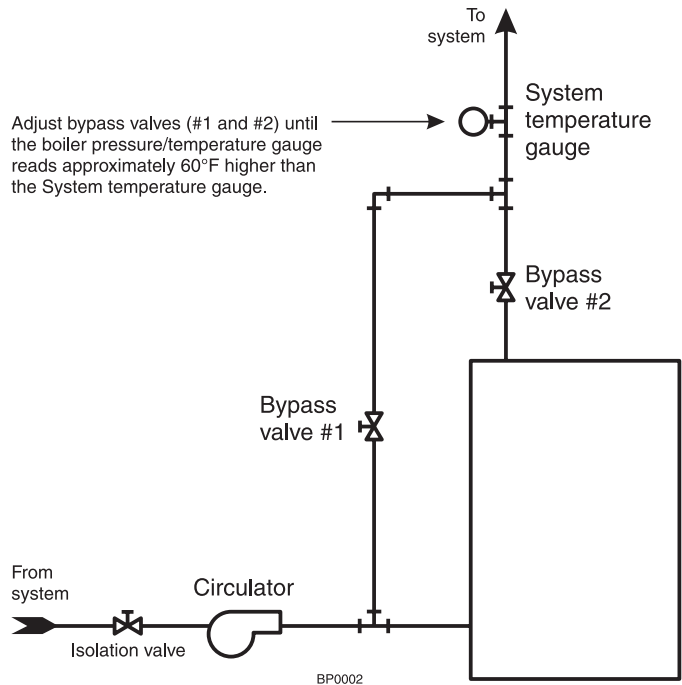

Boiler bypass method

1. Apply bypass piping of Figure 17 to high water content systems, such as converted gravity systems.
2. The bypass arrangement shown protects the boiler from damage caused by condensate corrosion due to low return water temperature. This method does not provide protection from high temperature water being supplied to the system.
3. DO NOT apply this piping to radiant panel systems.
4. Adjust the bypass valves as indicated below.

Adjust Bypass valves 1 and 2 as follows:

1. Start with valve 1 fully closed, valve 2 fully open.
2. Slowly open valve 1 while closing valve 2. Adjust the valves until the boiler pressure/temperature gauge reads approximately 60 °F higher than the system temperature gauge. As you open the valves, pause long enough to allow temperatures to level off. It takes a while for the boiler water temperature to rise as the flow changes.
3. Bypass valve 1 controls system flow rate. Bypass valve 2 controls flow through the boiler.
4. The purpose of this piping is to cause a high enough temperature rise in the boiler that the average temperature will be warm enough to prevent condensation of flue gases.

Connect piping – steam boilers *(continued)*

General

CAUTION Failure to properly pipe the boiler may result in improper operation and damage to the boiler or building.

NOTICE Steam supply must be on same end as controls. Return may be from either end.

1. Install the boiler jacket before connecting return piping. (Supply piping can be connected before or after jacket installation.) Connect controls after all piping is connected.
2. See Table 7 for recommended pipe sizing.
3. See Figure 5, page 10, for tapping locations.
4. EGH only - install 3/4" system blow-off (drain) valve in lowest part of return piping close to boiler.

NOTICE Condensate return —

- Satisfactory operation of a steam heating system depends on adequate condensate return to boiler to maintain a steady water level.
- Avoid adding raw makeup water.
- Where condensate return is not adequate, install low water cutoff/pump control, condensate receiver and condensate boiler feed pump. Refer to Table 5, page 16, for sizing.

Connecting to parallel-flow piping

1. See Figure 18 for parallel-flow steam systems.

Connecting to counterflow piping

When connecting to a counterflow system, the boiler steam supply must connect into the top of the counterflow system header, as shown in Figure 19.

Table 7 Recommended steam boiler pipe sizing

Steam Boiler Piping Minimum Recommended Pipe Sizes				
Boiler Model	Riser Pipe Size		Header * H	Equalizer J
	A	B		
EG-30, 35 PEG-30,35	2"	—	2"	1 1/2"
EG-40, 45, 50 PEG-40, 45, 50	2 1/2"	—	2 1/2"	1 1/2"
	2"	—	2"	1 1/2"
EG-55, 65, 75 PEG-55, 65	3"	—	3"	1 1/2"
EGH-85, 95	2"	2"	3"	1 1/2"
EGH-105	2 1/2"	2 1/2"	3"	1 1/2"
EGH-115, 125	2 1/2"	2 1/2"	4"	1 1/2"
*	24" minimum from waterline to header.			

Figure 18 Recommended piping for parallel-flow systems

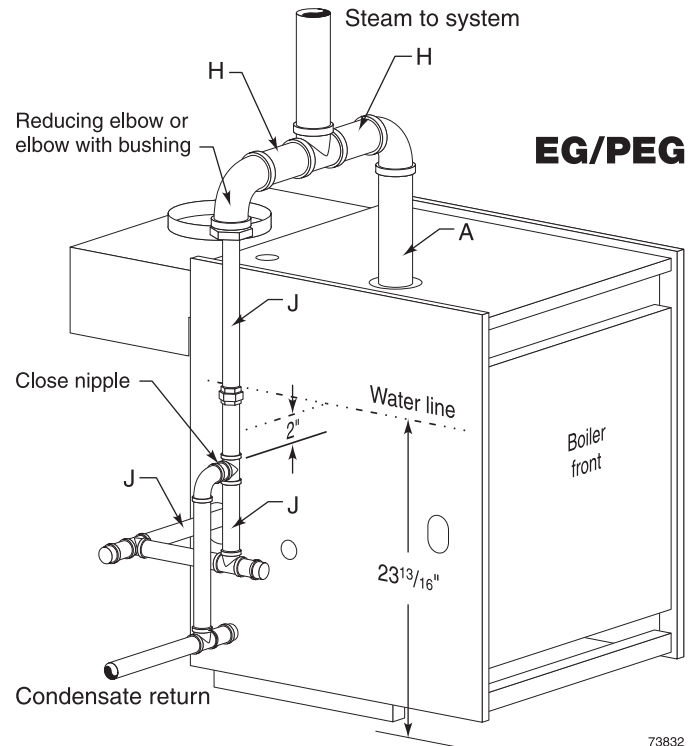

73832

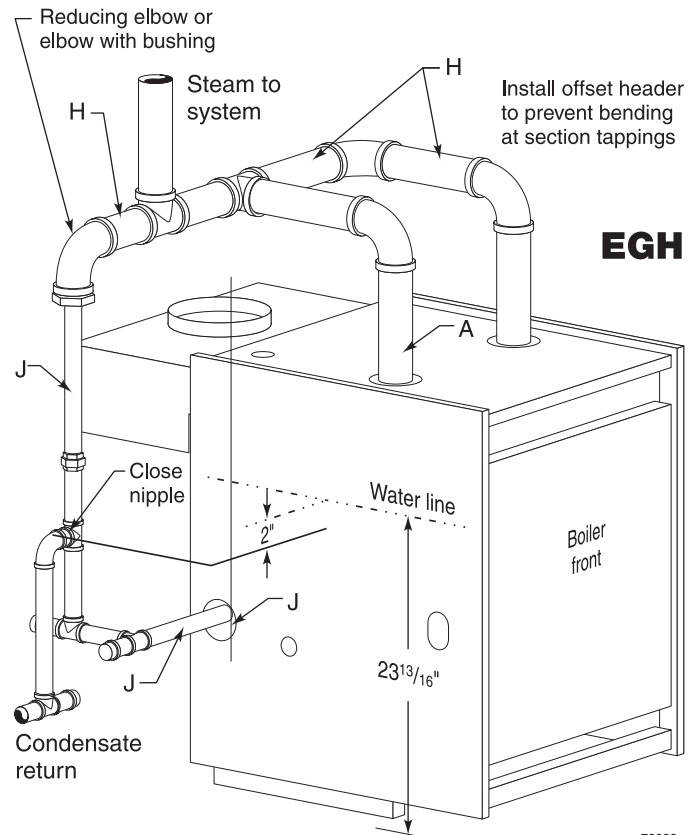

73832a

Connect piping – steam boilers *(continued)*

Figure 19 Connection to counterflow steam piping

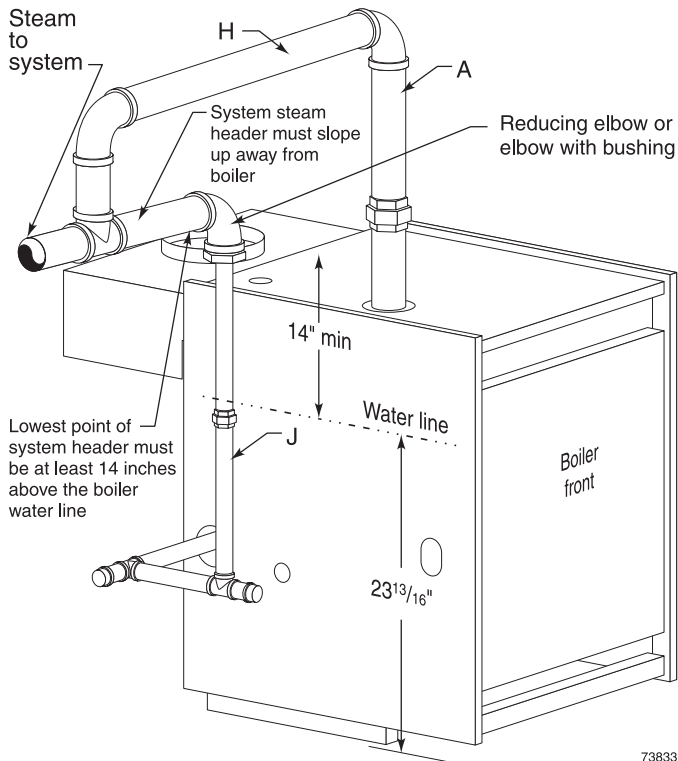

Installing the relief valve

Install relief valve in tapping on top of boiler. See Table 4, page 10, for control tapping locations. See the tag attached to the relief valve for manufacturer's instructions.

⚠ WARNING Follow the steps below to avoid potential severe personal injury, death or substantial property damage.

- When installing the relief valve, ensure that all connections, including the valve inlet, are clean and free from any foreign matter.
- Mount the relief valve only in the vertical position, directly connected to the tapping designated in the manual on top of the boiler.
- Use pipe compound sparingly, or tape, on external threads only.
- Do not use a pipe wrench! Use proper type and size wrench on wrench pads only.

⚠ DANGER During operation, this valve may discharge large amounts of steam and/or hot water. Therefore, to reduce the potential for bodily injury and property damage, a discharge line **MUST** be installed that:

- Is connected from the outlet to a safe point of discharge with no intervening valve.
- Allows complete drainage of both the valve and the discharge line.
- Is independently supported and securely anchored so as to avoid applied stress as possible.
- Terminates freely to atmosphere where any discharge will be clearly visible and is at no risk of freezing.
- Is, over its entire length, of a pipe size equal to or greater than that of the valve outlet.

Use only schedule 40 metal pipe for discharge. (Do not use schedule 80, extra strong or double strong pipe or connections.) **DO NOT CAP, PLUG OR OTHERWISE OBSTRUCT DISCHARGE PIPE OUTLET!** If discharge is piped upward, a condensate drain must be provided in the elbow below the vertical pipe to prevent condensate from returning into the valve. Failure to comply with these instructions will cause a dangerous spray of hot water and steam that would cause severe personal injury or death.

Connect piping – steam boilers *(continued)*

Condensate return

Modern steam boilers are designed to steam for less time than older, larger boilers. When replacing an older steam boiler the system condensate return time may be longer than the steaming time. This could cause the following problems:

1. Boilers fitted with an automatic water feed could overflow.
2. Units fitted with only a low water cutoff would shut down and cycle while waiting for condensate to return.

Following is a simple method for determining whether or not a reservoir pipe is required to lengthen steaming time for a residential installation:

1. Disconnect condensate return line at existing boiler.
2. Heat boiler and allow to steam for 10 minutes. Turn off boiler.
3. Measure length of time from when boiler started to steam to when condensate begins to return through condensate line.
4. Measure length of time from when condensate begins to return to when it stops returning. Divide this time by 2.
5. Add time measured in step 3 to time calculated in step 4. This sum is the average time required for condensate to return to the boiler.
6. If this total time is 10 minutes or less, no reservoir pipe is needed.

If total time for condensate to return to boiler (from step 5) is more than 10 minutes, a reservoir pipe (or boiler feed system) is recommended. See Table 8 and Figure 20 for suggested reservoir pipe size. Install as shown in Figure 20.

For larger systems (as noted in Table 8), use a boiler feed system with a condensate tank and feed pump. You will have to install a low water cutoff/pump control on the boiler to operate the pump. Use Table 9 to size boiler feed systems. See Figure 5, page 10, for tapping locations. (The use of a combination condensate tank and float-controlled condensate return pump is not recommended.)

For most residential installations a reservoir pipe may be all that is necessary to ensure proper operation.

Table 8 Reservoir pipe sizing

Boiler model number	Max. boiler gross output	Time from initial steaming to average condensate return (boiler steaming capacity based on 970 Btu per pound of steam)					
		15 minutes		20 minutes		30 minutes	
		gallons	pipe length (feet)	gallons	pipe length (feet)	gallons	pipe length (feet)
EG/PEG-30,-35	75	¾	¾	1½	1½	3	2½
EG/PEG-40,-45	125	1¼	1¼	2½	2¼	Use boiler feed system	
EG/PEG-50	150	1½	1½	3	2½	Use boiler feed system	
EG/PEG-55	175	1¾	1¾	Use boiler feed system			
EG/PEG-65	225	2½	2	Use boiler feed system			
EG-75	250	2½	2¼	Use boiler feed system			
EGH-85	300	3	2½	Use boiler feed system			
EGH-95 up	Not recommended — Use boiler feed system if needed						
Designed full capacity steaming time of modern boilers is 10 minutes.							

Figure 20 Recommended piping for parallel-flow systems with optional reservoir pipe

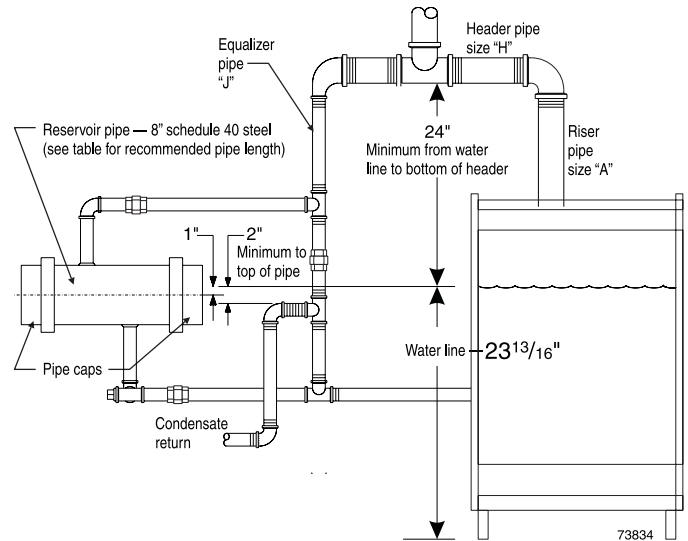

Table 9 Boiler feed/condensate return system sizing

Boiler Model	Gross Output Pounds Steam Per Hour	Gallons Condensate Per Hour	Minimum Condensate Receiver Capacity (Gal.)				Recommended Maximum Feed Pump Capacity GPM *
			Minutes of boiler operation:				
			15	30	45	60	
EG/PEG-30	62	8	2	4	6	8	0.2
EG/PEG-35	83	10	3	6	9	12	0.3
EG/PEG-40	104	12	4	7	11	14	0.4
EG/PEG-45	125	15	5	9	14	18	0.5
EG/PEG-50	145	17	5	10	15	20	0.6
EG/PEG-55	167	20	6	12	18	24	0.7
EG/PEG-65	209	24	7	14	22	29	0.8
EG-75	240	29	9	17	26	35	1.0
EGH-85	280	34	10	20	31	41	1.1
EGH-95	320	38	11	23	34	46	1.3
EGH-105	360	43	13	26	39	52	1.4
EGH-115	400	48	14	29	43	58	1.6
EGH-125	440	53	16	32	48	64	1.8

* If pump capacity exceeds capacity shown, pump can be throttled with globe or ball valve.

Install boiler controls

WARNING Failure to properly install, pipe and wire boiler controls may result in severe damage to the boiler, building and personnel.

Water boiler

1. Install controls as shown on Control Tapping Table and Figure 5, page 10. Limit control and supply piping must be on the same end of EGH boiler.
2. Low water cut off for water boilers:
 - a) Must be installed if boiler is located above radiation level.
 - b) Must be installed on all EGH 105-125 water boilers to meet ASME specifications (low water cut-off not supplied by Weil-McLain).
 - c) May be required on water boilers by certain state, local or territorial codes or insurance companies. If a low water cut-off is used on a water boiler, use a control designed especially for water installations. An electrode probe type may be located in a tee in the supply line above boiler, also see Table 4, page 10.
3. If system is to be ASME inspected and approved, an additional high temperature limit is needed. Purchase and install in supply line above boiler.

Steam boiler

NOTICE Water line dimension are measured from bottom of boiler section leg where it rests on the boiler room floor or boiler foundation.

1. For steam boilers furnished with probe-type low water cut-offs, install as shown in Figure 21.
2. For steam boilers furnished with float type low water cut-off, install controls as illustrated in Figure 22.

Install blowdown line in bottom of cutoff. See Figure 22 and control manufacturer's instructions for details.

WARNING Pipe blowdown line near floor close to floor drain to eliminate potential of severe burns. Do not plug, valve or place any obstruction in blowdown line.

- a) Other float-type water-level controls for EGH steam boilers are shown in Figure 23. (Use 1 inch I.P.S. connections).
 - b) Water feeders are not recommended for primary control. A low-water cut-off with pump controller is recommended with a condensate receiver and feed pump.
3. Install remaining controls as shown in Table 4 and Figure 5, page 10.

Figure 21 Probe-type low water cut-off

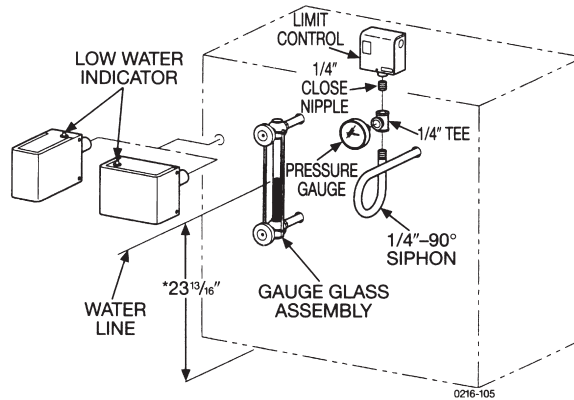

Figure 22 Float-type low water cut-off

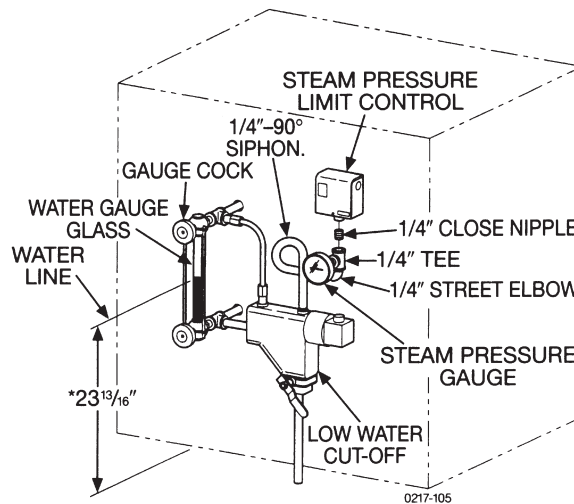
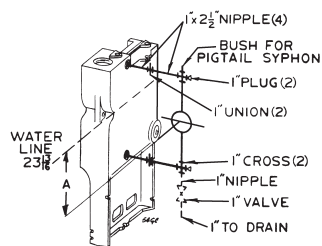

Figure 23 Piping for optional float-type water level controllers for steam boilers



L.W.C.O.	Dim A.
No. 247-2	1 3/16"
No. 61	2 5/8"
No. 63	2 5/8"
No. 51-2	1 1/2"
No. 150, 157	2 1/4"
No. 93	2 5/8"

NOTICE LWCO model numbers are manufacturer's part numbers that can be found in the Weil-McLain Trade Price Schedule.

Connect piping – tankless heater (optional)

NOTICE EG and EGH boilers for tankless heater application are available only on special order as factory-installed optional equipment. Standard boilers cannot be adapted for heater use. Install a tankless heater only in a steam boiler or forced hot water.

For correct operation, install as shown in Figure 24 (water boilers) or Figure 25 (steam boilers).

1. Automatic mixing valve must be installed per mixing valve manufacturer's instructions.
2. Flow regulating valve must be installed. Size according to intermittent draw of heater as shown in following table.
3. Operating control with a small differential scale is recommended. Install in temperature control tapping in heater plate.
4. In hard water areas, it is advisable to soften cold domestic supply water to the tankless heater to prevent lime buildup.

Figure 24 Tankless heater piping (water boiler)

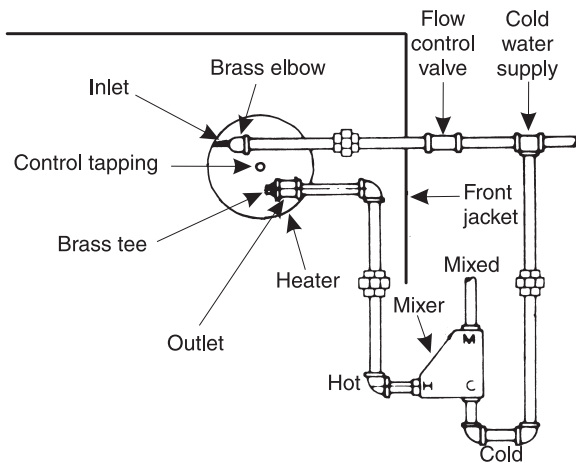

NOTICE Piping Connections not furnished. Use brass plugs in tees and crosses to facilitate cleaning in hard water areas.

Figure 25 Tankless heater piping (steam boiler)

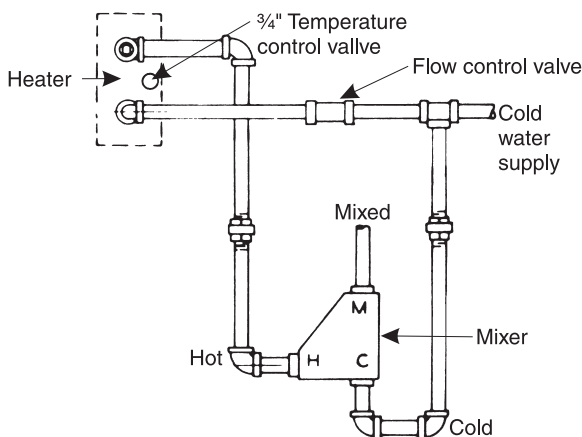

Table 10 Minimum recommended pipe sizes

Boiler Model	Heating Number (Note 3)	Intermittent Draw GPM 100°F Av. Temp. Rise (Note 1)	Continuous Draw GPM 100°F Av. Temp. Rise (Note 2)	Inlet and Outlet Tappings	Temp. Control Tapping
Water					
EG-35	E-624	3.00	1.60	½"	¾"
EG-40	E-624	3.00	2.00	½"	¾"
EG-45	E-624	3.25	2.40	½"	¾"
EG-50	E-626	4.00	2.80	½"	¾"
EG-55	E-626	4.25	3.20	½"	¾"
EG-65	E-632	4.50	4.00	½"	¾"
EG-75 (Note 5)	E-632	4.50	4.80	½"	¾"
EGH-85 (Notes 4 & 6)	E-632	5.50	5.60	½"	¾"
EGH-95 (Note 4)	E-632	5.50	5.55	½"	¾"
EGH-105	E-632	5.75	5.75	½"	¾"
EGH-115	E-632	6.00	6.00	½"	¾"
EGH-125	E-632	6.00	6.00	½"	¾"
Steam					
EG/PEG-35	35-S-29	3.00	1.60	¾"	¾"
EG/PEG-40	35-S-29	3.00	2.00	¾"	¾"
EG/PEG-45	35-S-29	3.25	2.40	¾"	¾"
EG/PEG-50	35-S-29	3.25	2.80	¾"	¾"
EG/PEG-55	35-S-29	3.50	3.20	¾"	¾"
EG/PEG-65	35-S-29	3.75	4.00	¾"	¾"
EG-75	35-S-29	4.00	4.80	¾"	¾"
EGH-85	35-S-29	4.00	5.00	¾"	¾"
EGH-95	35-S-29	4.00	5.00	¾"	¾"
EGH-105	35-S-29	4.00	5.00	¾"	¾"
EGH-115	35-S-29	4.00	5.00	¾"	¾"
EGH-125	35-S-29	4.00	5.00	¾"	¾"
NOTES	Weil-McLain ratings based on 60 PSIG domestic water pressure at heater.				
	1. Gallons of water per minute heated from 40°F to 140°F with 200°F boiler water temperature.				
	2. Continuous draw – no recovery period.				
	3. These single wall heat exchangers comply with National Standard Plumbing Code provided that:				
	<ul style="list-style-type: none"> • boiler water (including additives is practically non toxic, having a toxicity range or class of 1, as listed in Clinical Toxicology of Commercial Products, and • boiler water pressure is limited to max. 30 psig by approved water or steam relief valve. 				
	4. EGH-85 & 95 Standing pilot systems - no tankless option 5. EG-75 Standing pilot systems - no tankless option 6. EGH-85 Water - use one heater only.				

Connect gas supply piping

Connecting gas supply piping

1. Size gas piping considering:
 - a) Diameter and length of gas supplying piping.
 - b) Number of fittings.
 - c) Maximum gas consumption (including any possible future expansion).
 - d) Allowable loss in gas pressure from gas meter outlet to boiler. For pressure drops, see ANSI Z223.1. Canadian installations must comply with CAN/CSA B149.1 or B149.2 Installation Codes.
2. For natural gas:
 - a) Refer to Table 11 or the National Fuel Gas Code. To obtain cubic feet per hour, divide the input by 1000.
 - b) Size for rated boiler input.
 - c) Inlet gas pressure: 5" w.c. minimum
13" w.c. maximum
 - d) Manifold gas pressure: 3½" w.c.
 - e) Install 100% lock-up gas pressure regulator in supply line if inlet pressure exceeds 13" w.c., then adjust for 13" w.c. maximum.
3. For propane gas:
 - a) Inlet gas pressure: 11" w.c. minimum
13" w.c. maximum
 - b) Manifold gas pressure: 10" w.c.
 - c) Gas pressure regulator provided by gas supplier must be adjusted for maximum pressure of 13" w.c.
 - d) Contact gas supplier to size pipes, tanks and regulator.
4. Remove knock-out disc from jacket panel which gas supply is to be piped.

5. Follow good piping practices.
6. Pipe joint compound (pipe dope) must be resistant to corrosive action of liquified petroleum gases. Apply sparingly only to make threads of pipe joints.
7. Install drip leg at inlet of gas connection to boiler. Where local utility requires, extend drip leg to floor.
8. Install ground joint union when required for servicing. See Figure 26.
9. Install manual shut-off valve outside boiler jacket as shown in Figure 26 when required by local codes.
10. Support piping by hangers, not by boiler or its accessories.
11. In Canada only, the manual main shut off valve (when used) must be identified by the installer.
12. Purge all air from piping.
13. Before placing boiler in operation, check boiler and its gas connection for leaks.

WARNING Do not check for gas leaks with an open flame – use bubble test. Failure to do so can cause severe personal injury, death or substantial property damage.

- a) Close manual main shut-off valve during any pressure testing at less than 13 inches water column.
- b) Disconnect boiler and gas valve from gas supply piping during any pressure test greater than 13 inches water column.

Table 11 Gas pipe capacities

Adjusted length of gas supply piping in feet *	Capacity of pipe sizes in cubic feet of gas per hour **					
	½"	¾"	1"	1 ¼"	1 ½"	2"
10	132	278	520	1,050	1,600	3,050
20	92	190	350	730	1,100	2,100
30	73	152	285	590	890	1,650
40	63	130	245	500	760	1,450
50	56	115	215	440	670	1,270
75	45	93	175	360	545	1,020
100	38	79	150	305	460	870
150	31	64	120	250	380	710
Notes	* Include measured length of gas supply piping and allowance in feet for number and size of fittings. ** Specific Gravity - 0.60; Pressure Loss - 0.30" w.c.					

Figure 26 Gas supply piping

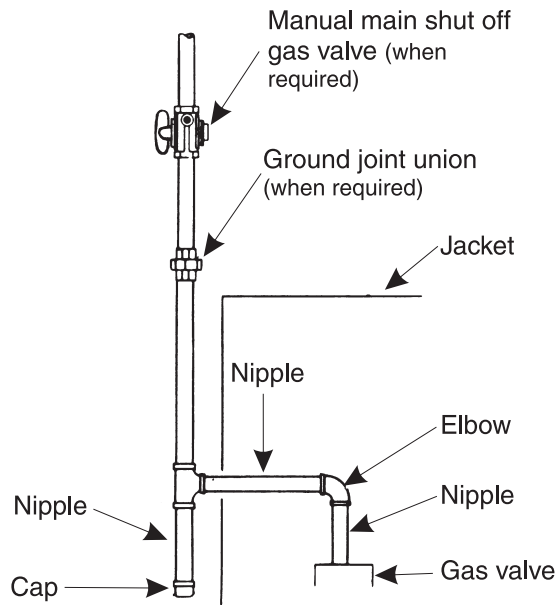

Connect field wiring to boiler

WARNING For your safety, turn off electrical power supply at service entrance panel before making any electrical connections to avoid possible electric shock hazard. Failure to do so can cause severe personal injury or death.

NOTICE Refer to the Control Supplement for additional information, lighting instructions and control wiring diagram.

Wiring must be N.E.C. Class 1.

If rollout thermal fuse element wire supplied with boiler must be replaced, type 200 °C wire or equivalent must be used. If other original wiring supplied with boiler must be replaced, use only type 105 °C wire or equivalent.

Boiler must be electrically grounded as required by National Electrical Code ANSI/NFPA 70—latest edition.

Electrical installation must comply with:

1. National Electrical Code and any other national, state, provincial or local codes or regulations.
2. In Canada, CSA C22.1 Canadian Electrical Code Part 1, and any local codes

Wiring connections

1. Boiler is shipped with controls completely wired, except spill switch and vent damper. See wiring diagram in Control Supplement for details.
2. Installer must attach wiring diagram inside jacket door.
3. See Figure 26 for field wiring. A separate 120 VAC electrical circuit with a fused disconnect switch (15 amp recommended) should be used for the boiler.

4. A strain relief bushing and adapter must be used at each point where wiring passes through control case (see Figure 27) to protect wiring insulation.
5. Multiple zones — Refer to zone valve manufacturer’s literature for wiring and application. A separate transformer is required to power zone valves. Zoning with circulators requires a relay for each circuit.

Room thermostat

1. Connect thermostat as shown on wiring diagram on boiler.
2. Install on inside wall away from influences of drafts, hot or cold water pipes, lighting fixtures, television, sunrays or fireplaces.
3. If thermostat has a heat anticipator, set heat anticipator in thermostat to match power requirements of equipment connected to it. Refer to the appropriate Control Supplement for instructions on the thermostat anticipator setting.

Figure 27 Provide strain relief

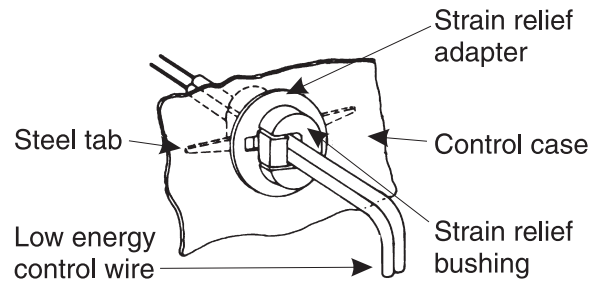
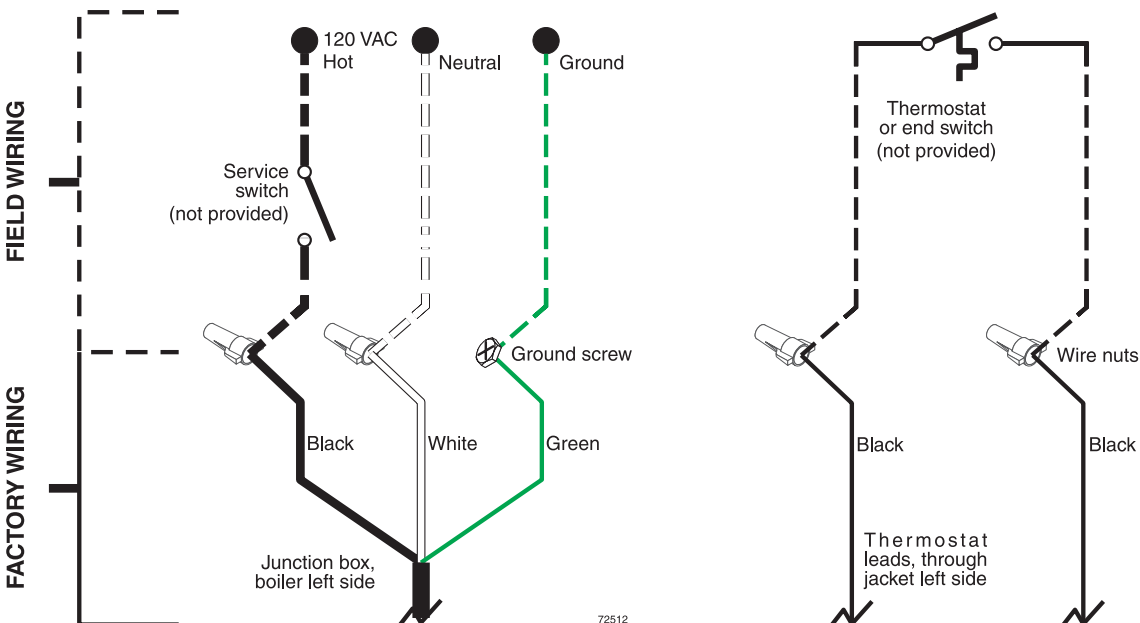

Figure 26 Connect field wiring in boiler junction box as shown below. See Control Supplement for more details.



Start-up

Check for gas leaks

▲WARNING Before starting the boiler, and during initial operation, smell near the floor and around the boiler for gas odorant or any unusual odor. Do not proceed with start-up if there is any indication of a gas leak. Repair any leak at once.

▲WARNING Propane boilers only — Your propane supplier mixes an odorant with the propane to make its presence detectable. In some instances, the odorant can fade and the gas may no longer have an odor.

- Propane gas can accumulate at floor level. Smell near the floor for the gas odorant or any unusual odor. If you suspect a leak, do not attempt to light the pilot.
- Use caution when attempting to light the propane pilot. This should be done by a qualified service technician, particularly if pilot outages are common.
- Periodically check the odorant level of your gas.
- Inspect boiler and system at least yearly to make sure all gas piping is leak-tight.
- Consult your propane supplier regarding installation of a gas leak detector. There are some products on the market intended for this purpose. Your supplier may be able to suggest an appropriate device.

Fill the system

NOTICE Do not fill (except for leakage tests) until the boiler is ready to be fired.

Determine if water treatment is needed

▲DANGER Do not use petroleum-based cleaning or sealing compounds in boiler system. Severe damage to boiler will occur, resulting in substantial property damage.

▲WARNING Eliminate all system leaks. Continual fresh makeup water will reduce boiler life. Minerals can build up in sections, reducing heat transfer, overheating cast iron, and causing section failure.

Consult local water treatment companies for unusually hard water areas (above 7 grains hardness) or low pH water conditions (below 7.0). Boiler water pH of 7.0 to 8.5 is recommended.

Freeze protection (when used)

Use antifreeze especially made for hydronic systems. Inhibited propylene glycol is recommended.

▲WARNING Do not use automotive, ethylene glycol or undiluted antifreeze. Severe personal injury, death or substantial property damage can result.

A 50% glycol solution provides protection to about -30°F.

Local codes may require back-flow preventer or actual disconnect from city water supply.

Determine quantity according to system water content. Boiler water content is listed on page 38. Remember to add in expansion tank water content.

Follow antifreeze manufacturer's instructions.

Filling water systems

1. Close manual air vents, drain cock, and automatic air vent, if used.
2. Fill to correct system pressure. Correct pressure will vary with each application. Residential systems are often designed for 12 psig of cold fill pressure.
3. Open automatic air vent one turn, if used.
4. Open manual water feed valve.
 - a) Starting on lowest floor, open air vents one at a time until water squirts out. Close vent.
 - b) Repeat with remaining vents.
5. Close manual water feed valve when correct boiler pressure is reached.
6. If purge valve is used - located in the return piping above isolation valve:
 - a) Connect hose to purge valve.
 - b) Close isolation valve. Open purge valve.
 - c) Open hand water feed valve and allow system to purge all air. If system has more than one circuit, purge each circuit separately by opening each balancing valve one at a time.
 - d) Close purge valve and water feed valve cock.
 - e) Open isolation valve.
 - f) Fill system to correct pressure.

Filling steam boilers

1. Fill to normal waterline, halfway up gauge glass.
2. Boiler water pH 7.0 to 8.5 is recommended.
3. Follow skimming procedure.

Start-up *(continued)*

Skim the steam boiler

NOTICE

Clean all newly installed steam boilers to remove oil and grease. Failure to properly clean can result in violent fluctuations of water level, water passing into steam mains or high maintenance costs on strainers, traps and vents.

▲ DANGER

Do not use petroleum-based cleaning or sealing compounds in boiler system. Severe damage to boiler will occur, resulting in substantial property damage.

1. Provide 1½" piping from skim tapping to floor drain.
2. Adjust waterline to midpoint of skim tapping. See Figure 5, page 10.
3. Follow "Lighting Instructions" in the Control Supplement to fire boiler to maintain temperature below steaming rate.
4. Feed in water to maintain water level. Cycle burners to prevent rise in steam pressure.
5. Continue skimming until discharge is clear. May take several hours.
6. Drain boiler. While boiler is warm, but not hot, flush all interior surfaces under full pressure until drain water runs clear.
7. Remove skim piping. Plug tapping.
8. Close drain cock. Fill with fresh water to waterline. Start burners and steam for 15 minutes to remove dissolved gases. Stop burners.
9. Check traps and air vents for proper operation.
10. Process may need to be repeated after several weeks of operation.

Inspect base insulation

▲ WARNING

The boiler contains ceramic fiber and fiberglass materials. Use care when handling these materials per instructions on page 28 of this manual. Failure to comply could result in severe personal injury.

Check to make sure insulation is secure against all four sides of the base. If insulation is damaged or displaced, do not operate boiler. Replace or reposition insulation.

▲ WARNING

Failure to replace damaged insulation or reposition insulation can result in a fire hazard, causing severe personal injury, death or substantial property damage.

Operate boiler

Check system and boiler

▲ WARNING

DO NOT proceed with boiler operation unless boiler and system have been filled with water and all instructions and procedures of previous manual sections have been completed. Failure to do so could result in severe personal injury, death or substantial property damage.

Before starting the boiler . . .

- See Control Supplement for "Lighting Instructions".
- Verify the boiler and system water level is correct (Steam — no more than ½ of gauge glass or less than ¼" above bottom of gauge glass).
- Verify the "Preparation" procedures on the previous pages have been completed.

Start the boiler

1. Steam boilers — Check boiler water level — Should be approximately ½ way up gauge glass.
2. Remove boiler jacket door and note the gas valve manufacturer and model number.
3. Follow the Lighting or Operating Instructions in the Control Supplement, depending on gas valve installed in boiler. Use only the Lighting or Operating Instruction which applies to this gas valve. (The Lighting or Operating Instruction label on the boiler provides the same information.)
4. If boiler fails to start, see "If boiler doesn't start . . . Check for:" on the next page.

Check system and boiler

▲ WARNING

Eliminate all system leaks. Continual fresh makeup water will reduce boiler life. Minerals can build up in sections, reducing heat transfer, overheating cast iron, and causing section failure.

▲ WARNING

If you discover evidence of any gas leak, shut down the boiler at once. Find the leak source with bubble test and repair immediately. Do not start boiler again until corrected. Failure to comply could result in severe personal injury, death or substantial property damage.

▲ DANGER

Do not use petroleum-based cleaning or sealing compounds in boiler system. Severe damage to boiler will occur, resulting in substantial property damage.

1. Check system piping for leaks. If found, shut down boiler and repair immediately.
2. Inspect vent system thoroughly for signs of deterioration from corrosion, physical damage or sagging. Verify that masonry chimney liners are in good condition, with no obstructions, and there are no openings into the chimney.
3. Check around the boiler for gas leaks following the procedure of step 13, page 22.
4. Verify operation using procedures below. Perform "Checkout procedure", page 27, and fill in the "Installation and Service Certificate".

Start-up *(continued)*

If boiler doesn't start . . . Check for:

1. Loose connections, blown fuse or service switch off?
2. High limit switch set below boiler pressure?
3. Thermostat set below room temperature?
4. Gas not turned on at meter or boiler?
5. Incoming gas pressure less than:
5" w.c. for natural gas? 11" w.c. for propane gas?
6. If none of the above corrects the problem, see "Troubleshooting" in the Control Supplement.

Verify operation

Check burner flame — Pilot burner

1. Proper pilot flame (see Figure 28):
 - a. Blue flame.
 - b. Inner cone engulfing thermocouple.
 - c. Thermocouple glowing cherry red.
2. Proper pilot flame:
 - a. Overfired — Large flame lifting or blowing past thermocouple.
 - b. Underfired — Small flame. Inner cone not engulfing thermocouple.
 - c. Lack of primary air — Yellow flame tip.
 - d. Incorrectly heated thermocouple.

Check burner flame — Main burner

1. Proper main burner flame (see Figure 29):
 - a. Yellow-orange streaks may appear (caused by dust).
2. Improper main burner flame:
 1. Overfired — Large flames.
 2. Underfired — Small flames.
 3. Lack of primary air — Yellow tipping on flames (sooting will occur).

Check vent damper operation

1. Raise room thermostat to call for heat — Vent damper actuator will slowly open vent damper.
2. When vent damper is fully open — Main gas valve will open and main burners will ignite.

⚠ DANGER Vent damper must be fully open before main burners light. If vent damper does not fully open, flue products such as carbon monoxide will escape into house, causing severe personal injury or death.

3. Lower thermostat setting — Main burner flames will go out, then vent damper will close.

Figure 28 Typical pilot burner flame

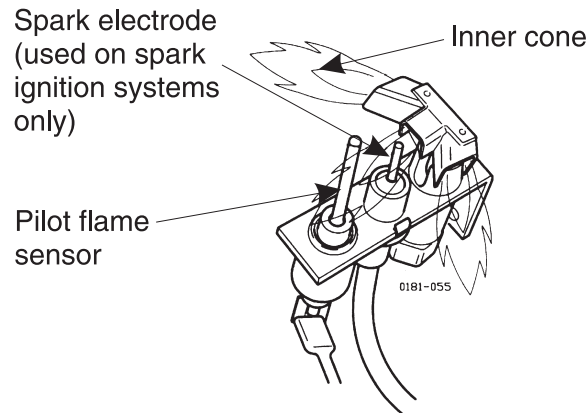
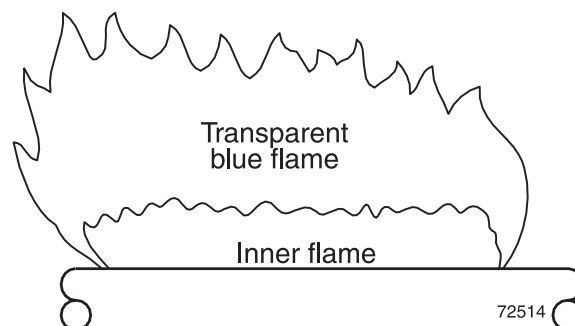

Figure 29 Typical main burner flame



4. Repeat Steps 2 through 4 several times to verify operation.
5. Return thermostat to normal setting.
6. Set thermostat heat anticipator setting indicated on wiring diagram.

Check venting system operation

With boiler firing, hold a candle or match below lower edge of draft diverter "skirt." If flame does not blow out, but burns undisturbed, the vent system is working properly. If flame blows out or flickers severely, the vent system must be checked for obstructions or other causes of improper venting.

Start-up *(continued)*

Check-out procedure

Check-off steps as completed.

- System properly filled with water?
- Automatic air vent, if used, open one turn (water boilers only)?
- Air purged from system (water boilers only)?
- Steam boilers properly skimmed?
- Air purged from gas piping? Piping checked for leaks?
- Are proper orifices installed? Check page 11 for proper size.

▲ DANGER Proper orifices must be used. Failure to do so will cause severe personal injury, death or substantial property damage.

- Follow operating instruction label on boiler for proper start-up. Also refer to “Operate boiler,” page 25.
- Proper burner flame? See “Check burner flame — Main burner” and “Check burner flame — Pilot burner,” page 26.
- Test limit control: While burners are operating, move limit control indicator below actual boiler water temperature or pressure. Burners should go off. Circulator should continue to operate (water boilers only). Raise indicator above boiler water temperature or pressure and burners should reignite.
- Test any additional field-installed controls: If boiler has low water cut-off, additional high limit or other controls, test for operation as outlined by manufacturer. Burners should be operating and should go off when controls are tested. When controls are restored, burners should reignite.
- EG only - button on spill switch pushed in?
- To test ignition system shut-off device:
 - a. For boilers with electronic ignition systems: Connect manometer to outlet side of gas valve. Start boiler, allowing for normal start-up cycle to occur and main burners to ignite. With main burners on, manually shut off gas supply at manual main shut-off gas valve. Burners should go off. Open manual main shut-off gas valve. Manometer should confirm there is no gas flow. Pilot will relight, flame sensing element will sense pilot flame and main burners reignite.

- b. For standing pilot - Turn gas cock knob to PILOT position and extinguish pilot flame. Pilot gas flow should stop in less than 3 minutes. Put system back into operation (see page 23).
- Limit control set to design temperature or pressure requirements of system? Maximum limit setting - 240°F (water boilers) - 15# (steam boilers).
- For multiple zones, flow adjusted so it is about the same in each zone (water boilers only)?
- Thermostat heat anticipator set properly? Refer to “Room Thermostat,” page 20 and correct wiring diagram.
- Boiler cycled with the thermostat? Raise to highest setting. Boiler should go through normal start-up cycle. Lower to lowest setting. Boiler should go off.
- Measure gas input (natural gas only):
 - a. Operate boiler 10 minutes.
 - b. Turn off other appliances.
 - c. At the natural gas meter, measure time (in seconds) required to use one cubic foot of gas.
 - d. Calculate gas input:

$$\frac{3600 \times 1000}{\text{number of seconds from step c}} = \text{Btuh}$$
 - e. Btuh calculated should approximate input rating on rating label.
- Check manifold gas pressure by connecting a manometer to the downstream test tapping on main gas valve.

MANIFOLD GAS PRESSURE
 NAT. = 3.5" w.c.
 L.P. = 10.0" WC.
- Several operating cycles observed for proper operation? If damper is provided, see Control Supplement for check-out procedure.
- Room thermostat set to desired temperature?
- Installation and Service Certificate on this page completed?
- All instructions shipped with this boiler reviewed with owner or maintenance person, returned to envelope and given to owner or displayed near boiler?

Installation and Service Certificate

Boiler Model _____ Series _____ CP Number _____ Date Installed _____

- BTU Input _____
- Installation instructions have been followed.
 - Check-out sequence has been performed.
 - Above information is certified to be correct.
 - Information received and left with owner/maintenance person.

Installer _____
 (Company) (Address) (Phone) (Installer's Signature)

Handling fiberglass and ceramic fiber materials

REMOVAL OF COMBUSTION CHAMBER LINING OR BASE PANELS

▲WARNING

The combustion chamber lining or base insulation panels in this product contain ceramic fiber materials. Ceramic fibers can be converted to cristobalite in very high temperature applications. The International Agency for Research on Cancer (IARC) has concluded, “Crystalline silica inhaled in the form of quartz or cristobalite from occupational sources is carcinogenic to humans (Group 1).”:

- Avoid breathing dust and contact with skin and eyes.
 - Use NIOSH certified dust respirator (N95). This type of respirator is based on the OSHA requirements for cristobalite at the time this document was written. Other types of respirators may be needed depending on the job site conditions. Current NIOSH recommendations can be found on the NIOSH web site at <http://www.cdc.gov/niosh/homepage.html>. NIOSH approved respirators, manufacturers, and phone numbers are also listed on this web site.
 - Wear long-sleeved, loose fitting clothing, gloves, and eye protection.
- Apply enough water to the combustion chamber lining or base insulation to prevent airborne dust.
- Remove combustion chamber lining or base insulation from the boiler and place it in a plastic bag for disposal.
- Wash potentially contaminated clothes separately from other clothing. Rinse clothes washer thoroughly.

NIOSH stated First Aid.

- Eye: Irrigate immediately.
- Breathing: Fresh air.

REMOVAL OF FIBERGLASS WOOL — OR —

INSTALLATION OF FIBERGLASS WOOL, COMBUSTION CHAMBER LINING OR BASE PANELS:

▲WARNING

This product contains fiberglass jacket insulation and ceramic fiber materials in combustion chamber lining or base panels in gas fired products. Airborne fibers from these materials have been listed by the State of California as a possible cause of cancer through inhalation.

- Avoid breathing dust and contact with skin and eyes.
 - Use NIOSH certified dust respirator (N95). This type of respirator is based on the OSHA requirements for fiberglass wool at the time this document was written. Other types of respirators may be needed depending on the job site conditions. Current NIOSH recommendations can be found on the NIOSH web site at <http://www.cdc.gov/niosh/homepage.html>. NIOSH approved respirators, manufacturers, and phone numbers are also listed on this web site.
 - Wear long-sleeved, loose fitting clothing, gloves, and eye protection.
- Operations such as sawing, blowing, tear out, and spraying may generate airborne fiber concentration requiring additional protection.
- Wash potentially contaminated clothes separately from other clothing. Rinse clothes washer thoroughly.

NIOSH stated First Aid.

- Eye: Irrigate immediately.
- Breathing: Fresh air.

Service and maintenance

Table 12 Service and maintenance schedules (service technician and owner)

Service technician (see following pages for instructions)		Owner maintenance (see User's Information Manual for instructions)		
ANNUAL START-UP	<input type="checkbox"/> Inspect: <ul style="list-style-type: none"> • Reported problems • Boiler area • Air openings • Flue gas vent system • Pilot and main burner flames • Piping • Boiler heating surfaces • Burners and base 	<input type="checkbox"/> Daily <ul style="list-style-type: none"> • Check boiler area • Check boiler pressure gauge • Check air openings 		
	<input type="checkbox"/> Service: <ul style="list-style-type: none"> • Gauge glass 	<input type="checkbox"/> Monthly <ul style="list-style-type: none"> • Check boiler and system piping • Check venting system • Check/operate boiler relief valve • Check pilot and main burner flames 		
	<input type="checkbox"/> Start-up: <ul style="list-style-type: none"> • Perform start-up per manual 	<input type="checkbox"/> Periodically <ul style="list-style-type: none"> • Test low water cutoff 		
	<input type="checkbox"/> Check/test: <ul style="list-style-type: none"> • Gas piping • Boiler waterline • Limit controls and cutoffs • Boiler relief valve 	<input type="checkbox"/> End of season <ul style="list-style-type: none"> • Shut down procedure 		
	<input type="checkbox"/> Review: <ul style="list-style-type: none"> • Review with owner 			

▲WARNING Follow the “Service and maintenance” procedures given throughout this manual, the Control Supplement and in component literature shipped with the boiler. See “Read this page first” on page 2. Failure to perform the service and maintenance could result in damage to the boiler or system. Failure to follow the directions in this manual and component literature could result in severe personal injury, death or substantial property damage.

▲WARNING Label all wires prior to disconnection when servicing controls. Wiring errors can cause improper and dangerous operation.

▲WARNING To avoid personal injury, death or property damage, keep boiler area clear and free from combustible materials, gasoline and other flammable vapors and liquids.

▲WARNING Do not block flow of air to boiler. Incomplete combustion and flue gas spillage can occur.

▲WARNING Do not store sources of hydrocarbons (i.e., bleaches, cleaners, chemicals, sprays, paint removers, fabric softeners, etc.) in boiler area. This can contribute to shortened boiler/vent system life.

Service and maintenance *(continued)*

▲WARNING The boiler should be inspected and started annually, at the beginning of the heating season, only by a qualified service technician. In addition, the maintenance and care of the boiler designated in Table 12, page 29 and explained on the following pages must be performed to assure maximum boiler efficiency and reliability. Failure to service and maintain the boiler and system could result in equipment failure.

▲WARNING Electrical shock hazard — Turn off power to the boiler before any service operation on the boiler except as noted otherwise in this manual. Failure to turn off electrical power could result in electrical shock, causing severe personal injury or death.

▲WARNING The boiler contains ceramic fiber and fiberglass materials. Use care when handling these materials per instructions on page 28 of this manual. Failure to comply could result in severe personal injury.

Inspect

Reported problems

Inspect any problems reported by owner and correct before proceeding.

Boiler area

1. Verify that boiler area is free of any combustible materials, gasoline and other flammable vapors and liquids.
2. Verify that boiler area is free of any of the contaminants listed on page 7 of this manual. If any of these are present in the boiler intake air vicinity, they must be removed. If they cannot be removed, install combustion air piping to the boiler in accordance with national, provincial or local codes.

Air openings

1. Verify that combustion and ventilation air openings to the boiler room and/or building are open and unobstructed. Check operation and wiring of automatic combustion air dampers, if used.
2. Verify that boiler vent discharge and air intake are clean and free of obstructions.

Flue gas vent system

1. Visually inspect entire flue gas venting system for blockage, deterioration or leakage. Repair any joints that show signs of leakage in accordance with vent manufacturer's instructions.
2. Verify that masonry chimneys are lined, lining is in good condition, and there are not openings into the chimney.

▲WARNING Failure to inspect for the above conditions and have them repaired can result in severe personal injury or death.

Pilot and main burner flames

Visually inspect pilot burner and main burner flames as directed on page 26 of this manual.

Piping

1. Check the boiler interior piping and all system piping for signs of leaks. Repair any leaks before proceeding.

▲DANGER Do not use petroleum-based cleaning or sealing compounds in boiler system. Severe damage to boiler will occur, resulting in substantial property damage.

▲WARNING Eliminate all system or boiler leaks. Continual fresh makeup water will reduce boiler life. Minerals can build up in sections, reducing heat transfer, overheating cast iron, and causing section failure. Leaking water may also cause severe property damage.

Boiler heating surfaces

▲WARNING The boiler contains ceramic fiber and fiberglass materials. Use care when handling these materials per instructions on page 28 of this manual. Failure to comply could result in severe personal injury.

1. Disconnect the vent pipe at the boiler draft diverter and remove draft diverter after turning off power to the boiler.
2. Use a bright light to inspect the boiler flue collector and heating surfaces.
3. If the vent pipe or boiler interior surfaces show evidence of soot, follow “Cleaning boiler heating surfaces”, page 30. Remove the flue collector and clean the boiler if necessary after closer inspection of boiler heating surfaces.
4. If there is evidence of rusty scale deposits on boiler surfaces, check the water piping and control system to make sure the boiler return water temperature is properly maintained (per this manual).
5. Reconnect vent and draft diverter. Replace all boiler components before returning to service.
6. Check inside and around boiler for evidence of any leaks from the boiler. If found, locate source of leaks and repair.

Burners and base

1. After turning off power to the boiler, remove the jacket door and base access panel.
2. Inspect burners and all other components in the boiler base.
3. If burners must be cleaned, raise rear of each burner to release from support slot, slide forward and remove. Then brush and vacuum the burners thoroughly, making sure all ports are free of debris. Carefully replace all burners, making sure burner with pilot bracket is replaced in its original position and all burners are upright (ports up).
4. Inspect the base insulation.
 - a. Verify that the insulation is intact and secure against all four sides of the base.

▲WARNING If insulation is damaged or displaced, do not operate the boiler. Replace or reposition insulation as necessary. Failure to replace damaged insulation can result in a fire hazard, causing severe personal injury, death or substantial property damage.

Service and maintenance *(continued)*

□ Service

Gauge glass (steam boilers)

NOTICE Normal waterline is halfway up gauge glass. Clean when needed.

1. Close lower gauge cock.
2. Open pet cock.
3. Open lower gauge cock and allow a small amount of water to flush out through open pet cock.
4. Close pet cock.
5. Open lower gauge cock.

DANGER Boiler pressure must be low to eliminate potential of severe burns.

WARNING If gauge glass breaks, close both gauge cocks. Replace gauge glass. Do not replace with thin glass tubing. Failure to comply could cause severe personal injury, death or substantial property damage.

□ Start-up

1. Perform “Start-up” procedures in this manual, pages 24–27, including “Verify operation” of burners and vent damper on page 26.
2. Check gas piping, per pages 22 and 24, verifying no indications of leakage and all piping and connections are in good condition.
3. Read the “Lighting Instructions” in the Control Supplement.
4. Start the boiler following the “Lighting Instructions.”

□ Check/test

Gas piping

1. Sniff near floor and around boiler area for any indication of a gas leak.
2. Test gas piping using bubble test, per page 22 of this manual, if there is any indication of a leak.

Boiler waterline

Normal waterline is halfway up gauge glass.

Limit controls

1. Inspect and test the boiler limit control. Verify operation by turning control set point below boiler pressure. Boiler should cycle off. Return dial to original setting.

Probe-type low water cutoff (when used)

WARNING Clean probe-type low water cutoff (when used) for proper operation.

1. Turn off power to boiler and wait 5 minutes.
2. Drain water to bottom of gauge glass.
3. Turn on power.
4. Set thermostat to call for heat. Red neon lamp on lower water cutoff should light.
5. Wait 5 minutes. Boiler should not fire.
6. Refill boiler to correct waterline. Red lamp should go off.
7. Wait 5 minutes. Boiler should fire.
8. Return thermostat to normal setting.

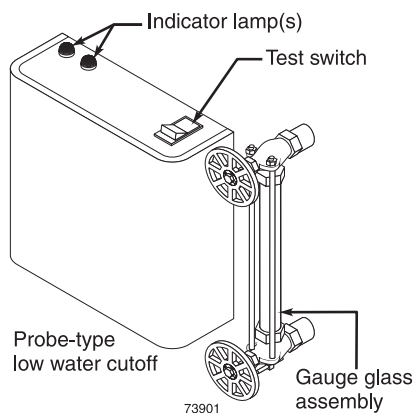

Float-type low water cutoff (when used)

WARNING Clean float-type low water cutoff to clear float chamber of sediment.

1. Open blowdown valve at bottom control.
 2. Drain water into a bucket.
- DANGER** Scald potential. Boiler pressure must be low to avoid the potential of severe burns from steam.
3. Check float-type low water cutoff for proper operation:
 - a. Turn operating control to call for heat.
 - b. Before water gets hot, drain to bottom of gauge glass. Boiler should shut off after water level lowers a few inches.
 - c. Refill boiler to correct waterline. Boiler should come back on.

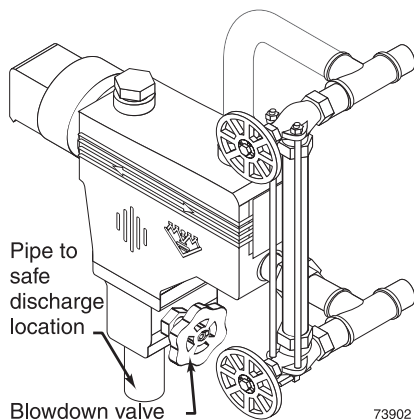

Service and maintenance *(continued)*

☐ Check/test

Boiler relief valve

1. After following the warning directions below, if the relief valve weeps or will not seat properly, replace the relief valve.

⚠ DANGER Before testing, make certain discharge pipe is properly connected to valve outlet and arranged to contain and safely dispose of boiler discharge. Wear gloves to protect your hands from hot surfaces. Verify that discharge piping is installed in accordance with this manual and the instructions on the relief valve tag. Failure to comply will expose operator and others to severe personal injury or death.

⚠ WARNING Safety relief valves should be reinspected AT LEAST ONCE EVERY THREE YEARS, by a licensed plumbing contractor or authorized inspection agency, to ensure that the product has not been affected by corrosive water conditions and to ensure that the valve and discharge line have not been altered or tampered with illegally. Certain naturally occurring conditions may corrode the valve or its components over time, rendering the valve inoperative. Such conditions are not detectable unless the valve and its components are physically removed and inspected. This inspection must only be conducted by a plumbing contractor or authorized inspection agency — not by the owner. Failure to reinspect the boiler relief valve as directed could result in unsafe pressure buildup, which can result in severe personal injury, death or substantial property damage.

⚠ WARNING Check the setting of the boiler limit control. The control should never be set with a pressure above 10 psig. Operating at a higher pressure can cause damage to the boiler relief valve.

⚠ WARNING The boiler relief valve must be tested at least monthly during the heating season to verify the valve and discharge piping flow freely. If corrosion and/or deposits are noticed within the valve body, testing must be performed more often. A “try lever test” must also be performed at the end of any non-service period. Follow the instructions below for a “try lever test”:

With the system at operating pressure, lift and hold the test lever fully open for at least 5 seconds to flush the valve seat free of sediment and debris. Then release lever and permit the valve to snap shut.

☐ Review with owner

1. Review the User’s Information Manual with the owner.
2. Emphasize the need to perform the maintenance schedule specified in the User’s Information Manual (and in this manual as well).
3. Remind the owner of the need to call in a licensed contractor should the boiler or system exhibit any unusual behavior.
4. Remind the owner to follow the proper shutdown procedure and to schedule an annual start-up at the beginning of the next heating season.

☐ Cleaning boiler heating surfaces

⚠ WARNING The boiler contains ceramic fiber and fiberglass materials. Use care when handling these materials per instructions on page 28 of this manual. Failure to comply could result in severe personal injury.

1. Follow shut-down procedure
2. Disconnect breeching and remove damper (if used) and draft hood.
3. Remove upper rear jacket panel. Turn back jacket insulation to expose collector hood.
4. Remove collector hood. Clean excess boiler cement from collector hood and cast iron sections.
5. Remove burners from base of boiler. Follow “Cleaning main burners” to thoroughly clean burners. Place newspaper in base of boiler to collect soot that will fall.
6. With a wire flue brush, clean between the sections.
7. Remove paper and soot. Vacuum or brush base and surrounding area.
8. Replace collector hood. Seal with boiler cement.
9. Replace draft hood, damper (if used) and breeching.
10. Replace insulation and jacket panel.
11. Replace main burners.

Cleaning main burners

1. Vacuum or brush burners to remove dust and lint.

⚠ DANGER When replacing, burner tubes must be seated in slots in the back with openings face up. Gas orifices must inject down center of burner. Failure to properly seat burners will result in severe personal injury, death or substantial property damage.

Annual shut-down procedure

1. Follow correct lighting/operating instructions on boiler.
2. Do not drain system unless exposure to freezing temperatures will occur. If antifreeze is used with system, do not drain.
3. If complete boiler and piping system must be drained to avoid freezing, provide method to drain water from both ends of boiler at or below return tapping level.

Replacement parts — EG/PEG

Table 13 EG/PEG replacement parts

Item	Description	Boiler Models	Part Number
A	Left hand end section with heater opening (Pattern No. 1814)	—	311-800-014
	Left end section without heater opening (Pattern No. 1813)	—	311-800-007
B	Right hand end section without heater opening (Pattern No. 18118)	—	311-800-029
C	Intermediate section (Pattern No. 1815)	—	311-800-010
D	Draft hood	EG-30	450-021-255
		EG-35	450-021-256
		EG-40	450-021-257
		EG-45	450-021-258
		EG-50	450-021-259
		EG-55	450-021-260
		EG-65	450-021-261
E	Collector hood	EG-30, 35	450-014-733
		EG-40, 45	450-014-734
		EG-50, 55	450-014-735
		EG-65	450-014-736
		EG-75	450-014-737
F	Burner, steel tube, regular stainless	—	512-200-000
F₁	Burner, steel tube, with pilot bracket "PI" system (ALL) "SPN" system (EG-75) "SPL" system (ALL)	—	512-200-001
	Burner, steel tube, with slot and pilot bracket "SPN" system (EG-30 & -65 Only)	—	512-200-002
G	Manifold	EG-30	591-125-533
		EG-35	591-125-538
		EG-40	591-125-534
		EG-45	591-125-539
		EG-50	591-125-535
		EG-55	591-125-540
		EG-65	591-125-541
	Main burner orifice, natural gas, 2.45mm (note 1) (not shown)	—	560-528-987
	Main burner orifice, propane gas, 1.55mm (note 1) (not shown)	—	560-528-988
	Section assembly, complete without heater opening (not shown)	EG-30, 35	321-811-095
	Section assembly, complete with heater opening (not shown)	EG-35	321-811-100
	Section assembly, complete with heater opening (not shown)	EG-40, 45	321-811-110
	Section assembly, complete without heater opening (not shown)	EG-40, 45	321-811-115
	Section assembly, complete with heater opening (not shown)	EG-50, 55	321-811-120
	Section assembly, complete without heater opening (not shown)	EG-50, 55	321-811-125
	Section assembly, complete with heater opening (not shown)	EG-65	321-811-130
	Section assembly, complete without heater opening (not shown)	EG-65	321-811-135
	Section assembly, complete with heater opening (not shown)	EG-75	321-811-140
	Section assembly, complete without heater opening (not shown)	EG-75	321-811-145
	Retort cement (1 quart) (not shown)	—	591-602-913
	Flue brush (not shown)	—	591-706-214

Item	Description	Boiler Models	Part Number
H	Front base panel	EG-30, 35	451-800-000
		EG-40, 45	450-800-001
		EG-50, 55	451-800-002
		EG-65	451-800-003
		EG-75	451-800-004
H₁	Base insulation kit (includes front and rear base panel insulation, water glass, and boiler cement)	—	510-811-660
H₂	Base front access panel with flame rollout switch bracket	EG-30, 35	451-800-040
		EG-40, 45	451-800-041
		EG-50	451-800-039
		EG-55	451-800-042
		EG-65	451-800-043
		EG-75	451-800-044
H₃	Back burner support	EG-30	451-800-085
		EG-35	451-800-086
		EG-40	451-800-087
		EG-45	451-800-088
		EG-50	451-800-089
		EG-55	451-800-090
		EG-65	451-800-092
I	Back base panel	EG-30, 35	451-800-010
		EG-40, 45	451-800-011
		EG-50, 55	451-800-012
		EG-65	451-800-013
		EG-75	451-800-014
I₂	Base back channel	EG-30, 35	451-800-020
		EG-40, 45	451-800-021
		EG-50, 55	451-800-022
		EG-65	451-800-023
		EG-75	451-800-024
J	Base side rail (2 required)	—	451-800-070
K	Spill switch	—	510-300-013
L	Cover plate for heater opening (rectangular)	—	389-900-103
L₂	Gasket for cover plate (rectangular)	—	590-317-579
L₃	Cover plate for heater opening (round)	—	389-900-101
L₄	Gasket for cover plate (round)	—	590-317-495
	Section replacement kit (includes 3" and 6" elastomer seal, 2 pieces of rope, tube of silicone; order 1 per joint between sections) (not shown)	—	381-800-667
	3" diameter bottom elastomer seal (1 per joint) (not shown)	—	592-800-010
	6" diameter top elastomer seal (1 per joint) (not shown)	—	592-800-007
	Sealer for sections (2 pieces of rope, tube of silicone per joint) (not shown)	—	591-641-865
	½" Tie rod without nut (2 per boiler) (not shown)	EG-30, 35	560-234-470
	½" Tie rod without nut (2 per boiler) (not shown)	EG-40, 45	560-234-475
	½" Tie rod without nut (2 per boiler) (not shown)	EG-50, 55	560-234-480
	½" Tie rod without nut (2 per boiler) (not shown)	EG-65	560-234-485
	½" Tie rod without nut (2 per boiler) (not shown)	EG-75	560-234-490
	½" Nut (2 per tie rod) (not shown)	—	561-928-221
	½" Lock washer (1 per tie rod) (not shown)	—	562-248-668

Note 1: Order sufficient quantities to replace all orifices within a base.

Replacement parts — EG/PEG *(continued)*

WARNING The boiler contains ceramic fiber and fiberglass materials. Use care when handling these materials per instructions on page 28 of this manual. Failure to comply could result in severe personal injury.

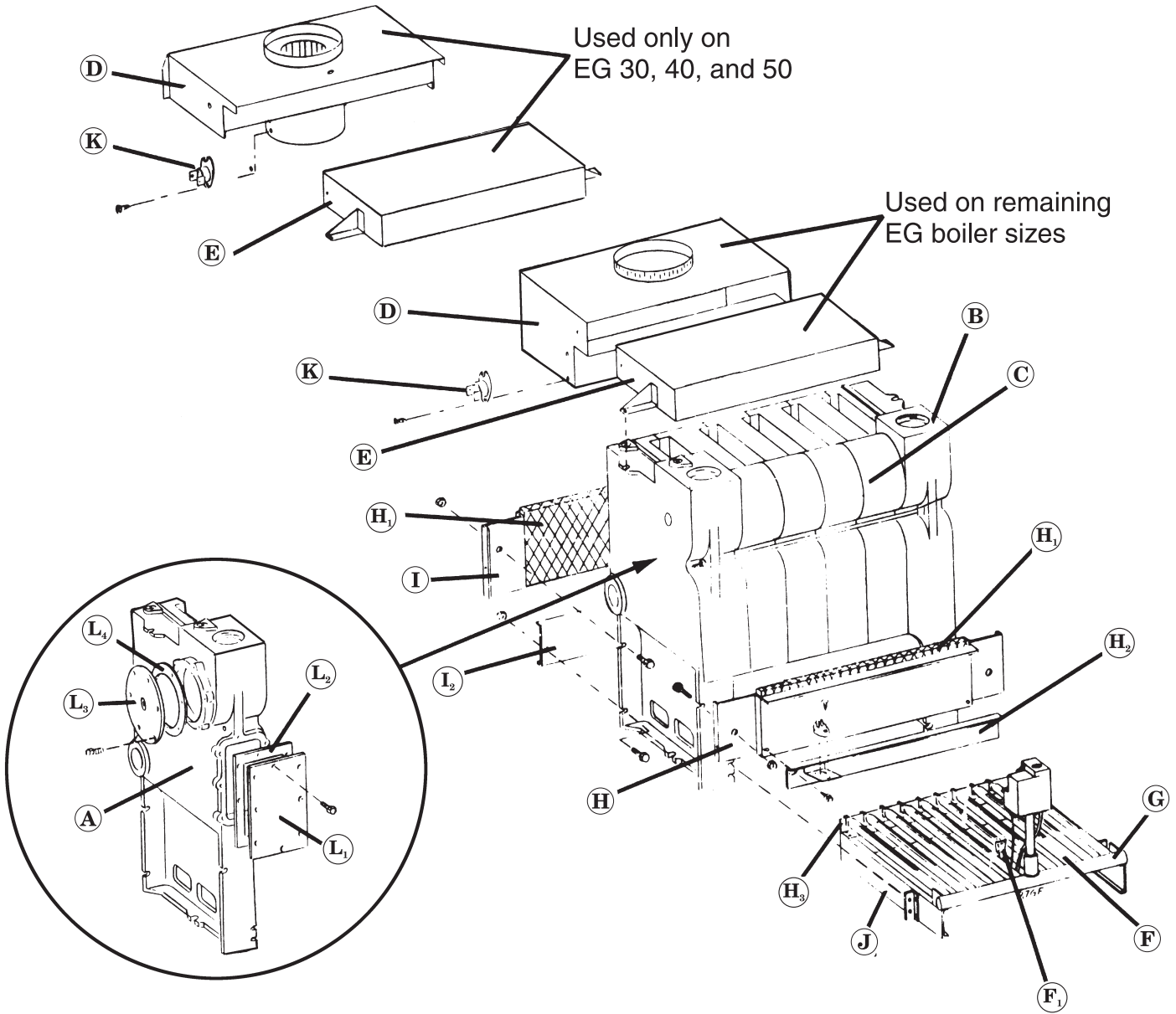

NOTE 1: Order sufficient quantities to replace all orifices within a base

Replacement parts — EGH

Table 14 EGH replacement parts

Item	Description	Boiler Models	Part Number
A	Left hand end section with heater opening (Pattern No. 1814)	—	311-800-014
	Left hand end section without heater opening (Pattern No. 1813)	—	311-800-007
B	Right hand end section with heater opening (Pattern No. 1819)	—	311-800-022
	Right hand end section without heater opening with control tappings (Pattern No. 18118)	—	311-800-032
C	Intermediate section (Pattern No. 1815)	—	311-800-010
	Intermediate section with tie rod lugs (Pattern No. 1817)	—	311-800-026
C ₁	3" Diameter bottom elastomer seal (1 per joint)	—	592-800-010
	6" Diameter top elastomer seal (1 per joint)	—	592-800-007
D	Draft hood	EGH-85	450-206-240
		EGH-95	450-206-241
		EGH-105	450-206-242
		EGH-115	450-206-243
		EGH-125	450-206-244
E	Collector hood	EGH-85	450-014-750
		EGH-95	450-014-751
		EGH-105	450-014-752
		EGH-115	450-014-753
		EGH-125	450-014-754
F	Burner, stainless tube, regular	—	512-200-000
F ₁	Burner, stainless tube, with pilot bracket	—	512-200-001
G	Manifold	EGH-85	591-125-543
		EGH-95	591-125-544
		EGH-105	591-125-545
		EGH-115	591-125-546
		EGH-125	591-125-547
	Main burner orifice, natural gas, 2.45mm (note 1)	—	560-528-987
	Main burner orifice, propane gas, 1.55mm (note 1)	—	560-528-988
H	Front base panel (in base panel carton)	—	—
H ₁	Front base insulation (in base panel carton)	—	—
H ₂	Base front access panel (in base panel carton)	—	—
H, H ₁ , H ₂ , I, I ₁ & I ₂	Base panel carton	EGH-85	381-700-240
		EGH-95	381-700-245
		EGH-105	381-700-250
		EGH-115	381-700-255
		EGH-125	381-700-260
I	Back base panel (in base panel carton)	—	—
I ₁	Back base insulation (in base panel carton)	—	—
I ₂	Back base channel (in base panel carton)	—	—
J	Side rail for burner panel with bracket for burner pan	—	451-800-070

Item	Description	Boiler Models	Part Number
J ₁	Back burner support	EGH-85	451-800-095
		EGH-95	451-800-096
		EGH-105	451-800-097
		EGH-115	451-800-098
		EGH-125	451-800-099
L ₁	Cover plate for heater opening (rectangular)	—	389-900-103
L ₂	Gasket for cover plate (rectangular)	—	590-317-579
L ₃	Cover plate for heater opening (round)	—	389-900-101
L ₄	Gasket for cover plate (round)	—	590-317-495
	Section assembly, complete with heater opening (not shown)	EGH-85	321-711-100
	Section assembly, complete without heater opening (not shown)	EGH-85	321-711-105
	Section assembly, complete with heater opening (not shown)	EGH-95	321-711-110
	Section assembly, complete without heater opening (not shown)	EGH-95	321-711-115
	Section assembly, complete with heater opening (not shown)	EGH-105	321-711-120
	Section assembly, complete without heater opening (not shown)	EGH-105	321-711-125
	Section assembly, complete with heater opening (not shown)	EGH-115	321-711-130
	Section assembly, complete without heater opening (not shown)	EGH-115	321-711-135
	Section assembly, complete with heater opening (not shown)	EGH-125	321-711-140
	Section assembly, complete without heater opening (not shown)	EGH-125	321-711-145
	Section replacement kit (includes 3" and 6" elastomer seal, 2 pieces of rope, tube of silicone, order 1 per joint between sections) (not shown)	—	381-800-667
	Burner shields (rollout)	EGH-85	451-800-120
		EGH-95	451-800-121
		EGH-105	451-800-122
EGH-115		451-800-123	
EGH-125		451-800-124	
	Sealer for sections (2 pieces of rope, tube of silicone per joint between sections) (not shown)	—	591-641-865
	½" x 7" Tie rod w/o nut (2 per boiler) (not shown)	—	560-234-465
	½" x 17" Tie rod w/o nut (not shown)	(4 - EGH-85) (2 - EGH-95)	560-234-472
	½" x 21¼" Tie rod w/o nut (not shown)	(2 - EGH-95) (2 - EGH-115) (4 - EGH-125)	560-234-477
	½" x 25¼" Tie rod w/o nut (not shown)	(2 - EGH-115) (4 - EGH-125)	560-234-482
	½" Nut (2 per tie rod)	—	561-928-221
	½" Lock washer (1 per tie rod)	—	562-248-668
	Retort cement (1 quart)	—	591-602-913
	Flue brush (not shown)	—	591-706-214

Note 1: Order sufficient quantities to replace all orifices within a base.

Replacement parts — EGH *(continued)*

⚠ WARNING The boiler contains ceramic fiber and fiberglass materials. Use care when handling these materials per instructions on page 28 of this manual. Failure to comply could result in severe personal injury.

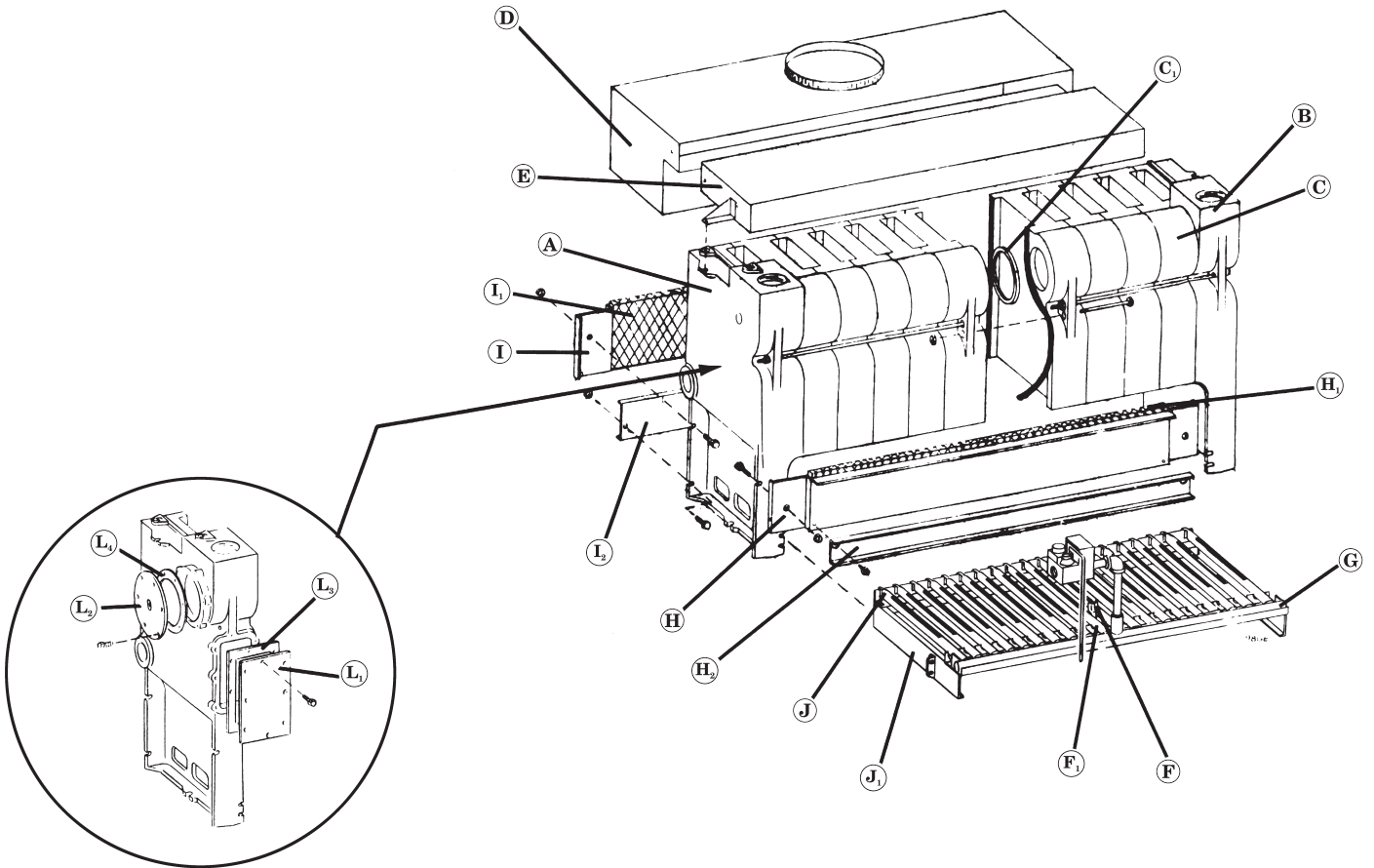

Dimensional data

Table 15 Dimensional data

Boiler number	Supply EG/EGH	Return EG/EGH	Dimensions (See note 3 for PEG-30 to PEG-55 crate dimensions)						Gas connection "F" (note 1)	Draft hood outlet size	Approx. ship. wt. (lbs.)
			W	A	B	B1	V (note 2)	T			
EG & PEG-30 & -35	1 - 3"	1 - 2 1/2"	17"	5"	11 3/4"	6 3/4"	6"	Water boiler tankless coil removal clearance: E-624: 14" E-626: 18" E-632: 22"	1/2"	5"	430
EG & PEG-40 & -45	1 - 3"	1 - 2 1/2"	21 1/4"	6"	11 3/4"	6 3/4"	6 1/2"		1/2"	6"	505
EG & PEG-50 & -55	1 - 3"	1 - 2 1/2"	25 1/2"	7"	11 3/4"	6 3/4"	9"		1/2"	7"	585
EG & PEG-65	1 - 3"	1 - 2 1/2"	29 3/4"	8"	11 3/4"	6 3/4"	9 1/2"		3/4"	8"	660
EG-75	1 - 3"	1 - 2 1/2"	34"	8"	15 3/4"	8 3/4"	—		3/4"	8"	735
EGH-85	2 - 3"	2 - 2 1/2"	38 1/4"	9"	15 3/4"	8 3/4"	—		3/4"	9"	825
EGH-95	2 - 3"	2 - 2 1/2"	42 1/2"	10"	15 3/4"	8 3/4"	—		3/4"	10"	915
EGH-105	2 - 3"	2 - 2 1/2"	46 3/4"	10"	15 3/4"	8 3/4"	—		1"	10"	1005
EGH-115	2 - 3"	2 - 2 1/2"	51"	12"	15 3/4"	8 3/4"	—		1"	12"	1095
EGH-125	2 - 3"	2 - 2 1/2"	55 1/4"	12"	15 3/4"	8 3/4"	—		1"	12"	1185

Notes:
 1. Sizes shown are gas connection sizes, natural or propane gas. Gas piping from meter to boiler to be sized according to local utility requirements. Gas line can enter through either the right or left end of the boiler.
 2. Damper dimension for EG-30 through EG-65 ONLY. For EG-75 and all EGH the damper is additional equipment.
 3. PEG crates are 32" wide by 39" high. Crate lengths are: 32" for PEG-30, -35, -40; 37" for PEG-45, -50, -55; 39" for PEG-65.

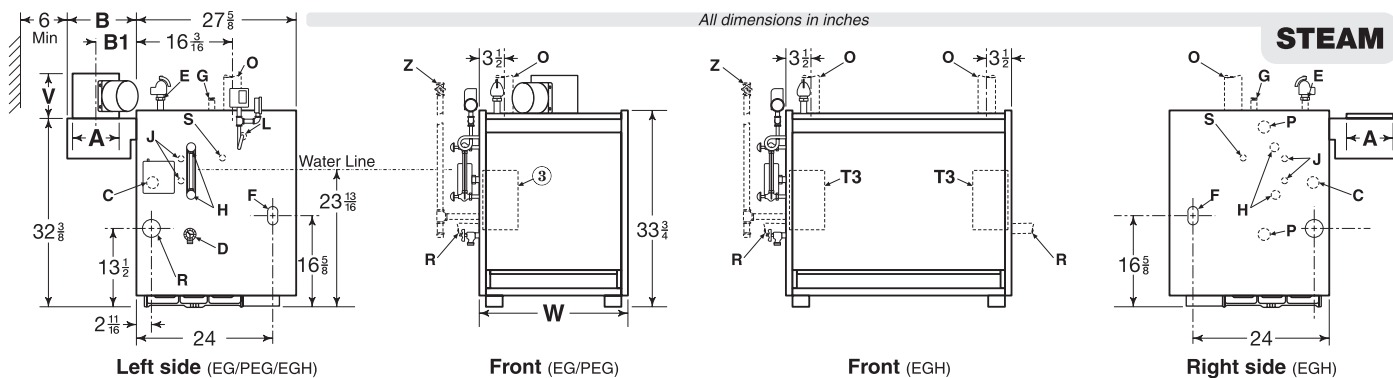
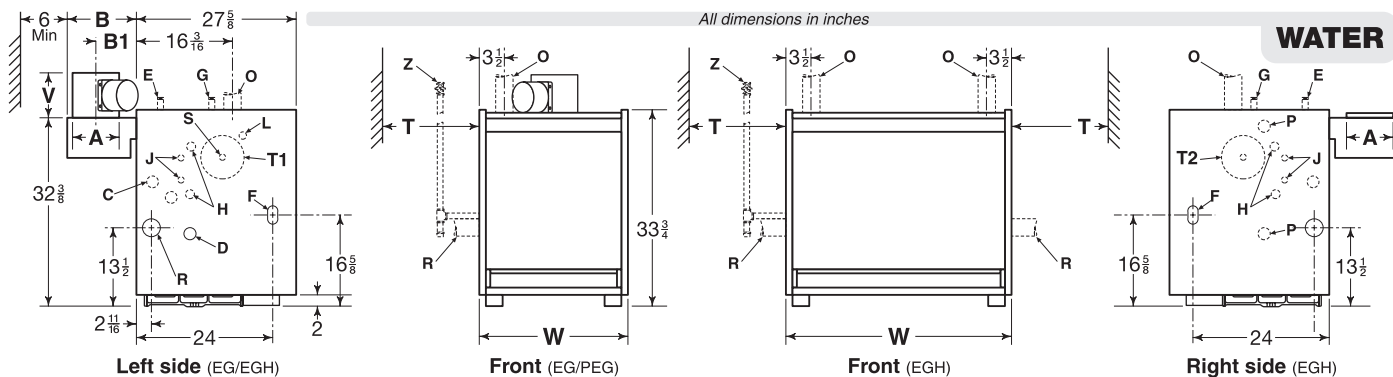

Tapping	Size	Steam Boilers	Water Boilers	Tapping	Size	Steam Boilers	Water Boilers
C	3/4	Probe type low water cut-off	Probe type BWCO (when used)	P (EGH Only)	1	Float type BWCO, pressure limit control and pressure gauge; or BWCO and feeder combination; or BWCO and pump control	Float type BWCO; or BWCO and feeder combination; or BWCO and pump control
D	3/4	Drain	Drain	S	1 1/2	Skim tapping	Limit control
E	3/4	Safety valve	Safety relief valve		3/4	— (note 1)	Limit control
G	3/4	Plugged	Piping to compression tank or auto air vent	T1	—	—	Optional tankless heater for water boilers
H	1/2	Gauge glass and/or optional BWCO	Combination pressure temperature gauge	T2	—	—	Optional tankless heater for EGH water boilers only
J	3/8	Tri cock tappings	Plugged	T3	—	Optional steam boiler tankless heater	—
L	1/2	Syphon, pressure gauge, high limit (Probe type BWCO)	Combination pressure temperature gauge	Z	—	Manual shut-off gas valve (supplied by installer)	—
Notes	1. Available on special request only when tankless heater is specified. 2. Limit control and supply piping must be on the same end of the EGH boiler			Notes	3. When a tankless water heater coil is installed, use the tapping in the heater for an additional operating		

Ratings

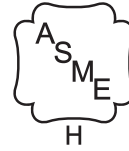

Boiler Model Number	0–2,000 feet altitude		2,000–4,500 feet altitude (Canada)		Net AHRI Ratings			Chimney Size	Boiler Water Content (Gallons)	
	Input (Btuh)	DOE Heating Capacity (Output) (Btuh)	Input (Btuh)	(Output) (Btuh)	Sq. Ft. Steam	Steam Btuh	Water Btuh		Water	Steam (to Waterline)
(Note 1 & 2)		(Note 3)	(Note 4)		(Note 5)					
*EG-30-	75,000	62,000	67,500	56,000	196	47,000	55,000	5" I.D. x 20'	12.3	8.4
*EG-35-	100,000	83,000	90,000	75,000	258	62,000	73,000	5" I.D. x 20'	12.3	8.4
*EG-40-	125,000	104,000	112,500	93,000	325	78,000	91,000	6" I.D. x 20'	14.8	9.8
*EG-45-	150,000	125,000	135,000	112,000	392	94,000	110,000	6" I.D. x 20'	14.8	9.8
*EG-50-	175,000	145,000	157,500	131,000	454	109,000	128,000	7" I.D. x 20'	17.3	11.2
*EG-55-	200,000	167,000	180,000	150,000	521	125,000	146,000	7" I.D. x 20'	17.3	11.2
*EG-65-	250,000	209,000	225,000	188,000	654	157,000	183,000	8" I.D. x 20'	19.8	12.6
*EG-75-	299,000	247,000	270,000	216,000	770	185,000	217,000	8" I.D. x 20'	22.3	14.0
EGH-85-	349,000	280,000	315,000	252,000	875	210,000	243,000	9" I.D. x 20'	24.8	15.4
EGH-95-	400,000	320,000	360,000	288,000	1,000	240,000	278,000	10" I.D. x 20'	27.3	16.8
EGH-105-	450,000	360,000	-	-	1,125	270,000	313,000	10" I.D. x 20'	29.8	18.2
EGH-115-	500,000	400,000	-	-	1,250	300,000	348,000	12" I.D. x 20'	32.3	19.6
EGH-125-	550,000	440,000	-	-	1,375	330,000	383,000	12" I.D. x 20'	34.8	21.0

Notes (Table 16)

- * Add prefix "P" for package boiler completely assembled and wired with jacket and controls (PEG-30-S through PEG-65-S only).
- 1. **EG-30 thru 75:** Add suffix "SPD" or "SP" for standing pilot; add "PID" or "PI" for electronic ignition (30-65 — damper required in U.S.; optional in Canada); add "N" for natural; add "L" for propane; add "W" for water; add "S" for steam; add "T" for tankless heater; add "P" for provisional tankless heater.
EGH-85 & 95: Add suffix "SP" for standing pilot; add "PI" for electronic ignition (damper available on PI only); add "N" for natural; add "L" for propane; add "W" for water; add "S" for steam; add "T" for tankless heater (tankless available on EGH-85 thru 125 PI Water and Steam; EGH-85 and 95 SP Steam only); add "P" for provisional tankless heater.
EGH-105 thru 125: Add suffix "PI" for electronic ignition (damper available on PI only); add "W" for water; add "S" for steam; add "T" for tankless heater.
- 2. EGH water boilers tested for 50 P.S.I working pressure.
- 3. Based on standard test procedures prescribed by the United States Department of Energy.
EG-75 thru EGH-125: CSA Gross output.
- 4. EGH-105 thru 125 may be installed at altitudes of 2,000-4,500 feet subject to acceptance by Provincial Inspections Authority based on field tests of individual installations.
- 5. Net AHRI ratings are based on net installed radiation of sufficient quantity for the requirements of the building and nothing need be added for normal piping and pick-up. Water ratings are based on a piping and pick-up allowance of 1.15; steam ratings on an allowance of 1.333. An additional allowance should be made for unusual piping and pick-up loads. Consult local Weil-McLain representative.

Table 17 DOE seasonal efficiencies

Boiler Model Number	DOE season efficiency (AFUE)					
	Water			Steam		
	SPDN	SPDL	PIDN	SPDN	SPDL	PIDN
EG-30 PEG-30	82.2	84.2	84.3	81.0	82.9	83.0
EG-35 PEG-35	82.0	83.7	83.6	81.3	82.5	82.9
EG-40 PEG-40	82.5	84.3	84.0	81.5	83.2	82.9
EG-45 PEG-45	82.4	84.0	83.5	81.6	83.0	82.9
EG-50 PEG-50	82.9	84.4	83.8	81.9	83.7	82.8
EG-55 PEG-55	82.5	84.2	83.8	81.9	83.5	82.8
EG-65 PEG-65	82.6	84.0	84.0	82.0	82.8	83.0
EG-75	—	—	82.7	—	—	82.4

Standard and optional equipment

Standard equipment

- Factory-Assembled Section Block
- Insulated Extended Jacket
- Draft Hood
- Aluminized Steel Burners
- Non-Linting Pilot Burner
- Heater Cover Plates (for boilers with tankless heater openings)
- Control Wire
- Electrical Junction Box

EG/PEG boilers add:

- Combination Gas Valve for 24 volt
- Thermocouple (high efficiency models)
- Rollout Thermal Fuse Element
- Spill Switch
- Highest Efficiency Models, PID Intermittent Electronic Ignition System and Automatic Vent Damper
- High Efficiency Models, SPD Constant Burning, Thermally Supervised Pilot System and Automatic Vent Damper

For EG water boilers

- Built-In Air Eliminator
- 30 P.S.I. Relief Valve
- Combination Pressure Temperature Gauge
- High-Limit Control
- 40 VA Transformer with Receptacle for Circulator Relay
- Circulator Relay

For EG/PEG steam boilers

- Relief Valve
- Steam Pressure Gauge
- High-Limit Pressure Control
- Syphon
- Gauge Cocks
- Gauge Glass
- Low-Water Cutoff
- 40 VA Transformer

EG additional equipment

- Tankless Water Heater (EG-35 – 65 PI and SP; EG-75 PI only)
With tankless heater: Combination High Limit, Low Limit, Circulator Control, and Relay with 40 VA Transformer
- Tankless Steam Heater (EG-35 – 75)
With Tankless Heater: Operating Control and Tankless Heater 35-S-29 for All Units

EGH boilers add:

- Combination Gas Control Valve (includes main gas valve with redundant seat, PI and PI with damper models; main gas valve with single seat, 24V models; pressure regulator, gas cock, pilot filter, pilot adjustment)
- Highest Efficiency Models, PI Intermittent Electronic Ignition System
- High Efficiency Models, SP Constant Burning, Thermally Supervised Pilot System, Thermocouple
- 100% Shutoff
- 40 VA Transformer with Receptacle for Circulator Relay

For EGH water boilers

- Built-in Air Eliminator
- 30 P.S.I. Relief Valve
- Combination Pressure-Temperature Gauge
- High-Limit Control for PI and PI with Damper Models
- Dual-Limit Control for Standard Efficiency Models
- Circulator Relay

For EGH steam boilers

- Relief Valve
- Steam Pressure Gauge
- High-Limit Pressure Control (two limit controls on EGH-85 and 95 SP)
- Syphon
- Gauge Cocks
- Gauge Glass
- Low-Water Cutoff – Probe Type

EGH additional equipment

- Tankless Heaters – PI Water or Steam, SP Steam only
- With Tankless Heater(s):
 - Operating Control
 - Automatic Vent Damper



Weil-McLain
500 Blaine Street
Michigan City, IN 46360-2388
<http://www.weil-mclain.com>