

# TEMPSTAR®

## Heating and Cooling Products

# RHX

## Product Specifications

### PACKAGE HEAT PUMP UNIT R-410A SINGLE PACKAGE ROOFTOP 3 – 5 TONS (1 & 3-Phase)

#### BUILT TO LAST, EASY TO INSTALL AND SERVICE

- Meets or exceeds ASHRAE 90.1 energy compliant efficiency levels
- SEERs up to 14.3, EERs up to 12.2
- HSPF's up to 8.2
- Single stage cooling capacity control
- Exclusive non-corrosive composite condensate pan in accordance with ASHRAE 62 Standard, sloping design; side or center drain
- Convertible from vertical to horizontal airflow for slab mounting
- Copper tube aluminum fin coils with optional corrosion resistant coils
- Pre-painted exterior panels and tested to 500 hours salt spray protection
- Fixed orifice refrigerant metering system
- Cooling operating range up to 115F (46C) and down to 25F (-4C)
- Solid-state control board and easy access terminal board
- Refrigerant filter drier and accumulator on each refrigerant circuit
- Automatic changeover when used with auto-changeover thermostat
- Rated in accordance with AHRI Standards 210/240 (036-060)
- Designed in accordance with Underwriters' Laboratories Std 1995
- Listed by UL and UL, Canada



Use of the AHRI Certified TM Mark indicates a manufacturer's participation in the program. For verification of certification for individual products, go to [www.ahridirectory.org](http://www.ahridirectory.org).



#### MAINTENANCE FEATURES

- Access panels with easy grip handles
- Innovative, easy starting, no strip screw features on unit access panels.
- Two-inch disposable return air filters with tool-less filter access door
- Belt drive evaporator-fan motor and pulley combinations available on all sizes to meet any application
- Direct Drive ECM - indoor motor is standard with optional belt drive systems
- New terminal board facilitating simple safety circuit troubleshooting and simplified control box arrangement

#### INSTALLATION FEATURES

- Thru-the-bottom power entry capability standard
- Single point electric connections
- Full perimeter base rail with built-in rigging adapters & fork truck slots

#### RELIABILITY FEATURES

- Scroll compressors with internal line break overload protection
- Dependable Time / Temperature defrost board and logic
- 24-volt control circuit protected with resettable circuit breaker
- Permanently lubricated evaporator-fan motor
- Totally enclosed condenser motors with permanently lubricated bearings
- Loss of charge, freeze protection, and high-pressure switches

#### FACTORY OPTIONS INCLUDING BUT NOT LIMITED TO:

- 115-volt convenience outlet (Non-powered)
- Non-fused disconnect switch
- Supply air smoke detector
- Economizer with db, enthalpy or CO2 control options
- Corrosion resistant coil options for evaporator and condenser
- Multiple indoor fan motors for expanded airflow capability(3ph)
- Accessory electric heat (field-installed option only)
- Integrated economizer system. Standard and Ultra Low leak versions available.

#### LIMITED WARRANTY \*

- 5 year compressor limited warranty
- 1 year parts limited warranty

\* See warranty certificate for complete details and restrictions

UNIT PERFORMANCE DATA									
BASE MODEL	Nominal Tons	COOLING			HEATING			Unit Dimensions H x W x L	Unit Weight lbs (kg)
		Net Cap. (Btuh)	SEER	EER	High Cap. (Btuh)	HSPF	COP		
RHX036*0XA0AAA	3	35,600	14.00	12.10	35,600	8.10	N/A	33-3/8 x 46-3/4 x 74-3/8 (847 x 1187 x 1888)	495 (224)
RHX048*0XA0AAA	4	49,000	14.00	12.10	45,500	8.00	N/A	41-3/8 x 46-3/4 x 74-3/8 (1051 x 1187 x 1888)	580 (263)
RHX060*0XA0AAA	5	58,000	14.30	12.20	58,000	8.20	N/A	41-3/8 x 46-3/4 x 74-3/8 (1051 x 1187 x 1888)	610 (276)

\* Indicates Unit voltage: K = 208/230-1-60, H = 208/230-3-60, L = 460-3-60, S = 575-3-60

# MODEL NUMBER NOMENCLATURE

MODEL SERIES	R	H	X	0	6	0	L	O	A	B	0	A	A	A
Position Number	1	2	3	4	5	6	7	8	9	10	11	12	13	14
R = Rooftop														
H = Heat Pump	Type													
X = ASHRAE 62 Standard	Efficiency													
036 = 3 Tons 048 = 4 Tons 060 = 5 Tons	Nominal Cooling Capacity													
K = 208/230-1-60 H = 208/230-3-60 L = 460-3-60 S = 575-3-60	Voltage													
O = No Heat	Heating Capacity													
X = Standard Motor Direct Drive B = High Static Motor / Drive – Belt Drive C = Medium Static Motor / Drive – Belt Drive H = High Static Motor / Drive – Belt Drive with Hot Gas ReHeat	Motor Option (Indoor Fan)													
A = None B = Economizer w/Bara-relief, OA Temp sensor E = Economizer w/Bara-relief + CO2 Sensor, OA Temp sensor H = Economizer w/Bara-relief, enthalpy sensor L = Economizer w/Bara-relief + CO2 Sensor, enthalpy sensor U = Temp Ultra Low Leak Economizer w/Bara-relief W = Enthalpy Ultra Low Leak Economizer w/Bara-relief P = 2-Position damper	Outdoor Air Options / Control <sup>1</sup>													
0A = No Options AT = Non-powered 115v C.O. 4B = Non-Fused Disconnect BR = Supply Air Smoke Detector AA = Easy Access Hinged Panels	Factory Installed Options													
A = Aluminum / Copper Cond & Evap Coil B = Precoat Alum/Copper Cond with Alum / Copper Evap (3 phase only) C = E-Coated Alum/Copper Cond with Alum / Copper Evap (3 phase only) D = E-Coated Alum / Copper Cond & Evap (3 phase only) E = Copper/Copper Cond & Alum/Copper Evap (3 phase only) F = Copper/Copper Cond & Evap (3 phase only)	Condenser / Evaporator Coil Configuration													
A = Economizer controls for EconoMiZerIV B = Economizer controls for EconoMiZerX	Motor Type Option													

**NOTE:** Factory installed options are NOT available on single phase models. This includes economizers and 2 position dampers.

<sup>1</sup> A combinations of FIOPS are available.

# FACTORY OPTIONS AND/OR ACCESSORIES

**Table 1 – FACTORY-INSTALLED OPTIONS AND FIELD-INSTALLED ACCESSORIES**

CATEGORY	ITEM	FACTORY INSTALLED OPTION	FIELD INSTALLED ACCESSORY
Cabinet	Thru-the-base electrical connections		X
	Hinged Access Panels	X	
Coil Options	Cu/Cu indoor and/or outdoor coils <sup>5</sup>	X	
	Pre-coated outdoor coils <sup>5</sup>	X	
	Premium, E-coated outdoor coils <sup>5</sup>	X	
Condenser Protection	Condenser coil hail guard (louvered design) <sup>5</sup>	X	X
Controls	Thermostats, temperature sensors, and subbases		X
	Smoke detector (supply and/or return air)	X	
	Time Guard II compressor delay control circuit		X
	Phase Monitor		X
Economizers & Outdoor Air Dampers	EconoMi\$er IV (for electro-mechanical controlled – Non FDD (Standard air leak damper models) <sup>5, 6</sup>	X	X
	Motorized 2 position outdoor-air damper <sup>5</sup>	X	X
	Manual outdoor-air damper (25% and 50%)		X
	Barometric relief <sup>1</sup>	X	X
	Power exhaust		X
Economizer Sensors & IAQ Devices	EconoMi\$er X for electro-mechanical controls, complies with FDD (Standard and Ultra Low Leak air damper models) <sup>5, 6</sup>	X	X
	Single dry bulb temperature sensors <sup>2</sup>	X	X
	Differential dry bulb temperature sensors <sup>2</sup>		X
	Single enthalpy sensors <sup>2</sup>	X	X
	Differential enthalpy sensors <sup>2</sup>		X
Electric Heat	CO <sub>2</sub> sensor (wall, duct, or unit mounted) <sup>2</sup>	X	X
	Electric Resistance Heaters		X
Indoor Motor & Drive	Single Point Kit		X
	Multiple motor and drive packages	X	
Low Ambient Control	Winter start kit <sup>3</sup>		X
	Motormaster head pressure controller <sup>3</sup>		X
Power Options	Convenience outlet (unpowered)	X	
	Non-fused disconnect <sup>4</sup>	X	
Roof Curbs	Roof curb 14-in (356mm)		X
	Roof curb 24-in (610mm)		X

**NOTES:**

1. Included with economizer.
2. Sensors for optimizing economizer.
3. See application data for assistance.
4. Available on units with MOCP's of 80 amps or less.
5. Not available as factory installed option on single phase (208/230/1/60) models. Use field-installed accessory where available.
6. FDD –(Fault Detection and Diagnostic) capability per California Title 24 section 120.2

## FACTORY OPTIONS AND/OR ACCESSORIES (cont.)

### **Economizer (dry bulb or enthalpy)**

Economizers save money. They bring in fresh, outside air for ventilation; and provide cool, outside air to cool your building. This is the preferred method of low ambient cooling. When coupled to CO<sub>2</sub> sensors, Economizers can provide even more savings by coupling the ventilation air to only that amount required.

Economizers are available, installed and tested by the factory, with either enthalpy or dry bulb temperature inputs. There are also models for electromechanical as well as direct digital controllers. Additional sensors are available as accessories to optimize the economizers.

Economizers include gravity controlled, barometric relief which equalizes building pressure and ambient air pressures. This can be a cost effective solution to prevent building pressurization.

### **CO<sub>2</sub> Sensor**

Improves productivity and saves money by working with the economizer to intake only the correct amount of outside air for ventilation. As occupants fill your building, the CO<sub>2</sub> sensor detects their presence through increasing CO<sub>2</sub> levels, and opens the economizer appropriately.

When the occupants leave, the CO<sub>2</sub> levels decrease, and the sensor appropriately closes the economizer. This intelligent control of the ventilation air, called Demand Control Ventilation (DCV) reduces the overall load on the rooftop, saving money.

### **Smoke Detectors**

Trust the experts. Smoke detectors make your application safer and your job easier. ICP smoke detectors immediately shut down the rooftop unit when smoke is detected. They are available, installed by the factory, for supply air, return air, or both.

### **Louvered Hail Guards**

Sleek, louvered panels protect the condenser coil from hail damage, foreign objects, and incidental contact.

### **Convenience Outlet (un-powered)**

Lower service bills by including a convenience outlet in your specification. ICP will install this service feature at our factory, powered. Provides a convenient, 15 amp, 115V GFCI receptacle.

### **Non-fused Disconnect**

This OSHA-compliant, factory-installed, safety switch allows a service technician to locally secure power to the rooftop.

### **Power Exhaust Pressure Relief**

Superior internal building pressure control. This field-installed accessory may eliminate the need for costly, external pressure control fans.

### **Time Guard II Control Circuit**

This accessory protects your compressor by preventing short-cycling in the event of some other failure, prevents the compressor from restarting for 30 seconds after stopping.

### **Filter or Fan Status Switches**

Use these differential pressure switches to detect a filter clog or indoor fan motor failure. When used in conjunction with a compatible unit controller/thermostat, the switches will activate an alarm to warn the appropriate personnel.

### **Motorized 2-Position Damper**

The ICP 2-position, motorized outdoor air damper admits up to 100% outside air. Using reliable, gear-driven technology, the 2-position damper opens to allow ventilation air and closes when the rooftop stops, stopping unwanted infiltration.

### **Manual OA Damper**

Manual outdoor air dampers are an economical way to bring in ventilation air. The dampers are available in 25% and 50% versions.

### **Motormaster Head Pressure Controller**

The Motormaster motor controller is a low ambient, head pressure controller kit that is designed to maintain the unit's condenser head pressure during periods of low ambient cooling operation. This device should be used as an alternative to economizer free cooling not when economizer usage is either not appropriate or desired. The Motormaster will either cycle the outdoor fan motors or operate them at reduced speed to maintain the unit operation, depending on the model.

### **Alternate Motors and Drives**

Some applications need larger horsepower motors, some need more airflow, and some need both. Regardless of the case, your ICP expert has a factory installed combination to meet your application. A wide selection of motors and pulleys (drives) are available, factory installed, to handle nearly any application.

### **Thru-the-Base Connections**

Thru-the-base connections, available as either an accessory or as a factory option, are necessary to ensure proper connection and seal when routing wire and piping through the rooftop's basepan and curb. These couplings eliminate roof penetration and should be considered for gas lines, main power lines, as well as control power.

### **Electric Heaters**

ICP offers a full line of field-installed accessory heaters. The heaters are very easy to use and install. All are pre-engineered and certified.

**Table 2 – AHRI COOLING RATING TABLES**

Cooling Mode						
RHX	COOLING STAGES	Nominal Capacity (tons)	Net Cooling Capacity (btuH)	Total Power (kw)	SEER	EER
36	1	3	35,600	2.9	14.00	12.10
48	1	4	49,000	4.0	14.00	12.10
60	1	5	58,000	4.7	14.30	12.20

Heating Mode			
RHX	HSPF	Heating, Low AT 17°F (-8°C) AMBIENT	Heating, High AT 47°F (8°C) AMBIENT
		Capacity (btuh)	Capacity (btuh)
36	8.10	18,400	35,600
48	8.00	23,800	45,500
60	8.20	28,600	58,000

**LEGEND**

- AHRI – Air Conditioning, Heating and Refrigeration Institute
- ASHRAE – American Society of Heating, Refrigerating and Air Conditioning, Inc.
- EER – Energy Efficiency Ratio
- HSPF – Heating Seasonal Performance Factor
- SEER – Seasonal Energy Efficiency Ratio

**NOTES:**

1. Rated and certified under AHRI Standard 210/240.
2. Ratings are based on:  
**Cooling Standard:** 80°F (27°C) db, 67°F (19°C) wb indoor air temp and 95°F db outdoor air temp.
3. All RHX units comply with ASHRAE 90.1 Energy Standard for minimum SEER and EER requirements.



Use of the AHRI Certified TM Mark indicates a manufacturer's participation in the program. For verification of certification for individual products, go to [www.ahridirectory.org](http://www.ahridirectory.org).

**Table 3 – MINIMUM – MAXIMUM AIRFLOWS ELECTRIC HEAT**

Unit RHX	Cooling		Electric Heaters	
	Minimum	Maximum	Minimum	Maximum
36	900	1500	900	1500
48	1200	2000	1200	2000
60	1500	2500	1500	2500

**Table 4 – SOUND PERFORMANCE TABLE**

RHX	Outdoor Sound (dB)								
	A-Weighted	63	125	250	500	1000	2000	4000	8000
36	77	78.9	81.7	74.9	72.5	70.3	65.6	65.6	62.6
48	80	90.4	84.6	77.6	77.5	74.8	70.6	68.0	64.2
60	80	92.7	84.9	79.0	76.7	73.8	69.6	66.4	62.8

**LEGEND**

dB – Decibel

**NOTES:**

1. Outdoor sound data is measured in accordance with AHRI standard 270.
2. Measurements are expressed in terms of sound power. Do not compare these values to sound pressure values because sound pressure accounts for specific environmental factors which do not match individual applications. Sound power values are independent of the environment and therefore more accurate.
3. A-weighted sound ratings filter out very high and very low frequencies, to better approximate the response of an "average" human ear. A-weighted measurements for ICP units are taken in accordance with 270.

**Table 5 – PHYSICAL DATA**

**(COOLING)**

**3 – 5 TONS**

		RHX036	RHX048	RHX060	
Refrigeration System	# Circuits / # Comp. / Type	1 / 1 / Scroll	1 / 1 / Scroll	1 / 1 / Scroll	
	R-410A refrig. charge (lbs-oz)	14.8	18.0	19.8	
	Metering Device	Acutrol	Acutrol	Acutrol	
	High-press. Trip / Reset (psig)	630 / 505	630 / 505	630 / 505	
	Low-press. Trip / Reset (psig)	27 / 44	27 / 44	27 / 44	
Evap. Coil	Material (Tube/Fin)	Cu / Al	Cu / Al	Cu / Al	
	Coil type	3/8-in RTPF	3/8-in RTPF	3/8-in RTPF	
	Rows / FPI	3 / 15	3 / 15	4 / 15	
	Total Face Area (ft <sup>2</sup> )	5.5	5.5	7.3	
	Condensate Drain Conn. Size	3/4-in	3/4-in	3/4-in	
Evap. Fan and Motor	<b>Standard Static 1 phase</b>	Motor Qty / Drive Type	1/ Direct	1/ Direct	1/ Direct
		Max BHP	1	1	1
		RPM Range	600-1200	600-1200	600-1200
		Motor Frame Size	48	48	48
		Fan Qty / Type	1 / Centrifugal	1 / Centrifugal	1 / Centrifugal
	Fan Diameter (in)	10 x 10	10 x 10	10 x 10	
	<b>Standard Static 3 phase</b>	Motor Qty / Drive Type	1/ Direct	1/ Direct	1/ Direct
		Max BHP	1	1	1
		RPM Range	600-1200	600-1200	600-1200
		Motor Frame Size	48	48	48
		Fan Qty / Type	1 / Centrifugal	1 / Centrifugal	1 / Centrifugal
	Fan Diameter (in)	10 x 10	10 x 10	11 x 10	
	<b>Medium Static 3 phase</b>	Motor Qty / Drive Type	1/ Belt	1/ Belt	1/ Belt
		Max BHP	1.5	1.5	2.0
		RPM Range	819-1251	920-1303	1066-1380
		Motor Frame Size	48	56	56
Fan Qty / Type		1 / Centrifugal	1 / Centrifugal	1 / Centrifugal	
Fan Diameter (in)	10 x 10	10 x 10	10 x 10		
<b>High Static 3 phase</b>	Motor Qty / Drive Type	1/ Belt	1/ Belt	1/ Belt	
	Max BHP	2.0	2.0	2.9	
	RPM Range	1035-1466	1035-1466	1208-1639	
	Motor Frame Size	56	56	56	
	Fan Qty / Type	1 / Centrifugal	1 / Centrifugal	1 / Centrifugal	
Fan Diameter (in)	10 x 10	10 x 10	10 x 10		
Cond. Coil	Material (Tube/Fin)	Cu / Al	Cu / Al	Cu / Al	
	Coil type	3/8-in RTPF	3/8-in RTPF	3/8-in RTPF	
	Rows / FPI	1 / 17	2 / 17	2 / 17	
	Total Face Area (ft <sup>2</sup> )	16.5	21.3	21.3	
Cond. fan / motor	Qty / Motor Drive Type	1/ Direct	1/ Direct	1/ Direct	
	Motor HP / RPM	1/8 / 825	1/4 / 1100	1/4 / 1100	
	Fan diameter (in)	22	22	22	
Filters	RA Filter # / Size (in)	2 / 16 x 25 x 2	4 / 16 x 16 x 2	4 / 16 x 16 x 2	
	OA inlet screen # / Size (in)	1 / 20 x 24 x 1	1 / 20 x 24 x 1	1 / 20 x 24 x 1	

**Table 6 – RHX036**

**ELECTRIC HEAT – ELECTRICAL DATA  
WITHOUT FACTORY INSTALLED NON-FUSED DISCONNECT**

NOM. V-PH-Hz.	IFM TYPE	ELECTRIC HEATER PART NUMBER CRHEATERXXXXXX	NOM PWR (kW)	APP PWR (kW)	SINGLE POINT KIT PART NUMBER CRSINGLEXXXXXX	
					NO C.O. or UNPWRD C.O.	
					NO P.E.	w/P.E. (pwrd fr/unit)
208/230-1-60	DD-STD	101A00	4.4	3.3/4.0	037	037
		102A00	6.5	4.9/6.0	040	040
		103B00	8.7	6.5/8.0	040	040
		104B00	10.5	7.9/9.6	040	040
		102A00,102A00	13.0	9.8/11.9	041	041
208/230-3-60	DD-STD	101A00	4.4	3.3/4.0	-	-
		102A00	6.5	4.9/6.0	-	-
		103B00	8.7	6.5/8.0	-	-
		104B00	10.5	7.9/9.6	037	037
		105A00	16.0	12.0/14.7	038	038
	MED	101A00	4.4	3.3/4.0	-	-
		102A00	6.5	4.9/6.0	-	-
		103B00	8.7	6.5/8.0	-	-
		104B00	10.5	7.9/9.6	037	037
		105A00	16.0	12.0/14.7	038	038
	HIGH	101A00	4.4	3.3/4.0	-	-
		102A00	6.5	4.9/6.0	-	-
		103B00	8.7	6.5/8.0	-	037
		104B00	10.5	7.9/9.6	037	037
		105A00	16.0	12.0/14.7	038	038
460-3-60	DD-STD	106A00	6.0	5.5	-	-
		107A00	8.8	8.1	-	-
		108A00	11.5	10.6	-	-
		109A00	14.0	12.9	-	-
	MED	106A00	6.0	5.5	-	-
		107A00	8.8	8.1	-	-
		108A00	11.5	10.6	-	-
		109A00	14.0	12.9	-	-
	HIGH	106A00	6.0	5.5	-	-
		107A00	8.8	8.1	-	-
		108A00	11.5	10.6	-	-
		109A00	14.0	12.9	-	-

**LEGEND**

- No Single Point Kit required
- APP PWR - 208 / 230V / 460V / 575V
- BD - Belt drive motor
- C.O. - Convenience outlet
- DD - Electric Drive X13 5 speed/torque motor
- IFM - Indoor fan motor
- NA - Not Available
- NOM PWR - 240V / 480V / 600V
- P.E. - Power exhaust
- UNPWRD - Unpowered convenience outlet

**Table 7 – RHX048**

**ELECTRIC HEAT – ELECTRICAL DATA  
WITHOUT FACTORY INSTALLED NON-FUSED DISCONNECT**

NOM. V-PH-Hz.	IFM TYPE	ELECTRIC HEATER PART NUMBER CRHEATERXXXXXX	NOM PWR (kW)	APP PWR (kW)	SINGLE POINT KIT PART NUMBER CRSINGLEXXXXXX	
					NO C.O. or UNPWRD C.O.	
					NO P.E.	w/P.E. (pwrd fr/unit)
208/230-1-60	DD-STD	101A00	4.4	3.3/4.0	037	040
		103B00	8.7	6.5/8.0	040	040
		102A00,102A00	13.0	9.8/11.9	041	041
		103B00,103B00	17.4	13.1/16.0	041	041
		104B00,104B00	21.0	15.8/19.3	041	041
208/230-3-60	DD-STD	102A00	6.5	4.9/6.0	-	-
		103B00	8.7	6.5/8.0	037	037
		105A00	16.0	12.0/14.7	038	038
		104B00,104B00	21.0	15.8/19.3	039	039
	MED	102A00	6.5	4.9/6.0	-	-
		103B00	8.7	6.5/8.0	-	037
		105A00	16.0	12.0/14.7	038	038
		104B00,104B00	21.0	15.8/19.3	039	039
	HIGH	102A00	6.5	4.9/6.0	-	-
		103B00	8.7	6.5/8.0	037	037
		105A00	16.0	12.0/14.7	038	038
		104B00,104B00	21.0	15.8/19.3	039	039
460-3-60	DD-STD	106A00	6.0	5.5	-	-
		108A00	11.5	10.6	-	-
		109A00	14.0	12.9	-	-
		108A00,108A00	23.0	21.1	037	037
	MED	106A00	6.0	5.5	-	-
		108A00	11.5	10.6	-	-
		109A00	14.0	12.9	-	-
		108A00,108A00	23.0	21.1	037	037
	HIGH	106A00	6.0	5.5	-	-
		108A00	11.5	10.6	-	-
		109A00	14.0	12.9	-	-
		108A00,108A00	23.0	21.1	037	037

**LEGEND**

- No Single Point Kit required
- APP PWR - 208 / 230V / 460V / 575V
- BD - Belt drive motor
- C.O. - Convenience outlet
- DD - Electric Drive X13 5 speed/torque motor
- IFM - Indoor fan motor
- NA - Not Available
- NOM PWR - 240V / 480V / 600V
- P.E. - Power exhaust
- UNPWRD - Unpowered convenience outlet



**Table 8 – RHX060**

**ELECTRIC HEAT – ELECTRICAL DATA  
WITHOUT FACTORY INSTALLED NON-FUSED DISCONNECT**

NOM. V-PH-Hz.	IFM TYPE	ELECTRIC HEATER PART NUMBER CRHEATERXXXXXX	NOM PWR (kW)	APP PWR (kW)	SINGLE POINT KIT PART NUMBER CRSINGLEXXXXXX	
					NO C.O. or UNPWRD C.O.	
					NO P.E.	w/P.E. (pwrd fr/unit)
208/230-1-60	DD-STD	102A00	6.5	4.9/6.0	040	040
		103B00	8.7	6.5/8.0	040	040
		102A00,102A00	13.0	9.8/11.9	041	041
		103B00,103B00	17.4	13.1/16.0	041	041
		104B00,104B00	21.0	15.8/19.3	041	041
208/230-3-60	DD-STD	102A00	6.5	4.9/6.0	-	037
		104B00	10.5	7.9/9.6	038	038
		105A00	16.0	12.0/14.7	038	038
		104B00,104B00	21.0	15.8/19.3	039	039
		104B00,105A00	26.5	19.9/24.3	039	039
	MED	102A00	6.5	4.9/6.0	-	037
		104B00	10.5	7.9/9.6	038	038
		105A00	16.0	12.0/14.7	038	038
		104B00,104B00	21.0	15.8/19.3	039	039
		104B00,105A00	26.5	19.9/24.3	039	039
	HIGH	102A00	6.5	4.9/6.0	-	037
		104B00	10.5	7.9/9.6	038	038
		105A00	16.0	12.0/14.7	038	038
		104B00,104B00	21.0	15.8/19.3	039	039
		104B00,105A00	26.5	19.9/24.3	039	039
460-3-60	DD-STD	106A00	6.0	5.5	-	-
		108A00	11.5	10.6	-	-
		109A00	14.0	12.9	-	-
		108A00,108A00	23.0	21.1	037	037
		108A00,109A00	25.5	23.4	037	037
	MED	106A00	6.0	5.5	-	-
		108A00	11.5	10.6	-	-
		109A00	14.0	12.9	-	-
		108A00,108A00	23.0	21.1	037	037
		108A00,109A00	25.5	23.4	037	037
	HIGH	106A00	6.0	5.5	-	-
		108A00	11.5	10.6	-	-
		109A00	14.0	12.9	-	-
		108A00,108A00	23.0	21.1	037	037
		108A00,109A00	25.5	23.4	037	037

**LEGEND**

- No Single Point Kit required
- APP PWR - 208 / 230V / 460V / 575V
- BD - Belt drive motor
- C.O. - Convenience outlet
- DD - Electric Drive X13 5 speed/torque motor
- IFM - Indoor fan motor
- NA - Not Available
- NOM PWR - 240V / 480V / 600V
- P.E. - Power exhaust
- UNPWRD - Unpowered convenience outlet

**Table 9 – RHX036**

**ELECTRIC HEAT – ELECTRICAL DATA  
WITH FACTORY INSTALLED NON-FUSED DISCONNECT**

NOM. V-PH-Hz.	IFM TYPE	ELECTRIC HEATER PART NUMBER CRHEATERXXXXXX	NOM PWR (kW)	APP PWR (kW)	SINGLE POINT KIT PART NUMBER CRSINGLEXXXXXX	
					NO C.O. or UNPWRD C.O.	
					NO P.E.	w/P.E. (pwrd fr/unit)
208/230-1-60	DD-STD	101A00	4.4	3.3/4.0	037	037
		102A00	6.5	4.9/6.0	040	040
		103B00	8.7	6.5/8.0	040	040
		104B00	10.5	7.9/9.6	040	040
		102A00,102A00	13.0	9.8/11.9	041	041
208/230-3-60	DD-STD	101A00	4.4	3.3/4.0	037	037
		102A00	6.5	4.9/6.0	037	037
		103B00	8.7	6.5/8.0	037	037
		104B00	10.5	7.9/9.6	037	037
		105A00	16.0	12.0/14.7	038	038
	MED	101A00	4.4	3.3/4.0	037	037
		102A00	6.5	4.9/6.0	037	037
		103B00	8.7	6.5/8.0	037	037
		104B00	10.5	7.9/9.6	037	037
		105A00	16.0	12.0/14.7	038	038
	HIGH	101A00	4.4	3.3/4.0	037	037
		102A00	6.5	4.9/6.0	037	037
		103B00	8.7	6.5/8.0	037	037
		104B00	10.5	7.9/9.6	037	037
		105A00	16.0	12.0/14.7	038	038
460-3-60	DD-STD	106A00	6.0	5.5	-	-
		107A00	8.8	8.1	-	-
		108A00	11.5	10.6	-	-
		109A00	14.0	12.9	-	-
	MED	106A00	6.0	5.5	-	-
		107A00	8.8	8.1	-	-
		108A00	11.5	10.6	-	-
		109A00	14.0	12.9	-	-
	HIGH	106A00	6.0	5.5	-	-
		107A00	8.8	8.1	-	-
		108A00	11.5	10.6	-	-
		109A00	14.0	12.9	-	-

**LEGEND**

- No Single Point Kit required
- APP PWR - 208 / 230V / 460V / 575V
- BD - Belt drive motor
- C.O. - Convenience outlet
- DD - Electric Drive X13 5 speed/torque motor
- IFM - Indoor fan motor
- NA - Not Available
- NOM PWR - 240V / 480V / 600V
- P.E. - Power exhaust
- UNPWRD - Unpowered convenience outlet

**Table 10 – RHX048**

**ELECTRIC HEAT – ELECTRICAL DATA  
WITH FACTORY INSTALLED NON-FUSED DISCONNECT**

NOM. V-PH-Hz.	IFM TYPE	ELECTRIC HEATER PART NUMBER CRHEATERXXXXXX	NOM PWR (kW)	APP PWR (kW)	SINGLE POINT KIT PART NUMBER CRSINGLEXXXXXX	
					NO C.O. or UNPWRD C.O.	
					NO P.E.	w/P.E. (pwrd fr/unit)
208/230-1-60	DD-STD	101A00	4.4	3.3/4.0	037	040
		103B00	8.7	6.5/8.0	040	040
		102A00,102A00	13.0	9.8/11.9	041	041
		103B00,103B00	17.4	13.1/16.0	041	041
		104B00,104B00	21.0	15.8/19.3	041	041
208/230-3-60	DD-STD	102A00	6.5	4.9/6.0	037	037
		103B00	8.7	6.5/8.0	037	037
		105A00	16.0	12.0/14.7	038	038
		104B00,104B00	21.0	15.8/19.3	039	039
	MED	102A00	6.5	4.9/6.0	037	037
		103B00	8.7	6.5/8.0	037	037
		105A00	16.0	12.0/14.7	038	038
		104B00,104B00	21.0	15.8/19.3	039	039
	HIGH	102A00	6.5	4.9/6.0	037	037
		103B00	8.7	6.5/8.0	037	037
		105A00	16.0	12.0/14.7	038	038
		104B00,104B00	21.0	15.8/19.3	039	039
460-3-60	DD-STD	106A00	6.0	5.5	-	-
		108A00	11.5	10.6	-	-
		109A00	14.0	12.9	-	-
		108A00,108A00	23.0	21.1	037	037
	MED	106A00	6.0	5.5	-	-
		108A00	11.5	10.6	-	-
		109A00	14.0	12.9	-	-
		108A00,108A00	23.0	21.1	037	037
	HIGH	106A00	6.0	5.5	-	-
		108A00	11.5	10.6	-	-
		109A00	14.0	12.9	-	-
		108A00,108A00	23.0	21.1	037	037

**LEGEND**

- No Single Point Kit required
- APP PWR - 208 / 230V / 460V / 575V
- BD - Belt drive motor
- C.O. - Convenience outlet
- DD - Electric Drive X13 5 speed/torque motor
- IFM - Indoor fan motor
- NA - Not Available
- NOM PWR - 240V / 480V / 600V
- P.E. - Power exhaust
- UNPWRD - Unpowered convenience outlet

**Table 11 – RHX060**

**ELECTRIC HEAT – ELECTRICAL DATA  
WITH FACTORY INSTALLED NON-FUSED DISCONNECT**

NOM. V-PH-Hz.	IFM TYPE	ELECTRIC HEATER PART NUMBER CRHEATERXXXXXX	NOM PWR (kW)	APP PWR (kW)	SINGLE POINT KIT PART NUMBER CRSINGLEXXXXXX	
					NO C.O. or UNPWRD C.O.	
					NO P.E.	w/P.E. (pwrd fr/unit)
208/230-1-60	DD-STD	102A00	6.5	4.9/6.0	040	040
		103B00	8.7	6.5/8.0	040	040
		102A00,102A00	13.0	9.8/11.9	041	041
		103B00,103B00	17.4	13.1/16.0	041	041
		104B00,104B00	21.0	15.8/19.3	041	041
208/230-3-60	DD-STD	102A00	6.5	4.9/6.0	037	037
		104B00	10.5	7.9/9.6	038	038
		105A00	16.0	12.0/14.7	038	038
		104B00,104B00	21.0	15.8/19.3	039	039
		104B00,105A00	26.5	19.9/24.3	039	039
	MED	102A00	6.5	4.9/6.0	037	037
		104B00	10.5	7.9/9.6	038	038
		105A00	16.0	12.0/14.7	038	038
		104B00,104B00	21.0	15.8/19.3	039	039
		104B00,105A00	26.5	19.9/24.3	039	039
	HIGH	102A00	6.5	4.9/6.0	037	037
		104B00	10.5	7.9/9.6	038	038
		105A00	16.0	12.0/14.7	038	038
		104B00,104B00	21.0	15.8/19.3	039	039
		104B00,105A00	26.5	19.9/24.3	039	039
460-3-60	DD-STD	106A00	6.0	5.5	-	-
		108A00	11.5	10.6	-	-
		109A00	14.0	12.9	-	-
		108A00,108A00	23.0	21.1	037	037
		108A00,109A00	25.5	23.4	037	037
	MED	106A00	6.0	5.5	-	-
		108A00	11.5	10.6	-	-
		109A00	14.0	12.9	-	-
		108A00,108A00	23.0	21.1	037	037
		108A00,109A00	25.5	23.4	037	037
	HIGH	106A00	6.0	5.5	-	-
		108A00	11.5	10.6	-	-
		109A00	14.0	12.9	-	-
		108A00,108A00	23.0	21.1	037	037
		108A00,109A00	25.5	23.4	037	037

**LEGEND**

- No Single Point Kit required
- APP PWR - 208 / 230V / 460V / 575V
- BD - Belt drive motor
- C.O. - Convenience outlet
- DD - Electric Drive X13 5 speed/torque motor
- IFM - Indoor fan motor
- NA - Not Available
- NOM PWR - 240V / 480V / 600V
- P.E. - Power exhaust
- UNPWRD - Unpowered convenience outlet

# WEIGHTS & DIMENSIONS

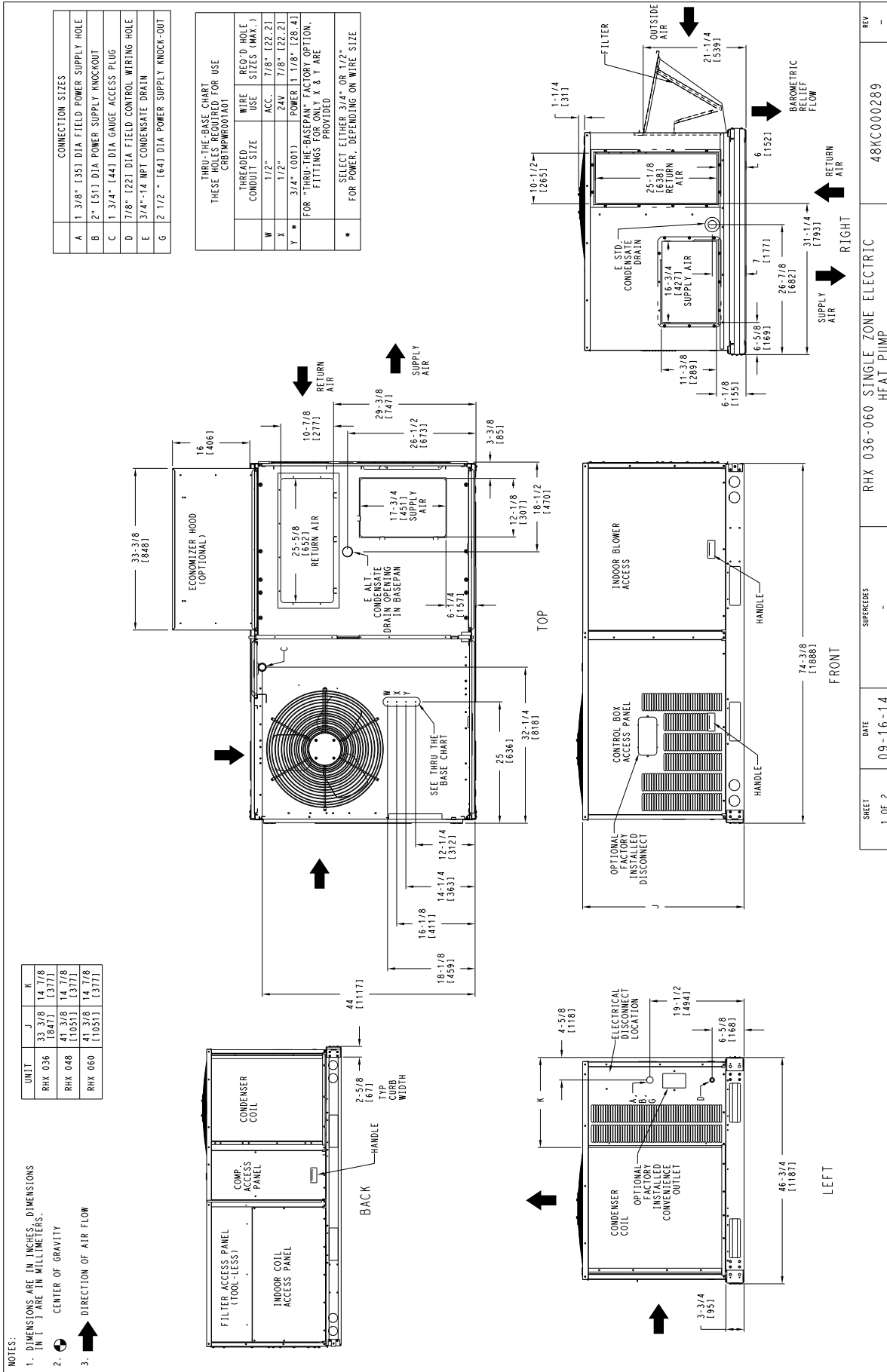

**Fig. 1 - Dimensions**

Specifications subject to change without notice.

# WEIGHTS & DIMENSIONS (cont.)

UNIT	STD. UNIT WEIGHT		CORNER WEIGHT (A)		CORNER WEIGHT (B)		CORNER WEIGHT (C)		CORNER WEIGHT (D)		C. G.			HEIGHT
	LBS.	KG.	LBS.	KG.	LBS.	KG.	LBS.	KG.	LBS.	KG.	X	Y	Z	
RHX 036	495	224	130	59	118	53	118	53	130	59	35 3/8 (898)	23 3/8 (594)	18 3/8 (467)	
RHX 048	580	263	161	73	147	66	130	59	142	64	35 1/2 (892)	21 7/8 (555)	20 1/2 (521)	
RHX 060	610	276	165	75	152	69	141	64	152	69	35 3/4 (908)	22 1/2 (571)	20 3/4 (527)	

\* STANDARD UNIT WEIGHT IS WITHOUT ELECTRIC HEAT AND WITHOUT PACKAGING. FOR OTHER OPTIONS AND ACCESSORIES, REFER TO THE PRODUCT DATA CATALOG.

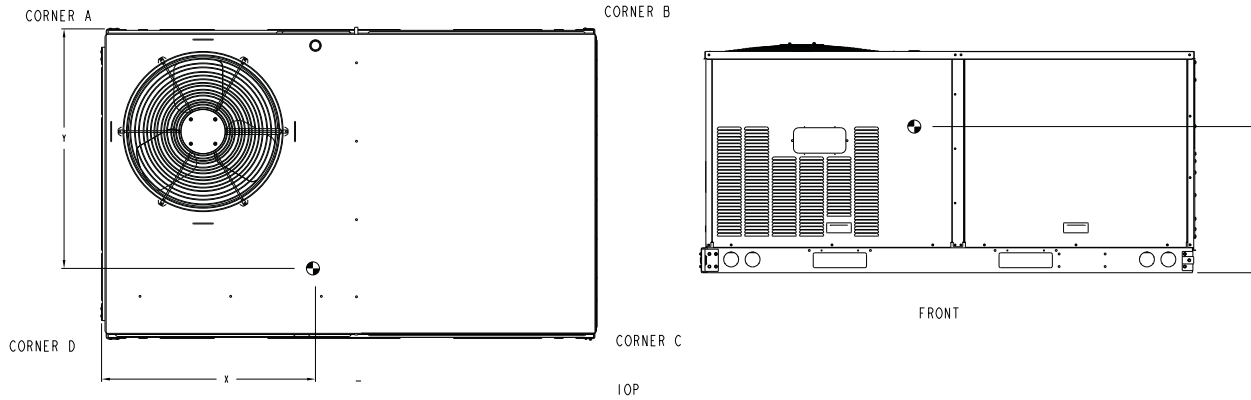

**Fig. 2 – Dimensions**

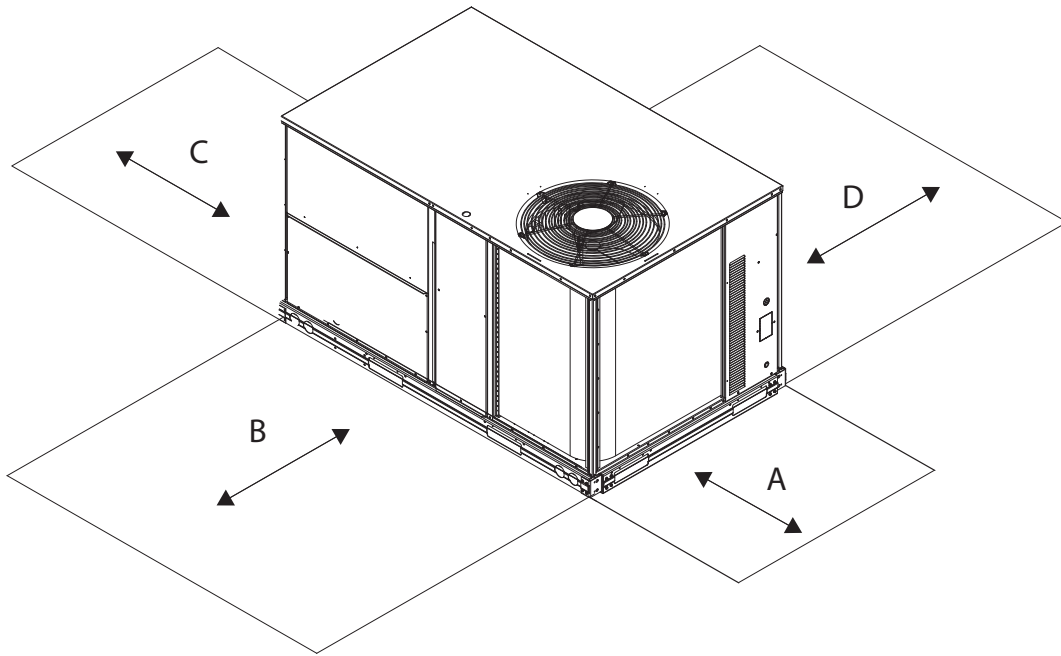

LOCATION	DIMENSION	CONDITION
A	48-in (1219 mm) 18-in (457 mm) 18-in (457 mm) 12-in (305 mm)	Unit disconnect is mounted on panel No disconnect, convenience outlet option Recommended service clearance Minimum clearance
B	42-in (1067 mm) 36-in (914 mm) Special	Surface behind servicer is grounded (e.g., metal, masonry wall) Surface behind servicer is electrically non-conductive (e.g., wood, fiberglass) Check sources of flue products within 10-ft of unit fresh air intake hood
C	36-in (914 mm) 18-in (457 mm)	Side condensate drain is used Minimum clearance
D	42-in (1067 mm) 36-in (914 mm) Special	Surface behind servicer is grounded (e.g., metal, masonry wall, another unit) Surface behind servicer is electrically non-conductive (e.g., wood, fiberglass) Check for adjacent units or building fresh air intakes within 10-ft (3 m) of this unit's flue outlet

C08337

**NOTE:**

Unit not designed to have overhead obstruction. Contact Application Engineering for guidance on any application planning overhead obstruction or for vertical clearances.

**Fig. 3 – Service Clearance**

# WEIGHTS & DIMENSIONS (cont.)

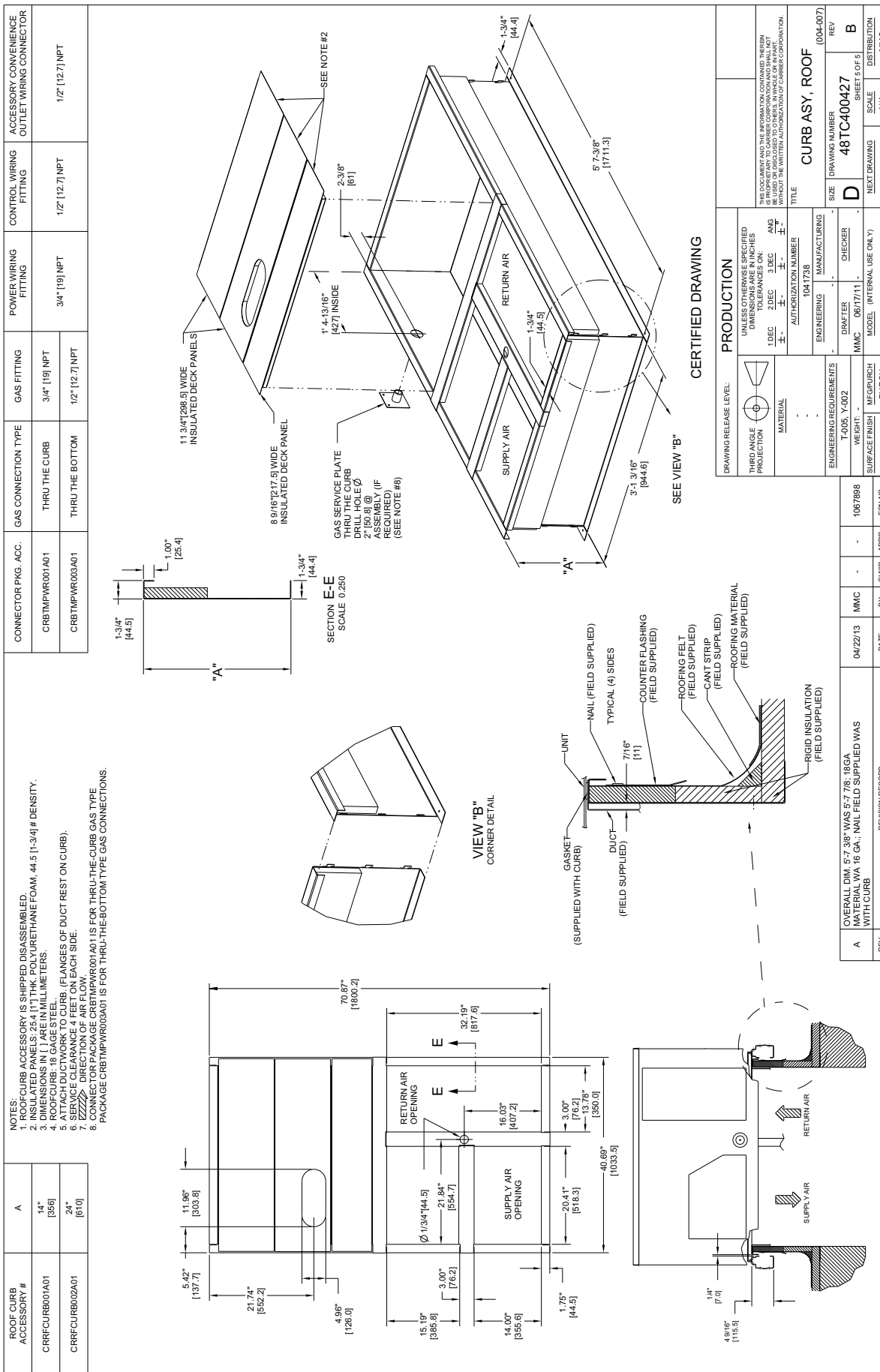

**Fig. 4 - Curb Dimensions**

Specifications subject to change without notice.

## OPTION / ACCESSORY WEIGHTS

Option / Accessory	OPTION / ACCESSORY WEIGHTS					
	36		48		60	
	lb	kg	lb	kg	lb	kg
Power Exhaust – vertical	45	20	45	22	45	20
Power Exhaust – horizontal	30	14	30	14	30	14
EconoMi\$er (IV, X or 2)	35	16	35	16	35	16
Two Position damper	39	18	39	18	39	18
Manual Dampers	12	5	12	5	12	5
Hail Guard (louvered)	13	6	13	6	17	8
Cu/Cu Condenser Coil <sup>1</sup>	37	17	95	43	95	43
Cu/Cu Condenser and Evaporator Coils <sup>1</sup>	75	34	165	75	165	75
Roof Curb (14-in. curb)	115	52	115	52	115	52
Roof Curb (24-in. curb)	197	89	197	89	197	89
CO <sub>2</sub> sensor	2	1	2	1	2	1
Electric Heater	10	5	12	5	12	5
Single Point Kit	10	5	10	5	10	5
Optional Indoor Motor/Drive	6	3	6	3	17	8
Motor Master Controller	35	16	35	16	35	16
Return Smoke Detector	7	3	7	3	7	3
Supply Smoke Detector	7	3	7	3	7	3
Non-Fused Disconnect	15	7	15	7	15	7
Non-Powered Convenience outlet	4	2	4	2	4	2
Enthalpy Sensor	2	1	2	1	2	1
Differential Enthalpy Sensor	3	1	3	1	3	1

**NOTE:** Where multiple variations are available, the heaviest combination is listed.

– Not Available

<sup>1</sup> Where available.



## APPLICATION DATA

### Min operating ambient temp (cooling):

In mechanical cooling mode, your ICP rooftop can safely operate down to an outdoor ambient temperature of 25°F (-4°C). It is possible to provide cooling at lower outdoor ambient temperatures by using less outside air, economizers, and/or accessory low ambient kits.

### Max operating ambient temp (cooling):

The maximum operating ambient temperature for cooling mode is 115°F (46°C). While cooling operation above 115°F (46°C) may be possible, it could cause either a reduction in performance, reliability, or a protective action by the unit's internal safety devices.

### Min and max airflow (cooling mode):

To maintain safe and reliable operation of your rooftop, operate within the cooling airflow limits. Operating above the max may cause blow-off, undesired airflow noise, or airflow related problems with the rooftop unit. Operating below the min may cause problems with coil freeze-up.

### Airflow:

All units are draw-through in cooling mode.

### Outdoor air application strategies:

Economizers reduce operating expenses and compressor run time by providing a free source of cooling and a means of ventilation to match application changing needs. In fact, they should be considered for most applications. Also, consider the various economizer control methods and their benefits, as well as sensors required to accomplish your application goals. Please contact your local ICP representative for assistance.

### Motor limits, Brake horsepower (BHP):

Due to ICP's internal unit design, air path, and specially designed motors, the full horsepower (maximum continuous BHP) band, as listed in this manual, can be used with the utmost confidence. There is no need for extra safety factors, as ICP's motors are designed and rigorously tested to use the entire, listed BHP range without either nuisance tripping or premature motor failure.

### Sizing a rooftop

Bigger isn't necessarily better. While an air conditioner needs to have enough capacity to meet the load, it doesn't need excess capacity. In fact, having excess capacity typically results in very poor part load performance and humidity control.

Using higher design temperatures than ASHRAE recommends for your location, adding "safety factors" to the calculated load, and rounding up to the next largest unit, are all signs of oversizing air conditioners. Oversizing can cause short-cycling, and short cycling leads to poor humidity control, reduced efficiency, higher utility bills, drastic indoor temperature swings, excessive noise, and increased wear and tear on the air conditioner.

Rather than oversizing an air conditioner, wise contractors and engineers "right-size" or even slightly undersize air conditioners. Correctly sizing an air conditioner controls humidity better; promotes efficiency; reduces utility bills; extends equipment life, and maintains even, comfortable temperatures.

### Low ambient applications

When equipped with a ICP economizer, your rooftop unit can cool your space by bringing in fresh, cool outside air. In fact, when so equipped, accessory low ambient kit may not be necessary. In low ambient conditions, unless the outdoor air is excessively humid or contaminated, economizer-based "free cooling" is the preferred less costly and energy conscious method.

In low ambient applications where outside air might not be desired (such as contaminated or excessively humid outdoor environments), your ICP rooftop can operate at ambient temperatures down to -20°F (-29°C) using the recommended accessory Motormaster low ambient controller.

**Table 12 – COOLING CAPACITIES**

**1-STAGE COOLING**

**3 TONS**

RHX036				Ambient Temperature											
				85			95			105			115		
				EA (dB)			EA (dB)			EA (dB)			EA (dB)		
				75	80	85	75	80	85	75	80	85	75	80	85
900 Cfm	EAT (wb)	58	THC	29.5	29.5	33.5	28.3	28.3	32.2	26.3	26.3	30.0	24.2	24.2	27.6
			SHC	25.4	29.5	33.5	24.5	28.3	32.2	22.7	26.3	30.0	20.8	24.2	27.6
		62	THC	31.5	31.5	31.9	29.9	29.9	31.3	27.4	27.4	29.9	24.6	24.6	28.3
			SHC	22.9	27.4	31.9	22.4	26.8	31.3	21.0	25.4	29.9	19.5	23.9	28.3
		67	THC	35.4	35.4	35.4	33.7	33.7	33.7	31.1	31.1	31.1	28.3	28.3	28.3
	SHC		18.9	23.4	27.9	18.4	22.8	27.3	17.1	21.6	26.1	15.8	20.3	24.7	
	72	THC	39.4	39.4	39.4	37.8	37.8	37.8	35.3	35.3	35.3	32.4	32.4	32.4	
		SHC	14.6	19.1	23.7	14.2	18.7	23.2	13.1	17.6	22.1	11.8	16.3	20.8	
	76	THC	-	42.1	42.1	-	40.6	40.6	-	38.3	38.3	-	35.6	35.6	
		SHC	-	15.5	20.4	-	15.2	20.2	-	14.2	19.1	-	13.0	17.8	
1050 Cfm	EAT (wb)	58	THC	31.4	31.4	35.7	30.2	30.2	34.3	28.1	28.1	32.0	25.9	25.9	29.5
			SHC	27.1	31.4	35.7	26.1	30.2	34.3	24.3	28.1	32.0	22.3	25.9	29.5
		62	THC	32.8	32.8	35.1	31.1	31.1	34.4	29.0	29.0	31.4	26.4	26.4	29.5
			SHC	24.9	30.0	35.1	24.3	29.3	34.4	22.2	26.8	31.4	20.5	25.0	29.5
		67	THC	36.8	36.8	36.8	35.0	35.0	35.0	32.2	32.2	32.2	29.3	29.3	29.3
	SHC		20.2	25.3	30.5	19.7	24.8	30.0	18.4	23.5	28.7	17.1	22.2	27.3	
	72	THC	40.5	40.5	40.5	39.0	39.0	39.0	36.4	36.4	36.4	33.6	33.6	33.6	
		SHC	15.1	20.3	25.4	14.8	19.9	25.1	13.6	18.8	23.9	12.4	17.6	22.7	
	76	THC	-	43.0	43.0	-	41.5	41.5	-	39.1	39.1	-	36.5	36.5	
		SHC	-	16.2	21.9	-	15.8	21.4	-	14.8	20.3	-	13.6	19.0	
1200 Cfm	EAT (wb)	58	THC	33.1	33.1	37.6	31.8	31.8	36.1	29.7	29.7	33.7	27.3	27.3	31.1
			SHC	28.6	33.1	37.6	27.5	31.8	36.1	25.6	29.7	33.7	23.5	27.3	31.1
		62	THC	33.8	33.8	38.0	32.2	32.2	36.9	30.5	30.5	32.5	27.4	27.4	32.4
			SHC	26.7	32.4	38.0	25.8	31.4	36.9	23.1	27.8	32.5	22.3	27.4	32.4
		67	THC	37.8	37.8	37.8	36.0	36.0	36.0	33.1	33.1	33.1	30.1	30.1	30.1
	SHC		21.4	27.1	32.9	20.9	26.7	32.5	19.6	25.4	31.2	18.3	24.0	29.8	
	72	THC	41.3	41.3	41.3	39.8	39.8	39.8	37.3	37.3	37.3	34.4	34.4	34.4	
		SHC	15.5	21.2	26.9	15.2	20.9	26.7	14.1	19.9	25.6	12.9	18.7	24.5	
	76	THC	-	43.7	43.7	-	42.1	42.1	-	39.7	39.7	-	37.1	37.1	
		SHC	-	16.6	22.8	-	16.3	22.4	-	15.2	21.3	-	14.1	20.1	
1350 Cfm	EAT (wb)	58	THC	34.5	34.5	39.2	33.2	33.2	37.6	30.9	30.9	35.2	28.6	28.6	32.5
			SHC	29.8	34.5	39.2	28.7	33.2	37.6	26.7	30.9	35.2	24.6	28.6	32.5
		62	THC	34.7	34.7	40.9	33.2	33.2	39.2	31.7	31.7	33.9	28.6	28.6	33.8
			SHC	28.4	34.7	40.9	27.3	33.2	39.2	24.1	29.0	33.9	23.3	28.6	33.8
		67	THC	38.6	38.6	38.6	36.8	36.8	36.8	33.9	33.9	33.9	30.7	30.7	32.2
	SHC		22.4	28.8	35.1	22.0	28.4	34.8	20.8	27.2	33.7	19.4	25.8	32.2	
	72	THC	42.0	42.0	42.0	40.4	40.4	40.4	37.9	37.9	37.9	35.0	35.0	35.0	
		SHC	15.9	22.1	28.3	15.6	21.8	28.1	14.5	20.8	27.2	13.3	19.7	26.1	
	76	THC	-	44.2	44.2	-	42.6	42.6	-	40.2	40.2	-	37.5	37.5	
		SHC	-	17.0	23.6	-	16.6	23.2	-	15.6	22.1	-	14.5	21.0	
1500 Cfm	EAT (wb)	58	THC	35.8	35.8	40.6	34.4	34.4	39.0	32.1	32.1	36.4	29.6	29.6	33.7
			SHC	30.9	35.8	40.6	29.8	34.4	39.0	27.7	32.1	36.4	25.5	29.6	33.7
		62	THC	35.9	35.9	42.3	34.5	34.5	40.7	32.1	32.1	37.9	29.6	29.6	35.1
			SHC	29.4	35.9	42.3	28.3	34.5	40.7	26.3	32.1	37.9	24.2	29.6	35.1
		67	THC	39.2	39.2	39.2	37.4	37.4	37.4	34.5	34.5	35.9	31.3	31.3	34.5
	SHC		23.4	30.3	37.2	23.1	30.0	37.0	21.8	28.9	35.9	20.4	27.5	34.5	
	72	THC	42.5	42.5	42.5	40.9	40.9	40.9	38.4	38.4	38.4	35.5	35.5	35.5	
		SHC	16.2	22.8	29.5	15.9	22.6	29.4	14.8	21.7	28.5	13.7	20.6	27.6	
	76	THC	-	44.6	44.6	-	43.0	43.0	-	40.5	40.5	-	37.8	37.8	
		SHC	-	17.3	24.4	-	16.9	24.0	-	15.9	22.9	-	14.9	21.8	

**LEGEND**

- Do not operate in this region (Points are outside SST and SDT permissible operating range)
- Cfm - Cubic feet per minute (supply air)
- EAT(db) - Entering air temperature (dry bulb)
- EAT(wb) - Entering air temperature (wet bulb)
- SHC - Sensible heat capacity
- THC - Total capacity

**Table 13 – COOLING CAPACITIES**

**1-STAGE COOLING**

**4 TONS**

RHX048				Ambient Temperature											
				85			95			105			115		
				EA (dB)			EA (dB)			EA (dB)			EA (dB)		
				75	80	85	75	80	85	75	80	85	75	80	85
1200 Cfm	EAT (wb)	58	THC	41.5	41.5	47.0	39.6	39.6	44.8	37.5	37.5	42.5	35.2	35.2	39.9
			SHC	36.0	41.5	47.0	34.4	39.6	44.8	32.6	37.5	42.5	30.6	35.2	39.9
		62	THC	44.3	44.3	44.6	41.6	41.6	43.3	38.9	38.9	42.0	35.9	35.9	40.5
			SHC	32.6	38.6	44.6	31.4	37.4	43.3	30.1	36.1	42.0	28.7	34.6	40.5
		67	THC	49.2	49.2	49.2	46.5	46.5	46.5	43.4	43.4	43.4	40.4	40.4	40.4
			SHC	27.1	33.1	39.1	26.0	32.0	38.1	24.7	30.7	36.7	23.4	29.5	35.5
		72	THC	52.2	52.2	52.2	51.1	51.1	51.1	48.6	48.6	48.6	45.4	45.4	45.4
			SHC	20.6	26.5	32.4	20.2	26.2	32.2	19.2	25.3	31.3	18.0	24.1	30.1
		76	THC	-	53.2	53.2	-	52.9	52.9	-	51.6	51.6	-	49.1	49.1
			SHC	-	21.0	27.6	-	20.9	27.5	-	20.4	27.0	-	19.5	25.9
1400 Cfm	EAT (wb)	58	THC	44.0	44.0	49.9	41.9	41.9	47.5	39.7	39.7	44.9	37.3	37.3	42.2
			SHC	38.2	44.0	49.9	36.4	41.9	47.5	34.5	39.7	44.9	32.4	37.3	42.2
		62	THC	45.9	45.9	48.9	43.1	43.1	47.5	40.3	40.3	45.9	37.4	37.4	44.0
			SHC	35.1	42.0	48.9	33.8	40.6	47.5	32.4	39.2	45.9	30.8	37.4	44.0
		67	THC	50.6	50.6	50.6	48.2	48.2	48.2	44.8	44.8	44.8	41.6	41.6	41.6
			SHC	28.5	35.2	42.0	27.6	34.5	41.4	26.3	33.2	40.1	25.0	31.9	38.8
		72	THC	52.6	52.6	52.6	52.0	52.0	52.0	49.9	49.9	49.9	46.8	46.8	46.8
			SHC	20.8	27.2	33.6	20.6	27.3	34.0	19.8	26.7	33.6	18.7	25.6	32.5
		76	THC	-	53.4	53.4	-	53.3	53.3	-	52.1	52.1	-	49.9	49.9
			SHC	-	21.6	29.3	-	21.5	29.2	-	21.0	28.4	-	20.2	27.4
1600 Cfm	EAT (wb)	58	THC	46.2	46.2	52.4	43.9	43.9	49.7	41.6	41.6	47.0	39.0	39.0	44.2
			SHC	40.1	46.2	52.4	38.1	43.9	49.7	36.1	41.6	47.0	33.9	39.0	44.2
		62	THC	47.3	47.3	52.7	44.4	44.4	51.1	42.3	42.3	46.4	39.1	39.1	46.0
			SHC	37.4	45.1	52.7	36.0	43.6	51.1	33.1	39.7	46.4	32.2	39.1	46.0
		67	THC	51.3	51.3	51.3	49.3	49.3	49.3	46.0	46.0	46.0	42.5	42.5	42.5
			SHC	29.5	36.9	44.3	29.1	36.7	44.4	27.8	35.6	43.4	26.5	34.3	42.1
		72	THC	52.8	52.8	52.8	52.5	52.5	52.5	50.8	50.8	50.8	47.7	47.7	47.7
			SHC	20.9	27.7	34.6	20.8	28.1	35.4	20.3	27.9	35.5	19.2	27.0	34.7
		76	THC	-	53.6	53.6	-	53.6	53.6	-	52.5	52.5	-	50.4	50.4
			SHC	-	21.9	30.3	-	21.8	29.9	-	21.3	29.3	-	20.6	28.6
1800 Cfm	EAT (wb)	58	THC	48.0	48.0	54.3	45.7	45.7	51.8	43.1	43.1	48.8	40.5	40.5	45.9
			SHC	41.6	48.0	54.3	39.7	45.7	51.8	37.4	43.1	48.8	35.2	40.5	45.9
		62	THC	48.9	48.9	53.8	46.4	46.4	52.7	43.7	43.7	48.6	40.6	40.6	47.7
			SHC	38.3	46.0	53.8	37.2	45.0	52.7	34.5	41.6	48.6	33.4	40.6	47.7
		67	THC	51.8	51.8	51.8	50.2	50.2	50.2	47.0	47.0	47.0	43.3	43.3	45.2
			SHC	30.3	38.3	46.2	30.3	38.8	47.2	29.3	37.9	46.5	27.9	36.5	45.2
		72	THC	53.0	53.0	53.0	52.7	52.7	52.7	51.3	51.3	51.3	48.4	48.4	48.4
			SHC	20.9	28.2	35.5	21.0	28.8	36.5	20.6	28.8	37.1	19.7	28.2	36.7
		76	THC	-	53.7	53.7	-	53.7	53.7	-	52.7	52.7	-	50.7	50.7
			SHC	-	22.0	30.8	-	22.0	30.5	-	21.6	30.1	-	21.0	29.6
2000 Cfm	EAT (wb)	58	THC	49.4	49.4	55.9	47.3	47.3	53.5	44.6	44.6	50.4	41.8	41.8	47.4
			SHC	42.9	49.4	55.9	41.0	47.3	53.5	38.7	44.6	50.4	36.3	41.8	47.4
		62	THC	49.8	49.8	57.6	48.1	48.1	52.2	44.6	44.6	52.5	41.9	41.9	49.3
			SHC	40.5	49.0	57.6	37.3	44.8	52.2	36.7	44.6	52.5	34.5	41.9	49.3
		67	THC	52.0	52.0	52.0	50.8	50.8	50.8	47.7	47.7	49.4	44.0	44.0	48.2
			SHC	30.9	39.4	47.8	31.4	40.5	49.7	30.6	40.0	49.4	29.3	38.7	48.2
		72	THC	53.1	53.1	53.1	52.9	52.9	52.9	51.6	51.6	51.6	48.9	48.9	48.9
			SHC	21.0	28.6	36.2	21.0	29.3	37.5	20.8	29.6	38.5	20.0	29.3	38.5
		76	THC	-	53.8	53.8	-	53.8	53.8	-	52.9	52.9	-	51.0	51.0
			SHC	-	22.1	31.2	-	22.1	31.1	-	21.8	30.8	-	21.3	30.4

**LEGEND**

- Do not operate in this region (Points are outside SST and SDT permissible operating range)
- Cfm - Cubic feet per minute (supply air)
- EAT(db) - Entering air temperature (dry bulb)
- EAT(wb) - Entering air temperature (wet bulb)
- SHC - Sensible heat capacity
- THC - Total capacity

**Table 14 – COOLING CAPACITIES**

**1-STAGE COOLING**

**5 TONS**

RHX060				Ambient Temperature											
				85			95			105			115		
				EA (dB)			EA (dB)			EA (dB)			EA (dB)		
				75	80	85	75	80	85	75	80	85	75	80	85
1500 Cfm	EAT (wb)	58	THC	51.1	51.1	57.8	48.9	48.9	55.3	46.4	46.4	52.5	43.5	43.5	49.2
			SHC	44.3	51.1	57.8	42.4	48.9	55.3	40.2	46.4	52.5	37.7	43.5	49.2
		62	THC	53.5	53.5	55.7	50.7	50.7	54.3	47.5	47.5	52.7	44.6	44.6	48.5
			SHC	40.3	48.0	55.7	39.0	46.7	54.3	37.5	45.1	52.7	34.6	41.6	48.5
		67	THC	59.1	59.1	59.1	56.1	56.1	56.1	52.8	52.8	52.8	48.9	48.9	48.9
	SHC		33.1	40.9	48.6	31.9	39.6	47.3	30.5	38.2	45.9	28.9	36.6	44.4	
	72	THC	65.4	65.4	65.4	62.3	62.3	62.3	58.6	58.6	58.6	54.7	54.7	54.7	
		SHC	25.7	33.5	41.3	24.6	32.4	40.2	23.2	30.9	38.7	21.7	29.4	37.2	
	76	THC	-	70.1	70.1	-	67.2	67.2	-	63.9	63.9	-	60.3	60.3	
		SHC	-	27.4	35.7	-	26.4	34.5	-	25.1	33.1	-	23.9	31.8	
1750 Cfm	EAT (wb)	58	THC	53.9	53.9	61.1	51.6	51.6	58.5	49.0	49.0	55.5	46.2	46.2	52.3
			SHC	46.8	53.9	61.1	44.8	51.6	58.5	42.5	49.0	55.5	40.1	46.2	52.3
		62	THC	53.3	53.3	57.6	50.3	50.3	55.9	47.1	47.1	54.1	44.6	44.6	49.1
			SHC	41.2	49.4	57.6	39.7	47.8	55.9	38.1	46.1	54.1	35.0	42.0	49.1
		67	THC	61.4	61.4	61.4	57.8	57.8	57.8	54.3	54.3	54.3	50.7	50.7	50.7
	SHC		35.3	44.3	53.2	33.9	42.8	51.7	32.5	41.4	50.3	31.0	40.0	48.9	
	72	THC	67.5	67.5	67.5	64.1	64.1	64.1	60.4	60.4	60.4	56.6	56.6	56.6	
		SHC	26.6	35.5	44.5	25.4	34.3	43.3	24.0	33.0	42.0	22.6	31.5	40.5	
	76	THC	-	72.0	72.0	-	68.8	68.8	-	65.4	65.4	-	61.8	61.8	
		SHC	-	28.4	37.7	-	27.3	36.5	-	26.1	35.2	-	24.8	33.9	
2000 Cfm	EAT (wb)	58	THC	56.6	56.6	64.1	53.9	53.9	61.0	51.2	51.2	57.9	48.3	48.3	54.7
			SHC	49.1	56.6	64.1	46.8	53.9	61.0	44.4	51.2	57.9	41.9	48.3	54.7
		62	THC	54.7	54.7	61.8	52.1	52.1	57.3	49.6	49.6	53.0	45.9	45.9	54.0
			SHC	43.7	52.7	61.8	40.8	49.1	57.3	38.1	45.5	53.0	37.8	45.9	54.0
		67	THC	60.2	60.2	60.2	56.8	56.8	56.8	53.4	53.4	53.4	49.8	49.8	49.8
	SHC		35.3	44.6	53.8	33.9	43.2	52.5	32.6	41.8	51.1	31.2	40.5	49.7	
	72	THC	68.8	68.8	68.8	65.4	65.4	65.4	61.7	61.7	61.7	57.8	57.8	57.8	
		SHC	27.2	37.2	47.2	26.0	36.1	46.1	24.7	34.8	44.9	23.3	33.4	43.5	
	76	THC	-	73.0	73.0	-	69.9	69.9	-	66.5	66.5	-	62.9	62.9	
		SHC	-	29.0	39.3	-	28.0	38.3	-	26.8	37.1	-	25.6	35.9	
2250 Cfm	EAT (wb)	58	THC	58.7	58.7	66.5	55.9	55.9	63.3	53.0	53.0	60.0	50.1	50.1	56.7
			SHC	51.0	58.7	66.5	48.5	55.9	63.3	46.0	53.0	60.0	43.5	50.1	56.7
		62	THC	59.6	59.6	66.1	56.7	56.7	62.7	53.1	53.1	62.4	50.1	50.1	59.0
			SHC	47.0	56.5	66.1	44.6	53.6	62.7	43.7	53.1	62.4	41.3	50.1	59.0
		67	THC	63.9	63.9	63.9	60.1	60.1	60.1	56.3	56.3	58.4	52.6	52.6	56.9
	SHC		39.0	50.1	61.3	37.6	48.7	59.9	36.1	47.3	58.4	34.7	45.8	56.9	
	72	THC	69.9	69.9	69.9	66.4	66.4	66.4	62.7	62.7	62.7	58.8	58.8	58.8	
		SHC	27.8	38.8	49.8	26.6	37.7	48.8	25.3	36.5	47.7	24.0	35.2	46.5	
	76	THC	-	73.5	73.5	-	70.8	70.8	-	67.3	67.3	-	63.7	63.7	
		SHC	-	29.5	40.7	-	28.6	39.9	-	27.5	38.8	-	26.3	37.6	
2500 Cfm	EAT (wb)	58	THC	60.6	60.6	68.6	57.6	57.6	65.2	54.6	54.6	61.8	51.6	51.6	58.4
			SHC	52.6	60.6	68.6	50.0	57.6	65.2	47.4	54.6	61.8	44.8	51.6	58.4
		62	THC	61.0	61.0	70.4	57.6	57.6	67.8	54.7	54.7	64.3	51.7	51.7	60.8
			SHC	49.5	60.0	70.4	47.4	57.6	67.8	45.0	54.7	64.3	42.5	51.7	60.8
		67	THC	64.8	64.8	65.0	61.0	61.0	63.9	57.1	57.1	62.2	53.3	53.3	60.6
	SHC		40.6	52.8	65.0	39.3	51.6	63.9	37.8	50.0	62.2	36.4	48.5	60.6	
	72	THC	70.7	70.7	70.7	67.2	67.2	67.2	63.5	63.5	63.5	59.5	59.5	59.5	
		SHC	28.2	40.2	52.3	27.0	39.2	51.3	25.8	38.1	50.4	24.5	36.9	49.2	
	76	THC	-	73.8	73.8	-	71.5	71.5	-	68.0	68.0	-	64.3	64.3	
		SHC	-	29.8	41.8	-	29.2	41.4	-	28.1	40.3	-	26.9	39.2	

**LEGEND**

- Do not operate in this region (Points are outside SST and SDT permissible operating range)
- Cfm - Cubic feet per minute (supply air)
- EAT(db) - Entering air temperature (dry bulb)
- EAT(wb) - Entering air temperature (wet bulb)
- SHC - Sensible heat capacity
- THC - Total capacity

**Table 15 – HEATING CAPACITIES**

**3 TONS**

RETURN AIR (°F db)		CFM (STANDARD AIR)		RHX036							
				TEMPERATURE AIR ENTERING OUTDOOR COIL (°F db AT 70% RH)							
				-10	0	10	17	30	40	47	50
55	900	Capacity	9.3	12.8	16.6	19.4	26.4	31.0	34.8	36.4	42.3
		Int. Cap.	8.6	11.8	15.2	17.7	23.1	31.0	34.8	36.4	42.3
	1200	Capacity	9.5	13.3	17.1	20.1	27.7	32.4	36.3	37.9	43.9
		Int. Cap.	8.8	12.3	15.7	18.3	24.3	32.4	36.3	37.9	43.9
	1500	Capacity	10.2	13.8	18.0	21.0	27.3	32.7	36.4	38.2	43.3
		Int. Cap.	9.4	12.7	16.5	19.1	23.9	32.7	36.4	38.2	43.3
70	900	Capacity	6.7	10.3	14.2	16.9	23.2	28.1	32.3	34.0	40.0
		Int. Cap.	6.2	9.5	13.1	15.4	20.3	28.1	32.3	34.0	40.0
	1200	Capacity	7.3	11.1	15.1	18.1	24.6	29.9	34.1	35.8	41.7
		Int. Cap.	6.7	10.2	13.8	16.5	21.5	29.9	34.1	35.8	41.7
	1500	Capacity	7.7	11.7	15.5	18.8	26.0	31.1	35.0	36.8	42.7
		Int. Cap.	7.1	10.7	14.3	17.1	22.8	31.1	35.0	36.8	42.7
80	900	Capacity	4.9	8.6	12.3	15.5	21.4	26.4	30.0	31.8	40.7
		Int. Cap.	4.5	7.9	11.3	14.1	18.8	26.4	30.0	31.8	40.7
	1200	Capacity	5.4	9.1	13.1	16.2	22.8	27.9	32.2	34.1	40.1
		Int. Cap.	5.0	8.4	12.1	14.7	20.0	27.9	32.2	34.1	40.1
	1500	Capacity	5.8	9.7	13.9	16.8	23.6	28.8	33.4	35.1	41.1
		Int. Cap.	5.4	8.9	12.8	15.3	20.6	28.8	33.4	35.1	41.1

**LEGEND**

- Capacity – Instantaneous Capacity (1000 Btuh) includes indoor fan motor heat @AHRI static conditions
- Int. Cap. – Integrated Capacity is Instantaneous Capacity minus the effects of frost on the outdoor coil and the heat required to defrost
- RH – Relative Humidity
- db – Dry Bulb

**Table 16 – HEATING CAPACITIES**

**4 TONS**

RETURN AIR (°F db)		CFM (STANDARD AIR)		RHX048							
				TEMPERATURE AIR ENTERING OUTDOOR COIL (°F db AT 70% RH)							
				-10	0	10	17	30	40	47	50
55	1200	Capacity	17.8	22.3	27.5	31.0	40.0	45.9	51.1	53.4	61.2
		Int. Cap.	16.5	20.5	25.2	28.3	35.0	45.9	51.1	53.4	61.2
	1600	Capacity	23.0	23.0	28.2	31.9	40.2	47.2	52.5	54.6	61.4
		Int. Cap.	21.3	21.2	25.8	29.0	35.3	47.2	52.5	54.6	61.4
	2000	Capacity	18.8	23.7	28.8	32.5	41.0	47.9	52.5	54.4	60.8
		Int. Cap.	17.4	21.8	26.4	29.7	35.9	47.9	52.5	54.4	60.8
70	1200	Capacity	16.2	20.6	25.6	29.4	36.4	42.9	48.4	50.7	58.8
		Int. Cap.	15.0	18.9	23.5	26.8	31.9	42.9	48.4	50.7	58.8
	1600	Capacity	16.9	21.3	26.8	30.3	37.6	44.8	49.9	52.3	59.8
		Int. Cap.	15.6	19.6	24.6	27.6	32.9	44.8	49.9	52.3	59.8
	2000	Capacity	17.4	22.0	27.5	31.0	38.8	45.7	50.8	52.9	59.7
		Int. Cap.	16.1	20.2	25.2	28.3	34.0	45.7	50.8	52.9	59.7
80	1200	Capacity	14.6	19.1	23.9	28.2	35.0	41.0	46.2	48.6	56.9
		Int. Cap.	13.5	17.6	21.9	25.7	30.7	41.0	46.2	48.6	56.9
	1600	Capacity	15.4	19.8	25.0	29.2	36.3	42.7	48.2	50.5	58.4
		Int. Cap.	14.2	18.3	23.0	26.6	31.8	42.7	48.2	50.5	58.4
	2000	Capacity	16.1	20.7	25.9	29.9	37.2	43.8	49.1	51.4	58.6
		Int. Cap.	14.9	19.0	23.7	27.3	32.6	43.8	49.1	51.4	58.6

**LEGEND**

- Capacity – Instantaneous Capacity (1000 Btuh) includes indoor fan motor heat @AHRI static conditions
- Int. Cap. – Integrated Capacity is Instantaneous Capacity minus the effects of frost on the outdoor coil and the heat required to defrost
- RH – Relative Humidity
- db – Dry Bulb

**Table 17 – HEATING CAPACITY**

**5 TONS**

RETURN AIR (°F db)		CFM (STANDARD AIR)	RHX060								
			TEMPERATURE AIR ENTERING OUTDOOR COIL (°F db AT 70% RH)								
			-10	0	10	17	30	40	47	50	60
55	1500	Capacity	17.7	23.0	28.8	33.0	42.4	49.8	55.6	58.3	67.5
		Int. Cap.	16.4	21.2	26.4	30.1	37.2	49.8	55.6	58.3	67.5
	2000	Capacity	18.7	24.1	29.9	34.3	44.7	52.4	58.4	61.0	69.7
		Int. Cap.	17.3	22.1	27.5	31.3	39.2	52.4	58.4	61.0	69.7
	2500	Capacity	19.6	25.0	31.1	35.7	44.5	52.3	57.6	59.8	67.0
		Int. Cap.	18.1	23.0	28.6	32.6	39.0	52.3	57.6	59.8	67.0
70	1500	Capacity	15.0	20.4	26.1	30.3	40.4	48.5	54.0	56.6	65.7
		Int. Cap.	13.8	18.8	23.9	27.6	35.4	48.5	54.0	56.6	65.7
	2000	Capacity	15.9	21.5	27.2	31.6	44.2	50.2	55.9	58.6	67.6
		Int. Cap.	14.7	19.8	25.0	28.8	38.7	50.2	55.9	58.6	67.6
	2500	Capacity	16.8	22.5	28.5	32.9	43.9	51.5	57.3	59.9	68.0
		Int. Cap.	15.6	20.7	26.2	30.0	38.5	51.5	57.3	59.9	68.0
80	1500	Capacity	12.9	18.5	24.5	28.8	38.3	46.7	52.1	54.6	63.5
		Int. Cap.	11.9	17.0	22.5	26.3	33.6	46.7	52.1	54.6	63.5
	2000	Capacity	13.8	19.6	25.6	30.0	38.6	47.1	52.6	55.2	63.7
		Int. Cap.	12.8	18.0	23.5	27.3	33.9	47.1	52.6	55.2	63.7
	2500	Capacity	14.8	20.6	26.9	31.3	41.5	49.9	55.6	58.2	66.6
		Int. Cap.	13.7	19.0	24.7	28.6	36.4	49.9	55.6	58.2	66.6

**LEGEND**

- Capacity – Instantaneous Capacity (1000 Btuh) includes indoor fan motor heat @AHRI static conditions
- Int. Cap. – Integrated Capacity is Instantaneous Capacity minus the effects of frost on the outdoor coil and the heat required to defrost
- RH – Relative Humidity
- db – Dry Bulb

**Table 18 – STATIC PRESSURE ADDERS (FACTORY OPTIONS AND/OR ACCESSORIES)**

3-5 TONS											
CFM	600	900	1200	1400	1600	1800	2000	2200	2400	2600	
1 Electric Heater Module	0.03	0.05	0.07	0.09	0.09	0.10	0.11	0.11	0.12	0.13	
2 Electric Heater Modules	0.13	0.15	0.16	0.16	0.16	0.17	0.17	0.17	0.18	0.18	

3-5 TONS										
CFM	600	800	1000	1250	1500	1750	2000	2250	2500	
Vertical Economizer	0.012	0.020	0.030	0.046	0.066	0.089	0.115	0.145	0.179	
Horizontal Economizer	0.018	0.026	0.037	0.053	0.073	0.096	0.124	0.154	0.189	

All above data for both standard and ultra low leak models, where available.

3-5 TONS						
Power Exhaust Performance						
Return Duct Static Pressure (in wg)	0.0	0.1	0.2	0.3	0.4	0.5
Vertical Power Exhaust CFM	3239	2974	2642	2244	1780	1249

**GENERAL FAN PERFORMANCE NOTES**

1. Interpolation is permissible. Do not extrapolate.
2. External static pressure is the static pressure difference between the return duct and the supply duct plus the static pressure caused by any FIOPs or accessories.
3. Tabular data accounts for pressure loss due to clean filters, unit casing, and wet coils. Factory options and accessories may add static pressure losses, as shown in Table 18. Selection software is available, through your salesperson, to help you select the best motor/drive combination for your application.
4. The Fan Performance tables offer motor/drive recommendations. In cases when two motor/drive combinations would work, ICP recommended the lower horsepower option.
5. For information on the electrical properties of ICP motors, please see the Electrical information section of this book.
6. For more information on the performance limits of ICP motors, see the application data section of this book.

## FAN PERFORMANCE (DIRECT DRIVE)

**Table 19 – RHX036 Vertical Unit – Direct Drive**

Speed (Torque) tap	CFM	ESP	BHP
1	900	0.44	0.19
	975	0.34	0.18
	1050	0.24	0.17
	1125	0.15	0.16
	1200	0.07	0.16
	1275	-	-
	1350	-	-
	1425	-	-
	1500	-	-
2	900	0.60	0.24
	975	0.49	0.23
	1050	0.38	0.22
	1125	0.28	0.21
	1200	0.18	0.20
	1275	0.09	0.19
	1350	-	-
	1425	-	-
	1500	-	-
3	900	0.93	0.36
	975	0.81	0.35
	1050	0.70	0.34
	1125	0.58	0.33
	1200	0.47	0.31
	1275	0.36	0.30
	1350	0.25	0.29
	1425	0.14	0.27
	1500	-	-
4	900	1.15	0.44
	975	1.07	0.45
	1050	0.97	0.46
	1125	0.86	0.46
	1200	0.74	0.43
	1275	0.61	0.41
	1350	0.48	0.40
	1425	0.35	0.39
	1500	0.23	0.37
5	900	1.24	0.51
	975	1.19	0.52
	1050	1.24	0.54
	1125	1.24	0.57
	1200	1.03	0.59
	1275	0.98	0.61
	1350	0.93	0.64
	1425	0.88	0.67
	1500	0.82	0.69

**Table 20 – RHX036 Horizontal Unit – Direct Drive**

Speed (Torque) tap	CFM	ESP	BHP
1	900	0.57	0.25
	975	0.47	0.24
	1050	0.37	0.22
	1125	0.27	0.21
	1200	0.18	0.20
	1275	0.09	0.20
	1350	-	-
	1425	-	-
	1500	-	-
2	900	0.73	0.30
	975	0.62	0.29
	1050	0.51	0.28
	1125	0.41	0.27
	1200	0.30	0.25
	1275	0.19	0.24
	1350	0.08	0.22
	1425	-	-
	1500	-	-
3	900	1.04	0.41
	975	0.93	0.40
	1050	0.82	0.39
	1125	0.70	0.38
	1200	0.58	0.36
	1275	0.46	0.35
	1350	0.34	0.33
	1425	0.23	0.31
	1500	0.12	0.30
4	900	1.26	0.49
	975	1.18	0.50
	1050	1.09	0.50
	1125	0.99	0.50
	1200	0.88	0.49
	1275	0.76	0.47
	1350	0.63	0.46
	1425	0.50	0.44
	1500	0.37	0.42
5	900	1.35	0.52
	975	1.30	0.54
	1050	1.26	0.57
	1125	1.21	0.59
	1200	1.16	0.62
	1275	1.12	0.64
	1350	1.07	0.67
	1425	1.02	0.70
	1500	0.97	0.73

# FAN PERFORMANCE (DIRECT DRIVE) (cont.)

**Table 21 – RHX048 Vertical Unit – Direct Drive**

Speed (Torque) tap	CFM	ESP	BHP
1	1200	0.87	0.43
	1300	0.73	0.41
	1400	0.59	0.39
	1500	0.43	0.37
	1600	0.27	0.34
	1700	0.12	0.33
	1800	-	-
	1900	-	-
	2000	-	-
2	1200	0.96	0.48
	1300	0.84	0.46
	1400	0.69	0.44
	1500	0.53	0.41
	1600	0.37	0.39
	1700	0.21	0.36
	1800	0.06	0.34
	1900	-	-
	2000	-	-
3	1200	1.13	0.53
	1300	1.06	0.53
	1400	0.98	0.54
	1500	0.88	0.56
	1600	0.76	0.54
	1700	0.62	0.52
	1800	0.47	0.50
	1900	0.31	0.47
	2000	0.15	0.45
4	1200	1.16	0.57
	1300	1.12	0.59
	1400	1.07	0.62
	1500	1.00	0.67
	1600	0.91	0.66
	1700	0.80	0.67
	1800	0.67	0.67
	1900	0.52	0.63
	2000	0.35	0.61
5	1200	1.16	0.59
	1300	1.11	0.63
	1400	1.01	0.67
	1500	0.91	0.67
	1600	0.96	0.75
	1700	0.91	0.75
	1800	0.86	0.83
	1900	0.80	0.87
	2000	0.74	0.91

**Table 22 – RHX048 Horizontal Unit – Direct Drive**

Speed (Torque) tap	CFM	ESP	BHP
1	1200	0.93	0.48
	1300	0.80	0.46
	1400	0.66	0.44
	1500	0.51	0.41
	1600	0.36	0.39
	1700	0.22	0.36
	1800	0.08	0.33
	1900	-	-
	2000	-	-
2	1200	1.04	0.53
	1300	0.91	0.51
	1400	0.76	0.48
	1500	0.61	0.46
	1600	0.45	0.43
	1700	0.30	0.40
	1800	0.16	0.38
	1900	0.04	0.35
	2000	-	-
3	1200	1.18	0.58
	1300	1.09	0.59
	1400	0.98	0.60
	1500	0.86	0.60
	1600	0.72	0.57
	1700	0.57	0.54
	1800	0.42	0.51
	1900	0.28	0.48
	2000	0.15	0.45
4	1200	1.24	0.60
	1300	1.18	0.63
	1400	1.12	0.66
	1500	1.04	0.71
	1600	0.95	0.70
	1700	0.85	0.71
	1800	0.73	0.71
	1900	0.60	0.69
	2000	0.45	0.65
5	1200	1.25	0.61
	1300	1.20	0.65
	1400	1.12	0.68
	1500	1.04	0.68
	1600	1.05	0.76
	1700	1.01	0.76
	1800	0.96	0.84
	1900	0.91	0.89
	2000	0.87	0.93



## FAN PERFORMANCE (DIRECT DRIVE) (cont.)

**Table 23 – RHX060 Vertical Unit – Direct Drive**

Speed (Torque) tap	CFM	ESP	BHP
1	1500	0.27	0.32
	1625	0.13	0.30
	1750	-	-
	1875	-	-
	2000	-	-
	2125	-	-
	2250	-	-
	2375	-	-
	2500	-	-
2	1500	0.42	0.40
	1625	0.25	0.37
	1750	0.08	0.34
	1875	-	-
	2000	-	-
	2125	-	-
	2250	-	-
	2375	-	-
	2500	-	-
3	1500	1.11	0.79
	1625	0.91	0.76
	1750	0.70	0.74
	1875	0.50	0.70
	2000	0.30	0.67
	2125	0.12	0.63
	2250	-	-
	2375	-	-
	2500	-	-
4	1500	1.29	0.90
	1625	1.13	0.88
	1750	0.95	0.91
	1875	0.74	0.88
	2000	0.52	0.84
	2125	0.30	0.80
	2250	0.11	0.77
	2375	-	-
	2500	-	-
5	1500	1.36	0.94
	1625	1.24	0.99
	1750	0.95	1.02
	1875	0.74	1.05
	2000	0.74	1.03
	2125	0.53	0.99
	2250	0.31	0.94
	2375	0.08	0.90
	2500	-	0.86

**Table 24 – RHX060 Horizontal Unit – Direct Drive**

Speed (Torque) tap	CFM	ESP	BHP
1	1500	0.37	0.35
	1625	0.22	0.33
	1750	0.08	0.31
	1875	-	-
	2000	-	-
	2125	-	-
	2250	-	-
	2375	-	-
	2500	-	-
2	1500	0.54	0.44
	1625	0.37	0.41
	1750	0.20	0.38
	1875	0.04	0.35
	2000	-	-
	2125	-	-
	2250	-	-
	2375	-	-
	2500	-	-
3	1500	1.28	0.83
	1625	1.10	0.81
	1750	0.90	0.78
	1875	0.68	0.74
	2000	0.47	0.70
	2125	0.27	0.66
	2250	0.10	0.62
	2375	-	-
	2500	-	-
4	1500	1.46	0.94
	1625	1.32	0.92
	1750	1.16	0.96
	1875	0.96	0.95
	2000	0.76	0.91
	2125	0.54	0.86
	2250	0.33	0.82
	2375	0.14	0.78
	2500	0.00	0.72
5	1500	1.52	0.97
	1625	1.42	1.01
	1750	1.16	1.05
	1875	0.96	1.09
	2000	1.00	1.09
	2125	0.82	1.06
	2250	0.62	1.02
	2375	0.40	0.98
	2500	0.16	0.93

# FAN PERFORMANCE – BELT DRIVE

**Table 25 – RHX036**

**3 TON VERTICAL SUPPLY**

CFM	Available External Static Pressure (in. wg)									
	0.2		0.4		0.6		0.8		1.0	
	RPM	BHP	RPM	BHP	RPM	BHP	RPM	BHP	RPM	BHP
900	594	0.15	740	0.25	867	0.37	981	0.52	1084	0.68
975	618	0.17	758	0.28	881	0.40	991	0.55	1092	0.71
1050	642	0.19	777	0.30	896	0.43	1003	0.58	1102	0.75
1125	668	0.22	797	0.34	912	0.47	1017	0.62	1113	0.79
1200	695	0.25	818	0.37	930	0.51	1032	0.66	1126	0.83
1275	722	0.29	841	0.41	949	0.55	1048	0.71	1140	0.88
1350	750	0.33	864	0.46	968	0.60	1065	0.76	1155	0.93
1425	778	0.37	888	0.50	989	0.65	1083	0.81	1171	0.99
1500	807	0.42	913	0.56	1011	0.71	1103	0.87	1188	1.05

CFM	Available External Static Pressure (in. wg)									
	1.2		1.4		1.6		1.8		2.0	
	RPM	BHP	RPM	BHP	RPM	BHP	RPM	BHP	RPM	BHP
900	1180	0.86	1269	1.05	1354	1.25	1434	1.47	1511	<b>1.70</b>
975	1186	0.89	1275	1.08	1358	1.29	1437	1.51	1513	<b>1.74</b>
1050	1194	0.92	1281	1.12	1363	1.32	1441	1.54	1516	<b>1.78</b>
1125	1204	0.97	1289	1.16	1370	1.37	1447	1.59	1520	<b>1.82</b>
1200	1215	1.01	1298	1.21	1378	1.42	1454	1.64	1526	<b>1.87</b>
1275	1227	1.06	1309	1.26	1387	1.47	1462	1.69	1533	<b>1.92</b>
1350	1240	1.12	1321	1.32	1397	1.53	1471	1.75	1541	<b>1.99</b>
1425	1254	1.18	1333	1.38	1409	1.59	1481	1.82	-	-
1500	1270	1.24	1347	1.45	1421	1.66	1492	1.89	-	-

Med static – 819–1251 RPM, Max BHP 1.5

High static – 1035–1466 RPM, Max BHP 2.0

**Bold Face** indicates field-supplied drive

Recommend using field-supplied fan pulley (part no. KR11AD561), motor pulley (part no. KR11HY181) and belt (part no. KR29AF041).

**Table 26 – RHX036**

**3 TON HORIZONTAL SUPPLY**

CFM	Available External Static Pressure (in. wg)									
	0.2		0.4		0.6		0.8		1.0	
	RPM	BHP	RPM	BHP	RPM	BHP	RPM	BHP	RPM	BHP
900	574	0.13	707	0.23	817	0.34	913	0.47	999	0.61
975	597	0.15	727	0.25	835	0.37	929	0.50	1015	0.64
1050	621	0.18	747	0.28	853	0.40	946	0.53	1030	0.68
1125	646	0.20	768	0.31	872	0.43	964	0.57	1047	0.72
1200	671	0.23	790	0.34	892	0.47	982	0.61	1064	0.76
1275	696	0.26	812	0.38	912	0.51	1001	0.65	1082	0.81
1350	723	0.30	835	0.42	933	0.55	1020	0.70	1100	0.86
1425	749	0.34	859	0.46	955	0.60	1040	0.75	1119	0.91
1500	776	0.38	883	0.51	977	0.65	1061	0.80	1138	0.97

CFM	Available External Static Pressure (in. wg)									
	1.2		1.4		1.6		1.8		2.0	
	RPM	BHP	RPM	BHP	RPM	BHP	RPM	BHP	RPM	BHP
900	1078	0.77	1151	0.93	1220	1.11	1284	1.30	1346	1.49
975	1093	0.80	1165	0.97	1233	1.15	1297	1.33	1358	1.53
1050	1108	0.84	1180	1.01	1247	1.19	1311	1.38	1371	1.58
1125	1123	0.88	1195	1.05	1261	1.23	1325	1.42	1385	1.62
1200	1140	0.92	1210	1.10	1276	1.28	1339	1.47	1399	1.68
1275	1157	0.97	1226	1.15	1292	1.33	1354	1.53	1414	1.73
1350	1174	1.02	1243	1.20	1308	1.39	1370	1.59	1429	1.80
1425	1192	1.08	1260	1.26	1325	1.45	1386	1.65	1444	1.86
1500	1210	1.14	1278	1.33	1342	1.52	1403	1.72	1461	1.93

Med static – 819–1251 RPM, Max BHP 1.5

High static – 1035–1466 RPM, Max BHP 2.0

# FAN PERFORMANCE – BELT DRIVE (cont.)

**Table 27 – RHX048**

## 4 TON VERTICAL SUPPLY

CFM	Available External Static Pressure (in. wg)									
	0.2		0.4		0.6		0.8		1.0	
	RPM	BHP	RPM	BHP	RPM	BHP	RPM	BHP	RPM	BHP
1200	682	0.25	800	0.36	897	0.48	982	0.61	1058	0.75
1300	717	0.29	832	0.42	928	0.55	1011	0.68	1086	0.82
1400	753	0.34	865	0.48	956	0.61	1041	0.76	1115	0.91
1500	789	0.40	898	0.54	990	0.69	1071	0.84	1144	1.00
1600	826	0.47	932	0.62	1022	0.77	1102	0.93	1175	1.09
1700	863	0.54	966	0.70	1055	0.86	1133	1.03	1205	1.20
1800	901	0.62	1001	0.79	1088	0.96	1165	1.13	1235	1.31
1900	939	0.71	1037	0.89	1121	1.07	1197	1.25	1267	1.44
2000	978	0.81	1073	0.99	1156	1.18	1230	1.37	1299	1.57

CFM	Available External Static Pressure (in. wg)									
	1.2		1.4		1.6		1.8		2.0	
	RPM	BHP	RPM	BHP	RPM	BHP	RPM	BHP	RPM	BHP
900	1128	0.89	1192	1.03	1252	1.18	1309	1.34	1363	1.50
975	1155	0.97	1219	1.12	1279	1.28	1336	1.44	1389	1.61
1050	1183	1.06	1247	1.22	1306	1.38	1362	1.55	1416	1.72
1125	1212	1.16	1275	1.32	1334	1.49	1389	1.67	1443	1.85
1200	1241	1.26	1303	1.43	1362	1.61	1417	1.79	1470	1.98
1275	1271	1.37	1332	1.55	1390	1.74	1445	1.93	1498	2.12
1350	1301	1.50	1362	1.68	1419	1.87	1474	2.07	1526	2.27
1425	1331	1.63	1392	1.82	1449	2.02	1503	2.22	-	-
1500	1362	1.77	1422	1.97	1478	2.18	1532	2.38	-	-

Med static – 920–1303 RPM, Max BHP 1.5

High static – 1035–1466 RPM, Max BHP 2.0

*ITALICS* – indicates field-supplied motor and drive required, recommend using field supplied motor (HD58FE651–230v and 460v, HD58FE576–575 volt), fan pulley (part no. KR11AZ606), motor pulley (part no. KR11HY213), and belt (KR29AF043)

**Table 28 – RHX048**

## 4 TON HORIZONTAL SUPPLY

CFM	Available External Static Pressure (in. wg)									
	0.2		0.4		0.6		0.8		1.0	
	RPM	BHP	RPM	BHP	RPM	BHP	RPM	BHP	RPM	BHP
1200	630	0.20	755	0.31	859	0.43	949	0.56	1030	0.70
1300	659	0.24	781	0.36	883	0.48	972	0.61	1052	0.76
1400	689	0.28	808	0.40	908	0.53	995	0.67	1075	0.82
1500	720	0.33	836	0.46	933	0.59	1020	0.74	1098	0.89
1600	752	0.38	864	0.52	960	0.66	1044	0.81	1121	0.97
1700	784	0.44	893	0.58	986	0.73	1070	0.89	1146	1.05
1800	816	0.50	922	0.65	1014	0.81	1096	0.97	1171	1.14
1900	849	0.58	952	0.73	1042	0.90	1122	1.07	1196	1.24
2000	882	0.66	982	0.82	1070	0.99	1149	1.17	1222	1.35

CFM	Available External Static Pressure (in. wg)									
	1.2		1.4		1.6		1.8		2.0	
	RPM	BHP	RPM	BHP	RPM	BHP	RPM	BHP	RPM	BHP
1200	1104	0.84	1173	0.99	1237	1.15	1298	1.32	1356	1.49
1300	1125	0.91	1194	1.06	1258	1.23	1318	1.40	1375	1.58
1400	1147	0.98	1215	1.14	1278	1.31	1338	1.48	1395	1.67
1500	1170	1.05	1237	1.22	1299	1.39	1359	1.57	1416	1.76
1600	1193	1.13	1259	1.31	1321	1.49	1380	1.67	1437	1.86
1700	1216	1.22	1282	1.40	1344	1.59	1402	1.78	1458	1.97
1800	1240	1.32	1305	1.50	1366	1.69	1424	1.89	1480	2.09
1900	1265	1.43	1329	1.61	1390	1.81	1447	2.01	1502	2.22
2000	1290	1.54	1353	1.73	1413	1.93	1470	2.14	1525	2.35

Med static – 920–1303 RPM, Max BHP 1.5

High static – 1035–1466 RPM, Max BHP 2.0

*ITALICS* – indicates field-supplied motor and drive required, recommend using field supplied motor (HD58FE651–230v and 460v, HD58FE576–575 volt), fan pulley (part no. KR11AZ606), motor pulley (part no. KR11HY213), and belt (KR29AF043)

# FAN PERFORMANCE – BELT DRIVE (cont.)

**Table 29 – RHX060**

**5 TON VERTICAL SUPPLY**

CFM	Available External Static Pressure (in. wg)									
	0.2		0.4		0.6		0.8		1.0	
	RPM	BHP	RPM	BHP	RPM	BHP	RPM	BHP	RPM	BHP
1500	794	0.41	902	0.55	993	0.69	1074	0.85	1147	1.00
1625	840	0.49	945	0.64	1034	0.80	1113	0.96	1185	1.13
1750	888	0.59	988	0.75	1075	0.92	1153	1.09	1223	1.26
1875	936	0.70	1033	0.87	1117	1.05	1193	1.23	1263	1.41
2000	984	0.82	1078	1.00	1160	1.19	1235	1.39	1303	1.58
2125	1033	0.96	1124	1.15	1204	1.35	1277	1.56	1343	1.76
2250	1083	1.11	1170	1.32	1248	1.53	1319	1.74	1385	1.96
2375	1133	1.28	1217	1.50	1293	1.72	1363	1.95	1427	2.17
2500	1183	1.47	1265	1.70	1339	1.93	1406	2.17	1470	2.41

CFM	Available External Static Pressure (in. wg)									
	1.2		1.4		1.6		1.8		2.0	
	RPM	BHP	RPM	BHP	RPM	BHP	RPM	BHP	RPM	BHP
1500	1214	1.16	1277	1.33	1336	1.50	1392	1.67	1445	1.85
1625	1251	1.30	1313	1.47	1371	1.65	1427	1.83	1479	2.02
1750	1289	1.44	1350	1.63	1407	1.81	1462	2.01	1514	2.20
1875	1327	1.60	1387	1.80	1444	1.99	1498	2.19	1550	2.40
2000	1366	1.78	1426	1.98	1482	2.19	1535	2.40	1586	2.61
2125	1406	1.97	1464	2.18	1520	2.40	1573	2.62	1623	2.84
2250	1446	2.18	1504	2.40	1559	2.62	1611	2.85	-	-
2375	1487	2.40	1544	2.63	1598	2.87	-	-	-	-
2500	1529	2.64	1585	2.89	-	-	-	-	-	-

Med static – 1066–1380 RPM, Max BHP 2.0

High static – 1208–1639 RPM, Max BHP 2.9

**Table 30 – RHX060**

**5 TON HORIZONTAL SUPPLY**

CFM	Available External Static Pressure (in. wg)									
	0.2		0.4		0.6		0.8		1.0	
	RPM	BHP	RPM	BHP	RPM	BHP	RPM	BHP	RPM	BHP
1500	725	0.33	840	0.46	937	0.60	1023	0.75	1101	0.90
1625	765	0.40	876	0.54	970	0.68	1054	0.84	1131	1.00
1750	806	0.48	912	0.63	1004	0.78	1087	0.94	1162	1.11
1875	847	0.57	950	0.72	1039	0.88	1120	1.05	1194	1.23
2000	889	0.66	988	0.83	1075	1.00	1154	1.18	1226	1.36
2125	931	0.78	1027	0.95	1112	1.13	1189	1.31	1260	1.50
2250	974	0.90	1067	1.08	1149	1.27	1224	1.46	1294	1.66
2375	1018	1.03	1107	1.23	1187	1.43	1261	1.63	1329	1.84
2500	1061	1.19	1148	1.39	1226	1.59	1297	1.81	1364	2.02

CFM	Available External Static Pressure (in. wg)									
	1.2		1.4		1.6		1.8		2.0	
	RPM	BHP	RPM	BHP	RPM	BHP	RPM	BHP	RPM	BHP
1500	1172	1.06	1239	1.23	1302	1.40	1361	1.58	1418	1.77
1625	1201	1.16	1267	1.34	1329	1.52	1388	1.71	1444	1.90
1750	1231	1.28	1296	1.46	1358	1.65	1416	1.84	1472	2.04
1875	1262	1.41	1326	1.60	1387	1.79	1445	1.99	1499	2.20
2000	1294	1.55	1357	1.74	1417	1.95	1474	2.15	1528	2.36
2125	1326	1.70	1388	1.90	1447	2.11	1504	2.33	1557	2.55
2250	1359	1.87	1420	2.08	1479	2.29	1534	2.51	1587	2.74
2375	1393	2.05	1453	2.27	1511	2.49	1566	2.72	-	-
2500	1427	2.24	1487	2.47	1543	2.70	-	-	-	-

Med static – 1066–1380 RPM, Max BHP 2.0

High static – 1208–1639 RPM, Max BHP 2.9

**Table 31 – PULLEY ADJUSTMENT – BELT DRIVE**

UNIT	Motor/Drive Combo	Motor Pulley turns open										
		0	0.5	1	1.5	2	2.5	3	3.5	4	4.5	5
36	Medium Static	1251	1208	1165	1121	1078	1035	992	949	905	862	819
	High Static	1466	1423	1380	1337	1294	1251	1207	1164	1121	1078	1035
48	Medium Static	1303	1265	1226	1188	1150	1112	1073	1035	997	958	920
	High Static	1466	1423	1380	1337	1294	1251	1207	1164	1121	1078	1035
60	Medium Static	1380	1349	1317	1286	1254	1223	1192	1160	1129	1097	1066
	High Static	1639	1596	1553	1510	1467	1424	1380	1337	1294	1251	1208

**NOTE:** Do not adjust pulley further than 5 turns open.

■ – Factory settings

\* Do not set motor pulley above 5 turns open for A or AX section belts

\*\* Do not set motor pulley below 1 turn open for B or BX section belts

# ELECTRICAL INFORMATION

**Table 32 – RHX036**
**SINGLE STAGE COOLING WITH SINGLE SPEED INDOOR FAN MOTOR**

V-Ph-Hz	VOLTAGE RANGE		COMP (ea)		OFM (ea)		IFM		
	MIN	MAX	RLA	LRA	WATTS	FLA	TYPE	EFF at Full Load	FLA
208-1-60	187	253	16.6	79	190	1.0	DD-STD	78%	7.4
230-1-60	187	253	16.6	79	190	1.0	DD-STD	78%	7.4
208-3-60	187	253	10.4	73	190	1.0	DD-STD	78%	7.4
					190	1.0	MED	87%	5.2
					190	1.0	HIGH	89%	8.4
230-3-60	187	253	10.4	73	190	1.0	DD-STD	78%	7.4
					190	1.0	MED	87%	4.9
					190	1.0	HIGH	89%	8.3
460-3-60	414	506	5.8	38	190	0.5	DD-STD	78%	4.0
					190	0.5	MED	87%	2.5
					190	0.5	HIGH	89%	4.2
575-3-60	518	633	3.8	37	190	0.5	DD-STD	78%	4.0
					190	0.5	MED	72%	1.6
					190	0.5	HIGH	77%	2.8

**Table 33 – RHX048**
**SINGLE STAGE COOLING WITH SINGLE SPEED INDOOR FAN MOTOR**

V-Ph-Hz	VOLTAGE RANGE		COMP (ea)		OFM (ea)		IFM		
	MIN	MAX	RLA	LRA	WATTS	FLA	TYPE	EFF at Full Load	FLA
208-1-60	187	253	21.8	117	325	1.4	DD-STD	78%	7.4
230-1-60	187	253	21.8	117	325	1.4	DD-STD	78%	7.4
208-3-60	187	253	13.7	83	325	1.4	DD-STD	78%	7.4
					325	1.4	MED	87%	5.2
					325	1.4	HIGH	89%	8.4
230-3-60	187	253	13.7	83	325	1.4	DD-STD	78%	7.4
					325	1.4	MED	87%	4.9
					325	1.4	HIGH	89%	8.3
460-3-60	414	506	6.2	41	325	0.8	DD-STD	78%	4.0
					325	0.8	MED	87%	2.5
					325	0.8	HIGH	89%	4.2
575-3-60	518	633	4.8	33	325	0.8	DD-STD	78%	4.0
					325	0.8	MED	72%	1.6
					325	0.8	HIGH	77%	2.8

**Table 34 – RHX060**
**SINGLE STAGE COOLING WITH SINGLE SPEED INDOOR FAN MOTOR**

V-Ph-Hz	VOLTAGE RANGE		COMP (ea)		OFM (ea)		IFM		
	MIN	MAX	RLA	LRA	WATTS	FLA	TYPE	EFF at Full Load	FLA
208-1-60	187	253	23.7	153	325	1.4	DD-STD	78%	7.4
230-1-60	187	253	23.7	153	325	1.4	DD-STD	78%	7.4
208-3-60	187	253	15.9	110	325	1.4	DD-STD	78%	7.4
					325	1.4	MED	89%	8.4
					325	1.4	HIGH	89%	8.4
230-3-60	187	253	15.9	110	325	1.4	DD-STD	78%	7.4
					325	1.4	MED	89%	8.3
					325	1.4	HIGH	89%	8.3
460-3-60	414	506	7.0	52	325	0.8	DD-STD	78%	4.0
					325	0.8	MED	89%	4.2
					325	0.8	HIGH	89%	4.2
575-3-60	518	633	5.1	40	325	0.8	DD-STD	78%	4.0
					325	0.8	MED	77%	2.8
					325	0.8	HIGH	77%	2.8

**Legend and Notes for Table 35**

**LEGEND:**

- BRKR - Circuit breaker
- CO - Convenient outlet
- DD - Direct drive (indoor fan motor)
- DISC - Disconnect
- FLA - Full load amps
- IFM - Indoor fan motor
- LRA - Locked rotor amps
- MCA - Minimum circuit amps
- MOCP - MAX FUSE or HACR Breaker
- PE - Power exhaust
- UNPWR CO - Unpowered convenient outlet

**NOTES:**

1. In compliance with NEC requirements for multimotor and combination load equipment (refer to NEC Articles 430 and 440), the overcurrent protective device for the unit shall be fuse or HACR breaker. Canadian units may be fuse or circuit breaker.

**2. Unbalanced 3-Phase Supply Voltage**

Never operate a motor where a phase imbalance in supply voltage is greater than 2%. Use the following formula to determine the percentage of voltage imbalance.

$$\% \text{ Voltage Imbalance} = 100 \times \frac{\text{max voltage deviation from average voltage}}{\text{average voltage}}$$

Example: Supply voltage is 230-3-60



- AB = 224 v
- BC = 231 v
- AC = 226 v

$$\begin{aligned} \text{Average Voltage} &= \frac{(224 + 231 + 226)}{3} = \frac{681}{3} \\ &= 227 \end{aligned}$$

Determine maximum deviation from average voltage.

(AB)  $227 - 224 = 3 \text{ v}$

(BC)  $231 - 227 = 4 \text{ v}$

(AC)  $227 - 226 = 1 \text{ v}$

Maximum deviation is 4 v.

Determine percent of voltage imbalance.

$$\begin{aligned} \% \text{ Voltage Imbalance} &= 100 \times \frac{4}{227} \\ &= 1.76\% \end{aligned}$$

This amount of phase imbalance is satisfactory as it is below the maximum allowable 2%.

**IMPORTANT:** If the supply voltage phase imbalance is more than 2%, contact your local electric utility company immediately.

**Table 35 – UNIT WIRE/FUSE OR HACR BREAKER SIZING DATA**

UNIT	NO M. V-Ph-HZ	IFM TYPE	ELEC. HTR			NO C.O. or UNPWR C.O.							
			CRHEATER***A00	Nom (kW)	FLA	NO P.E.				w/ P.E. (pwrd fr/unit)			
						MCA	MAX FUSE or HACR BRKR	DISC. SIZE		MCA	MAX FUSE or HACR BRKR	DISC. SIZE	
								FLA	LRA			FLA	LRA
RH036	208/230-1-60	DD-STD	NONE	-	-	30	45	29	88	32	45	31	90
			101A	3.3/4.4	15.9/18.3	49/52	60/60	47/50	104/106	51/54	60/60	49/52	106/108
			102A	4.9/6.5	23.5/27.1	59/63	60/70	56/60	112/115	61/65	70/70	58/62	114/117
			103B	6.5/8.7	31.4/36.3	69/75	70/80	65/70	119/124	71/77	80/80	67/73	121/126
			104B	7.9/10.5	37.9/43.8	77/84	80/90	72/79	126/132	79/86	80/90	75/81	128/134
			102A+102A	9.8/13.0	46.9/54.2	88/97	90/100	83/91	182/196	90/99	90/100	85/93	184/198
	208/230-3-60	DD-STD	NONE	-	-	22	30	22	82	24	30	24	84
			101A	3.3/4.4	9.2/10.6	33/35	40/40	32/34	91/93	35/37	40/40	34/36	93/95
			102A	4.9/6.5	13.6/15.6	39/41	45/45	37/40	96/98	41/43	45/45	39/42	98/100
			103B	6.5/8.7	18.1/20.9	44/48	45/50	42/46	100/103	46/50	50/50	45/48	102/105
			104B	7.9/10.5	21.9/25.3	49/53	50/60	47/51	104/107	51/55	60/60	49/53	106/109
			105A	12.0/16.0	33.4/38.5	64/70	70/70	60/66	115/121	66/72	70/80	62/68	117/123
		MED	NONE	-	-	20/19	25/25	19/19	111	22/21	30/30	21/21	113
			101A	3.3/4.4	9.2/10.6	31/33	35/35	30/31	120/122	33/35	40/40	32/33	122/124
			102A	4.9/6.5	13.6/15.6	37/39	40/40	35/37	125/127	39/41	45/45	37/39	127/129
			103B	6.5/8.7	18.1/20.9	42/45	45/50	40/43	129/132	44/47	45/50	42/45	131/134
			104B	7.9/10.5	21.9/25.3	47/51	50/60	44/48	133/136	49/53	50/60	46/50	135/138
		105A	12.0/16.0	33.4/38.5	61/67	70/70	58/63	144/150	63/69	70/70	60/65	146/152	
		HIGH	NONE	-	-	23/23	30/30	23/23	147	25/25	30/30	25/25	149
			101A	3.3/4.4	9.2/10.6	34/36	40/40	33/35	156/158	36/38	40/45	36/37	158/160
102A	4.9/6.5		13.6/15.6	40/42	45/45	38/41	161/163	42/44	45/50	41/43	163/165		
103B	6.5/8.7		18.1/20.9	45/49	50/50	44/47	165/168	47/51	50/60	46/49	167/170		
104B	7.9/10.5		21.9/25.3	50/54	50/60	48/52	169/172	52/56	60/60	50/54	171/174		
105A	12.0/16.0	33.4/38.5	65/71	70/80	61/67	180/186	67/73	70/80	63/69	182/188			
RH036	460-3-60	DD-STD	NONE	-	-	12	15	12	43	13	15	13	44
			106A	6.0	7.2	21	25	20	50	22	25	21	51
			107A	8.8	10.6	25	25	24	54	26	30	25	55
			108A	11.5	13.8	29	30	28	57	30	30	29	58
			109A	14.0	16.8	33	35	31	60	34	35	32	61
	MED	NONE	-	-	11	15	10	57	12	15	11	58	
		106A	6.0	7.2	20	20	18	64	21	25	20	65	
		107A	8.8	10.6	24	25	22	68	25	25	23	69	
		108A	11.5	13.8	28	30	26	71	29	30	27	72	
		109A	14.0	16.8	32	35	29	74	33	35	31	75	
	HIGH	NONE	-	-	12	15	12	75	13	15	13	76	
		106A	6.0	7.2	21	25	20	82	22	25	22	83	
		107A	8.8	10.6	26	30	24	86	27	30	25	87	
		108A	11.5	13.8	30	30	28	89	31	35	29	90	
		109A	14.0	16.8	33	35	31	92	34	35	33	93	
575-3-60	DD-STD	NONE	-	-	10	15	10	42	12	15	12	44	
	MED	NONE	-	-	7	15	7	45	9	15	9	47	
	HIGH	NONE	-	-	9	15	8	60	10	15	10	62	

See "Legend and Notes for Table 35 on page 30.

**Table 35 – Unit Wire/Fuse or HACR Breaker Sizing Data (cont)**

UNIT	NO M. V-PH-HZ	IFM TYPE	ELEC. HTR			NO C.O. or UNPWR C.O.								
			CRHEATER***A00	Nom (kW)	FLA	NO P.E.				w/ P.E. (pwrd fr/unit)				
						MCA	MAX FUSE or HACR BRKR	DISC. SIZE		MCA	MAX FUSE or HACR BRKR	DISC. SIZE		
								FLA	LRA			FLA	LRA	
RHX048	208/230-1-60	DD-STD	101A	3.3/4.4	15.9/18.3	56/59	60/60	53/56	143/145	58/61	60/70	56/58	145/147	
			103B	6.5/8.7	31.4/36.3	76/82	80/90	71/77	158/163	78/84	80/90	73/79	160/165	
			102A+102A	9.8/13.0	46.9/54.2	95/104	100/110	89/98	221/235	97/106	100/110	91/100	223/237	
			103B+103B	13.1/17.4	62.8/72.5	115/127	125/150	107/119	253/272	117/129	125/150	110/121	255/274	
			104B+104B	15.8/21.0	75.8/87.5	131/146	150/150	122/136	279/302	133/148	150/150	125/138	281/304	
	RHX048	208/230-3-60	DD-STD	NONE	-	-	26	30	26	93	28	40	28	95
				102A	4.9/6.5	13.6/15.6	43/46	50/50	42/44	107/109	45/48	50/50	44/46	109/111
				103B	6.5/8.7	18.1/20.9	49/53	50/60	47/50	111/114	51/54	60/60	49/52	113/116
				105A	12.0/16.0	33.4/38.5	68/75	70/80	64/70	126/132	70/76	70/80	66/72	128/134
				104B+104B	15.8/21.0	43.8/50.5	81/90	90/90	76/84	181/194	83/91	90/100	78/86	183/196
		MED	NONE	-	-	24/24	30/30	23/23	122	26/26	30/30	26/25	124	
			102A	4.9/6.5	13.6/15.6	41/43	50/50	39/41	136/138	43/45	50/50	41/43	138/140	
			103B	6.5/8.7	18.1/20.9	47/50	50/50	44/47	140/143	49/52	50/60	46/49	142/145	
			105A	12.0/16.0	33.4/38.5	66/72	70/80	62/67	155/161	68/74	70/80	64/69	157/163	
			104B+104B	15.8/21.0	43.8/50.5	79/87	80/90	74/81	210/223	81/89	90/90	76/83	212/225	
HIGH		NONE	-	-	27/27	40/40	27/27	158	29/29	40/40	29/29	160		
		102A	4.9/6.5	13.6/15.6	44/47	50/50	43/45	172/174	46/49	50/50	45/47	174/176		
		103B	6.5/8.7	18.1/20.9	50/53	50/60	48/51	176/179	52/55	60/60	50/53	178/181		
		105A	12.0/16.0	33.4/38.5	69/75	70/80	65/71	191/197	71/77	80/80	68/73	193/199		
		104B+104B	15.8/21.0	43.8/50.5	82/90	90/90	77/85	246/259	84/92	90/100	80/87	248/261		
RHX048	460-3-60	DD-STD	NONE	-	-	13	15	13	47	14	20	14	48	
			106A	6.0	7.2	22	25	21	54	23	25	22	55	
			108A	11.5	13.8	30	30	29	61	31	35	30	62	
			109A	14.0	16.8	34	35	32	64	35	35	33	65	
			108A+108A	23.0	27.7	48	50	45	102	49	50	46	103	
	MED	NONE	-	-	12	15	11	61	13	15	12	62		
		106A	6.0	7.2	21	25	19	68	22	25	20	69		
		108A	11.5	13.8	29	30	27	75	30	30	28	76		
		109A	14.0	16.8	33	35	30	78	34	35	31	79		
		108A+108A	23.0	27.7	46	50	43	116	47	50	44	117		
	HIGH	NONE	-	-	13	15	13	79	14	20	14	80		
		106A	6.0	7.2	22	25	21	86	23	25	22	87		
		108A	11.5	13.8	30	30	29	93	31	35	30	94		
		109A	14.0	16.8	34	35	32	96	35	35	33	97		
		108A+108A	23.0	27.7	48	50	45	134	49	50	46	135		
575-3-60	DD-STD	NONE	-	-	11	15	11	39	13	15	13	41		
	MED	NONE	-	-	9	15	8	42	11	15	10	44		
	HIGH	NONE	-	-	10	15	10	57	12	15	12	59		

See Legend and Notes for Table 35 on page 30.



**Table 35 – Unit Wire/Fuse or HACR Breaker Sizing Data (cont)**

UNIT	NO M. V-PH-HZ	IFM TYPE	ELEC. HTR			NO C.O. or UNPWR C.O.							
			CRHEATER***A00	Nom (kW)	FLA	NO P.E.				w/ P.E. (pwrd fr/unit)			
						MCA	MAX FUSE or HACR BRKR	DISC. SIZE		MCA	MAX FUSE or HACR BRKR	DISC. SIZE	
								FLA	LRA			FLA	LRA
RHX060	208/230-1-60	DD-STD	NONE	-	-	39	60	37	163	41	60	40	165
			102A	4.9/6.5	23.5/27.1	68/73	80/80	64/69	187/190	70/75	80/80	67/71	189/192
			103B	6.5/8.7	31.4/36.3	78/84	80/90	73/79	194/199	80/86	80/100	76/81	196/201
			102A+102A	9.8/13.0	46.9/54.2	98/107	100/110	91/100	257/271	99/109	100/110	93/102	259/273
			103B+103B	13.1/17.4	62.8/72.5	117/130	125/150	110/121	289/308	119/131	125/150	112/123	291/310
			104B+104B	15.8/21.0	75.8/87.5	134/148	150/150	125/138	315/338	136/150	150/150	127/140	317/340
	208/230-3-60	DD-STD	NONE	-	-	29	40	28	120	31	45	31	122
			102A	4.9/6.5	13.6/15.6	46/49	50/60	44/46	134/136	48/51	60/60	46/49	136/138
			104B	7.9/10.5	21.9/25.3	57/61	60/70	54/58	142/145	58/63	60/70	56/60	144/147
			105A	12.0/16.0	33.4/38.5	71/77	80/80	67/73	153/159	73/79	80/80	69/75	155/161
			104B+104B	15.8/21.0	43.8/50.5	84/92	90/100	79/86	208/221	86/94	90/100	81/89	210/223
			104B+105A	19.9/26.5	55.2/63.8	98/109	100/110	92/102	230/248	100/111	100/125	94/104	232/250
		MED	NONE	-	-	30/30	45/45	30/29	185	32/32	45/45	32/32	187
			102A	4.9/6.5	13.6/15.6	47/50	50/60	45/47	199/201	49/51	60/60	47/50	201/203
			104B	7.9/10.5	21.9/25.3	58/62	60/70	55/59	207/210	59/64	60/70	57/61	209/212
			105A	12.0/16.0	33.4/38.5	72/78	80/80	68/74	218/224	74/80	80/80	70/76	220/226
			104B+104B	15.8/21.0	43.8/50.5	85/93	90/100	80/88	273/286	87/95	90/100	82/90	275/288
			104B+105A	19.9/26.5	55.2/63.8	99/110	100/110	93/103	295/313	101/112	110/125	95/105	297/315
	HIGH	NONE	-	-	30/30	45/45	30/29	185	32/32	45/45	32/32	187	
		102A	4.9/6.5	13.6/15.6	47/50	50/60	45/47	199/201	49/51	60/60	47/50	201/203	
		104B	7.9/10.5	21.9/25.3	58/62	60/70	55/59	207/210	59/64	60/70	57/61	209/212	
		105A	12.0/16.0	33.4/38.5	72/78	80/80	68/74	218/224	74/80	80/80	70/76	220/226	
		104B+104B	15.8/21.0	43.8/50.5	85/93	90/100	80/88	273/286	87/95	90/100	82/90	275/288	
		104B+105A	19.9/26.5	55.2/63.8	99/110	100/110	93/103	295/313	101/112	110/125	95/105	297/315	
RHX060	460-3-60	DD-STD	NONE	-	-	14	20	14	58	15	20	15	59
			106A	6.0	7.2	23	25	22	65	24	25	23	66
			108A	11.5	13.8	31	35	29	72	32	35	31	73
			109A	14.0	16.8	35	35	33	75	36	40	34	76
			108A+108A	23.0	27.7	49	50	45	113	50	50	47	114
			108A+109A	25.5	30.7	52	60	49	119	53	60	50	120
	MED	NONE	-	-	14	20	14	90	15	20	15	91	
		106A	6.0	7.2	23	25	22	97	24	25	23	98	
		108A	11.5	13.8	31	35	30	104	32	35	31	105	
		109A	14.0	16.8	35	35	33	107	36	40	34	108	
		108A+108A	23.0	27.7	49	50	46	145	50	50	47	146	
		108A+109A	25.5	30.7	53	60	49	151	54	60	50	152	
	HIGH	NONE	-	-	14	20	14	90	15	20	15	91	
		106A	6.0	7.2	23	25	22	97	24	25	23	98	
		108A	11.5	13.8	31	35	30	104	32	35	31	105	
		109A	14.0	16.8	35	35	33	107	36	40	34	108	
		108A+108A	23.0	27.7	49	50	46	145	50	50	47	146	
		108A+109A	25.5	30.7	53	60	49	151	54	60	50	152	
575-3-60	DD-STD	NONE	-	-	12	15	11	46	14	15	14	48	
	MED	NONE	-	-	10	15	10	64	12	15	12	66	
	HIGH	NONE	-	-	10	15	10	64	12	15	12	66	

See "Legend and Notes for Table 35 on page 30.

## SEQUENCE OF OPERATION

### Cooling, unit without economizer

#### Cooling (Single speed indoor fan motor) —

When thermostat calls for cooling, terminals G and Y1 are energized. The indoor fan contactor (IFC), reversing valve solenoid (RVS) and compressor contactor are energized and indoor fan motor, compressor, and outdoor fan starts. The outdoor fan motor runs continuously while unit is cooling.

Two-stage models: If Stage 1 cooling does not satisfy the space load, the space temperature will rise until thermostat calls for Stage 2 cooling (Y2 closes). Defrost Board activates Stage 2 Compressor. Reversing valve 2 switches to Cooling position. Compressor 2 contactor is energized; Compressor 2 starts and Circuit 2 operates in Cooling mode.

When Cooling Stage 2 is satisfied, thermostat Y2 opens. Compressor 2 contactor is de-energized; Compressor 2 stops. Reversing Valve 2 remains energized.

When Cooling Stage 1 is satisfied, thermostat Y1 opens. Compressor 1 contactor is de-energized; Compressor 1 stops. Outdoor fan relay is de-energized; outdoor fans stop. After the Fan Delay period, the Indoor fan contactor is de-energized; indoor fan stops (unless Continuous Fan operation has been selected). Reversing Valve 1 remains energized.

Reversing valve solenoids are energized in Cooling modes. Each solenoid will remain energized until the next Heating mode is initiated for this circuit.

### Heating, unit without economizer

Upon a request for heating from the space thermostat, terminal W1 will be energized with 24V. The IFC, outdoor fan contactor (OFC), C1, and C2 will be energized. The indoor fan, outdoor fans, and compressor no. 1, and compressor no. 2 are energized and reversing valves are de-energized and switch position.

If the space temperature continues to fall while W1 is energized, W2 will be energized with 24V, and the heater contactor(s) (HC) will be energized, which will energize the electric heater(s).

When the space thermostat is satisfied, W2 will be de-energized first, and the electric heater(s) will be de-energized.

Upon a further rise in space temperature, W1 will be de-energized.

Two compressor models: When the thermostat calls for heating, terminal W1 is energized. Defrost Board de-energizes both reversing valve solenoids and reversing valves move to Heating position. The indoor fan contactor is energized; indoor fan motor starts. Outdoor fan relay is energized; both outdoor fan

motors run. Compressor contactors C1 and C2 are energized; both refrigeration circuits operate in Heating mode.

If Stage 1 heating does not satisfy the space load, the space temperature will fall until thermostat calls for Stage 2 heating (W2 closes). Terminal W2 is energized. Defrost Board issues an output at EHEAT. Heater contactor 1 and heater contactor 2 (if installed) are energized; all electric heaters are energized.

When space heating load is partially satisfied, thermostat terminal W2 is de-energized; heater contactors are de-energized and all electric heat is terminated. Stage 1 heating continues.

When the space heating load is fully satisfied, thermostat terminal W1 is also de-energized.

Reversing valve solenoids remain de-energized until the next call for Cooling mode is initiated.

### Cooling, unit with EconoMi\$er IV

When free cooling is not available, the compressors will be controlled by the zone thermostat. When free cooling is available, the outdoor air damper is modulated by the EconoMi\$er IV control to provide a 50 to 55°F (10° to 13°C) mixed air temperature into the zone. As the mixed air temperature fluctuates above 55 or below 50°F (13° to 10°C), the dampers will be modulated (open or close) to bring the mixed air temperature back within control.

If mechanical cooling is utilized with free cooling, the outdoor air damper will maintain its current position at the time the compressor is started. If the increase in cooling capacity causes the mixed air temperature to drop below 45°F (7°C), then the outdoor air damper position will be decreased to the minimum position. If the mixed air temperature continues to fall, the outdoor air damper will close. Control returns to normal once the mixed air temperature rises above 48°F (9°C).

If optional power exhaust is installed, as the outdoor air damper opens and closes, the power exhaust fans will be energized and de-energized.

If field-installed accessory CO<sub>2</sub> sensors are connected to the EconoMi\$er IV control, a demand controlled ventilation strategy will begin to operate. As the CO<sub>2</sub> level in the zone increases above the CO<sub>2</sub> setpoint, the minimum position of the damper will be increased proportionally. As the CO<sub>2</sub> level decreases because of the increase in fresh air, the outdoor air damper will be proportionally closed.

For EconoMi\$er IV operation, there must be a thermostat call for the fan (G). If the unit is occupied and the fan is on, the damper will operate at minimum position. Otherwise, the damper will be closed.

## SEQUENCE OF OPERATION (cont.)

When the EconoMi\$er IV control is in the occupied mode and a call for cooling exists (Y1 on the thermostat), the control will first check for indoor fan operation. If the fan is not on, then cooling will not be activated. If the fan is on, then the control will open the EconoMi\$er IV damper to the minimum position.

On the initial power to the EconoMi\$er IV control, it will take the damper up to  $2\frac{1}{2}$  minutes before it begins to position itself. Any change in damper position will take up to 30 seconds to initiate. Damper movement from full closed to full open (or vice versa) will take between  $1\frac{1}{2}$  and  $2\frac{1}{2}$  minutes.

If free cooling can be used as determined from the appropriate changeover command (switch, dry bulb, enthalpy curve, differential dry bulb, or differential enthalpy), then the control will modulate the dampers open to maintain the mixed air temperature setpoint at 50° to 55°F (10° to 13°C).

If there is a further demand for cooling (cooling second stage — Y2 is energized), then the control will bring on compressor stage 1 to maintain the mixed air temperature setpoint. The EconoMi\$er IV damper will be open at maximum position. EconoMi\$er IV operation is limited to a single compressor.

### Heating, unit with EconoMi\$er

When the room temperature calls for heat through terminal W1, the indoor (evaporator) fan contactor (IFC) and heater contactor no. 1 (HC1) are energized and the reversing valve(s) de-energize and switches position. On units equipped for 2 stages of heat, when additional heat is needed, heater contactor no. 2 is energized through W2. The economizer damper moves to the minimum position. When the thermostat is satisfied, the damper moves to the fully closed position.

### Defrost

When the temperature of the outdoor coil drops below 28°F (-2°C) as sensed by the defrost thermostat (DFT2) and the defrost timer is at the end of a timed period (adjustable at 30, 60, 90 or 120 minutes), reversing valve solenoids (RVS1 and RVS2) are energized and the OFC is de-energized. This switches the position of the reversing valves and shuts off the outdoor fan. The electric heaters (if installed) will be energized.

The unit continues to defrost until the coil temperature as measured by DFT2 reaches 65°F (18°C), or the duration of defrost cycle completes a 10-minute period.

During the Defrost mode, if circuit 1 defrosts first, RVS1 will oscillate between Heating and Cooling modes until the Defrost mode is complete.

At the end of the defrost cycle, the electric heaters (if installed) will be de-energized; the reversing valves switch and the outdoor fan motor will be energized. The unit will now operate in the Heating mode.

If the space thermostat is satisfied during a defrost cycle, the unit will continue in the Defrost mode until the time or temperature constraints are satisfied.

### Automatic changeover

When the system selection switch is set at AUTO position, unit automatically changes from heating operation to cooling operation when the temperature of the conditioned space rises to the cooling level setting. When the temperature of the conditioned space falls to the heating level setting, unit automatically changes from cooling to heating operation (with a 3°F deadband in between).

### Continuous air circulation

Turn unit power on. Set system control at OFF position. Set fan switch at ON position. The indoor fan contactor is energized through the thermostat switch and the indoor fan runs continuously.

### Emergency heat

When the switch is on (thermostat is set to the EM HT position), compressor circuit and outdoor thermostats are bypassed, and the second stage of thermostat energizes the indoor blower and the electric resistance heaters.

# GUIDE SPECIFICATIONS – RHX036 – 60

Note about this specification:

ICP created this specification in “Masterformat” as published by the Construction Specification Institute. Please feel free to copy this specification directly into your building specifications.

## Rooftop Packaged Heat Pump

### HVAC Guide Specifications

**Size Range:** 3 to 5 Nominal  
**Tons**

**Section Description**

#### **23 06 80 Schedules for Decentralized HVAC Equipment**

23 06 80.13 Decentralized Unitary HVAC Equipment Schedule

23 06 80.13.A. Rooftop unit schedule

1. Schedule is per the project specification requirements.

#### **23 07 16 HVAC Equipment Insulation**

23 07 16.13 Decentralized, Rooftop Units:

23 07 16.13.A. Evaporator fan compartment:

1. Interior cabinet surfaces shall be insulated with a minimum 1/2-in. thick, minimum 1 1/2 lb density, flexible fiberglass insulation bonded with a phenolic binder, neoprene coated on the air side.
2. Insulation and adhesive shall meet NFPA 90A requirements for flame spread and smoke generation.

23 07 16.13.B. Electric heat compartment:

1. Aluminum foil-faced fiberglass insulation shall be used.
2. Insulation and adhesive shall meet NFPA 90A requirements for flame spread and smoke generation.

#### **23 09 13 Instrumentation and Control Devices for HVAC**

23 09 13.23 Sensors and Transmitters

23 09 13.23.A. Thermostats

1. Thermostat must
  - a. have capability to energize 2 different stages of cooling, and 2 different stages of heating.
  - b. include capability for occupancy scheduling.

#### **23 09 33 Electric and Electronic Control System for HVAC**

23 09 33.13 Decentralized, Rooftop Units:

23 09 33.13.A. General:

1. Shall be complete with self-contained low voltage control circuit protected by a resettable circuit breaker on the 24-v transformer side. Transformer shall have 75VA capability.
2. Shall utilize color-coded wiring.
3. Shall include a central control terminal board to conveniently and safely provide connection points for vital control functions such as: smoke detectors, phase monitor, economizer, thermostat, DDC control options, loss of charge, freeze switch, high pressure switches.
4. Unit shall include a minimum of one 8-pin screw terminal connection board for connection of control wiring.
5. Shall include integrated defrost system to prevent excessive frost accumulation during heating duty, and shall be controlled as follows:
  - a. Defrost shall be initiated on the basis of time and coil temperature.
  - b. A 30,60,90,120 minute timer shall activate the defrost cycle only if the coil temperature is low enough to indicate a heavy frost condition.
  - c. Defrost cycle shall terminate when defrost thermostat is satisfied and shall have a positive termination time of 10 minutes.
6. Defrost system shall also include:
  - a. Defrost Cycle Indicator LED.
  - b. Dip switch selectable defrost time between 30,60,90 and 120 minutes. Factory set at 30 minutes.
  - c. Molded plug connection to insure proper connection.

23 09 33.23.B. Safeties:

1. Compressor overtemperature, overcurrent.
2. Loss of charge switch.
  - a. Loss of charge switch shall use different color wire than the high pressure switch. The purpose is to assist the installer and service technician to correctly wire and or troubleshoot the rooftop unit.
3. High pressure switch.
  - a. High pressure switch shall use different color wire than the low pressure switch. The purpose is to assist the installer and service technician to correctly wire and or troubleshoot the rooftop unit.
4. Freeze protection thermostat, evaporator coil.
5. Automatic reset, motor thermal overload protector.

**23 09 93 Sequence of Operations for HVAC Controls**

23 09 93.13 Decentralized, Rooftop Units:

23 09 93.13 INSERT SEQUENCE OF OPERATION

**23 40 13 Panel Air Filters**

23 40 13.13 Decentralized, Rooftop Units:

23 40 13.13.A. Standard filter section

1. Shall consist of factory-installed, low velocity, throwaway 2-in. thick fiberglass filters of commercially available sizes.
2. Unit shall use only one filter size. Multiple sizes are not acceptable.
3. Filters shall be accessible through an access panel with “no-tool” removal as described in the unit cabinet section of this specification (23 81 19.13.G).

**23 81 19 Self-Contained Air Conditioners**

23 81 19.13 Small-Capacity Self-Contained Air Conditioners (RHX036-60)

23 81 19.13.A. General

1. Outdoor, rooftop mounted, electrically controlled, heating and cooling unit utilizing a(n) hermetic scroll compressor(s) for cooling duty and heat pump for heating duty.
2. Factory assembled, single piece heating and cooling rooftop unit. Contained within the unit enclosure shall be all factory wiring, piping, controls, and special features required prior to field startup.
3. Unit shall use R-410A refrigerant.
4. Unit shall be installed in accordance with the manufacturer’s instructions.
5. Unit must be selected and installed in compliance with local, state, and federal codes.

23 81 19.13.B. Quality Assurance

1. Unit meets ASHRAE 90.1 minimum efficiency requirements.
2. Unit shall be rated in accordance with AHRI Standards 210/240.
3. Unit shall be designed to conform to ASHRAE 15.
4. Unit shall be UL-tested and certified in accordance with ANSI Z21.47 Standards and UL-listed and certified under Canadian standards as a total package for safety requirements.
5. Insulation and adhesive shall meet NFPA 90A requirements for flame spread and smoke generation.
6. Unit casing shall be capable of withstanding 500-hour salt spray exposure per ASTM B117 (scribed specimen).
7. Unit shall be designed in accordance with ISO 9001, and shall be manufactured in a facility registered by ISO 9001.
8. Roof curb shall be designed to conform to NRCA Standards.
9. Unit shall be subjected to a completely automated run test on the assembly line. The data for each unit will be stored at the factory, and must be available upon request.
10. Unit shall be designed in accordance with UL Standard 1995, including tested to withstand rain.
11. Unit shall be constructed to prevent intrusion of snow and tested to prevent snow intrusion into the control box up to 40 mph.
12. Unit shake tested to assurance level 1, ASTM D4169 to ensure shipping reliability.

23 81 19.13.C. Delivery, Storage, and Handling

1. Unit shall be stored and handled per manufacturer’s recommendations.
2. Lifted by crane requires either shipping top panel or spreader bars.
3. Unit shall only be stored or positioned in the upright position.

23 81 19.13.D. Project Conditions

1. As specified in the contract.

23 81 19.13.E. Operating Characteristics

1. Unit shall be capable of starting and running at 115°F (46°C) ambient outdoor temperature, meeting maximum load criteria of AHRI Standard 210/240 at ± 10% voltage.
2. Compressor with standard controls shall be capable of operation from 25°F (-4°C), ambient outdoor temperatures. Accessory winter start kit is necessary if mechanically cooling at ambient temperatures below 25°F (-4°C).
3. Unit shall be capable of simultaneous heating duty and defrost cycle operation when using accessory electric heaters.
4. Unit shall discharge supply air vertically or horizontally as shown on contract drawings.
5. Unit shall be factory configured for vertical supply & return configurations.
6. Unit shall be field convertible from vertical to horizontal configuration
7. Unit shall be capable of mixed operation: vertical supply with horizontal return or horizontal supply with vertical return.

23 81 19.13.F. Electrical Requirements

1. Main power supply voltage, phase, and frequency must match those required by the manufacturer.

23 81 19.13.G. Unit Cabinet

1. Unit cabinet shall be constructed of galvanized steel, and shall be bonderized and coated with a pre-painted baked enamel finish on all externally exposed surfaces.
2. Unit cabinet exterior paint shall be: film thickness, (dry) 0.003 inches minimum, gloss (per ASTM D523, 60°F): 60, Hardness: H-2H Pencil hardness.
3. Evaporator fan compartment interior cabinet insulation shall conform to AHRI Standards 210/240 minimum exterior sweat criteria. Interior surfaces shall be insulated with a minimum 1/2-in. thick, 1 lb density, flexible fiberglass insulation, neoprene coated on the air side. Aluminum foil-faced fiberglass insulation shall be used in the heat compartment.
4. Base of unit shall have a minimum of three locations for thru-the-base electrical connections (factory-installed or field-installed), standard.
5. Base Rail
  - a. Unit shall have base rails on a minimum of 2 sides.
  - b. Holes shall be provided in the base rails for rigging shackles to facilitate maneuvering and overhead rigging.
  - c. Holes shall be provided in the base rail for moving the rooftop by fork truck.
  - d. Base rail shall be a minimum of 16 gauge thickness.
6. Condensate pan and connections:
  - a. Shall be a sloped condensate drain pan made of a non-corrosive material.
  - b. Shall comply with ASHRAE Standard 62.
  - c. Shall use a 3/4-in. -14 NPT drain connection, possible either through the bottom or end of the drain pan. Connection shall be made per manufacturer's recommendations.
7. Top panel:
  - a. Shall be a single piece top panel on all sizes.
8. Electrical Connections
  - a. All unit power wiring shall enter unit cabinet at a single, factory prepared, knockout location.
  - b. Thru-the-base capability.
    - (1.) Standard unit shall have a thru-the-base electrical location (s) using a raised, embossed portion of the unit basepan.
    - (2.) Optional, factory-approved, water-tight connection method must be used for thru-the-base electrical connections.
    - (3.) No basepan penetration, other than those authorized by the manufacturer, is permitted.
9. Component access panels (standard)
  - a. Cabinet panels shall be easily removable for servicing.
  - b. Unit shall have one factory-installed, tool-less, removable, filter access panel.
  - c. Panels covering control box, indoor fan, indoor fan motor, gas components (where applicable), and compressors shall have molded composite handles.
  - d. Handles shall be UV modified, composite. permanently attached, and recessed into the panel.

- e. Screws on the vertical portion of all removable access panel shall engage into heat resistant, molded composite collars.
- f. Collars shall be removable and easily replaceable using manufacturer recommended parts.

23 81 19.13.H. Coils

1. Standard Aluminum/Copper Coils: on all models.
  - a. Standard evaporator and condenser coils shall have aluminum lanced plate fins mechanically bonded to seamless internally grooved copper tubes with all joints brazed.
  - b. Evaporator coils shall be leak tested to 150 psig, pressure tested to 450 psig, and qualified to UL 1995 burst test at 1775 psig.
  - c. Condenser coils shall be leak tested to 150 psig, pressure tested to 650 psig, and qualified to UL 1995 burst test at 1980 psig.
2. Optional Pre-coated aluminum fin condenser coils: on all models.
  - a. Shall have a durable epoxy-phenolic coating to provide protection in mildly corrosive coastal environments.
  - b. Coating shall be applied to the aluminum fin stock prior to the fin stamping process to create an inert barrier between the aluminum fin and copper tube.
  - c. Epoxy-phenolic barrier shall minimize galvanic action between dissimilar metals.
3. Optional Copper-fin evaporator and condenser coils: on all models.
  - a. Shall be constructed of copper fins mechanically bonded to copper tubes and copper tube sheets.
  - b. Galvanized steel tube sheets shall not be acceptable.
  - c. A polymer strip shall prevent coil assembly from contacting the sheet metal coil pan to minimize potential for galvanic corrosion between coil and pan.
4. Optional E-coated aluminum-fin evaporator and condenser coils: (3 Phase Models Only):
  - a. Shall have a flexible epoxy polymer coating uniformly applied to all coil surface areas without material bridging between fins.
  - b. Coating process shall ensure complete coil encapsulation of tubes, fins and headers.
  - c. Color shall be high gloss black with gloss per ASTM D523-89.
  - d. Uniform dry film thickness from 0.8 to 1.2 mil on all surface areas including fin edges.
  - e. Superior hardness characteristics of 2H per ASTM D3363-92A and cross-hatch adhesion of 4B-5B per ASTM D3359-93.
  - f. Impact resistance shall be up to 160 in.-lb (ASTM D2794-93).
  - g. Humidity and water immersion resistance shall be up to minimum 1000 and 250 hours respectively (ASTM D2247-92 and ASTM D870-92).
  - h. Corrosion durability shall be confirmed through testing to be no less than 1000 hours salt spray per ASTM B117-90.

23 81 19.13.I. Refrigerant Components

1. Refrigerant circuit shall include the following control, safety, and maintenance features:
  - a. Fixed orifice metering system shall prevent mal-distribution of two-phase refrigerant by including multiple fixed orifice devices in each refrigeration circuit. Each orifice is to be optimized to the coil circuit it serves.
  - b. Refrigerant filter drier.
  - c. Service gauge connections on suction and discharge lines.
  - d. Pressure gauge access through a specially designed access port in the top panel of the unit.
  - e. Suction line accumulator to provide protection in all operating modes from cooling, heating and reverse cycle switching.
2. There shall be gauge line access port in the top of the rooftop, covered by a black, removable plug.
  - a. The plug shall be easy to remove and replace.
  - b. When the plug is removed, the gauge access port shall enable maintenance personnel to route their pressure gauge lines.
  - c. This gauge access port shall facilitate correct and accurate condenser pressure readings by enabling the reading with the compressor access panel on.
  - d. The plug shall be made of a leak proof, UV-resistant, composite material.
3. Compressors
  - a. Unit shall use one fully hermetic, scroll compressor for each independent refrigeration circuit.
  - b. Models shall be available with single compressor designs.

- c. Compressor motors shall be cooled by refrigerant gas passing through motor windings.
- d. Compressors shall be internally protected from high discharge temperature conditions.
- e. Compressors shall be protected from an overtemperature and over-ampereage conditions by an internal, motor overload device.
- f. Compressor shall be factory mounted on rubber grommets.
- g. Compressor motors shall have internal line break thermal, current overload and high pressure differential protection.
- h. Crankcase heaters shall not be required for normal operating range, unless provided by compressor manufacturer due to refrigerant charge limits.

23 81 19.13.J. Filter Section

- 1. Filters access is specified in the unit cabinet section of this specification.
- 2. Filters shall be held in place by a pivoting filter tray, facilitating easy removal and installation.
- 3. Shall consist of factory-installed, low velocity, throw-away 2-in. thick fiberglass filters.
- 4. Filters shall be standard, commercially available sizes.
- 5. Only one size filter per unit is allowed.

23 81 19.13.K. Evaporator Fan and Motor

- 1. Evaporator fan motor:
  - a. Shall have permanently lubricated bearings.
  - b. Shall have inherent automatic-reset thermal overload protection or circuit breaker.
  - c. Shall have a maximum continuous bhp rating for continuous duty operation; no safety factors above that rating shall be required.
- 2. Direct Drive – ECM Evaporator Fan Standard:
  - a. Multi speed motor with easy quick adjustment settings.
  - b. Blower fan shall be double inlet type with forward curved blades.
  - c. Shall be constructed from steel with a corrosion resistant finish and dynamically balanced.
  - d. Standard on all 04–06 models.
- 3. Belt-driven Evaporator Fan Optional:
  - a. Belt drive shall include an adjustable pitch motor pulley.
  - b. Shall use sealed, permanently lubricated ball-bearing type.
  - c. Blower fan shall be double inlet type with forward curved blades.
  - d. Shall be constructed from steel with a corrosion resistant finish and dynamically balanced.

23 81 19.13.L. Condenser Fans and Motors

- 1. Condenser fan motors:
  - a. Shall be a totally enclosed motor.
  - b. Shall use permanently lubricated bearings.
  - c. Shall have inherent thermal overload protection with an automatic reset feature.
  - d. Shall use a shaft down design on all sizes.
- 2. Condenser Fans:
  - a. Shall be a direct driven propeller type fan.
  - b. Shall have galvalum blades riveted to corrosion resistant steel spiders and shall be dynamically balanced.

23 81 19.13.M. Special Features, Options and Accessories

- 1. Integrated EconoMi\$er IV and EconoMi\$er X standard leak rate models. (Factory installed on 3 phase models only. Field installed on all 3 and 1 phase models)
  - a. Integrated, gear driven opposing modulating blade design type capable of simultaneous economizer and compressor operation.
  - b. Independent modules for vertical or horizontal return configuration shall be available. Vertical return modules shall be available as a factory installed option.
  - c. Damper blades shall be galvanized steel with composite gears. Plastic or composite blades on intake or return shall not be acceptable.
  - d. Shall include all hardware and controls to provide free cooling with outdoor air when temperature and/or humidity are below setpoints.
  - e. Shall be equipped with gear driven dampers for both the outdoor ventilation air and the return air for positive air stream control.



- f. Standard leak rate shall be equipped with dampers not to exceed 2% leakage at 1 in. wg pressure differential.
- g. Economizer controller on EconoMi\$er IV models shall be Honeywell W7212 that provides:
  - (1.) Combined minimum and DCV maximum damper position potentiometers with compressor staging relay.
  - (2.) Functions with solid state analog enthalpy or dry bulb changeover control sensing.
  - (3.) Contain LED indicates for:
    - when free cooling is available, when module is in DCV mode, when exhaust fan contact is closed.
- h. Economizer controller on EconoMi\$er X models shall be the Honeywell W7220 that provides:
  - (1.) 2–line LCD interface screen for setup, configuration and troubleshooting.
  - (2.) On–board Fault Detection and Diagnostics (FDD) that senses and alerts when the economizer is not operating properly, per California Title 24.
  - (3.) Sensor failure loss of communication identification
  - (4.) Automatic sensor detection
  - (5.) Capabilities for use with multiple–speed indoor fan systems
  - (6.) Utilize digital sensors: Dry bulb and Enthalpy
- i. Shall be capable of introducing up to 100% outdoor air.
- j. Shall be equipped with a barometric relief damper capable of relieving up to 100% return air and contain seals that meet ASHRAE 90.1 requirements.
- k. Shall be designed to close damper(s) during loss–of–power situations with spring return built into motor.
- l. Dry bulb outdoor air temperature sensor shall be provided as standard. Enthalpy sensor is also available on factory installed only. Outdoor air sensor setpoint shall be adjustable and shall range from 40 to 100°F /4 to 38°C. Additional sensor options shall be available as accessories.
- m. The economizer controller shall also provide control of an accessory power exhaust unit function. Factory set at 100%, with a range of 0% to 100%.
- n. The economizer shall maintain minimum airflow into the building during occupied period and provide design ventilation rate for full occupancy.
- o. Dampers shall be completely closed when the unit is in the unoccupied mode.
- p. Economizer controller shall accept a 2–10 Vdc CO<sub>2</sub> sensor input for IAQ/DCV control. In this mode, dampers shall modulate the outdoor air damper to provide ventilation based on the sensor input.
- q. Compressor lockout temperature on W7220 is adjustable from –45°F to 80°F, set at a factory default of 32°F. Others shall open at 35°F (2°C) and closes at 50°F (10°C).
- r. Actuator shall be direct coupled to economizer gear. No linkage arms or control rods shall be acceptable.
- s. Economizer controller shall provide indications when in free cooling mode, in the DCV mode, or the exhaust fan contact is closed.
- 2. Integrated EconoMi\$er X Ultra Low Leak rate models.(Factory installed on 3 phase models only. Field installed on all 3 and 1 phase models)
  - a. Integrated, gear driven opposing modulating blade design type capable of simultaneous economizer and compressor operation.
  - b. Independent modules for vertical or horizontal return configuration shall be available. Vertical return modules shall be available as a factory installed option.
  - c. Damper blades shall be galvanized steel with composite gears. Plastic or composite blades on intake or return shall not be acceptable.
  - d. Shall include all hardware and controls to provide free cooling with outdoor air when temperature and/or humidity are below setpoints.
  - e. Shall be equipped with gear driven dampers for both the outdoor ventilation air and the return air for positive air stream control
  - f. Ultra Low Leak design meets California Title 24 section 140.4 and ASHRAE 90.1 requirements for 4 cfm per sq.ft. on the outside air dampers and 10 cfm per sq. ft. on the return dampers.
  - g. Economizer controller on EconoMi\$er X models shall be the Honeywell W7220 that provides:
    - (1.) 2–line LCD interface screen for setup, configuration and troubleshooting
    - (2.) On–board Fault Detection and Diagnostics (FDD) that senses and alerts when the economizer is not operating properly, per California Title 24.

- (3.) Sensor failure loss of communication identification
  - (4.) Automatic sensor detection
  - (5.) Capabilities for use with multiple-speed indoor fan systems
  - (6.) Utilize digital sensors: Dry bulb and Enthalpy
  - h. Shall be capable of introducing up to 100% outdoor air.
  - i. Shall be equipped with a barometric relief damper capable of relieving up to 100% return air and contain seals that meet ASHRAE 90.1 requirements.
  - j. Shall be designed to close damper(s) during loss-of-power situations with spring return built into motor.
  - k. Dry bulb outdoor air temperature sensor shall be provided as standard. Enthalpy sensor is also available on factory installed only. Outdoor air sensor setpoint shall be adjustable and shall range from 40 to 100° F / 4 to 38° C. Additional sensor options shall be available as accessories.
  - l. The economizer controller shall also provide control of an accessory power exhaust unit function. Factory set at 100%, with a range of 0% to 100%.
  - m. The economizer shall maintain minimum airflow into the building during occupied period and provide design ventilation rate for full occupancy.
  - n. Dampers shall be completely closed when the unit is in the unoccupied mode.
  - o. Economizer controller shall accept a 2–10 Vdc CO<sub>2</sub> sensor input for IAQ/DCV control. In this mode, dampers shall modulate the outdoor air damper to provide ventilation based on the sensor input.
  - p. Compressor lockout temperature on W7220 is adjustable from –45° F to 80° F, set at a factory default of 32° F. Others shall open at 35°F (2°C) and closes at 50°F (10°C).
  - q. Actuator shall be direct coupled to economizer gear. No linkage arms or control rods shall be acceptable.
  - r. Economizer controller shall provide indications when in free cooling mode, in the DCV mode, or the exhaust fan contact is closed.
3. Two-Position Damper (Factory installed on 3 Phase Models Only. Field installed on all 3 and 1 Phase Models)
- a. Damper shall be a Two-Position Damper. Damper travel shall be from the full closed position to the field adjustable %-open setpoint.
  - b. Damper shall include adjustable damper travel from 25% to 100% (full open).
  - c. Damper shall include single or dual blade, gear driven dampers and actuator motor.
  - d. Actuator shall be direct coupled to damper gear. No linkage arms or control rods shall be acceptable.
  - e. Damper will admit up to 100% outdoor air for applicable rooftop units.
  - f. Damper shall close upon indoor (evaporator) fan shutoff and/or loss of power.
  - g. The damper actuator shall plug into the rooftop unit's wiring harness plug. No hard wiring shall be required.
  - h. Outside air hood shall include aluminum water entrainment filter
4. Head Pressure Control Package
- a. Controller shall control coil head pressure by condenser fan speed modulation or condenser fan cycling and wind baffles.
  - b. Shall consist of solid state control and condenser coil temperature sensor to maintain condensing temperature between 90° F (32° C) and 110° F (43° C) at outdoor ambient temperatures down to –20° F (–29° C).
5. Condenser Coil Hail Guard Assembly (Factory installed on 3 Phase Models Only. Field installed on all 3 and 1 Phase Models)
- a. Shall protect against damage from hail.
  - b. Shall be louvered design.
6. Unit Mounted, Non-Fused Disconnect Switch:
- a. Switch shall be factory-installed, internally mounted.
  - b. National Electric Code (NEC) and UL approved non-fused switch shall provide unit power shutoff.
  - c. Shall be accessible from outside the unit
  - d. Shall provide local shutdown and lockout capability.
7. Convenience Outlet:
- a. Non-Powered convenience outlet.
    - (1.) Outlet shall be powered from a separate 115–120v power source.

- (2.) A transformer shall not be included.
  - (3.) Outlet shall be factory-installed and internally mounted with easily accessible 115-v female receptacle.
  - (4.) Outlet shall include 15 amp GFI receptacles.
  - (5.) Outlet shall be accessible from outside the unit.
8. Thru-the-Base Connectors:
    - a. Kits shall provide connectors to permit electrical connections to be brought to the unit through the unit basepan.
    - b. Minimum of three connection locations per unit.
  9. Propeller Power Exhaust:
    - a. Power exhaust shall be used in conjunction with an integrated economizer.
    - b. Independent modules for vertical or horizontal return configurations shall be available.
    - c. Horizontal power exhaust shall be mounted in return ductwork.
    - d. Power exhaust shall be controlled by economizer controller operation. Exhaust fans shall be energized when dampers open past the 0-100% adjustable setpoint on the economizer control.
  10. Roof Curbs (Vertical):
    - a. Full perimeter roof curb with exhaust capability providing separate air streams for energy recovery from the exhaust air without supply air contamination.
    - b. Formed galvanized steel with wood nailer strip and shall be capable of supporting entire unit weight.
    - c. Permits installation and securing of ductwork to curb prior to mounting unit on the curb.
  11. High Static Indoor Fan Motor(s) and Drive(s) (04-06):
    - a. High static motor(s) and drive(s) shall be factory-installed to provide additional performance range.
  12. Thru-the-Bottom Utility Connectors:
    - a. Kit shall provide connectors to permit gas and electrical connections to be brought to the unit through the basepan.
  13. Outdoor Air Enthalpy Sensor:
    - a. The outdoor air enthalpy sensor shall be used to provide single enthalpy control. When used in conjunction with a return air enthalpy sensor, the unit will provide differential enthalpy control. The sensor allows the unit to determine if outside air is suitable for free cooling.
  14. Return Air Enthalpy Sensor:
    - a. The return air enthalpy sensor shall be used in conjunction with an outdoor air enthalpy sensor to provide differential enthalpy control.
  15. Indoor Air Quality (CO<sub>2</sub>) Sensor:
    - a. Shall be able to provide demand ventilation indoor air quality (IAQ) control.
    - b. The IAQ sensor shall be available in duct mount, wall mount, or wall mount with LED display. The setpoint shall have adjustment capability.
  16. Smoke detectors (Factory-Installed Only):
    - a. Shall be a Four-Wire Controller and Detector.
    - b. Shall be environmental compensated with differential sensing for reliable, stable, and drift-free sensitivity.
    - c. Shall use magnet activated test/reset sensor switches.
    - d. Shall have tool-less connection terminal access.
    - e. Shall have a recessed momentary switch for testing and resetting the detector.
    - f. Controller shall include:
      - (1.) One set of normally open alarm initiation contacts for connection to an initiating device circuit on a fire alarm control panel.
      - (2.) Two Form-C auxiliary alarm relays for interface with rooftop unit or other equipment.
      - (3.) One Form-C supervision (trouble) relay to control the operation of the Trouble LED on a remote test/reset station.
      - (4.) Capable of direct connection to two individual detector modules.
      - (5.) Can be wired to up to 14 other duct smoke detectors for multiple fan shutdown applications.
  17. Time Guard
    - a. Shall prevent compressor short cycling by providing a 5-minute delay (±2 minutes) before restarting a compressor after shutdown for any reason.

- b. One device shall be required per compressor.
18. Electric Heat:
- a. Heating Section
    - (1.) Heater element open coil resistance wire, nickel–chrome alloy, 0.29 inches inside diameter, strung through ceramic insulators mounted on metal frame. Coil ends are staked and welded to terminal screw slots.
    - (2.) Heater assemblies are provided with integral fusing for protection of internal heater circuits not exceeding 48 amps each. Auto reset thermo limit controls, magnetic heater contactors (24V coil) and terminal block all mounted in electric heater control box (minimum 18 ga galvanized steel) attached to end of heater assembly.
19. Hinged Access Panels
- a. Shall provide easy access through integrated quarter turn latches.
  - b. Shall be on major panels of: filters, control box, fan motor and compressor.

## ACCESSORIES – RHX036–60

<b>ECONOMIZERS</b>			
<b>ECONOMISER IV (FOR 1-SPEED INDOOR FAN MOTOR ONLY) – STANDARD LEAK CONTROLLER INCLUDED</b>			
<b>VERTICAL</b>			
Model Number	Description	Use With Model Size	Approx Ship Wt. LBS (KGS)
CRECOMZR020A02	STANDARD LEAK Vertical EconoMi\$er IV with solid-state controller, gear-driven, damper, spring return actuator, up to 100% barometric relief, supply and outdoor air temperature sensors, and CO2 sensor compatible, for use in non-DDC applications.	036-060 Elect Mech Controls	55 (25)

<sup>1</sup> EconoMi\$er IV cannot be installed with an EconoMi\$er X, Manual Damper, or Motorized Damper.

<sup>2</sup> When installed on a unit with hinged panels, hinged panel access kit is also required.

<b>HORIZONTAL</b>			
Model Number	Description	Use With Model Size	Approx Ship Wt. LBS (KGS)
CRECOMZR024A02	STANDARD LEAK Horizontal EconoMi\$er IV with solid-state controller, gear-driven, modulating damper, spring return actuator, up to 100% barometric relief, supply and outdoor air temperature sensors, and CO2 sensor compatible, for use in non-DDC applications.	036-060 Elect Mech Controls	85 (39)

<sup>1</sup> EconoMi\$er IV cannot be installed with an EconoMi\$er X, Manual Damper, or Motorized Damper.

<sup>2</sup> When installed on a unit with hinged panels, hinged panel access kit is also required.

<b>ECONOMIZER X (FOR 1 &amp; 2-SPEED INDOOR FAN MOTOR) – STANDARD LEAK, CONTROLLER INCLUDED</b>			
<b>VERTICAL</b>			
Model Number	Description	Use With Model Size	Approx Ship Wt. LBS (KGS)
CRECOMZR076A00	STANDARD LEAK - Vertical EconoMi\$er X with solid-state W7220 controller, gear-driven, modulating damper, spring return actuator, up to 100% barometric relief, supply and outdoor air temperature sensors, and CO2 sensor compatible, for use in electro mechanical controls only. Controller meets California Title 24 Section 120.2 Fault Detection and Diagnostic (FDD) requirements.	036-060 Elect Mech Controls	105 (48)

<sup>1</sup> EconoMi\$er X cannot be installed with an EconoMi\$er IV, Manual Damper or Motorized Damper.

<sup>2</sup> When installed on a unit with hinged panels, hinged panel access kit is also required.

<b>HORIZONTAL</b>			
Model Number	Description	Use With Model Size	Approx Ship Wt. LBS (KGS)
CRECOMZR077A00	STANDARD LEAK - Horizontal EconoMi\$er X with solid-state W7220 controller, gear-driven, modulating damper, spring return actuator, up to 100% barometric relief, supply and outdoor air temperature sensors, and CO2 sensor compatible, for use in electro mechanical controls only. Controller meets California title 24 Section 120.2 Fault Detection and Diagnostic (FDD) requirements.	036-060 Elect Mech Controls	105 (48)

<sup>1</sup> EconoMi\$er X cannot be installed with an EconoMi\$er IV, Manual Damper or Motorized Damper.

<sup>2</sup> When installed on a unit with hinged panels, 3 hinged panel access kit is also required.

<b>ECONOMISER X (FOR 1 &amp; 2-SPEED INDOOR FAN MOTOR) – ULTRA LOW LEAK, CONTROLLER INCLUDED</b>			
<b>VERTICAL</b>			
Model Number	Description	Use With Model Size	Approx Ship Wt. LBS (KGS)
CRECOMZR067A00	Ultra LOW LEAK - Vertical EconoMi\$er X with solid-state W7220 controller, gear-driven, modulating damper, spring return actuator, up to 100% barometric relief, supply and outdoor air temperature sensors, and CO2 sensor compatible, for use in electro mechanical controls only. Also includes return, outside air, and relief air damper leakage that meets Title 24 section 140.4 and ASHRAE 90.1 requirements. Controller meets California Title 24 Fault Detection and Diagnostic (FDD) requirements.	036-060 Elect Mech Controls	105 (48)

<sup>1</sup> EconoMi\$er X cannot be installed with an EconoMi\$er IV, Manual Damper or Motorized Damper.

<sup>2</sup> Currently only available on vertical air flow configuration models. Contact your local MicroMetl account manager 1-800-884-4662 if horizontal model is required.

<sup>3</sup> When installed on a unit with hinged panels, hinged panel access kit is also required.

## ACCESSORIES – RHX036–60 (cont.)

ACCESSORY KITS FOR UNITS WITH HINGED ACCESS PANELS		
VERTICAL		
Model Number	Description	Use With Model Size
CRPECONV003A00	Vertical accessory kit is required when field installing a vertical economizer on a unit that has hinged access panels. Includes angle and seal strip.	036-060
HORIZONTAL		
Model Number	Description	Use With Model Size
CRHNGPNL001A00	Horizontal accessory kit is required when field installing a horizontal economizer on a unit that has hinged access panels. Includes door panel, angle and seal strip.	036-060

ECONOMIZER SENSORS		
Model Number	Description	Use With Model Size
DNTEMPSN002A00	Outdoor or Return Dry Bulb Temperature Sensor used with Electro-Mechanical control.	ECONOMIZER IV
DNCBDIOX005A00	CO <sub>2</sub> Sensor for use in return airstream. Also includes Aspirator Box required for Duct Mounting.	ECONOMIZER IV & X
DNENTDIF004A00	Return Air Enthalpy Sensor used with Electro-Mechanical controls, use with AXB078ENT for differential enthalpy control.	ECONOMIZER IV
AXB078ENT	Accusensor II Economizer Differential Enthalpy Control Upgrade	ECONOMIZER IV
CRTEMPSN005A00	Outdoor or return dry bulb temperature sensor used with Honeywell W7220 electro-mechanical control.	ECONOMIZER X
--HH--57AC-081	Enthalpy control for W7220 controller only. (One required for single enthalpy, two required for differential enthalpy)	ECONOMIZER X

NOTE: Supply air temperature sensor (SAT and low ambient lockout switch) provided with economizer IV or economizer X.

<sup>1</sup> Supply air temperature sensor (SAT and low ambient lockout switch) provided with Economizer IV or Economizer X.

ECONOMIZER SENSOR USAGE CHART			
DESIRED CONTROL METHOD		ECONOMIZER IV <sup>1</sup> REQUIRED FIELD-INSTALLED SENSOR(S)	ECONOMIZER X <sup>1</sup> REQUIRED FIELD-INSTALLED SENSOR(S)
Single Dry Bulb Control		None. Outside Air dry bulb sensor is factory installed.	None. Outside Air dry bulb sensor is factory installed.
Single Enthalpy Control		(1) AXB078ENT	(1) --HH--57AC-081
Differential Dry Bulb		NA	(1) --HH--57AC-081
Differential Enthalpy Control		(1) AXB078ENT & (1) DNENTDIF004A00	(2) --HH--57AC-081
To Add CO <sub>2</sub> DCV Control with above:	Duct Mount	(1) DNCBDIOX005A00	(1) DNCBDIOX005A00

<sup>1</sup> OAT and SAT sensors included for Economizer IV or Economizer X

POWER EXHAUST		
VERTICAL <sup>1, 2</sup>		
Model Number	Description	Use With Model Size
DNPWREXH030A01	Vertical Power Exhaust 208/230 volt (1 or 3 Phase)	036 – 060 208/230–1–60 & 208/230–3–60
DNPWREXH021A01	Vertical Power Exhaust 460 volt	036 – 060 460–3–60

<sup>1</sup> Vertical Power Exhaust requires a vertical Economizer

<sup>2</sup> Vertical Power Exhaust package includes exhaust hood, screens, and propeller fan system

HORIZONTAL <sup>1, 2</sup>		
Model Number	Description	Use With Model Size
DNPWREXH028A01	Horizontal Power Exhaust 208/230 & 575 volt (1 or 3 Phase)	036 – 060 208/230–1–60, 208/230–3–60, 575–3–60
DNPWREXH029A01	Horizontal Power Exhaust 460 volt	036 – 060 460–3–60

<sup>1</sup> Horizontal Power Exhaust should be duct-mounted in the return duct and is supplied with a single fan and wiring harness

<sup>2</sup> Horizontal Power Exhaust package includes exhaust hood, screens, and propeller fan system

## ACCESSORIES – RHX036–60 (cont.)

575V TRANSFORMER		
Model Number	Description	Use With Model Size
1171494 *	Transformer for conversion from 575v to 208/230v power exhaust applications.	ALL

**NOTE:**

- 24" Roof curbs are NOT required with vertical power exhaust.
- Both vertical and horizontal power exhaust packages can be used with either EconoMi\$er IV or EconoMi\$er

X. In either case, the power exhaust is controlled by the EconoMi\$er IV, X controller.

- \* Order --HT--01AH-859, FAST# 1171494, for 575V applications.

MANUAL OUTDOOR AIR DAMPERS		
Model Number	Description	Use With Model Size
CRMANDPR001A03	25% Open Manual Fresh Air Damper	036 – 060
CRMANDPR001A02	50% Open Manual Fresh Air Damper	036 – 060

MOTORIZED OUTDOOR AIR DAMPERS		
Model Number	Description	Use With Model Size
CRTWOPOS010A00	Motorized 2 position outdoor air damper (25–100% Outdoor Air)	036 – 060

**NOTE:** Economizer IV, Economizer X, Manual Damper and 2–Position damper are all mutually exclusive and cannot be installed together.

- Manual dampers include hood assembly, bird screen, adjustable damper blade (to allow up to the rated outdoor air %), and bottom panel with opening.
- Motorized dampers include bottom panel with opening (100% two–position damper includes 30% barometric relief capability), and adjustable damper (to allow up to the rated outdoor air %)
- Motorized dampers will close on loss of power to the rooftop unit.  
Manual and motorized dampers are not compatible with a vertical power exhaust module.

LOUVERED HAIL GUARDS – CONDENSER COIL		
Model Number	Description	Use With Model Size
CRLVHLGD012A00	Louvered Condenser Coil Hail Guard -- Includes louvered panel(s) to protect condenser coil from damage and vandalism.	036
CRLVHLGD013A00	Louvered Condenser Coil Hail Guard -- Includes louvered panel(s) to protect condenser coil from damage and vandalism.	048 – 060

STANDARD ROOF CURBS		
Model Number	Description	Use With Model Size
CRRFCURB001A01	14" (356 mm) High Roof Curb. Ductwork attaches to the roof curb. Includes thru–the–bottom capability.	036 – 060
CRRFCURB002A01	24" (607 mm) High Roof Curb. Ductwork attaches to the roof curb. Includes thru–the–bottom capability.	036 – 060

THRU–THE–BOTTOM/CURB POWER CONNECTION		
Model Number	Description	Use With Model Size
CRBTMPWR001A01	Thru-the-bottom electrical connections and thru-the-curb (not thru the bottom) gas connections. Includes a 3/4-inch (19 mm) diameter liquid tight conduit fitting for high voltage power wires and (2) 1/2-inch (13 mm) diameter liquid tight conduit fittings for thermostat wires and convenience outlet wires. Includes a 3/4-inch (19 mm) inside pipe coupling and gas plate assembly for thru-the-curb connections. Provides for watertight seals.	036-060
CRBTMPWR003A01	Thru-the bottom power, control and gas connections. Includes a 3/4-inch diameter liquid tight conduit fitting for high voltage power wires, (2) 1/2- inch diameter liquid tight conduits for thermostat wires and convenience outlet wires and 1/2-inch gas adapter fitting for gas piping. Provides for watertight seal.	036-060

**NOTE:** Access to the bottom of the RTU is required to install a THRU-THE-BOTTOM Connection Kit. Recommend installing kit prior to installing RTU on roof curb.

## ACCESSORIES – RHX036–60 (cont.)

<b>CONTROL UPGRADE KITS</b>		
<b>Model Number</b>	<b>Description</b>	<b>Use With Model Size</b>
NRTIMEGD001A00	Time Guard II -- Automatically prevents the compressor from restarting for at least 4 minutes and 45 seconds after shutdown of the compressor. Not required when a commercial thermostat has a minimum 5 min time delay between cooling cycles available (One required per unit)	All
DNWINSTR001A00	Winter Start Package - Contains time delay relay for timed bypass of low pressure switch on startup.(One required per refrigerant circuit) <sup>1</sup>	All
CRPHASE3001A02	Phase Monitor Control - Provides phase loss/phase reversal protection	All 3 Phase 208/230-3-60 460-3-60
CRPHASE3002A00	Phase Monitor Control - Provides phase loss/phase reversal protection	All 3 Phase 575v
CRSDTEST001A00	Remote keyed attenuator / test / reset station for use with factory installed smoke detectors. Includes power, alarm & trouble indicator lights.	All

<sup>1</sup> If mechanical cooling below 25 degrees ambient is necessary, consider additional low-ambient control measures (for example, economizer or motormaster)

<b>LOW AMBIENT CONTROLS *</b>		
<b>Model Number</b>	<b>Description</b>	<b>Use With Model Size</b>
CPLOWAMB001A00	Motormaster® II Low Ambient Control - Enables cooling system to operate down to 0°F (-18° C) by cycling condenser fan on and off. The control is activated by a temperature sensor. No motor change-out required. One required per unit.	All Sizes 208/230-1-60 208/230-3-60 460-3-60 **
HC40GE231 / 1178185 <sup>1</sup>	Motormaster I Compatible Ball Bearing Fan Motor	036 – 208/230-1-60 208/230–3–60, 575–3–60†
HC40GE461 / 1178186 <sup>1</sup>	Motormaster I Compatible Ball Bearing Fan Motor	036 – 460-3-60
HC40GE233 / 1171974 <sup>1</sup>	Motormaster I Compatible Condenser Fan Motor	048–060 – 208/230-1-60 208/230-3-60, 575–3–60†
HC40GE463 / 1171975 <sup>1</sup>	Motormaster I Compatible Condenser Fan Motor	048–060 – 460–3–60
32LT-900---301	Motormaster I Single-Phase Solid-State Variable Speed Motor Controller enables cooling down to -20°F by varying the speed on the condenser fan.	All Sizes 208/230-1-60 208/203-3-60
32LT-900---611	Motormaster I Single-Phase Solid-State Variable Speed Motor Controller enables cooling down to -20° F (-29° C) by varying the speed on the condenser fan.	All Sizes 460-3-60
HC91CL010 / 1171807 <sup>1</sup>	MFD 10	Refer to MotorMaster I usage table

<sup>1</sup> Available from FAST Parts.

† Transformer HT01AH856 (0.75kva, 575V to 230V) and transformer bracket 50DK502263 is required

\* See usage tables in kit instructions.

\*\* One DNWINSTR001A00 also required per refrigerant circuit.

Sizes 036-060 require one (1) Low Ambient Controller and one (1) compatible condenser fan motor for change-out.