

PGD SERIES

7-1/2 Thru 15 Ton

TEMPSTAR®

Heating and Cooling Products

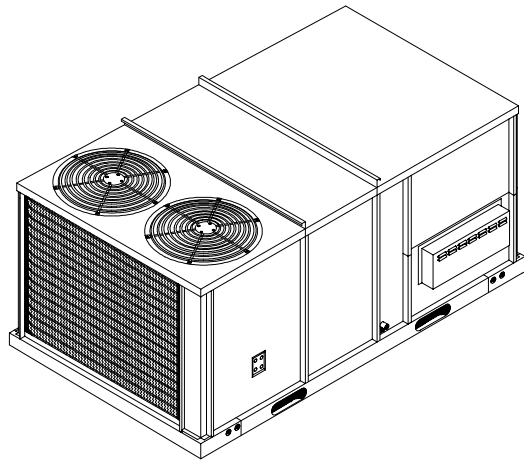

CONVERTIBLE SINGLE PACKAGE GAS/ELECTRIC

COMMERCIAL GAS/ELECTRIC UNIT FEATURES

CAPACITY

- 7-1/2 thru 15 ton Cooling, 200,000 thru 270,000 BTUH Heating

SINGLE PACKAGE

- Combination gas heating and electric cooling, self contained for year-round comfort. Systems can be installed on rooftop or ground level with the new convertible design.

CONSTRUCTION

- Triple step pre-painted galvanized steel cabinet for long lasting weatherproof construction. Access panels for easy service. Side by side supply and return. Heavy 16 gauge base with rails.

INTEGRAL BASE RAILS

- Fork-lift access on three sides. Holes provided for lifting lugs makes rooftop installation easier.

IMPROVED INSULATION

- Dual density insulation improves temperature separation.

COPPER TUBE/ALUMINUM FIN COILS

- Enhanced aluminium fins mechanically bonded to copper tubes for improved heat transfer.

FREEZE STAT

- Protects refrigeration circuits at low saturated suction temperatures.

HIGH & LOW PRESSURE SWITCH

- To provide excellent compressor protection.

EXTERNALLY-MOUNTED GAUGE PORTS

- Allows for more accurate reading of operating conditions while servicing.

INNOVATIVE EVAPORATOR BLOWER DESIGN

- "No Difference" Design allows the evaporator blower to deliver the same static capability for either horizontal or down discharge applications.

INTERNAL AIR FILTERS

- Easy access air filters to maintain a clean evaporator coil.

INDUCED DRAFT COMBUSTION SYSTEM

- For smoother combustion and optimal efficiency.

ALUMINIZED TUBULAR HEAT EXCHANGER

- Tubular design delivers efficient heat transfer and air flow: aluminized coating protects against corrosion.

IN-SHOT BURNERS

- New design delivers more complete, efficient combustion.

TWO STAGE COOLING

- Two independent circuits

TWO STAGE HEATING

PRE-WIRED FOR ECONOMIZER

- Designed for slide in, plug in economizer installation.

COMPRESSORS

- Scroll compressors on all units.

WARRANTY

- One (1) year limited warranty on parts
- Five (5) year limited warranty on the compressor
- Ten (10) year limited warranty on the gas fired heat exchanger



Rated in accordance with ARI Standard 210.



Listed By Underwriters' Laboratories

RESIDENTIAL AND COMMERCIAL SYSTEMS • SPLIT SYSTEMS • PACKAGED AIR CONDITIONERS
• COMBINATION GAS / ELECTRIC UNITS • HEAT PUMPS • AIR HANDLERS • MANUFACTURED
• HOME AIR CONDITIONERS • GAS, OIL AND ELECTRIC FURNACES

International Comfort Products
650 Heil-Quaker Avenue, Lewisburg, TN 37091

510 21 1001 03
9/3/2001

UNIT SPECIFICATIONS

Model Number		PGD090H200	PGD090L200	PGD090S200	PGD120H240	PGD120L240	PGD120S240	
Electrical Data	Volts-Phase-Hz.	208/230-3-60	460-3-60	600-3-60	208/230-3-60	460-3-60	600-3-60	
	Ampacity	39.8	18.7	14.9	60.2	25.7	19.6	
	MaxFuse	50	25	20	70	30	25	
Condenser Data	Coil	Total Face Area-Sq Ft	17.56			21.93		
		Fins Per In. / Rows	20 / 2			20 / 2		
		Tube Diameter (In.)	3/8			3/8		
	Fan	Horsepower / Quantity	3/4-1			3/4-2		
	Motor	Full Load Amps.	4.0	1.8	1.4	4.0	1.8	1.4
		Locked Rotor Amps.	10	4.3	3.3	10	4.3	3.7
	Fan	Size Diameter (In.)	1(24)			2(22)		
		RPM (Maximum)	1100			1100		
		CFM (Maximum)	5800x1			4600x2		
	Evaporator Coil	Coil	Total Face Area-Sq Ft	11.9			11.9	
Fins Per In. / Rows			14 / 2			14 / 3		
Tube Diameter (In.)			3/8			3/8		
Blower		H. P.	2	2	2	2	2	2
		Motor	Full Load Amps.	7.8	3.9	2.7	10.4	5.2
Locked Rotor Amps.			57.5	28.9	19.5	57.5	28.9	19.5
Blower		Type & Size	12x12 Belt Drive			12x12 Belt Drive		
		RPM (Maximum)	1800			1800		
		CFM Rated	3000			4000		
Compressor		Quantity / Type	2 / Scroll (Indepent Circuits)			2 / Scroll (Indepent Circuits)		
	Rated Load Amps.	#1	12.44	5.77	4.81	18.59	7.51	6.27
		#2	12.44	5.77	4.81	18.59	7.51	6.27
	Lock Rotor Amps.	#1	88	44	34	128	63	49
		#2	88	44	34	128	63	49
	Factory Refrig. Charge R-22 oz. per Circuit		#1 - 125 #2 - 125			#1 - 150 #2 - 150		
Weight	Shipping (Lbs.)	1095			1145			
Air Filter	Size / Quantity	20 x 25 x 2 / 4			20 x 25 x 2 / 4			

UNIT SPECIFICATIONS

Model Number		PGD150H270	PGD150L270	PGD150S270	PGD180H270	PGD180L270	PGD180S270	
Electrical Data	Volts-Phase-Hz.	208/230-3-60	460-3-60	600-3-60	208/230-3-60	460-3-60	600-3-60	
	Ampacity	68.1	33.0	24.4	79.1	39.3	27.9	
	MaxFuse	80	40	30	100	50	35	
Condenser Data	Coil	Total Face Area (Sq.Ft.)	22.58			27.37		
		Fins Per In. / Rows	20 / 2			20 / 2		
		Tube Diameter (In.)	3/8			3/8		
	Fan	Horsepower / Quantity	3/4-2			3/4 - 2		
	Motor	Full Load Amps.	4.0	1.8	1.4	4.0	1.8	1.4
		Locked Rotor Amps.	10	4.3	3.7	10	4.3	3.7
	Fan	Size Diameter (In.)	2(24)			2 (24)		
		RPM (Maximum)	1100			1100		
		CFM (Maximum)	5800x2			5800 x 2		
	Evaporator Coil	Coil	Total Face Area (Sq.Ft.)	16.19			16.19	
/ Fins Per In. / Rows			14 / 2			14 / 3		
Tube Diameter (In.)			3/8			3/8		
Blower		H. P.	3	3	3	3	3	3
		Motor	Full Load Amps.	14.6	7.4	3.6	14.6	7.4
Locked Rotor Amps.			73.0	37.0	21.8	73.0	37.0	21.8
Blower		Type & Size	15x15 Belt Drive			15x15 Belt Drive		
		RPM (Maximum)	1500			1500		
		CFM Rated	5000			6000		
Compressor		Quantity / Type	2 / Scroll (Indepent Circuits)			2 / Scroll (Indepent Circuits)		
	Rated Load Amps.	#1	19.86	9.6	7.89	28.85	14.74	10.77
		#2	20.71	9.98	8.17	20.43	9.88	8.08
	Lock Rotor Amps.	#1	156	70	54	195	95	80
		#2	156	70	54	156	70	54
	Factory Refrigerant Charge R-22 oz. per Circuit		#1 - 156 #2 - 156			#1 - 210 #2 - 210		
Weight	Shipping (Lbs.)	1245			1300			
Air Filter	Size / Quantity	20 x 30 x 2 / 4			20 x 30 x 2 / 4			

PERFORMANCE DATA: HEATING

Model Number	Heating Capacity Data				Capacity Stages%	Heating Thermal Efficiency		Temperature Rise Range-Deg. F	
	Input (MBTUH)		Output (MBTUH)			Heating	1st STAGE	2nd STAGE	1st STAGE
	1st STAGE	2nd STAGE	1st STAGE	2nd STAGE					
PGD090*200	134	200	104	160	66 / 100	78%	80%	15 - 45	30 - 60
PGD120*240	160	240	125	192	66 / 100	78%	80%	15 - 45	30 - 60
PGD150*270	180	270	141	216	66 / 100	78%	80%	15 - 45	30 - 60
PGD180*270	180	270	141	216	66 / 100	78%	80%	15 - 45	30 - 60

PERFORMANCE DATA: COOLING

Model Number	Rated Capacity ¹ BTUH	S/T Ratio	EER	I.P.L.V.	Capacity Stages% Cooling	Evaporator Rated Airflow
PGD090	85,000	.80	9.0	9.65	50 / 100	3000SCFM
PGD120	114,000	.77	9.0	8.30	50 / 100	4000SCFM
PGD150	141,000	.77	8.5	8.10	50 / 100	5000SCFM
PGD180	170,000	.77	8.5	8.45	56 / 100	6000SCFM

¹ Net Capacity Ratings based on ARI Test Standards, 95° F Amb. 80° F DB / 67° F WB.

MODEL NUMBER IDENTIFICATION GUIDE

MODEL NUMBER	P	G	D	090	H	200	A
Product Family							ENGINEERING DIGIT
P = Single Package							
Fuel Type							Gas Heat Input, MBTUH
G = Gas / Electric							270 = 270,000 240 = 240,000
Design Series							200 = 200,000
Capacity (Nominal BTU)							Electrical Characteristics
090 = 7-1/2 Ton 150 = 12-1/2 Ton							H = 208 / 230-3-60 L = 460-3-60 S = 600-3-60
120 = 10 Ton 180 = 15 Ton							

FORMULAS AND NOTES FOR USING EXPANDED PERFORMANCE DATA

To find leaving wet bulb and dry bulb from the expanded performance charts on the next two pages, use the following formulas. Direct interpolation is permissible. Do not extrapolate.

$$t_{/db} = t_{edb} - \frac{\text{sensible capacity (Btuh)}}{1.10 \times \text{cfm}}$$

$t_{/wb}$ = Wet-bulb temperature corresponding to enthalpy of air leaving evaporator coil ($h_{/wb}$).

$$h_{/wb} = h_{ewb} - \frac{\text{sensible capacity (Btuh)}}{4.5 \times \text{cfm}}$$

Where: h_{ewb} = Enthalpy of air entering evaporator coil.

LEGEND

MBh = Total Capacity (Gross)	S/T = Sensible to Total Ratio
KW = Unit Operating Watts	IDB = Indoor Dry Bulb
t_{/db} = Leaving Dry Bulb	t_{/wb} = Leaving Wet Bulb
edb = Entering Dry Bulb	ewb = Entering Wet Bulb
h_{/wb} = Enthalpy of leaving wet bulb	

CIRCULATING BLOWER PERFORMANCE DATA - 7 1/2 TON UNITS

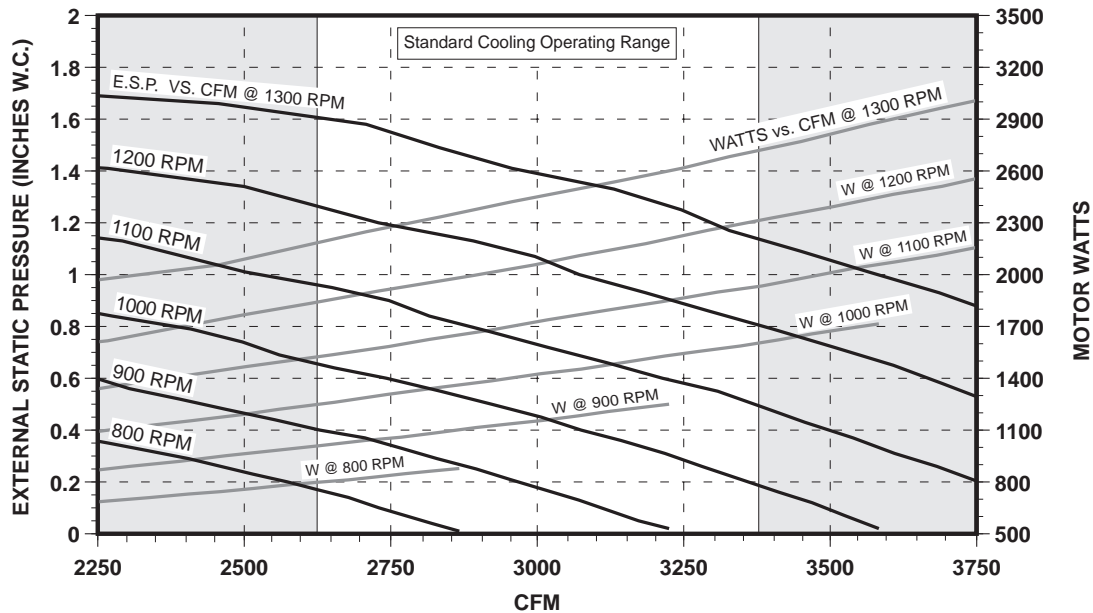

- NOTES: 1) Maximum motor Watts is 3200 Watts for 2 HP.
 2) Maximum blower wheel speed is 1800 RPM.
 3) Contact factory for applications requiring operation outside standard cooling operating range.
 4) Airflow data based on dry coil with filters. For wet coil add 0.08 inches to ESP. Downflow has the same ESP as horizontal flow.
 5) Add 0.05 inches to ESP for horizontal economizer, downflow economizer, or manual air dampers.
 6) Pulley turns refers to turns out. In other words, 0 turns is a narrower sheave than 5 turns.
 7) Blower speed MUST be set to give the correct air temperature rise through the unit as marked on the Rating Plate or in the Technical Support Manual.

CFM	EXTERNAL STATIC PRESSURE IN INCHES WATER COLUMN																				
	.25		.5		.75		1.0		1.25		1.50		1.75		2.0		2.25		2.5		
	RPM	W	RPM	W	RPM	W	RPM	W	RPM	W	RPM	W	RPM	W	RPM	W	RPM	W	RPM	W	
2500					1000	1250	1100	1500	1175	1700	1260	2000	1340	2250							
2750			960	1250	1050	1400	1140	1750	1224	2000	1290	2250	1360	2500							
3000	945	1250	1010	1500	1100	1750	1190	2000	1250	2250	1325	2600									
3250	1000	1550	1075	1800	1160	2100	1240	2400	1300	2600	1391	3050									
3500	1050	1800	1125	2150	1200	2250	1290	2600	1350	2800											

W = Watts High Static Data

PULLEY TURNS OPEN		0	1	2	3	4	5
FAN RPM	2 HP/STD PULLEY	1224	1139	1113	1057	1001	945
	2 HP/HI STATIC PULLEY	1391	1335	1280	1224	1169	1113

NOTE: High static pulleys are field installed and MUST be adjusted by the installing technician.

FACTORY SETTING TURNS OPEN	
2 HP/STANDARD PULLEY	4
2 HP/HI STATIC PULLEY *	(See NOTE)

AIRFLOW CORRECTION FACTORS - 7 1/2 TON

CFM - ACTUAL	2600	2800	3000	3200	3400
TOTAL MBH	0.97	0.98	1.00	1.02	1.03
SENSIBLE MBH	0.93	0.97	1.00	1.03	1.07
POWER KW	0.99	0.99	1.00	1.01	1.01

- NOTES: 1. Multiply correction factor times gross performance data.
 2. Resulting sensible capacity cannot exceed total capacity.

CIRCULATING BLOWER PERFORMANCE DATA - 10 TON UNITS

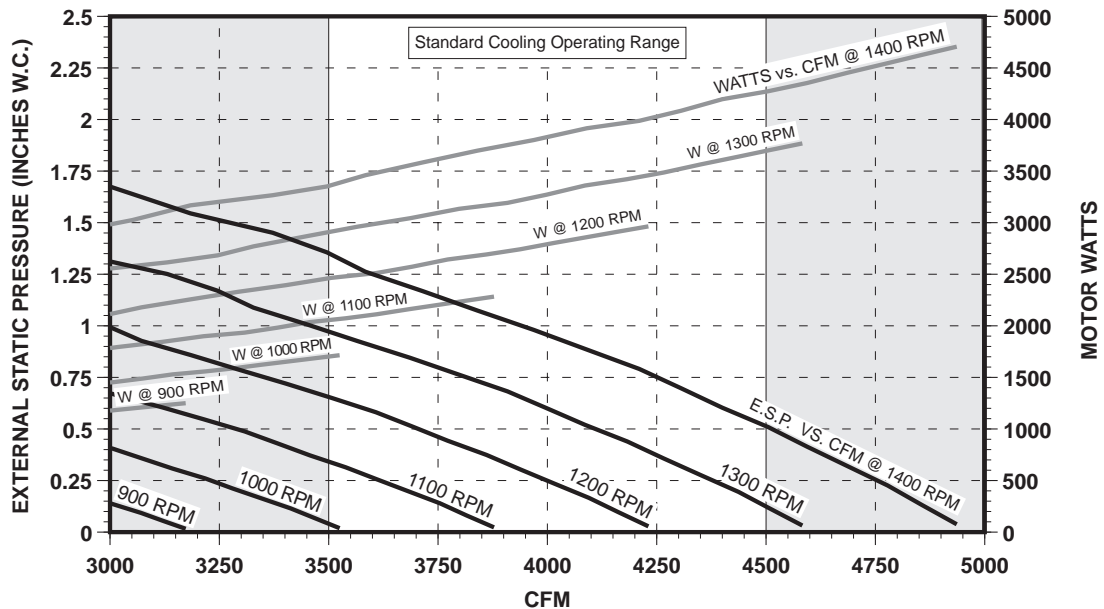

- NOTES:**
- 1) Maximum motor Watts is 4250 Watts for 2 HP and 4900 Watts for 3 HP.
 - 2) Maximum blower wheel speed is 1800 RPM.
 - 3) Contact factory for applications requiring operation outside standard cooling operating range.
 - 4) Airflow data based on dry coil with filters. For wet coil add 0.08 inches to ESP. Downflow has the same ESP as horizontal flow.
 - 5) Add 0.10 inches to ESP for horizontal economizer, downflow economizer, or manual air dampers.
 - 6) Pulley turns refers to turns out. In other words, 0 turns is a *narrower* sheave than 5 turns.
 - 7) Blower speed **MUST** be set to give the correct air temperature rise through the unit as marked on the Rating Plate or in the *Technical Support Manual*.

CFM	EXTERNAL STATIC PRESSURE IN INCHES WATER COLUMN																			
	.25		.5		.75		1.0		1.25		1.50		1.75		2.0		2.25		2.5	
	RPM	W	RPM	W	RPM	W	RPM	W	RPM	W	RPM	W	RPM	W	RPM	W	RPM	W	RPM	W
3500			1150	2250	1225	2600	1310	3000	1380	3250	1440	3625	1525	4000						
3750	1140	2375	1210	2700	1290	3000	1360	3350	1425	3750	1500	4200	1558	4400						
4000	1200	2800	1275	3125	1350	3600	1420	3850	1475	4250	1540	4550								
4250	1260	3250	1325	3625	1390	3900	1475	4500	1525	4650										
4500	1325	3850	1390	4250	1460	4600	1520	4900												

W = Watts High Static Data

PULLEY TURNS OPEN		0	1	2	3	4	5
FAN RPM	2 HP/STD PULLEY	1391	1335	1280	1224	1169	1113
	3 HP/HI STATIC PULLEY	1558	1502	1446	1391	1335	1280

NOTE: High static pulleys are field installed and **MUST** be adjusted by the installing technician.

FACTORY SETTING TURNS OPEN	
2 HP/STANDARD PULLEY	4
3 HP/HIGH STATIC PULLEY*	(See NOTE)

AIRFLOW CORRECTION FACTORS - 10 TON

CFM - ACTUAL	3200	3600	4000	4400	4800
TOTAL MBH	0.95	0.97	1.00	1.03	1.05
SENSIBLE MBH	0.89	0.95	1.00	1.05	1.11
POWER KW	0.98	0.99	1.00	1.01	1.02

- NOTES:**
1. Multiply correction factor times gross performance data.
 2. Resulting sensible capacity cannot exceed total capacity.

CIRCULATING BLOWER PERFORMANCE DATA - 12¹/₂ TON UNITS

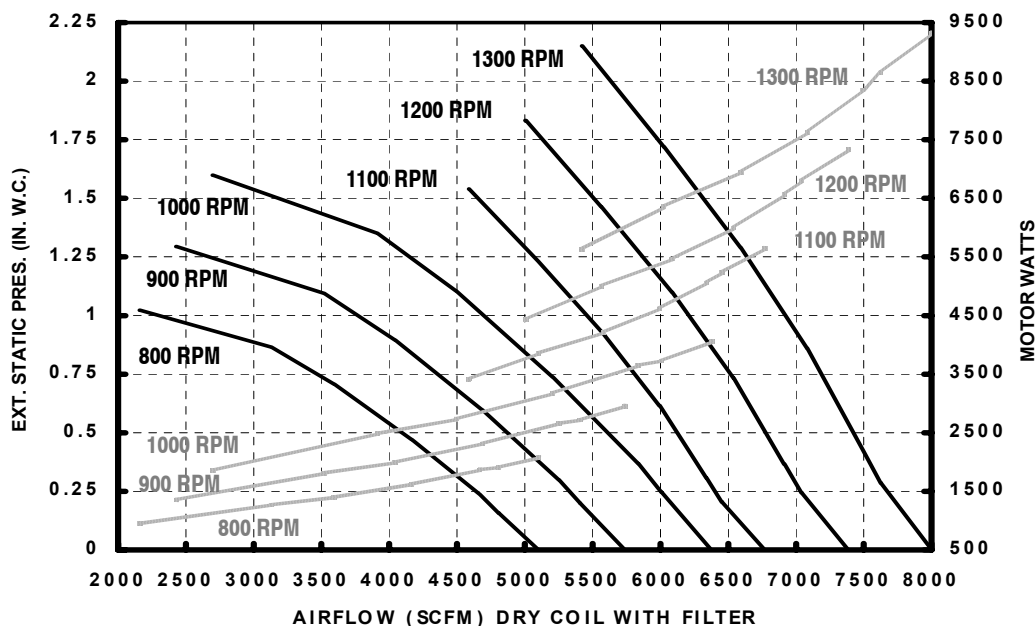

WATTS VS CFM

ESP VS CFM

- NOTES: 1) Maximum motor Watts is 5200 Watts for 3 HP, 6200 Watts for 5 HP.
 2) Maximum blower wheel speed is 1550 RPM.
 3) Contact factory for applications requiring operation outside standard cooling operating range.
 4) Airflow data based on dry coil with filters. For wet coil add 0.08 inches to ESP. Downflow has the same ESP as horizontal flow.
 5) Add 0.15 inches to ESP for horizontal economizer, downflow economizer, or manual air dampers.
 6) Pulley turns refers to turns out. In other words, 0 turns is a narrower sheave than 5 turns.
 7) Blower speed MUST be set to give the correct air temperature rise through the unit as marked on the Rating Plate .

EXTERNAL STATIC PRESSURE IN INCHES WATER COLUMN																
CFM	.25		.5		.75		1.0		1.25		1.5		1.75		2.0	
	RPM	W	RPM	W	RPM	W	RPM	W	RPM	W	RPM	W	RPM	W	RPM	W
4000	711	1245	787	1503	857	1783	922	2090	984	2420	1043	2771	1100	3142	1157	3529
4240	746	1459	819	1729	886	2020	948	2335	1006	2660	1065	3032	1121	3412	1174	3808
4500	781	1698	851	1982	915	2283	976	2607	1036	3014	1089	3320	1142	3707	1194	4113
4750	817	1964	883	2261	946	2574	1010	3021	1065	3370	1113	3657	1165	4031	1216	4445
5000	852	2258	917	2568	977	2893	1040	3363	1093	3737	1143	4082	1186	4349	1239	4806
5250	889	2581	950	2905	1020	3407	1071	3740	1122	4124	1172	4511	1217	4845	1256	5096
5500	925	2934	984	3273	1055	3828	1103	4156	1152	4541	1200	4953	1246	5341	1287	5664
5750	961	3320	1045	4021	1090	4291	1135	4613	1182	4995	1229	5419	1275	5846	1317	6231
6000	998	3740	1082	4523	1126	4795	1169	5114	1214	5491	1259	5918	1303	6368	1346	6801

W = Watts High Static Data

PULLEY TURNS OPEN		0	1	2	3	4	5
FAN RPM	3 HP/STD PULLEY	1086	1049	1012	976	939	902
	5 HP/HI STATIC PULLEY	1172	1135	1098	1062	1025	988

NOTE: High static pulleys are field installed and MUST be adjusted by the installing technician. 5 HP motor requires a blower pulley change.

FACTORY SETTING TURNS OPEN	
3 HP/STANDARD PULLEY	4
5 HP/HI STATIC PULLEY *	(See NOTE)

AIRFLOW CORRECTION FACTORS - 12 1/2 TON					
CFM - ACTUAL	4000	4500	5000	5500	6000
TOTAL MBH	0.95	0.98	1.00	1.02	1.05
SENSIBLE MBH	0.90	0.95	1.00	1.05	1.10
POWER KW	0.98	0.99	1.00	1.01	1.02

- NOTES: 1. Multiply correction factor times gross performance data.
 2. Resulting sensible capacity cannot exceed total capacity.

CIRCULATING BLOWER PERFORMANCE DATA - 15 TON UNITS

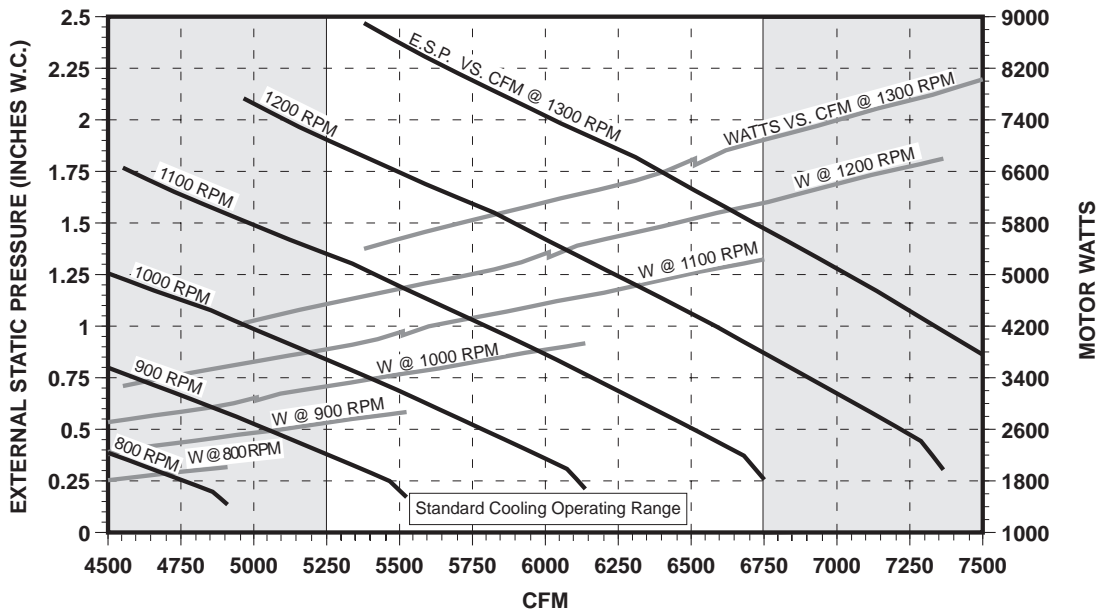

- NOTES:**
- 1) Maximum motor Watts is 5200 Watts for 3 HP; 6200 Watts for 5 HP.
 - 2) Maximum blower wheel speed is 1550 RPM.
 - 3) Contact factory for applications requiring operation outside standard cooling operating range.
 - 4) Airflow data based on dry coil with filters. For wet coil add 0.08 inches to ESP. Downflow has the same ESP as horizontal flow.
 - 5) Add 0.20 inches to ESP for horizontal economizer, downflow economizer, or manual air dampers.
 - 6) Pulley turns refers to turns out. In other words, 0 turns is a *narrower* sheave than 5 turns.
 - 7) Blower speed **MUST** be set to give the correct air temperature rise through the unit as marked on the Rating Plate or in the *Technical Support Manual*.

CFM	EXTERNAL STATIC PRESSURE IN INCHES WATER COLUMN																			
	.25		.5		.75		1.0		1.25		1.50		1.75		2.0		2.25		2.5	
	RPM	W	RPM	W	RPM	W	RPM	W	RPM	W	RPM	W	RPM	W	RPM	W	RPM	W	RPM	W
5250	875	2500	925	2875	975	3075	1025	3450	1075	3625	1125	4000	1175	4375	1220	4750				
5500	900	2875	960	3150	1010	3525	1060	3825	1110	4250	1150	4375	1200	4750	1236	5000				
5750	950	3250	1000	3625	1050	3900	1100	4375	1140	4600	1180	4825	1230	5125						
6000	990	3625	1025	4000	1075	4375	1125	4750	1160	4900	1215	5500								
6250	1025	4200	1060	4475	1110	4850	1160	5200	1200	5600										
6500	1060	4700	1100	5025	1150	5450	1190	5800	1236	6000										
6750	1100	5125	1140	5500	1180	5875														

W = Watts

High Static Data

PULLEY TURNS OPEN		0	1	2	3	4	5
FAN RPM	3 HP/STD PULLEY	1150	1097	1045	993	940	888
	5 HP/HI STATIC PULLEY	1236	1172	1107	1042	977	911

NOTE: High static pulleys are field installed and **MUST** be adjusted by the installing technician. 5 HP motor requires a *blower* pulley change.

FACTORY SETTING TURNS OPEN	
3 HP/STANDARD PULLEY	4
5 HP/HI STATIC PULLEY *	(See NOTE)

AIRFLOW CORRECTION FACTORS - 15 TON

CFM - ACTUAL	4800	5400	6000	6600	7200
TOTAL MBH	0.95	0.98	1.00	1.02	1.05
SENSIBLE MBH	0.90	0.95	1.00	1.05	1.10
POWER KW	0.98	0.99	1.00	1.01	1.02

- NOTES:**
1. Multiply correction factor times gross performance data.
 2. Resulting sensible capacity cannot exceed total capacity.

UNIT DIMENSIONS

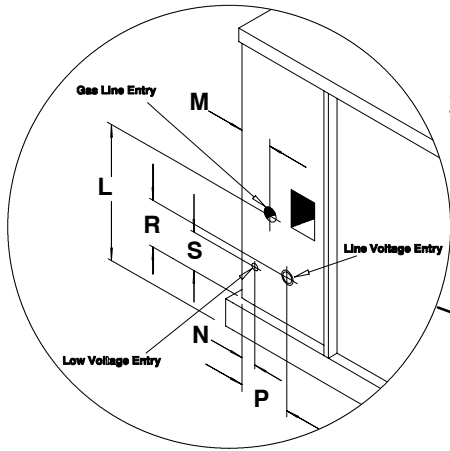

Gas Pipe Inlet
3/4" - 14 N.P.T.
Threaded

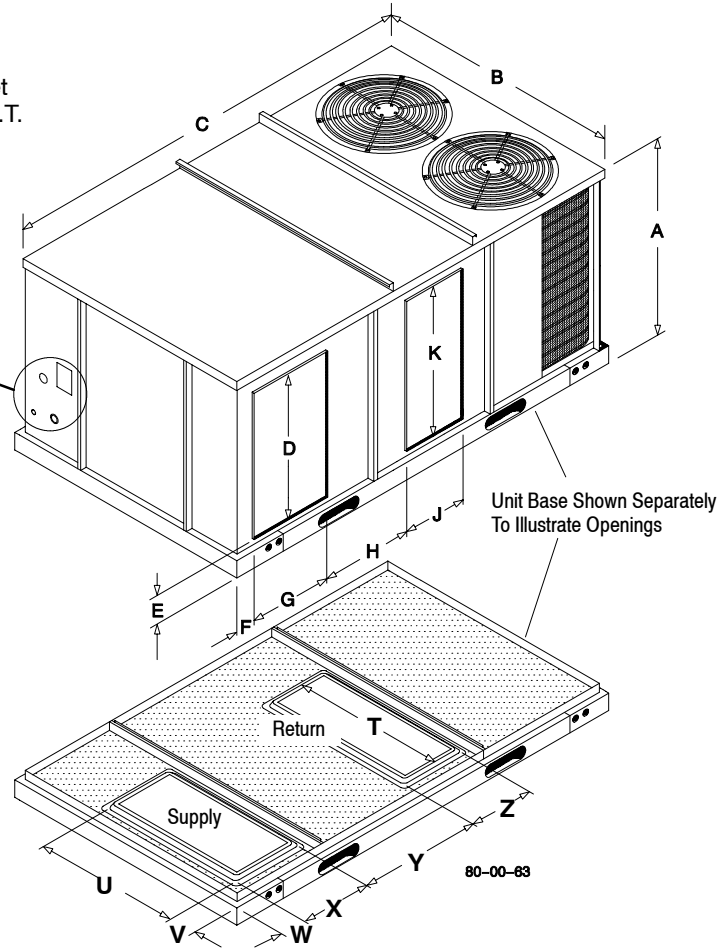

**NOTE: For down discharge,
duct connections to curb only.**

**ALL DIMENSIONS IN INCHES
DIMENSIONS FROM BASE LEVEL**

Unit Size	A	B	C	D	E
7-1/2 & 10 Ton	44-13/16	57-9/16	90-11/16	32-1/16	5-1/8
12-1/2 & 15 Ton	48-13/16	68-1/8	99-15/16	41-3/16	5-1/8

Unit Size	F	G	H	J	K
7-1/2 & 10 Ton	4-5/16	18-1/4	16-7/16	14-9/16	36-1/16
12-1/2 & 15 Ton	4-1/2	21-9/16	15-1/4	21-9/16	41-3/16

Unit Size	L	M	N	P	R	S	T	U	V	W	X	Y	Z
7-1/2 & 10 Ton	10-1/2	3-9/16	2	5-7/8	4-3/4	3-1/2	39-1/8	35-1/16	3-1/2	3-1/2	21-3/16	12-7/8	17-1/2
12-1/2 & 15 Ton	10-1/2	5-1/2	2	5-7/8	4-3/4	3-1/2	45-1/16	45-1/16	3-1/2	3-1/2	24-1/2	11-13/16	24-1/2

ACCESSORIES

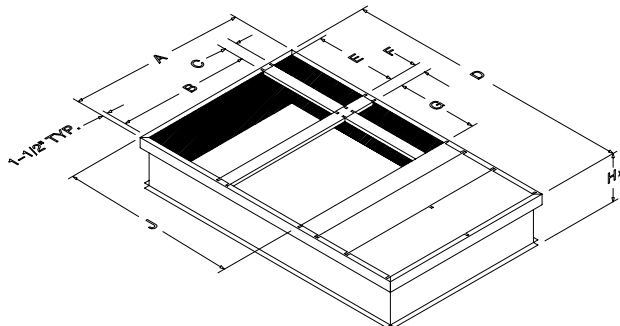

ROOF CURB DIMENSIONS

Model No.	Unit Size	A	B	C	D	E	F	G	H	J
AXB040C**	7-1/2 & 10 Ton	51	38-1/2	3-1/2	84-1/8	23-3/4	3-1/2	23-3/4	See	52-1/2
AXB050C**	12-1/2 - 20 Ton	61-1/2	44	3-1/2	93-3/8	28-1/2	3-1/4	28-1/2	below	61-3/4

* Roof Curbs come in 3 heights: Model # Letter L = 8", M = 14", H = 24"

ECONOMIZERS / DOWNFLOW (Use with 7 1/2 thru 20 Tons)

AXB040/050ECA (Entry Level - Three Position)

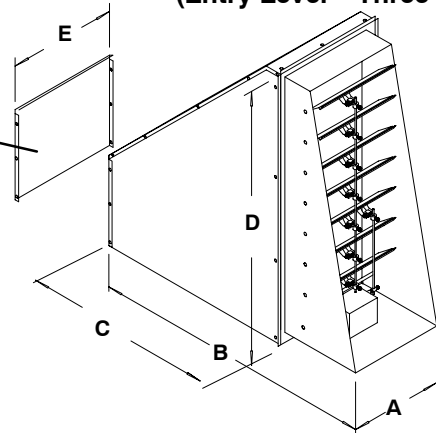
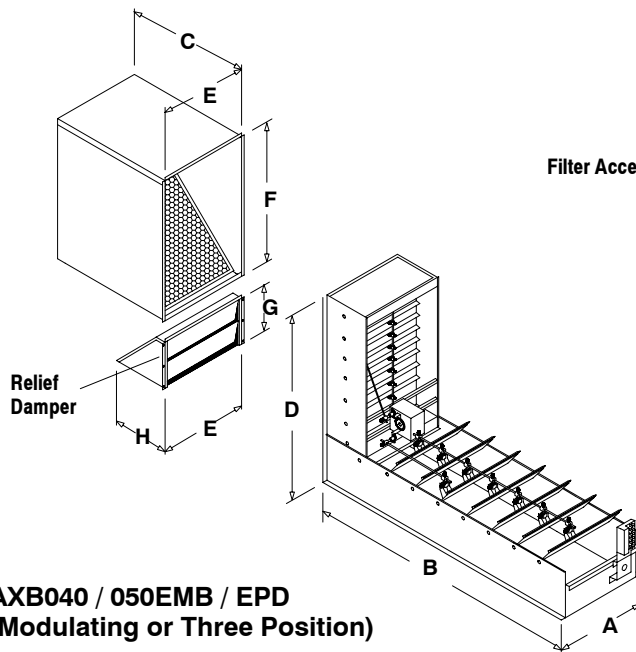

80-00-53

Model No.	A	B	C	D	E
AXB040ECA	12-7/16	37	26	37-3/8	14-7/16
AXB050ECA	18-1/2	37	26	42 1/2	21

ALL DIMENSIONS IN INCHES

AXB040 / 050EMB / EPD (Modulating or Three Position)

Model No.	A	B	C	D	E	F	G	H
AXB040E**	16 3/4	44-5/8	25 1/2	38 1/8	17-9/16	28-7/8	9-1/2	11 1/2
AXB050E**	23 3/4	56	25 1/2	41-3/4	23 11/16	31-3/4	9-1/2	11 1/2

Description	Model Number	Used on
Fully Modulating (1)	AXB040EMC	7 1/2 to 10 Ton
Three Position (2)	AXB040EPD	
Entry Level Three Position (3)	AXB040ECA	

Description	Model Number	Used on
Fully Modulating (1)	AXB050EMC	12 1/2 to 20 Ton
Three Position (2)	AXB050EPD	
Entry Level Three Position (3)	AXB050ECA	

NOTES:

- (1) - Ambient/Enthalpy Control; Includes Return Air Damper & Relief Damper.
 (3) - Ambient Control Only; No Return Air Damper; No Relief Damper.

- (2) - Ambient Control Only; Includes Return Air Damper & Relief Damper.

All Economizers Feature Enthalpy and/or ambient temperature control providing outdoor air ventilation and "free cooling" when outdoor conditions are favorable.

Return Air and Pressure Relief dampers for proper air balance, on most models.

Interconnecting wiring furnished.

Center controlled dual action dampers with gaskets to provide proper seal.

Description	Model Number	Used on
Fully Modulating (1)	AXB040HEC	7 1/2 to 10 Ton
Three Position (2)	AXB040HPD	

Description	Model Number	Used on
Fully Modulating (1)	AXB050HEC	12 1/2 to 20 Ton
Three Position (2)	AXB050HPD	

NOTES:

- (1) - Ambient/Enthalpy Control; Includes Return Air Damper & Relief Damper.
 (2) - Ambient Control Only; Includes Return Air Damper & Relief Damper.

ECONOMIZERS / HORIZONTAL

AXB040/50H**

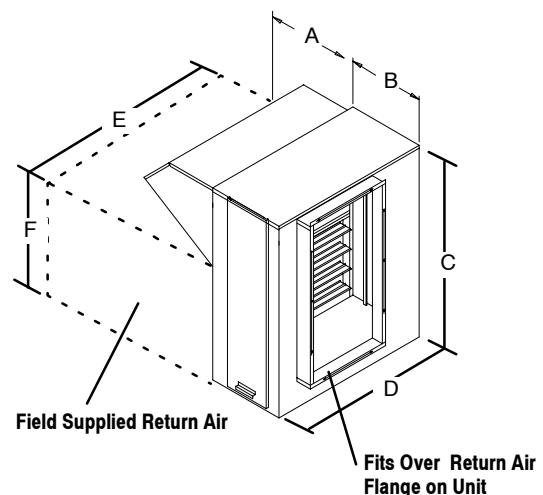

HORIZONTAL ECONOMIZER DIMENSIONS						
Model No.	A	B	C	D	E	F
AXB040	20-7/8	20-1/8	46-3/8	30-5/8	28-15/16	21-1/4
AXB050	20-7/8	20-1/8	50-3/8	42-1/2	40-13/16	21-1/4

ACCESSORIES (CONT...)

FOR DETAILED INFORMATION ON ACCESSORIES, SEE SYSTEM ACCESSORY GUIDE P.N. 401 10 1001 00.
ALL WEIGHTS ARE INSTALLED & IN POUNDS

ROOF CURBS

Description	Model Number / Weight	Used on
8"	AXB040CLA / 88	7 1/2 to 10 Ton
	AXB050CLA / 100	12 1/2 to 15 Ton
14"	AXB040CMA / 108	7 1/2 to 10 Ton
	AXB050CMA / 124	12 1/2 to 15 Ton
24"	AXB040CHA / 149	7 1/2 to 10 Ton
	AXB050CHA / 167	12 1/2 to 15 Ton

ECONOMIZERS - DOWNFLOW

Description	Model Number / Weight	Used on
Fully Modulating	AXB040EMC / 145	7 1/2 to 10 Ton
	AXB050EMC / 175	12 1/2 to 15 Ton
Three Position, with Return Air Damper	AXB040EPD / 145	7 1/2 to 10 Ton
	AXB050EPD / 175	12 1/2 to 15 Ton
Three Position, no Return Air Damper	AXB040ECA / 120	7 1/2 to 10 Ton
	AXB050ECA / 140	12 1/2 to 15 Ton

ECONOMIZERS - HORIZONTAL

Description	Model Number / Weight	Used on
Fully Modulating	AXB040HEC / 214	7 1/2 to 10 Ton
	AXB050HEC / 250	12 1/2 to 15 Ton
Three Position	AXB040HPD / 214	7 1/2 to 10 Ton
	AXB050HPD / 250	12 1/2 to 15 Ton

PART NUMBERS FOR APPROVED HIGH STATIC CONVERSIONS *

Unit Size	Motor	Motor Pulley	Blower Pulley	Belt
7 1/2 Ton	No Change	521096	No change	1110512
10 Ton 208/230 - 460 volt	1070646	No change	1097233	1098441
10 Ton 575 volt	1070656	No change	1097233	1098441
12 1/2 Ton 208/230 - 460 volt	1071520	521096	1110513	1098617
12 1/2 Ton 575 volt	1071519	521096	1110513	1098617
15 Ton 208/230 - 460 volt	1071520	521096	1110513	1098617
15 Ton 575 volt	1071519	521096	1110513	1098617

* Available through Service Parts

OUTDOOR AIR DAMPERS

Description	Model Number / Weight	Used on
Manual 0- 25%	AXB040FAC / 12	7 1/2 to 10 Ton
	AXB050FAC / 26	12 1/2 to 15 Ton
Motorized- 25%	AXB040FMC / 27	7 1/2 to 10 Ton
	AXB050FMC / 41	12 1/2 to 15 Ton

LOW AMBIENT CONTROLS *

Description	Model Number - Weight	Used on
To 0° F	1071675 / 3	7 1/2 to 15 Ton

COIL PROTECTION *

Description	Model Number	Used on
Coil Guard	AGC05PU0A	7 1/2 Ton
	AGC06PU0A	10 Ton
	AGC07PU0A	12 1/2 Ton
	AGC08PU0A	15 Ton
Hail Guard	AGH05PU0A	7 1/2 Ton
	AGH06PU0A	10 Ton
	AGH07PU0A	12 1/2 Ton
	AGH08PU0A	15 Ton

* Available through Service Parts

FOSSIL FUEL CONVERSION

Description	Model Number	Used on
Natural to LP Gas	1071350	200 - 270 MBTUH
LP to Natural Gas	1071353	200 - 270 MBTUH

CONCENTRIC DUCT KITS

Description	Model Number / Weight	Used on
Square to Round	AXB040CTA ** / 25	7 1/2 Ton

** Includes two square to round boxes. Units over 7 1/2 Ton use rectangular duct connections to the concentric grilles and do not require transition accessory.

CONCENTRIC DIFFUSER (FLUSH MOUNT)

Description	Model Number / Weight	Used on
Concentric Diffuser (F.M.)	AXB040CFA / 55	7 1/2 Ton
Concentric Diffuser (F.M.)	AXB045CFA / 165	10 Ton
Concentric Diffuser (F.M.)	AXB050CFA / 190	12 1/2 Ton
Concentric Diffuser (F.M.)	AXB055CFA / 235	15 Ton

CONCENTRIC DIFFUSER (STEP DOWN)

Description	Model Number / Weight	Used on
Concentric Diffuser (S.D.)	AXB040CSA / 180	7 1/2 Ton
Concentric Diffuser (S.D.)	AXB045CSA / 185	10 Ton
Concentric Diffuser (S.D.)	AXB050CSA / 247	12 1/2 Ton
Concentric Diffuser (S.D.)	AXB055CSA / 260	15 Ton

NOTES

GUIDE SPECIFICATION

CABINET

The cabinet shall be made of sturdy triple step pre-painted G-90 galvanized steel for long lasting weatherproof construction. Base rails shall be made of 16 gauge steel and have fork lift slots plus holes provided for lifting shackles. Unit shall be designed with convertible airflow and are shipped ready for downflow applications with conversion to horizontal airflow being accomplished by relocating two panels. The indoor blower compartment interior cabinet surfaces shall be insulated with a minimum 1/2" thick, flexible glass fiber insulation, coated on the air side. Aluminum foil faced glass fiber insulation shall be used in the furnace compartment.

COOLING SECTION

Units shall be factory charged and operationally ready upon delivery. The unit shall have two independent refrigerant systems providing two stage cooling operation. Each refrigerant circuit shall have a high efficiency, fully hermetic scroll compressor with internal overload protection, high and low pressure switches, filter drier, and copper tube / aluminum fin evaporator and condenser coils. The unit shall be designed for two-stage cooling operation down to 40° F. as shipped, as well as pre-wired for economizer-type accessories.

COILS

The evaporator and condenser coils shall be fabricated with aluminum fins mechanically bonded to copper tubing. Both coils shall be pressure tested prior to assembly into the unit and electronically leak tested after assembly into the unit. The evaporator coil shall be protected from dust and debris on the return air side by factory installed 2" low velocity glass fiber air filters. Filter face velocity shall not exceed 220 FPM for 7-1/2 ton units, 290 FPM for the 10 ton units, 365 FPM for the 12-1/2 ton units and 440 FPM for the 15 ton units.

CONDENSER FAN(S)

The 7-1/2 ton units shall have a single direct-drive propeller-fan/motor assembly; the 10 thru 15 ton units shall have two condenser fan assemblies. The assemblies shall be mounted directly to a vertical-discharge grille that is easily removable for service. Motors shall be rated at 1100 RPM and shall have permanently lubricated ball bearings and internal overload protection.

EVAPORATOR BLOWER

The 7-1/2 thru 15 ton units shall have a single belt driven evaporator blower and it shall have permanently lubricated ball bearings and internal overload protection. An adjustable motor drive sheave for matching air flow requirements shall be standard. Additionally, high static kits shall be available for air flows above the standard requirement. The external static capability of the unit shall be the same for horizontal and downflow discharge.

HEATING SECTION

The units shall have aluminized steel tubular heat exchangers located on the discharge side of the evaporator blower and equipped with a two stage gas valve. The units shall have in-shot burners that are ignited by an electronic spark with flame proving feature and protected by both a limit switch and flame roll-out switch. The induced draft blower shall have a two-speed motor and shall be interlocked with a proven air pressure safety device.

INSTALLATION CLEARANCES

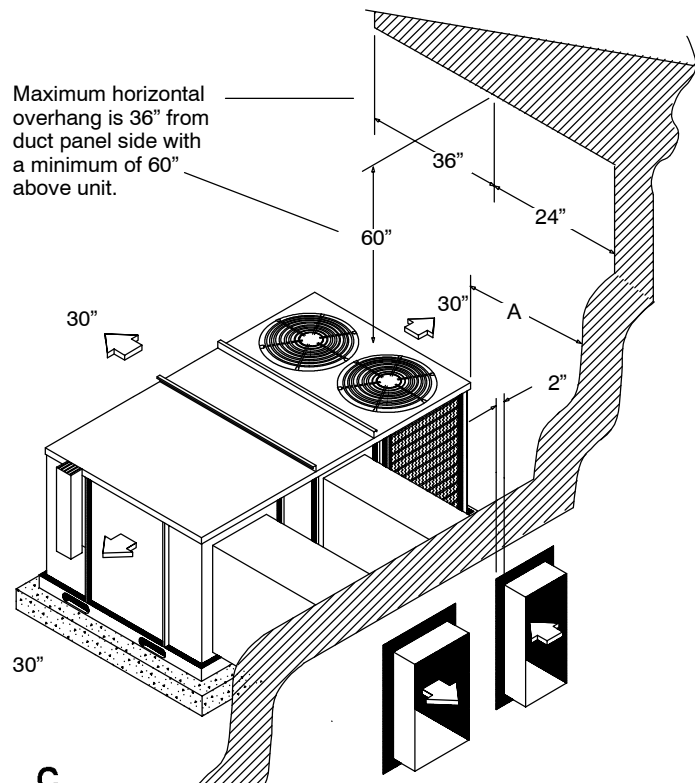

A = 24" with no economizer; 48" with economizer.

RIGGING DETAILS

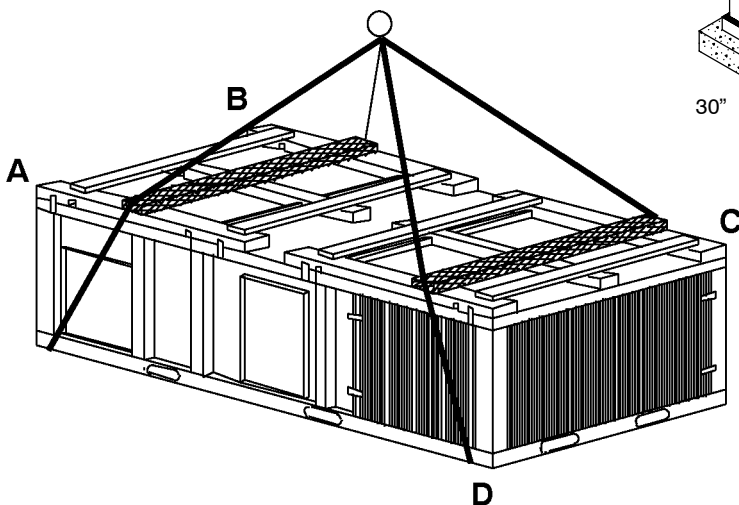

CORNER WEIGHTS (LBS)

UNIT SIZE (Ton)	A	B	C	D	OPERATING WEIGHT TOTAL
7-1/2	222	317	316	220	1,075
10	232	332	330	231	1,125
12-1/2	253	362	359	251	1,225
15	264	376	373	262	1,275