

**BULLETIN NO. IM 417-3  
JANUARY, 1991  
FORM NO. 711159A-50**

**PACKAGED ROOFTOP SYSTEMS  
MODELS CUR251, CUR300 & CUR351**

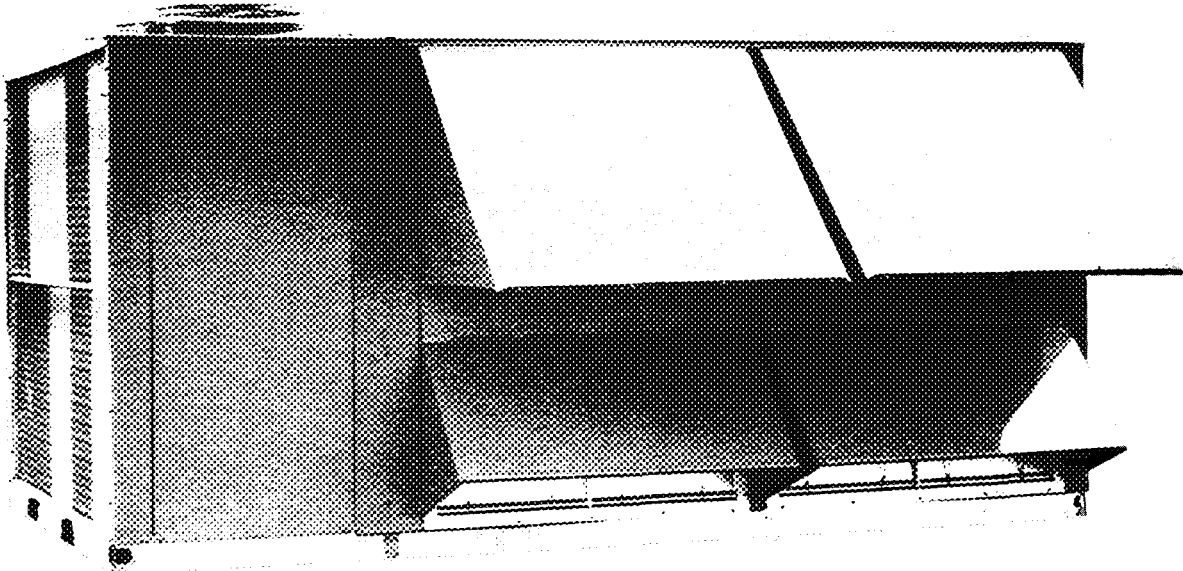

## TABLE OF CONTENTS

NOMENCLATURE	3
RECEIVING, INSPECTION & UNPACKING	3
UNIT DESCRIPTION	3
INSTALLATION	4
ROOF CURB ASSEMBLY & INSTALLATION	4
HANDLING & RIGGING	6
SERVICE CLEARANCES	7
UNIT INSTALLATION ON ROOF CURB	7
DUCT CONNECTIONS	8
Vertical Discharge	8
Horizontal Discharge	9
OUTSIDE AIR INTAKE HOOD	9
POWER EXHAUST RAIN HOOD	10
DISCHARGE AIR DAMPER — VAV ONLY	10
DIFFERENTIAL PRESSURE SWITCH — VAV ONLY	10
Installation of Pressure Sensing Tubing	10
Sequence of Operation	11
POWER EXHAUST FAN	11
TRACKING DAMPER — VAV ONLY	12
ELECTRICAL INSTALLATION	12
Main Power Wiring	12
Low Voltage Control Wiring — Constant Volume Units	13
Low Voltage Control Wiring — VAV Units	15
Unit Wiring Diagrams	16
GAS SUPPLY PIPING	28
HYDRONIC PIPING & WIRING	29
CONDENSATE DRAIN CONNECTION	29
SYSTEM CHECK, TEST & START	30
Before Startup	30
Control System	31
Economizer Dampers & Filters	31
Evaporator Blower Fan & Power Exhaust	32
Sequencer (W7100) — VAV Only	35
Refrigeration System	35
Differential Pressure Switch — VAV Only	37
Central Control Panel	37
Gas Heat	39
Electric Heat	41
Thermostat, Night Setback & Timeclock	41
NORMAL OPERATING CONDITIONS	42
AIR BALANCING	43
MAINTENANCE	44
CONTROLS, SETTINGS AND FUNCTIONS	46
PARTS LIST	48
SERVICE & WARRANTY PROCEDURE	51
PRODUCT WARRANTY	51

Copyright © 1989 SnyderGeneral Corporation, Minneapolis, MN. All rights reserved throughout the world.  
"Bulletin illustrations cover the general appearance of SnyderGeneral Corporation products at the time of publication  
and we reserve the right to make changes in design and construction at any time without notice."

# NOMENCLATURE

## CUR 251 E T H

COMMERCIAL UNITARY  
ROOFTOP UNIT

NOMINAL CAPACITY

251=25 Tons  
300=30 Tons  
351=35 Tons

DESIGN VINTAGE

HEAT MEDIUM

Y= Cooling Only  
H= Natural Gas (High Heat)  
K= Natural Gas (High Heat/High Altitude)  
L= Natural Gas (Low Heat)  
J= Natural Gas (Low Heat/High Altitude)  
P= Propane Gas  
Z= Propane Gas (High Altitude)  
W= Hot Water or Steam  
2-9= Electric

VOLTAGE

T= 460/60/3  
F= 208-230/60/3  
W= 575/60/3

## RECEIVING, INSPECTION & UNPACKING

When the equipment is received all items should be carefully checked against the bill of lading to be sure all crates and cartons have been received. Before accepting delivery, carefully inspect each carton or crate for visible shipping damage. If any damage is noticed, the carrier should make the proper notation on the delivery receipt acknowledging the damage. Make notations of all damage on all copies of the bill of lading and have all copies countersigned by the delivering carrier. The carrier should also fill out a Carrier Inspection Report. The factory Traffic Department should then be contacted. File claim for damage with the carrier.

Unpack each carton or crate and verify that all required parts and proper quantities of each item have been received. Refer to drawings for part descriptions. Report shortages or missing items to your local representative to arrange for replacement parts.

Due to particular situations with availability of carriers and truck space, it is not possible to guarantee that all items will be shipped together. Verification of shipments must be limited to only those items on the bill of lading.

**The unit nameplate must be checked to make sure the voltage agrees with the power supply available.**

## UNIT DESCRIPTION

Rooftop units are shipped fully assembled and factory tested. They are generally installed on a steel roof curb assembly which has been shipped to the jobsite for installation on the roof structure prior to the arrival of the unit.

The model number shown on the unit identification plate identifies the various components of the unit such as refrigeration tonnage, vintage, and voltage as shown above in the nomenclature.

Figure 1. Typical Component Location

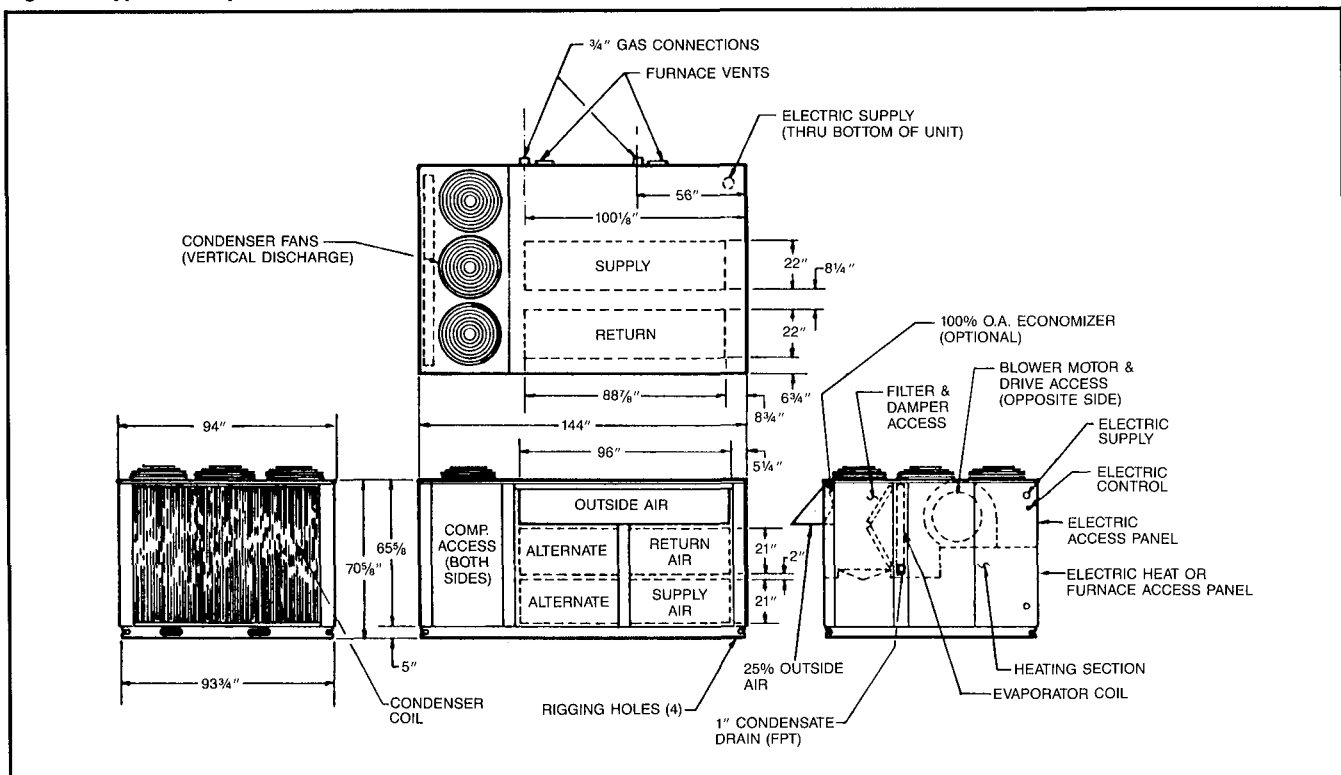

## INSTALLATION

The installation of this equipment shall be in accordance with the regulations of authorities having jurisdiction and all applicable codes. It is the responsibility of the installer to determine and follow the applicable codes.

Sheetmetal parts, screws, clips and similar items inherently have sharp edges, and it is necessary that the installer and service personnel exercise caution.

This equipment is to be installed by an experienced installation company and fully trained personnel.

The mechanical installation of the packaged rooftop units consist of making final connections between the unit and building services; supply and return duct connections; drain connections (if required) and setup of rainhood over outside air intake opening.

The internal systems of the unit are completely factory installed and tested prior to shipment and no additional field labor is required.

## ROOF CURB ASSEMBLY & INSTALLATION

### GENERAL

1. Roof curbs are shipped unassembled. Field assembly, leveling and mounting on roof structure are the responsibility of the contractor.
2. All required hardware necessary for assembly is supplied and included in curb assembly.
3. 710058A-03, when used with the CUR251E, CUR300E and CUR351E units, is not a full perimeter curb. The condenser section of the unit overhangs the curb. For these same units, 710058A-04 is a full perimeter curb.
4. Curbs must be supported by three parallel roof members: one under each long side (refer to Figure 3) and one under the divider member which separates the return and supply ducts (item ③ in Figure 5). Primary and secondary roof members must not penetrate supply/return duct opening area.
5. Curb insulation, cant strip and counterflashing to be supplied by contractor. Wood nailing strip and unit isolator furnished and installed by manufacturer.

### INSPECTION

1. Before accepting curb delivery, inspect each carton or crate for visible shipping damage. Make notations of all damage on all copies of bill of lading and have all copies countersigned by the delivering carrier. File claim for damage with the carrier.
2. Unpack each carton and verify that all required parts and proper quantities of each item as shown on bill of material have been received. Report shortages or missing items to delivering carrier and notify your local representative to arrange for replacement.

### ASSEMBLY

1. Position items ① ② ③ and ④ (item ④ not used on 710058A-03) as shown and in accordance with job requirements. Check lengths of all pieces against bill of material to insure proper placement and assembly.
2. For partial curb (710058A-03), assemble the divider channel ③ with a side channel ①; then add front and rear channels ②. Refer to Figures 4 and 5. Complete the assembly by adding the other side channel ①. Use bolts, washers and nuts provided. Hand tighten only at this time. For full perimeter curb (710058A-04), assemble divider channel ③ between side channel ① and divider channel ④. Next, assemble front and rear channels ② to side channel ① and divider channel ④. Complete assembly by adding other side channel ①. Hand tighten only at this time. **NOTE:** Flanges on item ① must go on outside of item ② and under wood nailer strip.
3. The assembled roof curb should now be checked for squareness. The curb assembly must be adjusted until both diagonal measurements (131 $\frac{3}{8}$ " for 710058A-03 and 158 $\frac{1}{8}$ " for 710058A-04) are equal within a tolerance of  $\pm \frac{1}{8}$ ". All hand tightened fasteners should now be fully secured.

Figure 2.

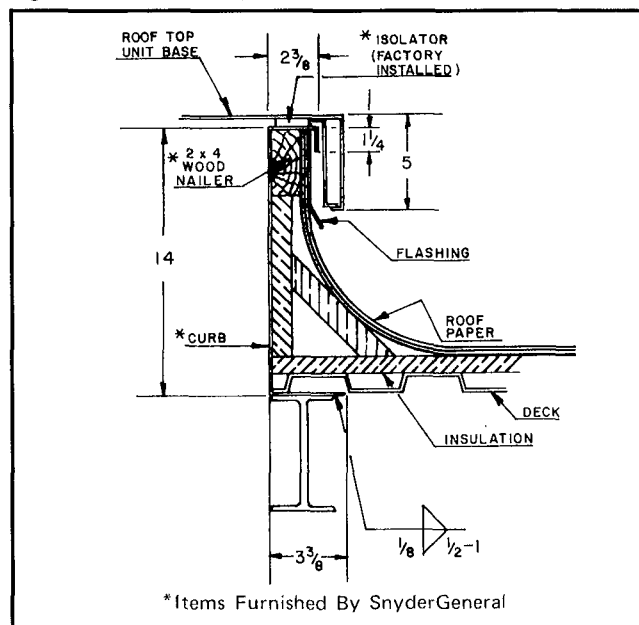

Figure 3.

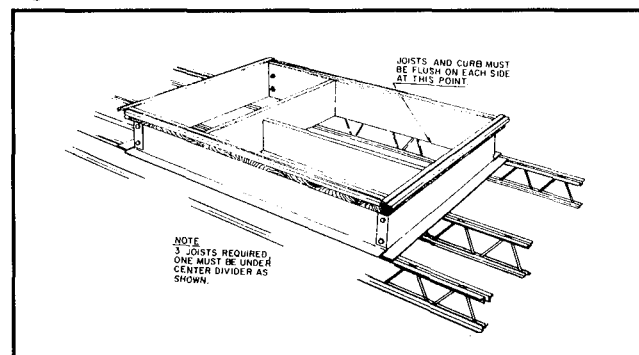

Figure 4.

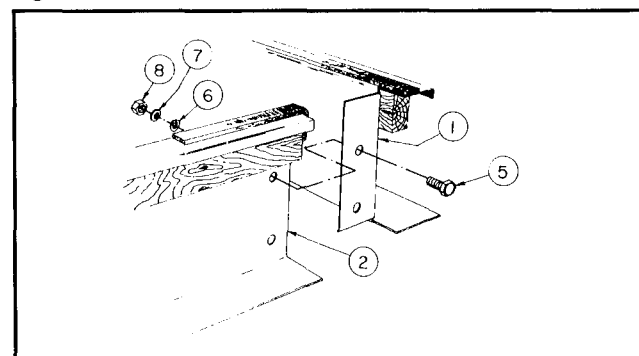
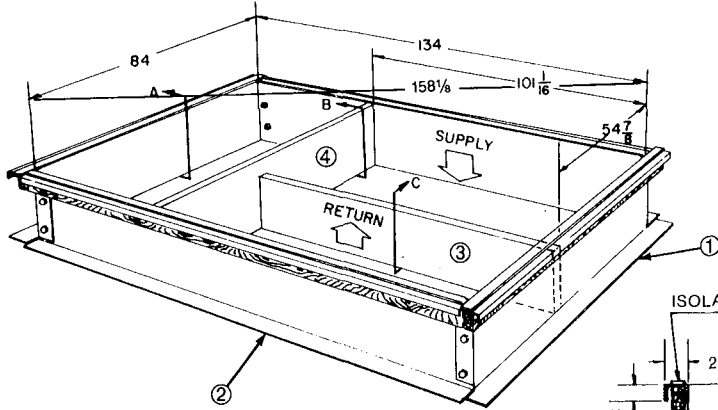
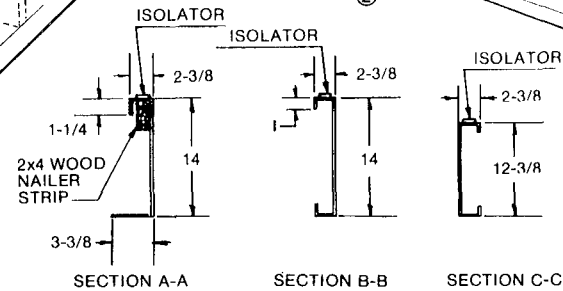
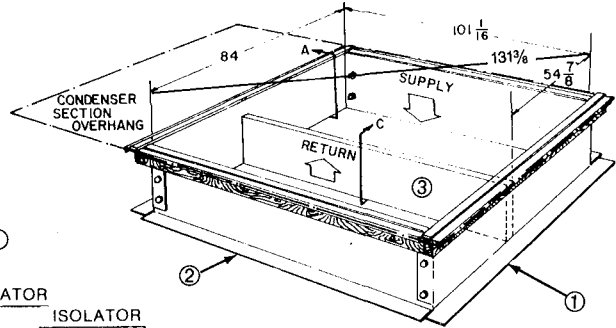

Figure 5.

**ROOF CURB 710058A-04  
FULL PERIMETER FOR 25, 30 & 35 TON UNITS**



**ROOF CURB 710058A-03  
CANTILEVER FOR 25, 30 & 35 TON UNITS**



**INSTALLATION & LEVELING**

1. Place assembled curb in proper location on roof joists. Recheck for squareness and adjust if required.
2. Curb must be installed level and may require contractor to supply and install shims.
3. One method to achieve level installation is to stretch two diagonal lines across curb and equip them with line levels. There must not be more than 1/8" spacing between the two lines at the point of intersection. Should the lines touch at the intersection, recheck by placing the bottom line on top. Shim curb as required to bring it within the specified tolerance.
4. Attach the squared and leveled curb to the roof structure with welds as shown in Figure 2.
5. If the curb is to be mounted on top of the roof decking, channels must be used for the full length of the curb so as not to crush the decking and possibly cause leaks. See Figure 6.

Figure 6. Curb installed on top of roof decking

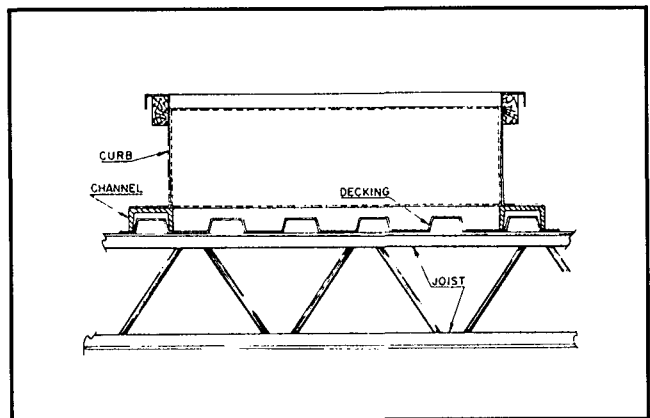

**CURB FLASHING**

1. The cross section detail in Figure 2 shows the recommended method of flashing which has been approved by the National Roofing Contractors Association.

2. Complete finished roof including counterflashing around curb must be installed prior to setting units on curb.

Table 1. Parts List

ITEM	DESCRIPTION	CURB 710058A-03		CURB 710058A-04	
		PART NUMBER	QUANTITY	PART NUMBER	QUANTITY
1	SIDE CHANNEL	713324C-01	2	713324C-01	2
2	FRONT & REAR CHANNEL	713323C-01	2	713326C-01	2
3	DIVIDER (LONG)	712443C-01	1	712443C-01	1
4	DIVIDER (SHORT)	—	—	713321C-01	1
5	3/8-16x1" HEX BOLT	000861A-00	12	000861A-00	16
6	3/8 FLAT WASHER	405003A-16	12	405003A-16	16
7	3/8 LOCKWASHER	481648A-12	12	481648A-12	16
8	3/8-16 HEX NUT	404999A-06	12	404999A-06	16

## HANDLING & RIGGING

### GENERAL HANDLING

1. To assist in determining rigging requirements, maximum model weights are shown in Table 2.

**Table 2.**

MODEL TYPE	CUR251	CUR300	CUR351
COOLING ONLY	3630	3675	3844
ELECTRIC HEAT	3730	3775	3944
GAS HEAT	4080	4125	4294
HYDRONIC HEAT	3910	3955	4124

**NOTE:** Above weights may be +10% greater depending on optional equipment selected.

2. Do not stand or walk on unit.
3. Do not drill holes anywhere in panels or in base frame of units.
4. Do not remove any access panels until unit has been installed on roof curb or field supplied structure.
5. Do not roll unit across finished roof without prior approval of owner or architect.

### RIGGING DETAILS

1. Units must be lifted by the four (4) lifting holes located at the unit base frame corners.
2. Lifting cables should be attached to the unit with shackles as shown in Figure 7.
3. The distance between the crane hook and the top of the unit must not be less than 96".
4. Four (4) spreader bars must span over the unit to prevent damage to the cabinet by the lift cables. Spreader bars for each unit must be of sufficient length so cables do not come in contact with the unit during transport.
5. Should it be necessary to store unit in a position other than on roof curb, it must be supported on two (2), 4" square rails spanning length of the unit. Unit must be stored in level position. Protect the condenser coil, as it is easily damaged.
6. Provisions for forks have been included in the unit base frame as shown. If unit is moved by fork lift truck, no other fork location is approved. Minimum fork length required is 3 ft. to prevent damage to unit.

**Figure 7.**

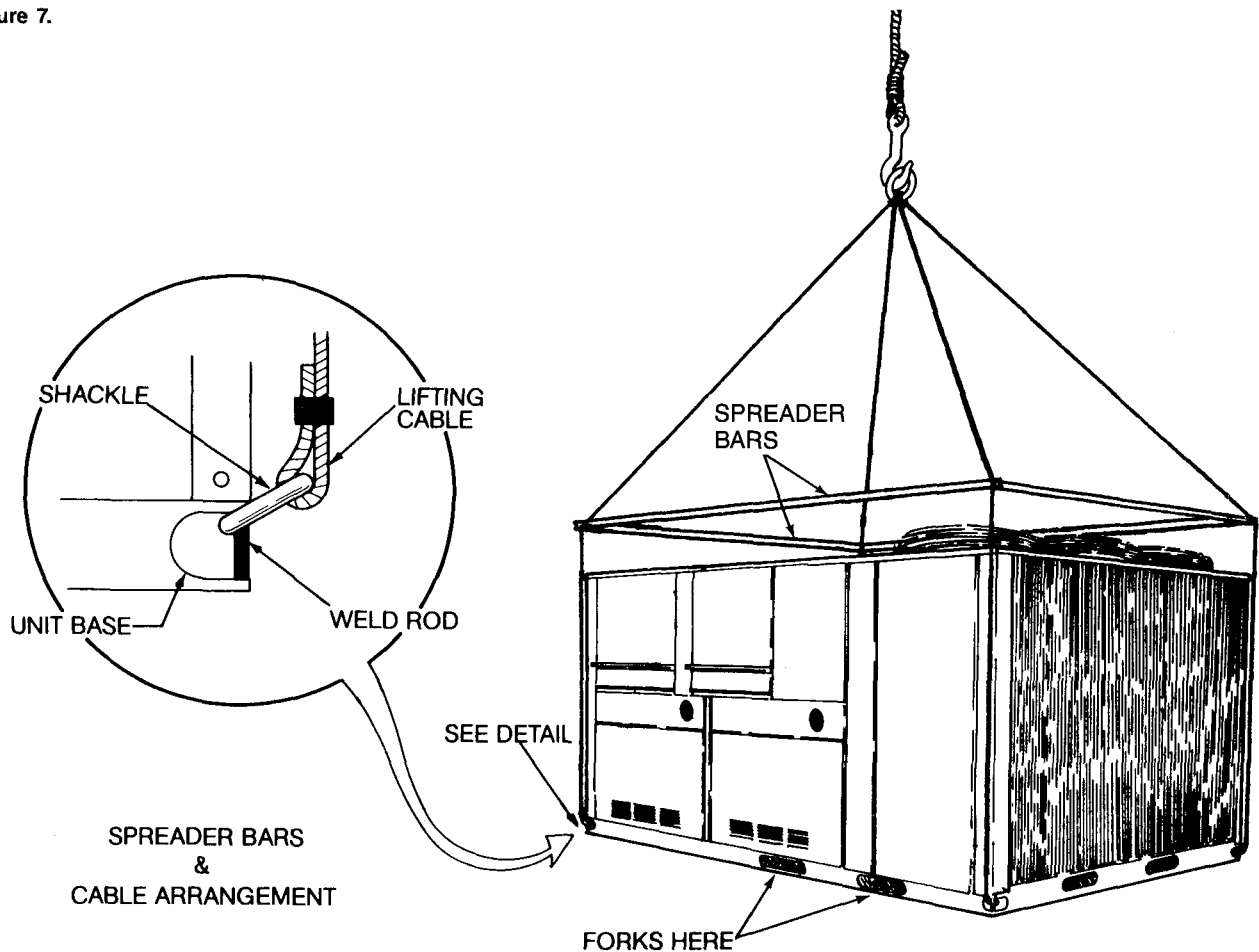

## SERVICE CLEARANCES

Adequate clearance around the unit must be kept for safety, accessibility, service and maintenance. As shown in Figure 8, 48" clearance is required at the rear (furnace and electrical) end of the unit. This clearance must be maintained for compressor removal and, in the case of a furnace unit, for removal of the furnace and to insure proper combustion air and flue gas flow. A clearance of 36" is required on the condenser side of the unit for an adequate supply of condenser air.

A clearance of 48" is recommended on the front (outside air) end of the unit for compressor removal and for adequate outside air accessibility in the event that an economizer is used with horizontal supply and return ductwork. A clearance of 96" on the filter access side of the unit is recommended for fan shaft removal. These clearances are greater than those shown on the unit dataplate. Those shown on the dataplate are minimum clearances for safety and accessibility.

### GAS HEAT UNITS

1. As shown in Figure 8 and as indicated on the unit dataplate, a minimum clearance of 48" to any combustible material is required on the furnace access side of the unit. All combustible materials must be kept out of this area.
2. This 48" minimum clearance must also be maintained to insure proper combustion air and flue gas flow. The combustion air intake and furnace flue discharge must not be blocked for any reason, including blockage by snow.
3. Adequate clearances from the furnace flue discharge to any adjacent public walkways, adjacent buildings, building openings or openable windows must be maintained in ac-

Figure 8.

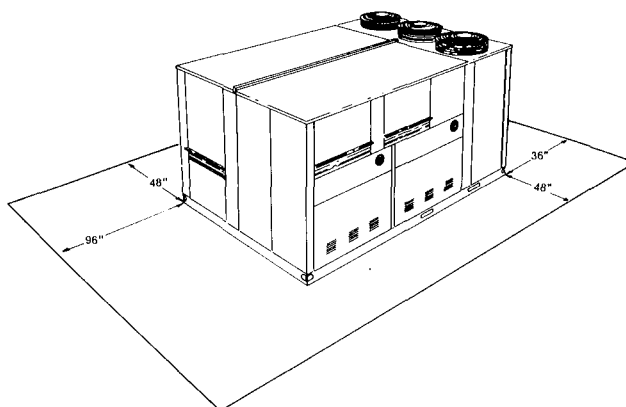

cordance with the latest edition of the National Fuel Gas Code (ANSI Z223.1) for USA and CAN/CGA B149.1 and B149.2 for Canada.

**CAUTION:** Flue gases are corrosive to certain building materials. Provide adequate clearance or other protection as required.

4. Minimum horizontal clearance of 48" from the furnace flue discharge to any electric meters, gas meters, regulators and relief equipment is required.

**NOTE:** Model CUR rooftop units are designed for outdoor installation only. They may be installed over wood flooring or over Class A, B or C roof covering materials.

## UNIT INSTALLATION ON ROOF CURB

### UNIT LOCATION

**CAUTION:** Units may look identical but have significant internal differences. Check specific unit location carefully (referring to plans if necessary) prior to setting unit.

### ISOLATOR STRIP

Check top of curb for factory installed isolator strip as shown in Figure 2. Isolator should be firmly applied to the top of each curb piece. If isolator is loose, re-apply using strong weather resistant adhesive.

### CURB INSTALLATION

Proper installation requires that the roof mounting curb be firmly and permanently attached to the roof structure. Check for adequate fastening method (welding recommended) prior to setting rooftop unit on curb.

### PROTRUSIONS

Inspect curb to insure that none of the utility services (electric, steam, hot water) routed through the curb protrude above the curb. Duct connections will normally be made after unit is set on curb. If duct is prefabricated and installed within the curb prior to setting unit, insure that ductwork does not protrude above curb. **DO NOT ATTEMPT TO SET UNIT ON CURB IF PROTRUSIONS EXIST.**

### UNIT INSTALLATION

Lower unit carefully onto roof mounting curb. While rigging unit, center of gravity will cause condenser end to be lower than supply/return air end. Bring condenser end of unit into alignment with curb. With condenser end of unit resting on curb member and using curb as fulcrum, lower front end of unit until entire unit is seated on curb.

### FASTENING SCREWS

CUR251, CUR300 and CUR351 units are provided with retaining bolts that must be secured. Bolts are field installed

Figure 9.

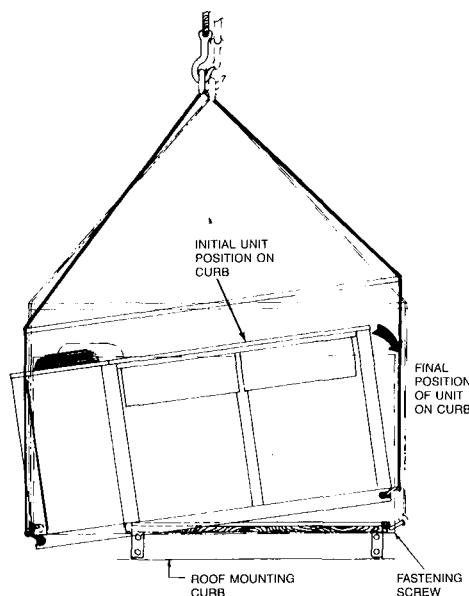

in the base frame on the end opposite the condenser. Tighten bolts until they engage flange on roof mounting curb as shown. **SCREWS MUST NOT PENETRATE ROOFING FELTS.**

### RIGGING REMOVAL

Remove spreader bars, lifting cables and other rigging equipment. **CAUTION:** DO NOT ALLOW crane hooks and spreader bars to rest on roof of unit.

# DUCT CONNECTIONS

## VERTICAL DISCHARGE

**Constant Volume Units:** Supply and return duct openings are provided in the unit base to permit vertical side-by-side duct installation after unit placement on curb. When side-by-side sheetmetal ducts are constructed in accordance with Figures 10 and 11, they are easily inserted through the unit flange and require no additional screw or rivet fasteners.

**VAV Units:** The discharge damper and, on units with power exhaust, the tracking damper prevent supply and return ducts from being connected as shown in Figure 11. It is recom-

mended that a 90° flange be turned out on each side of duct and fastened to the bottom of the unit. Seal areas where base pan is penetrated by fasteners.

**All Units:** Secure all ducts to building structure. Flexible duct connectors between unit and ducts are recommended. Insulate and weatherproof all external ductwork, joints and all roof openings with flashing and mastic in accordance with local codes. Ducts in unconditioned spaces must be insulated and covered with a vapor barrier.

**NOTE:** Duct installation before unit placement on roof curb is not recommended.

Figure 10.

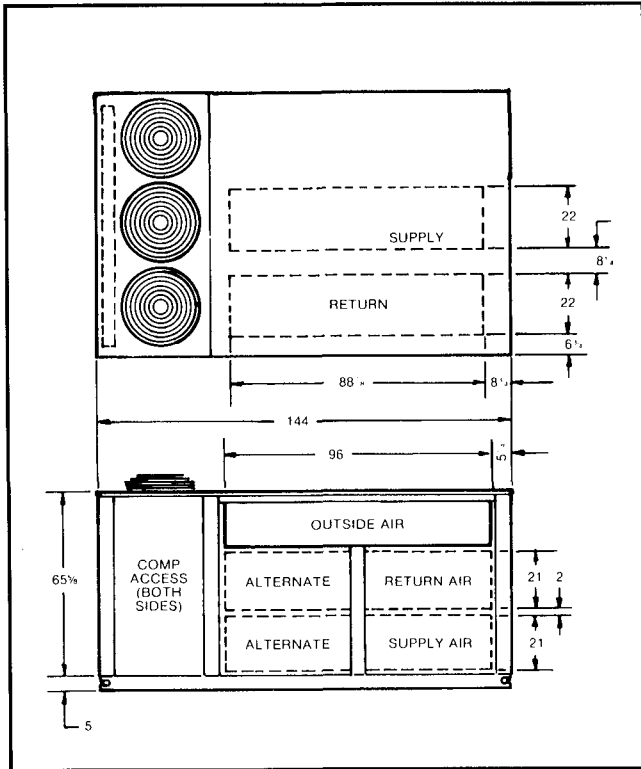

Figure 11. Typical Method for Vertical Duct Connections (CAV Units Only)

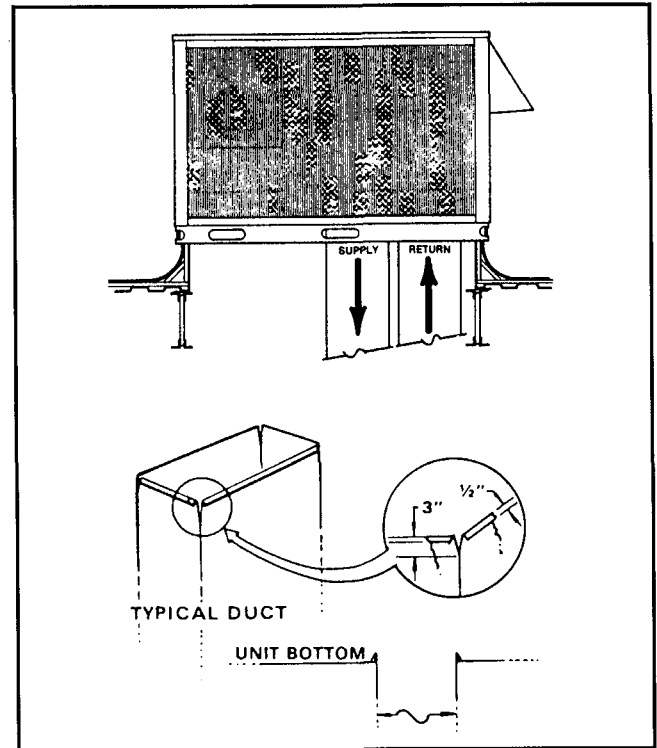

Figure 12. 710058A-03 Roof Curb (Condenser Section Overhang)

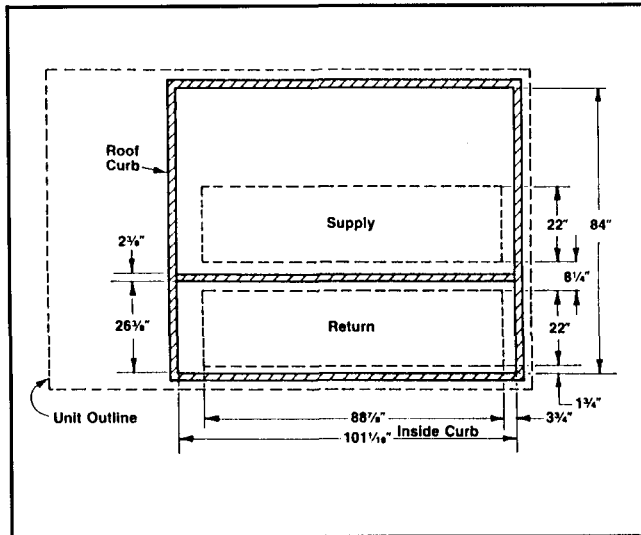
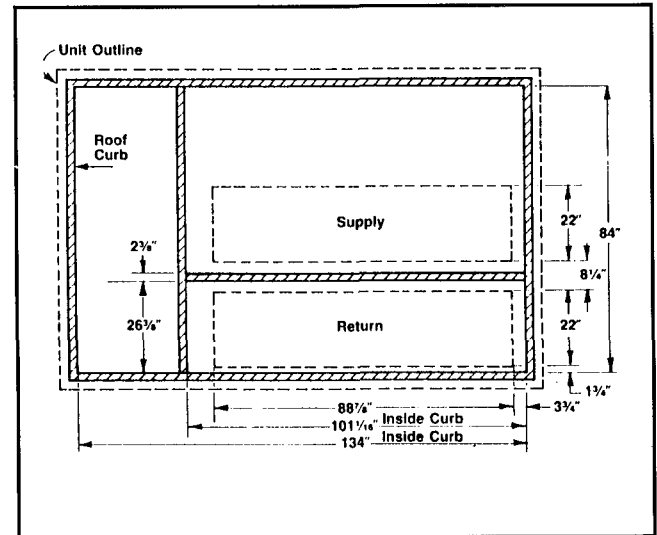

Figure 13. 710058A-04 Roof Curb (Full Perimeter Design)





## HORIZONTAL DISCHARGE DUCT CONNECTIONS WITHOUT 0 TO 100% ECONOMIZER

Optional horizontal over-under duct systems can be easily accomplished in the field on constant volume units without power exhaust or an economizer by removing the unit cabinet panels covering the duct openings, sealing the openings in the unit base with field fabricated covers and removing one internal panel. Horizontal duct openings are factory provided and units do not require field cutting.

The following steps are for field conversion:

1. Supply and return openings in base to be sealed by installing contractor (material furnished by others), Item 1.

2. Remove discharge cover assembly from position A and relocate in position B. Panel is held in place with sheetmetal screws. Facing of insulation should be free of tears.
3. Remove horizontal discharge outer cabinet panels (item 2) and discard. Connect supply and return ducts furnished by installer to supply and return openings on front of rooftop unit.

**NOTE:** When horizontal supply and return is to be used with an economizer, the unit must be ordered that way and the conversion is done at the factory. In this case, pressure relief dampers and outside air and relief air rainhoods are provided by others.

Figure 14.

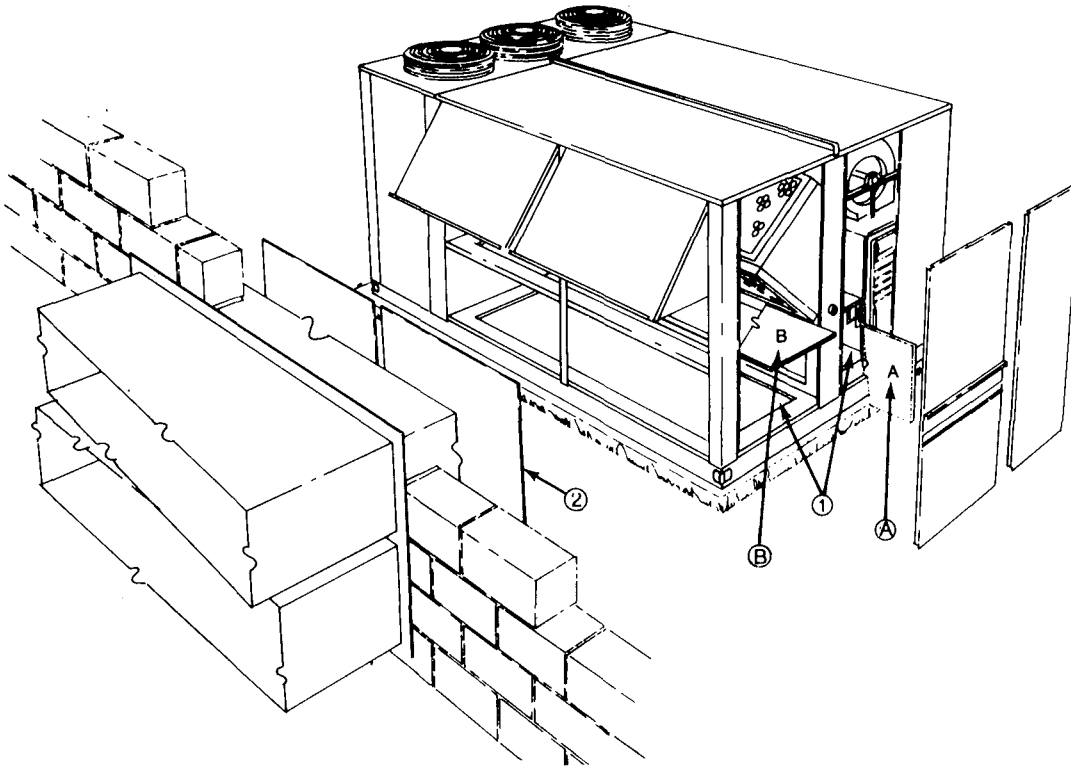

## OUTSIDE AIR INTAKE HOOD

### 25% OUTSIDE AIR MANUAL DAMPER

The outside air intake hood is factory assembled on the rooftop unit. Side hinges between the top and end plates allow the top to be collapsed for shipment. Remove and discard the shipping retainer brackets holding the intake hood. Raise the top plate; the end plates will then swing into position. Fasten the end plates to the unit using sheetmetal screws provided. Adjust the position of the slide damper located behind the outside air intake bird screen to permit intake of the desired quantity of air. Refer to Figure 15.

Figure 15. 25% Outside Air Hood

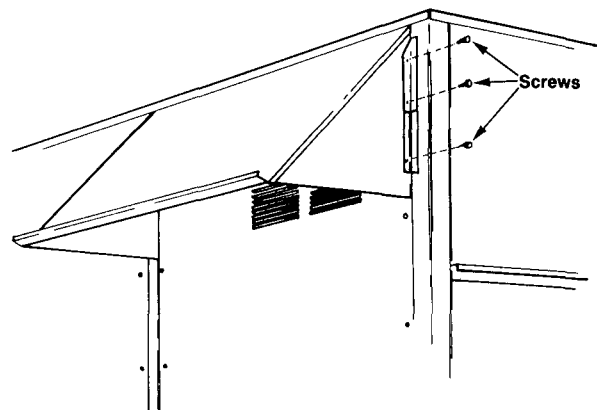

### 100% OUTSIDE AIR ECONOMIZER

The economizer outside air intake hoods are shipped collapsed similar to the 25% manual damper hood except there are two hoods, connected by a common channel. Remove and discard the shipping retainer bracket which holds the common channel against the unit. Also, remove and discard the lower retaining brackets on each end of the hoods. Do not remove the common channel. Remove the screws holding the upper retaining brackets. Lift intake hood up and swing out the hinged sides. Assemble the prefilters against the damper surface and install the filter retaining channels. The filters and channels are shipped in the condensing, heating or return air sections of the unit. **DO NOT** tighten screws. Slide sides of hoods into retaining slots and fasten with sheetmetal screws to existing retainer brackets on each side. Slide filters up so they butt against the inside of the intake hood and tighten the filter retaining channel screws. Refer to Figure 16.

### PRESSURE RELIEF DAMPER HOOD

On units without power exhaust, the pressure relief damper hoods are assembled in a similar manner as above except they do not have any pre-filters.

Figure 16. 100% Outside Air Hood

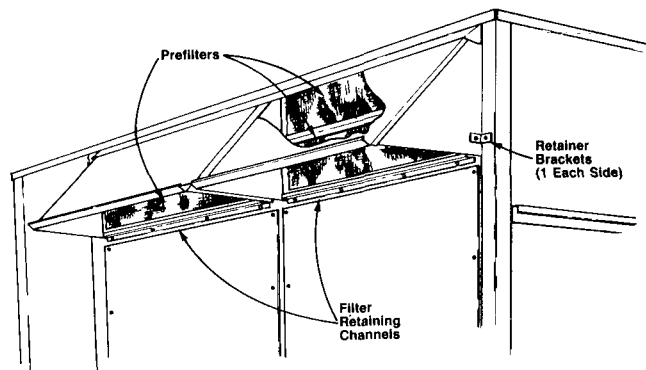

### POWER EXHAUST RAINHOOD

The power exhaust rainhoods come pre-packed in a separate carton and must be unpacked and installed on the unit. Screws are furnished with the rainhood. Refer to Figure 17.

1. Remove all parts from carton. Remove plastic from openings of exhaust blowers.
2. Install side pieces to the front panel of the rooftop unit, using holes provided. Make sure that flanges are facing each other.
3. Install bottom plate between the two side pieces.
4. Install damper blade by securing the damper between the two side pieces. **CAUTION:** Make sure that the screws are not too tight, so as to bind the damper.
5. Install the top cover over side pieces.

All other rainhoods should be assembled in the same manner.

Figure 17. Power Exhaust Rainhood

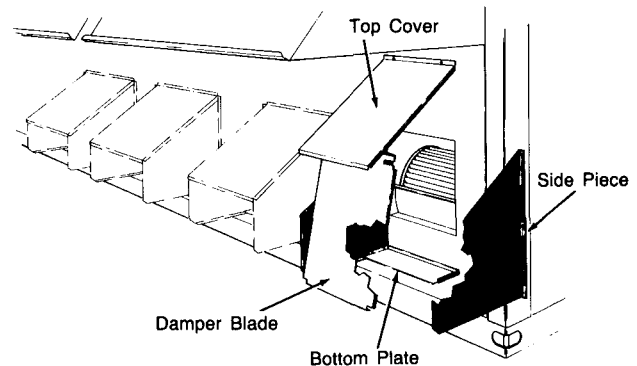

### DISCHARGE AIR DAMPER — VAV ONLY

The factory installed discharge air damper is controlled by the discharge damper motor, which is positioned by the differential pressure switch to open or close as required by supply air duct pressure. As pressure in the duct increases, the discharge air damper closes (never goes beyond 60% closed).

The differential pressure control switch is adjustable from

1.1" to 3.5" W.C., and will maintain the predetermined duct pressure by repositioning the discharge damper (supply air) in the unit, depending on pressure requirements. The duct pressure is dependent on the positioning of the various zone boxes which are responsive to their respective thermostats.

### DIFFERENTIAL PRESSURE SWITCH — VAV ONLY

If the discharge air control has been specified on the unit, there will be a differential pressure switch mounted on the unit control panel. The differential pressure switch DPS positions the discharge damper to maintain constant duct pressure at the point to which the pressure sensing tube has been routed. The following instructions should be used for locating and installing the pressure hoses.

#### INSTALLATION OF PRESSURE SENSING TUBING

Carefully select the ductwork sensing point for the pressure sensor. Improper location of the sensing point will result in unsatisfactory operation of the entire variable air volume system. The following guidelines should be adhered to:

1. Sense near the end of long duct runs to ensure that all terminal box take-offs along the run will have adequate static pressure to operate.
2. The end of the sensing tube must be perpendicular to airflow in the duct in order to sense only static pressure.
3. The sensing tube should be located in a non-turbulent flow area of the duct. Keep several duct widths away from take-off points, bends or neckdowns.
4. Should the duct be lined on the inside surface, you may use a static pressure tip such as the Dwyer A302 (furnished by installer) in place of fabricating one. It is L-shaped and should be mounted to the duct wall with the point facing the airflow.

### Materials Needed:

1. 3/8" O.D. semi-rigid plastic tubing (1/4" I.D.).
2. Teflon thread tape (to be used on all threaded connections).
3. 3/8" tubing clamps.
4. 3/8" rubber grommets.
5. 3/8" compression unions, as required.

\*Be sure that tubing complies with local code requirements. Flame retardant plastic or metal tubing may be required.

Figure 18.

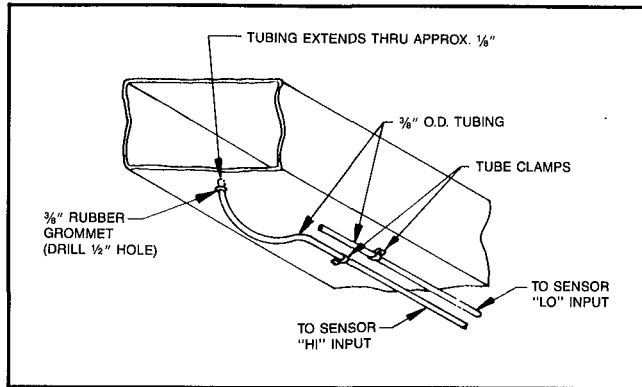

### Mounting Instructions (Refer to Figure 18)

1. Drill 1/2" hole in ductwork at the remote sensing point. The inside of the hole should be deburred.
2. Insert 3/8" rubber grommet into hole.
3. Insert sensing tube 1/8" into grommet. **Note:** The ends of the sensing tubes must be smooth and not cut on an angle. If the A302 static pressure tip is used, a 1/4" to 1/8" I.D. adapter will be required.
4. Secure firmly with tubing clamp approximately 18" back from tap point. Tubing should be bowed to eliminate sideways stresses on tubing where it enters ductwork.
5. Run tubing along ductwork and connect to "high" input of pressure switch located in the control panel.
6. An identical length of tubing should be run from the pressure switch "low" input and terminated outside the ductwork adjacent to the sensing point. **Note:** To avoid confusion between high and low tubing, it is recommended that they be of different colors.
7. Mark the location of the sensing point on the master blueprints for the building. **Note:** When tubing splices must be made, use a 3/8" compression union. **Note:** If the sensing point is to be used with fiberglass ductwork, a 6" x 6" stiffening plate must be used. The plate can be secured with duct tape run around the entire duct. Insert sensing tube until flush with inside of fiberglass duct.

### SEQUENCE OF OPERATION

The pressure switch has an adjustable setpoint (1.1" to 3.5" W.C.) and an adjustable "null band" (0.06" to 0.17" W.C. at minimum setpoint and 0.11" to 0.31" W.C. at maximum setpoint). When the sensed pressure rises above the setpoint of the pressure switch, the switch will energize the damper motor in a counterclockwise direction, moving the damper toward a more closed position until the pressure no longer exceeds the switch setpoint. When the sensed pressure falls

below the setpoint by more than the "null band span" adjustment, the switch will energize the damper motor in a clockwise direction, thereby moving the damper toward a more open position until the pressure no longer is below the switch setpoint minus the null span adjustment. The sensed pressure can vary within the null zone and no damper motor energization will occur. The null span should be wide enough so there is not excessive hunting.

Example: Pressure switch setpoint: 1.50" W.C.

Null span adjustment: 0.10" W.C.

There will be no damper repositioning when the pressure is from 1.4" to 1.5" W.C. The damper will be closing when the pressure is over 1.5" and the damper will be opening when the pressure is below 1.4" W.C.

The pressure switch is overridden when the R terminal signal is placed on terminal 21 by a night setback thermostat or the morning warm-up relay RW:

1. Relay R6 is energized which removes common signal to differential pressure switch DPS and drives discharge damper motor DD to full open.
2. When damper motor reaches full open, an auxiliary switch in motor will close placing R signal on warm-up thermostat TW which will control heat in two stages.

When the supply fan is shut down during unoccupied mode, duct pressure drops off and thus the discharge damper opens all the way. (On units with optional smoke control relay R7, the damper will be closed when the fan is off.)

### SETTING ADJUSTMENT

The factory sets the high pressure switch at 1.9" W.C. The null or low pressure switch is set at about 0.2" W.C. differential. If different settings are required, follow the instructions below:

The high actuation setpoint of the Barber-Colman PF-307 switch is indicated on a calibrated scale secured to the range screw enclosure. Resetting is accomplished by simply turning the adjustment screw with a screwdriver to the desired setting on the scale. See Figure 19.

The low actuation point is set by turning the null span adjusting screw on the top of the switch element inside the conduit enclosure. If the null switch is adjusted so that no differential can be obtained, the warranty on the unit is void due to the excessive hunting and unit cycling that will occur.

Figure 19. Differential Pressure Switch

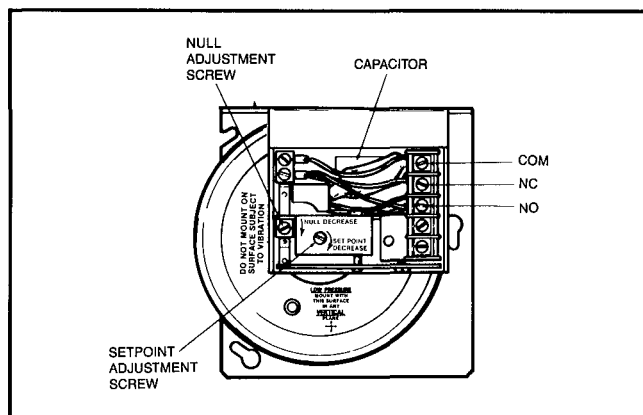

## POWER EXHAUST FAN

Optional power exhaust fans can be used in conjunction with an economizer and are factory installed. The assembly consists of two forward curved fans (CUR251) or four forward curved fans (CUR300 and CUR351) installed just behind the exhaust dampers. As more outside air is taken in, the exhaust

is switched on by a mercury bulb switch mounted on the return air damper. On VAV units, the option includes a factory installed tracking damper which is coupled to the discharge damper.

## TRACKING DAMPER — VAV ONLY

The tracking damper is designed to maintain a constant pressure in the controlled space. It is factory installed on units with power exhaust. The tracking damper is located in the return air opening of the unit and modulates with the VAV

discharge damper assembly. When one is closed, the other is closed. When the discharge damper modulates to 60% open, the tracking damper modulates to 60% open. They are both controlled by the same motor.

## ELECTRICAL INSTALLATION

### GENERAL INSTRUCTIONS

1. Electrical connections to the packaged rooftop unit consist of a main power supply, low voltage wiring to accessory thermostats, central control panels, and timeclocks.
2. All field wiring to the unit must be done in accordance with these instructions, the latest edition and addenda of the National Electrical Code, ANSI/NFPA 70 for USA and CAN/CGA B149.1 and B149.2 for Canada, and all local codes and ordinances.
3. It is recommended that an independent 115V power source be brought to the vicinity of the rooftop unit for portable lights and tools used by the service mechanic.

**WARNING: DO NOT TAMPER WITH FACTORY WIRING.** Contact your local representative or the factory if assistance is required. The internal power and control wiring of these units is factory installed and each unit is thoroughly tested prior to shipment.

### MAIN POWER WIRING

1. The main power supply for the rooftop units will be three phase, three wire. The unit is factory wired for the voltage shown on the dataplate.  
**NOTE:** If supply voltage is 208V, wire 28 must be moved from the 230V to the 208V tap on the primary of transformer TR1.
2. Main power wiring should be sized for the minimum wire ampacity shown on the dataplate.

3. An external weathertight disconnect switch, properly sized for the unit total load, is required for each unit. Fieldinstalled disconnects may be mounted in the location shown in Figure 20.

**NOTE:** Do not cover dataplate with disconnect switch.

4. The power wiring may enter the rooftop unit through the side or through the unit base and roof curbs. Install conduit connectors at the required entrance location. External connectors must be weatherproof.
5. All units must be properly grounded. The ground lug is provided for this purpose. **DO NOT** use the ground lug for connecting a neutral conductor. The unit must be electrically grounded in accordance with local codes or, in the absence of local codes, with the latest edition and addenda of the National Electrical Code, ANSI/NFPA 70 for USA and CAN/CGA B149.1 and B149.2 for Canada.
6. Power wiring should be connected to the main power terminal block located within the unit main control box.
7. Voltage to the rooftop unit must be within the voltage range indicated on the unit rating plate. Phases must be balanced within 2%. Contact local power company for correction of improper voltage or phase unbalance.

**WARNING:** Failure of unit due to operation on improper line voltage or with excessive phase unbalance constitutes product abuse and may be the cause of severe damage to unit electrical components.

Figure 20. External Wiring Routing & Entrance Location

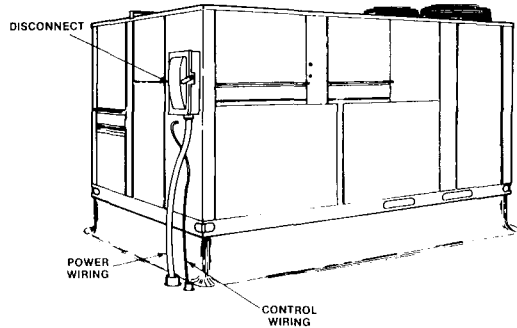

Figure 21. Through-the-curb Wire Routing

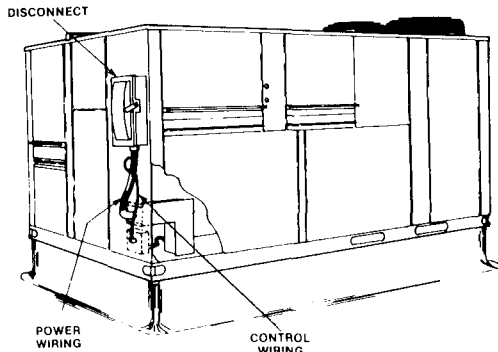
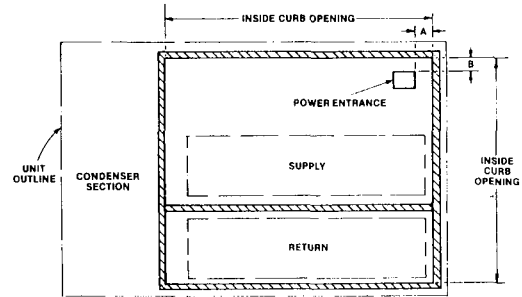
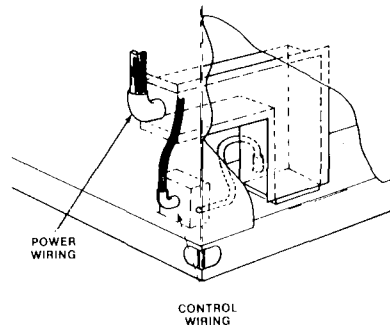

Figure 22. Plan View of Electric Entrance Locations



Cantilever curb shown. Locating dimensions are the same for full perimeter curb. Dimensions shown are in inches.

TYPE	A	B	SQUARE OPENING
COOL & ELECTRIC HEAT	5 $\frac{1}{8}$	5 $\frac{1}{8}$	3 $\frac{3}{4}$ x 3 $\frac{3}{4}$
GAS HEAT	1	1	3 x 3



## LOW VOLTAGE CONTROL WIRING — CONSTANT VOLUME UNITS

### Space Thermostat

1. A 24V accessory thermostat is required to be field installed. Thermostats may be furnished locally or purchased with the rooftop unit. Thermostats must be Honeywell Model T874 or equal, with subbase switches for "system" and "fan" as required and having the required number of heating and cooling stages, as shown in Table 3.

Table 3.

Config.	Cooling Only	Cooling With Heat		
		Nat. Gas	Propane	Electric
No. of Stages	2	2 Cool/2 Heat	2 Cool/1 Heat	2 Cool/2 Heat

2. Thermostats purchased with the rooftop unit are designed for horizontal mounting only on interior walls. Locate thermostat assembly in the conditioned space where it will sense average temperature. Do not locate the device where it would be directly exposed to supply air, sun or external sources of heat that could adversely affect its operation and the rooftop unit performance. Follow mounting instructions packaged with the thermostat.
3. Use #16 AWG wire for 24V control wiring runs not exceeding 100 ft. Use #14 AWG wire for 24V control wiring runs of 101 to 200 ft. Low voltage wiring must be NEC Class 1.
4. Route thermostat wires from subbase terminals to the rooftop unit. Control wiring should enter the unit base pan or side panel and be routed to the low voltage terminal con-

nectors as shown. Certain models are furnished with a junction box and conduit for use in routing control wiring to low voltage terminals.

### Night Setback Thermostat & Timeclock (Optional)

1. Rooftop units can be programmed for automatic start/stop operation by means of a field installed timeclock furnished either locally or purchased with the rooftop unit. A night setback thermostat may also be incorporated for reduced temperature unit control during standby periods.
2. Timeclock and night setback field wiring may be routed to the rooftop unit with the space thermostat wiring.
3. Timeclocks require a separate continuous power supply (1 phase) for operation of the timer motor. Timeclocks purchased from the rooftop manufacturer require a 120V/60Hz power supply. Power wiring for the timeclock shall conform with the temperature limitation for Type "T" wire (63°F/35°C rise).
4. Thermostats to be used for night setback may be purchased with the rooftop unit. If provided locally, they must be Honeywell Model T8034 or equal. Follow mounting instructions packaged with the thermostat.
5. Rooftop units may be optionally equipped with economizer controls that provide outside air for cooling by means of a motorized damper. When economizer controls are used in conjunction with a timeclock, a normally open set of timeclock contacts must be wired between unit terminals R and D as shown. When a timeclock (or other control) is not used, a jumper wire must be field installed between terminals R and D.

Wiring Diagram 1.

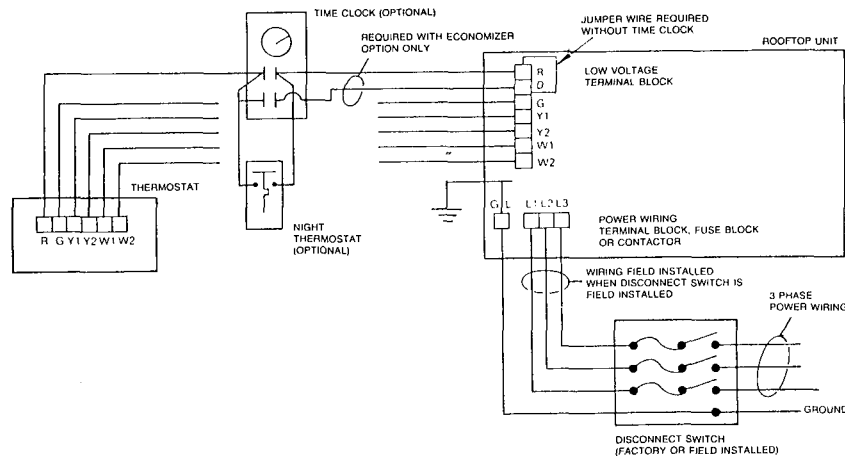
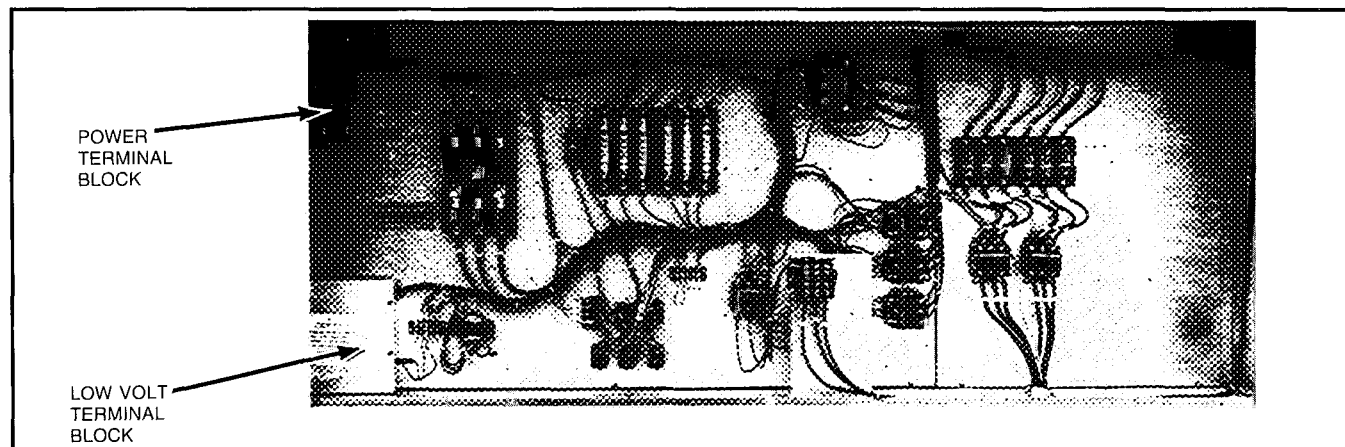

Figure 23. Typical Unit Control Panel



**Constant Volume Central Control Panels (Optional)**

1. Central control panels may be purchased for use with the rooftop unit and require field installation and wiring. Follow mounting instructions furnished with the central control panel.
2. Wiring between rooftop unit, thermostat and central control panel must be 24V NEC Class 1. Wire runs up to 100 ft. may use #16 AWG wire.
3. The number of control panel wires per unit will vary with the type of control panel selected. Table 4 is provided as

a guide and gives the maximum number of wires. It is recommended that wire bundles be made based on this quantity and unused wires be taped or cut.

**Table 4. Central Control Panel Wires**

Control Panel Type	4-Light Function Type	5-Light W/Timing Option	6-Light Function/Malfunction Type	6-Light W/Timing Option
Wires Per Station	8	9	13	14

**Figure 24. Field Wiring of Central Control Panels**

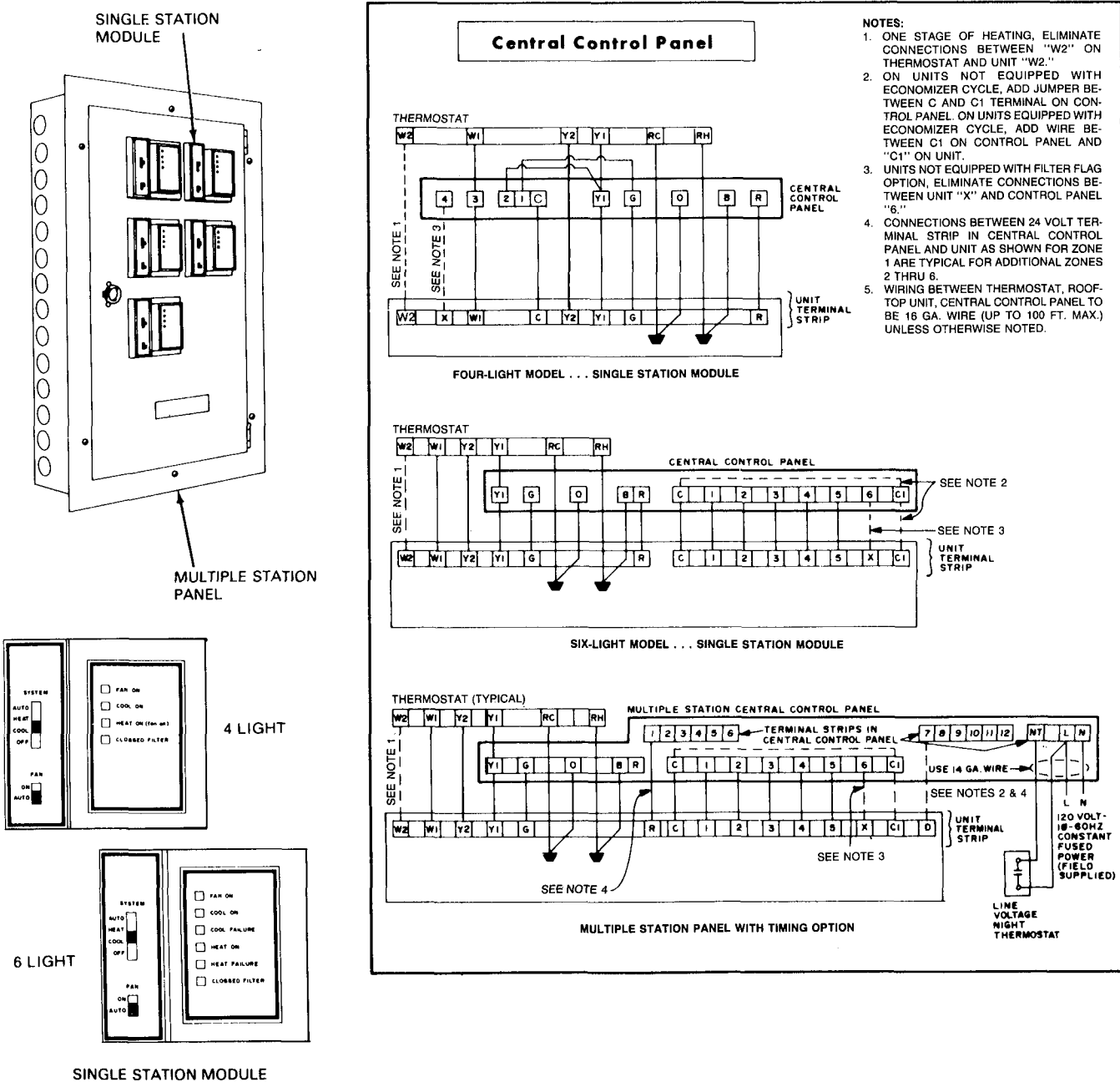

### LOW VOLTAGE CONTROL WIRING — VAV UNITS

No space thermostat is required to control the VAV unit since individual zones are controlled by their own thermostats. Control of these units is accomplished by the use of a discharge air sensor which is built into the unit at the factory.

Use #16 AWG wire for 24V control wiring runs not exceeding 100 feet. Use #14 AWG wire for 24V control wiring runs of 101 to 200 feet. Low voltage wiring must be NEC Class 1. Control wiring should enter the unit base pan or side panel and be routed to the low voltage terminal connectors as shown. Certain models are furnished with a junction box and conduit for use in routing control wiring to low voltage terminals.

#### Night Setback Thermostat & Timeclock (Optional)

1. Rooftop units can be programmed for automatic start/stop operation by means of a field installed timeclock furnished either locally or purchased with the rooftop unit. A night setback thermostat (heating only) may also be incorporated for reduced space temperature control during standby periods.
2. Timeclocks require a separate continuous power supply (1 phase) for operation of the timer motor. Timeclocks purchased from the rooftop manufacturer require a 120V/60Hz power supply. Power wiring for the timeclock shall conform with the temperature limitation for Type "T" wire (63°F/35°C rise).
3. Thermostats to be used for night setback may be purchased with the rooftop unit. If provided locally, they must be Honeywell Model T8034 or equal. Follow mounting instructions packaged with the thermostat.
4. When a night setback thermostat is used, some means of opening VAV boxes on a heating call must be provided.

#### VAV Central Control Panel (Optional)

1. VAV central control panels are equipped with a timeclock and morning warmup control circuitry. They may be purchased for use with the rooftop unit and require field installation and wiring. Follow the mounting instructions furnished with the central control panel. Refer to Wiring Diagrams 4 and 12.
2. Wiring between the rooftop unit and the central control panel must be 24V NEC Class 1. Wire runs up to 100 feet may use #16 AWG wire.
3. For VAV operation, the fan switch on the status panel should be kept in the "ON" position at all times.
4. **For status lights on panel to function, the VAV unit must be ordered with the failure relay package option.**
5. When a night setback thermostat is used, some means of opening VAV boxes on a heating call must be provided. One method is shown in Wiring Diagram 12.

Wiring Diagram 2. Manual On-Off Control

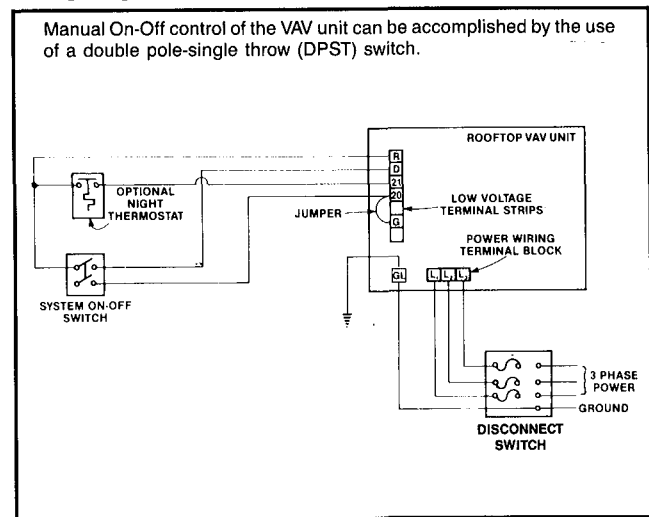

Wiring Diagram 3. Timeclock & Night Setback Control

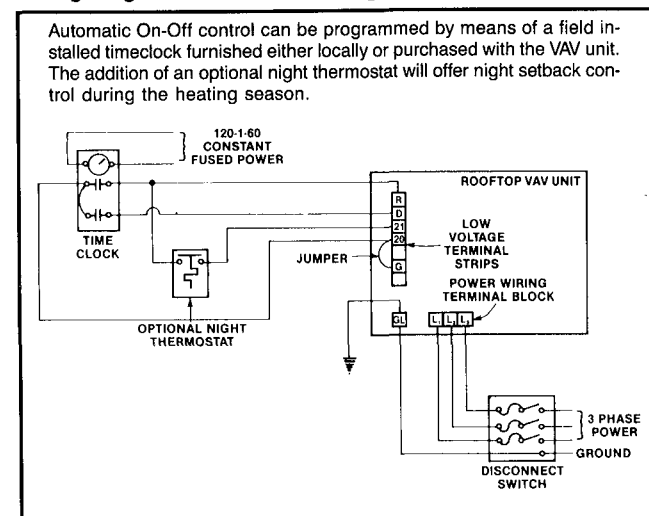

Wiring Diagram 4. Central Control Panel (Optional)

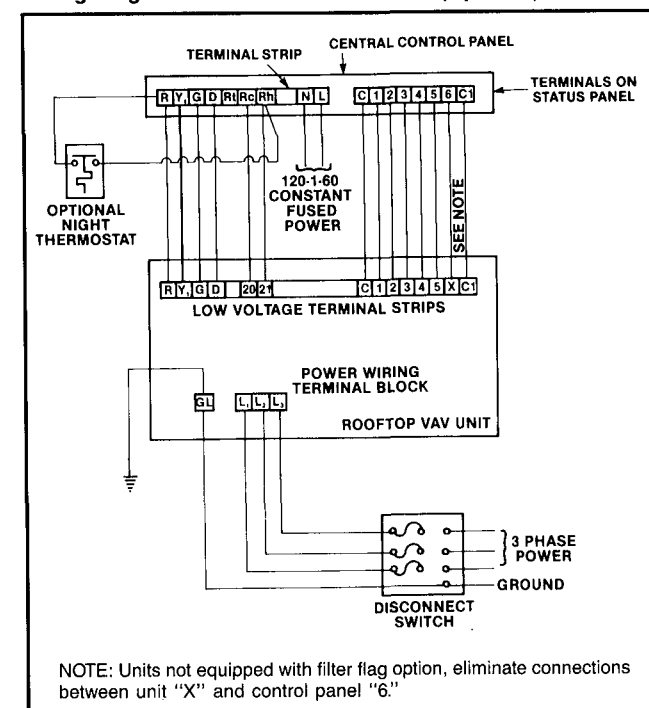

# UNIT WIRING DIAGRAMS\*

Wiring Diagram 5. CUR 300E/351E (Electric Heat, Constant Volume, 460V) — Schematic 714879D-01

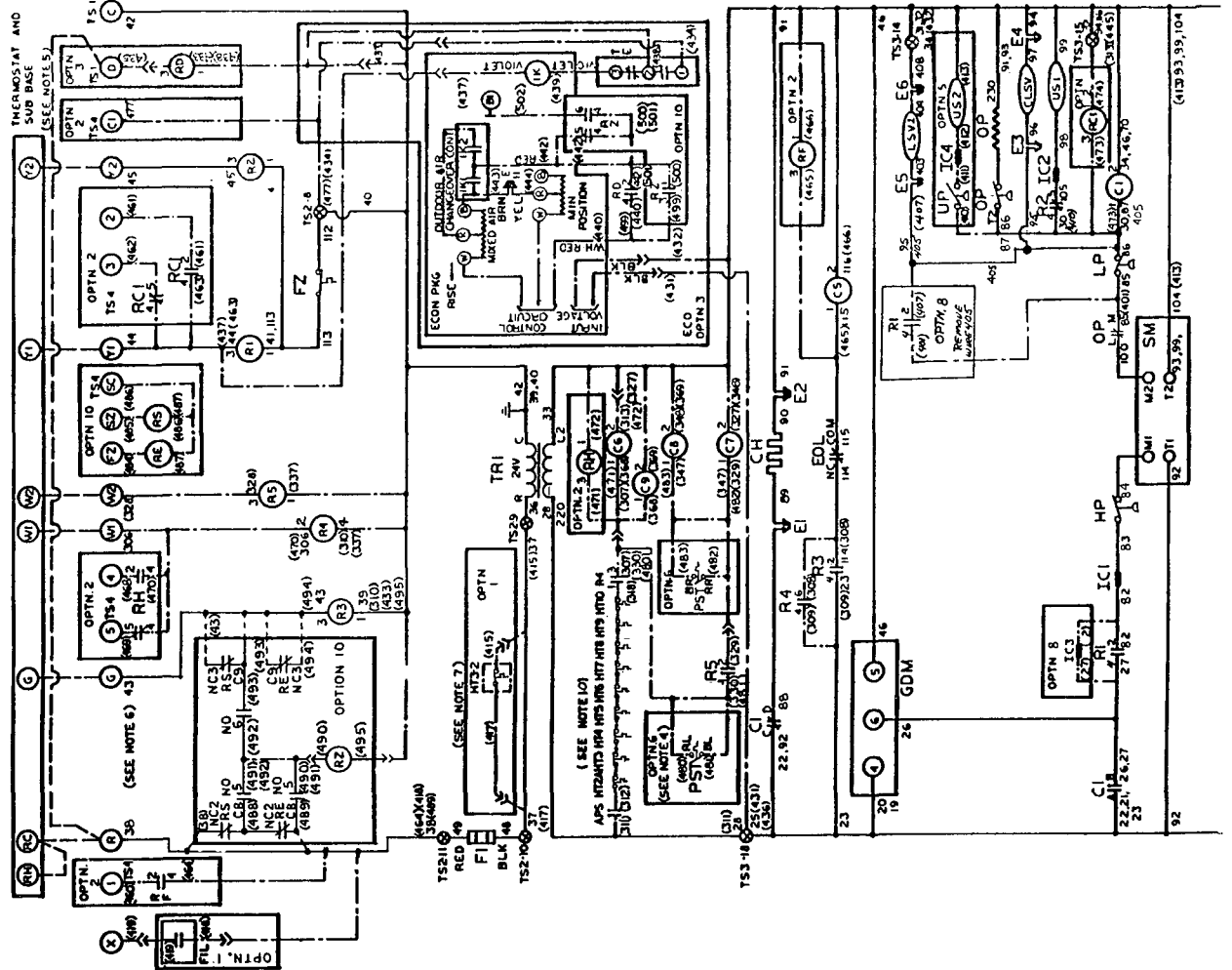

## LEGEND

- |       |   |      |                            |
|-------|---|------|----------------------------|
| APS   | AIR PRESSURE SWITCH                             | LSV  | LOW LIMIT PRESSURE SWITCH  |
| CAP   | CAPACITOR                                       | CLSV | LIQUID LINE SOLENOID VALVE |
| CM    | CRANKCASE HEATER                                | IC   | IN-LINE CONNECTOR          |
| COM   | COMPRESSOR MOTOR                                | EOL  | EMPOULATOR OVERLOAD        |
| COS   | CONDENSER PRESSURE SWITCH                       | OP   | OIL PRESSURE SWITCH        |
| ECS   | ECONOMIZER PRESSURE SWITCH                      | PS1  | POWER RETURN MOTOR         |
| EM    | EVAPORATOR MOTOR                                | R    | RELAY                      |
| F     | FUSE  | SM   | SOLID STATE MODULE         |
| FIL   | FILTER FLAG                                     | TB   | TERMINAL BLOCK             |
| FZ    | FREZZE PROTECT                                  | TE   | TEMPERATURE ELEMENT        |
| GDM   | GUARD-A-MATIC                                   | TS   | TEMPERATURE SWITCH         |
| HP    | HIGH LIMIT PRESSURE SWITCH                      | TS1  | TERMINAL STRIP             |
| HT3-2 | HIGH TEMPERATURE LIMIT SWITCH (REVERSE)         | UP   | UNLOADER PRESSURE SWITCH   |
| HT3   | HIGH TEMPERATURE LIMIT SWITCH (NORMAL)          | US   | UNLOADER SOLENOID VALVE    |
| HT4   | HIGH TEMPERATURE LIMIT SWITCH (LONG TIME)       |      |                            |
| HT5   | HIGH TEMPERATURE LIMIT SWITCH (SHORT TIME)      |      |                            |
| HT6   | HIGH TEMPERATURE LIMIT SWITCH (MEDIUM TIME)     |      |                            |
| HT7   | HIGH TEMPERATURE LIMIT SWITCH (VERY SHORT TIME) |      |                            |
| HT8   | HIGH TEMPERATURE LIMIT SWITCH (VERY LONG TIME)  |      |                            |
| HT9   | HIGH TEMPERATURE LIMIT SWITCH (VERY SHORT TIME) |      |                            |
| HT10  | HIGH TEMPERATURE LIMIT SWITCH (VERY LONG TIME)  |      |                            |
- 
- |     |                         |
|-----|-------------------------|
| --- | POWER WIRE (BLACK)      |
| --- | FLUID LINE WIRE (BLUE)  |
| --- | FIELD WIRE (RED)        |
| --- | OPTIONAL EQUIPMENT WIRE |
| --- | GROUND BY WIRE          |
| --- | WIRE NOT CONNECTED      |
| --- | PLUG CONNECTION         |

## NOTES

1. REPLACEMENT WIRE MUST BE THE SAME GAUGE AND INSULATION THICKNESS. 105 °C APPLIANCE WIRING MATERIAL.
2. ALL THREE PHASE MOTORS ARE PROTECTED UNDER PRIMARY SINGLE PHASING CONDITIONS.
3. REPLACEMENT FUSES MUST BE BUSS OR EQUIVALENT AS INDICATED IN TABLE BELOW

UNIT MODEL	R300	R351	CONTROL 24VDC/120VAC LINE		24VDC/120VAC LINE		24VDC/120VAC LINE		24VDC/120VAC LINE		24VDC/120VAC LINE	
			F1	F2	F3	F4	F5	F6	F7	F8	F9	F10
20 KW	GMD 3/20	GMD 3/20	FRS 10	FRS 10	FRS 10	FRS 10	FRS 10	FRS 10	FRS 10	FRS 10	FRS 10	JMS 30
27 KW	GMD 3/20	GMD 3/20	FRS 10	FRS 10	FRS 10	FRS 10	FRS 10	FRS 10	FRS 10	FRS 10	FRS 10	JMS 30
40 KW	GMD 3/20	GMD 3/20	FRS 10	FRS 10	FRS 10	FRS 10	FRS 10	FRS 10	FRS 10	FRS 10	FRS 10	JMS 30
47 KW	GMD 3/20	GMD 3/20	FRS 10	FRS 10	FRS 10	FRS 10	FRS 10	FRS 10	FRS 10	FRS 10	FRS 10	JMS 30
60 KW	GMD 3/20	GMD 3/20	FRS 10	FRS 10	FRS 10	FRS 10	FRS 10	FRS 10	FRS 10	FRS 10	FRS 10	JMS 30
80 KW	GMD 3/20	GMD 3/20	FRS 10	FRS 10	FRS 10	FRS 10	FRS 10	FRS 10	FRS 10	FRS 10	FRS 10	JMS 30
100 KW	GMD 3/20	GMD 3/20	FRS 10	FRS 10	FRS 10	FRS 10	FRS 10	FRS 10	FRS 10	FRS 10	FRS 10	JMS 30
120 KW	GMD 3/20	GMD 3/20	FRS 10	FRS 10	FRS 10	FRS 10	FRS 10	FRS 10	FRS 10	FRS 10	FRS 10	JMS 30
140 KW	GMD 3/20	GMD 3/20	FRS 10	FRS 10	FRS 10	FRS 10	FRS 10	FRS 10	FRS 10	FRS 10	FRS 10	JMS 30
160 KW	GMD 3/20	GMD 3/20	FRS 10	FRS 10	FRS 10	FRS 10	FRS 10	FRS 10	FRS 10	FRS 10	FRS 10	JMS 30



4. WHEN POWER SAVER OPTION IS USED, WIRES NO. 330 AND 347 ARE TO BE REMOVED.
5. WHEN ECONOMIZER OPTION IS INSTALLED, AND TIME CLOCK IS NOT USED, JUMPER WIRE MUST BE PUT BETWEEN TERMINALS "R" AND "D" ON "S-1" TERMINAL STRIP
6. WHEN SMOKE CONTROL IS ADDED TO UNIT MOVE WIRE NO. 43 FROM "R3" TERMINAL TO RS-NC3 TERMINAL.
7. WHEN FILTER-FLAG AND FIRESTAT OPTION ARE USED, WIRE NO. 37 IS TO BE REMOVED.
8. WHEN ECONOMIZER OPTION IS USED, WIRE NO. 40 IS TO BE REMOVED.
9. WHEN OPTION 8 IS PRESENT REMOVE 2240 (405) FROM CL. COIL TO 25 MDRMTR.

10. LIMIT SWITCH CONNECTIONS

NOMINAL UNIT HP	NO. OF LIMIT SWITCHES TO BE INSTALLED		CONNECTIONS TO	
	HTS	HTR	HTS	HTR
100KW	346	347	HTS	HTR
140KW	346	347	HTS	HTR
180KW	346	347	HTS	HTR
220KW	346	347	HTS	HTR
260KW	346	347	HTS	HTR
300KW	346	347	HTS	HTR
340KW	346	347	HTS	HTR
380KW	346	347	HTS	HTR
420KW	346	347	HTS	HTR
460KW	346	347	HTS	HTR
500KW	346	347	HTS	HTR
540KW	346	347	HTS	HTR
580KW	346	347	HTS	HTR
620KW	346	347	HTS	HTR
660KW	346	347	HTS	HTR
700KW	346	347	HTS	HTR
740KW	346	347	HTS	HTR
780KW	346	347	HTS	HTR
820KW	346	347	HTS	HTR
860KW	346	347	HTS	HTR
900KW	346	347	HTS	HTR

OPTIONS

- 1  FIRESTAT AND FILTER FLAG
  - 2  FAILURE RELAY PACKAGE
  - 3  ECONOMIZER (FRESH AIR CONTROL)
  - 4  POWER RETURN MOTOR
  - 5  3 rd STAGE COOLING (ADDN UNLR)
  - 11  SAFETY SMOKE CONTROL
- ELECTRIC HEAT
- A  20 KW HTR NO. 1 WIRED PER DETAIL "A" (C6)
  - B  27 KW HTR NO. 1 WIRED PER DETAIL "A" (C6)
  - C  40 KW HTR NO. 1 AND 2 WIRED PER DETAIL "A" (C6-C7)
  - D  47 KW HTR NO. 1 AND 2 WIRED PER DETAIL "A" (C6)
  - E  60 KW HTR NO. 1, 2 AND 3 WIRED PER DETAIL "A" (C6-C7)
  - F  80 KW HTR NO. 1, 2, 3 AND 4 WIRED PER DETAIL "A" (C6-C7)
  - G  100 KW HTR NO. 1, 2, 3, 4 AND 5 WIRED PER DETAIL "A" (C6-C7-C8)
  - H  120 KW HTR NO. 1, 2, 3, 4, 5 AND 6 WIRED PER DETAIL "A" (C6-C7-C8)
  - J  140 KW HTR NO. 1, 2, 3, 4, 5, 6 AND 7 WIRED PER DETAIL "A" (C6-C7-C8-C9)
  - K  160 KW HTR NO. 1, 2, 3, 4, 5, 6, 7 AND 8 WIRED PER DETAIL "A" (C6-C7-C8-C9)

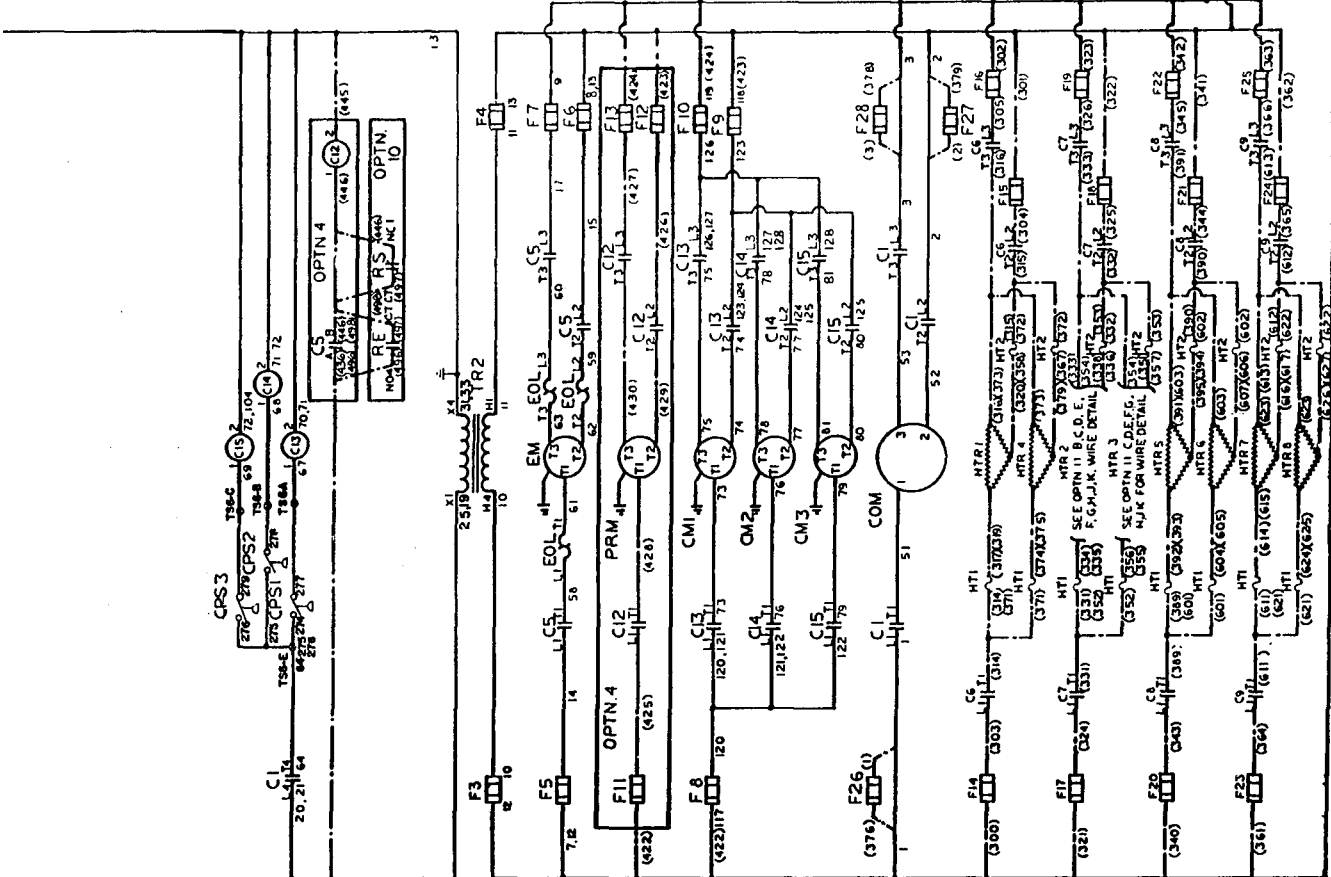
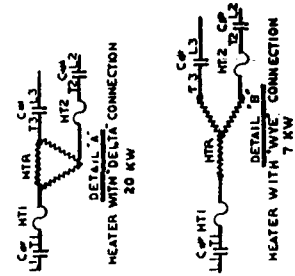



MALE PLUG  
 (307)  
 (329)  
 (313)

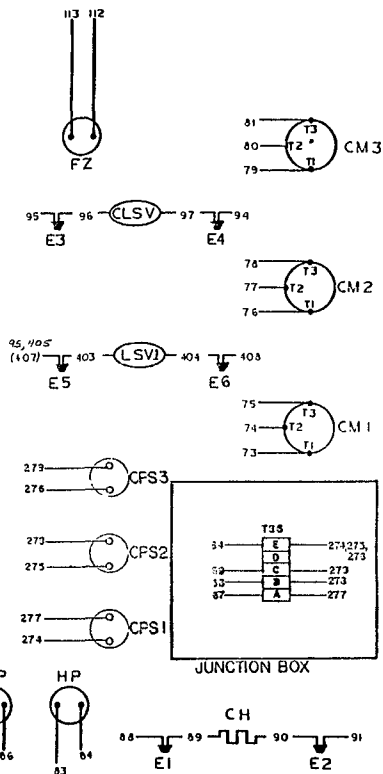
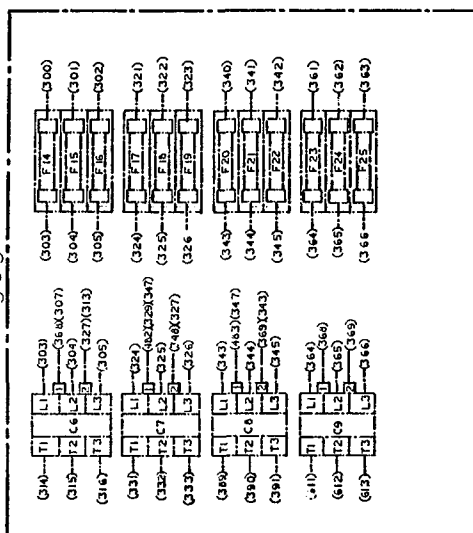

HTR NO 2  
 CONNECTED AS  
 7KW ELEMENT

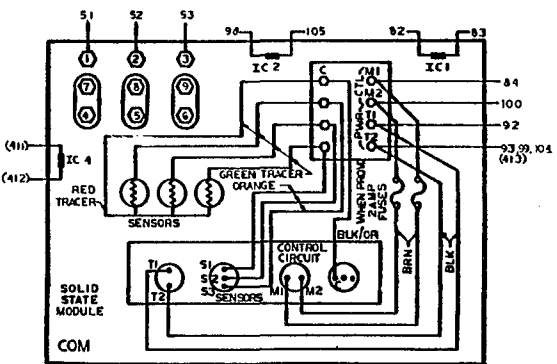
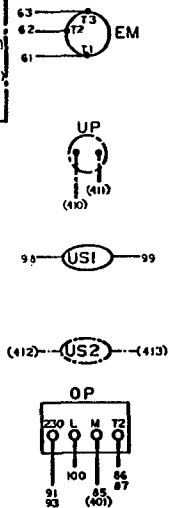
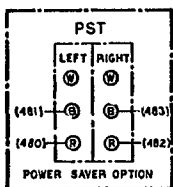





Wiring Diagram 8. CUR 300E/351E (Electric Heat, Variable Air Volume, 460V) — Practical 714888D-01

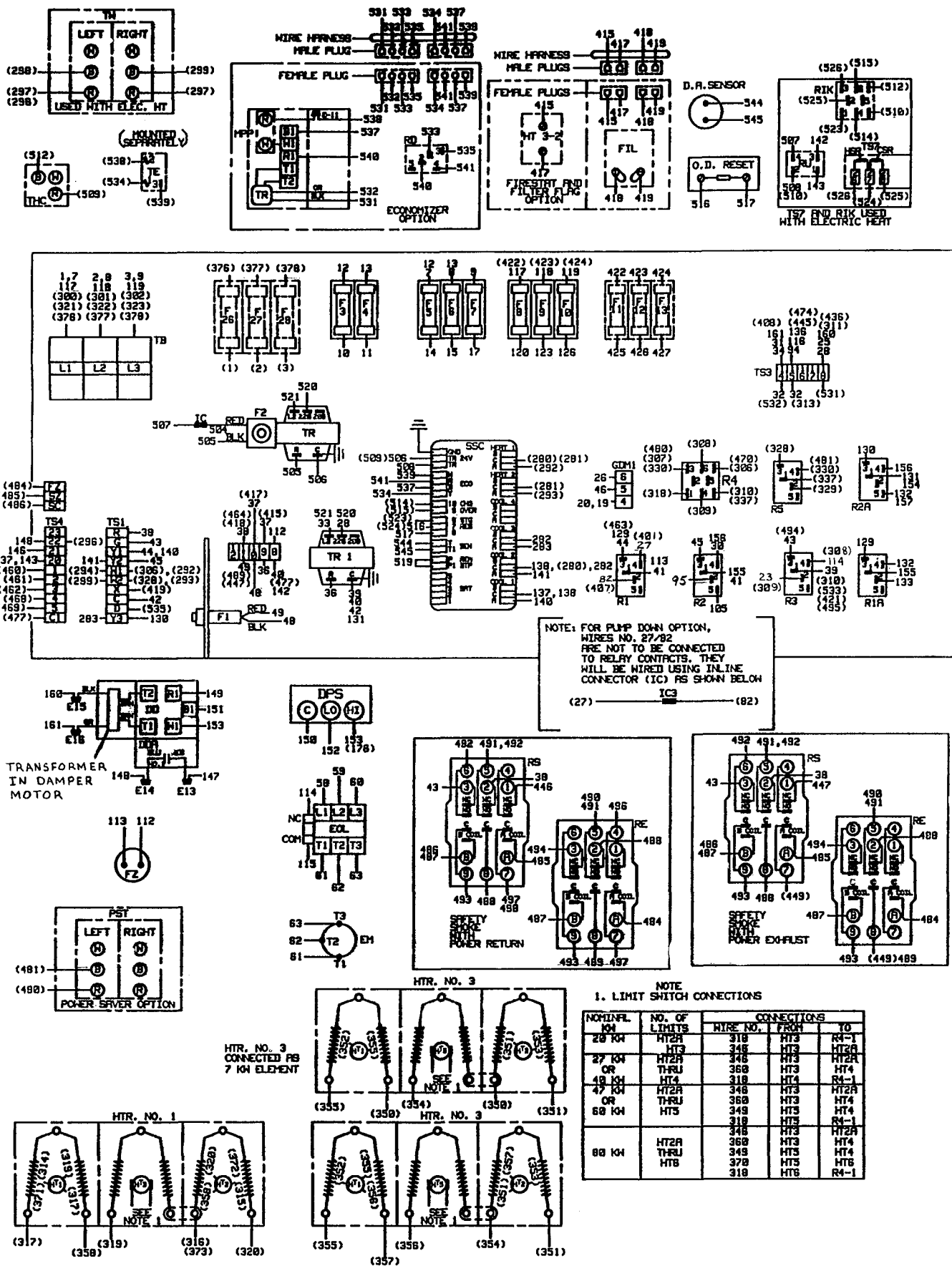

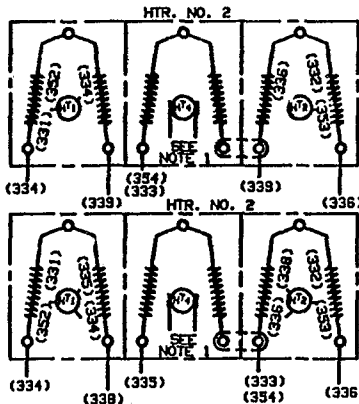
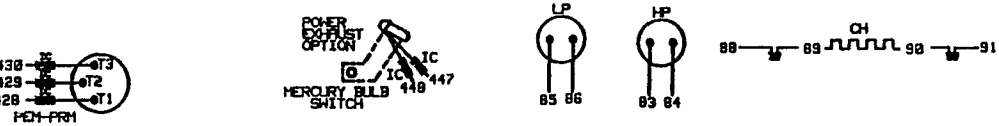
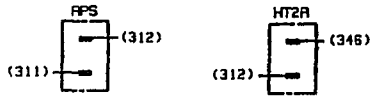
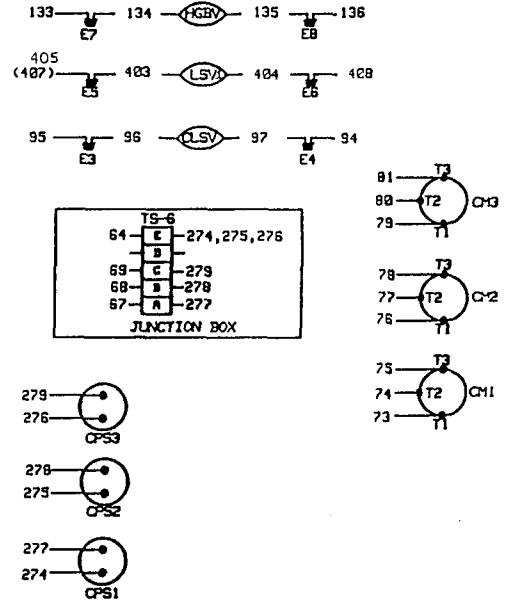
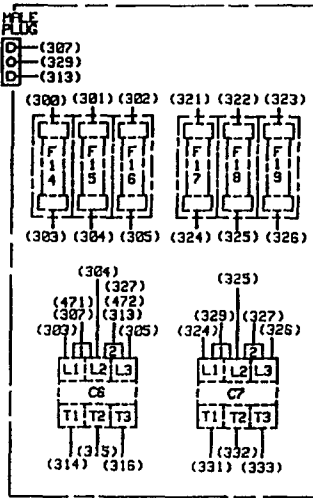
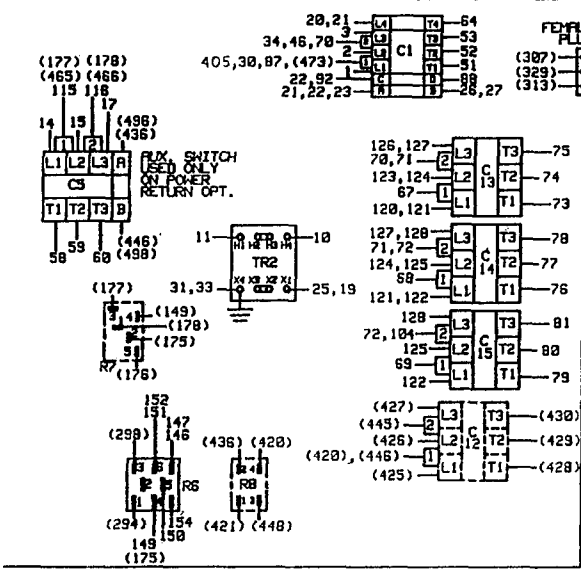
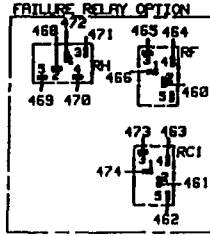
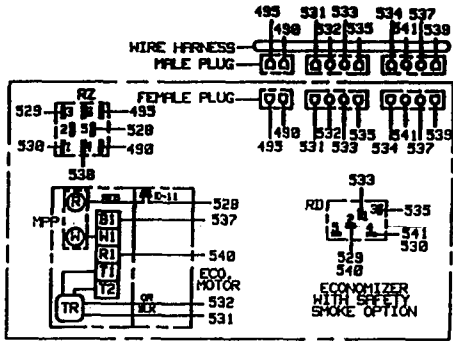

HTR, NO. 2  
CONNECTED AS  
7 KW ELEMENT

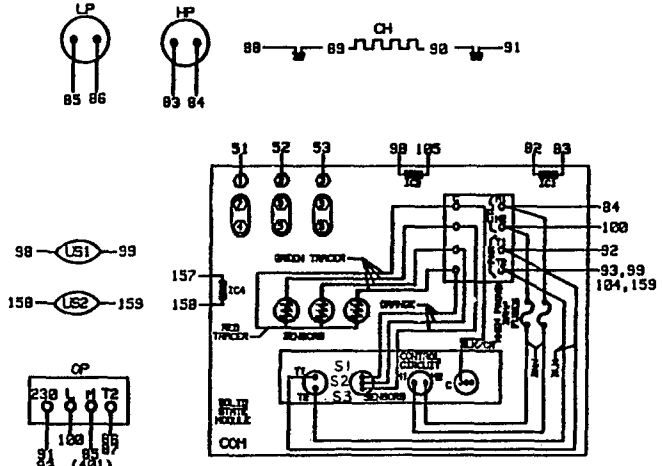

Wiring Diagram 9. CUR 300E/351E (Gas Heat, Constant Volume, 460V) — Schematic 714952D-01

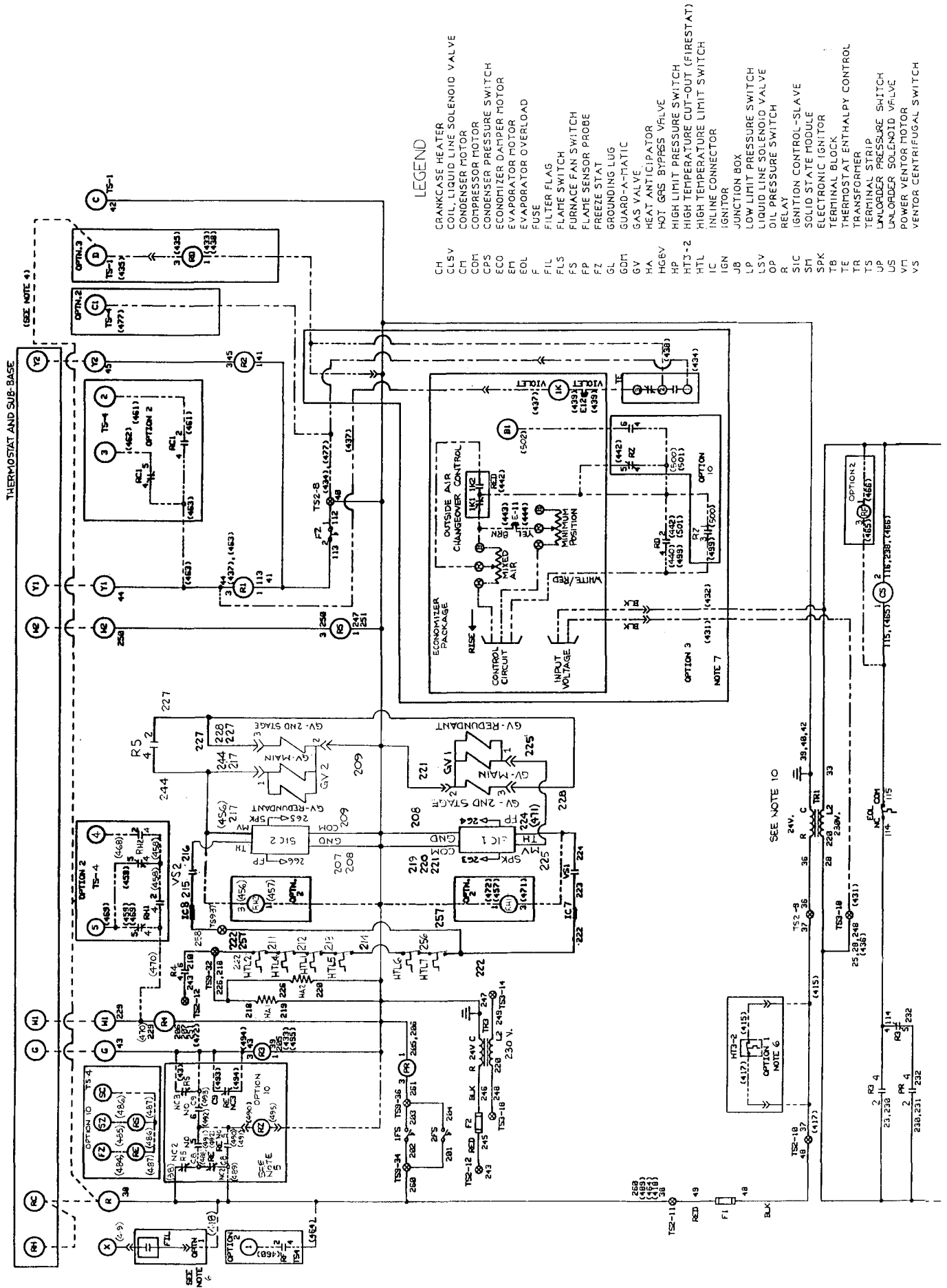



POWER WIRE  
CONTROL WIRE  
FIELD INSTALLED WIRE  
OPTIONAL EQUIPMENT WIRE  
GROUND BY WIRE  
WIRE JOINT  
WIRE NUT  
PLUG CONNECTOR  
OPTION WIRE



NOTES

- REPLACEMENT WIRE MUST BE THE SAME GAUGE AND INSULATION THICKNESS. 105 C, APPLIANCE WIRING MATERIAL.
- ALL THREE PHASE MOTORS ARE PROTECTED UNDER PRIMARY SINGLE PHASING CONDITIONS.
- REPLACEMENT FUSES MUST BE BUSS OR EQUIVALENT AS INDICATED BELOW  
 F1, F2 GND 3 2/10 24V  
 F3, F4 GND 3 460V  
 F5, F6, F7 FRS 20 460V 10 HP EM  
 F8, F9, F10 FRS 35 460V 15-20 HP EM  
 F11, F12, F13 FRS 10 460V
- WHEN ECONOMIZER OPTION IS INSTALLED AND THE CLOCK IS NOT USED JUMPER WIRE MUST BE PUT BETWEEN TERMINALS "R" AND "D" ON "TS-1" TERMINAL STRIP.
- FOR SAFETY SMOKE WITH POWER RETURN REMOVE EXISTING WIRES 38, 43 AND 446 AND DISCARD. REPLACE WITH NEW WIRES IN THE SAFETY SMOKE CIRCUIT.
- WHEN FILTER-FLAG AND FIRESTAT OPTIONS ARE USED, WIRE NO. 37 IS TO BE REMOVED.
- WHEN ECONOMIZER OPTION IS USED, WIRE NO. 40 IS TO BE REMOVED.
- REFER TO UNIT RATING PLATE FOR MAXIMUM FUSE SIZE.
- WHEN OPTION 8 IS PRESENT, REMOVE LEAD 405 FROM C1 COIL TO E5 WIRENUT.
- THE 24V TRANSFORMERS PRIMARIES ARE CONNECTED FOR 200V POWER SUPPLY. FOR 208V POWER SUPPLY DISCONNECT WIRES 28 AND 248 AND RECONNECT TO 208V TERMINAL OF THE TRANSFORMERS PRIMARY.

- OPTIONS
- 1  FIRESTAT AND FILTER FLAG
  - 2  FAILURE RELAY PACKAGE
  - 3  ECONOMIZER (FRESH AIR CONTROL)
  - 4  POWER RETURN MOTOR
  - 5  GAS SAVER
  - 6  OVERSIZED EVAP MOTOR
  - 7  PUMP DOWN
  - 8  SAFETY SMOKE CONTROL (USE WITH OPTIONS 3 AND 4 ONLY)
  - 9  3RD STAGE COOLING (ADDN UNLFP)

FIELD POWER CONNECTIONS  
(SEE NOTE 8)

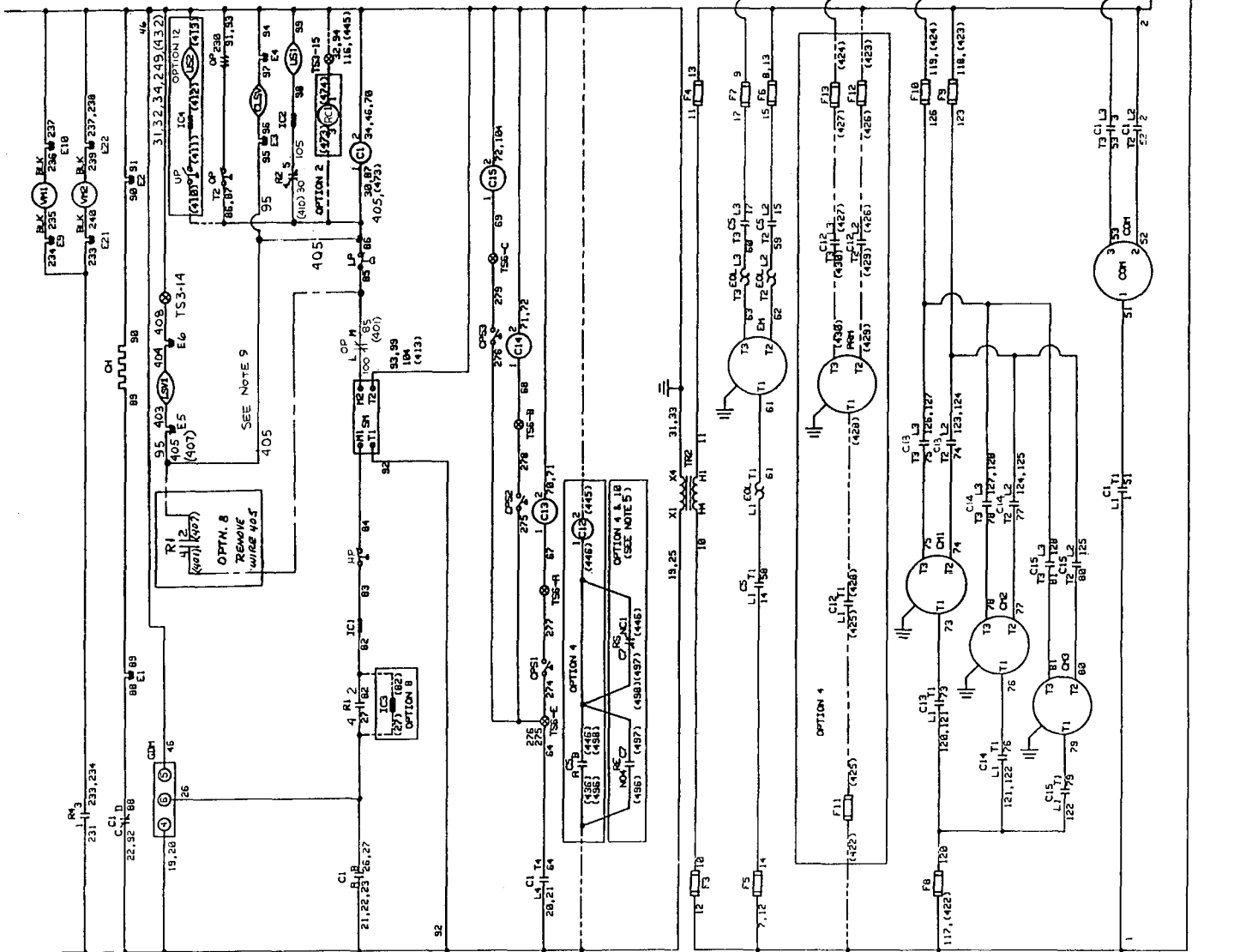

Wiring Diagram 10. CUR 300E/351E (Gas Heat, Constant Volume, 460V) — Practical 714953D-01

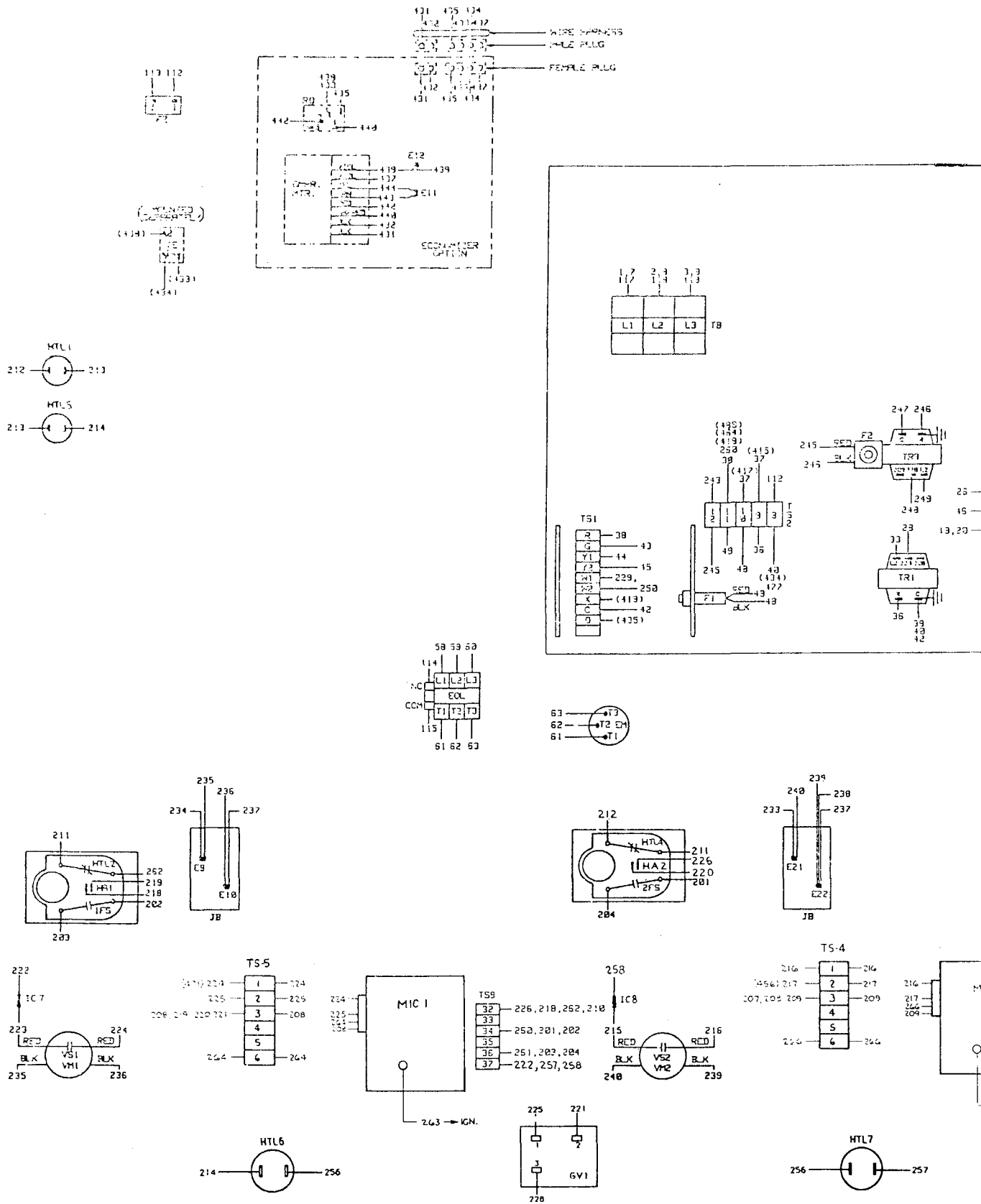

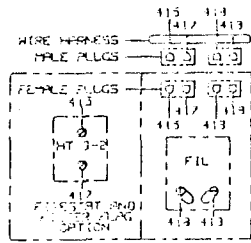

20, 21	54
34, 43, 70	53
(413), 105, 30, 47	51
32, 32	49
21, 22, 23	47, 48, 57

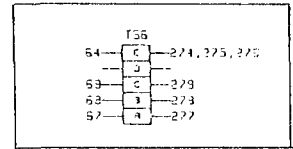
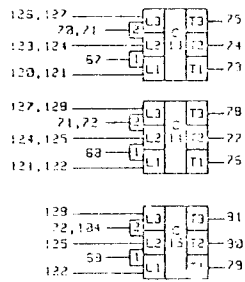
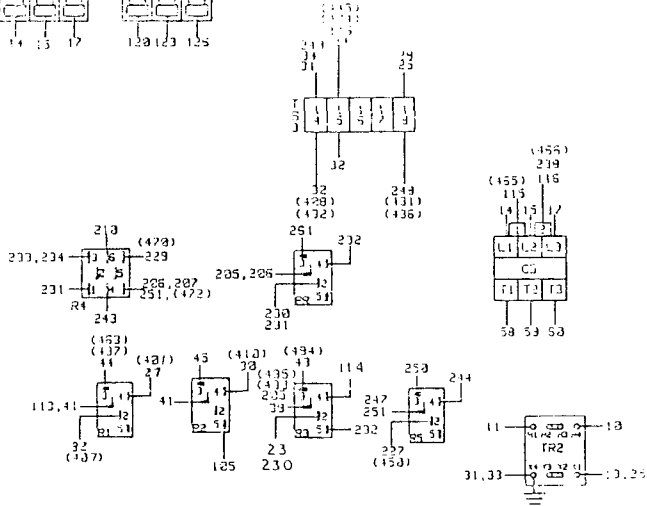
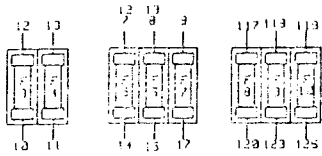

NOTE: FOR PUMP DOWN OPTION, WIRES NO. 27, 32 ARE NOT TO BE CONNECTED TO RELAY CONTACTS. THEY WILL BE WIRED USING INLINE CONNECTOR (IC) AS SHOWN BELOW

27 — IC3 — 32

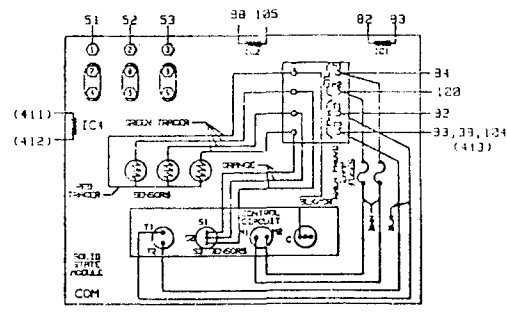
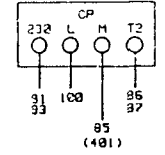
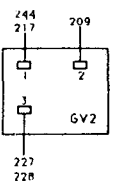
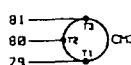
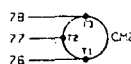
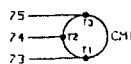
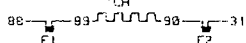
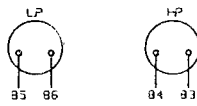
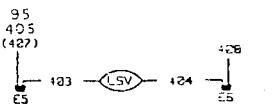
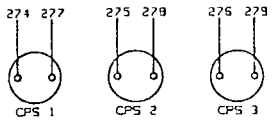
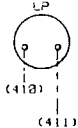

## GAS SUPPLY PIPING

### ⚠ WARNING

Improper installation, adjustment, alteration, service or maintenance can cause injury or property damage. Refer to the User's Information Manual provided with this furnace. For assistance or additional information, consult a qualified installer, service agency, or the gas supplier.

#### LOCATION AND INSTALLATION

1. The gas supply piping location and installation to the rooftop unit must be in accordance with local building codes or, in the absence of local codes, with the National Fuel Gas Code, ANSI Z223.1-1984 and Addenda, Z223.1a-1987 for USA and CAN/CGA B149.1 and B149.2 for Canada, or most recent edition and addenda.

The furnace must be electrically grounded in accordance with local codes or, in the absence of local codes, with the National Electrical Code, ANSI/NFPA 70-1987 for USA and CAN/CGA B149.1 and B149.2 for Canada, or most recent edition and addenda.

A manual gas shutoff valve must be field installed external to the rooftop unit. In addition, a ground joint union connection is required between the external shutoff valve and the unit connection to permit removal of controls for servicing.

2. All units are furnished with standard female NPT pipe connections. Connection pipe size for CUR251, CUR300 and CUR351 units is  $\frac{3}{4}$ " NPT.

The gas supply piping to the unit must be based on length of run, number of units on the system, gas characteristics, BTU requirement and available supply pressure in accordance with the latest edition and addenda of the National Fuel Gas Code (ANSI Z223.1) for USA and CAN/CGA B149.1 and B149.2 for Canada. The gas connection size at the unit does not establish the size of the supply line.

3. Rooftop units are designed for either natural gas or LP gas. Furnaces are specifically constructed at the factory for either one of these fuels and the fuels are not interchangeable in the field. Check unit dataplate to determine correct fuel.
4. Natural gas main supply pressure should be adjusted to approximately 7.0" W.C., measured at the unit gas valve. If the gas pressure at the unit is greater than 10.5" W.C., it is necessary that the contractor furnish and install an external type, positive shutoff service pressure regulator. Unit will not function satisfactorily if gas pressure is less than 5.5" W.C. or greater than 10.5" W.C.

**NOTE:** A minimum horizontal distance of 48" is required between the regulator and the furnace flue discharge.

5. LP gas main supply pressure should be at least 11.0" W.C. and must be no greater than 13.0" W.C., measured at the unit gas valve.
6. All pipe connections should be sealed with a pipe thread compound which is resistant to the furnace fuel. A soapy water solution should be used to check all joints for leaks. A  $\frac{1}{8}$ " NPT plugged tapping is available on the supply side of the gas valve for test gauge connection for reading supply (main) gas pressure. Another  $\frac{1}{8}$ " tap is available on the downstream end of the valve for checking manifold pressure. The furnace and its individual shutoff valve must be disconnected from the gas supply system during any pressure testing of that system at test pressures in excess of  $\frac{1}{2}$  psig (13.8" W.C.). The furnace must be isolated from the gas supply piping system by closing its individual manual shutoff valve during any pressure testing equal to or less than  $\frac{1}{2}$  psig.
7. There must be no obstruction to prevent the flow of combustion and ventilating air. A vent stack is not required and should never be used. The power ventor will supply an adequate amount of combustion air as long as the air passages are kept free of any obstructions and the recommended external unit clearances are maintained.

### ⚠ WARNING

Units equipped with gas heating must not be operated in an atmosphere contaminated with halogenated hydrocarbons; i.e., cleaning solvents, refrigerants, etc. Exposure to these atmospheres may cause severe damage to the gas furnace and result in improper or dangerous operation. Operation of the gas furnace in such a contaminated atmosphere constitutes product abuse and all warranty coverage by the manufacturer is void.

Figure 25. Gas Supply Piping Entrance Locations

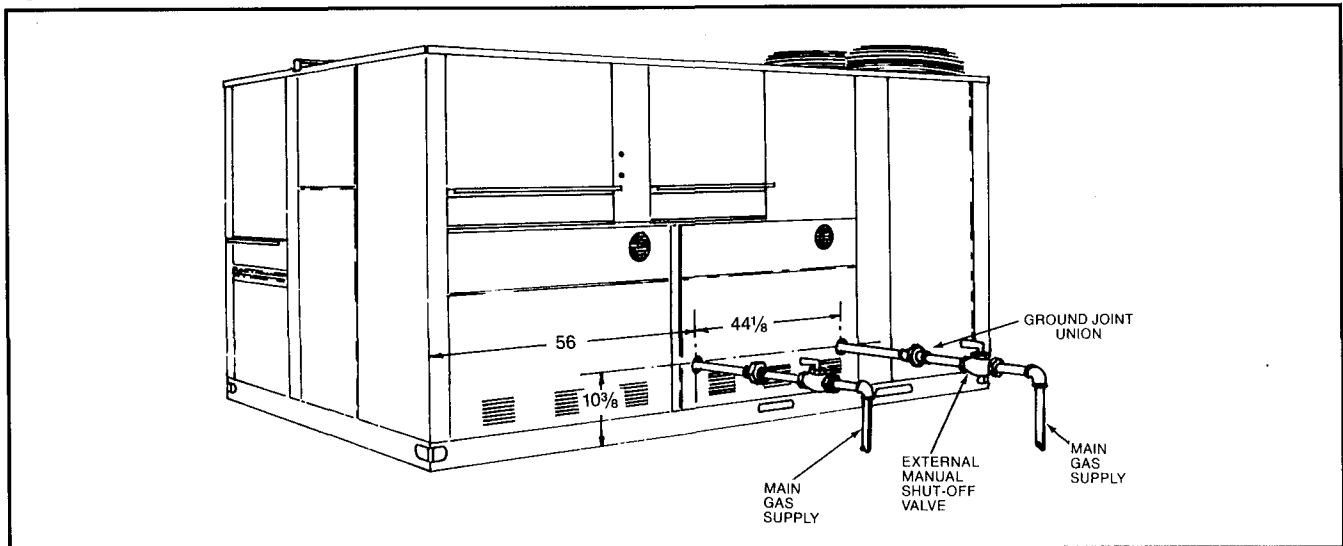

## HYDRONIC PIPING & WIRING\*

### LOCATION AND INSTALLATION

1. Units furnished with hot water or steam coils require that supply and return lines be routed inside the curb and through the bottom of the unit. External lines are not recommended due to their exposure to freezing temperatures and interference with panel removal and service.
2. Piping within the rooftop unit should be limited to only supply and return lines plus pipe unions to facilitate coil removal. All controls, service valves, balancing cocks, strainers, etc., should be located within the building.
3. Openings for supply and return lines must be field cut both in the bottom of the unit and in the roof decking. Locate openings within the shaded area indicated in Figure 26.
4. Do not employ pressurized steam return lines. Only atmospheric or vacuum steam return lines may be used. A vacuum breaker must be provided to avoid the possibility of condensate trapping.
5. Coil connection sizes for both hot water and steam are 1½ NPT.
6. Upon completion of piping installations, all pipe openings in the unit must be sealed with plastic or rubber grommet, or with caulking compound to prevent pipe chaffing and air leakage.

Figure 26. Hydronic Piping Entrance Location

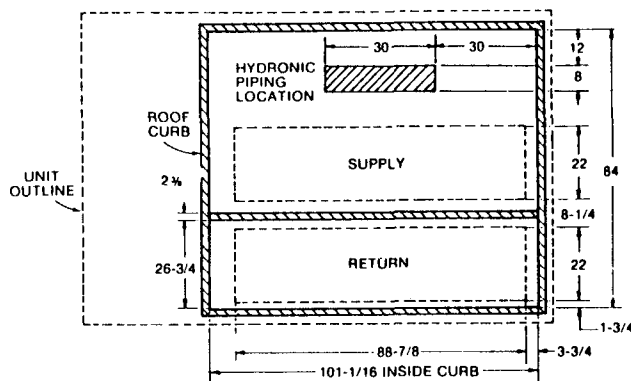

Cantilever curb shown. Locating dimensions are the same for full perimeter curb.

**CAUTION:** Water coils must be protected from freezing (glycol, draining, etc.). Coil failure and water damage which results from freezing is not the responsibility of SnyderGeneral Corporation.

### LOW VOLTAGE CONTROL WIRING

The valve and all controls required to operate it and the supply fan must be field supplied and installed. One method of controlling the fan on a constant volume unit is shown in Wiring Diagram 11.

#### NOTES:

1. Field supplied relay RH required. Additional RH contacts (not shown) may control hot water or steam valve.
2. If unit is equipped with an economizer, unit terminal D should be connected either to unit terminal R or to timeclock as shown.

#### LEGEND:

- ⊙ Field Wired To Unit Terminal
- ⊙ Field Wired To Device

----- Field Wiring

Wiring Diagram 11. Typical Method To Control Fan on Hydronic Unit

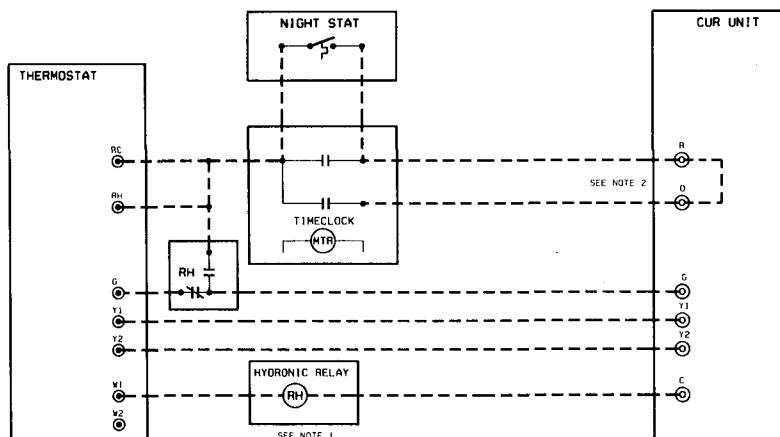

## CONDENSATE DRAIN CONNECTION

A condensate trap is provided inside the unit. Drainage of condensate directly onto the roof may be acceptable; refer to local code. It is recommended that a small drip pad of either stone, mortar, wood or metal be provided to prevent any possible

damage to the roof.

If condensate is to be piped into the building drainage system, the drain line must penetrate the roof external to the unit. Refer to local codes for additional requirements.

\*Item not submitted to ETL or CGA.

# CHECK, TEST & START PROCEDURE

## ⚠ WARNING

**ELECTRIC SHOCK HAZARD. Could cause severe injury or death. Failure to bond the frame of this equipment to the building electrical ground by use of the grounding terminal provided or other acceptable means may result in electrical shock. Disconnect electric power before servicing equipment. Service to be performed only by qualified personnel.**

### BEFORE START-UP

## ⚠ WARNING

**MOVING MACHINERY HAZARD  
DISCONNECT POWER TO THIS UNIT AND PADLOCK  
AT "OFF" BEFORE SERVICING THE FANS.**

This procedure has been prepared as a guide for the proper Check, Test & Start of the rooftop unit.

The Check, Test & Start procedure provides a step-by-step sequence which, if followed, will assure the proper startup of the equipment in the minimum amount of time. Air balancing of duct-system is not considered part of the Check, Test & Start of the rooftop unit. However, it is an important phase of any air conditioning system and should be performed upon completion of the Check, Test & Start procedure.

Rooftop units are designed for cooling operation at ambients at or above 0°F. However, the Check, Test & Start procedure at outside ambients below 55°F should be limited to a readiness check of the refrigeration system with the required final check and calibration left to be completed when the outside ambient rises above 55°F.

#### Tools Required To Perform Check, Test & Start

1. Refrigeration gauge and manifold.
2. Voltmeter.
3. Clamp-on ammeter.
4. Ohmmeter.
5. Test lead. Minimum #16 AWG with insulated alligator clips.
6. Manometer for verifying gas pressure 0 to 20" W.C.
7. Air temperature measuring device.
8. General refrigeration mechanics' tools.

#### Temporary Heating or Cooling

If it is planned that the unit will be used for temporary heating or cooling, Check, Test & Start must first be performed in accordance with this bulletin. Failure to comply with this requirement will void the warranty. New filters should be installed after the machines are used for temporary heating or cooling and the coils, fans, and motors checked for unacceptable levels of construction dust and dirt.

#### Contractor Responsibility

The installing contractor must be certain that:

- All supply and return air ductwork is in place and corresponds with installation instructions.
- All thermostats are mounted and wired in accordance with installation instructions.
- The central control panel (optional equipment) is installed and wired in accordance with installation instructions.
- All electric power, all gas, hot water or steam line connections, and the condensate drain installation have been made to each unit on the job. These main supply lines must be functional and capable of operating all units simultaneously.

#### Preliminary In Building

Prior to the beginning of Check, Test & Start procedures on the roof, the following steps should be completed in the building.

**CAUTION:** With the disconnect ON and the thermostat or Solid-State VAV Controller (SSVC) not satisfied, the machine will run. Do not start the machine until all the necessary pre-checks and tests have been performed.

1. **THERMOSTAT — CONSTANT VOLUME.** Set the thermostat in the conditioned space at a point at least 10°F below zone temperature. On cooling only models, set the thermostat system switch on COOL and the fan switch on AUTO. On heating/cooling models, set the thermostat system switch on AUTO and the fan switch on AUTO.
2. **CENTRAL CONTROL PANEL (OPTIONAL) — CONSTANT VOLUME.** On cooling only models, set the system switch on COOL and the fan switch on AUTO. On heating/cooling models, set the system switch on AUTO and the fan switch on AUTO.
3. **MANUAL ON-OFF (OPTIONAL) — VAV.** If a manual on-off DPST system switch is used, set it in the ON position.
4. **CENTRAL CONTROL PANEL (OPTIONAL) — VAV.** Set the system switch on AUTO and the fan switch on ON.
5. **TIMECLOCK (OPTIONAL).** Set the timeclock in the day or override mode. Set the timeclock on the VAV panel to the override mode only.
6. **NIGHT SETBACK THERMOSTAT (OPTIONAL).** Set thermostat at a point at least 10°F below zone temperature.

#### Check of Roof Curb Installation

The proper installation of the unit on the roof curb should be checked. Any deficiencies observed should be noted in a separate report and forwarded to the Service Dept. and the contractor. The unit and curb assembly should have been installed level. The flashing of the roof mounting curb to the roof should be checked, especially at the corners for good workmanship.

#### Check For Minimum Clearances

A minimum of 48" clearance must be provided on the main control box side of the unit. A minimum of 36" clearance is required on all other sides. A clearance of 96" is desirable on the side opposite the condenser for removal of the fan shaft.

The outside air intake must be remote from all building exhausts. The condenser air intake must be remote from all exhausts to assure full condenser capacity.

For gas heat units, check that the clearances described in the "Service Clearances" section of this bulletin have been provided.

#### Check & Report Damage

Damaged or missing parts, if any, should be itemized in a separate report stating what action has been initiated by the contractor to correct them. The absence of this information will be the basis for assuming that the unit was complete and in good condition on date of Check, Test & Start.

#### Check For Obstructions, Fan Clearance, Wiring

During the performance of the Check, Test & Start procedure you will have occasion to work in the various sections of the unit. It is important that you remove extraneous construction and shipping materials that may be found during this procedure.

All fans should be rotated manually to check for proper clearances and make certain that they rotate freely. Bolts and screws that may have jarred loose during shipment to the job-site should be checked for tightness. All electrical connections should be re-tightened.

**Pre-Startup Precautions**

It is important to your safety that the unit has been properly grounded during installation. Check ground lug connection in main control box for tightness prior to closing circuit breaker or disconnect switch.

Verify that supply voltage on line side of disconnect agrees with voltage on unit identification plate and is within the utilization voltage range as indicated in Table 5.

Table 5.\*

SYSTEM VOLTAGE	NAMEPLATE	UTILIZATION VOLTAGE	
		MIN.	MAX.
208-230/60/3	208/230	187	253
480/60/3	460	414	506
575/60/3	575	517	633

\*Full load amp rating of the motors must not be exceeded.

**SYSTEM VOLTAGE** — That nominal voltage value assigned to a circuit or system for the purpose of designating its voltage class.

**NAMEPLATE VOLTAGE** — That voltage assigned to a piece of equipment for the purpose of designating its voltage class and for the purpose of defining the minimum and maximum voltage at which the equipment will operate.

**UTILIZATION VOLTAGE** — The voltage at the line terminals of the equipment at which the equipment must give fully satisfactory performance.

Once it is established that supply voltage will be maintained within the utilization range under all system conditions, check and calculate if an unbalanced condition exists between phases. Calculate percent voltage unbalance as follows:

$$\text{③ Percent Voltage Unbalance} = 100 \times \frac{\text{② Max. voltage deviations from average voltage}}{\text{① Average voltage}}$$

GIVEN: Example — With voltage of 220, 216 and 213.

HOW TO USE THE FORMULA:

① Average voltage =  $220 + 216 + 213 = 649 \div 3 = 216$

② Max. voltage deviation from average voltage =  $220 - 216 = 4$

③ Percent Unbalance =  $100 \times \frac{4}{216} = \frac{400}{216} = 1.8\%$

Percent voltage unbalance must not exceed 2%.

**Check Field Duct Connections**

Verify that all duct connections are tight and that there is no air bypass between supply and return.

**CHECK, TEST & START PROCEDURE CONTROL SYSTEM**

**Control Voltage Check — Constant Volume**

With disconnect switch in the open (off) position, disconnect wires 39, 40, and 42 from low voltage transformer TR1.

Close the disconnect switch to energize TR1 control transformer.

Check primary (208V or 230V) and secondary (24V) of control transformer TR1.

**Control Voltage Check — VAV**

With disconnect switch in the open (off) position, disconnect wires 39, 40, 42 and 154 (CUR251) or wires 39, 40, 42 and 131 (CUR300 and CUR351) from low voltage transformer TR1.

Close the disconnect switch to energize TR1 control transformer.

Check primary (208V or 230V) and secondary (24V) of control transformer TR1.

**Thermostat Preliminary Check — Constant Volume**

With disconnect switch open and wires 39, 40 and 42 disconnected from TR1 transformer, attach one lead of ohmmeter to terminal R on TS1 terminal block. Touch, in order, the other ohmmeter lead to terminals Y1, Y2 and G at TS1 terminal block. There must be continuity from terminal R to terminals Y1, Y2 and G.

R to Y1 indicates first stage cool.

R to Y2 indicates second stage cool.

R to G indicates fan (auto).

Replace wires 39, 40 and 42 on TR1 transformer.

**VAV Field Wiring Preliminary Check — VAV**

With disconnect switch open and wires 39, 40, 42 and 154 (CUR251) or wires 39, 40, 42 and 131 (CUR300 and CUR351) disconnected from TR1 transformer, attach one lead of ohmmeter to terminal R on TS1 terminal block. Touch, in order, the other ohmmeter lead to terminals D, 20 and G at TS1 terminal block. With either the manual system switch closed or the timeclock in day mode, there must be continuity from terminal R to terminals D, 20 and G.

Replace wires 39, 40, 42 and 154 (CUR251) or 131 (CUR300, CUR351) on TR1 transformer.

**CHECK, TEST & START PROCEDURE ECONOMIZER DAMPERS & FILTERS**

**Filter Section Check**

Remove filter section access panels and check that filters are properly installed. Note airflow arrows on filter frames.

**Economizer Air Cycle Check**

Note that since economizer is controlled by outside air temperature and humidity, it may not be possible to perform these checks under certain outdoor air conditions. Refer to Table 6.

**Note:** If a power exhaust fan is provided, it should energize as return air damper closes.

**Caution:** If unit is equipped with gas heat and the inside of unit is hot (over 130°F) due to solar gain, the evaporator may be energized by the furnace fan switch. If these conditions exist, the "Evaporator Blower Fan & Power Exhaust" check, test and start procedure must be performed before the "Economizer Air Cycle Check" so that the fan may be safely operated.

**Constant Volume:** Open disconnect switch. **If there is no timeclock, install jumper wire between terminals R and D on TS1 terminal block.** In order to disable mechanical cooling, remove wire 112 from terminal 8 on TS2 terminal block. In order to disable fan, remove thermostat wire from terminal G on TS1 terminal block. Turn minimum position potentiometer to the full closed setting.

To Prove Enthalpy Control Senses High Enthalpy:

1. Set enthalpy control to the D setting.
2. Set mixed air setpoint to the minimum setting.
3. Close disconnect switch. Fresh air damper should modulate to its minimum position and return air damper should modulate open. (It may not be possible to perform this check if outdoor air enthalpy is low.)

To Prove Mixed Air Sensor Operates Dampers:

1. Set mixed air setpoint to the maximum setting.
2. Set enthalpy control to the A setting.
3. Slowly lower the setpoint temperature of the mixed air control. When the mixed air setpoint is less than the actual mixed air temperature, the outside air damper should modulate toward its open position. (It may not be possible to perform this check if outdoor air enthalpy is high. If it is, go to step 5.)

- Slowly increase the setpoint temperature of the mixed air control. When the mixed air setpoint is greater than the actual mixed air temperature, the outside air damper should modulate to its closed position. Allow damper to continue modulating to its minimum position.
- Turn minimum position potentiometer toward the full open setting. Outside air damper should modulate open.

Reset mixed air control and enthalpy control to specified setpoints. If setpoints are not specified, it is recommended that the mixed air control be set at 65°F and the enthalpy control be set at C.

Adjust and tighten damper motor and damper blade linkages.

Open disconnect switch. Replace thermostat wire at terminal G on TS1 terminal block and wire 112 at terminal 8 on TS2. Remove jumper wire from terminals R and D only when timeclock is to be used.

**VAV Units:** Open disconnect switch. On models equipped with electric heat, set changeover thermostat THC at least 10°F below return air temperature. In order to disable fan, remove field installed wire from terminal G on TS1 terminal block (refer to Wiring Diagrams 2, 3 and 4). To disable mechanical cooling, remove wire 137 from 20 on TS4 terminal block. Turn minimum position potentiometer to the full closed setting.

**Note:** The "step-and-wait" built into the SSVc will cause the full period of modulation to be several minutes.

To Prove Enthalpy Control Senses High Enthalpy:

- Set enthalpy control to the D setting.
- Set SSVc setpoint dial to 40°F.
- Close disconnect switch. Fresh air damper should modulate to its minimum position and return air damper should modulate open. (It may not be possible to perform this check if outdoor air enthalpy is low.)

To Prove SSVc Discharge Air Sensor Operates Dampers:

- Set SSVc setpoint dial to 90°F.
- Set enthalpy control to the A setting.
- Slowly lower the temperature setting of the SSVc setpoint dial. When this economizer discharge air setpoint (the setpoint dial setting minus one-half the control band setting plus any reset) is less than the actual discharge air temperature, the outside air damper should modulate toward its open position. (It may not be possible to perform this check if outdoor air enthalpy is high. If it is, go to step 5.)
- Slowly increase the temperature setting of the SSVc setpoint dial. When the economizer discharge air setpoint is greater than the actual discharge air temperature, the outside air damper should modulate toward its closed position. Allow damper to continue modulating to its minimum position.
- Turn minimum position potentiometer toward the full open setting. Outside air damper should modulate open.

Reset SSVc, enthalpy control and changeover thermostat to specified setpoints. If setpoints are not specified, it is recommended that they be set at 55°F, B, and 68°F, respectively.

Adjust and tighten damper motor and damper blade linkages.

Open disconnect switch. Replace wire 137 at terminal 20 on TS4 terminal block. Replace field installed wire at terminal G on TS1 terminal block.

### Enthalpy Control Setting

The enthalpy control is sensitive to both the temperature and humidity of the outside air entering the unit. The control has a marked scale of setting A through D. When the outside conditions exceed the setting of the control, it resets the dampers to the minimum outside air intake position.

### Economizer Fresh Air Damper Setting

The minimum position potentiometer is located on top of the economizer actuator on constant volume units, and just in-

**Table 6. Enthalpy Control Settings**

CONTROL SETTING	CONTROL POINT (°F) AT		
	20% RH	50% RH	80% RH
A	78	73	67
B	73	68	62
C	68	63	57
D	63	58	51

side the actuator cover on VAV units. It is factory set to provide 15% fresh air. Unless regulated by local codes or unusual conditions exist, a 15% fresh air setting should not be exceeded to maintain optimum heating and cooling efficiency. Determine the fresh air requirement and check position of minimum position potentiometer. Readjust if necessary. Note that 15% fresh air does not correspond to 15% of motor stroke.

## CHECK, TEST & START PROCEDURE EVAPORATOR BLOWER FAN & POWER EXHAUST

### Bearing Check

**IMPORTANT:** Prior to energizing any fans, check and make sure that all setscrews are tight so that bearings are properly secured to shafts.

### Set Evaporator Fan RPM

All evaporator motor sheaves are set at midpoint when tested and shipped from the factory. Actual rpm's must be set and verified with a tachometer. Refer to Tables 8 and 9 for basic unit fan rpm. Refer also to "Air Balancing" section for additional information.

**CONSTANT VOLUME** — With disconnect switch open, disconnect thermostat wires at terminals R and G on terminal strip TS1; this will prevent heating and mechanical cooling from coming on. Place a jumper wire across terminals R and G on TS1 terminal block. Close disconnect switch; evaporator fan motor will operate so rpm can be checked.

**VAV** — With disconnect switch open, remove wire 137 from terminal 20 on TS4 terminal block; this will prevent heating and mechanical cooling from coming on. Close disconnect switch; evaporator fan motor will operate so rpm can be checked.

### Drive Belt Tension and Alignment Adjustment

Check that the driving and driven sheaves are in alignment and that the shafts are parallel by placing a straightedge across the faces of the sheaves. There should be no gap between the straightedge and the sheaves.

Check drive for adequate run-in belt tension. Use the following procedure to determine the proper belt tension:

- Measure span length (t) in inches as shown in Figure 27.
- From Figure 27, the deflection height (h) is always  $\frac{1}{64}$ " per inch of span length (t). For example, a 32" span length would require a deflection of  $\frac{32}{64}$ " or  $\frac{1}{2}$ ".
- Determine the minimum and maximum recommended pounds force using Table 7.

Find the minimum recommended deflection force for the belt section and type based upon the small sheave diameter and drive ratio. For intermediate sheave diameters and/or drive ratio combinations, the minimum deflection force may be interpolated.

- Using a spring scale, apply a perpendicular force to any ONE of the belts at the mid point of the span as shown in Figure 27. Compare this deflection force with the values found in Step 3.
  - If the deflection force is below the minimum, the belts are too loose and the tension should be increased by increasing the center distance.
  - If the deflection force is higher than the maximum, the belts are too tight and the tension should be decreased.

When new V-belts are installed on a drive, the initial tension will drop rapidly during the first few hours. Check ten-



sion frequently during the first 24 hours of operation. Subsequent retensioning should fall between the minimum and maximum force.

To determine the deflection distance from the normal position, use a straightedge or stretch a cord from sheave to sheave to use as a reference line. On multiple-belt drives, an adjacent undeflected belt can be used as a reference.

Table 7. Recommended Pounds of Force Per Belt

BELT SECTION	SMALL SHEAVE DIAMETER (IN.)	DRIVE RATIO			
		1.0 Min.—Max.	1.5 Min.—Max.	2.0 Min.—Max.	4.0 & Over Min.—Max.
5VX	4.4	6.5—9.8	7.6—11.4	8.0—12.0	9.0—13.5
	5.2	8.0—12.0	9.0—13.5	9.5—14.3	10.0—15.0
	6.3	9.5—14.3	10.0—15.0	11.0—16.5	12.0—18.0
	7.1	10.0—15.0	11.0—16.5	12.0—18.0	13.0—19.5
	9.0	12.0—18.0	13.0—19.5	14.0—21.0	15.0—22.5
	14.0	14.0—21.0	15.0—22.5	16.0—24.0	17.0—25.5
A	3.0	2.0—3.0	2.3—3.5	2.4—3.6	2.6—3.9
	4.0	2.6—3.9	2.8—4.2	3.0—4.5	3.3—5.0
	5.0	3.0—4.5	3.3—5.0	3.4—5.1	3.7—5.6
	7.0	3.5—5.3	3.7—5.6	3.8—5.7	4.3—6.5
B	4.6	3.7—5.6	4.3—6.5	4.5—6.8	5.0—7.5
	5.0	4.1—6.2	4.6—6.9	4.8—7.2	5.6—8.4
	6.0	4.8—7.2	5.3—8.0	5.5—8.3	6.3—9.5
	8.0	5.7—8.6	6.2—9.3	6.4—9.6	7.2—10.8

Figure 27. Drive Belt Tension Adjustment

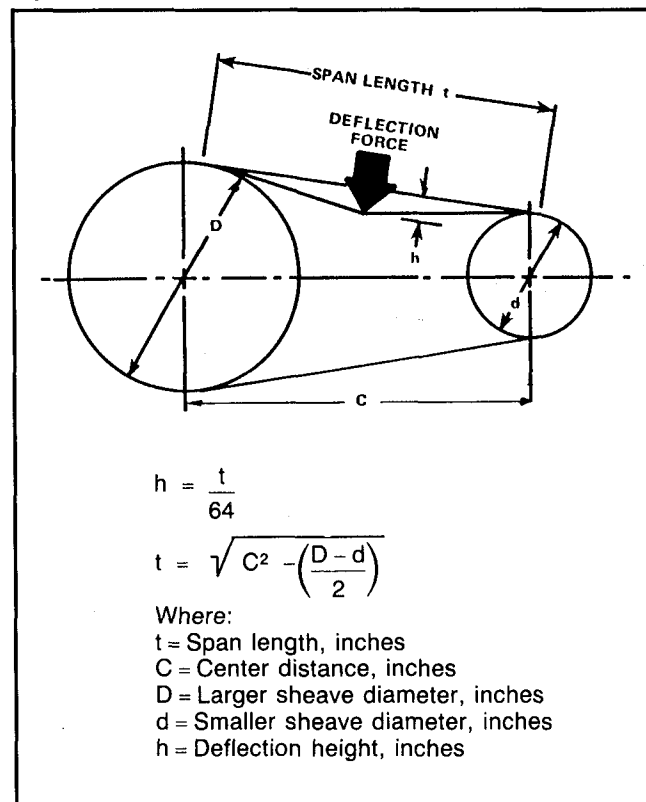

### Evaporator Fan Rotation Check

Check that fan rotates clockwise when viewed from the opposite drive side of unit and in accordance with rotation arrow shown on blower housing. If it does not, reverse two incoming power cables at TB terminal block.

Do not attempt to change load side wiring. Internal wiring assures all motors will rotate in correct direction once the evaporator fan motor rotation check has been made.

### Electrical Input Check

Make preliminary check of evaporator fan ampere draw and verify that motor nameplate amps are not exceeded. A final check of amp draw should be made upon completion of air balancing of the duct system.

### Power Exhaust (Optional Equipment)

If power exhaust option is provided, check sheave alignment and belt tension. Belt tension must not be too tight or shaft misalignment could occur.

The two power exhaust fan shafts are aligned at the factory; however, some misalignment may occur during shipping, rigging and handling procedures. If power exhaust assembly is producing excessive noise and vibration, check shaft alignment at coupling. If shafts are not aligned properly, failure of the coupling may occur. Re-align shafts by installing washer type shims as needed where the blower angle supports attach to the unit base and blower discharge panels. Make sure that coupling and sheaves are fully engaged.

When installing a 25, 30 or 35 ton rooftop unit with the power exhaust option, the installer must check the mercury activating switch. The mercury switch is installed and mounted at the factory to energize the exhaustor blower motor when the low leakage outside air damper opens 30%. If a higher percent of opening is desired, you may adjust the mercury switch by removing the mercury bulb from its holder located on the arm of the return air damper behind the filter access door. Loosen the screw that holds the mounting bracket and rotate to desired position; then retighten. Snap mercury bulb back into its holder and check to see if the desired percent has been obtained; refer to "Economizer Air Cycle Check" section above. If the percent desired has not been obtained, make further adjustment using the same procedure.

### Restoring Connections



**CONSTANT VOLUME** — With disconnect switch open, remove jumper wire from terminals R and G on TS1 terminal block, and reconnect thermostat wires at terminals R and G on TS1.

**VAV** — With disconnect switch open, replace wire 137 at terminal 20 on TS4 terminal block.

**Table 8. Supply Air Fan Performance Data**

MODEL	CFM	EXTERNAL STATIC PRESSURE -- INCHES OF WATER													
		0.4		0.8		1.2		1.6		2.0		2.4		2.8	
		RPM	BHP	RPM	BHP	RPM	BHP	RPM	BHP	RPM	BHP	RPM	BHP	RPM	BHP
CUR251	8000	620	2.7	700	3.9	780	5.0	865	6.1						
	9000	645	3.5	725	4.6	810	5.7	895	6.8						
	10000	670	4.2	760	5.3	845	6.4	930	7.5	1015	8.5	1100	9.6	1190	10.6
	11000	700	5.0	785	6.3	880	7.5	960	8.7	1040	10.0	1125	11.2	1215	12.4
	12000	730	5.9	815	7.3	910	8.5	990	9.9	1070	11.4	1150	12.8	1240	14.2
CUR300	10000	670	4.2	760	5.3	845	6.4	930	7.5	1015	8.5	1100	9.6	1190	10.6
	11000	700	5.0	785	6.3	880	7.5	960	8.7	1040	10.0	1125	11.2	1215	12.4
	12000	730	5.9	815	7.3	910	8.5	990	9.9	1070	11.4	1150	12.8	1240	14.2
	13000	785	7.2	860	8.6	955	10.0	1025	11.4	1100	12.8	1175	14.3	1265	16.1
CUR351	12000	730	5.9	815	7.3	910	8.5	990	9.9	1070	11.4	1150	12.8	1240	14.2
	13000	785	7.3	860	8.6	955	10.0	1025	11.4	1100	12.8	1175	14.3	1265	16.1
	14000	835	8.7	910	9.9	985	10.5	1060	12.8	1130	14.2	1200	15.7	—	—
	15000	895	9.3	960	11.1	1030	13.0	1100	14.6	1165	16.4	1230	18.1	—	—
	16000	955	10.2	1015	12.4	1075	14.6	1140	15.4	1200	19.0	—	—	—	—

NOTE: Allow ±5% variation in blower rpm due to pulley manufacturing tolerances.

-  Field supplied pulleys required.
-  For interpolation only. Maximum rpm=1200

**Table 9. Supply Fan RPM Range**

MOTOR HP	RPM RANGE
7½	748 to 907
10	910 to 1085
15	976 to 1178
20	1005 to 1199

Evaporator blower performance data includes internal pressure losses for cabinet, dry evaporator coil, standard throwaway filters and standard plenum. Refer to component pressure drop chart in the product catalog for data on wet evaporator coil, options and accessories.

FOR 208V, DO NOT EXCEED SERVICE FACTOR AT 1.00 (7.50 BHP FOR 7.5 HP MOTOR, 10.00 BHP FOR 10 HP

MOTOR 15.00 BHP FOR 15 HP MOTOR, AND 20.00 BHP FOR 20 HP MOTOR).

Airflow must be adjusted so that temperature rise does not exceed 65°F on electric heat units with 70°F entering air. For gas heat units the airflow must be adjusted so that the air temperature rise falls within the ranges given in the "Check, Test & Start" section of this bulletin.

**Table 10. FLA/LRA for Each Motor**

MOTOR	UNIT MODEL	MOTOR HORSEPOWER	208V/230V		460V		575V	
			FLA	LRA	FLA	LRA	FLA	LRA
EVAPORATOR MOTOR STANDARD	CUR251	7½	24.0	122	10.8	61	8.6	52
	CUR300	10	28.0	172	13.3	86	10.6	69
	CUR351	15	40.5	258	20.0	129	16.0	110
OVERSIZE EVAPORATOR MOTOR	CUR251	10	28.0	172	13.3	86	10.6	69
	CUR300	15	40.5	258	20.0	129	16.0	110
	CUR351	20	51.0	316	25.5	158	20.5	126
DOUBLE OVERSIZE EVAPORATOR MOTOR	CUR251	15	40.5	258	20.0	129	16.0	110
	CUR300	20	51.0	316	25.5	158	20.5	126
	CUR351	NA	NA	NA	NA	NA	NA	NA
CONDENSER FAN MOTOR*	CUR251, CUR300, CUR351	1½	5.6	32	2.8	16	2.2	13
POWER EXHAUST	CUR251, CUR300	3	10.0	68	5.0	34	3.6	25
	CUR351	5	15.0	96	7.3	48	5.9	40
MOTOR	UNIT MODEL	MOTOR HORSEPOWER	208/230V		460V		575V	
COMPRESSOR	CUR251	25	82	428	39.0	214	34.3	172
	CUR300	35	135	565	67.5	283	58.0	230
	CUR351	35	124	565	62.0	283	50.0	230

\*THREE (3) PER UNIT

NA = NOT AVAILABLE

## CHECK, TEST & START PROCEDURE SEQUENCER (W7100) — VAV ONLY

### Sequencer Control

The SSSVC (Solid-State VAV Control) provides on/off control of the steps of mechanical cooling available in the VAV units. Model CUR251 has two steps of cooling and Models CUR300 and CUR351 have three steps of cooling. All models have up to two steps of heating available.

The microprocessor-based W7100 discharge air controller maintains the discharge air temperature in variable air volume heating/cooling systems by modulating an economizer and sequencing stages of mechanical heating or cooling.

1. The discharge air controller is located in the main control panel.
2. The control includes the discharge air temperature setpoint adjustment (40°F to 90°F), a reset adjustment, a control band adjustment, and LED's that show which stages of cooling or heating are energized.
3. On a call for cooling, the discharge air controller will first modulate the economizer open (if outdoor enthalpy is suitable). If additional cooling is required, the SSSVC will bring it on in successive steps until the maximum amount of cooling is energized.
4. Staging is enabled when the signal from R is placed on terminal 20. The SSSVC can then energize or de-energize unit cooling through switches Cool 1A, Cool 2A and, on CUR300 and CUR351 units, Cool 3A.
5. The control band is centered (one-half of the dial setting above and one-half below) on the discharge air temperature setpoint. (This setpoint will be reduced by one-half the control band setting in economizer mode.)
6. The control band setting is adjustable from 2°F to 16°F.
7. At the end of a timing period, the microprocessor checks to see if the discharge air temperature is within the control band.
8. If it is below the control band, a stage is turned off; if it is above the control band, a stage is turned on.
9. After a switching action, a four-minute timer is reset and the microprocessor will not check the discharge air temperature again until the timing period is over.
10. If the discharge air temperature is within the control band, a 30-second timer is reset. As long as the discharge air temperature remains within the control band, the microprocessor will reset the 30-second timer.
11. If it finds the discharge air temperature outside the control band, it will make the appropriate switching action and reset the 4-minute timer.
12. The SSSVC is set up at the factory to provide reset of the discharge air temperature from outdoor air temperature. In this situation, as the outdoor temperature drops, the discharge temperature setpoint is increased by adding reset.
13. The amount of reset added to the setpoint setting varies between minimum (zero) and maximum (reset setting) as the outdoor temperature varies between 50°F and 30°F, in economizer mode, or between 90°F and 70°F, in mechanical cooling mode. If reset is not desired, terminals 6 and 7 on the SSSVC can be jumped.
14. **Recommended settings for the W7100 are 55°F on the setpoint adjustment, 10°F/40°F on the reset, and 8°F to 10°F on the control band adjustment.**

### Tempering Control (Electric Heat Units Only)

When the outdoor air temperature is low, it is possible that the discharge air temperature will be too low due to the in-

roduction of a minimum quantity of outside air for ventilation. In this situation, when the return air temperature goes below the changeover thermostat (THC) setpoint, the SSSVC will go into tempering mode and will stage on heating when the discharge air temperature is less than the SSSVC setpoint. If the outdoor temperature is less than 70°F, the discharge air setpoint will be the sum of the setpoint setting and the reset (heat) setting. The staging operation is the same as above except that, instead of a four-minute timer, a two-minute timer is reset after a switching action.

## CHECK, TEST & START PROCEDURE REFRIGERATION SYSTEM

### Preliminary Check

Make sure that hold-down bolts on compressor are secure and have not vibrated loose during shipment. Check that upper and lower vibration pads have been installed. Visually check all piping and clamps.

With disconnect switch in the "off" position, remove the electrical box cover from the compressor and check the power connections for tightness. In the event any connections have vibrated loose in shipment, extreme care must be taken to see that they are properly replaced.

The entire refrigeration system has been factory charged and tested, making it unnecessary to field charge. Factory charges are shown in Table 12 and on the unit dataplate.

**CAUTION:** Prior to startup of the refrigeration system, the compressor crankcase heaters must have been in operation for at least four (4) hours. All subsequent startups must be preceded by the same four-hour heater operation if the main power to the unit has been interrupted.

Remove seal caps from all compressor and liquid line service valves and place all valves in a back-seated position. Install service manifold hoses, and rotate valve stems one turn clockwise off backseat position. On units without optional pumpdown, gauges should read saturation pressure corresponding to ambient temperature. The following sequence check sections do not apply to units with pumpdown.

### Refrigeration Sequence Check — Constant Volume

The room thermostat has been previously set 10°F below room temperature; the system switch should still be in the "Cool" or "Auto" position and the fan switch should be in the "Auto" position.

If the unit is equipped with an economizer, set the enthalpy changeover control to the "D" setting. Remove thermostat wire or unit wire 45 from terminal Y2 on TS1 terminal block and close disconnect switch. The following operational sequence should be observed.

1. Current through primary winding of transformer TR1 energizes 24 volt control circuit; simultaneously, L1 feeds terminal 4 of solid-state protector GDM direct, and L2 feeds terminal 5 initiating the solid-state time delay cycle.
2. After a time delay of approximately 5 minutes  $\pm$  30 seconds, the system is prepared to respond to the thermostat's call for cooling.
3. When room temperature is above thermostat setting, the thermostat makes R to G and Y1, thereby energizing relay coils R1 and R3. Relay R3 contacts close energizing contactor coil C5.
4. Contactor C5 closes its contacts L1 to T1, L2 to T2, L3 to T3 to supply power to evaporator motor EM. Simultaneously, relay R1 closes its contacts to energize compressor control circuits through all safety devices, including solid-state protector contacts 4 and 6.  
Relay R2 contacts 4-5 remain in the normally closed position, thereby energizing unloader solenoid US1 allowing the compressor to start unloaded.

**CUR251 Only:** Liquid line solenoid valve LSV is energized (opened). Contacts 4-2 of relay R2 remain in the nor-

mally open position keeping coil liquid line solenoid valve CLSV closed so that refrigerant is fed to only half of the evaporator coil.

**CUR300 & CUR351:** The two liquid line solenoid valves LSV1 and CLSV open when relay R1 is energized, allowing refrigerant to flow to the entire evaporator coil.

5. Contactor C1 (and C2 on 208/230V units) makes contacts L1 to T1, L2 to T2 and L3 to T3, thereby energizing compressor motor COM.

**Note:** An anti-chatter design will lock out compressor circuits in the event of contactor chatter, and repeat the 5-minute timing cycle.

6. Contactor C1 will close auxiliary contacts A to B and open C to D. Opening C to D will de-energize crankcase heater; closing A to B will complete and maintain compressor circuits through energized relay R1.
7. Condenser fans CM1, CM2, and CM3 will be activated as required to maintain condenser head pressure through pressure switches CPS1, CPS2 and CPS3. Refer to Table 11. With all safety devices closed, system will continue the cooling operation until thermostat is satisfied.

8. Replace wire on terminal Y2 at TS1 terminal block. Second stage cooling will be energized. R to Y2 will close, energizing relay R2, opening contacts 4-5 to de-energize unloader solenoid US1.

**CUR251 Only:** Relay R2 contacts 4-2 will close to energize liquid line solenoid valve CLSV to feed refrigerant to entire evaporator coil.

9. When the thermostat is satisfied, it will break R to G, Y1 and Y2 and the above sequence of operation will be reversed. The solid-state protectors will be recycled, and the timing network will initiate the 5-minute time delay.

#### Refrigeration Sequence Check — VAV

The manual system switch should be in the "ON" position, or, in the case of a central control panel, the system switch should be in the "COOL" or "AUTO" position and the fan switch should be in the "ON" position. Set the SSVC setpoint at a point at least 10°F below the discharge air temperature. Set the enthalpy control to the "D" setting. On electric heating/cooling models, set the changeover thermostat THC at least 10°F below the return air temperature.

With disconnect switch off, remove unit wire 45 from terminal Y2 at TS1 terminal strip on all units, and wire 130 from terminal Y3 on CUR300 and CUR351 units. Close the disconnect switch and the following operational sequence should be observed.

1. Current through primary winding of transformer TR1 energizes 24 volt control circuit; simultaneously, L1 feeds terminal 4 of solid-state protector GDM direct, and L2 feeds terminal 5, initiating solid-state time delay cycle.
2. The jumper wire between terminals 20 and G allows relay R3 to be energized. Relay R3 contacts close, energizing contactor coil C5. Contactor C5 closes its contacts L1 to T1, L2 to T2, and L3 to T3 to supply power to evaporator motor EM.
3. After a time delay of approximately 5 minutes  $\pm$  30 seconds, the system is prepared to respond to the SSVC's call for cooling. (At outdoor ambients below 65°F, economizer modulation period may cause delay to be longer.)
4. If the outside air is unable to keep up with the cooling load, the discharge air temperature will rise above the SSVC control band; it then closes contact Cool 1A.

**Note:** Hot gas bypass is operated as part of the first stage of mechanical cooling. The control is set to maintain a unit suction pressure of approximately 56 psig, and is operated independently from the temperature controls

in the unit. The hot gas bypass circuit is used only when cooling demand is less than the first mechanical cooling stage capacity.

**CUR251 Only:** SSVC Cool 1A contacts close, energizing relay coils R1 and R1A. Relay R1 contacts close, energizing the compressor control circuits through all safety devices including solid-state protector contacts 4 and 6. Relay R1A contacts close, energizing the hot gas bypass solenoid valve HGBV through normally closed contacts of relay R2. Normally closed contacts of relay R2 also energize the unloader solenoid valve US1 which unloads two of the four cylinders of the compressor. The coil solenoid valve CLSV is de-energized so that refrigerant is fed to only half of the evaporator coil.

**CUR300 & CUR351:** SSVC Cool 1A contacts close, energizing relay coils R1 and R1A. Relay R1 contacts close, energizing the liquid line solenoid valve LSV and the compressor control circuits through all safety devices including solid-state protector contacts 4 and 6. Relay R1A contacts close, energizing the hot gas bypass solenoid valve HGBV through normally closed contacts of relay R2A. Normally closed contacts of relays R2 and R2A energize unloader solenoid valves US1 and US2 respectively, unloading four of the six cylinders of the compressor. The coil solenoid valve CLSV is de-energized so that refrigerant is fed to only half of the evaporator coil.

5. Contactor C1 (and C2 on 208/230V units) makes contacts L1 to T1, L2 to T2, and L3 to T3, thereby energizing compressor motor COM.

**Note:** An anti-chatter design will lock out compressor circuits in the event of contactor chatter, and repeat the 5-minute timing cycle.

6. Contactor C1 will close auxiliary contacts A to B and open C to D. Opening C to D will de-energize crankcase heater; closing A to B will complete and maintain compressor circuits through energized relay R1.
7. Condenser fans CM1, CM2 and CM3 will be activated as required to maintain condenser head pressure through pressure switches CPS1, CPS2 and CPS3. Refer to Table 11. With all safety devices closed, the system will continue the cooling operation until the SSVC is satisfied.

8. Replace wire 45 on terminal Y2 at TS1 terminal strip. The second stage cooling will be activated through SSVC switch Cool 2A.

**CUR251 Only:** SSVC Cool 2A contacts close, energizing relay coil R2. Relay R2 normally closed contacts open, de-energizing the hot gas bypass solenoid valve HGBV and de-energizing the unloader solenoid US1. All four cylinders of the compressor are now in operation and the unit is fully loaded. Simultaneously, the normally open contacts of relay R2 close, energizing the coil solenoid valve CLSV, thereby feeding refrigerant to the entire evaporator coil.

**CUR300 & CUR351:** SSVC Cool 2A contacts close, energizing relay coil R2. Relay R2 normally closed contacts open, de-energizing unloader solenoid US1, thereby loading an additional two cylinders of the compressor. Four of the six cylinders are now loaded. Simultaneously, the normally open contacts of relay R2 close, energizing the coil solenoid valve CLSV, thereby feeding refrigerant to the entire evaporator coil.

9. **CUR300 & CUR351 Units Only:** Replace wire 130 on terminal Y3 at TS1 terminal strip. The third stage of cooling will be activated through SSVC switch Cool 3A.

SSVC Cool 3A contacts close, energizing relay coil R2A. Relay R2A contacts open, de-energizing unloader solenoid US2, thereby loading an additional two cylinders of the compressor. All six cylinders are now loaded. Simultaneously, the hot gas bypass solenoid valve is de-energized.

10. When the SSSVC is satisfied, it will open Cool 3A (CUR300 and CUR351), 2A and 1A contacts, and the above sequence of operation will be reversed. The solid-state protectors will be recycled, and the timing network will initiate the 5-minute time delay.

**Note:** Depending on zone demand, the SSSVC may not cycle through all stages.

**Table 11. Condenser Pressure (Psig)**

UNIT	FAN	CUT IN	CUT OUT	LOCATION
CUR251	CM1	225	150	Fan nearest electrical access.
CUR300	CM2	250	170	Center.
CUR351	CM3	280	190	Fan furthest from electrical access.

**Table 12. Refrigerant System Charge (Lbs. R-22)**

UNIT MODEL	CHARGE (LBS.)
CUR251	32.0
CUR300	34.0
CUR351	44.0

### Expansion Valve Superheat Adjustment

It is very important that the expansion valve superheat setting be adjusted to between 8°F and 14°F. Insufficient superheat will cause liquid floodback to the compressor and possible slugging. Excessive superheat will reduce system capacity and shorten compressor life. Turn the adjusting stem clockwise to increase superheat. Adjust the stem (maximum of one turn at a time) and observe the superheat. Allow up to 30 minutes for the system to rebalance at the final superheat setting.

### Refrigeration Performance Check

Refrigeration system will be operating normally. Normal operating pressures are shown in Table 14. Check that compressor FLA corresponds to values shown in Table 10. FLA draw can be as much as 25% less than values in Table 10 at low load conditions and low ambient condensing temperatures. Values in Table 10 can be exceeded when ambient temperature is above 104°F.

Check liquid sightglass. Glass should be full and clear at full load conditions.

Check oil level in compressor crankcase. Level should be at center of sightglass (approximate).

**Constant Volume:** Remove wires 45 and 44 from terminals Y2 and Y1, respectively, at TS1 terminal block. Allow refrigeration system to shut down normally and then open disconnect switch. Reconnect wires to terminals Y2 and Y1. Set thermostat and enthalpy changeover control to desired setpoints.

**VAV:** Remove wires 45 and 44 from terminals Y2 and Y1, respectively, at TS1 terminal strip (CUR251) and wires 130, 45 and 44 from terminals Y3, Y2 and Y1, respectively (CUR300 and CUR351). Allow refrigeration system to shut down normally and then open the disconnect switch. Reconnect wires to terminals Y3 (CUR300 and CUR351), Y2 and Y1. Reset SSSVC, enthalpy control and changeover thermostat (if used) to specified setpoints. If setpoints are not specified, 55°F, "B" and 68°F, respectively, are recommended.

**Table 13. Refrig. System Subcooling & Superheat Values**

Subcooling at Condenser Outlet	2°F to 8°F*
Superheat at Thermal Expansion Valve Bulb	8°F to 14°F*

\*Values based on standard operating conditions of 95°F condenser ambient, 400 cfm/ton at 80°F DB and 67°F WB.

**Table 14. Refrig. System — Normal Operating Pressures**

SYSTEM PRESSURE (PSIG)	CONDENSING AMBIENT (°F)			
	65	75	95	115
Suction	50 to 90			
Discharge	200	240	305	380

### CHECK, TEST & START PROCEDURE

#### DIFFERENTIAL PRESSURE SWITCH — VAV ONLY

Set the pressure controller (DPS) to the desired static pressure by observing the calibrated scale secured to the range screw enclosure.

Connect a voltmeter across wires 152 and 153, making sure the meter is set to read up to 30 VAC. A reading of zero volts indicates that the motor is not driving. A reading of 28 volts (approximate) indicates that the motor is either driving open or driving closed.

Tee in a pressure gauge in the lines to the pressure switch. Start the unit and observe the voltmeter and pressure gauge. When the control is satisfied, the meter reading should fall to zero. Mark down the reading on the pressure gauge as the low actuation point. As the building cools off, the VAV boxes will start to close. This will raise the static pressure to the high actuation point. If this point is too high or too low, adjust the range screw accordingly. Refer to "Differential Pressure Switch" section for additional information.

If low actuation point is too high or too low, adjust the null adjustment screw. Turn the screw counterclockwise to lower the static pressure and widen the null or turn the screw clockwise to raise the static pressure and close the null. Maximum differential is 0.17" to 0.31" W.C., depending on setpoint setting. Do not attempt to set the differential any wider than these maximum values.

### CHECK, TEST & START PROCEDURE

#### CENTRAL CONTROL PANEL

The check of the constant volume and VAV central control panels (optional equipment) simply consists of checking for continuity of certain circuits at TS1 and TS4 terminal blocks with an ohmmeter to verify proper field wiring from the panel to the unit.

With disconnect switch in the OFF position, place leads of ohmmeter as indicated in Table 15. Continuity must exist in all cases; if not, check the wiring and connections.

#### VAV Unit Control Panel — Sequence of Operation

The VAV remote control panel is designed to provide in-the-space programming of unit operation and to make operation of the unit completely automatic. The panel will operate as follows:

**Cooling Only:** If the unit was ordered without an optional heating system, the seven-day timeclock will switch the unit from "occupied" (cooling) to "unoccupied" (no cooling), depending on the setting of the timeclock trippers. The time of changeover should be set to suit the occupancy of the building. All remote panels are furnished with a one-hour morning warm-up control timer which is provided to permit the space temperature to return to normal setting prior to activating cooling cycle. Because of the morning warm-up timer, the outside air damper is shut and the unit will not go into the cooling mode for one hour after the timeclock has switched from the "unoccupied" to the "occupied" mode. If it is desired to change the mode from "unoccupied" to "occupied" on an occasional basis, because of overtime or weekend work, it is suggested that the override timer located on the face of the panel be used for this purpose, rather than resetting the timeclock trippers.

**Heat/Cool Units:** With the timeclock in the "unoccupied" mode, the operation of the unit may be controlled by a field installed night setback thermostat (optional from manufacturer). This thermostat should be located wherever convenient in the occupied space, and should be set to maintain building temperature at the desired night setback level, usually 55°F. The heating system in the unit will cycle on demand of the night setback thermostat.

When the timeclock switches operation from the "unoccupied" mode to the "occupied" mode, the one-hour warm-up timer is activated and control is transferred to the warm-up relay RW and to the two-stage unit mounted return air ther-

mostat TW (factory set at 67°F, field adjustable).

When the unit is in the morning warm-up or night setback mode, the outside air damper is shut. Normally open contacts on relays RW (warm-up mode) or RN (night setback mode) close, energizing terminal 21 and relay R6 within the unit. Relay R6 bypasses the differential pressure switch and causes the discharge damper to open. When the damper is completely open, the auxiliary switch DDA closes, allowing power to flow to the return air thermostat TW. If TW is calling, the first stage heat and blower will be energized by relay R4 and the second stage heat will be energized by relay R5.

Normally open contacts of the warm-up relay RW are terminated on terminals in the VAV control panel designated MW1 and MW2. Similarly, normally open contacts of a field supplied relay RN should be terminated on MW1 and MW2 when night setback is used. If necessary, these contacts may be used to drive open all the zone VAV boxes during the morning warm-up period. (Some means of opening the VAV boxes when the unit heating is energized must be provided.)

When the warm-up timer has completed its one hour period, control of the unit is switched to the day relay RA and the unit will function in the cooling mode with the SSVC controlling the mechanical cooling, or the economizer, if the outdoor temperature conditions are proper. If the unit is equipped with electric heat, SSVC controlled discharge air tempering may also be enabled through the day relay RA. Refer to unit wiring diagram and Diagrams 4 and 12.

Table 15.

FUNCTION	TERMINALS JUMPED*
FAN ON	C TO 1
COOL ON	C TO 2
COOL FAILURE	C1 TO 3
HEAT ON	C TO 4
HEAT FAILURE	C TO 5
CLOGGED FILTER	C TO X

\*Remove factory wiring from unit terminals before checking.  
NOTE: All signal lights are not present on all panels.

Wiring Diagram 12. Remote VAV Panel

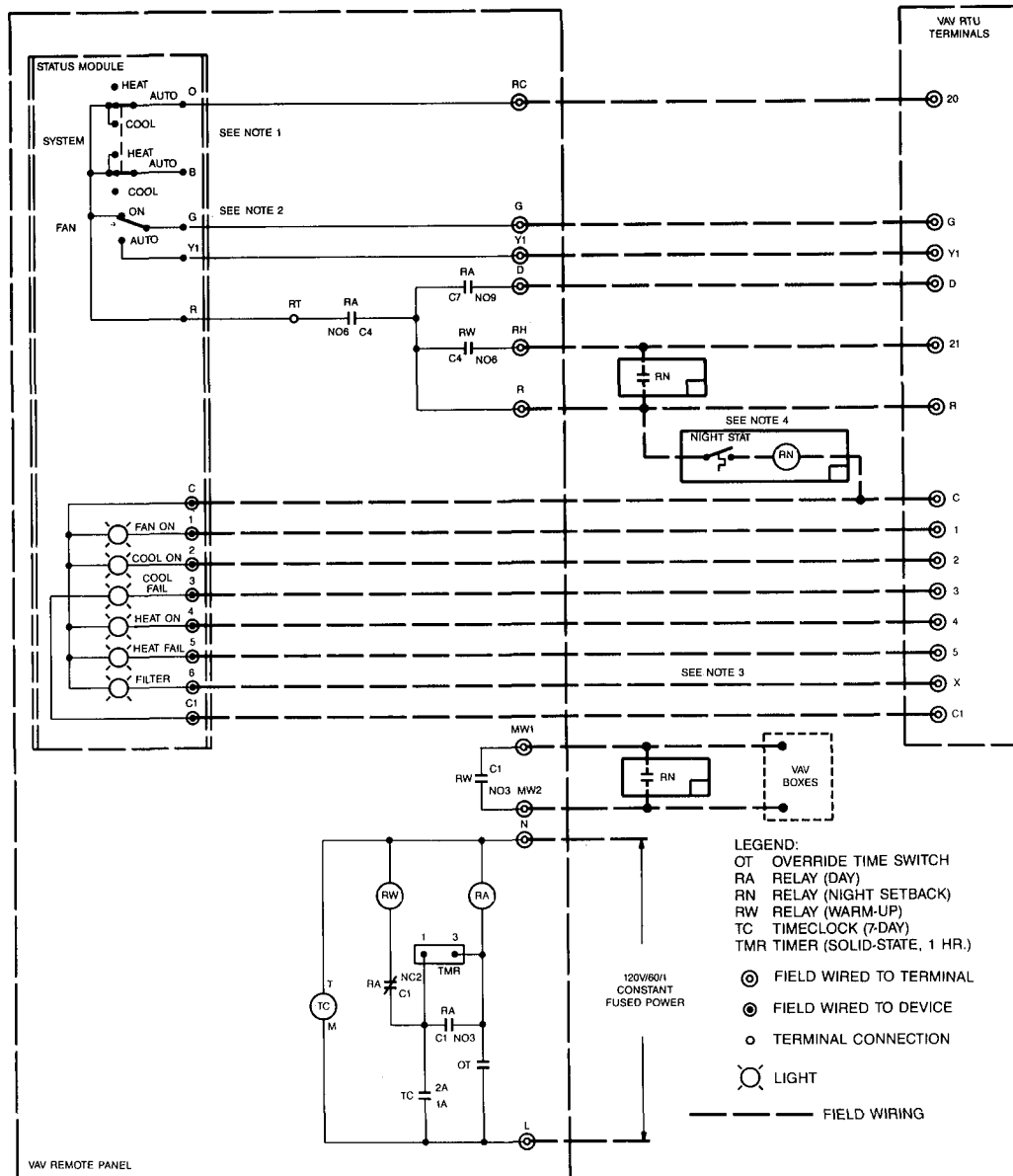

NOTES:

1. For normal operation, system switch should be in "COOL" or "AUTO" position. "HEAT" position is same as "OFF."
2. For normal VAV operation, fan switch should be in "ON" position.
3. Units not equipped with filter flag option eliminate connections between unit "X" and status module "6" terminals.
4. Night setback thermostat and relay RN are field supplied.

**CHECK, TEST & START PROCEDURE  
GAS HEAT**

**Gas Supply Pressures & Regulator Adjustments**

The first step in checking out the gas-fired furnace is to test the gas supply piping to the unit for tightness and purge the system of air using methods outlined in the latest edition of the National Fuel Gas Code (ANSI Z223.1).

Verify that the disconnect switch is in the "OFF" position.

A soapy water solution should be used to check for gas leaks. Since the unit is subject to considerable jarring during shipment, it is extremely important that all gas connections and joints be tested for tightness.

Gas piping downstream from the unit inlet should be checked for leaks during the subsequent sequence check.

The supply gas pressure should be adjusted to 7.0" W.C. on natural gas and 11.0" on propane gas with the gas burners operating. If there is more than one unit on a common gas line, the pressures should be checked with all units under full fire. Pressure taps are provided on both the upstream and downstream sides of the gas valve. The normal manifold pressure for full input is 3.5" W.C. on natural gas and 10.0" for propane gas. Minimum gas supply pressure is 5.5" W.C. for natural gas and 8.0" for propane gas. In order to obtain rating, gas supply must be 11.0" W.C. for propane gas. The pressure regulator on propane gas models is adjusted for 11.0" W.C. manifold pressure and is intended to prevent over-firing only.

Due to the fact that gas appliances located more than 2000 feet above sea level must be de-rated 4% per 1000 feet of total elevation and that variance in gas heating value and specific gravity require change in manifold pressure to obtain rating, it is mandatory that the input be adjusted at the installation site. **All installations should be made as outlined in the latest edition of the National Fuel Gas Code ANSI-Z223.1.** The section entitled "Procedures To Be Followed To Place An Appliance in Operation" should be followed. Refer also to the "User's Information Manual" supplied with the unit for additional information on the gas furnace.

**Table 16. Heat Exchanger Specifications**

MAX. UNIT INPUT BTUH	MAX. INPUT PER FURNACE BTUH	MIN. INPUT BTUH	NO. CELLS PER FURNACE	MAX. STUH PER CELL
500,000	250,000	200,000	10	25,000
400,000	200,000	160,000	8	25,000

**Table 17.**

BURNER ORIFICES		ORIFICE SIZE (DRILL)	
FURNACE	BTUH/CELL	NATURAL GAS	PROPANE
N50	25,000	40	53
N40	25,000	40	53
HIGH ALTITUDE CANADA			
N50/N40	22,500	42	55

**▲ WARNING**

Should overheating occur or the gas supply fail to shut off, turn off the manual gas valve to the appliance before shutting off the electrical supply.

**Sequence of Operation — Gas Heating**

**CAUTION:** Do not fire gas furnace with burner box cover removed. This is extremely hazardous. Sightglasses are provided to monitor flame.

**Constant Volume:** With electricity and gas turned on, the thermostat system switch in the "HEAT" or "AUTO" position, and the fan switch in the "AUTO" position, the thermostat will close the circuit between unit terminals R and W1 (R-W1) when the temperature falls below the thermostat setting. This energizes relay R4 and heat anticipators HA1 and HA2. Relay R4

energizes the ventor motors VM1 and VM2.

**VAV\*:** Gas heat on VAV rooftop units is used for morning warm-up (if a VAV remote panel is used) or night setback heating only. The SSVVC does not control the heating cycle. When the VAV remote panel timeclock initiates the one-hour morning warm-up cycle, it energizes the warm-up relay RW which closes the circuit between unit terminals R and 21 (R-21) and energizes relay R6 in the unit. Normally open contacts on RW are supplied for connection to the VAV boxes so that they open fully on a call for heat. A night setback thermostat, if used, should be wired so that it also energizes terminal 21 and opens the VAV boxes on a call for heat. Normally open contacts on relay R6 act to fully open the discharge damper. (Another set of R6 normally open contacts connected to the SSVVC act to lock out cooling during a call for heat.) When the discharge damper is open, the end switch DDA closes, supplying power to terminal 22 and the unit mounted warm-up thermostat TW. If TW is calling, power will be supplied to terminal W1 so that relay R4 will be energized. A mercury bulb switch mounted on the discharge damper proves that the damper is open; when the mercury switch closes, relay R9 is energized. Normally open contacts of relays R4 and R9 must both be closed for power to flow to the furnace control circuits from transformer TR4. When power is supplied to the furnace, heat anticipators HA1 and HA2 will be energized. Relay R4 energizes the ventor motors VM1 and VM2.

**All Units:** Operation of the ventor motors closes the centrifugal switches VS1 and VS2 located on the ventor motors. If the temperature is low enough to close the limit controls HTL1, HTL2, HTL4, HTL5, HTL6 and HTL7, a "3-try" spark ignition sequence is initiated. Simultaneously, the two Slave Ignition Controls (SIC1 and SIC2) spark for ignition, the indicator LED's flash once (indicates control is functional) and the gas valve redundant and first stage operators (W1-C1) are energized.

When the burners are ignited, a minimum 2 micro-amp DC current should flow through the flame between the sensor and ground electrodes. When the controller proves the flame has been established, it will keep the gas valve energized and discontinue the ignition spark.

If the flame is not sensed by the SIC module within 4 seconds, the gas valve is de-energized, the spark is stopped and the ignition control enters the "re-try" mode. In the re-try mode, the ignition control allows the ventor blower to purge for 60 seconds before starting the ignition spark and energizing the valve. If flame is not sensed within 4 seconds, the valve is de-energized, the spark is discontinued and a second re-try is attempted. If the second re-try is unsuccessful, the ignition control closes the valve and locks itself out (indicated by a continually flashing LED). The control may be reset by momentarily interrupting power. This can be accomplished by briefly lowering the thermostat setpoint below room temperature, by turning the system switch to OFF or by shutting off the main power to the unit.

**Note:** If indicator LED is on continuously, it is likely that the ignition control has an internal defect. To make sure, interrupt thermostat power for a brief period and then restore. If LED stays on as before, replace the control. If indicator LED flashes, it is likely that something is wrong external to the ignition control.

Natural gas models are equipped with two-stage gas valves. Propane gas models are single-stage valves only. On natural gas models, manifold pressure will be approximately 0.9"W.C. on low fire and 3.5" on high fire. On propane gas models, manifold pressure will be approximately 10" W.C. (assuming 11" W.C. gas supply pressure to the gas valve).

The combined heat from the heat anticipators (HA1 and HA2) and the burning gas cause the fan controls FS1 and FS2 to close their contacts (factory set at 140°F, field adjustable), energizing purge relay PR which in turn energizes contactor C5 and starts the evaporator motor EM. Operation

\*Item not submitted to ETL or CGA.



of the evaporator blower causes air to circulate past the heat exchanger and delivers heated air to the conditioned space.

**Constant Volume:** On natural gas models, in the event that the temperature at the thermostat continues to fall, the thermostat will also close the circuit between unit terminals R and W2. This will energize the second stage on both gas valves (W2-C2) and the gas manifold pressure will increase to approximately 3.5" W.C. The air supplied to the heated space will increase in temperature.

When the space temperature rises, two-stage thermostats will first open R-W2 and finally R-W1. Single-stage thermostats will open R-W1.

**VAV Units:** On natural gas models, in the event that the temperature at the warm-up thermostat continues to fall, the thermostat will also close the circuit between unit terminals 22 and W2. This will energize relay R5 and close its normally open contacts in series with the second stage of each gas valve (W2-C2). The gas manifold pressure will increase to approximately 3.5" W.C. The air supplied to the heated space will increase in temperature.

When the return air temperature rises, the warm-up thermostat will first open 22-W2 and finally 22-W1.

On night setback operation, the setpoint of the setback thermostat is probably lower than the setpoint of the warm-up thermostat. In this case, the setback thermostat will open R-21 when the space temperature rises. This simultaneously de-energizes both terminals W1 and W2.

**All Units:** De-energizing terminal W1 will cause the gas valve to close. As the heat exchanger cools, the temperature will decrease at the fan controls (FS1 and FS2) and when the temperature reaches the setpoint (factory set at 100°F, field adjustable), the fan controls will open their contacts causing the evaporator blower to stop.

When the building is at normal operating temperature, the fan controls should be set so that they shut off at a temperature only a few degrees above normal return air temperature. This will result in the minimum loss of heat to the outdoors.

The furnace has three types of high temperature limit controls which can shut down the burners. They do not shut down the ventor motors.

The limit controls HTL1 and HTL5, adjacent to the blower inlet, are set to open at 110°F and close at 100°F. In the event that the temperature at one of the limit controls exceeds 110°F after blower shutoff, the limit contacts may be open at the time of a call for heating. If this occurs, the gas will not turn on. The heat anticipators are energized and will cause the fan controls to turn on, resulting in operation of the evaporator blower. This will cause the limit control(s) to reset and operation will return to normal.

The limit controls HTL2 and HTL4, within the heat exchanger, are set to open at 170°F on 500 MBH furnaces and 160°F on 400 MBH furnaces. If the temperature at HTL2 or HTL4 exceeds the setpoint, the burner will shut down and the blower will continue to operate.

The flame roll-out limit controls HTL6 and HTL7, mounted on the burner compartment covers, are set to open at 225°F. They have a manual pushbutton reset that cannot be actuated until the limit control has cooled.

### Input Rating

It is the responsibility of the contractor to adjust the gas input to the unit. The input rate can be calculated by using the formula:

$$\text{Input Btu/Hr.} = \frac{3600 \times HV}{T}$$

HV=Heating value of fuel=Btu/Ft<sup>3</sup> of gas

T=Time in seconds per Ft<sup>3</sup> of gas flow as read from gas meter

Adjust input rate by varying the adjustment of the gas pressure regulator. All adjustments must be made with furnace operating at high fire and at normal operating temperature. The furnace should be adjusted to obtain a temperature

rise within the range specified on the unit dataplate. Refer to Table 18.

**CAUTION:** Do not exceed input rating or manifold pressure values on the unit dataplate. If the input rate on the unit dataplate cannot be attained without exceeding the manifold pressure listed on dataplate, contact a qualified service agency.

**Natural Gas:** Natural gas valves have non-adjustable pressure regulators. An external type, positive shutoff service pressure regulator may be required.

**Propane Gas:** Propane gas valves are equipped with adjustable pressure regulators. Clockwise rotation of the pressure regulator dial increases pressure and gas flow rate. Turn dial counterclockwise to decrease pressure and gas flow rate.

**Note:** Thermal efficiency of the furnace is a product efficiency rating determined under continuous operating conditions independent of any installed system.

### Burner Flame Requirements

Burner flame should run the length of the ribbons and be 3" to 4" in height. The flame should be blue in color with a slightly yellow tip. If for any reason the flame should lift from the burner, change color to orange, or start rolling out from under the flash shield after ignition, an adjustment is necessary or the heat exchanger needs to be inspected and cleaned. Refer to Figure 28.

Figure 28. Burner Flame

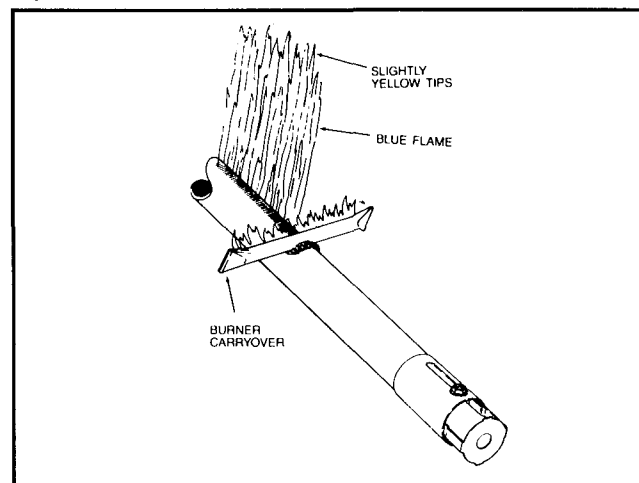

### Ignition Electrode & Flame Sensor

The ignition electrode and flame sensor assembly is not field adjustable. There should be a gap spacing of 0.125" ± 0.032" between the ignition and ground electrodes. Any alterations to this assembly may create a hazardous condition that could cause property damage, personal injury or death.

**CAUTION:** Do not apply power to the ignition control module unless the ignition electrode assembly is properly connected and grounded or damage to the control module may result.

### Primary Air Adjustment

These units have individual primary shutters on each burner. Air shutters must be adjusted to obtain proper air-gas mixture. To gain access to the burners, remove heating access panel and burner box cover. To adjust air shutters, operate unit for at least 15 minutes. Loosen the lock screw and open or close the air shutter. (Each time an adjustment is made, the lock screw must be tightened and the burner box cover must be replaced to observe the burner flame.) If the flame is yellow tipped, open the air shutters to admit more primary air. Open the shutters until the yellow tips just disappear. After adjustment, recheck the unit from a cold start. Secure shutters in final position by tightening the fastening screw. Refer to Figure 29.



**CAUTION:**

Use care in removing burner box cover to avoid damage to gasket material.

**WARNING**

Burner box cover and gasket must be completely reinstalled. DO NOT omit any original cover screws.

Figure 29. Air Shutter

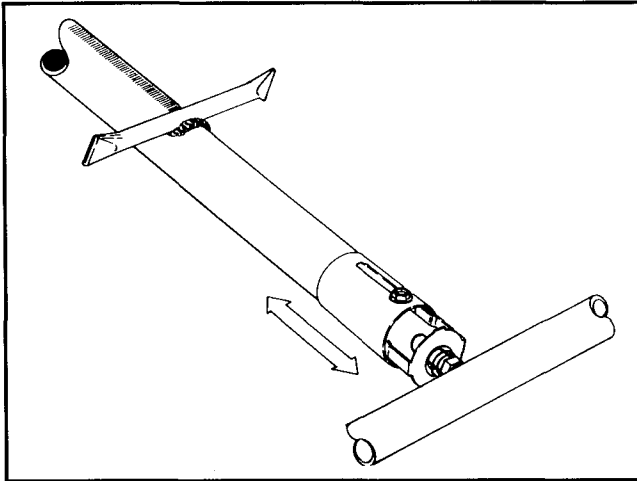

Table 18.

UNIT MODEL	GAS FURNACE INPUT RATING BTU/HR	AIRFLOW NOMINAL FT <sup>3</sup> /MIN	NOMINAL TEMP RISE °F	TEMP RISE RANGE °F
CUR251	500,000	10,000	37.2	20 — 50
		12,000	31.0	20 — 50
		14,500	25.6	20 — 50
CUR300 CUR351	400,000	10,000	30.3	15 — 45
		12,000	25.2	15 — 45
		14,500	20.9	15 — 45

**CHECK, TEST & START PROCEDURE  
ELECTRIC HEAT**

**Wiring Tightness Check**

With disconnect switch in the OFF position, check all electric heater connections for tightness. Since the unit is subjected to considerable jarring during shipment, it is extremely important that this check is thorough.

**Sequence Check — Constant Volume**

Set the thermostat in the conditioned space at a point at least 10°F above zone temperature.

Remove the thermostat wire from terminal W2 at TS1 terminal block and close disconnect switch. The following operational sequence should be observed.

1. First stage heat relay R4 makes and closes contacts 4-6 to energize evaporator motor contactor C5.
2. Contacts 1-3 close to activate heater contactors C6 and C9. While electric heater is operating at first stage, attach thermostat wire to terminal W2 at TS1 terminal block.
3. Second stage heat relay R5 makes and closes contacts 2-4 to activate heater contactors C7, C8 and C10.

**NOTE:** The number of heater contactors used depends on heating capacity and voltage.

Observe contactors for several cycles. Contactors should cycle first and second stage according to thermostat demand. Open disconnect switch.

Set thermostat temperature levers and subbase switches to desired positions.

**Sequence Check — VAV**

Set SSVC setpoint and changeover thermostat to a point at least 10°F above the return air temperature.

Remove wire 293 from terminal W2 at TS1 terminal block and close disconnect switch. The following operational sequence should be observed. Note that the SSVC initiates a two-minute time delay after any switching action.

1. First stage heat relay R4 makes and closes contacts 4-6 to energize evaporator motor contactor C5.
2. Contacts 1-3 close to activate heater contactors C6 and C9. While electric heater is operating at first stage, attach wire 293 to terminal W2 at TS1 terminal block.
3. Second stage heat relay R5 makes and closes contacts 2-4 to activate heater contactors C7 and C8.

**NOTE:** The number of heater contactors used depends on heating capacity and voltage.

Observe contactors for several cycles. Contactors should cycle first and second stage heat according to SSVC demand.

Open disconnect switch.

Set SSVC setpoint and changeover thermostat to desired positions.

**CHECK, TEST & START PROCEDURE  
THERMOSTAT, NIGHT SETBACK & TIMECLOCK**

**Thermostat Final Check — Constant Volume**

With the thermostat fan switch at AUTO, operate the unit through at least one complete cycle with the thermostat system switch at COOL and one cycle with the system switch at HEAT.

Place the fan switch at ON. The fan should run continuously.

Proper control of the indoor air temperature can only be achieved if the thermostat is calibrated to the heating and/or cooling system. A vital consideration of this calibration is related to the thermostat heat anticipator.

Anticipators for the cooling operation are generally preset by the thermostat manufacturer and require no adjustment. Anticipators for the heating operation are of two types: preset or adjustable. Those that are preset will not have an adjustable scale and are generally marked accordingly.

Thermostat models having a scale as shown in Figure 30 must be adjusted to each application.

Figure 30. Typical Heat Anticipator

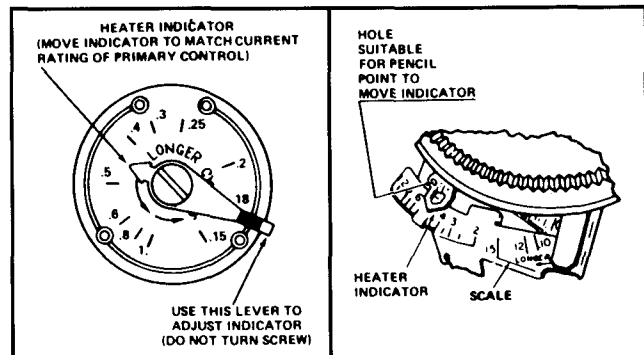

In most cases this adjustment setting can be found in the thermostat instructions. If this information is not available or if the correct setting is questioned, the procedure below should be followed:

1. Wrap 10 loops of single strand, insulated thermostat wire around the prongs of an ammeter. Set the scale to the 1 to 5 or 1 to 6 amp scale.

2. Connect the uninsulated ends of the wire jumper across terminals R and W1 on the subbase. See Figure 31. This test must be performed without the thermostat attached to the subbase.
3. Let the heating system operate in this position for about one minute. Read the ammeter scale. Whatever reading is indicated must be divided by 10 (for 10 loops of wire). This is the setting at which the adjustable heat anticipator should be set.

$$\text{Formula: } \frac{\text{Ammeter Reading}}{10 \text{ Loops}} = \text{Anticipator Setting}$$

4. If a slightly longer cycle is desired, the pointer should be moved to a higher setting. Slightly shorter cycles can be achieved by moving to a lower setting.
5. On units with two stages of heat, check second stage heat anticipator setting by placing a jumper across terminals R and W1; repeat steps 1 through 3 taking amp reading of R to W2 jumper.
6. Remove the jumper wire(s) and reconnect the thermostat. Check the thermostat in the heating mode for proper operation.

**Note:** The length of the heating cycle can also be affected by the fan limit control settings. The fan "ON" and "OFF" settings should be checked at this point.

Move the thermostat temperature levers and subbase switches to desired positions.

Figure 31.

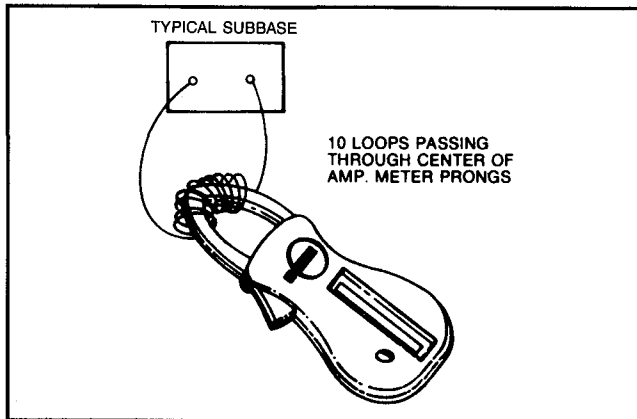

### Night Setback Thermostat Check (Optional Equipment) — Constant Volume

The night setback thermostat controls the unit by jumping the timeclock and completing the circuit through the main thermostat. The unit heating will cycle off the night thermostat setpoint since it is lower than the main thermostat setpoint.

With timeclock contacts open, set night setback thermostat and space thermostat 10°F above zone temperature. Unit should operate on heating cycle.

Restore night thermostat to normal setting (recommend 55°F). Reset space thermostat to desired position.

### Night Setback Thermostat Check (Optional Equipment) — VAV

The night setback thermostat controls the unit by completing the circuit from unit terminal R to 21. This effectively bypasses the SSVC control and the unit heating then cycles off the night thermostat setpoint. Before the heat is activated, the discharge damper is driven to the fully open position through relay R6.

**CAUTION:** When a night setback thermostat is used, some means of opening VAV boxes on a call for heat must be provided.

With timeclock or manual system switch contacts open, set night thermostat 10°F above zone temperature. Unit should operate on heating cycle.

Restore night thermostat to normal setting (recommend 55°F).

### Timeclock Check (Optional Equipment)

Manually open and close timeclock contacts to check if it operates unit. Set time dial to correct time. Adjust cut-in and cut-out points.

## NORMAL OPERATING CONDITIONS

Once the Check, Test & Start of the unit has been completed, it is necessary to return the unit to normal operating conditions:

- Close all compartments
- Install all external panels
- Remove any jumpers or test equipment
- Restore electrical power to unit

## AIR BALANCING

The drives on the supply and exhaust fans are typically set in the middle of the rpm range. The drive motor sheave pitch diameter is field adjustable for the required airflow. Refer to "Drive Adjustments" section below. Refer also to "Power Exhaust" check, test and start procedure for additional information.

When the final adjustments are complete, the current draw of the motors should be checked and compared to the full load current rating of the motors. The amperage must not exceed the service factor stamped on the motor nameplate.

The total airflow must not be less than that required for operation of the electric heaters or the furnaces.

The operating balance should be checked with the economizer at full outside air and at minimum outside air.

Upon completion of the air balance, it is a common industry recommendation that the variable pitched motor sheave be replaced with a properly sized fixed sheave. A matching fixed sheave will provide longer belt and bearing life and vibration free operation. Initially, it is best to have a variable pitched motor sheave for the purpose of air balancing, but once the balance has been achieved, fixed sheaves maintain alignment and minimize vibration more effectively.

### BUILDING PRESSURIZATION BALANCE — VAV

A building system design will generally have assumed that the VAV terminal boxes will not all be calling for maximum airflow at the same time. Before attempting to balance the unit airflows, determine what the actual design maximum airflow is. In the absence of such information, a reasonable maximum airflow condition can be achieved by closing 20% of the VAV box capacity. The terminal box maximum flow rates must be known in order to determine which boxes to close. The boxes are closed by positioning the corresponding wall thermostats to their highest setting.

### Supply Fan Adjustment

1. Set terminal boxes for maximum airflow as described above.
2. Energize the fans; observe that both the discharge and tracking damper actuators begin to operate and allow the system to stabilize at the floating pressure switch setpoint.
3. If the discharge damper actuator drives fully open and there is still insufficient system pressure to satisfy the switch setpoint, the supply fan rpm must be increased. Likewise, if the system stabilizes with the discharge damper actuator less than 75% open, there is excessive airflow and the supply rpm must be reduced.

**Caution:** Open main power disconnects before attempting any fan speed adjustments. Severe injury to personnel could result from starting fan while adjusting fan speed.

4. Set all terminal boxes for normal operation.

### DRIVE ADJUSTMENTS — MOUNTING & ADJUSTING MOTOR SHEAVES "VM" & "VP" Variable Pitch Key Type Sheaves (See Figure 32.)

#### MOUNTING:

1. All sheaves should be mounted on the motor or driving shaft with the setscrew "A" toward the motor.
2. Be sure both driving and driven sheaves are in alignment and that shafts are parallel.
3. Fit internal key "D" between sheave and shaft, and lock setscrew "A" securely in place.

#### ADJUSTING:

1. Loosen setscrews "B" and "C" in moving parts of sheave and pull out external key "E". (This key projects a small amount to provide a grip for removing.)
2. Adjust sheave pitch diameter for desired speed by opening moving parts by half or full turns from closed position. **DO NOT OPEN MORE THAN FIVE FULL TURNS FOR "A" BELTS OR SIX FULL TURNS FOR "B" BELTS.**
3. Replace external key "E" and securely tighten setscrews "B" over key and setscrews "C" into keyway in fixed half of the sheave.
4. Put on belts and adjust belt tension. **DO NOT FORCE BELTS OVER GROOVES.**
5. Future adjustments should be made by loosening the belt tension and increasing or decreasing the pitch diameter of the sheave by half or full turns as required. Readjust belt tension before starting drive.
6. Two-groove sheaves must have both halves adjusted by the same number of turns from closed position to insure the same pitch diameter.
7. Be sure that all keys are in place and that all setscrews are tight before starting drive. Check setscrews and belt tension after 24 hours service.

Figure 32.

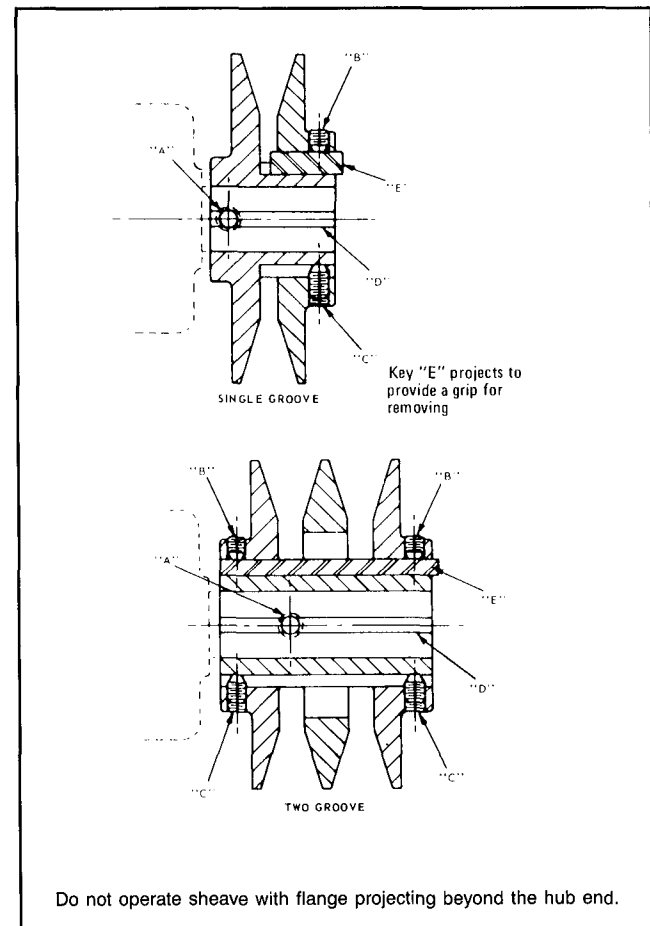

## MAINTENANCE

Installation and maintenance are to be performed only by qualified personnel who are familiar with local codes and regulations and experienced with this type of equipment. **CAUTION:** Sharp edges and coil surfaces are a potential injury hazard. Avoid them.

**⚠ WARNING**

**MOVING MACHINERY HAZARD  
DISCONNECT POWER TO THIS UNIT AND PADLOCK  
AT "OFF" BEFORE SERVICING THE FANS.**

Preventative maintenance is the best way to avoid unnecessary expense and inconvenience. Have this system inspected at regular intervals by qualified service personnel, at least twice a year. Routine maintenance should cover the following items:

1. Tighten all belts, setscrews, and wire connections.
2. Clean evaporator and condenser coils mechanically or with cold water, if necessary. Usually any fouling is only matted on the entering air face of the coil and can be removed by brushing.
3. Lubricate motor and fan shaft bearings (see below).
4. Align or replace belts as needed.
5. Clean or replace filters as needed (see below).
6. Check compressor oil level and check for refrigerant leak if sightglass is low. Add refrigerant oil only after determining how the original oil was lost.
7. Check refrigerant sightglass. Check for refrigerant leak if sightglass is flashing with steady-state operation of unit.
8. Check for blockage of condensate drain.
9. Check power and control voltages.
10. Check running amperage.
11. Check operating temperatures and pressures.
12. Check and adjust temperature and pressure controls.
13. Check and adjust damper linkages.
14. Check operation of all safety controls.
15. Examine gas furnaces (see below and the User's Information Manual).
16. Check condenser fans and tighten setscrews.

### FILTERS

Every application may require a different frequency of replacement or cleaning of dirty filters. Disposable filters must be replaced and permanent (wire mesh) filters must be cleaned at least every three (3) months during operating seasons.

Filters supplied with the units are the disposable type and are as follows:

UNIT SIZE	QUANTITY	FILTER SIZE	PART NUMBER
25, 30, 35 TON UNITS	10	20×25×2	000160A-00

To remove the filters, remove the filter access panel on the right side of the unit. The panel is held in place by captive quarter-turn screws. See Figure 33.

Filters are five deep in the two filter racks and an angle plate with a string-pull is supplied for each filter rack to remove all of the filters. Pull on the end of the string and the filters will slide out. When replacing filters, make certain that the angle plate is inserted before the first replacement filter is inserted.

### LUBRICATION

The ventor motor (gas fired furnace) and the condenser fan motors are permanently lubricated. For lubrication of the compressors, Copeland recommends using Suniso 3GS, Texaco WF32, or Calumet R015 oils. All three oils are compatible if mixed, and are suitable for both high and low temperature systems.

Figure 33.

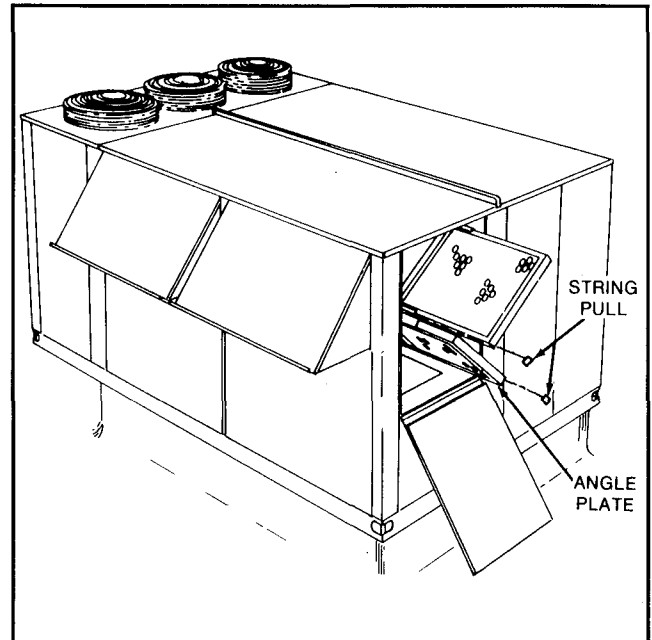

**Motor Bearings** — Evaporator motor should have grease added after every 2,000 hours of operation. Relubricate while motor is warm and at a standstill. Remove and clean upper and lower grease plugs. Insert grease fitting into upper hole adding a small amount of clean grease with a low pressure gun. Run motor for ten minutes before replacing plugs.

**Caution:** Excessive grease will overheat the bearings. Use only a high grade mineral grease with a 200°F safe operating temperature.

**Note:** Specific greasing instructions may be found on a tag attached to the motor. If special lubrication instructions are shown on the motor nameplate, they will supersede all other instructions.

**Fan Shaft Bearings** — The bearings are prelubricated and do not require addition of grease at time of installation. Lubrication intervals vary with the period of operation and the air temperature around the bearings. Follow the instructions below.

TEMPERATURE RANGE	CONTINUOUS OPERATION	12-HOUR DAY OPERATION
60°F to 80°F	2 Years	4 Years
81°F to 100°F	1½ Years	3 Years

For conditions other than those listed, refer to lubrication label located near lubrication fitting. The following NGLI No. 2 greases are recommended for use on fan shaft bearings:

- Mobil Oil Co. Mobilux 2
- Texas Oil Co. Regal AFB 2
- Shell Oil Co. Alvania 2
- Standard Oil Co. (CA) Chevron SRI 2
- American Oil Co. Rykon 2

Turn fan wheels while greasing. Where possible observe seals and add grease only until a slight bleeding is noted. **DO NOT OVERLUBRICATE.**

## GAS FIRED FURNACE INSPECTION AND CLEANING

Inspect the vent system for evidence of corrosion or corrosion particles. Refer to Figure 34.

All flue product carrying areas of the furnace, its vent system, and main burners should be examined by a qualified service agency before the start of each heating season. This examination is necessary for continued safe operation. Particular attention should be given to deterioration from corrosion or other sources. The examination is accomplished in the following manner:

1. Disconnect power to the unit.
2. Remove the fan-limit control and the ventor blower so that the front partition can be removed.
3. Remove the screws holding the front partition and pull the panel forward to remove it. Use care to avoid damage to the insulation.
4. The flue box can now be removed taking care to avoid destruction of the gasket since it must be reused when the furnace is reassembled. Similar care must be exercised during the removal of any subsequent gaskets.
5. Remove the restrictor plate and its gasket and then remove the flue baffles in the top of each heat exchanger cell.
6. Now remove the burner box cover at the bottom of the furnace, its gasket and the flash shield.
7. Remove the burners from the unit. Label each one so that they can be reinstalled in the same location as they

were originally installed. This especially applies to the burner with the ignition electrode and sensor attached.

8. After the burners have been removed from the unit, tap the end of each one lightly on the ground thereby removing any residue from inside the burner. Run a vacuum over the burner slots to remove any foreign materials.
9. Using a flashlight and mirror, inspect each vertical flue passage for soot. Any accumulation of soot can be removed using a flexible wire brush inserted in the lower openings. At completion, remove any residue that may have dropped to the base of the cells or furnace.
10. If any evidence of deterioration of the heat exchanger or flue passages is evident, contact a qualified service agency.
11. Upon completion of the inspection and clean-up, install all parts in reverse order from which they were removed.
  - a. All gaskets should be in good condition prior to reassembly.
  - b. Use all screws that were removed. DO NOT reassemble by omitting any screws. All screws are necessary for the integrity and proper performance of the furnace.
12. Inspect and periodically clean the vent outlet (bird screen).

**NOTE:** Periodic observation of the flame through the inspection ports will aid in the determination of whether the burners or cells require cleaning.

Figure 34. Forced Draft Gas Fired Furnace

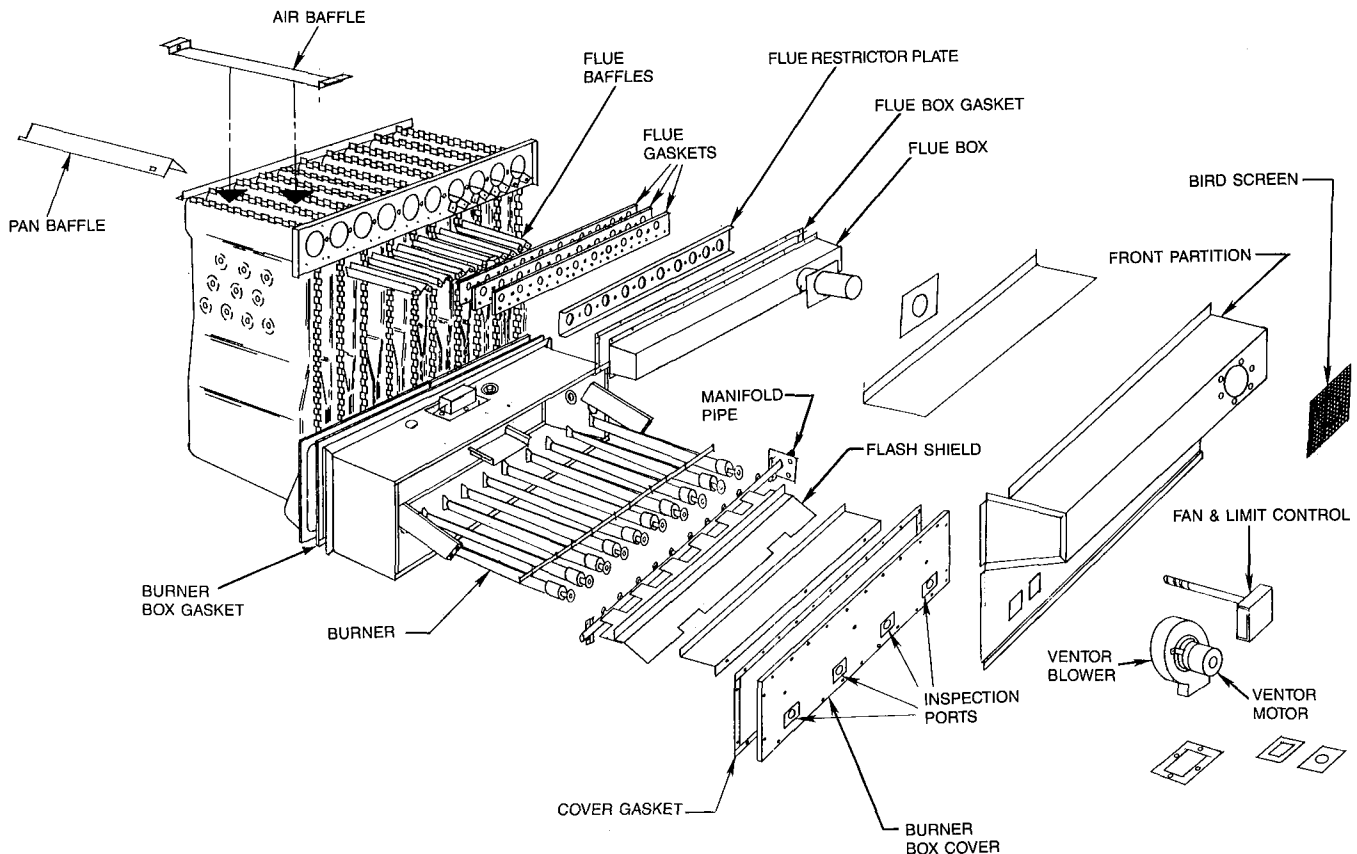

## CUR251, CUR300, CUR351 CONTROLS, SETTINGS & FUNCTIONS

DESCRIPTION	FUNCTION	SYMBOL	SETTING	RESET	LOCATION	DIFFERENTIAL
CONDENSER PRESSURE SWITCH	Maintains condenser pressure by cycling the condenser fans in response to condenser pressure.	CPS1 (violet wire) CPS2 (yellow wire) CPS3 (brown wire)	Closes at 225 psig Opens at 150 psig Closes at 250 psig Opens at 170 psig Closes at 280 psig Opens at 190 psig	Auto	Condenser Section on liquid line	75 psig 80 psig 90 psig
COMPRESSOR LOCKOUT TIME DELAY	Prevents short cycling of compressor.	GDM	5 Minutes	Auto	Main Control Panel	N/A
HIGH PRESSURE CONTROL	Stops compressor when discharge pressure is too high.	HP	Opens at 425 ± 20 psig Closes at 310 ± 10 psig	Auto	Condenser Section on discharge line	115 psig, fixed
LOW PRESSURE CONTROL	Stops compressor when suction pressure is too low. Safety device and used for optional pumpdown.	LP	Opens at 10 ± 4 psig Closes at 40 ± 10 psig	Auto	Condenser Section on suction line	30 psig, fixed
OIL PRESSURE CONTROL	Stops compressor if oil pressure drops below setpoint for 120 seconds.	OP	Pressure sensor opens above 14 psig oil pressure. If pressure drops below 9 psig, the sensor closes, energizing a 120 second delay before stopping the compressor.	Manual	On Compressor	5 psig, fixed
SOLID-STATE COMPRESSOR MOTOR PROTECTOR (TEXAS INSTRUMENTS)	Protects motor from high temperature by sensing winding temperature.	SM	500 ohms cold to 20,000 ohms hot	Auto from 2700—4500 ohms	Compressor Junction Box	15,000 ohms
COMPRESSOR UNLOADER	Solenoid valve on compressor head to load or unload compressor (energize to unload; de-energize to load).	US1, 2	N/A	N/A	On Compressor	N/A
COIL LIQUID LINE SOLENOID VALVE	Feeds refrigerant to 2nd half of evaporator when energized.	CLSV	N/A	N/A	Condenser Section	N/A
LIQUID LINE SOLENOID VALVE	Closes off liquid line when de-energized. Prevents refrigerant migration & used for optional pumpdown.	LSV	N/A	N/A	Condenser Section	N/A
HOT GAS BYPASS SOLENOID VALVE	Closes off hot gas bypass line when de-energized. Opens for hot gas bypass during 1st cooling stage (all units) & 2nd cooling stage (CUR300 & CUR351 only).	HGBV	N/A	N/A	Condenser Section	N/A
SOLID-STATE DISCHARGE AIR CONTROLLER (HONEYWELL W7100)	Measures discharge air temperature to control heating-cooling and economizer staging.	SSC (SSVC)	Setpoint: 55°F Reset: 10°F (cool) Control Band: 10°F Adjustable	Auto	Main Control Box	See Honeywell form 60-2507-2
DISCHARGE AIR SENSOR	Senses discharge air temperature, sends signal to SSC.	DAS	N/A	N/A	Below Main Control Box	N/A
CHANGEOVER THERMOSTAT	Sets discharge air controller in either heat or cool mode.	THC	Adjustable 15 to 90°F Recommended 68°F setpoint	Auto	Economizer Section on filter mounting plate (bulb senses return air)	3.5 to 16°F, adjustable (subtractive)
OUTDOOR RESET SENSOR	Senses outside temperature, sends signal to SSC.	ODR	N/A	N/A	Fresh Air Inlet	N/A
WARM-UP THERMOSTAT	Cycles 2 heating stages during morning warm-up.	TW	Adjustable 0 to 100°F Recommended 68°F setpoint	Auto	Economizer Section on filter mounting plate (bulb senses return air)	3°F fixed per switch; 3 to 10°F interstage between switches, adjustable
DIFFERENTIAL PRESSURE SWITCH	Senses and controls duct static pressure.	DPS	1.1" to 3.5" W.C. adjustable	N/A	Main Control Box	0.06" to 0.17" W.C. at minimum setpoint; 0.11" to 0.31" W.C. at maximum setpoint
DISCHARGE DAMPER AUXILIARY SWITCH	End switch makes when discharge damper opens fully to enable night setback or morning warm-up heat circuit.	DDA	N/A	Auto	Inside Discharge Damper Actuator	N/A

Continued on next page

## CUR251, CUR300, CUR351 CONTROLS, SETTINGS & FUNCTIONS (Cont'd.)

DESCRIPTION	FUNCTION	SYMBOL	SETTING	RESET	LOCATION	DIFFERENTIAL
THERMOSTAT ENTHALPY CONTROL	Senses ambient temperature and humidity conditions. Constant Volume Units: It enables either economizer or compressor. VAV Units: It enables economizer only. Compressor is independently controlled.	TE	"B" or as required	N/A	Downstream side of Fresh Air Damper	Temp. — 3.5°F Humidity — 5% Fixed
MINIMUM POSITION POTENTIOMETER	Maintains a minimum opening in economizer damper to provide for ventilation requirements when outside air is unsuitable for cooling.	MPP	As required	N/A	Economizer Section Constant Volume Units: On top of actuator. VAV Units: Inside cover of Honeywell actuator.	N/A
MERCURY BULB SWITCH	Turns on power exhaust fan when economizer damper opens to setpoint.	MB	To attain desired space pressure, as required.	Auto	On Return Air Damper Linkage	N/A
FILTER FLAG	Indicates filters are clogged. Senses pressure drop across filters.	FIL	0.1" to 0.7" W.C., adjustable	Manual	Economizer—Filter Section	N/A
FREEZESTAT	Protects the evaporator from water freeze-up.	FZ	Opens at 32°F Closes at 56°F	Auto	Downstream side of Evaporator Coil	24°F, fixed
FIRESTAT	Cuts power to control circuitry on temperature rise.	HT3-2	Opens at 135°F	Manual	Economizer Section, next to filter flag	25°F to reset
POWER SAVER THERMOSTAT (ELECTRIC HEAT)	Locks out 2 heating stages until outdoor temperature is below setpoint.	PST	Adjustable 0 to 100°F Set as required	Auto	Economizer Section (bulb senses outdoor air)	3°F fixed per switch; 17°F interstage between switches
AIR PRESSURE SWITCH (ELECTRIC HEAT ONLY)	Proves airflow through heaters by sensing pressure difference across evaporator coil.	APS	Closes at 0.03" W.C. Opens at 0.01" W.C.	Auto	Next to evaporator coil on downstream side.	0.02" W.C., fixed
HIGH TEMPERATURE LIMIT SWITCH (ELECTRIC HEAT ONLY)	Cuts power to electric heat elements on temperature rise.	HT1,2	Opens at 200°F	Does not reset, must be replaced	Electric Heat Access Panel, below main control panel	N/A
HIGH TEMPERATURE LIMIT SWITCH (ELECTRIC HEAT ONLY)	Cuts power to heater control circuit on temperature rise.	HT3,4,5,6,7	Opens at 150°F Closes at 110°F	Auto	Electric heat access panel, below main control box	40°F, fixed
HIGH TEMPERATURE LIMIT SWITCH (ELECTRIC HEAT ONLY)	Cuts power to heater control circuit on temperature rise.	HT2A (Electric) HTL1,5 (Gas)	Opens at 110°F Closes at 100°F	Auto	Above Heater, next to blower inlet	10°F, fixed
EVAPORATOR BLOWER OVERLOAD RELAY	Heater coils on each phase of motor heat to break thermal switch if current is too high.	EOL	N/A	Manual	Main Control Panel	N/A
GAS VALVE	Controls opening of stage 1 and stage 2 gas valves.	GV1,2	N/A	N/A	Furnace Section	N/A
VENTOR CENTRIFUGAL SWITCH	Disables gas heat control circuit if ventor motor will not run.	VS1,2	N/A	Auto	Inside Ventor Blower housing	N/A
IGNITOR ELECTRODE & FLAME SENSOR	Ignites main gas and senses flame to prove ignition.	SPK, FP	N/A	N/A	Furnace Section	N/A
IGNITION CONTROL	Creates spark for ignition of main gas.	MIC, SIC	N/A	N/A	Furnace Section	N/A
FAN & HIGH LIMIT CONTROL (GAS HEAT ONLY)	Closes to energize fan when heat exchanger is warm. Heat anticipator — heating element to speed closing of FS. Opens heat control circuit on temperature rise.	FS1,2 HA1,2 HTL2,4	Closes at 140°F Opens at 100°F, adjustable N/A Opens at 170°F (500 MBH) Opens at 160°F (400 MBH) Adjustable	Auto	Furnace Section	40°F, adjustable
FLAME ROLL-OUT LIMIT SWITCH (GAS HEAT ONLY)	Senses burner flame roll-out in burner compartment. Cuts power to heater control circuit on temperature rise.	HTL6,7	Opens at 225°F	Manual	Furnace Section	25°F, fixed 25°F to reset

## PARTS LIST ①

QUANTITY PER UNIT			DESCRIPTION	PART NUMBER
CUR251	CUR300	CUR351		
1			COMPRESSOR, 208-230/460V	713383C-01
	1		COMPRESSOR, 208-230/460V	712193B-01
		1	COMPRESSOR, 208-230/460V	713371C-01
1			COMPRESSOR, 575V	713799C-01
	1		COMPRESSOR, 575V	712803B-01
		1	COMPRESSOR, 575V	713800C-01
1	1	1	CRANKCASE HEATER, 100W	712043B-01
1	1	1	LOW PRESSURE SWITCH	713016C-05
1	1	1	HIGH PRESSURE SWITCH	713016C-09
1	1	1	OIL PRESSURE SWITCH	712007B-01
1	1	1	FREEZESTAT	713018C-01
1			FILTER-DRIER	259389A-00
	1	1	FILTER-DRIER	711033A-01
1	1	1	SIGHTGLASS	712716B-01
<b>CONDENSER SECTION</b>				
3	3	3	CONDENSER FAN BLADE	712058B-01
3	3	3	CONDENSER FAN MOTOR, 1½ HP, 208-230/460V	713012C-01
3	3	3	CONDENSER FAN MOTOR, 1½ HP, 575V	713805C-12
<b>CONDENSER PRESSURE SWITCH</b>				
			<b>CUT-OUT</b>	<b>CUT-IN</b>
1	1	1	150 PSIG	225 PSIG
1	1	1	170 PSIG	250 PSIG
1	1	1	190 PSIG	280 PSIG
<b>EVAPORATOR SECTION</b>				
2	2		BLOWER WHEEL (7½ & 10 HP MOTOR)	713040C-01
2	2	2	BLOWER WHEEL (15 & 20 HP MOTOR)	713041C-01
1	1	1	BLOWER SHAFT	711416B-01
2	2	2	BLOWER SHAFT BEARING	206486B-01
1			MOTOR, 7½ HP, 208-230/460V	713009C-01
1			MOTOR, 7½ HP, 575V	712887C-00
1			MOTOR PULLEY	280459A-00
1			BLOWER PULLEY	009881X-00
1			BELT (MATCHED PAIR)	701874A-06
1			BUSHING	008041X-00
1	1		MOTOR, 10 HP, 208-230/460V	713011C-01
1	1		MOTOR, 10 HP, 575V	713808C-00
1	1		MOTOR PULLEY	007286A-00
1	1		BLOWER PULLEY	008047X-00
1	1		BELT (MATCHED PAIR)	701874A-06
1	1		BUSHING	008041X-00
1	1	1	MOTOR, 15 HP, 208-230/460V	713010C-01
1	1	1	MOTOR, 15 HP, 575V	713807C-00
1	1	1	MOTOR PULLEY	003857X-00
1	1	1	BLOWER PULLEY	008137A-00
1	1	1	BELT (MATCHED PAIR)	701874A-04
1	1	1	BUSHING	008041X-00
	1	1	MOTOR, 20 HP, 208-230/460V	713004C-01
	1	1	MOTOR, 20 HP, 575V	713806C-00
	1	1	MOTOR PULLEY	003857X-00
	1	1	BLOWER PULLEY	422228X-00
	1	1	BELT (MATCHED PAIR)	701874A-05
2			TX VALVE	713029C-05
	2	2	TX VALVE	713029C-06
1	1	1	TR2, TRANSFORMER, (460V) 1 KVA — GAS UNIT	711412B-01
1	1	1	TR2, TRANSFORMER, (460V) 500 VA — ELECTRIC HEATING	714012D-02
1	1	1	TR2, TRANSFORMER, (460V) 300 VA — COOLING ONLY	714012D-01
1	1	1	TR2, TRANSFORMER, (575V) 1 KVA — GAS UNIT	382539E-29
1	1	1	TR2, TRANSFORMER, (575V) 500 VA — ELECTRIC HEATING	382539E-32
1	1	1	TR2, TRANSFORMER, (575V) 300 VA — COOLING ONLY	382539E-31
1	1	1	TR1, TRANSFORMER, 230/24V, 50VA — ALL UNITS	
1	1	1	TR3, TRANSFORMER, 230/24V, 50VA — GAS UNIT	712712B-01
1			C1, COMPRESSOR CONTACTOR, 3P, 50A WITH AUX., 230V, 460V & 575V UNITS	714004D-01
1			C2, COMPRESSOR CONTACTOR, 3P, 50A WITHOUT AUX., 230V UNITS ONLY	714010D-01
	1	1	C1, COMPRESSOR CONTACTOR, 3P, 75A WITH AUX., 230V, 460V & 575V UNITS	714008D-01
	1	1	C2, COMPRESSOR CONTACTOR, 3P, 75A WITHOUT AUX. 230V UNITS ONLY	714009D-01

① This is only a partial listing of the replacement parts available. Contact your local sales representative for additional information. Continued on next page



## PARTS LIST (Cont'd.) ①

QUANTITY PER UNIT			DESCRIPTION	PART NUMBER
CUR251	CUR300	CUR351		
<b>EVAPORATOR SECTION (CONTINUED)</b>				
1	1	1	BLOWER MOTOR CONTACTOR, 25A, 460V & 575V (7½, 10 & 15 HP)	714003D-01
	1	1	BLOWER MOTOR CONTACTOR, 40A, 460V & 575V (20 HP)	714001D-01
1			BLOWER MOTOR CONTACTOR, 25A, 230V (7½ HP)	714002D-01
1	1		BLOWER MOTOR CONTACTOR, 40A, 230V (10 HP)	714001D-01
1	1	1	BLOWER MOTOR CONTACTOR, 50A, 230V (15 HP)	714010D-01
	1	1	BLOWER MOTOR CONTACTOR, 75A, 230V (20 HP)	714009D-01
3	3	3	CONDENSER MOTOR CONTACTOR, 3P, 25A, 240V	714003D-01
1	1	1	EVAPORATOR MOTOR OVERLOAD RELAY, 7½, 10 & 15 HP MOTORS, 460V UNITS	714011D-01
1	1	1	EVAPORATOR MOTOR OVERLOAD RELAY, 7½ HP, 10HP, 15HP & 20 HP, 575V UNITS	714011D-01
	1	1	EVAPORATOR MOTOR OVERLOAD RELAY, 20 HP MOTOR, 460V UNITS	714011D-02
1			EVAPORATOR MOTOR OVERLOAD RELAY, 7½ HP MOTOR, 208-230V UNITS	714011D-01
1	1	1	EVAPORATOR MOTOR OVERLOAD RELAY, 10, 15 HP MOTORS, 208-230V UNITS	714011D-02
	1	1	EVAPORATOR MOTOR OVERLOAD RELAY, 20 HP MOTOR, 208-230V UNITS	714011D-03
3			HEATERS FOR OVERLOAD RELAY, 7½ HP (208-230V)	712044B-02
3			HEATERS FOR OVERLOAD RELAY, 7½ HP (460V)	712044B-14
3	3	3	HEATERS FOR OVERLOAD RELAY, 7½ HP (575V)	712044B-20
3	3	3	HEATERS FOR OVERLOAD RELAY, 10 HP (208-230V)	712044B-13
3	3	3	HEATERS FOR OVERLOAD RELAY, 10 HP (460V)	712044B-09
3	3	3	HEATERS FOR OVERLOAD RELAY, 10 HP (575V)	712044B-14
3	3	3	HEATERS FOR OVERLOAD RELAY, 15 HP (208-230V)	712044B-04
3	3	3	HEATERS FOR OVERLOAD RELAY, 15 HP (460V)	712044B-02
3	3	3	HEATERS FOR OVERLOAD RELAY, 15 HP (575V)	712044B-21
	3	3	HEATERS FOR OVERLOAD RELAY, 20 HP (208-230V)	712044B-15
	3	3	HEATERS FOR OVERLOAD RELAY, 20 HP (460V)	712044B-03
3	3	3	HEATERS FOR OVERLOAD RELAY, 20 HP (575V)	712044B-02
1	1	1	GUARD-A-MATIC (5 MINUTES)	712705B-01
3	3		F5-6-7, FUSE, BLOWER MOTOR, 208-230V, 7½ & 10 HP	258605C-10
3	3	3	F5-6-7, FUSE, BLOWER MOTOR, 208-230V, 15 HP	258605C-14
	3	3	F5-6-7, FUSE, BLOWER MOTOR, 208-230V, 20 HP	258605C-16
3	3		F5-6-7, FUSE, BLOWER MOTOR, 460V, 7½ & 10 HP	258604C-07
3	3		F5-5-7, FUSE, BLOWER MOTOR, 575V, 7½ & 10 HP	258604C-06
3	3	3	F5-6-7, FUSE, BLOWER MOTOR, 460V, 15 & 20 HP	258604C-10
3	3	3	F5-6-7, FUSE, BLOWER MOTOR, 575V, 15 & 20 HP	258604C-35
3	3	3	F8-9-10, FUSE, CONDENSER FAN, 20A, 250V (230V UNITS)	258605C-07
3	3	3	F8-9-10, FUSE, CONDENSER FAN, 10A, 600V (460V UNITS)	258604C-32
3	3	3	F8-9-10, FUSE, CONDENSER FAN, 8A, 600V (575V UNITS)	258604C-31
2	2	2	F3-4, FUSE, LINE CONTROL, 8A, 250V (230V GAS UNITS)	258605C-33
2	2	2	F3-4, FUSE, LINE CONTROL, 3.2A, 250V (230V ELECTRIC & COOLING ONLY UNITS)	258605C-32
2	2	2	F3-4, FUSE, LINE CONTROL, 3A, 600V (460V GAS & ELECTRIC UNITS)	497598B-09
2	2	2	F3-4, FUSE, LINE CONTROL, 2.5A, 600V (575V GAS & ELECTRIC UNITS)	497599B-08
2	2	2	F3-4, FUSE, LINE CONTROL, 1A, 600V (460V & 575V COOLING ONLY UNITS)	497598B-04
1	1	1	F1, FUSE, 24V CONTROL (ALL UNITS)	712038B-01
1	1	1	F2, FUSE, 24V CONTROL (VAV UNITS)	
<b>RELAYS, SPDT, 24V</b>				
3	3	3	R1-2-3, ALL UNITS	262130B-00
1	1	1	R1A, ALL VAV UNITS	
	1	1	R2A, ALL VAV UNITS	
1	1	1	R5, ELECTRIC HEAT & GAS HEAT OPTIONS	
1	1	1	PR, GAS HEAT OPTION	
1	1	1	RD, ECONOMIZER OPTION	
1	1	1	R7, SMOKE CONTROL OPTION, VAV	
<b>RELAYS</b>				
1	1	1	R4, ELECTRIC HEAT & GAS HEAT OPTIONS (DPDT, 24V)	711405B-01
1	1	1	R6, ELECTRIC HEAT & GAS HEAT, VAV (DPDT, 24V)	
1	1	1	RIK, ELECTRIC HEAT, VAV (DPDT, 24V)	
1	1	1	RU, VAV OPTION (SPNO, 24V)	711002A-01
1	1	1	R9, GAS HEAT, VAV (SPNO, 24V)	
1	1	1	R8, POWER EXHAUST OPTION (SPNO, 24V)	
2	2	2	RE & RS, SMOKE CONTROL OPTION (3PDT, 24V)	712710B-01

Continued on next page

① This is only a partial listing of the replacement parts available. Contact your local sales representative for additional information.

## PARTS LIST (Cont'd.) ①

QUANTITY PER UNIT			DESCRIPTION	PART NUMBER
CUR251	CUR300	CUR351		
<b>GAS HEATING SECTION</b>				
2	2	2	GAS VALVE (NATURAL)	712784B-01
2	2	2	GAS VALVE (PROPANE)	712785B-01
2	2	2	IGNITOR ELECTRODE & SENSOR	712783B-01
2	2	2	IGNITION CONTROL, SLAVE	712788B-01
2	2	2	FAN & LIMIT CONTROL	711961B-01
2	2	2	LIMIT SWITCH (BLOWER COMPARTMENT)	712005B-01
2	2	2	LIMIT SWITCH (FLAME ROLL-OUT)	712796B-02
2	2	2	VENTOR BLOWER WHEEL	711967B-01
2	2	2	VENTOR BLOWER HOUSING	711968B-01
2	2	2	VENTOR BLOWER MOTOR	711013A-01
6	6	6	FLUE GASKET (400 MBH FURNACE)	711976B-01
6	6	6	FLUE GASKET (500 MBH FURNACE)	713121C-01
38.5 ft.	38.5 ft.	38.5 ft.	BURNER & FLUE BOX GASKET	711974B-01
17.5 ft.	17.5 ft.	17.5 ft.	BURNER BOX COVER GASKET	711074A-01
<b>ECONOMIZER</b>				
1	1	1	DAMPER MOTOR SPRING RETURN, CONSTANT VOL. (WHITE RODGERS) ②	713020C-01
1	1	1	DAMPER MOTOR SPRING RETURN, VAV ONLY (HONEYWELL)	713054C-01
1	1	1	MINIMUM POSITION POTENTIOMETER, VAV ONLY	713024C-01
1	1	1	CRANKARM FOR HONEYWELL MOTOR	711980B-01
1	1	1	CRANKARM FOR WHITE RODGERS MOTOR	711048A-01
1	1	1	ENTHALPY CONTROL	712011B-01
4	4	4	PRE-AIR FILTER (PERMANENT)	712070B-01
<b>PUMPDOWN, SUCTION LINE FILTER, HOT GAS BYPASS &amp; POWER EXHAUST</b>				
2			LSV, CLSV, SOLENOID VALVE & COIL	703017B-03
	2	2	LSV, CLSV, SOLENOID VALVE & COIL	703017B-04
1	1		HOT GAS BYPASS SOLENOID VALVE & COIL	703017B-04
		1	HOT GAS BYPASS SOLENOID VALVE & COIL	703017B-05
1			SUCTION LINE FILTER	713043C-03
	1	1	SUCTION LINE FILTER	713043C-04
	2	2	FLEX COUPLING, SLEEVE	712053B-01
	1	1	FLEX COUPLING, INSERT	712054B-01
1	1	1	FIRESTAT, 135°F, RETURN AIR	712001B-01
<b>VARIABLE AIR VOLUME</b>				
1	1	1	DISCHARGE AIR CONTROLLER (W7100C)	713022C-01
1	1	1	DISCHARGE AIR SENSOR	713021C-01
1	1	1	DIFFERENTIAL PRESSURE SWITCH	497578B-01
1	1	1	DISCHARGE/RETURN DAMPER MOTOR	713053C-01
1	1	1	TRANSFORMER (DAMPER MOTOR)	712713B-01
1	1	1	TRANSFORMER, 230/24V, 50VA	712712B-01
<b>FAILURE STATUS OPTION RELAYS</b>				
2	2	2	RC1 & RF, ALL UNITS (SPDT, 208-230V)	712707B-01
1	1	1	RH, ELECTRIC HEAT UNITS (SPDT, 208-230V)	
2	2	2	RH1 & RH2, GAS HEAT UNITS (SPDT, 24V)	262130B-00

① This is only a partial listing of the replacement parts available. Contact your local sales representative for additional information.

② When replacing Honeywell spring return motor with a White Rodgers motor, the crankarm must also be ordered.

## SERVICE & WARRANTY PROCEDURE

### MOTOR COMPRESSOR

Copeland Refrigeration Corporation has stocking wholesalers who maintain a stock of replacement motor compressors and service parts to serve refrigeration contractors and service personnel as required.

When a motor compressor fails in warranty, the inoperative compressor can be taken to any authorized Copeland wholesaler for an over-the-counter exchange or an advance replacement may be obtained. Credit is issued by the wholesaler for the returned compressor upon receipt and Copeland factory inspection of the inoperative compressor. If that compressor is out of Copeland's warranty, a salvage credit only is allowed. Provide your local sales representative or the SnyderGeneral factory Warranty Claims Department with full details including the unit model and serial numbers, the invoice and the salvage value credit memo copies. SnyderGeneral Corporation will reimburse the difference. In this transaction be certain that the motor compressor is definitely defective. If a compressor is received from the field that tests satisfactorily, a service fee plus a transportation fee will be charged against its original credit value.

On all out of warranty motor compressor failures, Copeland offers the same field facilities for service and/or replacement as described above. The credit issued on the return compressor will be determined by the repair charge established for that particular unit.

### IN-WARRANTY RETURN MATERIAL PROCEDURE

Material other than compressors may not be returned except

by permission of authorized factory service personnel. Contact your local sales representative for further "who to contact" information.

A "return goods" tag will be sent to be included with the returned material. Enter the information as called for on the tag in order to expedite handling at our factories and prompt issuance of credits. All parts shall be returned to the factory designated on the return goods tag, transportation charges prepaid.

The return of the part does not constitute an order for replacement. Therefore, a purchase order must be entered through your nearest sales representative. The order should include part number, model number, and serial number of the unit involved.

Following our personal inspection of the returned part and if it is determined that the failure is due to faulty material or workmanship, credit will be issued on customer's purchase order.

### REPLACEMENT PARTS

Replacement parts may be obtained by contacting your local sales representative or parts distributor. If you do not know who to contact, call SnyderGeneral Corporation at (612) 553-5009 for assistance. Refer to the model number and serial number of the unit as stamped on the serial plate attached to the unit. If replacement parts are required, mention the date of installation of the unit and the date of failure, along with an explanation of the malfunctions and a description of the replacement parts required.

## PRODUCT WARRANTY — CUR 251E, 300E, 351E

SnyderGeneral Corporation, hereinafter referred to as the "Company," warrants that it will provide, at the Company's option, either free replacement parts or free repair of component parts in the event any product manufactured by the Company and used in the United States proves defective in material or workmanship within twelve (12) months from initial startup or eighteen (18) months from the date shipped by the Company, whichever comes first. For additional consideration, SnyderGeneral Corporation warrants that for four (4) years following the initial warranty period it will provide, at the Company's option, free replacement parts for the motor-compressor, or, free replacement for any integral component of the motor-compressor which proves defective in material or workmanship. For an additional consideration, SnyderGeneral Corporation warrants that for nine (9) years following the initial warranty period it will provide free replacement of the heat exchanger in gas-fired or oil-fired furnaces which proves defective in material and workmanship. (Extended warranties for motor-compressors and heat exchangers are not applicable unless separately purchased.)

To obtain assistance under this parts warranty, extended motor-compressor warranty, or extended heat exchanger warranty, simply contact the selling agency. To obtain information or to gain factory help: For brandnames Arcoaire and/or Comfortmaker contact SnyderGeneral Corporation, Warranty Department, 302 Nichols Drive, Hutchins, TX 75141, telephone (214) 225-7351. For McQuay, Climate Control, Barry Blower and JennFan brandnames, contact SnyderGeneral Corporation, Warranty Claims Department, P. O. Box 1551, Minneapolis, MN 55440, telephone (612) 553-5330.

**THIS WARRANTY CONSTITUTES THE BUYER'S SOLE REMEDY. IT IS GIVEN IN LIEU OF ALL OTHER WARRANTIES.**

**TIES. THERE IS NO IMPLIED WARRANTY OF MERCHANTABILITY OR FITNESS FOR A PARTICULAR PURPOSE. IN NO EVENT AND UNDER NO CIRCUMSTANCES SHALL SNYDERGENERAL CORPORATION BE LIABLE FOR INCIDENTAL OR CONSEQUENTIAL DAMAGES, WHETHER THE THEORY BE BREACH OF THIS OR ANY OTHER WARRANTY, NEGLIGENCE OR STRICT TORT.**

This parts warranty and the optional extended warranties extend only to the original user. Of course, abuse, misuse, or alteration of the product in any manner voids the Company's warranty obligation. Neither the parts or extended warranty obligates the Company to pay any labor or service costs for removing or replacing parts, or any shipping charges. Refrigerants, fluids, oils, and expendable items such as filters are not covered by this warranty.

The extended warranties apply only to integral components of the motor-compressor or heat exchanger, not to refrigerant controls, electrical controls, or mechanical controls, or to failures caused by failure of those controls.

Attached to this warranty is a requirement for equipment containing motor-compressors and/or furnaces to report start-up information. The registration form accompanying the product must be completed and returned to SnyderGeneral Corporation within ten (10) days of original equipment start-up. If that is not done, the date of shipment shall be presumed to be the date of start-up and the warranty shall expire twelve (12) months from that date.

No person (including any agent, salesman, dealer or distributor) has authority to expand the Company's obligation beyond the terms of this express warranty, or to state that the performance of the product is other than that published by SnyderGeneral Corporation.

**SnyderGeneral**

Corporation

13600 Industrial Park Blvd., P.O. Box 1551, Minneapolis, MN 55440

(612) 553-5330