



**duraSchwank Models
SPW-JZ, STW-JZ(S)**

&

**Models
IWP, IW(-S)**

**OUTDOOR, CAR WASH & WET ENVIRONMENT
LOW INTENSITY TUBE TYPE INFRA RED HEATERS**

INSTALLATION / OWNER'S MANUAL



WARNING Improper installation, adjustment, alteration, service or maintenance can cause property damage, injury or death. Read the installation and operating and maintenance instructions thoroughly before installing or servicing this equipment.

SAFETY ALERT:

This heater must be installed and serviced only by a trained gas service technician. Failure to comply could result in personal injury, death, fire and/or property damage.

Do not store or use gasoline or other flammable vapours and liquids in the vicinity of this or any other gas fired appliance.

IF YOU SMELL GAS:

- Extinguish any open flame
- Do not attempt to light this or any other appliance
- Don't touch any electrical switch, or telephone
- Immediately call your gas supplier from a neighbor's phone
- Follow any and all instruction from your gas supplier
- If your gas supplier is not available, call the fire department



**Keep this manual in a secure place .
Record for future reference:**

Model #: _____

Serial #: _____

(located on heater rating label)

GAS-FIRED



NOTICE:

This manual is current for this product. Occasional revision of the product Certification Standard may require changes to the product and/or this manual.

This publication, or parts thereof, may not be reproduced in any form, without prior written consent from The Manufacturer. Unauthorized use or distribution of this publication is strictly prohibited.

Schwank Group

Schwank and InfraSave brands

5285 Bradco Boulevard

Mississauga, Ontario, L4W 2A6

PO Box 988, 2 Schwank Way

Waynesboro, Georgia 30830

Customer & Technical Services

Phone: 877-446-3727

Fax: 866-361-0523

e-mail: csr@schwankgroup.com

www.schwankgroup.com

www.infrasave.com

SPW-JZ / IWP, and STW-JZ(S) / IW(S) SERIES CAR WASH & WET ENVIRONMENT LOW INTENSITY TUBE TYPE INFRA RED HEATERS

TABLE OF CONTENTS

TOPIC PAGE	TOPICPAGE
<u>INSTALLATION</u>			
<i>IMPORTANT INFORMATION - READ FIRST</i>			
	4		
APPLICATION	4		
HEATER EXPANSION	5, 31		
GAS CONNECTION	5, 31		
See also "Flexible Gas Connection"	31		
VENTING	5, 26		
START UP 'SMOKE'	5		
CLEARANCE TO COMBUSTIBLES	6		
Clearances Figure & Table	7		
STACKING HEIGHT SIGN	8		
1. LABOR REQUIREMENTS	9	12. COMBUSTION AIR DUCT	35
2. INSTALLATION IN AIRCRAFT HANGARS	9	13. GAS SUPPLY / HEATER EXPANSION / FLEXIBLE GAS CONNECTION	36 - 38
3. INSTALLATION IN COMMERCIAL GARAGES	9	14. ELECTRICAL AND THERMOSTAT	39
4. INSTALLATIONS OTHER THAN SPACE HEATING	9	15. HIGH ALTITUDE INSTALLATION	39
5. PRE-INSTALLATION SURVEY	10	16. LIGHTING INSTRUCTIONS	39
6. MOUNTING CLEARANCES	11	17. RECOMMENDED MAINTENANCE	39
SERVICE CLEARANCE	11	18. WIRING DIAGRAM	40
HEATER PLACEMENT GUIDELINES	12	19. WIRING DIAGRAM MULTIPLE HEATERS PER THERMOSTAT	41
7. SYSTEMS WITH 90° & 180° ELBOWS..	12 - 16	20. SEQUENCE OF OPERATION	42
. ELBOW KIT DIMENSIONS	13, 50	21. TROUBLESHOOTING GUIDE	43
8. SUSPENDING THE SYSTEM	17	22. SPARK IGNITION CIRCUIT	45
8A SEISMIC RESTRAINT	20	SPARK IGNITER SET UP	45
8B HIGH WIND RESTRAINT	20	24. START- UP / COMMISSIONING SHEET	46
9. BURNER & TUBE INSTALLATION	21		
TURBULATOR LENGTH/LOCATION	24	<u>PRODUCT DIMENSIONS & DATA</u>	
SPECIAL COUPLING - 100, 175 & 200 Mbh..	26	25. HEATER DIMENSIONS / WEIGHTS	48
10. REFLECTOR INSTALLATION	26	INSTALLATION DIMENSIONS	49
11. FLUE VENTING	29	26. BURNER / TUBE KIT ASSEMBLY CHARTS ALUMINIZED STEEL TUBE KITS	50
COMBINED SYSTEM LENGTH	30	28. HIGH ALTITUDE INSTALLATION	51
HEATER EXPANSION / VENT CONFIGURATION	31	29. HIGH ALTITUDE ORIFICE CHART	52
VERTICAL VENT THRU ROOF	32	30. OPTIONAL ACCESSORIES	53 - 55
HORIZONTAL VENT THRU WALL	33	31. BURNER PARTS LIST	56 - 58
		TUBE SYSTEM PARTS LIST	59
		WARRANTY STATEMENT	BACK PAGE



WARNING

Improper installation, adjustment, alteration, service or maintenance can cause property damage, injury or death. Read and



understand this installation and operation manual thoroughly prior to assembly, installation, operation or service to this appliance.

This heater must be installed and serviced only by a trained gas service technician.



Do not store or use gasoline or other flammable vapours and liquids in the vicinity of this or any other gas fired appliance.

Failure to comply could result in personal injury, death, fire and/or property damage.



Do not store or use gasoline or other flammable vapours and liquids in the vicinity of this or any other gas fired appliance.

This appliance may have sharp edges and corners. Wear protective clothing such as gloves and protective eye wear when servicing this or any other appliance.

California Proposition 65:



WARNING: This product can expose you to chemicals including carbon monoxide, which is known to the State of California to cause birth defects or other reproductive harm. For more information, go to www.P65Warnings.ca.gov

APPLICATION

This model is approved for indoor and outdoor installation. A gas-fired radiant tube heater may be installed for heating of commercial / industrial non-residential spaces. It is beyond the scope of these instructions to consider all conditions that may be encountered. Installation must conform with all local building codes or, in the absence of local codes, with the National Fuel Gas Code, ANSI Z223.1/NFPA 54 in the U.S.A. or the Natural Gas and Propane Installation Code, CSA B149.1 in Canada. The latest edition Electrical Code ANSI/NFPA N0 70 in the U.S.A. and PART 1 CSA C22.1 in Canada must also be observed.

Installation of a gas fired tube heater must conform to all heating installation design procedures including clearance to combustibles, connection to the gas and electrical supplies, and ventilation.

This heater is not for installation in a Class 1 or Class 2 explosive environment, nor a residence. If installation of this equipment is in question, consult with local authorities having jurisdiction (Fire Marshall, labor department, insurance underwriter, or others).

Revisions to codes and/or standards, may require revision to equipment and installation procedures. In case of discrepancy, the latest codes, standards, and installation manual will take priority over prior releases.

Models SPW-JZ and IWP have a powder coated water resistant burner enclosure and aluminumized steel tube/reflector system. These models may be installed to heat commercial / industrial non-residential outdoor spaces and wet indoor environments.

Models STW-JZ and IW have a stainless steel water resistant burner enclosure and aluminumized steel tube/reflector system, and may be installed for heating of commercial / industrial non-residential outdoor spaces and wet indoor environments.

Models STWS and IWS have a stainless steel water resistant burner enclosure and stainless steel tube/reflector system for heating of harsh indoor/outdoor environments.

CERTIFICATION: MODELS SPW-JZ, STW-JZ, STWS, IWP, IW, IWS

These model tube heaters are certified to:

- ANSI Z83.20 / CSA 2.34 Standard for Gas-Fired Low Intensity Infrared Heaters
- ANSI Z83.26 / CSA 2.37 Standard for gas-Fired Outdoor Infrared Patio Heaters



WARNING

Heater Expansion



It is a normal condition that during heat-up and cool-down a tube heater will expand and contract. Allowances for heater expansion must be made in the gas connection, venting and combustion air ducting. Improper installation, alteration, or adjustment can result in property damage, injury or death. **Refer to Section 13**



WARNING

Gas Connection



Improper installation, connection, or adjustment can result in property damage, toxic gases, asphyxiation, injury or death. Using an approved flexible gas connector in the USA or Type 1 hose connector in Canada, the gas supply to the heater must be connected and tested in accordance with all local, state, provincial, and national codes (ANSI Z223.1/NFPA 54 in USA; B149.1 in Canada) and as indicated in this manual. **Refer to Section 13**



WARNING

Venting



Inadequate venting of a heater may result in asphyxiation, carbon monoxide poisoning, injury or death. This heater may be directly or indirectly vented from the space. Venting must be in accordance with all local, state, provincial, and national codes (ANSI Z223.1/NFPA 54 in USA; B149.1 in Canada) and as indicated in this manual. **Refer to Sections 11 & 12**



WARNING

Start-Up 'SMOKE' Condition

During start up, the heating of material coatings used in the production process of tubes and reflectors will create smoke during the initial period of operation. This condition is normal and temporary .

Ensure that there is sufficient ventilation to adequately clear any smoke from the space.

Notify site and safety personnel to ensure that alarm systems are not unduly activated.



WARNING

Clearance to combustibles

Location of flammable or explosive objects, liquids or vapors close to the heater may cause fire or explosion and result in property damage, injury or death. Do not use, store or locate flammable or explosive objects, liquids or vapors in proximity of the heater.



The clearance to combustible material represents the minimum distance that must be maintained between the outer heater surface and a nearby surface. The stated clearance to combustibles represents a surface temperature of 90F° (50C°) above room temperature. It is the installer's responsibility to ensure that building materials with a low heat tolerance which may degrade at lower temperatures are protected to prevent degradation. Examples of low heat tolerance materials include vinyl siding, fabrics, some plastics, filmy materials, etc.

In locations used for the storage of combustible materials, signs must be posted to specify the maximum permissible stacking height to maintain the required clearances from the heater to the combustibles. Such signs must either be posted adjacent to the heater thermostats or in the absence of such thermostats in a conspicuous location. In addition to stored or stationary material, consideration must also be given to moveable objects such as cranes, vehicles, and overhead doors, and structural objects such as sprinkler heads, electrical and gas lines, and electrical fixtures.

It is beyond the scope of these instructions to consider all conditions that may be encountered. Consult local authorities such as the Fire Marshall, insurance carrier, or safety authorities if you are uncertain as to the safety or applicability of the proposed installation.

Refer to Figure 1 and Table 1 for the certified clearances to combustibles for the appropriate model input/size.

FIGURE 1 MINIMUM CLEARANCES TO COMBUSTIBLES* - refer to Table 1 for values

NOTE: A 'PEEL & STICK' SIGN IS SUPPLIED: USE AN INDELIBLE MARKER TO ENTER VALUES 'H', 'S', 'F', & 'B' ON THE SIGN.
 POST THE SIGN ADJACENT TO THE HEATER THERMOSTAT OR IN A PROMINENT LOCATION. See next page for details.

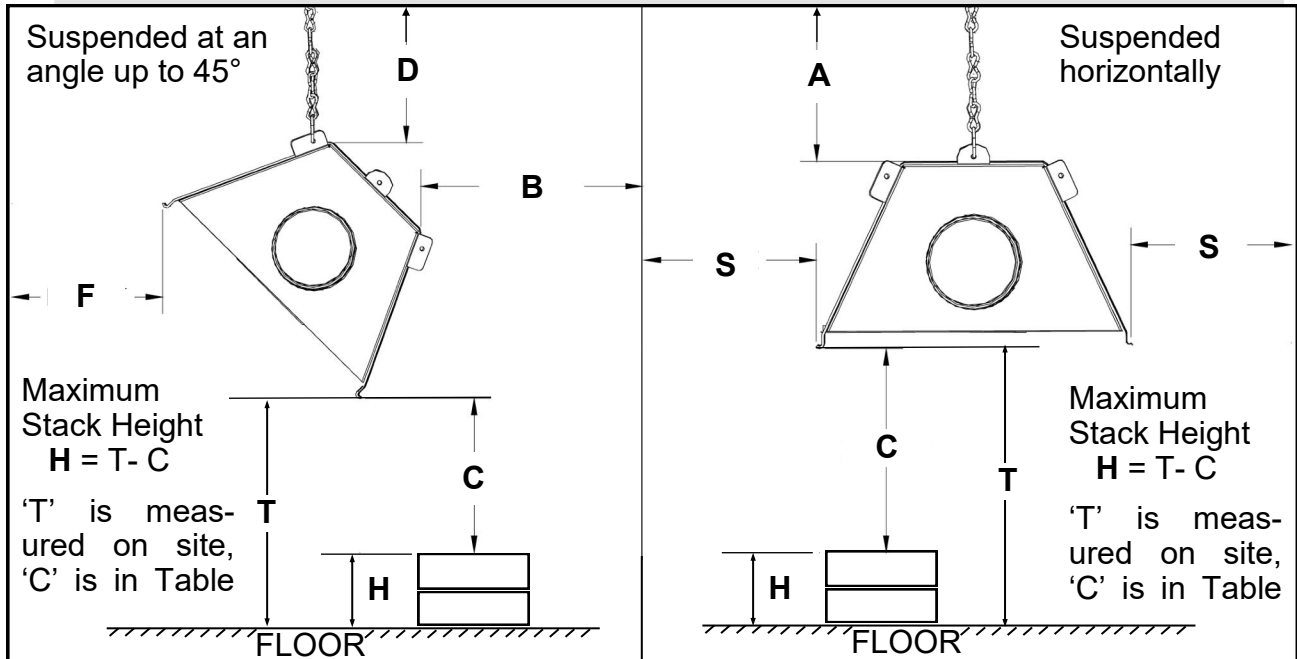

TABLE 1 MINIMUM CLEARANCES TO COMBUSTIBLES*

MODELS: SPW-JZ / IWP STW-JZ / IW STWS / IWS	SUSPENDED AT AN ANGLE UP TO 45 DEGREES				SUSPENDED HORIZONTALLY		
	D inches (cm)	B inches (cm)	F inches (cm)	C inches (cm)	A inches (cm)	S inches (cm)	C inches (cm)
200,000	13 (33)	6 (15.2)	74 (188)	70 (178)	14 (36)	44 (112)	76 (193)
175,000	12 (31)	6 (15.2)	72 (183)	68 (172)	13 (33)	42 (107)	74 (188)
150,000	5.5 (14)	1 (2.5)	64 (163)	64 (163)	3.5 (9)	22 (48)	70 (178)
125,000	4.5 (11)	1 (2.5)	60 (152)	60 (152)	3.3 (9)	21 (28)	65 (165)
110,000	3.5 (9)	1 (2.5)	54 (137)	54 (137)	2 (5)	19 (25)	60 (137)
80,000	3 (8)	1 (2.5)	23 (59)	38 (97)	1.75 (5)	6 (15)	38 (97)
60,000	2.5 (6)	1 (2.5)	17 (43)	34 (86)	1.5 (4)	5.5 (14)	34 (86)
45,000	2.75 (7)	1 (2.5)	24 (61)	32 (81)	2.25 (6)	7 (18)	32 (81)

*The clearance to combustible materials represents the minimum distance that must be maintained between the heater and a nearby surface. The stated clearance to combustibles represents a surface temperature of 90F° (50C°) above room temperature.

NOTE that in the above table the clearances are measured from the reflector.

It is the installer's responsibility to ensure that building materials with a low heat

tolerance which may degrade at lower temperatures are protected to prevent degradation. Examples of low heat tolerance materials include vinyl siding, fabrics, some plastics, filmy materials, etc.

VENT END CLEARANCE: Clearances from the vent pipe are determined by local or national installation codes, but must not be less than 6 inches (15 cm). For 'unvented' installation, a minimum distance of 24 inches (61 cm) is required from the end of heater to a combustible surface.



WARNING In locations used for the storage of combustible materials: Signs must be posted specifying the *maximum permissible stacking height* to maintain the required clearances from the heater to the combustibles.

The signs must be posted either adjacent to the IR heating system thermostats or in the absence of such thermostats, in a conspicuous place.

For your convenience a “peel and stick” sign is provided with this heater. Use a permanent marker to record the required dimensions on the sign.

To calculate the value 'H': $(H = T - C)$

- Measure the on site distance between bottom of the heater and the floor = 'T' inches (cm).
- Refer to Table 1 to get the value 'C' that corresponds to the model you are installing
- Subtract the clearance below the heater 'C' from 'T' to get value 'H'.
- Enter this value 'H' on the sign.

Refer to the information for the heater model being installed in Figure 1 and Table 1 to get the values for dimensions 'S', 'F' and 'B'.

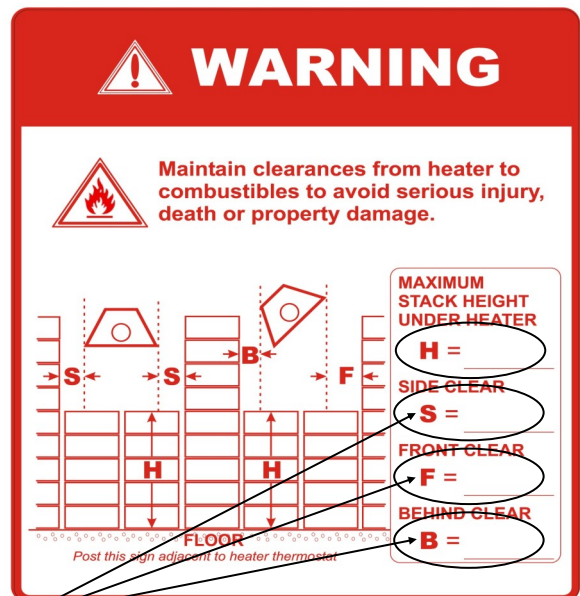

Post this sign as instructed above.

1. LABOR REQUIREMENTS

Two persons are required to safely install this equipment. Wear gloves and other required safety protection.

2. INSTALLATION IN COMMERCIAL AIRCRAFT HANGARS

Low intensity radiant tube heaters are suitable for use in aircraft hangars when installed in accordance with the latest edition of the Standard for *Aircraft Hangars*, ANSI/NFPA No 409 in the USA, or the Canadian *Natural Gas and Propane Installation Code*, B149.1.

- A. A minimum clearance of 10 ft (3 m) above either the highest fuel storage compartment or the highest engine enclosure of the highest aircraft which may occupy the hangar. The clearance to the bottom of the heater shall be measured from the upper surface of either the fuel storage compartment or the engine enclosure, whichever is higher from the floor.
- B. A minimum clearance of 8 ft (2.4 m) must be maintained from the bottom of the heater to the floor in other sections of the aircraft hangar, such as offices and shops, which communicate with areas for servicing or storage. Refer to Table 1 for proper mounting clearances to combustibles.
- C. Heaters must be located so as to be protected from damage by aircraft and other objects, such as cranes and movable scaffolding.
- D. Heaters must be located so as to be accessible for servicing and adjustment.

3. INSTALLATION IN COMMERCIAL GARAGES AND PARKING STRUCTURES

Low Intensity Heaters are suitable for use in commercial garages when installed in accordance with the latest edition of the Standard for *Parking Structures*, ANSI/NFPA 88A, or the Standard for *Repair Garages*, ANSI/NFPA No. 88B, or the Canadian *Natural Gas and Propane Installation Code*, B149.1.

	<p>WARNING An overhead heater shall be located high enough to maintain the minimum distance to combustibles, as shown on the heater rating plate, from the heater to any vehicles parked below the heater.</p> <p>Overhead heaters shall be installed at least 8 ft (2.4 m) above the floor.</p>
---	---

4. INSTALLATIONS OTHER THAN SPACE HEATING

Use for process or other applications that are not space heating will void the C.S.A. certification and product warranty. Process application requires field inspection and/or certification by local authorities having jurisdiction.



WARNING



Improper installation, adjustment, alteration, service or maintenance can cause property damage, injury or death. Read and understand this installation and operation manual thoroughly prior to assembly, installation, operation or service to this appliance.



This heater must be installed and serviced only by a trained gas service technician.

Do not store or use gasoline or other flammable vapours and liquids in the vicinity of this or any other gas fired appliance.



Failure to comply could result in personal injury, death, fire and/or property damage.

Do not store or use gasoline or other flammable vapours and liquids in the vicinity of this or any other gas fired appliance.

5. PRE INSTALLATION SURVEY

It is recommended that a full heating design including heat loss calculation be conducted on the structure or area to be heated. Heater sizing and placement must consider available mounting height, sources of greatest heat loss, and the certified clearances to combustibles with respect to stored material, moveable objects (cranes, vehicles, lifts, overhead doors, etc), sprinkler system heads, and other obstructions on the site. Consideration must also be given to vent / duct placement and the allowable combined lengths of vent and duct. Carefully survey the area to be heated, and for best results place burner and combustion chamber in the coldest area(s) .

Installation must conform with all local, state, provincial and national code requirements including the current latest edition ANSI Z223.1 (NFPA 54) in the U.S.A. and B149.1 installation code in Canada, for gas burning appliances and equipment. The latest edition Electrical Code ANSI/NFPA N0 70 in the U.S.A. and PART 1 CSA C22.1 in Canada must also be observed.

The heating system must have gas piping of the correct diameter, length, and arrangement to function properly. For this reason, a layout drawing is necessary.

6. MOUNTING CLEARANCES

This heater must be mounted with at least the minimum clearances between the heater and combustibles as shown in FIG-1, TABLE 1, Page 7. It is the installer's responsibility to ensure that building materials with a low heat tolerance which may degrade at lower temperatures are protected to prevent degradation. Examples of low heat tolerance materials include vinyl siding, fabrics, some plastics, filmy materials, etc.

Positioning of lights, sprinkler heads, overhead doors, storage areas, gas and electrical lines, parked vehicles, cranes and any other possible obstruction or hazard must be evaluated prior to installation.

Ensure adequate clearance around the air intake at the burner to allow sufficient combustion air supply to the heater.

6A. SERVICE CLEARANCE: The lower 'jaw' of the burner cabinet swings down to provide convenient service access to burner components. Provide a minimum clearance from any wall or obstruction of 6 inches (15 cm) to the access end of the burner housing, and a minimum of 24 inches (61 cm) to any ONE side to allow servicing of burner, blower and controls. (see Figure 2 below) - the minimum clearances to combustibles must always be maintained.

For guidelines to heater placement refer to TABLE 2 (next page).

FIGURE 2

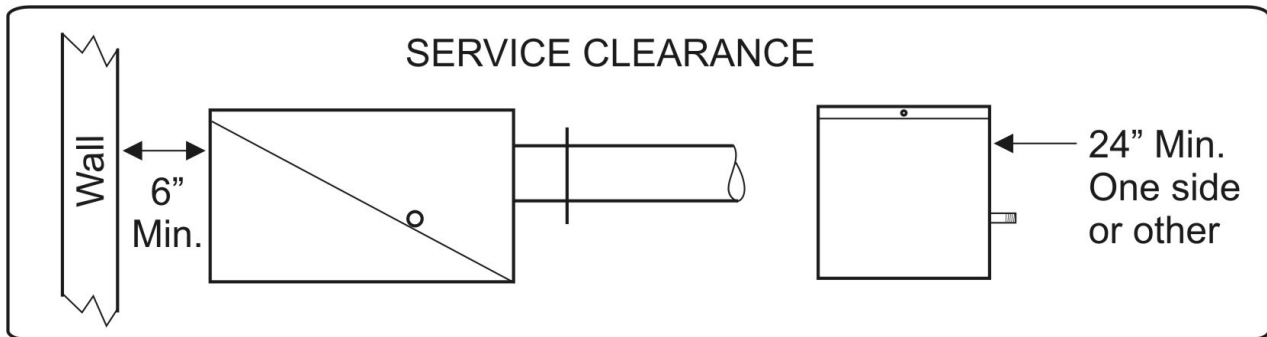



TABLE 2: GUIDELINES FOR HEATER PLACEMENT: INDOOR SPACE HEATING

MODELS: SPW-JZ / IWP STW-JZ / IW STWS / IWS	MOUNTING HEIGHT ft (m)	MAXIMUM DISTANCE BETWEEN HEATERS ft (m)	DISTANCE – OUTSIDE WALL TO HEATER LONG AXIS (PARALLEL TO WALL) IN “FEET”	
			HORIZONTAL ft (m)	ANGLE
200,000	18 – 25 (6 - 8)	50 (15)	17 – 25 (5 - 8)	COMBUSTIBLE CLEARANCE BEHIND (refer to Table 1)
175,000	18 – 25 (6 - 8)	50 (15)	17 – 25 (5 - 8)	
150,000	16 – 21 (5 - 7)	45 (14)	15 – 20 (5 - 7)	
125,000	15 – 21 (5 - 7)	40 (12)	15 – 20 (5 - 7)	
110,000	13 – 19 (4 - 6)	35 (11)	13 – 18 (4 - 6)	
80,000	10 – 16 (3 - 5)	30 (9)	12 – 16 (4 - 5)	
60,000	8 – 14 (2.5 - 5)	25 (8)	11 – 15 (3.4 - 5)	
45,000	8 – 12 (2.5 - 4)	20 (6)	8 – 12 (2.5 - 4)	

* GUIDELINE MOUNTING HEIGHTS are typical to provide optimum comfort in general indoor-space heating applications. Variance to these typical heights can occur in some applications:

- Higher mounting heights due to structure or application requirements
- Lower mounting heights for area or ‘spot’ heat indoor or , or in areas with greater infiltration losses (near overhead doors, etc)



IMPORTANT: Single or multiple heater placement must be such that continuous operation of heater(s) will not cause combustible material or materials in storage to reach a temperature in excess of ambient temperature plus 90F° (50C°).

It is the installer’s responsibility to ensure that building materials with a low heat tolerance which may degrade at lower temperatures are protected to prevent degradation. Examples of low heat tolerance materials include vinyl siding, fabrics, some plastics, filmy materials, etc.

Refer to “Clearance to Combustibles” information on pages 6 to 8, and Figure 1 and Table 1.

7. SYSTEMS INCORPORATING 90° ELBOWS AND 180° ELBOWS

The radiant tube heater can be installed in configurations as illustrated in FIGURE 4. (below) with a maximum of two 90° elbows per heater. The use of elbows reduces the total maximum vent allowable. (See Section 11 : Flue venting)

90° elbows (JS-0528-JZ) are shipped as a kit with one coupler, one reflector and one plate hanger. For a 180° elbow, order 2 x 90° kits that connect to create a 180°. An optional kit (JS-0504-JZ) to angle mount a reflector adjacent to an elbow is also available and must be ordered separately. The reflectors must be secured to each of the elbow plate hangers, See PAGE 16

IMPORTANT: Models with input 100 Mbh x 20 ft (30 kW x 6 m) must only be installed as a straight system with no elbows allowed at the 10 ft (3 m) location.



Elbow Location / Input: A minimum run of straight radiant tube must be connected to the burner before any elbow as follows: Inputs 200 (60 kW) and 175 Mbh (50 kW) = 25 ft (7.6 m); Input 150 Mbh (45 kW) = 20 ft (6 m); Inputs 125 Mbh (38 kW) and 110 Mbh (32 Kw) = 15 ft (4.6 m); and Inputs 80 Mbh (23 kW), 60 Mbh (18 kW), and 45 Mbh (13 kW) a minimum of 10 ft (3 m) straight tube before elbow.

FIGURE 3 SYSTEM ELBOW KIT - see page 50 for 180° elbow dimensions

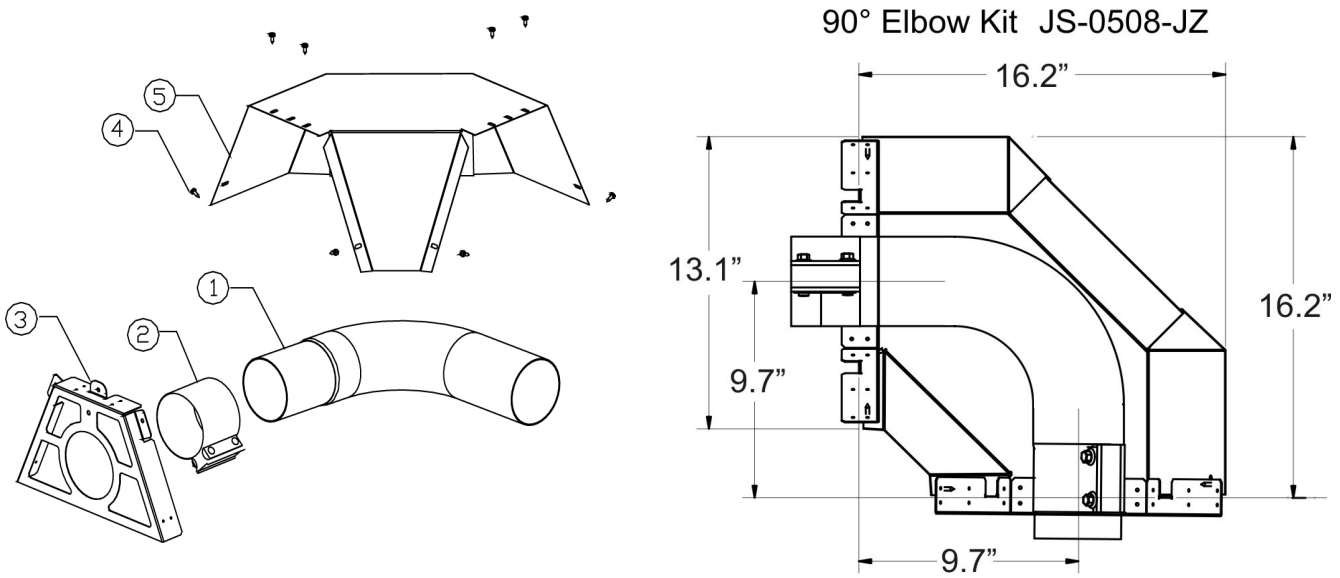

Angle mounting of the reflector system either side of an elbow requires adapter JS-0504-JZ. The elbow always remains in a horizontal orientation.

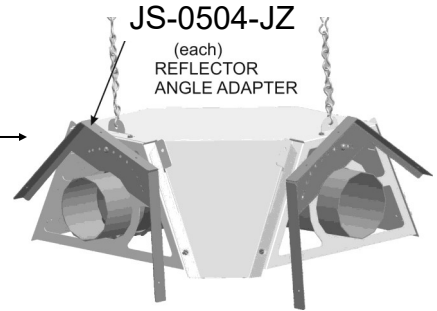
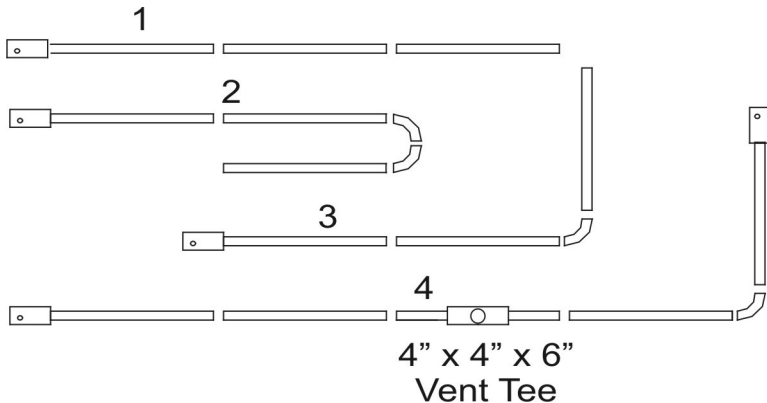

FIGURE 4 SYSTEM CONFIGURATIONS



System Configuration

- 1 Straight line
- 2 "U" tube with 2 x 90° elbow kits
- 3 "L" tube with one 90° elbow kit
- 4 Twinned tubes into common TEE flue vent

INSTALLATION INSTRUCTIONS FOR 90° AND 180° ELBOW KITS

When installing systems that incorporate a 90° or 180° elbow, assembly of the system is facilitated by first locating and installing the elbow assembly, then install the remainder of the tube/reflector system working away from the elbow.

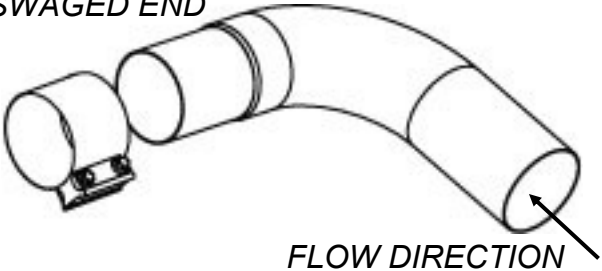
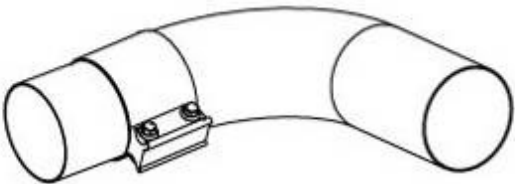
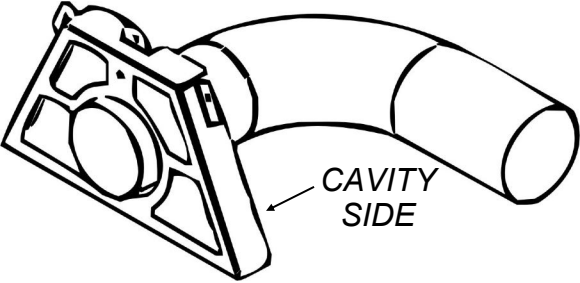
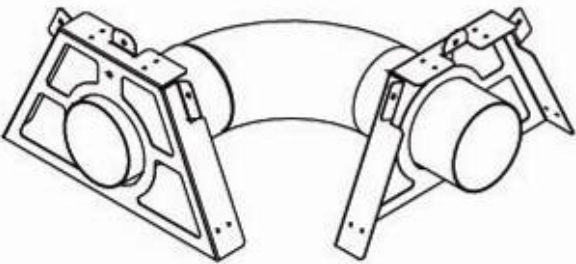
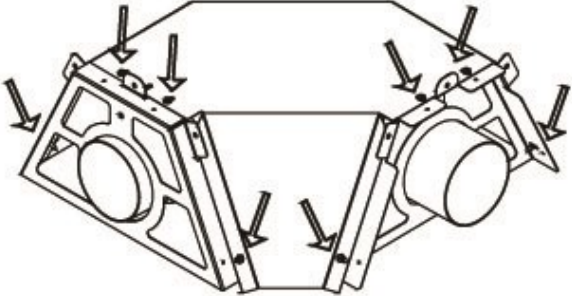
<p>SWAGED END</p>  <p>FLOW DIRECTION</p>	<p><u>90° ELBOW KIT ASSEMBLY</u></p> <p>#1 Add the coupler to the 90° elbow over the swaged end of the elbow.</p>
	<p>#2 Slacken the coupler bolts. Slide the coupler over the elbow from the swaged end.</p>
 <p>CAVITY SIDE</p>	<p>#3 Add the plate hanger to the system Important: the plate hanger must be installed with the cavity side facing upstream toward the burner.</p>
	<p>#4 Install the next plate hanger (supplied with tube kit) over the unswaged end of the elbow with the cavity side facing upstream toward the burner. (Not to be reversed)</p>
	<p>#5 Place the reflector over the plate hangers. Secure reflector to hangers with sheet metal screws provided.</p>

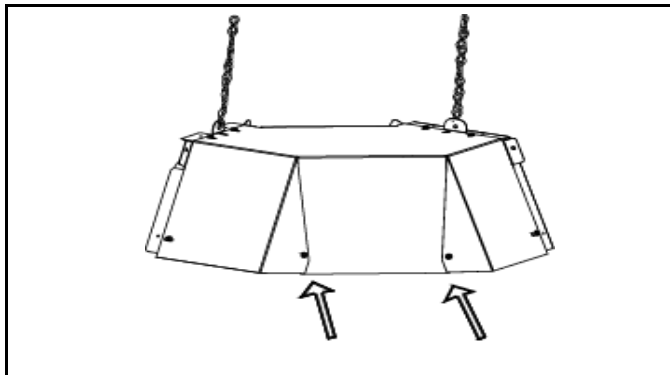

#6

After installation of the elbow assembly, fasten the corners of the reflector cover with the 2 screws provided.

For 90° installation finish with step # 7

For 180° installation skip # 7 and proceed to step # 8

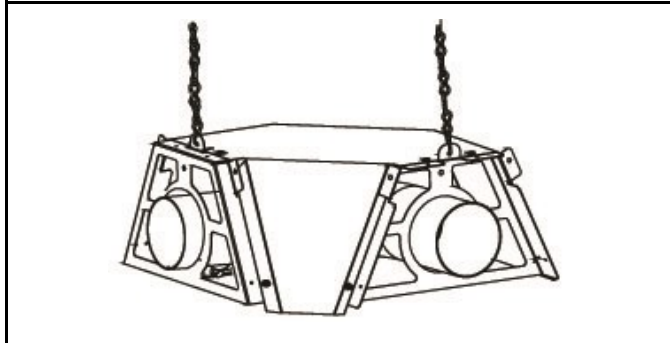

#7

Suspending the elbow kit in horizontal position prepared for tube installation in horizontal mode.

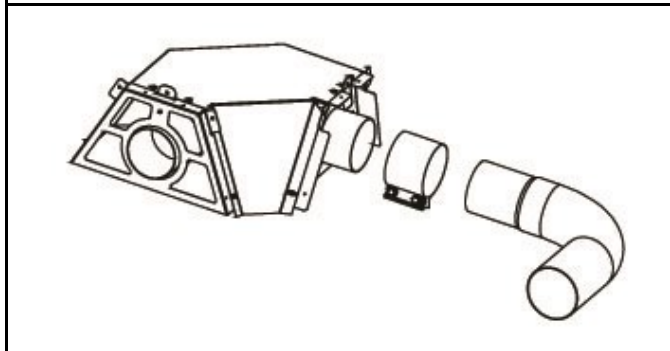

#8

180° ELBOW KIT ASSEMBLY

Add the second coupler to the 90° elbow kit to form 180° elbow kit

Slacken the bolts and slide the coupler over the elbow at the swaged end.

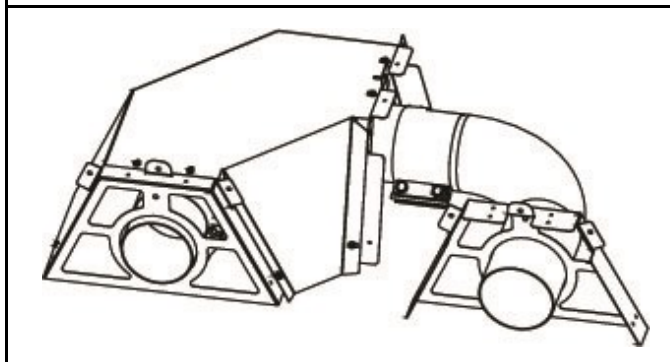

#9

Add the third plate hanger to the elbow kit – pay attention to the mouting position of the plate. Always with the cavity facing toward the ‘burner end’ of the system

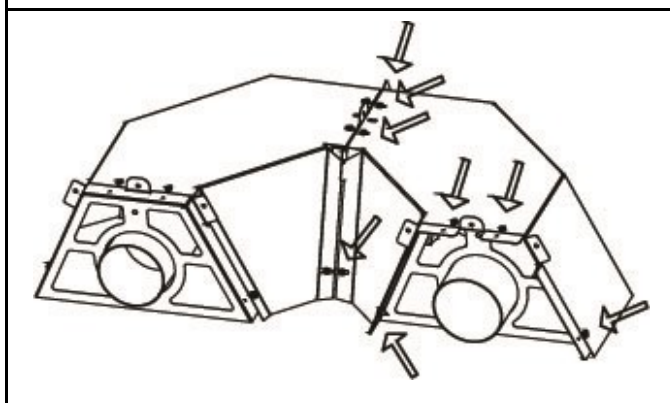

#10

Place the second reflector over the plate hangers. Secure the reflector with 8 screws to the plate hanger.

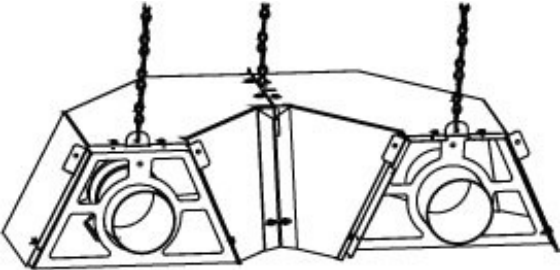
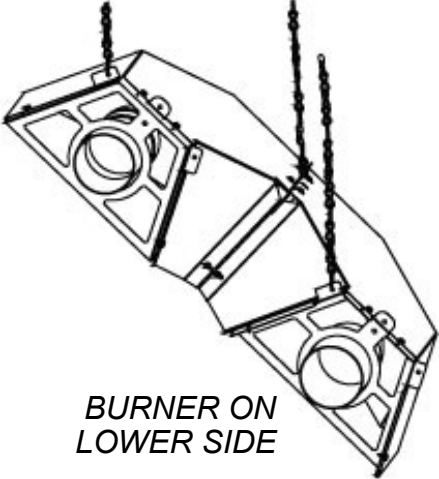
	<p>#11/A</p> <p>Suspend with 3 chains in horizontal position and continue installing the tubes and reflectors to complete the system.</p>
 <p>BURNER ON LOWER SIDE</p>	<p>#11/B</p> <p>When hanging a heater with a 180° elbow kit at 45° angle the <u>vent run tubes must be on top, with the burner on the lower side.</u></p>

JS-0504-JZ REFLECTOR ANGLE ADAPTER -JZ SERIES

1. A reflector angle adapter can be installed on either side or both sides of an elbow, depending upon site requirements for angling of reflectors
2. The angle adapter is installed on the 'flat' side of the webbed hanger (concave side of hanger must face inward towards the elbow)
3. Rotate the angle adapter around the tube to the desired angle of the reflector - established by the tube/reflector system hangers located before or after the elbow
4. Align one of the holes in the angle adapter with the hole at top center of the elbow/tube hanger
5. Bolt the angle adapter to the elbow/tube hanger through the aligned holes
6. The angle adapter will remain in place by resting on the tube
7. Attach reflector to the angle adapter with sheet metal screws



8. SUSPENDING THE SYSTEM - GENERAL



Inadequate or improper suspension of the tube heater can result in collapse of the system, property damage, and personal injury or death.

It is the installer's responsibility to ensure that the hardware and structural supports from which the heater is suspended are sound and of adequate strength to support the weight and expansion forces of the heater.

Consider that the heater will expand in length as much as 1/2 inch (12.5 mm) or more for every 10 ft (3 m) of system length – typically the greater the firing rate, the greater the expansion.

Refer to Sections 13 & 14

- 1) Survey the available structural supports, considering the system configuration and heat requirements of the area to establish the optimum heater location.
 - a) Locating a heater directly under joists or beams, or installing supplemental steel support rail or angle iron can substantially reduce labor and materials
- 2) Tube system hangers must be located: A) straight in line; B) at a common height (level); and C) 116" (295 cm) apart.- see *Figure 6 next page*.
 - a) NOTE: It is important that the tubes in the system are installed in alignment horizontally (level) and vertically (in line) – this will ensure system integrity
- 3) Hardware with a minimum 60 lb. (30 kg) work load must be used at each heater suspension point. A #8 Jack Chain or equivalent is typically used for suspending the heater.
 - a) Connect to the structure using typical hardware as illustrated in FIGURE 5 (below) or by other mechanically sound means
 - b) If rigid devices such as 3/8" threaded rods are used for suspension, swing joints or other means must be provided to allow for system expansion - approximately 1/2 inch to 1 inch for every 10 ft (1 cm to 2.5 cm for every 3 m) of system length.
- 4) Two types of hangers are provided to suspend the tube system – see FIGURES 6 & 7
 - a) Plate hangers support the tubes and reflectors at each end of the tube system
 - b) Webbed hangers support tubes and reflectors at each tube junction

FIGURE 5 TYPICAL MOUNTING HARDWARE



HOOK OR EYE
BOLT THROUGH
HOLE IN BEAM

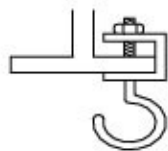

BEAM CLAMP
WITH HOOK OR
EYE

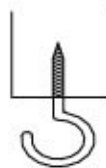

HOOK OR
EYE
SCREW



PIPE RING
OR CLEVIS
HANGER

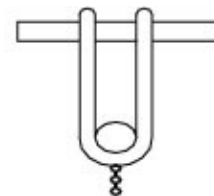

BAR-JOIST
CLAMP



NOTE: It is the installer's responsibility to ensure that mounting hardware and fastening to structure are of sufficient strength to support the system.

- 5) Please NOTE that each hanger has a 'flat' side and a 'cavity' side – FIGURE 6
- a) Starting at the burner end of the heater: all hangers except the last plate hanger are oriented with the cavity side of the hanger facing toward the burner end
 - b) The cavity side of only the vent end plate hanger faces the vent - FIGURE 6

Refer to Figures on next pages, then proceed to Section 9. Burner and Tube Installation

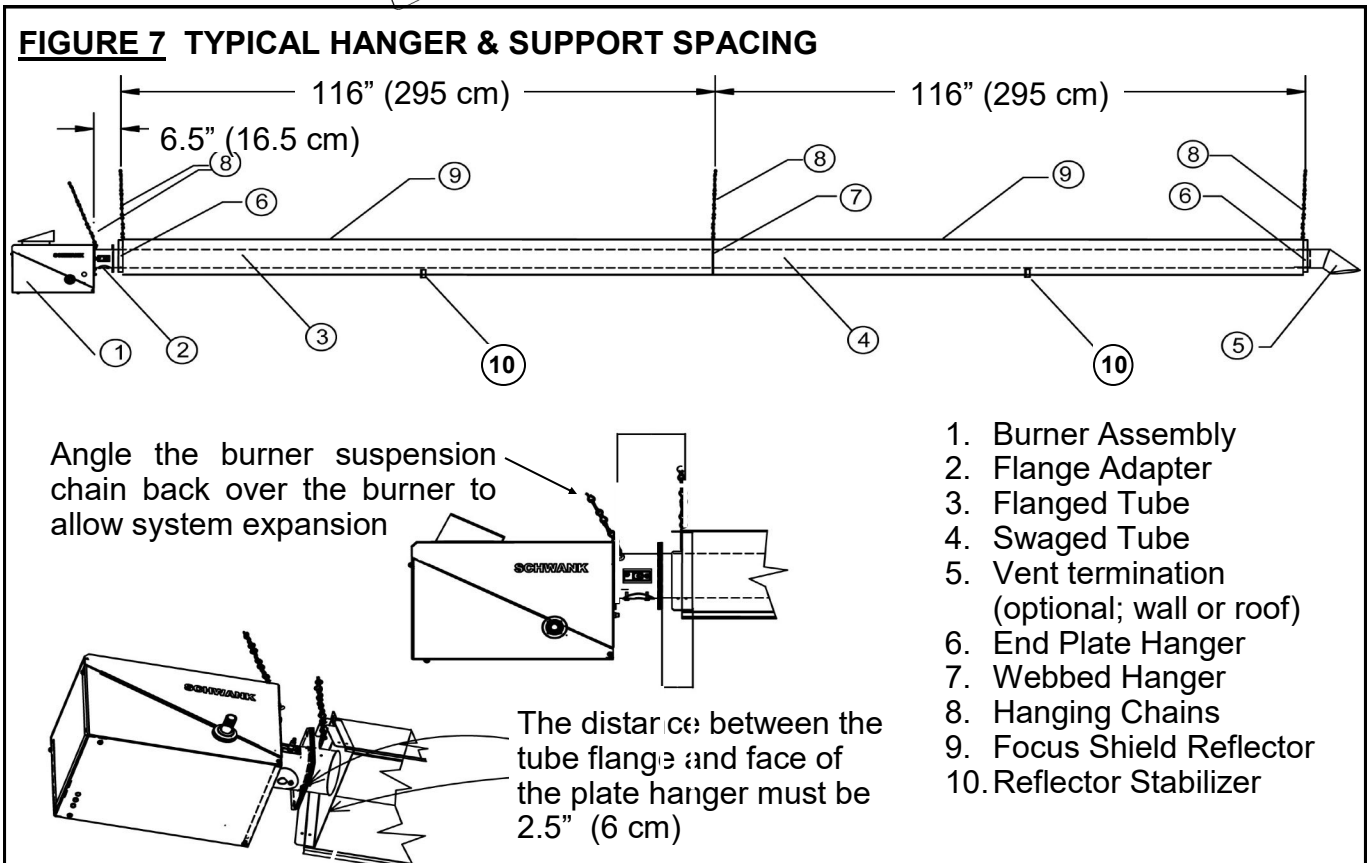
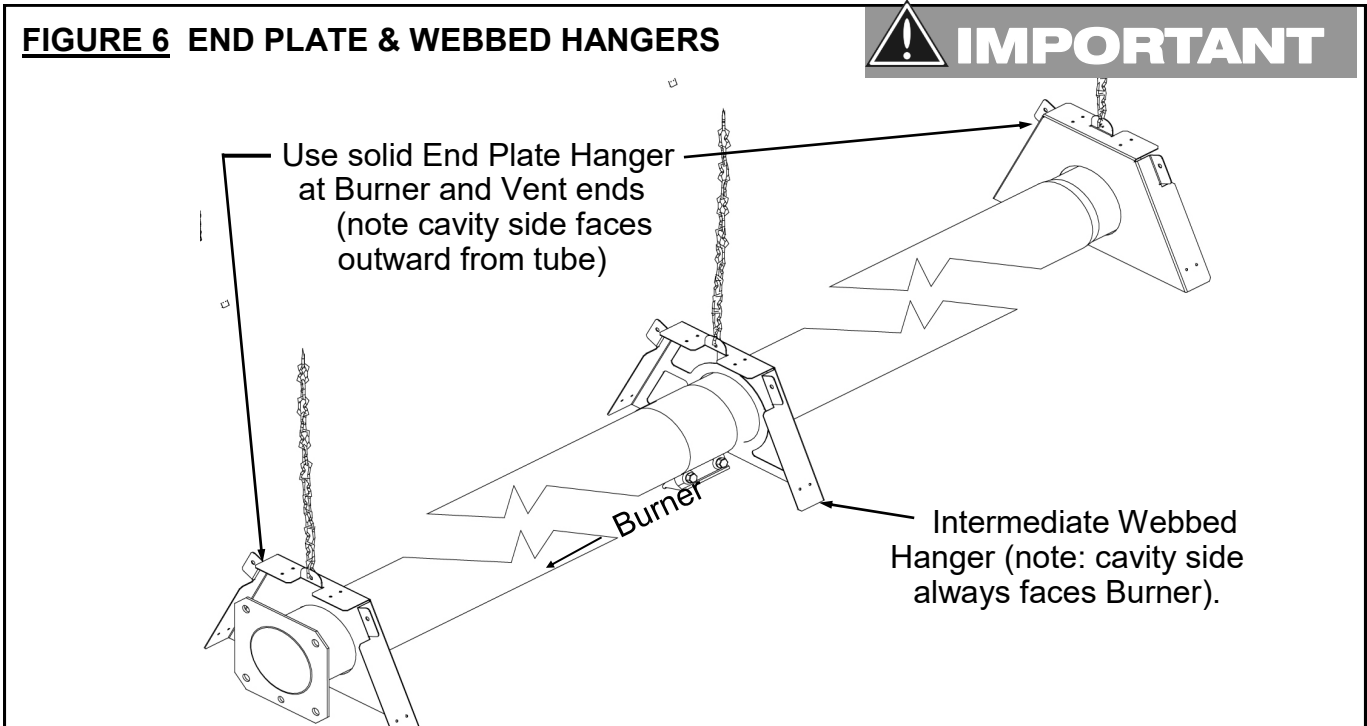
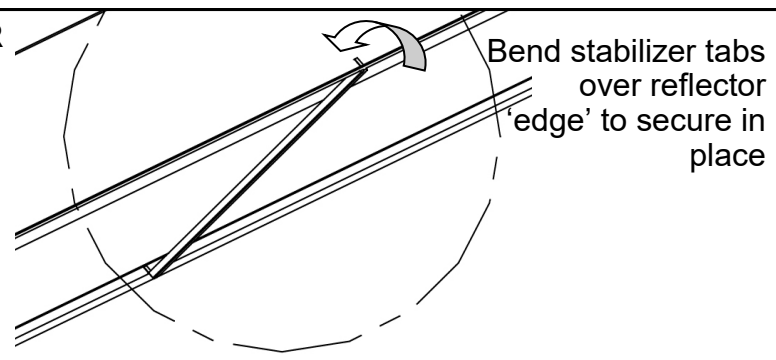
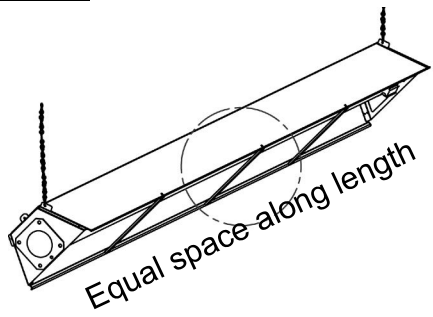
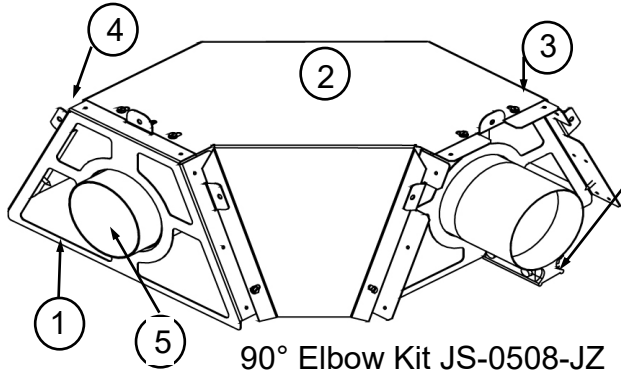

FIGURE 8 REFLECTOR STABILIZER



Bend stabilizer tabs over reflector 'edge' to secure in place

FIGURE 9 PLATE HANGER/ELBOW INSTALLATION see section 7



90° Elbow Kit JS-0508-JZ

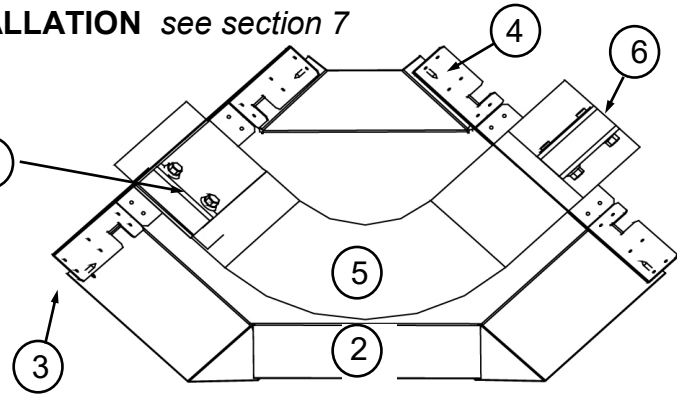

- 1. Webbed-Hanger
- 2. Reflectors
- 3. Webbed-Hanger Flange UNDER Reflector

- 4. Webbed Hanger Flange mounts UNDER and fastens the next Reflector
- 5. 90° Tube Elbow
- 6. Tube/Elbow Coupler

FIGURE 10 HANGER / REFLECTOR ORIENTATION HORIZONTAL TO 45°

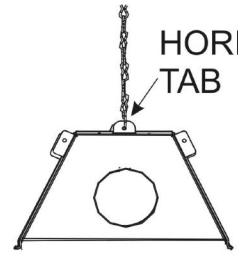

HORIZONTAL TAB

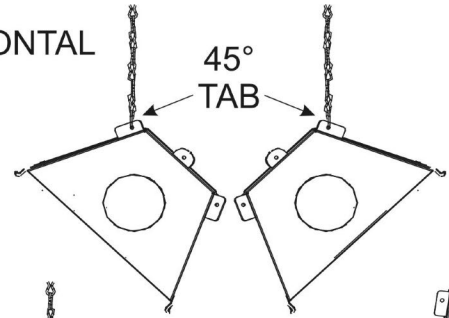

45° TAB

FOR ANGLE LESS THAN 45° USE CHAIN TO BOTH TABS

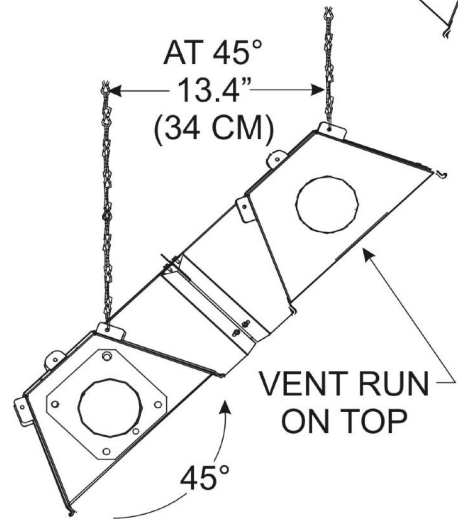

AT 45°
13.4"
(34 CM)

VENT RUN ON TOP

45°

COMBINE 2 x 90° ELBOWS TO CREATE 180° ELBOW

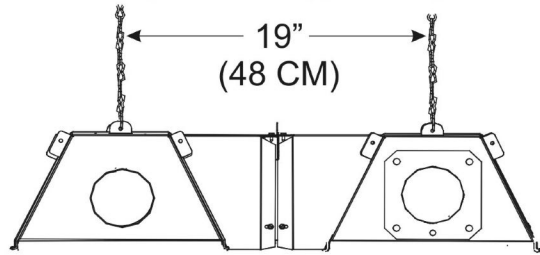

19"
(48 CM)

8-A. SEISMIC RESTRAINT - LATERAL AND LONGITUDINAL

In areas prone to earthquake, or as specified on a project, install lateral and longitudinal seismic restraints as indicated in Figure 11. If the heater location can be impacted by wind (aircraft hangars, etc) refer to High Wind Restraint section 8-B.

These restraint systems indicate suspension of and attachment to the heater. The attachment of suspension hardware to the structure will be as required by site structural conditions, installation codes, and/or local engineering design requirements. Other types or systems of restraint may be specified by local or national codes, or by project engineering design specifications.

Schwank / InfraSave offers optional items: #2 Lion Chain 115 lb work load x 200 ft roll (PN: JL-0800-XX); and Safety Snap Hooks (PN: JL-0800-SH = pkg 24; JL-0800-SH-B = pkg 100). All other required seismic mounting hardware is field supplied by the installer.

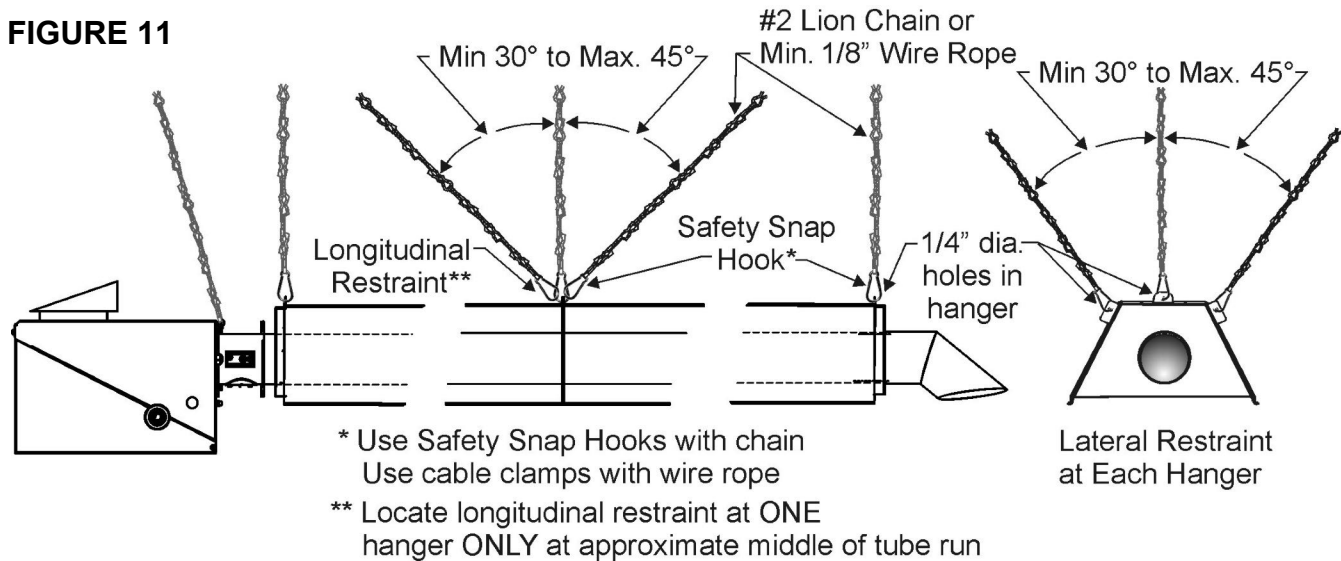

8-B. HIGH WIND RESTRAINT - LATERAL, LONGITUDINAL, AND VERTICAL

In areas with wind conditions (aircraft hangars, etc) in addition to lateral and longitudinal restraint the heater must be restrained from vertical movement. Suspend the heater using 3/8" threaded rod with 3" adjustment turnbuckle through a safety ring at each hanger location.

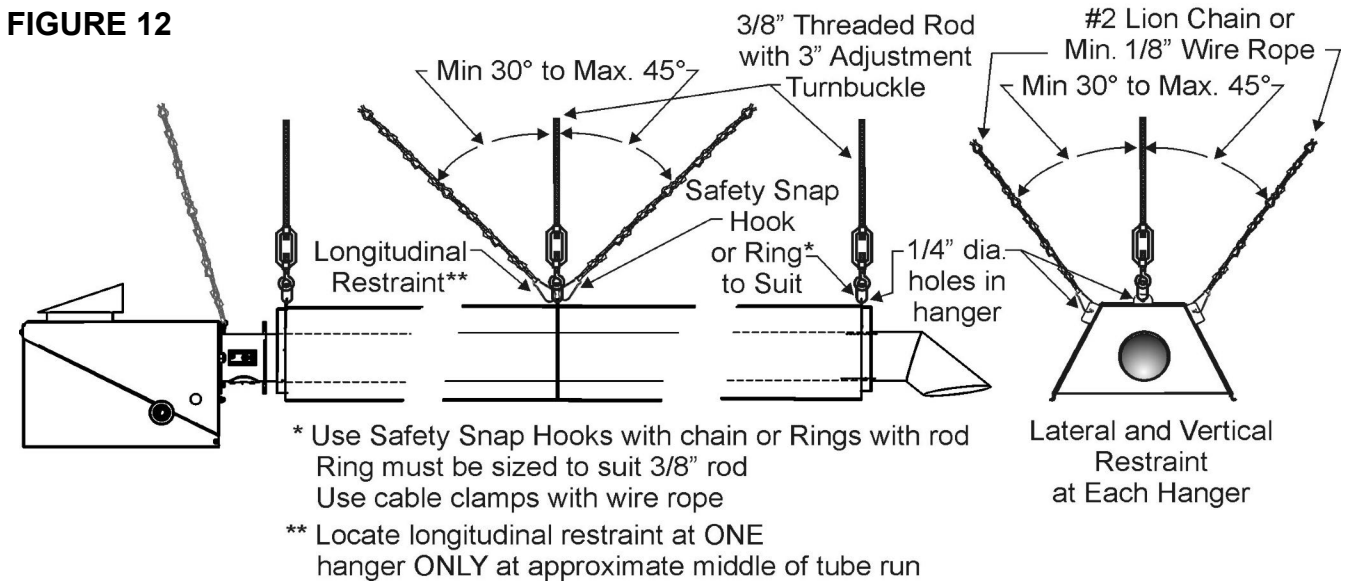

9. BURNER AND TUBE INSTALLATION

PRIOR TO PROCEEDING with the tube installation: **Read and understand Section 8 - "Suspending the System"**



SPECIAL NOTES:

1. **175,000 & 200,000**: Special Tube Coupling - Refer to Section 9.1, Fig 13
These firing rates have an unpainted stainless steel first tube with a flange (painted "white"), and an unpainted aluminized steel tube as the second tube; all subsequent tubes are painted steel
3. IF a 90° or 180° elbow is to be installed in the system, **refer NOW** to Section 7 and the Elbow Kit installation instructions supplied with the elbow kit
4. Turbulators are factory installed inside tube(s) that are clearly labeled with instruction as to where the tube(s) must be installed - **See pages 24 & 25 for specific information on turbulator length and location in the tube system**

ALL MODELS: INSTALL THE FIRST AND SECOND TUBES (FROM BURNER END) WITH THE WELDED SEAM (ALONG THE TUBE LENGTH) FACING DOWNWARD

- 1) All hangers must be:
 - a) Suspended at the same height = horizontal alignment of tubes
 - b) In a straight line = vertical alignment of tubes
 - c) Spaced 116" (295 cm) apart = correct spacing for reflector attachment
 - d) Orient hangers with the "cavity side" facing the burner end of the system (except the last plate hanger at the vent end = the cavity side faces the vent)
- 2) Insert the swaged end of the first tube (tube with flange) through the 4" (10 cm) hole in the first plate hanger (WELDED SEAM FACING DOWNWARD) – FIGURE 3
 - a) Ensure the 'cavity' side of the hanger faces the burner end of the system
 - b) Slide a Torctite tube coupler past the swage onto the tube
 - The final position of the coupler will be on the 'burner-end' side of the hanger
 - c) Guide the tube into the second hanger (webbed) – ensure the cavity side of the hanger faces the burner end of the system
 - d) Position the first plate hanger 2.5 inches (6.4 cm) from the tube flange – this will provide access to bolt the burner to the flange, and ensure correct spacing of consecutive system hangers
 - e) Check that the first tube is level
- 3) Install a focus shield reflector over the first tube - secure with sheet metal screws to the hanger at each end
- 4) Install three reflector stabilizers on the bottom of the reflector
 - a) Equally space stabilizers with one at the reflector center point
 - b) Firmly bend the end tabs on each stabilizer up over the 'trough' at each side of the reflector
- 5) Slide a Torctite tube coupler past the swage onto the next tube to be installed
- 6) Insert the swaged end of the tube into the next hanger to support its weight

continued ...



7) NOTE: **175,000 & 200,000 Btuh Systems:**

- Refer to Section 9.1, Fig 13

The second tube is unpainted aluminized steel for the 175,000 & 200,000

FOR ALL OTHER FIRING RATES: See FIG 11 below

Slide the female end of the second tube over the swage of the first tube

- Ensure that the swage on the first tube is fully inserted into the second tube
- Adjust the hanger so that it is located on the second tube, approximately 2" (5 cm) from the end of the tube – in this location the hanger supports both tubes.
- Slide the Torctite coupler into position across the center of the joint
- IMPORTANT: TORQUE THE COUPLER BOLTS TO 40 ft-lbs**
- The coupler is now in place on the 'burner-end' side of the hanger

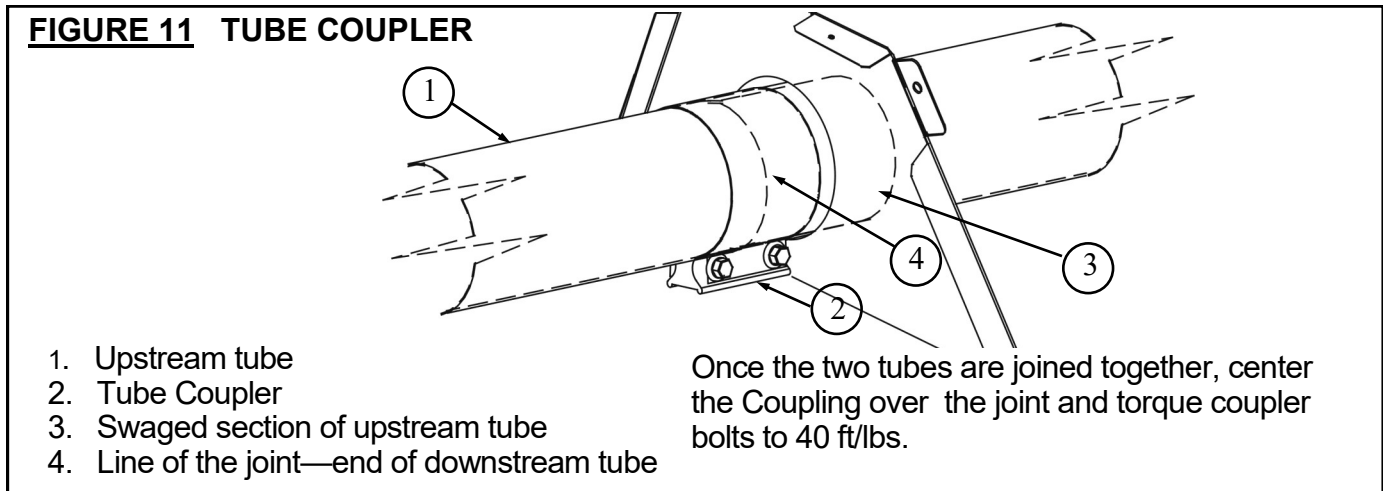

- CHECK THAT THE SECOND TUBE IS LEVEL, ALIGNED HORIZONTALLY AND VERTICALLY WITH THE FIRST TUBE – MAKE ADJUSTMENT AT SUSPENSION POINTS AS REQUIRED—THE WELDED SEAM ALONG TUBE LENGTH MUST FACE DOWN
- Install the reflector over the second tube and fasten to hanger at each end (See Section 10)
- Repeat these steps assembling one section of tube and reflector at a time until the system is complete
- ENSURE THAT THE SYSTEM IS LEVEL AND THAT ALL TUBES ARE ALIGNED HORIZONTALLY AND VERTICALLY – MAKE ADJUSTMENT AT SUSPENSION POINTS AS REQUIRED—WELDED SEAM OF 1st & 2nd TUBES MUST FACE DOWN
- Mount the Burner to the first tube flange using the four nuts and bolts provided (FIG 12)

(Continued on page 23)

- a) Insert two bolts through top holes in burner flange
 - b) Install gasket onto the two bolts to position it between the burner and tube flanges
 - c) Align burner and tube flanges and secure the two bolts with nuts
 - d) Install bottom bolts and nuts and snug to align the two flanges
 - e) **TIGHTEN THE BOLTS IN AN OPPOSITE CORNER SEQUENCE AND ENSURE THAT THE BURNER IS IN HORIZONTAL ALIGNMENT WITH THE TUBE**
- 13) The 'center of gravity' of the burner is slightly off-center that of the tube system.
In order to prevent rotation of the burner:
- Install support chain from the burner eye hook to a point approximately 6 to 10 inches (15 to 25 cm) back over the burner away from the first tube hanger to allow expansion of the system
 - **DO NOT** fasten chain from the burner eye hook to the first hanger suspension point
 - The support chain angled back over the burner will allow "straight back" movement of the burner when the system heats and expands.

FIGURE 12 BOLT BURNER TO FLANGED TUBE

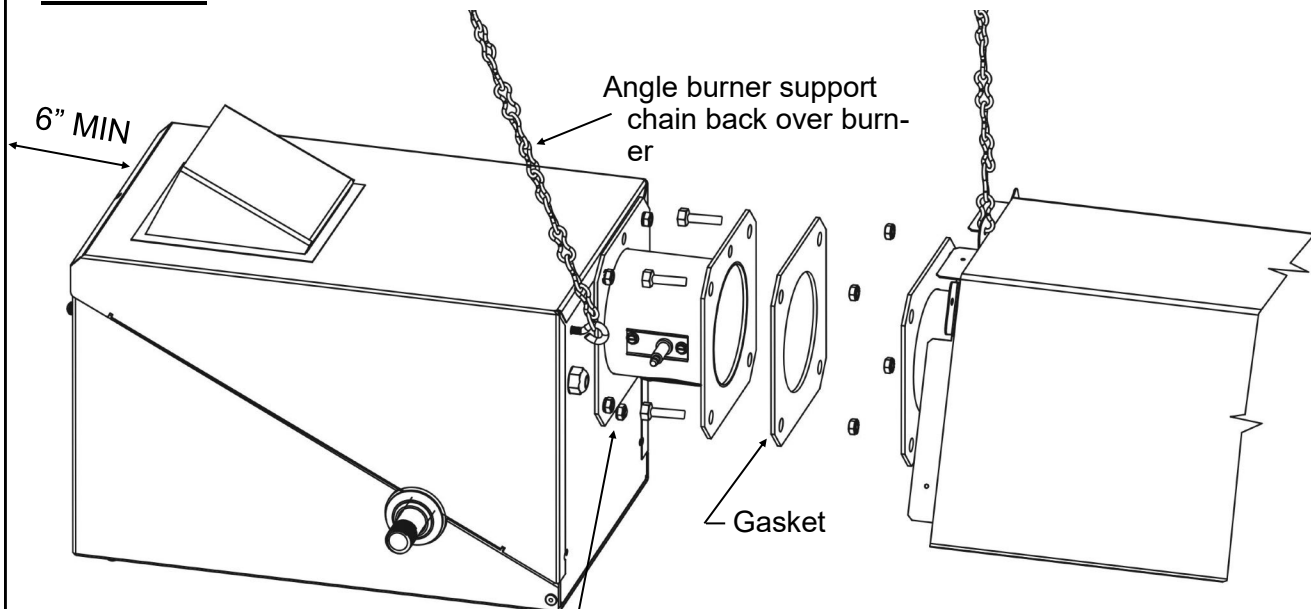

- Do not loosen or remove the fifth nut directly below the burner flange
- Secure suspension chain to eye hook in order to stabilize burner—angle chain back over burner 6 to 10 inches to allow for heater expansion.

SERVICE ACCESS: ALLOW A MINIMUM OF 6 INCHES (15 cm) FROM THE ACCESS END OF THE BURNER AND A MINIMUM OF 24 INCHES (60 cm) FROM EITHER SIDE OF THE BURNER TO A WALL OR ANY OBSTRUCTION THAT WOULD RESTRICT OR LIMIT ACCESS TO THE BURNER FOR SERVICE OR REPAIRS. (SEE SECTIONS 5 & 6 - PRE-INSTALLATION SURVEY AND MOUNTING CLEARANCES)

TURBULATOR LENGTH & LOCATION IN SYSTEM:



NOTE: Improper location of a turbulator can cause malfunction of the heater, property damage, and will void the heater warranty.

Tubes with turbulators are clearly labeled for easy identification. Models with asterisk refer to notes below the table.

See next page for an illustration of turbulator length and location.

TABLE 3: TURBULATOR LENGTH & LOCATION IN SYSTEM:

GAS TYPE	MODEL x Length (ft)	TURBULATOR LENGTH(S)
NG or Propane	45 x 20	39" + 96"
NG or Propane	60 x 20	39" + 96"
NG or Propane	60 x 30 ¹	96" ¹
NG or Propane	80 x 20	39" + 96"
NG or Propane	80 x 30 ¹	96" ¹
NG or Propane	80 x 40	24" + 109"
NG ONLY	100 x 20	Stamped S/S
NG or Propane	110 x 30	60" + 96"
NG or Propane	110 x 40	24" + 109"
NG or Propane	110 x 50	24" [3rd Tube]
NG ONLY	130 x 30	60" + 96"
NG or Propane	130 x 40	24" + 109"
NG or Propane	130 x 50	24" [3rd Tube]
NG or Propane	155 x 40	24" + 109"
NG or Propane	155 x 50	24" [3rd Tube]
NG or Propane	155 x 60	24" [3rd Tube]
NG or Propane	175 x 50/60 ²	40" + 72" ²
NG ONLY	175 x 70 ²	40" + 72" ²
NG ONLY	200 x 50	40" + 72"
NG or Propane	200 x 60/70 ³	40" + 72" ³

TURBULATOR FOOTNOTES:

- 60 / 80 x 30'**: Remove 5 ft section of turbulator from the aluminized steel tube (2nd tube in system); install tube with 96" turbulator at the vent end of the system
- 175 Propane x 60'**: Install tube with turbulators as **5th tube** in the system
175 NG x 60' & 70': Install tube with turbulators as **6th tube** in the system
- 200 x 60' & 70'**: Remove 40" piece of turbulator from the upstream end of tube with turbulator, and install the tube with turbulator as the **6th tube** in the system

TURBULATOR LENGTH & LOCATION IN SYSTEM: FIGURE 13

MODEL x LENGTH:

60; 80 x 20'

A/S TUBE SYSTEM ONLY

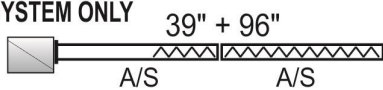

60; 80 x 30'

A/S & S/S TUBE SYSTEMS

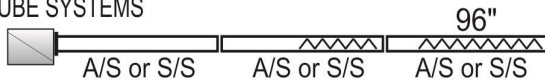

110; 130 x 30' (130 x 30' NG Only)

A/S TUBE SYSTEM ONLY

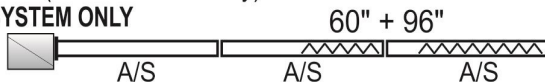

110; 130 x 40'

A/S & S/S TUBE SYSTEMS



155 x 40'

A/S TUBE SYSTEM ONLY



TUBE MATERIAL LEGEND:

A/S = ALUMINIZED STEEL (TW-xxxx-JZ)

S/S = STAINLESS STEEL (TW-xxxx-JZ2)

OPTIONAL STAINLESS STEEL TUBES / REFLECTOR SYSTEMS ARE AVAILABLE IN LONGEST MODEL LENGTHS ONLY

NOTE: MODELS BELOW: TUBE WITH TURBULATOR(S) IS PACKAGED IN THE 30 FT PRIMARY TUBE KIT

155 x 50'

A/S & S/S TUBE SYSTEMS

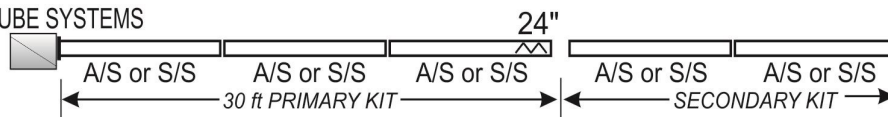

155 x 60'

A/S & S/S TUBE SYSTEMS

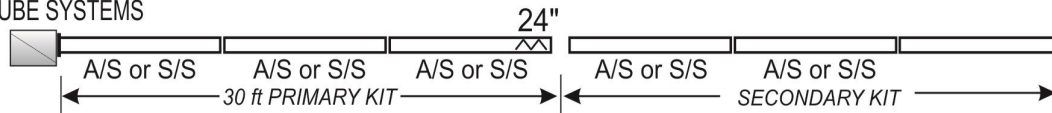

175; 200 x 50'

A/S TUBE SYSTEM ONLY

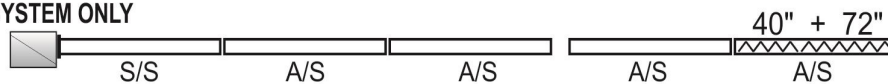

175 x 60'

A/S & S/S TUBE SYSTEMS



175 x 70'

A/S & S/S TUBE SYSTEMS

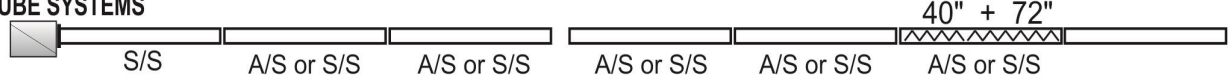

200 x 60'

A/S & S/S TUBE SYSTEMS



200 x 70'

A/S & S/S TUBE SYSTEMS

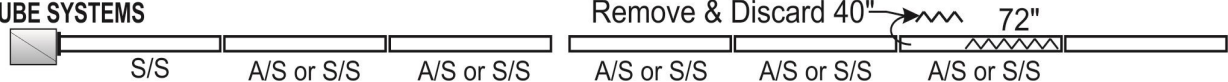



9.1 SPECIAL COUPLING: 175,000 & 200,000 Btuh

NOTE: The joint of 1ST & 2ND tubes of 175,000 & 200,000 heaters experience strong forces of expansion. Follow instructions below for special coupling of the tubes.

SPECIAL COUPLER INSTALLATION

1. Note the 2 holes opposite each other at the swaged end of the first tube (flanged)
2. Install the **first tube** with 2 holes (swaged end) at the 3 and 9 o'clock position, with the **welded seam located in the lower half of tube, facing downward**
3. Slide the loosened tube coupler on to the first tube, past the swage
4. The second tube has a $\frac{1}{4}$ " hole at the female end.
5. Slide second tube over swaged end of first tube to align the hole in the second tube with one of the holes in the first tube
6. Final alignment of the holes can be accomplished using a screw driver or other tool
7. **IMPORTANT:** Insert $\frac{1}{4}$ " rivet into the hole to secure the tube connection
8. Slide coupler into position – half onto each tube – covering the rivet head
9. Tighten coupler bolts to 40 ft-lb
10. Install reflectors

FIGURE 15 SPECIAL COUPLING:

- 175,000 & 200,000 Btuh

- Fasten Second Tube to First Tube -

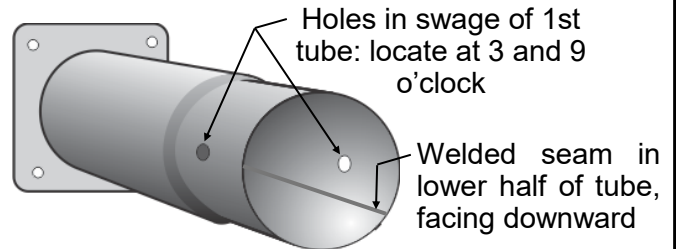

Steps 3 to 6

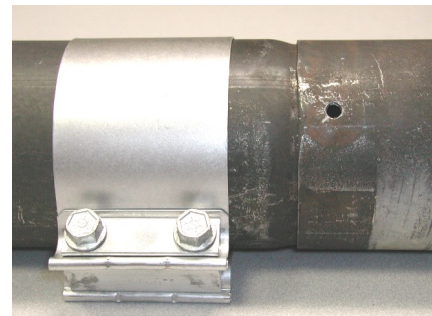

Step 7

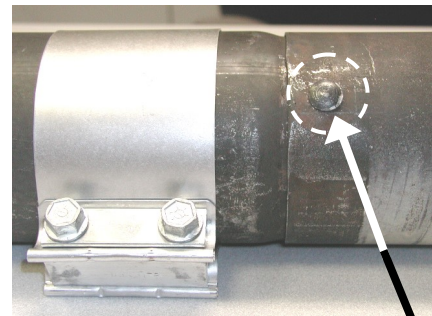

Step 8

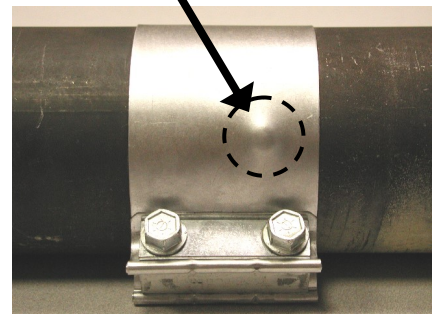

10. FOCUS SHIELD REFLECTOR INSTALLATION

The focus shield reflector system can be adjusted to either side up to 45° from horizontal. Note that for both horizontal and angle mounting, the tube must be level along its length. Improper mounting can result in overheating of controls and combustible materials. Use only non-combustible mounting hardware.

FIGURE 14 MOUNTING FOCUS SHIELD REFLECTOR TO HANGER

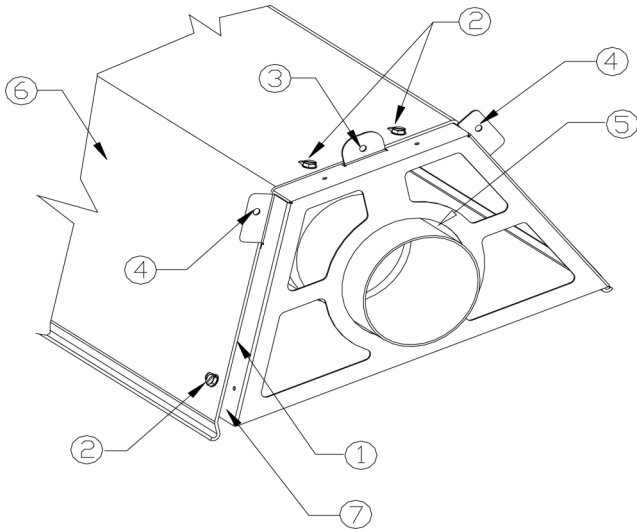

- 1 Webbed Hanger Flange under Reflector
 - 2 Screws to secure Reflector to Plate Hanger.
 - 3 Tab for horizontal suspension
 - 4 Tab for 45° suspension
- NOTE: For suspension between 1° and 44°, use both suspension points 3 and 4 (see Fig.15 below).
- 5 Opening for Tube
 - 6 Reflector
 - 7 The next Reflector will mount over and on-
to this side of the Webbed Hanger.

FIGURE 15 HANGER ARRANGEMENTS

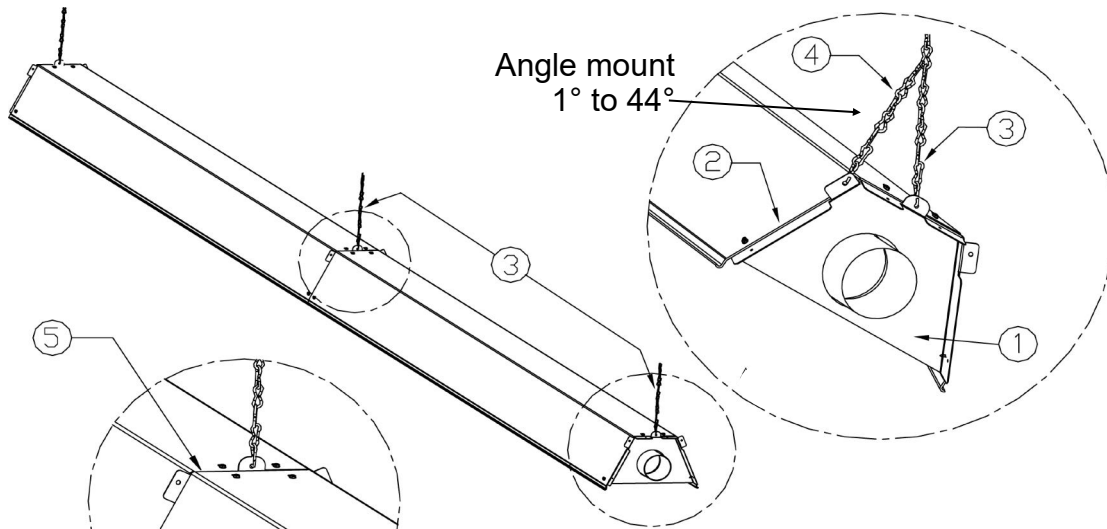

- ① End plate hanger at burner or vent end
- ② Plate hanger flange fitted UNDER reflector
- ③ System support chain
- ④ Auxiliary chain for angle adjustment 1° to 44°
(vary the top junction to adjust reflector angle)
- ⑤ Webbed hanger fitted UNDER reflectors

See more info next page

NOTE: Except for the vent end plate hanger, all hangers must be installed with the cavity side facing the burner end of the system - the cavity side of the vent end hanger must face

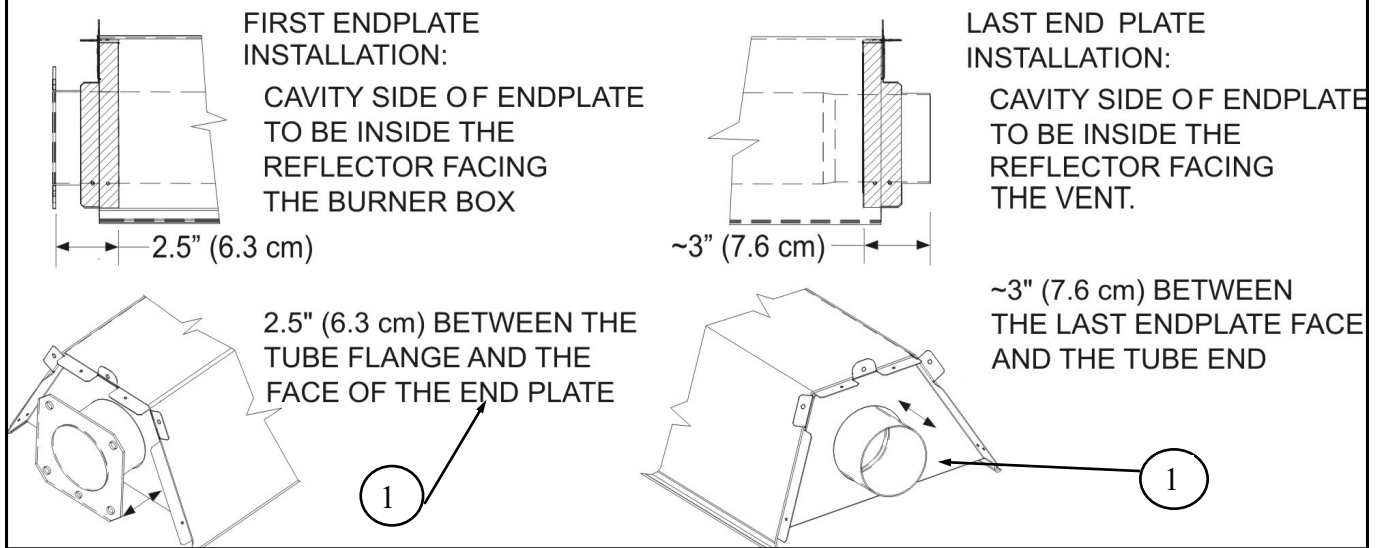
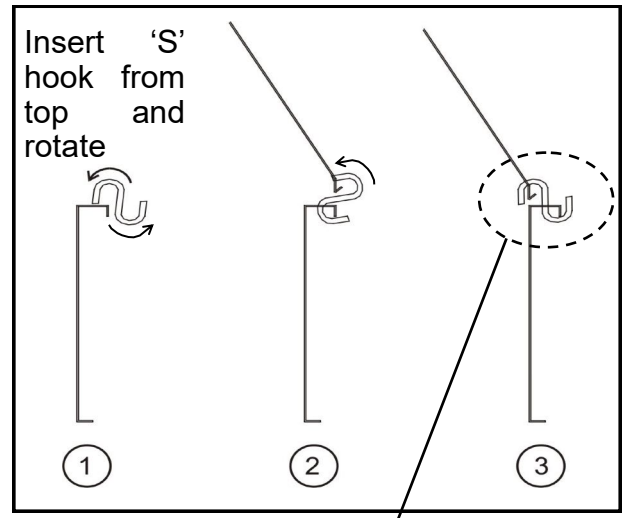
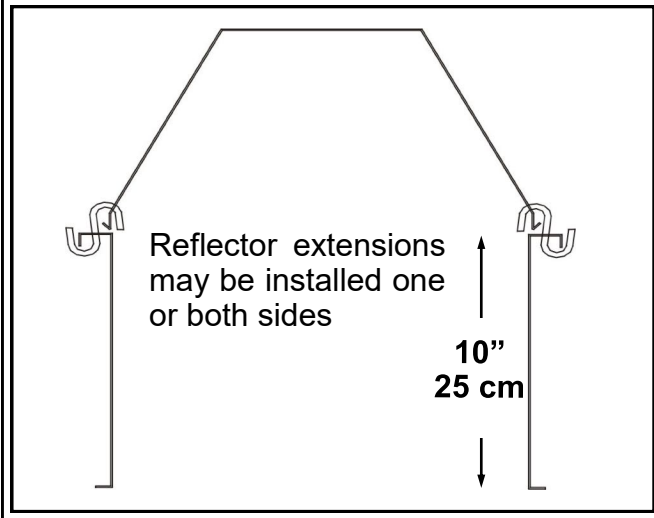
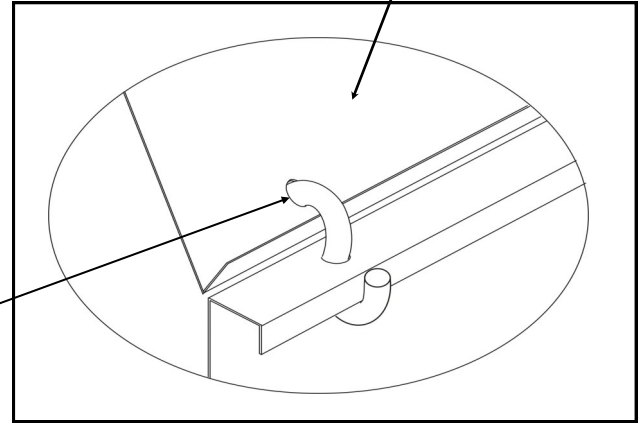

FIGURE 16 REFLECTOR EXTENSIONS

(OPTIONAL - IF REQUIRED)



1. Reflector extensions may be installed on one side or both sides of the reflector
2. Reflector extensions are 116" (295 cm) long
3. Holes (3) for "S" hooks are located 2.25" (5.7 cm) from each end and one at the center of the reflector extension
4. Drill 1/4" (7 mm) holes in the reflector 3/4" (2 cm) up from the bottom edge of the reflector to align with the 3 holes in the top of the reflector extension



5. Insert "S" hook down through hole in the top of the reflector extension
6. Rotate "S" hook approx. 90°, and insert into hole in reflector
7. Settle reflector extension into place

11. FLUE VENTING - RADIANT TUBE HEATER



IMPORTANT

Effective January 1, 2019: Changes to the ANSI/CSA standard that governs Radiant Tube Heaters specify the following appliance CATEGORIES and VENTING:

- **Vertical Vent Through Roof (Category I):** For vertical vent, this tube heater series operates with a negative static vent pressure and a vent temperature that does not result in excessive condensate in the vent and is defined as a Category I appliance. Refer to details below.
- **Horizontal Vent Through Wall (Category III):** For horizontal vent, this tube heater series operates with a positive static vent pressure and a vent temperature that does not result in excessive condensate in the vent and is considered a Category III appliance. Refer to details below.



WARNING

Inadequate venting of a heater may result in asphyxiation, carbon monoxide poisoning, injury or death. This heater may use a vent connection or indirect venting system to remove products of combustion from the space. Seal all vent connections with high temperature sealant. Venting must be in accordance with all local, state, provincial, and national codes (ANSI Z223.1/NFPA 54 in USA; B149.1 in Canada) and as indicated below in this manual.



THIS TUBE HEATER IS CERTIFIED FOR VENTING DIRECTLY TO THE OUTSIDE OR UNVENTED (INDIRECT VENTING) APPLICATIONS.

UNVENTED (INDIRECT MECHANICAL VENTING SYSTEM)

USA: Natural or mechanical means shall be provided to supply and exhaust at least 4ft³/min/1000Btuh (0.38m³/min/kW) input of installed heaters. Some local codes may require an electrical interlock to a dedicated exhaust fan. Exhaust must be located as high as practicable in the structure above the level of the heater(s). Consult your local code and ANSI Z223.1 latest edition for all venting requirements and practices.

Canada: It is required that the heater(s) be electrically interlocked to dedicated exhaust fan(s) by means of an Air Proving Switch. Exhaust fan(s) must be sized to create 300 cfm (8.5 cu m/min) exhaust for every 100,000 Btuh (30 kW) or any fraction thereof of total input of installed equipment. Exhaust must be located as high as practicable in the structure above the level of the heater(s). Sufficient supply air must be provided. Consult the latest edition of CSA.B149.1 Section 8 for venting system and air supply requirements.

VENTED TO THE OUTSIDE - GENERAL REQUIREMENTS

It is the responsibility of the installer to adhere to these instructions and all current local codes and/or ANSI Z223.1 (NFPA 54) or CSA.B149.1 latest editions for all venting requirements, and practices. All vent pipe will be certified to meet Category I (vertical vent) or Category III (horizontal vent) appliance requirements, depending on the vent configuration of a particular installation.

It is a normal condition that during heat-up and cool-down a tube heater will expand and contract. Allowances for heater expansion must be made in the venting and combustion air ducting. Improper installation can result in property damage, injury or death.

- When vented: The system must not be operated in a negative air condition unless combustion air is ducted from outside to the burner. If negative pressure is experienced or anticipated, the open port (barb) on each of the blocked flue and proving air switches must be Tee'd together and connected directly to outside air using a field supplied 1/4" plastic hose from the tee between the switches to outside of building.
- All approved vent pipe, connectors, and adapters are supplied locally by others according to

appliance Category, and specifications below.

- All venting must meet requirements of Local Codes or, in the absence of local codes, with the *National Fuel Gas Code*, ANSI Z223.1/NFPA 54; or the *Natural Gas and Propane Installation Code* CSA B149.1.
- A vent connector shall comply with local codes and be firmly attached to the flue collar by 3 x 1/2" sheet metal screws. Seal penetrations and connections with high temperature RTV silicone sealant.
- Install a minimum 12" [305 mm] straight vent connector before any Tee or 90° Elbow.
- The connection of vent components must be secured as specified in the installation instructions by the vent manufacturer.
- For vertical vent, any horizontal vent section will slope upwards away from the heater not less than 1/4 inch rise per foot of run.
- For horizontal vent, slope downward away from heater a maximum of 1/4 inch down per foot of run.
- When the vent pipe passes through a cold or unheated area where the ambient temperature is likely to produce condensation of the flue gases, the vent pipe will be insulated with a suitable material as certified and specified by the insulation manufacturer to withstand temperature up to 460°F (238°C).
- The vent system must **always** be adequately supported to prevent sagging.
- The vent configuration will allow for expansion and contraction in length of the tube heater.
- As an Option for vertical vent, two heaters may be vented through an approved common 4" x 4" x 6" Vent Tee (10 x 10 x 15 cm), supplied by the manufacturer, or by using approved components as indicated in local codes. Vent pipe from each heater is not required to be equidistant to the vent Tee, but must comply with local code requirements. A common thermostat or "ON/OFF" switch must control commonly vented heaters. **Common vent is not allowed for Category III horizontal vent application.**

COMBINED SYSTEM LENGTH: Tube Heater + Vent + Combustion Air Duct:

- **Refer to Table 4 next page, COMBINED SYSTEM LENGTH: TUBE + AIR DUCT + VENT.** Lengths in the table apply to either Vertical or Horizontal vent.
- **COMBINED SYSTEM LENGTH includes:** Tube Heater length + combustion air duct + vent + elbows. Each 90° elbow in the system has an equivalent length of 5 ft.
- A maximum of 2 elbows is allowed in any portion (duct, tube heater, vent) with the exception of up to three 90° elbows in a vertical vent run through the roof, for a total of maximum 6 (vertical vent: 7) 90° elbows in the combined system.
- Combustion air duct is not to exceed lengths in table below and may be 4" or 5" diameter for inputs less than 200,000 Btuh, but must be 5" diameter for inputs 200,000 Btuh and greater.
 - 5" diameter duct requires a reducer to 4" diameter at the connection to blower inlet.
- Exceeding the allowable lengths in the table below can create combustion and/or condensation issues and will void Certification and the heater warranty.
- Do not exceed the **Maximum Combined System Length** regardless of the allowed maximum length of individual vent or combustion air duct.

TABLE 4: COMBINED SYSTEM LENGTH

Installations up to 4500 ft - Higher altitudes refer to Section 27

INSTALLATIONS UP TO 4500 FEET (Higher altitudes refer to Section 27)						
Input (Btuh)	Do Not Exceed Maximum Combined System Length		Max. Air Duct Length (by Duct Diameter)		Max. Vent Length Individual: 4"Ø OR Combined: 6"Ø	Example
	4" Air Duct	5" Air Duct	4" Ø	5" Ø		
45,000 & 60,000	60 ft	80 ft	20 ft	40 ft	20 ft	150,000 Btuh Heater: Tube Heater Length 50 ft 1 x 90° elbow (vent) 5 ft Straight vent 20 ft 1 x 90° elbow (duct) 5 ft Air Duct: 4" Ø 17 ft Combined Length 97 ft Max. Allowed 100 ft
80,000	70 ft	90 ft	20 ft	40 ft	20 ft	Additional 20' for 5" Ø Air Duct
110,000 to 150,000	100 ft	120 ft	30 ft	50 ft	30 ft	
175,000 & 200,000	120 ft	140 ft	30 ft	50 ft	40 ft	

HEATER EXPANSION AND VENT CONFIGURATION

A radiant tube heater will expand and contract as it heats and cools. Configuration of the vent must allow for heater expansion.

VERTICAL VENT: Orientation of the vent at 90° to heater will allow for heater expansion and contraction.

HORIZONTAL VENT: (See FIG. 17)

- Wall Thimble or flashing at wall that allows movement of the vent through the opening. Do not seal the vent to the thimble or flashing with caulking.

OR

- Offset vent with two x 90° elbows. Install minimum 12 inch [305 mm] length of straight vent between elbows. Vent can be sealed with caulking at non-combustible wall.
- Other means of slip fit installation of the vent are acceptable providing there is adequate allowance for free expansion and contraction of the system, and free flow of vent gases.

FIGURE 17: ALLOW FOR HEATER EXPANSION - HORIZONTAL VENT - TOP VIEW

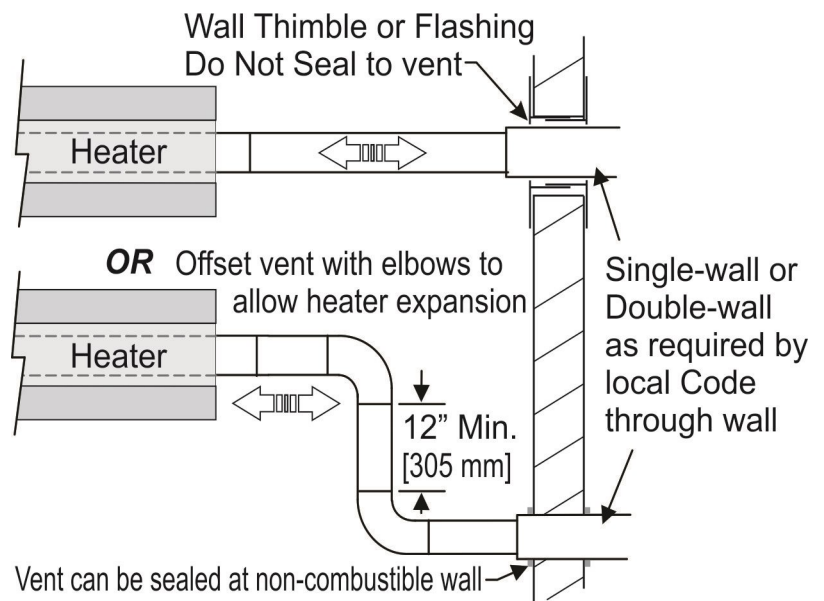

COMMON VENTING

For vertical vent only, two heaters can be commonly vented using 4"x 6"x 4" Vent Tee JA- 0514-XX. Both heaters must be operated using one common thermostat. Common vent is 6 inch [150 mm] diameter.

Category III (horizontal vent) heaters cannot be common vented.

VERTICAL VENT THROUGH THE ROOF (CATEGORY I):

It is the sole responsibility of the installer to adhere to all current local codes and/or ANSI Z223.1 / CSA.B149.1 latest editions for all venting requirements, and practices. Also adhere to instructions below, and the instructions of the vent manufacturer. Use vent materials certified for Category I.

All models of this series heater are certified Category I for vertical venting. See FIG. 18.

- The vertical Type B-vent must extend at least 5 feet [1524 mm] above the flue collar of the highest connected heater.
- USA: Horizontal run of single wall vent or vent connector ("H" in FIG. 18) must not exceed 75% of the vertical height of the vent. If it does, then the vent system must be for Category III.
- Single wall vent connector material must be corrosion-resistant galvanized steel with a minimum thickness specified in local code.
- A vent connector must be secured to the flue collar using quantity 3 x #8 x 1/2" sheet metal screws. Seal penetrations and connections with high temperature RTV silicone sealant.
- A horizontal vent connector shall be installed and supported without any dips or sags and shall slope upward toward the vent or chimney at least 1/4 in./ft (20 mm/m).
- Use a certified termination cap as supplied by the manufacturer of the vent.
- When vent and combustion air are taken through the roof, the exhaust vent should always terminate higher than the combustion air intake, to prevent recycling the products of combustion back into the heater.
- The vent must extend at least 2 feet [610 mm] above the highest point where it passes through a roof. The vent must also extend at least two feet higher than any portion of a building within a horizontal distance of 10 feet [3 m].
- Keep vent connector runs as short as possible with a minimum number of elbows. Refer to the current edition of ANSI Z223.1 (NFPA 54) or CSA-B149 installation codes for maximum length of horizontal vent and vent connector.
- Total length of the vent connector and vent pipe cannot exceed the values in Table 4 above.
- A single-wall vent connector shall not be insulated.
- For single-wall vent clearance to combustibles is 6" [152mm] except where a listed clearance thimble is used. Clearance to combustible material for Type B-Vent or factory-built vent per the vent manufacturer's instructions.
- When an existing Category I heater is removed or replaced, the original venting system may no longer be sized to properly vent the attached appliances. Improperly sized venting systems can result in vent gas leakage or condensation.

FIGURE 18: VERTICAL VENT

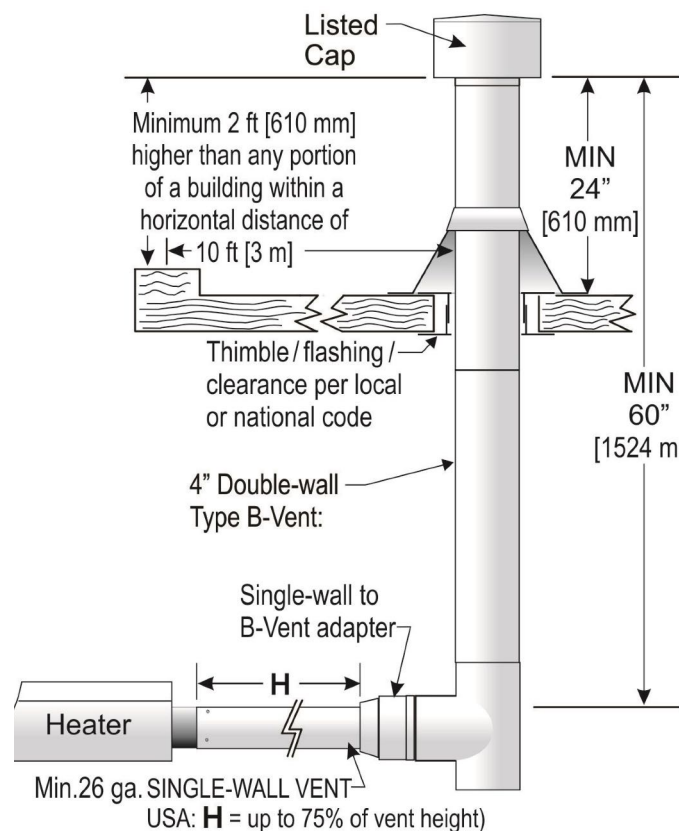

HORIZONTAL VENT THROUGH THE SIDEWALL (CATEGORY III):

All vent must be installed in accordance with local codes or, in the absence of local codes, with the *National Fuel Gas Code* in the USA, ANSI Z223.1/NFPA 54; or the *Natural Gas and Propane Installation Code* CSA B149.1 in Canada.

When installed with a horizontal vent through a sidewall, this heater is a Category III appliance, and the vent system must be approved for Category III application in accordance with UL-1738 or ULC-S636. Do not use PVC or plastic vent pipe.

- Use either a certified Category III venting system, or single wall vent pipe with all of the joints and seams sealed with a heat-resistant pliable sealant.
- The vent system must be installed in accordance with these instructions, and the instructions of the vent manufacturer.
- A single wall vent system may use a single continuous 36 inch section of double wall vent pipe to pass through an exterior wall:
 - Single wall galvanized vent pipe (C-Vent): Minimum 26 ga.
 - Single Wall to Double Wall Adapter: Duravent 4PVP-AD Adapter or equivalent.
 - 36 Inch Double wall vent through outside wall: Duravent PelletVent Pro (PVP) or equivalent:
- Single-wall vent: Seal all joints and seams in the pipe, and the adapter with high temperature Red RTV sealant for temperatures up to 600°F [315°C]. The sealant must remain pliable when in use. Follow the instructions of the vent manufacturer for sealing vent pipe connections.
- All vent sections and vent connector must be secured using quantity 3 x #8 x 1/2" sheet metal screws. Seal penetrations and connections with high temperature RTV silicone sealant.
- Any horizontal portion of the flue vent system must slope downwards away from the heater a minimum of 1/4" per foot run [63 mm/ 300 mm] toward the vent terminal.
- Horizontally vented Category III heaters must be individually vented and cannot use a common vent.
- Use approved 4" [102 mm] (JA-0528-XX) horizontal wall vent terminal or an approved high-wind termination cap.
- Installation of the vent must prevent blockage by snow and protect building materials from degradation by flue gases.
- Install termination cap a minimum of 18 inches (45 cm) from the outside wall to the inside edge of terminal opening to alleviate back pressure caused by turbulent wind conditions (See Fig. 8). This also ensures flue gases are directed away from the structure to protect building materials from degradation by the exhausted flue gases.
- At most two 90° elbows can be installed in a horizontal vent.
- All seams and joints must be checked for gas tightness after installation. With the heater in operation, conduct a leak test on all vent connections, joints, and seams using a soap solution.
- A horizontal flue vent will not terminate less than 1 ft [30 cm] above grade level, unless its location is adjacent to a public walkway, then it must not terminate less than 7 ft [2.1m] above the walkway.
- Clearance above vent terminal under a combustible overhang or soffit:
 - As indicated in FIG. 6 for approved terminations: 4" [100 mm] JA-0528-XX.
 - For other approved terminations: Will terminate 3 ft [915 mm] or more below a combustible soffit or overhang.
- A horizontal vent termination must be a minimum of 6 feet [1830 mm] from an inside corner formed by two exterior walls.
- All vent pipe, adapters, thimbles, supplied locally by others.

Specific requirements for horizontal vent in the USA and Canada are on the next page.

USA specific horizontal vent requirements:

- The vent terminal of an appliance with an input up to 50,000 Btu/hr (14.7kW) shall be installed with a 9 inch [230mm] vent termination clearance from any air opening into a building, and an appliance with an input over 50,000 Btu/hr (14.7kW) shall have at least a 12 inch [305 mm] vent termination clearance. The bottom of the vent terminal and the air intake shall be located at least 12 inches [305 mm] above grade.
- A horizontal vent will not terminate:
 - Less than 3 ft [915 mm] above a mechanical air inlet located within 10 ft [3 m].
 - Less than 4 ft [1219 mm] below, 4 ft [1219 mm] horizontally from, and 1 ft [102 mm] above any window or door that opens, or gravity air inlet to a building.
 - Less than 4 ft [1219 mm] horizontal clearance from gas and electric meters, regulators and relief equipment.

CANADA specific horizontal vent requirements:

- A horizontal vent will not terminate:
 - Within 6 ft [1830 mm] of a mechanical air supply inlet to any building.
 - Above a gas utility meter and regulator assembly within 3 ft [915 mm] horizontally of the vertical centerline of the regulator vent outlet to a maximum vertical distance of 15 ft [4.5 m].
 - Within 3 ft [915 mm] of any gas pressure regulator vent outlet.
 - Within the following distances of a window or door that can be opened in any building, of any non-mechanical air-supply inlet to any building, or of the combustion air inlet of any other appliance:
 - 12 inches [305 mm] for inputs up to and including 100,000 Btuh (30 kW).
 - 3 ft [915 mm] for inputs exceeding 100,000 Btuh (30 kW).

FIGURE 19: HORIZONTAL VENT THROUGH WALL

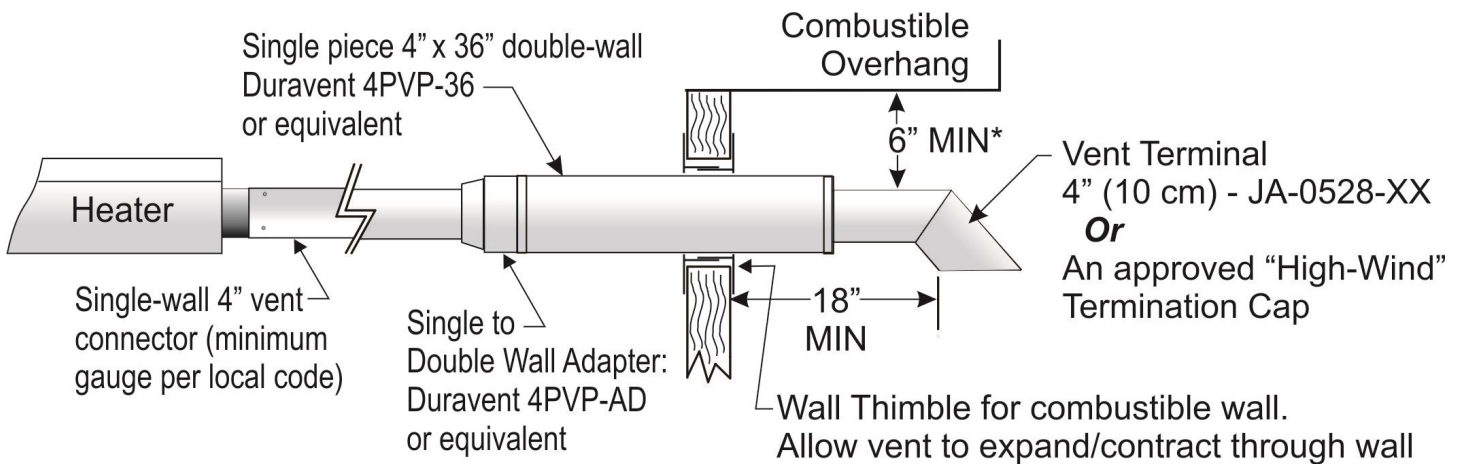

* 6" Clearance above optional Vent Terminal JA-0528-XX - 4" (10 cm). Use of alternate High-Wind terminal may require higher clearance. Refer to Vent Cap manufacturer's instructions.

12. COMBUSTION AIR DUCTING

Do not install filters on the combustion air intake.

Ensure adequate clearance around the air intake to allow sufficient combustion air supply to the heater.

An opening is located on the top surface of the burner housing for combustion air. Ensure adequate clearance around this opening to allow sufficient combustion air supply to the heater. Combustion air duct must be constructed of noncombustible material.

When a tube heater is vented to the outside and operated in a negative air condition or air-borne dust or contaminants are present as in woodworking and welding shops, air for combustion must be ducted from outside the negative or contaminated area to the 4 inch (10 cm) diameter intake flange supplied on the blower. Maximum system, vent and duct length is listed above.

- The total system length and individual flue vent or the combustion air duct is not to exceed the lengths listed above
- Total combined system length is reduced by five feet for every 90° elbow installed in the vent or duct *and* in the tube system (see above for allowable total lengths)
- Exceeding the allowable lengths may create condensation or soot conditions and will void CSA Design Certification and product warranty

The air intake will not be located less than:

- Three feet above grade
- Twelve inches from flue vent terminal of any heater with input up to 100,000 Btu/hr
- Three feet from flue vent terminal of any heater over 100,000 Btu/hr

This heater has an optional fresh air intake duct hood for wall (JS-0532-VC) or roof cap (JS-0530-XX) to bring combustion air to the heater from outside. Ensure adequate clearance around the air intake to allow sufficient combustion air supply to the heater. If drawing fresh air from outside, it is recommended that any single wall pipe containing cold air be insulated to prevent or reduce condensation on the pipe.

CAUTION: If a tube system is indirectly vented, ensure that warm moist outside air is not drawn through the air duct and tube system during summer months - condensation can occur inside the system and cause damage.

Do not use flexible dryer hose or any 'soft wall' tubing for air inlet duct, the corrugated sides of this tubing restrict air flow. A good quality industry approved insulated flex is allowed.



CAUTION: In locations where chlorinated Hydrocarbons are in use, such as Trichloroethylene or Chloroethylene Nu it is essential that combustion air be brought in from a non-contaminated area. Burning the fumes from these gases will create Hydrochloric acid fumes, which are detrimental to humans, equipment and buildings. Typical sources of other contaminants are paint removers, paints, refrigerants, solvents, adhesives, degreasers, lubricants, pesticides, etc.



The heater manufacturer cannot anticipate all types and chemical composition of possible contaminants at project sites. Confer with project site safety, health and engineering staff and/or local authorities having jurisdiction such as the Fire Marshall and Department of Labor for possible contaminants and any conflict with the installation of hot surface heating equipment.

13. GAS SUPPLY - HEATER EXPANSION - FLEXIBLE GAS CONNECTION

The gas supply must be installed to the heater using:

- **USA:** an approved Stainless Steel Flexible Gas Connector certified for use on an infrared radiant tube heater (ANSI Z21.24 CSA 6.10);
- **CANADA:** an approved Type 1 Hose Gas Connector (CAN/CGA 8.1).
- The heater must be isolated from the gas supply piping system by closing its individual manual shut off valve (field supplied) during any pressure testing of the gas supply piping system.

CAUTION: Compensation for normal gas supply pipe expansion, and radiant tube heater expansion must be provided. All piping must conform to local codes— Refer to Heater Expansion & Flexible Gas Connection—Sections 14 next two pages Provide a 1/8 in (3.2 mm) NPT plugged tapping, accessible for test gauge connection, immediately upstream of the gas supply connection to the heater.



DO NOT use pressure greater than 1/2 psig to pressure check the heater.



TEST FOR LEAKS: All gas piping and connections must be tested for leaks after the installation is completed.

Apply soap suds solution to all connections and joints and if bubbles appear, leaks have been detected and must be corrected. **DO NOT USE A MATCH OR OPEN FLAME OF ANY KIND TO TEST FOR LEAKS. NEVER OPERATE THE HEATER WITH LEAKING CONNECTIONS.**



The supply system should be checked first with heater turned “OFF” followed by another check with heater turned “ON”.

IMPORTANT: Minimum supply line pressure at the inlet to the heater regulator must not be lower than 5.0 inches of water column pressure for natural gas. The supply gas pressure must be checked with all heaters in operation.



Installation of a gas line (trap) “drip leg” is required at the inlet connection tee following the pipe drop to the heater. Failure to provide a “drip leg” could result in condensation and foreign matter passing into the gas valve. Failure to install a “drip leg” in the gas line can cause property damage, injury or death and will void the heater warranty.



TABLE 4

GAS TYPE	<u>LINE PRESSURE</u> INCHES WATER COLUMN		<u>MANIFOLD PRESSURE</u> (tap at gas valve outlet) INCHES WATER COLUMN
	MINIMUM	MAXIMUM	
Natural Gas	5.0	14.0	3.5

NOTE: Access to the manifold pressure test port is on the top of the valve. A 3/16" Allen Wrench is necessary to check this. When checking or setting the manifold pressure, a **water manometer** should be used. Gauges which measure in ounces per square inch or pounds per square inch are not accurate enough to properly measure or set the pressure.

 **WARNING**



THIS HEATER WILL EXPAND IN LENGTH AS IT HEATS UP. It is a normal condition that during heat-up and cool-down a tube heater will expand and contract. Allowances for heater expansion must be made in the gas connection, venting and combustion air ducting. Improper installation, alteration, or adjustment can result in property damage, injury or death. **See also Section 13**



The Btuh input and the tube length determine the overall expansion that occurs. A typical infrared tube installation will expand toward both the Burner and the vent end.



To allow heater expansion the gas supply must be installed using:

In the USA: a stainless steel Flexible Gas Connector certified for use on an infrared radiant tube heater (ANSI Z21.24 CSA 6.10);

in CANADA: a Type 1 Hose Connector (CAN/CGA 8.1). Also the flue vent, and combustion air intake (if used) must be installed in such a manner that the normal expansion of the heater will be accommodated.



IMPORTANT: See next page: orientation of connection between heater and gas supply.

TABLE 5

Input Rating Btuh	Tube Length Feet	Approx. Expansion in Length	USA: Mandatory Flexible Gas Connector ID x Length - Part #	CANADA: Mandatory Type '1' Gas Hose Size - Part #
45,000	10	1"	1/2" x 24" - JL-0771-XX	1/2" x 36" - JL-0771-RC
45,000	20	1 1/4"	1/2" x 24" - JL-0771-XX	1/2" x 36" - JL-0771-RC
60,000	20 / 30	1 1/2"	1/2" x 24" - JL-0771-XX	1/2" x 36" - JL-0771-RC
80,000	20 / 30 / 40	1 3/4"	1/2" x 24" - JL-0771-XX	1/2" x 36" - JL-0771-RC
110,000	30 / 40 / 50	2"	1/2" x 24" - JL-0771-XX	1/2" x 36" - JL-0771-RC
125,000 NG	30 / 40 / 50	2"	1/2" x 24" - JL-0771-XX	1/2" x 36" - JL-0771-RC
125,000 Propane	40 / 50	2"	1/2" x 24" - JL-0771-XX	1/2" x 36" - JL-0771-RC
150,000	40 / 50 / 60	2 1/2"	3/4" x 36" - JL-0771-YY	3/4" x 36" - JL-0771-RB
175,000	50 / 60 / 70	2 3/4"	3/4" x 36" - JL-0771-YY	3/4" x 36" - JL-0771-RB
200,000	50	2 3/4"	3/4" x 36" - JL-0771-YY	3/4" x 36" - JL-0771-RB
200,000	60 / 70	3 1/4"	3/4" x 36" - JL-0771-YY	3/4" x 36" - JL-0771-RB

FIGURE 20 ORIENTATION OF FLEXIBLE GAS CONNECTOR



The flexible gas connector **MUST** be installed in the orientation shown below as required by national installation codes and by the certification standard of this heater. This orientation protects the flexible gas connector from damage due to movement during heater expansion.

It is the responsibility of the installer to ensure correct installation of the flexible gas supply.

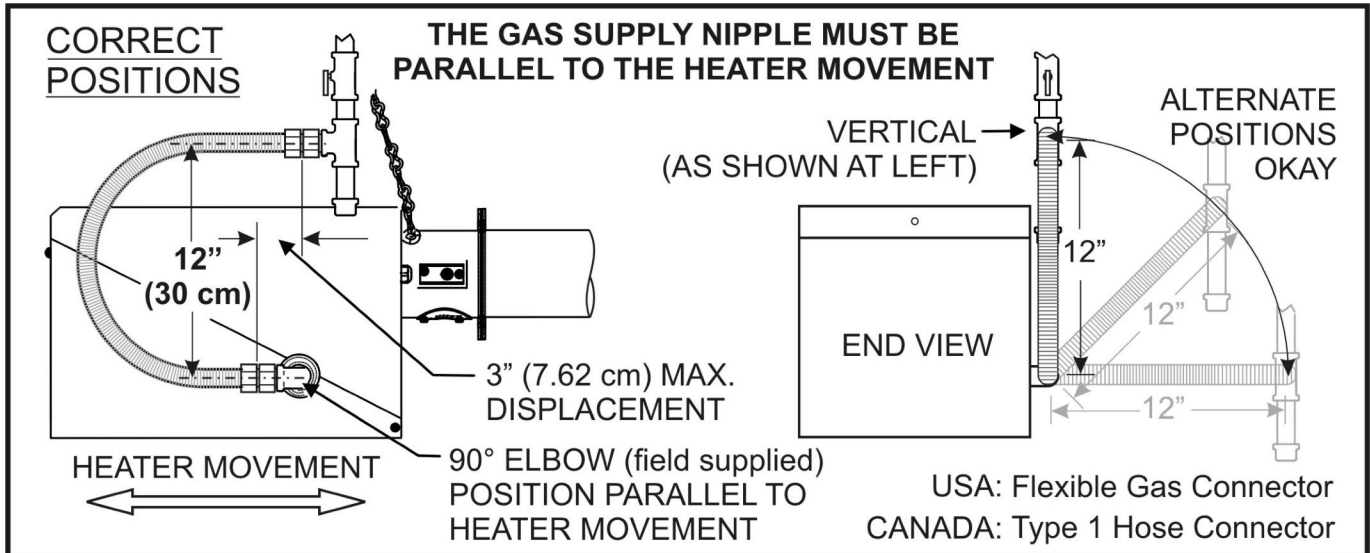

WARNING: CONNECTOR MUST BE INSTALLED IN "C" CONFIGURATION. USE ONLY THE CONNECTOR OF PROPER LENGTH AND NOMINAL ID THAT IS FURNISHED WITH THIS HEATER - SEE TABLE PREVIOUS PAGE.

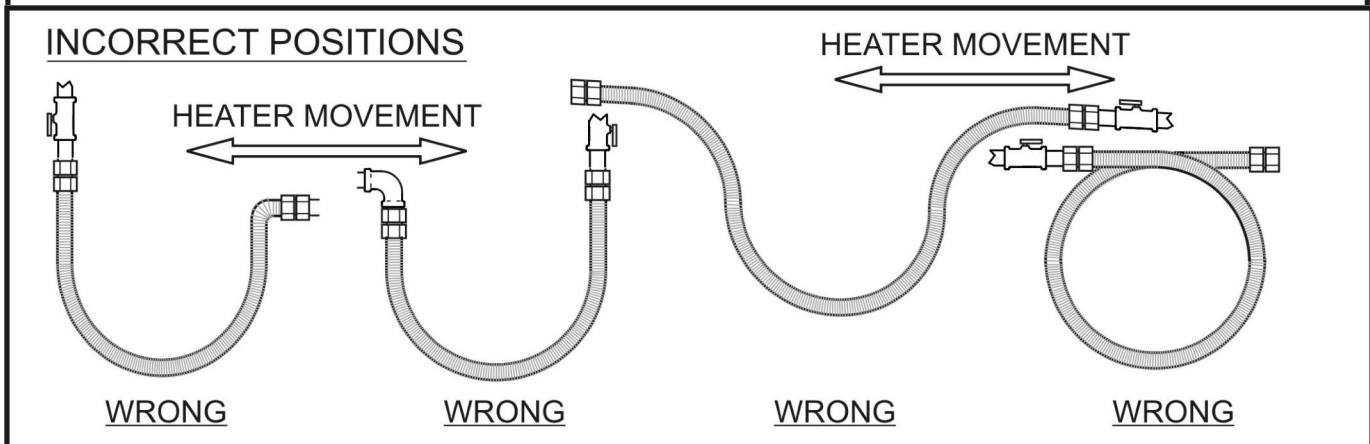

The flue vent, and combustion air duct (if installed) must also be configured in such a manner that the normal expansion of the heater will be accommodated. **See Section 11.**

14. ELECTRICAL AND THERMOSTAT WIRING (WIRING DIAGRAMS PAGE 35 & 36)



The heater must be electrically grounded in accordance with the National Electrical Code. ANSI / NFPA 70 or current Canadian Electrical code CSA C22.1.

Appliance and control wiring must be in accordance with all applicable local codes. The total load of all heaters must be considered in determining the required contact rating of the controlling thermostat or switch. Each tube heater requires 120V, 60 HZ electrical power sized for 145VA. The heater includes a 24V/120V relay switch and can be controlled by a 24V Thermostat, a TruTemp Thermostat, a line voltage Thermostat or by an "ON/OFF" switch. Maximum power flow for internal 24V burner components is 21VA.

A maximum night set-back of 9°F (5°C) is recommended for optimum economy and comfort. To maintain satisfactory comfort levels do not turn off the heating system over night/weekends.

15. HIGH ALTITUDE INSTALLATIONS - *also refer to chart in Section 28*

When installed above the altitude stipulated below for the USA or Canada, the input must be de-rated by 4% for each 1000 ft above the altitude listed . **If your local utility supplies gas with a de-rated heat content, no orifice change is required in the heater** . If the gas supply is not de-rated, the orifice must be changed according to the chart in Section 27. Check with your local utility regarding the gas supply and the de-rating of this appliance. Maintain gas supply pressures indicated in Table 4, page 32.

USA: The factory installed orifice for this appliance is approved for altitudes zero to 2000 feet above sea level. When installed above 2000 feet, **refer to Section 28**.

Canada: The factory installed orifice for this appliance is approved for altitudes zero to 4500 feet above sea level. When installed above 4500 feet, **refer to Section 28**.

16. LIGHTING INSTRUCTIONS

Refer to the lighting instructions label on the outside of the burner housing. If the unit locks out on safety, main power to the unit must be manually interrupted for a 30 second reset period before the heater can be restarted.

NOTE: *On initial installation, the unit may lock out on safety owing to the length of time required to bleed air from the gas piping system.*

17. RECOMMENDED MAINTENANCE

Improper adjustment, alteration, service or maintenance can cause property damage, injury or death. This heater must be installed and serviced only by a trained gas service technician.



1. Inspect the entire heater system, venting, and gas supply connections at least annually prior to the heating season. Replace worn parts and repair deficiencies.
2. Check the inlet air opening and the blower periodically, cleaning off any lint or foreign matter. It is important that the flow of combustion and ventilation air must not be obstructed.
3. Lubricate Blower motor, by adding several drops of oil to oil ports located on the left hand side of the motor.

THE TUBE HEATER BURNER IS COMPLETELY FACTORY ASSEMBLED AND TESTED. ANY ALTERATION VOIDS THE CSA CERTIFICATION AND MANUFACTURER'S WARRANTY. FOR ADDITIONAL INFORMATION, CONTACT YOUR LOCAL DISTRIBUTOR OR MANUFACTURER.

**18. WIRING DIAGRAM: 24V OR 120 VOLT THERMOSTAT OPERATION
SINGLE HEATER PER THERMOSTAT**

(Multiple Heaters per Thermostat—next page)

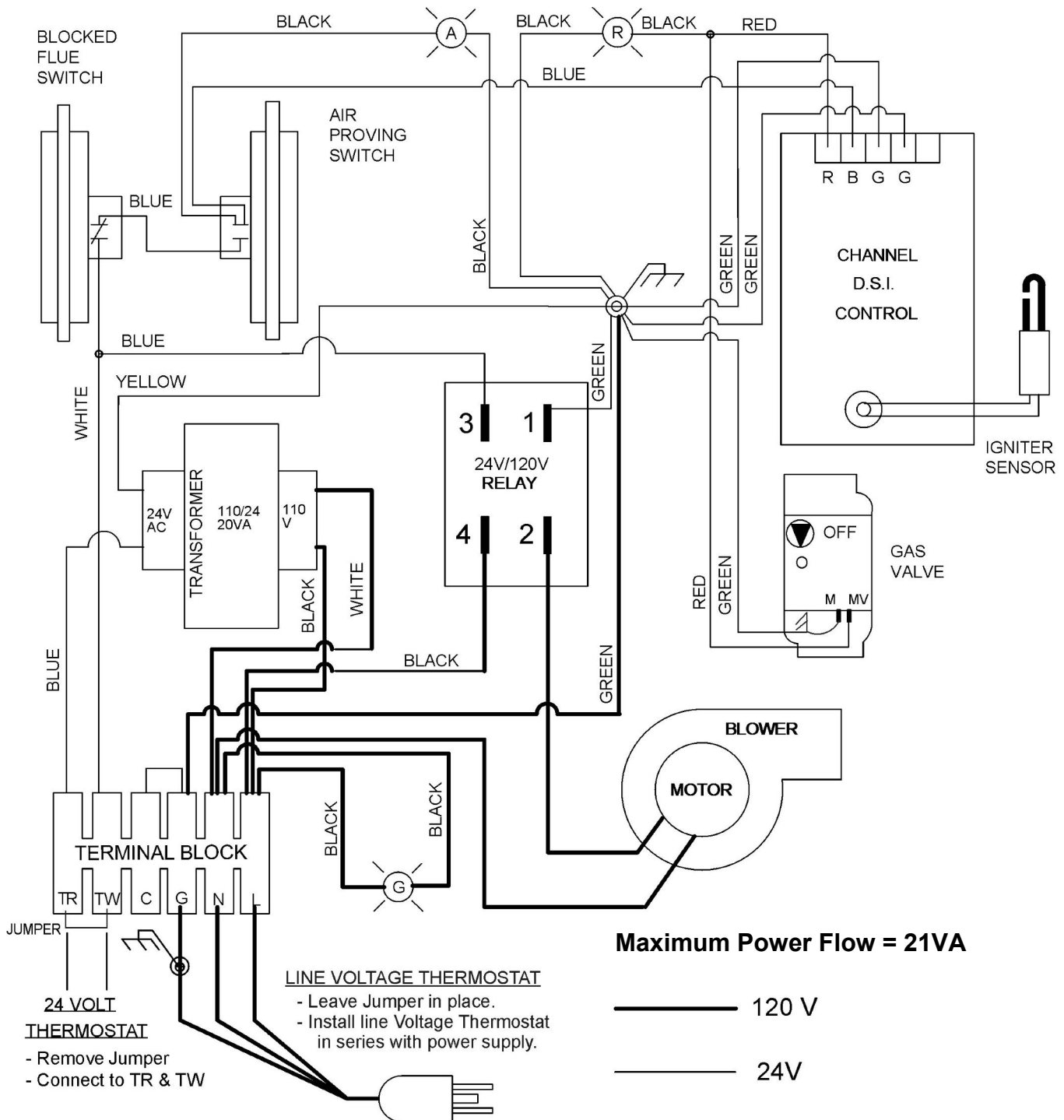

Each tube heater requires 120V, 60 HZ electrical power sized for 145VA. The heater includes a 24V/120V relay switch. Maximum power flow for internal 24V burner components is 21VA.

The heater must be electrically grounded in accordance with the National Electrical Code. AN-SI / NFPA 70 or current Canadian Electrical code CSA C22.1.

A maximum night set-back of 9°F (5°C) is recommended for optimum economy and comfort. To maintain satisfactory comfort levels do not turn off the heating system over night/weekends.

19. MULTIPLE TUBE HEATERS per 24VAC THERMOSTAT

TruTemp or 3-Wire 24Vac Thermostat At Burner #1:

- 3-Wire connection required
- Remove Jumper (TR to TW)
- TruTemp 'R' to TR
- TruTemp 'W' to TW
- TruTemp 'C' to G (ground)

BURNER #2
P/N: JS-0568-CC

R W C

RELAY SWITCH
P/N: JS-0568-CC

— Factory Wiring
- - - Field Wiring

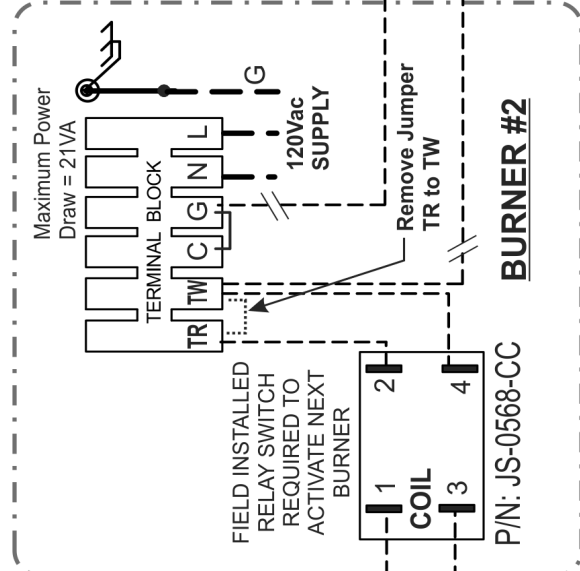
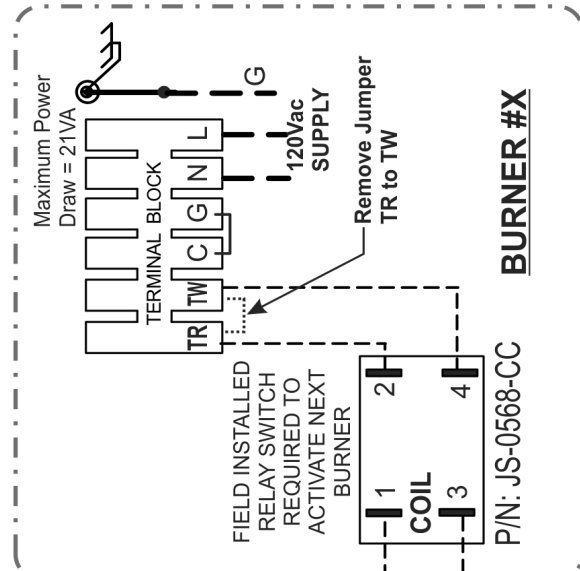
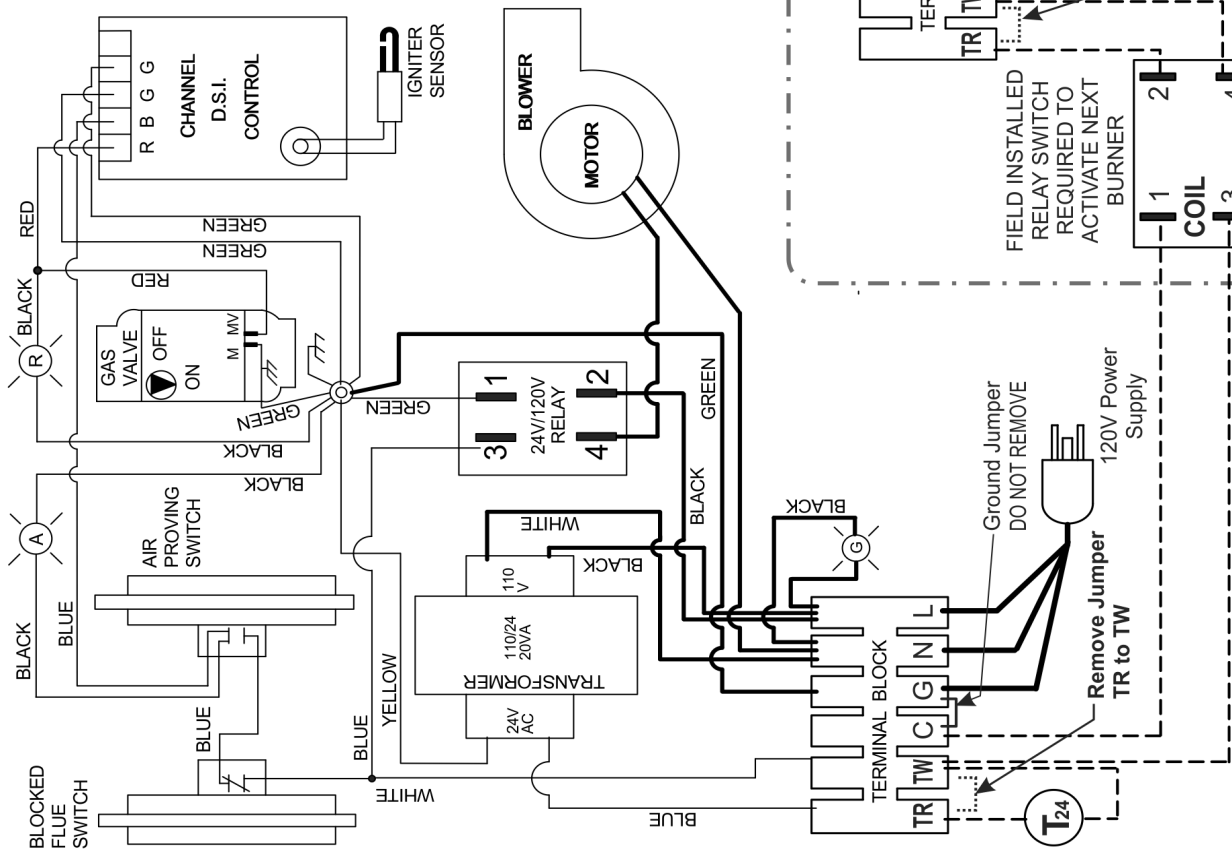

BURNER #1 2-Wire 24V Thermostat
(see 3-Wire above) →

20 SEQUENCE OF OPERATION GASLITER 50N DIRECT SPARK IGNITION (DSI)

The Gasliter 50N is a three trial ignition control module with a 30 minute soft lockout/reset. It is powered by a 24v transformer that is activated when the thermostat calls for heat. On every call for heat the Gasliter 50N will delay start-up to provide a 30 second system pre-purge. When the Gasliter 50N is activated by a thermostat or call for heat an internal transformer provides power to the electronic generator circuit for Spark Ignition and the retrial/safety lockout timing begins. At the same time, the Gasliter 50N opens the gas control valve allowing gas to flow to the main Burner.

The Gasliter 50N Control Module performs the following basic functions:

- Provides a 30 second system pre-purge
- Supplies power to the electronic pulse-generator circuit for the Spark Igniter (30,000 volts open circuit).
- Allows up to three 20 second Trials For Ignition (TFI) before a 'soft' system safety lockout of 30 minutes occurs.
- Three time TFI and soft 30 minute lockout repeat
- Senses the Burner flame for safe lighting
- Shuts off the spark after the Burner is lit.

Burner with direct spark ignition, sequence is as follows :

- 1a. **Line Voltage Thermostat:** Upon a call for heat by the line voltage Thermostat or "ON/OFF" switch, the Blower and the 120/24 volt Transformer are powered simultaneously with 115 volts. *continue to 2.*
- 1b. **24 Volt Thermostat:** The 120 volt supply to heater will power the 120v/24v Transformer and the 120V side of the Blower switching relay simultaneously. A call for heat by the 24 volt Thermostat energizes the 24 volt control circuit and the 24v/120 volt relay powering the Blower.
2. The 24 volt control circuit powers the DSI control in series through the normally open Air Pressure Switch (APS) and the normally closed Blocked Flue Switch (BFS).
3. The Blower creates a positive pressure and closes a normally open contact inside the Air Proving Switch (APS).
4. Provided there is no blockage in the system (tube and vent), the Blocked Flue Switch remains in a normally closed position.
5. 24 volts supplied to the DSI control initiates the 30 second pre-purge cycle.
6. After completing the 30 second pre-purge cycle the DSI control generates high voltage to the Spark Igniter, and 24 volts to energize the Gas Valve.
7. The Burner will light and establish a steady flame.
8. Once the flame sensor determines there is a steady flame established, with a minimum flame signal of 1.5 μ A the spark igniter is then de-energized.
9. In the event ignition does not occur, the DSI control will retry the ignition sequence up to an additional two trials. If ignition does not occur after the third ignition trial, the system will enter a 30 minute 'soft' lock-out. This will reset the ignition module and the operating sequence will restart at step #1 after the 30 minute lock-out period.
10. If there is a loss of flame during the run mode, the unit will energize the spark within 0.8 seconds and perform a T.F.I., without the gas valve being closed first, this is called Spark Restoration. If a flame is not established during Spark Restoration the unit will repeat the process in step number 9 (above).

21. TROUBLESHOOTING GUIDE



WARNING

Improper adjustment, alteration, service or maintenance can cause property damage, injury or death. This heater must be installed and serviced only by a trained gas service technician

SEQUENCE OF EVENTS

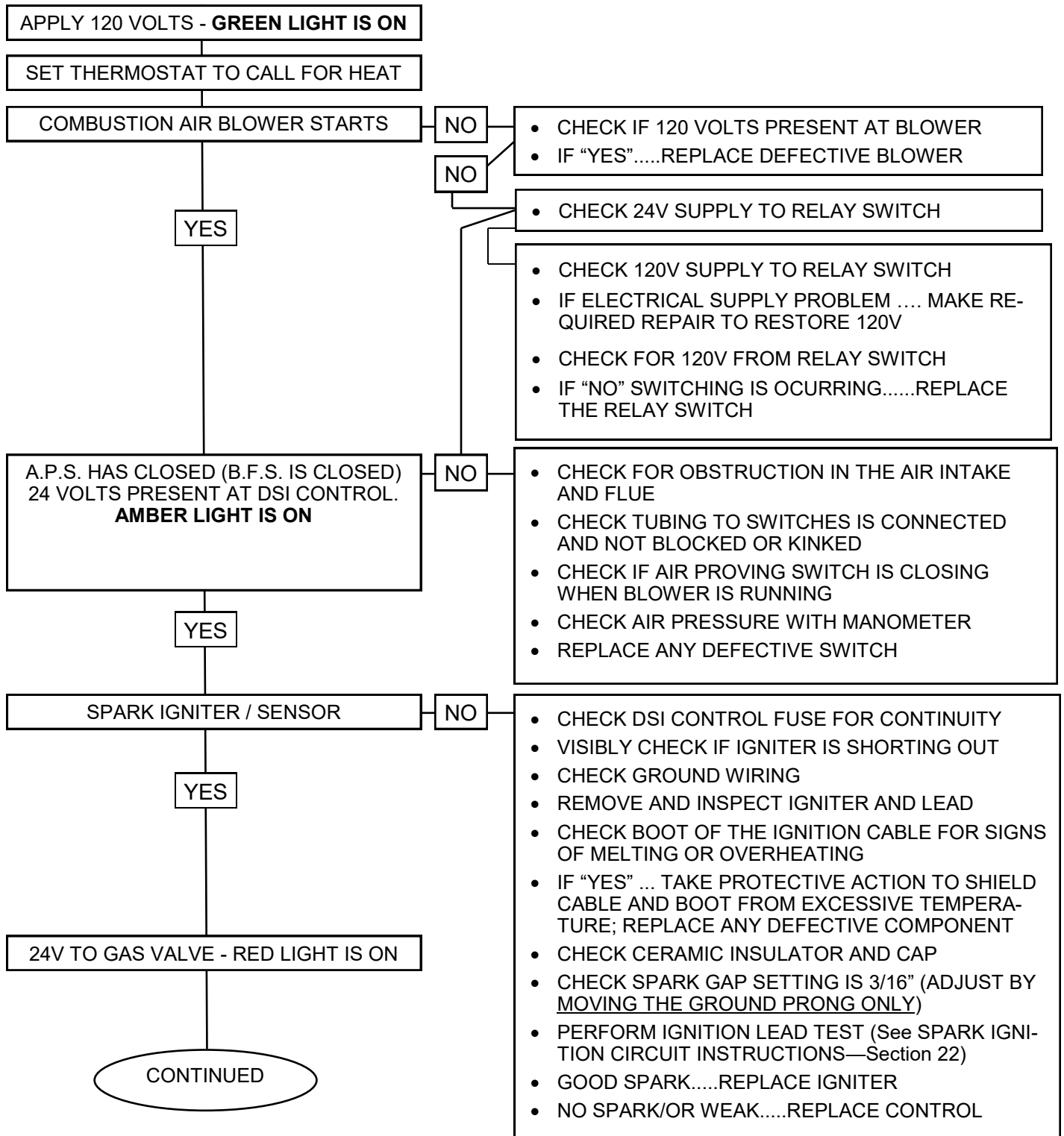

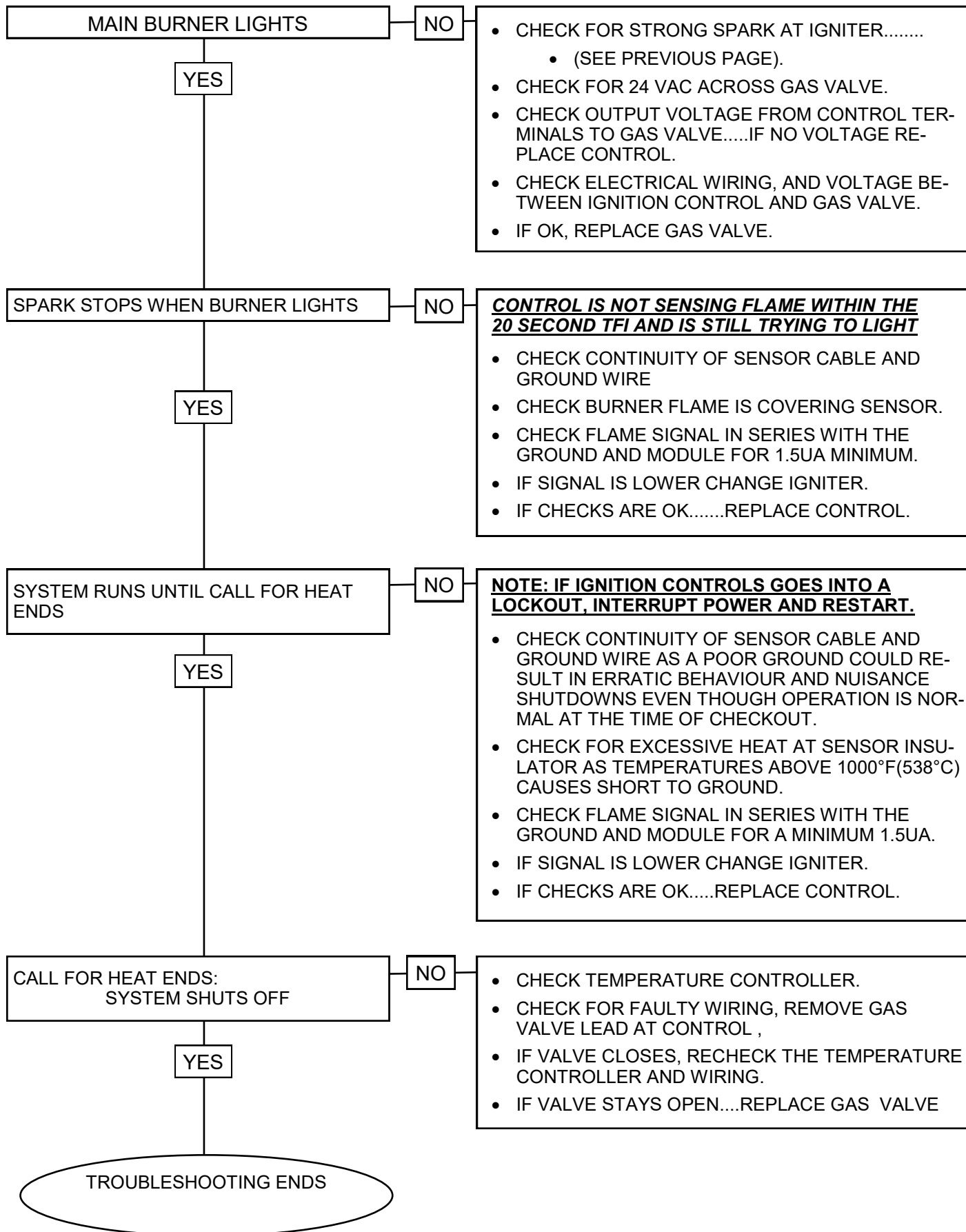

22. SPARK IGNITION CIRCUIT

The step-up transformer in the ignition control provides spark ignition at 30,000 volts (open circuit). To check the spark ignition circuit, proceed as follows.

- Shut off gas supply to the gas control
- Disconnect the ignition cable at the ignition control stud terminal to isolate the circuit from the Spark Igniter or Igniter / Sensor
- Prepare a short jumper lead, using heavily insulated wire such as ignition cable



CAUTION

In the next step, DO NOT allow fingers to touch either the stripped end of the jumper or the stud terminal. This is a very high voltage circuit and electrical shock, personal injury, or death can result.

- Perform this test immediately upon energizing the system before the Ignition Control goes into safety lockout and interrupts the spark circuit. Touch one end of the jumper firmly to the ignition control GND terminal. (DO NOT remove the existing ground lead.) Slowly move the other end of the jumper wire toward the stud terminal on the Ignition Control to establish a spark.
- Pull the wire away from the stud and note the length of gap at which spark discontinues.
- A spark length of 1/8 in. (3 mm) or more indicates satisfactory voltage output. If no arc can be established, or the maximum spark is less than 1/8 in. (3 mm), and power to the Ignition Control input terminals was proved, replace the Ignition Control.

TURN OFF THE POWER AND RECONNECT THE IGNITION WIRE TO THE IGNITION CONTROL STUD. DISCONNECT THE IGNITION WIRE FROM THE IGNITER AND REPEAT THE STEPS ABOVE BY GROUNDING THE WIRE OUT TO THE TUBE BODY THIS TIME. TURN ON THE POWER AND PULL THE WIRE AWAY FROM THE TUBE AND NOTE THE LENGTH OF GAP AT WHICH THE SPARK DISCONTINUES. IF THERE IS NO SPARK OR WEAK SPARK REPLACE THE IGNITION WIRE.

SPARK IGNITER SET UP

Use the following diagram to check the Igniter gap. If the gap is incorrect all adjustments should be made with the **GROUND PRONG/PIN ONLY!** **DO NOT BEND THE IGNITER PRONG!!!!**

USE THE BLACK BARS BELOW AS A GUIDE FOR ADJUSTMENT. USE THE BARS THAT COINCIDE WITH THE FORMAT & SIZE OF THIS PUBLICATION.

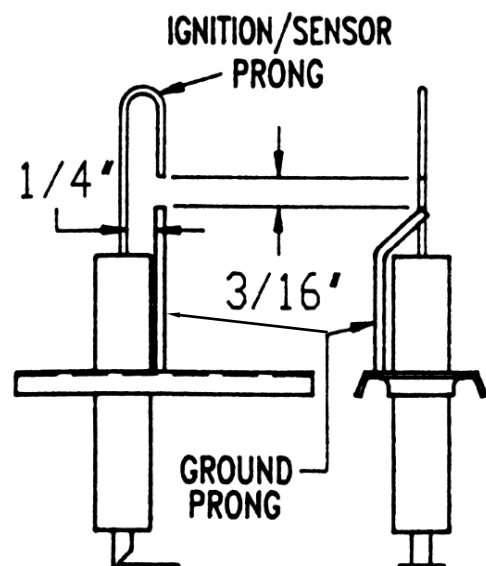
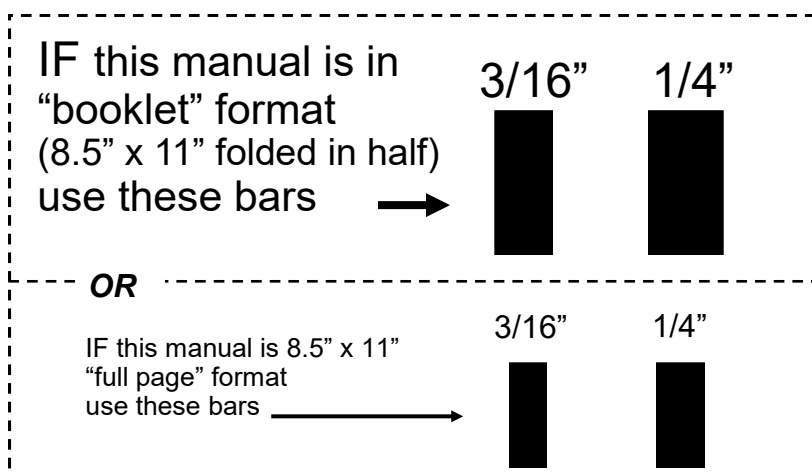

24. START-UP / COMMISSIONING SHEET



THIS EQUIPMENT HAS BEEN FACTORY FIRED AND TESTED PRIOR TO SHIPMENT. HOWEVER, THIS APPLIANCE IS NOT “PLUG & PLAY”. IT REQUIRES COMMISSIONING AND FIELD ADJUSTMENT / SPECIFICATIONS CONFIRMATION TO ENSURE SAFE AND EFFICIENT OPERATION.

**COMMISSIONING REPORT
AS PER I&O MANUAL AND LOCAL CODES**

CONTRACTOR NAME:**DATE**.....

ADDRESS:.....

.....

CITY:.....

PHONE:.....

CELL:

JOB SITE.....**CITY**.....

HEATER MODEL NUMBER:.....
Located on burner rating plate

HEATER SERIAL NUMBER:
Located on burner rating plate

TO ENSURE THAT SITE CONDITIONS ARE COMPATIBLE WITH THE HEATER’S PERFORMANCE AND TO ALLEVIATE NUISANCE CALL-BACKS, THE FOLLOWING START-UP NEEDS TO BE COMPLETED BY THE QUALIFIED GAS INSTALLER.

A TECHNICIAN CALLING FOR TECHNICAL SUPPORT MUST PROVIDE THE INFORMATION FROM THE COMPLETED COMMISSIONING REPORT ON THE NEXT PAGE

**FAX COMPLETED REPORT TO TECHNICAL SERVICES:
FAX 1-866-361-0523,
VOICE 1-877-446-3727**



WARNING

START UP ‘SMOKE’

During start up, material coatings used in the production process of tubes and reflectors will “burn off” and create smoke during the first hour of operation. This is temporary and normal. Please ensure that there is sufficient ventilation to adequately clear the smoke from the space. Notify site and safety personnel to ensure that alarm systems are not unduly activated.

**QUALIFIED INSTALLER TO COMPLETE THIS
TUBE HEATER COMMISSIONING REPORT**

TYPE OF GAS: NG LP

DOES BUILDING HAVE A NEGATIVE CONDITION: YES NO

IF THIS IS A HIGH ALTITUDE AREA WHAT IS THE ALTITUDE ABOVE SEA LEVEL Ft

DOES APPLICATION REQUIRE FRESH AIR TO BURNER YES NO

IS HEATER EXPOSED TO CHEMICAL OR CORROSIVE ATMOSPHERE: YES NO

ARE ACTUAL MINIMUM CLEARANCES AS PER TABLE 3 YES NO

CAN HEATER BE AFFECTED BY OVERHEAD CRANES / VIBRATION YES NO

ARE GAS SUPPLY LINES ADEQUATELY SIZED FOR SYSTEM YES NO

GAS LINES AND BRANCHES HAVE BEEN PURGED OF AIR: YES NO

THIS HEATER FIRED WITHOUT ANY MALFUNCTION: YES NO

INLET GAS SUPPLY PRESSURE WITH HEATER OPERATING : WC"

GAS VALVE OUTLET (Manifold) PRESSURE WITH HEATER OPERATING: WC"

WHAT IS THE LINE VOLTAGE READING AT THE HEATER VOLTS

WHAT IS THE VOLTAGE READING AT THE IGNITION MODULE VOLTS

WHAT IS THE FLAME SIGNAL STRENGTH IN uA FROM SENSOR: uA (microamps)

IS HEATER CONTROLLED BY A THERMOSTAT YES NO

IS THE THERMOSTAT STRATEGICALLY LOCATED YES NO

WHAT IS TOTAL LENGTH OF INSTALLED THERMOSTAT WIRE FEET

WHAT IS THE GAUGE OF THE THERMOSTAT WIRE GAUGE

WHAT IS THE HEATER TUBE LENGTH (10ft per Tube section) FEET

WHAT IS THE TOTAL LENGTH OF THE VENT (add 10ft for each bend) FEET

WHAT LENGTH IS COMBUSTION AIR INTAKE (add 10ft for each bend) FEET

IF REQUIRED....WHAT IS THE LENGTH OF THE TURBULATOR(S) FEET

IF INSTALLED....IS TURBULATOR AT FLUE END OF SYSTEM YES NO

"MAXIMUM STACKING HEIGHT" SIGN(S) - POSTED AT THERMOSTAT(S)

THIS HEATER MUST BE ELECTRICALLY GROUNDED

FAX COMPLETED REPORT TO TECHNICAL SERVICES: FAX 1-866-361-0523, VOICE 1-877-446-3727

25. BTUH INPUT RATINGS AND CORRESPONDING DIMENSIONS

BTUH INPUT 0' TO 4500' ABOVE SEA LEVEL	NOMINAL LENGTH (FT)	OVERALL HEATER LENGTH* (FT)	APPROX NET WEIGHT** (LBS)
200,000	70	69' 8"	324
200,000	60	60'	282
200,000	50	50' 4"	239
175,000	70	69' 8"	324
175,000	60	60'	282
175,000	50	50' 4"	239
150,000	60	60'	282
150,000	50	50' 4"	239
150,000	40	40' 8"	197
125,000	50	50' 4"	239
125,000	40	40' 8"	197
125,000 NG ONLY	30	31'	154

BTUH INPUT 0' TO 4500' ABOVE SEA LEVEL	NOMINAL LENGTH (FT)	OVERALL HEATER LENGTH* (FT)	APPROX NET WEIGHT** (LBS)
110,000	50	50' 4"	239
110,000	40	40' 8"	197
110,000	30	31'	154
80,000	40	40' 8"	197
80,000	30	31'	154
80,000	20	21' 4"	111
60,000	30	31'	154
60,000	20	21' 4"	111
45,000	20	21' 4"	111
45,000	10	11' 8"	68

→ Manufactured and shipped in 10 ft lengths.

→ Swaged tube has approximate 4 inch (10 cm) overlap -

- Net length of first and intermediate tubes is 116 inches (295 cm)
- Last tube is 120" (305 cm) [the 4 inch swage length is exposed for vent connection]
- Total tube length is approximately 4 inches (10 cm) shorter for each multiple of 10 feet (305 cm)
- Overall length of heater includes the burner.

** Burner weight is 26 pounds (11.8 kg)

Each 10 ft (305 cm) tube/reflector section weighs 82 pounds (37.2 kg)

FIGURE 21 BURNER DIMENSIONS

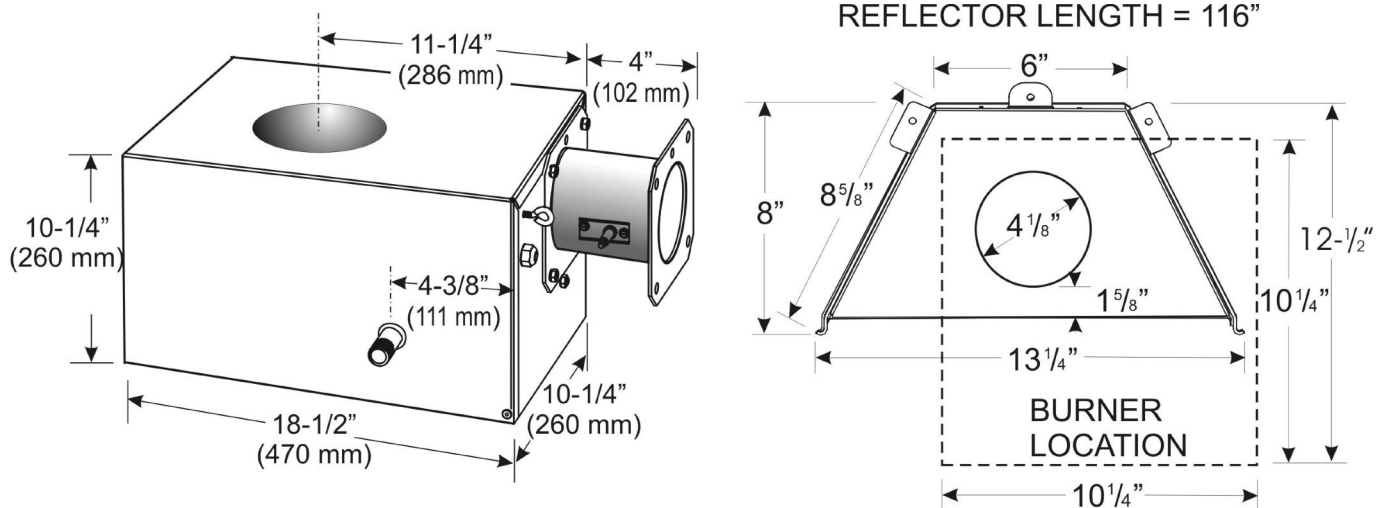
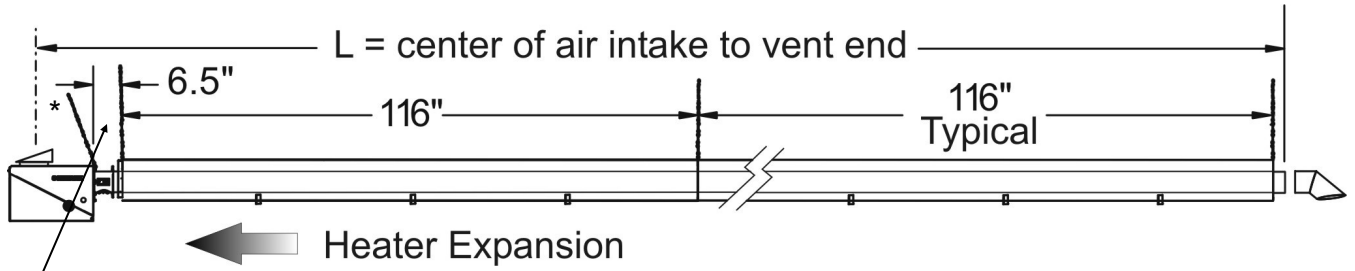

FIGURE 22 HANGER SPACING / AIR INTAKE TO VENT LENGTH



- POSITION BURNER END HANGER 6.5 INCHES (17 CM) FROM BURNER [2.5 INCHES (6.4 CM) FROM TUBE FLANGE]
- POSITION SYSTEM HANGERS 116 INCHES (295 CM) APART
- * ANGLE BURNER SUPPORT CHAIN BACK OVER BURNER - ALLOWS TUBE SYSTEM EXPANSION

Tube Length	'L' = center air intake to end			Tube Length	'L' = center air intake to end		
10'	11'-3 3/4"	; 135 3/4"	; 345 cm	50'	49'-11 3/4"	; 599 3/4"	; 1523 cm
20'	20'-11 3/4"	; 251 3/4"	; 628 cm	60'	59'-7 3/4"	; 715 3/4"	; 1818 cm
30'	30'-7 3/4"	; 367 3/4"	; 934 cm	70'	69'-3 3/4"	; 831 3/4"	; 2113 cm
40'	40'-3 3/4"	; 483 3/4"	; 1229 cm				

FIGURE 8 HANGER / REFLECTOR ORIENTATION HORIZONTAL TO 45°

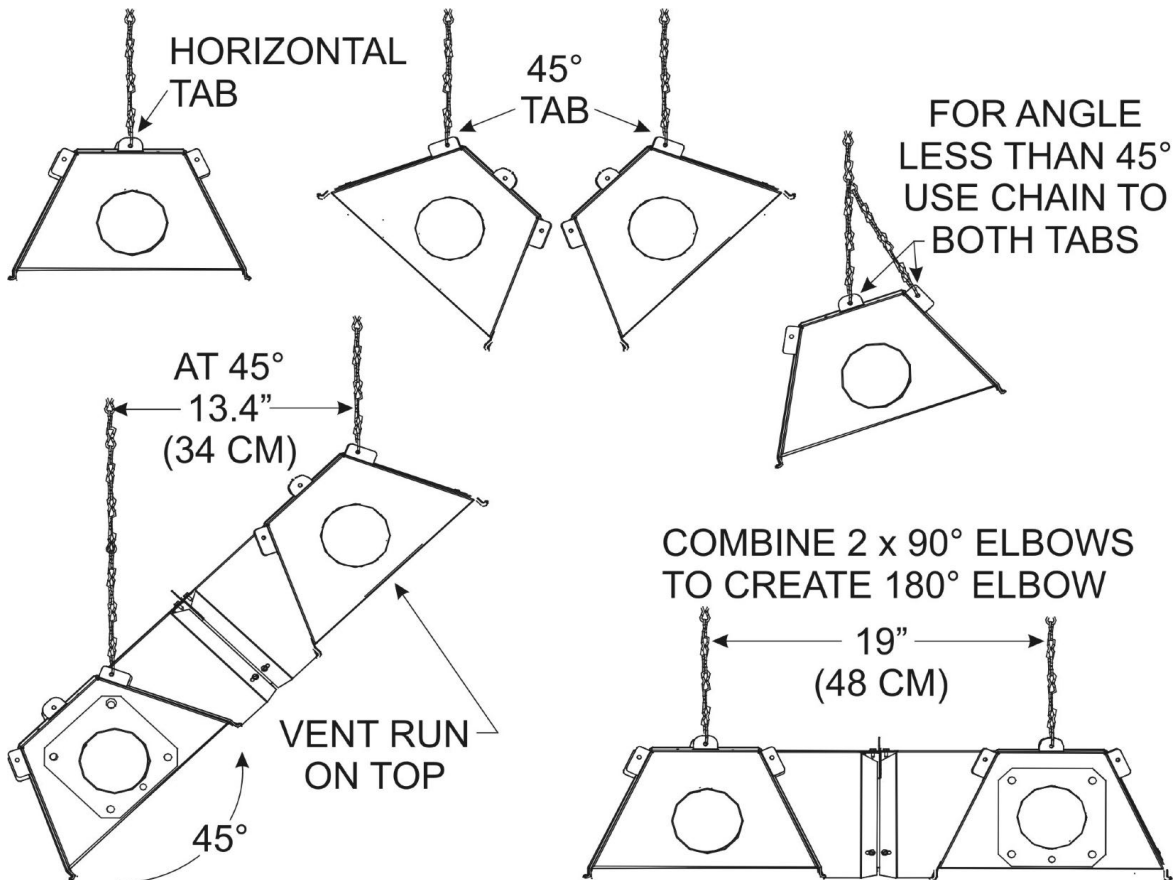

26. INPUT & TUBE KIT(S) REQUIRED



BEFORE INSTALATION:

ENSURE you have the CORRECT TUBE KIT(s) for the BURNER INPUT

CAPACITY INPUT (Btuh)	TUBE LENGTH	SPW-JZ / IWP & STW-JZ / IW ALUMINIZED STEEL TUBE KITS (individual cartons)		STWS / IWS STAINLESS STEEL TUBE KITS (individual cartons)	
		Tube Kit 1 #	Tube Kit 2 #	Tube Kit 1 #	Tube Kit 2 #
45,000	20'	TW-1420-JZ	-	TW-1420-JZ2	-
60,000	20'	TW-1420-JZ	-	-	-
	30'	TW-1430-JZ	-	TW-1430-JZ2	-
80,000	20'	TW-1420-JZ	-	-	-
	30'	TW-1430-JZ	-	TW-1430-JZ2	-
	40'	TW-1040-JZ	-	TW-1040-JZ2	-
110,000	30'	TW-1430-JZ	-	-	-
	40'	TW-1040-JZ	-	TW-1040-JZ2	-
	50'	TW-F030-JZ	TW-0020-JZ	TW-F030-JZ2	TW-0020-JZ2
125,000 NG ONLY	30'	TW-1430-JZ	-	-	-
125,000 NG & Propane	40'	TW-1040-JZ	-	TW-1040-JZ2	-
	50'	TW-F030-JZ	TW-0020-JZ	TW-F030-JZ2	TW-0020-JZ2
150,000	40'	TW-1040-JZ	-	-	-
	50'	TW-F030-JZ	TW-0020-JZ	TW-F030-JZ2	TW-0020-JZ2
	60'	TW-F030-JZ	TW-0030-JZ	TW-F030-JZ2	TW-0030-JZ2
175,000	50'	TW-1030-JZ	TW-0020-JZ	-	-
	60'	TW-1030-JZ	TW-0030-JZ	TW-1030-JZ2	TW-0030-JZ2
	70'	TW-1030-JZ	TW-0040-JZ	TW-1030-JZ2	TW-0040-JZ2
200,000	50'	TW-1030-JZ	TW-0020-JZ	-	-
	60'	TW-1030-JZ	TW-0030-JZ	TW-1030-JZ2	TW-0030-JZ2
	70'	TW-1030-JZ	TW-0040-JZ	TW-1030-JZ2	TW-0040-JZ2

FLEXIBLE GAS CONNECTOR (Included in Burner Kit) - MUST INSTALL - see Section 13

USA - Stainless Steel Flexible Gas Connector

125,000 or less:
JL-0771-XX - 1/2"x24"

150,000 or more:
JL-0771-YY - 3/4"x36"



CANADA - Type 1 Hose Gas Connector

125,000 or less:
JL-0771-RC - 1/2"x30"

150,000 or more:
JL-0771-RB - 3/4"x36"



28. HIGH ALTITUDE INSTALLATION

Canada: Heaters can be installed to an altitude of 4500 ft without revision.

- To install above 4500 feet refer to recommendation of local authority having jurisdiction.

USA: The factory installed orifice is approved for normal altitude up to 2000 ft.

When this appliance is installed above an altitude of 2000 feet in the USA, the input must be de-rated by 4% for each 1000 ft. Refer to the table next page for orifice sizing and restrictions that apply to high altitude installation. Check with your local authority regarding de-rating.

NOTE: Installations above 4,500 ft: Restrict the Total Combined System Length as indicated in the TOTAL SYSTEM LENGTH RESTRICTIONS Table below.

MINIMUM VENT LENGTH: (Vented or Unvented [indirect mechanical ventilation])

- Minimum vent length of 3 ft (91 cm) is required (**NOTE:** 200,000 Propane: Minimum 8 ft (244 cm))

MAXIMUM SYSTEM LENGTH (includes: Tube Heater length + combustion air duct + vent):

- Each 90° elbow in the system has an equivalent length of 5 ft.
- A maximum of 2 elbows are allowed in any portion (duct, tube heater, vent) with the exception of up to three 90° elbows in a vertical vent run through the roof
- Combustion air duct may be 4" or 5" diameter and is not to exceed lengths in table below
- Exceeding the allowable lengths in the table below can create combustion and/or condensation problems and will void CSA Certification and the heater warranty.
- Do not exceed the **Maximum Combined System Length** regardless of the allowed maximum length of individual vent or combustion air duct

**TABLE 8: TOTAL SYSTEM LENGTH RESTRICTIONS:
INSTALLATIONS ABOVE 4500 FEET (Lower altitudes refer to Section 12A)**

Input (Btuh)	Do Not Exceed Maximum Combined System Length		Max. Air Duct Length (ft) (by Duct Diameter)		Max. Vent Length (ft) Individual: 4"Ø Combined: 6"Ø	Example
	4" Air Duct	5" Air Duct	4"Ø	5"Ø		
45,000 & 60,000	40 ft	60 ft	20 ft	40 ft	20 ft	150,000 Btuh Heater: Tube Heater Length 40 ft 1 x 90° elbow (vent) 5 ft Straight vent 15 ft 1 x 90° elbow (duct) 5 ft Air Duct: 4" Ø <u>13 ft</u> Combined Length 78 ft Max. Allowed 80 ft Additional 20' for 5" Ø Air Duct
80,000	50 ft	70 ft	20 ft	40 ft	20 ft	
100,000	40 ft	60 ft	30 ft	50 ft	30 ft	
110,000 to 150,000	80 ft	100 ft	30 ft	50 ft	40 ft	
175,000 & 200,000	100 ft	120 ft	30 ft	50 ft	50 ft	

29 HIGH ALTITUDE INSTALLATION - ORIFICE CHART

Altitude Restrictions this Model: - also see notes previous page

1. Do not install the 45,000 Btuh model at altitudes greater than 4,500 ft
2. Do not install other input models at altitudes greater than 8,000 ft
3. Restrict the length of any model to the shortest tube length at altitudes greater than 4,000 ft

INPUT (BTUH)	FOR USE AT ALTITUDES ABOVE (FEET)							
	Gas Orifice Drill Size / Part#							
	Supplied	USA						
	0 - 2000	2000	3000	4000	4500	5500	6500	7500
45,000 NG	29 DMS JS-0729-DM	29 DMS JS-0729-DM	30DMS JS-0730-DM	30DMS JS-0730-DM	45,000 Btuh not for use above 4,500 feet			
45,000 Propane	46 DMS JS-0746-DM	46 DMS JS-0746-DM	46 DMS JS-0746-DM	48 DMS JS-0748-DM				
60,000 NG	25 DMS JS-0725-DM	26 DMS JS-0726-DM	27 DMS JS-0727-DM	27 DMS JS-0727-DM	28 DMS JS-0728-DM	28 DMS JS-0728-DM	29 DMS JS-0729-DM	29 DMS JS-0729-DM
60,000 Propane	42 DMS JS-0742-DM	42 DMS JS-0742-DM	43 DMS JS-0743-DM	43 DMS JS-0743-DM	43 DMS JS-0743-DM	44 DMS JS-0744-DM	44 DMS JS-0744-DM	45 DMS JS-0745-DM
80,000 NG	18 DMS JS-0718-DM	19 DMS JS-0719-DM	19 DMS JS-0719-DM	20,000 DMS JS-0720-DM	21 DMS JS-0721-DM	22 DMS JS-0722-DM	23 DMS JS-0723-DM	24 DMS JS-0724-DM
80,000 Propane	36 DMS JS-0736-DM	38 DMS JS-0738-DM	39 DMS JS-0739-DM	39 DMS JS-0739-DM	40 DMS JS-0740-DM	41 DMS JS-0741-DM	42 DMS JS-0742-DM	42 DMS JS-0742-DM
110,000 NG	5.2 mm JS-0752-MM	5.1 mm JS-0751-MM	5.0 mm JS-0750-MM	9 DMS JS-0709-DM	11 DMS JS-0711-DM	0.19 i n JS-0719-IN	13 DMS JS-0713-DM	14 DMS JS-0714-DM
110,000 Propane	31 DMS JS-0731-DM	32 DMS JS-0732-DM	32 DMS JS-0732-DM	32 DMS JS-0732-DM	33 DMS JS-0733-DM	34 DMS JS-0734-DM	35 DMS JS-0735-DM	36 DMS JS-0736-DM
125,000 NG 30 & 40 ft	5.8 mm JS-0758-MM	5.7 mm JS-0757-MM	5.6 mm JS-0756-MM	5.5 mm JS-0755-MM	3 DMS JS-0703-DM	4 DMS JS-0704-DM	5 DMS JS-0705-DM	0.20 in JS-0720-IN
125,000 Propane 40 ft ONLY	29 DMS JS-0729-DM	29 DMS JS-0729-DM	30 DMS JS-0730-DM	30 DMS JS-0730-DM	30 DMS JS-0730-DM	1/8" JS-0713-IN	31 DMS JS-0731-DM	31 DMS JS-0731-DM
150,000 NG	0.25 in JS-0725-IN	6.4 mm JS-0764-MM	6.3 mm JS-0763-MM	6.2 mm JS-0762-MM	6.1 mm JS-0761-MM	6.0 mm JS-0760-MM	5.9 mm JS-0759-MM	5.8 mm JS-0758-MM
150,000 Propane	0.14 in JS-0714-IN	3.5 mm JS-0735-MM	29 DMS JS-0729-DM	3.4 mm JS-0734-MM	3.3 MM JS-0733-MM	3.3 MM JS-0733-MM	30 dms JS-0730-DM	0.13 in JS-0713-IN
175,000 NG	6.7 mm JS-0767-MM	6.6 mm JS-0766-MM	6.6 mm JS-0766-MM	6.5 mm JS-0765-MM	6.5 mm JS-0765-MM	6.4 mm JS-0764-MM	6.3 mm JS-0763-MM	6.3 mm JS-0763-MM
175,000 Propane	24 DMS JS-0724-DM	25 DMS JS-0725-DM	26 DMS JS-0726-DM	27 DMS JS-0727-DM	28 DMS JS-0728-DM	28 DMS JS-0728-DM	29 DMS JS-0729-DM	29 DMS JS-0729-DM
200,000 NG	0.30 in JS-0730-IN	7.4 mm JS-0774-MM	7.3 mm JS-0773-MM	7.3 mm JS-0773-MM	7.2 mm JS-0772-MM	0.28 in JS-0728-IN	7.1 mm JS-0771-MM	7.0 mm JS-0770-MM
200,000 Propane	19 DMS JS-0719-DM	20 DMS JS-0720-DM	20 DMS JS-0720-DM	21 DMS JS-0721-DM	22 DMS JS-0722-DM	23 DMS JS-0723-DM	25 DMS JS-0725-DM	26 DMS JS-0726-DM

30. OPTIONAL ACCESSORIES

Flue Vent Terminal

4" wall horizontal
6" wall horizontal

JA-0528-XX
JA-0529-XX



Torctite Coupler (c/w 2 bolts)

JA-0516-SW



Vent Tee 4" X 4" X 6" (2 couplers optional)

JA- 0514-XX

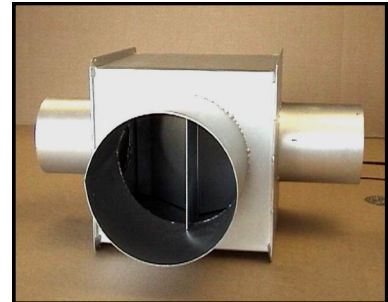

Clearance Sign

- Required in some jurisdictions:

- Vehicle service garages
- 3/4" high red lettering on white background

JL-0798-CS

WARNING
**MAINTAIN ___" CLEARANCE FROM
TUBE HEATER TO VEHICLES
AND COMBUSTIBLE MATERIALS**

90 degree Elbow Kit*

• **Aluminized Steel JS-0508-JZ**

- *Kit includes: 1. elbow,
 2. tube coupler,
 3. reflector end cap,
 4 screws,
 5. reflector cap.

See dimensions below

For 180 degree elbow applications
 order 2 x 90 degree Elbow kits.

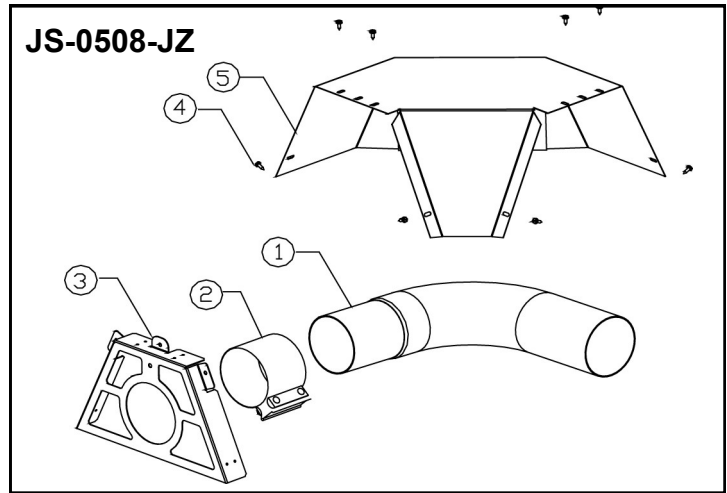

90° Elbow Kit JS-0508-JZ

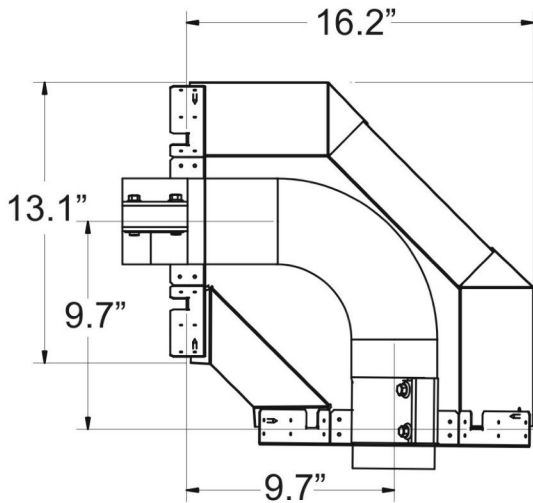

2 x 90° Elbow Kit = 180° Elbow

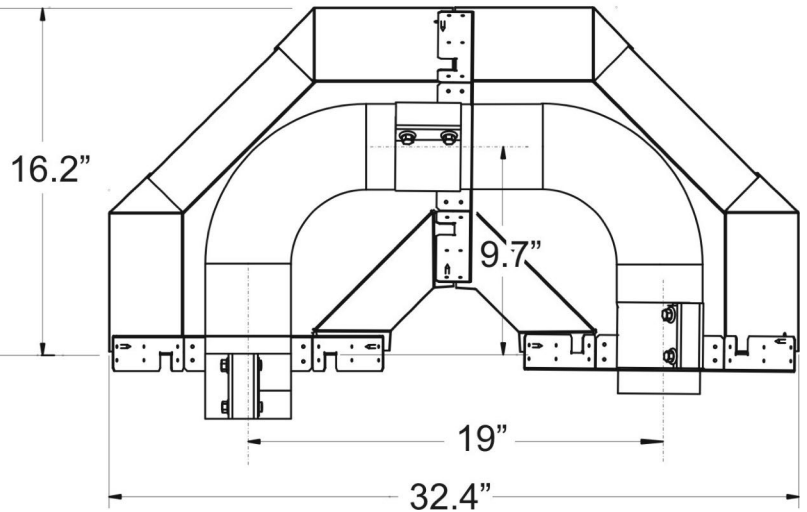

<p>Side Reflector Extension Kit- 10" deep, 10 ft long Each</p>	<p>JS-0509-KT</p>	
<p>Tube Protection Screen -5 foot lengths</p>	<p>JA-0780-XX</p>	

#2 Lion Chain (115 lb work load)
- 200 ft roll

JL-0800-XX



Safety Snap Hooks - 2" - package of 25
- package of 100



JL-0800-SH
JL-0800-SH-B

Moisture Proof Thermostat - NEMA 4X

SPDT Line Voltage
40° - 110°F (5° - 40°C)
Both °F & °C Scales
Voltage: 24 - 277 Vac
Differential: 3°F
Stainless Steel Bulb
UL Listed

JS-0570-XX



TruTemp Thermostat

True comfort control for radiant heating systems
- senses and averages ambient and radiant temperatures.

Occupancy sensor = auto set-back of 9°F (5°C).

Do not use in wet or corrosive environments

JM-0150-XX



Low Voltage Digital Thermostat
(24 Volts - °F or °C selectable)

Not for use in corrosive or wet environments

JS-0569-WR

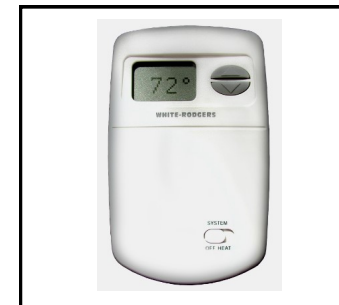

Multiple Heaters per 24V Thermostat

Relay Switch: One required for each burner after the first burner in a zone (1st burner connects to 24V thermostat)

Refer to wiring diagram Page 37

(field installed at or in burner)

JM-0303 -KT



Line Voltage Thermostat:

Dual Scale: °F or °C

Not for use in corrosive or wet environments

JL-0772-XX



31. REPLACEMENT PARTS

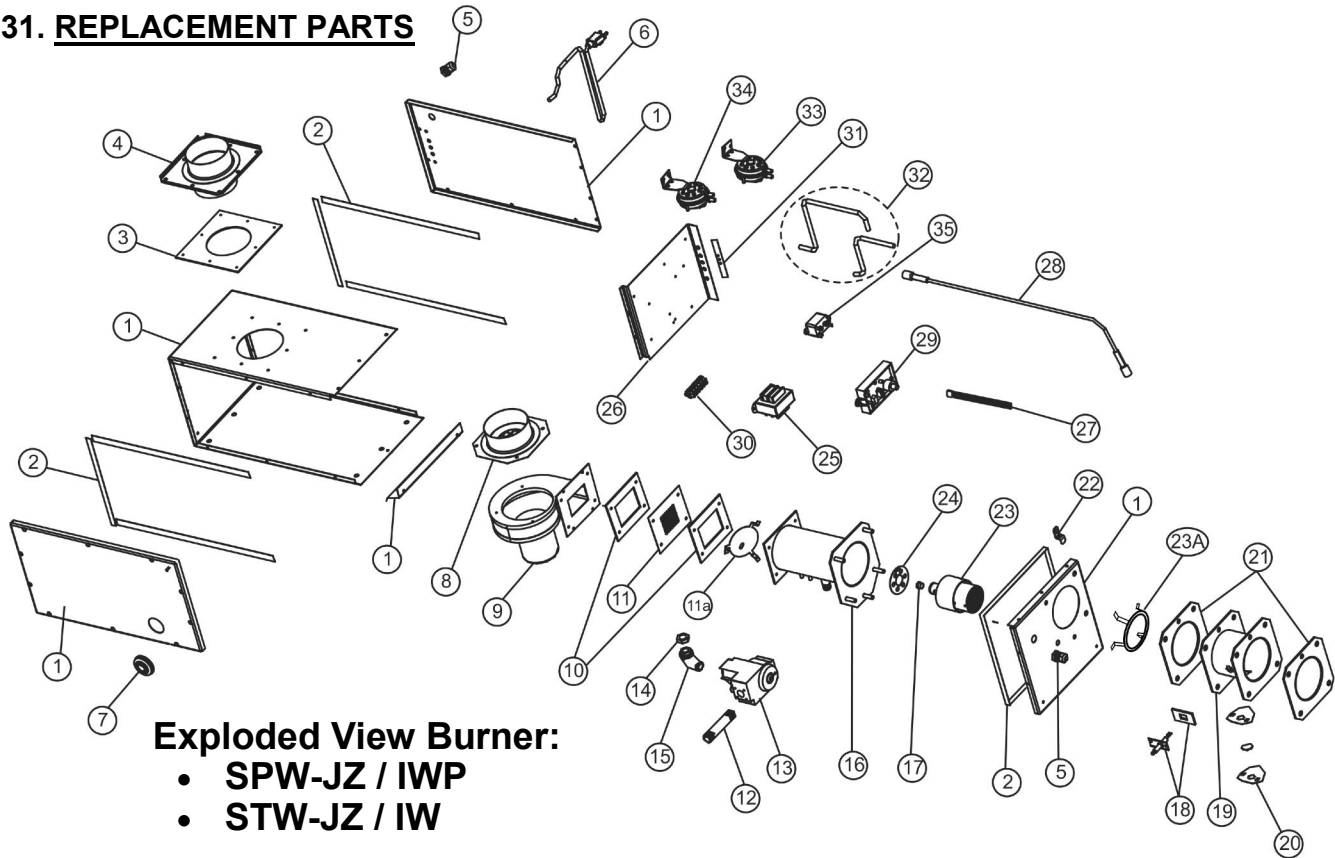

Exploded View Burner:
 • SPW-JZ / IWP
 • STW-JZ / IW

#	PART DESCRIPTION	INPUT (Mbh)	MODEL DASH #/ GAS TYPE	PART #	PART DESCRIPTION PRIMARY
1	BURNER HOUSING	ALL	STW-JZ(2) / IW(2)	JS-0582-WP	Burner housing harsh environment
		ALL	SPW-JZ / IWP	JS-0582-WP-P	Powder coated burner housing wet environments
2	BURNER HOUSING GASKET SET	ALL		JS-0591-WP	Housing gasket set
3	AIR INTAKE GASKET	ALL		JS-0601-WP	Air intake gasket (Each)
4	COMBUSTION AIR CONNECTION	ALL		JS-0583-15	4 inch Combustion air Connection
4A	COMBUSTION AIR CAP	ALL		JS-0532-SE	4 inch Combustion air Cap - Birdscreened
5	SEALTIGHT CON-NECTOR	ALL		JP-2036-XX	Connector liquid tight
6	ELECTRICAL CORD	ALL		JB-0567-XX	Electrical cord
7	WATERPROOF GROM-MET	ALL		JP-2101-XX	Water proof butt connectors
8	BLOWER COMBUS-TION AIR INLET	45	NG	JS-0594-SC	Blower Restrictor Ring c/w Flange
		45	Propane	JS-0594-ST	Blower Restrictor Ring c/w Flange
		60		JS-0594-ST	Blower Restrictor Ring c/w Flange
		80		JS-0595-SP	Blower Restrictor Ring c/w Flange
		80	-B	JS-0594-SC	Blower Restrictor Ring c/w Flange
		110	-B	JS-0595-AE	Blower Restrictor Ring c/w Flange
		110-200		JS-0595-AA	Blower Restrictor Ring c/w Flange
9	BLOWER	45-175		JS-0579-AK	Blower Assembly 1/35 HP w/ Gaskets
		200		JS-0579-ZK	Blower Assembly 1/20 HP w/ Gaskets
10	BLOWER GASKET	ALL		JS-0578-XX	Outlet blower gasket (Each)

#	PART DESCRIPTION	INPUT (Mbh)	MODEL DASH #/ GAS TYPE	PART #	PART DESCRIPTION PRIMARY
11	EQUALIZER PLATE	45	-X1; Propane	JS-0593-XL	Outlet equalizer plate - 29 Holes
		45	-X1; NG	JS-0593-NG	Outlet equalizer plate - 25 Holes
		60-155	NG	JS-0593-XX	Outlet equalizer plate
		60-155	Propane	JS-0593-XX	Outlet equalizer plate
		175	Propane	JS-0593-XZ	Outlet equalizer plate
		175-200	NG; 200 Propane	JS-0593-XX	Outlet equalizer plate
11 A	AIR RESTRICTOR	45	-X1	JS-0592-AR	Burner air restrictor (45-X1)
		175	-S; Propane	JS-0591-XY	Burner air restrictor (175-S LP)
12	4" NIPPLE	ALL		JS-0590-GA	4" nipple
13	GAS VALVE	45-155	NG	JL-0701-AA	Comb. Gas Valve 3.5" W.C. NG - 24VAC
		45-155	Propane	JL-0703-AA	Comb. Gas Valve 10" W.C LP - 24VAC
		175-200	NG	JA-0506-XX	Slow Open Gas Valve 3.5" WC NG - 24Vac
		175-200	Propane	JA-0507-XX	Slow Open Gas Valve 10" WC LP - 24Vac
14	MANIFOLD BUSHING	ALL		JS-0589-XX	Manifold bushing
15	90 DEGREE ELBOW FITTING	ALL		JS-0588-XX	1/2" x 90 degree street elbow fitting
16	OUTER BURNER	ALL		JS-0504-WP	Outer burner assembly
17	MAIN BURNER ORIFICE	45	Propane	JS-0748-DM	Gas orifice low intensity HR 48 DMS
		45	NG	JS-0730-DM	Gas orifice low intensity HR 30 DMS
		60	Propane	JS-0742-DM	Gas orifice low intensity HTR 42 DMS
		60	NG	JS-0725-DM	Gas orifice low intensity HTR 25 DMS
		80	Propane	JS-0736-DM	Gas orifice low intensity HTR 36 DMS
		80	NG	JS-0718-DM	Gas orifice low intensity HTR 18 DMS
		110	Propane	JS-0731-DM	Gas orifice low intensity HTR 31 DMS
		110	NG	JS-0752-MM	Gas orifice low intensity HTR 5.2 mm
		125	Propane	JS-0729-DM	Gas orifice low intensity HTR 29 DMS
		125	NG	JS-0758-MM	Gas orifice low intensity HTR 5.8 mm
		155	Propane	JS-0714-IN	Gas orifice low intensity HTR 9/64 inch
		155	NG	JS-0725-IN	Gas orifice low intensity HTR 1/4 inch
		175	Propane	JS-0724-DM	Gas orifice low intensity HTR 24 DMS
		175	NG	JS-0767-MM	Gas orifice low intensity HTR 6.7 mm
		200	Propane	JS-0719-DM	Gas orifice low intensity HTR 19 DMS
		200	NG	JS-0730-IN	Gas orifice low intensity HTR 19/64 inch
18	IGNITER KIT	ALL		JA-0571-KT	Igniter & gasket kit / DSI tube heater
19	FLANGE ADAPTER	ALL		JS-0500-ZZ	4" flanged adapter - Stainless Steel
20	SIGHT GLASS ASSEMBLY	ALL		JS-0536-XX	Sight glass assembly
21	FLANGE GASKET	ALL		JS-0591-XX	Flange gasket (Each)
22	BURNER STABILIZING BRACKET	ALL		JS-0583-05	Burner suspension bracket
23	BURNER CUP	45	NG; Propane	JS-0510-LP-45	Burner Cup w/ Center Hole
		60-80	NG; Propane	JS-0510-LP	Burner Cup
		110-155	NG; Propane	JS-0512-XX	Burner Cup
		175	NG	JS-0512-XX	Burner Cup
		175	Propane	JS-0512-UL	Burner Cup - Cast Aluminum - No Hole
		200	NG; Propane	JS-0512-UL	Burner Cup - Cast Aluminum - No Hole

#	PART DESCRIPTION	INPUT (Mbh)	MODEL DASH # / GAS TYPE	PART #	PART DESCRIPTION PRIMARY
23A	FLAME RECTIFIER	110-125	-B; NG; Propane	JS-0592-RT	Flame Rectifier 125 Mbh Burner - 130-FB
		200	Propane	JS-0592-RX	Flame Rectifier 200-S LP
24	BURNER CUP AIR RESTRICTOR RING	45	NG; Propane	JS-0596-AA	Burner Cup air restr ring 9/32"
		60	Propane	JS-0596-XX	Burner Cup air rest ring 0.375
		60-175	NG	JS-0596-XX	Burner Cup air rest ring 0.375
		80-155	Propane	JS-0597-XX	Burner head air rest. ring .500
		175	-S; Propane	JS-0597-XY	Burner Cup air rest ring 175-S LP
		200	-S; Propane	JS-0597-YE	Burner Cup air rest ring 200-S LP
		200	-S; NG	JS-0597-YY	Burner Cup air rest ring 200-S NG
25	STEP DOWN TRANSFORMER	ALL		JA-0775-XX	Transformer 120/24V, 20VA AT120B1028
26	COMPONENT PLATE	ALL		JS-0583-41	Component Mounting Plate
27	IGNITION CONTROL WIRING HARNESS	ALL		JB-0568-WH	Potted DSI control wiring harness
28	IGNITION CABLE	ALL		JS-0518-FW	Hi voltage wire (24") STW - 2 x 1/4" Spades
29	IGNITION CONTROL	ALL		JB-0568-AA	Control - DSI 3 Try potted Gasliter 50N
29A	WIRING KIT Low Voltage (not shown)	ALL		JW-WXXX-HX	Wiring kit w/ Harness - harsh environment
30	TERMINAL BLOCK			JM-0455-DD	Terminal block
31	INDICATOR LAMPS			JW-0519-AM	Amber indicator light
				JW-0519-GR	Green indicator light
				JW-0519-RE	Red indicator light
32	PRESSURE SWITCH TUBING			JS-0572-SE	P.V.C. tubing set (2 x 20")
33	COMBUSTION AIR PROVING SWITCH	45	-C; -UH	JS-0576-XX	Air proving Switch 0.48" WC
		45	-X1	JS-0576-AA	Air proving Switch 0.85" WC
		60		JS-0576-YY	Air proving Switch 0.30" WC
		80		JS-0576-XX	Air proving Switch 0.48" WC
		110		JS-0575-YY	Air proving Switch 0.65" WC
		110	-B	JS-0575-ZB	Air proving Switch 0.90" WC
		130		JS-0575-YY	Air proving Switch 0.65" WC
		125	-B	JS-0576-UL	Air proving Switch 1.10" WC
		155		JS-0575-YY	Air proving Switch 0.65" WC
		150	-A	JS-0575-UG	Air proving Switch 1.00" WC
		175	-S; NG	JS-0576-AA	Air proving Switch 0.85" WC
		175	-S; Propane	JS-0576-XY	Air proving Switch 1.15" WC
		200	-S	JS-0575-ZA	Air proving Switch 1.40" WC
34	BLOCKED FLUE PRESSURE SWITCH	45	-X1	JS-0577-YY	Blocked flue switch 0.90" WC
		45	-C; -UH	JS-0577-ZZ	Blocked flue switch 1.41" WC
		60	NG; Propane	JS-0577-SS	Blocked flue switch 0.58" WC
		125	-B	JS-0577-XZ	Blocked flue switch 1.25" WC
		80-155	NG; Propane	JS-0577-YY	Blocked flue switch 0.90" WC
		175	-S; NG	JS-0577-ZZ	Blocked flue switch 1.41" WC
		175	-S; Propane	JS-0577-XY	Blocked flue switch 1.20" WC
		200	-S; NG	JS-0577-UW	Blocked flue switch 1.33" WC
		200	-S; Propane	JS-0578-BB	Blocked flue switch 1.50" WC
35	24V/120V RELAY SWITCH	ALL		JS-0568-CC	24V/120V Relay Switch

**TUBE SYSTEM PARTS:
SPW-JZ / IWP
STW-JZ / IW**

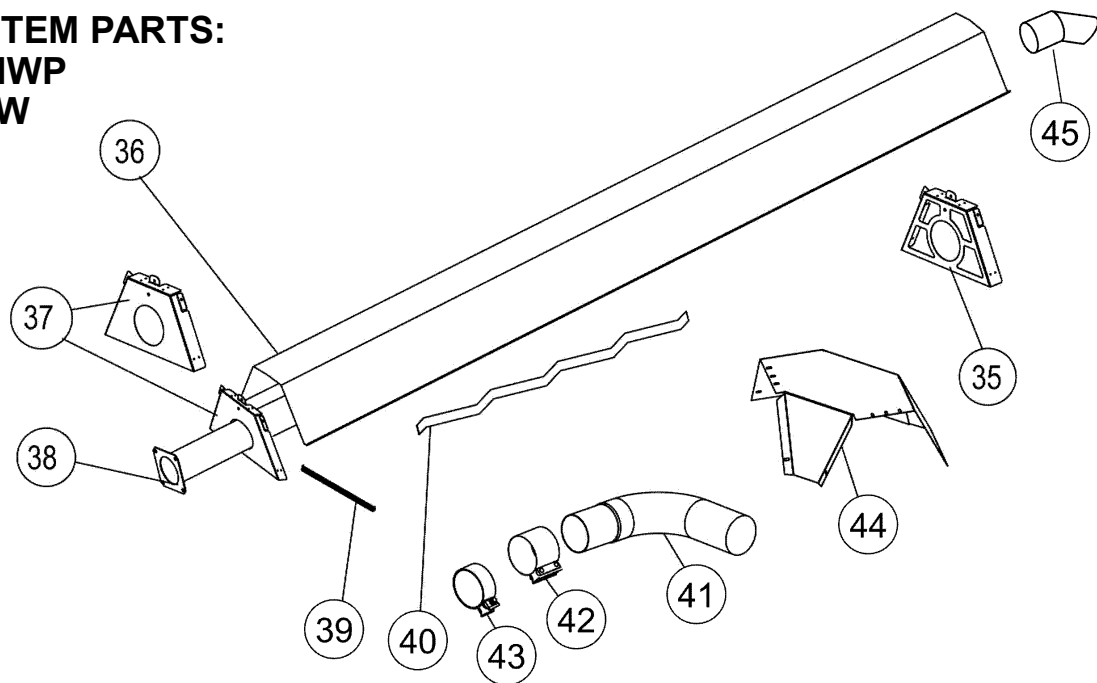

#	PART DESCRIPTION	INPUT (Mbh)	MODEL DASH # / GAS TYPE	PART #	PART DESCRIPTION PRIMARY
36	REFLECTOR:			JS-0502-JZ	Reflector 24" x 116" - Aluminized Steel
			STWS, IWS	JS-0502-SZ	Reflector 24" x 116" - Stainless Steel
37	PLATE HANGER:			JS-0506-JZ	Aluminized end plate hanger
			STWS, IWS	JS-0506-SZ	Stainless Steel end plate hanger
37A	WEBBED HANGER:			JS-0505-JZ	Webbed Hanger - Aluminized Steel
				JS-0505-SZ	Webbed Hanger - Stainless Steel
38	LOW INTENSITY TUBE:	45-155	1st Tube	JA-0501-SW-P	Aluminized tube, flange, swage, no ports
		175-200	1st Tube	JA-0500-SS-P	Stainless Steel tube, flange, swage, no ports
		175-200	2nd Tube	JS-0501-SK	Aluminized tube swaged c/w Coupler & Rivet
		45-200		JS-0511-SW-P	Painted aluminized tube swaged
		45-200	STWS, IWS	JS-0500-SW	Stainless Steel tube swaged
39	REFLECTOR BRACE:			JS-0506-RB	Reflector brace - Aluminized Steel
				JS-0506-SB	Reflector brace - Stainless Steel
40	TURBULATOR	45-80	20 ft	JS-0533-SH	Turbulator 4' Aluminized Steel
	<i>(see Table in STW-JZ I&O Manual)</i>	45-80	20 ft	JS-0533-LG	Turbulator 10' Aluminized Steel
		60-80	30 ft	JS-0533-SL	Turbulator 8 ft stainless steel
		110-125	-B; 30 ft	JS-0533-SS	Turbulator 5 ft stainless steel
		110-125	-B; 30 ft	JS-0533-SL	Turbulator 8 ft stainless steel
		80-150	-B; 40 ft	JS-0533-UA	Turbulator 2' Aluminized Steel
		110-150	-B; 50 ft	JS-0533-UA	Turbulator 2' Aluminized Steel
		175	60-70 ft	JS-0533-SH	Turbulator 4' Aluminized Steel
		175-200	50 ft	JS-0533-LG	Turbulator 10' Aluminized Steel
		175-200	60-70 ft	JS-0533-UG	Turbulator 6' Aluminized Steel
41	90° ELBOW 4":			JA-0508-SW	90 degree elbow - Aluminized Steel
			STWS, IWS	JA-0508-SS	90 degree elbow - Stainless Steel
42	COUPLER			JA-0516-SW	4" swaged tube coupler torcrite
43	COUPLER 175 & 200 Mbh	175-200	1st & 2nd Joints	JA-0516-RK	Coupler 4" with Rivet & Drill Bit
44	ELBOW REFLECTOR CAP:			JS-0503-US	Reflector Cap for 90° Elbow - Aluminized Steel
			STWS, IWS	JS-0503-SZ	Reflector Cap for 90° Elbow - Stainless Steel
45	VENT CAP			JA-0528-XX	4" horizontal wall vent terminal



FOR GAS-FIRED INFRA-RED LOW INTENSITY TUBE HEATERS: SPW-JZ & IWP SERIES

The Manufacturer warrants that this product is free from defects in material or workmanship under normal use and service subject to the terms of this document.

THREE YEAR WARRANTY

Subject to the conditions and limitations stated herein, during the term of this limited warranty, we will supply any component part (at our option a new or repaired component part) of the heater as defined below, excluding any labor, which the Manufacturer's examination determines to be defective in workmanship or material for a period of three years (3 years) from the date of installation, unless otherwise specified below. This warranty applies to the heater's original owner, and subsequent transferees and only if the unit is installed and operated in accordance with the printed instructions accompanying the unit and in compliance with all applicable installation codes and good trade practices. Warranty is only applicable to Schwank components, other parts are limited to their own Manufacturers warranty period of one year (1 year).

TEN YEAR WARRANTY

The Manufacturer warrants the burner sub-assembly comprising of ceramic and immediate metal tubing, and the aluminized steel radiating tubes (excluding couplings) for a period of ten years (10 years).

WHAT IS NOT COVERED

The Manufacturer shall not be responsible for any expenses, including service, labor, diagnosis, analysis, material or transportation charges incurred during removal or reinstallation of this product, or any of its components or parts. All labor or service charges shall be paid by the owner. This warranty does not cover heating products improperly installed, misused, exposed to or damaged by negligence, accident, corrosive or contaminating atmosphere, water, excessive thermal shock, impact, abrasion, normal wear due to use, alteration or operation contrary to the owner's manual or if the serial number has been altered, defaced or removed. This warranty shall not apply if the input to the heating product exceeds by more than 2% of the rated input on the rating plate. The Manufacturer shall not be liable for any default or delay in performance by its warranty caused by any contingency beyond its control, including war, government restrictions, or restraints, strikes, fire, flood, acts of God, or short or reduced supply of raw materials or products.

WARRANTY PROCEDURE

To establish the installation date for any purpose under this Limited Warranty, you must retain the original records that can establish the installation date of your unit. If you do not provide such documents, the start date of the term of this Limited Warranty will be based upon the date of unit manufacture, plus thirty (30) days. Failure to maintain the equipment through regular annual service maintenance by a qualified service technician shall void the warranty.

LIMITATIONS AND EXCLUSIONS

This document contains all warranties made by the Manufacturer and may not be varied, altered or extended by any person. There are no promises, or agreements extending from the Manufacture other than the statements contained herein. THIS WARRANTY IS IN LIEU OF ALL WARRANTIES EXPRESSED OR IMPLIED, TO THE EXTENT AUTHORIZED BY THE LAWS OF THE JURISDICTION, INCLUDING SPECIFICALLY THE WARRANTIES OR MERCHANTABILITY OF FITNESS FOR A PARTICULAR PURPOSE.

It is understood and agreed that the Manufacturer's obligation hereunder is limited to repairing or replacing parts determined to be defective as stated above. In no event shall the Manufacturer be responsible for any alleged personal injuries or other special, incidental or consequential damages. As to property damages, contract, tort or other claim the Manufacturer's responsibility shall not exceed the purchase price paid for the product.

All replacement parts will be warranted for the unused portion of the warranty coverage period remaining on the applicable unit.

Some Authorities do not allow certain warranty exclusions or limitations on duration of warranty or the exclusions or limitations of incidental or consequential damages. In such cases, the above limitations or exclusions may not apply to you and are not intended to do so where prohibited by law. This warranty gives you specific legal rights. You may also have other rights which vary by jurisdiction.

SCHWANK

**2 SCHWANK WAY, WAYNESBORO, GEORGIA. 30830
5285 BRADCO BLVD. MISSISSAUGA, ON, L4W 2A6**

Ph: 1-877-446-3727

Fax: 1-866-361-0523

www.SchwankUSA.com / www.Schwank.ca / www.InfraSave.com