

USER'S INFORMATION MANUAL

UPFLOW & DOWNFLOW/HORIZONTAL CONDENSING GAS FURNACES

**IMPORTANT: READ THESE INSTRUCTIONS THOROUGHLY BEFORE ATTEMPTING TO OPERATE THIS FURNACE.
KEEP THESE INSTRUCTIONS IN A SAFE PLACE FOR FUTURE REFERENCE.**



Recognize this symbol as an indication of Important Safety Information!

▲ WARNING

FIRE OR EXPLOSION HAZARD

Failure to follow safety warnings exactly could result in serious injury, death or property damage.

- Do not store or use gasoline or other flammable vapors and liquids in the vicinity of this or any other appliance.
- **WHAT TO DO IF YOU SMELL GAS**
 - Do not try to light any appliance.
 - Do not touch any electrical switch; do not use any phone in your building.
 - Leave the building immediately.
 - Immediately call your gas supplier from a neighbor's phone. Follow the gas supplier's instructions.
 - If you cannot reach your gas supplier, call the fire department.
 - Do not rely on smell alone to detect leaks. Due to various factors, you may not be able to smell fuel gases.
 - U.L. recognized fuel gas and CO detectors are recommended in all applications, and their installation should be in accordance with the manufacturer's recommendations and/or local laws, rules, regulations, or customs.
- **INSTALLATION AND SERVICE MUST BE PERFORMED BY A QUALIFIED INSTALLER, SERVICE AGENCY OR THE GAS SUPPLIER.**

SAFETY

This furnace has been designed to give you many years of efficient, dependable home comfort. With regular maintenance, this furnace will operate satisfactorily year after year. Please read this manual to familiarize yourself with operation, routine maintenance schedule, and safety procedures.



WARNING

- **IF THE INFORMATION IN THIS MANUAL IS NOT FOLLOWED EXACTLY, A FIRE OR EXPLOSION MAY RESULT, CAUSING PROPERTY DAMAGE, PERSONAL INJURY OR LOSS OF LIFE.**
- **IMPROPER INSTALLATION, ADJUSTMENT, ALTERATION, SERVICE OR MAINTENANCE CAN CAUSE PROPERTY DAMAGE, PERSONAL INJURY OR DEATH. FOR ASSISTANCE OR ADDITIONAL INFORMATION CONSULT A QUALIFIED INSTALLER, SERVICE AGENCY OR THE GAS SUPPLIER.**
- **PROPOSITION 65: THIS FURNACE CONTAINS FIBERGLASS INSULATION. RESPIRABLE PARTICLES OF FIBERGLASS ARE KNOWN TO THE STATE OF CALIFORNIA TO CAUSE CANCER. EXHAUST GAS FROM THIS FURNACE CONTAINS CHEMICALS, INCLUDING CARBON MONOXIDE, KNOWN TO THE STATE OF CALIFORNIA TO CAUSE BIRTH DEFECTS OR OTHER REPRODUCTIVE HARM.**

CAREFULLY FOLLOW THESE SAFETY RULES:

1. Combustible material must not be placed on or against the furnace jacket. The area around the furnace must be kept clear and free of all combustible materials including gasoline and other flammable vapors and liquids.
2. A furnace installed in an attic or other insulated space must be kept free and clear of insulating material. Examine the furnace area when installing the furnace or adding more insulation. Some materials may be combustible.
3. To prevent carbon monoxide poisoning, all blower doors and compartment covers must be replaced after the furnace is serviced. Do not operate the unit without all panels and doors securely in place.
4. Should overheating occur, or the gas valve fail to shut off the gas supply, turn off the manual gas valve to the furnace before turning off the electrical supply.
5. Any additions, changes or conversions required in order for the furnace to satisfactorily meet the application needs should be made by a qualified installer, service agency or the gas supplier, using factory specified or approved parts. Read your WARRANTY. Contact the WARRANTOR for conversion information. This furnace was equipped at the factory for use on NATURAL GAS ONLY. Conversion to L.P. GAS requires a special kit supplied by the WARRANTOR.
6. A furnace needs an adequate supply of combustion and ventilation air for proper and safe operation. Do not block or obstruct air openings on the furnace or air openings supplying the area where the furnace is installed. Do not store anything around the furnace that could block the flow of fresh air to the unit. Your installation may receive air from the inside heated space, from the outside, from the attic or crawl space. Whenever adding insulation, be sure the air supply openings are not covered.
7. Do not use this furnace if any part has been under water. Immediately call a qualified installer, service agency or the gas supplier to inspect the furnace and to replace any part of the control system and any gas control which has been under water.

▲ WARNING

CARBON MONOXIDE (CO) IS A COLORLESS, ODORLESS, POISONOUS GAS THAT CAN CAUSE SEVERE PERSONAL INJURY OR DEATH. CARBON MONOXIDE CAN BE PRODUCED BY ANY FUEL-BURNING DEVICE, INCLUDING BUT NOT LIMITED TO:

- MOTOR VEHICLES
- GENERATORS AND OTHER GASOLINE POWERED TOOLS AND ENGINES
- GAS AND FUEL-OIL APPLIANCES
- CHARCOAL OR GAS GRILLS
- WOOD OR GAS FIREPLACES AND STOVES
- OUTDOOR CAMPING EQUIPMENT

CARBON MONOXIDE FROM ANY ONE OF THESE DEVICES CAN BE INADVERTENTLY DRAWN INTO AND DISTRIBUTED THROUGH THE LIVING SPACE BY THE NORMAL OPERATION OF THE CENTRAL HEATING / AIR CONDITIONING SYSTEM (SEE FIGURE 1).

APPLIANCES AND FUEL BURNING DEVICES MUST BE INSTALLED, OPERATED AND MAINTAINED IN ACCORDANCE WITH THE MANUFACTURER'S INSTRUCTIONS.

GASOLINE-POWERED TOOLS AND MOTOR VEHICLES MUST NOT BE OPERATED IN ENCLOSED SPACES, SUCH AS BASEMENTS, CRAWL-SPACES, OR GARAGES, EVEN WITH DOORS AND WINDOWS OR VENTS OPEN, AS EXHAUST FUMES INCLUDING CARBON MONOXIDE CAN BUILD UP AND SEEP INTO THE LIVING SPACE THROUGH CRACKS AND OPENINGS IN THE STRUCTURE. TOXIC FUMES, INCLUDING CARBON MONOXIDE, CAN ALSO BE DRAWN INTO THE LIVING SPACE THROUGH OPENINGS AND SEAMS IN THE CENTRAL HEATING AND AIR CONDITIONING EQUIPMENT AND / OR DUCTWORK.

FOR THESE REASONS, THE U.S. CONSUMER PRODUCT SAFETY COMMISSION (CPSC) RECOMMENDS THAT EVERY HOME HAVE AT LEAST ONE CARBON MONOXIDE ALARM INSTALLED IN THE HALLWAY NEAR THE BEDROOMS IN EACH SEPARATE SLEEPING AREA OF THE HOME. CARBON MONOXIDE ALARMS SHOULD BE CERTIFIED TO THE REQUIREMENTS OF THE MOST RECENT UL, IAS OR CSA STANDARD, AND SHOULD BE INSTALLED, OPERATED AND MAINTAINED IN ACCORDANCE WITH THE ALARM MANUFACTURER'S INSTRUCTIONS.

GENERAL INFORMATION

IMPORTANT INFORMATION ABOUT FUEL GAS

This furnace has been manufactured to operate on natural gas. Your installer may have converted this furnace for operation on liquid propane (LP) gas depending on available fuel supply. Both LP Gas and natural gas have an odorant added to aid in detecting a gas leak. Some people may not be able to smell or recognize this odorant. If you are unsure or unfamiliar with the smell of LP gas or natural gas, ask your local gas supplier. Other conditions, such as "odor fade" which causes the odorant to diminish in intensity, can also make detecting a leak by smell more difficult.

The manufacturer recommends the use of U.L. recognized fuel gas detectors in all applications, installed in accordance with the detector instructions as an additional measure of security.

Natural gas is lighter than air and tends to rise, possibly accumulating in higher portions of the structure.

LP gas is heavier than air and tends to collect at lower levels, making it more difficult to detect or smell at nose level.

IMPORTANT INFORMATION ABOUT EFFICIENCY AND INDOOR AIR QUALITY

Central cooling and heating equipment is only as efficient as the duct system that carries the cooled or heated air. To maintain efficiency, comfort and good indoor air quality, it is important to have the proper balance between the air being supplied to each room and the air returning to the cooling and heating equipment.

Proper balance and sealing of the duct system improves the efficiency of the heating and air conditioning system and improves the indoor air quality of the home by reducing the amount of airborne pollutants that enter homes from spaces where the ductwork and / or equipment is located. The manufacturer and the U.S. Environmental Protection Agency's Energy Star Program recommend that central duct systems be checked by a qualified contractor for proper balance and sealing.

FIGURE 1
MIGRATION OF DANGEROUS SUBSTANCES, FUMES, AND ODORS INTO LIVING SPACES

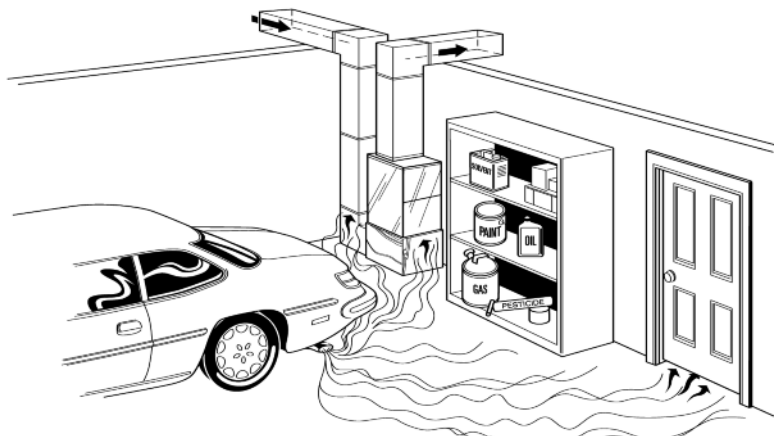

Adapted from Residential Duct Diagnostics and Repair, with permission of Air Conditioning Contractors of America (ACCA).

⚠ WARNING

DUCT LEAKS CAN CREATE AN UNBALANCED SYSTEM AND DRAW POLLUTANTS SUCH AS DIRT, DUST, FUMES AND ODORS INTO THE HOME CAUSING PROPERTY DAMAGE. FUMES AND ODORS FROM TOXIC, VOLATILE OR FLAMMABLE CHEMICALS, AS WELL AS AUTOMOBILE EXHAUST AND CARBON MONOXIDE (CO), CAN BE DRAWN INTO THE LIVING SPACE THROUGH LEAKING DUCTS AND UNBALANCED DUCT SYSTEMS CAUSING PERSONAL INJURY OR DEATH (SEE FIGURE 1).

- IF AIR-MOVING EQUIPMENT OR DUCTWORK IS LOCATED IN GARAGES OR OFF-GARAGE STORAGE AREAS - ALL JOINTS, SEAMS, AND OPENINGS IN THE EQUIPMENT AND DUCT MUST BE SEALED TO LIMIT THE MIGRATION OF TOXIC FUMES AND ODORS INCLUDING CARBON MONOXIDE FROM MIGRATING INTO THE LIVING SPACE.
- IF AIR-MOVING EQUIPMENT OR DUCTWORK IS LOCATED IN SPACES CONTAINING FUEL BURNING APPLIANCES SUCH AS WATER HEATERS OR BOILERS - ALL JOINTS, SEAMS, AND OPENINGS IN THE EQUIPMENT AND DUCT MUST ALSO BE SEALED TO PREVENT DEPRESSURIZATION OF THE SPACE AND POSSIBLE MIGRATION OF COMBUSTION BYPRODUCTS INCLUDING CARBON MONOXIDE INTO THE LIVING SPACE.

⚠ CAUTION

REGARDING EXTENDED ABSENCES/VACATION: This furnace has been equipped with multiple safety devices that protect you, your property and the furnace. If one or more of these safety devices activates, the operation of your furnace may stop until the condition is corrected, or the furnace is manually reset by a technician. If you intend to leave your home unoccupied for an extended period of time during winter months or freezing temperatures, it is recommended that you take precautions to prevent water pipes in your home from freezing, bursting and flooding your home due to a furnace stoppage.

SYSTEM OPERATION INFORMATION

1. Keep the air filters clean. Your heating system will operate more efficiently and provide better heating, more economically.
2. Arrange your furniture and drapes so that the supply air registers and the return air grilles are unobstructed.
3. Close doors and windows. This will reduce the heating load on your system.
4. Avoid excessive use of exhaust fans.
5. Do not permit the heat generated by television, lamps, or radios to influence the thermostat operation.
6. If you desire to operate your system with constant air circulation, consult your thermostat manual or please ask advice from a qualified installer, service agency or the gas supplier.

FIGURE 2
BURNER COMPARTMENT - SHOWING LOCATION OF GAS CONTROLS

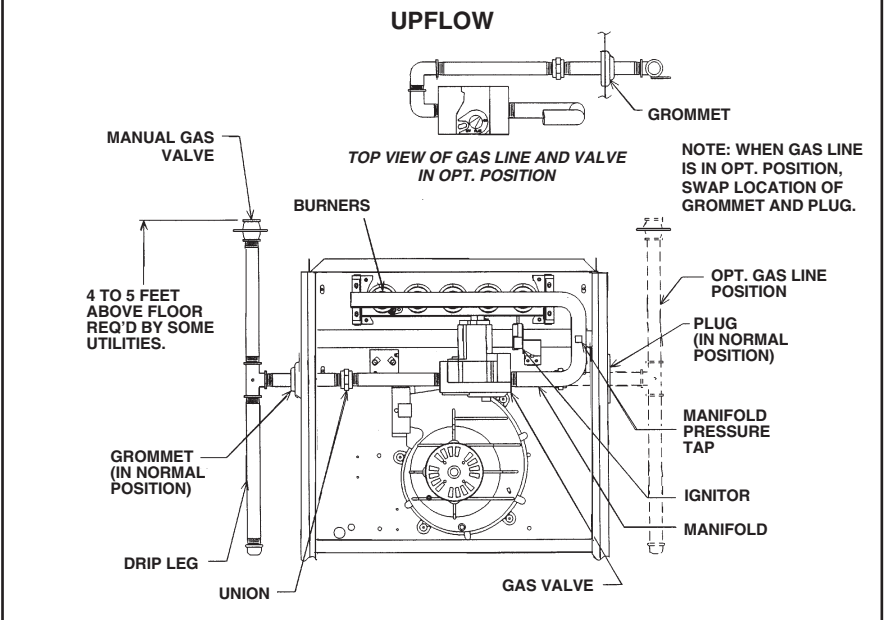
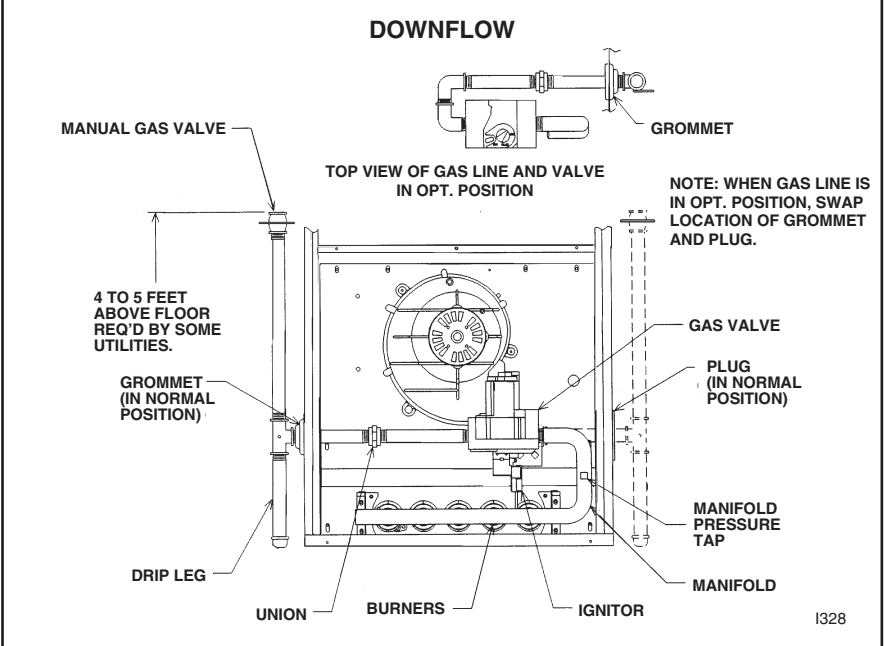

FIGURE 3
BURNER COMPARTMENT - SHOWING LOCATION OF GAS CONTROLS



SYSTEM OPERATION INFORMATION (continued)

The operation of the warm air furnace is automatic. Your qualified installer, service agency or the gas supplier has provided a wall mounted thermostat which is sensitive to the change in temperature of the air moving around the thermostat. Your thermostat will have switches to select some or all of the following functions:

HEAT - Turns heating on when temperature drops below the desired temperature.

COOL - Turns cooling on when temperature rises above the desired temperature.

AUTO - Turns cooling or heating system on as required to maintain the desired temperature.

OFF - Turns heating and cooling modes off. (The blower may still circulate air in the FAN-ON position.)

FAN-ON - Turns the blower on for continuous operation.

FAN-AUTO - The blower cycles on and off with cooling or heating operation.

FIGURE 4
BURNER COMPARTMENT - SHOWING LOCATION OF TYPICAL GAS CONTROLS - HORIZONTAL

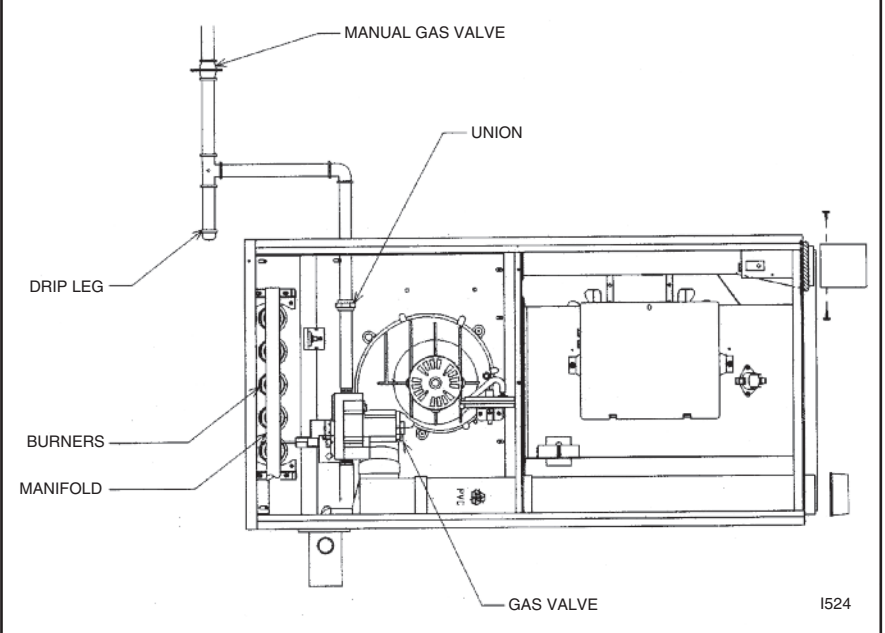
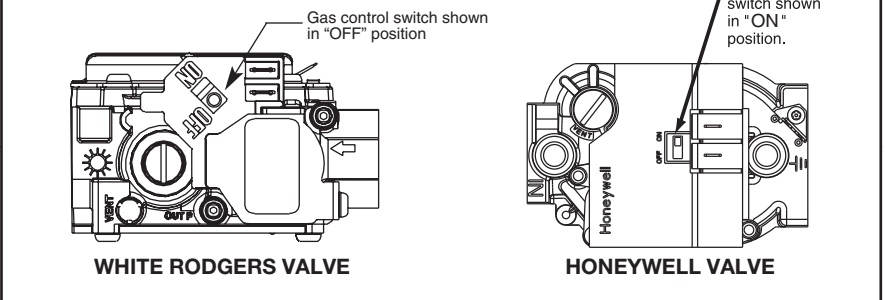

FIGURE 5
TYPICAL HOT SURFACE IGNITION GAS VALVE



FOR YOUR SAFETY READ BEFORE OPERATING

WARNING

IF YOU DO NOT FOLLOW THESE INSTRUCTIONS EXACTLY, A FIRE OR EXPLOSION MAY RESULT CAUSING PROPERTY DAMAGE, PERSONAL INJURY OR LOSS OF LIFE.

NOTE: Read and follow the Safety Information, Operating Instructions and instructions To Turn Off Gas To Appliance located on the furnace. This label will have specific information regarding the furnace and its gas controls.

OPERATING INSTRUCTIONS

1. STOP! Read all safety information.
2. Set the thermostat to the lowest setting.
3. Turn off all electric power to the appliance.
4. This appliance does not have a pilot. It is equipped with an ignition device which automatically lights the burner. Do not try to light the burner by hand.
5. Remove burner access door.
6. Turn manual gas control knob clockwise or set the gas control switch to the "OFF" position. See Figure 5.
7. Wait five (5) minutes to clear out any gas. If you then smell gas, STOP! If you don't smell gas, go to the next step.
8. Turn on gas to main burners by turning the manual gas control knob counterclockwise or set the gas control switch to the "ON" position.
9. Replace the burner access door. Be sure that attachment screws are tight.
10. Turn on all electric power to the appliance.
11. Set the thermostat to desired setting.
12. If the appliance will not operate, follow the instructions "To Turn Off Gas To The Appliance" and call your service technician or gas supplier.

TO TURN OFF GAS TO THE APPLIANCE

IMPORTANT: Shut off the manual gas valve located in the gas supply piping outside the furnace casing.

1. Set the thermostat to the lowest setting.
2. Turn off all electric power to the appliance if service is to be performed.
3. Remove the burner access door.
4. Turn the gas control knob or set the gas control switch to the "OFF" position. See Figure 5.
5. Replace burner access door.

MAINTENANCE

IT IS RECOMMENDED THAT AN ANNUAL INSPECTION OF YOUR FURNACE BE DONE BY A QUALIFIED INSTALLER, SERVICE AGENCY OR THE GAS SUPPLIER.

FILTER MAINTENANCE

Have your qualified installer, service agency or the gas supplier instruct you on how to access your filters for regular maintenance.

Keep air filters clean at all times. Vacuum dirt from filter, wash with detergent and water, air dry thoroughly and reinstall.

After filters are cleaned and returned to the furnace, be sure doors are properly reinstalled. If you are not totally sure of this procedure, consult a qualified installer, service agency or the gas supplier.

WARNING

DISCONNECT MAIN ELECTRICAL POWER TO THE UNIT BEFORE ATTEMPTING ANY MAINTENANCE. FAILURE TO DO SO CAN CAUSE ELECTRICAL SHOCK RESULTING IN SEVERE PERSONAL INJURY OR DEATH.

WARNING

TURN OFF ELECTRICAL POWER TO FURNACE BEFORE REMOVING FRONT ACCESS DOOR. FAILURE TO DO SO CAN RESULT IN ELECTRICAL SHOCK, SEVERE PERSONAL INJURY OR DEATH.

CAUTION

DO NOT OPERATE YOUR SYSTEM FOR EXTENDED PERIODS WITHOUT FILTERS. A PORTION OF THE DUST ENTRAINED IN THE AIR MAY TEMPORARILY LODGE IN THE AIR DUCT RUNS AND AT THE SUPPLY REGISTERS. ANY RECIRCULATED DUST PARTICLES WILL BE HEATED AND CHARRED BY CONTACT WITH THE FURNACE HEAT EXCHANGER. THIS RESIDUE WILL SOIL CEILINGS, WALLS, DRAPES, CARPETS, AND OTHER HOUSEHOLD ARTICLES.

REMOVING FILTERS

UPFLOW FURNACE - FILTER IN BOTTOM OR SIDE LOCATION

1. Remove the blower compartment access door.
2. Disengage the filter retaining rod and pull filter out.
3. Clean filter and reinstall.
4. Replace the blower compartment access door.

DOWNFLOW FURNACE - FILTERS IN TOP DUCT LOCATION

1. Remove the blower compartment access door.
2. Push up and in on the filters to disengage from retaining bracket and pull filters out.
3. Clean filter(s) and reinstall.
4. Replace the blower compartment access door.

FIGURE 6
UPFLOW SIDE FILTER LOCATION

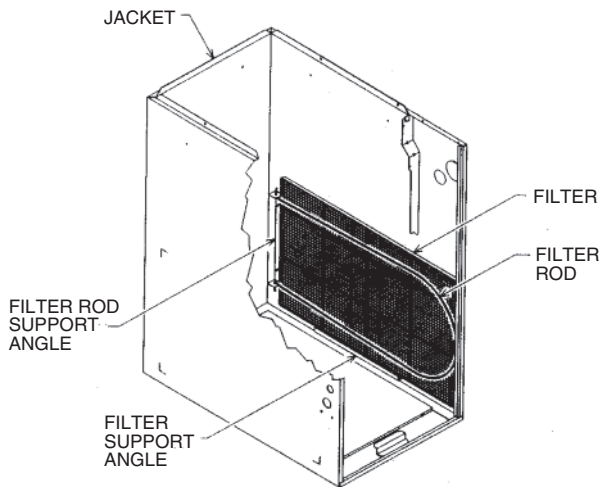

I332

FIGURE 7
UPFLOW BOTTOM FILTER INSTALLATION

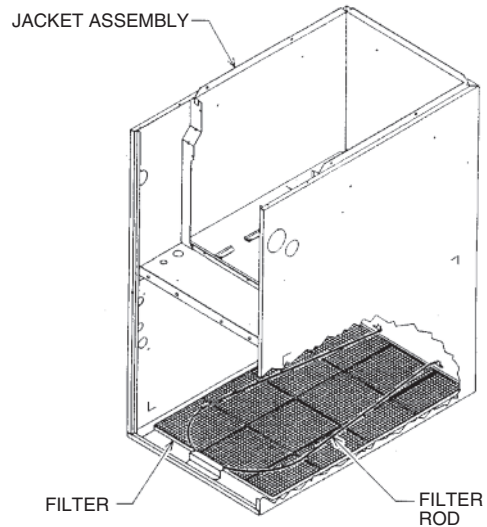

ADS-5422-01

UPFLOW FILTER SIZES

| FURNACE WIDTH | INPUT MBTUH | BOTTOM SIZE | SIDE SIZE | QUANTITY |
|---------------|-------------|-------------|------------|----------|
| 17½" | 45, 60, 75 | 15¾" X 25" | 15¾" X 25" | 1 |
| 21" | 90 AND 105 | 19¾" X 25" | 15¾" X 25" | 1 |
| 24½" | 120 | 22¾" x 25" | 15¾" x 25" | 1 |

| DOWNFLOW/HORIZONTAL FILTER SIZES | | | |
|----------------------------------|-------------|-----------|----------|
| FURNACE WIDTH | INPUT MBTUH | SIZE | QUANTITY |
| 17½" | 45, 60, 75 | 12" X 20" | 2 |
| 21" | 90, 105 | 12" X 20" | 2 |
| 24½" | 120 | 14" X 20" | 2 |

FIGURE 8
DOWNFLOW FILTERS LOCATION

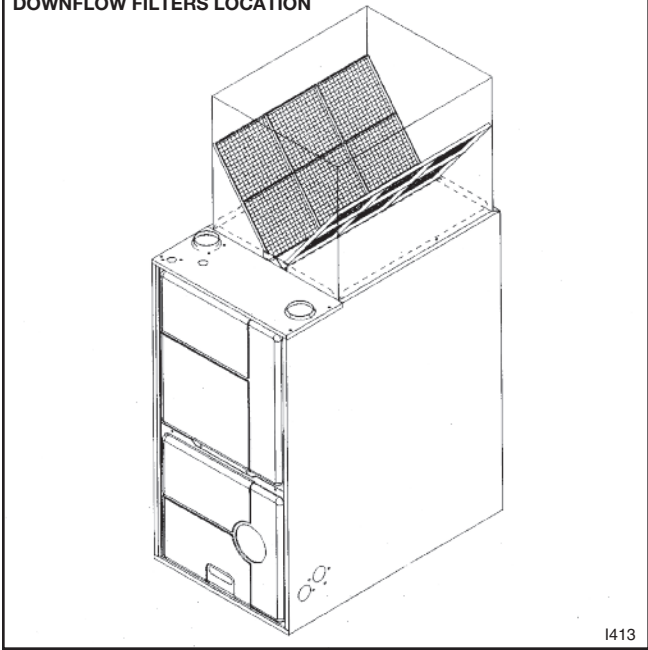
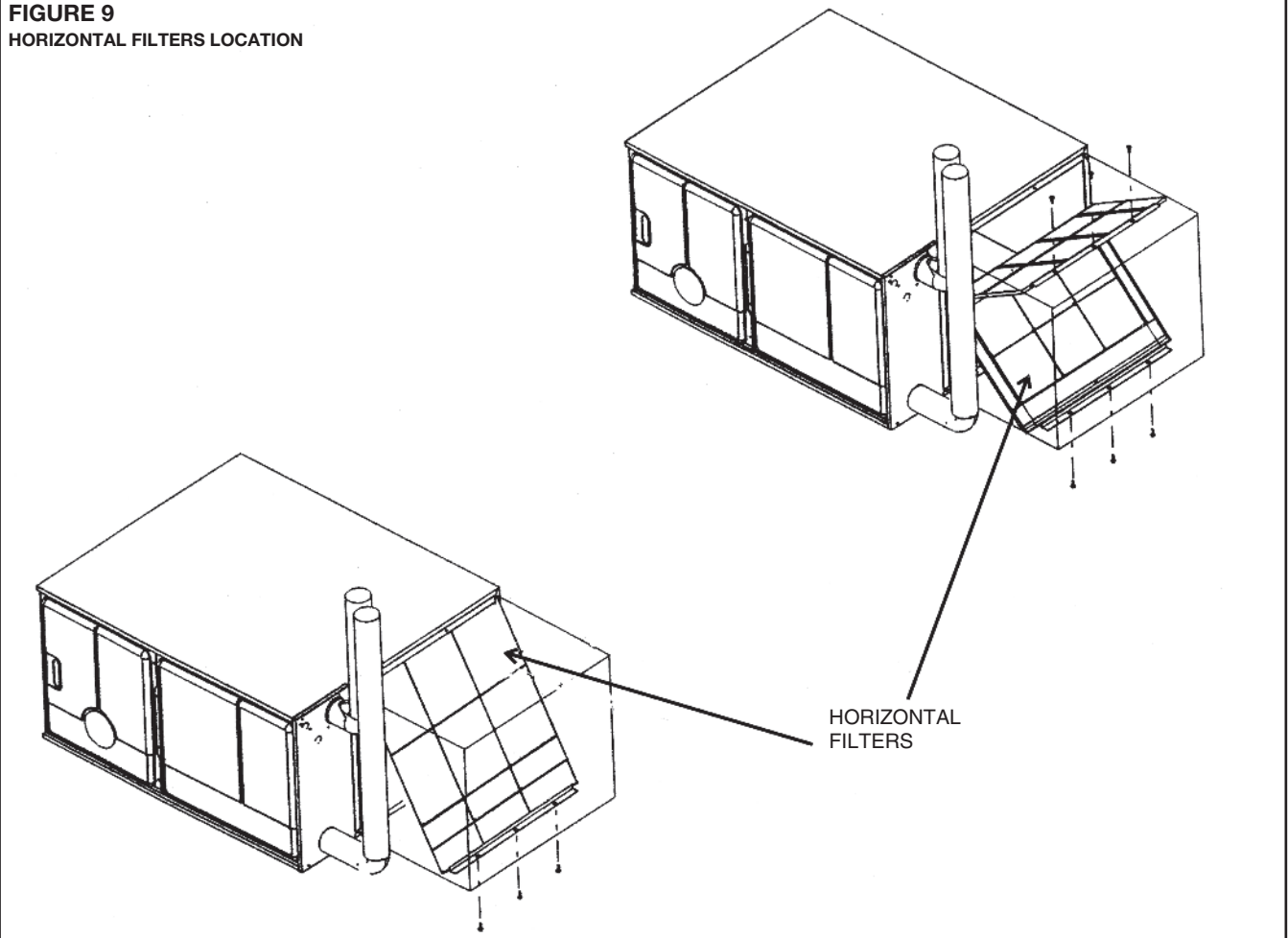

FIGURE 9
HORIZONTAL FILTERS LOCATION



WARNING

DISCONNECT MAIN ELECTRICAL POWER TO THE UNIT BEFORE ATTEMPTING ANY MAINTENANCE. FAILURE TO DO SO CAN RESULT IN ELECTRICAL SHOCK, SEVERE PERSONAL INJURY OR DEATH.

WARNING

IF DIRT, RUST, SOOT OR SCALE ACCUMULATIONS ARE PRESENT, DO NOT OPERATE THE FURNACE. INSPECT THE HEAT EXCHANGERS FOR LEAKS. LEAKS CAN CAUSE TOXIC FUMES TO ENTER THE HOME AND CAUSE CARBON MONOXIDE POISONING OR DEATH.

WARNING

CHECK VENT PIPE SECTIONS FOR DETERIORATION AND CHECK JOINT FITTINGS FOR THEIR INTEGRITY. IF IT HAS BECOME DISCONNECTED OR TOXIC FUMES CAN ESCAPE INTO THE HOME AND CAUSE CARBON MONOXIDE POISONING OR DEATH. DO NOT OPERATE THIS FURNACE. APPROPRIATE SERVICE MUST BE APPLIED.

ROUTINE MAINTENANCE

Routine maintenance to be provided by a qualified installer, service agency or the gas supplier **ONLY**.

IT IS RECOMMENDED THAT AN ANNUAL INSPECTION OF YOUR FURNACE BE DONE BY A QUALIFIED INSTALLER, SERVICE AGENCY OR THE GAS SUPPLIER.

LUBRICATION

The blower motor and induced draft motor are prelubricated by the manufacturer and do not require further attention.

IMPORTANT: DO NOT attempt to lubricate the bearings on the blower motor or the induced draft blower motor. Addition of lubricants can reduce the motor life and void the warranty.

The blower compartment and motor should be inspected and cleaned periodically by your qualified installer, service agency or the gas supplier to prevent the possibility of overheating due to an accumulation of dust and dirt on the windings or on the motor exterior. And, as suggested elsewhere in these instructions, the air filters should be kept clean because dirty filters can restrict airflow and the motor depends upon sufficient air flowing across and through it to keep from overheating.

COMBUSTION AREA AND VENT SYSTEM

1. It is recommended that an annual inspection of your furnace be done by a qualified installer, service agency or the gas supplier.
2. Turn OFF the electrical supply to the furnace and remove the access doors.
3. Inspect the gas burners for dirt, rust, or scale and clean as necessary.
4. Inspect the the flue connection area and vent pipe. Be sure that the vent connector is in place and slopes upward and is physically sound, without holes or excessive corrosion.
5. Be sure that the return air duct connections are physically sound, are sealed to the furnace casing and terminate outside the space containing the furnace.
6. Be sure the physical support of the furnace is sound, without sags, cracks, etc., around the base so as to provide a seal between the support and the base.
7. Look for obvious signs of deterioration of the furnace.
8. If the furnace is free of the above conditions, replace the access doors and restore electrical power to the furnace.
9. Start the furnace and observe its operation. Watch the burner flames to see if they are bright blue. If a suspected malfunction is observed, or the burner flames are not bright blue, apply appropriate service.

CONDENSATE

NOTE: This furnace is equipped with a pressure switch which will shut off the main burners if the condensate drain line becomes blocked.

Be sure this condensate drain line does not become blocked or plugged. Visual inspection of condensate flow can easily be made while the furnace is in operation. A flashlight can be used to illuminate the discharge end placed in the sewer openings.

Clean and flush the condensate tube to make sure condensate flows freely while the furnace is in operation.

If a means to neutralize the condensate has been provided for the furnace, be sure to follow the maintenance schedule furnished by the manufacturer.