

INSTALLATION INSTRUCTIONS

FOR RGFG UPFLOW HIGH EFFICIENCY MODULATING CONDENSING GAS FURNACES

RGFG

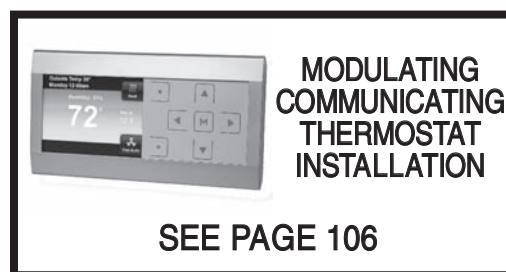
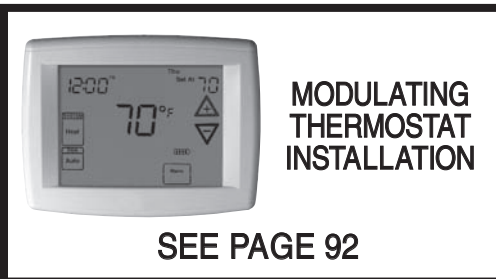

▲ WARNING

DO NOT EXCHANGE MEMORY CARDS BETWEEN 2 OR MORE DIFFERENT FURNACES. DOING SO COULD RESULT IN UNEXPECTED OPERATION – INCLUDING INADEQUATE AIRFLOW DURING HEATING (AND OTHER MODES) OR A LOSS OF HEAT.



▲ RECOGNIZE THIS SYMBOL AS AN INDICATION OF IMPORTANT SAFETY INFORMATION!

▲ WARNING

IF THE INFORMATION IN THESE INSTRUCTIONS IS NOT FOLLOWED EXACTLY, A FIRE OR EXPLOSION MAY RESULT, CAUSING PROPERTY DAMAGE, PERSONAL INJURY OR DEATH.

▲ WARNING

THESE INSTRUCTIONS ARE INTENDED AS AN AID TO QUALIFIED SERVICE PERSONNEL FOR PROPER INSTALLATION, ADJUSTMENT AND OPERATION OF THIS UNIT. READ THESE INSTRUCTIONS THOROUGHLY BEFORE ATTEMPTING INSTALLATION OR OPERATION. FAILURE TO FOLLOW THESE INSTRUCTIONS MAY RESULT IN IMPROPER INSTALLATION, ADJUSTMENT, SERVICE OR MAINTENANCE, POSSIBLY RESULTING IN FIRE, ELECTRICAL SHOCK, CARBON MONOXIDE POISONING, EXPLOSION, PROPERTY DAMAGE, PERSONAL INJURY OR DEATH.

▲ WARNING

PROPOSITION 65 WARNING: THIS PRODUCT CONTAINS CHEMICALS KNOWN TO THE STATE OF CALIFORNIA TO CAUSE CANCER, BIRTH DEFECTS OR OTHER REPRODUCTIVE HARM.

▲ WARNING

- Do not store or use gasoline or other flammable vapors and liquids, or other combustible materials in the vicinity of this or any other appliance.
- WHAT TO DO IF YOU SMELL GAS
 - Do not try to light any appliance.
 - Do not touch any electrical switch; do not use any phone in your building.
 - Immediately call your gas supplier from a neighbor's phone. Follow the gas supplier's instructions.
 - If you cannot reach your gas supplier, call the fire department.
- DO NOT RELY ON SMELL ALONE TO DETECT LEAKS. DUE TO VARIOUS FACTORS, YOU MAY NOT BE ABLE TO SMELL FUEL GASES.
 - U.L. recognized fuel gas and CO detectors are recommended in all applications, and their installation should be in accordance with the manufacturer's recommendations and/or local laws, rules regulations, or customs.
- Improper installation, adjustment, alteration, service or maintenance can cause injury, property damage or death. Refer to this manual. Installation and service must be performed by a qualified installer, service agency or the gas supplier. In the commonwealth of Massachusetts, installation must be performed by a licensed plumber or gas fitter for appropriate fuel.

DO NOT DESTROY THIS MANUAL. PLEASE READ CAREFULLY AND KEEP IN A SAFE PLACE FOR FUTURE REFERENCE BY A SERVICEMAN.

IMPORTANT: All Rheem products meet current Federal OSHA Guidelines for safety. California Proposition 65 warnings are required for certain products, which are not covered by the OSHA standards.

California's Proposition 65 requires warnings for products sold in California that contain, or produce, any of over 600 listed chemicals known to the State of California to cause cancer or birth defects such as fiberglass insulation, lead in brass, and combustion products from natural gas.

All "new equipment" shipped for sale in California will have labels stating that the product contains and/or produces Proposition 65 chemicals. Although we have not changed our processes, having the same label on all our products facilitates manufacturing and shipping. We cannot always know "when, or if" products will be sold in the California market.

You may receive inquiries from customers about chemicals found in, or produced by, some of our heating and air-conditioning equipment, or found in natural gas used with some of our products. Listed below are those chemicals and substances commonly associated with similar equipment in our industry and other manufacturers.

- Glass Wool (Fiberglass) Insulation
- Carbon Monoxide (CO)
- Formaldehyde
- Benzene

More details are available at the Websites for OSHA (Occupational Safety and Health Administration), at www.osha.gov and the State of California's OEHHA (Office of Environmental Health Hazard Assessment), at www.oehha.org. Consumer education is important since the chemicals and substances on the list are found in our daily lives. Most consumers are aware that products present safety and health risks, when improperly used, handled and maintained.

Installation Instructions are updated on a regular basis. This is done as product changes occur or if new information becomes available. In this publication, an arrow ► denotes changes from the previous edition or additional new material.

TABLE OF CONTENTS

SAFETY INFORMATION	3
INSTALLATION CHECK LIST	5
GENERAL INFORMATION	6
IMPORTANT INFORMATION ABOUT EFFICIENCY AND INDOOR AIR QUALITY	7
LOCATION REQUIREMENTS AND CONSIDERATIONS	8
CLEARANCE-ACCESSIBILITY	9
SITE SELECTION	9
DIMENSIONS AND CLEARANCE TO COMBUSTIBLES	10
DUCTING	11
VENTING AND COMBUSTION AIR PIPING	12
INSTALLATION WITH PRE-EXISTING VENT SYSTEMS	12
JOINING PIPE AND FITTINGS	12
CEMENTING JOINTS	13
NON-DIRECT VENT PIPE INSTALLATION	14
DIRECT VENT PIPE INSTALLATION	18
CONCENTRIC TERMINATIONS	20
CONDENSATE DRAIN / OPTIONAL NEUTRALIZER	28
GAS SUPPLY AND PIPING	30
GAS VALVE	31
LP CONVERSION	33
ELECTRICAL WIRING	35
ACCESSORIES	37
ELECTRONIC AIR CLEANER	37
HUMIDIFICATION AND DEHUMIDIFICATION	37
OTHER ACCESSORIES	39
TYPICAL WIRING ACCESSORIES FOR COMMUNICATING RESIDENTIAL SYSTEMS	39
HIGH ALTITUDE INSTALLATIONS IN THE U.S.	41
RGFG- HIGH ALTITUDE CONVERSION	41
LP GAS AT HIGH ALTITUDE ELEVATIONS	43
ZONING SYSTEMS	44
FURNACE INSTALLATION WITH NON-COMMUNICATING HIGH EFFICIENCY PREMIUM COOLING OR HEAT PUMP SYSTEMS	44
INTEGRATED FURNACE CONTROL	45
SEVEN SEGMENT DISPLAY	45
24 VAC THERMOSTAT INPUTS	47
SPECIAL CONFIGURATION – COMM T-STAT AND NON-COMM CONDENSER	47
MEMORY CARD	49
RULES FOR WRITING, DISTRIBUTION AND ARBITRATION OF MULTIPLE COPIES OF FURNACE SHARED DATA FOR COMMUNICATING-CAPABLE FURNACES	49
REPLACING THE FURNACE CONTROL	51
DIPSWITCHES	52
FURNACE OPERATION USING NON-COMMUNICATING MODULATING, MODULATING AND TWO-STAGE T-STATS	55
COMMUNICATING SYSTEMS	58
WIRING FOR COMMUNICATIONS	58
STARTUP FOR SYSTEMS CONFIGURED WITH COMMUNICATIONS	59
CONTINUOUS FAN OPERATION IN COMMUNICATING MODE	60
ACTIVE FAULT CODES WITH COMMUNICATING SYSTEMS	60
FURNACE USER MENUS	60
STATUS 1	61
STATUS 2	63
2 WK HIST	63
LIFE HIST	63
FAULT HISTORY	63
UNIT INFO	63
SETUP	63
DUAL-FUEL OPERATION	65
START-UP PROCEDURES	66
SEQUENCE OF OPERATION	68
SETTING INPUT RATE	68
MAINTENANCE	69
TROUBLESHOOTING CHART	72-73
NORMAL OPERATING CODES (TABLE 23)	74
FURNACE FAULT CODES WITH DESCRIPTIONS AND SOLUTIONS (TABLE 24)	75-90
WIRE DIAGRAM – STEPPER / SERVO MODULATING VALVE (FUEL CODES HA OR HB)	91
THERMOSTATS	92
NON-COMMUNICATING THERMOSTATS	92
THERMOSTAT WIRING (WITH WIRING DIAGRAMS)	93-95
APPLICATIONS	96
MODULATING, TOUCH-SCREEN, NON-COMMUNICATING THERMOSTAT ((-)HC-TST412MDMS)	96
COMMUNICATING THERMOSTATS	106
(-)HC-TST501CMMS PROGRAMMABLE COMMUNICATING THERMOSTAT	108
(-)HC-TST550CMMS FULL COLOR, PROGRAMMABLE COMMUNICATING THERMOSTAT	112
VIEWING FURNACE USER MENUS WITH THE (-)HC-TST550CMMS THERMOSTAT	113
CHANGING FURNACE SETUP ITEMS ON THE (-)HC-TST550CMMS THERMOSTAT	114

IMPORTANT: To insure proper installation and operation of this product, completely read all instructions prior to attempting to assemble, install, operate, maintain or repair this product. Upon unpacking of the furnace, inspect all parts for damage prior to installation and start-up.

SAFETY INFORMATION

IMPORTANT!

THE COMMONWEALTH OF MASSACHUSETTS REQUIRES COMPLIANCE WITH REGULATION 248 CMR 4.00 AND 5.00 FOR INSTALLATION OF THROUGH-THE-WALL VENTED GAS APPLIANCES AS FOLLOWS:

(a) For all side wall horizontally vented gas fueled equipment installed in every dwelling, building or structure used in whole or in part for residential purposes, including those owned or operated by the Commonwealth and where the side wall exhaust vent termination is less than seven (7) feet above finished grade in the area of the venting, including but not limited to decks and porches, the following requirements shall be satisfied:

1. INSTALLATION OF CARBON MONOXIDE DETECTORS. At the time of installation of the side wall horizontal vented gas fueled equipment, the installing plumber or gasfitter shall observe that a hard wired carbon monoxide detector with an alarm and battery back-up is installed on the floor level where the gas equipment is to be installed. In addition, the installing plumber or gasfitter shall observe that a battery operated or hard wired carbon monoxide detector with an alarm is installed on each additional level of the dwelling, building or structure served by the side wall horizontal vented gas fueled equipment. It shall be the responsibility of the property owner to secure the services of qualified licensed professionals for the installation of hard wired carbon monoxide detectors.

a. In the event that the side wall horizontally vented gas fueled equipment is installed in a crawl space or an attic, the hard wired carbon monoxide detector with alarm and battery back-up may be installed on the next adjacent floor level.

b. In the event that the requirements of this subdivision can not be met at the time of completion of installation, the owner shall have a period of thirty (30) days to comply with the above requirements; provided, however, that during said thirty (30) day period, a battery operated carbon monoxide detector with an alarm shall be installed.

2. APPROVED CARBON MONOXIDE DETECTORS. Each carbon monoxide detector as required in accordance with the above provisions shall comply with NFPA 720 and be ANSI/UL 2034 listed and IAS certified.

3. SIGNAGE. A metal or plastic identification plate shall be permanently mounted to the exterior of the building at a minimum height of eight (8) feet above grade directly in line with the exhaust vent terminal for the horizontally vented gas fueled heating appliance or equipment. The sign shall read, in print size no less than one-half (1/2) inch in size, **“GAS VENT DIRECTLY BELOW. KEEP CLEAR OF ALL OBSTRUCTIONS”**.

4. INSPECTION. The state or local gas inspector of the side wall horizontally vented gas fueled equipment shall not approve the installation unless, upon inspection, the inspector observes carbon monoxide detectors and signage installed in accordance with the provisions of 248 CMR 5.08(2)(a) 1 through 4.

(b) **EXEMPTIONS:** The following equipment is exempt from 248 CMR 5.08(2)(a)1 through 4:

1. The equipment listed in Chapter 10 entitled “Equipment Not Required To Be Vented” in the most current edition of NFPA 54 as adopted by the Board; and

2. Product Approved side wall horizontally vented gas fueled equipment installed in a room or structure separate from the dwelling, building or structure used in whole or in part for residential purposes.

(c) **MANUFACTURER REQUIREMENTS – GAS EQUIPMENT VENTING SYSTEM PROVIDED.** When the manufacturer of Product Approved side wall horizontally vented gas equipment provides a venting system design or venting system components with the equipment, the instructions provided by the manufacturer for installation of the equipment and the venting system shall include:

1. Detailed instructions for the installation of the venting system design or the venting system components; and

2. A complete parts list for the venting system design or venting system.

(d) **MANUFACTURER REQUIREMENTS – GAS EQUIPMENT VENTING SYSTEM NOT PROVIDED.** When the manufacturer of a Product Approved side wall horizontally vented gas fueled equipment does not provide the parts for venting the flue gases, but identifies “special venting systems”, the following requirements shall be satisfied by the manufacturer:

1. The referenced “special venting system” instructions shall be included with the appliance or equipment installation instructions; and

2. The “special venting systems” shall be Product Approved by the Board, and the instructions for that system shall include a parts list and detailed installation instructions.

(e) A copy of all installation instructions for all Product Approved side wall horizontally vented gas fueled equipment, all venting instructions, all parts lists for venting instructions, and/or all venting design instructions shall remain with the appliance or equipment at the completion of the installation.

▲ WARNING

INSTALL THIS FURNACE ONLY IN A LOCATION AND POSITION AS SPECIFIED IN THE LOCATION REQUIREMENTS AND CONSIDERATIONS SECTION OF THESE INSTRUCTIONS. PROVIDE ADEQUATE COMBUSTION AND VENTILATION AIR TO THE FURNACE SPACE AS SPECIFIED IN THE VENTING SECTION OF THESE INSTRUCTIONS.

▲ WARNING

PROVIDE ADEQUATE COMBUSTION AND VENTILATION AIR TO THE FURNACE SPACE AS SPECIFIED IN THE COMBUSTION AND VENTILATION AIR SECTION OF THESE INSTRUCTIONS.

▲ WARNING

COMBUSTION PRODUCTS MUST BE DISCHARGED OUTDOORS. CONNECT THIS FURNACE TO AN APPROVED VENT SYSTEM ONLY, AS SPECIFIED IN VENT PIPE INSTALLATION SECTION OF THESE INSTRUCTIONS.

▲ WARNING

NEVER TEST FOR GAS LEAKS WITH AN OPEN FLAME. USE A COMMERCIALY AVAILABLE SOAP SOLUTION MADE SPECIFICALLY FOR THE DETECTION OF LEAKS TO CHECK ALL CONNECTIONS, AS SPECIFIED IN GAS SUPPLY AND PIPING SECTION OF THESE TION INSTRUCTIONS.

▲ WARNING

THIS FURNACE IS NOT APPROVED OR RECOMMENDED FOR INSTALLATION ON ITS BACK, WITH ACCESS DOORS FACING UPWARDS, OR WITH SUPPLY AIR DISCHARGING TO THE RIGHT-HAND SIDE WHEN FACING THE FRONT OF THE FURNACE. SEE FIGURE 3 FOR PROPER INSTALLATION OF HORIZONTAL MODELS.

▲ WARNING

DO NOT INSTALL THIS FURNACE IN A MOBILE HOME!! THIS FURNACE IS NOT APPROVED FOR INSTALLATION IN A MOBILE HOME. DOING SO COULD CAUSE FIRE, PROPERTY DAMAGE, PERSONAL INJURY OR DEATH.

▲ WARNING

USE ONLY WITH TYPE OF GAS APPROVED FOR THIS FURNACE. REFER TO THE FURNACE RATING PLATE.

▲ WARNING

WHEN THIS FURNACE IS INSTALLED IN A RESIDENTIAL GARAGE, IT MUST BE INSTALLED SO THE BURNERS AND IGNITION SOURCE ARE LOCATED NO LESS THAN 18 INCHES ABOVE THE FLOOR. THIS IS TO REDUCE THE RISK OF IGNITING FLAMMABLE VAPORS WHICH MAY BE PRESENT IN A GARAGE. ALSO, THE FURNACE MUST BE LOCATED OR PROTECTED TO AVOID PHYSICAL DAMAGE BY VEHICLES. FAILURE TO FOLLOW THESE WARNINGS CAN CAUSE A FIRE OR EXPLOSION, RESULTING IN PROPERTY DAMAGE, PERSONAL INJURY OR DEATH.

▲ WARNING

USE OF THIS FURNACE IS ALLOWED DURING CONSTRUCTION IF THE FOLLOWING TEMPORARY INSTALLATION REQUIREMENTS ARE MET. INSTALLATION MUST COMPLY WITH ALL INSTALLATION INSTRUCTIONS INCLUDING:

- PROPER VENT INSTALLATION;
- FURNACE OPERATING UNDER THERMOSTATIC CONTROL;
- RETURN AIR DUCT SEALED TO THE FURNACE;
- AIR FILTERS IN PLACE;
- SET FURNACE INPUT RATE AND TEMPERATURE RISE PER RATING PLATE MARKING;
- MEANS FOR PROVIDING OUTDOOR AIR REQUIRED FOR COMBUSTION;
- RETURN AIR TEMPERATURE MAINTAINED BETWEEN 55°F (13°C) AND 80°F (27°C); AND;
- CLEAN FURNACE, DUCT WORK AND COMPONENTS UPON SUBSTANTIAL COMPLETION OF THE CONSTRUCTION PROCESS, AND VERIFY FURNACE OPERATING CONDITIONS INCLUDING IGNITION, INPUT RATE, TEMPERATURE RISE AND VENTING, ACCORDING TO THE INSTRUCTIONS.

▲ WARNING

DO NOT JUMPER OR OTHERWISE BYPASS OVERTEMPERATURE OR ANY OTHER LIMITS OR SWITCHES ON THE FURNACE. IF ONE OF THESE LIMITS OR SWITCHES SHOULD TRIP OR OPEN, THE USER IS TO BE INSTRUCTED TO CALL A QUALIFIED INSTALLER, SERVICE AGENCY OR THE GAS SUPPLIER. FOR MANUALLY RESETTABLE SWITCHES, THE USER IS FURTHER INSTRUCTED TO NEVER RESET THE SWITCH, BUT TO CALL A QUALIFIED TECHNICIAN. MANUAL RESET SWITCHES MAY REQUIRE FURTHER CORRECTIVE ACTIONS. FAILURE TO FOLLOW THIS WARNING COULD RESULT IN CARBON MONOXIDE POISONING, SERIOUS INJURY OR DEATH. IF THE UNIT IS INSTALLED IN A CLOSET, THE DOOR MUST BE CLOSED WHEN MAKING THIS CHECK. INSTALLERS AND TECHNICIANS ARE INSTRUCTED TO REPLACE ANY LIMIT OR SAFETY SWITCH/DEVICE ONLY WITH IDENTICAL REPLACEMENT PARTS.

▲ WARNING

DUCT LEAKS CAN CREATE AN UNBALANCED SYSTEM AND DRAW POLLUTANTS SUCH AS DIRT, DUST, FUMES AND ODORS INTO THE HOME CAUSING PROPERTY DAMAGE. FUMES AND ODORS FROM TOXIC, VOLATILE OR FLAMMABLE CHEMICALS, AS WELL AS AUTOMOBILE EXHAUST AND CARBON MONOXIDE (CO), CAN BE DRAWN INTO THE LIVING SPACE THROUGH LEAKING DUCTS AND UNBALANCED DUCT SYSTEMS CAUSING PERSONAL INJURY OR DEATH.

- IF AIR-MOVING EQUIPMENT OR DUCTWORK IS LOCATED IN GARAGES OR OFF-GARAGE STORAGE AREAS - ALL JOINTS, SEAMS, AND OPENINGS IN THE EQUIPMENT AND DUCT MUST BE SEALED TO LIMIT THE MIGRATION OF TOXIC FUMES AND ODORS INCLUDING CARBON MONOXIDE FROM MIGRATING INTO THE LIVING SPACE.
- IF AIR-MOVING EQUIPMENT OR DUCTWORK IS LOCATED IN SPACES CONTAINING FUEL BURNING APPLIANCES SUCH AS WATER HEATERS OR BOILERS - ALL JOINTS, SEAMS, AND OPENINGS IN THE EQUIPMENT AND DUCT MUST ALSO BE SEALED TO PREVENT DEPRESSURIZATION OF THE SPACE AND POSSIBLE MIGRATION OF COMBUSTION BYPRODUCTS INCLUDING CARBON MONOXIDE INTO THE LIVING SPACE.

▲ WARNING

ALWAYS INSTALL FURNACE TO OPERATE WITHIN THE FURNACE'S INTENDED TEMPERATURE-RISE RANGE WITH A DUCT SYSTEM WHICH HAS AN EXTERNAL STATIC PRESSURE WITHIN THE ALLOWABLE RANGE, AS SPECIFIED IN DUCTING SECTION OF THESE INSTRUCTIONS. SEE ALSO FURNACE RATING PLATE.

▲ WARNING

WHEN A FURNACE IS INSTALLED SO THAT SUPPLY DUCTS CARRY AIR CIRCULATED BY THE FURNACE TO AREAS OUTSIDE THE SPACE CONTAINING THE FURNACE, THE RETURN AIR SHALL ALSO BE HANDLED BY DUCT(S) SEALED TO THE FURNACE CASING AND TERMINATING OUTSIDE THE SPACE CONTAINING THE FURNACE.

NOTICE

IMPROPER INSTALLATION, OR INSTALLATION NOT MADE IN ACCORDANCE WITH THE CSA INTERNATIONAL (CSA) CERTIFICATION OR THESE INSTRUCTIONS, CAN RESULT IN UNSATISFACTORY OPERATION AND/OR DANGEROUS CONDITIONS AND ARE NOT COVERED BY THE UNIT WARRANTY.

NOTICE

IN COMPLIANCE WITH RECOGNIZED CODES, IT IS RECOMMENDED THAT AN AUXILIARY DRAIN PAN BE INSTALLED UNDER ALL EVAPORATOR COILS OR UNITS CONTAINING EVAPORATOR COILS THAT ARE LOCATED IN ANY AREA OF A STRUCTURE WHERE DAMAGE TO THE BUILDING OR BUILDING CONTENTS MAY OCCUR AS A RESULT OF AN OVERFLOW OF THE COIL DRAIN PAN OR A STOPPAGE IN THE PRIMARY CONDENSATE DRAIN PIPING. SEE ACCESSORIES SECTION OF THESE INSTRUCTIONS FOR AUXILIARY HORIZONTAL OVERFLOW PAN INFORMATION (MODEL RXBM).

▲ WARNING

DO NOT EXCHANGE MEMORY CARDS BETWEEN 2 OR MORE DIFFERENT FURNACES. DOING SO COULD RESULT IN UNEXPECTED OPERATION - INCLUDING INADEQUATE AIRFLOW DURING HEATING (AND OTHER MODES OR A LOSS OF HEAT).

INSTALLATION CHECK LIST

REFER TO INSTALLATION INSTRUCTIONS

GAS SUPPLY

- _____ Adequate pipe size
- _____ Correct supply pressure (during furnace operation)
- _____ Manifold pressure
- _____ No gas leaks

ELECTRICAL

- _____ 115 V.A.C. supply (Single Circuit)
- _____ Polarity observed
- _____ Furnace properly grounded (Earth ground)
- _____ Adequate wire size

FURNACE INSTALLATION

- _____ Adequate clearance to combustibles
- _____ Adequate clearance for service (at front)

DUCT STATIC PRESSURE

- _____ in. w.c. on heating speed
- _____ in. w.c. on cooling speed
- _____ Air temperature rise

CONDENSATE LINE

- _____ Trap filled with water
- _____ Vented
- _____ Sloped toward drain
- _____ Condensate drain line hoses connected and clamped
- _____ Freeze protection (if necessary)
- _____ Neutralizer (if needed)

VENTING – DIRECT VENT

- _____ in. diameter – intake pipe
- _____ in. diameter – exhaust pipe
- _____ ft. of pipe – intake air
- _____ no. of elbows – intake air
- _____ ft. of pipe – exhaust pipe
- _____ no. of elbows – exhaust pipe

TERMINATIONS – DIRECT VENT

VERTICAL

- _____ Intake – 12" min. above roof/snow level
- _____ Correct relationship – exhaust to intake

VERTICAL – CONCENTRIC (RXGY-E03A)

- _____ Intake – 12" min. above roof/snow level

HORIZONTAL – STANDARD (RXGY-D02, -D02A, -D03, -D03A)

- _____ Correct relationship – exhaust to intake
- _____ 12" min. above grade/snow level

HORIZONTAL – ALTERNATE (RXGY-D02, -D02A, -D03, -D03A, -D04 OR -D04A)

- _____ Correct relationship – exhaust to intake
- _____ Above anticipated snow level

HORIZONTAL – CONCENTRIC (RXGY-E03A)

- _____ 12" min. above grade/snow level
- _____ Intake “Y” rotated above center
- _____ Exhaust sloped toward furnace

VENTING – NON-DIRECT VENT (VERTICAL ONLY)

- _____ in. diameter – exhaust pipe
- _____ ft. of pipe – exhaust
- _____ no. of elbows

TERMINATION – NON-DIRECT VENT (VERTICAL ONLY)

- _____ 12" min. above roof/snow level
- _____ Model #
- _____ Serial #
- _____ Date of installation

GENERAL INFORMATION

The RGFG series furnaces are design-certified by CSA for use with natural and L.P. gases as follows:

- As direct vent, central forced air furnaces with all combustion air supplied directly to the furnace burners through a special air intake system outlined in these instructions.
- As non-direct, central forced air furnace taking combustion air from the installation area or using air ducted from the outside.
- **IMPORTANT:** Proper application, installation and maintenance of this

furnace are required if consumers are to receive the full benefits for which they have paid.

Install this furnace in accordance with the American National Standard Z223.1 – latest edition entitled “National Fuel Gas Code” (NFPA54, 90A and 90B) and requirements or codes of the local utilities or other authorities having jurisdiction. This is available from the following:

National Fire Protection Association, Inc.
 Batterymarch Park
 Quincy, MA 02269

CSA International - U.S.
 8501 East Pleasant Valley Road
 Cleveland, Ohio, 44131

Canadian installations must be installed in accordance with CSA, local installation codes and authorities having jurisdiction. CSA is available from:

CSA International - Canada
 178 Rexdale Blvd.
 Etobicoke (Toronto), Ontario,
 Canada M9W-1R3

FIGURE 1
UPFLOW FURNACE RGFG
(GAS VALVE MAY BE DIFFERENT THAN SHOWN)

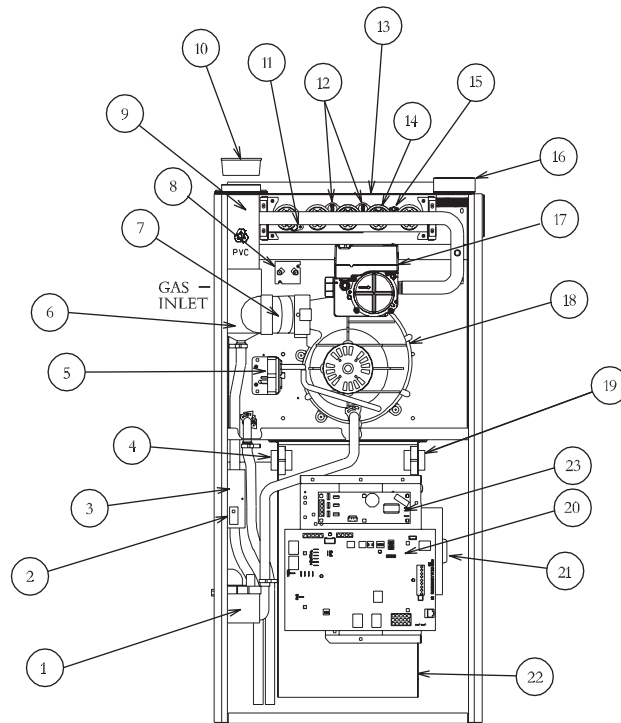

ITEM NO.	PART NAME	ITEM NO.	PART NAME
1	CONDENSATE TRAP	13	TOP PLATE
2	DOOR SWITCH	14	BURNER
3	JUNCTION BOX	15	IGNITER
4	TRANSFORMER	16	COMBUSTION AIR INLET
5	PRESSURE SWITCH ASSEMBLY	17	GAS VALVE
6	EXHAUST TRANSITION	18	INDUCED DRAFT BLOWER
7	CONNECTOR	19	POWER FACTOR CHOKE
8	MAIN LIMIT	20	INTEGRATED FURNACE CONTROL
9	EXHAUST AIR PIPE	21	BLOWER MOTOR
10	VENT CAP SHIPPING PLUG	22	BLOWER HOUSING
11	FLAME SENSOR	23	INDUCER CONTROL MODULE
12	OVERTEMPERATURE SWITCH		

ST-A1156-01

IMPORTANT INFORMATION ABOUT EFFICIENCY AND INDOOR AIR QUALITY

Central cooling and heating equipment is only as efficient as the duct system that carries the cooled or heated air. To maintain efficiency, comfort and good indoor air quality, it is important to have the proper balance between the air being supplied to each room and the air returning to the cooling and heating equipment.

Proper balance and sealing of the duct system improves the efficiency of the heating and air conditioning system and improves the indoor air quality of the home by reducing the amount of airborne pollutants that enter homes from spaces where the ductwork and / or equipment is located. The manufacturer and the U.S. Environmental Protection Agency's Energy Star Program recommend that central duct systems be checked by a qualified contractor for proper balance and sealing.

▲ WARNING

DUCT LEAKS CAN CREATE AN UNBALANCED SYSTEM AND DRAW POLLUTANTS SUCH AS DIRT, DUST, FUMES AND ODORS INTO THE HOME CAUSING PROPERTY DAMAGE. FUMES AND ODORS FROM TOXIC, VOLATILE OR FLAMMABLE CHEMICALS, AS WELL AS AUTOMOBILE EXHAUST AND CARBON MONOXIDE (CO), CAN BE DRAWN INTO THE LIVING SPACE THROUGH LEAKING DUCTS AND UNBALANCED DUCT SYSTEMS CAUSING PERSONAL INJURY OR DEATH (SEE FIGURE 2).

- IF AIR-MOVING EQUIPMENT OR DUCTWORK IS LOCATED IN GARAGES OR OFF-GARAGE STORAGE AREAS - ALL JOINTS, SEAMS, AND OPENINGS IN THE EQUIPMENT AND DUCT MUST BE SEALED TO LIMIT THE MIGRATION OF TOXIC FUMES AND ODORS INCLUDING CARBON MONOXIDE FROM MIGRATING INTO THE LIVING SPACE.
- IF AIR-MOVING EQUIPMENT OR DUCTWORK IS LOCATED IN SPACES CONTAINING FUEL BURNING APPLIANCES SUCH AS WATER HEATERS OR BOILERS - ALL JOINTS, SEAMS, AND OPENINGS IN THE EQUIPMENT AND DUCT MUST ALSO BE SEALED TO PREVENT DEPRESSURIZATION OF THE SPACE AND POSSIBLE MIGRATION OF COMBUSTION BYPRODUCTS INCLUDING CARBON MONOXIDE INTO THE LIVING SPACE.

NOTICE

IMPROPER INSTALLATION, OR INSTALLATION NOT MADE IN ACCORDANCE WITH THE CSA INTERNATIONAL (CSA) CERTIFICATION OR THESE INSTRUCTIONS, CAN RESULT IN UNSATISFACTORY OPERATION AND/OR DANGEROUS CONDITIONS AND ARE NOT COVERED BY THE UNIT WARRANTY.

NOTICE

IN COMPLIANCE WITH RECOGNIZED CODES, IT IS RECOMMENDED THAT AN AUXILIARY DRAIN PAN BE INSTALLED UNDER ALL EVAPORATOR COILS OR UNITS CONTAINING EVAPORATOR COILS THAT ARE LOCATED IN ANY AREA OF A STRUCTURE WHERE DAMAGE TO THE BUILDING OR BUILDING CONTENTS MAY OCCUR AS A RESULT OF AN OVERFLOW OF THE COIL DRAIN PAN OR A STOPPAGE IN THE PRIMARY CONDENSATE DRAIN PIPING. SEE ACCESSORIES SECTION OF THESE INSTRUCTIONS FOR AUXILIARY HORIZONTAL OVERFLOW PAN INFORMATION (MODEL RXBM).

matches what is required for the job specification.

- Read the entire instructions before starting the installation.
- Some building codes require extra cabinet insulation and gasketing when unit is installed in attic applications.
- If installed in an unconditioned space, apply caulking around the power wires, control wires, refrigerant tubing and condensate line where they enter the cabinet. Seal the power wires on the inside where they exit conduit opening. Caulking is required to prevent air leakage into and condensate from forming inside the unit, control box, and on electrical controls.
- Install the unit in such a way as to allow necessary access to the coil/filter rack and blower/control compartment.
- Install the unit in a level position to ensure proper condensate drainage. Make sure unit is level in both directions within 1/8".
- Install the unit in accordance with any local code which may apply and the national codes. Latest edi-

FIGURE 2
MIGRATION OF DANGEROUS SUBSTANCES, FUMES, AND ODORS INTO LIVING SPACES

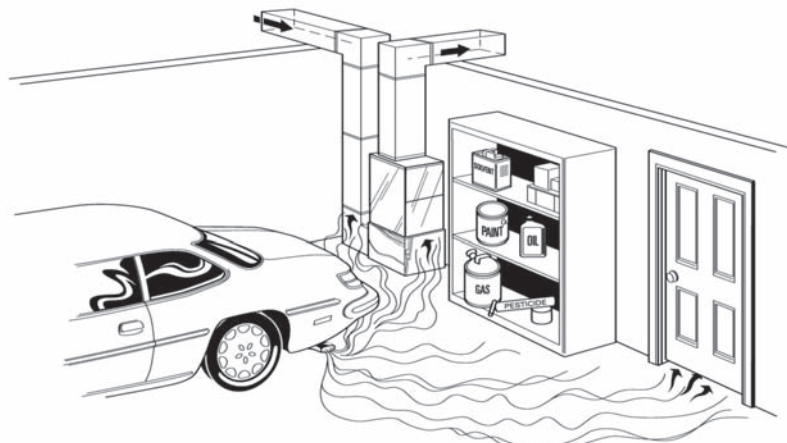

Adapted from *Residential Duct Diagnostics and Repair*, with permission of Air Conditioning Contractors of America (ACCA).

RECEIVING

Immediately upon receipt, all cartons and contents should be inspected for transit damage. Units with damaged cartons should be opened immediately. If damage is found, it should be noted on the delivery papers, and a damage claim filed with the last carrier.

- After unit has been delivered to job site, remove carton taking care not to damage unit.
- Check the unit rating plate for unit size, electric heat, coil, voltage, phase, etc. to be sure equipment

are available from: "National Fire Protection Association, Inc., Batterymarch Park, Quincy, MA 02269." These publications are:

- ANSI/NFPA No. 70-(Latest Edition) National Electrical Code.
- NFPA90A Installation of Air Conditioning and Ventilating Systems.
- NFPA90B Installation of warm air heating and air conditioning systems.
- The equipment has been evaluated in accordance with the Code of Federal Regulations, Chapter XX, Part 3280.

LOCATION REQUIREMENTS AND CONSIDERATIONS

GENERAL INFORMATION

▲ CAUTION

DO NOT USE THIS FURNACE DURING CONSTRUCTION IF AIR LADEN CORROSIVE COMPOUNDS ARE PRESENT SUCH AS CHLORINE AND FLUORINE. OTHERWISE, PROVISIONS MUST BE TAKEN TO PROVIDE CLEAN, UNCONTAMINATED COMBUSTION AND VENTILATION AIR TO THE FURNACE. FURNACE COMBUSTION AND VENTILATION AIR CONTAMINATED WITH THESE COMPOUNDS FORMS ACIDS DURING COMBUSTION WHICH CORRODES THE HEAT EXCHANGER AND COMPONENT PARTS. SOME OF THESE CONTAMINANTS ARE FOUND IN, BUT NOT LIMITED TO, PANELING, DRY WALL, ADHESIVES, PAINTS, STAINS, VARNISHES, SEALERS, AND MASONRY CLEANING MATERIALS.

▲ WARNING

DO NOT INSTALL THIS FURNACE IN A MOBILE HOME!! THIS FURNACE IS NOT APPROVED FOR INSTALLATION IN A MOBILE HOME. DOING SO COULD CAUSE FIRE, PROPERTY DAMAGE, PERSONAL INJURY OR DEATH.

▲ WARNING

WHEN THIS FURNACE IS INSTALLED IN A RESIDENTIAL GARAGE, IT MUST BE INSTALLED SO THE BURNERS AND IGNITION SOURCE ARE LOCATED NO LESS THAN 18 INCHES ABOVE THE FLOOR. THIS IS TO REDUCE THE RISK OF IGNITING FLAMMABLE VAPORS WHICH MAY BE PRESENT IN A GARAGE. ALSO, THE FURNACE MUST BE LOCATED OR PROTECTED TO AVOID PHYSICAL DAMAGE BY VEHICLES. FAILURE TO FOLLOW THESE WARNINGS CAN CAUSE A FIRE OR EXPLOSION, RESULTING IN PROPERTY DAMAGE, PERSONAL INJURY OR DEATH.

1. **IMPORTANT:** If installing the unit over a finished ceiling or living area, be certain to install an auxiliary condensate drain pan under the entire unit. Extend this auxiliary drain pan under any evaporator coil installed with the furnace and the open portion of the con-

densate drain assembly. See "Condensate Drain/Neutralizer" section for more details.

2. **IMPORTANT:** If using a cooling evaporator coil with this furnace. Be sure the air passes over the heat exchanger before passing over the cooling coil. The cooled air passing over the warm ambient air inside the heat exchanger tubes can cause condensation inside the tubes resulting in corrosion and eventual failure.
3. **IMPORTANT:** Install the furnace level. If it is not level, condensate cannot drain properly, possibly causing furnace shut down.

NOTE: These furnaces are approved for installation in attics, as well as alcoves, utility rooms, closets and crawlspaces. Make provisions to prevent freezing of condensate.

4. **IMPORTANT:** If this furnace is installed in a garage, attic or any other unconditioned space, a self-regulating heat tape must be installed around the condensate trap and along the entire length of the condensate drain in the unconditioned space.

The heat tape should meet the following requirements:

- a. The heat tape must be UL listed.
- b. Install the heat tape per the manufacturer's instructions for the entire length of drain pipe in the unconditioned space.
- c. The heat tape should be rated at 3 or 5 watts per foot at 120V.

5. **IMPORTANT:** If installing in a utility room, be sure the door is wide enough to:
 - a. allow the largest part of the furnace to pass; or
 - b. allow any other appliance (such as a water heater) to pass.
6. Install the furnace level and plumb. If it is not level, condensate cannot drain properly, possibly causing furnace to shut down.

IMPORTANT: Do not attempt to twin the modulating furnace. The characteristics of the ECM blower motor preclude twinning applications.

FIGURE 3
REMOVING SHIPPING BRACKET

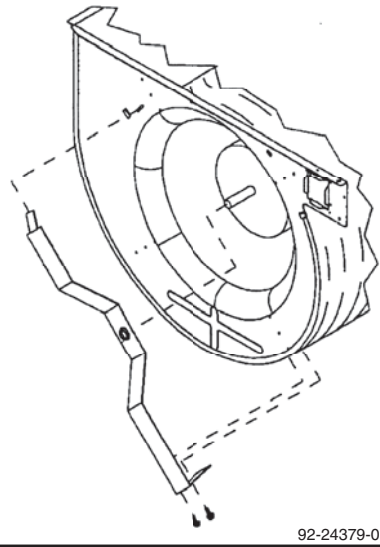

▲ CAUTION

SOME MODELS HAVE A SHIPPING BRACKET INSTALLED TO PROTECT THE BLOWER ASSEMBLY DURING SHIPPING.

LOCATE AND REMOVE THE SHIPPING BRACKET FROM THE SIDE OF THE BLOWER HOUSING BEFORE OPERATING UNIT. SEE FIGURE 3.

THE FOLLOWING MODELS INCLUDE THE ADDITIONAL BRACKET (WHICH MUST BE REMOVED) ON THE BLOWER ASSEMBLY:

**RGFG-09EZCMS
RGFG-10EZCMS
RGFG-12ERCMS**

CLEARANCE - ACCESSIBILITY

The design of forced air furnaces with models as listed in the tables under Figure 4 are certified by CSA Laboratories for the clearances to combustible materials shown in inches.

See name/rating plate and clearance label for specific model number and clearance information.

Service clearance of at least 24 inches is recommended in front of all furnaces.

FOR PURPOSES OF SERVICING THIS APPLIANCE, ACCESSIBILITY CLEARANCES, WHERE GREATER, SHOULD TAKE PRECEDENCE OVER FIRE PROTECTION CLEARANCES.

▲ WARNING

FURNACES MUST NOT BE INSTALLED DIRECTLY ON CARPET, TILE OR OTHER COMBUSTIBLE MATERIAL. INSTALLATION ON A COMBUSTIBLE MATERIAL OTHER THAN WOOD FLOORING MAY RESULT IN FIRE CAUSING DAMAGE, PERSONAL INJURY OR DEATH.

-GFG upflow furnaces are designed and certified for installation on combustible (wood only) floors.

Upflow furnaces are shipped with a bottom closure panel installed. When bottom return air is used, remove the panel by removing the two screws attaching the panel to the front base angle. See filter section for details (see Figure 5).

SITE SELECTION

1. Select a site in the building near the center of the proposed, or existing, duct system.
2. Give consideration to the vent system piping when selecting the furnace location. Vent from the furnace to the termination with minimal length and elbows.
3. Locate the furnace near the existing gas piping. If running a new gas line, locate the furnace to minimize the length and elbows in the gas piping.
4. Locate the furnace to maintain proper clearance to combustibles as shown in Figure 4.

FIGURE 4
PHYSICAL DIMENSIONS AND CLEARANCE TO COMBUSTIBLES, UPFLOW MODELS

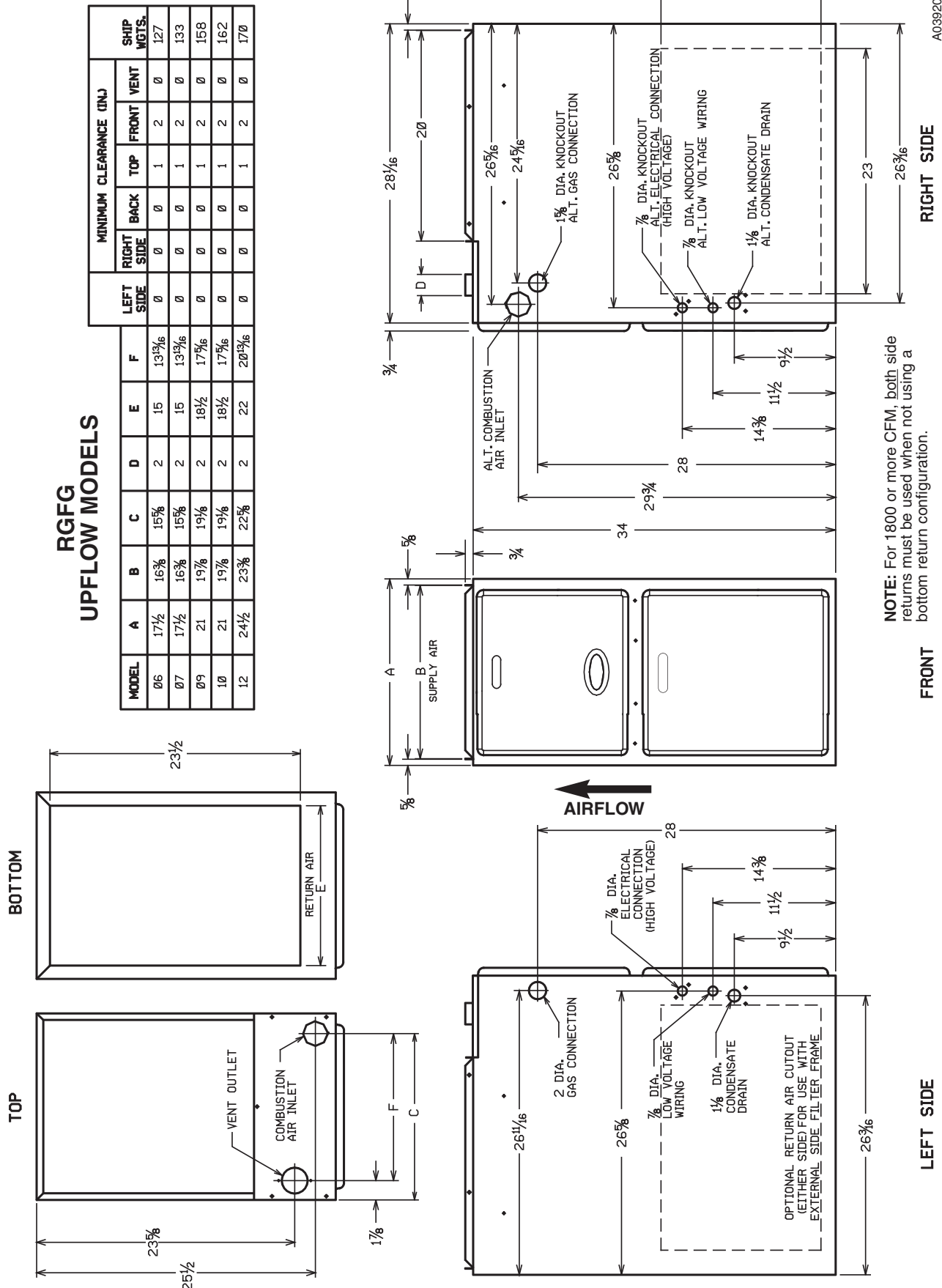

DUCTING

Proper airflow is required for the correct operation of this furnace.

Too little airflow can cause erratic operation and can damage the heat exchanger. The supply and return duct must carry the correct amount of air for heating and cooling if summer air conditioning is used.

Size the ducts according to acceptable industry standards and methods. The total static pressure drop of the supply and return duct should not exceed 0.2" w.c.

▲ WARNING

NEVER ALLOW THE PRODUCTS OF COMBUSTION FROM THE FLUE TO ENTER THE RETURN AIR DUCTWORK OR THE CIRCULATED AIR SUPPLY. ALL RETURN DUCTWORK MUST BE ADEQUATELY SEALED AND SECURED TO THE FURNACE WITH SHEET METAL SCREWS; AND JOINTS, TAPED. SECURE ALL OTHER DUCT JOINTS WITH APPROVED CONNECTIONS AND SEAL AIRTIGHT. WHEN A FURNACE IS MOUNTED ON A PLATFORM WITH RETURN THROUGH THE BOTTOM, IT MUST BE SEALED AIRTIGHT BETWEEN THE FURNACE AND THE RETURN AIR PLENUM. THE FLOOR OR PLATFORM MUST PROVIDE PHYSICAL SUPPORT OF THE FURNACE WITHOUT SAGGING, CRACKS, OR GAPS AROUND THE BASE, PROVIDING A SEAL BETWEEN THE SUPPORT AND THE BASE.

FAILURE TO PREVENT PRODUCTS OF COMBUSTION FROM BEING CIRCULATED INTO THE LIVING SPACE CAN CREATE POTENTIALLY HAZARDOUS CONDITIONS, INCLUDING CARBON MONOXIDE POISONING THAT COULD RESULT IN PERSONAL INJURY OR DEATH.

DO NOT, UNDER ANY CIRCUMSTANCES, CONNECT RETURN OR SUPPLY DUCTWORK TO OR FROM ANY OTHER HEAT PRODUCING DEVICE SUCH AS A FIREPLACE INSERT, STOVE, ETC. DOING SO MAY RESULT IN FIRE, CARBON MONOXIDE POISONING, EXPLOSION, PERSONAL INJURY OR PROPERTY DAMAGE.

IMPORTANT: Some high efficiency filters have a greater than normal resistance to airflow. This can adversely affect furnace operation. Be sure to check airflow if using any filter other than the factory-provided filter.

UPFLOW UNITS

1. Position the unit to minimize long runs of duct or runs of duct with many turns and elbows.

▲ WARNING

UPFLOW FURNACE: A SOLID METAL BASE PLATE MUST BE INSTALLED IN THE FURNACE BOTTOM WHEN USING SIDE AIR RETURN. FAILURE TO INSTALL A BASE PLATE COULD CAUSE THE PRODUCTS OF COMBUSTION TO CIRCULATE INTO THE LIVING SPACE AND CREATE POTENTIALLY HAZARDOUS CONDITIONS, INCLUDING CARBON MONOXIDE POISONING OR DEATH.

2. Open the return air compartment.
 - a. If using side return air, **do not remove the bottom base.**
 - b. Cut an opening in the side . The opening should be cut the full width of the knockouts on the unit.
NOTE: When using side return, return air plenums, RXGR-C17B, C21B and C24B are available from the factory.
 - c. Remove the bottom base, if using bottom return air. Remove the panel by removing the two screws attaching the base to the front base angle. See Figure 5.
NOTE: Where the maximum airflow is 1800 CFM or more, both sides or the bottom must be used for return air.
3. Connect the return duct or return air cabinet to the unit. Make the connection air tight to prevent entraining combustion gases from an adjacent fuel-burning appliance.
4. **Be sure to have adequate space for the unit filter.**
NOTE: DO NOT take return air from bathrooms, kitchens, furnace rooms, garages, utility or laundry rooms, or cold areas. DO NOT use a rear air return.
5. If summer air conditioning is desired, position the indoor coil on the supply air side of the unit. Insure that no air can bypass this coil.
6. Connect the supply air plenum to the furnace plenum opening.

IMPORTANT: If a flexible duct connector must be used, it **MUST** be rated for a minimum temperature of 250°F. continuous.

**FIGURE 5
BOTTOM PANEL REMOVAL**

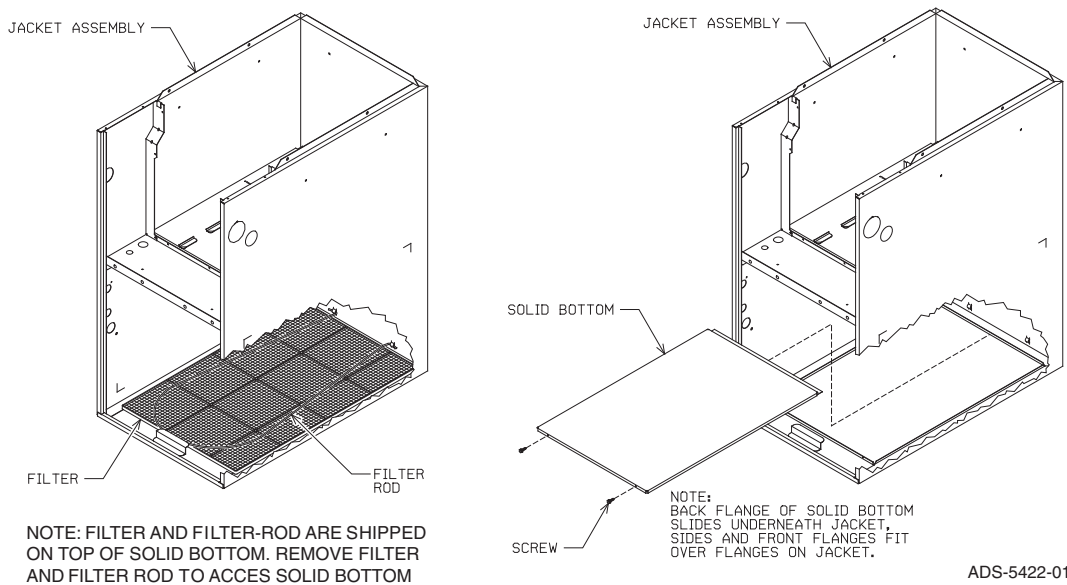

VENTING AND COMBUSTION AIR PIPING

GENERAL INFORMATION

▲ WARNING

READ AND FOLLOW ALL INSTRUCTIONS IN THIS SECTION. FAILURE TO PROPERLY VENT THIS FURNACE OR PROTECT IT FROM INADEQUATE COMBUSTION AIR CAN CAUSE CARBON MONOXIDE POISONING, AN EXPLOSION OR FIRE, RESULTING IN PROPERTY DAMAGE, PERSONAL INJURY OR DEATH.

OVER TEMPERATURE SAFETY SWITCHES

Furnaces are equipped with safety switches in the burner compartment to protect against over temperature conditions. If a switch is tripped, it must be manually reset.

▲ WARNING

DO NOT JUMPER OVERTEMPERATURE OR ANY OTHER SAFETY SWITCHES! IF ONE OF THESE OVER TEMPERATURE SWITCHES SHOULD TRIP, CALL A QUALIFIED INSTALLER, SERVICE AGENCY OR THE GAS SUPPLIER. DO NOT RESET THE SWITCHES WITHOUT TAKING CORRECTIVE ACTION. FAILURE TO DO SO CAN RESULT IN CARBON MONOXIDE POISONING OR DEATH. IF THIS UNIT IS INSTALLED IN A CLOSET, THE DOOR MUST BE CLOSED WHEN MAKING THIS CHECK.

REPLACE THE OVER TEMPERATURE SAFETY SWITCHES ONLY WITH THE IDENTICAL REPLACEMENT PART.

▲ WARNING

IN CANADA, PRODUCTS CERTIFIED FOR INSTALLATION AND INTENDED TO BE VENTED WITH PLASTIC VENT SYSTEMS (PVC, CPVC) MUST USE VENT SYSTEMS THAT ARE CERTIFIED TO THE STANDARD FOR TYPE BH GAS VENTING SYSTEMS, ULC S636.

THE COMPONENTS OF THE CERTIFIED MATERIAL MUST NOT BE INTERCHANGED WITH OTHER VENT SYSTEMS OR UNLISTED PIPE/FITTINGS.

PLASTIC COMPONENTS AND SPECIFIED PRIMERS AND GLUES OF THE CERTIFIED SYS-

TEM MUST BE FROM A SINGLE SYSTEM MANUFACTURER AND NOT INTERMIXED WITH OTHER SYSTEM MANUFACTURER'S PARTS.

NOTE: INLET AIR PIPING IS NOT CONSIDERED TO BE A PART OF THE "VENTING SYSTEM". THE REQUIREMENT THAT VENT MATERIAL BE CERTIFIED TO ULC S636 DOES NOT APPLY TO INLET AIR PIPING.

INSTALLATION WITH PRE-EXISTING VENT SYSTEMS

When the installation of this furnace replaces an existing furnace that is removed from a vent system serving other appliances (such as a water heater), the existing vent system is likely to be too large to properly vent the remaining attached appliances.

Follow the steps below with each appliance remaining connected to the original common vent system. Place the appliance to be tested in operation, while the other appliances remaining connected to the common vent system are not in operation. Test the operation of each appliance individually by the following method.

1. Permanently seal any unused openings in the common venting system.
2. Visually inspect the venting system for proper size and horizontal pitch and determine that there is no blockage, restriction, leakage, corrosion or other deficiencies which could cause an unsafe condition.
3. If practical, close all building doors, windows and all doors between the space where the appliances remaining connected to the common venting system are located. Turn on clothes dryers and any appliance not connected to the common venting system. Turn on any exhaust fans, such as range hoods and bathroom exhausts, so they will operate at maximum speed. Do not operate a summer exhaust fan. Close fireplace dampers.
4. Follow the lighting instructions. Place the appliance being inspected into operation. Adjust the thermostat so the appliance will operate continuously.
5. Test for spillage at the draft hood relief opening after 5 minutes of main burner operation. Use the flame of a match or candle, or smoke from a cigarette, cigar or pipe.

6. After it has been determined that each appliance that remains connected to the common venting system properly vents (when tested as outlined above), return doors, windows, exhaust fans, fireplace dampers and any other gas-burning appliance to their previous conditions of use.

7. If improper venting is observed during any of the above tests, resize the common venting system. Refer to latest edition of the National Fuel Gas Code ANSI Z223.1, or the CSA-GAMA venting tables for Category I furnaces.

NOTE: For U.S. installations only. Schedule 40 ABS-DWV pipe and fittings may be used as an alternate to PVC pipe for the combustion air inlet and vent pipes.

NOTE: For U.S. installations only. Cellular core PVC is also approved for use. It must be schedule 40 PVC-DWV cellular pipe manufactured under ASTM F-891.

JOINING PIPE AND FITTINGS

▲ WARNING

PVC SOLVENT CEMENTS AND PRIMERS ARE HIGHLY FLAMMABLE. PROVIDE ADEQUATE VENTILATION AND DO NOT ASSEMBLE COMPONENTS NEAR HEAT SOURCE OR AN OPEN FLAME. DO NOT SMOKE. AVOID SKIN OR EYE CONTACT. OBSERVE ALL CAUTIONS AND WARNINGS PRINTED ON MATERIAL CONTAINERS. FAILURE TO FOLLOW THESE GUIDELINES MAY RESULT IN FIRE, EXPLOSION OR ASPHYXIATION CAUSING PERSONAL INJURY OR DEATH.

All pipe, fittings, solvent cement, primers and procedures must conform to American National Standard Institute and American Society for Testing and Materials (ANSI/ASTM) standards as shown below:

IMPORTANT: The plastic combustion air and venting components are MADE of PVC. If using ABS piping, ensure that the solvent cement is compatible for joining PVC to ABS components or use a mechanical connection that can withstand the vent temperatures and is corrosion resistant.

CEMENTING JOINTS

Properly seal all joints in the PVC vent using the following materials and procedures:

PVC CLEANER-PRIMER AND PVC MEDIUM-BODY SOLVENT CEMENT

IMPORTANT: After cutting pipe, remove all ragged edges and burrs. This is important to prevent increase in pressure drop throughout the system.

1. Cut pipe end square. Chamfer edge of pipe. Clean fitting socket and pipe joint area of all dirt, grease and moisture.
2. After checking pipe and socket for proper fit, wipe socket and pipe with cleaner-primer. Apply a liberal coat of primer to inside surface of socket and outside of pipe. READ INSTRUCTIONS INCLUDED WITH THE PRIMER FOR PROPER INSTALLATION.
3. Apply a thin coat of cement evenly in the socket. Quickly apply a heavy coat of cement to the pipe end and insert pipe into fitting with a slight twisting movement until it bottoms out.

NOTE: Cement must be fluid; if not, recoat.

4. Hold the pipe in the fitting for 30 seconds to prevent the tapered socket from pushing the pipe out of the fitting.

5. Wipe all excess cement from the joint with a rag. Allow 15 minutes before handling. Cure time varies according to fit, temperature and humidity.

NOTE: Stir the solvent cement frequently while using. Use a natural bristle, one inch wide brush or the applicator supplied with the can.

IMPORTANT: For Proper Installation DO NOT use solvent cement that has become curdled, lumpy or thickened. DO NOT thin. Observe shelf precautions printed on containers. For application below 32°F, use only low-temperature-type solvent cement.

For correct installation of the vent pipe, follow the instructions provided by the manufacturers of the pipe, primer and solvent.

EQUIVALENT VENTING – ASSIGNING VENT LENGTH TO ELBOWS

This section applies to venting tables in both the NON-DIRECT and DIRECT VENT tables in this book. Vent tables are provided only in equivalent length and do not reference elbows or a maximum number of elbows. Instead, elbows are assigned a length as described below. The length determined for each elbow is subtracted from the max vent length in the tables to determine how much straight vent pipe (in ft) can still be used.

PIPE & FITTING MATERIAL	ASTM SPECIFICATION
Schedule 40 PVC (Pipe)	D1785
Schedule 40 PVC (Cellular Core Pipe)	F891
Schedule 40 PVC (Fittings)	D2466
SDR-21PVC (Pipe)	D2241
SDR-26 PVC (Pipe)	D2241
Schedule 40 ABS Cellular Core DWV (Pipe)	F628
Schedule 40 ABS (Pipe)	D1527
Schedule 40 ABS (Fittings)	D2468
ABS-DWV (Drain Waste & Vent) (Pipe & Fittings)	D2661
PVC-DWV (Drain Waste & Vent) (Pipe & Fittings)	D2665

TABLE 1

Fitting Type	Equivalent Length
45° Standard Elbow	5 feet of pipe
90° Standard Elbow	10 feet of pipe
45° Long-Sweep Elbow	2-1/2 feet of pipe
90° Long-Sweep Elbow	5 feet of pipe

There are several different types of elbows that can be used for constructing a vent system. The drawings below show the dimensions of common 1/4 bend and 1/4 bend long sweep 90 degree elbows from ASTM 3311, Standard Specification for Drain, Waste and Vent (DWV) Plastic Fittings Patterns.

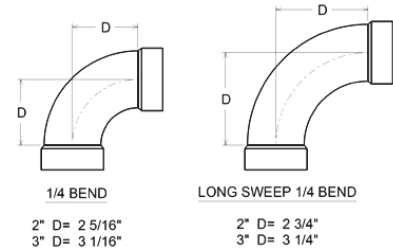

A long sweep 1/4 bend 90 degree (long radius) elbow has an equivalent length of 5 feet of straight pipe for either 2 or 3 inch plastic pipe. A standard 90° elbow has an equivalent length of 10 feet of pipe. This equivalent length can be used in circumstances where it might be necessary to lengthen the vent at the outside of the structure, such as in areas with large accumulations of snow in winter. Table 1 shows the equivalent lengths of different types of elbows:

With the equivalent length vent concept a vent system can be used any number of elbows and length of straight pipe as long as the maximum equivalent vent length is not exceeded.

Example:

An RGRC-06 direct vent installation needs a 31 foot long vent run with 5 elbows and 2 inch pipe.

31 feet of 2 inch pipe = 31
equivalent feet

5 - 1/4 bend long sweep
elbows = 25
equivalent feet

Total = 56
equivalent feet

Since the maximum equivalent vent length for an RGRC-06 is 60 feet, this installation is acceptable.

If the same installation tried to use standard elbows:

31 feet of 2 inch pipe = 31
equivalent feet

5 - standard 90 degree
= 50
equivalent feet

Total = 81
equivalent feet

And this installation is not acceptable as it exceeds the 60 foot maximum listed for the RGRC-06 model.

NON-DIRECT VENT PIPE INSTALLATION (FOR VERTICAL TERMINATIONS ONLY)

COMBUSTION AIR

▲ WARNING

ALWAYS PROVIDE THIS FURNACE AND ANY OTHER FUEL BURNING APPLIANCE WITH ENOUGH FRESH AIR FOR PROPER COMBUSTION AND VENTILATION OF THE FLUE GASES. MOST BUILDING CODES REQUIRE THAT OUTSIDE AIR BE SUPPLIED INTO THE FURNACE AREA. FAILURE TO DO SO CAN CAUSE DEATH FROM CARBON MONOXIDE POISONING.

Provide adequate facilities for combustion and ventilation air in accordance with section 5.3, Air for Combustion and Ventilation of the National Fuel Gas Code, ANSI Z223.1 - latest edition; CAN/CGA B149.1 and .2, or applicable provisions of the local building codes. These combustion and ventilation facilities must not be obstructed.

IMPORTANT: Air for combustion and ventilation must not come from a corrosive atmosphere. Any furnace failure due to corrosive elements in the atmosphere is excluded from warranty coverage.

The following types of installation (but not limited to the following) REQUIRE OUTDOOR AIR for combustion, due to chemical exposures:

- Commercial buildings
- Buildings with indoor pools
- Furnaces installed in laundry rooms
- Furnaces in hobby or craft rooms
- Furnaces installed near chemical storage areas.

Exposure to the following substances in the combustion air supply (but not limited to the following) also REQUIRE OUTDOOR AIR for combustion:

- Permanent wave solutions
- Chlorinated waxes and cleaners
- Chlorine-based swimming pool chemicals
- Water softening chemicals
- De-icing salts or chemicals
- Carbon Tetrachloride
- Halogen type refrigerants
- Cleaning solvents (such as perchloroethylene)
- Printing inks, paint removers, varnishes, etc.
- Hydrochloric acid
- Cements and glues
- Anti-static fabric softeners for clothes dryers
- Masonry acid washing materials

Combustion air must be free of acid forming chemicals such as sulphur, fluorine, and chlorine. These elements are found in aerosol sprays, detergents, bleaches, cleaning solvents, air fresheners, paint and varnish removers, refrigerants and many other commercial and household products. Vapors from these products when burned in a gas flame form acid compounds. The acid compounds increase the dew point temperature of the flue products and produce highly corrosive condensate.

▲ WARNING

ALL FURNACE INSTALLATIONS MUST COMPLY WITH THE NATIONAL FUEL GAS CODE AND LOCAL CODES TO PROVIDE ADEQUATE COMBUSTION AND VENTILATION AIR FOR THE FURNACE. FAILURE TO DO SO CAN RESULT IN EXPLOSION, FIRE, PROPERTY DAMAGE, CARBON MONOXIDE POISONING, PERSONAL INJURY OR DEATH.

Combustion air requirements are determined by whether the furnace is in an open (unconfined) area or in a confined space such as a closet or small room.

FURNACE LOCATED IN AN UNCONFINED SPACE

Using indoor air for combustion.

An unconfined space must have at least 50 cubic feet for each 1,000 BTUH of the **total input for all appliances** in the space. Here are a few examples of the room sizes required for different inputs. The sizes are based on 8 foot ceilings. See Table 2.

**TABLE 2
UNCONFINED SPACE DIMENSIONS**

BTUH Input	Minimum Sq. Feet With 8 foot Ceiling	Typical Room Size
60,000	375	15' x 25' OR 19' x 20'
75,000	469	15' x 32' OR 20' x 24'
90,000	563	20' x 28' OR 24' x 24'
105,000	657	20' x 33' OR 26' x 25'
120,000	750	25' x 30' OR 24' x 32'

If the open space containing the furnace is in a building constructed to severely limit outside air infiltration (contemporary energy efficient construction methods), outside air may still be required for the furnace to operate and vent properly. Outside air openings should be sized the same as for a confined space.

FURNACE LOCATED IN A CONFINED SPACE.

A confined space (any space smaller than shown before as “unconfined”) must have **openings into the space, which are located in accordance with the requirements set forth in the following subsections A and B.** The openings must be sized by how they connect to the heated area or to the outside, and by the input of all appliances in the space.

If the confined space is within a building with tight construction, combustion air must be taken from outdoors or areas freely communicating with the outdoors.

BTUH Input	Free Area Each Opening
60,000	100 square inches
75,000	100 square inches
90,000	100 square inches
105,000	105 square inches
120,000	120 square inches

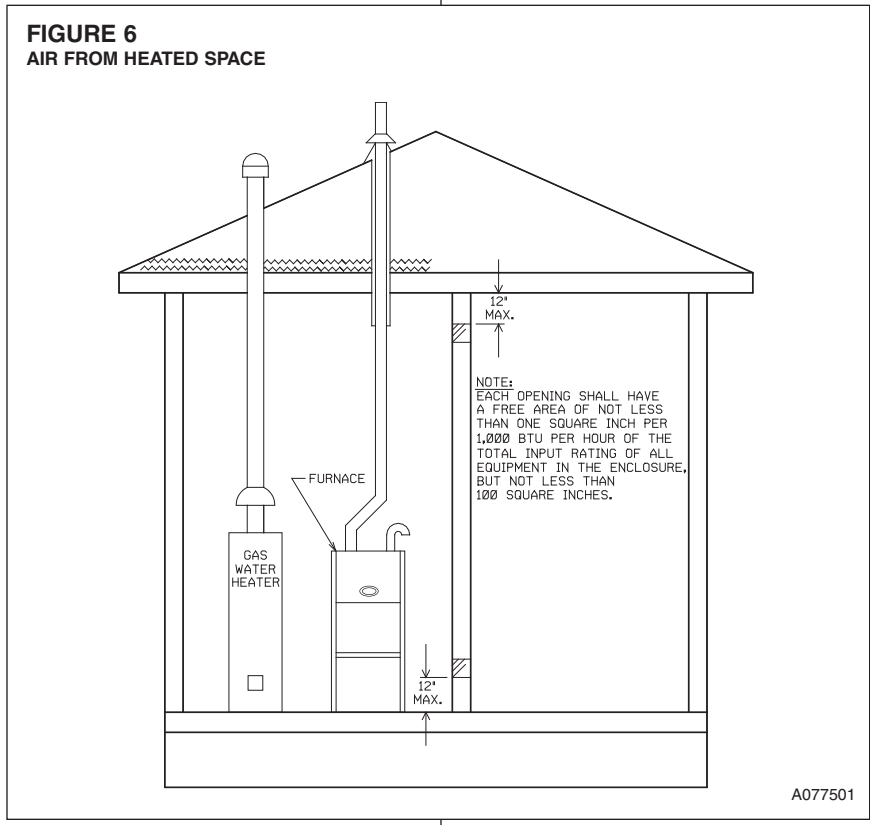

A. USING INDOOR AIR FOR COMBUSTION

IMPORTANT: DO NOT take air from a heated space with a fireplace, exhaust fan or other device that may produce a negative pressure.

If combustion air is taken from the heated area (see Figure 6), the openings must **each** have at least **100 square inches of free area.** Each opening must have at least **one square inch of free area for each 1,000 BTUH of total input** in the space. See Table 3.

B. USING OUTDOOR AIR FOR COMBUSTION

IMPORTANT: Do not take air from an attic space that is equipped with power ventilation.

The confined space must communicate with the outdoors in accordance with Methods 1 or 2. The minimum dimension of air openings shall not be less than 3 inches. Where ducts are used, they shall be of the same cross-sectional area as the free area of the openings to which they connect.

Method 1

Two permanent openings, one located within 12 inches of the top and one located within 12 inches of the bottom of the enclosure, shall be provided. The openings shall communicate directly, or by ducts, with the outdoors or spaces (crawl or attic) that freely communicate with the outdoors.

- a. Where directly communicating with the outdoors or where communicating to the outdoors through vertical ducts as shown in Figure 7, each opening shall have a minimum free area of 1 square inch for each 4000 BTUH of total appliance input rating in the enclosure. See Table 4.

BTUH Input	Free Area Each Opening	Round Pipe Size
60,000	15.00 square inches	5"
75,000	18.75 square inches	5"
90,000	22.50 square inches	6"
105,000	26.25 square inches	6"
120,000	30.00 square inches	7"

- b. Where communicating with outdoors through horizontal ducts, each opening shall have a minimum free area of 1 square inch for each 2000 BTUH of total input rating of all equipment in the enclosure. See Table 5 and Figure 8.

TABLE 5 HORIZONTAL OUTDOOR AIR OPENING DIMENSIONS		
BTUH Input	Free Area Each Opening	Round Pipe Size
60,000	30.00 square inches	7"
75,000	37.50 square inches	7"
90,000	45.00 square inches	8"
105,000	52.50 square inches	9"
120,000	60.00 square inches	9"

Method 2

One permanent opening, located within 12 inches of the top of the enclosure, shall be permitted where the equipment has clearances of at least 1 inch from the sides and back and 6 inches from the front of the appliance. The opening shall directly communicate with the outdoors or communicate through a vertical or horizontal duct to the outdoors or spaces (crawl or attic) that freely communicate with the outdoors, and shall have a minimum free area of:

- a. One square inch for each 3000 BTUH of the total input rating of all equipment located in the enclosure (see Table 6), and
- b. Not less than the sum of the areas of all vent connectors in the confined space.

If the unit is installed where there is an exhaust fan, sufficient ventilation must be provided to prevent the exhaust fan from creating a negative pressure.

TABLE 6 VERTICAL OR HORIZONTAL OUTDOOR AIR OPENING DIMENSIONS		
BTUH Input	Free Area Each Opening	Round Pipe Size
60,000	20.00 square inches	6"
75,000	25.00 square inches	6"
90,000	30.00 square inches	7"
105,000	35.00 square inches	7"
120,000	40.00 square inches	8"

Combustion air openings must not be restricted in any manner.
CONSULT LOCAL CODES FOR SPECIAL REQUIREMENTS.

**FIGURE 7
AIR FROM ATTIC/CRAWL SPACE**

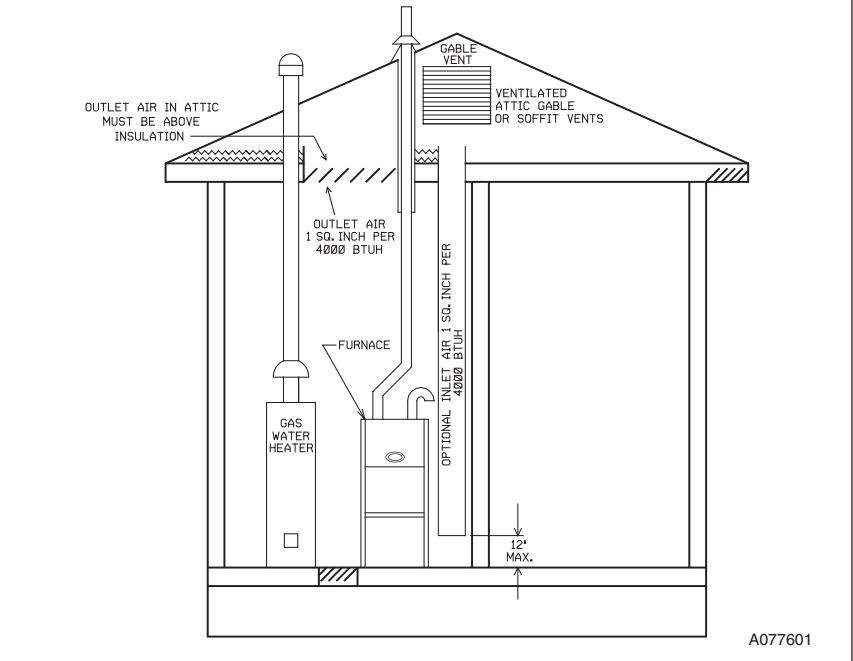

A077601

**FIGURE 8
OUTSIDE AIR USING A HORIZONTAL INLET & OUTLET**

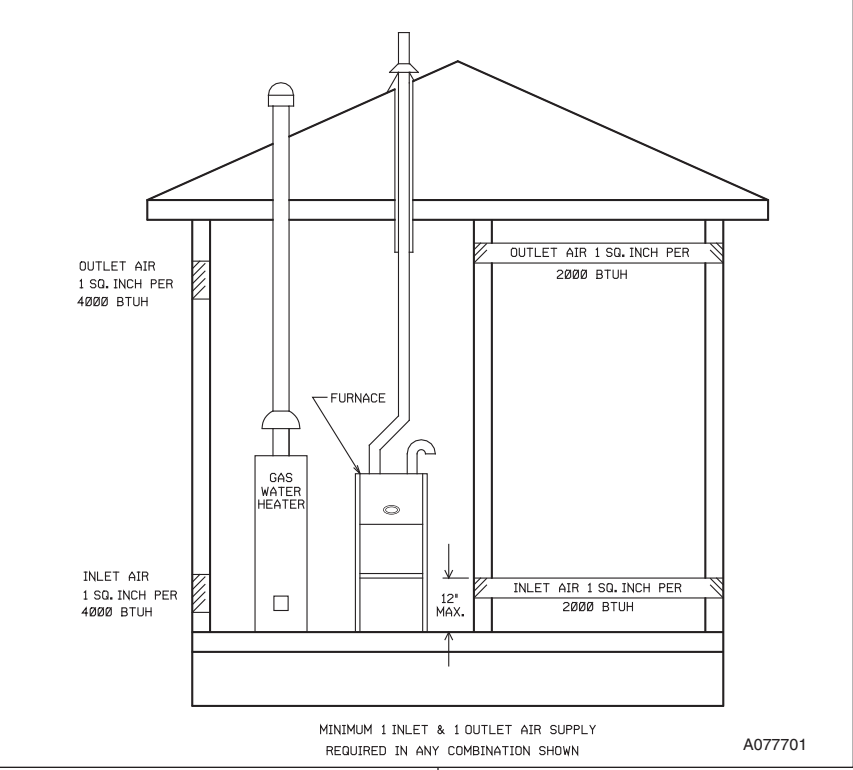

MINIMUM 1 INLET & 1 OUTLET AIR SUPPLY
REQUIRED IN ANY COMBINATION SHOWN

A077701

INSTALLATION GUIDELINES

IMPORTANT: When installed as a non-direct furnace, only vertical terminations are allowed. Do not use horizontal terminations when the furnace is installed with a non-direct vent.

All exhaust vent piping must be installed in compliance with Part 7, Venting of Equipment, of the latest edition of the National Fuel Gas Code NFPA 54/ANSI A223.1, or CAN/CGA-B149.1 and .2, local codes or ordinances and these instructions.

VENTING GUIDELINES - Non-Direct Vent

- IMPORTANT:** Do not common vent with any other appliance. Do not install in the same chase or chimney with a metal or high temperature plastic pipe from another gas or fuel-burning appliance unless the required minimum clearances to combustibles are maintained between the PVC pipe and other pipes.
- Use only medium or long radius sweep elbows, such as PVC-DWV elbows.**
NOTE: For upflow installations, extend the exhaust pipe a minimum of 18" vertically above the furnace cabinet before turning the vent.
- Vertical vent piping is preferred.**
- Install all horizontal piping as follows:
 - Slope horizontal vent piping upward a minimum of 1/4" per foot of run so that condensate drains toward the furnace.
 - Support horizontal vent piping at least every four feet. No sags or dips are permitted.
- Insulate all vent runs through unconditioned spaces where below-freezing temperatures are expected, with 1" thick medium density, foil faced fiber glass or equivalent Rubatex/Armaflex insulation. For horizontal runs where water may collect and freeze, wrap the vent pipe with self-regulating, 3 or 5 Watt heat tape. The heat tape must be U.L. listed and installed per the manufacturer's instructions.
- All piping between the furnace and the roof penetration is 2" or 3" as specified in Table 7. Table 7 lists the maximum allowable exhaust vent pipe length for the number of elbows used, based on the furnace size.
IMPORTANT: Use Only standard vertical terminations when installing the modulating furnace as a non-direct vent appliance.

- The minimum vent length is **5 feet**.
- All piping through the roof is 2".
When using 3" pipe, reduce to 2" within 18" of the inside of the roof.
- Vertical through-the-roof installations do not require any special vent termination. **Use 2" PVC pipe extending a minimum of 12**

- inches above the anticipated level of snow accumulation.**
- Elbows must be a minimum of 15" apart.
 - No screens may be used to cover combustion air or exhaust.

**► TABLE 7
NON-DIRECT VENT APPLICATIONS
MAXIMUM ALLOWABLE LENGTH IN FEET OF EXHAUST PIPE**

UPFLOW FURNACES RGFG			
FURNACE INPUT	PIPE SIZE	TERMINATION (VERTICAL VENT TERMINATIONS ONLY)	MAX. EQUIVALENT LENGTH OF VENT (SEE EQUIVALENT VENT SECTION ON PAGE 13)
			1 - 2
60,000	2"	STANDARD	70' (ALL)
75,000	2"	STANDARD	70' (ALL)
90,000	3"	STANDARD	70' (ALL)
105,000	3"	STANDARD	70' (ALL)
120,000	3"	STANDARD	70' (ALL)

NOTES:

- N.R. - NOT RECOMMENDED.
- MAXIMUM OF 6 ELBOWS MAY BE USED. DO NOT COUNT ELBOWS IN ALTERNATE TERMINATION KIT. MEDIUM OR LONG SWEEP ELBOWS MAY BE USED.
- A 45 OR 22.5 DEGREE ELBOW IS CONSIDERED ONE ELBOW.
- CONCENTRIC TERMINATION NO. RXGY-E03A IS FOR THRU-THE-ROOF OR THRU-THE-WALL VENTING.
- USE KITS RXGY-D02 OR D02A (2") OR RXGY-D03 OR D03A (3") FOR STANDARD OR ALTERNATE THRU-THE-WALL VENTING.
- USE KITS RXGY-D04 OR D04A FOR ALTERNATE VENTING OF 120,000 BTUH UNITS WITH LONG RUNS.
- NO SCREENS MAY BE USED TO COVER COMBUSTION AIR AND EXHAUST.
* A = 17½" CABINET WIDTH
B = 21" CABINET WIDTH
- ALL HORIZONTAL VENTING MUST BE DONE WITH DIRECT VENTING (2-PIPE). FURNACES INSTALLED AS NON-DIRECT VENT MUST BE TERMINATED VERTICALLY.

DIRECT VENT PIPE INSTALLATION

▲ WARNING

READ AND FOLLOW ALL INSTRUCTIONS IN THIS SECTION. FAILURE TO PROPERLY VENT THIS FURNACE CAN CAUSE CARBON MONOXIDE POISONING OR AN EXPLOSION OR FIRE, RESULTING IN PROPERTY DAMAGE, PERSONAL INJURY OR DEATH.

Direct vent installations require a dedicated combustion air and venting system. All air for combustion is taken from outside and all combustion products are discharged to the outdoors. **Therefore, no ventilation or combustion air openings are required.**

INSTALLATION GUIDELINES

All exhaust piping must be installed in compliance with Part 7, "Venting of Equipment," of the latest edition of the National Fuel Gas Code NFPA 54, 90A and 90B ANSI Z223.1-, local codes or ordinances and these instructions.

1. **IMPORTANT:** Do not common vent with any other appliance. Do not install in the same chase or chimney with a metal or high temperature plastic pipe from another gas or fuel-burning appliance unless the required minimum clearances to combustibles are maintained between the approved PVC pipe and other pipes.
2. **Use only medium or long radius sweep elbows.**
NOTE: For all installations. Extend the combustion air exhaust pipe a minimum of 18" vertically above the furnace cabinet before turning the vent.
3. **Vertical piping is preferred.**
4. Install all horizontal piping as follows:
 - Slope horizontal vent piping upward a minimum of 1/4" per foot of run so that condensate drains toward the furnace.
 - Support horizontal vent piping at least every four feet. No sags or dips are permitted.

**► TABLE 8
DIRECT VENT APPLICATIONS
MAXIMUM ALLOWABLE LENGTH IN FEET OF EACH EXHAUST PIPE AND INTAKE PIPE**

UPFLOW RGFG FURNACES				
FURNACE INPUT	PIPE SIZE	TERMINATION	VENT TERMINATION KIT RECOMMENDED	MAX. EQUIVALENT LENGTH OF VENT (SEE EQUIVALENT VENT SECTION ON PAGE 13)
				1 - 2
60,000	2"	STANDARD	RXGY-D02A/G02A	70' (ALL)
		CONCENTRIC	RXGY-E03A/G02A	
		ALTERNATE	RXGY-D02A	
75,000	2"	STANDARD	RXGY-D02A/G02A	70' (ALL)
90,000	3"	STANDARD	RXGY-D03A/G02A	70' (ALL)
		CONCENTRIC	RXGY-E03A/G02A	
		ALTERNATE	RXGY-D03A	
105,000	3"	STANDARD	RXGY-D03A/G02A	70' (ALL)
		CONCENTRIC	RXGY-E03A/G02A	
		ALTERNATE	RXGY-D03A	
120,000	3"	STANDARD	RXGY-D03/G02A	70' (ALL)
		CONCENTRIC	RXGY-E03A/G02A	
		ALTERNATE	RXGY-D03A	70' (ALL)
		ALTERNATE	RXGY-D04A	70' (ALL)

NOTES:

1. N.R. - NOT RECOMMENDED.
2. MAXIMUM OF 6 ELBOWS MAY BE USED. DO NOT COUNT ELBOWS IN ALTERNATE TERMINATION KIT. MEDIUM OR LONG SWEEP ELBOWS MAY BE USED.
3. A 45 OR 22.5 DEGREE ELBOW IS CONSIDERED ONE ELBOW.
4. CONCENTRIC TERMINATION NO. RXGY-E03 IS FOR THRU-THE-ROOF OR THRU-THE-WALL VENTING.
5. USE KITS RXGY-DO2 (2") OR RXGY-D03 (3") FOR STANDARD OR ALTERNATE THRU-THE-WALL VENTING.
6. USE KITS RXGY-D04 FOR ALTERNATE VENTING OF 120,000 BTUH UNITS WITH LONG RUNS.
7. NO SCREENS MAY BE USED TO COVER COMBUSTION AIR AND EXHAUST.
* A = 17½" CABINET WIDTH
B = 21" CABINET WIDTH
- ** ALTERNATE VENT NOT PERMITTED ON DOWNFLOW/HORIZONTAL MODELS.
8. ALL HORIZONTAL VENTING MUST BE DONE WITH DIRECT VENTING (2-PIPE). FURNACES INSTALLED AS NON-DIRECT VENT MUST BE TERMINATED VERTICALLY.

FIGURE 9
STANDARD VERTICAL DIRECT VENTING
UPFLOW MODEL SHOWN (TYPICAL FOR DOWNFLOW/HORIZONTAL MODELS)

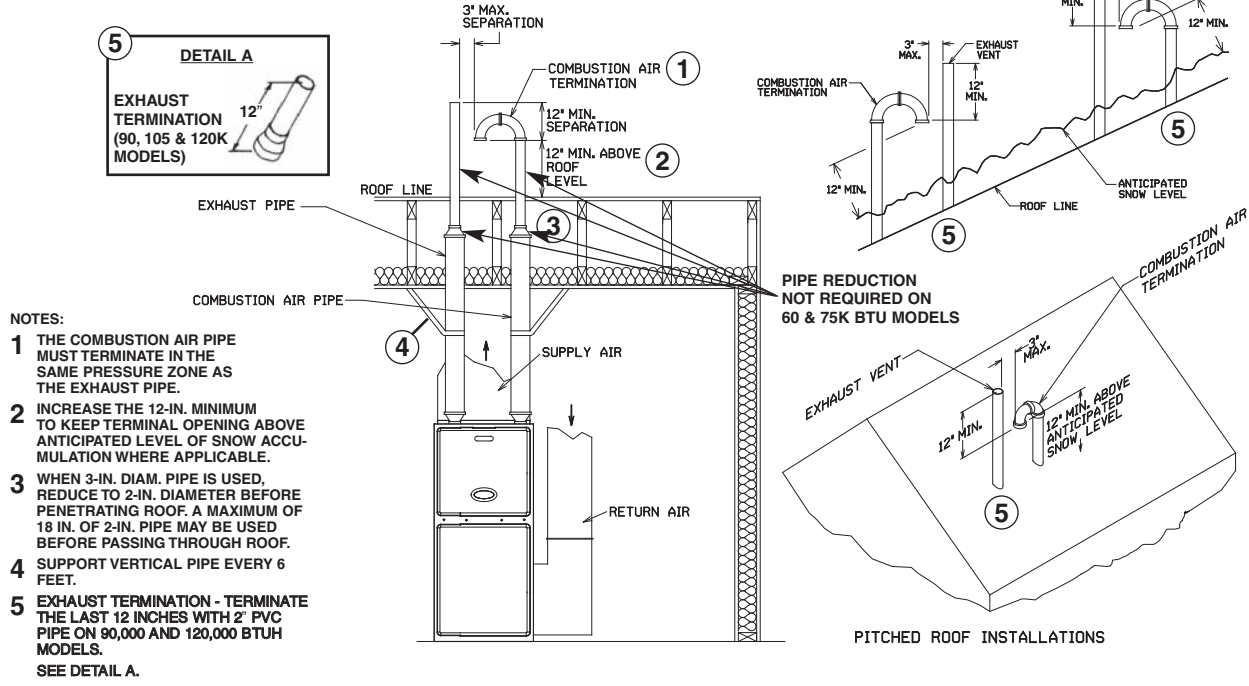

ST-A0407-00

5. Insulate all vent runs through unconditioned spaces where below-freezing temperatures are expected with 1" thick medium density, foil faced fiber glass or equivalent Rubatex/Armaflex insulation. For horizontal runs where water may collect, wrap the vent pipe with self-regulating, 3 or 5 Watt heat tape. The heat tape must be U.L. listed and installed per the manufacturer's instructions.
6. All piping between the furnace and the roof or outside wall penetration is 2" or 3" as specified in Table 8. Table 8 lists the maximum allowable length for the exhaust vent pipe and intake air pipe for the number of elbows used, based on the type of termination and furnace size.
7. The minimum vent length is 5 feet.
8. All piping through the roof or outside wall is 2". **When using 3" pipe, reduce to 2" within 18" of the inside of the roof or outside wall (except 120,000 BTUH model using the RXGY-D04 or D04A Horizontal Vent Kit).**
9. Terminate the vent using one of the following termination options.

10. Elbows must be a minimum of 15" apart.
11. No screens may be used to cover combustion air or exhaust.

VERTICAL TERMINATIONS
STANDARD VERTICAL TERMINATIONS (See Figure 9)

Combustion Air Piping: Use two medium-radius sweep elbows to keep the inlet downward and prevent the entry of rain. **The inlet opening of the combustion air termination must be a minimum of 12" above the anticipated level of snow accumulation.**

Exhaust Vent Piping: The exhaust vent must terminate at least 12 inches above the combustion air termination inlet. The maximum length of the exposed vent pipe above the roof is 30".

CONCENTRIC TERMINATIONS

**CONCENTRIC VENT KIT
NO. RXGY-E03A (SEE FIGURE 10)**

This kit is for vertical and horizontal intake air/vent runs. One 5-in. diameter hole is required for installation. See Figure 10 for the general layout. Complete installation instructions are included with the kit.

NOTE: The following IPEX brand concentric terminations (System 636) may be purchased in the field and used in place of factory supplied kits:

3" Concentric Kit – Item # 196006

**FIGURE 10
CONCENTRIC VENT KIT NO. RXGY-E03A
(DIRECT VENT INSTALLATIONS)**

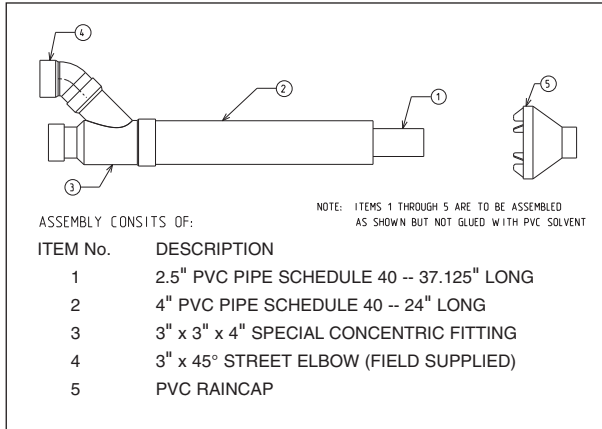

HORIZONTAL INSTALLATION

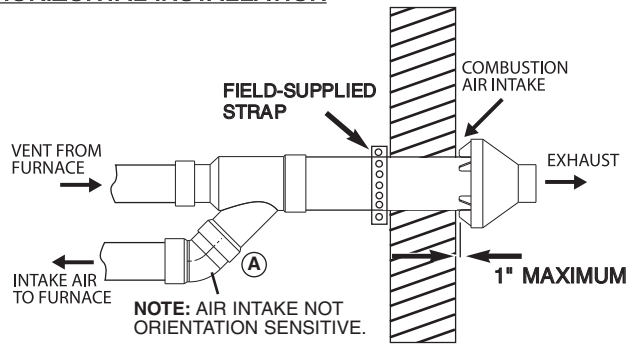

VERTICAL INSTALLATION

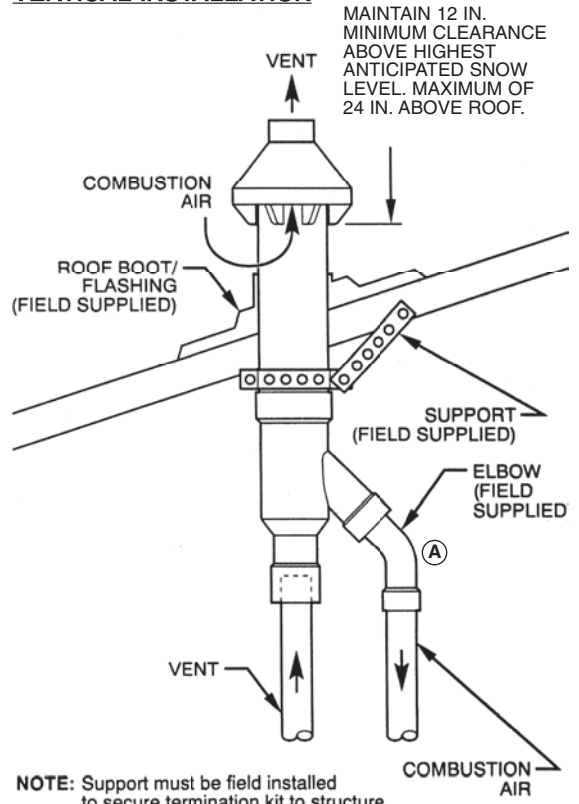

(A) NOTE: Drain tee is not needed for the inlet pipe.

INSTALLATION – RXGY-G02A Side Wall Vent

This termination for horizontal venting only.

This termination for direct vent application only.

Important: Do not install on the prevailing winter wind side of the structure

Note: Multi-venting-No common venting.

FIGURE 11
VENT KIT INSTALLATION OPTIONS

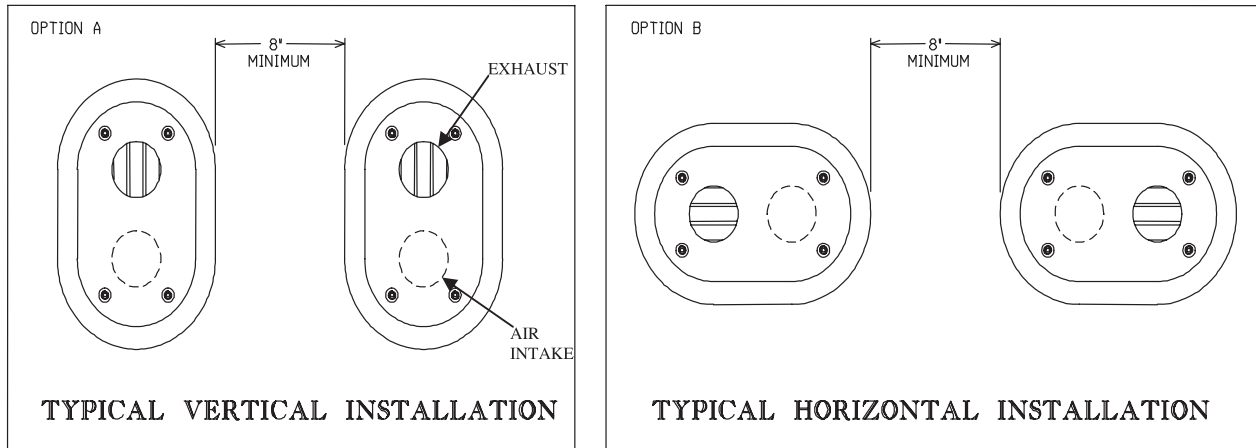

NOTE: Install the vent and air intake piping into the vent plate openings. Seal all gaps between the pipes and wall. **Be Sure To Use Silicone Sealant** to seal the vent pipe to the vent cap to permit field disassembly for annual inspection and cleaning. Also seal all pipe penetrations in wall. To prevent possibility of condensate freeze-up or recirculation, **do not install vent kits one above the other.**

FIGURE 12
TYPICAL INSTALLATION

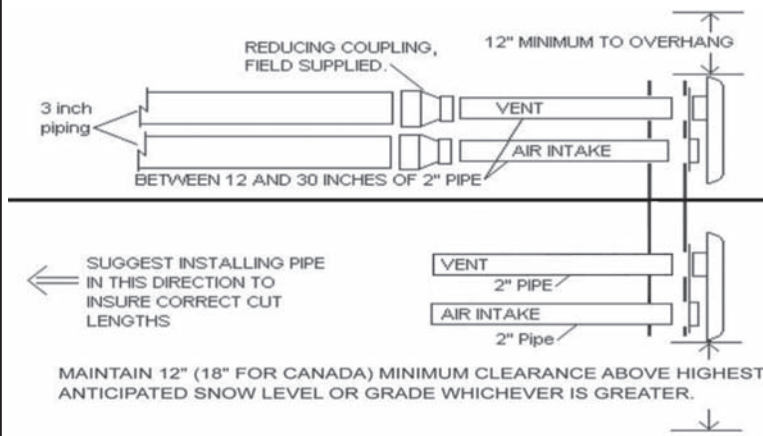

For 90000 thru 120000 BTUH models- reduce to a length between 12 inches and 30 inches of 2 inch pipe.

Note: Vent should protrude a maximum of 2-1/4" beyond vent plate. Air intake should protrude a maximum of 1 inch beyond vent plate.

Seal all wall cavities.

ST-A1075

HORIZONTAL TERMINATIONS

All horizontal venting must be done with direct venting (2 pipe). Furnaces installed as non-direct vent must be terminated vertically.

STANDARD HORIZONTAL TERMINATIONS (SEE FIGURE 13)

NOTE: All furnaces with horizontal air intakes (except those using horizontal concentric vent kit RXGY-E03A) must have a drain tee assembly and trap installed in the combustion air pipe as close to the furnace as possible. This is to drain any water that may enter the combustion air pipe to prevent it from entering the furnace vestibule area. These parts are included in horizontal vent kits RXGY-D02A, RXGY-D03A and RXGY-D04A.

NOTE: The combustion air and exhaust terminations must be at least 12 inches above grade or anticipated snow levels. Use alternate horizontal terminations when termination locations are limited and higher snow levels are anticipated.

NOTE: Ensure the location of the combustion air inlet with respect to the exhaust vent terminal complies with Figure 13, detail C.

Combustion Air Piping: Use a 2" PVC coupling with a wind deflector vane (provided) installed as follows:

1. Install a 2" coupling to the combustion air pipe at the outside wall to prevent the termination from being pushed inward.
2. Cut a 2 1/4" length of 2" PVC pipe and connect this to the coupling.
3. Connect another 2" coupling to the end of the 2 1/4" length of pipe. Terminate this outer coupling 4 inches from the wall.
4. Attach the vane in the final 2" coupling in the vertical position with PVC cement.

IMPORTANT: To insure proper furnace operation, install the vane in the vertical position as shown in Figure 13, Detail B. Failure to install the vane properly can result in nuisance tripping of the pressure switch.

Exhaust Vent Piping:
60,000 and 75,000 BTUH models: Use 2" pipe only for the entire length of the vent.

90,000 through 120,000 BTUH models: Install a 2" coupling at the outside wall to prevent the termination from being pushed inward. No reduction of the 2" pipe used to penetrate the wall is necessary. Terminate the 2" PVC exhaust vent at least 12 inches from the outside wall.

FIGURE 13
STANDARD HORIZONTAL DIRECT VENTING
UPFLOW MODEL SHOWN
(TYPICAL FOR DOWNFLOW/HORIZONTAL MODELS)

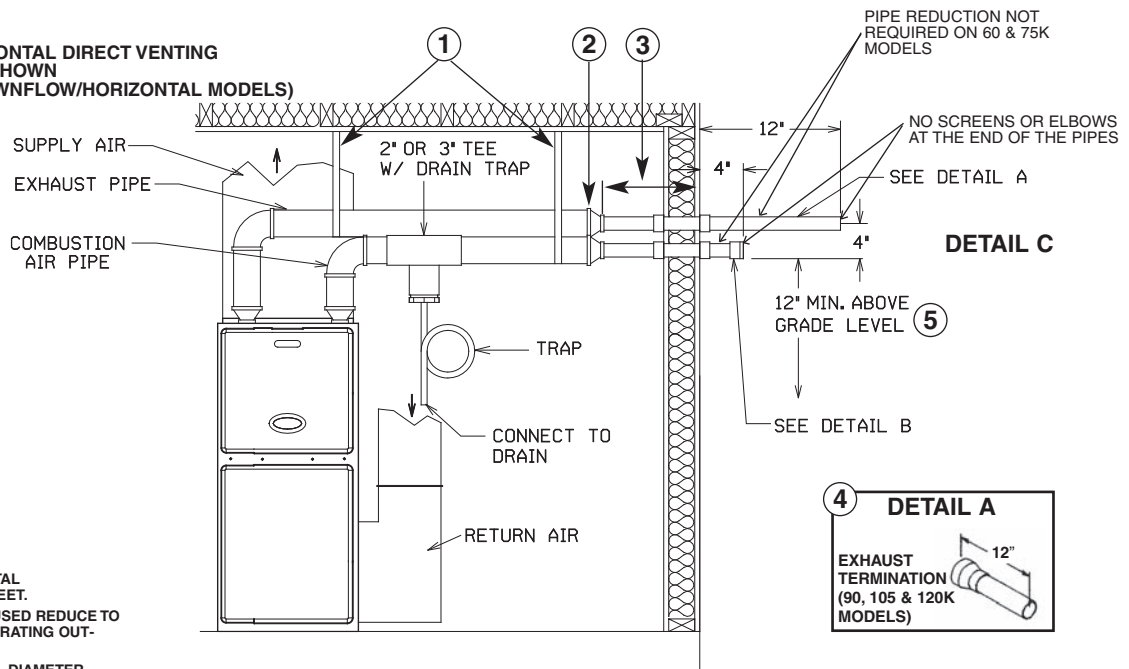

NOTES:

- 1 SUPPORT HORIZONTAL PIPE EVERY FOUR FEET.
- 2 WHEN 3 IN. PIPE IS USED REDUCE TO 2 IN. BEFORE PENETRATING OUTSIDE WALL.
- 3 18 IN. MAXIMUM. 2 IN. DIAMETER PIPE MAY BE USED INSIDE THE WALL.
- 4 DETAIL "A" - EXHAUST TERMINATION TERMINATE THE LAST 12 INCHES WITH 2" PVC PIPE ON 90,000 AND 120,000 BTUH MODELS.
- 5 INCREASE THE 12 IN. MINIMUM ABOVE GRADE TO KEEP TERMINAL OPENINGS ABOVE ANTICIPATED LEVEL OF SNOW ACCUMULATION WHERE APPLICABLE.
- 6 DETAIL "B". INSTALL WIND DEFLECTOR VANE IN 2 IN. PVC COUPLING IN VERTICAL POSITION USING PVC SOLVENT. THE COMBUSTION AIR TERMINATION MUST BE IN THE SAME PRESSURE ZONE AS THE EXHAUST TERMINATION.

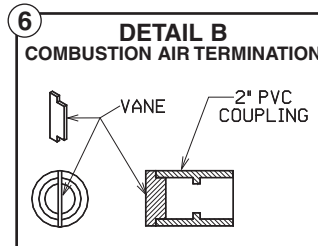
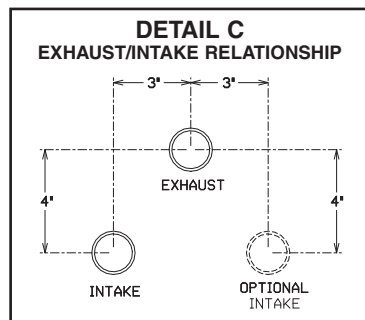

ALTERNATE HORIZONTAL TERMINATIONS (See Figure 14)

NOTE: The combustion air and exhaust terminations must be at least 12 inches above grade or anticipated snow levels. Alternate horizontal terminations allow the combustion air and exhaust terminations to be raised a maximum of 60 inches above the wall penetrations to maintain the required clearance.

NOTE: If combustion air vent pipe is extended more than 24 inches, insulate the vent pipe between the two outside 90° elbows with closed cell insulation such as rubatex, armaflex or equivalent.

NOTE: Ensure the location of the combustion air inlet with respect to the exhaust vent terminal complies with Figure 14.

Combustion Air Piping: Use a 2" PVC elbow with a wind deflector vane (provided) installed as follows:

1. Install a 2" elbow to the combustion air pipe at the outside wall to prevent the termination from being pushed inward.
2. Cut an adequate length of 2" PVC pipe as needed to clear the anticipated snow level and connect this to the elbow.
3. Connect another 2" elbow to the end of the pipe such that the inlet is facing away from the wall. This outer coupling must terminate 4 inches from the wall.
4. Attach the vane in the final 2" elbow in the vertical position with PVC solvent.

IMPORTANT: To insure proper furnace operation, the supplied vane must be installed in the vertical position as shown in Figure 13, Detail B.

FIGURE 14
ALTERNATE HORIZONTAL DIRECT VENT TERMINATION

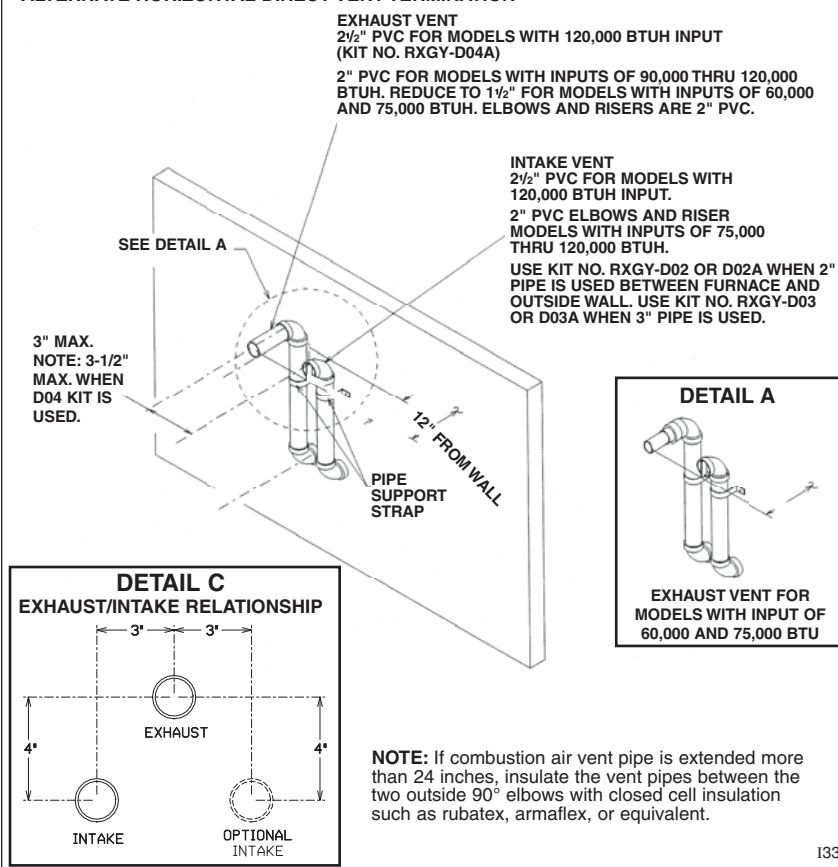

Exhaust Vent Piping:

1. Install a 2" elbow to the exhaust vent pipe at the outside wall to prevent the termination from being pushed inward.
2. Cut an adequate length of 2" PVC pipe as needed to insure proper location of the exhaust vent termination with respect to the combustion air inlet and connect this to the elbow.
3. Connect another 2" elbow to the end of the pipe such that the inlet is facing away from the wall.

Exhaust Vent Termination:

60,000 and 75,000 BTUH models: Use 2" pipe only for the entire length of the vent.

90,000 through 120,000 BTUH models: No reduction of the 2" pipe used to penetrate the wall is necessary. Terminate the 2" PVC exhaust vent at least 12 inches from the outside wall.

120,000 BTUH model with the RXGY-D04A Horizontal Vent Kit: Venting and terminations install the same as above except the 2" pipe and connectors are replaced with 2 1/2" pipe and connectors.

LOCATION REQUIREMENTS HORIZONTAL DIRECT VENTS

▲ CAUTION

THE COMBUSTION PRODUCTS AND MOISTURE IN THE FLUE GASES WILL CONDENSE AS THEY LEAVE THE TERMINATION. THE CONDENSATE CAN FREEZE ON THE EXTERIOR WALL, UNDER THE EAVES AND ON SURROUNDING OBJECTS. SOME DISCOLORATION TO THE EXTERIOR OF THE BUILDING IS TO BE EXPECTED. HOWEVER, IMPROPER LOCATION OR INSTALLATION CAN RESULT IN STRUCTURAL OR EXTERIOR FINISH DAMAGE TO THE BUILDING AND MAY RECIRCULATE PRODUCTS OF COMBUSTION INTO THE COMBUSTION AIR TERMINAL AND FREEZE.

NOTE: In Canada vent terminations must be in accordance with the current CSA-B149 Gas Installation Code and/or local codes.

The vent must be installed with the following minimum clearances. See Figures 15 and 16.

1. Locate the bottom of the vent terminal and the air inlet at least 12 inches above grade. Increase the 12-in. minimum to keep the terminal openings above the level of snow accumulation, where applicable.
2. Do not terminate the vent over public walkways or over an area where condensate or vapor could create a nuisance or hazard.
3. Locate the vent terminal at least one foot from any opening through which flue gases could enter a building.
4. Locate the vent terminal at least 3 feet above any forced air inlet located within 10 feet, except the combustion air inlet of a direct vent appliance.
5. Allow the vent terminal minimum horizontal clearance of 4 feet from electric meters, gas meters, regulators and relief equipment.
6. Locate the furnace combustion air inlet a sufficient distance from the vent of any other gas or fuel burning appliance or electric clothes dryer to prevent recirculation of the flue gases into the furnace combustion air inlet. The only exception to this requirement is the case of multiventing two or more furnaces, which is covered in the section on multiventing in these instructions.

In addition to the minimum clearances listed above, the vent location should be governed by the following guidelines.

1. Do not terminate under any kind of patio or deck. If running the vent under a deck, insulate it to insure no condensate freezes and blocks the pipe. The insulation must be waterproof.
For vent considerations, the edge of the deck must be considered the outside wall.
2. Do not terminate behind any area that may allow the flue products to become stagnant and recirculate.
3. Do not locate on the side of a building with prevailing winter winds. This will help prevent moisture from freezing on walls and overhangs (under eaves).
4. Do not extend vent directly through brick or masonry surfaces. Use a rust-resistant sheet metal or plastic backing plate behind vent. See Figure 7.
5. Do not locate too close to shrubs as condensate may stunt or kill them.

6. Minimum vertical clearances of 1 foot are recommended for overhangs up to 1 foot horizontal. The vertical clearance should be increased equally for each additional increase in horizontal overhang to a maximum vertical clearance of 6 feet.
7. Caulk all cracks, seams and joints within 6 feet horizontally as well as 6 feet above and below vent. See Figure 15.
8. Painted surfaces must be sound and in good condition with no cracking, peeling, etc. Painted surfaces will require maintenance.
9. Do not expose 3" x 2" reducer/bushing to outdoor ambient temperatures.

MULTIVENTING

IF VENTING TWO OR MORE FURNACES NEAR EACH OTHER IS REQUIRED, EACH FURNACE MUST BE INDIVIDUALLY VENTED – NO COMMON VENTING IS PERMITTED. See Figures 17 and 18 for positioning of the terminations. When

**FIGURE 15
MOISTURE ZONES**

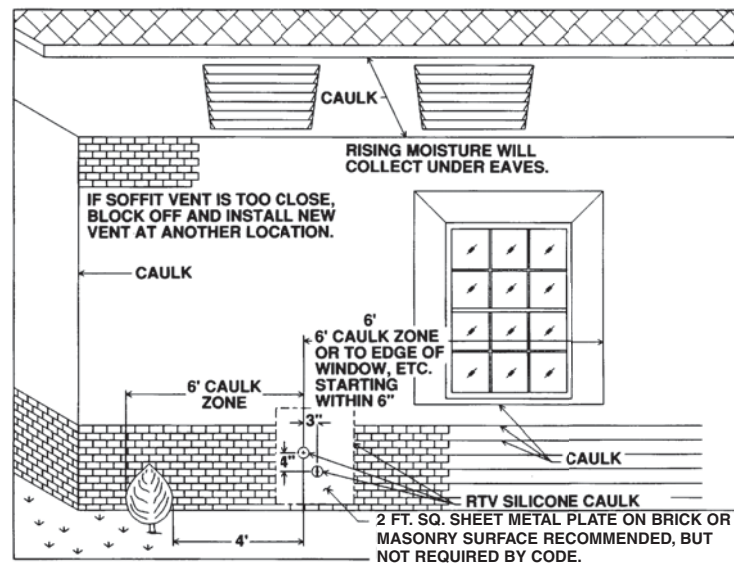
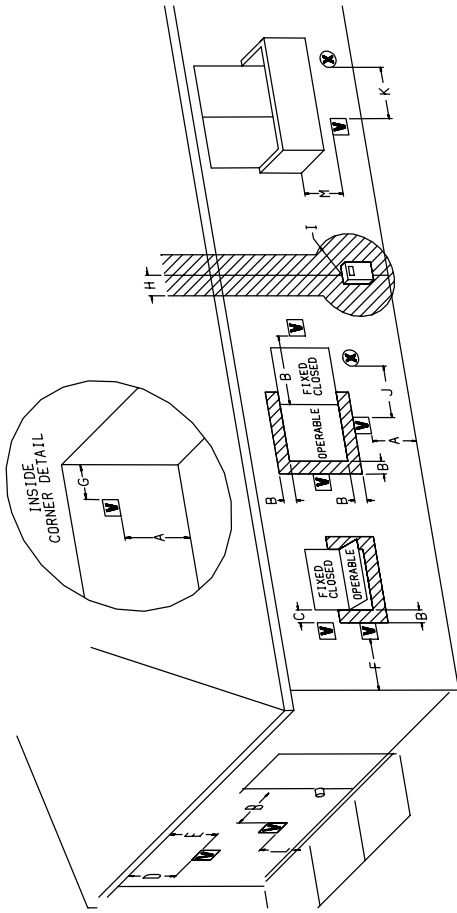

FIGURE 16
DIRECT VENT TERMINAL CLEARANCES



	Canadian Installations ¹	US Installations ²	Canadian Installations ¹	US Installations ²
A=	Clearance above grade, veranda, porch, deck, or balcony	12 inches (30 cm)	6 inches (15 cm) for appliances ≤10,000 BTUH (3 kW), 9 inches (23 cm) for appliances >10,000 BTUH (3 kW) and ≤50,000 BTUH (15 kW), 36 inches (91 cm) for appliances >100,000 BTUH (30 kW)	6 inches (15 cm) for appliances ≤10,000 BTUH (3 kW), 9 inches (23 cm) for appliances >10,000 BTUH (3 kW) and ≤50,000 BTUH (15 kW), 12 inches (30 cm) for appliances >50,000 BTUH (15 kW)
B=	Clearance to window or door that may be opened	6 inches (15 cm) for appliances ≤10,000 BTUH (3 kW), 9 inches (23 cm) for appliances >10,000 BTUH (3 kW) and ≤50,000 BTUH (15 kW), 36 inches (91 cm) for appliances >100,000 BTUH (30 kW)	6 inches (15 cm) for appliances ≤10,000 BTUH (3 kW), 9 inches (23 cm) for appliances >10,000 BTUH (3 kW) and ≤50,000 BTUH (15 kW), 36 inches (91 cm) for appliances >100,000 BTUH (30 kW)	6 inches (15 cm) for appliances ≤10,000 BTUH (3 kW), 9 inches (23 cm) for appliances >10,000 BTUH (3 kW) and ≤50,000 BTUH (15 kW), 36 inches (91 cm) for appliances >100,000 BTUH (30 kW)
C=	Clearance to permanently closed window	*	*	*
D=	Vertical clearance to ventilated soffit located above the terminal within a horizontal distance of 2 feet (61 cm) from the center line of the terminal	*	*	*
E=	Clearance to unventilated soffit	*	*	*
F=	Clearance to outside corner	*	*	*
G=	Clearance to inside corner	*	*	*
H=	Clearance to each side of center line extended above meter/regulator assembly	3 feet (91 cm) within a height 15 feet above the meter/regulator assembly	*	*
I=	Clearance to service regulator vent outlet	3 feet (1.83 m)	*	*
J=	Clearance to nonmechanical air supply inlet to building or the combustion air inlet to any other appliance	6 inches (15 cm) for appliances ≤10,000 BTUH (3 kW), 12 inches (30 cm) for appliances >10,000 BTUH (3 kW) and ≤100,000 BTUH (30 kW), 36 inches (91 cm) for appliances >100,000 BTUH (30 kW)	6 inches (15 cm) for appliances ≤10,000 BTUH (3 kW), 12 inches (30 cm) for appliances >10,000 BTUH (3 kW) and ≤100,000 BTUH (30 kW), 36 inches (91 cm) for appliances >100,000 BTUH (30 kW)	6 inches (15 cm) for appliances ≤10,000 BTUH (3 kW), 9 inches (23 cm) for appliances >10,000 BTUH (3 kW) and ≤50,000 BTUH (15 kW), 12 inches (30 cm) for appliances >50,000 BTUH (15 kW)
K=	Clearance to a mechanical air supply inlet	6 feet (1.83 m)	6 feet (1.83 m)	3 feet (91 cm) above if within 10 feet (3 m) horizontally
L=	Clearance above paved sidewalk or paved driveway located on public property	7 feet (2.13 m) †	7 feet (2.13 m) †	*
M=	Clearance under veranda, porch, deck, or balcony	12 inches (30 cm) ‡	12 inches (30 cm) ‡	*

¹ In accordance with the current CSA B149.1 *Natural Gas and Propane Installation Code*
² In accordance with the current ANSI Z223.1 / NFPA 54 *National Fuel Gas Code*
 † A vent shall not terminate directly above a sidewalk or paved driveway that is located between two single family dwellings and serves both dwellings.
 ‡ Permitted only if veranda, porch, deck, or balcony is fully open on a minimum of two sides beneath the floor.
 * For clearances not specified in ANSI Z223.1 / NFPA 54 or CAN/CGA-B149, one of the following shall be indicated:
 a) A reference to the following footnote:
 "Clearance in accordance with local installation codes, the requirements of the gas supplier and the manufacturer's installation instructions."

FIGURE 17
TWO FURNACE VENTING THROUGH ROOF

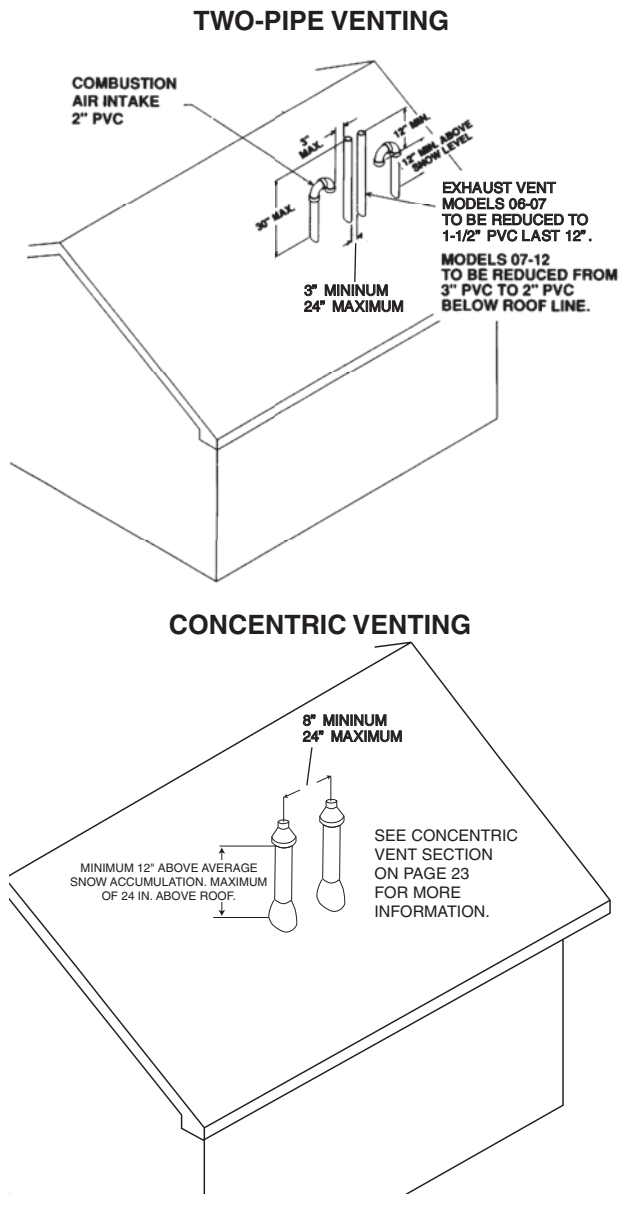
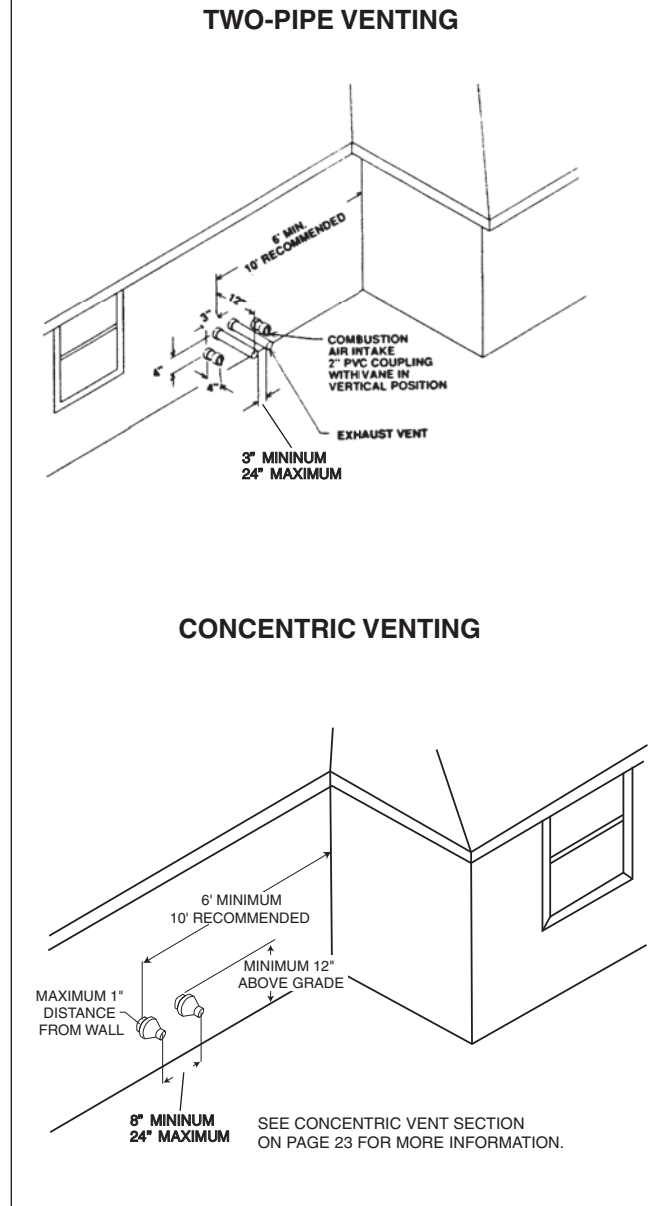

FIGURE 18
TWO FURNACE VENTING THROUGH WALL



more than two furnaces are to be vented, there must be at least 4 feet between the first two furnaces and the third, etc.

CONNECTING TO FURNACE

IMPORTANT: Clean and deburr all pipe cuts. The shavings must not be allowed to block the exhaust, inlet or condensate drain pipes.

IMPORTANT: When indoor combustion air is used, the inlet air opening at the furnace must be protected from accidental blockage. On downflow models, install a double elbow in the top inlet air opening.

UPFLOW MODELS

The exhaust air pipe connection is a 2-in. female PVC pipe fitting extending through the left side of the furnace top plate. See Figure 19. This opening has a protective cap which should be removed just prior to installing the exhaust pipe. When 2-in. pipe is used, connect it directly to this fitting. When 3-in. pipe is used, connect a 2 to 3-in. coupling to this fitting with a short piece of 2-in. PVC pipe.

The inlet combustion air connection is at the right side of the top plate. An alternate combustion inlet air connection may be made on the right side of the jacket. The alternate con-

nection opening has a plastic cap. A combustion inlet air connection fitting is supplied with the furnace and it must be installed in the furnace by screwing it into the opening. Make sure the rubber "O-ring" supplied with the furnace is used with this fitting. See Figure 19.

IMPORTANT: When using indoor combustion air, the furnace air opening must be protected from accidental blockage. Install a 2-inch 90° elbow pointing downward on the side or a double elbow pointing downward in the top opening.

FIGURE 19
UPFLOW COMBUSTION AIR AND VENT PIPE CONNECTION
(GAS VALVE MAY BE DIFFERENT THAN SHOWN)

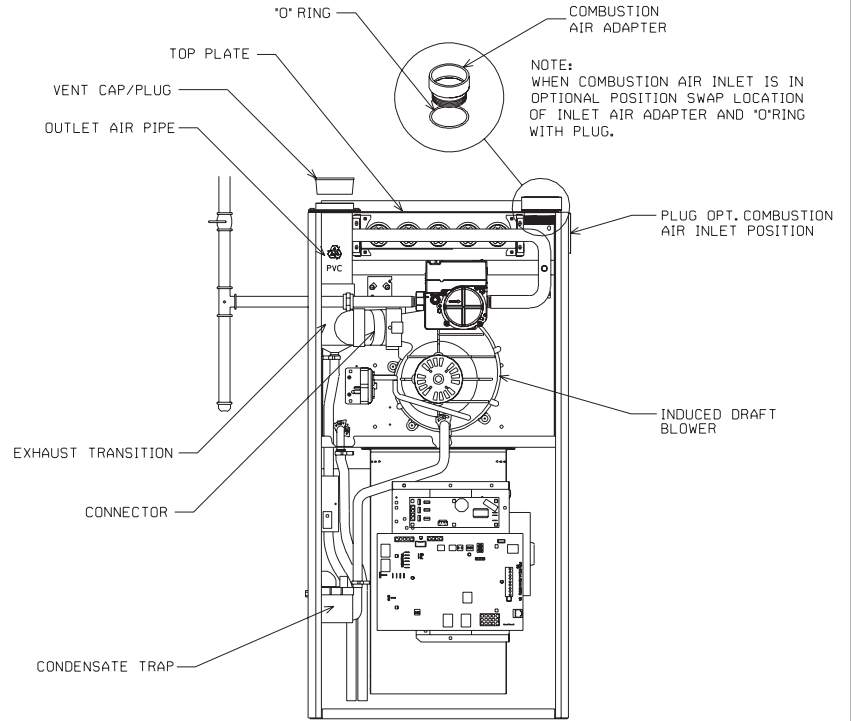

ST-A1157-01

FIGURE 20
UPFLOW MODELS -- COMBUSTION AIR FITTING

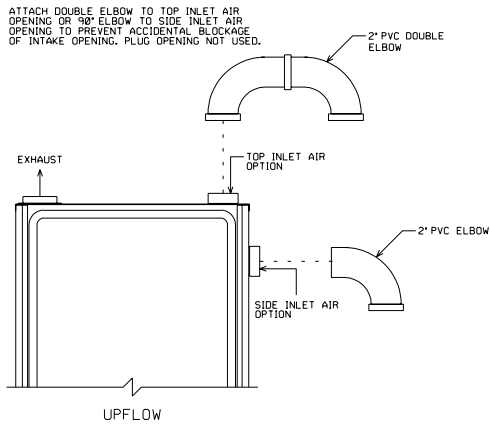

CONDENSATE DRAIN/OPTIONAL NEUTRALIZER

GENERAL INFORMATION

CAUTION

DO NOT RUN DRAIN OUTDOORS. FREEZING OF CONDENSATE CAN CAUSE PROPERTY DAMAGE.

IMPORTANT: Do not connect into a common drain line with an air conditioner evaporator coil drain located below the furnace. A blocked or restricted drain line can result in overflow of the coil pan and negate the furnace blocked-drain shutoff control.

► **IMPORTANT:** If installing the unit over a finished ceiling or living area, be certain to install an auxiliary condensate drain pan under the entire unit extending out under the condensate tee. With the minimum 5½" riser for upflow models or 1¾" for downflow models installed above the tee, a blocked drain will result in overflow from the riser. If the furnace is installed in an attic, crawlspace or other area where freezing temperatures may occur, the furnace drain can freeze while shut off for long periods of time.

If required by local codes, install a condensate neutralizer cartridge in the drain line. Install cartridge in horizontal position only. Also install an overflow line if routing to a floor drain (see Figure 21). If available, install a condensate pump that is resistant to acidic water. Pumps are available from your local distributor. If pump used is not resistant to acidic water, a condensate neutralizer must be used ahead of the pump. The condensate pump must have an auxiliary safety switch to prevent operation of the furnace and resulting overflow of condensate in the event of pump failure. The safety switch must be wired through the "R" circuit only (low voltage) to provide operation in either heating or cooling modes.

When selecting neutralizer cartridges and condensate pumps, use the following data:

CONDENSATE PRODUCTION:

MAX (ALL MODELS) = 1-2 gallons per hr.

pH LEVEL:

3.2 - 4.5 using OUTDOOR air
2.2 - 4.5 using INDOOR air
(neutral pH = 7.0)

UPFLOW MODELS

The condensate drain trap is located in the blower compartment on the left-hand side of the jacket. A short piece of ½-in. PVC pipe and a ½-in. tee are provided. Connect the ½-in. pipe to the elbow on the trap and the tee to this pipe so that the open end is upward. Run a drain tube from the bottom of the tee to a floor drain or condensate pump.

IMPORTANT: If installing the unit over a finished ceiling or living area, be certain to install an auxiliary condensate drain pan under the entire unit extending out under the condensate tee.

FIGURE 21
UPFLOW CONDENSATE DRAIN
(GAS VALVE MAY BE DIFFERENT THAN SHOWN)

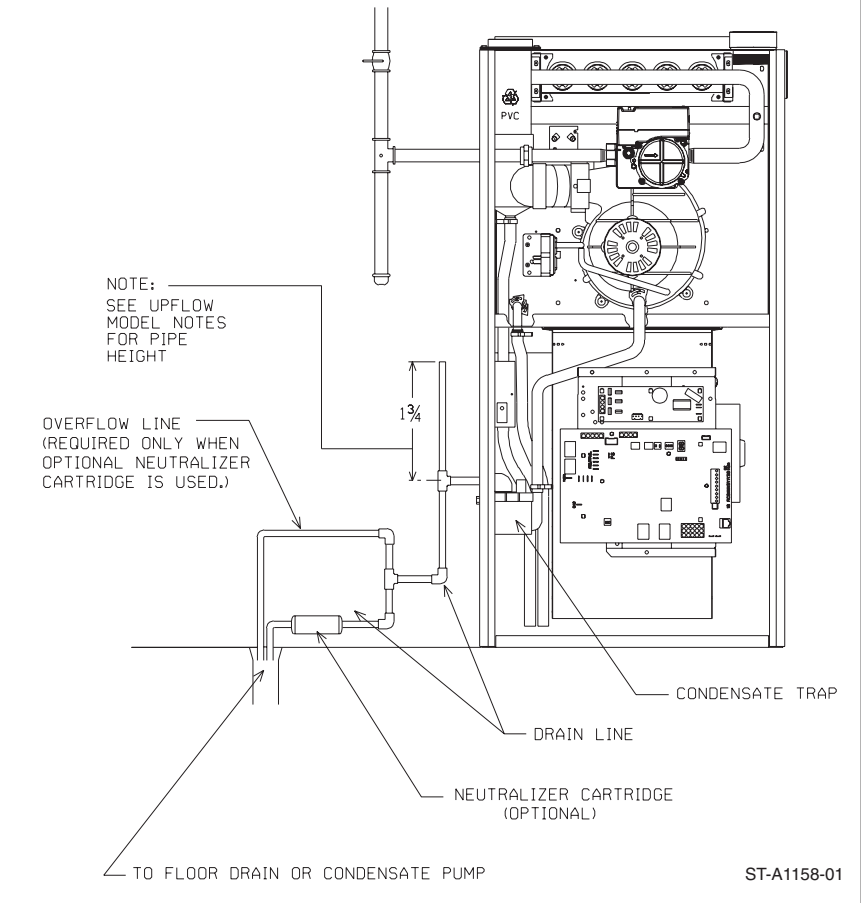

ST-A1158-01

IMPORTANT: There are two options when choosing a height for the condensate riser:

CONDENSATE OVERFLOW: With a $5\frac{1}{2}$ inch riser installed above the tee, a blocked drain will result in overflow from the riser.

FURNACE SHUTDOWN: To cause the furnace to shut down when a blocked drain is present, install a riser which is a minimum of $10\frac{13}{16}$ ". If the furnace is installed in an attic, crawlspace or other area where freezing temperatures may occur, the furnace drain can freeze while shut off for long periods of time.

Use a solvent cement that is compatible with PVC material. Cut the drain hoses to the appropriate length and connect to the trap with hose clamps. Tighten the clamps with pliers and check for leaks after attaching.

REVERSING THE TRAP UPFLOW MODELS

The trap may be moved to the right side for right-side drainage. Open the knockout for the drain on the right side of the cabinet. Remove the bracket holding the trap from the left side. Seal the left side drain hole with a plug provided in the cloth bag with the furnace. Position the mounting bracket and trap so that the drain elbow is centered in the hole on the right. See Figure 22.

Drill two holes in the cabinet to mount the bracket. Mount the trap and bracket to the right side with the drain elbow pointing through the knockout. Connect the $\frac{1}{2}$ " pipe and tee as noted above. Route the drain hoses behind the top of the electric box, cut to the appropriate length, and connect to the trap with hose clamps.

IMPORTANT: Do not connect into a common drain line with an air conditioner evaporator coil drain located above the furnace. A blocked or restricted drain line can result in overflow of the coil pan and negate the furnace blocked drain shutoff control.

FIGURE 22
UPFLOW OPPOSITE SIDE CONDENSATE TRAP CONNECTION
(NO KIT REQUIRED)

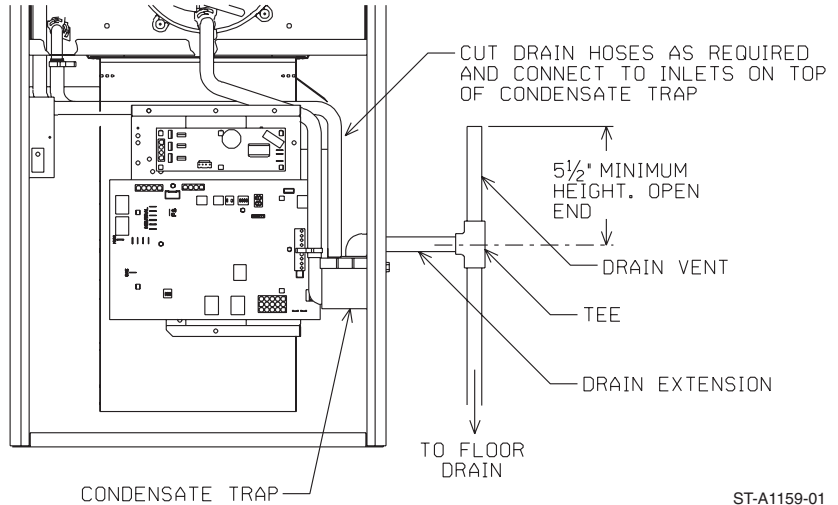

ST-A1159-01

GAS SUPPLY AND PIPING

GAS SUPPLY

▲ WARNING

THIS FURNACE IS EQUIPPED AT THE FACTORY FOR USE ON NATURAL GAS ONLY. CONVERSION TO LP GAS REQUIRES A SPECIAL KIT AVAILABLE FROM THE DISTRIBUTOR. FAILURE TO USE THE PROPER CONVERSION KIT CAN CAUSE FIRE, CARBON MONOXIDE POISONING, EXPLOSION, PROPERTY DAMAGE, PERSONAL INJURY OR DEATH.

See the conversion kit index supplied with the furnace. This index identifies the proper LP Gas Conversion Kit required for each particular furnace.

IMPORTANT: Any additions, changes or conversions required for the furnace to satisfactorily meet the application should be made by a qualified installer, service agency or the gas supplier, using factory-specified or approved parts.

IMPORTANT: Connect this furnace only to gas supplied by a commercial utility.

IMPORTANT: A U.L. recognized fuel gas and CO detector(s) are recommended in all applications, and their installation should be in accordance with the manufacturer's recommendations and/or local laws, rules, regulations or customs.

GAS PIPING

Install the gas piping according to all local codes and regulations of the utility company.

If possible, run a separate gas supply line directly from the meter to the furnace. Consult the local gas company for the location of the manual main shut-off valve. **The gas line and manual gas valve must be adequate in size to prevent undue pressure drop and never smaller than the pipe size**

FIGURE 23
GAS PIPING -- UPFLOW INSTALLATION
(GAS VALVE MAY BE DIFFERENT THAN SHOWN)

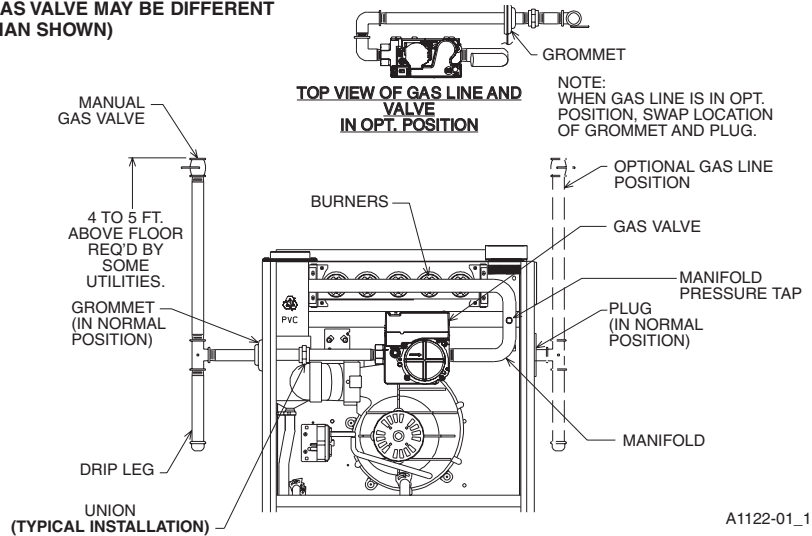

IMPORTANT: Do not run a flexible gas connector inside the unit.

to the combination gas valve on the furnace. Refer to Table 9 for the recommended gas pipe size for natural gas and Table 10 for L.P. See Figure 23 for typical gas pipe connections.

Install a ground joint union between the manual gas stop and the main gas valve to easily remove the control valve assembly. Install a manual gas stop in the gas line outside the furnace cabinet. The gas stop should be readily accessible to turn the gas supply on or off. Install a drip leg in the gas supply line as close to the furnace as possible. Always use a pipe compound resistant to the action of liquefied petroleum gases on all threaded connections.

IMPORTANT: When making gas pipe connections, use a back-up wrench to prevent any twisting of the control assembly and gas valve.

Any strains on the gas valve can change the position of the gas orifices in the burners. This can cause erratic furnace operation.

IMPORTANT: Do not run a flexible gas connector inside the unit. If local codes allow the use of a flexible gas appliance connector, always use a new listed connector. Do not use a connector which has previously serviced another gas appliance. Massachusetts law requires that all flexible gas connectors be less than 36".

The gas pipe grommet in the cabinet does not seal around a flexible gas connector. **It is important to have all openings in the cabinet burner compartment sealed for proper furnace operation.**

IMPORTANT: To insure a good seal, the gas pipe that runs through the grommet must be 1/2" schedule 40 black pipe.

IMPORTANT: Ensure that the furnace gas control valve is not subjected to high gas line supply pressures (13.5" w.c. or above).

DISCONNECT the furnace and its individual shut-off valve from the gas supply piping during **any pressure testing that exceeds 1/2 PSIG (3.23 kPa or 13" w.c.).**

GAS PRESSURE

Natural gas supply pressure should be 5" to 10.5" w.c. LP gas supply pressure should be 11" to 13" w.c. This pressure must be maintained with all other gas-fired appliances in operation.

▲ WARNING

NEVER PURGE A GAS LINE INTO THE COMBUSTION CHAMBER. NEVER USE MATCHES, FLAME OR ANY IGNITION SOURCE FOR CHECKING LEAKAGE. FAILURE TO ADHERE TO THIS WARNING CAN CAUSE A FIRE OR EXPLOSION RESULTING IN PROPERTY DAMAGE, PERSONAL INJURY OR DEATH.

To check for gas leakage, use an approved chloride-free soap and water solution, an electronic combustible gas detector, or other approved method.

GAS VALVE

This furnace has a 24-volt operated main solenoid valve. It has ports for measuring supply pressure and manifold pressure. A manual control is on the valve body. It can be set to only the "ON" or "OFF" positions.

See Figure 24.

▲ WARNING

FOR MODULATING FURNACES WITH THE STEPPER/SERVO CONTROLLED MODULATING VALVE, DO NOT ROUTE THE SPARK IGNITOR WIRE (ORANGE) NEAR THE GAS VALVE. DOING SO COULD RESULT IN A LOSS OF HEAT.

FIGURE 24
GAS VALVE
STEPPER CONTROL-FUEL CODE HA
OR HB

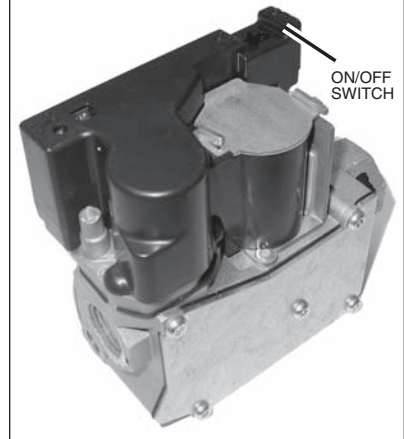

TABLE 9**NATURAL GAS PIPE CAPACITY TABLE (CU. FT./HR.)**

Capacity of gas pipe of different diameters and lengths in cu. ft. per hr. with pressure drop of 0.3 in. and specific gravity of 0.60 (natural gas).

Nominal Iron Pipe Size, Inches	Length of Pipe, Feet							
	10	20	30	40	50	60	70	80
1/2	132	92	73	63	56	50	46	43
3/4	278	190	152	130	115	105	96	90
1	520	350	285	245	215	195	180	170
1-1/4	1,050	730	590	500	440	400	370	350
1-1/2	1,600	1,100	890	760	670	610	560	530

After the length of pipe has been determined, select the pipe size which will provide the minimum cubic feet per hour required for the gas input rating of the furnace. By formula:

$$\text{Cu. Ft. Per Hr. Required} = \frac{\text{Gas Input of Furnace (BTU/HR)}}{\text{Heating Value of Gas (BTU/FT}^3\text{)}}$$

The gas input of the furnace is marked on the furnace rating plate. The heating value of the gas (BTU/FT³) may be determined by consulting the local natural gas utility or the LP gas supplier.

TABLE 10**LP GAS PIPE CAPACITY TABLE (CU. FT./HR.)**

Maximum capacity of pipe in thousands of BTU per hour of undiluted liquefied petroleum gases (at 11 inches water column inlet pressure).

(Based on a Pressure Drop of 0.5 Inch Water Column)

Nominal Iron Pipe Size, Inches	Length of Pipe, Feet											
	10	20	30	40	50	60	70	80	90	100	125	150
1/2	275	189	152	129	114	103	96	89	83	78	69	63
3/4	567	393	315	267	237	217	196	182	173	162	146	132
1	1,071	732	590	504	448	409	378	346	322	307	275	252
1-1/4	2,205	1,496	1,212	1,039	913	834	771	724	677	630	567	511
1-1/2	3,307	2,299	1,858	1,559	1,417	1,275	1,181	1,086	1,023	976	866	787
2	6,221	4,331	3,465	2,992	2,646	2,394	2,205	2,047	1,921	1,811	1,606	1,496

Example (LP): Input BTU requirement of unit, 150,000
Equivalent length of pipe, 60 ft. = 3/4" IPS required.

LP COPPER TUBE SIZING TABLE

Sizing between single or second stage (low pressure) regulator and appliance. Maximum capacity of pipe in thousands of BTU per hour of undiluted propane gases (at 11" w.c. setting).

Outside Diameter Copper Tubing, Type L	Length of Pipe, Feet										
	10	20	30	40	50	60	80	100	125	150	
3/8"	49	34	27	23	20	19	16	14	11	10	
1/2"	110	76	61	52	46	42	36	32	28	26	
5/8"	206	141	114	97	86	78	67	59	52	48	
3/4"	348	239	192	164	146	132	113	100	89	80	
7/8"	536	368	296	253	224	203	174	154	137	124	

LP CONVERSION

IMPORTANT: LP gas from trucks used to transport liquid-based fertilizers can contain chemicals that will damage the furnace. Verify that your gas supplier does not use the same truck to transport materials other than LP.

This furnace is shipped from the factory for use on natural gas only. For use on LP gas, a proper conversion is required.

Conversion of the furnace for use with LP gas requires conversion kit **RXGJ-FP27**. (Gas valve not required.)

⚠ CAUTION

ELEVATIONS ABOVE 2000 FT REQUIRE THAT THE FURNACE INPUT RATING BE ADJUSTED AND THAT THE SIZE OF THE BURNER ORIFICES BE RE-CALCULATED BASED ON ELEVATION AND GAS HEATING VALUE. THE BURNER ORIFICES MAY (OR MAY NOT) NEED TO BE CHANGED. SEE THE SECTION TITLED “HIGH ALTITUDE INSTALLATIONS” OF THIS BOOK FOR INSTRUCTIONS.

High altitude installations above 5,000 feet are not permitted with RGFG furnace models.

NOTE: Order the correct LP conversion kit available from the local distributor. *Furnace conversion to LP gas must be performed by a qualified installer, service agency, or the gas supplier.*

To change orifice spuds for conversion to LP:

1. Shut off the manual gas valve and disconnect the gas line at the union ahead of the unit gas valve.
2. Remove the gas valve and manifold assembly.
3. Replace the orifice spuds.
4. For servo (stepper) controlled gas valve (fuel code HA or HB): Install the jumper supplied with the kit into the valve as shown in Figures 25 and 27. Make sure that the jumper connects the two pins and verify by checking manifold pressure at high fire. It should be approx. 11" w.c.
5. Re-attach the manifold assembly to the unit and connect the gas line to the gas valve.
6. Place the conversion label, included in the kit, adjacent to the CSA rating plate. Also for servo controlled gas valves only (fuel code HA or HB) be sure to install the label titled “LP” over the hole where the jumper is inserted in Item 4 above.

7. Check unit for leaks.
 8. Follow lighting instructions to put the furnace into operation.
 9. Check manifold pressure.
- Consult Tables 13 (U.S.) and 14 (Canada), if there is any question concerning orifice sizing.

NOTE: LP orifices are included in the kit but they may need to be exchanged based on heating value and/or elevation. LP orifices must be selected based on the altitude of the installation. See orifice chart.

NOTE ABOUT LP CONVERSION OF STEPPER-CONTROLLED MODULATING GAS VALVE:

To convert the stepper-controlled modulating gas valve, a jumper is required to connect the two pins inside the jumper well. It is possible to install the jumper such that the pins are not connected. This is incorrect. The jumper must connect the pins together inside the jumper well. This can be confirmed by visual inspection and by verifying proper manifold pressure at high fire (100%) after the jumper is installed. Manifold pressure should always be checked by the installer when converting the furnace for LP operation. Figures 26 and 27 below show the incorrect way and the correct way to install the jumper. The jumper well is located next to the adjustment well (with “+” and “-” text and two-headed arrow) and will be covered by a sticker or label. To convert to LP the label over the jumper well will need to be removed.

FIGURE 25

SERVO CONTROLLED GAS VALVE SUPPLY PRESSURE TAP AND LP JUMPER WELL

NOTE: REMOVE COVER TO ADJUSTMENT WELL WHEN MAKING ADJUSTMENTS. REPLACE WHEN DONE.

NOTE: THE ADJUSTMENT WHEEL WILL NOT STOP ROTATING WHEN IT HITS THE MAXIMUM OR MINIMUM POSITION. INSTEAD IT WILL CONTINUE TO ROTATE TO THE OPPOSITE ADJUSTMENT. USE THE LETTERS ON THE WHEEL AS A GUIDE.

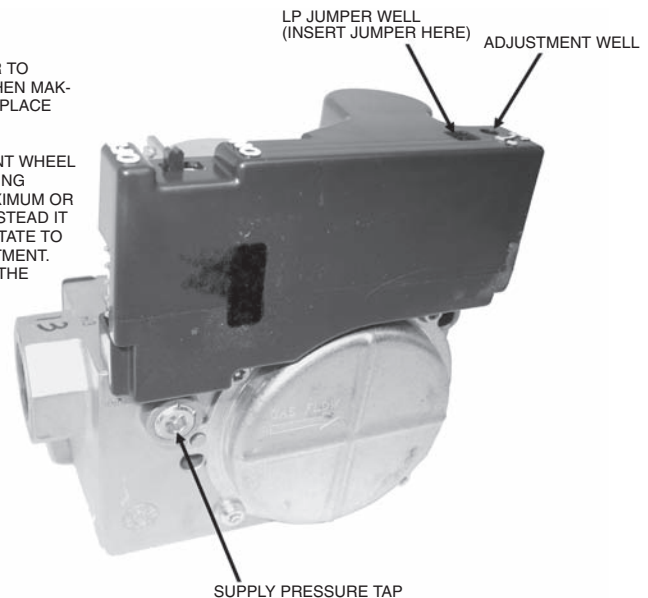

FIGURE 26

LP JUMPER INSTALLED ON SERVO MODULATING GAS VALVE WITH PINS NOT CONNECTED. THIS IS **INCORRECT**. MAKE SURE THAT THE JUMPER CONNECTS THE TWO PINS TOGETHER AND VERIFY MANIFOLD GAS PRESSURE AT HIGH FIRE TO MAKE SURE THE VALVE IS PROPERLY CONVERTED FOR LP GAS

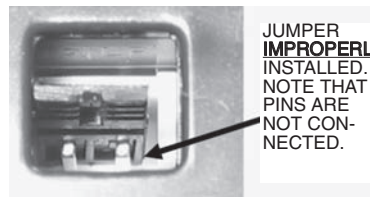
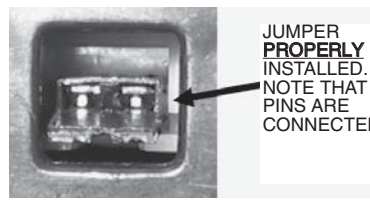

FIGURE 27

LP JUMPER INSTALLED ON SERVO MODULATING GAS VALVE WITH PINS PROPERLY CONNECTED. THIS IS **CORRECT**. MAKE SURE THAT THE JUMPER CONNECTS THE TWO PINS TOGETHER AND VERIFY MANIFOLD GAS PRESSURE AT HIGH FIRE TO MAKE SURE THAT THE VALVE IS PROPERLY CONVERTED FOR LP GAS



SETTING GAS PRESSURE

A properly calibrated pressure gauge or U-Tube manometer is required for accurate gas pressure measurements.

▲ CAUTION

ELEVATIONS ABOVE 2000 FT REQUIRE THAT THE FURNACE INPUT RATING BE ADJUSTED AND THAT THE SIZE OF THE BURNER ORIFICES BE RE-CALCULATED BASED ON ELEVATION AND GAS HEATING VALUE. THE BURNER ORI-

FICES MAY (OR MAY NOT) NEED TO BE CHANGED. SEE THE SECTION TITLED "HIGH ALTITUDE INSTALLATIONS" OF THIS BOOK FOR INSTRUCTIONS.

Supply Gas Pressure Measurement.

1. With gas shut off to the furnace at the manual gas valve outside the unit, remove the line pressure tap plug on the gas valve. See Figure 25.
2. Connect a U-Tube manometer to the pressure tap.
3. Turn on the gas supply and operate the furnace at 100% and all other gas-fired units on the same gas line as the furnace.
4. Note or adjust the supply-line pressure to give:
 - A. 5" - 10.5" w.c. for natural gas.
 - B. 11" - 13" w.c. for LP gas.
5. Shut off the gas at the manual gas valve and remove the U-Tube manometer.
6. Replace the supply-line pressure tap plug before turning on the gas.
7. Check unit for leaks.

If the supply-line pressure is above these ranges, install an in-line gas regulator to the furnace for natural gas units. With LP gas, have the LP supplier reduce the supply-line pressure at the regulator.

If supply-line pressure is below these ranges, either remove any restrictions in the gas supply piping or enlarge the gas pipe. See Tables 9 and 10. With LP gas, have the LP supplier adjust the supply-line pressure at the regulator.

▲ CAUTION

ELEVATIONS ABOVE 2000 FT REQUIRE THAT THE FURNACE INPUT RATING BE ADJUSTED AND THAT THE SIZE OF THE BURNER ORIFICES BE RE-CALCULATED BASED ON ELEVATION AND GAS HEATING VALUE. THE BURNER ORIFICES MAY (OR MAY NOT) NEED TO BE CHANGED. SEE THE SECTION TITLED "HIGH ALTITUDE INSTALLATIONS" OF THIS BOOK FOR INSTRUCTIONS.

► SERVO GAS VALVE (FUEL CODE: HA OR HB) MANIFOLD GAS PRESSURE MEASUREMENT/ADJUSTMENT.

1. With the gas to the unit shut off at the manual gas valve, remove the outlet pressure tap plug in the gas valve. See Figure 28.
2. Connect the positive pressure hose from a manometer to the pressure tap.
3. Note the manifold gas pressure to be:
 - A. 3.5" w.c. (± 3) for natural gas .
 - B. 10.0" w.c. (± 5) for LP gas.
4. To adjust the pressure regulator, insert a small slotted screwdriver into the opening at the top of the valve.

NOTE: Only small variations in gas pressure should be made by adjusting the pressure regulator.

NOTE: Allow up to 5 seconds for each change in manifold pressure.
5. Turn the adjustment screw clockwise to increase pressure, or counterclockwise to decrease pressure.
6. Check manifold gas pressure.
7. Repeat step 5 & 6 if needed.
8. Securely replace the regulator cap.

NOTE: Shut off gas at the manual gas valve and remove the U-Tube manometer.
9. Replace the manifold pressure tap plug before turning on the gas.
10. Check unit for leaks.

NOTE: Do not use gas valve pressure adjustment as a means to adjust temperature rise. The blower motor will change speed to maintain a reasonably constant temperature rise.

FIGURE 28

SERVO-CONTROLLED GAS VALVE MANIFOLD PRESSURE TAP LOCATION

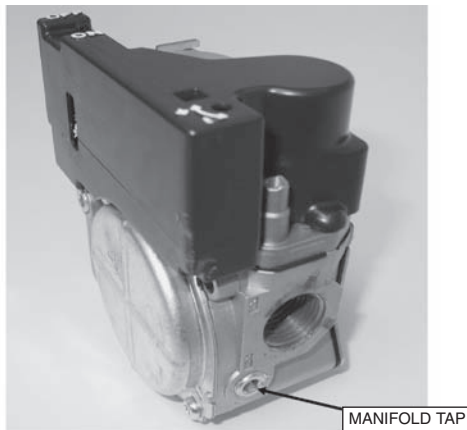

ELECTRICAL WIRING

▲ WARNING

TURN OFF ELECTRIC POWER AT FUSE BOX OR SERVICE PANEL BEFORE MAKING ANY ELECTRICAL CONNECTIONS. FAILURE TO DO SO CAN CAUSE ELECTRICAL SHOCK RESULTING IN PERSONAL INJURY OR DEATH.

▲ WARNING

THE CABINET MUST HAVE AN UNINTERRUPTED GROUND ACCORDING TO THE LATEST EDITION OF THE NATIONAL ELECTRICAL CODE, ANSI/NFPA70-, OR IN CANADA, THE CANADIAN ELECTRICAL CODE, CSA-C22.1 OR LOCAL CODES THAT APPLY. A GROUND SCREW IS PROVIDED IN THE JUNCTION BOX. FAILURE TO PROPERLY CONNECT THE GROUND WIRE CAN CAUSE ELECTRICAL SHOCK RESULTING IN PERSONAL INJURY OR DEATH.

▲ WARNING

THIS FURNACE IS EQUIPPED WITH A BLOWER DOOR SAFETY SWITCH. DO NOT DISABLE THIS SWITCH. FAILURE TO FOLLOW THIS WARNING CAN RESULT IN ELECTRICAL SHOCK, PERSONAL INJURY OR DEATH.

IMPORTANT: The furnace must be installed so that the electrical components are protected from water.

A grounding wire is provided to connect to the incoming grounding wire from line power. The furnace must be permanently grounded in accordance with all national and local codes.

Before proceeding with the electrical connections, be certain that the service panel voltage, frequency and phase corresponds to that specified on the furnace rating plate. Maximum over-current protection is 15 amperes.

Use a separate, fused branch electrical circuit containing a properly sized fuse or circuit breaker. Connect this circuit directly from the main switch box to an electrical disconnect that is readily accessible and located within arm's reach (2 ft.) of the furnace. Connect from the electrical disconnect to the junction box on the left side of the furnace, inside the blower compartment. See Figure 29. For the proper connection, refer to the appropri-

ate wiring diagram located on the inside cover of the furnace control box and in these instructions.

NOTE: The electrical junction box may be moved to the right side if necessary. A knockout is provided. Seal the opposite hole with plug provided.

▲ WARNING

L1 TERMINAL AND NEUTRAL TERMINAL POLARITY MUST BE OBSERVED WHEN MAKING FIELD CONNECTIONS TO THE FURNACE. FAILURE TO DO SO WILL EXPOSE LIVE WIRING IN THE BLOWER COMPARTMENT WHEN THE DOOR IS REMOVED. TOUCHING THESE LIVE CIRCUITS COULD RESULT IN PERMANENT INJURY OR DEATH FROM ELECTRICAL SHOCK.

Make all electrical connections in accordance with the latest edition of the National Electrical Code ANSI/NFPA70 – or in Canada, the Canadian Electrical Code Part 1- CSA Standard C22.1 and local codes having jurisdiction.

These may be obtained from:

National Fire Protection Association, Inc.
Batterymarch Park
Quincy, MA 02269

Canadian Standards Association
178 Rexdale Boulevard
Rexdale, Ontario, Canada M9W 1R3

FIGURE 29
JUNCTION BOX LOCATION

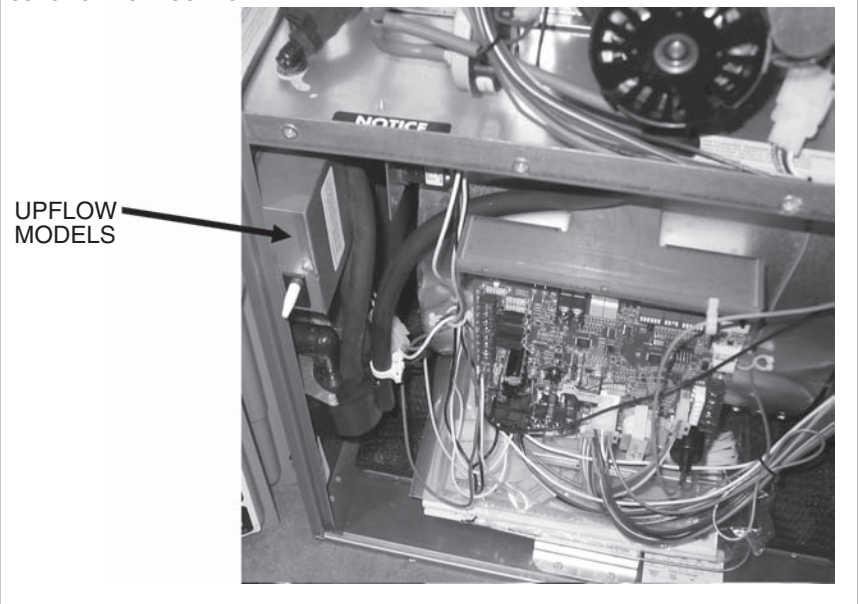

ELECTRICAL CHECKS

Line Power Check

The furnace must have a nominal 115 volt power supply for proper operation. If there is not a consistent power supply, contact a licensed electrician to correct the problem.

1. With the blower compartment door off, manually hold the push button door switch in.
2. Call for heat at the thermostat.
3. With the unit operating, use a voltmeter to measure the voltage from any 120 VAC terminal to any neutral connection.
4. The voltage should be a nominal 115 volts (acceptable 105-120VAC).

This test should be made with the unit in full operation.

Polarity Check

If line & neutral are reversed, a fault code (26) will be displayed at the furnace seven segment display (SSD) and at the communicating thermostat active fault display screen (communicating systems only).

Proper line voltage polarity, or phasing, is a must for this furnace to operate. Use a volt meter to make this check.

1. With the blower compartment door off, manually hold the push button door switch in.
2. Use a voltmeter to measure the voltage from any 120 VAC terminal to any bare metal ground on the furnace.
3. The voltage should be a nominal 115 volts (acceptable 105-120VAC).
4. Use a voltmeter to measure the voltage from any neutral terminal to the bare metal ground on the furnace.
5. The voltage should be less than 1.0 VAC.
6. If the voltage from any 120 VAC terminal to ground is less than 1.0 VAC volts and the voltage from a neutral to ground is a nominal 115 volts, the polarity is reversed.
7. To correct the problem, either reverse the hot and neutral wires to the furnace or have a licensed electrician check the building wiring.

Control Voltage Check

1. With the blower compartment door off, manually hold the push button door switch in.
2. Call for heat at the thermostat. (Does not include communicating thermostats.)

3. With the unit operating, use a voltmeter to measure the voltage from control voltage terminal "W" to terminal "C" on the furnace control board.
4. The voltage should be a nominal 24 volts (Acceptable 18-30 VAC).

This test should be made with the unit in full operation.

ACCESSORIES

FIELD-INSTALLED OPTION ACCESSORIES

TWINNING: Twinning is **NOT** permitted on any modulating furnace model.

ELECTRONIC AIR CLEANER

Line voltage power is supplied from the terminal "EAC", see Figure 30, and a neutral terminal on the control board. This will power the electronic air cleaner whenever the blower is operating and delivering the recommended minimum CFM. The 60 and 75 KBTU models, which are capable of a maximum delivery of 1200 CFM, will operate the electronic air cleaner at 500 CFM and above. The 90, 105 and 120 KBTU models, which are capable of a maximum delivery of 2000 CFM, will operate the electronic air cleaner at 800 CFM and above. These limits are set to prevent excessive production of ozone at the lower airflows of the modulating furnace and are based on average requirements of commercially available electronic air cleaners.

Continuous fan speeds are selectable and some lower fan speeds may not deliver enough airflow to operate an electronic air cleaner. The IFC determines the minimum airflow necessary to operate an electronic air cleaner and will not turn on the electronic air cleaner unless the airflow is high enough for the EAC.

The electronic air cleaner will not be energized until 20-30 seconds after the main blower has been energized.

HUMIDIFICATION AND DEHUMIDIFICATION

Note: The humidifier output will be energized briefly during a heat call while the igniter is on (igniter warm-up period) even when there is no demand for humidification.

HUMIDIFIER – The humidifier contacts (labeled "HUM OUT") are "dry" contacts

FIGURE 30
EAC AND HUMIDIFIER TERMINALS ON FURNACE CONTROL (IFC)

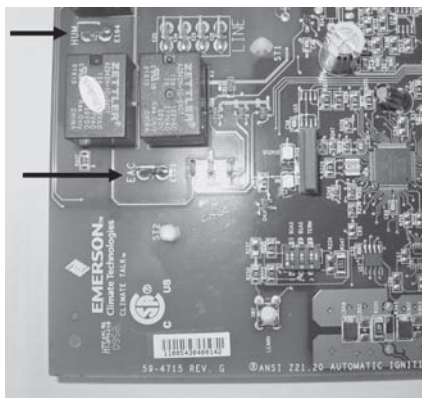

on the I.F.C. This means that the terminals are connected directly to the contacts of a board-mounted relay. The coil of the relay is controlled by the micro-processor of the IFC. The coil is engaged roughly any time the heat speed blower is engaged and (1) 24VAC is present on the thermostat terminal of the IFC labeled "HUM STAT" or (2) a communicating thermostat with humidification and dehumidification capability is installed with call for humidification present.

An optional 24VAC humidistat can be installed as shown in Figures 31 thru 34

(II thru IV). With the optional humidistat, two separate conditions must be met before humidification can begin 1). There must be a call for heat and the blower must be engaged and 2.) The humidistat must determine that there is a need for humidification.

Note: Dipswitch S5-1 enables ("ON") or disables ("OFF") dehumidification operation. However, it has no effect on humidification operation. If this switch is set to the "ON" position and no humidistat is installed, the cooling airflow will be

FIGURE 31
WIRING FOR OPTIONAL HUMIDIFICATION (AND DEHUMIDIFICATION WITH COMMUNICATING THERMOSTAT) WITH OPTIONAL HUMIDIFIER AND NO HUMIDISTAT (HUMIDIFICATION ACTIVE DURING ANY HEAT CALL) (FOR USE WITH COMMUNICATING AND NON-COMMUNICATING THERMOSTATS)

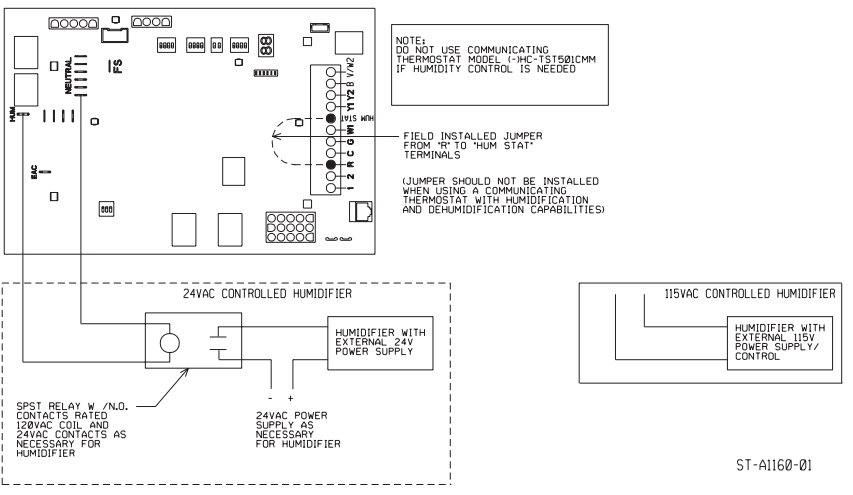

FIGURE 32
WIRING FOR OPTIONAL DEHUMIDIFICATION WITH HUMIDIFICATION (WITH OPTIONAL HUMIDISTAT AND HUMIDIFIER)
NOTE: CAN BE USED WITH COMMUNICATING OR NON-COMMUNICATING SYSTEMS

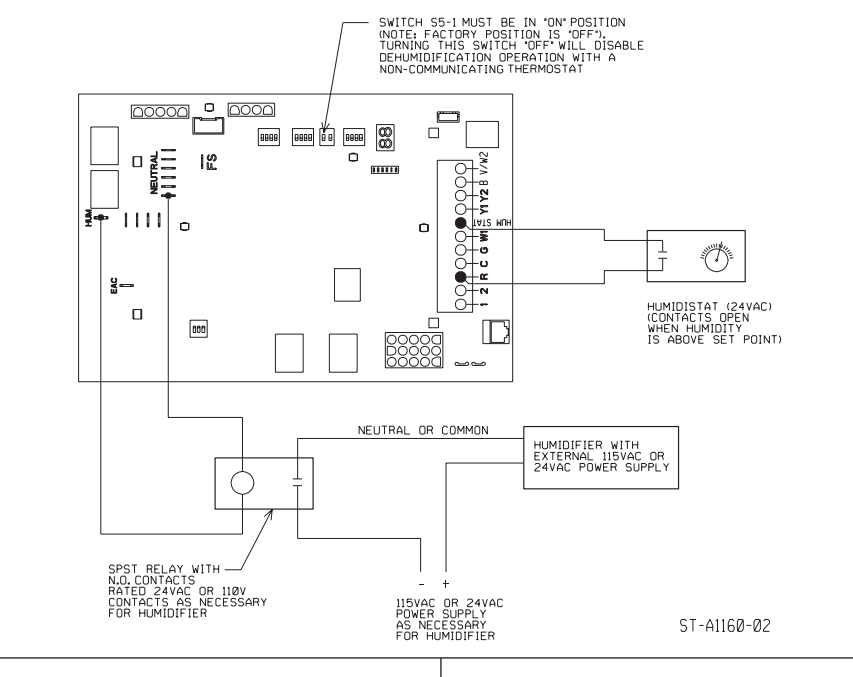

FIGURE 33
WIRING FOR OPTIONAL DEHUMIDIFICATION OPERATION AND HUMIDIFICATION WITH OPTIONAL HUMIDIFIER (HUMIDIFIER WITH INTERNAL POWER SUPPLY) (FOR USE WITH NON-COMMUNICATING THERMOSTATS)

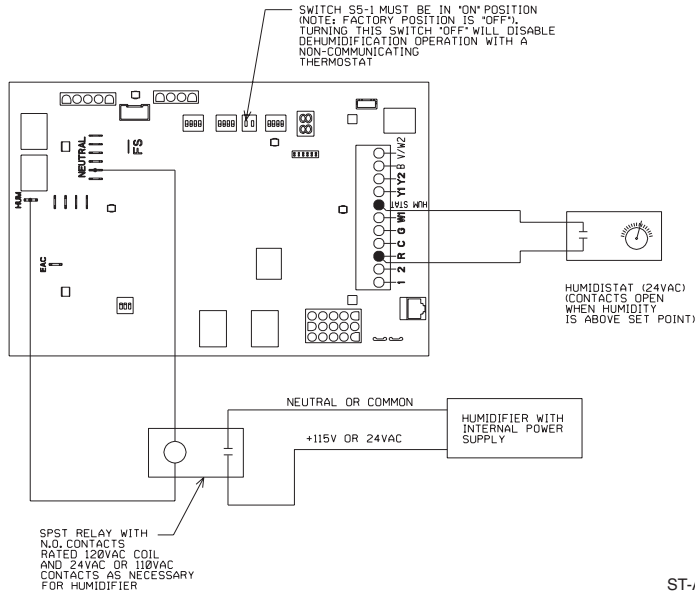
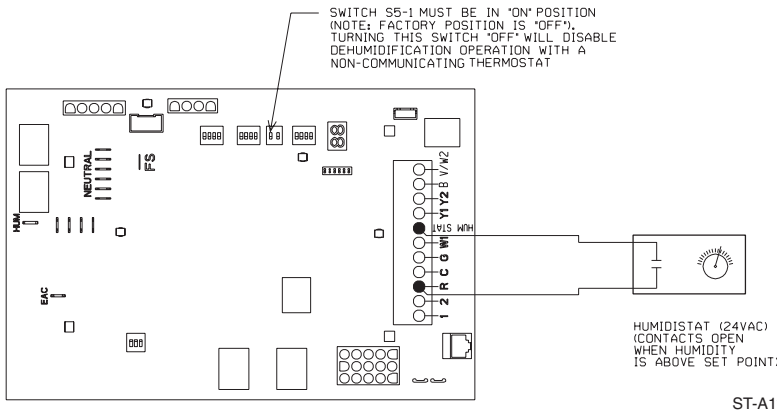

FIGURE 34
HUMIDISTAT USED TO CONTROL DEHUMIDIFICATION IN COOLING ONLY (NO HUMIDIFIER) (FOR USE WITH NON-COMMUNICATING THERMOSTATS)



permanently reduced by approximately 15% giving less than optimal performance and possibly causing problems. It is not recommended to leave this switch in the "ON" position without a humidistat installed.

Control of dehumidification in cooling and/or humidification in heating can be done with a variety of methods depending on whether there is a communicating thermostat or a humidistat available and depending on the type of operation desired.

With systems configured with communicating thermostats and condensers, dehumidification is controlled by the condenser and is not affected by the position of dipswitch S5-1 or the voltage (or lack of voltage) at the thermostat terminal labeled "HUM STAT".

To determine which wiring diagram and method to use, select from the following configurations:

A. HUMIDIFICATION CONTROL ONLY WITH NO DEHUMIDIFICATION (REQUIRES OPTIONAL HUMIDIFIER).

A1. WITH COMMUNICATING THERMOSTAT

Humidifier control is included with the (-)HC-TST412MDMS (modulating, non-communicating) and (-)HC-TST550CMMS (full-color communicating) model thermostats. However, it is not included with the (-)HC-TST501CMMS model communicating thermostat. The latter thermostat should not be used if humidification control is required. To wire the furnace for humidification control using either the (-)HC-TST412MDMS or the (-)HC-TST550CMMS, refer to the wiring diagram in Figure 31. Be sure not to install

the jumper between "R" and "HUM STAT" on the furnace control. Installing this jumper will operate the humidifier any time there is a heat call. Without the jumper, the humidification call from the thermostat must be active and a heat call must be present with the blower running.

A2. WITH NON-COMMUNICATING THERMOSTAT

A2-1 CONTINUOUS HUMIDIFIER OPERATION DURING HEATING.

For continuous humidifier operation during heating, refer to Figure 31 and make sure to install the jumper between the thermostat terminals labeled "R" and "HUM STAT". A separate humidistat is not required for this configuration and the humidifier will turn on whenever there is a call for heat and the blower is running.

A2-2 CONTROLLED HUMIDIFIER OPERATION USING A HUMIDISTAT

(REQUIRES OPTIONAL HUMIDISTAT). Controlled humidification can be accomplished using a humidistat as shown in Figures 32 or 33. These figures show installation of a humidifier with external and internal power supplies respectively. Dehumidification operation will be disabled if the dipswitch S5-1 is in the "OFF" position. If this switch is in the "ON" position, dehumidification control will be active.

B. DEHUMIDIFICATION CONTROL WITH NO HUMIDIFICATION

B1. For communicating thermostats listed with this furnace, dehumidification is controlled automatically when selected at the thermostat and additional wiring is not necessary. The actual airflow demand (reduced for dehumidification) is requested of the furnace by the condenser.

B2. WITH NON-COMMUNICATING THERMOSTAT (REQUIRES OPTIONAL HUMIDISTAT). Control of dehumidification only (no humidification) can be accomplished by installing an optional humidistat as shown in Figure 34. The dipswitch S5-1 must be set to the "ON" position. If this switch is not turned "ON", dehumidification operation will not take place. Further, if this switch is "ON" and no humidistat is installed, airflow in cooling will be permanently reduced by approximately 15%.

C. HUMIDIFICATION AND DEHUMIDIFICATION CONTROL (REQUIRES OPTIONAL HUMIDIFIER).

C1. WITH COMMUNICATING THERMOSTAT
Humidifier control is included with the (-)HC-TST412MDMS (modulating, non-communicating) and (-)HC-TST550CMMS (full-color communicating) model thermostats. However, it is not included with the (-)HC-TST501CMMS model communicating thermostat. Do not purchase the latter thermostat if humidification control is required. To wire the furnace for humidification and dehumidification control using the former thermostats, refer to the wiring diagram in Figure 31. Be sure not to install the jumper between "R" and "HUM STAT" on the furnace control.

Installing this jumper will operate the humidifier any time there is a heat call and dehu-

midification will never take place when in cooling. Without the jumper, a humidification call from the thermostat must be active and a heat call must be present with the blower running for the "HUM OUT" relay contacts to close.

C2. WITH NON-COMMUNICATING THERMOSTAT (REQUIRES OPTIONAL HUMIDISTAT.)
For non-communicating thermostats, an optional humidistat must be installed. Controlled humidification and dehumidification can be accomplished using a humidistat as shown in Figures 32 or 33. These figures show installation of a humidifier with external and internal power supplies respectively. Dehumidification operation will be disabled if the dipswitch S5-1 is in the "OFF" position. If this switch is in the "ON" position, dehumidification control will be active.

OTHER ACCESSORIES AVAILABLE

These kits are available through the finished goods department.

CONCENTRIC VENT TERMINATION KIT = RXGY-E03A

HORIZONTAL, TWO-PIPE TERMINATION KIT = RXGY-D02/D02A, RXGY-D03/D03A, OR RXGY-D04/D04A

VENT TERMINATION KIT: RXGY-G02

CONDENSATE PUMP KIT: RXGY-B01

NEUTRALIZER KIT: RXGY-A01

EXTERNAL BOTTOM FILTER RACK: RXGF-CB

EXTERNAL SIDE FILTER RACK: RXGF-CA



These parts are available through ProStock parts department.

ALTERNATE (LEFT-SIDE) DRAIN KIT (DOWNFLOW MODELS ONLY): RXGY-H01

TYPICAL WIRING ACCESSORIES FOR COMMUNICATING RESIDENTIAL SYSTEMS

The Rheem Serial Communicating (CC2) system allows accessories to be connected to shut down the system in the event of a fault. Typical devices that can be connected are the drain overflow switch, smoke detector and freeze protection switch. There are two methods of connecting the switch to the system depending on the device configuration normally closed or normally open. The blower can run during a fault or the blower can shut off during a fault depending on how the system is connected. Please refer to local and/or state codes for installing these devices. The following operation applies only when BOTH the condenser and thermostat are serial communicating devices. If the condenser is non-communicating (traditional, legacy 24VAC controlled) this diagram is not valid.

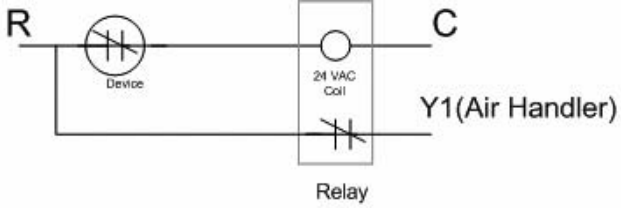
THERMOSTAT AND ACCESSORIES FOR THERMOSTAT
Programmable Modulating Thermostat: (-)HC-TST412MDMS
Remote Sensor: (For HC-TST412MDMS T-Stat Only) F1451378
Programmable Communicating Modulating: (-)HC-TST501CMMS
Full-Color, Programmable Communicating Modulating: (-)HC-TST550CMMS
Thermostat Wall Plate For Thermostats Above Only: F61-2600

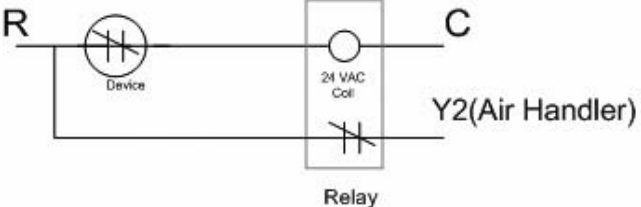
METHOD	BLOWER ACTIVATION	CONTACTS	WIRING CONFIGURATION
A	BLOWER RUNS (Y1)	NORMALLY OPEN	<p>When 24 VAC is applied to Y1 at the furnace control in a communicating system a SYSTEM BUSY message appears on the thermostat. When the SYSTEM BUSY message appears the outdoor unit will shut down and the indoor unit will continue to run at first stage cooling airflow.</p> 
		NORMALLY CLOSED	<p>If the device does not have normally open contacts an additional relay must be used for proper system operation.</p> 
B	BLOWER DOES NOT RUN (Y2)	NORMALLY OPEN	<p>When the device is connected to Y2 and a fault occurs the blower will shut down. The Y2 input can still be used with normally open or normally closed contacts.</p> 
		NORMALLY CLOSED	<p>If the device does not have normally open contacts an additional relay must be used for proper system operation.</p> 

HIGH ALTITUDE INSTALLATIONS IN THE U.S.

RGFG- HIGH ALTITUDE CONVERSION

▲ WARNING

FOR ALL MODELS, A PRESSURE SWITCH CHANGE IS NOT NECESSARY AT ANY ELEVATION UP TO 8,000 FT. HOWEVER, AT ELEVATIONS ABOVE 5,000 FT., AN ORIFICE CHANGE MAY BE REQUIRED. FURNACES ARE NOT TESTED ABOVE 8,000 FT. AND CANNOT BE INSTALLED ABOVE 8,000 FT.

Orifice Selection for High Altitude Applications For U.S. Installations
Natural Gas

▲ CAUTION

INSTALLATION OF THIS FURNACE AT ALTITUDES ABOVE 2000 FT (610 m) SHALL BE IN ACCORDANCE WITH LOCAL CODES OR, IN THE ABSENCE OF LOCAL CODES, THE NATIONAL FUEL GAS CODE, ANSI Z223.1/NFPA 54 OR NATIONAL STANDARD OF CANADA, NATURAL GAS AND PROPANE INSTALLATION CODE, CAN B149.1.

Elevations above 2000 ft. require the furnace to be de-rated 4% per thousand feet. **NOTE:** Factory installed orifices are calculated and sized based on a sea level Natural Gas heating value of 1075 BTU per cubic ft. Regional reduced heating values may nullify the need to change orifices except at extreme altitudes. Table 11 shows some quick conversions based on elevation and gas heating value. This table is combined and simplified from Tables F1 and F4 of the National Fuel Gas Code.

EXAMPLES

The following are examples of orifice sizing using the National Fuel Gas Code Appendix F. For a simplified estimation of orifice size based on heating value and elevation use Tables 11 and 12. However, calculations are the best method.

Example: 900 BTU/ft³ Regional Natural Gas Heating Value

$$I / H = Q$$

$$15000 / 900 = 16.68 \text{ ft}^3/\text{hr}$$

I = Sea Level input (per burner): 15000

H = Sea Level Heating Value: 900

Q = 16.68 ft³ Natural Gas per hour.

From Table F.1 of *National Fuel Gas Code Handbook, 2002* (3.5" w.c. column)

Orifice required at Sea Level: # 48

From Table F.4 of *National fuel Gas Code Handbook, 2002*

Orifice required at 5000 ft. elevation (4% de-rate per thousand ft): # 50

Orifice required at 8000 ft. elevation (4% de-rate per thousand ft): # 51

Example: 1050 BTU/ft³ Regional Natural Gas Heating Value

$$I / H = Q$$

$$15000 / 1050 = 14.63 \text{ ft}^3/\text{hr}$$

I = Sea Level input (per burner): 15000

H = Sea Level Heating Value: 1050

Q= 14.28 ft³ Natural Gas.

From Table F.1 of *National Fuel Gas code Handbook, 2002* (3.5" w.c. column)

Orifice required at Sea Level: # 50

From Table F.4 of *National Fuel Gas code Handbook, 2002*

Orifice required at 5000 ft. elevation (4% de-rate per thousand ft): # 51

Orifice required at 8000 ft. elevation (4% de-rate per thousand ft): # 52

TABLE 11
Natural Gas Orifice Drill Size (4% per 1000 ft. De-Rate)
IMPORTANT: For 90+ Furnaces only. Do not use this chart for any 80+ Furnace.
Burner Input (per burner) 15,000 BTU @ Sea Level

Annual Avg. Heat Value (btu per ft ³)	Sea level to 1999 ft	2000 to 2999 ft	3000 to 3999 ft	4000 to 4999 ft	5000 to 5999 ft	6000 to 6999 ft	7000 to 7999 ft	8000 to 8999 ft
850	47	48	48	49	49	49	50	50
900	48	49	49	49	50	50	50	51
1000	49	50	50	50	51	51	51	52
1075	50	51	51	51	51	52	52	52
1170	51	51	52	52	52	53	53	53

TABLE 12**90 Plus ONLY models with 15,000 Btu's per Burner. DO NOT USE THIS CHART FOR ANY 80 PLUS MODEL.**

NATURAL GAS QUICK REFERENCE CHART FOR ORIFICE SELECTION, AT 3.5" W.C. AND APPROXIMATE FINAL FIRING RATES

Sea Level Orifice Size	Sea Level Cubic Foot at 3.5" W.C.	90 Plus Heat Value at 15,000 Btu's per Burner	ELEVATION CHART (National Fuel Gas Code recommended orifice based on 4% derate for each 1000 foot of elevation, based on the intersection of the orifice required at Sea Level and the elevation required below)													
			0-999	1000-1999	2000-2999	3000-3999	4000-4999	5000-5999	6000-6999	7000-7999	8000-8999	9000-9999				
46	18.57	808	46	46	47	47	47	48	48	48	48	49	49	49	49	50
47	17.52	856	47	47	48	48	49	49	49	49	49	50	50	50	50	51
48	16.36	917	48	48	49	49	49	50	50	50	50	51	51	51	51	51
49	15.2	987	49	49	50	50	50	51	51	51	51	52	52	52	52	52
50	13.92	1078	50	50	51	51	51	52	52	52	52	53	53	53	53	53
51	12.77	1175	51	51	51	52	52	52	52	52	52	53	53	53	53	53
Final Firing Rate per Burner			15,000	14,400	13,800	13,200	12,600	12,000	11,400	10,800	10,200	9,600				

All calculations are performed by using the first three columns of information only. Before beginning any calculations, determine the individual burner Btu size and heating value at Sea Level for the installation site. Each value shown in the Heat Value column is per burner at 3.5" W.C.

NOTE:

Heat Value at Sea Level, for the location of the installation, is available from the Natural Gas Supplier to that site. Orifices for all altitudes are based on Sea Level values.

Divide the individual burner capacity (15,000 for 90 plus) by the Heat Value for the site to determine the Cubic Foot value at Sea Level, or divide burner capacity by the Cubic Foot value for the Heat Value. Once you have either the Cubic Foot Value or the Heat Value you can estimate the Sea Level orifice for the site. To select the corresponding high altitude orifice, locate the site elevation on the chart above and the orifice required at Sea Level from your calculation in the first column. The correct high altitude orifice that must be installed in each individual burner is the intersection of these two points on the chart above.

LP GAS AT HIGH ALTITUDE ELEVATIONS IN THE U.S.

LP Gas is a manufactured gas that has consistent heating value across most regions.

The National Fuel Gas Code (N.F.G.C.) guidelines are used with the following exception:

The recommended LP Gas high altitude orifice selections differ slightly in that the NFGC LP orifice chart, as they are not accurate for the RGFG gas furnaces. The National Fuel Gas Code LP orifices are based on an 11" of water column pressure at the orifice, which differs from products that use 10" of water column at the orifice. This difference requires a deviation from the NFGC orifice size recommendations. The Sea Level input should still be reduced by 4% per thousand ft. and the orifice size must be selected based on the reduced input selection shown in Table 13.

Orifice Ordering Information

Orifice sizes are selected by adding the 2-digit drill size required in the orifice part number. Drill sizes available are 39 through 64; metric sizes available 1.10mm (-90) and 1.15mm (-91):

Orifice Part Number 62-22175-(drill size)

Example 1:

#60 drill size orifice required

Part #62-22175-60

Example 2:

1.15mm drill size orifice required

Part #62-22175-91

TABLE 13

LP Gas Orifice Drill Size and per burner de-rate by elevation based on 15,000 btu 90+ burners.

IMPORTANT: For 90+ Furnaces only. Do not use this chart for any 80+ Furnace.

Altitude	Input (per burner) 15000	Orifice Size
0 to 2000 ft.	15000	1.15 mm (factory)
2001' to 3000'	13200	1.15 mm
3001' to 4000'	12600	1.10 mm
4001' to 5000'	12000	#58
5001' to 6000'	11400	#59
6001' to 7000'	10800	#60
7001' to 8000'	10200	#62
8001' to 9000'	9600	#63
9001' to 10000'	9000	#64

ALTERNATE METHOD FOR CANADIAN HIGH-ALTITUDE DERATE

In Canada, unless an orifice change is specifically mandated by local codes, an alternate method of altitude deration through a reduction in manifold pressure is acceptable as described in Table 14.

The information in Table 14 is based on a heating value of 1000 BTU per cubic feet of natural gas, and 2500 BTU per cubic feet of LP gas.

IMPORTANT: Actual input rates must be measured on-site with manifold pressure adjustment to ensure that an actual 10% reduction in input rate is achieved.

Once this field adjustment has been made, the label shown in Figure 35 must be affixed in a conspicuous location on the front of the furnace cabinet:

NOTE: This label is supplied in the information packet shipped with each furnace.

TABLE 14

ALTERNATE METHOD FOR CANADIAN HIGH-ALTITUDE DERATE

IMPORTANT: 90+ MODELS ONLY. DO NOT USE THIS CHART FOR ANY 80 PLUS MODELS.

NATURAL GAS					LP GAS				
ALTITUDE	INPUT	OUTPUT	ORIFICE SIZE	MANIFOLD PRESSURE	ALTITUDE	INPUT	OUTPUT	ORIFICE SIZE	MANIFOLD PRESSURE
0' - 2000'	45,000	40,500	#50	3.5" W.C.	0' - 2000'	45,000	40,500	1.15mm	10" W.C.
	60,000	54,000				60,000	54,000		
	75,000	67,500				75,000	67,500		
	90,000	81,000				90,000	81,000		
	105,000	94,500				105,000	94,500		
120,000	108,000	120,000	108,000						
2001' - 4500'	40,500	36,450	#51	3.0" W.C.	2001' - 4500'	40,500	36,450	1.10mm	7.6" W.C.
	54,000	48,600				54,000	48,600		
	67,500	60,750				67,500	60,750		
	81,000	72,900				81,000	72,900		
	94,500	85,050				94,500	85,050		
108,000	97,200	108,000	97,200						

**FIGURE 35
MANIFOLD PRESSURE-CHANGE LABEL**

THE MANIFOLD PRESSURE OF THIS APPLIANCE HAS BEEN FIELD ADJUSTED TO OBTAIN THE CORRECT INPUT RATING FOR INSTALLATION AT ALTITUDES BETWEEN 2,000 FEET AND 4,500 FEET ELEVATION.

LA PRESSION DU DISTRIBUTEUR D'ALIMENTATION DE CET APPAREIL A ÉTÉ AJUSTÉ SUR LES LIEUX AFIN D'OBTENIR LA BONNE PUISSANCE D'ENTRÉE POUR UNE INSTALLATION ENTRE 2000 ET 4500 PIEDS D'ALTITUDE. 92-24399-01-01

ZONING SYSTEMS

The manufacturer does not currently provide or support zoning with modulating furnace. However, zoning systems can be installed with the system as long as the zoning equipment manufacturers specifications and installation instructions are met and followed.

The preferred zoning method is to use a "bypass" system which is properly installed for maximum efficiency. In these systems, excess air is routed back through the system to be used again – this is opposed to a "dump" system in which excess air is routed to a zone where it is expected that the extra heat or cooling would be least noticed.

If installed as a "bypass" system, the installation must have an optional freeze stat installed to prevent the coil from icing with excess bypass cooling. Also, if the zoning equipment manufacturer provides a limit switch (usually provided by the zoning manufacturer), this limit must be installed in the system to prevent the furnace from overheating.

FURNACE INSTALLATION WITH NON-COMMUNICATING HIGH-EFFICIENCY PREMIUM COOLING OR HEAT PUMP SYSTEMS

Furnace installation with Rheem/Ruud -ASL or -ARL outdoor condensing units can provide high efficiency (up to 16 SEER) cooling operation when combined with proper evaporator coil. For listed cooling equipment combinations, see the -ARA or -ARL specification sheets and Tables 15 and 16 of this document. Using Tables 15 and 16 and literature provided with the cooling equipment, the installer needs to make sure that the proper evaporator coil, condensing coil and airflow is configured to achieve rated efficiency.

In accordance with Rheem/Ruud cooling equipment installation instructions, do not install an evaporator coil or coil casing to the furnace which is smaller in width than the furnace cabinet.

UP TO 16 SEER COOLING OPERATION

Check the revision number of the integrated furnace control (IFC) to determine how best to configure your furnace for high SEER operation.

To achieve high SEER operation, turn dip switch S5-2 to the "off" position (factory setting). This will enable the furnace operation for 16 SEER. Actual SEER values will vary and depend on the equipment combination. Consult the specifications sheets and installation instructions of the cooling equipment purchased for a listing of the SEER ratings for a specific combination.

TABLE 15

AIRFLOW AND CONDENSER SELECTION – PREMIUM (NON-COMMUNICATING) COOLING SYSTEMS (1 STAGE COOL ONLY)
(NOTE: SWITCH S5-2 OF THE IFC MUST BE IN THE "OFF" POSITION FOR OPTIMUM PERFORMANCE)

TONS	FURNACE		APPROX. AIRFLOW (CFM)	CONDENSING UNIT	MOD. FURNACE IFC DIP-SWITCH SETTINGS	
	MODEL	WIDTH			S3,#1	S3,#2
2	(-)GFG-06 & -07	17.5"	800	-ARA-24	OFF	ON
2-1/2	(-)GFG-06 & -07*	17.5"	1000	-ARA-30	ON	OFF
3	(-)GFG-09 & -10*	21"	1200	-ARA-36	ON	ON
3-1/2	(-)GFG-09 & -10*	21"	1400	-ARA-42	ON	ON
3	(-)GFG-12	24.5"	1200	-ARA-36	ON	ON
3-1/2	(-)GFG-12	24.5"	1400	-ARA-42	ON	ON

Evaporator coil must be the same width as the furnace OR one size larger in width than the gas furnace.
(See condenser spec. sheet, I&O and other literature for evaporator selection)

TABLE 16

AIRFLOW AND CONDENSER SELECTION – PREMIUM (NON-COMMUNICATING) COOLING SYSTEMS (2 STAGE COOL)
(NOTE: SWITCH S5-2 OF THE IFC MUST BE IN THE "OFF" POSITION FOR OPTIMUM PERFORMANCE)

TONS	FURNACE		APPROX. AIRFLOW (CFM)	CONDENSING UNIT	MOD. FURNACE IFC DIP-SWITCH SETTINGS	
	MODEL	WIDTH			S3,#1	S3,#2
2	(-)GFG-06 & -07	17.5"	800	-ARL/ASL-24	OFF	ON
3	(-)GFG-06 & -07	17.5"	1200	-ARL/ASL-36	OFF	OFF
3	(-)GFG-09 & -10	21"	1200	-ARL/ASL-36	ON	ON
3	(-)GFG-12	24.5"	1200	-ARL/ASL-36	ON	ON
4	(-)GFG-09 & -10	21"	1600	-ARL/ASL-48	ON	OFF
4	(-)GFG-12	24.5"	1600	-ARL/ASL-48	ON	OFF
5	(-)GFG-12	24.5"	1800	-ARL/ASL-60	OFF	OFF

Evaporator coil must be the same width as the furnace OR one size larger in width than the gas furnace.
(See condenser spec. sheet, I&O and other literature for evaporator selection)

INTEGRATED FURNACE CONTROL (I.F.C.)

FIGURE 36
MODULATING CLIMATE-TALK COMMUNICATING FURNACE CONTROL (RHEEM # 62-102783-01)

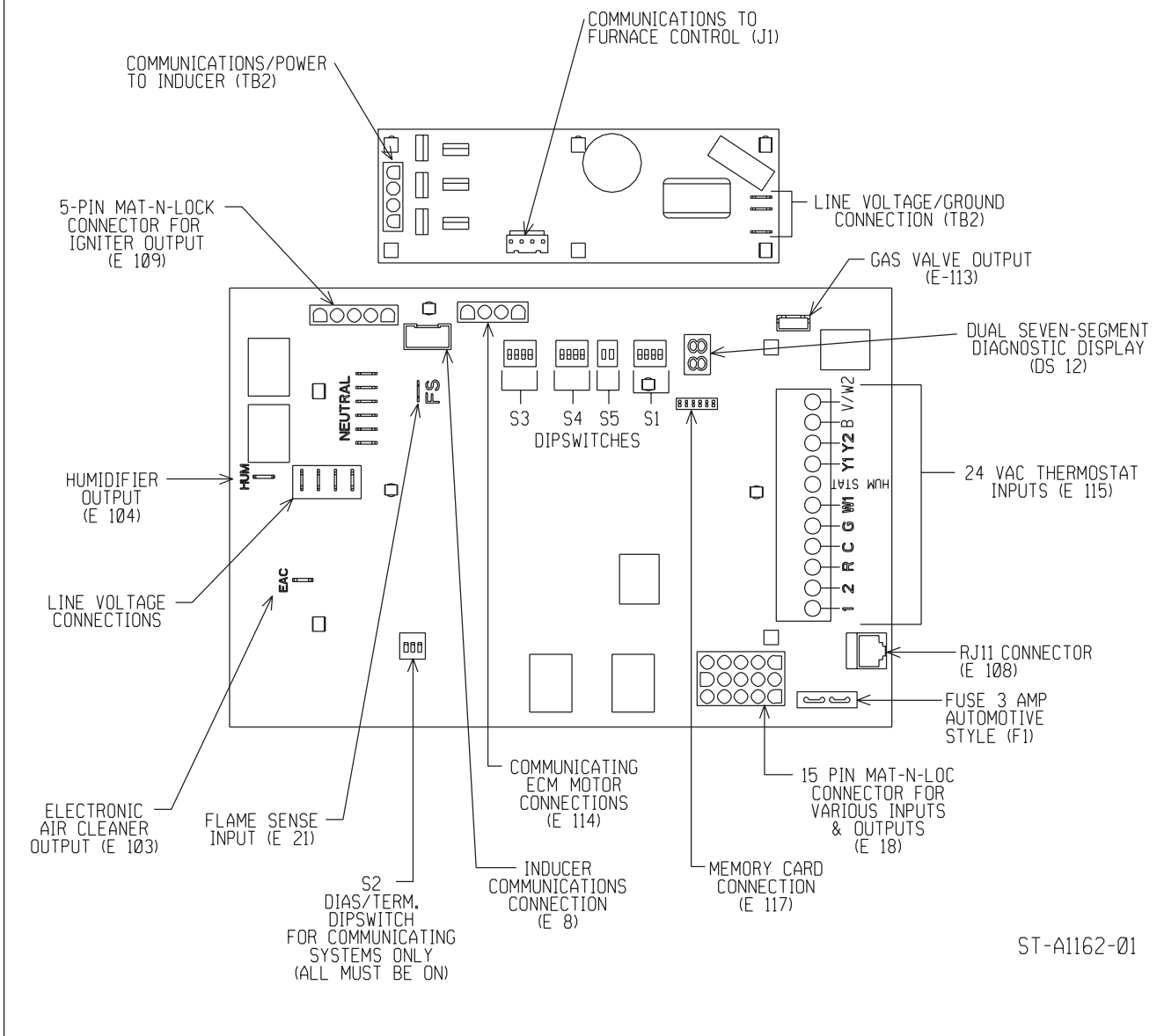

SEVEN SEGMENT DISPLAY:

The furnace control displays status and diagnostic information at the Seven Segment Display. When viewing the display the observer should be aware that the top of the digit is to the left and the bottom of the digit is to the right (upflow models). Figure 37 details proper reading of the diagnostic display. Operation is described in detail below:

STANDBY MODE:

"0" displayed steady.

HEATING MODE:

"H" is displayed followed by a one digit number. The number represents the current firing rate. For example "H7"

would represent heating mode operating at 70% of firing rate ("H0" represents 100% heat). This is then toggled with two numbers which indicate the CFM of the main circulating blower divided by 100. For example, if "18" is displayed, the furnace is attempting to deliver 1800 CFM of air.

For example, if "H7" is displayed followed by "14" (toggling), this would indicate that the furnace is operating at 70% heat with the airflow operating at 1400 CFM.

COOLING MODE:

"C" is displayed. This is then toggled with two numbers which indicate the CFM of the main circulating blower divided by 100. For example, if "18" is displayed, the furnace is attempting to deliver 1800 CFM of air.

For example, if "C" is displayed followed by "12" (toggling), this would indicate that the system is in air conditioning mode with the airflow operating at 1200 CFM.

HEAT PUMP HEAT MODE (COMMUNICATING DUAL-FUEL SYSTEMS):

"HP" is displayed. This is then toggled with two numbers which indicate the CFM of the main circulating blower divided by 100. For example, if "18" is displayed, the furnace is attempting to deliver 1800 CFM of air.

For example, if "HP" is displayed followed by "12" (toggling), this would indicate that the system is in heat-pump heat mode with the airflow operating at 1200 CFM.

FIGURE 37

WHEN VIEWING THE SEVEN-SEGMENT DISPLAY THE BOTTOM OF THE DIGITS IS ON THE RIGHT SIDE OF THE CONTROL BOARD, CLOSER TO THE THERMOSTAT TERMINAL BLOCK. FOUR (4) EXAMPLES ARE SHOWN.

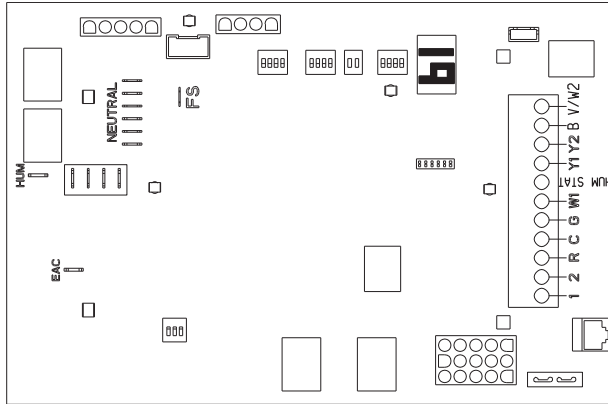

THIS EXAMPLE IS 61 NOT 19

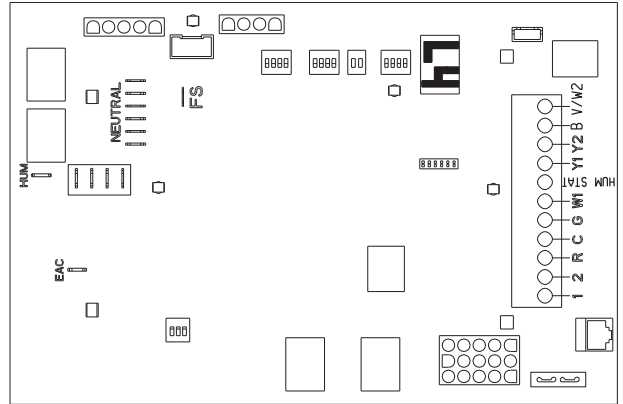

THIS EXAMPLE IS h7 NOT L4

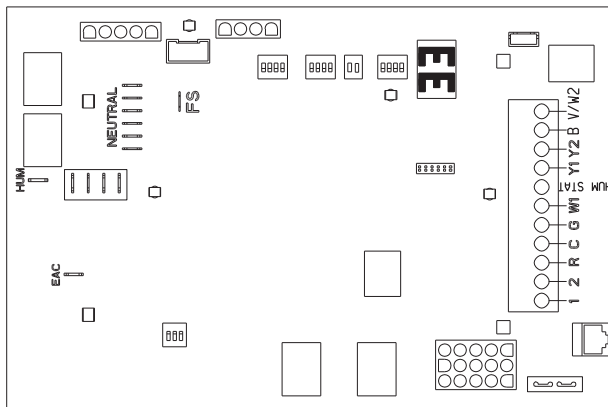

THIS EXAMPLE IS 33 NOT EE

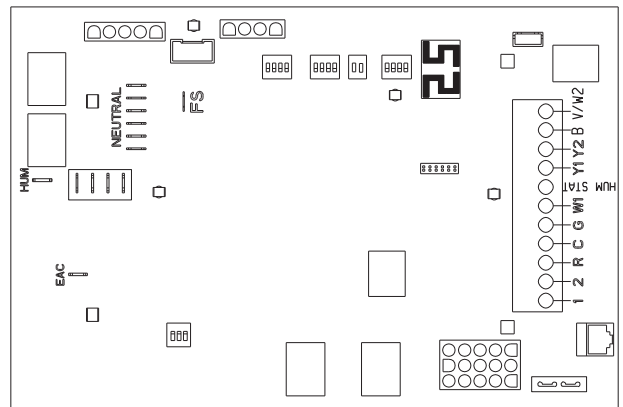

THIS EXAMPLE IS 25 NOT 52

ST-A1183-01

FIGURE 38

WIRING DIAGRAM – SPECIAL CONFIGURATION: COMMUNICATING THERMOSTAT AND FURNACE WITH NON-COMMUNICATING CONDENSER

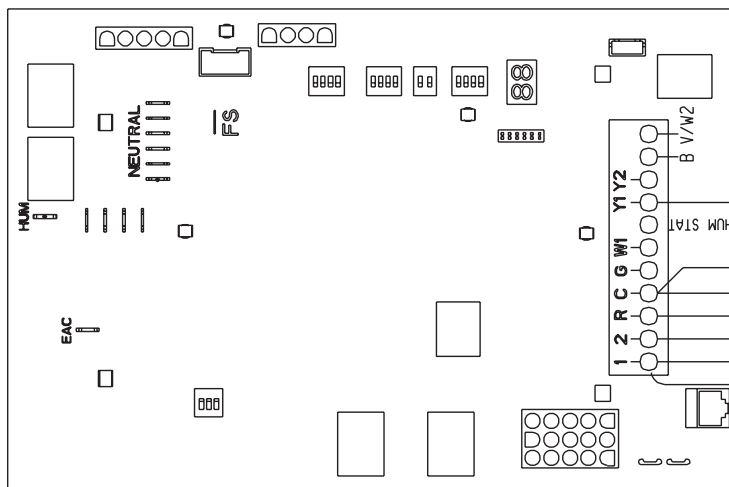

NOTE:
DEHUMIDIFICATION FUNCTION FROM A COMMUNICATING THERMOSTAT WILL NOT BE POSSIBLE WITH THIS CONFIGURATION.

100 FEET MAX. @ 18 GA.

NOTE:
THIS CONFIGURATION IS VALID FOR A.C. CONDENSERS ONLY. HEAT PUMP CONDENSERS CAN NOT BE INSTALLED IN THIS CONFIGURATION BECAUSE THERE IS NO CONTROL OUTPUT FOR A REVERSING VALVE AVAILABLE.

ST-A1173-01

CONTINUOUS FAN MODE:

“F” is displayed. This is then toggled with two numbers which indicate the CFM of the main circulating blower divided by 100. For example, if “18” is displayed, the furnace is attempting to deliver 1800 CFM of air.

For example, if “F” is displayed followed by “12” (toggling), this would indicate that the system is in continuous fan mode with the airflow operating at 1200 CFM.

FAULT PRESENT MODE:

When a fault is present, it is displayed **continuously and is not toggled** with another number. For example, if the furnace loses flame sense unexpectedly, “13” is displayed continuously until the fault clears.

24 VAC THERMOSTAT (TSTAT) INPUTS (J4 & J6)

24 VAC THERMOSTAT (TSTAT) INPUTS (E-115)

These connections are used with any traditional 24VAC one-stage or two-stage thermostat or the modulating, non-communicating, thermostat specified for this modulating furnace. Fully communicating thermostats must be connected to the COMM NETWORK CONNECTION (see section titled **COMMUNICATING SYSTEMS** of this document for details). Optimum heating performance will be realized only with the fully modulating thermostat (either communicating or non-communicating).

W1, Y1, Y2, G, C and R are the traditional thermostat inputs used in nearly all HVAC equipment. Installation of the thermostat to these connections is straightforward and simple.

HUM STAT – This terminal is used to connect the output of a humidistat to the furnace control to control humidification and/or dehumidification. Optional equipment is required for these features. Please see the section titled **HUMIDIFICATION AND DEHUMIDIFICATION** of this document for more details.

V/W2 – This terminal is used to connect the modulating signal (V) from a non-communicating, fully modulating thermostat specified for use with this furnace. It is used to transmit the firing rate (determined by the thermostat) to the furnace control. In addition, a traditional 24VAC signal from a two-stage thermostat terminal labeled “W2” can be connected to this terminal to activate the timed staging feature of this furnace.

Note: Do not apply 24vac to the V/W2 terminal (as with a jumper to R for diagnostic purposes) when a non-communicating, modulating thermostat is installed.

B – This terminal is used to pass a reversing valve signal to a condenser. It is only a holding place for connecting a wire from the thermostat and a wire from the condenser. It does not change the airflow of the cool/heat commands.

SPECIAL CONFIGURATION – COMMUNICATING THERMOSTAT AND FURNACE WITH A NON-COMMUNICATING CONDENSER

Y1 – This terminal may be used to connect directly to a non-communicating condenser when a communicating thermostat is installed to the furnace but a non-communicating condenser is installed in the system. While the optimum configuration is with a communicating condenser connected to the network, there may be installations where this is not desired. In these cases, the thermostat will be communicating with the furnace control and the furnace control will energize the condenser as necessary (the additional relays have been added to the furnace control to allow this operation).

The thermostat connection labeled “Y1” on the I.F.C. is normally an **input** to the furnace control to turn on the blower when they are energized. However, in this configuration, this (normally) input becomes an **output** to energize the condenser when a cooling call has been sent from the communicating thermostat.

When this configuration is desired, use the wiring diagram in Figure 38 to connect the thermostat and condenser to the furnace control.

NOTE: A heat pump condenser cannot be installed with this configuration. There is no control for the reversing valve.

FUSE (F1)

A three-amp automotive-style (ATC blade type) fuse is supplied on-board the furnace control. This fuse should provide protection from short-circuits on the control board and associated 24 VAC wiring.

115 VAC TERMINALS

These terminals supply 115 VAC to the furnace control from the input at the junction box of the furnace. Additionally, spare terminals are provided for use with electronic air cleaners and other accessories as needed (Check the voltage rating of your equipment.)

INDUCED DRAFT MOTOR (INDUCER) CONTROL OUTPUT (E8)

This four-pin connector is white in color and provides control command to both the high and low speed inducer outputs.

For troubleshooting purposes, follow the wiring diagram and troubleshooting flowchart supplied in this manual and on the inside of the furnace blower door. Additionally, the pin designations for the connector are specified below:

Pin 1 to Inducer 12V

Pin 2 to Inducer Rx

Pin 3 to inducer GND

Pin 4 to inducer Tx

NEUTRAL TERMINALS

These terminals connect 115VAC neutral to the furnace control from the input at the junction box of the furnace. Additionally, spare terminals are provided for use with electronic air cleaners, humidifiers and other accessories as needed (Check the voltage rating of your equipment.)

ELECTRONIC AIR CLEANER (E.A.C.) OUTPUT (E-103)

This output is used to energize an electronic air cleaner. The output will provide 1.0 amp at 115 VAC. This output is energized any time the blower motor is above 40% of maximum airflow capacity. Airflow below this value is not considered to be enough for a typical electronic air cleaner to perform properly.

For 1/2HP motors – Electronic air cleaner is energized any time the blower is above 480 CFM (1200 CFM x 0.4)

For 1 HP motors - Electronic air cleaner is energized any time the blower is above 800 CFM (2000 CFM x 0.4)

HUMIDIFIER OUTPUT (J8)

Details about the humidifier outputs and wiring diagrams can be found in the section titled **HUMIDIFICATION AND DEHUMIDIFICATION** of this document.

STEPPER GAS VALVE CONTROL (E113)

For furnaces equipped with a stepper modulating gas valve, a five-pin connector is used to control and sense the gas valve. The valve uses a PWM (Pulse Width Modulated) signal to control the firing rate. The duty cycle of this signal is five percent less than the expected firing rate. For example, if the firing rate is 90%, the PWM to (and from) the valve will be 85% duty cycle. The connector also provides the 24VAC signal to energize the main valve solenoid. Reference the wiring diagram for the furnace printed in this document or on the inside of the furnace blower door.

For troubleshooting purposes, follow the wiring diagram and troubleshooting flowchart supplied in this manual and on the inside of the furnace blower door. Additionally, the pin designations for the connector are specified below:

Pin 1 to stepper modulating gas valve connector Pin 1 (TH)

FIGURE 39
15-PIN CONNECTOR; J1 WITH PIN DESIGNATIONS

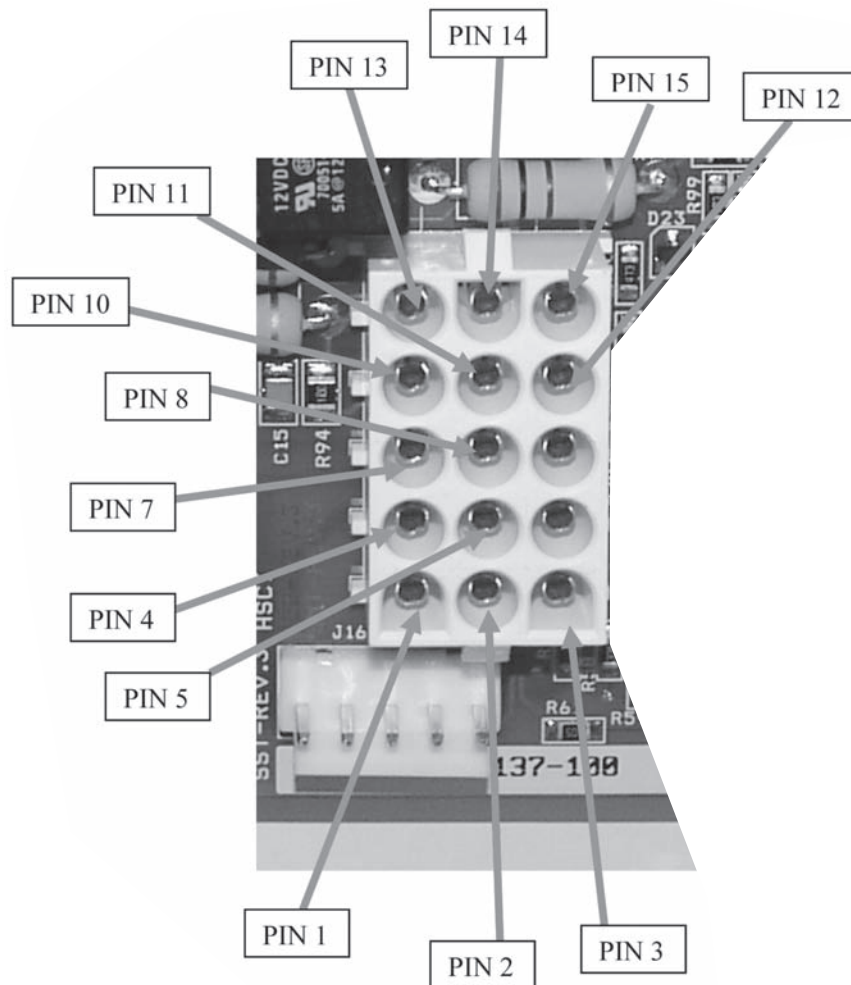

Pin 2 to stepper modulating gas valve connector Pin 2 (RX)

Pin 3 to stepper modulating gas valve connector Pin 3 (TX)

Pin 4 to stepper modulating gas valve connector Pin 4 (COMMON)

Pin 5 to stepper modulating gas valve connector Pin 5 (MVTH)

15-PIN MATE-N-LOK CONNECTOR (J1) (see Fig 39)

The 15-pin Mate-n-Lok style connector provides connections for a variety of inputs and outputs to the furnace control. The flame sense, pressure switches sense and limits sense (Main Limit, MRLC and HALC) are connected to the I.F.C. through this connector. Reference the wiring diagram for the furnace printed in this document or on the inside of the furnace blower door for pin assignments for troubleshooting.

For troubleshooting purposes, follow the wiring diagram and troubleshooting flowchart supplied in this manual and on the inside of the furnace blower door.

Additionally, the pin designations for the connector are specified below:

- Pin 1.** HLI HIGH LIMIT INPUT
- Pin 2.** PS1 LOW PRESSURE SWITCH OUTPUT
- Pin 3.** RLI ROLL OUT SWITCH INPUT
- Pin 4.** TH 24V HOT
- Pin 5.** GND GROUND
- Pin 6.** NOT USED
- Pin 7.** PSO PRESSURE SWITCH OUTPUT
- Pin 8.** MVC MAIN VALVE COMMON
- Pin 9.** ILI INDUCER LIMIT INPUT
- Pin 10.** HLO HIGH LIMIT OUTPUT
- Pin 11.** TR 24V RETURN
- Pin 12.** PS2 SECOND PRESSURE SWITCH OUTPUT
- Pin 13.** MVL MAIN VALVE LOW
- Pin 14.** MVH MAIN VALVE HIGH
- Pin 15.** AXI AUXILIARY SWITCH INPUT

COMMUNICATING ECM MOTOR COMMUNICATIONS (CONTROL) CONNECTION (E114)

This connector sends and receives messages to and from the blower motor through a single peer-to-peer

network. The blower motor does not communicate on the same communications buss as the furnace, condenser and thermostat. Further, a different communications protocol is used.

For troubleshooting purposes, follow the wiring diagram and troubleshooting flowchart supplied in this manual and on the inside of the furnace blower door. Additionally, the pin designations for the connector are specified below:

Pin 1 to communicating blower motor connector Pin 1 (+V)

Pin 2 to communicating blower motor connector Pin 2 (TX)

Pin 3 to communicating blower motor connector Pin 3 (RX)

Pin 4 to communicating blower motor connector Pin 4 (C)

R-J11 CONNECTOR (E109)

▲ WARNING

DO NOT CONNECT A TELEPHONE OR PHONE LINE TO THE CONNECTOR (JACK) AT POSITION E109. DOING SO COULD CAUSE IRREPRABLE DAMAGE TO EITHER THE FURNACE CONTROL (I.F.C.) OR THE TELEPHONE (OR TELEPHONE LINE) OR BOTH.

This connector is used to program the furnace control at the factory. It can also be used to connect a field service diagnostic tool. Unfortunately, this tool was not available at the time of this publication but should be available in the future. Otherwise, this connection is not to be used in the field. It should never be connected to a telephone line or a telephone. Doing so could damage the furnace control or the telephone (or telephone lines) or both.

COMMUNICATIONS NETWORK CONNECTIONS

These connections are used when installing a communicating thermostat specified for use with this furnace. Further, normally, thermostat connections will not be made at the legacy 24 V Thermostat Inputs when using a communicating thermostat. (Except under one special circumstance where a communicating thermostat and non-communicating condenser are used. (See Figure 38 and the section of this document titled **SPECIAL CONFIGURATION – COMMUNICATING THERMOSTAT AND FURNACE WITH A NON-COMMUNICATING CONDENSER.**)

The terminal labeled “1” on the furnace control connects directly to the terminal labeled “1” on the thermostat and “1” on the condenser. The remaining connections follow the same pattern.

Follow the wiring diagram in Figure 37 for connections of the communications network.

COMMUNICATIONS L.E.D.’s (Light Emitting Diodes)

Note: The “RX” and “STAT” L.E.D.’s will not operate unless a communicating thermostat is installed. These L.E.D.’s will not energize if a traditional 24V thermostat only is used to control the furnace.

“RX” (Green) L.E.D. – This L.E.D. indicates that communications is being sensed to or from (i.e.: *something* on the network is trying to communicate) other components (e.g. a condenser) on the network. This L.E.D. will blink randomly any time a message is received by the furnace control. If no blinking is seen within five minutes, it can be

assumed that there is not valid communications established. Check wiring to make sure that all points are connected properly.

Further, if this L.E.D. is on continuously, it is an indication that mis-wiring has occurred. Most probably, connections “1” and “2” are reversed. Double-check the wiring and make sure that the wire connected to pin “1” on the condenser is the same wire connected to pin “1” on the thermostat and the furnace control. The same follows for the wires to pins “2”, “R” and “C”.

“STAT” (STATUS) (Red) L.E.D. – This L.E.D. blinks twice slowly (¼ second ON, ¾ second OFF) upon power-up.

LEARN BUTTON

Pressing the learn button for two seconds will cause the green “RX” L.E.D. to blink rapidly (for a short period) to indicate an attempt at communications. If the L.E.D. does not blink, communications can not be established. The problem may be that the wires at the J9 connector “1” and “2” on the I.F.C. may be reversed. Check to make sure that wiring is from “1” on the IFC leads to “1” on the thermostat and condenser (if present) and the same follows for connections “2”, “R” and “C”.

MEMORY CARD CONNECTOR (E117)

This connector is used to insert a memory card.

MEMORY CARD

A memory card is defined as an electronic card that carries a copy of the furnace shared data.

RULES FOR WRITING, DISTRIBUTION AND ARBITRATION OF MULTIPLE COPIES OF FURNACE SHARED DATA FOR COMMUNICATING-CAPABLE FURNACES

Furnace shared data is defined as data specific to a given furnace that is critical for proper furnace operation. More specifically, it is data which defines the operation of the furnace and is unique to a given furnace platform and model. The most critical of these data are the coefficients that control the blower operation (i.e. define the blower speed-torque operation). Because of this, each furnace control is programmed with furnace shared data for that model furnace only. The furnace shared data from any given furnace can NOT be transferred to another furnace for any reason. Doing so can adversely affect operation of the furnace. Further, if no furnace shared data is present, the furnace will not operate in any mode and a fault will be displayed.

Valid Furnace Shared Data is defined as furnace shared data for the furnace series in question with the correct motor horsepower. However, it is impossible for the furnace control to determine if the furnace shared data is matched to the furnace input BTU’s if the motor horsepower is correct. This means, for example, furnace shared data for a 120KBTU upflow furnace could be installed and recognized as valid furnace shared data in a 90KBTU downflow furnace. VALID FURNACE SHARED DATA simply means that there is no motor horsepower conflict and that the furnace shared data is for the series of furnace in question. VALID FURNACE SHARED DATA is data that will be used by the furnace control with no fault reported. VALID FURNACE SHARED DATA may not necessarily mean that the furnace shared data is correct for the furnace in question. The input BTU’s could still be incorrect and this is why it is important to never exchange memory cards from one furnace to another.

Furnace shared data is programmed into the furnace control microprocessor and attached memory card at the factory. The attached memory card cannot be programmed in the field but furnace shared data inside the furnace IFC microprocessor may be written or rewritten in the field through the network depending on the circumstances.

▲ WARNING

DO NOT REPLACE THE FURNACE CONTROL OR MEMORY CARD OF THE FURNACE WITH A FURNACE CONTROL OR MEMORY CARD OF ANOTHER FURNACE OR ANOTHER COMPONENT (E.G.: A MEMORY CARD FROM A CONDENSER OR AIR HANDLER). THE WRONG FURNACE CONTROL OR MEMORY CARD MAY SPECIFY PARAMETERS WHICH WILL MAKE THE FURNACE RUN AT UNDESIRE CONDITIONS INCLUDING (BUT NOT NECESSARILY LIMITED TO) REDUCED AIRFLOW DURING HEATING CAUSING EXCESSIVE UNDESIRE OPERATION OF THE MAIN LIMIT CONTROL. FURTHER, THE MEMORY CARD IS SPECIFIC TO THE MODEL NUMBER AND BTU INPUT RATING FOR A SPECIFIC FURNACE AND THIS INFORMATION SHOULD NOT BE TRANSPORTED FROM ONE FURNACE (OR COMPONENT) TO ANOTHER.

The memory card is the default memory location to be used first when there is any conflict. If the memory card has been replaced with a card that has data for another furnace, the furnace will assume the identity of the “other” furnace. In all cases, the memory card has the final say about the data to use. It is only when the memory card is not present, is corrupt or specifies a motor larger or smaller than what is found in the furnace that the furnace control will use the data stored in the microprocessor (a mirror of the most recent memory card with blower size matching that found in the furnace). The hierarchy of data to be used in the event of a lost card or conflict is listed in order of importance below.

1. If **no memory card present**, –

- a. Furnace shared data from the “network” is used. Furnace network shared data is defined as a redundant copy (or copies) of the critical furnace shared data stored at various places and components on the communicating network.

The “network” can be defined as follows:

- I. The “network” can be the furnace control itself if it was programmed at the factory and the memory card has been removed for some reason.
- II. The “network” can be a furnace control which has had a valid card previously (either attached or inserted) and removed for some reason.
- III. The “network” can be a furnace control attached to a communicating condenser and/or thermostat which has copies of the furnace shared data that can be retrieved by the furnace control.

- IV. A furnace control sent as a replacement part will have no furnace shared data either in the microprocessor or on the memory card. The replacement control does not include a valid memory card. The furnace shared data can be added by:

- 1. Inserting a valid memory card (e.g. the original memory card sent with the original furnace control or a valid replacement memory card ordered from ProStock.

or

- 2. by attaching the furnace control to a communicating network (e.g. a condenser and thermostat) which was previously connected to (and operating with) a valid furnace control with valid furnace shared data.

Regardless, the memory card of a replacement control cannot be programmed or reprogrammed in the field with furnace shared data and will always remain blank. In fact, this card does not even contain the electronic components necessary to turn it into a valid memory card.

- V. Replacement memory cards with the appropriate furnace shared data for any given model can be ordered from Pro-Stock. In the event that the original memory card is lost, the original furnace control has been replaced and there is no furnace shared data on the network (or the furnace is not part of a communicating network (i.e.: is not connected to a communicating condenser and thermostat)), the replacement memory card must be ordered and installed into the connector at J15 to give the furnace valid furnace shared data. The furnace will not operate properly without the correct furnace shared data. When no furnace shared data is present (either at the memory card or on the network) a “d1” (NO SHARED DATA) fault code will be displayed at both the thermostat active fault screen and at the furnace control (I.F.C.) seven-segment displays. Also, the homeowner will be alerted via the communicating thermostat with either a CHECK SYSTEM or CHECK FURNACE error message displayed on the main screen.

If the original memory card is lost, it should be replaced even if there is valid furnace shared data on the network. The valid furnace shared data on the network should only be considered as a backup to the memory card.

- b. If valid furnace shared data is available from the network and no memory card is present, a “d4” (MEM CARD INVALID) fault is displayed at the communicating thermostat active fault screen and at the furnace seven-segment displays when in standby mode only (see fault code priority list). The homeowner is not alerted (level 1 fault).
 - c. If no furnace shared data is present on the network and a memory card is either not present or the shared data on the memory card is not valid, a “d1” (NO SHARED DATA) fault is displayed at both the communicating thermostat active fault screen and at the furnace seven-segment displays provided a higher priority fault code is not also present (in which case the higher priority fault is displayed) (see fault code priority list). The homeowner is alerted via the communicating thermostat (level 2 fault).
 - d. If furnace shared data from the memory card is not valid or is not present and shared data from network can be used, the appropriate fault (d4, d5, d6, d7 or d8 – see fault codes in this manual) is displayed at the communicating thermostat active fault screen and at the furnace seven-segment displays during standby mode only. The homeowner is not alerted (level 1 fault).
2. If **memory card present** (attached to IFC **or** inserted in J15 of the IFC), furnace shared data from the memory card (if valid) will be used to write (or rewrite) the network furnace shared data and furnace shared data from card will be used. If the data on that card is not valid,:

- a. If furnace shared data on the memory card
 - I. is corrupt or invalid (“d4” – MEM CARD INVALID”), and/or
 - II. is for another component or different furnace series (“d5” – CARD-HARD CNFLCT),

and/or

III. does not match the horsepower of the attached motor ("d6" - BLWR HP CNFLCT),

and/or

IV. does not support the motor manufacturer of the motor present ("d7" - BLWR MFG CNFLCT),

and/or

V. is from an older furnace and is missing critical newer furnace shared data ("d8" - OLD SHARED DATA),

furnace shared data from the network (if valid) is used to control the furnace (see description of "network" under "If **no memory card present**" (item 1 above). Furnace shared data on the network will not be written or re-written from the memory card. If the furnace shared data on the network is valid, the appropriate fault for the memory card will be displayed at the active fault screen of the communicating thermostat and at the furnace seven-segment displays when in standby mode only (see fault code priority list). The homeowner will not be alerted (level 1 fault).

b. If neither the furnace shared data on the memory card is valid nor the furnace shared data on the network is valid, the fault code status is elevated. The homeowner is alerted via the communicating thermostat (level 2 fault) and the fault code *d1* (NO VALID SHARED DATA) is displayed at the communicating thermostat active fault screen and at the furnace seven-segment displays provided a high-

er priority fault is not also present (in which case the higher priority fault is displayed) (see fault code priority list).

c. If no furnace shared data is available on either the memory card or the network, the fault code "d1" (NO SHARED DATA) is displayed at the communicating thermostat active fault screen and at the furnace seven-segment displays provided a higher priority fault is not also present (in which case the higher priority fault is displayed) (see fault code priority list). The homeowner is alerted via the communicating thermostat (level 2 fault). Furnace shared data on the network will not be written or re-written from the memory card.

REPLACING THE FURNACE CONTROL

In the event that the furnace control must be replaced, the memory card must be detached from the original furnace control and retained with the furnace. Failure to save and connect the memory card properly to the replacement control may result in no operation or undesired operation of the furnace.

When replacing the furnace control, be sure to match the dipswitch settings of the original control on the replacement.

DO NOT CUT THE PLASTIC WIRE TIE USED AS A TETHER TO THE ATTACHED MEMORY CARD. DOING SO WILL DEFEAT THE PURPOSE OF RETAINING THE MEMORY CARD – WHICH COULD LEAD TO A LOSS OF CRITICAL DATA NECESSARY TO OPERATE THE FURNACE. THE CARD MUST STAY WITH THE FURNACE – EVEN WHEN THE FURNACE CONTROL (IFC) MUST BE REPLACED.

NEVER USE A CONTROL BOARD TAKEN FROM ANOTHER FURNACE AS A REPLACEMENT CONTROL FOR THIS FURNACE. FURNACE CONTROLS TAKEN FROM OTHER FURNACES MAY CONTAMINATE THE NETWORK WITH THE WRONG SHARED DATA WHICH CAN ONLY BE FIXED BY REPLACING THE MEMORY CARD WITH THE ORIGINAL MEMORY CARD FROM YOUR FURNACE OR A REPLACEMENT MEMORY CARD DESIGNED FOR YOUR FURNACE.

For communicating systems as a final confirmation of the correct shared data the model number should be verified by checking the furnace user menu under the sub menu titled "Unit Info." Make sure that the model number displayed in the menu matches the model number on the rating label. (**NOTE:** Wild cards will be shown in parenthesis. Example: RGFLE/F)-06(E/N)MCKS.)

DIPSWITCHES

NOTE: The integrated furnace control does not recognize switch setting changes while energized.

S3

S3-1 AND S3-2 – COOLING AIRFLOW SELECT – These dipswitches are used to select the appropriate cooling airflow based on the amount required. The switch settings do not affect cooling airflow when installed with a fully communicating condenser. In that case, the condenser supplies the information for cooling airflow which is preset at the factory and not adjustable.

For non-communicating systems or communicating systems with a non-communicating condenser (see section titled **SPECIAL CONFIGURATION – COMMUNICATING THERMOSTAT AND FURNACE WITH A NON-COMMUNICATING CONDENSER** of this document), the target cooling airflow will be determined by the adjustments of

S3-1 and S3-2. Furnaces with 1/2 HP motors will have a maximum target airflow setting of 1200 CFM. Furnace with 1 HP motors will have a maximum target airflow setting of 2000 CFM. The airflow achieved may be less than the target if the static pressure across the furnace is over 0.6" wc. Consult the cooling equipment instructions and documents for target airflow and adjust accordingly.

Cooling airflow for non-communicating systems can be adjusted approximately +/- 10% by using the cool trim adjustment dipswitches; S3-3 and S3-4. See Figure 40.

Cooling airflow for non-communicating systems is also affected by the settings of dipswitch position S5-2. This switch will determine the appropriate amount of airflow to be used for the low stage (1st stage) of cooling. See Table 17. More information can be found in the section titled S5 (S5-2).

Consult Figures 40, 41 and 42 and Table 17 for target airflow settings and adjustments based on the positions of the dipswitches S3-1, S3-2, S3-3, S3-4 and S5-2.

S3-3 AND S3-4 – COOLING AND HEAT-PUMP AIRFLOW ADJUSTMENT

– These dipswitches are used to adjust the cooling and heat-pump airflow for non-communicating systems slightly based on the user's preference.

S3-3 = "OFF", S3-4 = "OFF" – No adjustment.

S3-3 = "ON", S3-4 = "OFF" – +10% adjustment.

S3-3 = "OFF", S3-4 = "ON" – -10% adjustment.

S3-3 = "OFF", S3-4 = "OFF" – No adjustment.

**FIGURE 40
DIPSWITCH BANK S3**

* = FACTORY (DEFAULT) SETTING

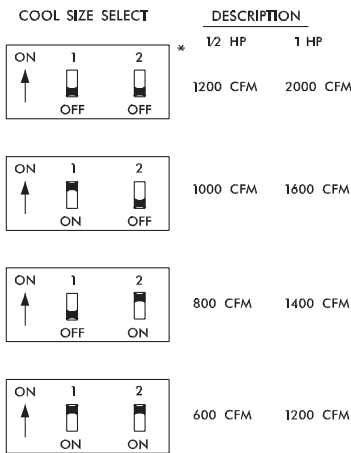

THESE SWITCHES ARE IGNORED ON COMMUNICATING SYSTEMS WITH COMMUNICATING CONDENSER

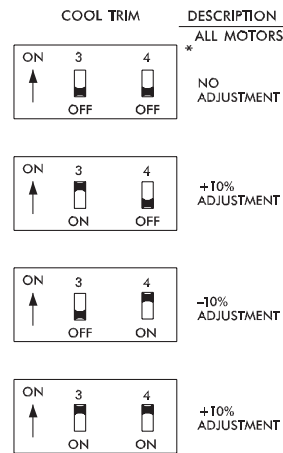

THESE SWITCHES ARE IGNORED ON COMMUNICATING SYSTEMS WITH COMMUNICATING CONDENSER

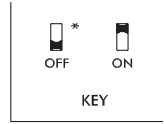

ST-A1163-01

TABLE 17
COOLING AIRFLOW SELECTIONS FOR NON-COMMUNICATING CONDENSERS

MODULATING FURNACE COOLING AIRFLOW RATES, 1/2 HP (1200 CFM Max) motor settings (applies only to systems configured with non-communicating condenser).						
S5-2	S3, Pos. 2	S3, Pos. 1	Y2 Single Stage	Y1, Low 2 Stage	Y1 & Y2 High 2 Stage	Notes
ON	OFF	OFF	1200 CFM	800 CFM	1200 CFM	3 Ton A/C
ON	OFF	ON	1000 CFM	500 CFM	1000 CFM	2.5 Ton
ON	ON	OFF	800 CFM	400 CFM	800 CFM	2 Ton A/C
ON	ON	ON	600 CFM	300 CFM	600 CFM	
OFF	OFF	OFF	1200 CFM	900 CFM	1200 CFM	3 Ton A/C
OFF	OFF	ON	1000 CFM	750 CFM	1000 CFM	2.5 Ton
OFF	ON	OFF	800 CFM	600 CFM	800 CFM	2 Ton A/C
OFF	ON	ON	800 CFM	450 CFM	800 CFM	
MODULATING FURNACE COOLING AIRFLOW RATES, 1 HP (2000 CFM Max) motor settings (applies only to systems configured with non-communicating condenser).						
S5-2	S3, Pos. 2	S3, Pos. 1	Y2 Single Stage	Y1, Low 2 Stage	Y1 & Y2 High 2 Stage	Notes
ON	OFF	OFF	2000 CFM	1000 CFM	2000 CFM	5 Ton A/C
ON	OFF	ON	1600 CFM	800 CFM	1600 CFM	4 Ton A/C
ON	ON	OFF	1400 CFM	700 CFM	1400 CFM	3.5 Ton
ON	ON	ON	1200 CFM	600 CFM	1200 CFM	3 Ton
OFF	OFF	OFF	2000 CFM	1400 CFM	1800 CFM	5 Ton A/C
OFF	OFF	ON	1600 CFM	1200 CFM	1800 CFM	4 Ton A/C
OFF	ON	OFF	1275 CFM	1050 CFM	1400 CFM	3.5 Ton
OFF	ON	ON	1200 CFM	900 CFM	1200 CFM	3 Ton

S4

S4-1 HEAT RISE ADJUST – This dip-switch is used to select desired temperature rise in the heating mode. The heat rise will always be closer to the target if the supply air sensor is properly installed (see sub-section in this section titled “SA SENSOR” below).

“OFF” will yield the maximum heat rise. (Target heat rise is 65°F but this value may vary slightly between low and high fire. Temp. rise will always be closer to the target if the “SA SENSOR” is properly installed.)

“ON” will increase the airflow to yield the minimum heat rise. (Target heat rise is 55°F but this value may vary slightly between low and high fire. Temp. rise will always be closer to the target if the “SA SENSOR” is properly installed.)

S4-4 FAN SPEED SELECT – This dip-switch is used to select the continuous fan speed when the furnace is configured with a non-communicating thermostat.

“OFF”

½ HP MOTORS = Approx. 600 CFM

1 HP MOTORS = Approx. 1000 CFM

“ON”

½ HP MOTORS = Approx. 1200 CFM

1 HP MOTORS = Approx. 2000 CFM

S4-2 and S4-3 -

FURNACE TEST and OPERATING MODES

FURNACE TEST SWITCHES

The Test Switches will place the IFC into a test mode, operating the furnace at continuous input rates of either 100% of full rate (maximum fire) or 40% of full rate (minimum fire). This is accomplished by setting the Test Switches as indicated in Table 18.

To enter the Furnace Test Mode, proceed as follows:

1. Switch the 115 volt power to the furnace OFF. **Do not change settings with control energized.**
2. Remove furnace blower door.
3. Position Test Switches S4-2 and S4-3 for the desired test mode.
4. Replace furnace blower door.
5. Switch the 115 volt power to the furnace ON.
6. Set the thermostat mode to HEAT, adjust the setpoint at least 4°F above room temperature to demand a call for heating.

When the furnace is powered with the test switches in a position other than modulating/single-stage or in 2-stage mode, the first call for heat within the first hour after power-up will instruct the furnace to perform as follows:

FIGURE 41
DIPSWITCH BANK S4 TEST MODE SELECT

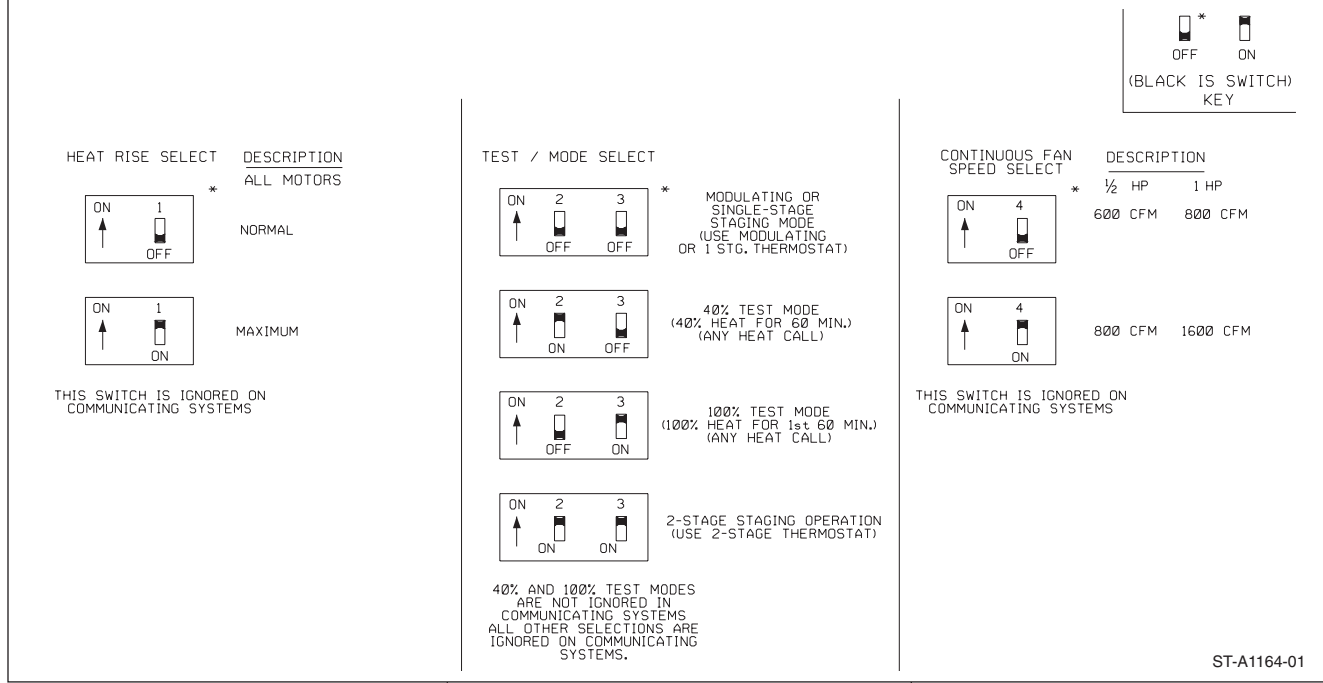

Switch (SW2-1)	Call	Voltage at "HUM"	Action
ON	COOL	24	Normal Cool (c or C)
ON	COOL	0	Dehum Cool (cd or Cd)
ON	Heat	24	Hum Contacts Closed.
ON	Heat	0	Hum Contacts Open.
OFF	COOL	24	Normal Cool (c or C)
OFF	COOL	0	Normal Cool (c or C)
OFF	Heat	24	Hum Contacts Closed.
OFF	Heat	0	Hum Contacts Open.

- To set the furnace for normal operation:**
1. Set the thermostat mode to OFF. Always allow furnace to complete the cool down cycle.
 2. Switch the 115 volt power to the furnace OFF. **Do not change settings with control energized.**
 3. Remove furnace blower door.
 4. Position dipswitches S4-2 and S4-3 for modulating/single-stage mode or 2-stage mode.
 5. Replace furnace blower door.
 6. Switch the 115 volt power to the furnace ON.
 7. Set the thermostat as desired.

1. Normal ignition sequence

2. A calibration cycle will be performed unless the Test Switches are set for Test 40%. The LED status indicator will flash "H" or "h" during the calibration cycle.

NOTE: The supply air sensor (field installed) is required for the furnace calibration cycle. If the air sensor is faulty, or not properly connected, the furnace will not attempt a calibration cycle and will operate on factory default parameters pre-programmed into the micro-processor.

After calibration, the furnace will then adjust to the desired Test capacity. This allows time for the technician to check steady-state operation and evaluate furnace performance.

The furnace will operate at the fixed Test capacity until one of the following conditions:

- A. The thermostat is satisfied and the call for heat is removed.
- B. The furnace has been in test mode continuously for sixty minutes, at which time the furnace control (IFC) will exit the test mode and proceed to normal heating operation as configured. Test mode can not be activated again unless line voltage power to the furnace is cycled off and back on. This is true even if the dipswitches remain configured to the test settings.

TABLE 18
SW2-2 AND SW2-3 MODE SELECTION SETTING

Mode	Switch S4-2 Position	Switch S4-3 Position
Modulating / Single-Stage	OFF	OFF
Test 40%	ON	OFF
Test 100%	OFF	ON
Two Stage	ON	ON

Note: The "Test 40%" and "Test 100%" settings will time out and become invalid one hour after power reset.

FIGURE 42
DIPSWITCH BANK S5 COOLING / O.D.D. SELECT

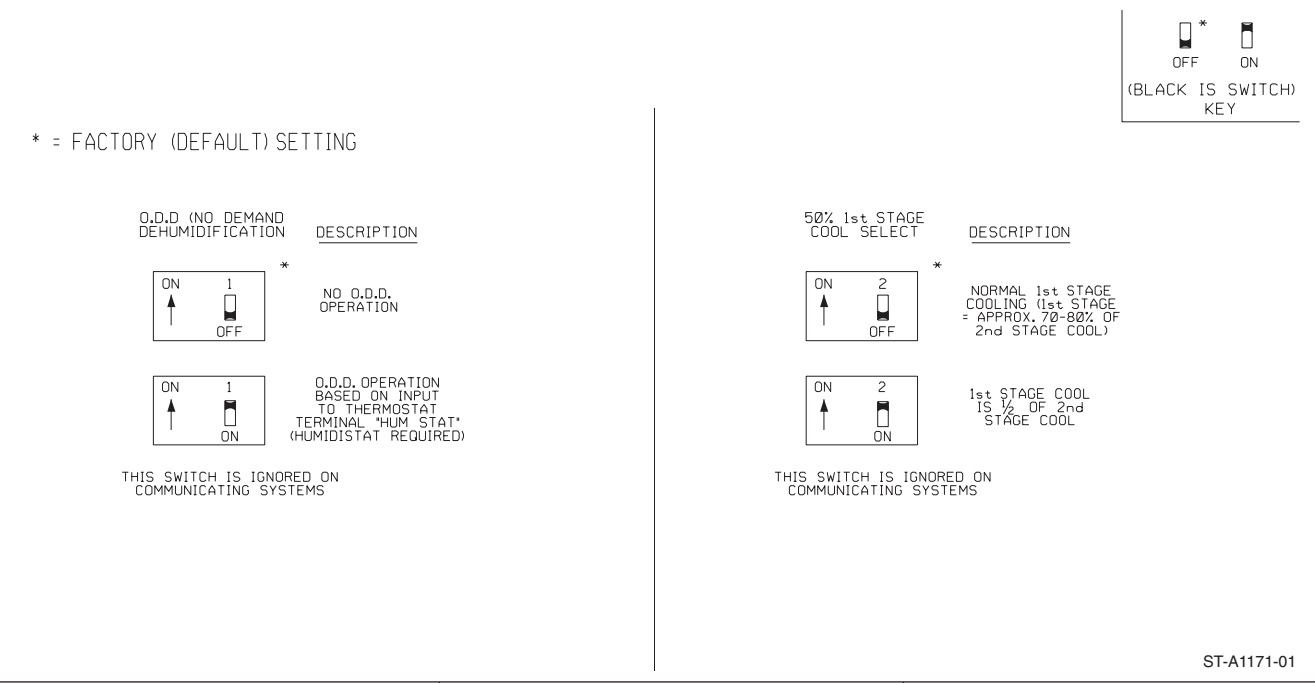

FURNACE OPERATION USING NON-COMMUNICATING MODULATING, SINGLE-STAGE, AND TWO-STAGE THERMOSTATS (CONSULT THE SECTION OF THIS DOCUMENT TITLED NON-COMMUNICATING THERMOSTATS FOR WIRING DIAGRAMS)

The modulating furnace is capable of operating with a single-stage or a two-stage thermostat as well as the modulating thermostat or fully communicating thermostat specified for use with the furnace. Fully communicating thermostat functions and operations are explained in detail in the sections of this manual titled **COMMUNICATING SYSTEMS** and **THERMOSTATS** (under the sub-section titled **COMMUNICATING THERMOSTATS**).

Based on the dipswitch settings of S4-2 and S4-3, the furnace will operate with either single-stage or two-stage thermostats as a modulating system using an algorithm that utilizes three distinct firing rates; 40%, 65% and 100% of the furnace heating capacity (See below for operation of each). See Figure 41 to determine which dipswitch settings are necessary for operation with a modulating, single-stage or two-stage thermostat.

See the section of this document titled **THERMOSTATS** (under the sub-section titled **NON-COMMUNICATING THERMOSTATS**) for information on how to wire the thermostats for each of the configurations below.

In non-communicating systems, the heating cycle is always initiated by a 24 volt signal on W1. When the controller senses 24 volts on W1, the following sequence occurs:

MODULATING FUNCTION:

(Modulating function with a non-communicating thermostat only applies when both switches **S4-2 and S4-3 are in the "OFF" position** and a non-communicating modulating thermostat (specified for use with the furnace) is installed as shown in Figures 53-55.)

After the warm-up period, the furnace will respond to the thermostat demand by adjusting the gas valve pressure and blower speed between 40% and 100% of maximum heating capacity.

TWO-STAGE FUNCTION:

(Two-stage function only applies when both switches **SW2-2 and SW2-3 are in the "ON" position** and a two-stage thermostat is installed as shown in Figure 57.)

After the blower on-delay period, the furnace will respond to the thermostat demand by adjusting the gas valve pressure and blower heating speeds to the "W" signal values. "W1" only = 40% gas valve pressure and blower heating speed. "W2" = 65% gas valve pressure and blower heating speed for the first five minutes and 100% thereafter. Also, if the call for heat ends, the furnace terminates at the present rate.

SINGLE-STAGE FUNCTION ("W" signal only) :

(Single-stage function only applies when both switches **S4-2 and S4-3 are in the "OFF" position** and a single-stage thermostat is installed as shown in Figure 56.)

After the blower on-delay period, the furnace will respond to the thermostat demand by altering the gas valve pressure and blower speed as follows:

Phase 1: 0 to 5 minutes = 40% of furnace capacity (gas valve output and blower speed)

Phase 2: 5 to 12 minutes = 65% of furnace capacity (gas valve output and blower speed)

Phase 3: After 12 minutes = 100% of furnace capacity (gas valve output and blower speed)

NOTE: If the call for heat ends during any phase, the furnace will terminate immediately at the firing rate of that phase.

FIGURE 43
DIPSWITCH BANK S1 HEAT AIRFLOW ADJUSTMENT

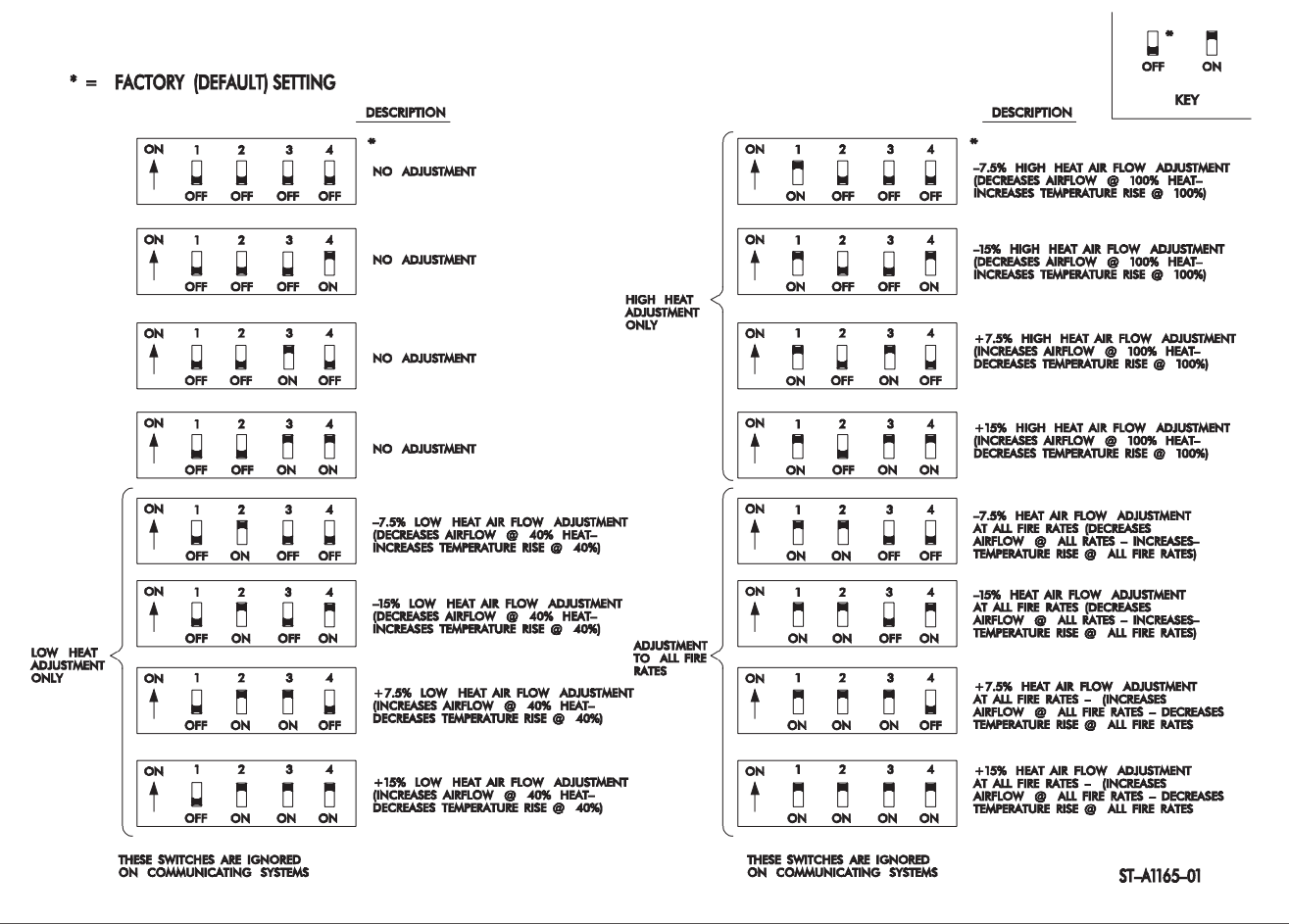

S5

S5-1 = ODD “ON” or “OFF” select. This switch will ignore the input from the 24 volt terminal labeled “HUM STAT” during cooling when in the “OFF” position. However, the “HUM STAT” input is always read in the heating mode to turn on and off the humidifier relay.

When in the “ON” position, the dehumidification feature will become active and it will be necessary to install a humidistat to the “HUM STAT” terminal as discussed and shown in wiring diagrams in the section of this manual titled “*HUMIDIFICATION AND DEHUMIDIFICATION*” of this document. Failure to install a humidistat to the “HUM STAT” terminal with dip-switch SW2-1 in the “ON” position will cause the cooling speed airflow to be reduced to the dehumidification speed.

S5-2 - For most cooling operation, leave dip switch SW2-4 in the “OFF” position. This will enable the furnace operation with most two-stage, non-communicating cooling equipment. Actual SEER values will vary and depend on the equipment combination. Consult the specifications sheets and installation instructions of the cooling equipment purchased for a listing of the SEER ratings for a specific combination.

Placing S5-2 in the “ON” position will establish the low (Y1) cooling airflow at ½ of the max cool (Y2) airflow. This setting will be useful with cooling systems where two compressors are used to control two cooling stages (one compressor for first stage and two compressors for second stage).

S1

Dipswitch bank S1 is used to fine-tune the airflow in the heating mode. The switches of bank S1 can be set to adjust either the minimum heat rate airflow or the maximum heat rate airflow or both. Also, every firing rate in between these points will be adjusted accordingly.

S1 will allow for airflow adjustments at high altitude, improper temperature probe locations, or no temperature probe applications. If the temperature rise range needs adjustment, the technician must use separate temperature probes to determine the rise range and adjust the airflow using S1’s dip switches until the rise range is as close as possible to the target temperature rise (65°F or 55°F – adjusted at dipswitch SW1-3).

NOTE: All dip switches on S1 will be shipped in the “OFF” position.

See Figure 43 for Heating Adjustment Selections.

FIGURE 44
DIPSWITCH BANK S2 TERMINATION AND BIAS SELECTIONS

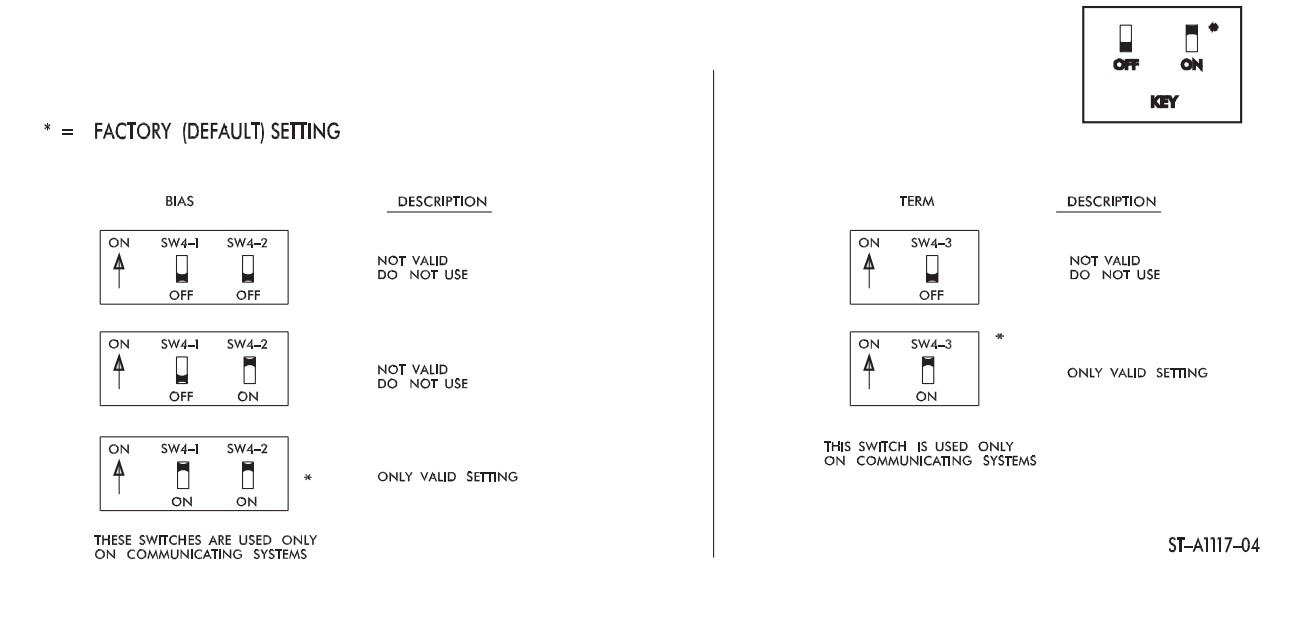

SW4 BIAS / TERMINATION

These dipswitches will not be used for first generation controls. They are designed to be used for future generations of ClimateTalk which may support multiple networks. ***For current installations, all three of the dipswitches in bank SW4 must be in the "ON" position. If not, the system may not be able to communicate.***

DUAL SEVEN-SEGMENT DIAGNOSTIC DISPLAY

The dual seven-segment diagnostic display will either display the status of the system (e.g. "H" for Heat) or a diagnostic error code in the event of an active fault. Fault and status codes and their meanings can be determined from Table 19. For detailed information for each fault code refer to the TROUBLESHOOTING section of this manual. For communicating systems, the fault code and a description can be found in the thermostat "Active Fault" display area. (See the section of this document titled "ACTIVE FAULT DISPLAY" under COMMUNICATING SYSTEMS for more information).

The rightmost decimal on the display will blink one time for every 100 CFM of expected airflow whenever the blower is operating. If the value is actually less

than 50 CFM above any increment of 100, the value will be rounded to the lesser 100 value and the lesser value will be displayed. For example, if the actual CFM is 1049, the decimal will blink ten times. If the actual CFM value is 1051, the decimal will blink eleven times. For better resolution, a service tool or communicating thermostat is required and the expected CFM can be determined within a resolution of 10 CFM. (See the section of this manual titled "USER MENUS" under "STATUS 1" or "STATUS 2" submenu "BLOWER CFM").

FAULT CODE BUFFER

Upon power reset, the last five fault codes from the furnace will be displayed on the seven-segment display. These will be displayed in chronological order from newest (displayed first) to oldest (displayed last).

For communicating systems, the fault code buffer can also be read at the communicating thermostat inside the furnace User Menus. The most recent six fault codes are stored. Also displayed is the number of days since each fault code was recorded.

NOTE: The following fault codes will not be stored back-to-back in the fault buffer. These will only be stored in the buffer if the previous fault stored was a different fault. 82, 11, 45, 46 & 57.

CLEARING DIAGNOSTIC FAULT CODES FROM THE BUFFER

To clear the fault codes in the fault buffer, push and hold down the "Fault Recall" button for 3 seconds. When this is done, the right-most seven-segment display will energize the upper and lower horizontal segments for four seconds as confirmation that the fault codes have been cleared from the buffer. Be sure to return the switch to the original position after clearing the faults.

Faults can also be cleared at the furnace User menu under the *Fault Hist* selection. The seven-segment displays will again operate as described above.

TABLE 19
LIST OF FAULT CODES AND NORMAL OPERATION CODES

FAULT CODES / MESSAGES			
MESSAGE TO TECHNICIAN at TSTAT (note: Fault Code Number and Fault Code Text are displayed in two separate regions of T-Stat display)			
FAULT CODE #	TEXT MESSAGE	MESSAGE TO HOMEOWNER	CODE NUMBER (displayed furnace)
d1	NO SHARED DATA	"Call For Service" & "CHECK FURNACE"	d1
d4	MEM CARD INVALID	(None)	d4
d5	CARD-HRD CNFLCT	(None)	d5
d6	BLWR HP CNFLCT	"Call For Service" & "CHECK FURNACE"	d6
d7	BLWR MFG CNFLCT	"Call For Service" & "CHECK FURNACE"	d7
d8	OLD SHARED DATA	(None)	d8
d8	OLD SHARED DATA	"Call For Service" & "CHECK FURNACE"	d8
h	GAS HT ON-NO V	(None)	h (steady)
10	IGN 1 HR RTRY	"Call For Service" & "CHECK FURNACE"	10
11	FAILED IGNITION	(None)	11
12	LO FLAME SENSE	(None)	12
13	FLAME LOST	(None)	13
14	UNEXPTED FLAME	"Call For Service" & "CHECK FURNACE"	14
22	MAIN LIMIT OPEN	(None)	22
23	HALC LIMIT OPEN	"Call For Service" & "CHECK FURNACE"	23
26	LINE_NTRL RVRSD	"Call For Service" & "CHECK FURNACE"	26
33	MRLC OPEN	"Call For Service" & "CHECK FURNACE"	33
44	LPC CLOSED	"Call For Service" & "CHECK FURNACE"	44
45	LPC OPEN	"Call For Service" & "CHECK FURNACE"	45
46	LPC OPEN	"Call For Service" & "CHECK FURNACE"	46
55	HPC CLOSED	"Call For Service" & "CHECK FURNACE"	55
57	HPC OPEN	"Call For Service" & "CHECK FURNACE"	57
60	BLWR FLT-RUN	(None)	60
61	BLWR FLT-NO RUN	"Call For Service" & "CHECK FURNACE"	61
66	BLOWER OVRSPED	(None)	66
68	NO BLWR COMM	"Call For Service" & "CHECK FURNACE"	68
71	NO INDUCER COMM	"Call For Service" & "CHECK FURNACE"	71
77	NO GV FEEDBACK	"Call For Service" & "CHECK FURNACE"	77
93	CONTROL FLT	"Call For Service" & "CHECK FURNACE"	93

NORMAL OPERATION CODES / MESSAGE S	
CODE DISPLAYED AT FURNACE	DESCRIPTION (Neither a code or message is displayed at the thermostat number only is displayed at the furnace control.)
0	Standby mode - no thermostat calls, no active faults.
c	Low-stage cooling (not displayed in communicating modes)
C	High-stage cooling (displayed during both low and high cooling in communicating modes)
F	Continuous Fan Operation
hp	Low-stage heat-pump operation
HP	High-stage heat-pump operation
H (steady)	Furnace heat with valid modulation signal or Communicating heat signal
h (steady)	Heat call with no valid modulation signal (legacy modes only)

NOTE: To clear current fault codes in the furnace control buffer, push and hold dc button (SW1) for three seconds. The right-most Seven-Segment Display will energize horizontal members (turned vertical in the application) for four seconds as confirmations have been cleared. This will clear faults in the buffer displayed at power-up on the thermostat user menu displayed at the thermostat.

NOTE: The following fault codes will not be stored back-to-back in the fault buffer. These will only be stored in the buffer if the previous fault stored was a different fault. 11, 45, 46 and 57.

COMMUNICATING SYSTEMS

The modulating furnace is capable of communicating with a thermostat and condenser to improve cooling and heat-pump airflow, displaying active faults and active furnace information at the thermostat and improved diagnostics and troubleshooting.

WIRING A FURNACE FOR COMMUNICATIONS.

Maximum wire lengths and notes about wiring communicating systems are noted below.

MAXIMUM COMMUNICATING WIRE LENGTHS (1, 2, R & C)

Max Wire Length – Thermostat to Furnace = **100 FT @ 18 AWG***

Max Wire Length – Furnace to Condenser = **125 FT @ 18 AWG***

Notes:

1. When using twisted pairs, be sure the wires connected to pins labeled "1" (recommended wire color = green) and "2" (recommended wire color = yellow) are a twisted pair.
2. Wires may be solid or stranded..
3. *Wire gage smaller than 18 AWG is not approved or recommended for this application.
4. When using existing wire from a previous installation, be sure to trim the tip of the wire back past the insulation and strip a small amount of insulation from the wire to expose clean new copper for the communicating connections. Fresh copper must be exposed when making the communicating connections or communications may not be properly established.

Figure 45 is the wiring diagram for connecting the furnace to an approved ClimateTalk communicating thermostat and approved Rheem or Ruud communicating condenser.

The only approved configuration is to install dedicated wires directly from the furnace to the thermostat and a separate set of dedicated wires directly from the furnace to the condenser. Note: The only approved configuration requires that four dedicated wires (1, 2, R and C) be installed from the furnace to the condenser.

FIGURE 45
WIRING DIAGRAM – COMMUNICATING CONFIGURATION

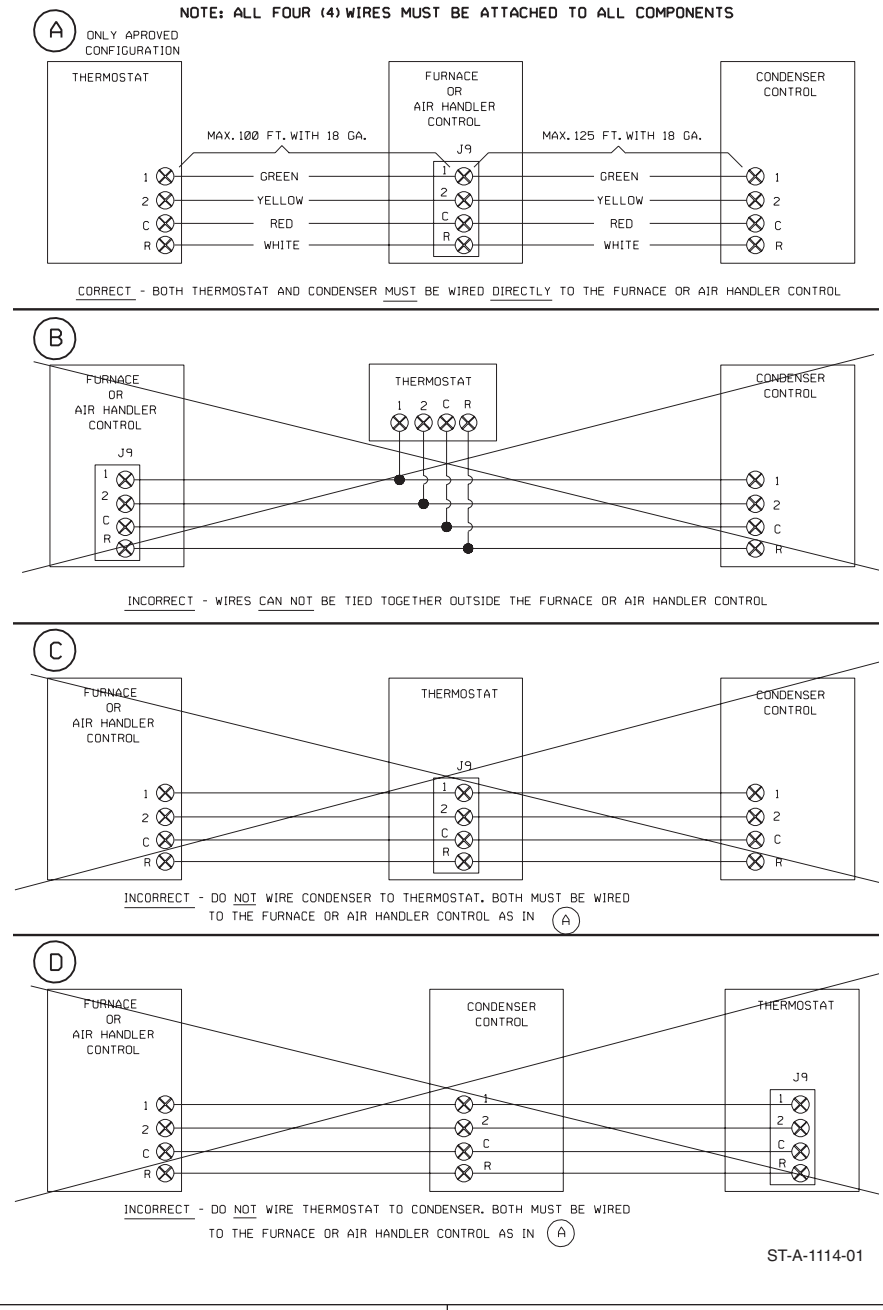

STARTUP FOR SYSTEMS CONFIGURED WITH COMMUNICATIONS

⚠ WARNING

INSTALLATION OF LINE VOLTAGE AND GAS MUST BE PERFORMED ACCORDING TO INSTRUCTIONS WRITTEN IN THIS MANUAL. FAILURE TO DO SO COULD RESULT IN INJURY OR DEATH.

When the furnace is configured for communications, the components on the network (i.e. furnace, thermostat and condenser) must establish communications before engaging a heat (or other) thermostat demand. The procedure for establishing communications is automatic and is described below. Once communications is established, the start-up procedure will be the same as the general start-up instructions described in the section of this manual titled **START-UP PROCEDURES**.

Once the communicating wiring is properly installed and the furnace is connected to line voltage, the system can be turned on. The thermostat will display the following text:

“SEARCHING”

is displayed several times for several seconds. Next, the text

“FURNACE FOUND”

and

“AIR CONDITIONER FOUND”

or

“HEAT PUMP FOUND”

(depending on which is installed in the system) will be displayed. The process can take several minutes (up to a maximum of 30) to complete. If these messages are not displayed within 30 minutes after energizing the system, communications can not be established. There are many reasons why communications may not be established – including improper settings of the “TERM” and “BIAS” switches (see BIAS / TERMINATION) and improper wiring (see **WIRING A FURNACE FOR COMMUNICATIONS** above).

The order in which these messages will be displayed will depend on which components are energized first. The order listed here assumes that the furnace and condenser are energized at the same time. If not, the order of display will be in the order that the components are turned on.

When the system has found all necessary components, the text area of the communicating thermostat will go blank. This is an indicator that the system is operating properly. Proceed by engaging a typical thermostat call to determine if operation is correct as described in the section of this book titled START UP PROCEDURES” to test heating, cooling and fan operation and to make necessary adjustments.

NOTE: When a communicating condenser is installed with the system, a capital “C” will be displayed at the furnace seven-segment display for both low & high cooling stages.

NOTE: If the blower motor reaches its maximum power level during the first three minutes of blower operation after power up, a fault code “66” will be displayed. This may be an indicator of excessive static pressure or inadequate duct sizing. The message will not be displayed again after the first three minutes of blower operation.

CONTINUOUS FAN OPERATION IN COMMUNICATING MODE

NOTE: It is important for the installer to run the communicating system at the maximum cooling rate (with communicating condenser attached) so that the furnace can determine the maximum cooling airflow. This value is used to calculate the continuous fan airflow (see below) and defrost airflow (for communicating dual-fuel systems).

Continuous fan operation will always depend on the selection (Hi, Med, Low) made at the communicating thermostat for the continuous fan speed (see installation instructions for the thermostat). However, during the first few operations of continuous fan, the blower speed will be limited to a maximum of 600 CFM for ½ HP motors (60KBTU and 75KBTU) and 1000 CFM for 1 HP motors (90KBTU, 105KBTU and 120KBTU).

This will continue until the high cooling call information is provided from the condenser. Once the max cooling CFM value has been transmitted by the condenser (condenser must reach high stage – in heat pump or cooling), the continuous fan will then have a maximum CFM value equal to the max cooling airflow from the condenser. The Hi, Med and Low selections for continuous fan will be based on max CFM of the condenser with Hi continuous fan speed equal to the high speed CFM of the cooling/HP condenser.

NOTE: When faults are cleared in the furnace “SETUP” user menu, the continuous fan CFM will be restored to factory default (Max = 600 CFM for 1/2 HP and 1200 CFM for 1 HP). These values will again be used to calculate continuous fan airflow until a cooling call has been established and a communicating condenser sends a fan demand to the furnace control.

ACTIVE FAULT CODES WITH COMMUNICATING SYSTEMS

Two levels of fault codes exist: (1) Non-critical and (2) Critical. In general a non-critical fault permits all (or nearly all) operations to proceed and a critical fault prevents all (or nearly all) operations from proceeding. Detailed explanations are given for each fault code and how to diagnose and troubleshoot problems by fault code displayed in the “TROUBLESHOOTING” section of this manual.

Active faults of either level will be displayed at the thermostat in the “ACTIVE FAULT” area of the thermostat. To enter the furnace “ACTIVE FAULT” area using a communicating thermostat, see the installation and operation instructions for that thermostat.

FURNACE USER MENUS

NOTICE: ALL TEMPERATURE VALUES DISPLAYED IN USER MENUS ARE DISPLAYED IN DEGREES FAHRENHEIT AT ALL TIMES. THIS IS TRUE EVEN IF THE THERMOSTAT IS SELECTED TO CELCIUS (C.). USER MENUS CAN NOT DISPLAY TEMPERATURES IN CELCIUS.

Systems configured for communications will have some advantages over traditional control (24VAC thermostats) systems. One advantage is that a variety of information that can be useful for configuring the furnace/system and diagnostic/troubleshooting information can be displayed at the thermostat.

The bulk of this information can be found inside the user menus. The procedure for entering (and exiting) the user menus will vary depending on the thermostat or service tool that is used. To enter, navigate or exit the furnace “USER MENU”s using a communicating thermostat, see the installation and operation instructions for that thermostat.

Navigating the user menus is straight-forward. The menu follows the logic tree shown in Figure 46 (a & b).

NOTE: There may be a delay of several seconds when accessing the user menu or sub-menu. This is normal.

FIGURE 46a
MENU TREE

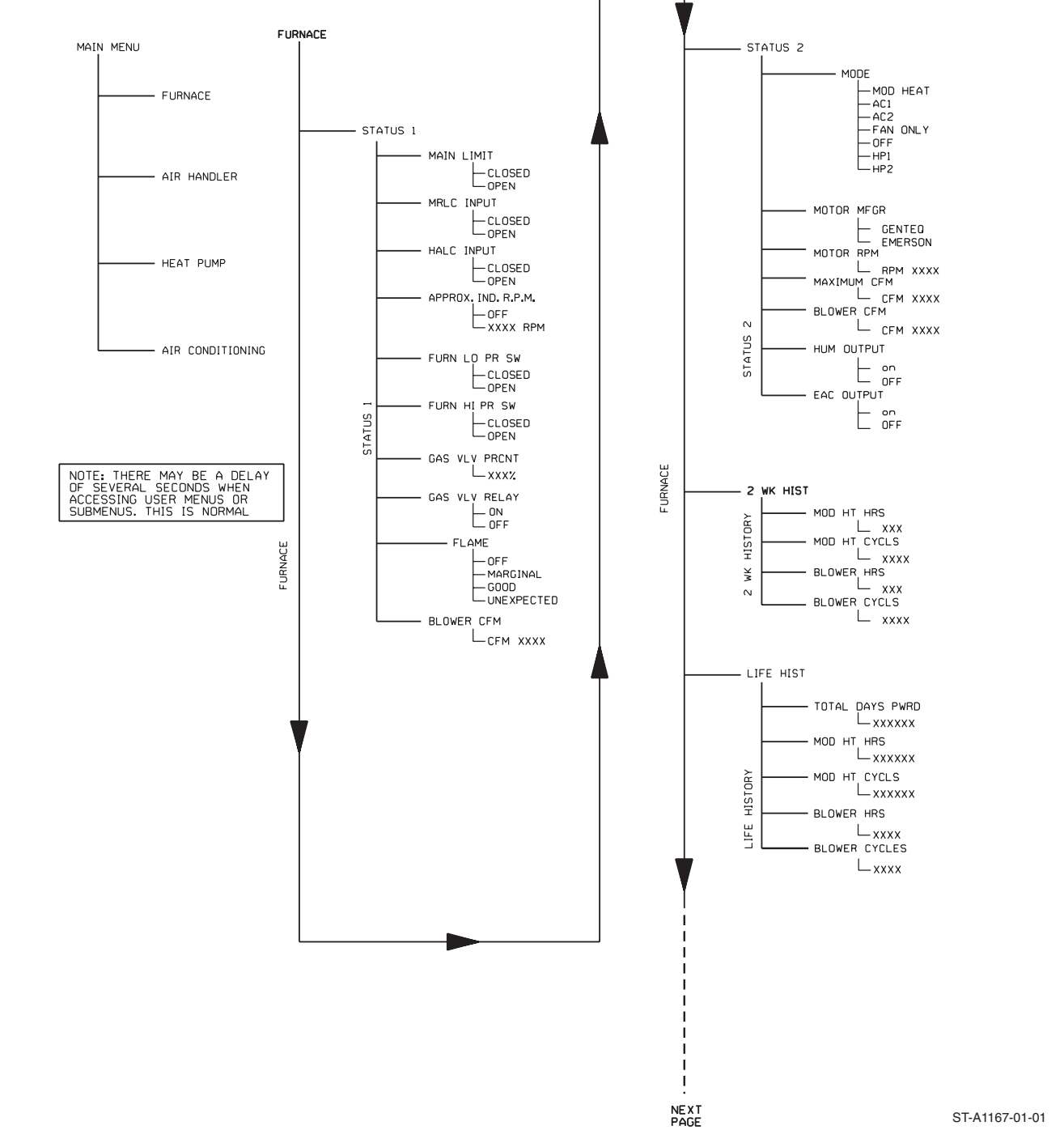

The thermostat menus give active information for various parameters and permit some installation options to be selected.

Note: Supply Air (SA) and Return Air (RA) temperature readings may not be accurate in standby mode. These should only be read and used when the blower is running in heat, cool or other modes.

“STATUS 1” menu – This menu gives information about the status of certain furnace components and features.

- 1. MAIN LIMIT** – Indicates the state of the main limit – either opened or closed. The normal state is closed. An open limit can be an indicator of excessive static pressure in the ventilation duct.
- 2. MRLC INPUT** – Indicates the state of the Manual Reset Limit Control (MRLC) – either opened or closed. The normal state is closed. These switches are sometimes referred to as “Roll-Out” controls or limits. When one or more of these limits has opened, a flame has rolled into

the vestibule. This event should rarely (if ever) happen but can be an indicator that the exhaust flue is blocked.

- 3. HALC INPUT** – Indicates the state of the Heat Assisted Limit Control (HALC) – either opened or closed. The normal state is closed. This limit switch is only present on downflow/horizontal models and can often be an indicator that the main blower has stopped turning unexpectedly when opened.

FIGURE 46b
MENU TREE – CONTINUED

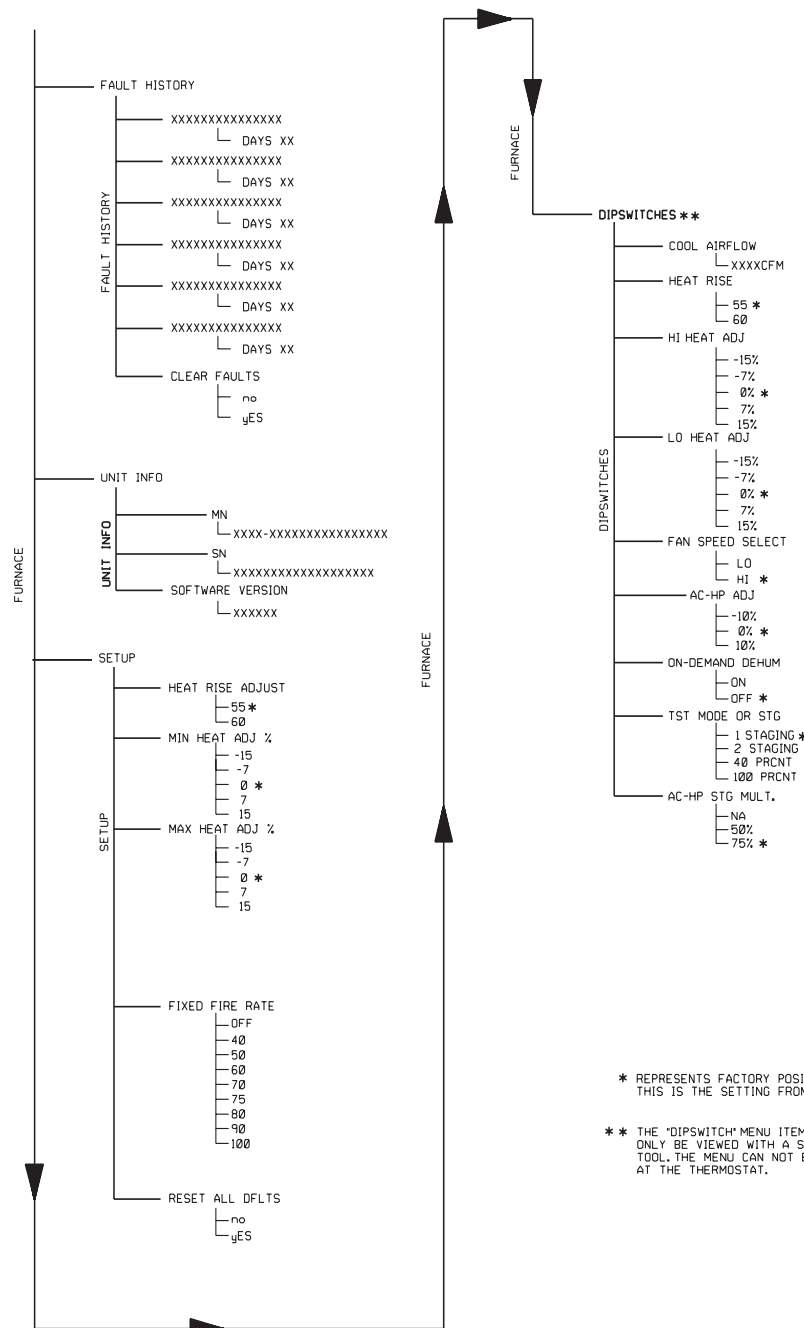

* REPRESENTS FACTORY POSITION.
THIS IS THE SETTING FROM THE FACTORY.

** THE "DIPSWITCH" MENU ITEM CAN ONLY BE VIEWED WITH A SERVICE TOOL. THE MENU CAN NOT BE VIEWED AT THE THERMOSTAT.

ST-A1167-01-02

- 4. **APPROX IND RPM** – Indicates the approximate speed of the inducer in RPM. The value is estimated and should be close but will not be perfectly accurate. When the inducer is off the text "OFF" will be displayed.
- 5. **FURN LO PR SW** – Indicates the state of the Low Pressure Control (LPC) (also known as low pressure switch) – either OPEN or CLOSED.
- 6. **FURN HI PR SW** – Indicates the state of the High Pressure Control (HPC) (also known as high pressure switch) – either OPEN or CLOSED.

- 7. **GAS VLV PRCNT** – Indicates the firing rate of the modulating gas valve. This value can be any number between 40% and 100% depending on the thermostat demand.
- 8. **GAS VLV RELAY** – Indicates the state of the gas valve relay –either ON or OFF. ON indicates that the main gas valve solenoid is engaged. Any time the indication is ON, flame should be present.
- 9. **FLAME** – Indicates the presence of a flame. The possibilities are

- "OFF", "MARGINAL", "GOOD" and "UNEXPECTED". A marginal flame can be an indicator that the flame sense rod needs to be cleaned. "UNEXPECTED" flame is a serious condition and must be dealt with immediately by a professional, licensed HVAC technician.
- 10. **BLOWER CFM** – Indicates the CFM that the furnace control requests from the blower motor. This value may vary somewhat from the actual values, but it

should be very close. The value can also be tracked through the blinking decimal point on the seven segment displays at the furnace control (although with not as much resolution).

“**STATUS 2**” menu – This menu also gives information about the status of certain furnace components and features.

1. **MODE** – Indicates the current state of operation of the furnace. The possibilities are listed below:
 - a. **MOD HEAT** – Heat operation
 - b. **AC** – Air conditioning operation.
 - c. **FAN ONLY** – Continuous fan operation.
 - d. **HP** – Heat-pump operation.
2. **MOTOR MFGR** – Indicates the manufacturer of the main air-circulating blower motor. At the time of this publication there are two possibilities; RGBLT for Regal Beloit (formerly GE) and EMERSON.
3. **MOTOR RPM** – Indicates the RPM of the main circulating air blower.
4. **MAXIMUM CFM** – Indicates the maximum CFM that the main circulating air blower can deliver.
5. **BLOWER CFM** – Indicates the output of airflow in CFM of the main circulating air blower.
6. **HUM OUTPUT** – Indicates when the humidifier output is turned on.
7. **EAC OUTPUT** – Indicates when the electronic air cleaner output is turned on.

“**2 WK HIST**” menu – This menu gives information about the number of cycles and the amount of time spent in various modes of operation over the last 14 days.

NOTE: For both 2 WK & LIFE HIST, the value saved prior to power loss may not include information from the last hour of operation. This is because the information is only stored once every hour.

1. **MOD HT HRS** – Indicates the number of hours of operation of gas heating operation rate in the last 14 days.
2. **MOD HT CYCLS** – Indicates the number of cycles of operation (i.e.: the number of times it turned on and off) of gas heat operation in the last 14 days.
3. **BLOWER HRS** – Indicates the number of hours of continuous fan operation in the last 14 days.

4. **BLOWER CYCLS** – Indicates the number of cycles of operation (i.e.: the number of times it turned on and off) of the continuous fan operation in the last 14 days.

“**LIFE HIST**” menu – This menu gives information about the number of cycles and the amount of time spent in various modes of operation over the life of the furnace.

NOTE: For both 2 WK & LIFE HIST., the value saved prior to power loss may not include information from the last hour of operation. This is because the information is only stored once every hour.

1. **TOTAL DAYS PWRD** – Indicates the total number of days that the furnace has been powered. This number is not affected by any thermostat operation.
2. **MOD HT HRS** – Indicates the number of hours of operation of gas heating operation over the life of the furnace.
3. **MOD HT CYCLS** – Indicates the number of cycles of operation (i.e.: the number of times it turned on and off) of gas heat operation over the life of the furnace.
4. **BLOWER HRS** – Indicates the number of hours of continuous fan operation over the life of the furnace.
5. **BLOWER CYCLS** – Indicates the number of cycles of operation (i.e.: the number of times it turned on and off) of the continuous fan operation over the life of the furnace.

“**FAULT HISTORY**” menu – This menu gives information about the six most recent faults experienced by the furnace. The most recent fault is displayed upon entering the menu. Three seconds later the text “**DAYS**” is displayed followed by a number. The number indicates the number of days since that fault was experienced.

The faults can be viewed in order of occurrence. Pressing the down arrow key once will permit viewing of the next most recent fault. Pressing the key again will display the second most recent fault and so on.

If no fault present in the memory, the text “**NO FAULT**” and “**DAYS 0**” will be displayed. It is possible that there will be less than six faults stored (if less than six faults have occurred since installation or clearing of faults). In this case, the existing faults will be displayed in the order of occurrence and the remaining faults will be displayed as “**NO FAULT**” and “**DAYS 0**”.

The final item in this menu is “**CLEAR FAULTS**”. The options are “**YES**” and “**NO**”. This item permits the faults to be cleared so all six positions will display “**NO FAULT**” and “**DAYS 0**”.

When faults are cleared, the right seven segment display on the furnace control will flash the upper and lower horizontal bars once.

Note that the “**FAULT HISTORY**” only accumulates days when power is applied to the furnace control board. For example, if a fault actually occurred ten days ago and the furnace was not powered for two of the ten days, the fault will be displayed with the text “**DAYS 8**” instead of “**DAYS 10**” is displayed to indicate the number of days since the fault occurred.

“**UNIT INFO**” menu – This menu gives information about the furnace.

1. **MODEL NUMBER (MN)**
2. **SERIAL NUMBER (SN)**
3. **SOFTWARE VERS.**

“**SETUP**” menu – This menu permits the field adjustment of certain parameters of the furnace. The selected values will be saved in memory even when power is lost and restored. The procedure for making changes in the furnace setup menu will vary depending on the thermostat or service tool that is used. To enter, navigate, make changes to or exit the furnace “**SETUP**” menu using a communicating thermostat, see the installation and operation instructions for that thermostat.

1. **HEAT RISE ADJ*** – The value of the heat rise can be changed to reflect the comfort of the homeowner. The value can be changed between “**NOM +10**” (nominal or mid temperature rise plus 10 degrees F) and “**NOM**” (nominal or mid temperature rise). Additional adjustment can be to low and high heating rates (and all points between) at the “**MIN HEAT ADJ**” and “**MAX HEAT ADJ**” menu items in items 2 and 3 below.

The temperature rise values listed are for reference only. The actual measured temperature rise may be different than expected by several degrees.

The default factory setting for the heat rise is “**NOM +10**”.

***ALL TEMPERATURES CAN BE DISPLAYED ONLY IN FAHRENHEIT VALUES**

2. **MIN HEAT ADJ** - This selection permits the adjustment of the low heat airflow. Operation of this selection is exactly as with the dipswitches at SW3 at the furnace control. The low heat rise can be changed by increasing or decreasing the airflow slightly. Adjustments are -15%, -7.5%, 0, +7.5% and +15%. Note that when a low heat adjustment is made, the low heat rate is adjusted and all points between low and high heat will be adjusted proportionally with the greatest adjustment on the low end and the least adjustment on the high end. **IMPORTANT:** Note that increasing the airflow will decrease the temperature rise and decreasing the airflow will increase the temperature rise. This may not be obvious at first.

The default factory setting for the min heat adjustment is "0".

3. **MAX HEAT ADJ** - This selection permits the adjustment of the high heat airflow. Operation of this selection is exactly as with the dipswitches at SW3 at the furnace control. The high heat rise can be changed by increasing or decreasing the airflow slightly. Adjustments are -15%, -7.5%, 0, +7.5% and +15%. Note that when a high heat adjustment is made, the high heat rate is adjusted and all points between high and low heat will be adjusted proportionally with the greatest adjustment on the high end and the least adjustment on the low end. **IMPORTANT:** Note that increasing the airflow will decrease the temperature rise and decreasing the airflow will increase the temperature rise. This may not be obvious at first.

The default factory setting for the max heat adjustment is "0".

4. **FIXED FIRE RATE** – This feature will temporarily fix the gas heating fire rate to the selection desired. The selected rate will be applied to the present heat call only. If there is no heat call already present when the selection is attempted, the system will not permit the firing rate to be fixed at the user menu. The firing rate and blower will be fixed at the selected rate for the duration of the existing heat call or a maximum of two hours (whichever comes first). This feature should only be used for installation, diagnostic, adjustment and troubleshooting purposes by an experienced licensed technician. Selectable firing rates are 40%, 50%, 60%, 70%, 75%, 80%, 85%, 90% and 100%.

5. **RESET ALL DFLT**s – This selection restores all items in the "SETUP" menu to the factory default selections. If "YES" is selected, all settings in this menu will be lost.

NOTE: When faults are cleared in the furnace "SETUP" user menu, the continuous fan CFM will also be restored to the factory default setting. (See Continuous Fan Operation in Communicating Mode.)

BELOW USER MENU IS USED FOR NON-COMMUNICATING SYSTEMS ONLY

"DIPSWITCH" menu – This menu permits viewing of the dipswitch selections. It is a way to read the dipswitch selections without the need of translating the settings manually.

Note: The "DIPSWITCH" menus will not be displayed at the thermostat. They are invisible to the thermostat and can not be displayed. These menus can only be viewed with the field service tool. The reason is that dipswitch selections do not generally affect operation of the furnace when using the communicating mode of operation.

NOTE: The integrated furnace control does not recognize switch setting changes while energized. To change settings, remove power to the board by turning off the disconnect or switch to the furnace control or removing power at the breaker, make changes, then return power.

1. **COOL AIRFLOW** – Displays the value of the cooling airflow selected. See the section of this manual titled "DIPSWITCH" under "SW1" (SW1-1 and SW1-2) for details and selections.

2. **HEAT RISE*** – Displays the value selected for the heat rise (either nominal or nominal plus ten degrees F). See the section of this manual titled "DIPSWITCH" under "SW1" (SW1-3) for details and selections.

*ALL TEMPERATURES CAN BE DISPLAYED ONLY IN FAHRENHEIT VALUES

3. **HI HEAT ADJ** – Displays the value selected at SW3, positions 4 thru 6. It is the adjustment of the high heat rate airflow. See the section of this manual titled "DIPSWITCH" under "SW3" (SW3-4 thru SW3-6) for details and selections.

4. **LO HEAT ADJ** – Displays the value selected at SW3, positions 1 thru 3. It is the adjustment of the low heat rate airflow. See the section of this manual titled "DIPSWITCH" under "SW3" (SW3-1 thru SW3-3) for details and selections.

5. **FAN SPD SELECT** – Displays the fan speed selected. See the section of this manual titled "DIPSWITCH" under "SW1" (SW3-4) for details and selections.

6. **AC-HP ADJ** – Adjusts the cooling or heat-pump airflow slightly to change or adjust the temperature rise slightly. See the section of this manual titled "DIPSWITCH" under "SW1" (SW1-5 and SW1-6) for details and selections.

7. **ON DEMAND DEHUM** – Toggles the dehumidification feature on or off. See the section of this manual titled "DIPSWITCH" under "SW2" (SW2-1) for details and selections.

8. **TST MODE OR STG** – Displays the operation configuration based on the dipswitch selections. These selections are explained in detail in the section of this manual titled "DIPSWITCH" under "SW2" (SW2-2 and SW2-3). Further description follows:

1 STAGING – (SW2-2 = OFF and SW2-3 = OFF) Represents either fully modulating operation (when valid signal is present) or staging operation when a single stage thermostat is connected.

2 STAGING – (SW2-2 = ON and SW2-3 = ON) Represents timed staging operation with a two-stage thermostat.

40 PRCNT TEST – (SW2-2 = ON and SW2-3 = OFF) Represents the mode of operation which will provide 40% heat rate for any heat call – regardless of the rate transmitted by the thermostat. This mode ends automatically after the first 60 minutes of operation after power-up.

100 PRCNT TEST – (SW2-2 = OFF and SW2-3 = ON) Represents the mode of operation which will provide 100% heat rate for any heat call – regardless of the rate transmitted by the thermostat. This mode ends automatically after the first 60 minutes of operation after power-up.

9. **AC HP STG MULT** – This allows for adjustment to the airflow for low-stage of cooling and heat-pump operation. See the section of this manual titled “DIPSWITCH” under “SW2” (SW2-4) for details and selections.

DUAL-FUEL OPERATION IN COMMUNICATING MODE

Systems configured for dual-fuel operation will include a communicating condenser with a reversing valve. Dual-fuel systems will display “*HP*” for Heat-Pump heat operation at the furnace control's (I.F.C.) dual seven-segment displays. During defrost mode, “*dF*” will be displayed. All other codes apply.

The balance point can be adjusted at the thermostat for optimal operation. The balance point is the point below which gas heat will be used and above which heat-pump heat will be used.

START-UP PROCEDURES

TO START THE FURNACE LIGHTING INSTRUCTIONS

This appliance is equipped with a hot surface ignition device. This device lights the main burners each time the room thermostat calls for heat. See the lighting instructions on the furnace.

During initial start-up, it is not unusual for odor or smoke to come out of any room registers. To ensure proper ventilation, it is recommended to open windows and doors, before initial firing.

The furnace has a negative pressure switch that is a safety during a call for heat. The induced draft blower must pull a negative pressure on the heat exchanger to close the negative pressure switch. The induced draft blower must maintain at least the negative pressure switch set point for the furnace to operate. If the induced draft blower fails to close or maintain the closing of the negative pressure switch, a “no heat call” would result.

1. Remove the burner compartment control access door.
2. **IMPORTANT:** Be sure that the manual gas control has been in the “OFF” position for at least five minutes. Do not attempt to manually light the main burners.
3. Set the room thermostat to its lowest setting and turn off the furnace electrical power.
4. Turn the gas control knob to the “ON” position.
5. Replace the burner compartment control access door.

▲ WARNING

FAILURE TO REPLACE THE BURNER DOOR CAN CAUSE PRODUCTS OF COMBUSTION TO BE RELEASED INTO THE CONDITIONED AREA RESULTING IN PERSONAL INJURY OR DEATH.

6. Turn on the manual gas stop.
7. Turn on the furnace electrical power.
8. Turn thermostat to “Heat” mode and set the room thermostat at least 10°F above room temperature to light the main burners.
9. After the burners are lit, set the room thermostat to a desired temperature.

FURNACE TEST MODE

See the section of this manual titled “DIPSWITCH” under “S4” for details about test mode.

TO SHUT DOWN THE FURNACE

1. Set the room thermostat to its lowest setting and turn to “OFF” position.
2. Turn off the manual gas stop and turn off the electrical power to the furnace.
3. Remove the burner compartment control access door.
4. Shut off the gas to the main burners by turning the gas control knob to the “OFF” position.
5. Replace the burner compartment control access door.

▲ WARNING

SHOULD OVERHEATING OCCUR OR THE GAS SUPPLY FAIL TO SHUT OFF, CLOSE THE MANUAL GAS VALVE FOR THE APPLIANCE BEFORE SHUTTING OFF THE ELECTRICAL SUPPLY. FAILURE TO DO SO CAN CAUSE AN EXPLOSION OR FIRE RESULTING IN PROPERTY DAMAGE, PERSONAL INJURY OR DEATH.

TABLE 20
NORMAL OPERATION CODES

NORMAL OPERATION CODES

Key

CODE	DISPLAYED TEXT
	DESCRIPTION

NORMAL OPERATION CODES

0	STANDBY MODE
	CODE AT DUAL 7-SEGMENT DISPLAY OF IFC: 0 DESCRIPTION: This code is displayed anytime there is no fault code to display and no thermostat call present. The furnace is idle.
H (steady)	GAS HEAT MODE
	CODE AT DUAL 7-SEGMENT DISPLAY OF IFC: H
C	LOW COOLING MODE
	CODE AT DUAL 7-SEGMENT DISPLAY OF IFC: C DESCRIPTION: Indicates low cooling for legacy systems only. This code is not used in communicating systems.
C	COOLING MODE
	CODE AT DUAL 7-SEGMENT DISPLAY OF IFC: C DESCRIPTION: This code indicates the furnace is in cooling mode (any stage) for communicating systems) high stage only for legacy systems.
HP	HEAT PUMP HEAT MODE
	CODE AT DUAL 7-SEGMENT DISPLAY OF IFC: HP or hP DESCRIPTION: This code indicates the furnace is in heat-pump heating mode (dual-fuel systems only) (any stage).
F	FAN MODE
	CODE AT DUAL 7-SEGMENT DISPLAY OF IFC: F DESCRIPTION: The furnace is in continuous fan mode.
dF	DEFROST MODE
	CODE AT DUAL 7-SEGMENT DISPLAY OF IFC: dF DESCRIPTION: This code indicates that the heat-pump is in deFrost mode (dual-fuel systems only) and furnace is operating as supplemental heat at a fixed 65% of maximum gas heating capacity.
Cd	DEHUMIDIFICATION MODE
	CODE AT DUAL 7-SEGMENT DISPLAY OF IFC: Cd DESCRIPTION: This code indicates that cooling is active with dehumidification active at the same time. When dehumidification is active, the cooling airflow will be reduced in order to allow water to accumulate on the condenser thereby removing humidity from the conditioned environment.

SEQUENCE OF OPERATION

Heating Cycle Initiation

The heating cycle is always initiated by a 24 volt signal on W of the thermostat or, for communicating systems, a message is transmitted from the thermostat to the IFC. When the controller senses 24 volts on W or the communicated message for heat call, the following sequence occurs:

- High and low pressure switches are checked to insure contacts are open.
- Inducer is powered on high speed for a thirty (30) second pre-purge.
- Pre-Purge:

There are two different types of pre-purge; a normal pre-purge and a learning-sequence pre-purge. During a learning-sequence pre-purge, the inducer motor will incrementally increase in RPM (stepping) until the low and high pressure switches are both closed. After both switches are sensed to be closed, the inducer motor will continue to run for an additional 30 seconds before the ignition trial.

A learning sequence pre-purge will be initiated under the following conditions:

- First heat call after power reset.
- Every 25th heat call.
- Next heat attempt after a failed pre-purge (pressure switch(es) does not close).
- Next heat attempt after a pressure switch has opened unexpectedly during normal heating operation.

A normal pre-purge will not go through the incremental stepping process of the inducer motor and should be much quicker. The inducer will start at a pre-determined RPM (determined during learning-sequence pre-purge) and this should close both pressure switches quickly. Once both pressure switches are sensed to be closed, the inducer will run for 30 seconds before the ignition trial starts.

- Hot - surface igniter is energized during the pre-purge period.
- The modulating gas valve is set to the highest possible rate (no flow yet).
- The main solenoids on the gas valve are energized allowing gas to flow to the burners.
- When flame is proven, the ignition control is de-energized - 8 second maximum trial time.
- The gas valve maintains 100% rate through the warm-up period - 20 seconds (aka Blower Off Delay).

Heating Cycle Response MODULATING FUNCTION:

("W" and "V" signal inputs, refer to dip switch set SW2 on IFC)

After the warm-up period, the furnace will respond to the thermostat demand by adjusting the gas valve pressure and blower speed anywhere between 40% to 100% heating capacity.

- **TWO-STAGE FUNCTION – NON-COMMUNICATING SYSTEMS ONLY:** (Two-stage function only applies when

TABLE 21
METER TIME

METER TIME IN MINUTES AND SECONDS FOR NORMAL INPUT RATING OF FURNACES EQUIPPED FOR NATURAL OR LP GAS											
INPUT BTU/HR	METER SIZE CU. FT.	HEATING VALUE OF GAS BTU PER CU. FT.									
		900		1000		1040		1100		2500 (LP)	
		MIN.	SEC.	MIN.	SEC.	MIN.	SEC.	MIN.	SEC.	MIN.	SEC.
60,000	ONE	0	54	1	0	1	3	1	6	2	30
	TEN	9	0	10	0	10	24	11	0	25	0
75,000	ONE	0	44	0	48	0	50	0	53	2	0
	TEN	7	12	8	0	8	19	8	48	20	0
90,000	ONE	0	36	0	40	0	42	0	44	1	40
	TEN	6	0	6	40	7	0	7	20	16	40
105,000	ONE	0	31	0	34	0	36	0	38	1	26
	TEN	5	10	5	40	6	0	6	20	14	20
120,000	ONE	0	27	0	30	0	31	0	33	1	15
	TEN	4	30	5	0	5	10	5	30	12	30

$$\text{Formula: Input BTU/HR} = \frac{\text{DRY Heating Value of Gas (BTU/FT}^3\text{) x 3600}}{\text{Time in Seconds (for 1 cu. ft.) of Gas}} \times C \cdot F$$

$$\text{Where } C \cdot F = \frac{\text{Gas Pressure (inch} \cdot \text{Hg) x 520 (}^\circ\text{F)}}{\text{Gas Temperature (}^\circ\text{F) x 30 (inches} \cdot \text{Hg)}}$$

both S4-2 and S4-3 are in the "ON" position and a two-stage thermostat is installed as shown in Figure 57.)

After the warm-up period, the furnace will respond to the thermostat demand by adjusting the gas valve pressure and blower heating speeds to the "W" signal values. "W" only = 40% gas valve pressure and blower heating speed. "W2" = 65% gas valve pressure and blower heating speed for first five minutes and 100% thereafter. Also, if the call for heat ends, the furnace terminates at the present rate.

- **SINGLE-STAGE FUNCTION – NON-COMMUNICATING SYSTEMS ONLY:** (SW2-2 and SW2-3 must both be turned "off" for this operation.)

("W" signal only)

After the warm-up period, the furnace will respond to the thermostat demand by altering the gas valve pressure and blower speed as follows:

Phase 1: 0 to 5 minutes = 40% of furnace capacity (gas valve output and blower speed)

Phase 2: 5 to 12 minutes = 65% of furnace capacity (gas valve output and blower speed)

Phase 3: After 12 minutes = 100% of furnace capacity (gas valve output and blower speed)

NOTE: If the call for heat ends during any phase, the furnace will terminate immediately at the firing rate of that phase.

Heating Cycle Termination

("W" signal only, refer to dip switch set SW2 on IFC)

When the 24 volt signal is removed from W1 or, for communicating systems, a message is transmitted from the thermostat to the furnace to "end the heat call", the heating cycle will end and the furnace will shut down and return to the proper off cycle operation.

SETTING INPUT RATE

Checking furnace input is important to prevent over firing beyond its design-rated input. NEVER SET INPUT ABOVE THAT SHOWN ON THE RATING PLATE. Use the following table or formula to determine input rate. Prior to checking the furnace input, make certain that all other gas appliances are shut off, with the exception of pilot burners. Time the meter with only the furnace in operation. Start the furnace, in Furnace Test Mode, 100% rate, and measure the time required to burn one cubic foot of gas.

The furnace is shipped from the factory with #50 orifices. They are sized for natural gas having a heating value of 1075 BTU/cu. ft. and a specific gravity of .60. For high-altitude models (option 278) the furnace comes equipped with #51 orifices installed for elevations 5,000 to 5,999 ft. These orifices may still need to be changed based on both elevation and gas heating value. Consult the section of this book titled "High Altitude Installation" for details.

Since heating values vary geographically, the manifold pressure and/or gas orifice size may need to be changed to adjust the furnace to its nameplate input. The rate will also vary with altitude. Consult the local gas utility to obtain the yearly average heating value and orifice size required to fire each individual burner at 15,000 BTUH. For high altitude installations, also consult the section of this manual titled "High Altitude Installations" for details on how to calculate the correct orifice size.

MAINTENANCE

⚠ WARNING

DISCONNECT MAIN ELECTRICAL POWER TO THE UNIT BEFORE ATTEMPTING ANY MAINTENANCE. FAILURE TO DO SO CAN CAUSE ELECTRICAL SHOCK RESULTING IN PERSONAL INJURY OR DEATH.

FILTERS

Keep the filters clean at all times. Remove the filter. Vacuum dirt from filter, wash with detergent and water, air dry thoroughly and reinstall.

NOTE: Some filters must be resized to fit certain units and applications. See Table 22 and Figures 47, 48 & 49.

1. 21" - 90,000 & 105,000 BTUH units require removal of a 3½-in. segment of filter and frame to get the proper width for a side filter.
2. 24½" - 120,000 BTUH unit requires removal of a 7" segment of filter and frame to get the proper width for a side filter.

**TABLE 22
FILTER SIZES**

UPFLOW FILTER SIZES				
FURNACE WIDTH	INPUT KBTUH	BOTTOM SIZE	SIDE SIZE	QUANTITY
17½"	60 AND 75	15¾" X 25"	15¾" X 25"	1
21"	90 AND 105	19¼" X 25"	15¾" X 25"	1
24½"	120	22¾" X 25"	15¾" X 25"	1

**FIGURE 48
RESIZING FILTERS AND FRAME**

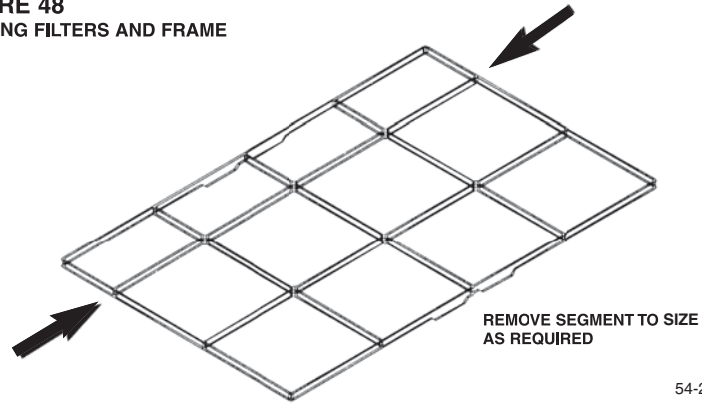

54-24094-01

**FIGURE 47
UPFLOW — FILTER REPLACEMENT**

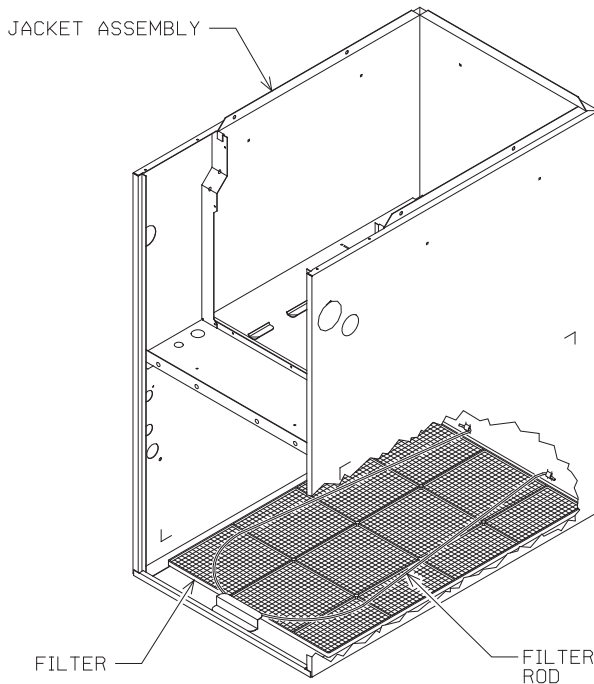

FILTER & ROD LOCATION

ADS-5422-01

FILTER MAINTENANCE

Instruct the user or homeowner on how to access the filters for regular maintenance.

Filter application and maintenance are critical to airflow, which may affect the heating and cooling system performance. Reduced airflow can shorten the life of the system's major components, such as motor, limits, heat exchanger, evaporator coil or compressor. Consequently, it is recommended that the return air duct system have only one filter location. The most common location will be inside the furnace or a filter base. Systems with a return-air filter grille or multiple filter grilles, can have a filter installed at each of the return-air openings. Installers are instructed to show the homeowner or end user where the filter has been installed.

If high efficiency filters or electronic air cleaners are used in the system, it is important that the airflow is not reduced in order to maximize system performance and life. Always verify that the system's airflow is not impaired by the filtering system that has been installed. This can be done by performing a temperature rise and temperature drop test.

Instruct the homeowner or end-user to keep the filter(s) clean at all times. Instruct them to vacuum dirt from the filter, wash with detergent and water, air dry thoroughly and reinstall.

The installer may install a return-air filter in place of the furnace filter.

DO NOT DOUBLE-FILTER THE RETURN-AIR DUCT SYSTEM. DO NOT FILTER THE SUPPLY AIR DUCT SYSTEM.

FIGURE 49
UPFLOW -- SIDE FILTER LOCATIONS

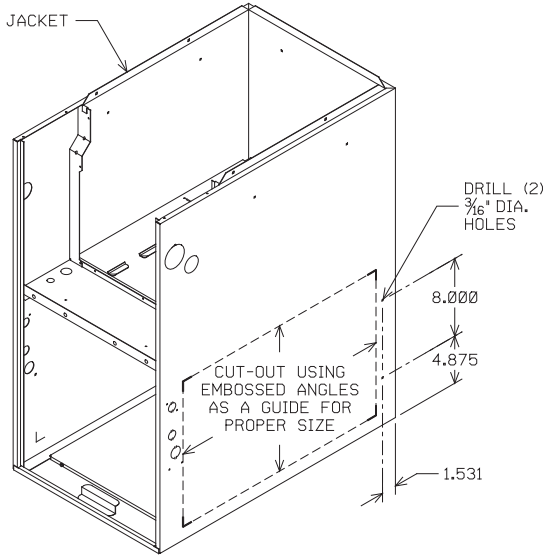

CUT-OUT AND DRILL DETAIL

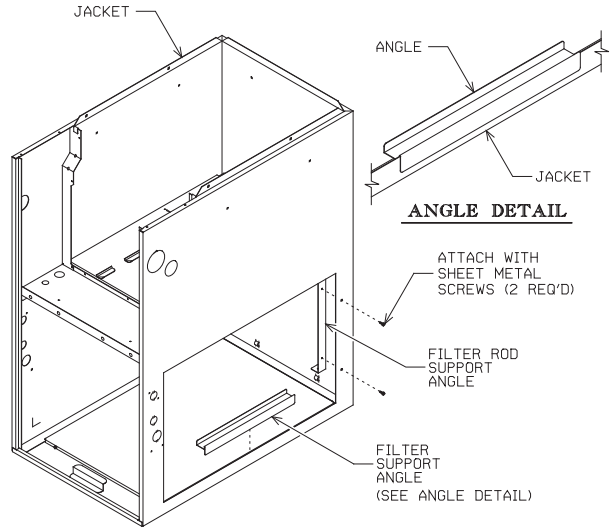

ROD & FILTER SUPPORT ANGLE ASSEMBLY

I332

▲ CAUTION

DO NOT OPERATE THE SYSTEM WITHOUT FILTERS. A PORTION OF THE DUST ENTRAINED IN THE AIR MAY TEMPORARILY LODGE IN THE AIR DUCT RUNS AND AT THE SUPPLY REGISTERS. ANY RECIRCULATED DUST PARTICLES WILL BE HEATED AND CHARRED BY CONTACT WITH THE FURNACE HEAT EXCHANGER. THIS RESIDUE WILL SOIL CEILINGS, WALLS, DRAPES, CARPETS AND OTHER HOUSEHOLD ARTICLES.

LUBRICATION

IMPORTANT: Do Not attempt to lubricate the bearings on the blower motor or the induced draft blower motor. Addition of lubricants can reduce the motor life and void the warranty.

The blower motor and induced draft blower motor bearings are prelubricated by the manufacturer and do not require further attention.

The blower motor and induced draft blower motor must be cleaned periodically by a qualified installer, service agency, or the gas supplier to prevent the possibility of overheating due to an accumulation of dust and dirt on the windings or on the motor exterior. The air filters should be kept clean. As dirty filters can restrict airflow. The motor depends upon sufficient air flowing across and through it to keep from overheating.

SYSTEM OPERATION INFORMATION

Advise The Customer

IMPORTANT: Replace all blower doors and compartment covers after servicing the furnace. Do not operate the unit without all panels and doors securely in place.

1. Keep the air filters clean. The heating system will operate more efficiently and more economically.
2. Arrange the furniture and drapes so that the supply air registers and the return air grilles are unobstructed.
3. Close doors and windows. This will reduce the heating load on the system.

4. Avoid excessive use of kitchen exhaust fans.
5. Do not permit the heat generated by television, lamps or radios to influence the thermostat operation.
6. Explain proper operation of the system with constant air circulation.

ANNUAL INSPECTION

The furnace should operate for many years without excessive scale build-up in the flue passageways. However, it is recommended that a qualified installer, service agency, or the gas supplier annually inspect the flue passageways, the vent system and the main burners for continued safe operation. Pay particular attention to deterioration from corrosion or other sources.

During the annual inspection, all electrical power to the furnace should be turned off and then restored. This will put the furnace into a calibration cycle on the initial call for heat. This is a five minute (or until the heat call is satisfied) cycle which allows the furnace to evaluate conditions. It should be noted, that a calibration cycle will occur on the initial call for heat each time after line voltage has been interrupted to the unit.

IMPORTANT: It is recommended that at the beginning and at approximately half way through the heating season, a visual inspection be made of the main burner flames for the desired flame appearance by a qualified installer, service agency or the gas supplier. If the flames are distorted and/or there is evidence of back pressure, check the vent and inlet air system for blockage. If there is carbon and scale in the heat exchanger tubes, the heat exchanger assembly should be replaced.

▲ WARNING

HOLES IN THE VENT PIPE OR HEAT EXCHANGER CAN CAUSE TOXIC FUMES TO ENTER THE HOME, RESULTING IN CARBON MONOXIDE POISONING OR DEATH. THE VENT PIPE OR HEAT EXCHANGER MUST BE REPLACED IF THEY LEAK.

IMPORTANT: It is recommended that at the beginning of the heating season, the flame sensor be cleaned with steel wool by a qualified installer, service agency or the gas supplier.

IMPORTANT: It is recommended that at the beginning of the heating season, the condensate trap be inspected for debris or blockage. A blocked condensate trap can cause water to back up into the primary heat exchanger and lead to nuisance tripping of the over temperature switches and/or pressure switches.

IMPORTANT: It is recommended that at the beginning of the heating season, the condensate neutralizer (if used) be replaced by a qualified installer, service agency or the gas supplier.

IMPORTANT: Drain traps will often dry out over a summer. During annual inspection the service person must verify that the trap still has water. If there is not enough water (or no water) in the trap, the service person must fill it to the appropriate level.

IMPORTANT: It is recommended that an annual inspection and cleaning of all furnace markings be made to assure legibility. Attach a replacement marking, which can be obtained through the distributor, if any are found to be illegible or missing.

REPLACEMENT PARTS

Contact your local distributor for a complete parts list.

TROUBLESHOOTING

Figure 50 is a troubleshooting flow-charts for the sequence of operation. Table 24 is for fault-code descriptions.

WIRING DIAGRAM

Figure 51 is a complete wiring diagram for the furnace and power sources.

FIGURE 50
TROUBLESHOOTING CHART

MODULATING INTEGRATED FURNACE CONTROL (IFC) TROUBLESHOOTING GUIDE

NOTE: Most failures are not due to the IFC or IDM controller. Double check all possibilities, including the ground connection, before replacing the IFC or IDM controller. Be sure note dip switch settings before troubleshooting. The inducer may go through a learning sequence during pre-purge, the correct troubleshooting procedure involves forcing the learning / calibration process.

The Calibration process will occur:

- 1) Any time after furnace power-up
- 2) Anytime a pressure switch is open unexpectedly during a heat call.
- 3) Every 25 successful heat cycles.

WARNING

HAZARDOUS VOLTAGE LINE VOLTAGE CONNECTIONS

DISCONNECT POWER BEFORE SERVICING. SERVICE MUST BE BY A TRAINED, QUALIFIED SERVICE TECHNICIAN.

KEY TO ABBREVIATIONS
 ECM = Constant CFM Blowers, (Electronically commutated motor)
 TSTAT = Thermostat.
 IDM = Induced Draft Motor (or Inducer),
 IFC = Integrated Furnace Control (or control board).
 PS = Pressure Switch(es),
 PFC = Power Factor Correction Choke,
 SE = Spark Electrode(s),
 SSD = Seven Segment Display of Furnace control
 COMM = Communication,
 I&O = Installation & Operation Instructions Manual.

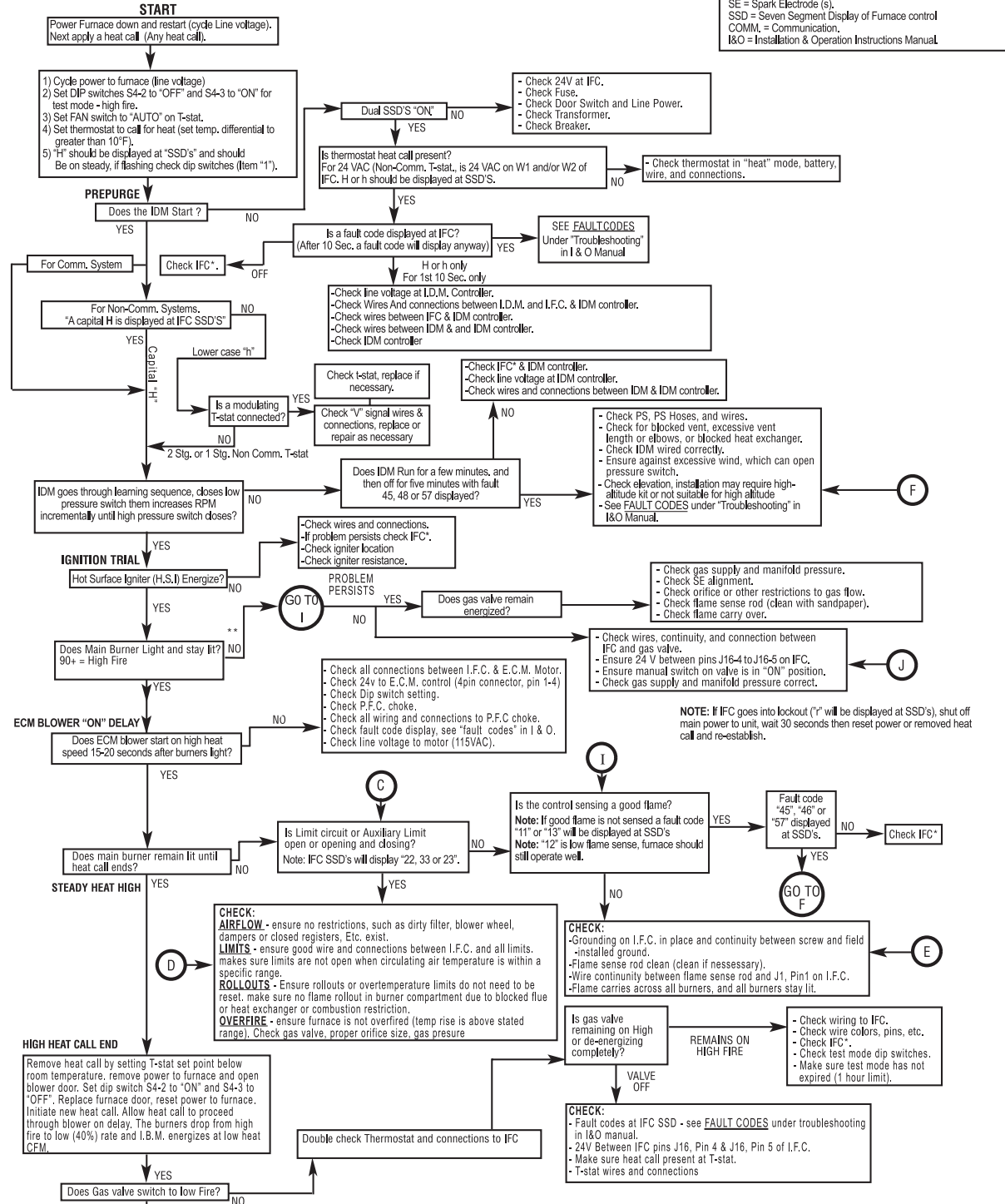
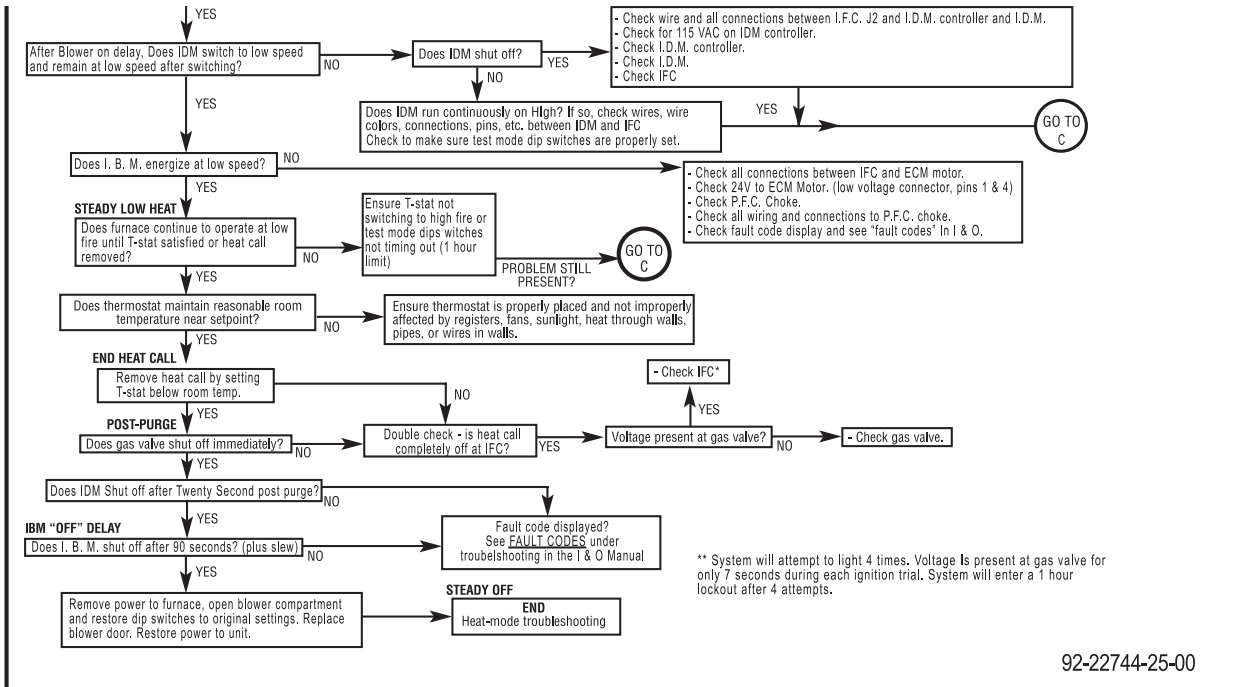

FIGURE 50 (CONTINUED)
TROUBLESHOOTING CHART – CONTINUED



92-22744-25-00

TABLE 23
NORMAL OPERATION CODES

NORMAL OPERATION CODES

Key

CODE	DISPLAYED TEXT
	DESCRIPTION

NORMAL OPERATION CODES

0	STANDBY MODE
	CODE AT DUAL 7-SEGMENT DISPLAY OF IFC: 0 DESCRIPTION: This code is displayed anytime there is no fault code to display and no thermostat call present. The furnace is idle.
H (steady)	GAS HEAT MODE
	CODE AT DUAL 7-SEGMENT DISPLAY OF IFC: H
C	LOW COOLING MODE
	CODE AT DUAL 7-SEGMENT DISPLAY OF IFC: C DESCRIPTION: Indicates low cooling for legacy systems only. This code is not used in communicating systems.
C	COOLING MODE
	CODE AT DUAL 7-SEGMENT DISPLAY OF IFC: C DESCRIPTION: This code indicates the furnace is in cooling mode (any stage) for communicating systems) high stage only for legacy systems.
HP	HEAT PUMP HEAT MODE
	CODE AT DUAL 7-SEGMENT DISPLAY OF IFC: HP or hP DESCRIPTION: This code indicates the furnace is in heat-pump heating mode (dual-fuel systems only) (any stage).
F	FAN MODE
	CODE AT DUAL 7-SEGMENT DISPLAY OF IFC: F DESCRIPTION: The furnace is in continuous fan mode.
dF	DEFROST MODE
	CODE AT DUAL 7-SEGMENT DISPLAY OF IFC: dF DESCRIPTION: This code indicates that the heat-pump is in deFrost mode (dual-fuel systems only) and furnace is operating as supplemental heat at a fixed 65% of maximum gas heating capacity.
Cd	DEHUMIDIFICATION MODE
	CODE AT DUAL 7-SEGMENT DISPLAY OF IFC: Cd DESCRIPTION: This code indicates that cooling is active with dehumidification active at the same time. When dehumidification is active, the cooling airflow will be reduced in order to allow water to accumulate on the condenser thereby removing humidity from the conditioned environment.

TABLE 24

FURNACE FAULT CODES EXPANDED W/DESCRIPTIONS AND SOLUTIONS

FAULT CODES

NOTE: The text in the "DISPLAYED TEXT" box shows combinations of upper-case and lower-case letters. Upper-case letters are used in the message displayed at the thermostat active fault screen. For example, the text **CARD-HARDWARE CoNFLICT** indicates that the message displayed at the thermostat active fault screen will be **CARD-HARD CNFLCT**.

NOTE: The following fault codes will not be stored back-to-back in the fault buffer. These will only be stored in the buffer if the previous fault stored was a different fault. 11, 45, 46 & 57.

Key

FAULT CODE	<u>DISPLAYED TEXT</u>
	<u>CODE AT DUAL 7-SEGMENT DISPLAY OF IFC & FAULT AREA OF COMM. THERMOSTAT</u>
	<u>MESSAGES TO HOMEOWNER AT COMM. THERMOSTAT</u>
	<u>MESSAGE IN FAULT AREA OF COMM. THERMOSTAT</u>
	<u>STATUS</u>
	<u>DESCRIPTION</u>
	<u>EXPECTED OPERATION</u>
	<u>CAUSE</u>
	<u>SOLUTION</u>

FAULT CODES

d1	<u>NO SHARED DATA</u>
	<u>CODE AT DUAL 7-SEGMENT DISPLAY OF IFC & FAULT AREA OF COMM. THERMOSTAT: d1</u>
	<u>MESSAGES TO HOMEOWNER AT COMM. THERMOSTAT: "CALL FOR SERVICE" & "CHECK FURNACE".</u>
	<u>MESSAGE IN FAULT AREA OF COMM. THERMOSTAT: "NO SHARED DATA "</u>
	<u>STATUS:</u> This is a critical fault. The furnace will not operate in any mode.
	<u>DESCRIPTION:</u> This code is displayed anytime there is no shared data at the furnace or (for communicating systems only) on the network (e.g. at the condenser or thermostat). The shared data is electronically stored data that is used to define (among other things) blower operation. Without the shared data, the furnace can not function. Note that shared data may be available even if there is no card attached to the furnace control. A missing memory card will display fault code "d4" if shared data is available on the network.
	<u>EXPECTED OPERATION:</u> No operation (including thermostat) will be permitted without the shared data. The shared data defines the IBM (Indoor Blower Motor) speed-torque curve. Without this information, the IBM can not operate. Refer to the section of this manual titled "INTEGRATED FURNACE CONTROL" under the subsection titled "MEMORY CARD" for details on the hierarchy of use of multiple copies of shared data and distribution (among other details) of shared data.
	<u>CAUSE:</u> Typically, the memory card will be missing from the furnace. In most cases, the cause of this fault will be the loss or disconnection of the original memory card from the furnace control (or I.F.C.). When the furnace control (or I.F.C.) is replaced, the memory card must be broken away, saved and installed in the replacement control. This is explained in detail in the section of this book titled <i>REPLACING THE FURNACE CONTROL</i> .
<u>SOLUTION:</u> Replace the missing memory card into the connector labeled J15 on the furnace control (I.F.C.). If the original card can not be found, a replacement card can be ordered from ProStock. Be sure to order the correct memory card for the furnace. Note: Furnace power must be cycled off and then on again after replacing the card or the shared data will not be read.	
d3	<u>AIRFLOW MISMATCH</u>
	<u>CODE AT DUAL 7-SEG DISPLAY OF HP/AC & FAULT AREA OF COMM. THERMOSTAT: d3</u>
	<u>MESSAGES TO HOMEOWNER AT COMMUNICATING THERMOSTATS: "CALL FOR SERVICE" & "CHECK FURNACE".</u>
	<u>MESSAGE IN FAULT AREA OF COMMUNICATING THERMOSTATS: AIRFLOW MISMATCH</u>
	<u>STATUS:</u> This is a critical fault. The air conditioner (or heat pump) condenser will not operate in communicating mode.
	<u>DESCRIPTION:</u> This message will not be displayed at the furnace. It will be displayed at the condenser but it involves the furnace. It is an indicator that the maximum airflow that can be supplied by the furnace is not enough capacity for the condenser.
	<u>EXPECTED OPERATION:</u> No cooling or heat-pump heating operation can take place. However, all other modes of operation (including gas heat) should proceed as normal. Refer to the section of this manual titled "INTEGRATED FURNACE CONTROL" under the subsection titled "MEMORY CARD" for details on the hierarchy of use of multiple copies of shared data and distribution (among other details) of shared data.
	<u>CAUSE:</u> The condenser selected is too large for the airflow capacity of the furnace.
<u>SOLUTION:</u> The condenser or furnace should be replaced with a condenser or furnace which will match the necessary airflow requirements of the condenser. Check specification sheets for both the furnace and the condenser to determine airflow capacity needed and supplied.	

(TABLE CONTINUES ON FOLLOWING PAGES)

TABLE 24 (CONTINUED)

FURNACE FAULT CODES EXPANDED W/DESCRIPTIONS AND SOLUTIONS – CONTINUED

d4	MEMory CARD INVALID
	CODE AT DUAL 7-SEGMENT DISPLAY OF IFC & FAULT AREA OF COMM. THERMOSTAT: <i>d4</i>
	MESSAGES TO HOMEOWNER AT COMMUNICATING THERMOSTATS: <i>(none)</i>
	MESSAGE IN FAULT AREA OF COMMUNICATING THERMOSTATS: "MEM CARD INVALID"
	STATUS: This is a non-critical fault. The furnace should operate in any mode.
	DESCRIPTION: The memory card inserted into the slot at position J15 of the furnace control is corrupt and can not be used <u>OR</u> there is no memory card installed at all. However, a valid copy of shared data for the furnace can be retrieved from the network.
	EXPECTED OPERATION: Shared data from the memory card can not be used because it is invalid. During the first (up to) five minutes of operation after power reset, the furnace may not respond to thermostat calls and/or fan calls (from either the thermostat or the condenser) while the furnace is searching the network for valid shared data. Until valid shared data is found, no operation will take place. Once valid network shared data has been found, operation should proceed as normal with this fault (d4) only being displayed during the standby mode. If no valid network shared data is found, the d4 fault will be replaced by a d1 fault (see d1) and no operation will take place until the issue is repaired.
	CAUSE: This fault is displayed when there is no information on the memory card (blank) or the memory card has corrupted and can not be properly read.
	SOLUTION: Remove the memory card and replace with the <i>original</i> memory card from the furnace or the <i>correct</i> replacement memory card. Never replace the memory card of a furnace with a memory card from another furnace or component (e.g. condenser or air handler). Doing so could result in improper operation of the blower which may cause damage to the heat exchanger. If the original memory card for the furnace control is available and working, it must be used. A correct replacement memory card can be ordered from ProStock. Be sure to have the furnace model and serial number available when ordering.
	CARD-HaRDware CoNFLiCT
CODE AT DUAL 7-SEGMENT DISPLAY OF IFC & FAULT AREA OF COMM. THERMOSTAT: <i>d5</i>	
MESSAGES TO HOMEOWNER AT COMMUNICATING THERMOSTATS: <i>(none)</i>	
MESSAGE IN FAULT AREA OF COMMUNICATING THERMOSTATS: "CARD-HRD CNFLCT"	
STATUS: This is a non-critical fault. The furnace should operate in any mode.	
DESCRIPTION: The memory card inserted into the slot at position J15 of the furnace control is not correct for the furnace application.	
EXPECTED OPERATION: Shared data from the memory card can not be used because it is invalid. During the first (up to) five minutes of operation after power reset, the furnace may not respond to thermostat calls and/or fan calls (from either the thermostat or the condenser) while the furnace is searching the network for valid shared data. Until valid shared data is found, no operation will take place. Once valid network shared data has been found, operation should proceed as normal with this fault (d5) only being displayed during the standby mode. If no valid network shared data is found, the d5 fault will be replaced by a d1 fault (see d1) and no operation will take place until the issue is repaired.	
CAUSE: There are a couple of reasons that this fault might be displayed: (1) The memory card inserted is from a different type of furnace (e.g.: from a two-stage furnace). (2) The memory card inserted is from an air handler or condenser or some other component.	
SOLUTION: Remove the memory card and replace with the <i>original</i> memory card from the furnace or the <i>correct</i> replacement memory card. Never replace the memory card of a furnace with a memory card from another furnace or component (e.g. condenser or air handler). Doing so could result in improper operation of the blower which may cause damage to the heat exchanger. If the original memory card for the furnace control is available and working, it must be used. A correct replacement memory card can be ordered from ProStock. Be sure to have the furnace model and serial number available when ordering.	

(TABLE CONTINUES ON FOLLOWING PAGES)

TABLE 24 (CONTINUED)

FURNACE FAULT CODES EXPANDED W/DESCRIPTIONS AND SOLUTIONS – CONTINUED

d6	<u>BLoWeR HorsePower CoNFLiCT</u>
	CODE AT DUAL 7-SEGMENT DISPLAY OF IFC & FAULT AREA OF COMM. THERMOSTAT: <i>d6</i>
	MESSAGES TO HOMEOWNER AT COMMUNICATING THERMOSTATS: (none)
	MESSAGE IN FAULT AREA OF COMMUNICATING THERMOSTATS: "BLWR HP CNFLCT"
	STATUS: This is a non-critical fault. The furnace should operate in any mode.
	DESCRIPTION: The horsepower reported by the motor does not match the horsepower stored in memory in the shared data of the memory card or furnace control.
	EXPECTED OPERATION: Shared data from the memory card can not be used because it is invalid. During the first (up to) five minutes of operation after power reset, the furnace may not respond to thermostat calls and/or fan calls (from either the thermostat or the condenser) while the furnace is searching the network for valid shared data. Until valid shared data is found, no operation will take place. Once valid network shared data has been found, operation should proceed as normal with this fault (d6) only being displayed during the standby mode. If no valid network shared data is found, the d6 fault will be replaced by a d1 fault (see d1) and no operation will take place until the issue is repaired.
	CAUSE: There are two possible causes for this fault: (1) The blower motor has recently been replaced and the wrong horsepower motor was used. (2) The memory card or furnace control has recently been replaced and the wrong card or replacement control was used.
	SOLUTION: Determine the correct motor and/or shared data card for the furnace and replace the incorrect part with a new, correct part. Never replace the memory card of a furnace with a memory card from another furnace or component (e.g. condenser or air handler). Doing so could result in improper operation of the blower which may cause damage to the heat exchanger. If the <i>original</i> memory card for the furnace control is available and working, it must be used. A correct replacement memory card can be ordered from ProStock. Be sure to have the furnace model and serial number available when ordering.
	d7
CODE AT DUAL 7-SEGMENT DISPLAY OF IFC & FAULT AREA OF COMM. THERMOSTAT: <i>d7</i>	
MESSAGES TO HOMEOWNER AT COMMUNICATING THERMOSTATS: (none)	
MESSAGE IN FAULT AREA OF COMMUNICATING THERMOSTATS: "BLWR MFR CNFLCT"	
STATUS: This is a non-critical fault. The furnace should operate in any mode.	
DESCRIPTION: This fault code is displayed any time the blower motor attached is able to communicate with the furnace control but is not recognized by the furnace control. If the motor attached is from a new manufacturer which was not supported at the time of production of the furnace control or memory card, the furnace control will not recognize the newer motor. For example, the motors available to be used in production at the time of this writing were Regal Beloit (RB) (formerly GE) and Emerson. If a Panasonic motor were added in the future, the Panasonic motor would not be recognized by the production control board and memory card made today. The d7 fault code would be displayed. Refer to the section of this manual titled "INTEGRATED FURNACE CONTROL" under the subsection titled "MEMORY CARD" for details on the hierarchy of use of multiple copies of shared data and distribution (among other details) of shared data.	
EXPECTED OPERATION: Shared data from the memory card can not be used because it is invalid. During the first (up to) five minutes of operation after power reset, the furnace may not respond to thermostat calls and/or fan calls (from either the thermostat or the condenser) while the furnace is searching the network for valid shared data. Until valid shared data is found, no operation will take place. Once valid network shared data has been found, operation should proceed as normal with this fault (d7) only being displayed during the standby mode. If no valid network shared data is found, the d7 fault will be replaced by a d1 fault (see d1) and no operation will take place until the issue is repaired.	
CAUSE: A motor manufactured by a non-supported OEM at the time of production of the furnace control and/or memory card is used to replace the blower motor.	
SOLUTION: Either (1) replace the blower motor with a supported motor or (2) replace the memory card and/or furnace control with a newer updated version that supports the newer motor. Never replace the memory card of a furnace with a memory card from another furnace or component (e.g. condenser or air handler). Doing so could result in improper operation of the blower which may cause damage to the heat exchanger.	

(TABLE CONTINUES ON FOLLOWING PAGES)

TABLE 24 (CONTINUED)

FURNACE FAULT CODES EXPANDED W/DESCRIPTIONS AND SOLUTIONS – CONTINUED

d8	OLD SHARED DATA
	CODE AT DUAL 7-SEGMENT DISPLAY OF IFC & FAULT AREA OF COMM. THERMOSTAT: <i>d8</i>
	MESSAGES TO HOMEOWNER AT COMMUNICATING THERMOSTATS: (none).
	MESSAGE IN FAULT AREA OF COMMUNICATING THERMOSTATS: "OLD SHARED DATA"
	STATUS: This is a non-critical fault. The furnace should operate in any mode.
	DESCRIPTION: This message is intended for future applications where the shared data of a newer furnace has been replaced with shared data from an older furnace. If, in the future, a new parameter is added to the shared data, an older memory card in this hypothetical furnace will force this fault to be displayed. If the new shared data parameter is critical to furnace operation, the furnace will use shared data from the network if available.
	EXPECTED OPERATION: Shared data from the memory card can not be used because it is invalid. During the first (up to) five minutes of operation after power reset, the furnace may not respond to thermostat calls and/or fan calls (from either the thermostat or the condenser) while the furnace is searching the network for valid shared data. Until valid shared data is found, no operation will take place. Once valid network shared data has been found, operation should proceed as normal with this fault (d8) only being displayed during the standby mode. If no valid network shared data is found, the d8 fault will be replaced by a d1 fault (see d1) and no operation will take place until the issue is repaired.
	CAUSE: The incorrect memory card has been used with the furnace control. Specifically, an older memory card has been used with a newer furnace and some operation (perhaps critical) can not be performed by the furnace.
	SOLUTION: Replace the older memory card with a newer card. If the original memory card for the furnace is available, it must be used. Never replace the memory card of a furnace with a memory card from another furnace or component (e.g. condenser or air handler). Doing so could result in improper operation of the blower which may cause damage to the heat exchanger. If the original memory card for the furnace control is available and working, it must be used. A correct replacement memory card can be ordered from ProStock. Be sure to have the furnace model and serial number available when ordering
	h
CODE AT DUAL 7-SEGMENT DISPLAY OF IFC: <i>h</i>	
MESSAGES TO HOMEOWNER AT COMMUNICATING THERMOSTATS: (Not Applicable)	
MESSAGE IN FAULT AREA OF COMMUNICATING THERMOSTATS: (Not Applicable)	
STATUS: This message is displayed only when using a 24 thermostat. It does not apply to fully communicating systems. The status is low-level and is not critical to furnace operation. However, the furnace's capacity to function in the best possible manner is slightly compromised. The code will only be displayed at the furnace control (or I.F.C.) dual seven-segment display. No information will be displayed at a communicating thermostat because this code does not apply to communicating systems.	
DESCRIPTION: When the lower-case "h" is displayed at the furnace control (or I.F.C.) dual seven-segment display, it indicates that the furnace is operating in heat mode and providing heat but the modulation function has been compromised. Two-stage or even three-stage operation is possible (through a timed algorithm) but full modulation will not be possible.	
EXPECTED OPERATION: Operation should proceed as normal with a perceivable difference in heating mode. This operation may either be single or two-stage staging operation as defined by the dials at SW2-2 and SW2-3 and may be as expected if neither a fully communicating thermostat nor non-communicating, fully modulating thermostat is used. However, this message will indicate a fault if a non-communicating, fully modulating thermostat is used and indicates that the "V" signal is not present as it should be. If this is the case, operation will be compromised and (most likely) only low-stage heat will be delivered. The thermostat may not satisfy properly and it will seem as if the furnace will not be able to deliver enough heat to "keep up".	
CAUSE: The modulating "V" signal can not be sensed by the furnace control. This may be OK if either a traditional single-stage or two-stage, non-communicating thermostat is used with a modulating furnace. If this is the case, the lower case "h" is normally displayed during heating operation and does not indicate abnormal operation. However, if a fully modulating, non-communicating thermostat is used and this message is displayed, it indicates the furnace control is not sensing the modulating "V" signal from the thermostat. A lower-case "h" should never be displayed during any operation with a fully communicating thermostat.	
SOLUTION: If a single-stage or two-stage, non-communicating thermostat is used, this operation is normal and no action needs to be taken. However, if the thermostat is fully modulating and non-communicating, the "V" signal is not being sensed by the furnace control (or I.F.C.) microprocessor. The connection (including wiring, wire nuts and etc.) should be checked first. If the connection is correct and OK, check the thermostat and then the furnace control (or I.F.C.).	

(TABLE CONTINUES ON FOLLOWING PAGES)

TABLE 24 (CONTINUED)

FURNACE FAULT CODES EXPANDED W/DESCRIPTIONS AND SOLUTIONS – CONTINUED

10	<u>IGNition 1 HouR ReTRY</u>
	CODE AT DUAL 7-SEGMENT DISPLAY OF IFC & FAULT AREA OF COMM. THERMOSTAT: 10
	MESSAGES TO HOMEOWNER AT COMMUNICATING THERMOSTATS: "CALL FOR SERVICE" & "CHECK FURNACE".
	MESSAGE IN FAULT AREA OF COMMUNICATING THERMOSTATS: "IGN 1 HR RTRY"
	STATUS: This is a critical fault. The furnace will not operate in gas heat modes but all other modes (e.g. cooling) should function.
	DESCRIPTION: This fault is displayed after four failed ignition attempts. After four attempts to ignite without success, the furnace control (or I.F.C.) goes into a lockout mode and will not attempt ignition again for one hour.
	EXPECTED OPERATION: After four failed ignition attempts (see fault code "11"), the furnace control (I.F.C.) will display "10" and will wait one hour before removing the "10" from the display and attempting the next ignition cycle provided the heat call is still present. If the first attempt at ignition after the one hour lockout is unsuccessful, the furnace control (I.F.C.) will attempt to light three more times before displaying "10" again and entering the second one-hour lockout. This cycle will repeat indefinitely until gas heat is established or the heat call has ended.
	CAUSE: There can be several causes for multiple failed ignition attempts. The most common are: (1) The flame sense rod is unable to sense flame. It may need cleaning or may not be properly connected. (2) The igniter is not working properly. It may not be properly connected or the spark location may not be correct. (3) The furnace control may not be working properly and may need to be replaced. (4) The flame may not be properly spreading from the first burner to the last.
SOLUTION: The solution will depend on the cause. Solutions to noted causes (1), (2), (3) and (4) above are: (1) Clean or replace the flame sense rod or check all connections and wire between the rod and the furnace control (or I.F.C.). (2) Replace or reposition the igniter or check all connections and wire between the igniter and the furnace control (or I.F.C.). (3) Replace the furnace control. (4) Check the manifold pressure during ignition. For natural gas it should be approx. 3.5" wc and for LP gas it should be 11" wc. If manifold pressure is good, watch the burner during ignition. If the first burner lights, but the second, third and so on do not light, the burner may need to be replaced.	

(TABLE CONTINUES ON FOLLOWING PAGES)

TABLE 24 (CONTINUED)

FURNACE FAULT CODES EXPANDED W/DESCRIPTIONS AND SOLUTIONS – CONTINUED

11	<u>FAILED IGNITION</u>
	CODE AT DUAL 7-SEGMENT DISPLAY OF IFC & FAULT AREA OF COMM. THERMOSTAT: 11
	MESSAGES TO HOMEOWNER AT COMMUNICATING THERMOSTATS: (none)
	MESSAGE IN FAULT AREA OF COMMUNICATING THERMOSTATS: "FAILED IGNITION"
	STATUS: Up to three failed ignitions will not constitute a critical condition. Critical condition (with no heating operation) is only noted when the furnace has failed to ignite four or more times in a row. After four failed ignition attempts, the fault code will change from "11" to "10" and will react as described under the description for fault code "10". Fault code "11" will not trigger a message to be displayed to the homeowner. It is only when the status is elevated to "10" that a message is displayed to the homeowner.
	DESCRIPTION: This fault is displayed at the furnace control after the first failed ignition attempt. It continues to be displayed until successful ignition or the furnace control has failed to ignite four consecutive times. After four attempts, the status of the fault is elevated to "10" and the furnace control (or I.F.C.) reacts as described under description for the fault code "10".
	Note: This fault will not be displayed to the homeowner on communicating systems unless it occurs at least three times within a single heat call. It will not be displayed to the homeowner after the first or even second failure. However, it will be displayed in the active fault screen of thermostat immediately after the first failure (and all subsequent failures) during a single heat call. Further, this fault (11) will only be logged into the fault buffer one time. It will not log more than once in the buffer.
	EXPECTED OPERATION: After the first failed ignition attempt, the fault ("11") is displayed and the inducer will complete a 20 second post-purge followed by a second ignition attempt. This cycle will be repeated until gas heat is established or until the fourth ignition attempt. After the fourth attempt, the furnace control (IFC) will proceed to one-hour lockout as described under the fault code "10".
	CAUSE: There can be several causes for a failed ignition attempt(s). The most common are: (1) The flame sense rod is unable to sense flame. It may need cleaning or may not be properly connected. (2) The gas valve may be turned off. (3) The igniter is not working properly. It may not be properly connected or the spark location may not be correct. (4) The furnace control may not be working properly and may need to be replaced. (5) The flame may not be properly spreading from the first burner to the last.
	SOLUTION: The solution will depend on the cause. Solutions to noted causes (1) through (5) above are: (1) Clean or replace the flame sense rod or check all connections and wire between the rod and the furnace control (or I.F.C.). Make sure furnace ground is properly connected. (2) Turn the valve on. (3) Replace or reposition the igniter or check all connections and wire between the igniter and the furnace control (or I.F.C.). (4) Replace the furnace control. (5) Check the manifold pressure during ignition. For natural gas it should be approx. 3.5" wc and for LP gas it should be 11" wc. If manifold pressure is good, watch the burner during ignition. If the first burner lights, but the second, third and so on do not light, the burner may need to be replaced.
12	<u>LOW FLAME SENSE</u>
	CODE AT DUAL 7-SEGMENT DISPLAY OF IFC & FAULT AREA OF COMM. THERMOSTAT: 12
	MESSAGES TO HOMEOWNER AT COMMUNICATING THERMOSTATS: (none)
	MESSAGE IN FAULT AREA OF COMMUNICATING THERMOSTATS: "LO FLAME SENSE"
	STATUS: The status of this fault is non-critical and furnace operation will continue as normal in heating (and all other) mode(s). If flame sense is low, the furnace control (or I.F.C.) may soon no longer be able to properly sense the flame and status of the problem may be elevated to the level of fault code "13" or fault "11" (if flame can not be sensed at all).
	DESCRIPTION: The flame sense current from the flame sense rod at the furnace control (or I.F.C.) is weak or marginal at best.
	EXPECTED OPERATION: All operation (including gas heat) will proceed as normal with only the fault code ("12") displayed at the furnace control (I.F.C.) and "LO FLAME SENSE" displayed in the fault area of a communicating thermostat.
	CAUSE: (1) The most common cause for low flame sense during heat operation is that the flame sense rod may need cleaning or may not be properly connected or wiring between the rod and the furnace control may be shorted or opened. (2) Another cause for low flame may be an improperly mounted or poorly grounded flame sensor. SOLUTION: (1) Clean or replace the flame sense rod or check all connections and wire between the rod and the furnace control (or I.F.C.). (2) Reinstall or replace flame sensor and check wiring and connections. Also make sure the furnace is properly grounded.

(TABLE CONTINUES ON FOLLOWING PAGES)

TABLE 24 (CONTINUED)

FURNACE FAULT CODES EXPANDED W/DESCRIPTIONS AND SOLUTIONS – CONTINUED

13	FLAME LOST
	CODE AT DUAL 7-SEGMENT DISPLAY OF IFC & FAULT AREA OF COMM. THERMOSTAT: 13
	MESSAGES TO HOMEOWNER AT COMMUNICATING THERMOSTATS: (none)
	MESSAGE IN FAULT AREA OF COMMUNICATING THERMOSTATS: "FLAME LOST"
	STATUS: Flame loss is not a critical fault. Subsequent ignition attempts will follow and normal operation should resume. However, a lost flame can often be followed by failed ignition attempts then a one-hour lockout. Once the status has reached one-hour lockout, the fault condition is critical (although attempts at ignition will be made again after the 1 hour lockout) and furnace operation will proceed as described under "10" ("IGN 1 HR RTRY").
	DESCRIPTION: After a successful ignition trial, the flame (which was properly sensed) is no longer sensed. This can happen any time after successful ignition while a valid heat call is present.
	EXPECTED OPERATION: When flame is lost, the fault code ("13") is immediately displayed at the IFC SSD's. The IBM (Indoor Blower Motor) is energized (if it was not already) at the correct speed (based on the demand from the thermostat) and completes a 90 second blower off delay. The IDM (Induced Draft Motor) remains energized at the most recent speed (based on the demand from the thermostat or as required for ignition cycle) for a 20 second post-purge. After both the post-purge and blower off delay are complete, the fault code ("13") is removed and a new attempt at ignition is made. Often, the new ignition attempt will fail and operation will proceed as though a failed ignition has occurred from that point (see fault code "11"). Note: This fault will not be displayed to the homeowner on communicating systems unless it occurs at least three times within a single heat call. It will not be displayed to the homeowner after the first or even second failure. However, it will be displayed in the active fault screen of thermostat immediately after the first failure (and all subsequent failures) during a single heat call. Further, this fault (13) will only be logged into the fault buffer one time. It will not log more than once in the buffer."
	CAUSE: (1) The most common cause for low flame sense during heat operation is that the flame sense rod may need cleaning or may not be properly connected or wiring between the rod and the furnace control may be shorted or opened. (2) Another cause for low flame may be an improperly mounted or poorly grounded flame sensor. (3) Flame pattern may be unstable.
	SOLUTION: (1) Clean or replace the flame sense rod or check all connections and wire between the rod and the furnace control (or I.F.C.). (2) Reinstall or replace flame sensor and check wiring and connections. Also make sure the furnace is properly grounded. (3) Check that all burner assembly components are properly installed. Check for good seals between the burner and blower compartments. Insure that the combustion door gasket is in place and the door is properly installed and sealed.
	16
CODE AT DUAL 7-SEGMENT DISPLAY OF IFC & FAULT AREA OF COMM. THERMOSTAT 16	
MESSAGES TO HOMEOWNER AT COMM. THERMOSTAT: "CALL FOR SERVICE" & "CHECK FURNACE".	
MESSAGE IN FAULT AREA OF COMM. THERMOSTAT: "IGN FAIL"	
STATUS: This is a critical fault. The furnace will not operate in any mode.	
DESCRIPTION: This code is displayed anytime there is an igniter failure. It may also be displayed if the furnace control relay for the igniter is not closing or cannot be sensed -indicating a faulty control board. The fault may also be displayed if there is improper grounding of the control board.	
EXPECTED OPERATION: Heating operation will not be permitted.	
CAUSE: The control cannot sense the igniter. The igniter may be out of spec, the control may be faulty or there may be a large potential difference between ground and neutral to the furnace control. SOLUTION: Check the igniter and the connections between the igniter and the control board. If these are OK, check ground potential between neutral and ground. There should be no more than 5 volts difference. If this is OK, check the furnace control. Replace if necessary.	

(TABLE CONTINUES ON FOLLOWING PAGES)

TABLE 24 (CONTINUED)

FURNACE FAULT CODES EXPANDED W/DESCRIPTIONS AND SOLUTIONS – CONTINUED

14	UNEXPECTED FLAME
	CODE AT DUAL 7-SEGMENT DISPLAY OF IFC & FAULT AREA OF COMM. THERMOSTAT: 14
	MESSAGES TO HOMEOWNER AT COMMUNICATING THERMOSTATS: "CALL FOR SERVICE" & "CHECK FURNACE".
	MESSAGE IN FAULT AREA OF COMMUNICATING THERMOSTATS: "UNEXPECTED FLAME"
	STATUS: This is an extremely critical fault and should rarely (if ever) be seen in the field. The furnace will not operate with this fault present.
	DESCRIPTION: This fault indicates flame is present when it should not be. Flame is seen to be present when the gas valve is supposed to be off.
	EXPECTED OPERATION: When unexpected flame is sensed, the IBM (Indoor Blower Motor) is energized at maximum heat speed and IDM (Induced Draft Motor) is energized at high speed. Both will remain energized until the fault is cleared. Response to any thermostat call is not permitted until the fault is cleared. Note that the gas valve circuit should not have been energized when the unexpected flame was sensed. When the fault is cleared, the IDM will complete a 20 second post-purge and the IBM will complete a 90 second blower off-delay.
	CAUSE: (1) Field mis-wiring of 24VAC to the gas valve main solenoid. (2) Faulty gas valve stuck in the "OPEN" position. (3) Faulty furnace control (signal improperly sensed when it should not be sensed at all).
	SOLUTION: (1) Wire properly. (2) Replace gas valve. (3) Replace furnace control.
	22
CODE AT DUAL 7-SEGMENT DISPLAY OF IFC & FAULT AREA OF COMM. THERMOSTAT: 22	
MESSAGES TO HOMEOWNER AT COMMUNICATING THERMOSTATS: "CALL FOR SERVICE" & "CHECK FURNACE".	
MESSAGE IN FAULT AREA OF COMMUNICATING THERMOSTATS: "MAIN LIMIT OPEN"	
STATUS: This is a critical fault. The furnace will not operate in gas heat modes but all other modes (e.g. cooling) should function.	
DESCRIPTION: The main limit has opened or is sensed to be opened. This normally means that the temperature inside the heat exchanger area has gone above a certain predetermined critical value and heating operation is not permitted until the limit cools to within normal parameters.	
EXPECTED OPERATION: When the main limit opens, the IBM (Indoor Blower Motor) will be energized at maximum heat speed. The gas valve circuit is de-energized (if it was energized) until the fault is cleared and the IDM (Induced Draft Motor) is energized at high speed and remains energized for 20 seconds after the fault is sensed. Response to thermostat cooling calls will take place as normal with IBM energizing at the higher of the two blower speeds (high heat or cool) when a call for cooling is also present. When the fault is cleared, the IBM will remain energized for the 90 second blower off-delay period.	
CAUSE: (1) No airflow (2) Insufficient airflow (3) Faulty limit control (4) Loose or faulty wiring. (5) Input too high	
SOLUTION: (1) Check for proper blower operation. Is the blower turning during heat (or any other) mode? If not, a blower motor fault should also be present. Check the wiring to the motor then check the motor. It may need replacing. (2) Check ductwork and filters. Determine the static pressure and make sure it is not above the published values for the furnace. Check the rate and outlet air temperature at high and low-fire heat (use the test mode dipswitches SW2-2 and SW2-3) and compare to the nameplate maximum values. Also, perform the calibration cycle again (if the SA sensor is installed) by cycling power to the furnace. (3) Replace the limit control. (4) Check wiring and connections. Replace and/or repair as necessary. (5) Insure properly sized burner orifices are installed. Check the manifold pressure at high fire and compare to the nameplate values. Adjust as needed.	

(TABLE CONTINUES ON FOLLOWING PAGES)

TABLE 24 (CONTINUED)

FURNACE FAULT CODES EXPANDED W/DESCRIPTIONS AND SOLUTIONS – CONTINUED

23	HALC (Heat Assisted Limit Control) LIMIT OPEN
	CODE AT DUAL 7-SEGMENT DISPLAY OF IFC & FAULT AREA OF COMM. THERMOSTAT: 23
	MESSAGES TO HOMEOWNER AT COMMUNICATING THERMOSTATS: "CALL FOR SERVICE" & "CHECK FURNACE".
	MESSAGE IN FAULT AREA OF COMMUNICATING THERMOSTATS: "HALC LIMIT OPEN"
	STATUS: This is a critical fault. The furnace will not operate in gas heat modes but all other modes (e.g. cooling) should function.
	DESCRIPTION: The Heat Assisted Limit Control (H.A.L.C.) has opened or is sensed to be opened. This normally means that the temperture inside the blower area has gone above a certain predetermined value and heating operation is not permitted until the limit cools to within normal parameters. For modulating furnaces, this limit is only present in downflow models. However, there is a jumper wire between the pins on the IFC (Integrated Furnace Control) of upflow modulating models. If the "23" fault code is displayed on upflow models, it generally means that the connection between the two pins (pins 5 and 11 of connector J1) has been compromised.
	EXPECTED OPERATION: When the HALC (Heat Assisted Limit Control) circuit has been opened, the IBM (Indoor Blower Motor) is energized at maximum heating speed. The gas valve circuit is de-energized (if it was energized) and the IDM (Induced Draft Motor) is energized at high speed for 20 seconds after the fault is sensed. Response to thermostat cooling calls will take place as normal with IBM energizing at the higher of the two blower speeds (high heat or cool) when a call for cooling is also present. When the fault is cleared, the IBM will remain energized for the 90 second blower off-delay period.
	<p>CAUSE:</p> <ul style="list-style-type: none"> (1) On upflow 90+ (modulating) furnaces, the jumper is loose, broken or missing. (2) On downflow 90+ (modulating) furnaces, the H.A.L.C. may be faulty. Check continuity. (3) Loose or faulty wiring. (4) On downflow 90+ (modulating) furnaces, the blower operation may be compromised. <p>SOLUTION:</p> <ul style="list-style-type: none"> (1) Repair the jumper between pins 5 and 11 of connector J1 on the furnace control. (2) Replace the limit control. (3) Check wiring and connections. Replace and/or repair as necessary. (4) Check for proper blower operation. Is the blower turning during heat (or any other) mode? If not, a blower motor fault should also be present. Check the wiring to the motor then check the motor. It may need replacing

(TABLE CONTINUES ON FOLLOWING PAGES)

TABLE 24 (CONTINUED)

FURNACE FAULT CODES EXPANDED W/DESCRIPTIONS AND SOLUTIONS – CONTINUED

26	LINE NeuTRaL ReVerSeD
	CODE AT DUAL 7-SEGMENT DISPLAY OF IFC & FAULT AREA OF COMM. THERMOSTAT: 26
	MESSAGES TO HOMEOWNER AT COMMUNICATING THERMOSTATS: "CALL FOR SERVICE" & "CHECK FURNACE".
	MESSAGE IN FAULT AREA OF COMMUNICATING THERMOSTATS: "LINE NTRL RVRSD"
	STATUS: This is a critical fault. The furnace will not operate in gas heat or any other modes.
	DESCRIPTION: This fault code is an indication that line voltage and neutral are reversed to the furnace control. No operation is not allowed to proceed until the problem is corrected.
	EXPECTED OPERATION: No heating or cooling operation will take place.
	CAUSE: (1) Line and neutral to the furnace have been interchanged at the furnace. (2) Line voltage and neutral have been interchanged at the disconnect or at the breaker box.
	SOLUTION: (1) Check voltage with meter and reverse line and neutral if necessary. (2) Check voltage with meter and reverse line and neutral if necessary.
	33
CODE AT DUAL 7-SEGMENT DISPLAY OF IFC & FAULT AREA OF COMM. THERMOSTAT: 33	
MESSAGES TO HOMEOWNER AT COMMUNICATING THERMOSTATS: "CALL FOR SERVICE" & "CHECK FURNACE".	
MESSAGE IN FAULT AREA OF COMMUNICATING THERMOSTATS: "MRLC OPEN"	
STATUS: This is a critical fault. The furnace will not operate in gas heat modes but all other modes (e.g. cooling) should function.	
DESCRIPTION: The Manually Reset Limit Control (M.R.L.C.) is also known by the name "Rollout Limit". There can be several on any given furnace. When one or more of these limits open, they must be manually pushed back to open (hence the name; <i>Manually</i> Reset) to force the acknowledgement of a critical fault. This fault will occur when flames have rolled out of the normal area in the heat exchanger and into the burner compartment. This fault should rarely (if ever) be seen in the field and indicates a very serious problem that must be fixed before furnace operation can continue.	
EXPECTED OPERATION: When the MRLC (Manually Reset Limit Control) circuit has been opened, the IBM (Indoor Blower Motor) is energized at maximum heating speed. The gas valve circuit is de-energized (if it was energized) and the IDM (Induced Draft Motor) is energized at high speed. Response to thermostat cooling calls will take place as normal with IBM energizing at the higher of the two blower speeds (high heat or cool) when a call for cooling is also present. When the fault is cleared, the IDM will remain energized for a 20 second post-purge and the IBM will remain energized for the 90 second blower off-delay period.	
CAUSE: (1) Insufficient venting through either the inlet or exhaust. (2) Loose or faulty wiring. (3) Unstable flame pattern.	
SOLUTION: (1) Check that the pressure switch(es) have not been welded closed or bypassed. Check that the inducer is operating at the proper rpm. Insure that the venting does not exceed the maximum specified lengths. Check for obstructions in combustion venting. Check that all gaskets between the inducer and center panel / heat exchanger are properly installed and sealed. (2) Check wiring and connections. Replace and/or repair as necessary. (3) Check that all burner assembly components are properly installed. Check that all seals between the burner and blower compartments are tight. Insure that the door seals are in place and that the burner door is properly installed and does not leak. Check to make sure that the heat exchanger has not been damaged; i.e.: crushed tubes, breached collector box and etc.	

(TABLE CONTINUES ON FOLLOWING PAGES)

TABLE 24 (CONTINUED)

FURNACE FAULT CODES EXPANDED W/DESCRIPTIONS AND SOLUTIONS – CONTINUED

44	LPC (Low Pressure Control (switch)) CLOSED
	CODE AT DUAL 7-SEGMENT DISPLAY OF IFC & FAULT AREA OF COMM. THERMOSTAT: 44
	MESSAGES TO HOMEOWNER AT COMMUNICATING THERMOSTATS: "CALL FOR SERVICE" & "CHECK FURNACE".
	MESSAGE IN FAULT AREA OF COMMUNICATING THERMOSTATS: "LPC CLOSED"
	STATUS: This is a critical fault. The furnace will not operate in gas heat modes but all other modes (e.g. cooling) should function if present simultaneously with a heating call (e.g. defrost call in dual-fuel mode).
	DESCRIPTION: The low pressure control (or switch) should not be closed when the inducer is not running. If it is, this is a sign of a serious condition. The switch may be welded closed or purposely bypassed in the field. Before any heat cycle can begin, the pressure switch is tested to make sure that it is opened. The switch is ignored except in gas heating modes.
	EXPECTED OPERATION: There will be no other operation than displaying of the fault code and diagnostic messages to the homeowner and technician. The fault code is only present during a heat call <i>before</i> pre-purge begins.
	CAUSE: (1) Faulty switch. (2) Pressure switch physically bypassed in the field. (3) Loose or faulty wiring. (4) Abnormally high negative pressure present on vent system without inducer running.
	SOLUTION: (1) Replace low pressure control (switch). (2) Remove bypass and restore correct operation. Determine reason for bypass (e.g. vent length too long) and correct issue. Notify homeowner and proper authorities of illegal tampering if necessary. (3) Check wiring and connections. Replace and/or repair as necessary. (4) Check for proper venting and terminations as defined in the furnace installation instructions.
	45
CODE AT DUAL 7-SEGMENT DISPLAY OF IFC & FAULT AREA OF COMM. THERMOSTAT: 45	
MESSAGES TO HOMEOWNER AT COMMUNICATING THERMOSTATS: "CALL FOR SERVICE" & "CHECK FURNACE".	
MESSAGE IN FAULT AREA OF COMMUNICATING THERMOSTATS: "LPC OPEN"	
STATUS: This is a critical fault. The furnace will not operate in gas heat modes but all other modes (e.g. cooling) should function if present simultaneously with a heating call (e.g. defrost call in dual-fuel mode).	
DESCRIPTION: This fault indicates that the low pressure switch is open when the inducer is energized at high speed. Since the modulating furnace only ignites at high fire, this condition should never be seen except after the blower on delay period of the ignition cycle and only after the furnace attempt to switch to a firing rate below 50%. The switch is ignored except in heating modes.	
EXPECTED OPERATION: This fault is displayed only after heat is established and switched to low fire with the IBM (Indoor Blower Motor) energized at low speed. When this fault is displayed the gas valve will be de-energized, the IBM will remain energized at the low heat speed and the IDM (Induced Draft Motor) will remain energized at the low speed. The IBM will complete a 90 second blower off-delay (at low speed) and the IDM will complete a 20 second post-purge (at low speed). After these delays, a new attempt at ignition will be made provided the call for heat is still present.	
CAUSE: (1) Blockage or improper termination in either the inlet or exhaust vents. (2) The flue vent length and/or number of elbows exceeds the maximum number specified. (3) Faulty or disconnected inducer. (4) Faulty control board (inducer relay). (5) High altitude kit not installed in areas of high elevation. (6) Loose or faulty wiring. (7) Disconnected, blocked, split or cut pressure switch hoses. (8) Wind gusts (sporadic). (9) Faulty pressure switch.	
SOLUTION: (1) Check the vent system for blockage and proper termination and repair as necessary. (2) Check the specification sheets and/or installation instructions. Remove excess venting. (3) Repair or replace inducer and/or inducer wiring and/or electrical connections. (4) Replace control board. (5) Check elevation of the installation and consult the specifications for the furnace to determine if a high altitude kit is needed. Install proper kit as necessary. (6) Check wiring and connections. Replace and/or repair as necessary. (7) Replace hoses as necessary. (8) Insure proper termination and determine if high altitude kit may be necessary (see item 4) (9) Replace the pressure switch.	

(TABLE CONTINUES ON FOLLOWING PAGES)

TABLE 24 (CONTINUED)

FURNACE FAULT CODES EXPANDED W/DESCRIPTIONS AND SOLUTIONS – CONTINUED

46	LPC (Low Pressure Control (switch)) OPEN
	CODE AT DUAL 7-SEGMENT DISPLAY OF IFC & FAULT AREA OF COMM. THERMOSTAT: 46
	MESSAGES TO HOMEOWNER AT COMMUNICATING THERMOSTATS: "CALL FOR SERVICE" & "CHECK FURNACE".
	MESSAGE IN FAULT AREA OF COMM. THERMOSTAT: "LPC OPEN"
	STATUS: This is a critical fault. The furnace will not operate in gas heat modes but all other modes (e.g. cooling) should function if present simultaneously with a heating call (e.g. defrost call in dual-fuel mode).
	DESCRIPTION: This fault indicates that the low pressure switch is open <i>when the inducer is energized at low speed</i> . The switch must close after the inducer is energized and before the ignition sequence can begin. The switch is ignored except in heating modes.
	EXPECTED OPERATION: (1) <u>DISPLAYED BEFORE HEAT IS ESTABLISHED:</u> The IBM (Indoor Blower Motor) will not be energized. The fault code will not be displayed until the IDM (Induced Draft Motor) has been energized for a minimum of ten seconds. The IDM will remain energized at the high speed (high speed is default pre-purge speed) for a period of five minutes after the beginning of the pre-purge attempt. After five minutes, the IDM is de-energized and second attempt at pre-purge is made (as long as the heat call is still present). This cycle is repeated indefinitely until either the pressure switch closes or the heat call is lost. (2) <u>DISPLAYED AFTER HEAT IS ESTABLISHED</u> - If this fault is displayed <i>after</i> heat is established, the gas valve will be de-energized, the IBM will be energized (if not already energized) at the correct heat speed (determined by the firing rate required by the thermostat) and the IDM will remain energized at high speed. The IBM will complete a 90 second blower off-delay and the IDM will complete a 20 second post-purge (at high speed). After these delays, a new attempt at ignition will be made provided the call for heat is still present.
	CAUSE: (1) Blockage or improper termination in either the inlet or exhaust vents. (2) The flue vent length and/or number of elbows exceeds the maximum number specified. (3) Faulty or disconnected inducer. (4) Faulty control board (inducer relay). (5) Loose or faulty wiring. (6) Disconnected, blocked, split or cut pressure switch hoses. (7) Wind gusts (sporadic). (8) Faulty pressure switch.
	SOLUTION: (1) Check the vent system for blockage and proper termination and repair as necessary. (2) Check the specification sheets and/or installation instructions. Remove excess venting. (3) Repair or replace inducer and/or inducer wiring and/or electrical connections. (4) Replace control board. (5) Check wiring and connections. Replace and/or repair as necessary. (6) Replace hoses as necessary. (7) Insure proper termination and determine if high altitude kit may be necessary (see item 4) (8) Replace the pressure switch.
	55
CODE AT DUAL 7-SEGMENT DISPLAY OF IFC & FAULT AREA OF COMM. THERMOSTAT: 55	
MESSAGES TO HOMEOWNER AT COMMUNICATING THERMOSTATS: "CALL FOR SERVICE" & "CHECK FURNACE".	
MESSAGE IN FAULT AREA OF COMMUNICATING THERMOSTATS: "HPC CLOSED"	
STATUS: This is a critical fault. The furnace will not operate in gas heat modes but all other modes (e.g. cooling) should function if present simultaneously with a heating call (e.g. defrost call in dual-fuel mode).	
DESCRIPTION: The high pressure control (or switch) should not be closed when the inducer is not running. If it is, this is a sign of a serious condition. The switch may be welded closed or purposely bypassed in the field. Before any heat cycle can begin, the pressure switch is tested to make sure that it is opened. The switch is ignored except in gas heating modes.	
EXPECTED OPERATION: There will be no other operation than displaying of the fault code and diagnostic messages to the homeowner and technician. The fault code is only present during a heat call before pre-purge begins.	
CAUSE: (1) Faulty switch. (2) Pressure switch physically bypassed in the field. (3) Loose or faulty wiring. (4) Abnormally high negative pressure present on vent system without inducer running.	
SOLUTION: (1) Replace high pressure control (switch). (2) Remove bypass and restore correct operation. Determine reason for bypass (e.g. vent length too long) and correct issue. Notify homeowner and proper authorities of illegal tampering if necessary. (3) Check wiring and connections. Replace and/or repair as necessary. (4) Check for proper venting and terminations as defined in the furnace installation instructions.	

(TABLE CONTINUES ON FOLLOWING PAGES)

TABLE 24 (CONTINUED)

FURNACE FAULT CODES EXPANDED W/DESCRIPTIONS AND SOLUTIONS – CONTINUED

57	HPC (High Pressure Control (switch)) OPEN
	CODE AT DUAL 7-SEGMENT DISPLAY OF IFC & FAULT AREA OF COMM. THERMOSTAT: 57
	MESSAGES TO HOMEOWNER AT COMMUNICATING THERMOSTATS: "CALL FOR SERVICE" & "CHECK FURNACE".
	MESSAGE IN FAULT AREA OF COMMUNICATING THERMOSTATS: "HPC OPEN"
	STATUS: This is a critical fault. The furnace will not operate in gas heat modes but all other modes (e.g. cooling) should function if present simultaneously with a heating call (e.g. defrost call in dual-fuel mode). If this fault is experienced during high heat operation (above 50% rate) and the low pressure switch remains engaged, the furnace will switch to low fire heat and continue to run (if possible) to try to satisfy the thermostat.
	DESCRIPTION: This fault indicates that the high pressure switch is open when the inducer is energized at high speed. This fault can be displayed any time during the heat call except during low heat call and only <i>after</i> the pre-purge and blower on delays are complete.
	EXPECTED OPERATION: (1) DISPLAYED BEFORE HEAT IS ESTABLISHED: The IBM (Indoor Blower Motor) will not be energized. The fault code will not be displayed until the IDM (Induced Draft Motor) has been energized for a minimum of ten seconds. The IDM will remain energized at the high speed (high speed is default pre-purge speed) for a period of five minutes after the beginning of the pre-purge attempt. After five minutes, the IDM is de-energized and second attempt at pre-purge is made (as long as the heat call is still present). This cycle is repeated indefinitely until either the pressure switch closes or the heat call is lost. (2) DISPLAYED AFTER HEAT IS ESTABLISHED - If this fault is displayed after heat is established, the IDM will remain energized at high speed and the firing rate will drop to low (40%) provided the low pressure switch remains closed. The IBM will energize at, or switch to, the low-fire rate (also provided the low pressure switch remains closed). Low heat is provided until the heat call ends or the high pressure switch closes. If the high pressure switch closes, the heat rate and blower speed will be adjusted to the correct (higher) rate required by the thermostat and the IDM will remain energized at high speed. If the low pressure switch also will not remain closed, operation will be as described under fault code # 46 ("LPC OPEN") above.
	CAUSE: (1) Blockage or improper termination in either the inlet or exhaust vents. (2) The flue vent length and/or number of elbows exceeds the maximum number specified. (3) Faulty or disconnected inducer. (4) Faulty control board (inducer relay). (5) High altitude kit not installed in areas of high elevation. (6) Loose or faulty wiring. (7) Disconnected, blocked, split or cut pressure switch hoses. (8) Wind gusts (sporadic). (9) Faulty pressure switch.
	SOLUTION: (1) Check the vent system for blockage and proper termination and repair as necessary. (2) Check the specification sheets and/or installation instructions. Remove excess venting. (3) Repair or replace inducer and/or inducer wiring and/or electrical connections. (4) Replace control board. (5) Check elevation of the installation and consult the specifications for the furnace to determine if a high altitude kit is needed. Install proper kit as necessary. (6) Check wiring and connections. Replace and/or repair as necessary. (7) Replace hoses as necessary. (8) Insure proper termination and determine if high altitude kit may be necessary (see item 4) (9) Replace the pressure switch.
	BLoWeR FauLT - RUNning
CODE AT DUAL 7-SEGMENT DISPLAY OF IFC & FAULT AREA OF COMM. THERMOSTAT: 60	
MESSAGES TO HOMEOWNER AT COMMUNICATING THERMOSTATS : (none)	
MESSAGE IN FAULT AREA OF COMMUNICATING THERMOSTATS: "BLWR FLT RUN"	
STATUS: This is a non-critical fault experienced by the furnace. All operations (including thermostat calls) should continue as normal with no perceivable difference in operation.	
DESCRIPTION: A blower fault which is non-critical allows the blower to continue to run but at less-than-optimal conditions.	
EXPECTED OPERATION: All (including thermostat) operation should continue as normal. Blower operation may be slightly compromised but will continue.	
CAUSE: (1) The blower has hit the maximum speed or torque limit specified by the manufacturer or is running at the temperature limit because the static pressure is too high.	
SOLUTION: (1) The static pressure is too high because the ductwork is improperly designed or is restricted for some other reason or the filter needs cleaning or replacing. Remove the obstruction or repair the duct so that static pressure does not exceed published values in the specification sheets or installation instructions.	

(TABLE CONTINUES ON FOLLOWING PAGES)

TABLE 24 (CONTINUED)

FURNACE FAULT CODES EXPANDED W/DESCRIPTIONS AND SOLUTIONS – CONTINUED

61	BLoWeR FauLT – Not RUNning
	CODE AT DUAL 7-SEGMENT DISPLAY OF IFC & FAULT AREA OF COMM. THERMOSTAT: 61
	MESSAGES TO HOMEOWNER AT COMMUNICATING THERMOSTATS: "CALL FOR SERVICE" & "CHECK FURNACE".
	MESSAGE IN FAULT AREA OF COMMUNICATING THERMOSTATS: "BLWR FLT NO RUN"
	STATUS: This is a critical fault. The furnace will not operate in any mode.
	DESCRIPTION: The blower has failed critically or there is a critical motor fault - such as thermal limit trip that prevents the blower motor from running.
	EXPECTED OPERATION: If the furnace was in heating operation when this fault occurred, blower operation will immediately stop and the furnace will shut down normally with post-purge at the correct speed. After the post purge (or immediately if no heat call was present), no other operation (including thermostat calls) will occur until this fault is cleared.
	CAUSE:
	(1) The motor has tripped on thermal limit because of a restriction or bearing failure. (2) The motor Power Factor Correction (P.F.C.) choke is faulty and needs replacing. (3) The furnace shared data is faulty or corrupted. (4) Wiring to the motor and/or P.F.C. has become compromised. (5) The motor has failed catastrophically.
	SOLUTION:
(1) Remove obstruction or replace motor. (2) Replace the Power Factor Correction choke. (3) Replace the furnace memory card with the correct replacement part from ProStock. (4) Inspect and replace or repair wiring and/or connectors to the motor and/or P.F.C. as necessary. (5) Replace the motor.	
66	BLoWeR OVERSPEED
	CODE AT DUAL 7-SEGMENT DISPLAY OF IFC & FAULT AREA OF COMM. THERMOSTAT: 66
	MESSAGES TO HOMEOWNER AT COMMUNICATING THERMOSTATS: (none)
	MESSAGE IN FAULT AREA OF COMMUNICATING THERMOSTATS: "BLWR OVERSPEED"
	STATUS: This is a non-critical fault experienced by the furnace. All operations (including thermostat calls) should continue as normal with no perceivable difference in operation.
	DESCRIPTION: The blower motor is operating at the highest rpm or torque that specifications allow but the application requires more torque or speed in order to get the desired airflow under the current static pressure conditions. The motor will continue to operate because internal software will prevent operation above the permitted range. However, a fault is sent to the furnace control (or I.F.C.) from the motor. Note: This fault will not be displayed after the first hour of blower operation after power reset. Further, this fault will not be logged in the fault buffer or fault history after the first hour of operation and will only be logged into the fault buffer a maximum of one time. Thiscode (66) indication is intended as a tool to notify the installer of inadequate airflow due to excessive static pressure in the duct of the system. The code is not intended to be a fault code. It is merely an operating indicator.
	EXPECTED OPERATION: All (including thermostat) operation should continue as normal. Blower operation may be slightly compromised but will continue.
	CAUSE:
	(1) The blower has hit the maximum speed or torque limit specified by the manufacturer because the static pressure is too high.
	SOLUTION:
(1) The static pressure is too high because the ductwork is improperly designed or is restricted for some other reason or the filter needs cleaning or replacing. Remove the obstruction or repair the duct so that static pressure does not exceed published values in the specification sheets or installation instructions for the furnace.	

(TABLE CONTINUES ON FOLLOWING PAGES)

TABLE 24 (CONTINUED)

FURNACE FAULT CODES EXPANDED W/DESCRIPTIONS AND SOLUTIONS – CONTINUED

68	<u>NO BLoWeR COMMunications</u>
	CODE AT DUAL 7-SEGMENT DISPLAY OF IFC & FAULT AREA OF COMM. THERMOSTAT: 68
	MESSAGES TO HOMEOWNER AT COMMUNICATING THERMOSTATS: "CALL FOR SERVICE" & "CHECK FURNACE".
	MESSAGE IN FAULT AREA OF COMMUNICATING THERMOSTATS: "NO BLWR COMM"
	STATUS: This is a critical fault. The furnace will not operate in any mode.
	DESCRIPTION: The furnace control (I.F.C.) can not communicate with the blower motor.
	EXPECTED OPERATION: If the furnace was in heating operation when this fault occurred, the gas valve will immediately close (flame will be lost), IBM (Indoor Blower Motor) operation will immediately stop and the furnace will shut down normally (except without IBM operation) with IDM (Induced Draft Motor) post-purge at the correct speed. After the post purge (or immediately if no heat call was present), no other operation (including thermostat calls) will occur until this fault is cleared.
	CAUSE: (1) The wires between the blower motor have been disconnected or there is a poor connection. (2) There is no line voltage to the motor. (3) The furnace shared data is faulty or corrupted. (4) The motor has failed catastrophically.
	SOLUTION: (1) Check wiring, connectors and terminals - repair or replace as necessary. (2) Check line voltage wiring, connectors and terminals to the Power Factor Correction choke and ECM motor. Repair and replace as necessary. (3) Replace the furnace memory card with the correct replacement part from ProStock. (4) Replace the motor.
	71
CODE AT DUAL 7-SEGMENT DISPLAY OF IFC: 71	
MESSAGES TO HOMEOWNER AT COMMUNICATING THERMOSTATS: "CALL FOR SERVICE" & "CHECK FURNACE".	
MESSAGE IN FAULT AREA OF COMMUNICATING THERMOSTATS: "NO INDUCER COMM"	
STATUS: This is a critical fault. The furnace will not operate in gas heat modes but all other modes (e.g. cooling) should function.	
DESCRIPTION: When attempting to communicate with the inducer controller module (electronic control board in blower compartment), communications can not be established or response from the inducer controller module is not as expected.	
EXPECTED OPERATION: Upon fault declaration, if currently in steady-state heating mode, the gas valve will be immediately de-energized. Commands to operate the inducer at post purge will attempt to be sent but will likely not be received because the communications link has been interrupted. The Air Circulating Blower (A.C.B.) will complete the 90 second blower off delay. Further heating operation will not take place until communications with the inducer controller can be established again. This fault will not affect the furnace during any other operation except heating.	
CAUSE: The cause can be interrupted wiring between the main furnace control and the inducer controller module or interrupted wiring between the inducer controller module and the inducer itself. Other causes can be a defective inducer controller module or a defective inducer.	
SOLUTION: Check the wiring between the furnace controller (I.F.C.) and the inducer controller module. Check wiring between the inducer controller module and the inducer. Check line voltage to the inducer controller module. If these are ok, replace the inducer controller module and/or inducer.	

(TABLE CONTINUES ON FOLLOWING PAGE)

TABLE 24 (CONTINUED)

FURNACE FAULT CODES EXPANDED W/DESCRIPTIONS AND SOLUTIONS – CONTINUED

77	<u>NO Gas Valve FEEDBACK</u>
	CODE AT DUAL 7-SEGMENT DISPLAY OF IFC & FAULT AREA OF COMM. THERMOSTAT: 77
	MESSAGES TO HOMEOWNER AT COMMUNICATING THERMOSTATS: "CALL FOR SERVICE" & "CHECK FURNACE".
	MESSAGE IN FAULT AREA OF COMMUNICATING THERMOSTATS: "NO GV FEEDBACK"
	STATUS: This is a critical fault. The furnace will not operate in gas heat modes but all other modes (e.g. cooling) should function.
	DESCRIPTION: The furnace control has lost communications with the gas valve.
	EXPECTED OPERATION: If the furnace was in heating operation when this fault occurred, the gas valve will immediately close (flame will be lost), IBM (Indoor Blower Motor) operation will immediately stop and the furnace will shut down normally (except without IBM operation) with IDM (Induced Draft Motor) post-purge at the correct speed. After the post purge (or immediately if no heat call was present), no other operation (including thermostat calls) will occur until this fault is cleared.
	CAUSE: (1) The wires, connectors or terminals between the furnace control (or I.F.C.) have become disconnected or there is a poor connection. (2) The gas valve is faulty. (3) The furnace control is faulty.
	SOLUTION: (1) Check the wires, connectors or terminals between the gas valve and furnace control (or I.F.C.). Replace or repair as necessary. (2) Replace the gas valve. (3) Replace the furnace control.
	93
CODE AT DUAL 7-SEGMENT DISPLAY OF IFC & FAULT AREA OF COMM. THERMOSTAT: 93	
MESSAGES TO HOMEOWNER AT COMMUNICATING THERMOSTATS: "CALL FOR SERVICE" & "CHECK FURNACE".	
MESSAGE IN FAULT AREA OF COMMUNICATING THERMOSTATS: "CONTROL FLT"	
STATUS: This is a critical fault. The furnace will not operate in any mode of operation.	
DESCRIPTION: This is a severe fault that should rarely (if ever) be discovered in the field. It is an indicator of an internal microprocessor fault on the furnace control (or I.F.C.) or voltage applied to the main gas valve solenoid when there should be none.	
EXPECTED OPERATION: If possible, if the furnace was in heating operation when this fault occurred, the gas valve will immediately close (flame will be lost), IBM (Indoor Blower Motor) operation will immediately stop and the furnace will shut down normally (except without IBM operation) with IDM (Induced Draft Motor) post-purge at the correct speed. After the post purge (or immediately if no heat call was present), no other operation (including thermostat calls) will occur until this fault is cleared. However, this fault may also indicate an internal microprocessor failure. This may mean that the heat call will not end as expected and that all outputs will be de-energized and gas valve closed immediately when the fault is sensed.	
CAUSE: (1) 24VAC or similar voltage applied to the main gas valve solenoid circuit unexpectedly. (2) Furnace control software test failure - failed furnace control (or I.F.C.).	
SOLUTION: (1) Check for miswiring in the furnace. (2) Replace the furnace control (or I.F.C.).	

FIGURE 51

WIRING DIAGRAM – STEPPER MODULATING GAS VALVE (FUEL CODE HU) (FURNACE MODEL IS RGFE & RGGE)

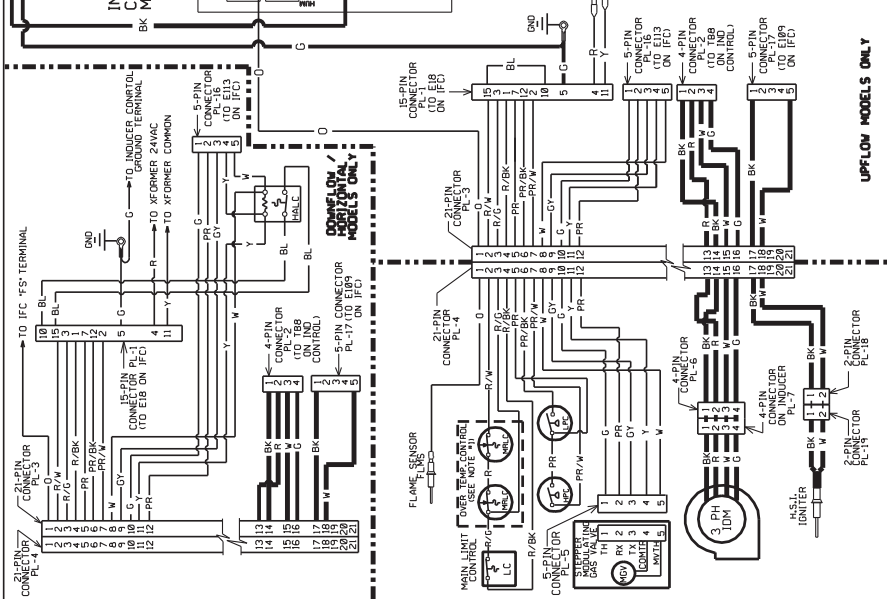
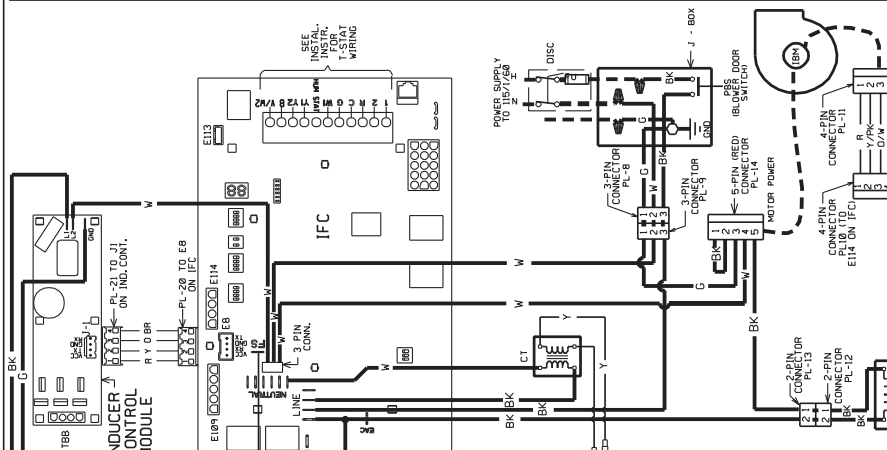
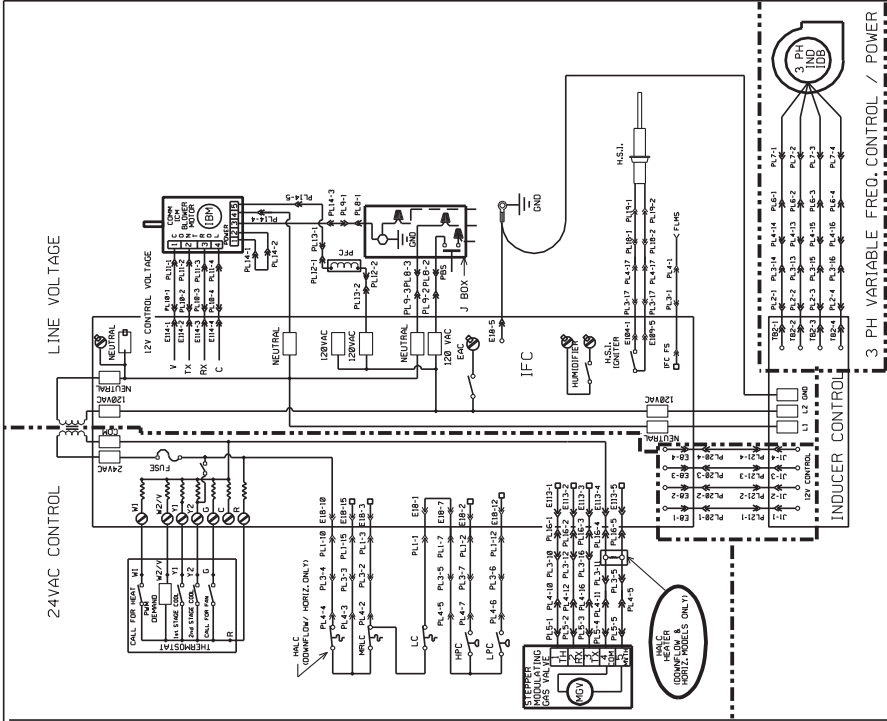

WIRE COLOR CODE

BK	BLACK	GY	GRAY	R	RED
BR	BROWN	O	ORANGE	W	WHITE
BL	BLUE	PK	PINK	Y	YELLOW
G	GREEN	PR	PURPLE		

ELECTRICAL WIRING DIAGRAM
 UPFLOW / DOWNFLOW - HORIZONTAL
 BLOWER INDUCED DRAFTING
 NO PLUS GAS TYPE FORCED
 90 PLUS AIR FURNACE
 WHITE-RODGERS SOLENOID CONTROL
 HOT SURFACE IGNITION

DR. BY JIM DATE 6-21-10 DWG. NO. 90-24216-07 REV 02

WIRING INFORMATION

LINE VOLTAGE

- FACTORY STANDARD
- FACTORY OPTION
- FIELD INSTALLED

LOW VOLTAGE

- FACTORY STANDARD
- FACTORY OPTION
- FIELD INSTALLED

REPLACEMENT WIRE

- MUST BE THE SAME SIZE AND TYPE OF INSULATION AS ORIGINAL (105 C MIN.)
- CABINET MUST BE PERMANENTLY GROUNDED AND CONFORM TO I.E.C., N.E.C., C.E.C. AND LOCAL CODES AS APPLICABLE.

- NOTES:**
1. 0FG-06 MODEL REQUIRES (1) MRLC & 0FG-12 REQUIRES (3) MRLC'S. ALL OTHER MODELS REQUIRE (2).
 2. BREAK AWAY MEMORY CARD AND RESET WITH FURNACE WHEN REPLACING IFC.

COMPONENT CODE

LPC	LOW PRESSURE CONTROL
M	MAIN MEMORY CARD
MCV	MEMORY CARD
MV	MAN VOLTAGE
MRLC	MAN RESET LIMIT CONTROL
PBS	PUSH BUTTON SWITCH
PFC	POWER FACTOR CHOKE
PL	PLUG CAPACITOR
SC	SUN SENSOR
SL	SOLENOID
TM	THERMISTOR
W	WIRE NUT

- COMMON
- CONTROL TRANSFORMER
- DISCONNECT SWITCH
- FLAME SENSOR
- FUSE
- GROUND
- HVDC
- HEAT ASSISTED LIMIT CONTROL
- HPC
- HIGH PRESSURE CONTROL
- INDUCER BLOWER MOTOR
- INDUCED DRAFT MOTOR
- INTEGRATED FURNACE CONTROL
- LIMIT CONTROL

THERMOSTATS

NON-COMMUNICATING THERMOSTATS

THERMOSTAT WIRING

NOTE: For fully modulating function with a non-communicating thermostat, the furnace must be installed with the (-)HC-TST412MDMS Modulating Touch-Screen Thermostat.

NOTE: Do not use 24 volt control wire smaller than No. 18 AWG.

Wire all non-communicating thermostats to the 24V connections on the integrated furnace control. See Figures 53 through 58.

NOTE: A larger wire gage may be required for longer lengths of thermostat wire.

For proper installation of the Variable Output Thermostat, follow the “Thermostat Installation, Programming and Troubleshooting Manual” included as section II of this manual. For proper installation of a Single-Stage or Two-Stage Thermostat, see the Installation Instructions included with the thermostat.

► FURNACE OPERATION USING MODULATING, SINGLE-STAGE, AND TWO-STAGE THERMOSTATS

The modulating furnace with the UT Electronic Controls IFC is also capable of operating with a traditional single-stage or a two-stage non-communicating thermostat as well as the modulating (both communicating and non-communicating) thermostat. The control will operate with either single-stage or two-stage non-communicating thermostats as a modulating system using an algorithm that utilizes three distinct firing rates; 40%, 65% and 100% of the furnace heating capacity (See below for operation of each).

Figures 53 through 58 detail how to wire the modulating furnace for operation with non-communicating modulating thermostat, single-stage thermostat, or two-stage thermostat.

► FURNACE OPERATION WITH A MODULATING THERMOSTAT

As described previously in this manual, operation with a non-communicating modulating or communicating thermostat when installed as shown in Figures 54 and 55 are fully modulating between 40% and 100% of furnace capacity. The firing rate is first determined by the thermostat and then sent to the furnace. This is the optimum mode of operation and will give the

FIGURE 52
24-VOLT TERMINALS

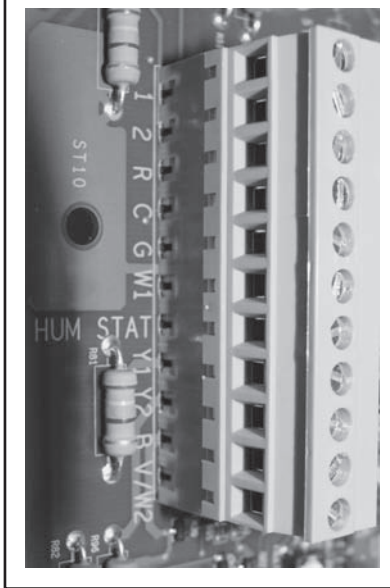

best temperature control with minimal temperature variation from the desired set point.

▲ WARNING

WHEN A NON-COMMUNICATING (24V) MODULATING THERMOSTAT IS INSTALLED, DO NOT APPLY 24VAC TO V/W2 AT THE FURNACE CONTROL (THIS IS SOMETIMES DONE DURING SETUP, TROUBLESHOOTING AND/OR WHILE DIAGNOSING PROBLEMS). DOING SO WILL DAMAGE THE THERMOSTAT.

► FURNACE OPERATION WITH A SINGLE STAGE NON-COMMUNICATING THERMOSTAT

To operate the furnace with a single-stage non-communicating thermostat, set switches 2 & 3 of S4 (See Figure 41) to the “OFF” position. Note that these switches should be in the “OFF” position from the factory. The lack of the modulating “V” signal will automatically be sensed as a single-stage thermostat and the furnace will operate accordingly.

With a single-stage non-communicating thermostat (installed as shown in Figure 56), during a call for heat, the furnace will operate as follows:

Phase 1: 0 to 5 minutes = 40% of furnace capacity

Phase 2: 5 to 12 minutes = 65% of furnace capacity

Phase 3: After 12 minutes = 100 % of furnace capacity

NOTE: If the call for heat ends during any phase, the furnace will terminate immediately at the firing rate of that phase.

If switches 2 & 3 of S4 are in the “ON” position, the furnace will always operate at 40% with a single-stage non-communicating thermostat installed as shown in Figure 57.

THIS CONFIGURATION IS NEITHER RECOMMENDED NOR APPROVED.

FIGURE 53
WIRING DIAGRAM FOR MODULATING HEAT (NO DUAL FUEL) (NON-COMMUNICATING)

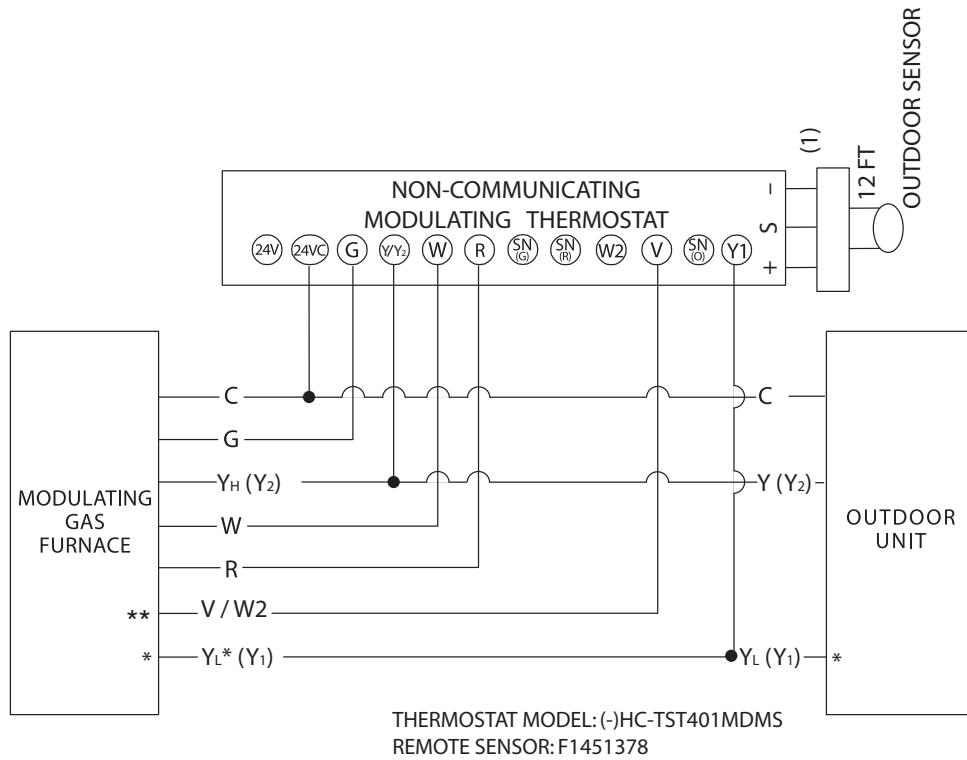

*2 STAGE COOLING ONLY

(1) FOR REMOTE SENSOR INSTALLATION
 SEE THERMOSTAT INSTALLATION INSTRUCTIONS

****WARNING: DO NOT APPLY 24VAC TO THE V/W2 TERMINAL ON THE IFC (THIS IS OFTEN DONE DURING SETUP, TROUBLESHOOTING AND/OR DIAGNOSING PROBLEMS). DOING SO WILL DAMAGE THE THERMOSTAT.**

FIGURE 54
FULLY MODULATING – TYPICAL DUAL FUEL APPLICATION – SINGLE STAGE HEAT PUMP (NON-COMMUNICATING)

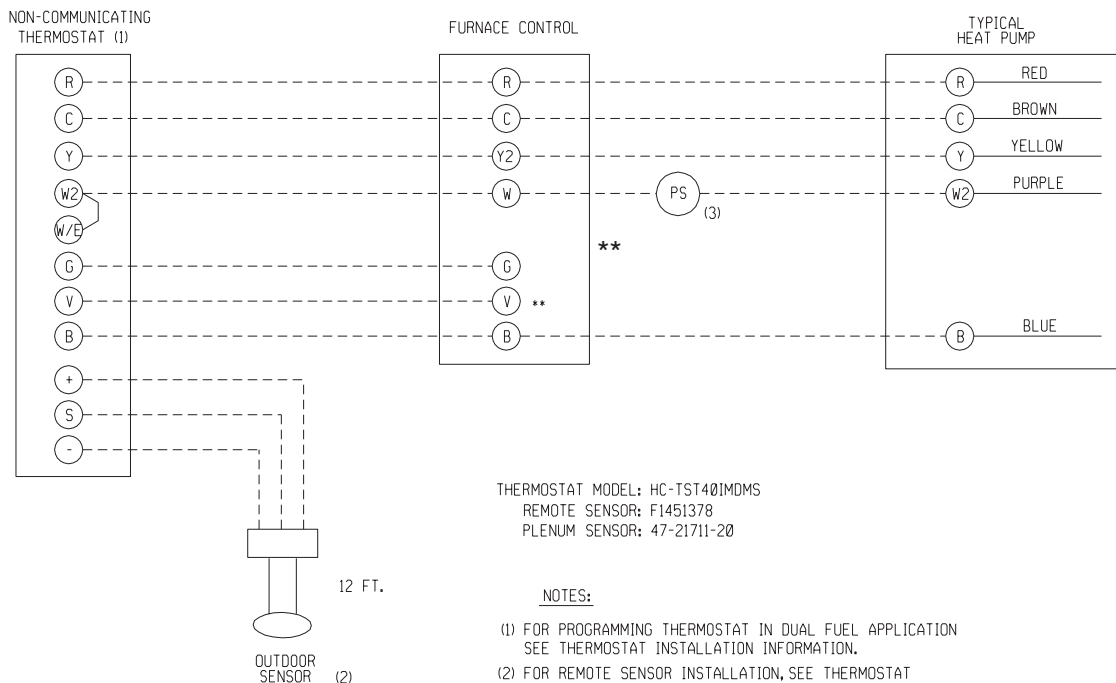

ST-A1168-01

****WARNING: DO NOT APPLY 24VAC TO THE V/W2 TERMINAL ON THE IFC (THIS IS OFTEN DONE DURING SETUP, TROUBLESHOOTING AND/OR DIAGNOSING PROBLEMS). DOING SO WILL DAMAGE THE THERMOSTAT.**

FIGURE 55
FULLY MODULATING – TYPICAL DUAL FUEL APPLICATION - TWO STAGE HEAT PUMP (NON-COMMUNICATING)

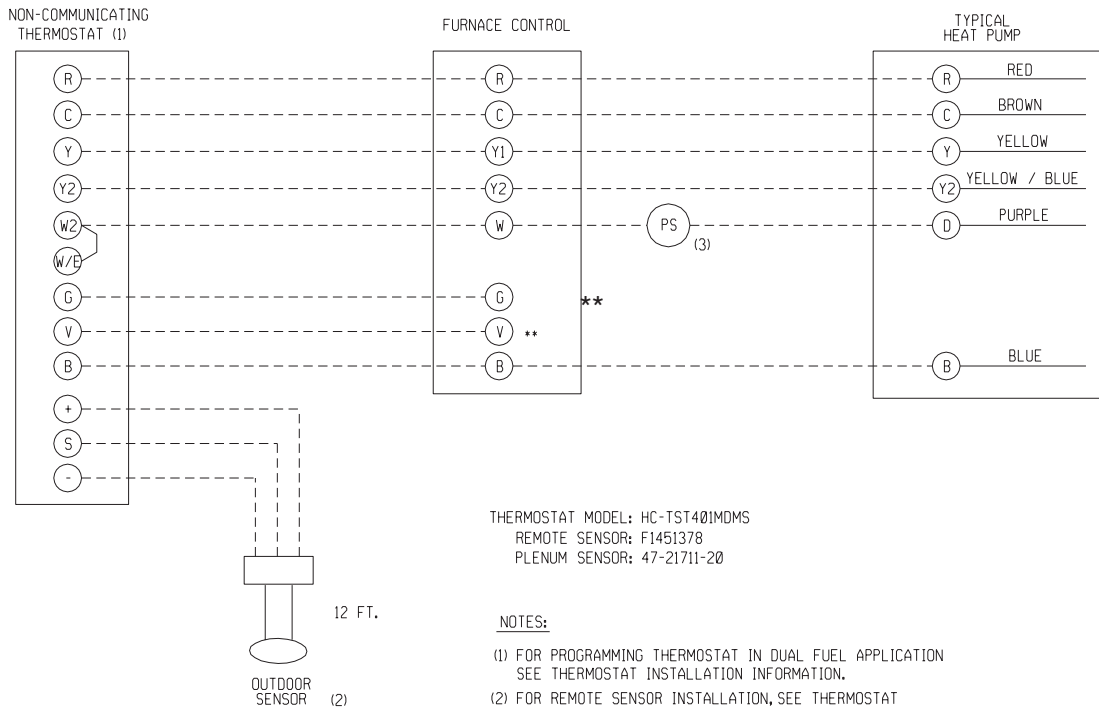

ST-A1169-01

****WARNING: DO NOT APPLY 24VAC TO THE V/W2 TERMINAL ON THE IFC (THIS IS OFTEN DONE DURING SETUP, TROUBLESHOOTING AND/OR DIAGNOSING PROBLEMS). DOING SO WILL DAMAGE THE THERMOSTAT.**

FIGURE 56
WIRING DIAGRAM FOR SINGLE-STAGE HEAT (NON-COMMUNICATING)

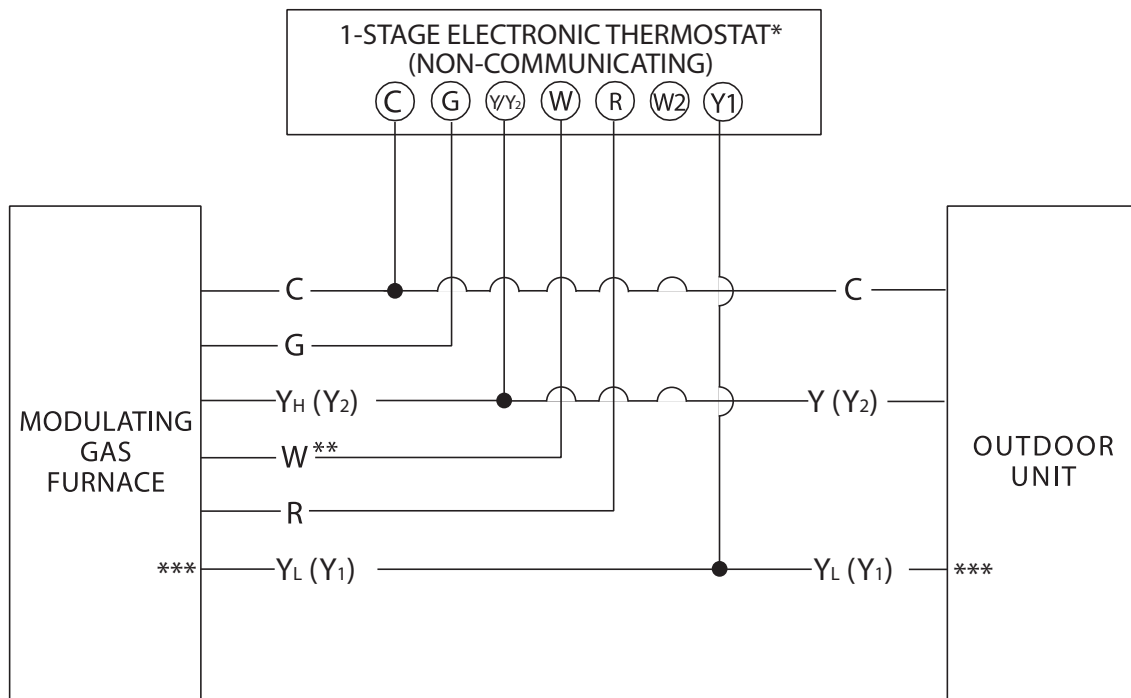

- * NO MECHANICAL THERMOSTATS.
- ** 40%, 65%, and 100% FIRING RATE IN SINGLE-STAGE OPERATION. 40% FIRING RATE IN TWO-STAGE OPERATION (DIP SWITCH SET SW2 — SWITCHES 2 & 3 OFF).
- *** 2 STG. COOLING ONLY.

FIGURE 57
WIRING DIAGRAM FROM TWO-STAGE HEAT (NON-COMMUNICATING)

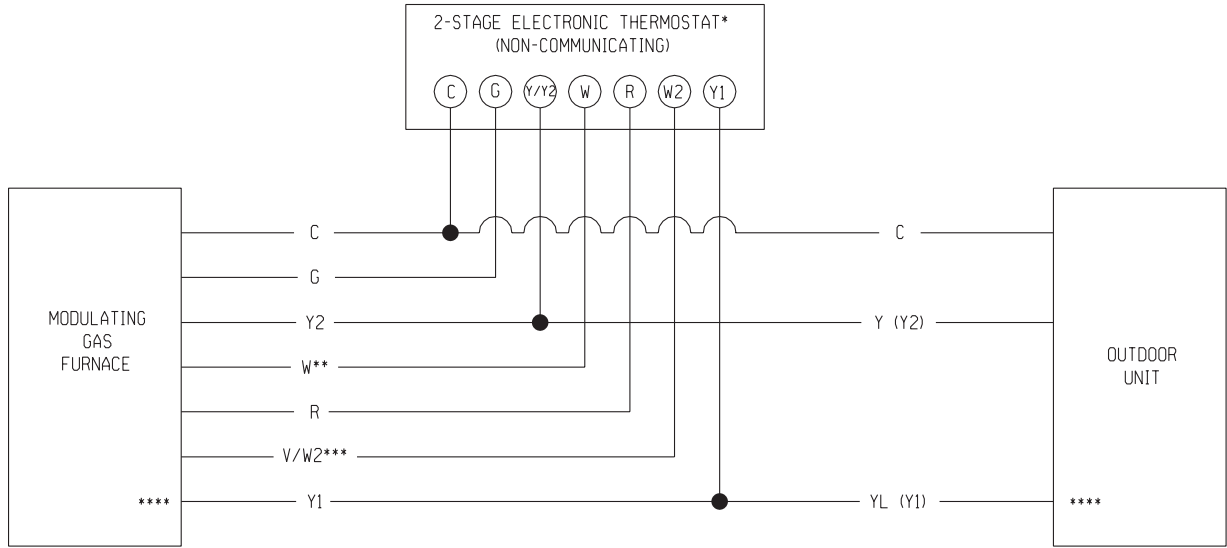

* NO MECHANICAL THERMOSTATS.

** 40% FIRING RATE IN TWO-STAGE OPERATION
 (DIP SWITCH SET S2 - SWITCHES 1 & 2 ON).

*** 65% AND 100% FIRING RATE IN TWO-STAGE OPERATION
 (W & W2 ENERGIZED).

**** TWO-STAGE COOLING ONLY

ST-A1170-01

FIGURE 58
WIRING DIAGRAM – SPECIAL CONFIGURATION: COMMUNICATING THERMOSTAT AND FURNACE WITH NON-COMMUNICATING CONDENSER

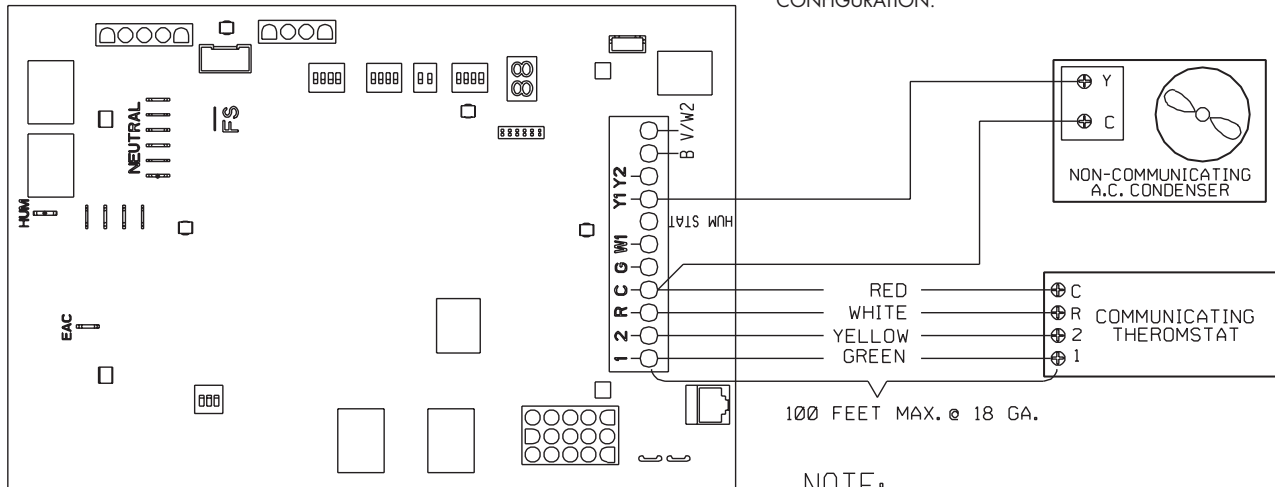

NOTE:
 DEHUMIDIFICATION FUNCTION FROM A COMMUNICATING THERMOSTAT WILL NOT BE POSSIBLE WITH THIS CONFIGURATION.

NOTE:
 THIS CONFIGURATION IS VALID FOR A.C. CONDENSERS ONLY. HEAT PUMP CONDENSERS CAN NOT BE INSTALLED IN THIS CONFIGURATION BECAUSE THERE IS NO CONTROL OUTPUT FOR A REVERSING VALVE AVAILABLE

ST-A1173-01

FURNACE OPERATION WITH A TWO-STAGE THERMOSTAT

To set the furnace for operation with two-stage non-communicating thermostats, set switches 2 & 3 of SW2 to the "ON" position (See Figure 41). Note that these switches should be in the "OFF" position from the factory. With both switches in the "ON" position, the furnace can still recognize a "V" signal present and will still operate with a modulating thermostat. However, with both switches of SW2 in the "ON" position, the furnace is set to operate with a two-stage thermostat as well.

With a two-stage non-communicating thermostat (installed as shown in Figure 60) and switch settings configured as described above, during a call for heat, the furnace will operate as follows:

First Stage

("W"=ON and "W2"=OFF)

40% of furnace capacity always

Second Stage

("W"=ON and "W2"=ON)

Phase 1: 0 to 5 minutes = 65% of furnace capacity

Phase 2: After 5 minutes = 100% of furnace capacity

NOTE: If the call for heat ends during any phase and/or stage, the furnace will terminate immediately at the firing rate of that phase and/or stage.

APPLICATIONS

MODULATING TOUCH-SCREEN NON-COMMUNICATING THERMOSTAT

24 VOLT CONTROL

INSTALLATION

▲ WARNING

THERMOSTAT INSTALLATION AND ALL COMPONENTS OF THE CONTROL SYSTEM SHALL CONFORM TO CLASS II CIRCUITS PER THE NEC CODE.

FIGURE 59
(-)HC-TST412MDMS BASE

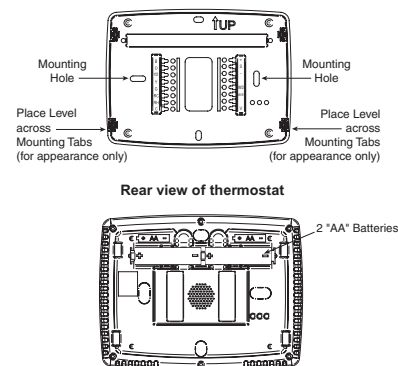

Model	Programming Choices		
(-)HC-TST412MDMS	Non-Programmable	5/1/1 Day	7 Day

THERMOSTAT APPLICATION GUIDE

Description	
Modulating PWM output, gas furnace	Yes
Heat Pump (with Aux. or Emergency Heat), 2 Stage	Yes
Systems with up to 3 Stages Heat, 2 Stages Cool	Yes
Heat Only Systems	Yes
Wired Remote Temperature Sensor (Indoor/Outdoor)	Yes
Dual Fuel Feature (Heat Pump Mode)	Yes

For complete product specifications, see the Installation Instructions supplied with thermostat.

FIGURE 56
(-)HC-TST412MDMS
MODULATING TOUCHSCREEN THERMOSTAT

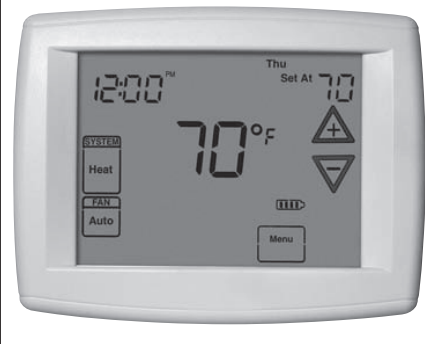

REMOVE OLD THERMOSTAT

A standard heat/cool thermostat consists of three basic parts:

1. The cover, which may be either a snap-on or hinge type.
2. The base, which is removed by loosening all captive screws.
3. The switching subbase, which is removed by unscrewing the mounting screws that hold it on the wall or adapter plate. **Before removing wires from old thermostat, label each wire with the terminal designation from which it was attached.** Disconnect the wires from the old thermostat one at a time. **Do not let wires fall back into the wall.**

INSTALLING NEW THERMOSTAT

1. Pull the thermostat body off the thermostat base. Forcing or prying on the

thermostat will cause damage to the unit. Rear view of thermostat

2. Place base over hole in wall and mark mounting hole locations on wall using base as a template.
3. Move base out of the way. Drill mounting holes. If you are using existing mounting holes and the holes drilled are too large and do not allow you to tighten base snugly, use plastic screw anchors to secure the base.
4. Fasten base snugly to wall using mounting holes shown in Figure 59 and two mounting screws. Leveling is for appearance only and will not affect thermostat operation.
5. Connect wires to terminal block on base using appropriate wiring schematic (see Figures 53 through 55).
6. Push excess wire into wall and plug hole with a fire resistant material (such as fiberglass insulation) to prevent drafts from affecting thermostat operation.
7. Carefully line the thermostat up with the base and snap into place.

BATTERY LOCATION

2 "AA" alkaline batteries are included in the thermostat at the factory with a battery tag to prevent power drainage. Remove the battery tag to engage the batteries. To replace batteries, set system to **OFF**, remove thermostat from wall and install the batteries in the rear along the top of the thermostat (see Figure 59).

WIRING CONNECTIONS

Refer to equipment manufacturers' instructions for specific system wiring information. After wiring, see CONFIGURATION section for proper thermostat configuration. For wiring diagrams, see Figures 53 through 55.

Wiring diagrams shown are for typical systems and describe the thermostat terminal functions.

TERMINAL DESIGNATION DESCRIPTIONS

Terminal Designation	Description
B	Changeover valve for heat pump energized constantly in heating
O	Changeover valve for heat pump energized constantly in cooling
Y2	2nd Stage Compressor
Y	Compressor Relay
G	Fan Relay
RC	Power for Cooling
RH	Power for Heating
C	Common wire from secondary side of cooling
V	PWM Output
W/E	Heat Relay/Emergency Heat Relay (Stage 1)
W2	2nd Stage Heat (3rd Stage Heat in HP2)
-	Common (DC) for wired remote temperature sensor
S	Frequency signal from remote temperature sensor
+	Power (DC) to remote temperature sensor

THERMOSTAT QUICK REFERENCE

Home Screen Description

Figure 61 – Home Screen Display

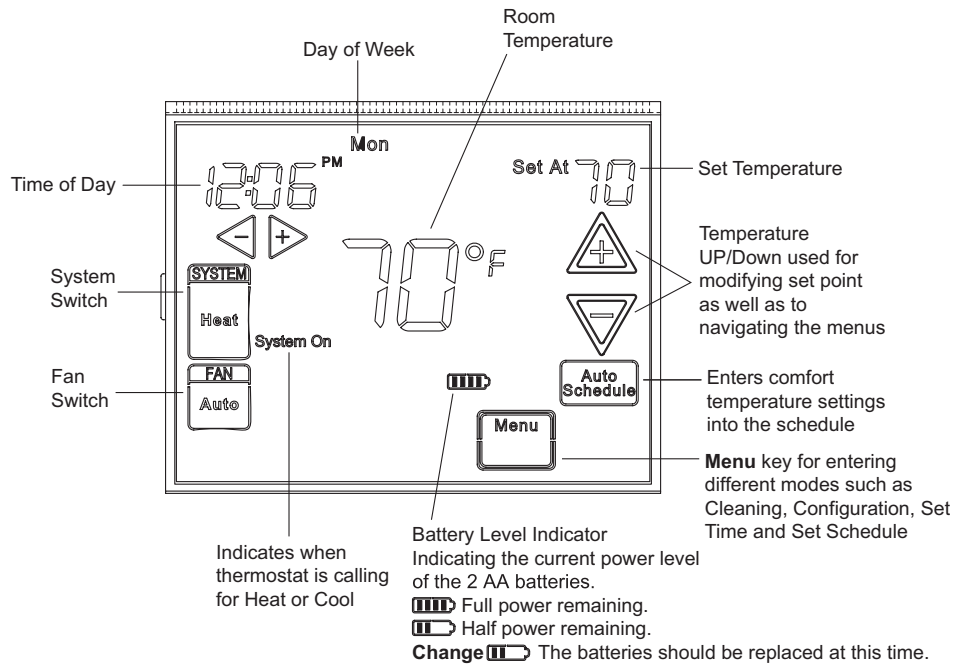

Programming and Configuration Items

- ① Displays and "Keypad Lockout" when in keypad lockout mode. Displays and "Temperature Limit" and "Keypad Lockout" when limited range is activated and locked. Displays only "Temperature Limit" when limited range is activated.
- ② Indicates period of day being programmed.
- ③ RUN SCHEDULE (run program) button.
- ④ SET TIME button or HOLD temperature button.
- ⑤ Displays "Change Filter" when the system has run for the programmed filter time period as a reminder to change or clean your filter.
- ⑥ COPY button or INSTALLER CONFIG button.
- ⑦ CLEAN DISPLAY button allows 30 seconds to wipe off the display or ADVANCE DAY button for programming.
- ⑧ Used in programming to set time and in configuration menu to change selections.
- ⑨ "Hold Until" indicates the time when a temporary hold period will end.
- ⑩ "Hours" and "Days" displays during steps in installer configuration.
- ⑪ The words "Hold At" are displayed when the thermostat is in the HOLD mode. "Temporary Hold At" is displayed when the thermostat is in a temporary HOLD mode.
- ⑫ "System On" indicates when heating or cooling stage is energized. "+2" also indicates when a second stage is energized.

Figure 62 – Programming & Configuration Items

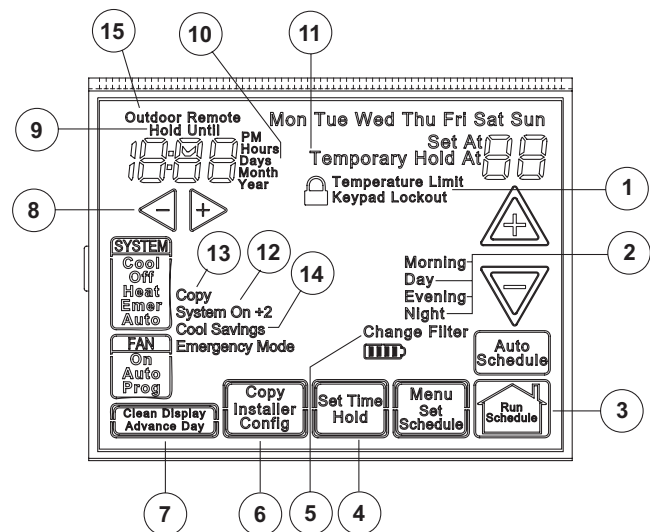

- ⑬ "Copy" indicates the copy program feature is being used during programming.
- ⑭ A steady "Cool Savings" display indicates the feature is enabled in the installer menu. A flashing "Cool Savings" display indicates the feature is active.
- ⑮ "Remote" indicates that the indoor remote temperature sensor, is being accessed. "Outdoor Remote" indicates the outdoor remote temperature sensor is being accessed.

INSTALLER/CONFIGURATION MENU













To enter the menu: Press the **Menu** touch key. Press and hold for 5 seconds the **Installer Config** touch key. This displays menu item #1 in Table 25 below. Press  to advance to the next menu item or  to return to a previous menu item. Press  or  to change a menu item.

TABLE 25: CONFIGURATION MENU						
Menu Reference Number	Programmable	Non-Programmable	Press Button	Displayed (Factory Default)	Press  or  to select from listed options	Comments
1	1	1		MS 2	HP 1, HP 2, SS 1	Selects Multi-Stage (MS 2, No Heat Pump), Heat Pump 1 (HP 1, 1 compressor), Heat Pump 2 (HP 2, 2 compressor or 2 speed compressor), or Single Stage.
2	2	2		(GAS)	ELE	GAS setting: furnace controls blower. ELE setting: thermostat controls blower.
3	3	3		Days, (7) P	5-1-1 or 0	Programs per week. (0 = non-programmable)
4	4	NA		PS (4) Morning, Day, Evening, Night	2 Day, Night	Program periods per day. 4 = Morning, Day, Evening, Night 2 = Day, Night
5	5	4		Cool-Off-Heat-Auto	Cool-Off-Heat, Off-Heat, Cool-Off	System switch configuration in non heat pump mode.
				Cool-Off-Heat-Emer-Auto	Cool-Off-Heat-Emer, Off-Heat-Emer, Cool-Off	System switch configuration, heat pump mode.
6	6	NA		E (On)	OFF	Selects Energy Management Recovery, E (with programming option on)
7	7	5		Cr, Heat (FA)	SL	Selects Adjustable Anticipation, cycle rate, Heat
8	8	6		Cr, Cool (FA)	SL	Selects Adjustable Anticipation, cycle rate, Cool
9	9	7		Cr/AU, Emer (FA)	SL	Selects Adjustable Anticipation, cycle rate auxiliary, (This item is only to appear if HP 1 or HP 2 is selected above).
10	10	8		CL (OFF)	On	Selects Compressor Lockout.
11	11	9		dL (On)	OFF	Selects Continuous Display backlight & intensity.
12	12	10		dL (LO)	HI	Selects Backlight Intensity.
13	13	11		0	4, LO to 4, HI	Selects Adjustable Ambient Temperature Display [range -4 (LO) to +4 (HI)].
14	14	12		F	C	Selects F/ C Display (temperature units in Fahrenheit or Celsius).
15	15	13		b (On)	OFF	Selects audible Beeper On/Off.
16	16	14		dS (On)	OFF	Selects Daylight Saving Time calculation.
17	17	15		AS, Heat (OFF)	On	Selects Automatic Schedule for comfort temperature Programming, heat mode.
18	18	16		AS, Cool (OFF)	On	Selects Automatic Schedule for comfort temperature Programming, cool mode.
19	19	17		CS, (OFF) Cool Savings	1-2-3-4-5-6	Selects Cool Saving Feature & amount.
20	20	18		HL, Heat (99)	62-98	TEMPERATURE LIMIT, HEAT (max. heat set point).
21	21	19		LL, Cool (45)	46-82	TEMPERATURE LIMIT, COOL (min. cool set point).
22	22	20		OFF,  Keypad Lockout	L (total), P (partial), Temperature Limit (limited temperature range)	Selects Keypad Lockout.
				000	001-999	Selects Keypad Lockout Combination (active only if keypad Lockout is selected).
23	23	21		FS, Heat (On)	OFF	Fast second stage of heat (not available if SS1 is selected above).
24	24	22		FS, Cool (On)	OFF	Fast second stage of cool (not available if SS1 or HP1 is selected above).
25	25	23		Remote (OFF)	On	Remote temperature sensor, enable/disable.
				In, Remote	Outdoor Remote	Remote temperature sensor (Indoor/Outdoor).
				LS (On)	OFF	Local temp. Sensor enable/disable (only when Indoor Remote is selected On).
26	26	24		dF (5)	5-50	Selects Dual Fuel Feature & setpoint (in Fahrenheit) (applicable only when HP1 or HP2 is selected).
				Cd (15)	0-99	Selects Compressor delay in seconds (only when dF is selected >5).
27	27	25		AO (80)	35 to 80	Selects Auxiliary Off setpoint (applicable only when HP1 or HP2 is selected).
28	28	26		Change Filter (OFF)	On	Selects Change filter feature
				200 Hours	25-1975 (in increments of 25 hours)	Change filter, duration hours.

INSTALLER/CONFIGURATION MENU

- 1) This control can be configured for:
 MS2 Multi-Stage System (2 heat/2 cool)
 HP1 Heat Pump with one stage of compressor (2 heat/1 cool)
 HP2 Heat Pump with two stage compressor or two compressor system, Gas or Electric backup; (Dual Fuel see menu item 35) (3 heat/2 cool)
 SS1 Single Stage System (3 wire zone see wiring diagram 37-6808A)
- 2) GAS or Electric (ELE) fan operation. If the heating system requires the thermostat to energize the fan, select ELE. Select GAS if the heating system energizes the fan on a call for heat. **Note: Resetting the thermostat switches the option to ELE.**
- 3) **Programs per week** This control can be configured for 7 independent day or 5/1/1 day programming or non-programmable modes. Default is 7-day mode. The display indicates "**7 Days**" as default. Other options "**5 Days**" or "**0 Days**" can be selected by pressing touch keys, \triangleright or \triangleleft . If "**0 Days**" is selected for non-programmable mode, the step for EMR will be skipped, as this feature will not be available in this mode.
- 4) **Program Steps per day** This control can be configured for 4 or 2 program steps per day. Default is "**4 PS**" and can be toggled between 4 PS and 2 PS by pressing the \triangleright or \triangleleft touch keys.
- 5) **System Switch Configuration (MS2/SS1)** This thermostat is configured for Heat and Cool with Auto changeover default (Cool-Off-Heat-Auto). Can be configured as Heat & Cool (Cool-Off-Heat), or Heat Only (Off-Heat), or Cool Only (Cool-Off).
 When the control is in heat pump configuration (**HP1/HP2**), the system switch configuration will have an additional mode available namely, **Emer** for **Emergency Mode**.
- 6) **Energy Management Recovery (EMR)** (this step is skipped if configured as non-programmable).
 When set to "On" causes the thermostat to start heating or cooling early to make the building temperature reach the program setpoint at the time you specify.
Example: Let us say, the heating program is 65 F at night and 70 at 7 AM. If the building temperature is 65 F, the difference is 5 F. Allowing 5 minutes per F rise, the thermostat setpoint will change to 70 at 6:35 AM.
 Cooling allows more time per F, because it takes longer to reach temperature.
- 7, 8 & 9) **Cycle Rate Selection** The factory default setting is fast cycle (FA Cr) in all modes (Heat, Cool, Emer). To slow cycling (SL, Cr), press touch keys \triangleright or \triangleleft toggle between FA & SL. The cycle rates are as below different selections:

Mode	Fast rate	Slow rate
Heat	0.6 F	1.2 F
Cool	1.2 F	1.7 F
Emer	1.2 F	1.7 F
- 10) **Select Compressor Lockout (CL)** Selecting CL On will cause the thermostat to wait 5 minutes between cooling cycles. This is intended to help protect the compressor from short cycling. Some of the newer compressors have already got a time delay built in and do not require this feature to be activated in the thermostat. Your compressor manufacturer can tell you if this lockout feature is already present in their system. When the thermostat compressor time delay is activated, it will flash the set point for up to five minutes.
- 11) **Select Continuous Backlight** In low lighting conditions, display backlight improves the display contrast. When **C** terminal is connected, selecting dL On will turn the backlight on continuously. Selecting dL Off will turn the backlight on momentarily after any key is pressed. When **C** terminal is not powered (battery only), dL On enables the momentary backlight whenever a key is pressed.
- 12) **Select Backlight Intensity** This thermostat has the ability to provide two selectable intensities of the backlight: HI and LO. Using \triangleright or \triangleleft touch keys you can toggle the selection between HI and LO.
- 13) **Select Temperature Display Adjustment 4 LO to 4 HI** This allows you to adjust the room temperature display by an amount in the range of -4 F to +4 F in 1 steps by using the \triangleright or \triangleleft touch keys. Your thermostat was accurately calibrated at the factory, however you have the option to change the display temperature value to match your previous thermostat, if you so prefer.
- 14) **Select °F or °C Readout** Select the desired temperature unit by pressing \triangleright or \triangleleft . Factory default is F.
- 15) **Select Audio Prompting (Beeper) On or Off** Factory default setting is on (**b, On**). If you wish to turn off the beeper select OFF.
- 16) **Select Daylight Saving Time Calculation** This feature will allow the thermostat to calculate the DST automatically and apply it to the Real Time Clock display. Default On. Use \triangleright or \triangleleft touch keys to select the feature, OFF.
- 17 & 18) **Select Automatic Schedule** With just one touch of the **Auto Schedule** key this feature allows you to program a desired comfort temperature into all the program periods along with a 6 set back for night periods of both Heat and Cool programs. Factory default is "On" for both. When **Heat AS On** and **Cool AS On** are activated while in Heat or Cool mode, select desired setpoint temperature and press **Auto Schedule**. **Auto Schedule** will flash, press it again to copy. This value will be copied into all the morning, day and evening program periods. The night program periods will be with a 6 F set back.
- 19) **Select Cool Savings™:** With Cool Savings enabled, the thermostat will make small adjustments to the sensed temperature during periods of high demand to reduce AC system running time and save energy. When the cooling system has been running for more than 20 minutes, humidity in the home will be lower and a higher temperature will feel comfortable. After 20 minutes of run time, the thermostat will start decreasing the sensed temperature in steps of less than one degree as the system continues to run. These adjustments will eventually cause the system to satisfy the thermostat to turn the system off and reduce the energy consumption. When the Cool Savings feature is active and making adjustments, the display will flash **CoolSavings™**. The amount of the adjustments to the sensed temperature is dependent on the Cool Savings value that is set, 1 being the least adjustment and 6 being the most adjustment. With this feature set to OFF, no change will occur when the AC system is continuously running during the periods of high demand. Periods of high demand will normally occur during the late afternoon and early evening on the hottest days of the summer. As demand lessens the adjustments to sensed temperature are reversed until sensed temperature returns to normal and **"CoolSavings™"** no longer flashes.

INSTALLER/CONFIGURATION MENU

- 20) **Heat Temperature Limit Range** This feature adjusts the highest setpoint temperature for heat. The default setting is 99 F. It can be changed between 62 F and 98 F by pressing the \triangleright or \triangleleft key. The "temperature limit" icon will be displayed to the left of your setpoint temperature when using this feature. The "temperature limit" icon will flash if an attempt is made to adjust the temperature beyond the range selected.
- 21) **Cool Temperature Limit Range** This feature adjusts the lowest setpoint temperature for cool. The default setting is 45 F. It can be changed between 46 F and 82 F by pressing the \triangleright or \triangleleft key. The "temperature limit" icon will be displayed to the left of your setpoint temperature when using this feature. The "temperature limit" icon will flash if an attempt is made to adjust the temperature beyond the range selected.
- 22) **Keypad Lockout** This step allows you to select the type of lockout or limited range security required. If no lockout or limited range security is required, press \triangleup to advance the menu. Three security settings are available in this menu item. Use the \triangleright or \triangleleft keys to select the lockout desired. Lockout selections are:
"Keypad Lockout and L" = Total Lockout. Total Lockout locks all keys.
"Keypad Lockout and P" = Partial Lockout. Partial Lockout allows only the \triangleup or ∇ keys to operate within your set temperature limits.
"Temperature Limit/Keypad Lockout" prevents changing the temperature limits in the Configuration Menu.
Keypad Lockout Combination Number Selection
Display will read "OFF" "Keypad Lockout".
Skip this step and continue through the configuration menu items 19 thru 22 if you require an Air Filter Change out indicator or Humidifier Pad Change out indicator by pressing the \triangleup button to advance.
Return to this point when you are ready to start your selected lock-out and continue by:
Pressing \triangleright or \triangleleft keys to select ON.
Press \triangleup . Display will read "000".
Pressing \triangleright or \triangleleft keys to select your keypad lockout combination number. Note: "000" is not a valid combination choice.
Record the number you select for future use.
Press \triangleup to exit the menu. The security feature you select will start in 10 seconds. The system button will remain active for 10 seconds to allow setting Heat, Off, Cool or Auto.
- 23 & 24) **Select Fast Second Stage ON or OFF** In the run mode, with the fast Heat feature enabled (FA Heat On), if the Heat setpoint temperature is manually raised by 3 F (2 C) or more above the actual temperature using \triangleup the second stage will energize immediately. With FA OFF, second stage will not energize until the setpoint temperature is 1 F or more above actual temperature for more than ten minutes. The Fast Cool feature (FA Cool) provides the same controls when the setpoint temperature is lowered.
- 25) **Select Remote Temperature Sensor** This control allows one wired remote temperature sensor (indoor or outdoor) be connected to it and indicates the measured temperature in clock digits. This menu enables you to select the remote sensor and also configure it as indoor or outdoor temperature sensor. Factory default is off. Select **Remote On** and **Remote in** (for indoor) or **Outdoor Remote**.
Local Temperature Sensor disable This is applicable only when indoor remote temperature sensor is enabled. Factory default is **On LS**. You can make it **Off LS** if you desire by using \triangleright or \triangleleft touch keys. Then, only the indoor remote temperature reading will be used for control.
- 26) **Select Dual Fuel Feature and Setpoint** This feature is applicable only in heat pump modes. When the feature is selected, the thermostat will switch to gas heat and inhibit the compressor when the outside temperature (monitored by the outside remote sensor), falls below the DF setpoint. By using \triangleright or \triangleleft touch keys, select **x, DF** where x=5 to 50; factory default is 5 which disables the feature. This feature requires an outdoor remote temperature sensor (WR# F145-1378), however does not need a fossil fuel kit.
Select Compressor Delay When the DF feature is enabled, the shut down of the compressor stage(s) are delayed by a programmable time after the auxiliary stage is energized to minimize the duration during which the system may blow cooler air. Default delay is 60 seconds (60, Cd). By using \triangleright or \triangleleft touch keys any value between 0 and 99 can be selected.
- 27) **Select Auxiliary Offset Point** This feature is applicable only in heat pump modes. When the outdoor temperature is above the Auxiliary Off (**AO**) setpoint, the auxiliary stages will be inhibited so the temperature will be maintained by only the heat pump. Factory default is 80, which disables the feature. AO setpoint cannot be set at or below Dual Fuel (DF) setpoint. By using \triangleright or \triangleleft touch keys, select **x, AO** where x=35 to 80.
- 28) **Select Change Filter Run Time** The thermostat will display "Change Filter" after a set time of blower operation. This is a reminder to change or clean your air filter. This time can be set from 25 to 1975 hours in 25 hour increments. A selection of OFF will cancel this feature. When "Change Filter" is displayed, you can clear it by pressing Clean Display. In a typical application, 200 hours of run time is approximately 30 days.

OPERATING YOUR THERMOSTAT ————— IMPORTANT!

Choose the Fan Setting (Auto or On or Prog)

Fan **Auto** is the most commonly selected setting and runs the fan only when the heating or cooling system is on.

Fan **On** selection runs the fan continuously for increased air circulation or to allow additional air cleaning.

Fan **Prog** will cycle the fan for -10 minutes on and 20 minutes off if the thermostat has not called for heat or cool during the past 60 minutes.

Choose the System Setting (Cool, Off, Heat, Emer, Auto)

Press the SYSTEM button to select:

Heat: Thermostat controls only the heating system.

Off: Heating and Cooling systems are off.

Cool: Thermostat controls only the cooling system.

Auto: Auto Changeover is used in areas where both heating and cooling may be required on the same day. **AUTO** allows the thermostat to automatically select heating or cooling depending on the indoor temperature and the selected heat and cool temperatures. When using **AUTO**, be sure to set the Cooling temperatures more than 1 Fahrenheit higher than the heating temperature.

Emer: Setting is available only when the thermostat is configured in HP1 or HP2 mode.

Manual Operation for Non-Programmable Mode Thermostats

Press the SYSTEM button to select Heat or Cool and use the Δ or ∇ buttons to adjust the temperature to your desired setting. After selecting your desired settings you can also press the SYSTEM button to select **AUTO** to allow the thermostat to automatically change between Heat and Cool.

Manual Operation (Bypassing the Program) Programmable Thermostats

Press Δ or ∇ and the HOLD button and adjust the temperature wherever you like. This will override the program. The **HOLD** feature bypasses the program and allows you to adjust the temperature manually, as needed. Whatever temperature you set in **HOLD** will be maintained 24 hours a day, until you manually change the temperature or press **Run Schedule** to cancel **HOLD** and resume the programmed schedule.

Program Override (Temporary Override)

Press Δ or ∇ buttons to adjust the temperature. This will override the temperature setting for a (default) four hour override period. The override period can be shortened by pressing \triangleleft or lengthened by pressing \triangleright . Program Override period can range from 15 minutes to 7 days.

Example: If you turn up the heat during the morning program, it will be automatically lowered later, when the temporary hold period ends. To cancel the temporary setting at any time and return to the program, press **Run Schedule**. If the SYSTEM button is pressed to select **AUTO** the thermostat will change to Heat or Cool, whichever ran last. If it switches to heat but you want cool, or it changes to cool but you want heat, press both Δ or ∇ buttons simultaneously to change to the other mode.

Special Test Mode for PWM (V) output (Installer function only)

The PWM (V) output controls the modulating gas valve. Amplitude of this signal is about 10 VDC, frequency is 1 HZ and the pulse width is variable 350 to 950 in steps of 50 msec.

To activate the modulating test mode, press and hold the **Installer Config** touch key until the display changes to show **dC** (in actual temperature digits) and **05** (default) in clock digits (at least 10 seconds). If the touch key is released before the display changes the test mode will not be activated and the installer menu mode will be active. On entering the modulating test mode, the display (**05**) will indicate the duty cycle of 5% (pulse width of 50 msec) corresponding to no call for heat.

Press \triangleright key to change the display to **35** (duty cycle 35%). The **W** output will energize and within one second the pulse width modulated **V** output will also be activated with a pulse width of 350 msec.

Use \triangleright or \triangleleft touch keys to increase or decrease the pulse width in steps of 50 milliseconds (5% change in duty cycle). The maximum duty cycle is 95% (maximum pulse width of 950 milliseconds).

This special test mode will be exited by pressing **Run Schedule** touch key or when there is no keypad activity for over 60 minutes.

PROGRAMMING

Set Current Time and Day

- 1) Press Menu key to enter installer menu. Then press Set Time once to indicate hour & A or P designation in clock display.
- 2) Press and hold either the \triangleright or \triangleleft touch key until you reach the correct hour and A or P designation.
- 3) Press Set Time again to display minutes only in clock display.
- 4) Press and hold either the \triangleright or \triangleleft touch keys until you reach the correct minutes.
- 5) Press Set Time once again to display year.
- 6) Press and hold either the \triangleright or \triangleleft touch key until you reach the correct year.
- 7) Press Set Time once again to display month.
- 8) Press and hold either the \triangleright or \triangleleft touch key until you reach the correct month.
- 9) Press Set Time once again to display date of the month along with day of the week at top row (which is automatic).
- 10) Press and hold either the \triangleright or \triangleleft touch key until you reach the correct day of the month. The correct day of the week is displayed at the top row.
- 11) Press Run Schedule once; now the display will show the correct time and room temperature.

PROGRAMMING

Automatic Daylight Saving Calculation

The Real Time Clock will adjust automatically for daylight savings time, in the following manner until 2007: Increment one hour at 2 AM on the first Sunday of April and decrement one hour at 2 AM of the last Sunday of October every year.

From March 2007, the adjustment will occur every year as follows: Increment one hour at 2 AM on the second Sunday of March and decrement one hour at 2 AM on the first Sunday of November.

The daylight saving feature can be enabled or disabled in installer configuration mode.

After entering installer configuration mode, momentarily press Δ or ∇ touch key until the display indicates dS (in actual temperature digits) and on (default in c lock digits). \triangleright and \triangleleft keys will toggle display and operation from On to OFF.

Programming Tip: Copy Button

You may copy any daily program to another day or group of days by pressing the Copy button. In 7 day programming mode when the Copy button is pressed, the other 6 days of the week will flash. To copy the current program into the remaining six days, simply press the Copy button again. To copy the current program to another day of the week, press Advance Day to select the day and press Copy to paste the program. In 5/1/1 day programming mode the copy function is similar. The weekday (Mon-Fri) program can be copied to Sat and Sun (both flashing) or use Advance Day to choose Sat or Sun and press the Copy button to paste the program.

Fill in the blank schedule on the next page then:

Enter the Heating Program

- 1) Press the Menu button and then press Set Schedule. Press SYSTEM button to select either "Heat" or "Cool" in the system switch area indicating the active mode being programmed. You can switch to the other mode by pressing the system switch at any time.
- 2) The top of the display will show the day(s) being programmed. The time and set at temperature are also displayed. "Morning" will also be displayed to indicate the period.
- 3) Press Δ or ∇ key to change the temperature to your selected temperature for the 1st heating period (Morning).
- 4) Press \triangleright or \triangleleft key to adjust the start time for period. The time will change in 15 minute increments.
- 5) Press FAN to select Auto or Prog.
- 6) After you have set the time and the temperature for the period to begin, press Set Schedule to advance to the next program period.
- 7) Repeat steps 2 through 6 until all of the program times and temperatures are set for all program periods on that day.
- 8) Press "Advance Day" to change to the next day and repeat steps 2 through 8.
- 9) When programming is complete and all of the times and temperatures match your desired heating schedule, press Run Schedule. The thermostat will now run your program.

Enter the Cooling Program

- 1) Press the SYSTEM button until the Cool icon appears.
- 2) Follow Enter Heating Program instructions for entering cooling times and temperatures.

Automatic Schedule

This feature provides a method to program every day with the most popular time and temperature profile using one key press. For this feature to be available, the Auto schedule options (**AS Cool** or **AS Heat**) should be set on in the installer configuration.

Select the desired Comfort Temperature in the setpoint. When the **Auto Schedule** touch key is pressed, it will start flashing indicating that it is now ready to insert the displayed temperature setpoint as the Comfort Temperature for the selected system mode currently in (Heat/Cool). A second press of the **Auto Schedule** touch key will complete the process. A 6° F setback temperature will also be inserted for the night step. Once it is done, the touch key display **Auto Schedule** will disappear disabling any further operation of **Auto Schedule** touch key. If desired it can be enabled again in the installer configuration menu.

Entering Fan Program

The FAN touch key is used to select **FAN Auto** operation (fan energized with a call for cool but not on with a call for heat) to **FAN On** (fan on continuous) or **FAN PROG** (fan programmed to cycle fixed time automatically). Each press of the FAN touch key will change the mode from **Auto** to **On** to **Prog**. **FAN Auto** or **FAN On** or **FAN On Prog** will display in the run mode for as long as the fan is in that position. When **FAN Prog** position is selected and the system is in the **Cool**, **Heat** or **Auto** mode, the circulator blower (fan) will cycle ON for 10 minutes, OFF for 20 minutes when the thermostat has not called for cooling or heating for the past 60 minutes.

To improve indoor air quality, the system circulator can be programmed to run during any program time period by touching the FAN touch key in the appropriate program time period when in the **Menu** mode for that particular day. The display shall indicate **Prog** (under the FAN icon) when in Menu mode and the fan is programmed to come on during that time.

In the menu mode, each time the fan key is pressed, the fan operation and display will change from **FAN Auto** to **FAN Prog**. The display shall indicate **FAN On Prog** when in run mode and the fan is programmed to run for that particular time period.

When in **Run Schedule** mode and the FAN touch key is pressed, it will override the schedule, and the display and fan operation shall change to **FAN Auto** and the fan is stopped. Further key depression will change it to **FAN On** (continuous blower on) and to **FAN Prog** (cycling 10 minutes on and 20 minutes off if there is no call for heat or cool for 60 minutes). The **Run Schedule** touch key will also be indicated, meaning that it is an override on the scheduled program. The override will last until next schedule comes up or the **Run Schedule** touch key is depressed.

PROGRAMMING

Energy Saving Factory Pre-Program

The (-)HC-TST401MDMS thermostats are programmed with the energy saving settings shown in Table 26 below for all days of the week. If this program suits your needs, simply set the thermostat clock and press the RUN button.

Table 26 below shows the factory set heating and cooling schedule for all days of the week.

Table 26: Pre-Program Settings

	* Wake Up (Morning)		Leave For Work (Day)		* Return Home (Evening)		Go To Bed (Night)	
Heating Program	6:00 AM	70 F	8:00 AM	62 F	5:00 PM	70 F	10:00 PM	62 F
Cooling Program	6:00 AM	78 F	8:00 AM	85 F	5:00 PM	78 F	10:00 PM	82 F

* You can eliminate these two program periods in the configuration menu (reference #3) if the building is occupied all day. Day will change to 6:00 am and can be programmed as required.

Planning Your Program – Important

The Heating and Cooling Program schedules below allow you to pencil in your own program times and temperatures.

The (-)HC-TST401MDMS comes configured for 7 day programming and can also be configured for 5+1+1 programming (see configuration section).

Factory settings are listed on Monday, Saturday and Sunday. If you are re-programming a 5+1+1 day schedule, pencil in your own times and temperatures directly below the factory times and temperatures.

If you are re-programming a 7 day fill in all lines with the times and temperatures you want.

Keep the following guidelines in mind when planning your program.

In Heating, lower temperatures will save energy.

In Cooling, higher temperatures will save energy.

If you plan on using Auto Changeover, do not program the heating higher than the cooling.

Table 27: Worksheet for Re-Programming 5+1+1 and 7 Day Program

Heating Program	Wake Up (Morning)			Leave For Work (Day)			Return Home (Evening)			Go To Bed (Night)		
	Time	Temp	Fan	Time	Temp	Fan	Time	Temp	Fan	Time	Temp	Fan
MON	6:00 AM	70 F	Auto	8:00 AM	62 F	Auto	5:00 PM	70 F	Auto	10:00 PM	62 F	Auto
TUE												
WED												
THU												
FRI												
SAT	6:00 AM	70 F	Auto	8:00 AM	62 F	Auto	5:00 PM	70 F	Auto	10:00 PM	62 F	Auto
SUN	6:00 AM	70 F	Auto	8:00 AM	62 F	Auto	5:00 PM	70 F	Auto	10:00 PM	62 F	Auto

Cooling Program	Wake Up (Morning)			Leave For Work (Day)			Return Home (Evening)			Go To Bed (Night)		
	Time	Temp	Fan	Time	Temp	Fan	Time	Temp	Fan	Time	Temp	Fan
MON	6:00 AM	78 F	Auto	8:00 AM	85 F	Auto	5:00 PM	78 F	Auto	10:00 PM	82 F	Auto
TUE												
WED												
THU												
FRI												
SAT	6:00 AM	78 F	Auto	8:00 AM	85 F	Auto	5:00 PM	78 F	Auto	10:00 PM	82 F	Auto
SUN	6:00 AM	78 F	Auto	8:00 AM	85 F	Auto	5:00 PM	78 F	Auto	10:00 PM	82 F	Auto

PROGRAMMING

Wired Remote Temperature Sensing

One remote temperature sensor can be installed indoor or outdoor and connected to the thermostat by a maximum cable length of 100 meters (300 ft). Three terminals, +, S & - are provided on the terminal block to connect to the White-Rodgers standard wired remote sensor. This sensor will be read by the thermostat only when 24VAC is present.

When used as indoor sensor, the readings can be weighted with the local sensor for specific program periods. User can enable or disable the remote sensor in the installer configuration mode and also the outdoor temperature can be selected to show on the display.

Once in the installer configuration mode, momentarily press the Δ or ∇ touch key until display indicates **Remote** (at the top left of the LCD) and OFF (default in clock digits).

Pressing \triangleright or \triangleleft touch key will toggle the operation and display from **Remote OFF** to **Remote On**.

When **Remote On** is selected, press Δ key for the display to indicate **Remote In** (for indoor remote).

The Δ or ∇ keys will toggle the operation and display from **Remote In** to **Outdoor Remote**.

When any remote is selected the temperature will display in the clock digits for one second alternating with the current time for three seconds when in **Run Schedule** mode.

Outdoor Remote will indicate at the top left of display for outdoor remote reading.

Only **Remote** will show at top left for indoor remote reading. ($^{\circ}$ F or $^{\circ}$ C will not indicate with remote temperature readings).

Sensing Range:

Outdoor temperature range is -40 to 140° F

Indoor temperature range is 32° F to 99° F

Weight of Remote Reading:

When in view schedule mode the weight of the indoor remote sensor will be shown in the left actual temperature digits designated as A2 (default for average weight), H4 (high weight) or L1 (low weight). The period (Morning, Day, Evening, Night) will also be shown to the right of the weight value in the actual temperature digits.

When in view schedule mode, press \triangleright and \triangleleft keys at the same time to sequence the indoor remote temperature sensor weight from A2 to H4 to L1 and back to A2 for each of the program period times for each day. (The H4 weight is twice the weight of A2 and A2 is twice the weight of L1).

When **Remote In** is selected (with **Remote** selected to **On**), press Δ key for the display to indicate the status of the local sensor **LS On** (default for thermostat local sensor operational). The Δ and ∇ keys will toggle the function and display from **LS** (shown in actual temperature digits) and **On** (shown in clock digits) to **LS OFF** to designate the local sensor is disabled.

The local sensor may be disabled only if the indoor remote sensor is enabled and functional.

If the indoor remote sensor is disabled or not functional, the local sensor will automatically enable and display in the run schedule mode.

The actual temperature displayed in the run mode is the mathematical weighted sum of the two temperature sensors local and indoor remote.

(Outdoor remote sensor is not used for this computation).

If the remote sensor is absent or not enabled then the actual temperature will be as measured by the local sensor.

Dual Fuel Temperature Set Point

The Thermostat can monitor outside temperature through an outdoor remote sensor if installed and switch to gas heat and inhibit the compressor when in heat pump mode and outside temperature is below a user selectable value. This temperature is called the dual fuel temperature set point. This eliminates the need for a fossil fuel kit.

For this feature to be functional the following conditions are to be met:

1. The thermostat must be in heat pump mode;
2. The outdoor temperature sensor must be enabled and operational.

Once in the installer configuration mode, step through the menu items until the display indicates **dF** (for dual fuel) in the actual temperature digits and 5 (default) in clock digits.

Pressing the \triangleright or \triangleleft touch keys will increment the dual fuel temperature setpoint from 5 to 50 (default unit is Fahrenheit). When the dual fuel temperature setpoint is any value above 5° F this feature is enabled. If the actual outdoor temperature is lower than this temperature setpoint the heat pump will be inhibited. If the balance point temperature setpoint is 5° F the feature is disabled.

When the dual fuel feature is enabled, the shut down of the compressor stage(s) are delayed a programmable time with a default of 60 seconds after the auxiliary stage is energized to minimize the time that the system may blow cooler air.

Only when the dual fuel feature is enabled and the Δ is pressed after the dual fuel feature **dF** is selected, the display will indicate **Cd** (for compressor delay) in actual temperature digits and 60 (default) in clock digits.

Pressing the \triangleright or \triangleleft touch keys will increment the compressor delay time to 99 seconds or decrement down to 0 second.

If the \triangleright or \triangleleft touch keys are held depressed, the setpoint will increment or decrement one degree at the rate of one degree every one half second for the first three seconds and thereafter at double the speed.



TROUBLESHOOTING

Reset Operation

Note: When thermostat is reset, installer configuration menu settings and programming will reset to factory settings.

If a voltage spike or static discharge blanks out the display or causes erratic thermostat operation, you can reset the thermostat by removing the wires from terminals **R** and **C** (do not short them together) and removing batteries for 2 minutes. After resetting the thermostat, replace the wires and batteries. If the thermostat has been reset and still does not function correctly contact your heating/cooling service person or place of purchase.

Note: Be sure to review the installer configuration menu settings.

To reset the programming, clock and configuration settings, press  and  and the SYSTEM button simultaneously. The thermostat should go blank and then all segments will be displayed momentarily.

Symptom	Possible Cause	Corrective Action
No Heat/No Cool/No Fan (common problems)	<ol style="list-style-type: none"> Blown fuse or tripped circuit breaker. Furnace power switch to OFF. Furnace blower compartment door or panel loose or not properly installed. Loose connection to thermostat or system. 	Replace fuse or reset breaker. Turn switch to ON. Replace door panel in proper position to engage safety interlock or door switch. Tighten connections.
No Heat	<ol style="list-style-type: none"> Pilot light not lit. Furnace Lock-Out Condition. Heat may also be intermittent. Heating system requires service or thermostat requires replacement. 	Re-light pilot. Many furnaces have safety devices that shut down when a lock-out condition occurs. If the heat works intermittently contact the furnace manufacturer or local HVAC service person for assistance. Diagnostic: Set SYSTEM Switch to HEAT and raise the setpoint above room temperature. Within a few seconds the thermostat should make a soft click sound. This sound usually indicates the thermostat is operating properly. If the thermostat does not click, try the reset operation listed above. If the thermostat does not click after being reset contact your heating and cooling service person or place of purchase for a replacement. If the thermostat clicks, contact the furnace manufacturer or a HVAC service person to verify the heating is operating correctly.
No Cool	<ol style="list-style-type: none"> Cooling system requires service or thermostat requires replacement. 	Same as diagnostic for No Heat condition except set the thermostat to COOL and lower the setpoint below the room temperature. There may be up to a five minute delay before the thermostat clicks in Cooling.
Heat, Cool or Fan Runs Constantly	<ol style="list-style-type: none"> Possible short in wiring. Possible short in thermostat. Possible short in heat/cool/fan system. FAN Switch set to Fan ON. 	Check each wire connection to verify they are not shorted or touching together. No bare wire should stick out from under terminal block. Try resetting the thermostat as described above. If the condition persists the manufacturer of your system or service person can instruct you on how to test the Heat/Cool system for correct operation. If the system operates correctly, replace the thermostat.
Thermostat Setting & Thermostat Thermometer Disagree	<ol style="list-style-type: none"> Thermostat thermometer setting requires adjustment. 	The thermometer can be adjusted +/- 4 degrees. See Temperature Display Adjustment in the Configuration Menu section.
Furnace (Air Conditioner) Cycles Too Fast or Too Slow (narrow or wide temperature swing)	<ol style="list-style-type: none"> The location of the thermostat and/or the size of the Heating System may be influencing the cycle rate. 	Digital thermostats provide precise control and cycle faster than older mechanical models. The system turns on and off more frequently but runs for a shorter time so there is no increase in energy use. If you would like an increased cycle time, choose SL for slow cycle in the Configuration menu, step 6 (heat) or 7 (cool). If an acceptable cycle rate is not achieved, contact a local HVAC service person for additional suggestions.
Forgot Keypad Lockout Code		Press the menu button (button will disappear) and hold in for 20 seconds. This unlocks the thermostat.

COMMUNICATING THERMOSTATS

COMMUNICATING THERMOSTATS

The modulating furnace is capable of communicating with a thermostat and condenser to improve cooling and heat-pump airflow, displaying active faults and active furnace information at the thermostat and improved diagnostics and troubleshooting.

WIRING A FURNACE FOR COMMUNICATIONS

MAXIMUM COMMUNICATING WIRE LENGTHS (1, 2, R & C)

Max Wire Length – Thermostat to Furnace = **100 FT @ 18 AWG***

Max Wire Length – Furnace to Condenser = **125 FT @ 18 AWG***

Notes:

1. When using twisted pairs, be sure the wires connected to pins labeled "1" (recommended wire color = green) and "2" (recommended wire color = yellow) are a twisted pair.
2. Wires may be solid or stranded.
3. *Wire gage smaller than 18 AWG is not approved or recommended for this application.
4. When using existing wire from a previous installation, be sure to trim the tip of the wire back past the insulation and strip a small amount of insulation from the wire to expose clean new copper for the communicating connections. Fresh copper must be exposed when making the communicating connections or communications may not be properly established.

Figures 63 and 64 are wiring diagrams for connecting the furnace to an approved ClimateTalk communicating thermostat and approved Rheem or Ruud communicating condenser.

The only approved configuration for fully communicating systems is to install dedicated wires directly from the furnace to the thermostat and a separate set of dedicated wires directly from the furnace to the condenser. Note: The only approved configuration for systems with a communicating condenser requires that four dedicated wires (1, 2, R and C) be installed from the furnace to the condenser.

TWO NOTES ABOUT COMMUNICATING THERMOSTATS

1. When power to the thermostat has been reset and/or the batteries are replaced, the thermostat will respond quickly to changes in room temperature as indicated by the room temperature displayed at the thermostat.

However, after a two-hour period, this will change and the thermostat will take as long as five minutes for every degree F to change the display. Therefore, for example a rapid change of five degrees in room temperature will not be correctly indicated at the thermostat for (up to) 25 minutes. This is done to buffer the thermostat against rapid and insignificant swings in temperature caused by briefly opening a door or window. This operation prevents excessive cycling of the thermostat and is a feature used in all modern thermostats.

2. For dual-fuel systems, once the thermostat has switched over to auxiliary heat (e.g. gas heat), subsequent heat calls may also immediately begin with auxiliary heat regardless of the dual-fuel changeover point and the actual outdoor temperature or the difference between room temperatures and setpoint. This is true as long as the subsequent heat call is within 12 minutes or less of end of the previous heat call. The actual time between heat calls that will cause this operation varies but should not exceed 12 minutes.

FIGURE 63
WIRING DIAGRAM – COMMUNICATING CONFIGURATION

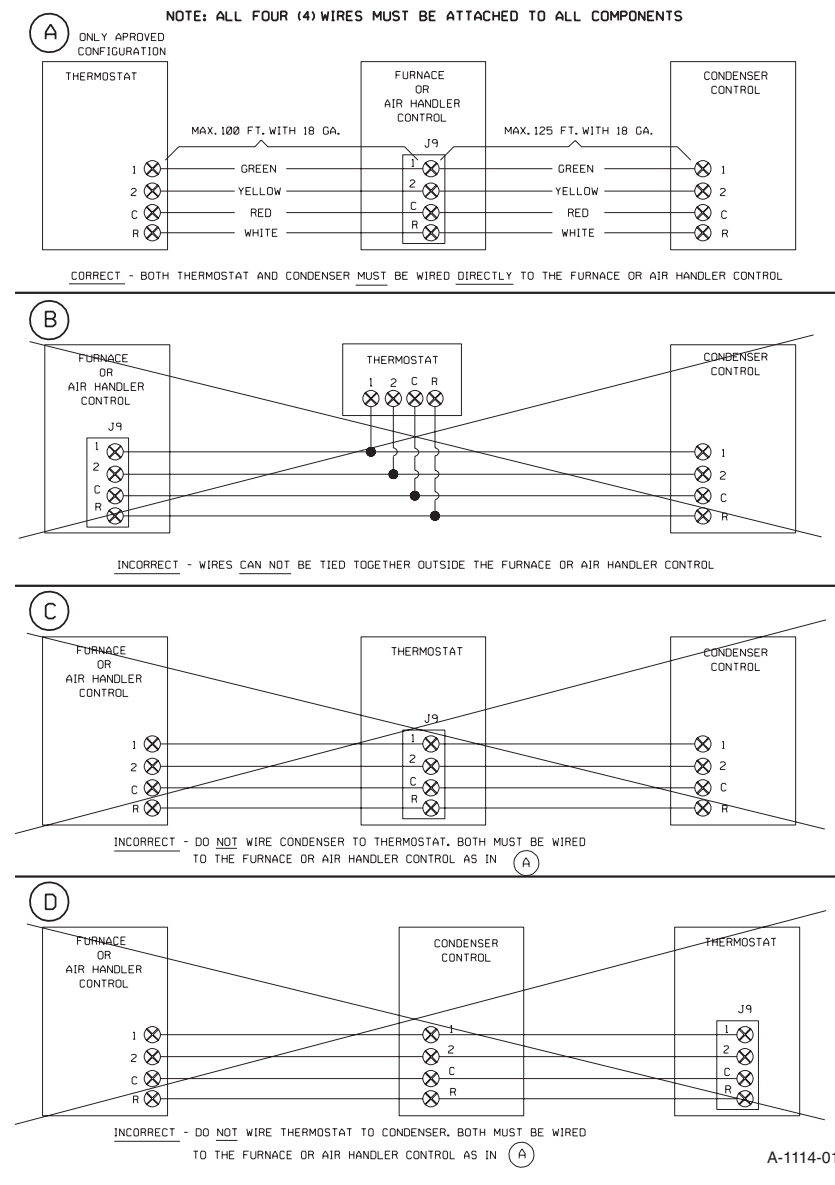

SPECIAL CONFIGURATION – COMMUNICATING THERMOSTAT AND FURNACE WITH A NON-COMMUNICATING CONDENSER

Y1 and Y2 – This terminal may be used to connect directly to a non-communicating condenser when a communicating thermostat is installed to the furnace but a non-communicating condenser is installed in the system. While the optimum configuration is with a communicating condenser connected to the network, there may be installations where this is not desired. In these cases, the thermostat will be communicating with the furnace control and the furnace control will energize the condenser as necessary (the additional relays have been added to the furnace control to allow this operation).

The thermostat connections labeled “Y1” on the I.F.C. is normally an *input* to the furnace control to turn on the blower when energized. However, in this configuration, this (normally) input becomes an *output* to energize the condenser when a cooling call has been sent from the communicating thermostat.

When this configuration is desired, use the wiring diagram in Figure 64 to con-

nect the thermostat and condenser to the furnace control.

NOTE: A heat pump condenser cannot be installed with this configuration. There is no control for the reversing valve.

STARTUP FOR SYSTEMS CONFIGURED WITH COMMUNICATIONS

▲ WARNING

INSTALLATION OF LINE VOLTAGE AND GAS MUST BE PERFORMED ACCORDING TO INSTRUCTIONS WRITTEN IN THIS MANUAL. FAILURE TO DO SO COULD RESULT IN INJURY OR DEATH.

When the furnace is configured for communications, the components on the network (i.e. furnace, thermostat and condenser) must establish communications before engaging a heat (or other) thermostat demand. The procedure for establishing communications is automatic and is described below. Once communications is established, the start-up procedure will be the same as the general start-up instructions described in the section of this manual titled **START-UP PROCEDURES**.

Once the communicating wiring is properly installed and the furnace is connected to line voltage, the system can be turned on. The thermostat will display the following text:

SEARCHING

is displayed several times for several seconds. Next, the text

FURNACE FOUND

and

AIR CONDITIONER FOUND

or

HEAT PUMP FOUND

(depending on which is installed in the system) will be displayed. The process can take several minutes (up to a maximum of 30) to complete. If these messages are not displayed within 30 minutes after energizing the system, communications can not be established. There are many reasons why communications may not be established – including improper settings of the “TERM” and “BIAS” switches (see BIAS / TERMINATION) and improper wiring (see **WIRING A FURNACE FOR COMMUNICATIONS** above).

FIGURE 64

WIRING DIAGRAM – SPECIAL CONFIGURATION: COMMUNICATING THERMOSTAT AND FURNACE WITH NON-COMMUNICATING CONDENSER

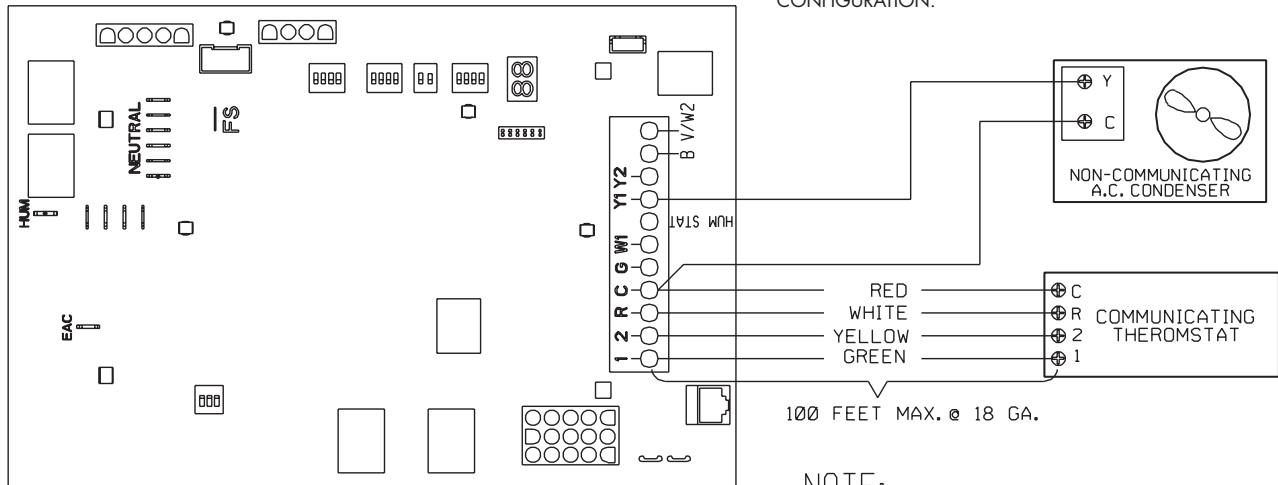

NOTE: DEHUMIDIFICATION FUNCTION FROM A COMMUNICATING THERMOSTAT WILL NOT BE POSSIBLE WITH THIS CONFIGURATION.

NOTE:

THIS CONFIGURATION IS VALID FOR A.C. CONDENSERS ONLY. HEAT PUMP CONDENSERS CAN NOT BE INSTALLED IN THIS CONFIGURATION BECAUSE THERE IS NO CONTROL OUTPUT FOR A REVERSING VALVE AVAILABLE

ST-A1173-01

The order in which these messages will be displayed will depend on which components are energized first. The order listed here assumes that the furnace and condenser are energized at the same time. If not, the order of display will be in the order that the components are turned on.

When the system has found all necessary components, the text area of the communicating thermostat will go blank. This is an indicator that the system is operating properly. Proceed by engaging a typical thermostat call to determine if operation is correct as described in the section of this book titled START UP PROCEDURES to test heating, cooling and fan operation and to make necessary adjustments.

ACTIVE FAULT CODES WITH COMMUNICATING SYSTEMS

Two levels of fault codes exist: (1) Non-critical and (2) Critical. In general a non-critical fault permits all (or nearly all) operations to proceed and a critical fault prevents all (or nearly all) operations from proceeding. Detailed explanations are given for each fault code and how to diagnose and troubleshoot problems by fault code displayed in the "TROUBLESHOOTING" section of this manual.

Active faults of either level will be displayed at the thermostat in the "ACTIVE FAULT" area of the thermostat. To enter the furnace "ACTIVE FAULT" area using a communicating thermostat, see the installation and operation instructions for that thermostat.

For detailed user menu text, navigation and descriptions, refer to the section of this manual titled **COMMUNICATING SYSTEMS** under the subsection titled **USER MENUS**.

Below describes some basic methods for entering and viewing furnace fault messages and user menus for two different communicating thermostats available at the time of publication of this manual. Further setup and installation information on these thermostats can be found in their respective installation and operation instructions.

FIGURE 65

VIEWING DETAILED FAULT MESSAGES ON THE (-)HC-TST501CMMS COMMUNICATING THERMOSTAT

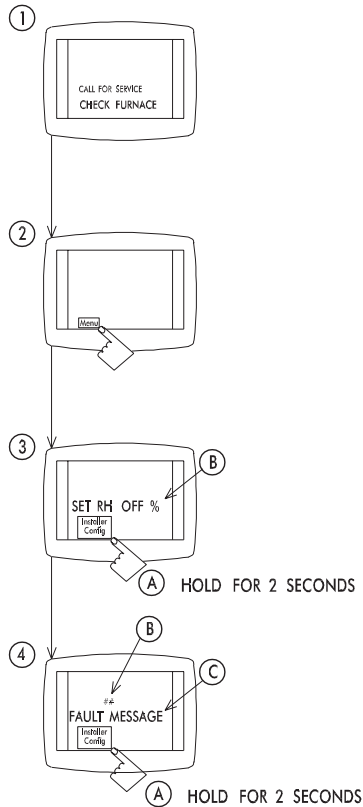

THERE ARE TWO TYPES OF FAULTS THAT CAN BE ACTIVE AT ANY GIVEN TIME

① CRITICAL FAULTS

② NON-CRITICAL FAULTS

CRITICAL FAULTS PREVENT THE FURNACE FROM OPERATING. WHEN THERE IS A CRITICAL FAULT A "CALL FOR SERVICE" ICON WILL BE DISPLAYED AND THE TEXT "CHECK FURNACE" WILL BE DISPLAYED IN THE TEXT AREA.

TO VIEW EITHER FAULT TYPE (CRITICAL OR NON-CRITICAL), FIRST PRESS THE "MENU" BUTTON.

PRESS (AND HOLD DOWN FOR 2 SECONDS) THE "INSTALLER CONFIG" BUTTON (A). THE TEXT "SET RH OFF %" (OR SIMILAR) WILL BE DISPLAYED IN THE TEXT AREA (B).

PRESS (AND HOLD DOWN FOR 2 SECONDS) THE "INSTALLER CONFIG" BUTTON (A) UNTIL A FAULT CODE NUMBER (B) AND MESSAGE (C) IS DISPLAYED.

ST-A1118-01-3

(-)HC-TST501CMMS PROGRAMMABLE COMMUNICATING THERMOSTAT

TIPS FOR NAVIGATING FURNACE USER MENUS USING THE (-)HC-TST501CMMS THERMOSTAT

NOTE: The (-)HC-TST501CMMS thermostat does not have built-in humidification control in heating mode (or any other mode). However, dehumidification is possible in cooling. If humidification control is required, a separate humidistat or a communicating thermostat with humidification capability (such as

(-)HC-TST550CMMS) must be used. (See the section of this manual titled Accessories, Humidification and Dehumidification for wiring of a separate humidistat.)

Viewing the Active Faults: Figure 65 demonstrates how to view the furnace active faults with the (-)HC-TST501CMMS communicating thermostat.

Entering and Viewing the Furnace Main Menu and Sub Menus: Figure 66 demonstrates how to view and enter the furnace user menu and subsequent sub-menus with the (-)HC-TST501CMMS communicating thermostat. To get into the submenus, use the up and down arrow keys of the thermostat to display the desired menu and press the "Installer Config" button on the thermostat to enter that menu.

FIGURE 66

ENTERING FURNACE MAIN MENU ON THE (-)HC-TST501CMMS COMMUNICATING THERMOSTAT

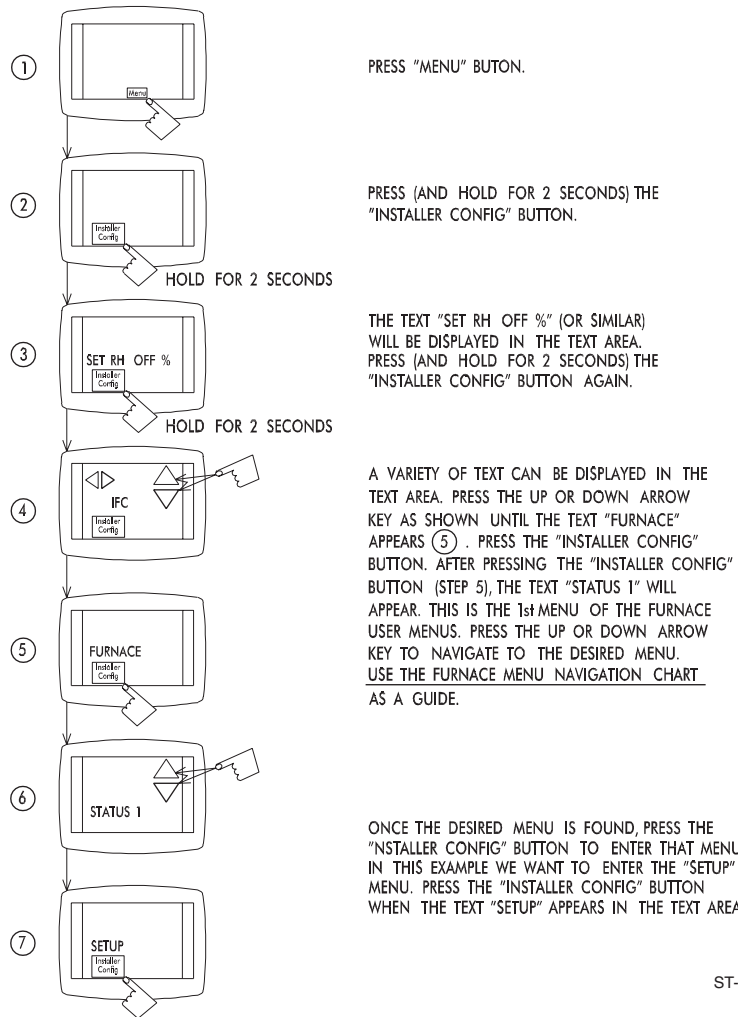

ST-A1118-01-4

Making Setup Changes: Figure 67 demonstrates how to make changes to the SETUP sub-menu with the (-)HC-TST501CMMS communicating thermostat.

FIGURE 67

EXAMPLE – CHANGING ITEMS IN THE “SETUP” MENU OF THE (-)HC_TST50/CMMS COMMUNICATING THERMOSTAT

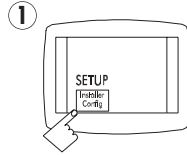

IN THIS EXAMPLE, WE WANT TO CHANGE THE “MAX HEAT ADJUST” TO -15%. FIRST, ENTER THE SETUP MENU AS DESCRIBED IN “ENTERING THE FURNACE MAIN MENU”

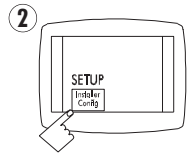

AFTER ENTERING THE “SETUP” MENU OF THE FURNACE (SEE STEP 7 IN FIGURE 66), THERE WILL BE SEVERAL VALUES THAT CAN BE CHANGED BY THE INSTALLER (BASED ON NEEDS OF THE INSTALLATION). THESE VALUES CAN BE CHANGED TO THE DESIRED SETTING BY PRESSING THE LEFT OR RIGHT ARROW KEYS UNTIL THE DESIRED VALUE IS DISPLAYED AND THEN PRESSING EITHER THE UP OR DOWN ARROW KEY OR THE “MENU” KEY. AN EXAMPLE FOLLOWS:

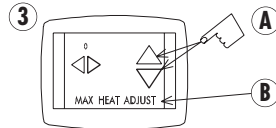

PRESS THE UP OR DOWN ARROW KEY (A) UNTIL THE TEXT “MAX HEAT ADJUST” IS DISPLAYED (B).

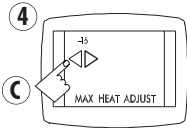

THE TEXT “0” IS DISPLAYED IN THE UPPER LEFT-HAND CORNER OF THE THERMOSTAT. PRESS THE LEFT OR RIGHT ARROW KEY A UNTIL THE TEXT “-15” IS DISPLAYED IN THE CORNER (C).

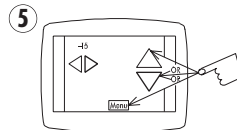

PRESS THE UP OR DOWN ARROW KEY OR THE “MENU” KEY TO SET THE VALUE. IF THE “MENU” KEY IS PRESSED, THE PREVIOUS MENU SCREEN WILL BE SHOWN – BUT, THE NEW VALUE (-15) WILL BE SET.

ST-A1118-01-2

Escaping or Returning from Menus:

Figure 68 demonstrates how to escape from a menu back to the main screen or how to return to a previous menu level using the (-)HC-TST501CMMS communicating thermostat.

FIGURE 68

ESCAPING OR RETURNING FROM MENUS IN THE (-)HC-TST501CMMS COMMUNICATING THERMOSTAT

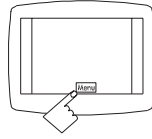

ONCE A MENU ITEM IS SELECTED, YOU CAN RETURN TO THE PREVIOUS LEVEL BY PRESSING THE "MENU" BUTTON. THIS BUTTON IS USEFUL WHENEVER IT IS NECESSARY TO GO BACK TO THE PREVIOUS MENU FROM ANY MENU.

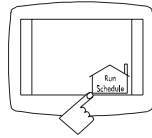

TO RETURN TO THE MAIN SCREEN (TOP LEVEL WITH TEMPERATURE AND SETPOINT DISPLAYED) YOU CAN ALWAYS EITHER PUSH THE "RUN SCHEDULE" BUTTON (TEXT INSIDE HOUSE ICON) OR WAIT A FEW MINUTES AND THE THERMOSTAT WILL AUTOMATICALLY RETURN TO THE TOP SCREEN AFTER A TIMEOUT PERIOD.

ST-A1118-01-1

(-)HC-TST550CMMS FULL COLOR, PROGRAMMABLE COMMUNICATING THERMOSTAT

TIPS FOR NAVIGATING FURNACE USER MENUS USING THE (-)HC-TST550CMMS THERMOSTAT

Viewing Furnace Fault Messages with the (-)HC-TST550CMMS Thermostat

To enter a particular user menu on the (-)HC-TST550CMMS, full color communicating thermostat follow the directions below.

FIGURE 69
ENTER THE *ADVANCED INSTALLER MENU*



1. From the main screen, press the left and right arrow keys together at the same time for at least 3 seconds. The next screen below will appear. (Note that Call for Service appears at the bottom of the screen. This is an indicator that the fault messages should be viewed to determine the cause of the fault.)

FIGURE 70
SELECT *FAULT STATUS*

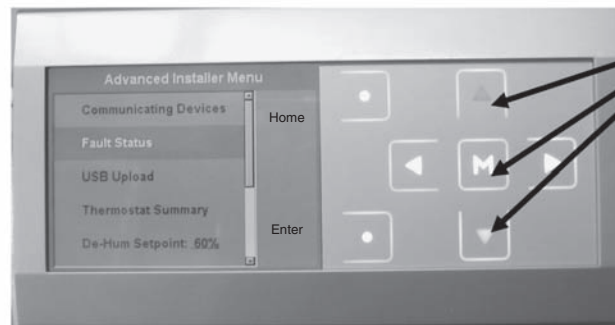

2. The ***ADVANCED INSTALLER MENU*** is displayed. Use the up and down arrow keys to highlight ***Fault Status***. Next, press the "***M***" key. The next screen below will appear

FIGURE 71
FAULT MESSAGE (IF ANY) (*MAIN LIMIT OPEN*) DISPLAYED.

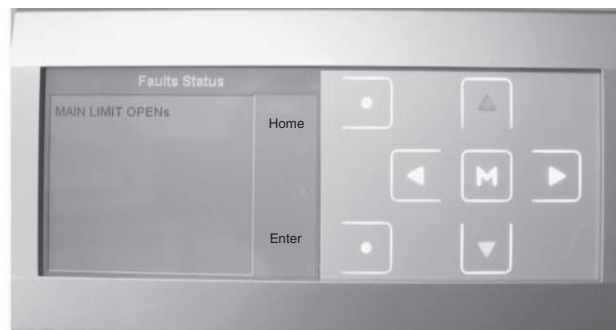

3. The ***Fault Status*** screen will appear with a description of the current fault (if any). Use the section of this manual titled ***FURNACE FAULT CODES EXPANDED WITH DESCRIPTIONS AND SOLUTIONS*** for a full explanation of the fault and possible solution(s). To escape from this menu, press the ***Enter*** (to return to the furnace user menus) or ***Home*** button or just wait a few minutes and the main screen will appear again.

VIEWING FURNACE USER MENUS WITH THE (-)HC-TST550CMMS THERMOSTAT

To enter a particular user menu on the (-)HC-TST550CMMS, full color communicating thermostat follow the directions below.

Use the section of this manual titled **Communicating Systems** under the sub-section titled **User Menus** to navigate through the user menus.

FIGURE 72
ENTER THE **ADVANCED INSTALLER MENU**.



1. From the main screen, press the left and right arrow keys together at the same time for at least 3 seconds. The next screen below will appear.

FIGURE 73
NAVIGATING TO **COMMUNICATING DEVICES** AND SELECT.



2. The **ADVANCED INSTALLER MENU** is displayed. Use the up and down arrow keys to highlight **Communicating Devices**. Next, press the "M" key. The next screen below will appear.

FIGURE 74
NAVIGATE TO **FURNACE** AND SELECT.



3. From the devices listed, use the up and down arrow keys to highlight the selection titled **Furnace**. Next, Press the "M" Key. The next screen below will appear.

FIGURE 75
NAVIGATE TO DESIRED USER MENU AND SELECT.



4. The furnace menu options will appear. Use the up and down arrow keys to select the desired menu. Next, press "M" to enter the desired menu. Next, the next screen below will appear.

FIGURE 76
NAVIGATE THE USER MENUS USING UP AND DOWN ARROW KEYS.



5. Use the up and down arrow keys to view the menu items.
6. To escape from this menu, press the **Enter** (to return to the furnace user menus) or **Home** button or just wait a few minutes and the main screen will appear again.

CHANGING FURNACE SETUP ITEMS ON THE (-)HC-TST550CMMS THERMOSTAT

To change a particular furnace user setup item on the (-)HC-TST550CMMS, full color communicating thermostat follow the directions below.

Use the section of this manual titled **Communicating Systems** under the sub-section titled **User Menus** to navigate through the setup user menus.

FIGURE 77
ENTER THE **ADVANCED INSTALLER MENU**.



1. From the main screen, press the left and right arrow keys together at the same time for at least 3 seconds. The next screen below will appear.

FIGURE 78
IN THE **ADVANCED INSTALLER MENU** SELECT **COMMUNICATING DEVICES**.



2. The **ADVANCED INSTALLER MENU** is displayed. Use the up and down arrow keys to highlight **Communicating Devices**. Next, press the "M" key. The next screen below will appear.

FIGURE 79
SELECT **FURNACE** FROM THE LIST OF **COMMUNICATING DEVICES**.



3. From the devices listed, use the up and down arrow keys to highlight the selection titled **Furnace**. Next, Press the "M" Key. The next screen below will appear.

FIGURE 80
SELECT **SETUP** FROM THE LIST OF **FURNACE** MENUS.



4. The furnace menu options will appear. Use the up and down arrow keys to navigate to the **SETUP** menu. Press "M" to enter the menu. Next, the next screen below will appear.

FIGURE 81
SELECT THE SETUP ITEM TO BE ADJUSTED (*MAX HEAT ADJ%*)



5. Use the up and down arrow keys to view and navigate to the desired setup menu item. Once the desired menu item is highlighted, press the "**M**" key to enter the sub menu. In this example, we will change the **MAX HEAT Adj%** (currently set to 0%)

FIGURE 82
SELECT THE DESIRED VALUE (7)

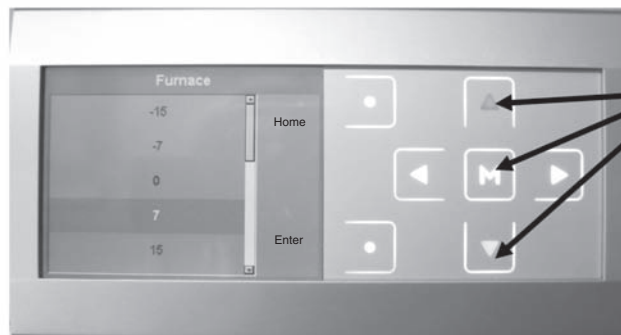

6. Use the up and down arrow keys to view and navigate to the desired setup selection. Once the desired menu item is highlighted, press the "**M**" key to change the selection. In this example, we will change the **MAX HEAT Adj%** (currently set to 0%) to **+7%**

FIGURE 83
UPDATING THE SUBSYSTEM

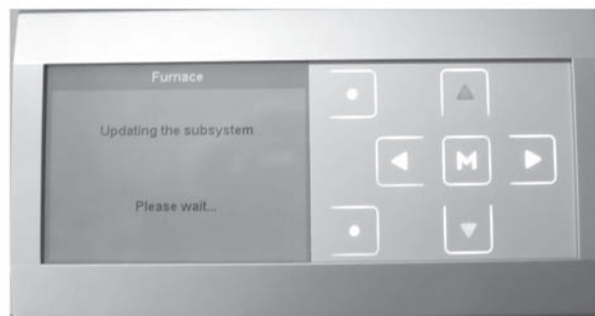

7. This screen; **Updating the Subsystem** will be displayed briefly while the system updates the setting.

FIGURE 84
UPDATE SUCCESSFUL



8. This screen; **Update Successful** will be displayed briefly upon successfully changing the setting.
9. To escape from this menu, press the **Enter** (to return to the furnace user menus) or **Home** button or just wait a few minutes and the main screen will appear again.