



GRANT^{UK}

Part No. DOC 16 Rev. 09 December 2004

USER and INSTALLATION
INSTRUCTIONS

OUTDOOR MODULES

50/70, 70/90, 90/120 & 110/140

For use with Kerosene or Gas Oil

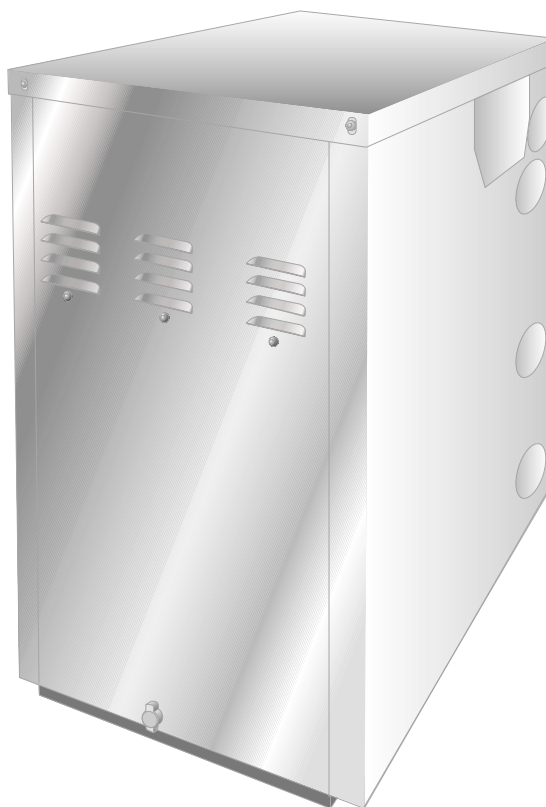

After installing the boiler leave these instructions with the User

This appliance is deemed a controlled service and specific regional statutory requirements may be applicable



LIST OF CONTENTS

Section	Subject	Page
1	User instructions	3
2	Technical information	6
3	General boiler information	10
4	Boiler installation	18
5	Commissioning	29
6	Information for the user	31
7	Boiler servicing	31
8	Wiring diagrams	35
9	Fault finding	39
10	Boiler spares	41
11	Burner spares	42
12	Health and safety information	43
13	EC declaration of conformity	44

COMMISSIONING REPORT

Date:

Commissioning engineer: Tel. No:

Boiler model/output: kW Fuel type: Kerosene or Gas oil

Nozzle size: Pump pressure: Air setting:

Flue gas % CO₂: Net flue gas temp: Smoke No:

SERVICE LOG

It is recommended that the boiler should be regularly serviced, at least once a year, and the details entered below by the service engineer.

Date	% CO ₂	Net flue gas temp.	Smoke No.	Service engineer/Tel. No.



1.1 About your boiler

The boiler will provide domestic hot water and central heating and is fully automatic once switched on. An illuminated On/Off switch, see Fig. A, is fitted to the Outdoor modules, which lights when the boiler is switched on, but does not necessarily indicate the burner is firing.

1.2 Boiler controls (see Fig. A)

To access the Outdoor module controls, remove the front panel by turning the handle and withdrawing it forwards at the bottom.

1.3 Lighting your boiler (see Fig. A)

- 1 Ensure that** - There is sufficient fuel, of the correct type, in the supply tank and all fuel supply valves are open. The water supply is on. The electricity supply to the boiler is off. The Boiler On/Off switch is set to off (the neon in the switch is not alight). The Test switch is set to Off. The room thermostat (if fitted) is at the desired setting. The boiler thermostat is set to the required setting.
 - Switch on the electricity supply to the boiler.
 - Set the Boiler On/Off switch to on. A neon in the switch lights when it is in the on position.
- The boiler will now light automatically.

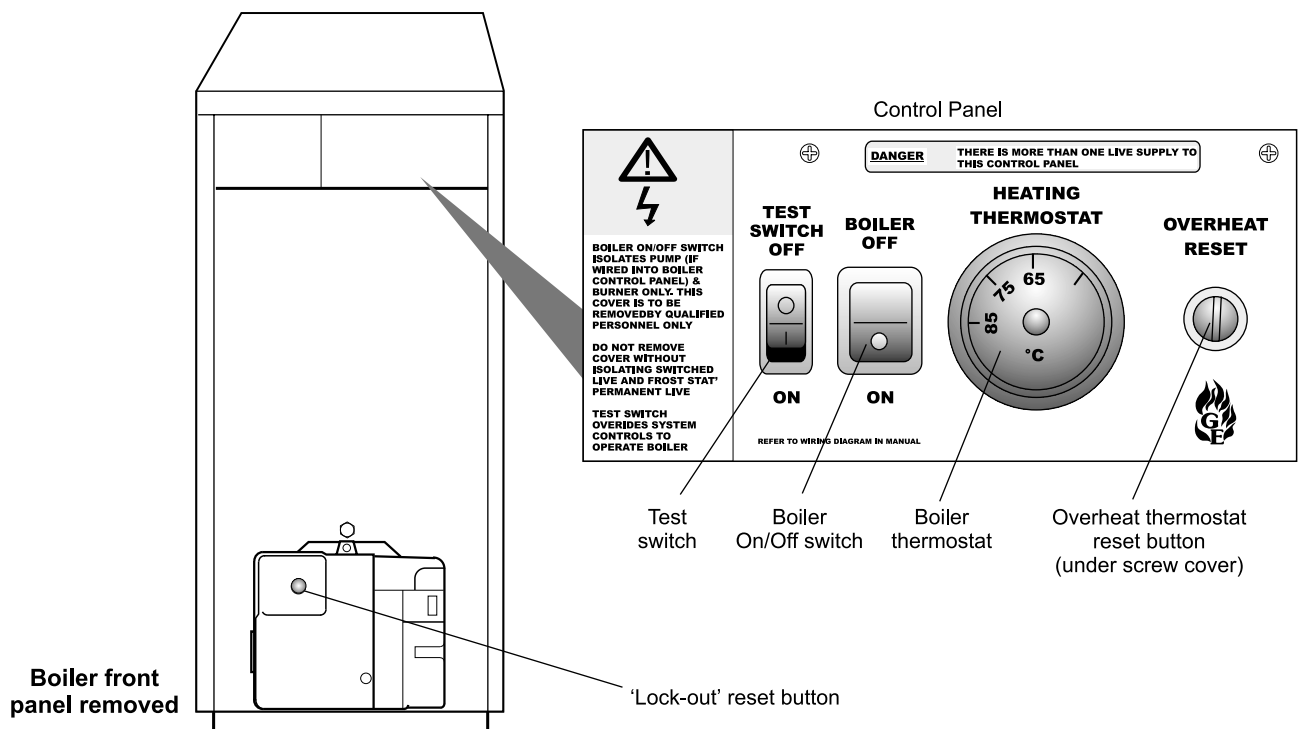

Controls for Outdoor modules - Fig. A



1 - USER INSTRUCTIONS

1.4 Turning off your boiler (see Fig. A)

Outdoor modules for short periods - Set the boiler switch to OFF.

To restart, set the switch to ON.

Outdoor modules for long periods - Set the boiler switch to OFF. If required, the fuel supply valve may be closed and the water and electricity supplies turned off at the mains.

Note: If the electricity, fuel and water supplies are turned off, the built-in frost thermostat will **not** operate.

1.5 Points to check if burner fails to light

- 1 Check that the boiler switch is ON.
- 2 Check that any remote programmer (if fitted) is working and is in an 'on' period.
- 3 Check that all thermostats are set to the desired setting and are calling for heat.
- 4 Check if the burner 'Lock-out' reset button is lit. If it is, press it to start the burner. If the burner fails to light and goes to 'Lock-out' again, check that you have sufficient fuel in the storage tank and that the fuel supply valve is open.
- 5 Ensure that a fuse has not blown or that the electricity supply has not failed.
- 6 Check to see if the safety thermostat has operated (see section 1.7).

If the burner still fails to light after carrying out these checks then a fault exists. Switch off the electricity supply to the boiler and contact your Service engineer.

1.6 About your fuel

The Outdoor modules will operate on either Class C2 Kerosene or Class D Gas Oil (conventional flue only). Your Installer will have informed you of the type of fuel your boiler has been set to use and he will have marked this on the boiler data label. You should always quote the type of fuel you require when ordering from your supplier.

Do not wait until the fuel runs out before you order some more. Sludge in the bottom of the tank may be drawn into the fuel lines. If it is possible, switch off the boiler when the new supply is delivered and leave the fuel to settle for an hour before restarting the boiler.

1.7 General notes and care of your system

- 1 **Boiler thermostat** - This control allows the temperature of the water leaving the boiler to heat the radiators and domestic hot water to be adjusted.

Note: If you have a cylinder thermostat on your hot water cylinder, this will control the temperature of your domestic hot water. The boiler thermostat setting must be equal to or above the cylinder thermostat setting to enable the cylinder thermostat to control the domestic hot water system.

The boiler thermostat has an operating range of 65 to 85°C. The following settings are recommended:-

- a Heating and hot water in Winter 85°C
 - b Hot water only in Summer 65°C
- 2 **Burner Lock-out reset button** - If there is a burner malfunction, a built-in safety circuit switches the burner off and the Lock-out reset button will light. Usually such malfunctions are short lived and pressing the reset button will restore normal operation.

If the burner continually goes to 'Lock-out' a fault exists **or** the fuel supply is low. If you have sufficient fuel, you will need to call your Service engineer.
 - 3 **Safety thermostat** - Your boiler is fitted with a safety overheat thermostat which will automatically switch off the boiler in the case of a control malfunction causing overheating.

If your boiler goes off and you try to light it but nothing happens and the 'Lock-out' reset button on the burner is not lit, the overheat thermostat has probably operated. The boiler will not light until the thermostat is reset. To reset, unscrew the small plastic cap (see Fig. A), press the button then replace the cap.

If this condition continually repeats, contact your Service engineer.

- 4 **Ventilation** - Always ensure that the boiler has adequate ventilation. Any ventilation openings **must not** be obstructed. Periodically check that they are clear.

Do not attempt to 'box in' the boiler or build a compartment around.

Do not place any combustible material around or on the boiler or flue pipe.

Do not place anything against the door of the Outdoor modules that might obstruct the ventilation openings.



- 5 Flue terminal** - The flue terminal **must not** be obstructed or damaged.

In severe conditions check that the terminal does not become blocked by snow.

- 6 Frost protection** - Your Installer may have fitted a frost thermostat. If not, and you are likely to be away for a short time, leave the boiler on with the boiler thermostat set at a low setting. For longer periods the boiler and system should be drained. Contact your Service engineer for draining and filling the system.

The control panel of the Outdoor modules includes a built-in frost thermostat factory set to 5°C.

Note: For Outdoor modules we recommend that a combined antifreeze and corrosion inhibitor be used in the primary water system.

- 7 Cleaning and servicing** - Lightly wipe over the case with a damp cloth and a little detergent. **Do not** use abrasive pads or cleaners.

You should have your boiler serviced at least once a year to ensure safe and efficient operation.

Contact your Service engineer for further details.

Warning note - External equipment operated at 230 volts should not be serviced or repaired under adverse weather conditions.

- 8 Failure of electricity supply** - If the electricity supply fails, the boiler will not operate. It should relight automatically when the supply is restored.

1.8 Electricity supply

The boiler requires a 230/240 V ~ 50 Hz supply. It must be protected by a 5 Amp fuse.

Warning: This appliance must be earthed.

1.9 Sealed central heating system

If your boiler is operating on a sealed heating system, the installer will have pressurised the system and should have told you (or set it on the pressure gauge) the system pressure when cold (this is normally between 0.8 and 1.0 bar, which will increase slightly when hot). If the pressure (when cold) is below the set pressure mentioned above, you should contact your Installer or Service engineer to re-pressurise the system. If the system requires frequent re-pressuring, ask your Installer or Service engineer to check the heating system for leaks.

The boiler or system will be fitted with an automatic air vent to remove air from the system. Any air trapped in the radiators should be removed by venting the radiators using the vent screw at the top of each radiator. Only vent a radiator if the top is cool and the bottom is hot. Excessive venting will reduce the system pressure, so only vent when necessary and check the system pressure as mentioned above. Re-pressurise the system if necessary.

Note: Your system may incorporate a 'Top-Up' vessel, advice on how to use it should be obtained from your installer.

The boiler or system will be fitted with a safety valve to release excess pressure from the system. If water or steam is emitted from the end of the safety valve discharge pipe, switch off the boiler and contact your Installer or Service engineer.

The expansion vessel air charge must be checked annually. Failure to maintain an adequate air charge in the vessel may invalidate the warranty.



2 - BOILER TECHNICAL INFORMATION

2.1 Boiler technical data

Model		50/70	70/90	90/120	110/140
Water content	litre	14	21	22	26
	gal	3.1	4.6	4.6	5.7
* Weight (dry)	kg	94.3	129.7	138	167
	lb	208	286	304	368
Max. heat input (Kerosene)	kW	22.0	28.3	38.0	43.7
	Btu/h	75 000	96 560	129 600	149 140
Flow and return connections		3 x 1" BSP		3 x 1 ¹ / ₄ " BSP	4 x 1 ¹ / ₄ " BSP
Sealed system kit connection		1 x 3 ³ / ₄ " BSP		1 x 3 ³ / ₄ " BSP	2 x 1 ¹ / ₂ " BSP
Waterside resistance					
Flow/Return temp. difference of 10°C		26.5 mbar			37.5 mbar
Flow/Return temp. difference of 20°C		9.5 mbar			6.1 mbar
Maximum static head		28 m			
Minimum circulating head		1m			
Boiler thermostat range		65 to 85°C			
Limit (safety) thermostat switch off temp.		111°C ± 3°C			
Max. hearth temperature		Less than 50°C			
Electricity supply		230/240 V ~ 50 Hz Fused at 5 Amp			
Motor power		90 W max.			
Starting current		2.6 Amp			
Running current		0.85 Amp			
Oil connection		1/4" BSP Male (on end of flexible fuel line)			
Max. operating press.	Sealed system	2.5 bar			
	Open system	3 bar			

* Weight includes burner

Sealed system versions

Expansion vessel size	10 litre (50/70, 70/90) - pre charged at 1.0 bar
	12 litre (90/120, 110/140) - pre charged at 1.0 bar
Maximum heating system volume	75 litres (50/70, 70/90)
	90 litres (90/120, 110/140)
Pressure relief valve	2.5 bar
Maximum heating system pressure (cold)	1.0 bar
Minimum heating system pressure (cold)	0.5 bar



2.2 Outdoor Modules using Class C2 kerosene

Note: All boilers are despatched for use with kerosene.

Model (Btu/h)	Heat Output		Net eff ** (%)	Net Heat Input		Nozzle	Oil press. (bar)	Smoke No.	Burner head	Fuel flow rate (kg/h)	Flue gas temp. (°C)	CO ₂ (%)
	(kW)	(Btu/h)		(kW)	(Btu/h)							
50/70	14.7	50 000	93.0	16.1	54 900	0.50/60°EH	7.00	0 - 1	LD2SX short	1.33	211	11.5
	*17.6	60 000	93.0	19.3	65 900	0.60/60°EH	7.00	0 - 1	LD2SX short	1.60	211	11.5
	20.5	70 000	93.0	22.5	76 900	0.60/60°EH	8.50	0 - 1	LD2SX short	1.87	211	11.5
70/90	20.5	70 000	93.2	22.5	76 900	0.60/60°EH	8.50	0 - 1	LD3	1.87	180	11.5
	*23.5	80 000	93.2	25.8	87 900	0.75/60°EH	7.00	0 - 1	LD3	2.13	180	11.5
	26.4	90 000	93.2	29.0	98 900	0.75/60°EH	9.50	0 - 1	LD3	2.40	180	11.5
90/120	26.4	90 000	92.0	28.7	96 700	0.75/80°EH	9.50	0 - 1	LD3A	2.38	190	12.0
	*32.2	110 000	92.0	35.0	119 400	1.00/80°EH	8.00	0 - 1	LD3A	2.62	220	12.0
	35.2	120 000	92.0	38.0	129 600	1.00/80°EH	8.60	0 - 1	LD3A	3.12	225	12.0
110/140	32.2	110 000	94.5	34.1	116 450	1.00/60°ES	8.00	0 - 1	LD3A	3.18	180	12.0
	*36.7	125 000	94.1	38.9	132 800	1.10/80°EH	8.50	0 - 1	LD3A	3.24	185	12.0
	41.0	140 000	93.8	43.7	149 140	1.25/60°S	8.25	0 - 1	LD3A	3.80	184	12.0

2.3 Outdoor Modules using Class D gas oil - Conventional flue only

Model	Heat Output		Net eff ** (%)	Net Heat Input		Nozzle	Oil press. (bar)	Smoke No.	Burner head	Fuel flow rate (kg/h)	Flue gas temp. (°C)	CO ₂ (%)
	(kW)	(Btu/h)		(kW)	(Btu/h)							
50/70	20.5	70 000	93.0	22.5	76 900	0.40/60°S	12.00	0 - 1	LD2SX short	1.60	200	11.5
70/90	26.4	90 000	93.2	29.0	98 900	0.60/60°S	12.00	0 - 1	LD3	1.97	200	11.5
90/120	35.2	120 000	92.0	38.2	130 400	0.75/80°S	12.50	0 - 1	LD3A	3.20	220	12.0
110/140	41.0	140 000	94.3	43.5	148 470	1.00/60°S	9.80	0 - 1	LD3A	2.97	184	12.0

Notes:

- 1 The data given above is approximate only.
- 2 The above settings may have to be adjusted on site for the correct operation of the burner.
- 3 Gas Oil is **not** suitable for use with the low level discharge of the Outdoor modules.
- 4 The installer **must** amend the boiler data label if the type of fuel or nozzle used is changed.
- 5 When commissioning, or when the output is changed, the air damper must be adjusted to obtain the correct CO₂ level.
- 6 Net flue gas temperatures given are ± 10%.
- 7 * Indicates the factory set output.
- 8 ** Net thermal efficiency (BSRIA).

To obtain the correct CO₂ level, the final flue gas reading must be taken with all casing and door panels fitted.

**Gas Oil may only be used for conventional flue or discharge 2 m above ground level.
Kerosene may be used for any application.**



2.4 Boiler dimensions

50/70 Outdoor module

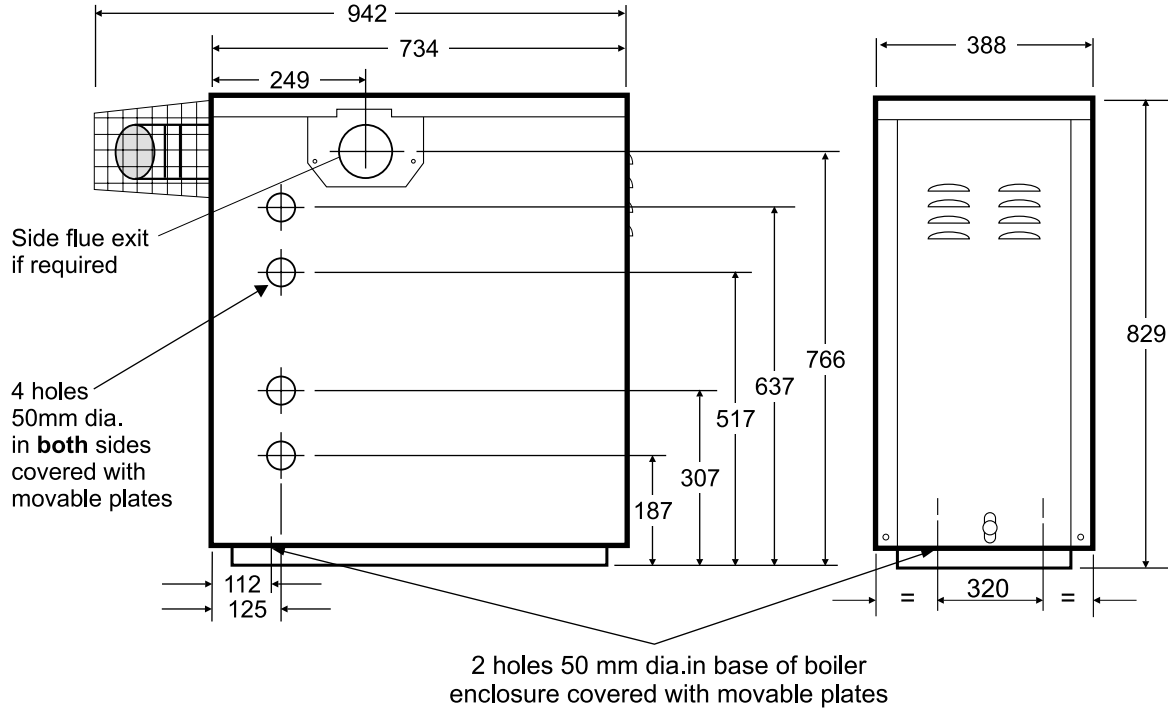

Fig. 1a - 50/70 Dimensions

70/90 and 90/120 Outdoor module

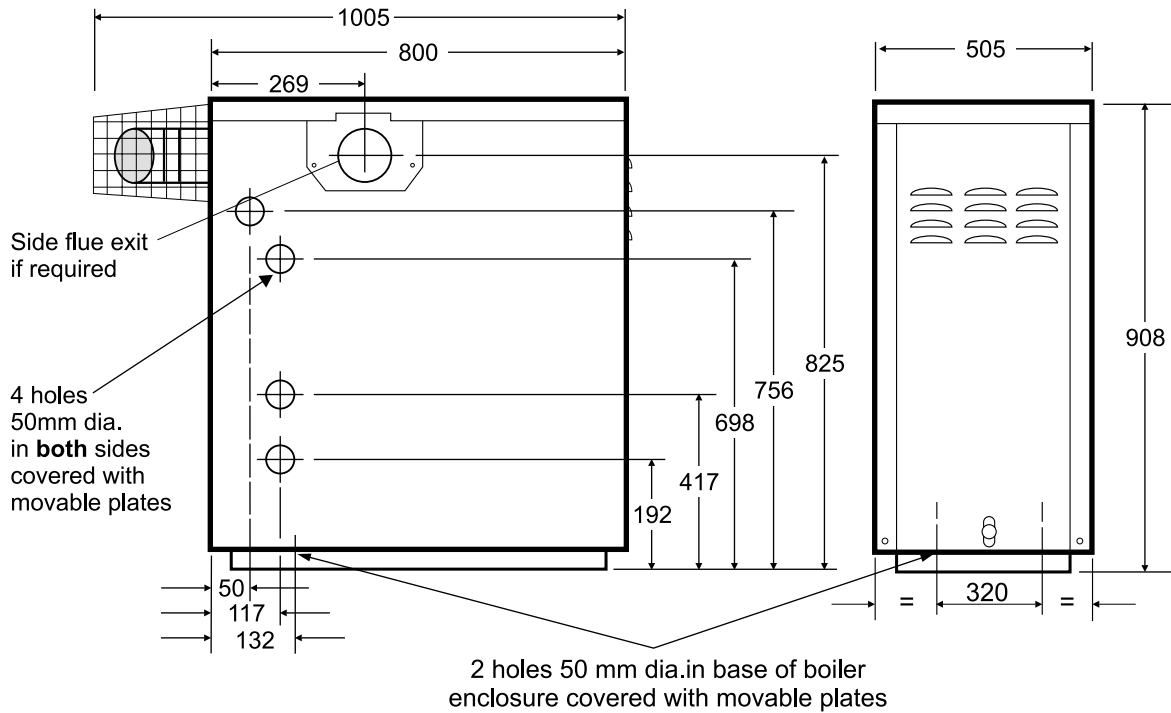

Fig. 1b - 70/90 and 90/120 Dimensions



110/140 Outdoor module

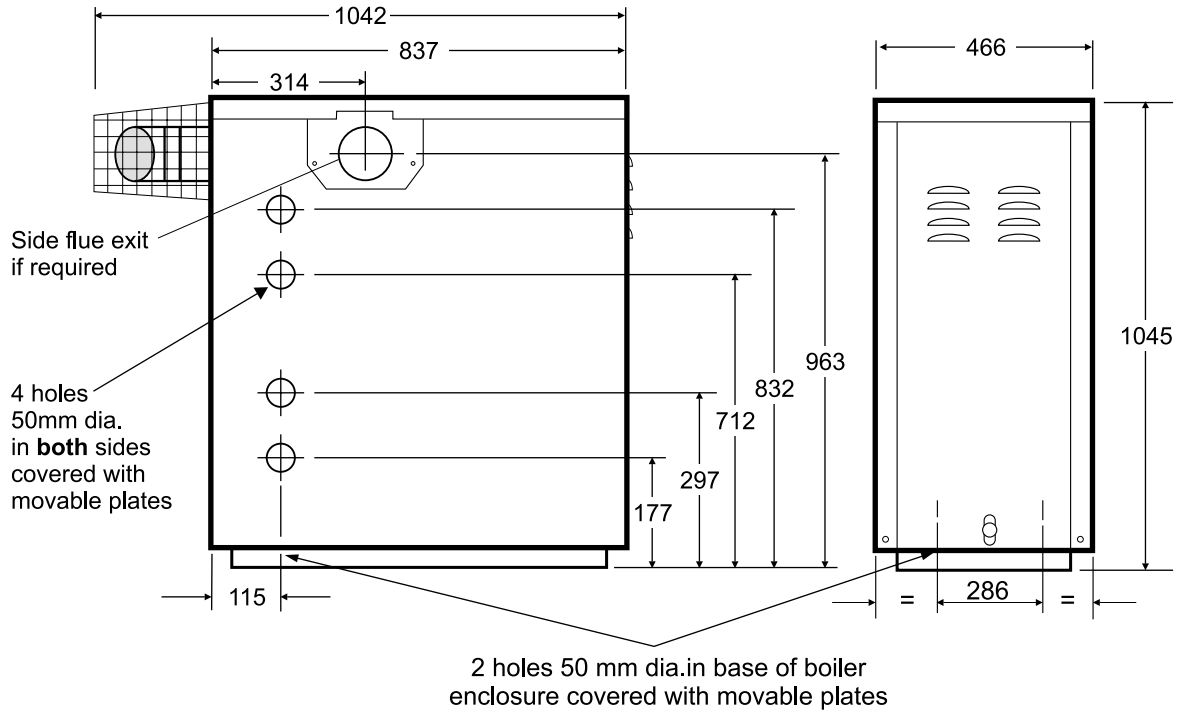

Fig. 1c - 110/140 Dimensions



3.1 Boiler description

The Outdoor Modules have an insulated weatherproof enclosure made of galvanised steel with a powder coated finish, and are designed for external installation, either against a wall or free standing some distance away from the property, as required.

The Outdoor modules are part of the Grant range of automatic pressure jet oil boilers designed for use with a fully pumped central heating system, or gravity primary system, providing hot water via an indirect hot water cylinder. They are not suitable for use with either a direct cylinder or 'primatic' cylinder.

The boilers are suitable for use on a sealed heating system, and a sealed system kit, including circulating pump, is available (see section 4.5), if required.

The factory fitted low level discharge flue system can be adjusted on site for either rear, left hand or right hand flue outlet position, as required.

The installation should also be in accordance with the latest edition of the following British Standard Codes of Practice:-

BS 715	Metal flue pipes, fittings, terminals and accessories.
BS 799:5	Oil storage tanks.
BS 1181	Clay flue linings and flue terminals.
BS 4543:3	Factory made insulated chimneys for oil fired appliances.
BS 4876	Performance requirements for oil burning appliances.
BS 5410:1	Code of Practice for oil firing appliances.
BS 5449	Forced circulation hot water systems.
BS 7593	Code of Practice for treatment of water in heating systems.
BS 7671	Requirements for electrical installations, IEE Wiring Regulations.

Failure to install and commission appliances correctly may invalidate the boiler warranty.

3.2 Regulations to comply with

Installation of all Outdoor Modules must be in accordance with the following recommendations:-

- Building Regulations for England and Wales, and the Building Standards for Scotland issued by the Department of the Environment and any local Byelaws etc.
- Model and local Water Undertaking Byelaws.
- Applicable Control of Pollution Regulations.
- The following OFTEC requirements:-
 - OFS T100 Polythene oil storage tanks for distillate fuels.
 - OFS T200 Fuel oil storage tanks and tank bunds for use with distillate fuels, lubrication oils and waste oils.

Further information may be obtained from the OFTEC Technical Information Book 3 (Installation requirements for oil fired boilers and oil storage tanks).

Regional statutory requirements may deem this appliance to be a 'controlled service'. Where this is the case, it is a legal requirement that the appliance is installed and commissioned either under the remit of building control or by a 'Competent person' such as a suitably qualified Oftec registered technician.



3.3 Fuel supply

3.3.1 Fuel storage

The tank should be positioned in accordance with the recommendations given in BS 5410:1:1997, which gives details of filling, maintenance and protection from fire.

A galvanised tank must not be used.

A plastic tank may be used and must comply with OFS T100.

Note: Plastic tanks should be adequately and uniformly supported on a smooth level surface, across their entire base area.

3.3.2 Fuel pipes

1 Fuel supply pipes should be of copper tubing with an internal diameter of at least 8 mm. Galvanised pipe must not be used.

2 Flexible pipes must not be used outside the boiler case.

3 A remote sensing fire valve must be installed in the fuel supply line 1 metre from the point of entry to the boiler, with the sensing head located above the burner using the clip mounted on the underside of the control panel. Recommendations are given in BS 5410:1:1997.

4 A metal bowl type filter with a replaceable micronic filter must be fitted in the fuel supply line. A shut-off valve should be fitted before the filter, to allow the filter to be serviced.

5 A flexible fuel line, adaptor and $\frac{1}{4}$ " BSP isolation valve are supplied loose with the boiler for the final connection to the burner. If a two pipe system or Tiger Loop system is used, an additional flexible fuel line (600 mm) and $\frac{3}{8}$ " to $\frac{1}{4}$ " BSP male adaptor are available from Grant Engineering (UK) Limited.

6 Flexible fuel lines should be inspected annually when the boiler is serviced and replaced every two years.

3.3.3 Single pipe system - (See Fig. 2)

1 Where the storage tank outlet is above the burner the single pipe system should be used. The height of the tank above the burner limits the length of pipe run from the tank to the burner.

2 As supplied the burner is suitable for a single pipe system.

3.3.4 Two pipe system - (See Fig. 3)

1 When the storage tank outlet is below the burner, the two pipe system should be used. The pipe runs should be as shown in Fig. 3. The return pipe should be at the same level in the tank as the supply pipe, both being 75 to 100 mm above the base of the tank. The pipe ends should be a sufficient distance apart so as to prevent any sediment disturbed by the return entering the supply pipe.

2 Avoid the bottom of the tank being more than 3 m below the burner.

3 A non-return valve should be fitted in the supply pipe together with the filter and fire valve. The return pipe must be unrestricted.

4 To be used with a two-pipe system, the burner **must** be fitted with an additional flexible fuel line (a flexible fuel line (600 mm) and $\frac{3}{8}$ " to $\frac{1}{4}$ " BSP male adaptor are available from Grant Engineering (UK) Limited). See section 3.3.6.

5 The pump vacuum should not exceed 0.4 bar. Beyond this limit gas is released from the oil.

A by-pass plug is supplied with the boiler and must be fitted for two-pipe operation. See section 3.3.6.

For guidance on installation of top outlet fuel tanks and suction oil supply sizing, see OFTEC booklet T1/139. Available at www.oftec.org.uk



3 - GENERAL BOILER INFORMATION

Head A (m)	Maximum pipe run (m)	
	8 mm ID pipe	10 mm ID pipe
0.5	10	20
1.0	20	40
1.5	40	80
2.0	60	100

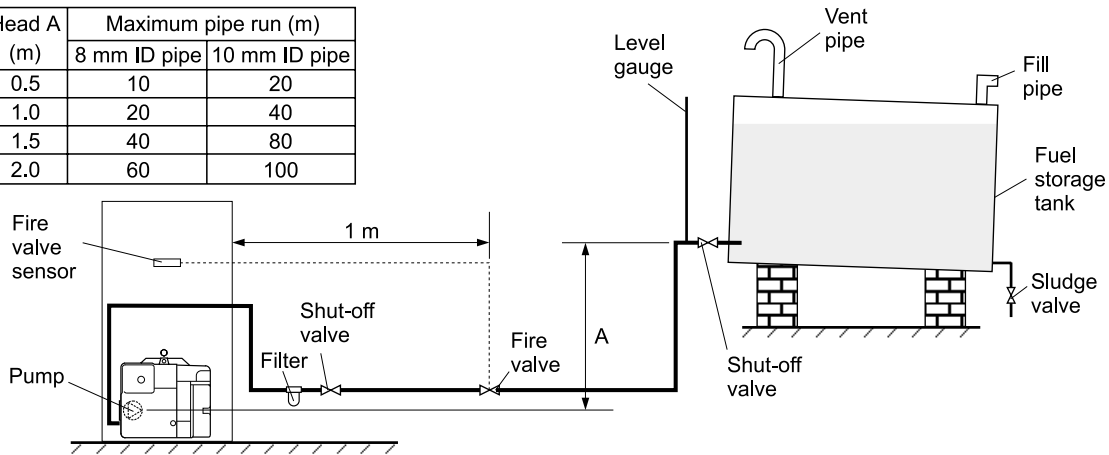

Fig. 2 - Single pipe system

Head A (m)	Maximum pipe run (m)	
	8 mm ID pipe	10 mm ID pipe
0	35	100
0.5	30	100
1.0	25	100
1.5	20	90
2.0	15	70
3.0	8	30
3.5	6	20

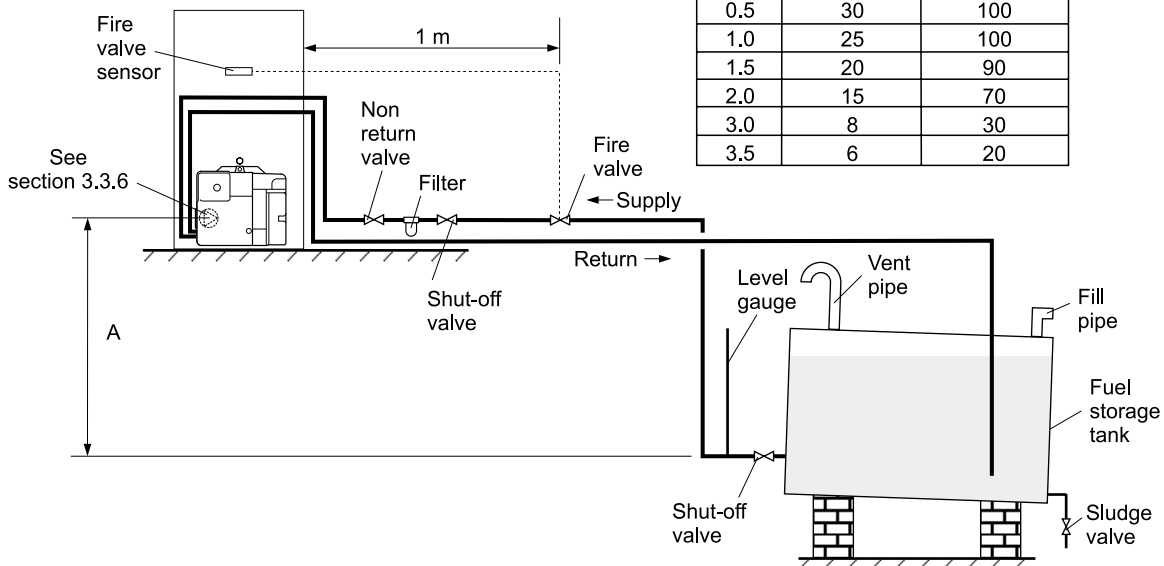

Fig. 3 - Two pipe system

3.3.5 Tiger Loop system - (See Figs. 4, 5)

- 1 When The storage tank is below the burner, an alternative to a two pipe system can be achieved using the Tiger Loop oil deaerator. This effectively removes the air from the oil supply on a single pipe lift.
- 2 The Tiger Loop is connected close to the boiler as a two pipe system (omitting the non-return valve) as shown in Fig. 4.
Refer to the manufacturers instructions supplied with the Tiger Loop. The Tiger Loop **must** be mounted vertically.

- 3 To be used with a Tiger Loop system, the burner **must** be fitted with an additional flexible fuel line (a flexible fuel line (600 mm) and $\frac{3}{8}$ " to $\frac{1}{4}$ " BSP male adaptor are available from Grant Engineering (UK) Limited). See section 3.3.6.

A by-pass plug is supplied with the boiler and must be fitted for two-pipe operation. See section 3.3.6.

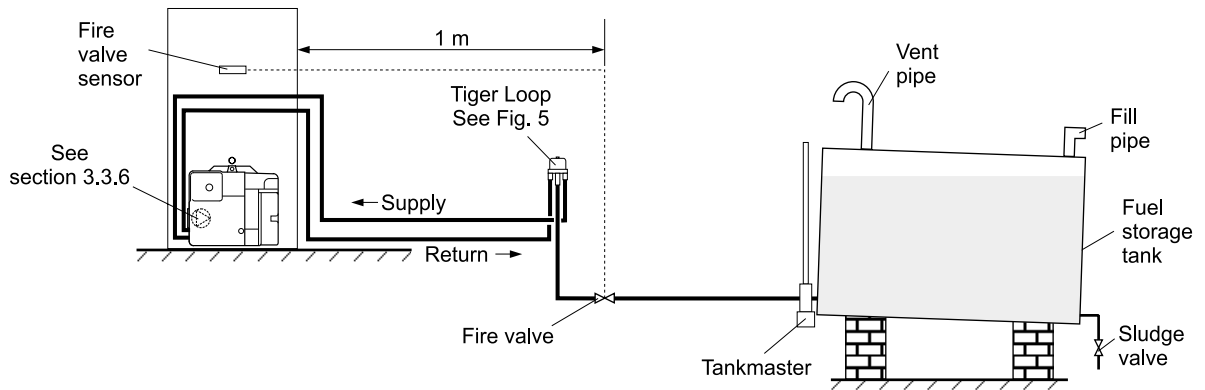

Fig. 4 - Tiger loop system

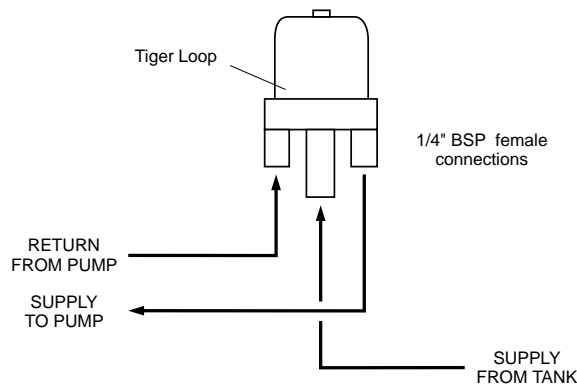

Fig. 5 - Tiger loop

3.3.6 Two pipe oil supplies - (See Fig. 6)

- 1 The fuel pump is supplied for use with a single pipe fuel supply system. For use on a two pipe system, it is necessary to fit the By-pass screw (see Fig. 6) into the tapping in the return port.
- 2 The By-pass screw is supplied in the boiler accessory pack.
- 3 Remove the plastic burner cover (two screws).
- 4 Remove and discard the blanking plug from the return connection of the pump and fit the By-pass screw using an hexagonal key.
- 5 Connect the return oil flexible fuel line to the pump.
- 6 Connect the 3/8" to 1/4" BSP adaptor to the flexible fuel line.

7 Flexible fuel lines and adaptors are available from Grant Engineering (UK) Ltd.

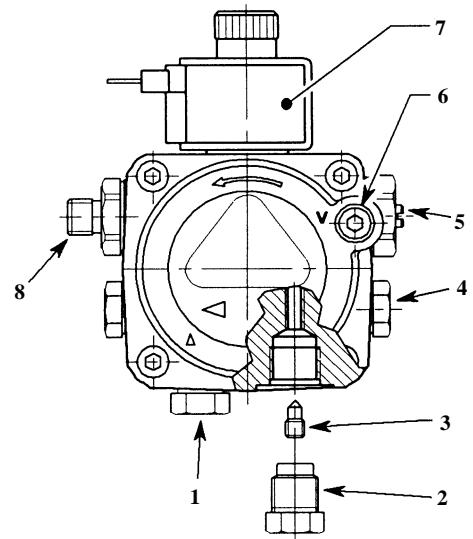

Fig. 6 - RDB pump

- | | |
|-----------------------------|---------------------------|
| 1 Oil inlet connection | 5 Pressure adjuster |
| 2 Return connection | 6 Vacuum gauge connection |
| 3 By-pass screw | 7 Solenoid |
| 4 Pressure gauge connection | 8 Supply to nozzle |



3 - GENERAL BOILER INFORMATION

3.4 Electricity supply

- 1 A 230/240 V ~ 50 Hz mains supply is required.
The boiler must be earthed.
- 2 The electrical supply to the boiler **and** control system should be fed from a single separate 5 Amp circuit breaker with earth leakage protection, providing complete electrical isolation.
- 3 A fused double pole switch or a fused three pin plug and shuttered outlet socket should be used for the connection.
- 4 The power supply cable should be at least 0.75 mm² PVC as specified in BS 6500, Table 16.
- 5 All the wiring external to the boiler must be in accordance with the current I.E.E. Wiring Regulations.
- 6 Any room thermostat or frost thermostat used must be suitable for use on mains voltage.
- 7 The boiler requires a permanent mains supply, do not interrupt it with any external time control.
- 8 In the event of an electrical fault after installation of the boiler, the following electrical system checks must be carried out:- Short circuit, Polarity, Earth continuity and Resistance to earth.

3.5 Frost protection

- 1 Outdoor Modules are supplied with a factory fitted frost protection thermostat, located inside the boiler control panel. This is pre-wired to the boiler electrical system and factory set to 5°C.
- 2 For total system protection against freezing, particularly during extended periods without electrical power, Grant recommend the use of a combined heating system antifreeze and corrosion inhibitor, used in accordance with the manufacturer's instructions.

3.6 Boiler location

- 1 The Outdoor Module must stand on a solid, level surface capable of supporting the weight of the boiler when full of water, e.g. a prepared concrete standing, paving slabs bedded down on sand/cement, or similar.
- 2 The Module can be installed either against the building or 'free standing' some distance away from the building.
- 3 The Module must be positioned such that the required clearances from the low level flue outlet, as shown in Fig. 7, are achieved.
- 4 Adequate clearance must be left around the Module for servicing. In particular, a minimum clearance of 600 mm above the Module for removal of the top panel and 600 mm at the opposite end to the flue outlet for access to the burner.
- 5 The flue terminal must be a minimum distance of 1.8 m from an oil storage tank.

The flue terminal should be positioned so as to avoid products of combustion accumulating in stagnant pockets around the building or entering into buildings.



3.7 Flue terminal locations

The minimum dimensions for positioning the flue terminal are shown in Fig. 7.

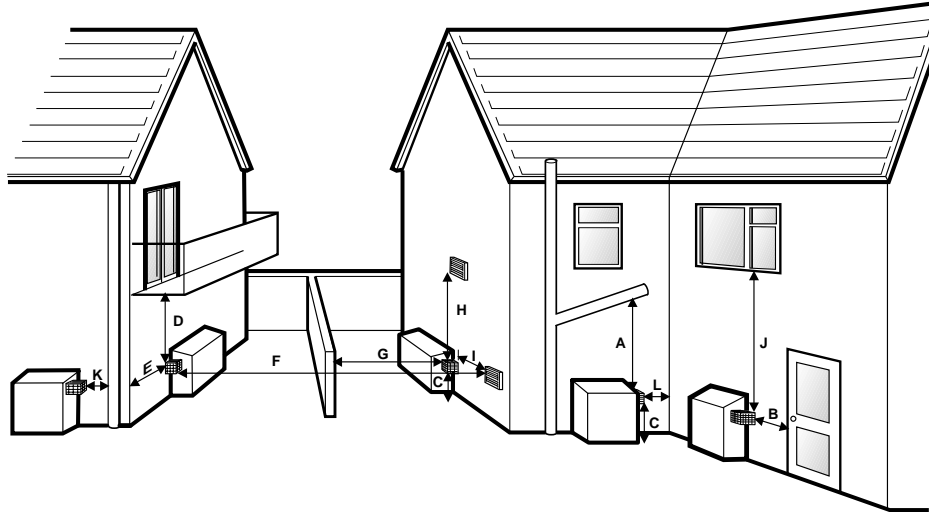

Fig. 7 - Flue terminal positions

Terminal position	Min. distance
A Below gutters, eaves or balconies (with protection)	*600
B Horizontally from a door, window or air vent	600
C Above ground, flat roof or balcony level	**300
D Below gutters, eaves or balconies (without protection)	*600
E From an external corner	300
F From a terminal facing the terminal	1200
G From a surface facing the terminal	600
H Vertically from a terminal on the same wall	1500
I Horizontally from a terminal on the same wall	750
J Directly below an opening, air brick, window, etc.	600
K From a vertical drain pipe or soil pipe	300
L From an internal corner	300

Notes: * 75 mm with protection.
** 300 mm British Standards.

Distances measured to rim of terminal.

Clearances recommended by Grant Engineering (UK) Limited in accordance with British Standards and Building Regulations.

- Notes:**
- 1 An opening means an openable element, such as an openable window, or a permanent opening such as a permanently open air vent.
 - 2 Notwithstanding the dimensions given, a terminal should be at least 300 mm from combustible material, e.g. a window frame.
 - 3 A way of providing protection of combustible material would be to fit a heat shield at least 750 mm wide.

3.8 Pipework materials

General - Grant boilers are compatible with both copper and plastic pipe. Where plastic pipe is used it must be of an oxygen barrier type. The first metre of pipe connected to the boiler must be made in copper.

Sealed systems - Where a sealed heating system is fitted to the boiler only copper tube may be used.

Underfloor systems - Plastic pipe may be used on underfloor systems where the plastic pipe is fitted after the thermostatic mixing valve. Copper tube must be used for the primary pipework between the boiler and the underfloor mixing/blending valves.



3.9 Water connections

- 1 Pipework connections are provided on the rear of the boiler (i.e. inside the enclosure on the opposite side of the boiler to the burner). These connections are accessed by removing the back panel of the enclosure, below the low level flue outlet. See Fig. 14 or 14a for details of the different connection arrangements.
- 2 The flow and return pipework can exit the boiler enclosure either through the openings provided in both sides (under the movable cover plates) and through the wall when installed against the building, or down and through the openings provided in the base of the enclosure for 'free standing' installations.
- 3 There is sufficient space adjacent to the connections, in the rear of the enclosure, to accommodate the circulating pump, if required.
- 4 All water connections have been temporarily sealed with plastic caps to prevent any residual water (from factory pressure testing) leaking from the boiler during storage and transit. **All** the caps must be removed before connecting any fittings.
Plug all unused connections.
- 5 Fit drain cocks in the central heating and domestic hot water systems to allow the complete system to be fully drained.
- 6 Thoroughly flush the system before fitting the circulating pump.

50/70 and 70/90 models

- 1 One high level flow and two low level return 1" BSP connections are provided on the rear of the boiler (see Fig. 14). A 1" BSP plug is supplied for the second return connection, if not used.

90/120 model

- 1 One high level flow and two low level return 1¼" BSP connections are provided on the rear of the boiler. A 1¼" BSP plug is supplied for the second return connection if not used.

50/70, 70/90 and 90/120 models

- 2 A ¾" BSP tapping is provided at the front of the boiler, above the burner, for the connection of the Grant Outdoor Module sealed system kit, if required (see section 4.5). If no sealed system kit is fitted, plug the unused connection using a ¾" BSP plug (not supplied).

110/140 model

- 1 Two high level flow and two low level return 1¼" BSP connections are provided on the rear of the boiler (see Fig. 14a). Two 1¼" BSP plugs are provided for any unused connections. A ½" BSP tapping is provided on the top of the boiler for the connection of a sealed system kit. The kit may be fitted to either the left or right hand side of the boiler depending upon the location of the thermostat pocket. (Please read the following notes).
- 2 Flow and return connections should be diagonally opposed if possible. The pipework connections **can** be taken from the same side, but the thermostat pocket and phials **must** be located on the same side as the connections.

Note: The 110/140 model has two tappings (½" BSP) on the top of the boiler for the thermostat pocket supplied with the boiler. Fit the thermostat pocket to the boiler and insert the two thermostat phials into the pocket. If a sealed system kit is not being fitted, the spare ½" tapping should be plugged using the ½" BSP plug supplied.

- 3 If required, a sealed system kit is available from Grant Engineering (UK) Ltd. See section 4.5.
- 4 A ½" BSP tapping is provided at the bottom right hand corner of the boiler to allow the fitting of the drain cock supplied.
Plug all unused connections.

3.10 Heating system diagrams

See Figs. 8, 9 and 10

3.10.1 Sealed system - (See Fig. 8)

Refer to section 4.5 for details of fitting the Grant sealed system kit.

- 1 The boiler is only suitable for use with a sealed system complying with the requirements of BS 5449. The maximum temperature of the central heating water is 85°C.
- 2 The system must be provided with the following items:-
 - a Diaphragm expansion vessel complying with BS 4814.
 - b Pressure gauge.
 - c Safety valve.
 - d Approved method for filling the system.Refer to BS 7074:1 for further guidance.

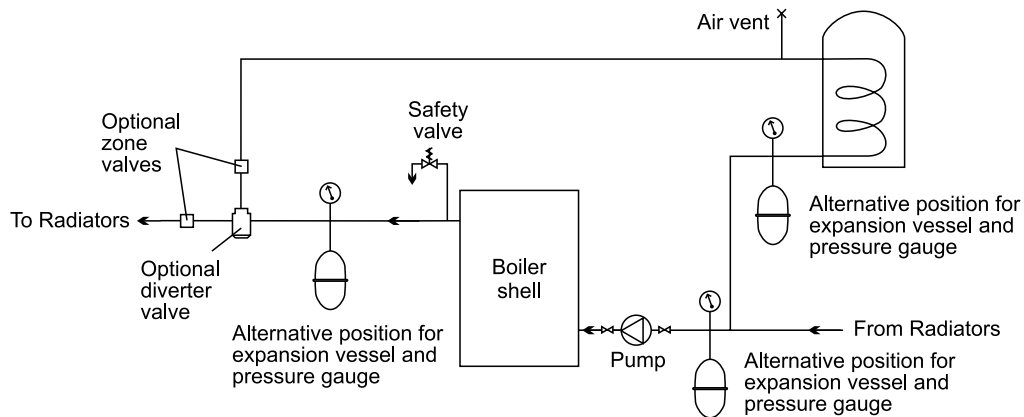

Fig. 8

3.10.2 Gravity domestic hot water - (See Fig. 9)

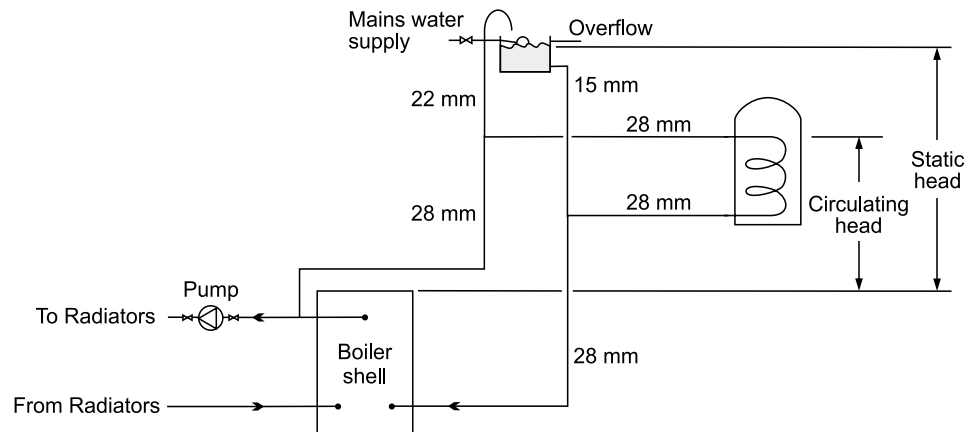

Fig. 9 - 50/70, 70/90 and 90/120 connections shown

- 3 The expansion vessel can be fitted in either the return or flow pipework in any of the recommended positions as shown in Fig. 8. To reduce the operating temperature of the expansion vessel diaphragm, position it below the pipe to which it is connected. The expansion vessel may be positioned away from the system, providing the connecting pipe is not less than 13 mm diameter. Refer to section 4.8 for further details of the expansion vessel.
- 4 The pressure gauge should have an operating range of 0 to 4 bar.
- 5 The safety valve, set to operate at 2.5 bar (max.), should be fitted in the flow pipework near to the boiler. The pipework between the safety valve and boiler must be unrestricted, i.e. no valves. The safety valve should be connected to a discharge pipe which will allow the discharge to be seen, but cannot cause injury to persons or property.
- 6 Provision should be made to replace water lost from the system. This may be done manually (where allowed by the local Water Undertaking) using a filling loop arrangement.
- 7 An automatic air vent should be fitted to the highest point of the system.
- 8 For proprietary expansion vessel/valve/gauge packs, refer to the manufacturers instructions for the correct location on the heating system.
- 9 All fittings used in the system must be able to withstand pressures up to 2.5 bar.
- 10 Radiator valves must comply with the requirements of BS 2767(10):1972.
- 11 One or more drain taps (to BS 2879) must be used to allow the system to be completely drained.



3 - GENERAL BOILER INFORMATION

3.10.3 Fully pumped - (See Fig. 10)

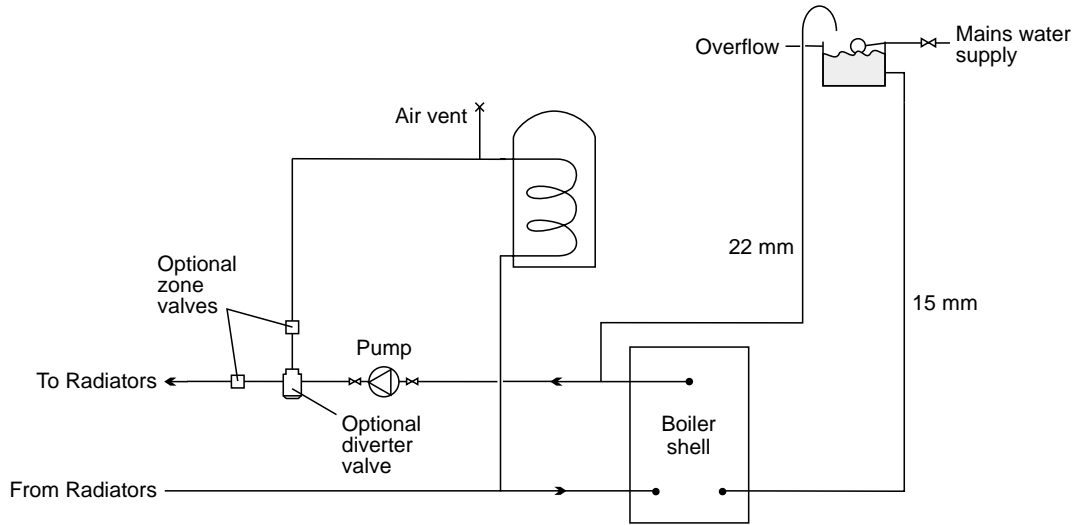

Fig. 10 - 50/70, 70/90 and 90/120 connections shown

To avoid the danger of dirt and foreign matter entering the boiler the complete heating system should be thoroughly flushed out - before the boiler is connected and then again after the system has been heated and is still hot. This is especially important where the boiler is used on an old system.

For optimum performance after installation, this boiler and its associated central heating system must be flushed in accordance with the guidelines given in BS 7593:1992 'Treatment of water in domestic hot water central heating systems'.

This must involve the use of a proprietary cleaner, such as BetzDearborn's Sentinel X300 or X400, or Fernox Superfloc. Full instructions are supplied with the products, but for immediate information, please contact BetzDearborn on 0151 4209563 or Fernox on 0179 9550811.

For Long term protection against corrosion and scale, after flushing, it is recommended that an inhibitor such as Betzdearborn's Sentinel X100 or Fernox MB1 is dosed in accordance with the guidelines given in BS 7593:1992.

Failure to implement the guidelines may invalidate the warranty.

3.11.4 Underfloor heating system - (See Fig. 11)

On underfloor systems it is essential that the return is pre-heated by mixing flow water into the return before it enters the boiler. The return temperature **must be** maintained above 55°C to prevent internal corrosion of the boiler water jacket.

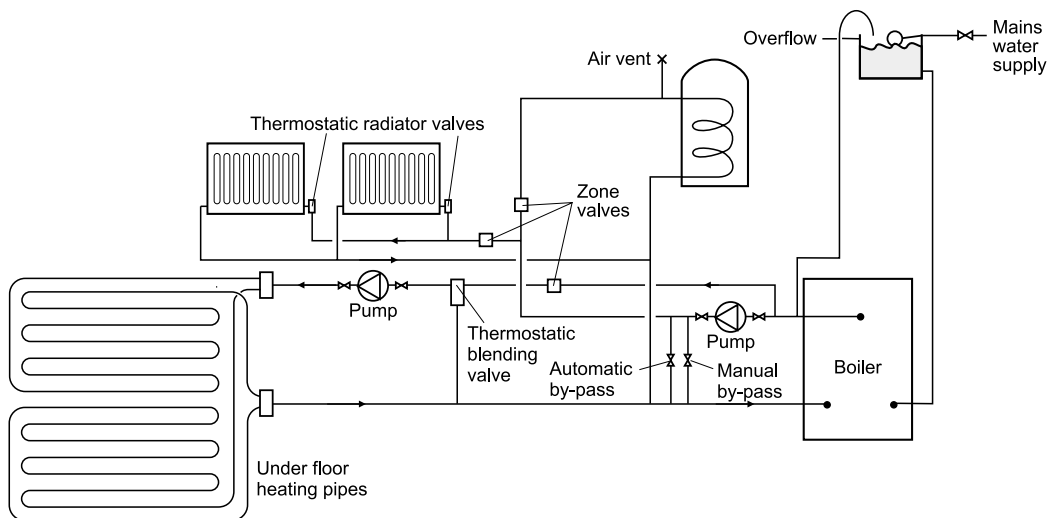

Fig. 11



4.1 Unpack the boiler

- 1 Carefully remove the packaging from the boiler and lift it off the pallet.
- 2 The flue terminal guard is supplied loose inside the packaging.
- 3 Remove the case top panel (four screws).
- 4 The flue may exit the casing from the left, right or rear of the casing. The casing has two removable blanking panels and a flue exit panel. Fit the panel with the flue exit hole and seal in the required position.
- 5 Slacken the wing nuts holding the flue elbow and rotate the elbow to the required direction for the flue to exit the casing.
- 6 Push the end of the flue terminal section with the red seal through the seal in the casing. The terminal has been factory lubricated. Take care not to dislodge or damage the red seals.
- 7 Carefully insert the terminal into the flue elbow until the bend of the terminal contacts the outer casing, then, pull the terminal forward approximately 25 mm and rotate the bend so that the outlet is **horizontal**.

Rear Exit - The flue must discharge away from the building.

Side Exit - The flue should discharge towards the rear of the casing to prevent flue gases re-entering the boiler casing through the air inlet vents on the casing front door.

The flue terminal must be fitted horizontally to prevent dripping from the end of the terminal.

- 8 Tighten the wing nuts holding the flue elbow and fit the stainless steel flue guard using the two screws provided.
- 9 The top panel of the casing has been designed so that it may be fitted to create a slight slope away from the side positioned against the wall. To tilt the top panel, loosen the four top panel casing screws, one at each corner and push down on the side furthest from the wall. Tighten the screws. See Fig. 12.

4.2 Preparations for installation

- 1 If the boiler is to be fitted against the wall, prepare the wall to accept the heating system pipework. To mark the wall for drilling, refer to Fig. 1 for the positions of the pipework openings in the enclosure sides.

Note: Pipework should be insulated where it passes through the wall into the boiler enclosure.

If the boiler is to be installed 'free standing' (i.e. away from a wall) and the pipework run underground, slide away the covers to open the two pipe openings in the base of the boiler enclosure. Using a sharp knife, cut through the polystyrene in the base, around the edge of the holes, to allow the flow and return pipes to enter the enclosure.

- 2 The electrical supply to the boiler should be routed through the wall in a suitable conduit, such that it enters the boiler enclosure via one of the unused pipework openings. The cable can be routed to the front of the boiler, for connection to the boiler control panel, either over the top or beneath the boiler heat exchanger. Heat resistant PVC cable, of at least 1.0 mm² cross section should be used within the boiler enclosure.

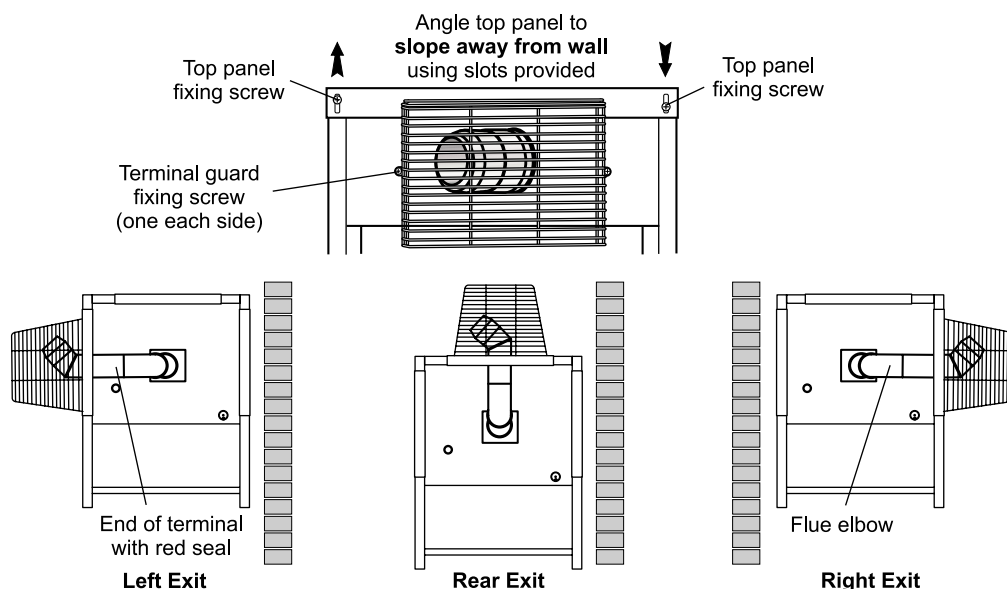

Fig. 12



- 3 The oil supply line should be installed up to the position of the boiler. Refer to section 3.3.2 for details. The final connection into the boiler enclosure can be made with 10 mm soft copper, routed along the base of the enclosure (either between the enclosure and wall or in front of the enclosure) to enter through one of the holes located in the bottom edge side panel, at the front (burner) end.

4.3 Conventional flue

Where it is not practical to use the factory supplied low level flue, the Grant range of Outdoor Modules may be fitted with a conventional flue system.

A twin wall stainless steel insulated flue system is available from Grant UK.

An insulated boiler connector elbow, complete with test point, replaces the low level terminal and flue guard supplied with the boiler.

The Grant External flue system connects to the elbow and may terminate at high level or vertically as required. See Fig. 13.

The flue system is suitable for use with class C2 kerosene and class D gas oil.

When using gas oil the flue must terminate a minimum of 2 metres above outside ground level.

The following components are available from Grant UK.

50/70 and 70/90 Modules	
Item	Part No.
Starter elbow	GKM90
150 mm extension	GX150/90
250 mm extension	GX250/90
450 mm extension	GX450/90
950 mm extension	GX950/90
195-270 mm adjustable extension	GXA250/90
45° elbow	GE45/90
High level terminal	GTH90
Vertical terminal	GTV90
wall bracket	GWB90
Extended wall bracket kit	GEB90

90/120 and 110/140 Modules	
Item	Part No.
Starter elbow	GKM200
150 mm extension	GX150/200
250 mm extension	GX250/200
450 mm extension	GX450/200
950 mm extension	GX950/200
195-270 mm adjustable extension	GXA250/200
45° elbow	GE45/200
High level terminal	GTH200
Vertical terminal	GTV200
wall bracket	GWB200
Extended wall bracket kit	GEB200

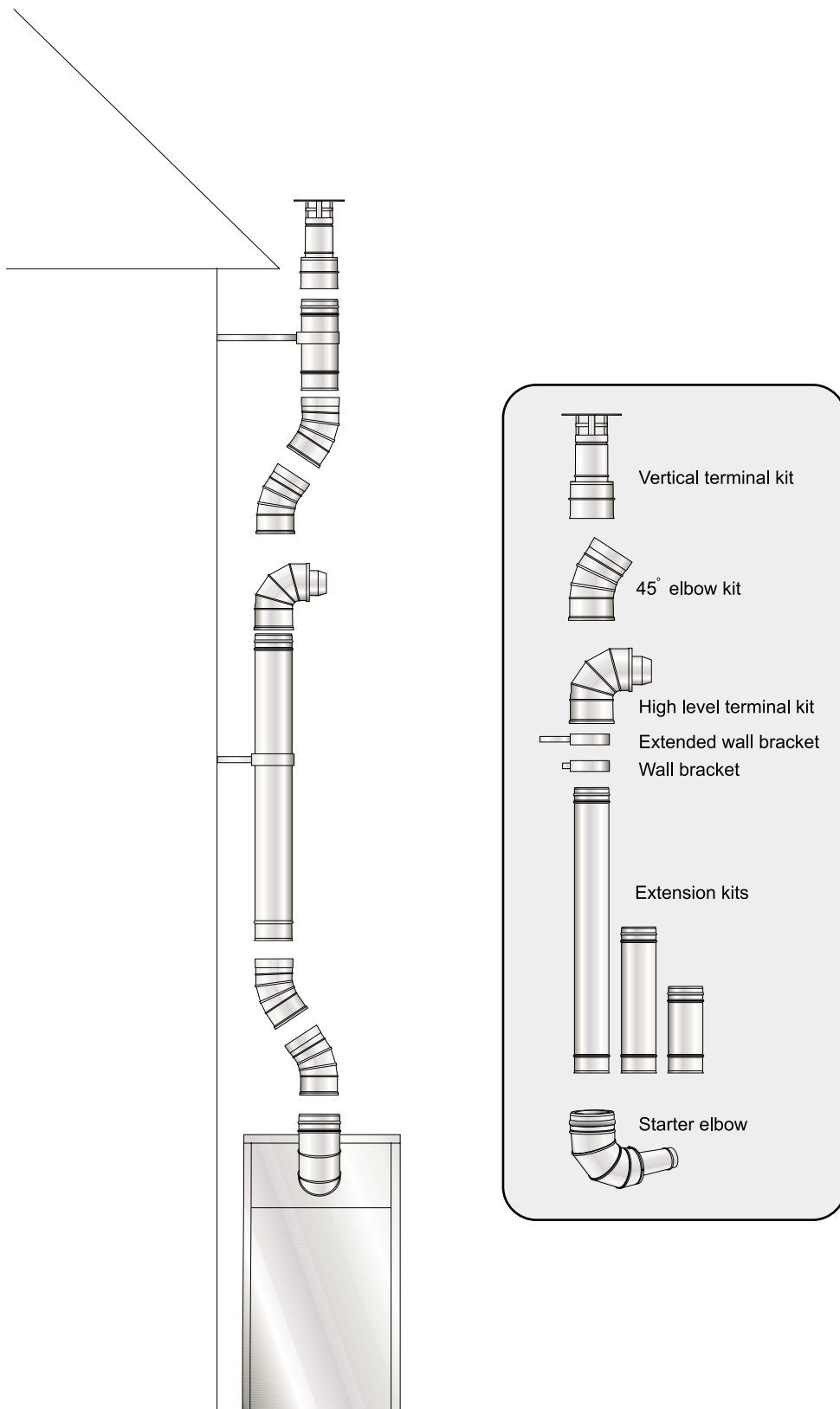

Fig. 13



4 - BOILER INSTALLATION

4.4 Make the water connections

See Fig. 14 or 14a

- 1 To gain access to the water connections, remove the two screws securing the bottom of the back panel and remove it by withdrawing it forwards at the bottom.
- 2 To gain access to the burner, remove the front panel by turning the handle and withdrawing it forwards at the bottom.
- 3 If required, fit the Grant sealed system kit, see section 4.5.
- 4 If no sealed system kit is fitted - Plug the $\frac{3}{4}$ " BSP connection on the front of the boiler, above the burner (50/70, 70/90 and 90/120 only). Fit bent or straight pipe connectors to the flow and return connections, as required, before positioning the boiler if access will be restricted. Fit the thermostat phial pocket (110/140 only) to one of the $\frac{1}{2}$ " BSP connections on top of the boiler (if both flow and return connections are taken from the same side of the boiler, the thermostat phial pocket should be located on the same side as the pipe connections). Plug the remaining $\frac{1}{2}$ " BSP connection using the plug supplied.

- 5 Ensure all plastic caps have been removed from the boiler connections and plug all unused connections.
- 6 Carefully manoeuvre the boiler in position to line up with pipework through the wall. Complete the water connections.

Note: Check that the baffles are in position and that the cleaning cover is correctly fitted and a good seal made.

- 7 If the boiler is installed against a wall, fit the wall flashing strip. Position the strip with the bottom edge of the wider flange 20 mm above the enclosure top panel, with the narrow flange (with the three fixing holes) flat against the wall. The strip should overhang the top panel by an equal amount at each end. Mark the position of the three fixing holes onto the wall, drill and plug the wall and secure the strip with suitable screws (not supplied).
- 8 Fill and vent the water system and check for leaks, rectifying where necessary.

If the Grant sealed system kit is fitted, refer to section 4.8 for details on filling and venting the sealed heating system.

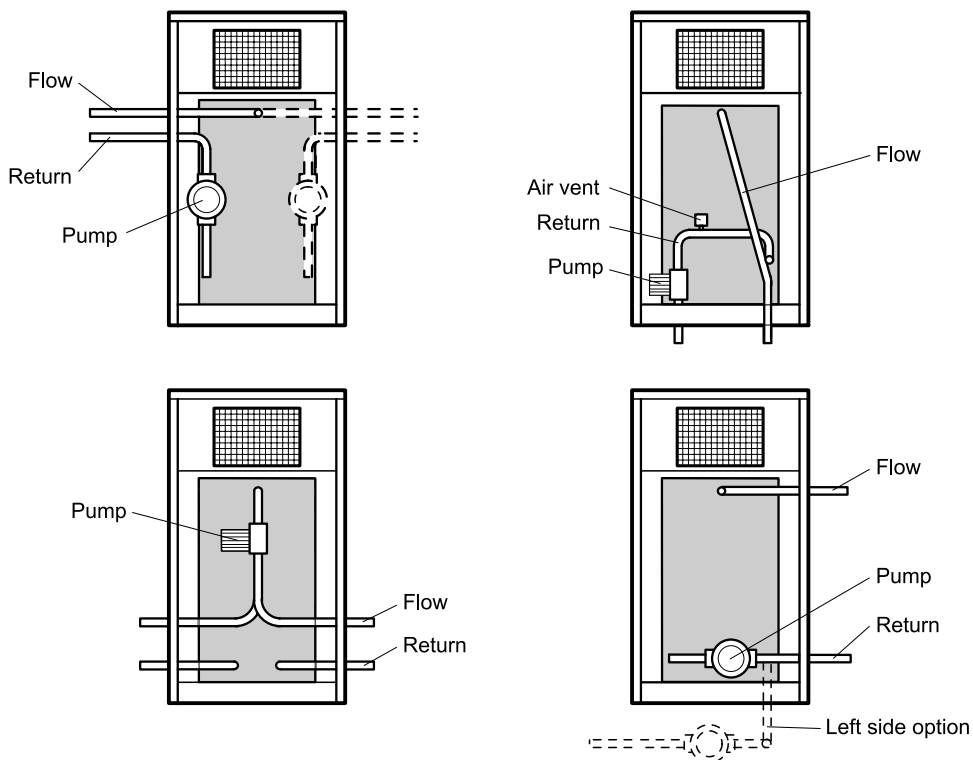

Fig. 14 - 50/70, 70/90 and 90/120 Water connections



Note: If the pump is fitted in the flow:

Open system - A manual air vent must be fitted. **Sealed system** - An automatic air vent must be fitted.

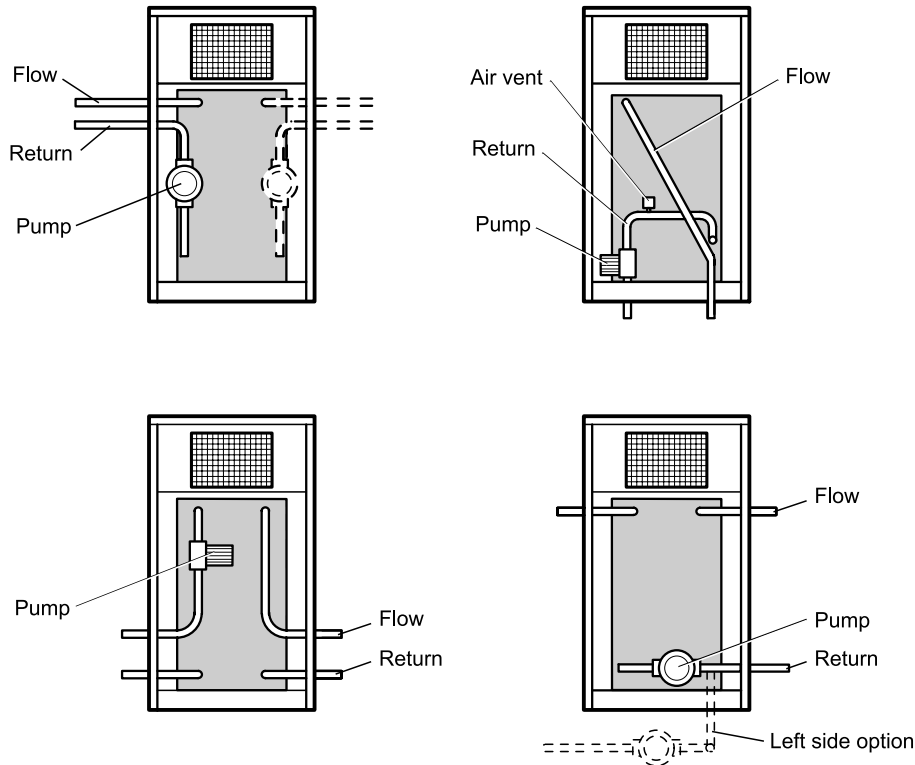

Fig. 14a - 110/140 Water connections

4.5 Sealed system kit - 50/70, 70/90 and 90/120

See Figs. 15, 15a and 15b

1 The kit includes the following items:

- Pressure relief valve and automatic air vent assembly
- 3/4" x 3/4" BSP connector assembly with washer
- 10 litre expansion vessel (50/70, 70/90)
(12 litre for 90/120)
- Sealing washer (red)
- Filling loop kit
- Pressure gauge
- Circulating pump
- Two 1" BSP x 22 mm compression bent pipe connectors
(1 1/4" x 28 mm for 90/120)
- Two 1 1/4" BSP x 22 mm pump unions with washers
(1 1/4" x 28 mm for 90/120)
- 15 mm copper pressure relief valve discharge pipe

- 2 Unscrew the 3/4" x 3/4" BSP connector from the pressure relief valve/automatic air vent assembly, and keep the sealing washer. Using a suitable pipe sealant, fit the connector into the tapping at the centre top front of the boiler (above the burner), with the iron fitting into the boiler.
- 3 Connect the relief valve/automatic air vent assembly to the 3/4" connector, using the sealing washer and secure in position by tightening the union nut. See Fig. 15.
- 4 Connect the free end of the flexible hose to the expansion vessel, ensuring that the red sealing washer provided is fitted. Tighten the union nut on the flexible hose and place the expansion vessel on top of the boiler heat exchanger. See Fig. 14.



4 - BOILER INSTALLATION

- 5 Fit the pressure relief valve discharge pipe. See Fig. 14.

Note: For 70/90 model use the pipe as supplied. For the 50/70 model **reduce the length of the longer leg of the pipe by 75 mm and the shorter leg by 20 mm.** For the 90/120 model **reduce the length of the longer leg of the pipe by 55 mm.**

Fit the end of the longer leg of the pipe into the hole in the bottom of the left hand side panel (when looking towards the burner). It will be necessary to compress the insulation at the front bottom corner of the side panel to locate the hole for the pipe.

Unscrew the pressure relief valve, and keep the sealing washer. Fit the upper end of the pipe into the nut and olive in the pressure relief valve outlet. Re-fit the pressure relief valve using the sealing washer and secure by tightening the union nut. Secure the pipe to the relief valve by tightening the nut and olive.

Ensure that the end of the pipe protruding from below the side panel is approximately **25 mm clear of the ground level** and clear of any obstructions.

- 6 Connect the heating flow to the top tapping on the back of the boiler using one of the bent pipe connectors supplied.
- 7 Connect the pump to one of the bottom tappings (as required) on the back of the boiler using the two pump unions and the other bent pipe connector supplied. Seal the other return tapping with the blanking plug supplied with the boiler. See Fig. 15a.

- 8 The filling loop kit and pressure gauge supplied, should be located in a convenient and easily accessible position inside the house, where the gauge will be visible to the User (see Fig. 15b).

Fit the double check valve to the mains water supply, ensuring correct flow direction as indicated by the arrow on the valve. Fit the pressure gauge and shut-off valve to the central heating system. Fit the flexible filling hose between the two valves.

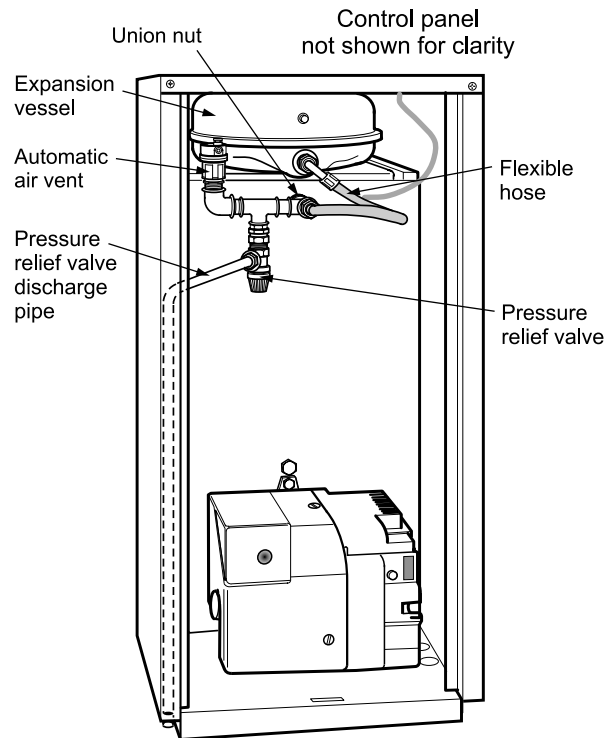

Fig. 15

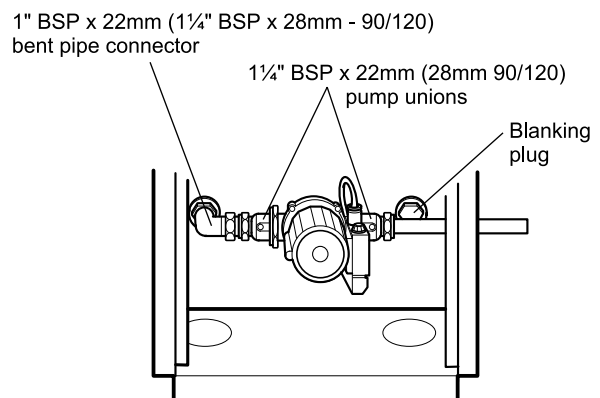

Fig. 15a - Rear of boiler

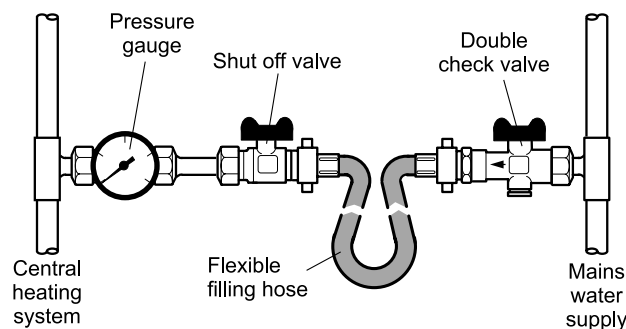

Fig. 15b



4.5a Sealed system kit - 110/140

See Figs 15a, 15b, and 15c

The kit includes the following items:

- 1 The kit includes the following items:
 - Automatic air vent/pressure relief valve assembly
 - 15 mm pressure relief valve discharge pipe assembly
 - Expansion vessel (12 litre)
 - Drain cock/flexible hose connection assembly
 - Flexible hose and sealing washer
 - Pressure gauge assembly
 - Filling loop kit
 - Circulating pump and fittings
- 2 The automatic air vent/pressure relief valve (AAV/PRV) assembly should be fitted to one of the two ½" BSP tappings in the top of the boiler (the other tapping being used for the thermostat pocket - see section 4.4).

Note: If both the flow and return connections are taken from the same side of the boiler, then the thermostat phials should be located on the same side as the connections.

- 3 Separate the bent coupling from the AAV/PRV assembly and screw into the tapping, using a suitable sealant or PTFE tape on the male thread of the coupling, finally aligning the compression connection to face towards the centre of the boiler.
- 4 Fit the pipe elbow of the AAV/PRV assembly into the bent coupling, such that the PRV control faces towards the front of the boiler. Tighten the compression connection.

Note: As supplied, the AAV/PRV assembly is suitable for fitting in the right hand tapping of the boiler. If it is to be fitted in the left hand tapping, it will be necessary to rotate the bent coupling through 180 degrees.

- 5 Take the two sections of 15 mm pipe supplied and join together using the 15 mm tectite connector, ensuring that the machine pulled bend is at one end of the pipe (see Fig. 15c). Fit the 15 mm pressure relief pipe to the PRV assembly using the short piece of 15 mm tube and 15 mm tectite elbow supplied. Ensure that the end of the pipe protrudes through the base of the side panel and is clear of the ground level and any obstructions. Tighten the nut and olive on the PRV assembly.

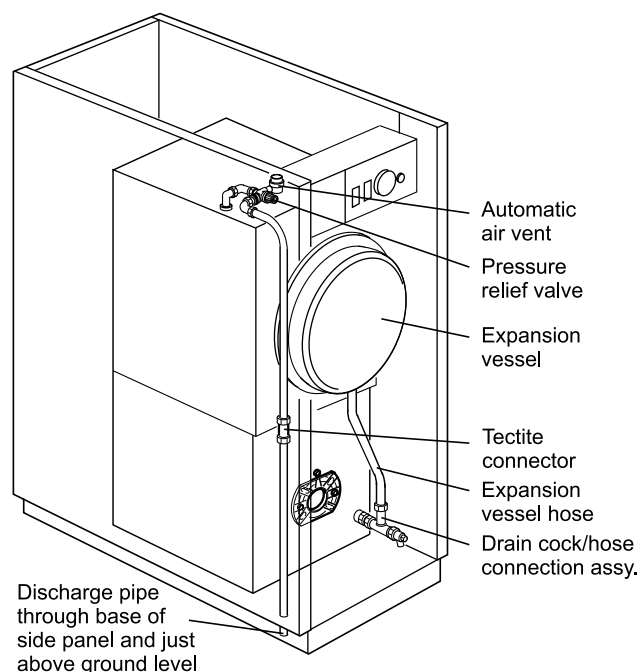

Fig. 15c

- 6 Fit the drain cock/flexible hose connection assembly to the drain cock connection (at the bottom right front of the boiler as follows:
 - a Undo the single burner fixing nut (top of mounting flange) and withdraw the burner from the boiler. Unscrew and remove the existing drain cock.
 - b Unscrew and remove the threaded connector from the union on the end of the drain cock/hose connection assembly. Screw the connector into the drain cock tapping on the boiler, using a suitable sealant or PTFE tape to seal.
 - c Re-connect the drain cock/hose connection assembly to the connector, with the hose connection pipe upwards, and tighten the union (see Fig. 15c).
- 7 Connect one end of the expansion vessel hose to the ½" BSP connection on the drain cock/hose connection assembly, ensuring that the rubber sealing washer is fitted inside the union nut.
- 8 Fit the expansion vessel assembly on the front of the boiler as follows:
 - a Connect the free end of the expansion vessel hose to the ¾" BSP connection on the bottom of the expansion vessel assembly, ensuring that the rubber sealing washer is fitted inside the union.
 - b Hang the assembly on the upper of the two handles on the front access door, using the hook on the expansion vessel bracket.



4 - BOILER INSTALLATION

- 9 If required, fit the circulating pump to one of the four tapplings on the back of the boiler (see Fig. 14a). Two 1/4" x 28 mm pump unions, two 1" BSP bushes and two 1" BSP x 28 mm elbows are supplied. Seal any unused tapplings with the 1/4" BSP plugs supplied (see Fig. 15a).
- 10 The filling loop kit and pressure gauge supplied should be located in a convenient and easily accessible position inside the house, where the gauge is visible to the User, see Fig. 15b, as follows:
 - a Connect the double check valve to the mains water supply, ensuring correct flow direction as indicated by the arrow on the valve.
 - b Connect the pressure gauge and shut-off valve to the central heating system.
 - c Fit the flexible filling hose between the two valves.
- 5 If the circulating pump is to be fitted within the boiler enclosure, the pump live must be connected to terminal 7 of the boiler terminal block.

Pass the pump power supply cable through the cable grommet in the control panel, through the cable clamp and connect to the terminal block as follows:-

 - Earth (green/yellow) to terminal 10 - marked E
 - Neutral (blue) to terminal 9 - marked N
 - Live (brown) to terminal 7

Connecting the pump in this way allows it to be isolated using the isolating switch fitted in the boiler control panel, for servicing or maintenance work.

4.6 Connect the power supply

See wiring diagrams in section 8

Note: A test switch is fitted to the control panel to allow the boiler to be test-fired. When On, the switch by-passes the external control system.

- 1 Undo the three screws and remove the lefthand cover from the control panel to gain access to the boiler terminal block.
- 2 Pass the mains power supply cable through the cable grommet in the control panel, through the cable clamp and connect to the terminal block as follows:-
 - Live (brown) to terminal 2 - marked permanent live
 - Neutral (blue) to terminal 3 - marked mains neutral
 - Earth (green/yellow) to terminal 4 - marked mains earth
- 3 If simple external controls are to be connected to the boiler (e.g. gravity hot water and pumped heating), ensure the link is removed between 7 and 8, see Fig. 29.
- 4 If an external control system is to be connected to the boiler (e.g. a Y-plan system with programmer, room thermostat, cylinder thermostat, motorised valves, etc.), connect the 'switched live' from the control system to terminal 1. For an example of connecting a typical control system, see Fig. 26 or 27.

- 6 Ensure that the cable clamp is tightened and that all cables are secure.
- 7 Replace the cover on the control panel, with the yellow warning label facing outwards and secure with the three screws.

Do not switch on the electrical power to the Outdoor Module at this stage.



4.7 Connect the fuel supply

See Fig. 6

If a two pipe system is to be used refer to section 3.3.6.

- 1 Remove the plug from the fuel pump oil inlet adaptor and connect the elbow of the flexible fuel line supplied with the boiler.
- 2 Connect the flexible fuel line to the rigid supply using the adaptor supplied. The supply enters the enclosure through one of the holes in the bottom of the side panels.

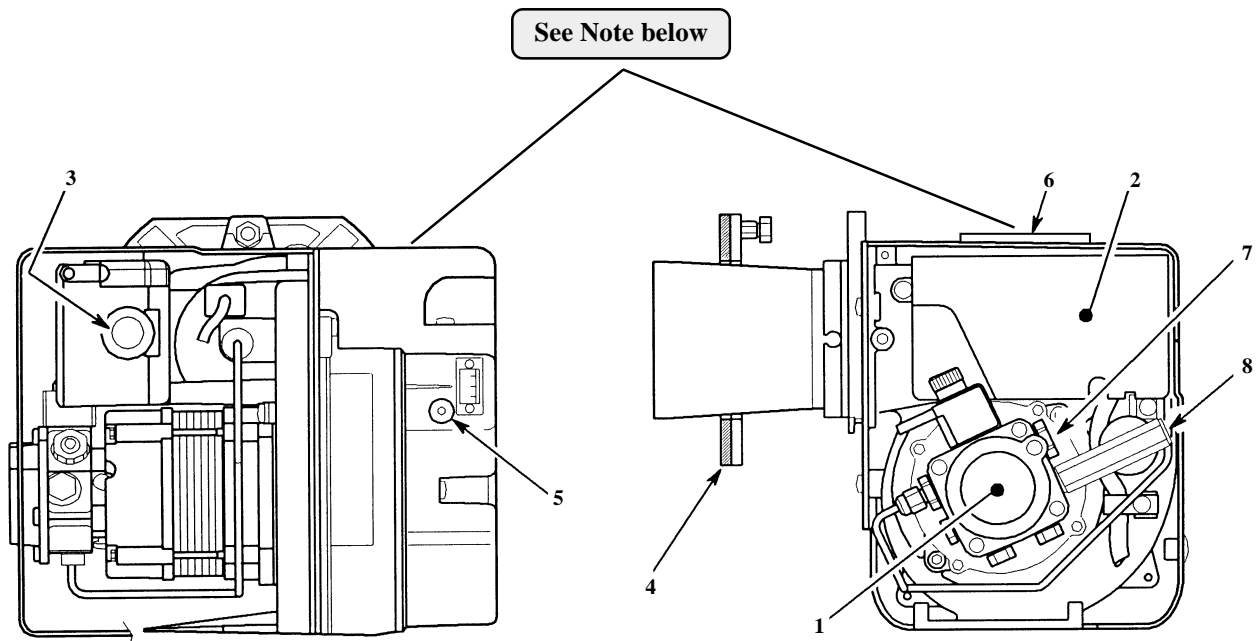

Fig. 16 - RDB burner components

- | | |
|--|--|
| <ol style="list-style-type: none"> 1 Pump 2 Control box 3 Reset button with lock-out lamp 4 Flange with gasket (do not remove from boiler) | <ol style="list-style-type: none"> 5 Air damper adjustment screw 6 Air supply tube connection (balanced flue) 7 Pump pressure adjustment screw 8 Pressure gauge connection |
|--|--|

Note:

Remove the factory fitted air inlet spigot adaptor (item 6, above) from the air intake on the top right hand side of the burner and fit the grey plastic air inlet grille in its place.



4.8 *Fill and vent a sealed system*

Expansion vessel pressure

The expansion vessel fitted is supplied with a charge pressure of 1.0 bar (equivalent to a max. static head of 10.2 metres). The charge pressure must not be less than the actual static head at the point of connection, i.e. the height of the highest point of the heating system above the connection on the expansion vessel. Do not pressurise the vessel above 1.5 bar.

The air pressure in the vessel must be checked annually.

The maximum central heating system volume, using the 10 litre expansion vessel as supplied with the 50/70, 70/90 kit is approximately 75 litres. Using the 12 litre vessel supplied with the 90/120, 110/140 kit the volume is approximately 90 litres. If the system volume is greater, an extra expansion vessel (complying with BS 4841) must be fitted to the system, in any one of the alternative locations as shown in Fig. 8. The charge pressure of the extra vessel must be the same as the vessel fitted on the boiler. Refer to BS 7074:1 for further guidance.

The air charge pressure may be checked using a tyre pressure gauge on the expansion vessel Schraeder valve. The vessel may be re-pressurised using a suitable pump. When checking the air pressure the water in the heating system must be cold and the system pressure reduced to zero.

A simple test to check if the expansion vessel size is adequate, is to fully heat the system and if the pressure rises to no more than 2.0 bar the vessel is adequate. A higher figure indicates that an extra vessel is required.

Fill the system

- 1 An automatic air vent is fitted to the top of the boiler (see Fig. 15 or 15c). Check that the small cap on the top of the air vent is screwed on fully, then unscrew it one complete turn - the cap remains in this position from now on.
- 2 Ensure that any valves in the heating system pipework are open.
- 3 Ensure that the flexible filling loop is fitted between the shut off valve on the mains water supply and the double check valve on the heating system.
- 4 Open the mains shut off valve and then gradually open the valve on the double check valve until water is heard to flow. The valves are fully open when the operating lever is in line with the valve body and closed when it is at right angles to it.
- 5 Fill the system until the pressure gauge indicates a pressure of approximately 1.5 bar. Close both the filling loop valves and check the system for water soundness, rectifying where necessary.
- 6 Vent each radiator in turn, starting with the lowest in the system, to remove the air.
- 7 It is important that the circulating pump is properly vented to avoid it running dry and damaging its bearings. Prise off the plastic cover in the centre of the pump, unscrew and remove the vent plug. Insert a suitable screwdriver into the end of the pump shaft and rotate it at least one complete turn. Replace the plug and refit the plastic cover.
- 8 Check the operation of the pressure relief valve (see Fig. 15 or 15c) by turning the head anticlockwise until it clicks. The click is the valve lifting off its seat allowing water to escape from the system. Check that this is actually happening, and water flows unobstructed from the relief discharge pipe.
- 9 Continue to fill the system until the pressure gauge indicates 1.0 bar. Close the filling valve and cold water inlet valve and check the boiler and system for water soundness, rectifying where necessary. Water may be released from the system by manually operating the safety valve until the system design pressure is obtained.
- 10 The system design pressure (cold) should be between 0.8 and 1.0 bar. This pressure is equivalent to the maximum static head in bar + 0.3 (1 bar = 10.2 metres of water). Set the adjustable pointer on the pressure gauge to the system design pressure.
- 11 On completion of filling, ensure that both filling loop valves are closed and disconnect the flexible hose.



Refer to Fig. 17 for boiler controls

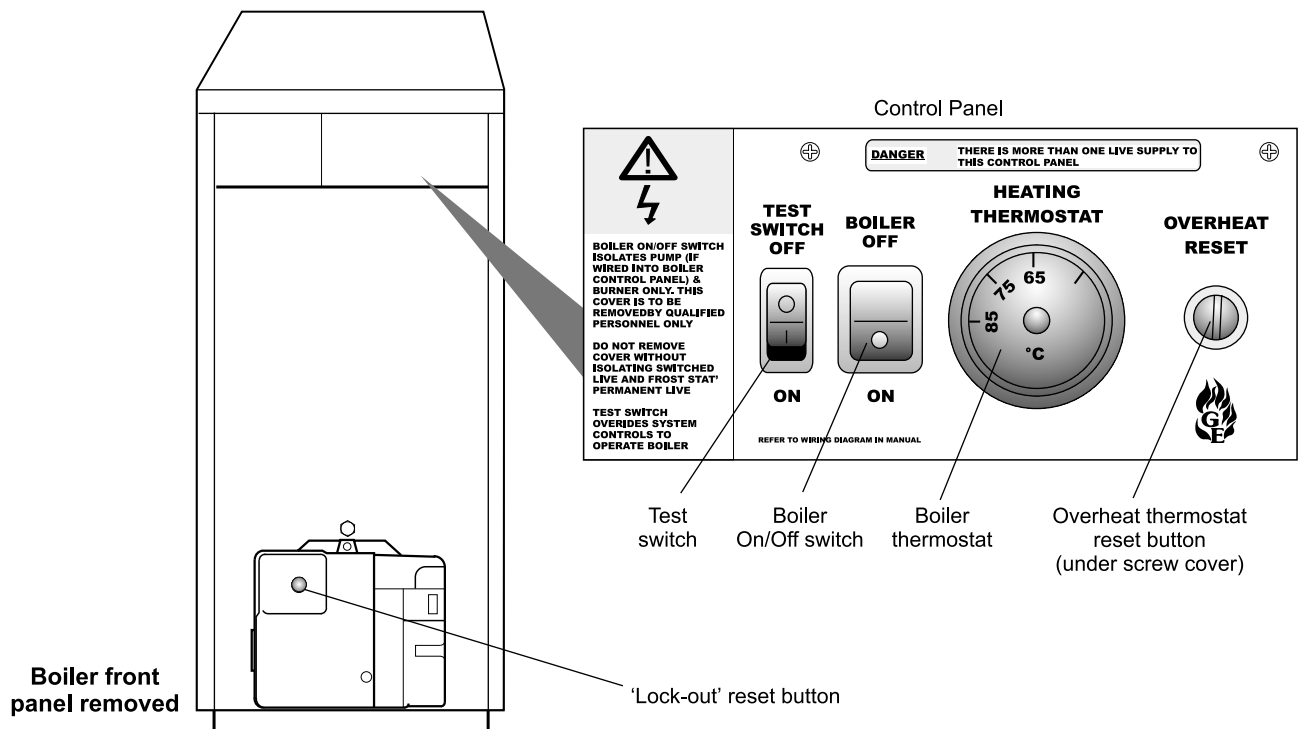

Fig. 17

It is important that the following commissioning procedure is carried out to ensure safe and efficient operation of the boiler.

Note: A test switch is fitted to the control panel to allow the boiler to be test-fired. When On, the switch by-passes the external control system.

If the boiler fuel or output is to be adjusted from that which is factory, set refer to section 2.2 or 2.3 for the required settings and section 7.4 for burner nozzle change instructions.

Note: Check that the baffles are in position and that the cleaning cover is correctly fitted and a good seal made.

- 1 Check that the water system has been vented (and pressurised if sealed system) and there are no leaks.
- 2 Check that all fuel line valves are open.
- 3 Remove the plastic burner cover (two screws) if it was not previously removed.
- 4 Connect a combined vent manifold and pressure gauge to the pressure gauge connection port on the oil pump. See Fig. 16. Open the vent screw on your vent manifold to vent the supply while the pump is running.
- 5 Check that all system controls are calling for heat and turn the boiler thermostat to maximum. Switch on the electricity supply.

Note: The boiler will start as soon as the electricity supply to it is switched on.

- 6 The burner fan should start and the burner should light within about 20 seconds. If the burner does not light and the 'Lock-out' reset button lights, wait for about 45 seconds then press the reset button to restart the ignition process. This procedure may have to be repeated several times during first lighting.
- 7 With the burner alight, check the fuel pressure. Refer to the Technical Information, section 2.2 or 2.3. Adjust the pressure if necessary - see Fig. 16.
- 8 Operate the boiler until it reaches normal operating temperature. Check oil pipes for leaks, rectifying where necessary.
- 9 With the burner alight, re-check the fuel pressure and re-adjust if necessary. Turn the boiler off, remove the pressure gauge and replace the plug in the pump.



5 - COMMISSIONING

- 10 Having ensured that there are no oil leaks, replace the burner cover.
- 11 Relight the boiler and allow it to run for 20 minutes then check the following:-
CO₂ level, Flue gas temperature and Smoke Number. Refer to the Technical Information in section 2.2 or 2.3.

Insert combustion probe into the end of the flue terminal to measure the CO₂ level.
Do not use the test point on top of the boiler.

- 12 Check the smoke number, if satisfactory check the CO₂. Use the hexagonal key supplied to adjust the burner air damper (see Fig. 16) as required. Turning the screw clockwise opens the damper and reduces CO₂ level, turning the screw anticlockwise closes the damper and increases CO₂ level.
Re-check the smoke number if the air damper has been moved.
Under no circumstances must the smoke number be above 1.
A suitable position for the air damper is one which gives 1% less CO₂ than that which has a smoke number of 1.

Note: To obtain the correct CO₂ level, the final flue gas reading must be taken with all casing panels fitted.

Note: It is important that the air damper is correctly set.

- 13 Check the flue gas temperature.

- 14 When the boiler has been adjusted and is running satisfactorily, balance the central heating system by adjusting the radiator lock shield valves. Start with the radiator nearest the boiler and adjust the valves to achieve the required temperature drop across each radiator.
If thermostatic radiator valves have been installed, check the system by-pass.

- 15 Switch off the boiler.

- 16 With the hot water system hot, check again for leaks, rectifying where necessary. Drain the system while it is hot to complete the flushing process. Refill and vent (and pressurise if a sealed system) the system.

17 A suitable central heating system inhibitor must be added to protect the system against the effect of corrosion.

- 18 Replace the top, front and rear panels.

If the boiler is to be left in service with the User, set the controls and room thermostat (if fitted) to the User's requirements then refer to section 6.

If the boiler is not to be handed over immediately, close the boiler fuel supply valve and switch off the electricity supply.

If there is any possibility of the boiler being left during frost conditions, then the boiler and system should be drained.



The User must be advised (and demonstrated if necessary) of the following important points:-

- 1 How to light and turn off the boiler and how to operate the system controls.
- 2 The precautions necessary to prevent damage to the central heating system and to the building, in the event of the boiler not being in operation during frost conditions.
- 3 The importance of servicing the boiler to ensure safe and efficient operation. This should be done once a year.
- 4 The type of fuel used.
- 5 That any servicing or replacement of parts must only be carried out by a suitably qualified engineer.
- 6 Ensure that the boiler controls and room thermostat (if fitted) are set to the User's requirements.
- 7 If the boiler is used on a sealed heating system, tell the user the system pressure and show them the position of the safety valve discharge pipe and pressure gauge.
- 8 Show the User how to reset the overheat thermostat and how to restart the boiler if it goes to 'Lock-out'.

Leave this Instruction manual with the User.

7 - BOILER SERVICING

To ensure efficient operation of the boiler it is recommended that it is checked and serviced as necessary at regular intervals. The frequency of servicing will depend upon the particular installation conditions and usage, but must be done at least annually.

Servicing and replacement of parts must only be carried out by a suitably qualified engineer.

Important: Details of every service should be entered in the Service Log, on page 2 of these instructions. This information may be required to validate the Grant extended warranty.

Warning note: External equipment operated at 230 volts should not be serviced or repaired under adverse weather conditions.

IMPORTANT

Before starting any work on the boiler, or fuel supply please read the health and safety information given in section 12 on page 43.

Note: A test switch is fitted to the control panel to allow the boiler to be test-fired. When On, the switch by-passes the external control system.

7.1 Important notes prior to servicing

- 1 Check the flue terminal and ensure it is not blocked or damaged.

- 2 Run the boiler and check the operation of its controls.
- 3 If a sealed system kit is fitted, check the charge pressure in the expansion vessel is 1 bar (factory setting).
- 4 Ensure that all water/fuel system connections and fittings are sound. Remake any joints and check the tightness of any fittings that may be leaking. If the boiler is used on a sealed central heating system, check the system pressure. Refill, vent and re-pressurise the system as necessary.
- 5 Check that the louvres in the front panel are clear.
- 6 Check for any sludge/water from the fuel tank.
- 7 With the fuel supply valve closed, clean/replace the filter element and clean the filter bowl.
- 8 Flexible fuel supply pipes should be inspected annually when the boiler is serviced and replaced every two years. If in doubt replace the pipes.

Warning: Before servicing, isolate the electricity supply to the burner and pump (if fitted inside the boiler enclosure) and close the fuel supply valve. Allow the boiler to cool.

Important: Do not remove the cover from the control panel without isolating the electrical supply at the fused isolator in the house.

The data label on the inside of the enclosure side panel will indicate the nozzle fitted.



7.2 Dismantling prior to servicing

- 1 Remove the front panel by turning the handle and withdrawing it forwards at the bottom.
- 2 Remove the four screws securing the top panel and carefully lift it off (50/70, 70/90 and 90/120 models only), taking care not to damage the insulation.

Note: The top panel has been designed to provide a slight fall away from the side positioned against a wall, the side of the top panel with the fixing screws closer to the bottom edge is the highest side and goes against the wall.

- 4 Remove the burner fixing nut (top of the mounting flange) and withdraw the burner. If required, disconnect the flexible oil pipe(s), use a suitable container to prevent any oil spillage.

Note: If two flexible pipes are connected to the burner, identify (mark if necessary) which is the inlet and return if they are to be disconnected.

7.3 Cleaning the boiler

See Figs. 18, 19, 20, 21 or 22

- 1 If a sealed system kit is fitted, lift the expansion vessel off the boiler.
- 2 On the 50/70, 70/90 and 90/120 models remove the two nuts and washers securing the cleaning cover to the top of the boiler and lift off the cover. Take care not to damage the seal.
On the 110/140 model remove the four nuts and washers securing the cleaning cover on the front of the boiler and remove the cover. Take care not to damage the seal.
- 3 Remove the baffles, noting their position (see Figs. 18, 19, 20, 21 or 22).
- 4 Remove all deposits from the baffle plates and all the boiler internal surfaces using a stiff brush and scraper if necessary.
- 5 Check the condition of the flue, clean as necessary.
- 6 Check the condition of the cleaning cover seal, replace if necessary.

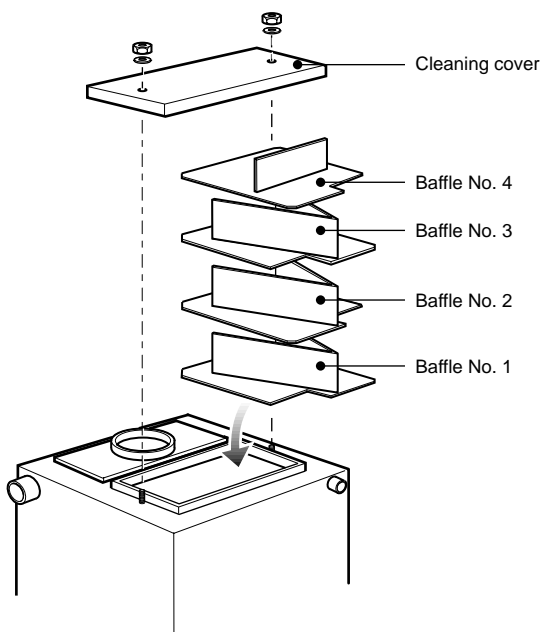

Fig. 18 - 50/70 baffle positions

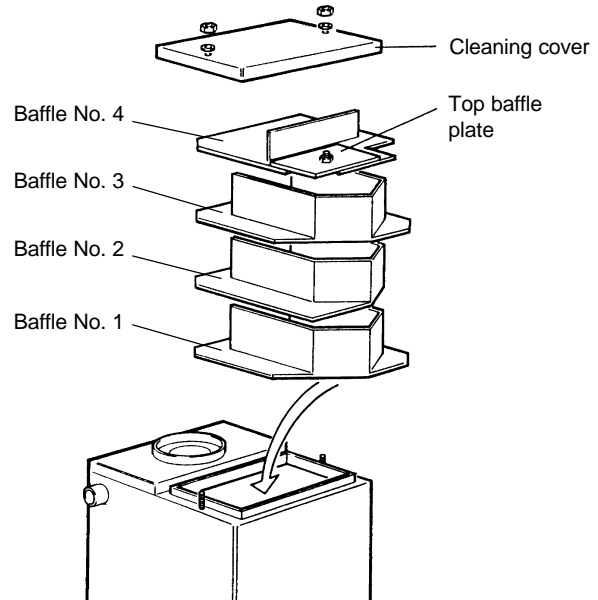

Fig. 19 - 70/90 baffle positions



- Replace the baffles, ensuring they are correctly fitted. See Figs. 18, 19, 20,21 or 22.
On 70/90 model, ensure that the plate on the top baffle (see Fig. 19) is in the correct position, i.e. on the left hand side when viewed from the front of the boiler.

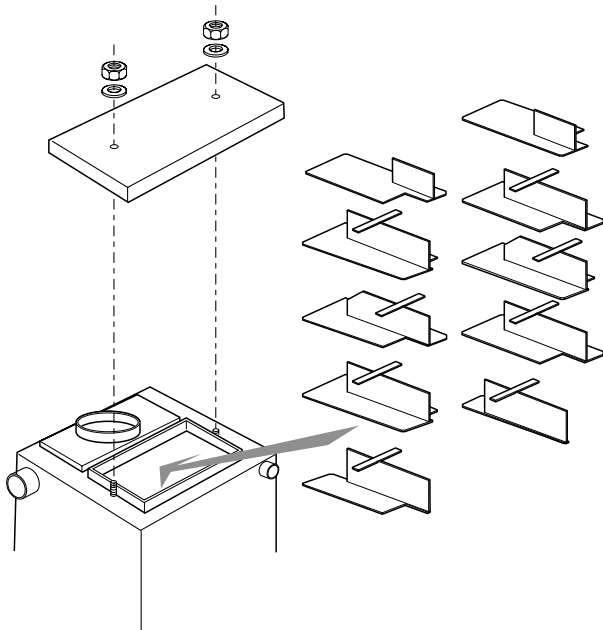
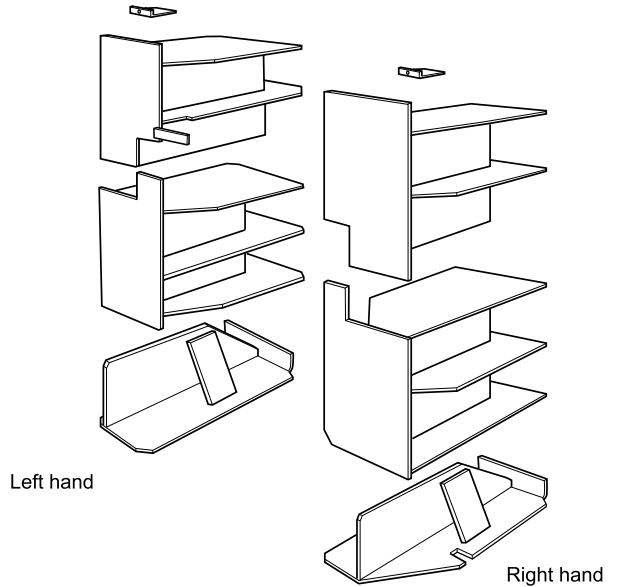

Fig. 20 - 90/120 baffle arrangement

- Replace the cleaning cover, securing it in position with the nuts and washers previously removed.
- If a sealed system kit is fitted, replace the expansion vessel on to the boiler.



Note: Secure plate in position as shown for 140 000 Btu/h output
Remove plate completely for 110 000 Btu/h output

Fig. 21 - 110/140 baffle arrangement

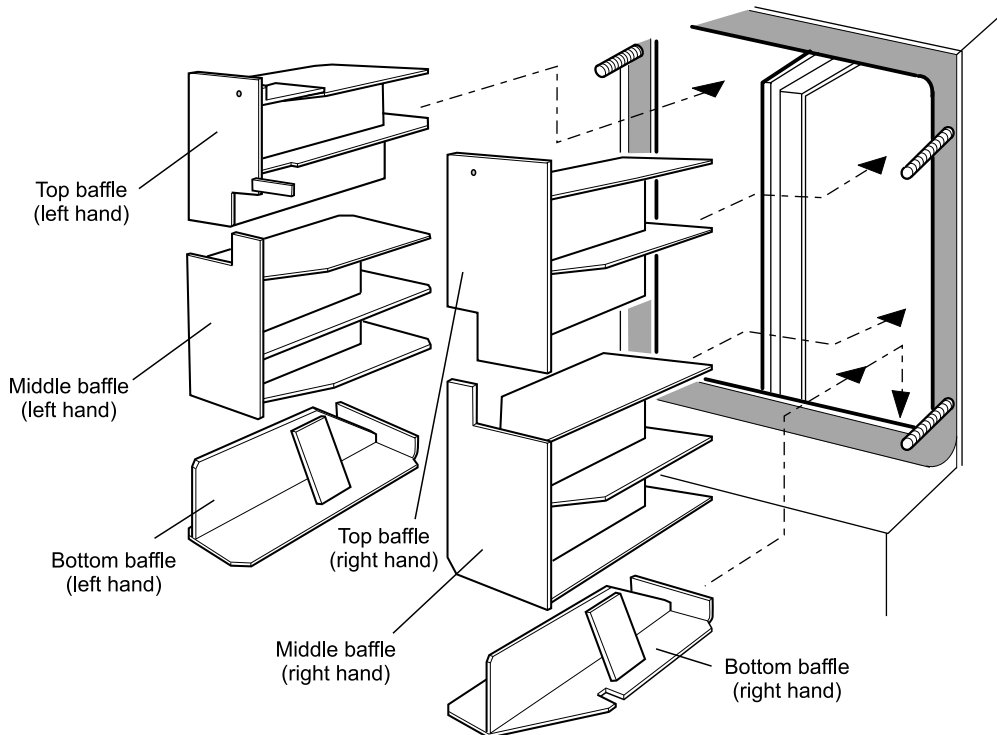

Fig. 22 Baffle positioning - 110/140



7.4 Cleaning the burner

See section 11.1

- 1 Combustion head** - Loosen the two screws securing the combustion head to the burner flange and withdraw the head. Clean and replace the combustion head.
- 2 Inspect the ignition electrodes** - With the combustion head removed, loosen the electrode clamp screw and withdraw the electrode assembly. Wipe clean and check for any cracks in the ceramic insulation. Replace if necessary.
Check the electrode settings - Electrode tips approximately 4 mm apart and 2 to 2.5 mm (50/70) or 3 to 3.5 mm (70/90, 90/120, 110/140) in front of the nozzle, see Fig 23.
- 3 Nozzle** - Check that the nozzle size and type are correct, refer to table in section 2.2 or 2.3 and boiler data label. Clean the nozzle with kerosene if necessary. Do **not** use a pin or piece of wire to clean the nozzle. Replace the nozzle if a build up of carbon is present. With the combustion head removed, loosen the electrode assembly clamp screw and slide the electrodes away from the nozzle. Remove the nozzle using a good fitting spanner (16 mm). The use of an ill-fitting spanner will damage the nozzle and could lead to an incorrect flame pattern. Always check the electrode settings after replacing the nozzle, see Fig. 23.

- 4 Photocell** - The photocell (item 11 in section 11.1) is a push-fit in the burner body. Carefully pull out the photocell to clean.
- 5 Fan** - With the air intake grille removed, remove the screws securing the fan housing cover (R/H side of burner) and remove the cover. Inspect the fan and housing and clean as necessary. Replace the cover.
- 6 Pump filter** - With the burner cover removed, remove the four screws securing the pump end cover. Remove the filter and wash in kerosene. Replace the filter and end cover, ensure the 'O' ring is in position.

Re-assemble in reverse order.

To ensure safe and efficient operation of the boiler it is important that re-commissioning is carried out, especially combustion checks (CO₂ level, flue gas temperature and smoke number) after the boiler has been serviced.

Refer to the Commissioning instructions starting on page 29.

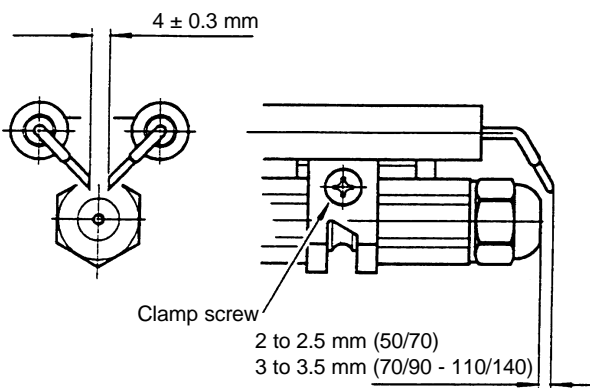
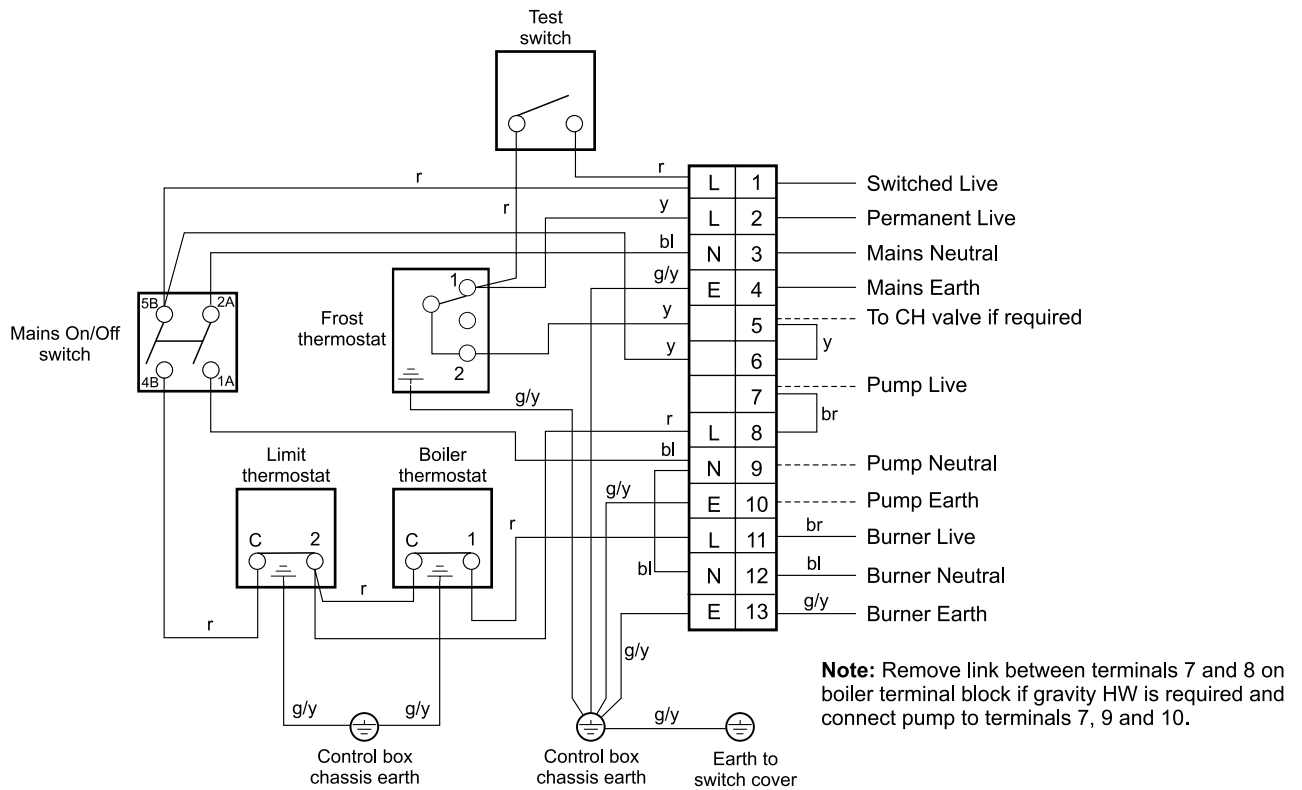

Fig. 23 (70/90, 90/120, 110/140 RDB shown)

IMPORTANT: The electrode settings given above MUST be observed



8.1 Outdoor Module wiring diagram



Colour code: br - Brown, r - Red, bl - Blue, y - Yellow, g/y - Green/Yellow

Fig. 24

8.2 Grant programmable room thermostat

A programmable room thermostat - Part No. RSKIT is available from Grant UK. The thermostat has a 5/2 day operation and enables six time and temperature changes each day. The thermostat incorporates frost protection and an On/Off facility.

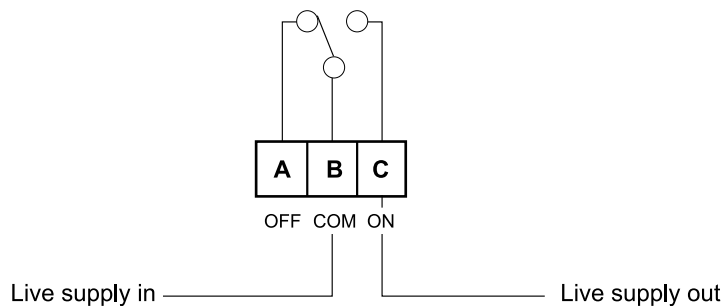

Fig. 25



8.3 Typical control system wiring diagrams

a Honeywell Y Plan - Hot water controlled by mid position valve

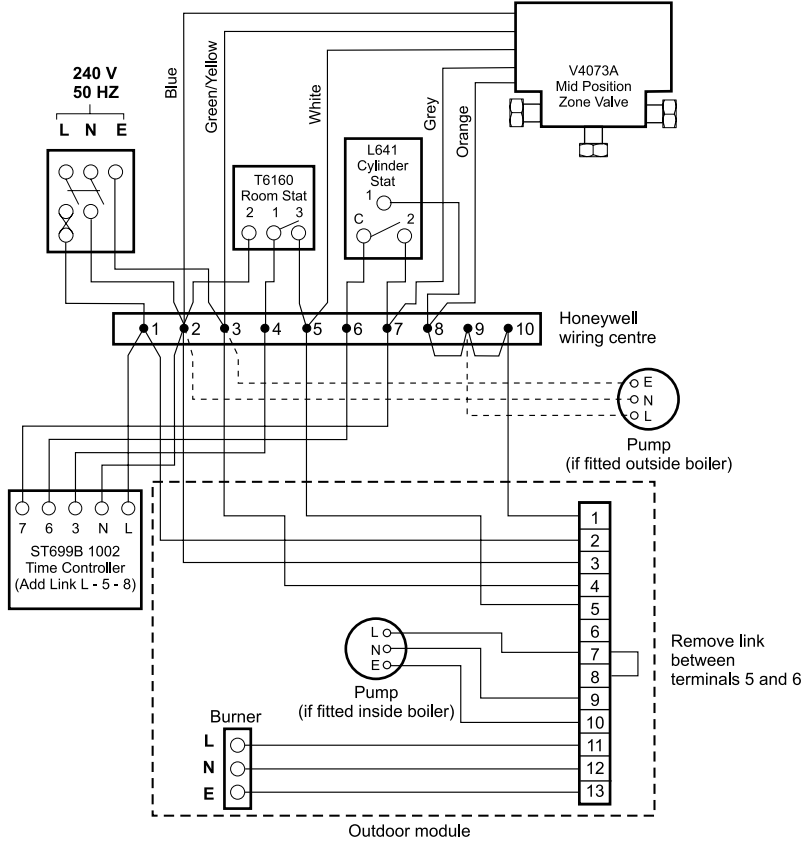

Fig. 26



b Honeywell S Plan - Hot water and Central heating controlled by two valves

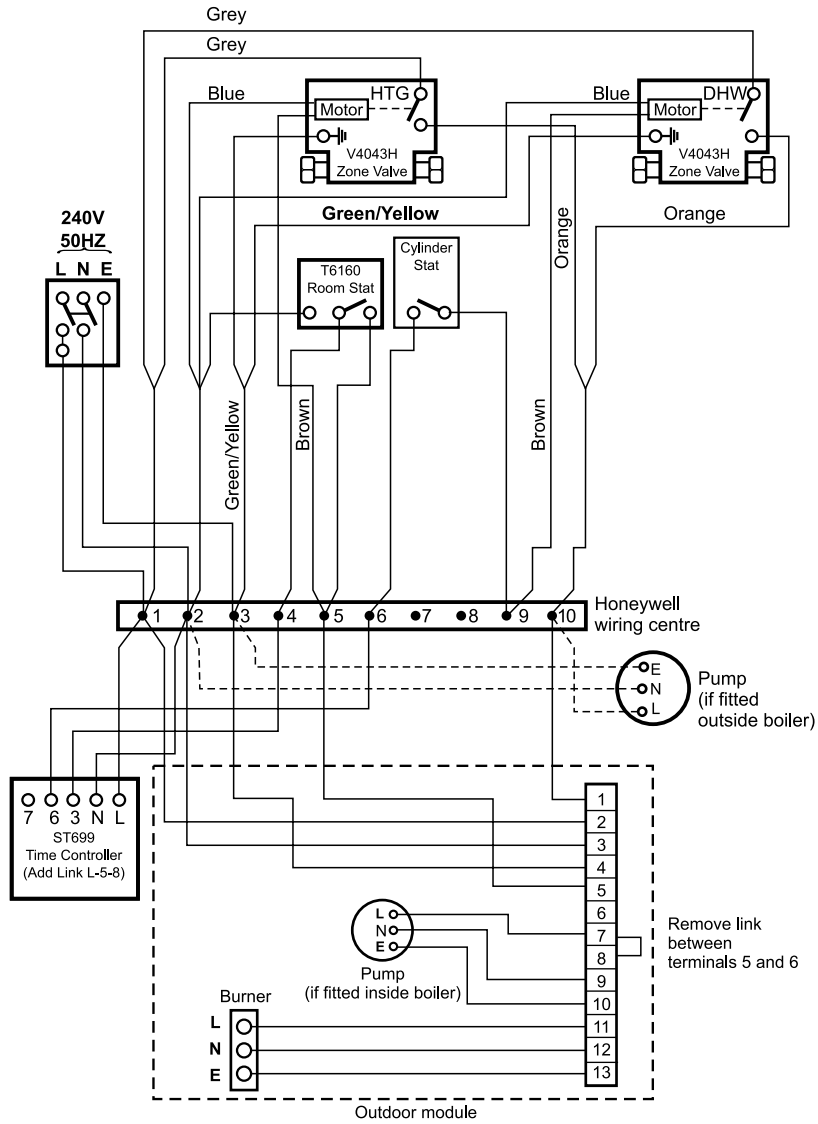
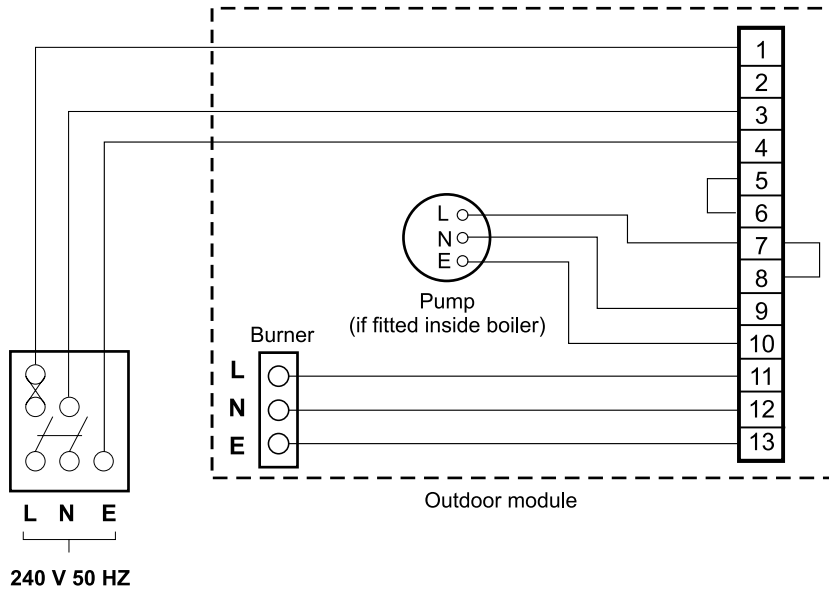

Fig. 27



8.4 Electrical connections - no external controls



Note: The frost thermostat inside the boiler **will not function** when the boiler is connected as above

Fig. 28

8.5 Electrical connections - gravity HW & pumped CH

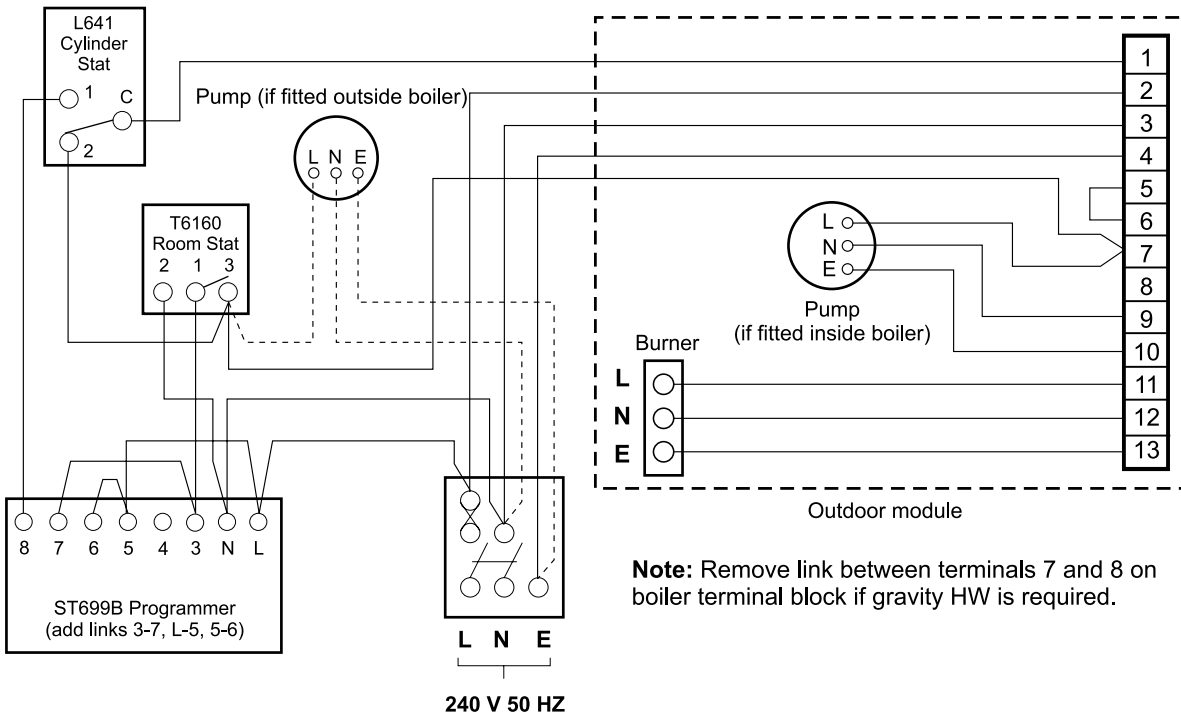

Fig. 29



9.1 Boiler fault finding

Warning: Always isolate the electricity supply to the boiler before working on the boiler.

Faults	Remedies
Boiler will not start	
1 No fuel supply.	Ensure that an adequate supply of fuel is available and that the fuel supply valve is open. Check the condition of the fuel filter, clean if necessary. Ensure fuel supply is reaching burner and vent pump.
2 No electricity supply.	Ensure electricity supply to the boiler is switched on and that all controls are calling for heat. Ensure that the overheat thermostat has not tripped, reset if necessary. Check that a mains supply is present at the burner terminal block. If not, check the boiler and overheat thermostat.
3 Burner not starting - fuel and electricity supplies present.	Press the reset button on the burner control box if it is lit. Refer to burner fault finding flow diagram.
4 Burner lights but goes to 'lock-out'.	If the flame is unstable, check the combustion settings. Refer to burner fault finding flow diagram.
Boiler works but:-	
5 Visible smoke from flue or high smoke number.	Insufficient air supply - check the air damper setting and the condition of the fan. Check the nozzle size and type. Fuel pressure may be too high - check and adjust.
6 Burner pulsates.	Insufficient air supply - check the air damper setting and the condition of the fan. Check the nozzle size and type.
7 Flame slow to stabilise during start up.	Insufficient air supply - check the air damper setting and the condition of the fan. Check the nozzle size and type. Fuel pressure may be too low - check and adjust. Insufficient draught - clean boiler heat exchanger and check condition of flue.
8 Water temperature low.	Undersize nozzle and/or low fuel pressure. Check condition of boiler heat exchanger and clean if necessary. Check the boiler thermostat. Check the combustion settings. Check the condition of the fuel filter.
9 Boiler operating on overheat thermostat.	Faulty boiler thermostat.
10 Oil odours.	Check all fuel line connections, remake as necessary.
11 Combustion fumes smell.	Check boiler cleaning cover and seal are correctly fitted. Check burner is correctly fitted onto flange. Check flue is correctly sealed into flue outlet of boiler.



9.2 Riello RDB burner fault finding

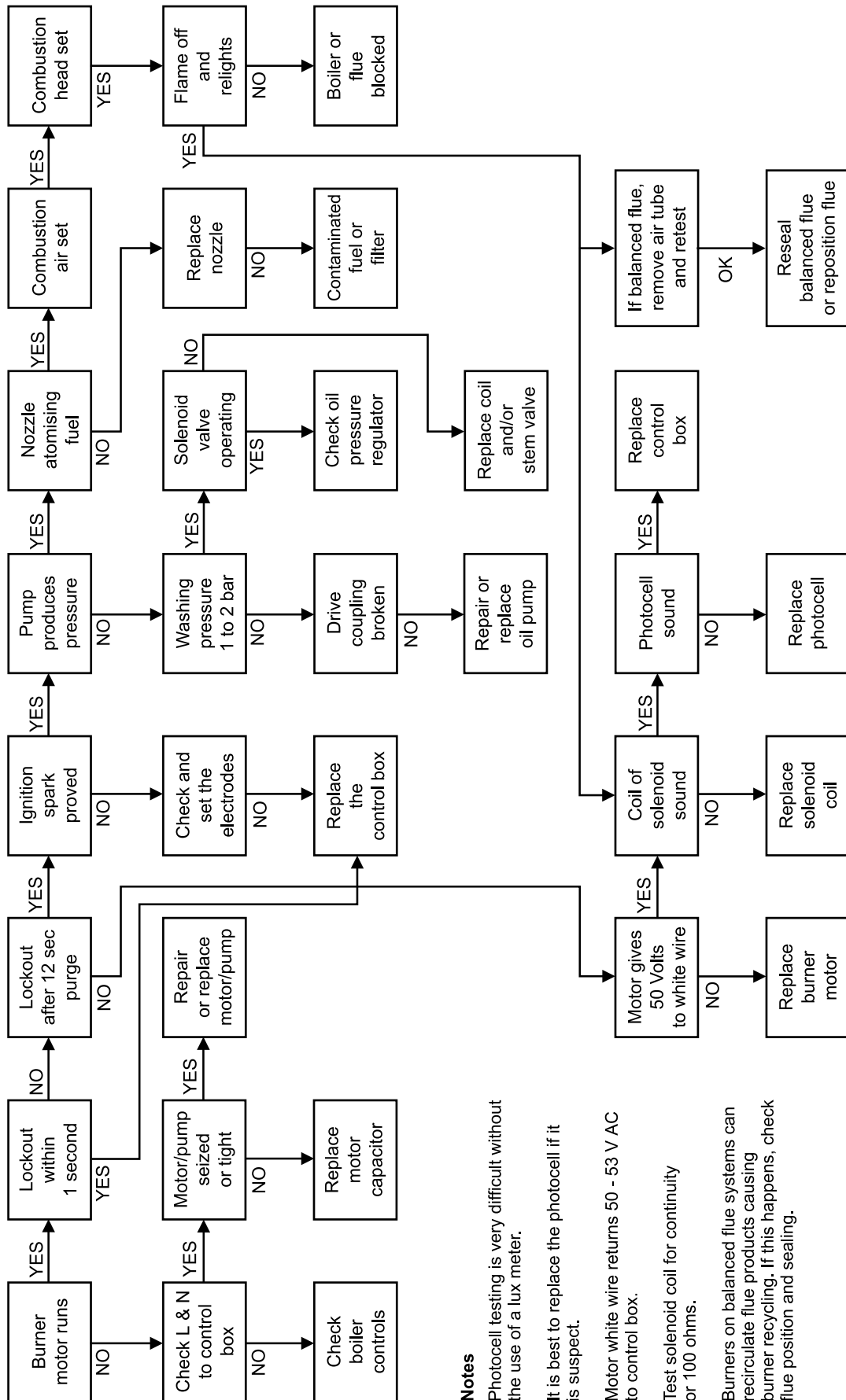

Notes

Photocell testing is very difficult without the use of a lux meter.

It is best to replace the photocell if it is suspect.

Motor white wire returns 50 - 53 V AC to control box.

Test solenoid coil for continuity or 100 ohms.

Burners on balanced flue systems can recirculate flue products causing burner recycling. If this happens, check flue position and sealing.



10.1 Outdoor Module - Spare Parts

Description	Part No.
Thermostat pocket	EFBS10
Cleaning door nut and washer set	EFBS14
Double pole switch	EFBS19
On/Off single pole switch	EFBS21
Frost thermostat	EFBS23
Baffle set - 50/70	EFBS30
Baffle set - 70/90	EFBS09
Baffle set - 90/120	EFBS49
Baffle set - 110/140	MPBS15
Sealed system - Expansion vessel 10 litre - 50/70, 70/90	MPCBS27
Sealed system - Expansion vessel 12 litre - 90/120, 110/140	MPSS01
Sealed system - Water pressure gauge	MPSS02
Sealed system pressure relief valve	MPSS03
Sealed system - Expansion vessel flexible hose	MPSS04
Cleaning cover - 50/70	EFBS17X
Cleaning cover - 70/90, 90/120	EFBS17
Cleaning cover gasket - 110/140	TPBS23L
Overheat thermostat	TPBS33
Boiler thermostat	TPBS34

Burner Heads

LD2SX - 50/70

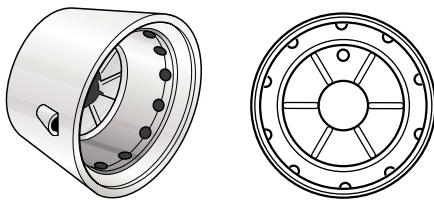

LD3 - 70/90

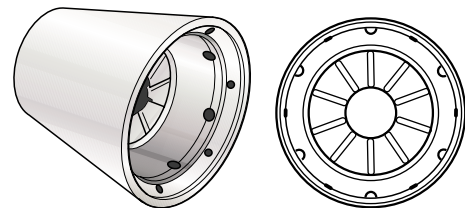

RDB2 burner LD3A - 90/120, 110/140

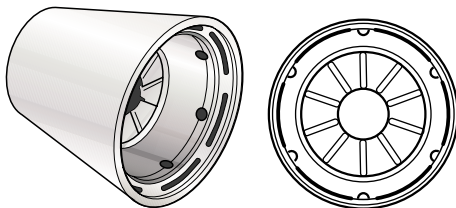

RDB2.1 burner T3 - 90/120, 110/140

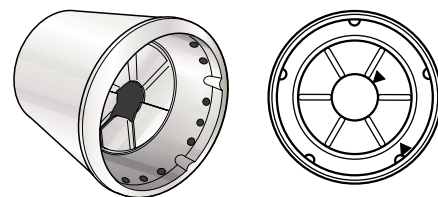



11 - BURNER SPARE PARTS

11.1 Riello RDB burner - exploded view

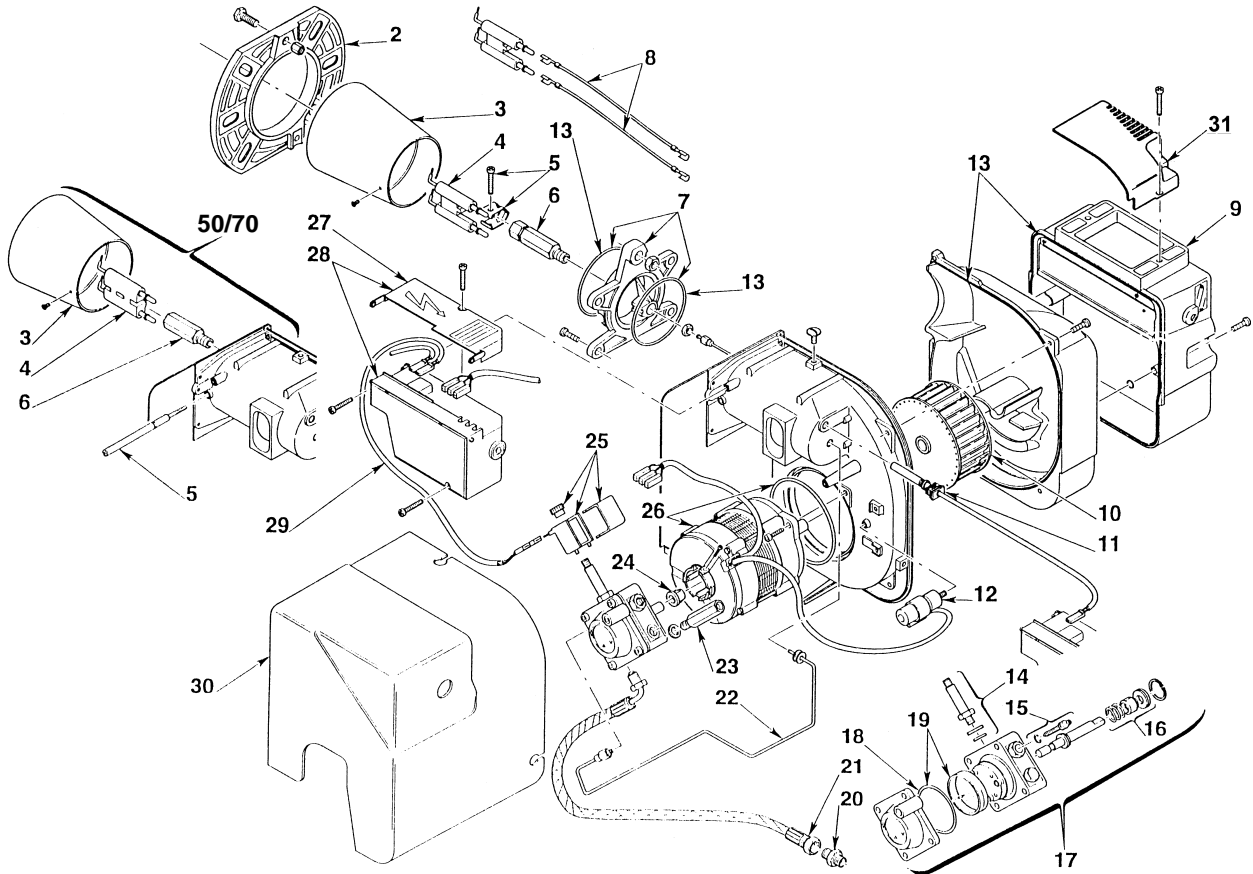

Key No.	Description	Riello Part No.	Grant Part No.	Key No.	Description	Riello Part No.	Grant Part No.
1	Not applicable	-	-	13	Seal kit	3008878	RBS140
2	Flange	3005786	RBS28	14	Needle valve	3007582	RBS109
3	Burner head LD2SX (50/70)	3008859	RBS132	15	Regulator	3008651	RBS120
3	Burner head LD3 (70/90)	3008768	RBS127	16	Pump seal	3000439	RBS14
3	Burner head LD3A (90 - 140)	3008769	RBS128	17	Pump	3008654	RBS101
3	Burner head (RDB2.1) T3 (90 - 140)	3002447	RBS144	18	'O' ring	3007162	RBS08
4	Electrode assembly (50/70)	3008860	RBS133	19	Filter - 'O' ring	3008653	RBS122
4	Electrode assembly	3007513	RBS108	20	Connector	3003602	RBS35
5	Screw (50/70)	3008875	RBS137	21	Flexible pipe	3007672	RBS36
5	Electrode bracket	3006552	RBS29	22	Tube	3008644	RBS113
6	Nozzle holder (50/70)	3008861	RBS134	23	Pressure gauge connector	3008876	RBS138
6	Nozzle holder	3008642	RBS111	24	Drive coupling	3000443	RBS16
7	Collar (50/70)	3008862	RBS135	25	Solenoid	3008648	RBS117
7	Collar	3008643	RBS112	26	Motor	3002836	RBS102
8	High voltage lead	3008794	RBS129	27	Control box assembly	3008649	RBS118
9	Air damper assembly	3008647	RBS116	28	Solenoid lead	3008851	RBS139
10	Fan	3005708	RBS39	30	Cover	3008879	RBS141
10	Fan RDB2.1	3005788	RBS151	31	Air intake cover		RBS142
11	Photocell	3008646	RBS115				
12	Capacitor 4.5 µF	3002837	RBS149				



Under the Consumer Protection Act 1987 and Section 6 of the Health & Safety at Work Act 1974, we are required to provide information on substances hazardous to health (COSHH Regulations 1988).

Adhesives, sealants and paints used in the manufacture of the product are cured and present no known hazards when used in the manner for which they are intended.

The following other materials are present in the product:

Insulation materials

Material Types: Ceramic fibre board, mineral wool.

Description: Rigid board, slabs, sleeves, gaskets, ropes.

Known Hazards: May cause temporary irritation or rash to skin. High dust levels may irritate eyes and upper respiratory system.

Precautions: Avoid unnecessary or rough handling, or harsh abrasion of boards. Normal handling and use of material should not produce high dust levels.
Avoid inhalation, and contact with skin and eyes.
After handling always follow normal good hygiene practices.

Protection: Use disposable gloves, face mask and eye protection.

First Aid: Eyes - If irritation occurs, wash eyes with copious amounts of water. If symptoms persist, seek immediate medical advice.
Skin - If irritation occurs, wash under running water before washing with soap and water.
Inhalation - Remove to fresh air, drink water to clear throat and blow nose to remove dust/fibres.
Ingestion - Drink plenty of water.

Sealants

Material Types: Silicone elastomer.

Description: Sealant and adhesive.

Known Hazards: Irritation to eyes.

Precautions: Avoid inhalation of vapour, contact with eyes and prolonged or repeated contact with skin.
After handling always follow normal good hygiene practices.

Protection: Use eye protection. Rubber or plastic gloves should be worn where repeated contact occurs and a face mask worn when working in confined spaces.

First Aid: Eyes - Flush eyes with water for 15 minutes. Seek immediate medical attention.
Skin - Wipe off and wash with soap and water.
Inhalation - Remove to fresh air.

Kerosene and Gas oil fuels (Mineral oils)

Known Hazards: The effect of mineral oils on the skin vary according to the duration of exposure and the type of oil. The lighter fractions remove the protective grease naturally present on the skin, leaving it dry, liable to crack and more prone to damage by cuts, abrasions and irritant chemicals.
Skin rashes (Oil acne) most often on arms, but also on any part of the body in contact with oil or oily clothing.
Contact with fuel oils can cause dermatitis.

Precautions: Avoid as far as possible any skin contact with mineral oil or with clothing contaminated with mineral oil.
The use of a lanolin-based barrier cream is recommended, in conjunction with regular washing with soap and rinsing with water to ensure all oil is removed from the skin.
Take care to prevent clothing, especially underwear, from becoming contaminated with oil.
Do not put oily rags or tools in pockets, especially trouser pockets.
Have first-aid treatment at once for an injury, however slight.
Do not inhale any vapours from mineral oils.

13 - EC DECLARATION OF CONFORMITY

We declare that the Outdoor range of Oil Boilers equipped with Riello RDB burner approved to EN 267: 1991 satisfy the requirements of the following European Directives:-

1. 89/336/EEC - Electromagnetic Compatibility Directive
Referred to the generic standards EN 55014: 1993, EN 50082: 1: 1992
2. 73/23/EEC - Electrical Equipment Safety Regulations Directive
Referred to the generic standard NO: 3260: The Electrical Equipment (Safety) Regulations: 1994
3. 92/42/EEC - Hot Water Boiler Efficiency Directive
Referred to the generic standard The Boiler (Efficiency) (Amendment) Regulations 1994
(SI 1994/3083)

OFCERT Licence Numbers:-

50/70 Outdoor Module 002079614
70/90 Outdoor Module 002029604

SEDBUK Ratings:-

50/70 Outdoor Module 85.3%
70/90 Outdoor Module 85.3%
90/120 Outdoor Module 85.2%
110/140 Outdoor Module 85.7%*
SEDBUK efficiency capped at 85.7%

Complies with the EC Low voltage,
Electromagnetic compatibility and
Boiler efficiency Directives



89/336/EEC
73/23/EEC
92/42/EEC

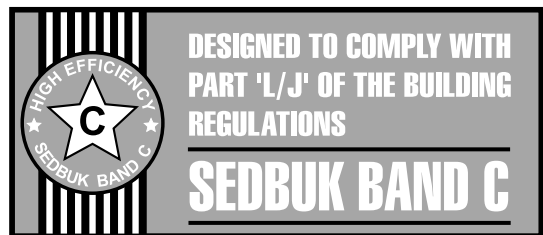

GRANT UK

Grant Engineering (UK) Limited

Hopton House, Hopton Industrial Estate, Devizes, Wiltshire SN10 2EU
Telephone: (0870) 7775553 Fax: (0870) 7775559
email: info@grantuk.com website: www.grantuk.com

This manual is accurate at the date of printing but will be superseded and should be disregarded if specifications and/or appearances are changed in the interests of continued product improvement.

All goods sold are subject to our official Conditions of Sale, a copy of which may be obtained on application.

© Grant Engineering (UK) Limited 2004. No part of this manual may be reproduced by any means without prior written consent.

Manual compiled and designed by Publications 2000 Tel: (01670) 356211