

# Installation, Operation and Maintenance Manual Oil Fired Warm Air Furnaces

## HML-C (Up-Flow Model) HMLV-C (Up-Flow Model with ECM)

ALL INSTALLATIONS MUST MEET ALL  
LOCAL, PROVINCIAL/STATE, AND  
FEDERAL CODES WHICH MAY  
DIFFER FROM THIS MANUAL

**Olsen**  
*Heating & Cooling Products*

**Airco**  
*Heating & Cooling Products*

**ECR International Limited**

Read this complete manual before  
beginning installation. These instructions  
must be kept with the furnace for future  
reference



## TABLE OF CONTENTS

1. INTRODUCTION .....	3
2. HEAT LOSS .....	3
3. LOCATION OF UNIT.....	3
4. AIR CONDITIONING APPLICATIONS .....	3
5. COMBUSTION AIR .....	4
6. CHIMNEY VENTING .....	4
7. BAROMETRIC DAMPER CONTROL.....	4
8. OPTIONAL SIDE WALL VENTING.....	5
9a, 9b. FAN TIMER BOARD AND LIMIT CONTROL (FIGURE 4 AND 5) .....	5
10. ELECTRICAL CONNECTIONS.....	5
11. HUMIDIFIER.....	6
12. PIPING INSTALLATION .....	6
13. OIL FILTER .....	6
14. OIL BURNER NOZZLES.....	6
15. OIL BURNER ADJUSTMENT .....	6
16. BURNER ELECTRODES.....	6
17. BURNER PRIMARY (SAFETY) CONTROL.....	7
18. COMBUSTION CHAMBER.....	7
19a, 19b. CIRCULATING AIR BLOWER.....	7
20. MAINTENANCE AND SERVICE.....	7
21. OPERATING INSTRUCTIONS.....	8
22. ECM BLOWER MOTOR OPERATION.....	9
APPENDIX A- HML-C AND HMLV-C .....	10
A.1 OIL BURNER AIR ADJUSTMENT .....	11
A.2 BURNER ELECTRODES .....	12
A.3 START UP .....	12
A.4 SPECIAL INSTRUCTIONS FOR UNITS EQUIPPED WITH RIELLO BURNERS.....	12
APPENDIX B: WIRING DIAGRAMS.....	16
OPERATION OF OIL BURNER .....	18
APPENDIX C OIL PRIMARY CONTROL DETAILED SEQUENCE OF OPERATION .....	19
OIL PRIMARY CONTROL LED DIAGNOSTIC LIGHT .....	23
FINAL CHECK OUT .....	29
HOMEOWNER'S REFERENCE TABLE.....	30
PARTS LISTING: HIGHBOY MODEL: HML – 80C AND HMLV-80C .....	31
NOTES: .....	34

## IMPORTANT:

### SAVE THESE INSTRUCTIONS FOR FUTURE REFERENCE

#### 1. INTRODUCTION

Please read these instructions completely and carefully before installing and operating the furnace.

#### MODELS HML-C AND HMLV-C

Models HML-C and HMLV-C are oil fired forced air up-flow furnaces with an output capacity range of 56,000 BTU/Hr. to 95,000 BTU/Hr.

#### **CAUTION**

**DO NOT USE GASOLINE, CRANK CASE OIL, OR ANY OIL CONTAINING GASOLINE.**

All models are CSA listed, (NRTL/C) for use with No. 1 (Stove) and No. 2 (Furnace) Oil. Please refer to the tables in Appendix A for performance and dimensional data.

In Canada, the installation of the furnace and related equipment shall be installed in accordance with the regulations of CAN/CSA - B139, *Installation Code for Oil-Burning Equipment*, as well as in accordance with local codes.

In the United States of America, the installation of the furnace and related equipment shall be installed in accordance with the regulations of NFPA No. 31, *Standard for the Installation of Oil-Burning Equipment*, as well as in accordance with local codes.

Regulations prescribed in the National Codes and Local regulations take precedence over the general instructions provided on this installation manual. When in doubt, please consult your local authorities.

All models are shipped assembled and pre-wired. The furnace should be carefully inspected for damage when being unpacked.

#### 2. HEAT LOSS

The maximum hourly heat loss for each heated space shall be calculated in accordance with the procedures described in the manuals of the Heating, Refrigeration and Air Conditioning Institute of Canada (HRAI), or by other means prescribed, or approved by the local authority having jurisdiction.

In the United States, Manual J, titled, "Load Calculation" published by the Air Conditioning Contractors of America, describes a suitable procedure for calculating the maximum hourly heat loss.

#### 3. LOCATION OF UNIT

The furnace should be located such that the flue connection to the chimney is short, direct and consists of as few elbows as possible. When possible, the unit

should be centralized with respect to the supply and return air ductwork. A central location minimizes the trunk duct sizing. All models may be installed on combustible floors.

The minimum installation clearances are listed in Table 1.

**Table 1: Clearances – (Inches)**

Location	Clearance to Combustibles
	HML-C and HMLV-C
	Up flow
Top	1
Bottom	0
S/A Plenum	1
Rear	1
Sides	1
Front	1**
Flue Pipe	9*
Enclosure	Closest

\*18 in. in USA

\*\* 24 in. required for service clearance

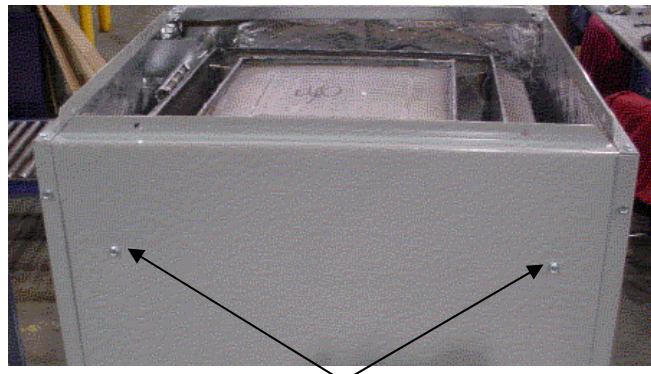

#### HEAT EXCHANGER SUPPORT SCREWS

Before final placement of the furnace, the heat exchanger support screws shown in the picture may be removed. This may be preferable if the furnace rear panel will be inaccessible after installation. The screws must be removed if the heat exchanger must be removed from the cabinet.

#### 4. AIR CONDITIONING APPLICATIONS

If the furnace is used in conjunction with air conditioning, the furnace shall be installed in parallel with or upstream from the evaporator coil to avoid condensation in the heat exchanger. In a parallel

installation, the dampers or air controlling means must prevent chilled air from entering the furnace. If the dampers are manually operated, there must be a means of control to prevent the operation of either system unless the dampers are in the full heat or full cool position. The air heated by the furnace shall not pass through a refrigeration unit unless the unit is specifically approved for such service.

The blower speed must be checked and adjusted to compensate for the pressure drop caused by the evaporator coil. Refer to Appendix B for recommended wiring and electrical connections of the air conditioning controls.

## 5. COMBUSTION AIR

If the furnace is installed in a closet or utility room, two openings must be provided connecting to a well-ventilated space (full basement, living room or other room opening thereto, but not a bedroom or bathroom). One opening shall be located above the level of the upper vent opening and one opening below the combustion air inlet opening in the front of the furnace. Each opening shall have a minimum free area of 1½ square inches per 1,000 Btu/h of total input rating of all appliances installed in the room.

For furnaces located in buildings of unusually tight construction, such as those with high quality weather stripping, caulking, windows and doors, or storm sashed windows, or where basement windows are well sealed, a permanent opening communicating with a well ventilated attic or with the outdoors shall be provided, using a duct if necessary. The duct opening shall have a free area of 1½ square inches per 1,000 Btu/h of total input rating of all appliances to be installed. When a furnace is installed in a full basement, infiltration is normally adequate to provide air for combustion and draft operation. Furnace rooms under 65m³ (700 ft³) should automatically be treated as confined space.

## 6. CHIMNEY VENTING

The flue pipe should be as short as possible with horizontal pipes sloping upward toward the chimney at a rate of one-quarter inch to the foot. The flue pipe should not be smaller in cross sectional area than the flue collar on the furnace. The flue pipe should connect to the chimney such that the flue pipe extends into, and terminates flush with the inside surface of the chimney liner. Seal the joint between the pipe and the lining. The chimney outlet should be at least two feet above the highest point of a peaked roof. All unused chimney openings should be closed. Chimneys must conform to local, provincial or state codes, or in the absence of local regulations, to the requirements of the National Building Code.

**NOTE: THE FURNACE IS APPROVED FOR USE WITH TYPE L VENT OR EQUIVALENT.**

### **CAUTION**

**CHIMNEY VENTED VERSIONS OF THE FURNACE MUST BE CONNECTED TO A FLUE HAVING SUFFICIENT DRAFT AT ALL TIMES TO ENSURE SAFE AND PROPER OPERATION OF THE APPLIANCE.**

**NOTE: THE RECOMMENDED FLUE DRAFT PRESSURE IS -0.02 IN. W.C. (SEE FIG 2.)**

The flue pipe must not pass through any floor or ceiling, but may pass through a wall where suitable fire protection provisions have been installed. Refer to the latest edition of CAN/CSA B-139 for rules governing the installation of oil burning equipment. In the United States, refer to the latest edition of NFPA 31 for regulations governing the installation of oil burning equipment.

See appendix A for burner set-up.

**Fig. 2: Checking Over-Fire Draft.**



**Over-fire draft access port.**

## 7. BAROMETRIC DAMPER CONTROL.

The barometric damper control, also known as a draft regulator, is used on conventional chimney venting only. This control automatically maintains a constant negative pressure in the furnace to obtain maximum efficiency. It ensures that proper pressures are not exceeded. If the chimney does not develop sufficient draft, the draft control cannot function properly. The draft regulator, when installed should be in the same room or enclosure as the furnace and should not interfere with the combustion air supplied to the burner. The control should also be located near the furnace flue outlet and installed according to the instructions supplied with the

**CHART 1**

**United Technologies 1158-120 (HML-C)**

regulator. The flue outlet pressure (measured between the furnace and draft regulator, or the oil burner mounting plate over-fired draft access port. fig. 2) should be set to -0.02 in. w.c.

**8. OPTIONAL SIDE WALL VENTING**

Certain HML-C and HMLV-C furnace models are manufactured to be installed as sidewall vented units. Please refer to Direct Venting Instructions, P/N 240006979 included with the Vent Kit for details. Sidewall Venting (*Direct Venting*) requires the use of specific oil burners; the Beckett AFII, or the Riello 40BF. Please refer to Appendix A, Tables A2, and A4.

Note: Sidewall venting requires special attention to combustion air supply. There is no natural draft in the venting system between furnace cycles; therefore, if the indoor pressure is negative relative to the outdoors, the vent terminal becomes a point of infiltration. This could lead to oil odour control problems. This problem is rectified by the use of ducted outdoor air for combustion (semi-sealed combustion), using the Beckett AFII or Riello 40BF oil burner. See Direct Vent Instructions supplied with the Vent Kits.

**9a. FAN TIMER BOARD AND LIMIT CONTROL (FIG. 4) (page 22)**

The Electronic Fan Timer integrates control of all burner and circulator fan operations. This control is the central wiring point for most of the electrical components in the furnace. The **United Technologies 1158-120 (HML-C)** has an adjustable fan on time that is set by selecting the dipswitch combination displayed in Chart 1. This fan on delay can be set at 1, 2, 4 or 6 minutes. This provides a delay between the burner ignition and blower start-up to eliminate excessive flow of cold air when the blower comes on. The **United Technologies 1158-120 (HML-C)** has an adjustable fan off time of 30, 60, 90 or 120 seconds displayed in Chart 1. The fan off delay time starts when the burner motor is de-energized at the end of a call for heat. Blower shutdown is delayed to remove any residual heat from the heat exchanger and improve the annual efficiency of the furnace.

The electronic fan timer board works in conjunction with snap disc limit controls, which perform a safety function, and breaks power to the oil burner primary control, which shuts off the burner if the furnace over-heats. The limit control is thermally operated and automatically resets. The limit control is factory installed, pre-set and is not adjustable.

If the limit control opens with the **United Technologies 1158-120 (HML-C)** electronic fan control, the circulating fan will be energized as well. When the limit closes, the fan off timer will begin. At the end of the fan off time cycle the burner will be energized, initiating a normal burner cycle.

Dip Switch Position				Blower Delay Times	
1	2	3	4	On Seconds	Off Minutes
Off	Off			30	
On	Off			60	
Off	On			90	
On	On			120	
		Off	Off		1
		On	Off		2
		Off	On		4
		On	On		6

**9b. FAN TIMER BOARD AND LIMIT CONTROL (FIG. 5) (page 22)**

The **United Technologies 1168-1 ECM (HMLV-C)** tap board has an adjustable fan on/off delay that must be adjusted in accordance with the furnace input rating (nozzle size). Refer to Table A-10 (pg 15) for ECM blower set-up.

**10. ELECTRICAL CONNECTIONS**

The furnace is listed by the Canadian Standards Association under the NRTL (North American) Standard. It is factory wired and requires minimal field wiring. All field wiring should conform to CAN/CSA C22.1 Canadian Electrical Code, Part 1, and by local codes, where they prevail. In the United States, the wiring must be in accordance with the National Fire Protection Association NFPA-70, National Electrical Code, and with local codes and regulations.

The furnace should be wired to a separate and dedicated circuit in the main electrical panel; however, accessory equipment such as electronic air cleaners and humidifiers may be included on the furnace circuit. Although a suitably located circuit breaker can be used as a service switch, a separate service switch is advisable. The service switch is necessary if reaching the circuit breaker involves becoming close to the furnace, or if the furnace is located between the circuit breaker and the means of entry to the furnace room. The furnace switch (service switch) should be clearly marked, installed in an easily accessible area between the furnace and furnace room entry, and be located in such a manner to reduce the likelihood that it would be mistaken as a light switch or similar device.

The power requirement for the HML-C and HMLV-C models is: 120 VAC, 1 Ø, 60 Hz., 12A.

Accessories requiring 120 VAC power sources such as electronic air cleaners and humidifier

transformers may be powered from the electronic fan timer board where provisions have been made for connections, but should have their own controls. Do not use the direct drive motor connections as a power source, since there is a high risk of damaging the accessories by exposure to high voltage from the auto-generating windings of the direct drive motor.

Thermostat wiring connections and air conditioning contactor low voltage connections are shown in the wiring diagrams in Appendix B. Some micro-electronic thermostats require additional controls and wiring. Refer to the thermostat manufacturer's instructions.

The thermostat should be located approximately 5 feet above the floor, on an inside wall where there is good natural air circulation, and where the thermostat will be exposed to average room temperatures. Avoid locations where the thermostat will be exposed to cold drafts, heat from nearby lamps and appliances, exposure to sunlight, heat from inside wall stacks, etc.

The thermostat heat anticipator should be adjusted to the amperage draw of the heating control circuit as measured at the "R" and "W" terminals of the thermostat. To reduce the risk of damaging the heat anticipator, do not measure this current with the thermostat connected to the circuit. Measure the amperage by connecting an ammeter between the two wires that will connect to the thermostat "R" and "W" terminals.

### 11. HUMIDIFIER

A humidifier is an optional accessory available through most heating supplies outlets. Installation should be carried out in accordance with the humidifier manufacturer's installation instructions. Water or water droplets from the humidifier should not be allowed to come into contact with the furnace heat exchanger. Do not use direct drive motor connections as a source of power for 120 VAC humidifiers and humidifier transformers.

### 12. PIPING INSTALLATION

The entire fuel system should be installed in accordance with the requirement of CAN/CSA B-139, and local regulations. Use only an approved fuel oil tanks piping, fittings and oil filter.

In the United States the installation must be in accordance with NFPA No. 31 and local codes and authorities.

Install the oil filter as close to the burner as possible. For further details of the oil supply tank and piping requirements, please refer to the instructions and illustrations in the oil burner and oil pump instructions shipped with the furnace.

### 13. OIL FILTER

All fuel systems should include an oil filter between the fuel oil storage tank and the oil burner. When using an oil

burner nozzle smaller than 0.65 U.S. Gallons Per Hour, install an additional 7 to 10 micron filter as close as possible to the oil burner.

### 14. OIL BURNER NOZZLES

The HML-C and HMLV-C are certified for multiple firing rates, ranging from 56,000 to 95,000 Btu/h. By manipulating the oil burner nozzle, flame retention head, static plate and temperature rise; the furnace may be fired at an ideal rate for a wide range of structures. Refer to Table A-1, and the furnace rating plate to determine the proper combinations.

### 15. OIL BURNER ADJUSTMENT

The burner air supply is adjusted to maintain the *fuel to air ratio* to obtain ideal combustion conditions. A lack of air causes "soft" and "sooty" flames, resulting in soot build-up throughout the heat exchanger passages. Excess combustion air causes a bright roaring fire and high stack temperatures resulting in poor fuel efficiency. The HML-C and HMLV-C furnaces operate most efficiently with a No. 1 smoke spot on the Bacharach Scale. This is not necessarily the optimum setting; however, because dust will inevitably build up on the air moving components of the oil burner assembly. This will result in decreased air supply with the potential result of soot building up in the flue gas passageways of the heat exchanger. Soot behaves as an insulator and impairs good heat transfer. Stack temperature will increase, and the overall efficiency will decrease. As a means of avoiding this problem, it is advisable to adjust the air supply to provide no more than a trace smoke spot on the Bacharach Scale.

See the Venting Instructions included in the Vent Kits for set-up details for sidewall vented furnaces.

**NOTE: SIDEWALL VENTED MODELS SHOULD BE SET UP TO DELIVER ZERO (0) SMOKE.**

<p><b>▲ CAUTION</b></p> <p><b>BEFORE OPERATING THE FURNACE CHECK BURNER ALIGNMENT WITH COMBUSTION CHAMBER. THE END CONE OF THE AIR TUBE MUST BE CENTRED TO THE ACCOMODATING RING PROVIDED IN THE DESIGN OF THE COMBUSTION CHAMBER. ADJUST AS NECESSARY.</b></p>
---

### 16. BURNER ELECTRODES

Correct positioning of the electrode tips with respect to each other, to the fuel oil nozzle, and to the rest of the burners is essential for smooth light ups and proper operation. Refer to the oil burner instructions shipped with the furnace for electrode specifications.

NOTE: Beckett AF Series Burner electrode specifications have been revised. They should be adjusted to be 5/16" above the nozzle centerline.

## 17. BURNER PRIMARY (SAFETY) CONTROL

The furnace is equipped with a primary combustion control, sometimes referred to as the burner relay or burner protector relay, which uses a light sensing device (cad cell) located in the burner housing, to monitor and control combustion. Over time, dust or combustion residuals can build up on the lens of the cad cell impairing its response to the flame. The cad cell should be checked for cleanliness and proper alignment if the primary control frequently shuts down combustion.

### **▲ CAUTION**

**ALL FURNACE CONTROLS ARE SENSITIVE AND SHOULD NOT BE SUBJECTED TO TAMPERING. IF PROBLEMS PERSIST, CALL YOUR SERVICE CONTRACTOR.**

## 18. COMBUSTION CHAMBER

This furnace is equipped with a high quality cerafelt combustion chamber. It is held in place by a retaining bracket.

**CHECK THE ALIGNMENT OF THE COMBUSTION CHAMBER AND OIL BURNER BEFORE FIRING. IT IS POSSIBLE FOR THE COMBUSTION CHAMBER TO SHIFT IF SUBJECTED TO ROUGH HANDLING DURING TRANSIT.** The combustion chamber should be inspected for damage or carbon build up whenever the oil burner is removed for repairs or routine maintenance.

### **▲ CAUTION**

**DO NOT START THE BURNER UNLESS THE BLOWER ACCESS DOOR IS SECURED IN PLACE.**

## 19a. CIRCULATING AIR BLOWER (HML-C)

The HML-C and HMLV-C furnace models are equipped with direct drive blower systems. HML-C models are equipped with PSC motors; HMLV-C models are equipped with electronically commutated motors (ECM). Direct drive blower speed adjustments are not normally required in properly sized extended plenum duct systems. The motor RPM and air CFM delivery will vary automatically to accommodate conditions within the usual range of external static pressures typical of residential duct systems. Under-sized duct systems may require a higher blower speed to obtain a reasonable system temperature rise. Some older duct systems were not designed to provide static pressure. They typically feature special reducing fittings at each branch run and

lack block ends on the trunk ducts. These systems may require modification to provide some resistance to the airflow to prevent over-amping of the direct drive blower motor. Selecting a lower blower speed may correct this problem. Direct drive blower speeds are adjusted by changing the "hot" wires to the motor winding connections. Please refer to wiring diagrams in Appendix B or the wiring diagram label affixed to the furnace. **THE NEUTRAL WIRE (normally the white wire) IS NEVER MOVED TO ADJUST THE BLOWER SPEED.**

It is possible and acceptable to use a single blower speed for both heating and cooling modes. The simplest method to connect the wiring from both modes is to use a "piggy-back connector" accommodating both wires on a single motor tap. It is also acceptable to connect the selected motor speed with a pigtail joined to both heating and cooling speed wires with a wire nut. As a safety precaution against accidental disconnection of the wires by vibration, it is advisable to secure the wire nut and wires with a few wraps of electricians tape.

### **▲ CAUTION**

**DO NOT CONNECT POWER LEADS BETWEEN MOTOR SPEEDS. THE NEUTRAL WIRE MUST ALWAYS BE CONNECTED TO THE MOTOR'S DESIGNATED NEUTRAL TERMINAL.**

If the joining of the blower speed wiring is done in the furnace junction box, tape off both ends of the unused wire.

**Do not use the blower speed wires as a source of power to accessories as electronic air cleaners and humidifier transformers.** The unused motor taps auto-generate sufficiently high voltages to damage accessory equipment.

### **▲ WARNING**

**DISCONNECT THE POWER SUPPLY TO THE FURNACE BEFORE OPENING THE BLOWER ACCESS DOOR TO SERVICE THE AIR FILTER, FAN AND MOTOR. FAILURE TO SHUT OFF POWER COULD ALLOW THE BLOWER TO START UNEXPECTEDLY, CREATING A RISK OF DEATH OR PERSONAL INJURY.**

## 19b. CIRCULATING AIR BLOWER (HMLV-C) (See Section 22 Page 9)

## 20. MAINTENANCE AND SERVICE

### Routine Maintenance By Home Owner

Other than remembering to arrange for the annual professional servicing of the furnace by the service or installation contractor, the most important routine service performed by the homeowner is to maintain the air filter or filters. A dirty filter can cause the furnace to over-heat, fail to maintain indoor temperature during cold weather, increase fuel consumption and cause component failure.

The furnace filter(s) should be inspected, cleaned or replaced monthly. The furnace is factory equipped with a semi-permanent type filter. If the filter is damaged, replace with filters of the same size and type. (See Appendix A, Table A-8).

During the routine service, inspect the general condition of the furnace watching for signs of oil leaks in the vicinity of the oil burner, soot forming on any external part of the furnace, soot forming around the joints in the vent pipe, etc. If any of these conditions are present, please advise your service or installation contractor.

### Annual Service By Contractor

#### **CAUTION**

**THE COMBUSTION CHAMBER (FIREPOT) IS FRAGILE. USE CARE WHEN INSPECTING AND CLEANING THIS AREA.**

The heat exchanger should be inspected periodically and cleaned if necessary. If cleaning is necessary, **SHUT OFF POWER TO THE FURNACE** and remove the burner. Using a stiff brush with a wire handle, brush off scale and soot from inside the drum and flue pipe. To clean the radiator, remove the clean-out caps screws, and remove the caps carefully to avoid tearing the gaskets. A wire brush can be used to loosen dirt and debris on the inside surfaces of the radiator. Clean out all accumulated dirt, soot and debris with a wire handled brush and an industrial vacuum cleaner. Before replacing the clean-out caps, inspect the gaskets. If the gaskets are broken, remove the remnants and replace with new gaskets.

The blower motor is factory oiled and permanently sealed. **DO NOT LUBRICATE.** Excess oil causes premature electric motor failure.

Inspect the blower fan. Clean if necessary.

Oil Burner Maintenance: Follow the instructions of the oil burner manufacturer. (See oil burner manufacturer's instructions supplied with furnace or burner). It is advisable to change the oil burner nozzle and oil filter on an annual basis.

The venting system should be cleaned and inspected for signs of deterioration. Replace pitted or perforated vent

pipe and fittings. The barometric damper should open and close freely.

All electrical connections should be checked to ensure tight connections. Safety controls such as the high limit controls should be tested for functionality. The fan control should be checked to ensure that the fan on and off delay function continues to start and stop the blower fan at the optimal settings.

## 21. OPERATING INSTRUCTIONS (HML-C)

### Before Lighting

Open all supply and return air registers and grilles.

Open all valves in oil pipes.

Turn on electric power supply

### To Light Unit

Set the thermostat above room temperature to call for heat. The burner should start. NOTE: It may be necessary to press the RESET button on the primary combustion control relay.

There will be a fan on time delay before the circulating fan is energized. The **United Technologies 1158-120** has an adjustable fan on time that is set by selecting the dipswitch combination displayed in Chart 1. This fan on delay can be set at 1, 2, 4 or 6 minutes.

Set the thermostat below room temperature. The oil burner should stop.

The air circulation blower will continue to run until the time off setting selected on the electronic fan timer control times out. The **United Technologies 1158-120** has an adjustable fan off time of 30, 60, 90 or 120 seconds. The fan timer control adjustments may be altered if the air at the room registers is uncomfortably high upon blower start up or shutdown.

The necessary adjustments to the fan control settings should be determined by measuring the temperature of the air in the supply air take-off, or within the first few inches of the supply air trunk. The side mid point of the transition is usually ideal, providing that the thermometer probe is beyond the "line of sight" wherein false readings from radiant heat could be observed. System temperature rise is *the difference in temperature between the supply air and return air.*

To check the operation of the limit switch, shut off power to the furnace. Temporarily remove the neutral wire from the direct drive blower motor. Restore the electrical power to the furnace and set the thermostat above room temperature.



After three or four minutes of burner operation, the limit control should turn the burner off. When the limit function test is complete, shut off electrical power to the furnace, replace the neutral wire to the blower fan motor, and then restore power. The blower fan will start up immediately. Once the temperature has dropped and the limit control has reset, the fan will operate until the fan off time is achieved. The oil burner will then resume operation and continue until the thermostat is satisfied. Restore the thermostat setting to a comfortable temperature.

#### To Shut Down Unit

Set the thermostat to the lowest possible setting.

Set the manual switch (if installed) in the Electrical Power Supply Line to "OFF".

### 21. OPERATING INSTRUCTIONS (HMLV-C)

#### Before Lighting

Open all supply and return air registers and grilles.

Open all valves in oil pipes.

Turn on electric power supply

#### To Light Unit

Set the thermostat above room temperature to call for heat. The burner should start. NOTE: It may be necessary to press the RESET button on the primary combustion control relay.

There will be a fan on time delay before the circulating fan is energized. The **United Technologies 1168-1** has an adjustable fan on/off time delay that is programmed into the ECM motor, and is set by selecting the SW4 DIP switch combination displayed in Table A-10 page 15.

**Fan on/off delay must be adjusted according to input (nozzle size).**

1. Set the thermostat below room temperature. The oil burner should stop.

The air circulation blower will continue to run until the blower off delay setting programmed into the ECM motor times out.

To check the operation of the limit switch, shut off power to the furnace. Temporarily remove the 5 pin power connector plug from the ECM blower motor. **NOTE: Isolate the AC Line pins on the 5 pin power connector with electrical tape to prevent electric shock hazard.** Restore the electrical power to the furnace and set the thermostat above room temperature.

After three or four minutes of burner operation, the limit control should turn the burner off. When the limit function test is complete, shut off electrical power to the furnace, replace the 5 pin power plug to the blower fan motor, and then restore power. The blower fan will start up immediately. Once the temperature has dropped and the limit control has reset, the fan will operate until the fan off time is achieved. The oil burner will then resume

operation and continue until the thermostat is satisfied. Restore the thermostat setting to a comfortable temperature.

**NOTE: IF THE FURNACE IS TO BE SHUT DOWN FOR AN EXTENDED PERIOD OF TIME, CLOSE THE OIL SUPPLY VALVE TO THE BURNER.**

#### **CAUTION**

**DO NOT ATTEMPT TO START THE BURNER WHEN EXCESS OIL HAS ACCUMULATED, WHEN THE FURNACE IS FULL OF VAPOUR, OR WHEN THE COMBUSTION CHAMBER IS VERY HOT. NEVER BURN GARBAGE OR PAPER IN THE FURNACE, AND NEVER LEAVE PAPER OR RAGS AROUND THE UNIT.**

### 22. ECM BLOWER MOTOR OPERATION (HMLV-C)

#### Setting Blower "ON" and "OFF" Timings

Blower on/off time delays are handled by ECM motor programming. Features of this ECM variable speed motor are that it will deliver a constant airflow within a wide range of external static pressures, and also includes:

**Soft Start:** This ECM variable speed motor will slowly ramp up to the required operating speed. This feature in the heating cycle allows the heat exchanger to reach operating temperature before the set heat speed, which minimizes noise and increases comfort.

**Soft Stop:** At the end of the heating cycle, the ECM variable speed motor will slowly ramp down. This feature allows for increased energy efficiency and reduced noise levels.

**Dehumidification:** A dehumidification feature has been programmed into the variable speed motor. At the start of each cooling cycle, the variable speed motor will run at 82% of the rated airflow for 7.5 minutes. After 7.5 minutes has elapsed, the motor will increase to 100% of the rated airflow. This profile is used to provide dehumidification and improve system efficiency.

**Continuous Fan Operation:** When the thermostat continuous fan (G) switch is on without a call for heating or cooling, the indoor fan is immediately energized up to 50% of the cooling speed. This feature allows continuous circulation of air between calls for heating or cooling.

If a call for heat (W) or cool (Y) occurs during continuous fan, the blower will remain energized

## Appendix A- HML-C AND HMLV-C

HML-C and HMLV-C furnaces may be used with the following oil burners.

Please note: The Beckett AF, and Riello 40F oil burners are for applications using indoor air for combustion only. For sidewall venting applications utilizing outdoor air for combustion, use the Beckett AFII or the Riello 40BF (Balanced Flue) oil burners only.

**Table A-1 Beckett AF Oil Burner Set-Up**

<b>Beckett AF Series Oil Burners</b> (For use with chimney vented units only)							
<b>Furnace Model</b>	<b>Output BTU/Hr</b>	<b>Burner Model</b>	<b>Nozzle</b>	<b>Pump Pressure</b>	<b>Flow Rate</b>	<b>Head <sup>1</sup></b>	<b>Static Plate</b>
HML-60C <sup>2</sup> HMLV-60C <sup>2</sup>	59,000	AF76BNHS	0.50 / 80°A	100 PSIG	0.50 USGPH	F3	3- 3/8 in.
HML-80C HMLV-80C	75,000	AF76BNHS	0.65 / 80°A	100 PSIG	0.65 USGPH	F3	3- 3/8 in.
HML-90C HMLV-90C	86,000	AF76BNHS	0.75 / 80°A	100 PSIG	0.75 USGPH	F3	3- 3/8 in.
HML-100C HMLV-100C	95,000	AF76BNHS	0.85 / 70°A	100 PSIG	0.85 USGPH	F3	3- 3/8 in.

<sup>1</sup> Head is shielded by ceramic insulator. <sup>2</sup> Low Firing Rate Baffle required when using a 0.50-gallon nozzle.

**Table A-2 Beckett AFII Oil Burner Set-Up**

<b>Beckett AFII Series Oil Burners</b> (For use with sidewall vented units with outdoor combustion air, or chimney vented units with indoor air for combustion)						
<b>Furnace Model</b>	<b>Output BTU/Hr</b>	<b>Burner Model</b>	<b>Nozzle</b>	<b>Pump Pressure</b>	<b>Flow Rate</b>	<b>Head</b>
HML-60CB2U HMLV-60CB2U	63,000	AFII-85	0.50 / 60°A	120 PSIG	0.55 USGPH	FB0
HML-80CB2U HMLV-80CB2U	75,000	AFII-85	0.60 / 60°A	115 PSIG	0.65 USGPH	FB3
HML-90CB2U HMLV-90CB2U	86,000	AFII-85	0.70 / 60°A	115 PSIG	0.75 USGPH	FB3

**Table A-3 Riello 40F Series Oil Burner Set-Up**

<b>Riello 40F Series Oil Burners</b> (For use with chimney vented units)							
<b>Furnace Model</b>	<b>Output BTU/Hr</b>	<b>Burner Model</b>	<b>Nozzle</b>	<b>Pump Pressure</b>	<b>Flow Rate</b>	<b>Air Gate</b>	<b>Turbulator Setting</b>
HML-60CRF HMLV-60CRF	59,000	40F3	0.50 / 60°W	105 PSIG	0.50 USGPH	2.6	1.0
HML-80CRF HMLV-80CRF	75,000	40F3	0.60 / 60°W	115 PSIG	0.65 USGPH	2.6	1.5
HML-90CRF HMLV-90CRF	86,000	40F3	0.65 / 60°W	135 PSIG	0.75 USGPH	3.6	2.0

<b>Riello Balanced Flue Series Oil Burners</b> (For use with sidewall vented units using outdoor combustion air)						
<b>Furnace Model</b>	<b>Output BTU/Hr</b>	<b>Burner Model</b>	<b>Nozzle</b>	<b>Pump Pressure</b>	<b>Flow Rate</b>	<b>Turbulator Setting</b>
HML-60CRBU HMLV-60CRBU	59,000	40BF3	0.50 / 60°W	105 PSIG	0.50 USGPH	1.0
HML-80CRBU HMLV-80CRBU	75,000	40BF3	0.60 / 60°W	115 PSIG	0.65 USGPH	1.5
HML-90CRBU HMLV-90CRBU	86,000	40BF3	0.65 / 60°W	135 PSIG	0.75 USGPH	2.0

**Table A-4 Riello Balanced Flue (BF) Burner Set-Up**

**NOTE:** Air gate setting may vary for sidewall vented units where air gate must be adjusted to achieve zero smoke.

**A.1 OIL BURNER AIR ADJUSTMENT**

For complete details, consult the oil burner instruction manual provided in the furnace documents envelope.

**Beckett AF Burner**

Adjust the air shutter by loosening the locking screws and moving the air shutter, and if necessary, the bulk air band.

**Beckett AFII Burner**

Adjust the burner air supply by first loosening the locking screw located on the black dial to the right of the burner. Turn the black dial clockwise to increase the combustion air and counter-clockwise to decrease the combustion air. Re-tighten the locking screw after obtaining the proper setting.

**Riello 40 Series (Chimney Vented)**

Riello burners are factory set with respect to nozzle size; pump pressure, air gate and turbulator

adjustments for each model and firing rate. By removing the burner cover and loosening the screws that secure the air adjustment plate, the combustion air can be adjusted. Move the adjusting plate to either increase or decrease combustion air. When the proper air setting is achieved, retighten the fixing screws.

**Riello Balanced Flue (BF) Series**

Riello burners are factory set with respect to nozzle size; pump pressure, and turbulator adjustments for each model and firing rate. The combustion air can be adjusted with the burner cover on by first removing the plastic cover on the top right hand side of the burner cover. With a Philips head screw driver, turn the adjustment screw clockwise to increase combustion air or counter-clockwise to decrease combustion air. When the combustion air is set, re-insert the plastic cover.

## A.2 BURNER ELECTRODES

Adjustment of the electrode tips with respect to each other, the nozzle, and to the rest of the burner is very important to ensure smooth start-ups and to permit efficient combustion.

### Beckett AF Burner

Electrode gap: 5/32 inch.

Distance above horizontal centerline: 5/16 inch. Older instruction sheets specify 7/16 inch. The current specification is 5/16 inch.

Distance ahead of nozzle: 1/16 inch.

"Z" dimension, the distance from the front of the end cone (head) to the face of the nozzle should be 1-1/8 inches. If a ceramic head is used, the distance from the end cone to the nozzle face is increased to 1-3/8 inches.

### Riello 40F, & BF Burners

Electrode gap: 5/32 inch.

Distance above horizontal centerline: 13/64 inch.

Distance ahead of nozzle: 5/64 to 7/64 inch.

## A.3 START UP

The furnace should be operated for a minimum of 10 minutes to reach steady state conditions before fine tuning combustion. The warm up time is ideal for testing the oil pump pressure.

Drill a 1/4-inch test port in the venting between the furnace flue outlet and draft regulator (barometric damper). Insert a stack thermometer and note the flue gas temperature. The flue gases should be within a range of 350°F to 450°F. If the flue gases are below the range, it may be necessary to slow down the blower fan. If the flue gases are above the range, the blower fan may require speeding up. Stack temperature varies directly with the system temperature rise. System temperature rise is the difference between the furnace outlet temperature and furnace inlet temperature as measured in the vicinity of the connection between the plenum take-offs and the trunk ducts. Temperature rise value is listed on the system rating plate.

Perform a smoke spot test. The smoke spot should not exceed No. 1 on the Bacharach Scale.

After the air adjustments have been completed, re-check the draft pressure at the test port on the burner mounting plate as shown in Figure 2. The draft should be adjusted to -0.02 inches w.c.

In the United States, the Beckett AF Burner may be equipped with Beckett's "*Inlet Air Shut-Off*" to increase efficiency. (Beckett Part No. AF/A 5861).

**NOTE: USE OF THE INLET AIR SHUT-OFF COULD CAUSE POST COMBUSTION NOZZLE DRIP.**

## A.4 SPECIAL INSTRUCTIONS FOR UNITS EQUIPPED WITH RIELLO BURNERS

Riello burners are factory set with respect to nozzle size, pump pressure, air gate and turbulator adjustments for each model and firing rate; therefore, do not use the above listed set up procedures.

Riello specifications are listed in Tables A-3 and A-4. Consult the Riello Installation Instructions supplied with the Burner for specific information concerning burner adjustments, operation, and trouble-shooting.

**Table A-6 Direct Drive Blower Set-Up PSC Motor**

Furnace Model	Blower	Blower Set-Up				Cooling Capacity		
		0.20 in. w.c.		0.50 in. w.c.		Tons	Power	CFM Range
		Speed	Motor	Speed	Motor			
HML-60C	100-10T DD	Low	1/2 HP	Med-Low	1/2 HP	3	1/2 HP	690 – 1500
HML-80C	100-10T DD	Med-Low	1/2 HP	Med-High	1/2 HP	3	1/2 HP	690 – 1500
HML-90C	100-10T DD	Med-High	1/2 HP	High	1/2 HP	3	1/2 HP	690 – 1500
HML-100C	100-10T DD	Med-High	1/2 HP	High	1/2 HP	3	1/2 HP	690 – 1500

**Table A-8 Direct Drive Blower Characteristics PSC Motor**

Furnace Model	Blower	Motor HP	Motor FLA	ΔT	Speed	CFM				
						External Static Pressure – Inches w.c.				
						0.20	0.30	0.40	0.50	0.60
HML-C 60 – 100	100-10T DD	1/2 HP	7.0	60°F	High	1741	1651	1556	1476	1369
					Med-High	1557	1497	1434	1369	1278
					Med-Low	1063	1051	1037	1037	1011
					Low	697	697	687	672	646

Furnace Model	Blower	Motor HP	Motor FLA	ΔT	CFM RANGE		
					Continuous Fan	Heating	Cooling
						0.38 - 0.48 inches w.c.	0.5 inches w.c.
HMLV-C 60 – 100	100-10T DD	1/2 HP ECM	7.7	60°F	445 - 605	625 - 1500	600 - 1200

**TIP:** These Formulae will assist with the design of the ductwork and the determination of airflow delivery:

$$CFM = \text{Bonnet Output} / (1.085 \times \text{System Temperature Rise } (\Delta T))$$

$$\text{System Temperature Rise } (\Delta T) = \text{Bonnet Output} / (1.085 \times CFM)$$

**Table A-9 General Dimensions (Inches)**

Furnace Model	Cabinet			Plenum Openings			Flue Diameter	Filter		Shipping Weight (LB.)
	Width	Depth	Height	Supply	Return			Type	Size	
					Side	Bottom				
HML-C HMLV-C	22	30-3/4	49-5/8	20½ x 20	14 x 22	14 x 22	5	Permanent	16 x 25 x 1	210

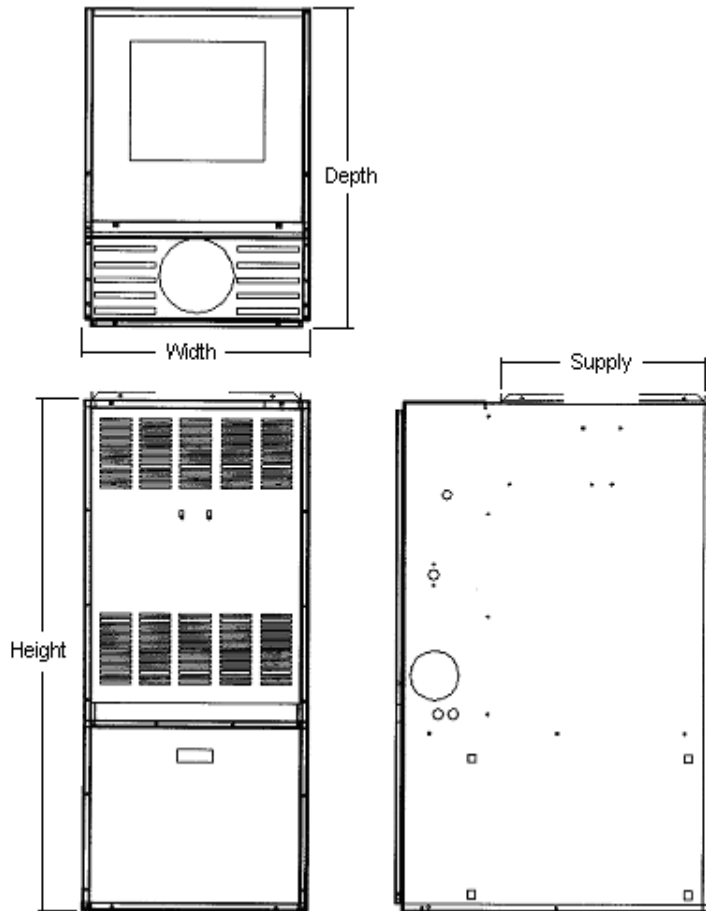

**Table A-10 ECM Blower Set-Up (HMLV-C)**

**DIP SWITCH ADJUSTMENT CHART**

FOR INPUT 0.50 USGPH TO 0.85 USGPH

SW1 - HEAT		POS.	INPUT USGPH
DIP Switch Position			
1	2		
OFF	OFF	A	0.65
ON	OFF	B	0.85
OFF	ON	C	0.75
ON	ON	D	0.50

SW2 - COOL		POS.	AC Size (TON)
DIP Switch Position			
1	2		
OFF	OFF	A	3
ON	OFF	B	2.5
OFF	ON	C	2
ON	ON	D	1.5

SW3 - ADJUST		POS.	CFM
DIP Switch Position			
1	2		
OFF	OFF	A	0%
ON	OFF	B	(+)15%
OFF	ON	C	(-)15%
ON	ON	D	N/A

SW4 - DELAY		POS.	INPUT USGPH
DIP Switch Position			
1	2		
OFF	OFF	A	0.65
ON	OFF	B	0.85
OFF	ON	C	0.75
ON	ON	D	0.50

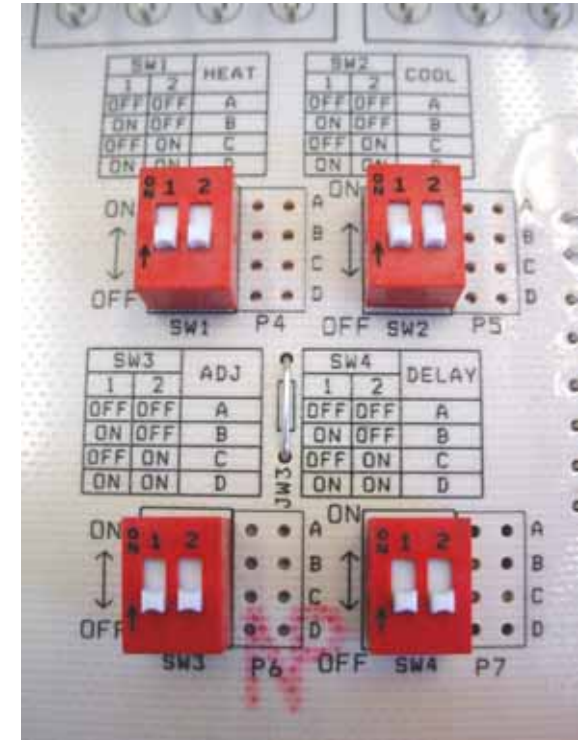

**NOTE:**

**SW1 (HEAT) AND SW4 (DELAY) DIP SWITCHES MUST BOTH BE ADJUSTED ACCORDING TO INPUT (NOZZLE SIZE).**

**SW2 (COOL): 1 TON is approximately equal to 400 CFM**

**SW3 (ADJUST): (Heating Mode) Increase OR decrease temperature rise respectively  
(Cooling Mode) Increase OR decrease CFM respectively**





# Direct Vent Burner Wiring Diagram HML-C HMLV-C

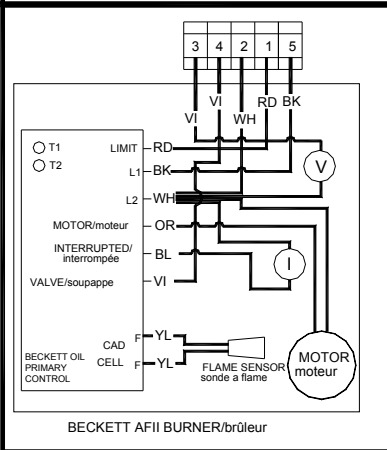
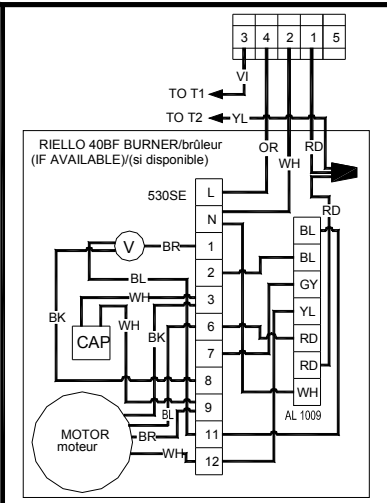
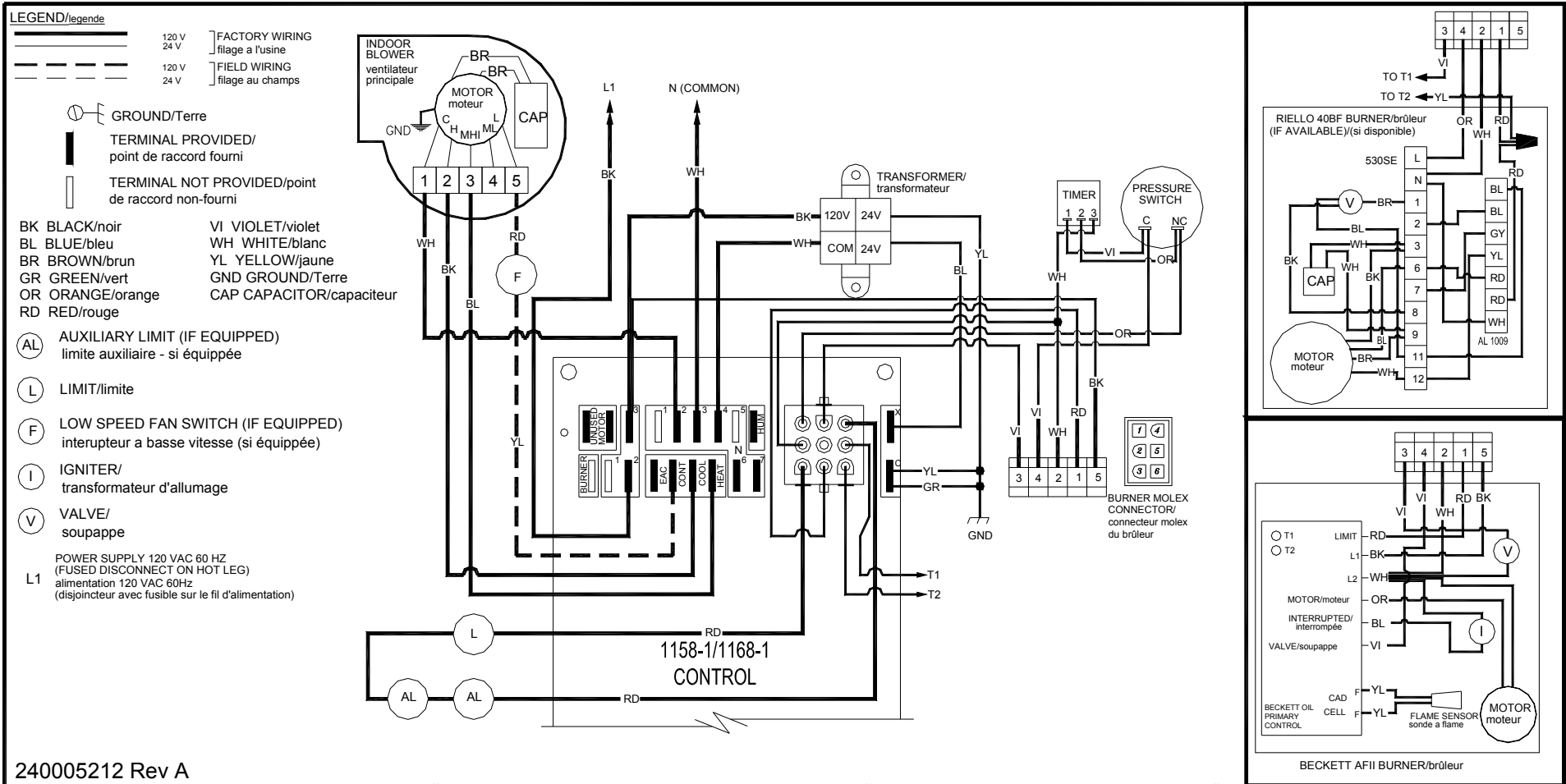

240005212 Rev A

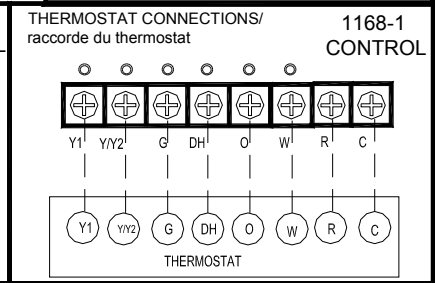
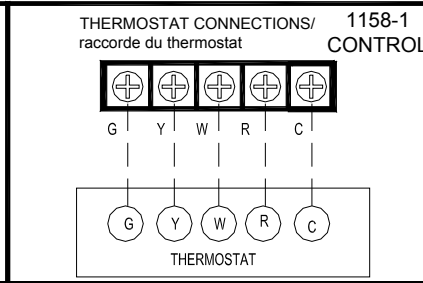
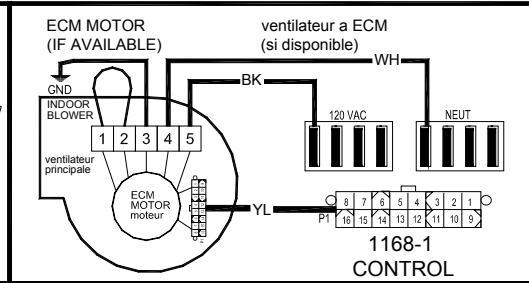
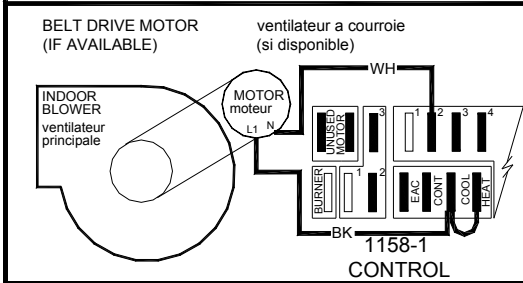

## OPERATION OF OIL BURNER

Once the furnace flue pipe, electrical and oil line connections have been made, use the following instructions to set the burner:

Shut off the electrical power to the furnace.

Install an oil pressure gauge to the pressure port on the oil pump. (Refer to the oil pump specification sheet included with the burner instructions).

Restore electrical power to the furnace.

Start the furnace and bleed all air from the fuel oil lines.

Close the purge valve and fire the unit.

Allow the furnace to warm up to normal operating temperatures. During this time, set the pump pressure in accordance with the data provided in Appendix A, Table A-2, and A-5.

When the furnace has reached "*steady state*" (after approximately 10 minutes). Set combustion air damper to get a TRACE of smoke.

Check the system temperature rise. *The temperature rise is the difference between the return air temperature measured at a point near the return air inlet, and the supply air temperature measured near the furnace outlet.* The system temperature rise is listed on the furnace rating plate. If the temperature rise is too high, the airflow must be increased. If the temperature rise is too low, the fan should be slowed down.

Turn off the burner. Observing the duct thermometer in the supply air stream, note the temperature at which the blower fan stops. The fan adjustments can be made by moving the dipswitch settings on the timer control board for fan off delay.

To check the operation of the limit switch, shut off power to the furnace. Temporarily remove the neutral wire from the direct drive blower motor. Restore the electrical power to the furnace and set the thermostat above room temperature. After three or four minutes of burner operation, the limit control should turn the burner off. When the limit function test is complete, shut off electrical power to the furnace, replace the neutral wire to the blower fan motor, and then restore power. The blower fan will start up immediately. Once the temperature has dropped and the limit control has reset, the fan will operate until the fan off time is achieved. The oil burner will then resume operation and continue until the thermostat is satisfied. Restore the thermostat setting to a comfortable temperature.

Set the heat anticipator adjustment in the thermostat (if so equipped), by removing the "R" or "W" wire to the thermostat, then reading the amperage draw between the two wires. Failure to remove one of the wires from the thermostat while performing this test could burn out

the heat anticipator. Set the heat anticipator to the amperage measured.

**NOTE: THE FURNACE SHOULD BE RUN THROUGH AT LEAST THREE FULL CYCLES BEFORE LEAVING THE INSTALLATION, TO ENSURE THAT ALL CONTROLS ARE OPERATING PROPERLY AND AS EXPECTED.**

**NOTE: ALL JOINTS IN ANY POSITIVE PRESSURE VENTING SYSTEM MUST BE CHECKED FOR LEAKS BEFORE LEAVING THE INSTALLATION SITE.**

---

## APPENDIX C OIL PRIMARY CONTROL DETAILED SEQUENCE OF OPERATION

Power is applied to unit. The oil primary control completes a self-diagnostic procedure. If no light or flame is present, and unit passes its self-diagnostic procedure, the control enters into the idle mode.

*Thermostat calls for heat:*

- A) Safety check is made for flame (4 second delay).
  - 1) If flame is not present, the oil primary control will apply power to the burner motor and igniter.
  - 2) If flame is present, the control remains in the idle state.
- B) Unit enters a pre-purge period of 15 seconds.
- C) After 10 seconds, control checks for flame presence.
  - 1) If flame is not present, the oil primary control enters the trial for ignition state.
  - 2) When flame is present, the control enters lock out mode.
- D) The Oil Primary Control monitors the burner flame.
  - 1) When flame is present, the control enters ignition carryover state. (Continues to spark for 10 sec.).
    - a) Provides continuous spark after flame is sensed to assure that burner remains lit.
    - b) Turns on LED diagnostic light.
    - c) Starts carryover timer.
      - (i) Flame and call for heat are monitored.
        - If flame is lost and lockout timer has not expired, the control will return to trial for ignition state.
        - If flame is lost and lockout timer has expired, the control will enter the recycle state.
          - ◆ Recycle timer starts.
          - ◆ Burner motor and igniter and solenoid valve are turned off.
          - ◆ LED diagnostic light flashes slowly.
- E) Carryover timer expires.
  - 1) Enters run state.
    - a) Igniter turns off.

*Combustion continues until thermostat is satisfied, or the oil primary control detects a loss of flame and enters into Recycle Mode.*

- F) Thermostat is satisfied - call for heat is terminated:
  - a) Oil primary control shuts off burner motor and solenoid valve.
    - (i) If the control utilizes a blower motor off delay, after 30 seconds, flame presence is checked.
      - If flame is not present, the control LED diagnostic light is off and returns to idle state.
      - If flame is presence is detected, the control enters lock out mode.

**FIGURE 4: UNITED TECHNOLOGIES 1158-120 FAN TIMER BOARD (HML-C)**

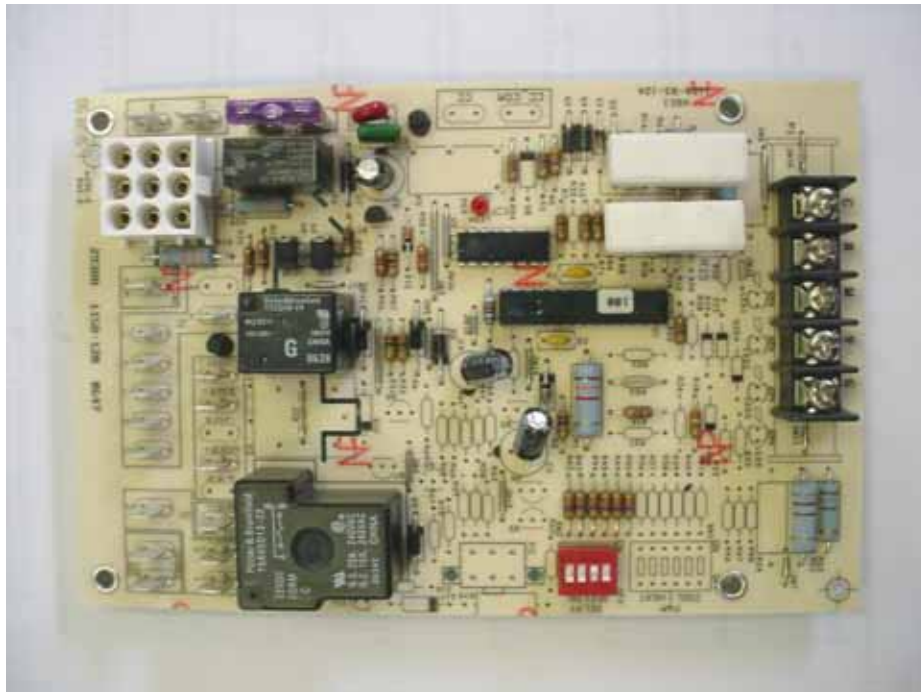

**FIGURE 5: UNITED TECHNOLOGIES 1168-1 ECM TAP BOARD (HMLV-C)**

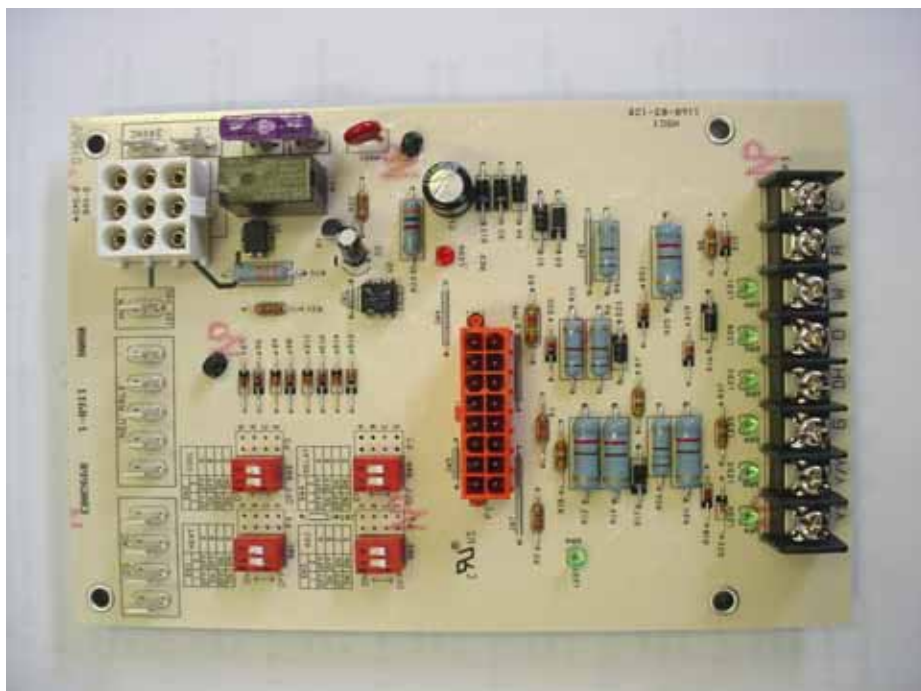

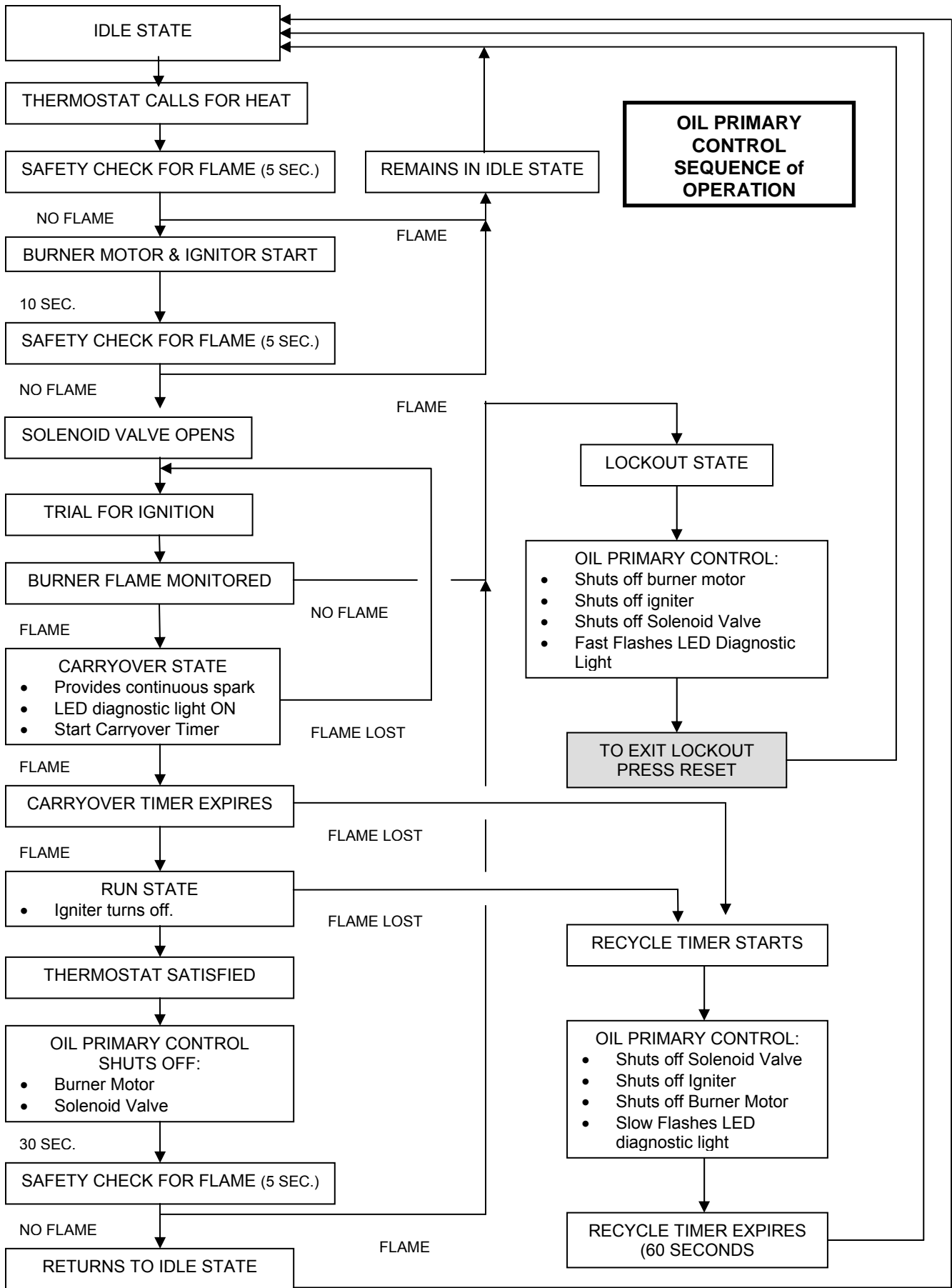

**Table C-1: 1158-120 ELECTRONIC FAN TIMER BOARD (EFT) DETAILED SEQUENCE OF OPERATION**

Mode	Action	System Response
HEAT	Thermostat calls for heat. ("W" terminal is energized).	EFT closes the oil primary control T - T connections). Ignition system and the oil primary control start the furnace. Oil flows as long as the oil primary control senses flame. Burner motor is energized and heat "fan on" delay timing begins. When timing is complete, the circulator fan is energized at heat speed.
	Thermostat ends call for heat. ("W" terminal is de-energized).	The oil primary control is de-energized, terminating the burner cycle. Heat "fan off" delay timing begins. Length of delay depends on EFT dipswitch settings. When timing is complete, the circulator fan is de-energized. EFT returns to standby mode, (Oil primary control and circulator fan are off, unless continuous fan operation is selected at the thermostat).
	Burner fails to light.	Oil primary control locks out within lockout timing, (30 seconds). Burner motor is de-energized. (Even though thermostat is still calling for heat). If circulator fan has started, it continues through the selected heat "fan off" delay period.
	Established flame fails.	Burner motor is de-energized and oil primary control goes into recycle mode. If the selected heat "fan off" delay timing is longer than the recycle delay timing, the circulator fan continues to run through the next trial for ignition.
COOL	Thermostat begins call for cool. (G and Y terminals are energized).	Cooling contactor is energized immediately. Circulator fan is energized at cool speed.
	Thermostat ends call for cool. (G and Y terminals are de-energized).	Cooling contactor is de-energized immediately. Circulator fan turns off immediately.
FAN	Thermostat begins call for fan. (G terminal is energized).	Circulator fan is energized immediately at cooling speed.
	Thermostat ends call for fan. (G terminal is de-energized).	Circulator fan is de-energized immediately.
LIMIT	Limit switch string opens.	Oil primary control shuts off burner. Circulator fan is energized immediately at heat speed. EFT opens the oil primary control T - T connections. Circulating fan runs as long as limit string stays open. If there is a call for cooling or fan, the circulating fan switches from heating to cooling speed.
	Limit switch string closes (with existing call for heat).	EFT begins heat "fan off" delay sequence. Circulating fan turns off after the selected heat "fan off" timing. EFT re-closes the oil primary control T - T connections. Oil primary control is energized, initiating burner light off.
	Limit switch string closes (without existing call for heat).	Circulator fan turns off when heat "fan off" delay time is complete. Normal operation resumes; EFT control is in standby mode awaiting next thermostat command.
FAN	Continuous circulating fan is connected.	Circulating fan is energized when there is no call for heat, cool, or fan. If fan operation is required by a call for heat, cool, or fan, the EFT switches off the continuous fan speed tap before energizing the other fan speed.
EAC	Electronic Air Cleaner is connected.	Electronic air cleaner (EAC) connections are energized when the heat or cool speed of the circulator fan is energized. EAC connections are not energized when the optional continuous fan terminal is energized.
HUM	Humidity control is connected.	Humidifier connections are energized when the oil burner motor is energized.

**1168-1 ELECTRONIC FAN TIMER BOARD (EFT) DETAILED SEQUENCE OF OPERATION**

**Thermostat Input LEDs (LED1-5, LED8)**

Six green LEDs are placed behind their respective thermostat connections (Y1, Y1/2, G, DH, O, and W) and operate whenever a call is present.

**Thermostat calls for heat "W"**. The 24VAC input signal is passed to pin 2 of P1 and will drive the K1 relay that provides dedicated contacts to the T-T input of the Oil Primary Control. **Thermostat calls for cool "Y1"**. The 24VAC input signal is passed to pin 6 of P1. **Thermostat calls for fan "G"**. The 24VAC input signal is passed to pin 15 of P1. **Thermostat calls for dehumidification "DH"**. The 24VAC input signal is passed to pin 10 of P1. **Thermostat calls for reversing valve "O"**. The 24VAC input signal is passed to pin 9 of P1.

## OIL PRIMARY CONTROL LED DIAGNOSTIC LIGHT

The LED diagnostic light has several functions. It indicates the state or mode in which the oil burner is operating. It will also indicate fault conditions, and help determine cad cell resistance while the burner is operating.

### NORMAL CONDITIONS:

The LED diagnostic light will turn on when the burner enters the carryover state; the point at which ignition spark is on, and will remain on through the run state, where the ignition spark is terminated but the burner continues to fire.

The LED diagnostic light will turn off at the end of the burner cycle as the oil primary control enters the idle state, and will remain off until the next heating cycle.

### FAULT CONDITIONS:

If the LED diagnostic light is flashing quickly; 1 Hz (½ second on / ½ second off), the oil primary control is in the lockout state or in restricted mode. To exit the lockout state, press the reset button.

If the LED diagnostic light is flashing slowly; ¼ Hz (2 seconds on / 2 seconds off), the oil primary control is in the recycle state. This indicates that flame sensing was lost after the lockout timer expired during the ignition carryover state. The oil primary control will return to the idle state within 60 seconds.

### CAD CELL CONDITION:

If the LED diagnostic light is off, the cad cell is not sensing flame.

If the LED diagnostic light is on, the cad cell is sensing flame, or viewing ambient light.

The resistance of the cad cell may be checked while the oil primary control is in the run state by pressing the reset button. The LED diagnostic light will flash the following code:

**Table C-2: Cad Cell Resistance**

Flashes	Resistance in Ohms
1	Less than 400
2	Between 400 - 800
3	Between 800 – 1600
4	Between 1600- 5000

## TROUBLESHOOTING

**IMPORTANT:** Due to the potential hazard of line voltage, only a trained, experienced service technician should perform the troubleshooting procedure.

### PRELIMINARY STEPS:

Check the diagnostic light for indications of burner condition. Refer to the oil primary control LED DIAGNOSTIC LIGHT section for details.

### **CAUTION**

**WHEN SIMULATING A CALL FOR HEAT AT THE OIL PRIMARY CONTROL, DISCONNECT AT LEAST ONE THERMOSTAT LEAD WIRE FROM THE T1 - T2 TERMINALS TO PREVENT DAMAGE TO THE THERMOSTAT. NEGLECTING THIS PROCEDURE MAY BURN OUT THE HEAT ANTICIPATOR OF A STANDARD 24 VAC THERMOSTAT, OR CAUSE HARM TO COMPONENTS WITHIN A MICRO-ELECTRONIC THERMOSTAT.**

Before checking the oil primary control, perform these preliminary checks, (repair or replace controls as necessary):

- Check the power supply; fuse box or breaker, any service switches, all wiring connections, and burner motor reset button (if equipped).
- Check the limit switches to ensure that the switch contacts are closed.
- Check the electrode gap and position.
- Check the contacts between the oil primary control and the electrodes.
- Check oil supply (tank gauge).
- Check the oil nozzle, oil filter, and oil valves.
- Check the piping or tubing to the oil tank.
- Check the oil pump pressure.

### CHECK OIL PRIMARY CONTROL AND IGNITER

If the trouble does not appear to be in the burner or ignition hardware, check the oil primary control and the igniter by using the following equipment:

Screwdriver.

Voltmeter (0 - 150 VAC)

Insulated jumper wires with both ends stripped.

**⚠ WARNING**

**ELECTRICAL SHOCK HAZARD.  
TROUBLESHOOTING IS DONE WITH THE  
SYSTEM POWERED. BE CAREFUL TO  
OBSERVE ALL NECESSARY PRECAUTIONS  
TO PREVENT ELECTRICAL SHOCK OR  
EQUIPMENT DAMAGE.**

**PRELIMINARY CHECKS:**

Make sure that limit switches are closed and those contacts are clean.

Check for line voltage power on the oil primary control black and white lead wires.

Refer to Table C-4 or C-5 for further troubleshooting information.

**Table C-3: Oil Primary Control TROUBLESHOOTING**

**Condition: Burner motor does not start when there is a call for heat.**

Procedure	Status	Corrective Action
1. Check that limit switches are closed and contacts are clean.	N/A	N/A
2. Check for line voltage power at the oil primary control. Voltage should be 120 Vac between the black and white lead wires on the oil primary control.	N/A	N/A
3. Check indicator light with burner off, no call for heat (no flame).	Indicator light is on.	Cad cell is defective, sees external light, or connections have shorted. Go to step 4.
	Indicator light is off.	Go to step 5.
4. Shield cad cell from external light.	Indicator light turns off.	Eliminate external light source or permanently shield cad cell.
	Indicator light stays on.	Replace cad cell with new cad cell and recheck. If indicator light does not turn off, remove yellow lead wires from oil primary control and recheck. If indicator light is still on, replace the oil primary control. If the indicator light turns off, replace cad cell bracket assembly.
5. Jumper thermostat (T -T) terminals on oil primary control  <b>IMPORTANT</b> First remove one thermostat lead wire.	Burner starts.	Trouble is in thermostat circuit. Check thermostat-wiring connections. If connections are clean and tight, check thermostat wires for continuity.
	Burner does not start.	Disconnect line voltage power and open line switch. Check all wiring connections. Tighten any loose connections and recheck. If burner still doesn't start, replace the oil primary control. If burner still doesn't start, check the oil burner motor. It may be seized or burned out.

**Condition: Burner starts then locks out on safety with indicator light flashing at 1 Hz rate (½ second on, ½ second off)**

Procedure	Status	Corrective Action
1. Check that the limit switches are closed and contacts are clean.	---	---
2. Check for line voltage power at the oil primary control. Voltage should be 120 Vac (nominal)	---	---
3. Check indicator light with burner off, no call for heat (no flame).	Indicator light is on.	Cad cell or controller is defective, sees external light, or connections are shorted. Go to step 4.
	Indicator light is off.	Go to step 5.



<b>Table C-3: Oil Primary Control Troubleshooting</b> <i>continued from previous page</i>		
<b>Procedure</b>	<b>Status</b>	<b>Corrective Action</b>
4. Shield cad cell from external light.	Indicator light turns off.	Eliminate external light source or permanently shield cad cell.
	Indicator light stays on.	Replace cad cell with new cad cell and recheck. If indicator light does not turn off, remove cad cell lead wires from oil primary control and recheck. If indicator light turns off, replace cad cell bracket assembly. If indicator light does not turn off, replace controller.
5. Jumper thermostat (T -T) terminals on oil primary control	Burner starts.	Trouble in thermostat or limit circuit. Check thermostat or limit wiring connections.
<b>IMPORTANT</b> First remove one thermostat lead wire.	Burner does not start.	Disconnect the line voltage power and open line switch. Check all wiring connections. Tighten any loose connections and recheck. If burner does not start, replace oil primary control

**Condition: Burner starts then locks out on safety with indicator light flashing at 1 Hz rate (½ second on, ½ second off)**

6. Reset oil primary control by pushing in and releasing red reset button.	Indicator light stops flashing.	Go to Step 7.
	Indicator light continues to flash at 1 Hz rate.	Verify that the control is not in restricted mode. (See notes at end of this table.). If not in restricted mode, replace oil primary control
7. Listen for spark after burner turns on (after 2 second delay).	Ignition is off	Spark igniter could be defective. Check for line voltage at igniter terminals. If line voltage is present, replace oil primary control.
	Ignition is on.	Go to Step 8.
	Ignition is on but no oil is being sprayed into the combustion chamber.	Wait for "Valve ON" delay to complete. Check oil supply, and oil line valve. Check for filter blockage or seized oil pump.
8. Check indicator light after flame is established, but before oil primary control locks out.	Indicator light is on until the control locks out and starts flashing during lockout.	Replace oil primary control
	Indicator light stays off.	Go to step 9.
9. Check cad cell sighting for view of flame. Disconnect line voltage power and open line switch. Unplug cad cell and clean cad cell face with soft clothe. Check sighting for clear view of flame. Replace cad cell in socket. Reconnect line voltage power and close line switch. Start burner.	Burner locks out.	Go to step 10.
	Burner keeps running.	System is OK.

**Table C-3: Oil Primary Control Troubleshooting** *continued.*

Procedure	Status	Corrective Action
<b>10.</b> Check cad cell. Disconnect line voltage power and open line switch. Remove existing cad cell and replace with new cad cell. Disconnect all wires from thermostat terminals to ensure that there is no call for heat. Reconnect line voltage power and close line switch. Expose new cad cell to bright light such as a flashlight.	Indicator light is on.	Remount control onto burner housing. Go to step 6.
	Indicator light is off.	Go to step 11.
<b>11.</b> Check cad cell bracket assembly. Disconnect line voltage power and open line switch. Remove cad cell wires from quick connect connectors on and leave control lead wires open. Apply power to device. Place jumper across cad cell terminals after burner motor turns on.	Indicator light is on.	Replace cad cell bracket assembly.
	Indicator light is off.	Replace oil primary control.
<p><b>NOTE:</b> Restricted Mode - (Limited Reset): In order to limit the accumulation of unburned oil in the combustion chamber, the control can be reset only 3 times, after which, the control locks out. The reset count returns to zero each time a call for heat is successfully completed.                      To reset from RESTRICTED MODE: press and hold the reset button for 30 seconds. When the LED flashes twice, the device has reset.</p>		
<p><b>NOTE:</b> Disable function: Pressing and holding the reset button will disable all functions until the button is released. The burner will restart at the beginning of the normal heat cycle on SAFETY CHECK.</p>		

**Table C4: System and General Troubleshooting**

Problem	Possible Cause	Remedy
Furnace will not start.	Thermostat not calling for heat.	Check thermostat and adjust. Also, check thermostat for accuracy; if it is a mercury switch type, it might be off level.
	No power to furnace.	Check furnace switch, main electrical panel furnace fuse or circuit breaker. Also look for any other hand operated switch, such as an old poorly located furnace switch, which was not removed during furnace replacement.
	Thermostat faulty.	Remove thermostat wires from oil primary control terminals T-T. Place a jumper across T-T. If furnace starts, replace thermostat, thermostat sub-base (if equipped), or both.
	Oil primary control faulty.	Check reset button on oil primary control. Remove thermostat wires from oil primary control terminals T1 - T2. Check for 24V across T -T. If no voltage is present, check for 115V to oil primary control. If 115V is present, go to Table C-3.

**Table C-4: System and General Troubleshooting** *continued*

<b>Problem</b>	<b>Possible Cause</b>	<b>Remedy</b>
Furnace will not start.	Photo Cell wiring shorted or room light leaking into photo cell compartment	Check photo cell (cad cell) wiring for short circuits. Also, check for room light leaking into cad cell compartment. Repair light leak if necessary. See Table C-3.
	Open safety switch.	Check for open limit or auxiliary limit. Also, check internal wiring connections; loose connectors, etc.
Furnace will not start without first pushing oil primary control reset button. (Happens on frequent basis)	No fuel oil.	Check fuel oil supply. Check that all hand operated fuel oil valves are in the open position. Fill oil storage tank if necessary.
	Clogged nozzle.	Replace nozzle with high quality replacement. Use rating plate or Tables in Appendix A as a guide.
	Clogged oil filter.	Replace oil tank filter or in-line filter if used.
	Low oil pump pressure.	Connect pressure gauge to oil pump. Adjust pump pressure, or replace oil pump if necessary. Ensure that erratic pressure readings are not caused by defective fuel oil line.
	Air getting into fuel oil lines, or fuel oil line dirty, clogged, or in some manner defective.	Check fuel oil lines. Replace any compression fittings found with high quality flared fittings. Check for any signs of oil leaks. Any oil leak is a potential source of air or contaminants.
	Defective burner motor.	Check burner motor. If burner motor is cutting out on over-load, determine why. Replace if necessary.
Furnace starts, but cuts out requiring manually resetting the oil protector reset button.	Photo Cell (Cad Cell) defective.	If cad cell is dirty, clean it. (Determine why cad cell is getting dirty). If cad cell is poorly aimed, realign it. NOTE: The photocell should have a resistance of 100 K $\Omega$ in absence of light; a maximum of 1500 $\Omega$ in the presence of light. Ensure that room light is not leaking into the cad cell compartment. (See diagnostic light section).
Furnace starts, but cuts out requiring manually resetting the oil protector reset button.	No fuel oil.	Check fuel oil supply. Check that all hand operated fuel oil valves are in the open position. Fill oil storage tank if necessary.
	Clogged nozzle.	Replace nozzle with high quality replacement. Use rating plate or Tables in Appendix A as a guide.
	Clogged oil filter.	Replace oil tank filter or in-line filter if used.
	Low oil pump pressure.	Connect pressure gauge to oil pump. Adjust pump pressure, or replace oil pump if necessary. Ensure that erratic pressure readings are not caused by defective fuel oil line.
	Air getting into fuel oil lines, or fuel oil line dirty, clogged, or in some manner defective.	Check fuel oil lines. Replace any compression fittings found with high quality flared fittings. Check for any signs of oil leaks. Any oil leak is a potential source of air or contaminants.
	Defective burner motor.	Check burner motor. If burner motor is cutting out on over-load, determine why. Replace if necessary.
	Water or contaminants in oil.	Drain fuel oil storage tank; replace fuel oil. (Consult with fuel oil supplier).
	Frozen oil line.	Gently warm oil line. Insulate oil line. (Outdoor piping size may require increased diameter).
Oil burner sputtering at nozzle	Electrodes out of adjustment or defective.	Check electrode settings. Check electrodes for dirt build-up or cracks in porcelain.
	Poor transformer high voltage connections or defective transformer.	Check contacts between the igniter and electrodes. If OK, replace the igniter
	Fuel oil filter clogged.	Replace fuel oil storage tank filter and / or fuel oil in-line filter.
	Defective oil pump.	Check burner motor and / or fuel oil pump coupling. Check oil pump pressure. Replace fuel oil pump if necessary.
	Fuel oil line partially clogged or contains air.	Bleed air from oil line. If problem persists, replace oil line.

**Table C-4: System and General Troubleshooting** *continued*

<b>Problem</b>	<b>Possible Cause</b>	<b>Remedy</b>
Excessive fuel oil consumption.	System temperature rise too high.	System temperature rise ideally should not exceed 85°F. Check for clogged air filters. Check blower fan for excess dirt build-up or debris. Speed up blower fan if necessary.
	Poor "fan off" delay timing selection, (fan stops too soon).	Check "fan off" delay timing setting. Use a duct thermometer in the supply air plenum take-off or first few inches of the supply air trunk duct. Ideally, the fan will shut off at a temperature of 90° - 100°F. Manipulate the dip switch settings to come as close as possible to this "fan off" temperature.
	Fuel oil leak.	Check fuel oil line for leaks. Repair or replace if necessary.
	Stack temperature too high.	Check stack temperature. Stack temperatures will normally range from 350° to 450°F. Check draft regulator. Draft should be set to -0.02 in. w.c.
	Thermostat improperly adjusted or in poor location.	Check thermostat heat anticipator setting against measured amperage draw. Increase heat anticipator setting if necessary. If the thermostat is being influenced by drafts, sunlight, duct work, etc., relocate to more suitable location.
Too much smoke.	Insufficient combustion air adjustment at oil burner, or improper draft pressure.	Adjust the oil burner combustion air band and draft regulator to gain the highest practical CO <sub>2</sub> or lowest practical O <sub>2</sub> content in the flue gases. See Burner Set Up.
	Heat exchanger partially clogged.	Check for soot build-up in heat exchanger flue passages, especially in the outer radiator.
Soot building up on blast tube (end coning).	Poor alignment between oil burner blast tube and fire pot.	Check alignment. Blast tube should be centered with fire pot burner opening. Oil burner head should be ¼ inch back from the inside surface of the fire pot.
	Flame impingement caused by incorrect nozzle angle.	Check nozzle size and angle. (See Appendix A). Check distance from head to inside surface of the fire pot.
	Defective fire-pot	Check fire-pot. Repair or replace.
Furnace will not warm home to desired temperature.	Airflow blocked or dirty air filter.	Clean or replace air filter.
	Thermostat adjustments or location.	Check thermostat heat anticipator setting against measured amperage draw. Increase heat anticipator setting if necessary. If the thermostat is being influenced by drafts, sunlight, duct work, etc., relocate to more suitable location.
	Insufficient airflow.	Check all dampers. Open closed dampers including registers in unused rooms. Check system temperature rise. If temperature rise is too high, speed up blower fan.
	Defective high limit control.	Test high limit function of all limit switches. Use a duct thermometer to assess accuracy of limit control. Check for obstructions to airflow around limit switch bi-metal elements. Replace control if necessary.
	Under-sized nozzle.	Check nozzle. If problem is not caused by air flow problems, use larger nozzle, if permitted by rating plate.
	Blower fan motor stopping intermittently on overload.	Check blower fan motor amperage draw. Check motor ventilation ports, clean if necessary. Replace motor if necessary.
	Burner motor stopping intermittently on overload.	Check burner motor. Replace if necessary.
Home does not heat evenly	Improper distribution of heat.	This is not likely to be a furnace problem. Balance duct system.

**Table C-4: System and General Troubleshooting** *continued*

<b>Problem</b>	<b>Possible Cause</b>	<b>Remedy</b>
Supply air temperature too hot.	Airflow blocked or dirty air filter.	Clean or replace air filter.
	Insufficient airflow.	Check all dampers. Open closed dampers including registers in unused rooms. Check system temperature rise. If temperature rise is too high, speed up blower fan.
Supply air temperature too cool.	Excess airflow.	Check system temperature rise. Slow down blower fan if necessary.
	Excessive duct losses.	Check supply air ductwork. Seal leaky joints and seams. Insulate ductwork if necessary.
Supply air temperature too cool during first moments of furnace cycle.	Fan control "fan on" setting too low.	Increase "fan on" dipswitch settings on EFT if control has this option.). Register air deflectors may help.
	Excessive duct losses.	Check supply air ductwork. Seal leaky joints and seams. Insulate ductwork if necessary.

**FINAL CHECK OUT**

**ENSURE THAT ALL SAFETY DEVICES AND ELECTRICAL COMPONENTS HAVE BEEN SET FOR NORMAL OPERATION. ENSURE THAT ALL ELECTRICAL CONNECTIONS ARE TIGHT AND THAT THE WIRING IS SECURE.**



**IMPORTANT:**

Please ensure that the homeowner is informed and understands:

1. Where the circuit breaker or fuse is located in the main electrical panel.
2. Where the furnace switch is located, and the switch "on" and "off" positions if not obvious.

3. Where the oil shut-off valve from the oil storage tank is located.
4. How to operate the thermostat, and other related accessories.
5. How to operate the manual reset button on the primary control, and especially when not to push the reset button.
6. How and where to visually inspect the venting system for leaks or other problems.
7. How to inspect, clean and replace the air filter, and other homeowner maintenance procedures.
8. Who to call for emergency service and routine annual service.
9. The terms and conditions of the manufacturer's warranty and the contractor's warranty.

**HOMEOWNER'S REFERENCE TABLE**

Model No.	
Serial No.	
Date Installed	
Contractor	
Contact	
Address	
Postal Code	
Telephone No.	
After Hours No.	

**FUEL SUPPLIER**

Fuel Oil Supplier	
Contact	
Telephone No.	
After Hours No.	

**IF DIFFERENT FROM INSTALLATION CONTRACTOR:**

Service Tech.	
Telephone No.	
After Hours No.	

## PARTS LISTING: HIGHBOY MODEL: HML-80C AND HMLV-80C

Ref. No.	Description	Part No.
1	Left Side Panel Assembly	29187L
2	Right Side Panel Assembly	29186L
3	Rear Panel	29205L
4	Blower Division Assembly	29189
5	Base Panel	26216
6	Inner Front Panel	30066
7	Blower Access Panel	27721L
8	Top Panel	21437L
9	Heat Exchanger Assembly	28675
10	Combustion Chamber Retainer Bracket	27068
11	Replacement Combustion Chamber	27000WP
12	Oil Burner Mounting Plate	29869
13	Flue Connector	29005
14	Pouch Gasket	2080175
15	Flue Collar Gasket	21994
16	Insulation Retainer	20602
17	Radiator Clean-out Cover (2 per unit)	29162
17	Radiator Clean-out Cover Gasket (2 per unit)	240006333
18	Clean-out Gasket Retainer	29161
18	Clean-out Tube Gasket	29163
19	Filter Frame 16" X 25"	18020
20	Filter Frame End Support	5592B2
21	Filter 16" X 25" X 1" Permanent	2180023
24	Control Box	29362
25	Upper Door Panel	30164L
	Logo Bezel	28479
	Logo Label	28563
26	Limit Disc 60T11 BOF 155°F	30071
27	Fan Timer Control 1158-120 UTEC	29388
	Fan Timer Control 1168-1 ECM UTEC	240007048
28	Wire Harness, Controls Fan Timer	29364
29	Wire Harness, Blower	29365
30	Wire Harness, Fan Timer Board, Transformer	29751
31	Wire Harness, ECM Control	240006438
31	Wire Harness, ECM Supply	240005742
32	Transformer	27738
33	Draft Regulator	27494 (5")
34	Oil Burner Assembly, Beckett AF76BNHS	30067
	Burner Motor 1/7 HP 3450 RPM PSC	29689
	Beckett Clean-cut Oil Pump A2EA6520	29688
	Solid State Ignitor 10SAY-01	29522
	Oil Primary Combustion Control	29664
	Flame Retention Head	11961 (F3)
	Nozzle, 0.65/80°A	210086
	Low Fire Kit	29880
	Low Firing Rate Baffle	25521101
	Nozzle, 0.50/80° A	29389

**PARTS LISTING: HIGHBOY MODEL: HML-80C  
HMLV-80C**

<b>Ref. No.</b>	<b>Description</b>	<b>Part No.</b>
35	Blower Assembly Direct Drive	30146
	Blower Assembly Direct Drive ECM	109007271
	Blower Housing and Wheel, 100-10T DD (HML-C and HMLV-C)	30626
	Blower Motor, 1/2 hp, 4-Speed	102000131
	Blower Motor, 1/2 hp, ECM Programmed	109007272
	Motor Mounting Band – TR6884B	17811
	Motor Mount Arms – 10-10 DD Blower (3 per unit)	26251
	Motor Run Capacitor, 10 mfd @ 370 Vac	27743
	Capacitor Strap	27760
	Blower Slide Rail 2 Per	27733
36	Right Side Panel, Air Baffle HML- 80C and HMLV-80C	27731

**PARTS LISTING: HIGHBOY DIRECT VENT MODEL: HML-80CB2U  
HMLV-80CB2U**

<b>Ref. No.</b>	<b>Description</b>	<b>Part No.</b>
	All parts are the same as listed on the previous pages for Models HML-80C and HMLV-80C except where noted below.	
12	Oil Burner Mounting Plate Assembly	29872
	Oil Burner Mounting Plate	29867
	Sight Glass Cover Plate	29850
	Sight Glass Gasket (2 per unit)	29870
	Sight Glass	29876
13	Flue Connector Assembly 6" to 4" 90° Elbow	28952
14	Pouch Gasket (Second gasket required for Direct Vent)	2080175
15	Flue Collar Gasket (Second gasket required for Direct Vent)	21994
25	Upper Door Panel	27722L
34	Beckett Oil Burner AFII 85	30069
	Burner Motor 1/7 HP 3450 RPM PSC	28907
	Beckett Clean-cut Oil Pump A2EA6520	29688
	Solid State Ignitor 10SAY-01	28558
	Oil Primary Combustion Control	29649
	Air Tube Combination FBX80HGXS	28561
	Flame Retention Head (FB3)	28533
	Nozzle, 0.60/60°A (HML-80CB2U and HMLV-80CB2U only)	28017



# MODEL HML-C AND HMLV-C DIAGRAM

