

# Installation, Operating and Service Instructions for



- Steam Boiler
- Natural Draft
- Oil-Fired

**Models:**

- CL3-105SE    • CL3-105SET
- CL3-140SE    • CL3-140SET
- CL4-168SE    • CL4-168SET
- CL4-210SE    • CL4-210SET
- CL5-245SE    • CL5-245SET
- CL5-266SE    • CL5-266SET

<u>Manual Contents</u>	<u>Page</u>
1. Product Description, Specification & Dimensional Data	5
2. Pre-Installation	9
3. Steam Boiler Piping & Trim	11
4. Tankless & Indirect Water Heater Piping	13
5. Venting	16
6. Electrical	17
7. Oil Piping	20
8. System Start-up	22
9. Operating	25
10. Maintenance & Service Instructions	27
11. Boiler Cleaning	30
12. Troubleshooting	32
13. Service Parts	34
14. Burner Specifications	40
Appendix	41

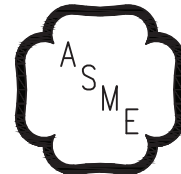
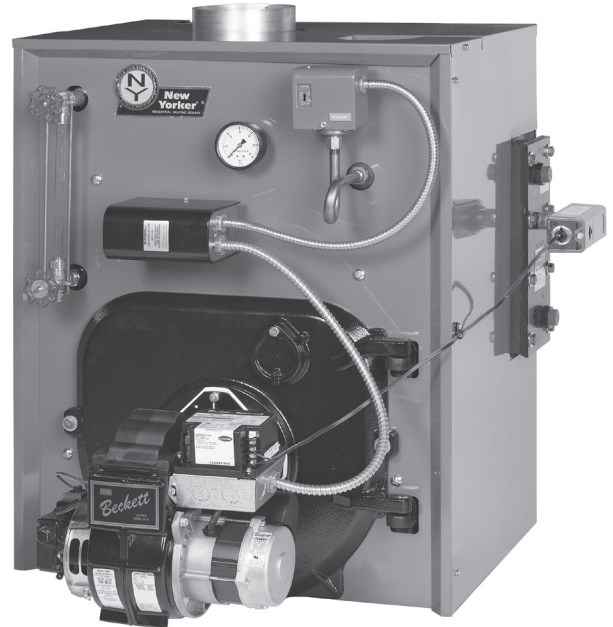

**Intertek**  
9700609

H

**TO THE INSTALLER:**

Affix these instructions adjacent to boiler.

**TO THE CONSUMER:**

Retain these instructions for future reference.



For service or repairs to boiler, call your heating contractor. When seeking information on boiler, provide Boiler Model Number and Serial Number as shown on Rating Label.

---

**IMPORTANT INFORMATION - READ CAREFULLY**

---

All boilers must be installed in accordance with National, State and Local Plumbing, Heating and Electrical Codes and the regulations of the serving utilities. These Codes and Regulations may differ from this instruction manual. Authorities having jurisdiction should be consulted before installations are made.

In all cases, reference should be made to the following Standards:

**USA BOILERS**

- A. Current Edition of American National Standard ANSI/NFPA 31, "Installation of Oil Burning Equipment"; for recommended installation practices.
- B. Current Edition of American National Standard ANSI/NFPA 211, "Chimneys, Fire places, Vents, and Solid Fuel Burning Appliances"; For Venting requirements.
- C. Current Edition of American Society of Mechanical Engineers ASME CSD-1, "Controls and Safety Devices for Automatically Fired Boilers"; for assembly and operations of controls and safety devices.
- D. All wiring on boilers installed in the USA shall be made in accordance with the National Electrical Code and/or Local Regulations.

The following terms are used throughout this manual to bring attention to the presence of hazards of various risk levels, or to important information concerning product life.

**⚠ DANGER**

Indicates a hazardous situation that, if not avoided, will result in death or serious injury.

**⚠ CAUTION**

Indicates a hazardous situation that, if not avoided, could result in minor or moderate injury.

**⚠ WARNING**

Indicates a hazardous situation that, if not avoided, could result in death or serious injury.

**NOTICE:** Indicates special instructions on installation, operation, or service which are important but not related to personal injury hazards.

**NOTICE:** This boiler has a limited warranty, a copy of which is included with this boiler. The warranty for this boiler is valid only if the boiler has been installed, maintained and operated in accordance with these instructions.

Surface rust on cast iron sections may be attributed to the manufacturing process as well as condensation during storage. Surface rust is normal and does not affect the performance or longevity of a boiler.

** DANGER**

DO NOT store or use gasoline or other flammable vapors or liquids in the vicinity of this or any other appliance.

** WARNING**

- Improper installation, adjustment, alteration, service or maintenance can cause property damage, personal injury or loss of life. Failure to follow all instructions in the proper order can cause personal injury or death. Read and understand all instructions, including all those contained in component manufacturers manuals which are provided with the boiler before installing, starting-up, operating, maintaining or servicing this boiler. Keep this manual and literature in legible condition and posted near boiler for reference by owner and service technician.

- This boiler requires regular maintenance and service to operate safely. Follow the instructions contained in this manual.

- Installation, maintenance, and service must be performed only by an experienced, skilled and knowledgeable installer or service agency.

- All heating systems should be designed by competent contractors and only persons knowledgeable in the layout and installation of hydronic heating systems should attempt installation of any boiler.

- Installation is not complete unless a pressure relief valve is installed into the tapping located on top left corner of front section- See Piping and Trim Sections of this manual for details.

- It is the responsibility of the installing contractor to see that all controls are correctly installed and are operating properly when installation is complete including verifying that the limit sensor is fully installed (seated in bottom of Well).

Failure to properly install Limit Sensor may result in property damage, personal injury or loss of life due to elevated operating temperatures and/or pressures.

- This boiler is suitable for installation on combustible flooring. Do not install boiler on carpeting.

- Do not tamper with or alter the boiler or controls.

- Inspect flueways at least once a year - preferably at the start of the heating season. The inside of the combustion chamber, the vent system and boiler flueways should be cleaned if soot or scale has accumulated.

- When cleaning this boiler, DO NOT damage combustion chamber liner and/or rear target wall. If damaged, combustion chamber insulation must be replaced immediately.

- Oil Burner and Controls must be checked at least once a year or as may be necessitated.

- Do not operate boiler with jumpered or absent controls or safety devices.

- Do not operate boiler if any control, switch, component, or device has been subject to water.

- Boiler materials of construction, products of combustion and the fuel contain alumina, silica, heavy metals, carbon monoxide, nitrogen oxides, aldehydes and/or other toxic or harmful substances which can cause death or serious injury and which are known to the state of California to cause cancer, birth defects and other reproductive harm. Always use proper safety clothing, respirators and equipment when servicing or working nearby the boiler.

 **WARNING**

- This boiler contains very hot water under high pressure. Do not unscrew any pipe fittings nor attempt to disconnect any components of this boiler without positively assuring the water is cool and has no pressure. Always wear protective clothing and equipment when installing, starting up or servicing this boiler to prevent scald injuries. Do not rely on the pressure and temperature gauges to determine the temperature and pressure of the boiler. This boiler contains components which become very hot when the boiler is operating. Do not touch any components unless they are cool.
- High water temperatures increase the risk of scalding injury. If this boiler is equipped with a tankless heater for domestic water supply, a flow regulator and automatic mixing valve must be installed properly in tankless heater piping. See Piping and Trim Sections of this manual for details.
- This boiler must be properly vented and connected to an approved vent system in good condition. DO NOT operate boiler with the absence of an approved vent system.
- This boiler needs fresh air for safe operation and must be installed so there are provisions for adequate combustion and ventilation air.
- A clean and unobstructed chimney flue is necessary to allow noxious fumes that could cause injury or loss of life to vent safely and will contribute toward maintaining the boiler's efficiency.
- This boiler is supplied with controls which may cause the boiler to shut down and not re-start without service. If damage due to frozen pipes is a possibility, the heating system should not be left unattended in cold weather; or appropriate safeguards and alarms should be installed on the heating system to prevent damage if the boiler is inoperative..
- This boiler is designed to burn No. 2 fuel oil only. DO NOT use gasoline, crankcase drainings, or any oil containing gasoline. Never burn garbage or paper in this boiler. DO NOT convert to any solid fuel (i.e. wood, coal). DO NOT convert to any gaseous fuel (i.e. natural gas, LP). All flammable debris, rags, paper, wood scraps, etc., should be kept clear of the boiler at all times. Keep the boiler area clean and free of fire hazards.
- All boilers equipped with burner swing door have a potential hazard which if ignored can cause severe property damage, personal injury or loss of life. Before opening swing door, turn off service switch to boiler to prevent accidental firing of burner outside the combustion chamber. Be sure to tighten swing door fastener completely when service is completed.

# 1 Product Description, Specification and Dimensional Data

The CL Series boiler is a cast iron oil-fired low pressure steam boiler designed for use in closed heating steam systems. This boiler must be vented by natural draft into a fireclay tile-lined masonry chimney or chimney constructed from type L vent or a factory built chimney that complies with the type HT requirements of UL103. An adequate supply of air for combustion, ventilation and dilution of flue gases must be available in the boiler room.

The CL Series steam boiler uses a L404F Pressure Limit and Low Water Cut-off. This boiler has indirect domestic water heater connections to generate domestic hot water. Optionally, this boiler may include a L4006 Temperature Limit and a tankless heater to generate domestic hot water.

**Table 1-2: Dimensional Data**

Boiler Model	Dimensions			Approv. Water Content Gallons	Heat Transfer Surface Area Sq. Ft.	Recommended Minimum Chimney	
	"A"	"B"	"C"			Round in Dia.	Rectangle in. x in.
CL3	17-3/8"	8-1/4"	5-7/8"	16	14.33	6	8 X 8
CL4	22-3/8"	10-7/8"	6-7/8"	20	20.90	7	
CL5	27-3/8"	13-3/8"	7-7/8"	24	27.46	8	

Maximum working water pressure: 15 PSI shipped standard from factory.

**Table 1-2: Rating Data**

Boiler Model	Burner Capacity		Heating Capacity <sup>(2)</sup> MBH	NET AHRI Ratings <sup>(3)</sup>		AFUE %
	GPH	MBH <sup>(1)</sup>		MBH	Sq. Ft.	
CL-3-105SE	0.75	105	91	68	284	85.7
CL3-410SE	1.00	140	121	91	378	85.0
CL4-168SE	1.20	168	147	110	459	86.4
CL4-210SE	1.50	210	181	136	566	85.1
CL5-245SE	1.75	245	212	159	663	85.6
CL5-266SE	1.90	266	230	173	719	85.3

<sup>(1)</sup> MBH refers to thousands of BTU per hour.

<sup>(2)</sup> Based on standard test procedure prescribed by the United States Department of Energy at combustion conditions of 13.0% CO<sub>2</sub>.

<sup>(3)</sup> Net AHRI Ratings are based on piping and pickup allowance of 1.333 for steam.

# 1 Product Description, Specification and Dimensional Data (continued)

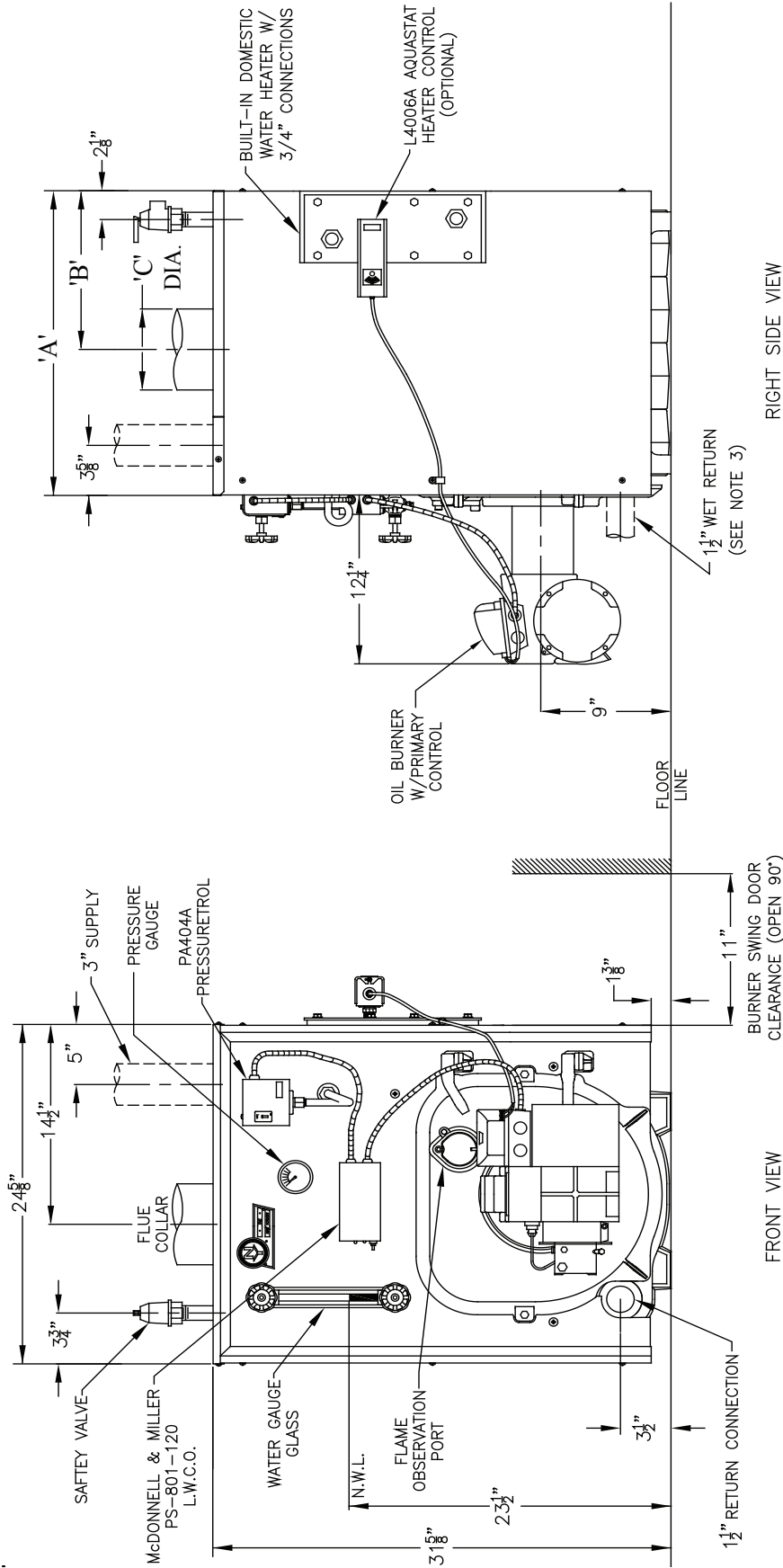

- NOTES:
1. TANKLESS COIL OPENING NOT PRESENT ON LESS-COIL BOILERS.
  2. PIPING SHOWN HIDDEN NOT FURNISHED WITH BOILER.
  3. DRAIN VALVE SHIPPED LOOSE. (NOT SHOWN)

Figure 1-3: Steam Boiler with or without Tankless Heater

## 2 Pre-Installation

- A. INSPECT SHIPMENT carefully for any signs of damage.
1. All equipment is carefully manufactured, inspected and packed. Our responsibility ceases upon delivery of crated boiler to the carrier in good condition.
  2. Any claims for damage or shortage in shipment must be filed immediately against the carrier by the consignee. No claims for variances from, or shortage in orders, will be allowed by the manufacturer unless presented within sixty (60) days after receipt of goods.
- B. LOCATE BOILER in front of final position before removing crate. See Figure 1-1.
1. LOCATE so that vent pipe connection to chimney will be short and direct.
  2. BOILER IS SUITABLE FOR INSTALLATION ON COMBUSTIBLE FLOOR. Boiler cannot be installed on carpeting.
3. FOR BASEMENT INSTALLATION, provide a solid elevated base, such as concrete, if floor is not level, or if water may be encountered on floor around boiler.
  4. PROVIDE SERVICE CLEARANCE of at least 24" clearance from front jacket panel for servicing. If boiler is equipped with a rear tankless heater, provide at least 24" service clearance on the right side of the boiler. Boiler flueways may be cleaned from the top. Provide at least 24" clearance from the top of the boiler for cleaning flueways.
  5. For minimum clearances to combustible materials. See Figure 2-1.
- C. PROVIDE COMBUSTION AND VENTILATION AIR. Local and National Codes may apply and should be referenced.

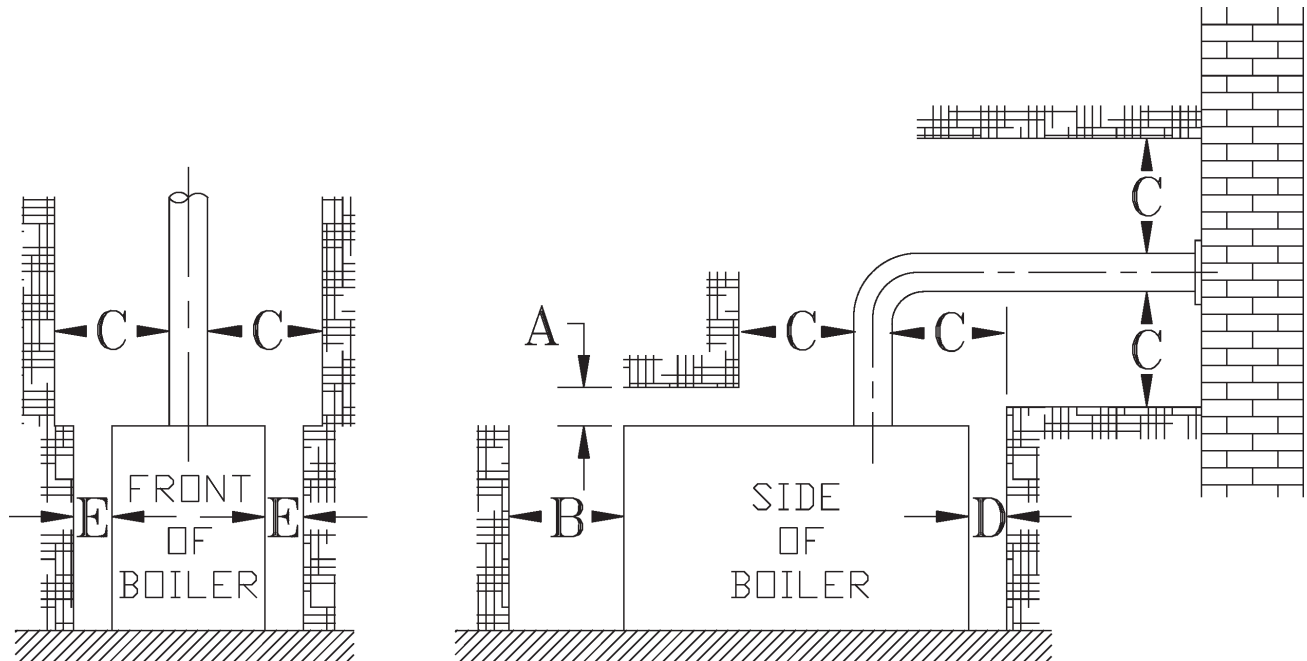

**Figure 2-1: Minimum Installation Clearances To Combustible Materials (Inches)**

### NOTES:

1. Listed clearances comply with American National Standard ANSI/NFPA 31, Installation of Oil Burning Equipment.
2. CL Series boilers can be installed in rooms with clearances from combustible material as listed above. Listed clearances cannot be reduced for alcove or closet installations.
3. For reduced clearances to combustible material, protection must be provided as described in the above ANSI/NFPA 31 standard.

## 2 Pre-Installation (continued)

**NOTICE:** Clearance to venting is for single wall vent pipe. If Type L vent is used, clearance may be reduced to the minimum required by the vent pipe manufacturer.

### WARNING

Adequate combustion and ventilation air must be provided to assure proper combustion and to maintain safe ambient air temperatures.

DO NOT install boiler where gasoline or other flammable vapors or liquids, or sources of hydrocarbons (i.e. bleaches, fabric softeners, etc.) are used or stored.

1. Determine volume of space (boiler room). Rooms communicating directly with the space in which the appliances are installed, through openings not furnished with doors, are considered a part of the space.  

$$\text{Volume}(\text{ft}^3) = \text{Length}(\text{ft}) \times \text{Width}(\text{ft}) \times \text{Height}(\text{ft})$$
2. Determine total input of all appliances in the space.  
 Add inputs of all appliances in the space and round the result to the nearest 1000 BTU per hour.
3. Determine type of space. Divide Volume by total input of all appliances in space. If the result is greater than or equal to 50 ft<sup>3</sup>/1000 BTU per hour, then it is considered an *unconfined space*. If the result is less than 50 ft<sup>3</sup>/1000 BTU per hour then the space is considered a *confined space*.
4. For boiler located in an *unconfined space of a conventionally constructed building*, the fresh air infiltration through cracks around windows and doors normally provides adequate air for combustion and ventilation.
5. For boiler located in a confined space or an unconfined space in a building of unusually tight construction, provide outdoor air.
  - a. Outdoor air may be provided with the use of two permanent openings which communicate directly or by duct with the outdoors or spaces (crawl or attic) freely communicating with the outdoors. Locate one opening within 12 inches of top of space. Locate remaining opening within 12 inches of bottom of space. Minimum dimension of air opening is 3 inches. Size each opening per following:
    - i. **Direct communication with outdoors.** Minimum free area of 1 square inch per 4,000 BTU per hour input of all equipment in space.
    - ii. **Vertical ducts.** Minimum free area of 1 square inch per 4,000 BTU per hour input of all equipment in space. Duct cross-sectional area shall be same as opening free area.
    - iii. **Horizontal ducts.** Minimum free area of 1 square inch per 2,000 BTU per hour input of all equipment in space. Duct cross-sectional area shall be same as opening free area.  
 Alternate method for boiler located within confined space. Use indoor air if two permanent openings communicate directly with additional space(s) of sufficient volume such that combined volume of all spaces meet criteria for unconfined space. Size each opening for minimum free area of 1 square inch per 1,000 BTU per hour input of all equipment in spaces, but not less than 100 square inches.
6. Louvers and Grilles of Ventilation Ducts
  - a. All outside openings should be screened and louvered. Screens used should not be smaller than 1/4 inch mesh. Louvers will prevent the entrance of rain and snow.
  - b. Free area requirements need to consider the blocking effect of louvers, grilles, or screens protecting the openings. If the free area of the louver or grille is not known, assume wood louvers have 20-25 percent free area and metal louvers and grilles have 60-75 percent free area.
  - c. Louvers and grilles must be fixed in the open position, or interlocked with the equipment to open automatically during equipment operation.



### 3 Steam Boiler Piping and Trim

#### WARNING

- Failure to properly pipe boiler may result in improper operation and damage to boiler or structure.
- **DO NOT** increase steam boiler input above the ratings.
- **DO NOT** use softened water in steam boilers. Accelerated boiler corrosion will result. Tie in fresh water supply to the boiler upstream of a water softener.
- Oxygen contamination of boiler water will cause corrosion of iron and steel boiler components, and can lead to boiler failure. U.S. Boiler Company's Standard Warranty does not cover problems caused by oxygen contamination of boiler water or scale (lime) build-up caused by frequent addition of water.

#### A. EVALUATE THE EXISTING STEAM SYSTEM.

The single most important factor in determining the expected life cycle of a steam boiler, is the amount of fresh water added to the boiler during operation. Fresh water brings minerals and oxygen into the boiler. These contaminants greatly accelerate corrosion of the cast iron boiler sections.

1. Assure that all system radiators, piping and vents are absolutely leak tight.
  - a. When a steam boiler is installed in an existing system, ALL air vents should be replaced at the same time. This assures that the new boiler will not be compromised by existing system leaks.

- b. If the system contains hidden supply or return piping (hidden behind walls, buried in concrete, etc.) pressure test this piping to assure there are no leaks.

2. Repair any leaks in the system.
3. Install accurate water meter on the fresh water supply to the boiler.

#### B. CONNECT SYSTEM SUPPLY AND RETURN PIPING TO BOILER. See Figure 3-1 for piping details. Also consult Residential Hydronic Heating Installation and Design I=B=R Guide.

#### CAUTION

Maintain minimum ½ inch clearance from hot water piping to combustible materials.

**NOTICE** Before using copper for steam piping, consider the following characteristics of copper piping:

1. high coefficient of thermal expansion can induce mechanical stresses and cause expansion/contraction noises if not accounted for in the piping system design and installation,
2. high heat transfer rate (heat loss) of uninsulated copper piping must be included in the normal piping and pickup factors used to size the boiler,
3. soldering or brazing pastes and fluxes that end up in the system can cause poor heat transfer, surging, an unsteady water line and wet steam if not thoroughly removed during the boil out procedure and,
4. galvanic corrosion of the adjoining metal may occur due to dissimilar metals in certain water chemistries if dielectric unions are not used.

### 3 Steam Boiler Piping and Trim (continued)

**NOTICE** Failure to pipe boiler as specified in this manual may result in excessive system noise, water line fluctuations and water carry over.

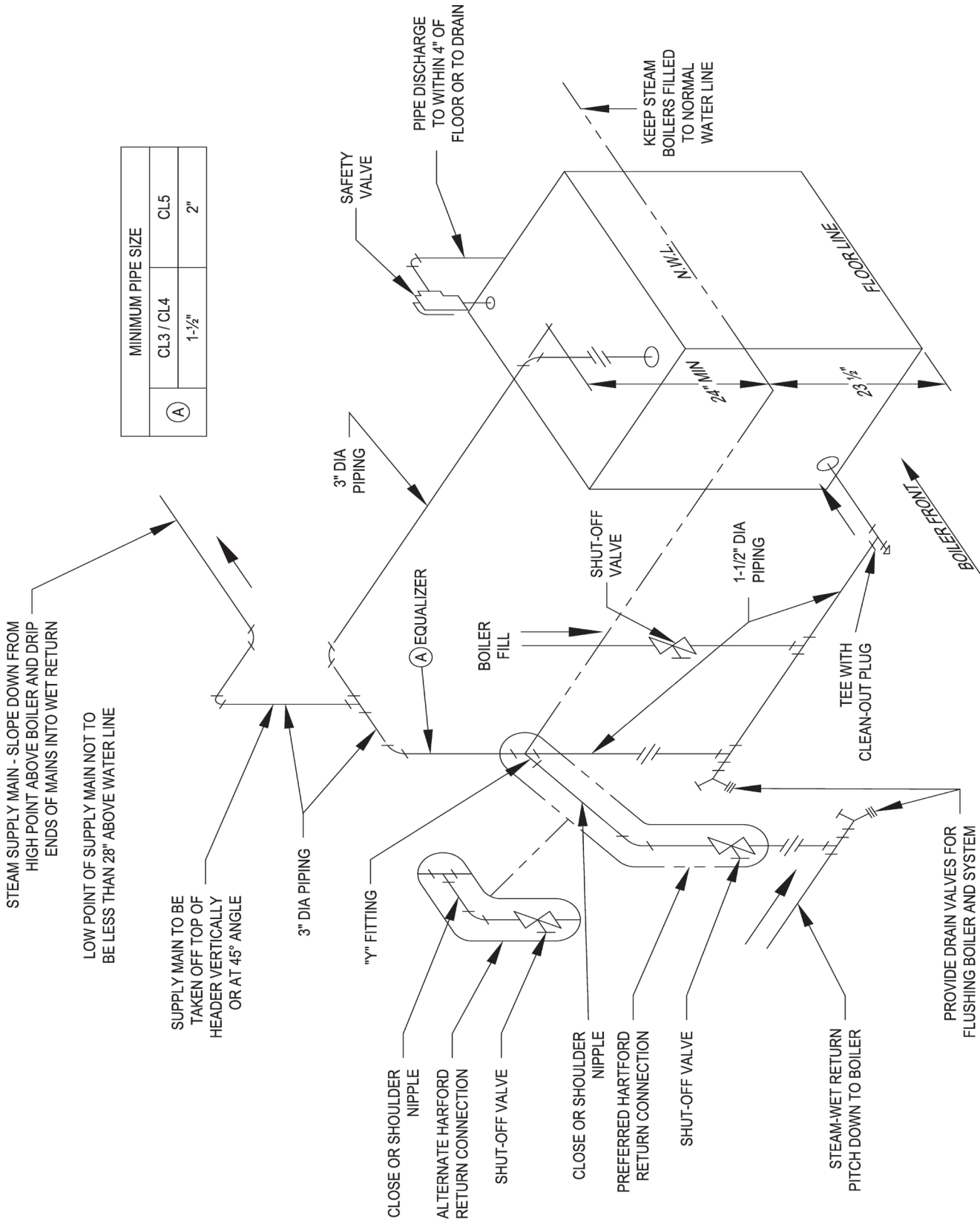

Figure 3-1: Recommended Boiler Piping for Gravity Return Steam Boiler

## 4 Tankless and Indirect Water Heater Piping

- A. CONNECT TANKLESS HEATER PIPING as shown in Figure 4-1. See Table 4-2 for Tankless Heater Rating.

### WARNING

Install automatic mixing valve at tankless heater outlet to avoid risk of burns or scalding due to excessively hot water at fixtures. Adjust and maintain the mixing valve in accordance with the manufacturer's instructions. DO NOT operate tankless heater without mixing valve.

THE FOLLOWING GUIDELINES SHOULD BE FOLLOWED WHEN PIPING THE TANKLESS HEATER:

1. **FLOW REGULATION** — If flow through the heater is greater than its rating, the supply of adequate hot water may not be able to keep up with the demand. For this reason a flow regulator matching the heater rating should be installed in the cold water line to the heater. The flow regulator should preferably be located below the inlet to the heater and a minimum of 3' away from the inlet so that the regulator is not subjected to excess temperatures that may occur during "off" periods when it is possible for heat to be conducted back through the supply line. The flow regulator also limits the flow of supply water regardless of inlet pressure variations in the range of 20 to 125 psi.
2. **TEMPERING OF HOT WATER** — Installation of an automatic mixing valve will lengthen the delivery of the available hot water by mixing some cold water with the hot. This prevents the possibility of scalding hot water at the fixtures. In addition, savings of hot water will be achieved since the user will not waste as much hot water while seeking a water temperature. Higher temperature hot water required by dishwashers and automatic washers is possible by piping the hot water from the heater prior to entering the mixing valve. The mixing valve should be "trapped" by installing it below the cold water inlet to heater to prevent lime formation in the valve. Refer to Figure 4-1.

### CAUTION

Use of hard water with a tankless coil will, over a short period of time, reduce the output of the coil, reduce flow due to increased pressure drop and reduce the useful life of the coil.

3. **FLUSHING OF HEATER** — All water contains some sediment which settles on the inside of the coil. Consequently, the heater should be periodically back washed. This is accomplished by installing hose bibs as illustrated and allowing water at city pressure to run into hose bib A, through the heater, and out hose bib B until the discharge is clear. The tees in which the hose bibs are located should be the same size as heater connections to minimize pressure drop.
4. **HARD WATER** — A water analysis is necessary to determine the hardness of your potable water. This is applicable to some city water and particularly to well water. An appropriate water softener should be installed based on the analysis and dealer's recommendation. This is not only beneficial to the tankless heater but to piping and fixtures plus the many other benefits derived from soft water.

**NOTICE** During summertime operation, the normal water line on a steam boiler can be raised 1", from 22-5/8" to 23-5/8" (see Figure 1-1) for improved tankless heater performance on steam boilers.

Use street elbow fittings in tankless in and out connections to assure adequate clearance of piping.

## 4 Tankless and Indirect Water Heater Piping (continued)

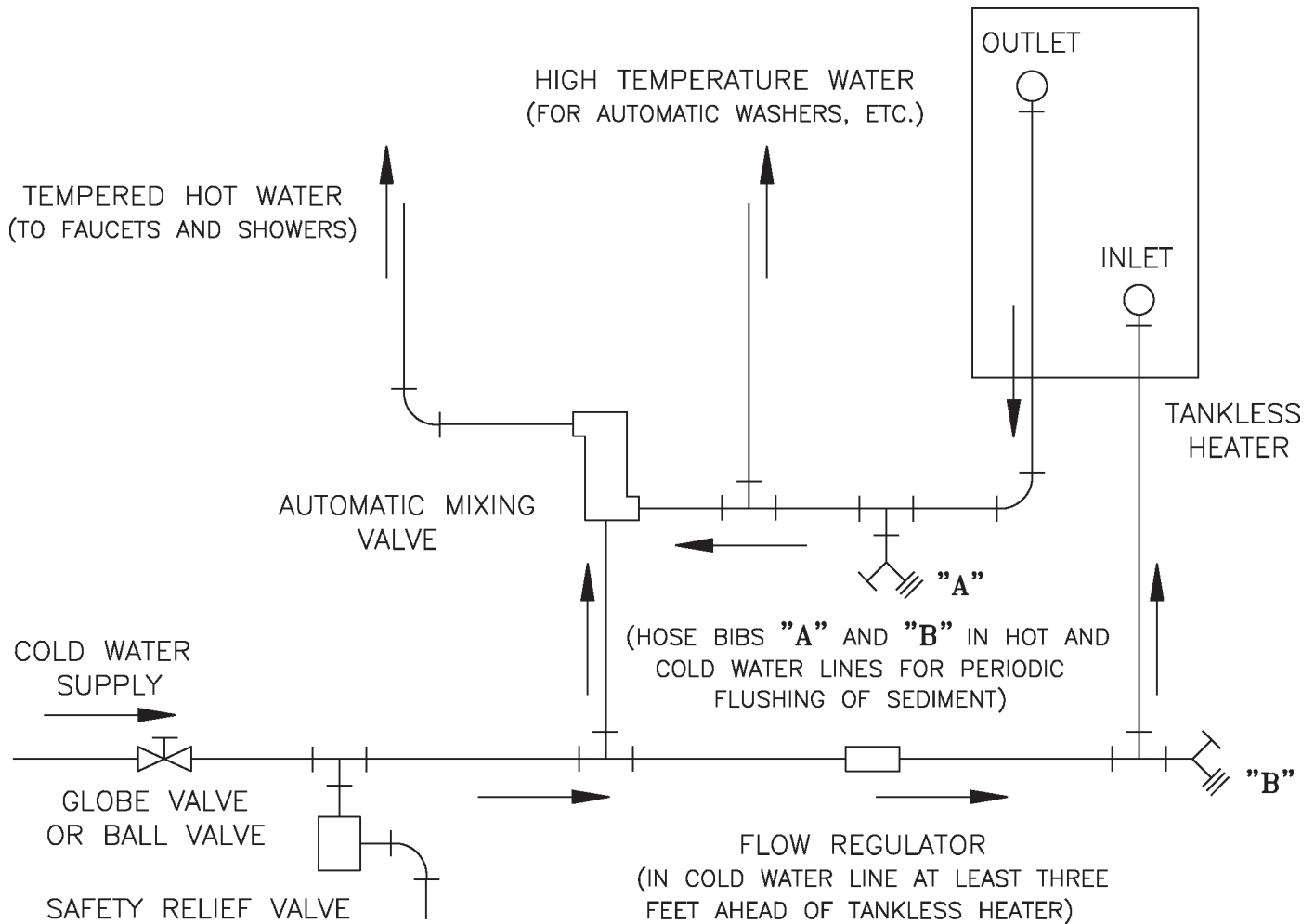
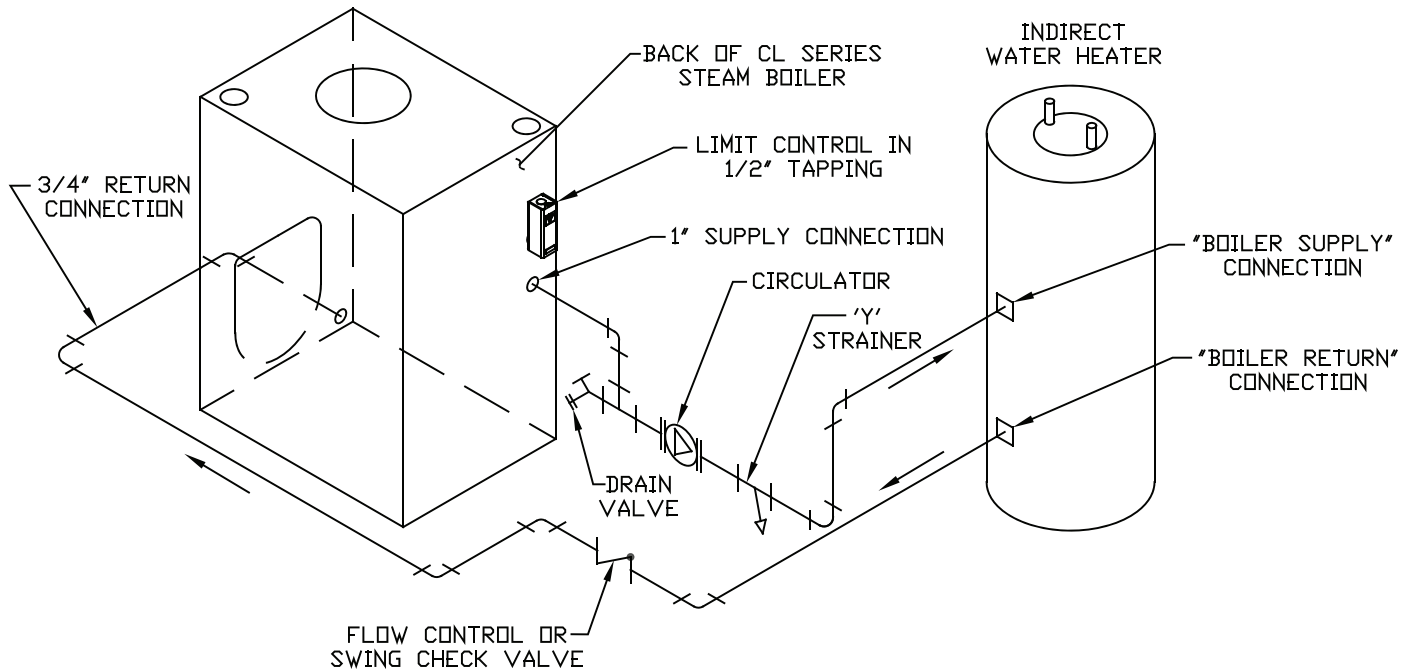

**Figure 4-1: Schematic Tankless Heater Piping**

**Table 4-2: Tankless Heater Data:**

Boiler Series	Rating (Gal/Min)	Pressure Drop (PSI)
CL3-105SE-T	3.00	4.7
CL3-140SE-T	3.25	5.6
CL4-168SE-T	3.75	7.2
CL4-210SE-T	4.00	8.0
CL5-245SE-T	4.25	8.8
CL5-266SE-T	4.75	9.6

## 4 Tankless and Indirect Water Heater Piping (continued)



**Figure 4-3: Indirect Domestic Water Heater Piping with V8H Steam Boiler**

- B. CONNECT INDIRECT DOMESTIC WATER HEATER PIPING as shown in Figure 4-3.
1. Refer to Indirect Water Heater Installation, Operating, and Service Instructions for additional information.

## 5 Venting

### WARNING

- Vent this boiler according to these instructions. Failure to do so may cause products of combustion to enter the home resulting in severe property damage, personal injury or death.
- Insufficient Combustion Air Supply may result in the production and release of deadly carbon monoxide (CO) into the home which can cause severe personal injury or death.
- Improper venting may result in property damage and the release of flue gases which contain deadly carbon monoxide (CO) into the home, which can cause severe personal injury, death, or substantial property damage.
- Inspect existing chimney and vent connector for obstructions and deterioration before installing boiler. Failure to clean or replace perforated pipe or chimney liner will cause severe injury or death.
- Do not de-rate the appliance. Failure to fire the boiler at it's designed input may cause excessive condensation upon the interior walls of the chimney. In addition, the lower input may not create enough draft to adequately evacuate the by-products of combustion.

#### A. GENERAL VENTING GUIDELINES

1. Chimney venting is an important part of a safe and efficient oil fired appliance system. Contact your local fire and building officials on specific requirements for restrictions and the installation of fuel oil burning equipment. In addition, consult with a professional knowledgeable on the requirements of NFPA 31 – Standard for the Installation of Oil-Burning Equipment and NFPA 211 - Standard for Chimneys, Fireplaces, Vents, and Solid Fuel-Burning Appliances for installations in the United States.
2. The safe venting of oil fired boilers is dependant on many factors. Some of these factors include:
  - a. sufficient draft during the entire heating season to allow for the safe discharge of combustion by-products and;
  - b. suitable corrosion protection in the event of condensing flue gases. Only a trained and qualified contractor may install this product.
3. The CL shall be vented into any of the following:
  - a. Masonry or metal chimney. Build and install in accordance with local buildings codes; or local authority having jurisdiction; or “Standards for Chimney, Fireplace, Vents, and Solid Fuel Burning Appliances”, ANSI/ NFPA 211 and/or National Building Code of Canada. Masonry chimney must be lined with listed chimney system. Listed clay flue lined masonry chimneys meet venting requirements.
    - External chimneys are more susceptible to flue gas condensation due to colder outside air temperatures. To prevent corrosion due to flue gas condensation, use a listed corrosion-resistant metal liner in chimney.
  - b. Oversized chimneys are more susceptible to flue gas condensation. To reduce the likelihood of flue gas condensation and ensure proper draft, use a properly sized listed metal liner in oversized chimney.
4. Chimney Inspection – Prior to the installation of any new or replacement fuel burning equipment the chimney shall be inspected by a qualified installer. The chimney shall be inspected for integrity as well as for proper draft and condensate control. Some jurisdictions require the use of a liner when changing fuel types. Some jurisdictions require the use of a liner even when the same fuel is used. At a minimum, the chimney shall be examined by a qualified person in accordance with the requirements of Chapter 11 of NFPA 211, Standard for Chimneys, Fireplaces, Vents, and Solid Fuel-Burning Appliances.
  - a. Loose Mortar – Loose mortar could be an indication of a prior history of condensing flue gases upon the inside walls of the chimney. Colder climates are more susceptible to this condition. Under no circumstances shall a chimney of this condition be used until it meets the requirements of NFPA 211 or CSA B139.
  - b. Unlined Chimney – Under no circumstances shall a chimney constructed of brick only be used. Only approved clay liners or listed chimney lining systems shall be used as specified in NFPA 31.
  - c. Abandoned Openings – Openings through the chimney wall that are no longer used shall be sealed in accordance to NFPA 211. Often abandoned openings are improperly sealed and usually covered by a gypsum wall covering.

# 5 Venting (continued)

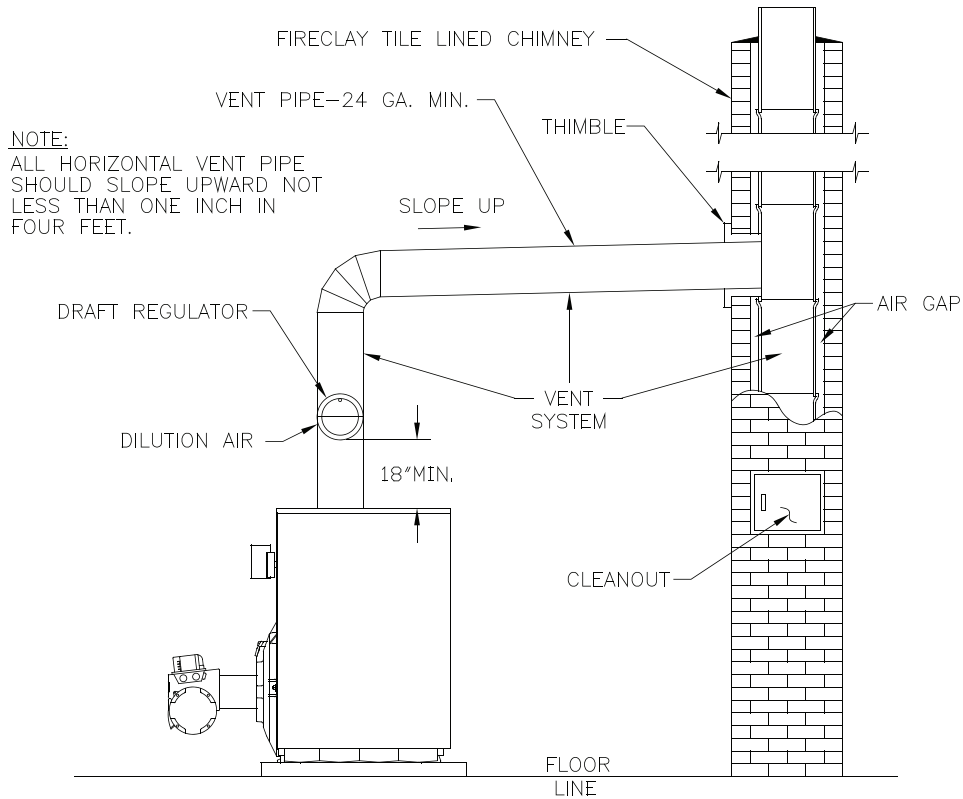

**Figure 5-1: Recommended Vent Pipe Arrangement and Chimney Requirements**

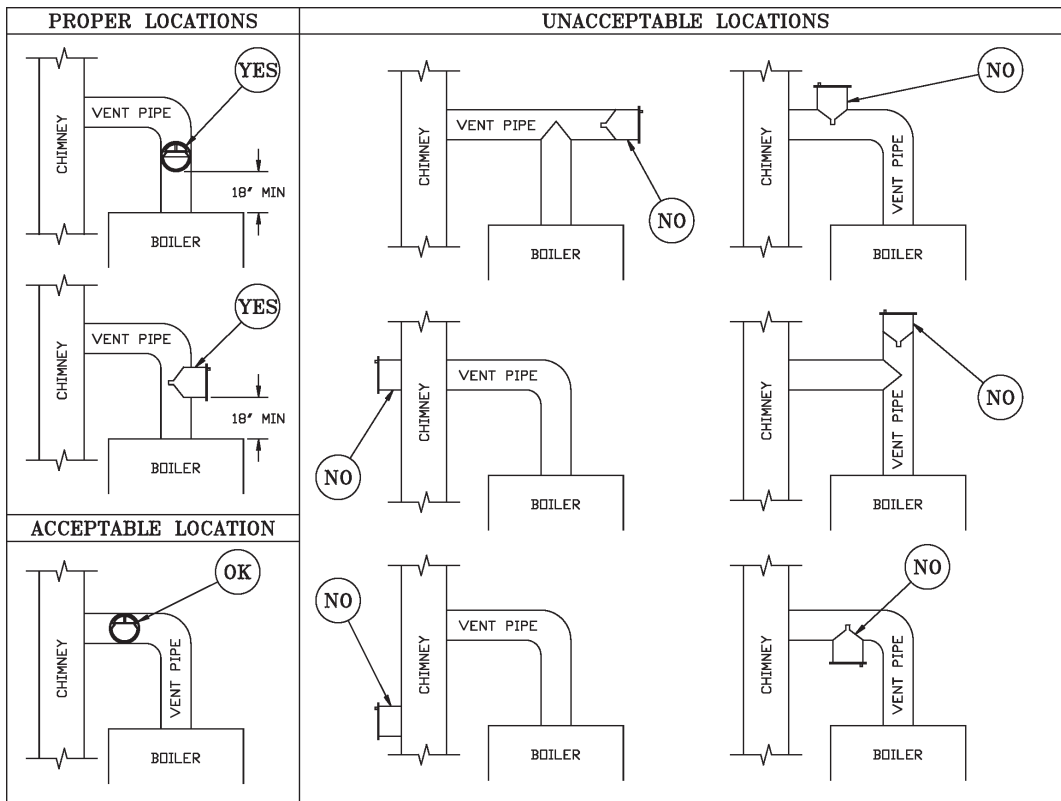

**Figure 5-2: Proper and Improper Locations of Draft Regulator**

## 5 Venting (continued)

- d. Clean Chimney – Chimney shall be free of all loose debris.
5. Draft Regulator – the draft regulator must be used with this appliance. Refer to Figures 5-1 and 5-2.

### B. CHIMNEY CONNECTOR

1. A chimney connector (vent pipe) is used to connect the boiler to the base of the chimney. The chimney connector should be kept as short as possible. The horizontal length of the chimney connector shall not be greater than 10 feet.

#### DANGER

The chimney and connector shall be inspected annually for signs of debris and corrosion. Loose mortar at the base of the chimney may be a sign of condensate damage to the chimney. A chimney professional shall be contacted immediately to examine the damage and recommend a solution. Long term operation while in this condition may cause a venting failure and force flue gases into the living space. If the chimney is to be re-lined use the recommendations in NFPA 31, Appendix E.

2. Vent Connector shall be any of the following and of the same size as the outlet of boiler.
  - a. Type L or a factory built chimney material that complies with the Type HT requirements of ANSI/UL 103. Install in accordance with listing and manufacturer's instructions.
  - b. Steel pipe having resistance to corrosion and heat with a minimum wall thickness of 24 Gauge (0.024").

#### DANGER

Any sign of condensate seepage at the base of the chimney shall be inspected immediately. The discoloration may be a sign of chimney damage and must be remedied immediately.

### C. DRAFT

1. The natural draft generated through a chimney is dependent on several factors including, chimney height, temperature of flue gases, cross section area of chimney, chimney wall insulation value, dilution air and total volume of flue gases, to name a few. Make sure that the boiler has been running for at least 5 minutes before measuring the draft.
2. Minimum Draft Overfire – The draft induced by a chimney must create at least a pressure of -0.02 inches water column (" w.c.). The pressure at

the canopy **cannot** be positive since this could create a condition that allows flue gas by-products to escape from the draft regulator. A negative pressure reading up to -.03 inches water column is acceptable for proper operation.

### D. STACK TEMPERATURE

1. The temperature of the flue gases has a significant effect on the amount of draft created in a vertical chimney as well as the propensity to create condensate. The higher the stack temperature, the greater the amount of draft that can be generated. A lower stack temperature not only reduces the amount of draft that can be created but it also increases the possibility that the flue gases could condense in the chimney connector or stack.
2. NFPA 31 has information to help the installer make an appropriate choice of venting materials. In some cases a chimney may have to be lined to create sufficient draft. In other cases, the chimney may have to be lined to prevent the corrosion of a masonry chimney. Consult with a chimney specialist knowledgeable on the requirements for chimney requirements in your area.

#### CAUTION

Any doubt on the condition of a chimney or it's ability to prevent the generation and accumulation of flue gas condensate, must be relined according to NFPA 31 (United States).

Use the chimney venting tables as a guide. It is highly recommended that any borderline application should result in the relining of the chimney with a suitable liner that creates sufficient draft and to protect against corrosion caused by flue gas condensate.



## 6 Electrical

### DANGER

Positively assure all electrical connections are unpowered before attempting installation or service of electrical components or connections of the boiler or building. Lock out all electrical boxes with padlock once power is turned off.

### WARNING

- Failure to properly wire electrical connections to the boiler may result in serious physical harm.
- Electrical power may be from more than one source. Make sure all power is off before attempting any electrical work.
- Each boiler must be protected with a properly sized fused disconnect.
- Never jump out or make inoperative any safety or operating controls.
- The primary control may be damaged or may not function properly if 120 volt power supply is NOT wired into control as follows:

The 120V interrupted hot (black) wire must be connected to the primary control black wire, the 120V neutral (white) wire must be connected to the primary control white wire and the 120V constant hot (red) wire must be connected to the primary control red wire.

#### A. GENERAL

1. Install wiring and electrically ground boiler in accordance with requirements of the authority having jurisdiction, or in absence of such requirements the National Electrical Code, ANSI/NFPA 70.
2. Refer to National Electric Code or Local Electric Codes for proper size and type of wire required. Follow Code.
3. A separate electrical circuit must be run from the main electrical service with an over-current device/disconnect in the circuit. A service switch is recommended and may be required by some local jurisdictions.
4. Use anti-short bushings on all wiring passing through boiler jacket, junction boxes and/or control boxes.
5. Use armored cable (BX) over all exposed line voltage wiring.
6. If an indirect domestic water heater is used, use priority zoning. **DO NOT** use priority zoning for Hydro-Air Systems.
7. Wiring should conform to Figures 6-1 and 6-2.

- B. INSTALL A ROOM THERMOSTAT on an inside wall about four feet above floor. Never install thermostat on an outside wall or where it will be influenced by drafts, hot or cold water pipes, lighting fixtures, television, rays of the sun or near a fireplace. Keep large furniture away from thermostat so there will be free movement of room air around this control.

# 6 Electrical (continued)

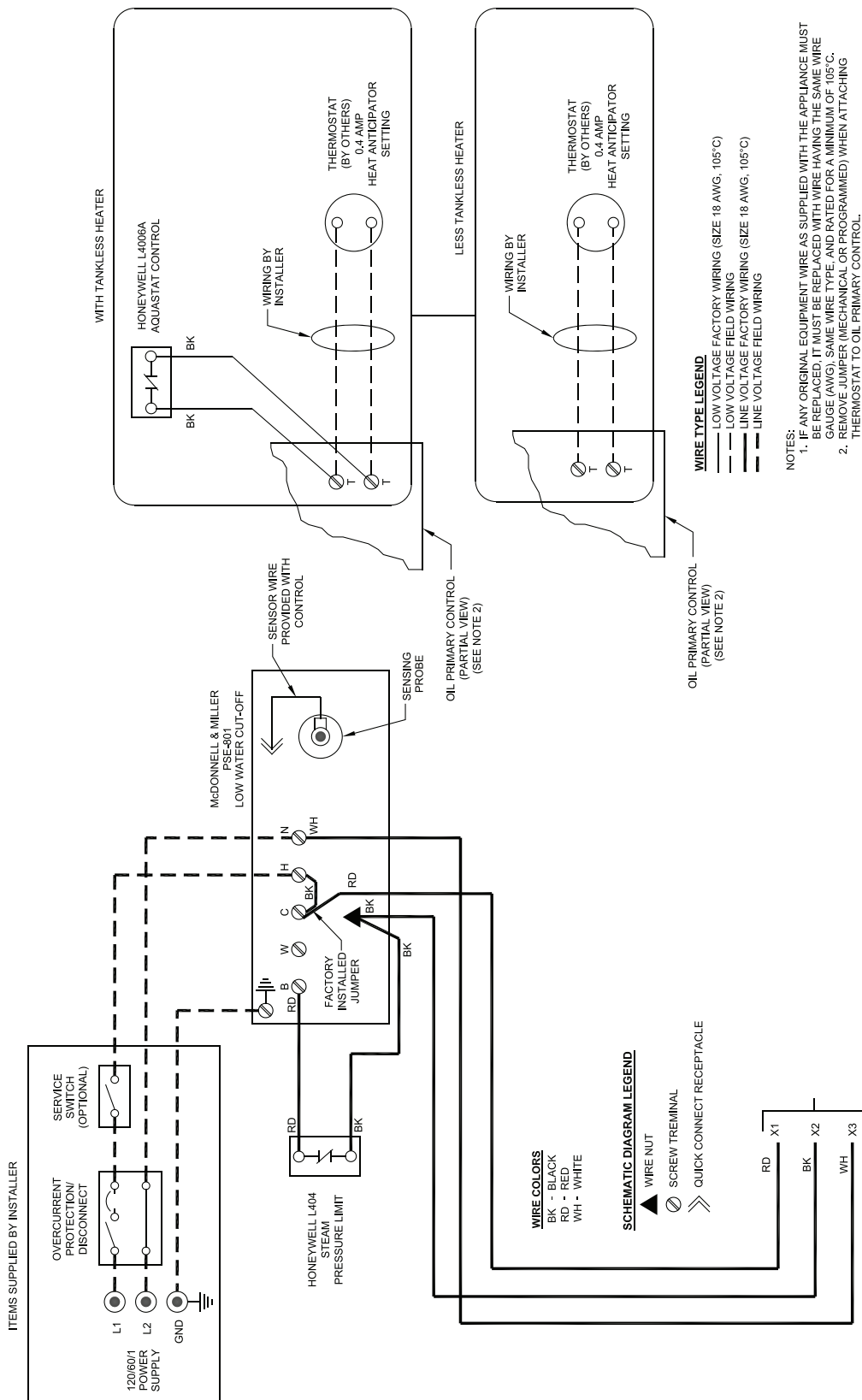
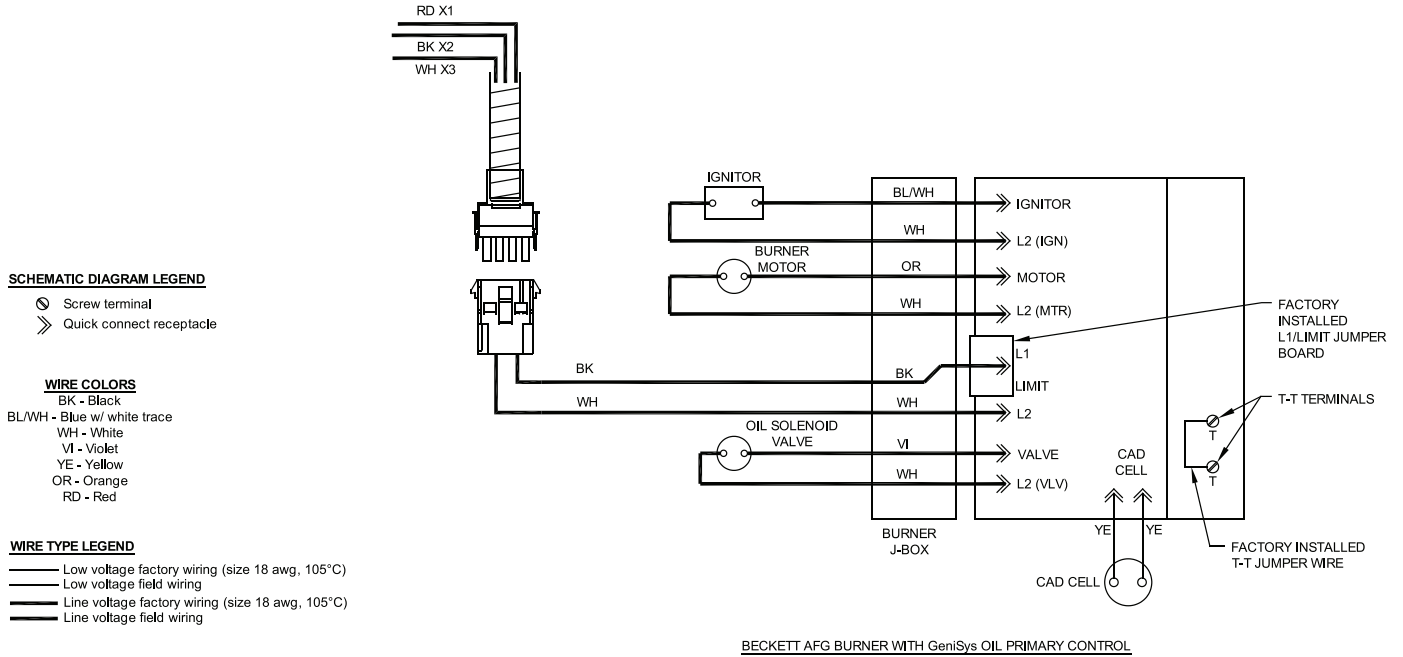
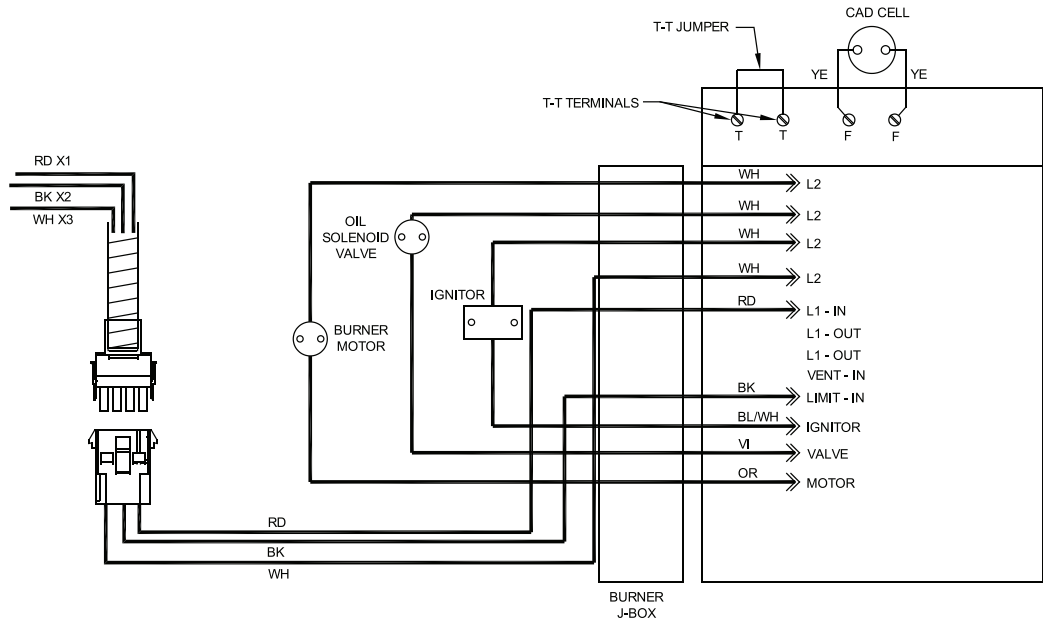

Figure 6-1: Schematic Wiring Diagram, Steam Boiler, McDonnell & Miller PSE-801 Probe LWCO (All Burner Options)

# 6 Electrical (continued)



- Notes:
1. If any original equipment wire as supplied with the appliance must be replaced, it must be replaced with wire having the same wire gauge (awg), same wire type, and rated for a minimum of 105°C.



## 7 Oil Piping

### A. GENERAL

1. Use flexible oil line(s) so the burner swing door can be opened without disconnecting the oil supply piping.
2. A supply line fuel oil filter is recommended as a minimum for all firing rates but a pleated paper fuel oil filter is recommended for the firing rates below 1.0 GPH to prevent nozzle fouling.
3. Use Flared fittings only. Cast iron fittings cannot be used.

**NOTICE** DO NOT use compression fittings.

**Oil piping must be absolutely airtight or leaks or loss of prime may result. Bleed line and fuel unit completely.**

**Refer to your local jurisdictions regarding any special considerations for fuel supply requirements. In addition, refer to NFPA 31, Standard for the Installation of Oil-Burning Equipment for Installations in the United States and CSA B139-04 for Installation in Canada.**

4. Use of a high efficiency micron filter (Garber or equivalent) in addition to a conventional filter is highly recommended.
5. Piping used to connect the oil burner to the oil supply tank shall not be smaller than 3/8" iron pipe or 3/8" OD copper tubing. Copper tubing shall have a .032" minimum wall thickness.

### ⚠ WARNING

Under no circumstances can copper with sweat style connectors be used.

**NOTICE** Some jurisdictions require the use of a fusible shutoff valve at the tank and/or the burner. In addition, some jurisdictions require the use of a fusible electrical interlock with the burner circuit. Check your local Codes for special requirements.

### B. SINGLE PIPE OIL LINES

1. Standard burners are provided with single-stage 3450 RPM fuel units with the bypass plug removed for single-pipe installations.
2. The single-stage fuel unit may be installed single-pipe with gravity feed or lift. Maximum allowable lift is 8 feet. See Figure 7-1.
3. Fuel Oil Line Deaerator – On many occasions a leaky oil delivery line can introduce air into the fuel oil supply system. This often creates a rough starting condition and can create a burner lockout state. In addition to fixing the leak, a fuel line deaerator can be installed to eliminate air. The single line from the fuel tank is connected to the deaerator. The burner pump must be connected to the deaerator as a two pipe system. Follow the oil pump manufacturer's recommendations for conversion to a two pipe system.

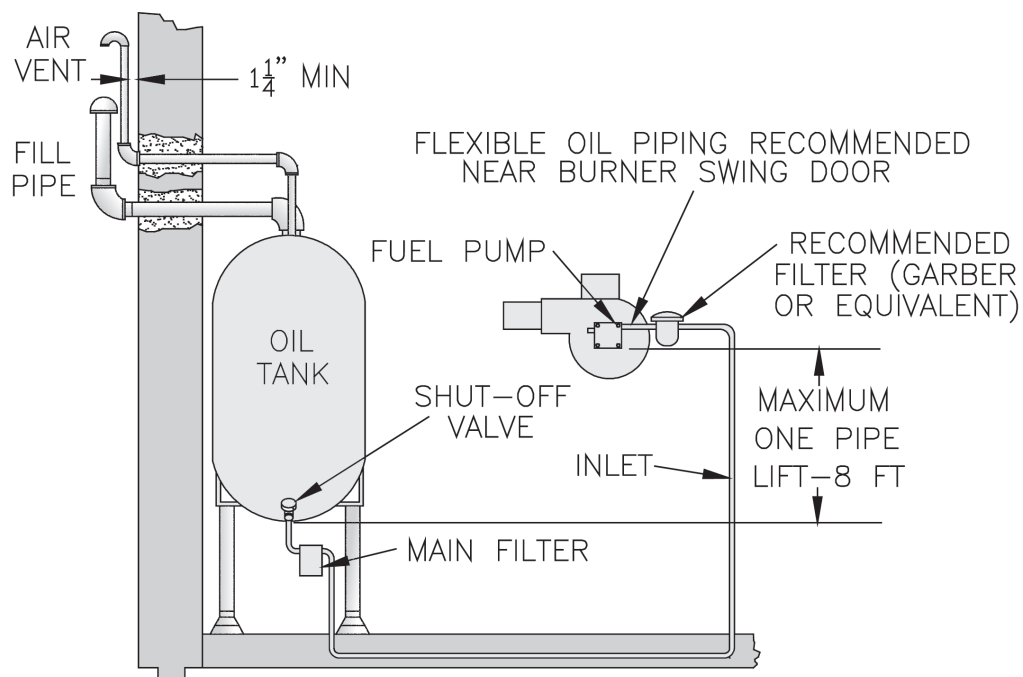

Figure 7-1: Single Pipe Oil Line

# 7 Oil Piping (continued)

## C. TWO PIPE OIL LINES

- For two piped systems, where more lift is required, the two-stage fuel unit is recommended.

Table 7-2 (two-stage) and Table 7-3 (single-stage) show allowable lift and lengths of 3/8 inch and 1/2 inch OD tubing for both suction and return lines. Refer to Figure 7-4.

**Table 7-2: Two-Stage Units (3450 RPM) - Two Pipe Systems**

Lift "H" (See Fig. 25)	Maximum Length of Tubing "H" + "R" (See Figure 27)	
	3/8" OD Tubing (3 GPH)	1/2" OD Tubing (3 GPH)
0'	93'	100'
2'	85'	100'
4'	77'	100'
6'	69'	100'
8'	60'	100'
10'	52'	100'
12'	44'	100'
14'	36'	100'
16'	27'	100'
18'	---	76'

**Table 7-3: Single-Stage Units (3450 RPM) - Two Pipe Systems**

Lift "H" (See Fig. 25)	Maximum Length of Tubing "H" + "R" (See Figure 27)	
	3/8" OD Tubing (3 GPH)	1/2" OD Tubing (3 GPH)
0'	84'	100'
1'	78'	100'
2'	73'	100'
3'	68'	100'
4'	63'	100'
5'	57'	100'
6'	52'	100'
7'	47'	100'
8'	42'	100'
9'	36'	100'
10'	31'	100'
11'	26'	100'
12'	21'	83'
13'	---	62'
14'	---	41'

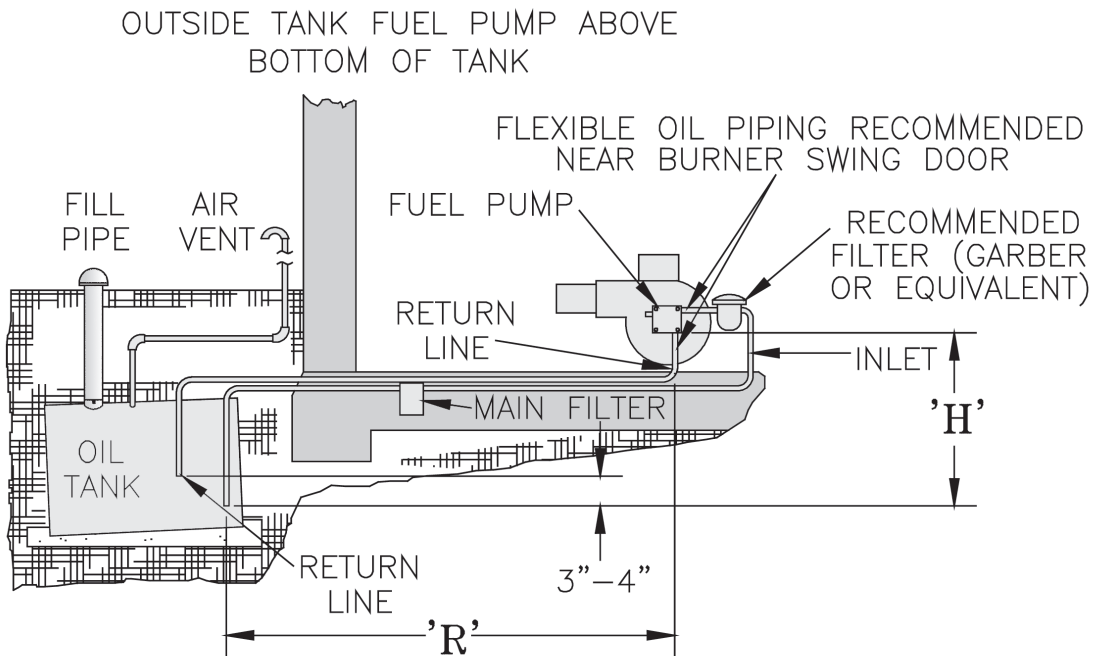

**Figure 7-4: Two Pipe Oil Lines**

## 8 System Start-Up

### WARNING

All boilers equipped with burner swing door have a potential hazard which can cause severe property damage, personal injury or loss of life if ignored. Before opening swing door, turn off service switch to boiler to prevent accidental firing of burner outside the combustion chamber. Be sure to tighten swing door fastener completely when service is completed.

- A. ALWAYS INSPECT INSTALLATION BEFORE STARTING BURNER.
1. Verify that the venting, water piping, oil piping, and electrical system are installed properly. Refer to Installation Instructions contained in this manual.
  2. Confirm all electrical, water and oil supplies are turned off at the source and that the vent is clear from obstructions.

### WARNING

Completely read, understand and follow all instructions in this manual before attempting start up.

- B. FILL HEATING SYSTEM WITH WATER.

**NOTICE** It is important, especially in a steam system, to properly remove the oil and dirt from the system. Failure to clean the system can result in erratic water lines and surging.

CLEAN HEATING SYSTEM if boiler water or condensate return water is dirty or if erratic water lines or surging exist after a few days of boiler operation.

Refer to Maintenance and Service Instructions Section of this manual for proper cleaning instructions for steam boilers.

1. STEAM BOILERS — Fill boiler to normal water line. Refer to Figure 1-1.



is posted on the ASME Data Label located on the top of the boiler. Never exceed this pressure. **DO NOT** plug safety or relief valve.

- C. CHECK CONTROLS, WIRING AND BURNER to be sure that all connections are tight and burner is rigid, that all electrical connections have been completed and fuses installed, and that oil tank is filled and oil lines have been tested.
- D. ADJUST CONTROL SETTINGS with burner service switch turned "ON".
1. SET ROOM THERMOSTAT about 10°F below room temperature.

2. PRESS RED RESET BUTTON on front of Primary Control, hold button for one (1) second and release to reset primary control.

3. STEAM BOILERS:

With an L404F Pressure Limit - set cut-out pressure (MAIN scale) on the pressure limit for (1) PSI and differential pressure (DIFF.) for .5 PSI. These pressures may be varied to suit individual requirements of the system.

4. STEAM BOILERS WITH TANKLESS DOMESTIC WATER HEATERS, set boiler water temperature dial on L4006 operating control at 190°F (max.). Set differential at 10°.

5. CHECKOUT

Put the system into operation and observe at least one complete cycle to make sure that the controller operates properly. See Troubleshooting Section to use LED to assist in determining system operation.

- E. ADJUST OIL BURNER BEFORE STARTING.

1. CHECK BURNER SETTINGS and readjust if necessary, see Burner Specifications, Table 12 at the rear of this manual.

- F. START OIL BURNER.

1. Open vent fitting on fuel pump.
2. TURN 'ON' BURNER service switch and allow burner to run until oil flows from vent fitting in a SOLID stream without air bubbles for approximately 10 seconds.
3. Close vent fitting and burner flame should start immediately after prepurge is completed. Prepurge prevents burner flame until 10 seconds has elapsed after initial power is applied to burner. During prepurge the motor and igniter will operate but the oil valve will remain closed. Refer to Oil Primary Control Instructions for more details.
4. Adjust oil pressure.
  - a. When checking a fuel unit's operating pressure, a reliable pressure gauge may be installed in either the bleeder port or the nozzle port. Refer to Figure 8-1.
  - b. Locate oil pressure adjusting screw and turn screw to obtain proper pump pressure, refer to Tables 14-1 and 14-2 at the rear of this manual.

## 8 System Start-Up *(continued)*

- c. To check the cutoff pressure, deadhead a reliable pressure gauge onto the copper connector tube attached to the nozzle port. Run the burner for a short period of time. Shut the burner off. The pressure should drop and hold.
  - d. Remove the gauge and install bleeder port and/or reconnect the nozzle port line.
- G. ADJUST OIL BURNER WHILE OPERATING. (flame present)
1. SET ROOM THERMOSTAT about 10°F below room temperature.
  2. PRESS RED RESET BUTTON on Oil Primary Control and release.
  3. READJUST THE HEAD SETTING only if necessary.
  4. ADJUST DRAFT REGULATOR for a draft of -0.02" (water gauge) over the fire after chimney has reached operating temperature and while burner is running.

### WARNING

DO NOT loosen or remove any oil line fittings while burner is operating.

5. READJUST THE AIR SETTING on the burner for a light orange colored flame while the draft over the fire is -0.02". Use a smoke tester and adjust air for minimum smoke (not to exceed #1) with a minimum of excess air. Make final check using suitable instrumentation to obtain a CO<sub>2</sub> of 11.5 to 13.0% with draft of -0.02" (water gauge) in fire box. These settings will assure a safe and efficient operating condition. If the flame appears stringy instead of a solid fire, try another nozzle of the same type. Flame should be solid and compact. After all adjustments are made, recheck for a draft of -0.02" over the fire.
6. FLAME FAILURE  
The CL boiler controls operate the burner automatically. If for unknown reasons the burner ceases to fire and the reset button on the primary control has tripped, the burner has experienced ignition failure. Refer to Oil Primary Control features, Paragraph I, Step 2 of this Section and Section XV, Troubleshooting, Paragraph B. If the failure re-occurs, call your heating contractor immediately before pressing the reset button.

- H. CHECK FOR CLEAN CUT OFF OF BURNER.
  1. AIR IN THE OIL LINE between fuel unit and nozzle will compress when burner is on and will expand when burner stops, causing oil to squirt from nozzle at low pressure as burner slows down and causing nozzle to drip after burner stops. Usually cycling the burner operation about 5 to 10 times will rid oil line of this air.
  2. IF NOZZLE CONTINUES TO DRIP, repeat Paragraph H, No. 1 above. If this does not stop the dripping, remove cut-off valve and seat, and wipe both with a clean cloth until clean, then replace and readjust oil pressure. If dripping or after burn persist replace fuel pump.
- I. TEST CONTROLS.
  1. Check thermostat operation. Raise and lower thermostat setting as required to start and stop burner.

### WARNING

Before installation of the boiler is considered complete, the operation of all boiler controls must be checked, particularly the primary control and high limit control.

2. VERIFY OIL PRIMARY CONTROL FEATURES using procedures outlined in Instructions furnished with control or burner:

### WARNING

Cad Cell Jumper must be removed after this check.

3. CHECK HIGH LIMIT
  - a. Adjust system thermostat(s) to highest setting.
  - b. Allow burner to run until boiler water temperature exceeds high limit setting. The burner should shut down and circulators continue running.
  - c. Allow the temperature to drop below control setting. The burner must restart.
  - d. Boiler installation is not considered complete until this check has been made.

## 8 System Start-Up *(continued)*

- e. Check low water cut-off control with water level at normal water line (see Figure 1-1). Raise thermostat setting to allow burner to operate. Open boiler drain to allow water level to drop to bottom of sight glass until burner operation is shut-down by low water cut-off. Close boiler drain and refill to normal water line. Burner should automatically restart during fill. Lower thermostat setting.
  - f. Check operating control on boiler applications equipped with tankless heater(s). With burner off, draw hot water until burner starts, then turn off hot water and check burner shut-down.
- J. IF CONTROLS MEET REQUIREMENT outlined in Paragraph I.
1. Allow boiler to operate for approximately 30 minute, confirm the boiler and system have no leaks.
- K. IF CONTROLS DO NOT MEET REQUIREMENTS outlined in Paragraphs I-1 thru I-6, replace control and repeat checkout procedures.

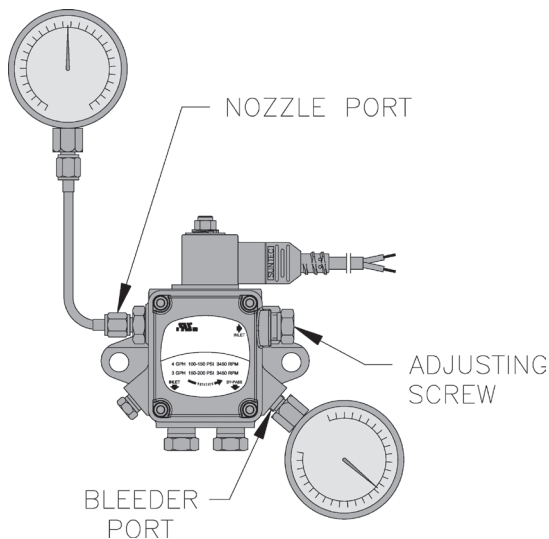

**Figure 8-1: Adjusting Fuel Pump Pressure**



## 9 Operating

### A. STEAM BOILERS SEQUENCE OF OPERATION

Upon a thermostat call for heat, when provided, the R8239A Control Center Relay or the Oil Primary Control is energized when the steam pressure is below the L404F Pressure Limit and water level is above the Low Water Cut-Off. When energized the Oil Primary Control starts the burner as follows; blower is started and operates for a pre-purge time; spark is energized and fuel valve is opened for ignition trail time; the fuel valve remains open when flame is proven. The burner fires until the thermostat is satisfied or the Pressure Limit setting is reached. The Oil Primary Control stops the burner by closing the fuel valve and operating the blower for post-purge time. Upon a drop in pressure, steam pressure below the L404F Pressure Limit, the burner will re-start if the thermostat is still calling for heat. When there is a tankless heater included and there is no demand for heat, the L4006A operating control will maintain the boiler water temperature at the selected setting for proper operation of the domestic water heater.

The probe low water cut-off will shut down the burner after a 10 second delay, if the water level in the boiler drops below the probe level. If the water level is too low the burner will not be allowed to restart. The low water cut-off will reset and restart the burner with a call for heat 30 seconds after the water is returned to its normal level.

On burner start, if the CAD cell does not see flame within approximately 15 seconds, primary control will shut down the burner and enter into a lockout mode. A lockout is reset by pressing the reset button located on the primary control. If the flame is lost while the burner is firing, the primary control shuts down the burner, enters a 60 second recycle delay, and repeats the ignition sequence. If after three (3) trials for ignition, flame is not detected, primary control will enter into restricted mode. Restricted mode is reset by holding down the reset button for 15 seconds.

## 9 Operating *(continued)*

### Important Product Safety Information: Refractory Ceramic Fiber Product

#### WARNING

**Some boiler components use materials that contain refractory ceramic fibers (RCF). RCF has been classified as a possible human carcinogen. When exposed to elevated temperatures, RCF may change into crystalline silica, a known carcinogen. When disturbed as a result of servicing or repair, these substances become airborne and, if inhaled, may be hazardous to your health. Avoid breathing RCF particulates and dust.**

#### Precautionary Measures:

- Do not handle RCF parts or attempt any service or repair work involving RCF without wearing the following protective gear:
  1. A properly fitting National Institute for Occupational Safety and Health (NIOSH)-certified air-purifying respirator with a filter efficiency of at least 95%. Respirator should also include a full facepiece when handling used RCF. Other types of respirators may be required depending on site conditions. Current NIOSH recommendations may be found on the NIOSH website <http://www.cdc.gov/niosh/homepage.html>. NIOSH-approved manufacturers, respirators and associated user instructions are listed on the NIOSH website.
  2. Long sleeved, loose fitting clothing that is sufficiently tight around potential entry points for RCF dust.
  3. Gloves.
  4. Eye protection, such as goggles, safety glasses with side shields, or full facepiece.
- Take steps to assure adequate ventilation.
- Handle RCF carefully to minimize airborne dust. Use hand tools whenever possible.
- Dampen used RCF with light water spray prior to removal to prevent airborne dust.
- Do not use compressed air or dry sweeping for clean-up. Frequently clean work area with a vacuum or by wet sweeping to minimize debris accumulation.
- Vacuum work clothes before leaving work area. Wash work clothes separately from other laundry and rinse washing machine after use to avoid contaminating other clothes.
- Wash all exposed body areas gently with soap and water after contact.
- Discard used RCF components by sealing in an airtight plastic bag or container. Refer to local, regional, state or provincial regulations to identify applicable disposal requirements.

#### First Aid Procedures:

- Eye contact: Flush with water for at least 15 minutes. Do not rub eyes. Seek immediate medical attention if irritation persists.
- Skin contact: Wash affected area gently with soap and water. Do not rub or scratch affected skin. Seek immediate medical attention if irritation persists.
- Nose and throat contact: If these become irritated, leave the area and move to a location with clean fresh air. Drink water and blow nose. Seek immediate medical attention if symptoms persist.

# 10 Maintenance and Service Instructions

## A. MAINTENANCE OF LOW WATER CUT-OFF DEVICES

### WARNING

Probe and float type low water cut-off devices require annual inspection and maintenance.

#### 1. PROBE TYPE LOW WATER CUT-OFF

Although these devices are solid state in their operation, the probe is exposed to possible contamination in the boiler water and subject to fouling.

It is important to physically remove the probe from the boiler tapping annually and inspect that probe for accumulation of scale or sediment.

Follow these steps to inspect, clean and/or replace the probe:

- a. Turn off electric service to the boiler.
- b. Drain boiler water to a level below the tapping for the probe.
- c. Disconnect wiring connections between the low water cut-off control and the probe.
- d. Remove the low water cut-off control from the probe.

### DANGER

Assure that the boiler is at zero pressure before removing the LWCO probe. **DO NOT** rely on the pressure gauge to indicate that the boiler is at zero pressure. Open the safety valve to relieve all internal pressure prior to proceeding. Safety valve discharge piping must be piped such that the potential for burns is eliminated.

- e. Unscrew the probe from the boiler tapping.
- f. Inspect that portion of the probe that is exposed to the boiler water for a scale or sediment buildup.
- g. Light deposits may be removed by wiping the probe with a damp cloth. Wiping the probe with a cloth soaked in vinegar will remove more tenacious lime deposits. The most stubborn deposits may be removed from the probe by using a diluted amount, 3 parts of water to 1 part of phosphoric acid ( $H_2PO_4$ ).

### CAUTION

Exercise caution when handling phosphoric acid and follow the instruction label on its container.

- h. Clean the pipe threads of the probe to remove old, hardened pipe dope and other foreign matter.

- i. Apply a moderate amount of good quality pipe dope to the pipe threads on the probe, leaving the two end threads bare. **DO NOT** use PTFE (Teflon) tape.
- j. Screw the probe into the boiler tapping.
- k. Mount the low water cut-off control on the probe.
- l. Reconnect the control to probe wiring.
- m. Fill the boiler to its normal waterline.
- n. Add boiler water treatment compound as needed (refer to Paragraph B.).
- o. Restore electric service to the boiler.
- p. Fire burner to bring the water in the boiler to a boil to drive off free oxygen.
- q. **WARNING — BEFORE RETURNING BOILER TO SERVICE:** Follow the low water cut-off check out procedure in Section X, Paragraph I, No. 4.

## B. BOILER AND SYSTEM CLEANING INSTRUCTIONS FOR TROUBLE FREE OPERATION

### 1. STEAM BOILERS

- a. Oil, greases & sediments which accumulate in a new boiler and piping must be removed in order to prevent an unsteady water line and carry over of the water into the supply main above boiler.

Operate the boiler with steam in the entire system for a few days allowing the condensate to return to the boiler. If the condensate can temporarily be wasted, operate boiler only for the length of time it takes for condensate to run clear. If the latter cannot be achieved or if the condensate is returned to the boiler, boil out the boiler using the SURFACE BLOW-OFF connection, see Figure 5 (tappings, J).

- i. Drain boiler until 1" of water is visible in gauge glass. Run temporary 1½" NPT pipe line from the surface blow-off connection to an open drain or some other location where hot water may be discharged safely. **DO NOT** install valve in this line.
- ii. Drain about 5 gallons of hot water from boiler into a container and dissolve into it an appropriate amount of recommended boil out compound. Remove safety valve & add solution to boiler water thru exposed tapping using a funnel.



## 10 Maintenance and Service Instructions *(continued)*

- e. Make pH or Alkalinity Test.  
After boiler and system have been cleaned and refilled as previously described, test the pH of the water in the system. This can easily be done by drawing a small sample of boiler water and testing with hydrion paper which is used in the same manner as litmus paper, except it gives specific readings. A color chart on the side of the small hydrion dispenser gives the reading in pH. Hydrion paper is inexpensive and obtainable from any chemical supply house or through your local druggist. The pH should be higher than 7, but lower than 11. Add some of the washout chemical (caustic soda), if necessary, to bring the pH within the specified range.
- f. Boiler is now ready to be put into service.

### C. EXCESSIVE MAKE-UP WATER

#### IMPORTANT

**IF, DURING NORMAL OPERATION, IT IS NECESSARY TO ADD MORE WATER THAN INDICATED BELOW, CONSULT A QUALIFIED SERVICE TECHNICIAN TO CHECK YOUR SYSTEM FOR LEAKS.**

Boiler Series	Gallons Per Month	Gallons Per Year
CL3	0.3	4
CL4	0.4	5
CL5	0.5	6

A leaky system will increase the volume of make-up water supplied to the boiler which can significantly shorten the life of the boiler. Entrained in make-up water are dissolved minerals, salts and oxygen. When the fresh, cool make-up water is heated in the boiler the minerals fall out as sediment, the salts coat the inside of the boiler, and the oxygen escapes as a gas. The accumulation of sediment eventually isolates the water from contacting the cast iron. When this happens the cast iron in that area gets extremely hot and eventually cracks. The presence of free oxygen or chloride salts in the boiler corrodes the cast iron from the inside. More make-up water and higher concentrations of contaminants damage the boiler sooner. **Our warranty does not cover corrosion and sediment-related damage.** Clearly it is in everyone's best interest to prevent this type of failure. You can do your part by ensuring that your system is leak-free, keeping leakage to less than 2 percent of the boiler water volume each month.

### D. ATTENTION TO BOILER WHILE NOT IN OPERATION.

**NOTICE** If boiler is not used during winter time, it must be fully drained to prevent freeze damage.

1. Spray inside surfaces with light lubricating or crankcase oil using gun with extended stem so as to reach all corners.
2. With steam boilers, at end of season add sufficient water to fill boiler to top of water column and leave it that way until fall when water should be drained again to proper level. If at this time boiler water is dirty, drain water, flush out boiler, and refill with clean water to prescribed water level.
3. Always keep the manual fuel supply valve shut off if the burner is shut down for an extended period of time.
4. To recondition the heating system in the fall season after a prolonged shut down, follow the instructions outlined in Section X, Paragraphs A through K.

#### WARNING

This boiler contains controls which may cause the boiler to shut down and not restart without service. If damage due to frozen pipes is a possibility, the heating system should not be left unattended in cold weather; or appropriate safeguards and alarms should be installed on the heating system to prevent damage if the boiler is inoperative.

# 11 Boiler Cleaning

## WARNING

All boiler cleaning must be completed with burner service switch turned off. Boilers equipped with burner swing door have a potential hazard which can cause severe property damage, personal injury or loss of life if ignored. Before opening swing door, turn off service switch to boiler to prevent accidental firing of burner outside the combustion chamber. Be sure to tighten swing door fastener completely when service is completed.

### A. CLEAN THE FLUEWAYS (See Figure 11-1).

1. Prior to cleaning boiler, lay a protective cloth or plastic over combustion chamber blanket to collect debris falling from flueways. Several models **DO NOT** utilize a combustion chamber blanket, see Section XIV, Repair Parts, Item 1 Bare Boiler Assembly for details.
2. For access to combustion chamber remove two (2) 5/16" - 18 cap screws, one on the right (1 1/4" long) and one on the left (3 1/4" long). If boiler is equipped with flexible fuel line(s), swing door open.
3. For cleaning from the top:
  - a. Remove as much vent pipe as necessary to allow removal of the jacket top panel and canopy.
  - b. Remove the jacket top panel.
  - c. Remove the canopy, being careful not to damage the gasket.
4. Using a 1 1/4" diameter wire or fibre bristle brush (30" handle) clean the flueways. Brush from the top and/or side using horizontal and diagonal strokes for best results. **DO NOT** allow brush to strike the target wall or liner in the chamber.

### B. CLEAN TOP OF BOILER SECTIONS

Brush and vacuum the tops of the boiler sections.

### C. CLEAN THE COMBUSTION CHAMBER.

Using wire or fibre bristle brush, clean crown of boiler and inside of water legs.

## WARNING

**DO NOT** allow brush to strike target wall or blanket in the combustion chamber.

- D. AFTER CLEANING, remove protective cloth or plastic with debris and vacuum as necessary, but be careful not to damage blanket. Inspect target wall, combustion chamber blanket, burner swing door insulation, and rope gasket for signs of damage. If damaged, replace as needed.
- E. REASSEMBLE BOILER.

## CAUTION

**DO NOT** start the burner unless canopy, vent pipe, burner swing door and all flue cover plates are secured in place.

1. Install the canopy taking care to align the gasket without blocking the flueways. If gasket is damaged, replace as needed.
2. Reinstall jacket top panel with #8 x 1/2" long sheet metal screws.
3. Reinstall vent pipe on canopy and secure to collar with sheet metal screws.
4. Close burner swing door. Secure door to front section with 5/16" flange nut and washer (right side) and 5/16" x 3 1/2" lg. bolt (left side).

**NOTICE** When securing burner swing door make sure door is drawn-in equally on both sides.

Tighten swing door hardware to provide adequate seal to rope gasket around perimeter of door.

Use an alternating tightening method from right side flange nut to left side cap screw to pull door tight equally.

## 11 Boiler Cleaning *(continued)*

### NOTES:

1. PRIOR TO CLEANING BOILER, LAY A PROTECTIVE CLOTH OR PLASTIC OVER THE BLANKET TO COLLECT DEBRIS FALLING FROM FLUEWAYS.
2. AFTER CLEANING, INSPECT TARGET WALL, COMBUSTION CHAMBER BLANKET AND BURNER SWING DOOR INSULATION FOR SIGNS OF DAMAGE. IF DAMAGED, REPLACE AS NEEDED.
3. REPLACE CANOPY GASKET STRIPS AS NEEDED IF DAMAGED.

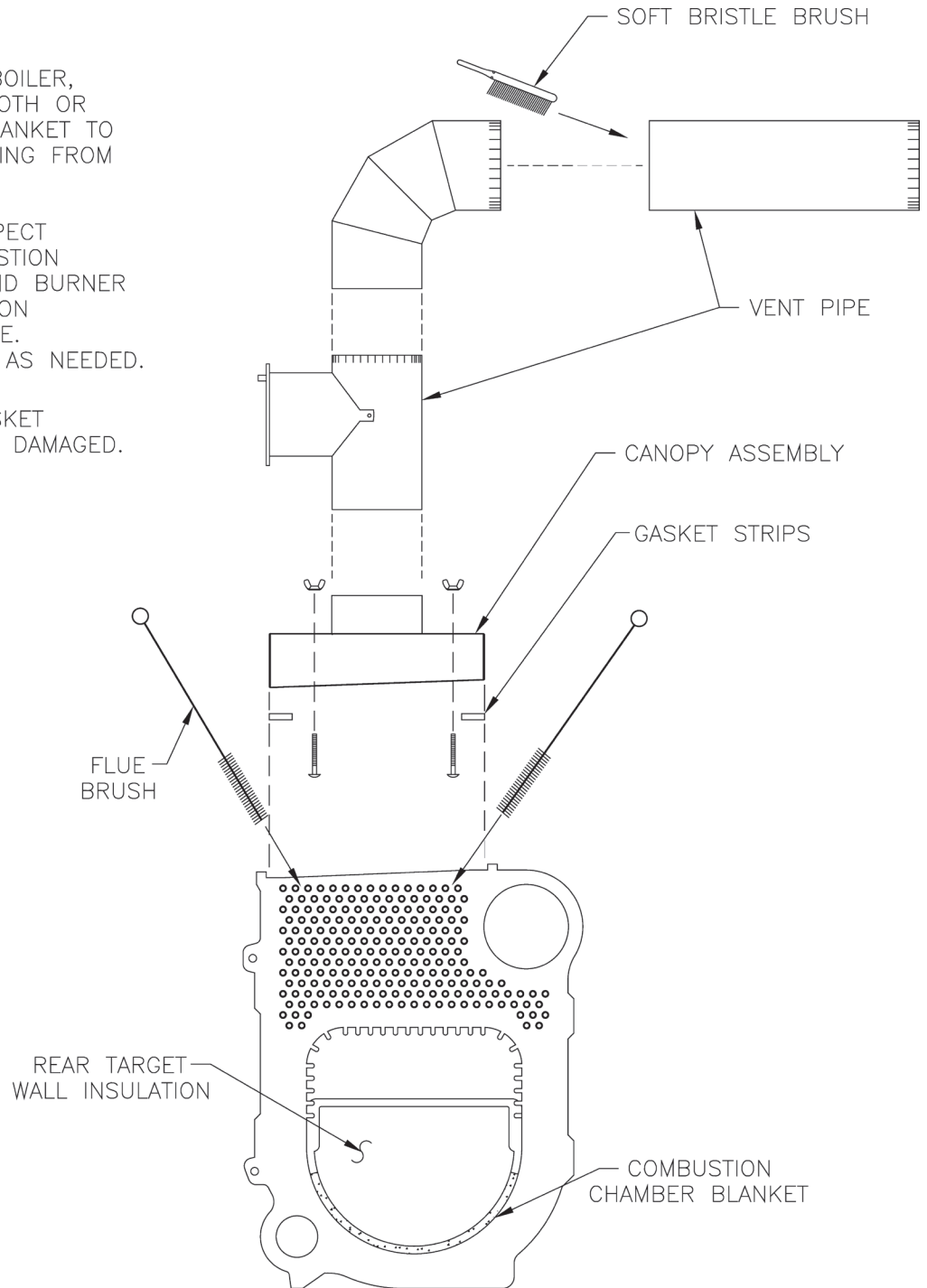

**Figure 11-1: Cleaning of Boiler Flueways**

### **⚠ WARNING**

The boiler must be connected to an approved chimney in good condition. Serious property damage could result if the boiler is connected to a dirty or inadequate chimney. The interior of the chimney flue must be inspected and cleaned before the start of the heating season and should be inspected periodically throughout the heating season for any obstructions. A clean and unobstructed chimney flue is necessary to allow noxious fumes that could cause injury or loss of life to vent safely and will contribute toward maintaining the boiler's efficiency.

# 12 Troubleshooting

## A. COMBUSTION

1. **NOZZLES** — Although the nozzle is a relatively inexpensive device, its function is critical to the successful operation of the oil burner. The selection of the nozzle supplied with the CL boiler is the result of extensive testing to obtain the best flame shape and efficient combustion. Other brands of the same spray angle and spray pattern may be used but may not perform at the expected level of CO<sub>2</sub> and smoke. Nozzles are delicate and should be protected from dirt and abuse. Nozzles are mass-produced and can vary from sample to sample. For all of those reasons a spare nozzle is a desirable item for a serviceman to have.
2. **FUEL LEAKS** — Any fuel leak between the pump and the nozzle will be detrimental to good combustion results. Look for wet surfaces in the air tube, under the ignitor, and around the air inlet. Any such leaks should be repaired as they may cause erratic burning of the fuel and in the extreme case may become a fire hazard.
3. **SUCTION LINE LEAKS** — Any such leaks should be repaired, as they may cause erratic burning of the fuel and in extreme cases may become a fire hazard. Whatever it takes, The Oil Must Be Free of Air. This can be a tough problem, but it must be resolved. Try bleeding the pump through a clear tube. There must be no froth visible. There are various test kits available to enable you to look at the oil through clear tubing adapted to the supply line at the pump fitting. Air eliminators are on the market that have potential. Also, electronic sight glasses are being used with good success. At times, new tubing must be run to the tank or new fittings put on. Just make sure you get the air out before you leave.  
Any air leaks in the fuel line will cause an unstable flame and may cause delayed ignition noises. Use only flare fittings in the fuel lines.
4. **GASKET LEAKS** — If 11.5 to 13.0% CO<sub>2</sub> with a #1 smoke cannot be obtained in the breeching, look for air leaks around the burner mounting gasket, observation door, and canopy gasket. Such air leaks will cause a lower CO<sub>2</sub> reading in the breeching. The smaller the firing rate the greater effect an air leak can have on CO<sub>2</sub> readings.
5. **DIRT** — A fuel filter is a good investment. Accidental accumulation of dirt in the fuel system can clog the nozzle or nozzle strainer and produce a poor spray pattern from the nozzle. The smaller the firing rate, the smaller the slots become in the nozzle and the more prone to plugging it becomes with the same amount of dirt.
6. **WATER** — Water in the fuel in large amounts will stall the fuel pump. Water in the fuel in smaller amounts will cause excessive wear on the pump, but more importantly water doesn't burn. It chills the flame and causes smoke and unburned fuel to pass out of the combustion chamber and clog the flueways of the boiler.
7. **COLD OIL** — If the oil temperature approaching the fuel pump is 40°F or lower, poor combustion or delayed ignition may result. Cold oil is harder to atomize at the nozzle. Thus, the spray droplets get larger and the flame shape gets longer. An outside fuel tank that is above grade or has fuel lines in a shallow bury is a good candidate for cold oil. The best solution is to locate the tank near the boiler in the basement utility room or bury the tank and lines deep enough to keep the oil above 40°F. Check environmental issues with local authorities having jurisdiction.
8. **FLAME SHAPE** — Looking into the combustion chamber through the observation port, the flame should appear straight with no sparklers rolling up toward the crown of the chamber. If the flame drags to the right or left, sends sparklers upward or makes wet spots on the target wall, the nozzle should be replaced. If the condition persists look for fuel leaks, air leaks, water or dirt in the fuel as described above.
9. **HIGH ALTITUDE INSTALLATIONS** — Air openings must be increased at higher altitudes. Use instruments and set for 11.5 to 13.0% CO<sub>2</sub>.
10. **START-UP NOISE** — Late ignition is the cause of start-up noises. If it occurs recheck for electrode settings, flame shape, air or water in the fuel lines.
11. **SHUT DOWN NOISE** — If the flame runs out of air before it runs out of fuel, an after burn with noise may occur. That may be the result of a faulty cut-off valve in the fuel pump, or it may be air trapped in the nozzle line. It may take several firing cycles for that air to be fully vented through the nozzle. Water in the fuel or poor flame shape can also cause shut down noises.



## 12 Troubleshooting (continued)

**NOTICE** CHECK TEST PROCEDURE. A very good test for isolating fuel side problems is to disconnect the fuel system and with a 24" length of tubing, fire out of an auxiliary five gallon pail of clean, fresh, warm #2 oil from another source. If the burner runs successfully when drawing out of the auxiliary pail then the problem is isolated to the fuel or fuel lines being used on the jobsite.

### B. OIL PRIMARY CONTROL (Oil Primary)

1. Burner (Oil Primary) will not come on.
  - a. No power to Oil Primary.
  - b. Oil Primary is in lockout or restricted mode. Press reset button for one (1) second to exit lockout. If control has recycled three times within the same call for heat, it will enter into restricted mode. To reset from restricted mode, refer to Section XI, Paragraph I, No. 2 for details.
  - c. CAD cell seeing light.
  - d. CAD assembly defective.
  - e. Control motor relay is stuck closed (see note below).
2. Burner (control) will light, then shut down after a short time, then restart after one (1) minute.
  - a. CAD cell is defective.
  - b. Air leaking into oil line causing flame out.
  - c. Defective nozzle causing flame to be erratic.
  - d. Excessive airflow or draft causing flame to leave burner head.

- e. Excessive back pressure causing flame to be erratic.
3. Control locks out after Trial For Ignition (TFI).
    - a. No oil to burner.
    - b. Shorted electrodes.
    - c. Nozzle clogged.
    - d. Airflow too high.
    - e. Ignitor module defective.
    - f. CAD cell defective.
    - g. Oil valve stuck open or closed.

Note: The Safety Monitoring Circuit (SMC) is designed to provide lockout in the event of a stuck or welded motor relay.

**NOTICE** If flame is not established within 15 seconds of oil valve actuation (known as Trial For Ignition [TFI]) lockout will occur. Lockout is indicated by a red LED solid-on located on the oil primary control. Hard Lockout will occur if the Oil Primary Control locks-out three (3) times during a call for heat. This is indicated by red light reset button solid-on.

**This Page is Intentionally Blank.**

## 13 Service Parts

All CL™ Series repair parts may be ordered through New Yorker Boiler Company, Inc., or its authorized distributors.

Should you require assistance in locating a New Yorker Distributor in your area, or have questions regarding the availability of New Yorker products or repair parts, please contact: New Yorker Boiler Company, Inc., P.O. Box 3005, Lancaster, PA 17604-3005, Attn: Customer Service Department. Visit our website at [www.newyorkerboiler.com](http://www.newyorkerboiler.com)

# 13 Service Parts (continued)

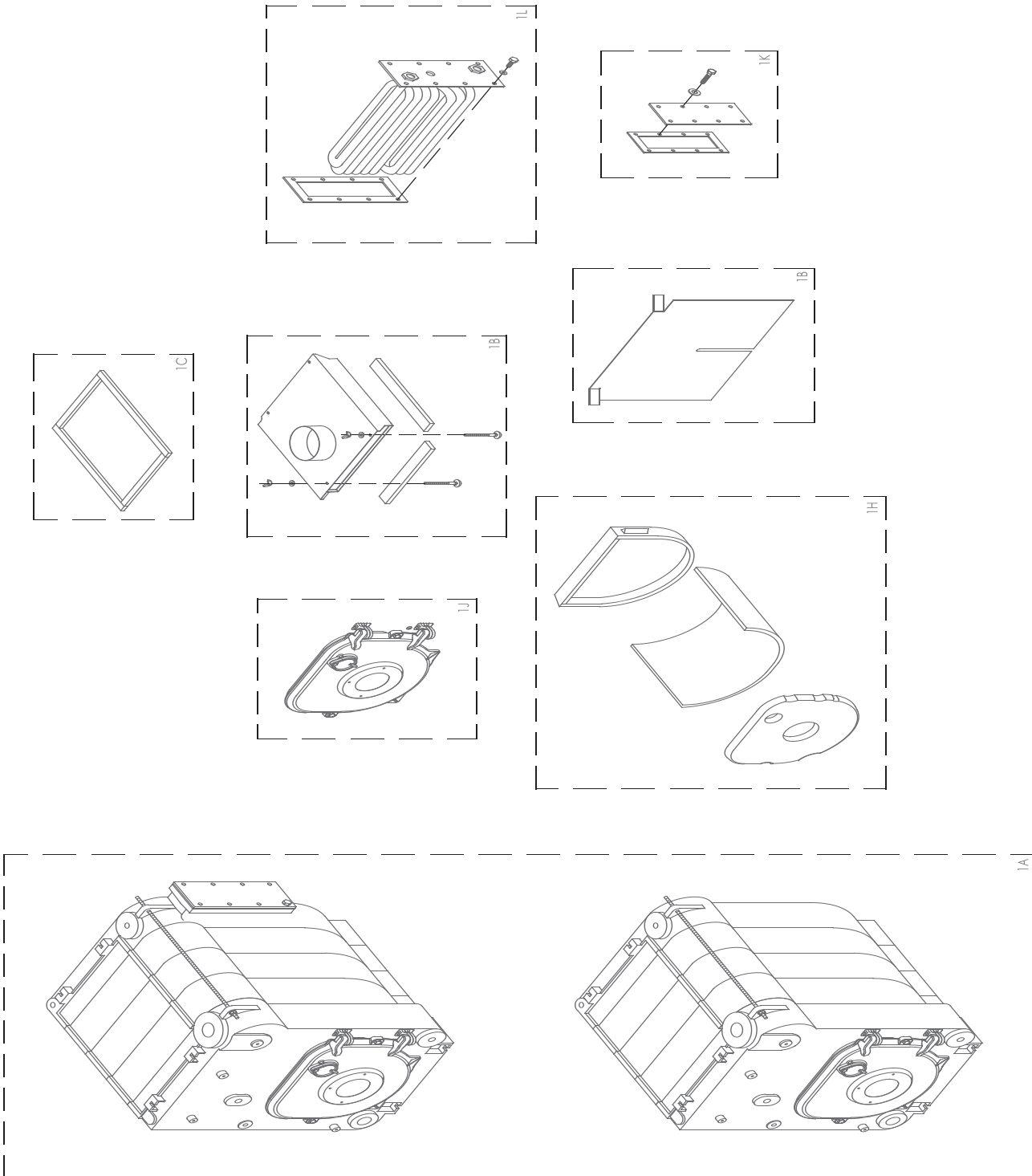

Bare Boiler Assembly

# 13 Service Parts *(continued)*

Item No.	Description	Part No.	CL3	CL4	CL5	
<b>1. BARE BOILER ASSEMBLY</b>						
1A	Block Assembly Carton for Steam, Rear Heater Opening Includes: Complete Block Assembly, Target Wall Insulation, Coil Gasket, Coil Cover Plaste/Hardware	110780-03	1			
		110780-04		1		
		110780-05			1	
	Block Assembly for Steam, Non-Heater Includes: Complete Block Assembly, Target Wall Insulation	110781-03	1			
		110781-04		1		
		110781-05			1	
1B	Canopy Includes: Canopy, Canopy Gasket, and Hardware	110554-03	1			
		110554-04		1		
		110554-05			1	
1C	Canopy Gasket	110272-01	1	1	1	
1G	Flue Baffles	110276-01	2	3	4	
1H	Combustion Chamber Includes: Target Wall Insulation, Combustion Chamber Blanket, and Burner Door Insulation	108471-01	1	1	1	
1J	Burner Swing Door	104140-01	1	1	1	
1K	Heater Cover Plates & Gaskets	Rear Heater-Blank	6036032	1	1	1
		Rear Heater-Tapped	6036033	1	1	1
1L	V1-2 Coil	6036031	1	1	1	

# 13 Repair Parts (continued)

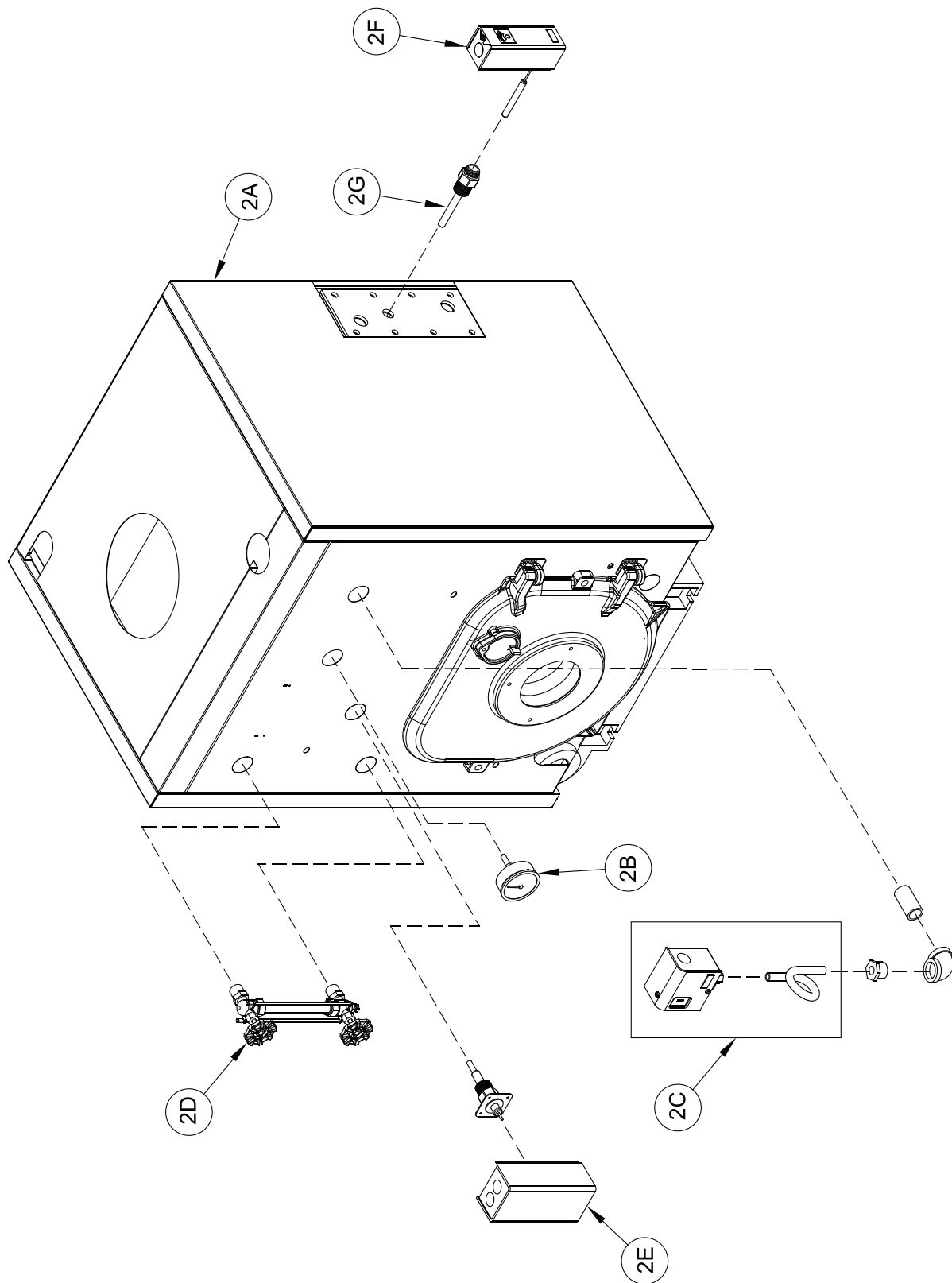

CL Steam Boilers - Trim and Controls

## 13 Service Parts *(continued)*

Item No.	Description	Part No.	CL3	CL4	CL5
2A	Complete Jacket Carton, Rear-Heater	101917-03	1		
		101917-04		1	
		101917-05			1
	Complete Jacket Carton, Non-Heater	101916-03	1		
		101916-04		1	
		101916-05			1
2B	Pressure Gauge, 1/4" NPT x 2 1/2" Dia., 7/8" Lg.	109707-01	1	1	1
2C	Honeywell PA404A1009 Pressuretrol w/ Syphon	110782-01	1	1	1
2D	10-1/4" Gauge Glass Set	110783-01	1	1	1
2E	McDonnell & Miller PSE801-120 LWCO with Probe and Harness	110784-01	1	1	1
	LWCO to Burner Harness	110785-01	1	1	1
2F	Honeywell L4006A2015 Aquastat	110786-01	1	1	1
2G	Immersion Well, 3/4" NPT x 3"	110787-01	1	1	1
Not Shown	Relief Valve, #13-511-B15 12 PSI	Obtain Locally	1	1	1
	Drain Valve, 3/4" NPT, ConBraCo 35-302-03		1	1	1

## 13 Service Parts *(continued)*

Item No.	Description	Part No.	CL3	CL4	CL5	
Not Shown	Beckett	110498-03	1			
		110499-04		1		
		110500-05			1	
	Carlin	110496-03	1			
		110497-04		1		
		106862-01			1	
	Primary Control	Honeywell R7284P1080	103880-01	1	1	1
		Beckett GeniSys 7505p1515	Obtain Locally	1	1	1
		Carlin		1	1	1



# 14 Burner Specifications

**Table 14-1: Becket**

Boiler Model	Firing Rate GPM	Burner Model	Settings			Nozzle	Shipped	Pump Pressure
			Head (Setting)	Air Shutter	Air Band			
CL3-105SE	0.75	AFG	L1	10	2	0.65 x 60B (Hago)	Installed	140
CL3-140SE	1.00			5	2	0.85 x 60B (Hago)	Field Provided	
CL4-168SE	1.20		V1(0)	10	0.5	1.00 x 60B (Hago)	Installed	
CL4-210SE	1.50			10	6	1.25 x 60B (Hago)	Field Provided	
CL5-245SE	1.75		V1(3)	6	6	1.50 x 45B (Hago)	Installed	175
CL5-266SE	1.90		V1(4)	8	4	1.35 x 45B (Hago)	Field Provided	

**Table 14-2: Carlin**

Boiler Model	Firing Rate	Burner Model	Settings		Nozzle	Shipped	Pump Pressure
			Head Bar	Air Band			
CL3-105SE	0.75	EZ-1 HP	0.60/.065	0.6	0.65 x 60A (Delavan)	Installed	150
CL3-140SE	1.00		0.85/1.00	0.75	0.85 x 60B (Delavan)	Field Provided	
CL4-168SE	1.20			1.10/1.10	1.00 x 60A (Delavan)	Installed	
CL4-210SE	1.50		1.10/1.25	1.25/1.35	1.25 x 60B (Delavan)	Field Provided	
CL5-245SE	1.75	EZ-2 HP	1.5	1.75	1.50 x 60A (Delavan)	Installed	
CL5-266SE	1.90						

## Appendix - Aftermarket Low Water Cut Off (LWCO)

### ⚠ WARNING

DO NOT ATTEMPT to cut factory wires to install an aftermarket Low Water Cut Off (LWCO). Only use connections specifically identified for Low Water Cut Off.

In all cases, follow the Low Water Cut Off (LWCO) manufacturer's instructions.

#### When

A low water cutoff is required to protect a hot water boiler when any connected heat distributor (radiation) is installed below the top of the hot water boiler (i.e. baseboard on the same floor level as the boiler). In addition, some jurisdictions require the use of a LWCO with a hot water boiler.

#### Where

The universal location for a LWCO on oil hot water boilers is above the boiler, in either the supply or return piping. The minimum safe water level of a water boiler is at the uppermost top of the boiler; that is, it must be full of water to operate safely.

It is recommended that the LWCO control is installed above the boiler to provide the highest level of protection. However, where the LWCO control is approved by the LWCO control manufacturer for installation in a high boiler tapping of a water boiler, the use of the listed LWCO control is permitted when it is installed according to the LWCO manufacturer's instructions.

#### What Kind

Typically, in residential applications, a probe type LWCO is used instead of a float type, due to their relative costs and the simplicity of piping for a probe LWCO.

#### How to Pipe

A "tee" is commonly used to connect the probe LWCO in the supply or return piping, as shown below.

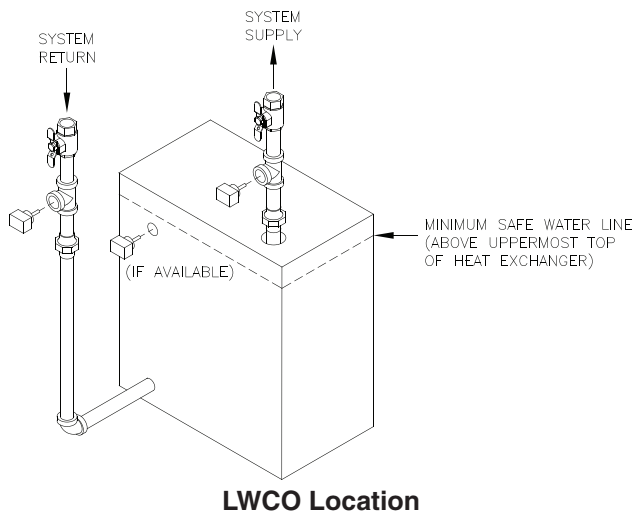

Select the appropriate size tee using the LWCO manufacturer's instructions. Often, the branch connection must have a **minimum** diameter to prevent bridging between the probe and the tee. Also, the run of the tee must have a minimum diameter to prevent the end of the probe from touching or being located too close to the inside wall of the run of the tee.

Ideally, manual shutoff valves should be located above the LWCO and the boiler to allow for servicing. This will allow probe removal for inspection without draining the heating system. Many probe LWCO manufacturers recommend an annual inspection of the probe.

#### How to Wire

LWCO's are available in either 120 VAC or 24 VAC configurations. The 120 VAC configuration must be applied to oil boilers by wiring it in the line voltage service to the boiler (after the service switch, if so equipped).

The presence of water in a properly installed LWCO will cause the normally open contact of the LWCO to close, thus providing continuity of the 120 VAC service to the boiler.

It is recommended to supply power to the probe LWCO with the same line voltage servicing the boiler as shown below.

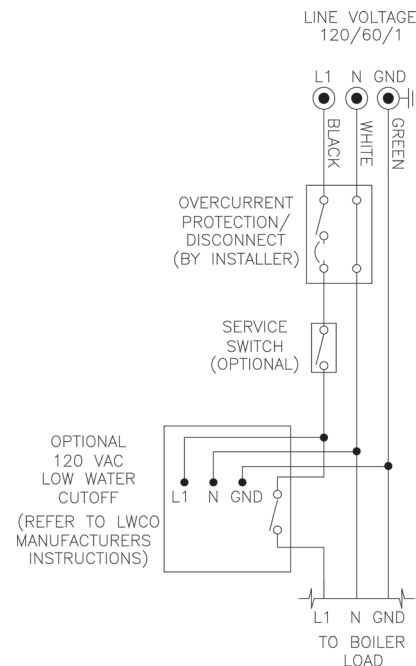

## Appendix - Aftermarket Low Water Cut Off (LWCO)

A 24 VAC LWCO is used primarily for gas fired boilers where a 24 volt control circuit exists within the boiler. However, a 24 VAC LWCO can only be used if the boiler manufacturer has provided piping and wiring connections and instructions to allow for this application.

### How to Test

Shut off fuel supply. Lower water level until water level is BELOW the LWCO. Generate a boiler demand by turning up thermostat. Boiler should not attempt to operate. Increase the water level by filling the system. The boiler should attempt to operate once the water level is above the LWCO.

**New Yorker Boiler Company, Inc.**  
**P.O. Box 3005**  
**Lancaster, Pennsylvania 17603-3005**  
**Attn: Customer Service Department**  
**[www.newyorkerboiler.com](http://www.newyorkerboiler.com)**