



McDonnell & Miller
Installation & Maintenance
Instructions
MM-202(N)

Series PS-801 for Steam Boilers

Series PS-851 **GUARDDOG** for Hot Water Boilers

Probe Type Low Water Cut-Offs



U.S. Pat. No. 6,571,625

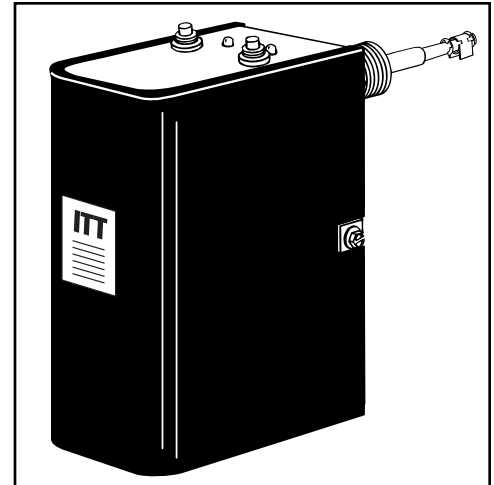

Applications:

Residential and Commercial

PS-851 models can be used as secondary low water cut-offs on steam boilers with pressures up to 15 psi

WARNING

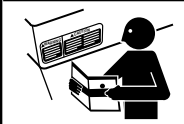

- Before using this product read and understand instructions.
- Save these instructions for future reference.



- All work must be performed by qualified personnel trained in the proper application, installation, and maintenance of plumbing, steam, and electrical equipment and/or systems in accordance with all applicable codes and ordinances.
- To prevent flooding, do not use manual reset models with electric automatic water feeders.
- To prevent electrical shock, turn off the electrical power before making electrical connections.



- This low water cut-off must be installed in series with all other limit and operating controls installed on the boiler. After installation, check for proper operation of all of the limit and operating controls, before leaving the site.



- We recommend that secondary (redundant) Low Water Cut-Off controls be installed on all steam boilers with heat input greater than 400,000 BTU/hour or operating above 15 psi of steam pressure. At least two controls should be connected in series with the burner control circuit to provide safety redundancy protection should the boiler experience a low water condition. Moreover, at each annual outage, the low water cut-offs should be dismantled, inspected, cleaned, and checked for proper calibration and performance.



- When installing jumper wire make sure you are not introducing a second voltage source into the burner circuit and thereby bypassing other safety, limit, and operating controls.
- When using mixed voltages, remove the factory installed jumper wire between terminal (H) and (C), or between (1) and (2) on old Model PS-801-120.

Failure to follow this warning could cause property damage, personal injury or death.

Engineered for life

SPECIFICATIONS

The Series 800 controls provide continuous protection against low water conditions for residential, commercial and industrial applications. Newer models feature increased probe sensitivity to prevent nuisance shut-downs, and a new test feature that diagnoses shorted probe problems at installation. The user-friendly diagnostic LEDs simplify installation and troubleshooting, ensuring proper operation and saving time.

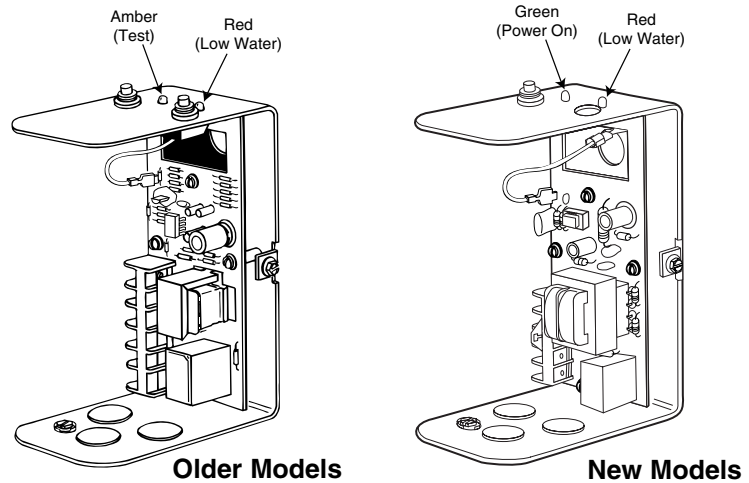

Temperature:

Storage: -40°F to 120°F (-40°C to 49°C)

Ambient: 32°F to 120°F (0°C to 49°C)

Humidity: 85% (non-condensing)

Series PS-801 for Steam Boilers

Preset time delays prevent nuisance burner cycling:

15 second Delay on Make (DOM)

10 second Delay on Break (DOB)

Conductive liquid required

(water/glycol mixtures up to 50% concentration may be used)

Automatic reset after power outage

Maximum Pressure: 15 psi (1kg/cm²)

All models include a provision for adding an alarm or automatic water feeder.

Series PS-851 for Hot Water Boilers

No time delays provided

Conductive liquid required

(water/glycol mixtures up to 50% concentration may be used)

Automatic reset after power outage

Maximum Water Pressure: 160 psi (11.2kg/cm²)

Maximum Water Temperature: 250°F (121°C).

All models include a provision for adding an alarm or automatic water feeder.

Electrical Ratings

Model	Voltage	Motor Switch Rating (Amperes)		Pilot Duty
		Full Load	Locked Rotor	
120 VAC	120 VAC	7.5	43.2	125 VA at 120 or 240 VAC 50 or 60 Hz
	240 VAC	3.75	21.6	

Electrical Enclosure Rating: NEMA 1 General Purpose

Control Voltage: 120 VAC

HZ: 50/60

Probe Sensitivity:

For models with red (low water) and amber (test) lights: 3,000 ohm

For models with red (low water) and green (power) lights: 7,000 ohm

Control Power Consumption:

For models with red (low water) and amber (test) lights: 3 VA

For models with red (low water) and green (power) lights: 3.6 VA

INSTALLATION

TOOLS NEEDED:

One (1) flathead screwdriver, and one (1) pipe wrench.
For Remote Installations a level and power drill will be required.

STEP 1 - Locating and Installing the Probe

a. Based on the following criteria locate a suitable position for the probe (A):

For all Applications:

1. Make sure probe is installed above minimum safe water line as determined by the boiler manufacturer.
2. Make sure that ends and sides of the probe are at least 1/4" (6.4mm) from all internal metal surfaces.
3. Make sure the probe is positioned to shut off the boiler before the water level falls below the lowest visible part of the gauge glass.

For Steam Boilers:

1. Refer to boiler manufacturers instructions to determine suitable tapping for the probe.

For Hot Water Boilers:

1. Refer to boiler manufacturers instructions to determine suitable tapping for the probe.
2. Locate probe in supply piping using a tee fitting.

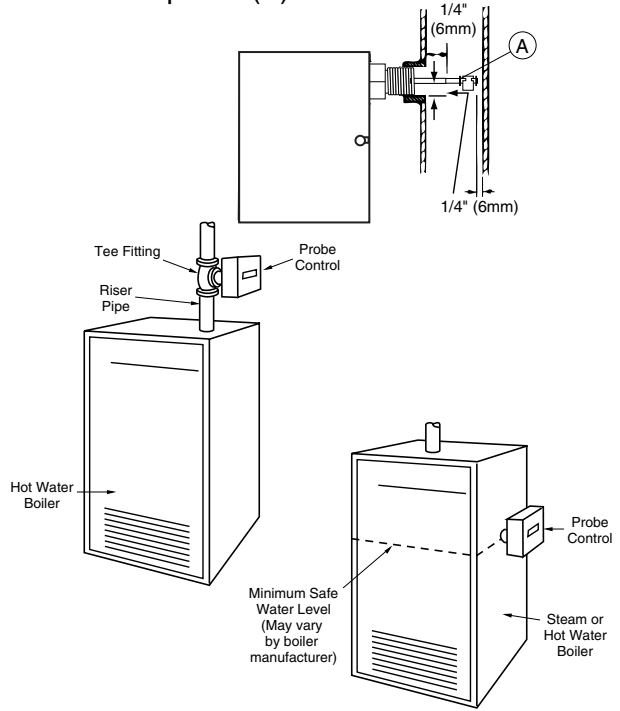

b. Sparingly, apply pipe sealant to the external threads (D) of the probe (A).

IMPORTANT: Do not use Teflon[®] tape. Only use pipe sealant.

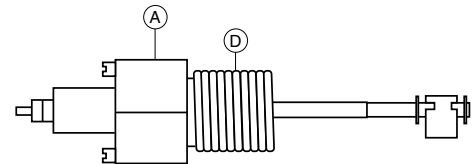

c. Using a wrench, tighten the probe (A) into the tapped connection (E) that was determined in Step 1 of these instructions. Tighten to 47 ft•lb (64 N•m).
NOTE: Be sure to align the probe so that the mounting screws (F) are in a horizontal position.

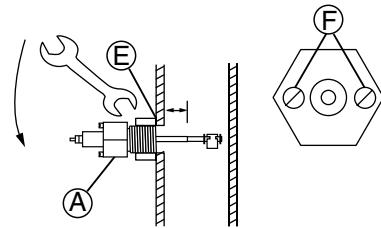

STEP 2 - Installing Control Box

a. Using a flathead screwdriver, loosen the two (2) screws that secure the cover (G) to the control about 1-1/2 turns and remove cover.

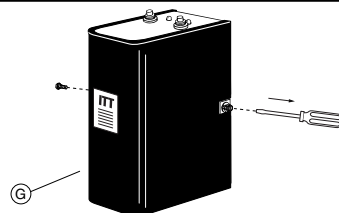

STEP 2 - Installing Control Box (continued)

Direct Mounting

- b. Using a flathead screwdriver, loosen the probe mounting screws (F) 1/8" (3mm) about 1-1/2 turns and slip the control housing (G) over these two screws at a 20° angle.

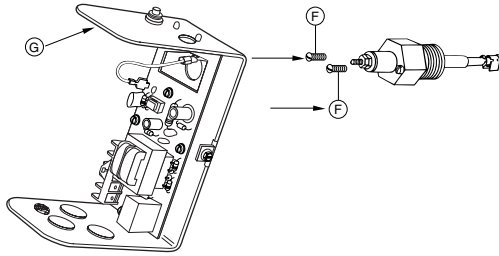

- c. Rotate the control housing (G) 20° counter-clockwise so that the slots in the control base are firmly under the screw heads. Tighten the mounting screws (F) to approximately 2 ft•lb (2.6 N•m).

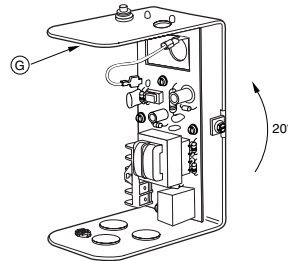

Remote Mounting

- d. Identify a desirable location to mount the control assembly (G) and comply with the following steps:

1. Using a level, draw a horizontal line at the location and mark two positions 1-1/4" (31.75 mm) apart on the horizontal line.
2. Drill a 0.113 dia. hole 1/2" (13 mm) deep in each position on the horizontal line.
3. Insert the two (2) sheet metal screws (provided) into the two holes. Using a flathead screwdriver, tighten the screws so that the base of the screw head is 1/8" from the mounting surface.

* Repeat Steps 2b. and 2c. above.

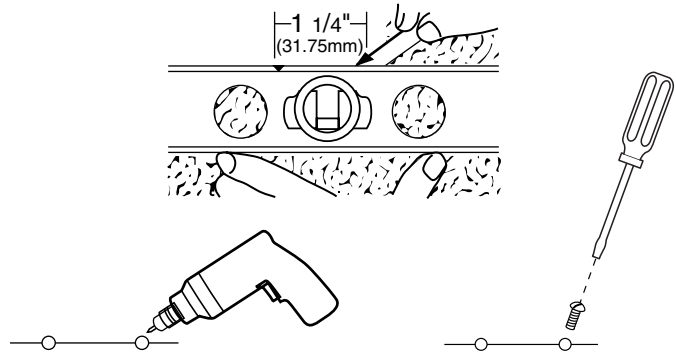

STEP 3 - Probe Wiring

Direct Mounted Probe

- a. Slip the ring terminal lead (J) followed by the lockwasher (K) over the threaded end of the probe (A). Tighten the wing nut (L) onto the probe to approximately 1/2 ft•lb (.65 N•m).

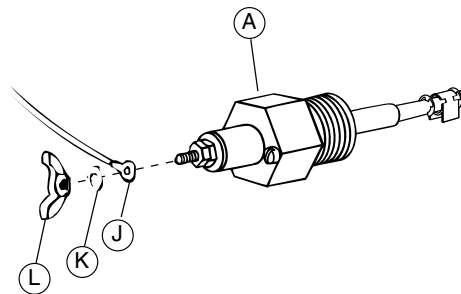

- b. Connect the probe (A) to the wiring circuit by sliding the female quick-connect terminal of the probe wire onto the male spade terminal J3 probe (terminal may be marked J7 on older units).

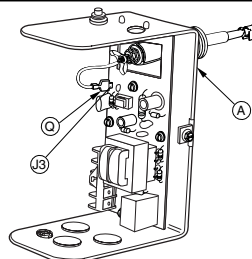

Remote Mounted Probe

c. Connect the probe (A) to the wiring circuit by:

1. Connecting a suitable 16 AWG wire (not provided) to the threaded end (V) of the probe (A).
2. Place the lockwasher (K) and wing nut (L) (provided) over the threaded end of the probe and tighten the wing nut to 1/2 ft•lb (.65 N•m).
3. Using a flathead screwdriver, attach a suitable green 16 AWG wire (not provided) to the green ground screw (X) (provided) at the base of the probe.
4. Route the two wires through a protected wire way to the control unit (G) through the conduit knock-outs in the base of the control.
5. Using the female quick-connect terminal (QQ) provided, connect the wire, from step 1, to the male spade terminal marked "PROBE" (J3). On older units, use the "P" terminal block or (J2) terminal spade connection.
6. Using a flathead screwdriver, connect the green wire, from Step 3, to the green ground screw (W) on the housing of the control.

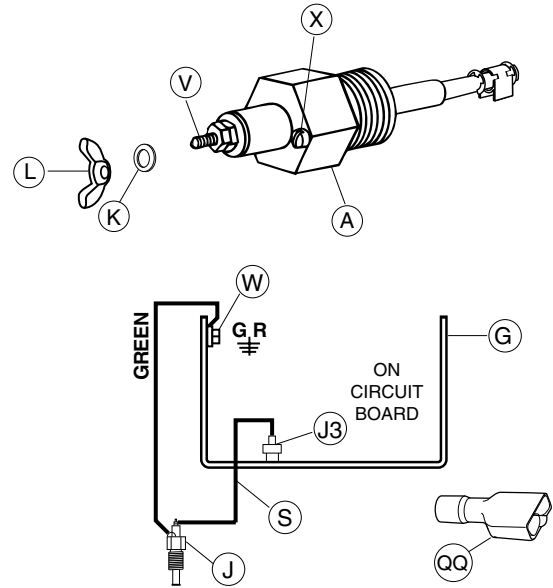

STEP 4 - Control Wiring

WARNING



- To prevent electrical shock, turn off the electrical power before making electrical connections.



- This low water cut-off must be installed in series with all other limit and operating controls installed on the boiler. After installation, check for proper operation of all of the limit and operating controls, before leaving the site.



- All work must be performed by qualified personnel trained in the proper application, installation, and maintenance of plumbing, steam, and electrical equipment and/or systems in accordance with all applicable codes and ordinances.

Failure to follow this warning could cause electrical shock, an explosion and/or fire, which could result in property damage, personal injury or death.

a. Turn off all power to boiler and boiler controls.

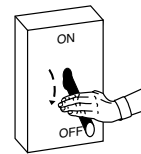

b. Electrical Conduit Connection

- Connect electric conduit using knockouts provided.
- Follow accepted electrical practices when installing fittings and making connections.
- Refer to and follow local codes and standards when selecting the types of electrical fittings and conduit.



CAUTION

Do not use "manual reset" models with electric automatic water feeders.

Failure to follow this caution can cause flooding and property damage.

STEP 4 - Control Wiring (continued)

- c. Based on the Boiler's Control Circuit voltage and the required input voltage of the LWCO, select proper wiring diagram and proceed to that page.

Models with Red (low water) and Amber (test) Lights			Models with Red (low water) and Green (power) Lights		
LWCO Model	Boiler Circuit Voltage	Page	LWCO Model	Boiler Circuit Voltage	Page
PS-801-120	120V	7	PS-801-120	120V	8
PS-801-120	24V	7	PS-801-120	24V	8
PS-851-120	120V	7	PS-851-120	120V	8
PS-851-120	24V	7	PS-851-120	24V	8



IMPORTANT

Boiler manufacturer schematics should always be followed. In the event that the boiler manufacturer's schematic does not exist, or is not available from the boiler manufacturer, refer to the schematics provided in this document.



WARNING



To prevent an electrical fire or equipment damage, electrical wiring must have a rating of 167°F (75°C) if the liquid's temperature exceeds 180°F (82°C). Failure to follow this warning could cause property damage, personal injury or death.

Wiring Diagram Legends

1. Bold lines indicate action to be taken in Step shown.
2. Dotted black lines indicate internal wiring.

- d. For all wire connections to the terminal block (M).

1. Strip about 1/3" (8.5 mm) of insulation from the wire.
2. Loosen the terminal screw (N) but DO NOT REMOVE. Move the wire clamping plate (P) back until the plate touches the back side of the screw head.
3. Insert the stripped end of the wire under the wire clamping plate (P) and securely tighten the terminal screw (N).

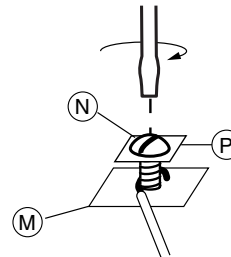

PS-801/851 with 120 Volt Burner Circuit with Red (Low Water) and Amber (Test) Lights

- Hot wire (A) of 120 volt circuit to terminal (1).
- Connect Neutral wire (B) of 120 volt circuit to terminal (2).
- Connect wire (C) from beginning of Burner circuit (thermostat, gas valve, limits, etc.) to terminal (5).
- Connect wire (D) from end of Burner circuit to terminal (2).
- Install wire (E) connecting (1) and (3).

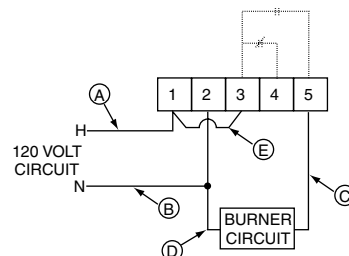

PS-801/851 with 24 Volt Burner Circuit with Red (Low Water) and Amber (Test) Lights

- Connect wire (A) of 120 volt circuit to terminal (1) and terminal (L1) of transformer.
- Connect wire (B) of 120 volt circuit to terminal (2) and terminal (L2) of transformer.
- Connect wire (C) to terminal (3) and terminal (T1) of transformer.
- Connect wire (D) from beginning of Burner circuit (thermostat, gas valve, limits, etc.) to terminal (5).
- Connect wire (E) from end of Burner circuit to terminal (T2) of transformer.

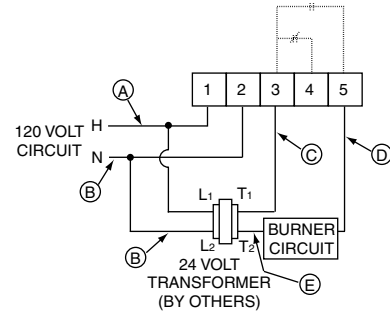

PS-801/851 with 120 Volt Burner Circuit with Red (Low Water) and Green (Power) Lights

- Connect Hot wire (A) of 120 volt circuit to terminal (H).
- Connect Neutral wire (B) of 120 volt circuit to terminal (N).
- Connect wire (C) from beginning of Burner circuit (thermostat, gas valve, limits, etc.) to terminal (B).
- Connect wire (D) from end of Burner circuit to terminal (N).
- Connect jumper wire (E) to terminals (H) and (C).

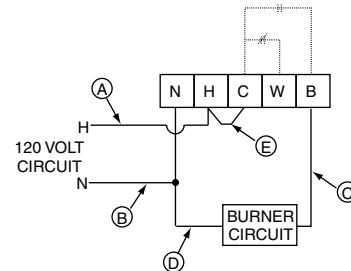

PS-801/851 with 24 Volt Burner Circuit with Red (Low Water) and Green (Power) Lights

- Connect hot wire (A) of 120 volt circuit to terminal (H) and transformer terminal (L1).
- Connect neutral wire 'B' of 120 volt circuit to terminal (N) and transformer terminal (L2).
- Connect wire (C) from beginning of Burner circuit (thermostat, gas valve, limits, etc.) to terminal (B).
- Connect wire (D) from end of Burner circuit to transformer terminal (T2).
- Connect wire (E) from transformer terminal (T1) to terminal (C).

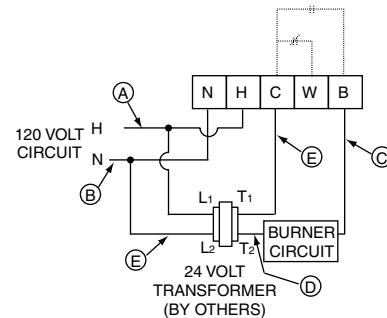

- e. Place the cover on the control housing, and, using a flathead screwdriver, tighten the two (2) screws into the control housing and cover (G) to approximately 2 ft•lb (2.6 N•m).

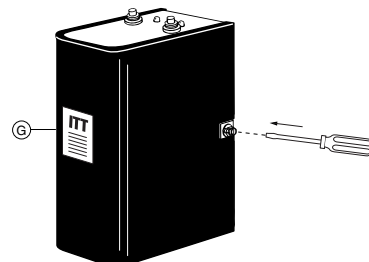

INSTALLATION COMPLETE

STEP 5 - Testing

	Page
All Models with Red (Low Water) and Amber (Test) Lights	8
Series PS-801 and PS-801-M with Red (Low Water) and Green (Power) Lights	9
Series PS-851 and PS-851-M with Red (Low Water) and Green (Power) Lights	10

All Models with Red (Low Water) and Amber (Test) Lights

- a. **Before filling the system, turn on the electric power to the boiler. Set the room thermostat to "heat".**

For Series PS-801 the burner will come on briefly (10 second or less) and then shut off which verifies proper operation. The burner **will not** operate without water in the system. The low water cut-off's red LED should be illuminated.

For Series PS-851 the burner will come on briefly and then shut off, verifying proper operation. The burner **will not** operate without water in the system. The low water cut-off's red LED should be illuminated.

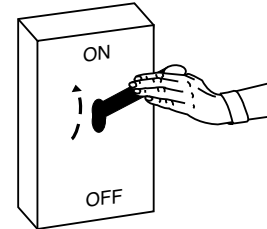

- b. Fill the system with water.

For Series PS-801 the low water cut-off's red LED should shut off in about 15 seconds, after the water contacts the probe.

For Series PS-851 the low water cut-off's red LED should shut off after the water contacts the probe.

- c. Hold the test switch (AA) down while noting the amber LED (BB) on top of the control housing (G).
- If the amber LED (BB) glows dimly**, the water level is above the probe.
 - If the amber LED (BB) is off**, the water level may be below the probe or the water is too pure and may require the addition of boiler water treatment.
 - If the amber LED (BB) glows brightly**, it could indicate a grounded (non-operable) probe. If this is the case, proceed to "Troubleshooting".

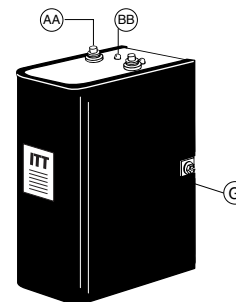

- d. Test for correct burner circuit wiring.
- Hold down the test switch (AA) while the burner is running for more than:
 - 12 seconds for PS-801
 - 2 seconds for PS-851
 - If the burner shuts off while the test switch is depressed, the burner circuit is wired correctly.

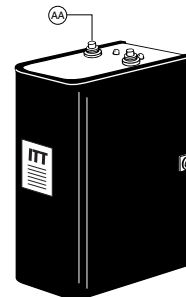

- e. **For the automatic reset models** - Release the test switch (AA) and the burner should resume firing provided that the boiler water is in contact with the probe.

For the manual reset models - The burner will not return to normal operation until the reset switch (CC) is set.

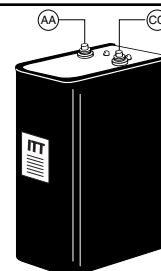

- f. Check for proper operation of all of the limit and operating controls, before leaving the site.

- g. If you believe the probe to be grounded, follow the following steps for a control (G) with a test switch (AA):

1. Make sure that the liquid level is below the probe.
2. Depress the test switch (AA). If the amber LED (BB) turns "ON" the probe may be grounded. If so, replace the grounded probe.

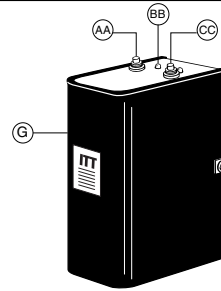

For Series PS-801 & PS-801-M with Red (Low Water) and Green (Power) Lights

Start-Up

- a. **Before filling the system**, turn on the electric power to the boiler. Set the thermostat to "heat".

For all Series PS-801

1. Upon initial power up, the Green and Red lights will flash simultaneously 4 times.
2. The Green light will turn "ON".
3. The Red light will continue to flash for 10-seconds Delay on Break (DOB) and then turn "ON".
4. If a water feeder has been installed and does not have a time delay, it will turn "ON".
5. The burner will never turn "ON" during power up, if water is off the probe.

- b. **Now fill the boiler with water.**

For Series PS-801 (auto reset units only)

1. When water touches the probe, the Red light will start flashing for 15-seconds Delay on Make (DOM) and then turn "OFF".
2. The burner will turn "ON" as long as there is water on the probe.
3. If a water feeder has been installed it will turn "OFF".

For Series PS-801-M (manual reset units only)

(When water returns to the probe, nothing will happen until the manual reset button is depressed.)

1. After depressing manual reset button, the Green and Red lights will flash simultaneously 4 times.
2. Then the Green light will turn "ON".
3. The Red light will continue to flash for 15-seconds (DOM) and then turn "OFF".
4. The burner will turn "ON" as long as there is water on the probe.

(Warning: To prevent flooding, never use a "water feeder" with a manual reset low water cut-off.)

Manually Testing Control

- c. **Slowly drain the boiler of water.**

For all Series PS-801 (both auto and manual reset units)

1. When water drops off the probe, the Red light will start flashing for 10-seconds (DOB) and then turn "ON".
2. The burner will turn "OFF".
3. If a water feeder has been installed and does not have a time delay, it should turn "ON".

(Warning: To prevent flooding, never use a "water feeder" with a manual reset low water cut-off.)

For Series PS-801 & PS-801-M with Red (Low Water) and Green (Power) Lights (continued)

Testing Control Using "Test Button"

d. Depressing test button with "water on probe" for Series PS-801 (auto reset units only):

(Must depress and hold the test button to activate test cycle.)

1. When test cycle is activated the Green and Red lights will flash.
2. After 10-seconds (DOB) the Red light will turn "ON".
3. Burner will turn "OFF".
4. The Green light will continue flashing as long as test button is depressed.
5. If a water feeder has been installed and does not have a time delay, it will turn "ON".

(Release test button, if water is still on probe)

6. The Green light will stop flashing and turn "ON".
7. The Red light will start flashing for 15 seconds (DOB) and then turn "OFF".
8. Burner will turn "ON" as long as there is water on the probe.
9. If a water feeder has been installed it will turn "OFF".

e. Depressing test button with "water on probe" for Series PS-801-M (manual reset units only):

(Must depress and hold test button to activate test cycle.)

1. When test cycle is activated the Green and Red lights will flash.
2. After 10 seconds (DOB) the Red light will turn "ON".
3. Burner will turn "OFF".
4. The Green light will continue flashing as long as test button is depressed.
5. After depressing manual reset button, the Green and Red lights will flash simultaneously 4 times.
6. Then the Green light will turn "ON" and the Red light will flash for 15 seconds (DOB) and then turn "OFF".
7. The burner will turn "ON" as long as there is water on the probe.

(Warning: To prevent flooding, never use a "water feeder" with a manual reset low water cut-off.)

f. Depressing test button with "water off probe" (both auto and manual reset units):

Since control is in "low water" the Green light will flash and the Red light will remain "ON". The burner will remain "OFF".

For Series PS-851 & PS-851-M with Red (Low Water) and Green (Power) Lights Start-Up

a. Before filling the system, turn on the electric power to the boiler. Set the thermostat to "heat".

For all Series PS-851

1. Upon initial power up, the Green and Red lights will flash simultaneously 4 times.
2. The Green and Red lights will turn "ON".
3. The burner will never turn "ON" during power up, if water is off the probe.

b. Now fill the boiler with water.

For Series PS-851 (auto reset units only)

1. When water touches the probe, the Green light will remain "ON".
2. The Red light will turn "OFF" and the burner will turn "ON" as long as there is water on the probe.

For Series PS-851-M (manual reset units only)

(When water returns to the probe, nothing will happen until the manual reset button is depressed.)

1. After depressing manual reset button, the Green and Red lights will flash simultaneously 4 times.
2. Then the Green light will turn "ON" and the Red light will turn "OFF".
4. The burner will turn "ON" as long as there is water on the probe.

(Warning: To prevent flooding, never use a "water feeder" with a manual reset low water cut-off.)

For Series PS-851 & PS-851-M with Red (Low Water) and Green (Power) Lights (continued)

Manually Testing Control

c. Slowly drain the boiler of water.

For all Series PS-851 (both auto and manual reset units)

1. When water drops off the probe, the Green light will remain "ON".
2. The Red light will turn "ON" and the burner will turn "OFF", if water is off the probe.

Testing Control Using "Test Button"

d. Depressing test button with "water on probe" (auto reset units only):

(Must depress and hold the test button to activate test cycle.)

1. When test cycle is activated the Green light will flash.
2. The Red light will turn "ON".
3. Burner will turn "OFF".
4. The Green light will continue flashing as long as test button is depressed.

(Release test button, if water is still on probe)

5. The Green light will stop flashing and turn "ON".
6. The Red light will turn "OFF".
7. Burner will turn "ON" as long as there is water on the probe.

e. Depressing test button with "water on probe" (manual reset units only):

(Must depress and hold test button to activate test cycle.)

1. When test cycle is activated the Green light will flash.
2. The Red light will turn "ON".
3. Burner will turn "OFF".
4. The Green light will continue flashing as long as test button is depressed.

(Release test button. You must depress the manual reset button to unlock low water cut-off.)

5. After depressing manual reset button, the Green and Red lights will flash simultaneously 4 times.
6. Then the Green light will turn "ON" and the Red light will turn "OFF".
7. The burner will turn "ON" as long as there is water on the probe.

(Warning: To prevent flooding, never use a "water feeder" with a manual reset low water cut-off.)

f. Depressing test button with "water off probe" (both auto and manual reset units):

Since control is in "low water" the Green light will flash and the Red light will remain "ON". The burner will remain "OFF".

Troubleshooting

If control fails to operate as required, perform the following diagnostic checks:

1. Check to be sure that the water level in the boiler is at or above the level of the probe.
2. Re-check all wiring to ensure proper connections as specified in boiler manufacturer's wiring diagrams or these instructions.
3. Check to ensure that Teflon® tape has not been used on the threaded connection of the electrode to the boiler.
4. Re-check the electrical ground connection for the remote sensor and control unit.
5. Check the quality of the boiler water to ensure adequate conductance.

CAUTION

Replace Probe if:

- Teflon® insulator is cracked or worn.
- Probe is loose.

Failure to follow this caution could cause property damage, personal injury or death.

MAINTENANCE

SCHEDULE:

- Test the low water cut-off annually or more frequently.
- Remove and inspect the self-cleaning probe every 5 years.
- Replace probe every 10 years.
- Replace the lo water cut-off control box every 15 years.

NOTE

Clean probe by wiping with non-abrasive cloth and rinsing with clean water. DO NOT use sharp instruments to remove any accumulations of rust or scale.