



V-SERIES™ APPLICATION GUIDE

ARCHITECTS • ENGINEERS • BUILDERS

TABLE OF CONTENTS

1. PURPOSE OF THIS MANUAL

2. MAGIC-PAK: DESIGNED AND BUILT FOR EVERY STAGE OF DEVELOPMENT

- 2.1 TOTALLY PACKAGED HVAC SYSTEM PROVIDES INDIVIDUAL COMFORT CONTROL
- 2.2 SLIDE-OUT COOLING CHASSIS
- 2.3 HERMETICALLY SEALED REFRIGERATION SYSTEM
- 2.4 INTERCHANGEABLE WITH EARLIER MODELS
- 2.5 GAS AND ELECTRIC ALTERNATIVES

3. UNIT LOCATION

- 3.1 GENERAL CONSIDERATIONS
- 3.2 SOUND CONSIDERATIONS
- 3.3 ACCESSIBILITY
- 3.4 VENT LOCATION FOR GAS MODELS

4. WALL SLEEVES

- 4.1 INSTALLATION
- 4.2 RECESSED SLEEVES
- 4.3 WEATHER-PROOFING WALL SLEEVES

5. TYPES OF WALL CONSTRUCTION

- 5.1 SUPPORT
- 5.2 WOOD-FRAME WALLS
- 5.3 CEMENT BLOCK WALLS
- 5.4 POURED CONCRETE WALLS
- 5.5 METAL STUDS

6. NOISE TRANSMISSION

- 6.1 VIBRATION TRANSMISSION
- 6.2 RADIATED SOUND AND RESONANT SURFACES OR OBJECTS
- 6.3 CLEARANCES
- 6.4 DETERMINATION OF SOUND RATING VALUES
- 6.5 AIR NOISE
 - 6.5.1. SUPPLY-AIR DUCT SYSTEM
 - 6.5.2. RETURN-AIR DUCT SYSTEM

7. INFILTRATION

- 7.1 WATER INFILTRATION
- 7.2 AIR INFILTRATION
- 7.3 INTRODUCTION OF VENTILATION AIR
- 7.4 SEALING RETURN-AIR DUCTS
- 7.5 SEALING WALL SLEEVE

8. OUTSIDE DECORATIVE FACADES, GRILLES OR LOUVERS

- 8.1 GRILLE AND LOUVER FURNISHED ON MAGIC-PAK
- 8.2 OUTSIDE APPEARANCE VARIATIONS
- 8.3 CONSIDERATIONS FOR CUSTOM LOUVERS
- 8.4 CONTROL OF SOUND WITH LOUVERED GRILLES

9. CONDENSATE

- 9.1 CONDENSATE DRAIN
- 9.2 HIGH EFFICIENCY UNITS

10. ELECTRICAL SERVICE WIRING

11. AIR FILTER

12. SPECIAL CONSIDERATION FOR GAS UNITS

NOTES

1. PURPOSE OF THIS MANUAL

This manual provides assistance to architects and design engineers who are considering the use of Magic-Pak heating and cooling equipment in multi-dwelling buildings.

This document conveys some of the experience gained over many decades, and includes some of the most successful and economical installation practices for Magic-Pak units.

Building structure heat loss and heat gain, duct sizing, gas supply mains and riser sizing, and electrical-supply wiring should be determined for the building by a qualified Professional Engineer familiar with the applicable local building code requirements for the type of occupancy.

2. MAGIC-PAK: DESIGNED AND BUILT FOR DESIGNERS AND BUILDERS

2.1 TOTALLY PACKAGED HVAC SYSTEM PROVIDES INDIVIDUAL COMFORT CONTROL

The Magic-Pak concept provides all the practical benefits of a split system, plus a heating system, without the expense and complications of split-system units. Magic-Pak provides a ducted, single-package, combination heating-and-cooling unit for each individual suite that is reliable, easy to install and inexpensive to maintain. Just as important, it allows individual metering and control for each unit.

Occupants can have heating or air conditioning any time of the year according to the outdoor temperature. A cold day in June, heating; a hot day in January, cooling. This is flexibility you may not get from some central systems.

2.2 SLIDE-OUT COOLING CHASSIS

The slide-out cooling chassis is unique to Magic-Pak units and is a chief contributor to the ever-increasing popularity of the product. If service is required, any cooling chassis may be replaced with another in minutes. In fact, building maintenance personnel can easily perform this function without the refrigeration training or trade credentials often required to work on refrigeration systems.

2.3 HERMETICALLY SEALED REFRIGERATION SYSTEM

The hermetically sealed refrigeration system is another feature of the Magic-Pak's slide out refrigeration chassis. The system is completely factory-built, checked for leaks with sensitive electronic equipment, and thoroughly performance tested before placement in any unit. This comprehensive testing eliminates the need for highly trained personnel at the time of installation or start up.

2.4 INTERCHANGEABLE WITH EARLIER MODELS

Another advantage of the slide-out chassis is the one that eliminates concerns of obsolescence. Replacement chassis are only available for units going back to 3rd version units. The chassis built today include modern technology in heat transfer surface and compressor design for higher efficiencies, but the chassis will still fit the older Magic-Pak models. For more information, contact application specialist.

Dedication to this interchangeability with earlier models is basic to the Magic-Pak concept of today and insures that these units will never become "orphans" in the future.

For over 50 years, the Magic-Pak concept of providing heating and cooling in high-rise condominiums and apartment buildings has proven increasingly popular among building designers and mechanical contractors.

Over these years with literally hundreds of thousands of units installed throughout the United States and Canada, we have compiled comprehensive practical experience for varying types of building construction and operating conditions.

2.5 GAS AND ELECTRIC ALTERNATIVES

Magic-Pak offers a variety of heat sources to best suit the geographic area or local energy costs. All are ducted, through-the-wall units which have no need for chimney/vent pipe.

HWC -Gas Heating, Electric Cooling:

Depending on energy cost in your area, gas heating could maximize applications where gas is available. Magic-Pak is classified as a direct vent application which uses only outside air for combustion. This allows the built-in power vent to eliminate the need for a chimney.

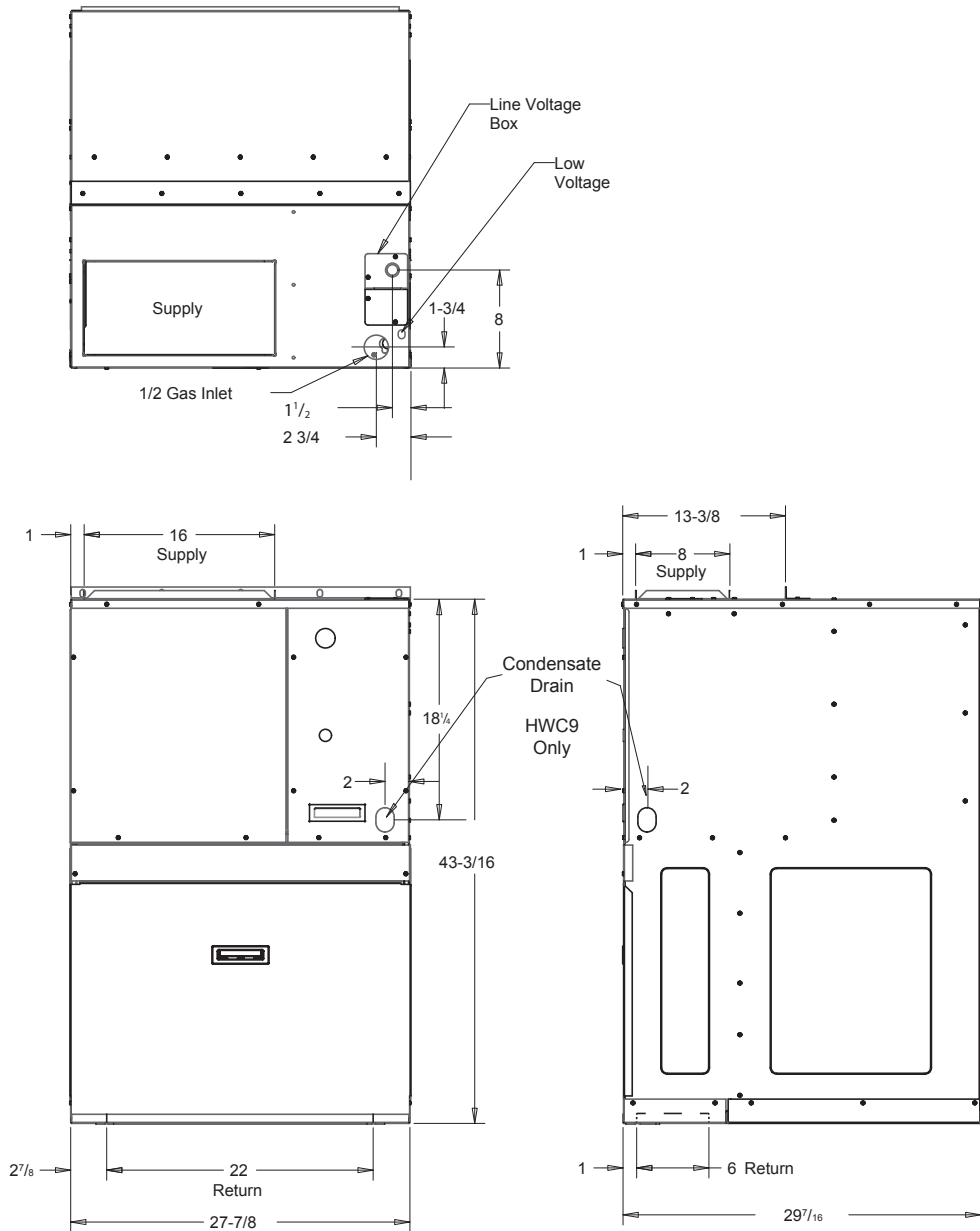

Fig 1. HWC V-Series Model

EWC - Electric Heating

Electric heating and cooling is an alternative solution when gas is not available, or in milder geographies.

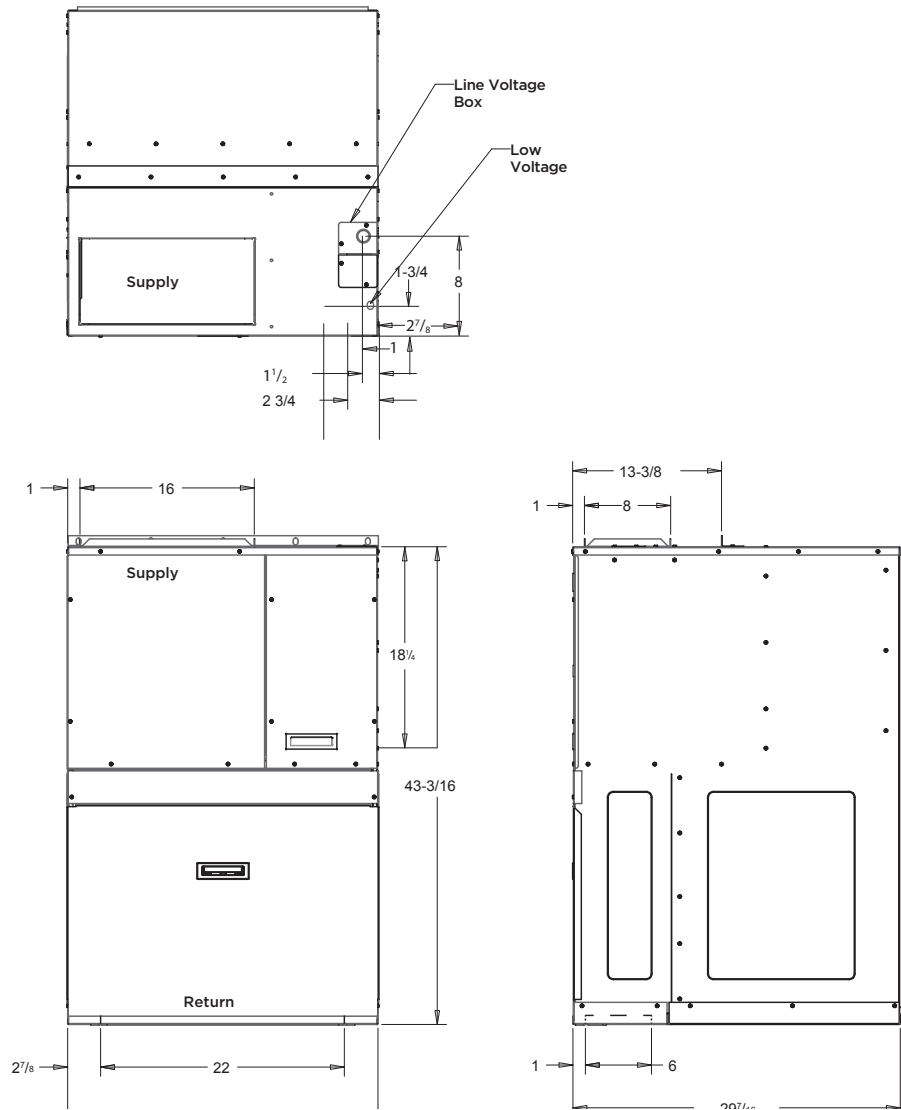
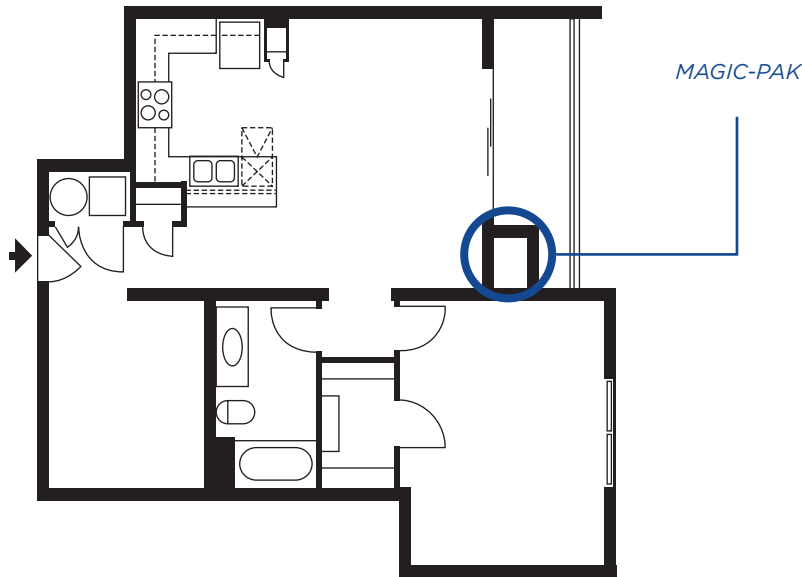

Fig 2. EWC V-Series Model

3. UNIT LOCATION



Magic-Pak units should be installed in an exterior building wall that is clear of obstructions which might impede the free intake and discharge of condenser air.

Figure 3. Condominium with Magic-Pak on exterior wall

3.1 GENERAL CONSIDERATIONS

A building wall should be no closer to an opposite building wall than two feet for every floor or Magic-Pak unit in a vertical array facing the wall. For example, a one-story building with a Magic-Pak unit should be a minimum of 2 ft. from the wall facing the unit, and if the facing wall also has a Magic-Pak unit, the two walls should be at least 4 ft. apart.

A six-story building with six Magic-Pak units in a vertical array should be at least 12 ft. from the opposite building wall, and if that building wall also contains Magic-Pak units, the buildings should be at least 24 ft. apart.

Buildings taller than six stories need not exceed the separation needed for six-story buildings. If three or more adjacent walls form an air shaft with Magic-Pak units facing each other in each wall, the separation between opposite walls should be increased by 20%.

These “rules-of-thumb” dimensions are intended to minimize possibilities for recirculation of condenser air, or interaction between units. However, these numbers are not exact for every application, and other considerations might suggest that the designer consult the application specialist about desired alternatives. In colder climates, the location of a unit should be considered due to possible frost back-up.

Buildings that are designed with the utility closet next to each other, or stacked, need to have a minimum horizontal clearance of 12” between units and a vertical clearance of 60” between units (see Fig. 4).

3.2 SOUND CONSIDERATIONS



Fig 4: Building Clearance Needed

It should be mentioned that any time a hard surface or wall faces a unit, the sound emanating from that unit can be reflected by the opposite wall. If the two walls are not parallel, the sound may be somewhat dispersed, but in general it is preferable to locate Magic-Pak units in a wall with as much clear distance to the nearest wall or reflecting surface as is practical.

Units located in walls forming an air shaft or confined courtyard are not as desirable (from a sound standpoint) as units located in the outer perimeter walls of a building.

Similarly, if the unit is to be installed in a wall at right angles to a wall containing a window, at least 6 ft. of separation between the closest point of glass to the unit should be maintained in order to minimize sound transmission through the window.

If, however, such a location is unavoidable contact the application specialist. For suggestions on how others have succeeded in overcoming the challenges.

3.3 ACCESSIBILITY

An important consideration when selecting a suitable location is accessibility for chassis removal. A 30 in. wide minimum clear opening is needed in front of the unit in order to remove the chassis. A 36 in. wide door or access covering to the enclosure is preferred as a minimum to allow for some tolerance in locating the access door frame exactly centered on the unit (Fig 5).

If the unit is located in the end of a clothes closet, and it is accepted that the clothes must be removed first to remove the chassis, be sure that the closet door is large

enough to get the chassis out of the closet.

Also, if the Magic-Pak is installed through the side of a closet, be sure the closet is wide enough to permit sliding the chassis all the way out before running into the opposite closet wall.

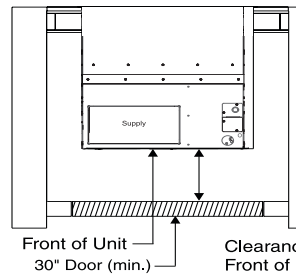

Fig 5: clearance needed for Chassis.

(Note: There are special dollies available through wholesalers that can lean the platform from vertical to horizontal with an elevating-adjustment feature and four wheel support. These are very useful in close quarters to provide a platform to slide the chassis onto during removal and subsequent replacement of a chassis.)

Units in a relatively inaccessible location for easy chassis removal should be avoided if at all possible; if for no other reason than to keep the air filter accessible for easy and timely cleaning by the occupants or by maintenance personnel.

3.4 VENT LOCATION FOR GAS MODELS

Vent location of gas-fired Magic-Pak models must comply with the latest edition of the National Fuel Gas Code (NFPA 54/ANSI Z223.1), and local codes.

The design is certified for indoor installation only. The interior portions of the unit may be surrounded by a closet with minimum clearances to combustible material held to 0" sides, 2" top, and 1" front and plenum. Adequate clearance must be provided to install gas line union and manual shutoff valve as well as providing accessibility for field wiring. Do not install directly on carpeting, tile, or other combustible material other than wood flooring. The grille side of the unit may be flush with, or extend beyond, the face of exterior wall, but should not be recessed more than 2" from the face of the building and should not be obstructed with trees, landscape materials, or building structure (see Fig. 4). There is no minimum clearance required on locating the unit to an interior corner of a building.

4.1 INSTALLATION

The sleeve may extend farther than 1 in. beyond the finished wall, but reaching the perimeter of the opening from inside for sealing becomes increasingly difficult (Figs. 9 & 10)

In many high-rise construction applications, contractors insert the wall sleeves from the outside while the wall is being constructed (Fig. 11, 12, 13). The two-sided support angles furnished with the wall-sleeve kit should then be attached to the wall sleeve sides at a location that will exceed the thickness of the outside finish wall by the recommended 3/8 in. to 1 in. dimension. Support angles should not be considered flashing.

For example, if the supporting wall is concrete block with a brick facing, there is usually a space between the block and the brick. This space dimension must be added to the width of the brick (plus 3/8 in. to 1 in.) so that when the sleeve is inserted into the block-wall opening, up to the angles, and fastened to the block wall before the brick is installed, the sleeve will protrude beyond the finished brick by 3/8 in. to 1 in., as needed for caulk sealing.

The wall sleeve must be fastened to the supporting wall and not to the finished wall.



Figure 9: Wall sleeve installed from outside angle 1

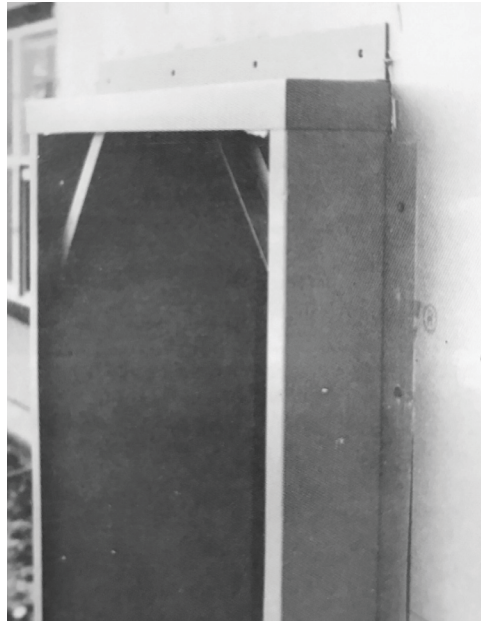

Figure 10: Wall sleeve from outside angle 2



Figure 11 - Wall sleeve installed from outside angle 3

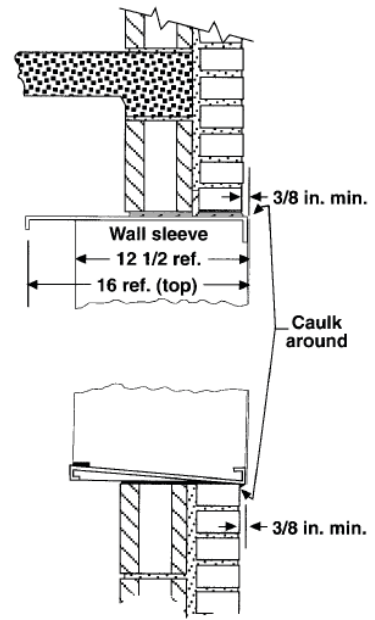

Figure 12 - Caulk around sleeve

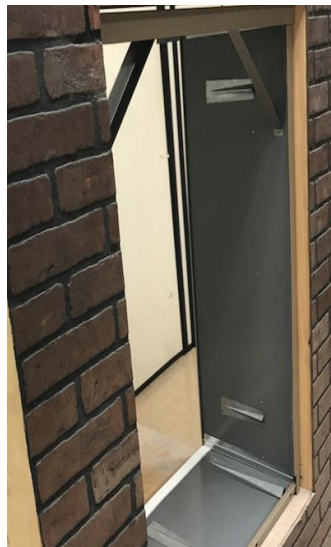

Figure 13 - Fasteners shot through wall sleeve sides into back wall

Some builders will attach through the side support angles to the support wall whether inserting the sleeve from the outside or inside. Others will use the side angles simply as a locating “stop” to achieve the appropriate dimension while shooting fasteners through the sides of the wall sleeve into the supporting wall (See Fig. 13).

The most popular method of installing the wall sleeve is from the inside of the building with the weather seal applied from the outside as the finish wall is applied (See Fig. 19).

4.2 RECESSED SLEEVES

In some applications, where building walls are very thick (over 16 in.) or architectural design dictates, units can be recessed. One should avoid recessing the wall sleeve if the wall opening is required to be the same as the wall-sleeve opening. However, if the wall opening can be larger in vertical dimension than the wall sleeve, so that the bottom can rest on a sill that is at least 2 in. higher than the bottom of the wall opening, some recessing is permitted (Figs. 13 and 14).

This sill should be recessed further than the sleeve by $\frac{3}{8}$ in. to 1 in. to permit weather-seal caulking along the bottom edge without plugging the drain holes in the sleeve. See Fig. 15.

The top of the wall opening should be above the top of the wall sleeve by a dimension equal to or greater than the amount of the recess to avoid restriction of the condenser discharge air.



Figure 14: Recessed wall sleeve with enlarged and tapered-edge opening.

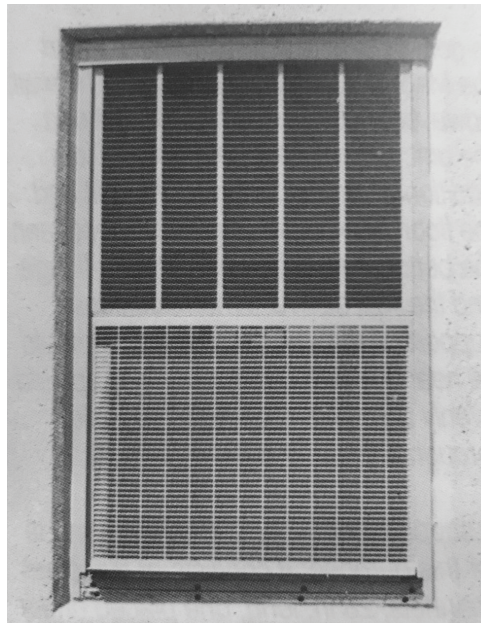

Figure 15: Recessed wall sleeve with enlarged and tapered-edge opening.



Figure 16 - For additional protection against air infiltration during periods of very high winds, fill the clearance space between unit and wall sleeve all around with sealant.



Figure 17 - Caulk seal outside joints of wall sleeve before inserting into wall opening (Underside view of wall sleeve bottom).



Figure 18 - Caulk seal outside joints of wall sleeve before inserting into wall opening.

4.3 WEATHER-PROOFING WALL SLEEVES

Wall sleeves are packaged one to a carton and are shipped flat. They snap together easily at the job site and are held square (until ready to receive a Magic-Pak) by two braces fastened inside the top corners. Instructions for caulk sealing the slip joints and spot-welded joints are included.

This sealing must be done after the wall sleeve is assembled, but before the Magic-Pak unit is installed in the sleeve. Caulk sealing of the bottom is best accomplished right after the wall sleeve is assembled but before it is placed in the wall opening (Fig. 17). Remaining final sealing can be done just after the sleeve is secured into the wall opening, if desired, to avoid breaking the seal during handling (Fig. 19).

Further sealing against air infiltration must be done after the Magic-Pak unit is installed in the wall sleeve and utility connections are completed. For additional protection, the space between the unit and the wall sleeve should be sealed on all sides with a bead of sealant.

5. TYPES OF WALL CONSTRUCTION

5.1 SUPPORT

In general, a wall sleeve will support a Magic-Pak units on any wall. The wall, however, must be adequate to support the unit. Otherwise, one must provide additional support between the unit and the floor. The center of gravity is between the bottom return-air opening rear flange and the wall sleeve. When additional support for the unit is desirable, it should be near this center of gravity and applied evenly across the bottom of the unit through adjustable legs to the floor.

A supplementary support can be made for this purpose. It consists of two steel channels, 28 in. long, one placed under the unit and one on the floor. They are separated by 3/4 in. pipe and “all-thread” rod, with nuts and washers, to provide the adjustment pressure (Fig. 21). Vibration isolation blocks are also required to minimize transmission of vibration into the floor (Figs. 20 and 21).

Even though the wall may be adequate to support the unit, experience has shown the desirability of supplementary support as described above, reducing the possibility of vibration transmitted into the wall and to other parts of the structure.

Two 1 in. diameter holes are located near the front of the Magic-Pak on either side of the return-air opening. These holes are intended to allow a condensate drain tube to exit the return-air duct cavity whenever a closed return duct and flexible collar are used. These should not be used to support the unit. The sheet metal cabinet in this area is not heavy enough to act as a support without distorting and interfering with proper retention of the filter access cover (Fig. 22).



Figure 19: Vibration Isolation Pad

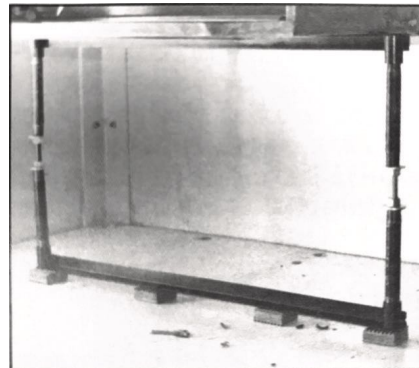

Figure 20: Photo of support under unit with vibration pad in place



Figure 21: Condensate-tube installed



Figure 22: Condensate-tube installed

5.2 WOOD-FRAME WALLS

The framed opening should consist of double 2x4 or 2x6 on both sides and across the bottom of the opening, with at least one vertical support under the center of the opening (Fig. 23).

If the wall sleeve is inserted from the inside, the unit can be amply supported by lag screws inserted into the double 2x4 through the side mounting angles on both sides of the wall sleeve. However, the angle must seat against solid wood all the way up and down, not against any dry wall or soft wall board which might disintegrate under conditions of prolonged pressure or vibration.

If the wall sleeve is inserted from outside, the same concerns apply. The mounting angles should seat against solid wood studs or plywood sheathing, not against soft insulating sheathing.

Most wood-frame stud walls are strong enough to support the Magic-Pak unit, and in many cases are more effective than concrete walls in reducing vibration frequencies carried from one floor to another. However, the remainder of the wall construction and its rigidity is the controlling factor for vibration control.

A light weight wall with little or no insulation, thin interior dry wall, and exterior sheathing can be excited by vibrating machinery and will transmit the vibration more easily into other areas. As a precaution against this possibility, it is recommended that vibration pads be placed in the bottom outside edge of the wall sleeve before the Magic-Pak is inserted into the wall sleeve.

Further, a supplementary support should be used, consisting of transverse support channels located near the center of gravity and isolated with four vibration pads between the upper channel and the bottom of the Magic-Pak, in addition to four vibration pads located between the lower channel and the floor (Fig. 21).

Lifting the weight of the unit is achieved by turning the nuts on the threaded legs of the supplementary support sufficiently to transfer the unit weight to the vibration pads on the floor, but not so much that the unit is lifted completely off of the weather seal gasket located between the wall sleeve bottom and the unit bottom.

Some pressure should remain on the gasket to provide a weather seal.

Also, the wall-sleeve-to-unit vertical gaskets on the outdoor side should still seat against the unit all the way from top to bottom and not be opened up near the bottom by too much lift pressure from the jack screws.

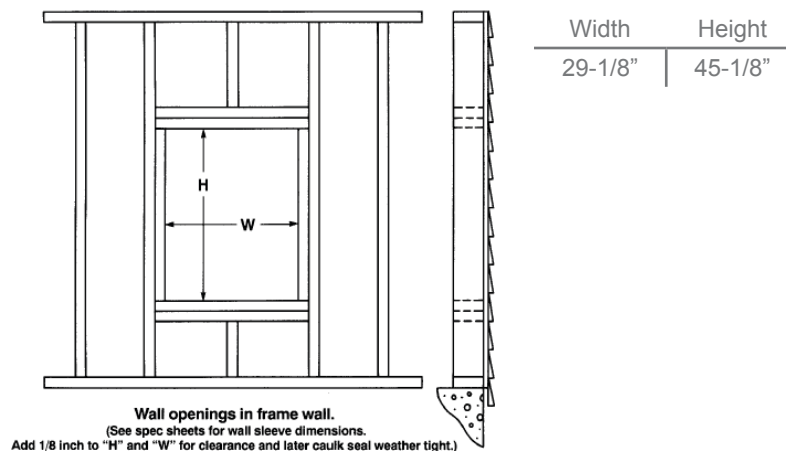

Figure 23 : Line drawing of frame wall with opening braced for wall sleeve attachment

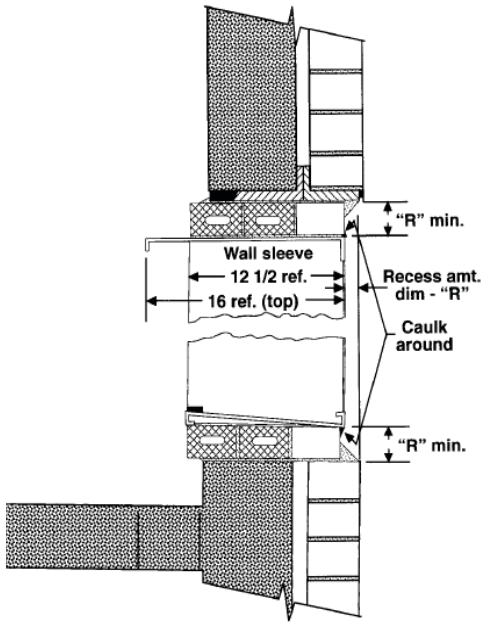

Figure 24 : Larger opening to allow caulk seal
Additional isolation can be achieved by the use of rubber grommets between the top support angle on the Magic-Pak and the corresponding top turn down retaining angle on the wall sleeve.

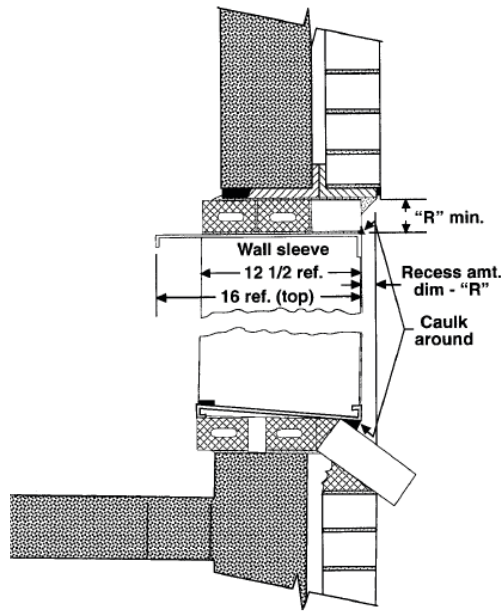

Figure 25: Larger opening to allow caulk seal

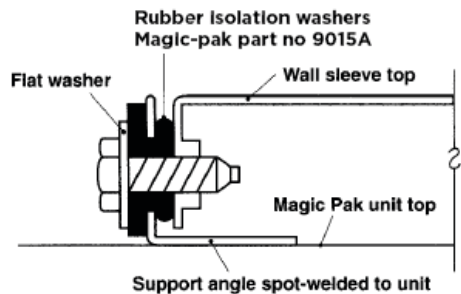

Fig 26: Enlarged cross-sectional view

It is recommended that these precautions against vibration be included unless the designer is certain that the wood-frame wall will be rigid and well-packed with insulation when completed. Please reference to local building code and ordinance. If there is any conflict with what is advised, local building codes supersede this document. For more information contact Application Specialist.

5.3 CEMENT BLOCK WALLS

Cement-block or cinder-block walls have proved to be the most forgiving for vibration and noise transmission in single or multi story buildings.

Wall sleeve openings must include a suitable lintel across the top as prescribed by local building codes. The wall sleeves may be installed from inside or outside of the building and this choice will determine the location of the side angles.

Many contractors prefer to shoot fasteners through the sides of the sleeves into the block, using the side angles as position locator. It is important that the angles be held tightly to the block along both sides while shooting the fasteners in order for the wall sleeve to finish vertical.

Either 8 in. or 12 in. block will accommodate the wall sleeve. The wall-sleeve sides are

12 -1/2 in. for 8 in. block, plus 4 in. brick facing.

The top supporting angle on the Magic-Pak is 16 in. from the outside grille face. Therefore; 12 in. block plus 4 in. brick would not permit enough protrusion to permit caulking across the bottom edge without risking plugged drain holes. In this case, the vertical dimension of the opening should be made larger by 1 in. to 2 in. to permit the use of a recessed sill on which wall sleeve can rest and still provide a means to caulk seal across the bottom without obstructing the drain holes (Fig. 25).

When the outside facing is brick, another approach has been to keep the block-wall opening the same for the wall sleeve; but the direction of the brick placed along the bottom is changed. The long dimension is placed at an angle starting underneath the wall sleeve by 1/2 inch or more, sloping downward to permit drainage, while still providing a suitable groove between the sleeve and brick in which to apply caulking material.

This can also work when recessing the sleeve, up to 2 in., even if the total wall thickness is not excessive (Fig. 25).

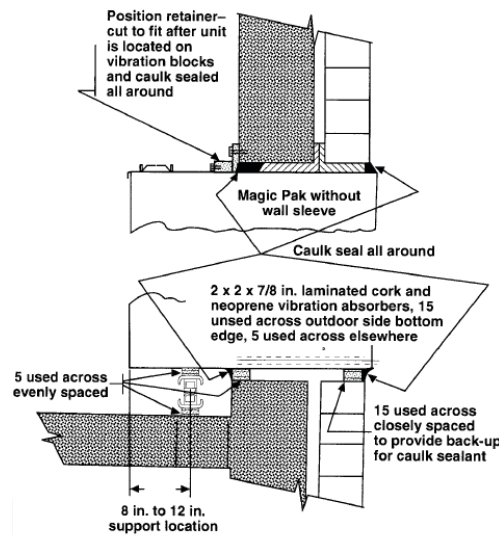

Figure 27: Vibration blocks as a stop for caulk sealant along bottom edge

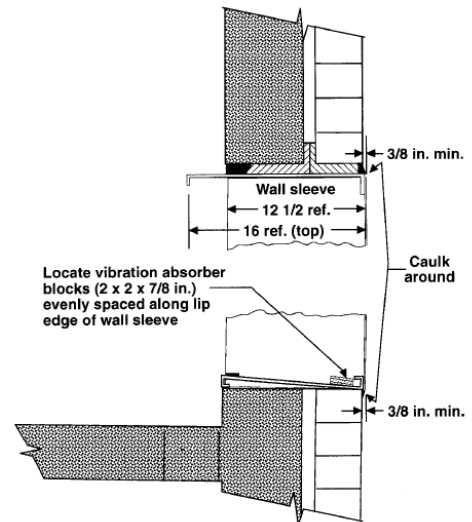

Figure 28: Vibration blocks inside the bottom of the wall

5.4 POURED CONCRETE WALLS

The use of “pre-cast” or poured-concrete walls has increased considerably in high rise, multistory building construction. These buildings require special consideration to isolate vibration. When used in conjunction with pre-stressed concrete floors, noise phenomena can occur several floors away or on an opposite side of the building. Curing these phenomena usually means isolating the unit from the wall, as well as from the floor. Vibration elimination blocks should be placed inside the bottom of the wall sleeve before the Magic-Pak unit is inserted into the wall sleeve (Fig. 27). A supplementary support should be included to isolate any vibration from the floor (Fig. 28).

5.5 METAL STUDS

Some types of construction involve the use of steel 2 in. x 4 in. channel studs in exterior walls, covered with a rigid sheathing and thick, rigid insulation panels with extensive use of adhesives. Magic-Pak wall sleeves are attached to the steel studding just as for wood, except that self-drilling screws are used with power drivers (Fig. 29).



Figure: 29: Wall sleeve fastened to steel 2” x 4” studs with screws fasteners shot through sides of wall sleeve.

6. NOISE TRANSMISSION

For duct layout and air distribution, it is better to locate a unit centrally in the floor plan. The unit can also be a utility-room, kitchen or balcony location, as opposed to a bedroom or living room location, then both duct work and sound-transmission concerns can be better served. If the floor plan does not permit the best of both worlds, there are other ways to reduce the noise perception in occupied rooms adjacent to the Magic-Pak units.

In general, the perception of noise can be traced to:

1. Vibration transmission
2. Sound radiating from the source (compressor and motors) through the panels and enclosure walls
3. Air noise
4. Resonant surfaces and objects

Noise perception by building occupants can be elusive, and early planning can address many adverse contributing factors.

6.1 VIBRATION TRANSMISSION

In spite of the efforts of rubber mounting, balancing, flexible loops of tubing and mufflers, there is always some vibration created by moving machinery, and a Magic-Pak unit is no exception. If the remaining vibration can be absorbed by the wall which supports the unit without transmitting the energy further or exciting an adjacent structural member, there is no problem. Otherwise, it is recommended additional vibration isolation using vibration pads between support stands and the floor (Figs. 21, 27 and 28), as well as between the unit and the bottom of the wall sleeve.

Concrete block walls have proved to absorb vibration better than poured-concrete walls. Wood stud wall construction can be more easily excited to re-radiate vibration unless adequately dampened by other materials. Wood stud walls which are heavily packed with fiberglass batt insulation or rock wool are less likely to re-radiate vibration than are sparsely insulated (or un-insulated walls).

Flexible duct collars must be used between the Magic-Pak plenum duct flanges and any sheet metal ducts. Also, the ducts must not be supported by, or otherwise touch, the unit.

6.2 RADIATED SOUND AND RESONANT SURFACES OR OBJECTS

In general, the sources of sound are the compressor and the rotating motors incorporating air when moving blades. A 60 Hz AC power hum can sometimes be heard from these sources or the control transformer, but generally this is imperceptible in a normal operating unit and does not contribute to any sound problem. The sound frequencies generated by the motor/compressor acting upon the refrigerant gas are a substantial contributor to the total sound radiated by the unit.

Sound frequencies generated by the action of the blades of the circulating air blower and the condenser fan blade upon air are additional sources of radiated sound. Frequently these sources of sound can transfer certain frequencies to other objects or surfaces which might in turn be resonant with some of the frequencies from these sources of sound. If this is the case, these objects or surfaces can be excited to vibrate and further impose the sound on another area.

These sound sources then radiate to enclosing panels, which are made of materials that either reflect, absorb or transmit (usually a combination of all three) certain frequencies.

Some types of materials are more “transparent” to some frequencies than others. Factors that affect this property include thickness, density and distance from the source. A closet enclosure for the Magic-Pak unit can reduce the sound level in the adjoining space if constructed with this purpose in mind.

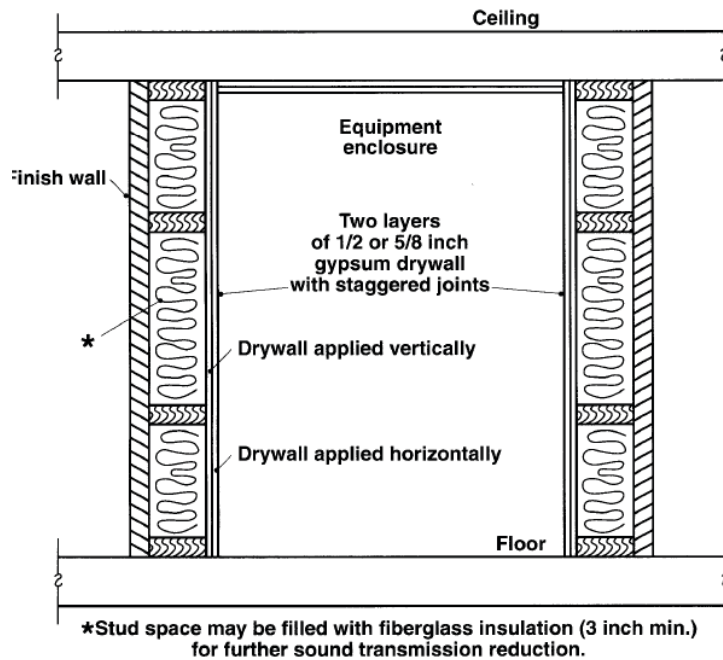

Figure 30: Line-drawing elevation cross section of closet enclosure showing two (2) layers of gypsum dry wall applied to side walls and ceiling.

6.3 CLEARANCES

The Magic-Pak cabinet is approved for zero clearances, as far as safety codes are concerned. However, if sound transmission through a wall is of major concern, a minimum dimension of 4 in. to the inside wall surface is preferred. This applies also to the front access door of the closet. Additional sound attenuation can be achieved by using two layers of gypsum dry wall (5/8 in. or 1/2 in. minimum) on the inside (Magic-Pak unit side) of the walls and the front access door of the closet (Fig. 30).

The side walls can further be improved for sound transmission if the 2 in. x 4 in. studs are fastened to 2 in. x 6 in. top and bottom plates and staggered to opposite edges of the plates on 16 in. centers. This forms a nominal 6 in. partition wall instead of the usual 4 in. wall, and permits the inside wall board and outside wall board to be fastened to studs without being tied together to the same stud. The space between the two wall surfaces may then be filled with 2-1/2 in. minimum, 1-1/2 pound density fiberglass (Fig. 31).

This same type of staggered stud wall construction may effectively be used as return-air space, where local building codes permit. Cement-block construction for the side walls of the closet enclosure has been employed successfully using a minimum thickness of 4 in. block to attenuate radiated sound. The effectiveness is further improved by adding two layers of gypsum wall board fastened to the inside wall surface by means of furring strips and structural adhesive (and/or nails).

Fiberglass or rigid polystyrene insulation may be applied between the furring strips if thermal insulation and a vapor barrier is appropriate in the building design. However, the fiberglass or polystyrene alone will not prove effective at these frequencies without two thicknesses of gypsum wall board, unless the fiberglass thickness is increased to more than 3 in.

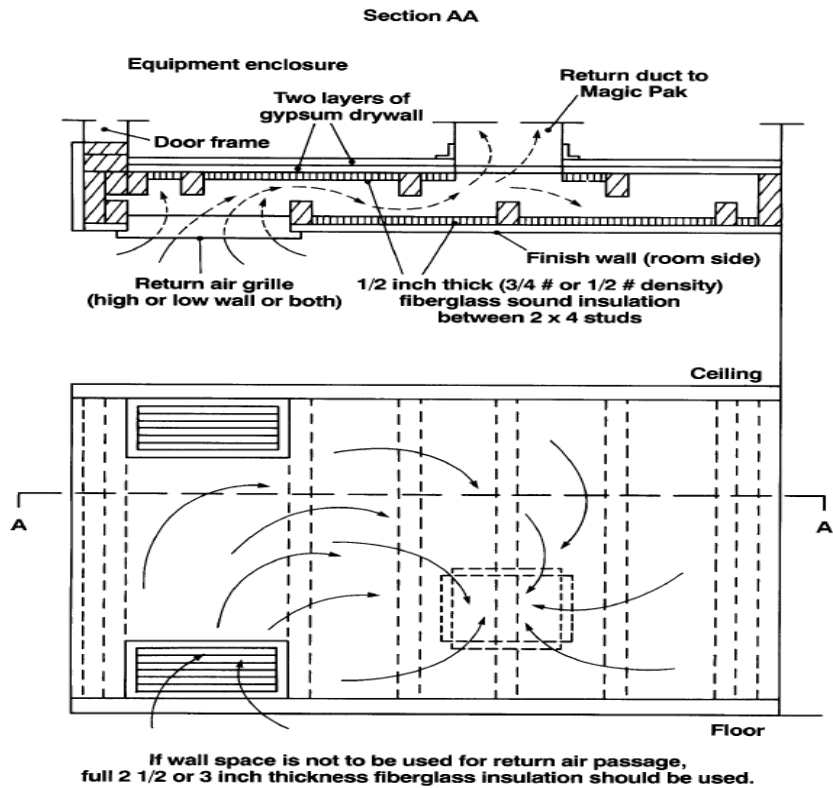

Figure 31: line drawings, plan and elevation showing cross section of walls with 2" x 4" studs staggered on wide top and bottom plate for lateral air passage

6.4 DETERMINATION OF SOUND RATING VALUES

The sound rating numbers which are listed in the AHRI Directory and are certified by manufacturers of unitary equipment under the most recent version of the AHRI standard 270 have little or nothing to do with the perceived sound characteristics of the indoor space served by the unit. These sound rating numbers (in decibels) are only useful in working with sound levels and measurements at locations outdoors and distant from the unit, such as a property line or an apartment across the courtyard.

The most recent version of the AHRI standard 275 describes how to apply the sound ratings. This serves a very useful purpose when dealing with sound ordinances and local code requirements during design and planning stages, when landscaping elements and building orientations can still be adjusted. The most recent version of the AHRI standard 275 allows one to predict sound levels at various locations, and it provides various methods for changing these levels.

Some local building codes have indoor requirements stated in terms of A-Weighted Sound Level (dBA), Noise Criteria (NC) Curves or Room Criteria (RC) Curves.

6.5 AIR NOISE

6.5.1. SUPPLY-AIR DUCT SYSTEM

Duct air velocity, air turning corners, changes in duct size, etc., can all create sound of a much different character than the vibration and radiated sounds of moving machinery. Since Magic-Pak units are usually connected to ducts for air distribution, any air noise will usually be heard at the supply registers or return-air grille in the room.

Supply ducts and the plenum on the Magic-Pak unit should be insulated to prevent condensation formation on the outside of the duct during summer operation. If the insulation is applied to the inside of the ductwork when it is made, the dual purpose of insulation and sound reduction will have been achieved.

As well, the use of no less than 1 in. thick fiberglass duct board will accomplish the same where local codes will permit.

A supply register cut into the side of the supply plenum or at the end of a very short duct is not recommended. At least 4 ft. of inside insulated duct and/or at least one turn of direction is needed to attenuate the noise in the duct or plenum.

The face velocity of air out of the supply register will ultimately determine the perception of sound from air noise. The selection tables furnished by the register manufacturer usually includes values for noise along with face velocity, throw and air friction at the required air flow for each supply register.

6.5.2. RETURN-AIR DUCT SYSTEM

More frequently, air noise involves the return-air system (or lack of it) when a return grille is simply cut into the side or the door of the closet enclosing the Magic-Pak unit. This is not recommended, since any equipment operating noise or air velocity noise in the closet can escape through the return grille unimpeded (See Fig. 32). Return air duct work is required for the gas/electric units. It needs to terminate outside the closet. Return air must not be drawn from a room where this furnace, or any other gas-fueled appliance (i.e. water heater), or carbon monoxide-producing device (i.e. wood fireplace) is installed.

This practice also frequently utilizes the closet space as a return plenum for air returning to the Magic-Pak unit and presents additional disadvantages discussed later.

If only one return-air grille is used, it should not be in 'line of sight' to the closet enclosure or the return duct opening in the bottom of the Magic-Pak unit offsetting the grille location up or sideways in a 6 in. closet side wall is one method used successfully.

Additional air-noise attenuation can be accomplished by adding 1/2 in. thick duct liner to the air passages thus created, and to the inside surface of the opposite wall facing the return grille.

If the closet enclosing the Magic-Pak is used as a return-air plenum and the return-air grille is located in one of the enclosing walls directly adjacent to the unit, the grille should be located high on the wall, rather than at floor level. Then duct liner can be placed on the inside closet walls and door to effectively reduce the air noise from the bottom of the unit. This high wall location has the advantage of minimizing "roll out" of infiltration air during high-wind conditions (Fig. 33).

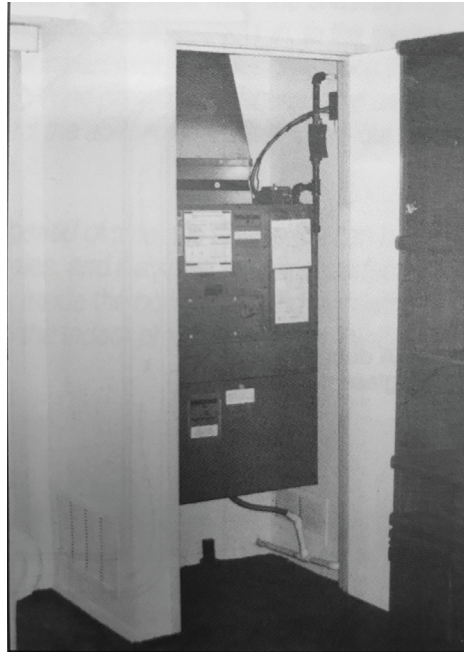

Fig. 32: Return grille with direct opening into equipment room allows noise to escape into living area and should be avoided. Also note lack of unit support at bottom

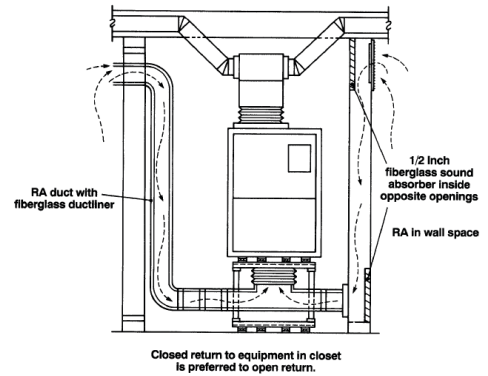

Figure 33 - Line drawing of unit isolated from ductwork, with flexible collars and closed return duct.

7. INFILTRATION

7.1 WATER INFILTRATION

Instead of relying heavily on seals and gaskets to keep the water outside, the design contains, and channels off, the water to the outside.

Air infiltration and water infiltration are most effectively addressed in different ways.

During periods of rain, an air conditioner must adequately channel large amounts of water through the appropriate drainage paths. The length of time and the amount of water received during that time determines whether or not the base pans will fill faster than they can drain. The amount of wind pressure will determine the amount of overflowed water that will be pushed past the seals and imperfections in the sheet metal joints. The chassis base takes the first water entering through the condenser coil face and the upper discharge condenser air louvers, and its sides are about 1 in. high.

If the Magic-Pak unit is recessed into the wall opening, it will also likely receive the water running down the building wall above it plus the water draining out of any units in the same wall directly above. The cabinet base takes the overflow from the chassis base and can take another 2 in. of water depth along the sides and 1 in. to the gasket joint beneath the chassis base in the return-air compartment. The design is such that all of the rain water drains to the outside by gravity. Wind pressure is generally the same over the entire outside face and should not affect the ability of the water to run out the drain holes.

If the quantity of water is excessive for a short period of time, the drain pans can be filled with water faster than it can run out the drain holes, and if a small hole or imperfection is reached by the water level, it can find its way inside the building. During high-wind conditions, the outside pressure is greater than the indoor pressure and more water can be forced through the imperfections. Even then, the inside cabinet return-air bottom frame is designed to further retain this leakage in it should occur. However, the duct flange corners, the condensate tubing passage holes, and the four corners of the inside-cabinet return-air bottom frame must be sealed at installation to prevent any drops of water from leaving the base channels or entering the return-air duct.



Figure 34: Inside of unit at return-air duct flange, showing sealed condensate tube opening

7.2 AIR INFILTRATION

The load added to the Magic-Pak units for both sensible and latent heat of the outside air entering the conditioned space must be included in the heat loss/gain calculations in accordance with standard practice.

The amount of outside air that enters the space by infiltration through the Magic-Pak unit itself, and the wall sleeve, must also be included in this calculation.

For applications in high wind areas, such as high rise buildings, the amount of infiltration can be assumed to be minimal. An average of 15-30 CFM of infiltration can be used for calculation purposes. Wind conditions below 30 miles per hour can be considered as no (too low to measure) CFM air infiltration through the Magic-Pak unit and wall sleeve.

If the closet enclosure is on a balcony, it would not need to be sealed or gasketed around the access door as would an enclosure with an access door opening into the conditioned space.

7.3 INTRODUCTION OF VENTILATION AIR

Some local building codes require that a specific amount of ventilation be brought into the conditioned space depending upon the occupancy and use of the building. In order to comply, some builders will install a short duct with a fixed damper to the outside wall from the return duct or plenum space.

A grille is placed over the opening in the outside wall. The grille should be backed up with a piece of screening to prevent insects from entering.

This method is particularly useful in keeping the space under a slight positive pressure; however, controlling the amount of air entering the duct under high-wind conditions in high-rise buildings is very unpredictable.

7.4 SEALING RETURN-AIR DUCTS

Whenever return ducts are connected directly to the inlet of a Magic-Pak using flexible duct collars, care should be taken to seal all cracks, holes, and joints against air leaks, if the enclosing closet can be pressurized by high wind and an unsealed wall sleeve.

If the return-air grille is high in the sidewall or access door and connected by a duct coming down to the return location in the unit, the effect of leaky return ductwork and high wind pressure during an off cycle can be reduced, but not necessarily eliminated.

7.5 SEALING WALL SLEEVE

It is preferable to seal the space between the unit and the wall sleeve with expanding foam polyurethane sealant insulation or some other suitable caulking material (Figs.35).

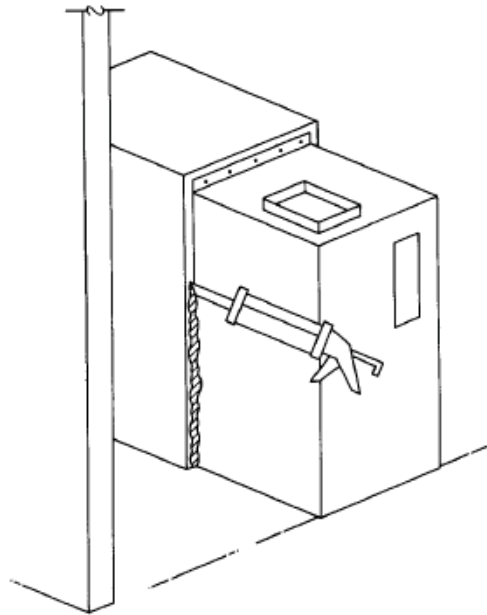

Fig 35: For additional protection against air infiltration during periods of very high winds, fill the clearance space between unit and wall sleeve all around with polyurethane foam sealant.

8. OUTSIDE DECORATIVE FACADES, GRILLES OR LOUVERS

8.1 GRILLE AND LOUVER FURNISHED ON MAGIC-PAK

The appearance from outside is the same for all Magic-Pak models of any heating or cooling capacity. The upper louvered grille is the same for all models. (Note: HWC9 Models have small cut out at flue pipe termination.)

The louvers in this upper grille are turned slightly upward to direct discharge air away from the intake of the condenser coil below it, to minimize recirculation of air, and to present a better appearance by avoiding line-of sight observation of the space and action taking place behind the louvered grille.

The lower grille covering the condenser coil is on the intake side of the condenser coil, which can be more easily cleaned from the outside where dirt, leaves and other airborne debris can collect, as opposed to a “blow through” design which deposits this debris on the inaccessible side of the coil. In buildings over three stories, the likelihood of collecting such debris on the outside is very much reduced, and the action of rain and other elements ordinarily will clean away any accumulation.

If it becomes necessary to remove the upper and lower grilles for painting, cleaning or repair, they can be removed from inside the building. To remove the grilles, first remove the slide-out chassis, and reaching in, hold onto the bottom edge of the lower grille and pull it toward you to completely remove it. Since the lower grille holds the upper louver in place, the upper louver can now be pulled straight down (like closing a window) into the space formerly occupied by the lower grille and likewise be removed. Simply reverse the procedure to replace these parts and the chassis.

The upper louver is held in place by the lower grille and, as a safety feature, neither can fall outward without considerable maneuvering effort.

Also, the lower grille is held in place by the inserted chassis. Even with the chassis removed, the lower grille should stay in place to keep the opening covered until it is purposely removed.

8.2 OUTSIDE APPEARANCE VARIATIONS

Magic-Pak units eliminate the unsightly appearance of external condensers and cooling towers, and integrate unobtrusively into the building design. The neutral-toned, grille finish complements any exterior wall. In addition, Architectural louvers can sometimes be placed over the outside of the Magic-Pak units, but not all designs are suitable.

Tests have been run in the laboratory to find out what effect several different designs have on the performance and longevity of the Magic-Pak units. Almost every obstacle to air flow placed near the outside grilles showed some deterioration of performance. In the least successful designs, problems resulted from recirculation of air between the upper condenser air discharge and the lower condenser air intake. When using a custom 3rd party louver with Magic-Pak, there are a few things to consider.



Fig. 36: V-Series Louver

Elimination of a recirculation path by the use of a tight fitting close-out baffle installed horizontally between the grille or facade and the unit at the top edge of the condenser coil is vital to prevention of recirculation. Beyond that, providing sufficient free area for intake and discharge condenser air, as specified in Fig. 37, has usually resulted in satisfactory performance. It is still not considered good practice to use a louvered grille which has all of the louvers pointing downward.

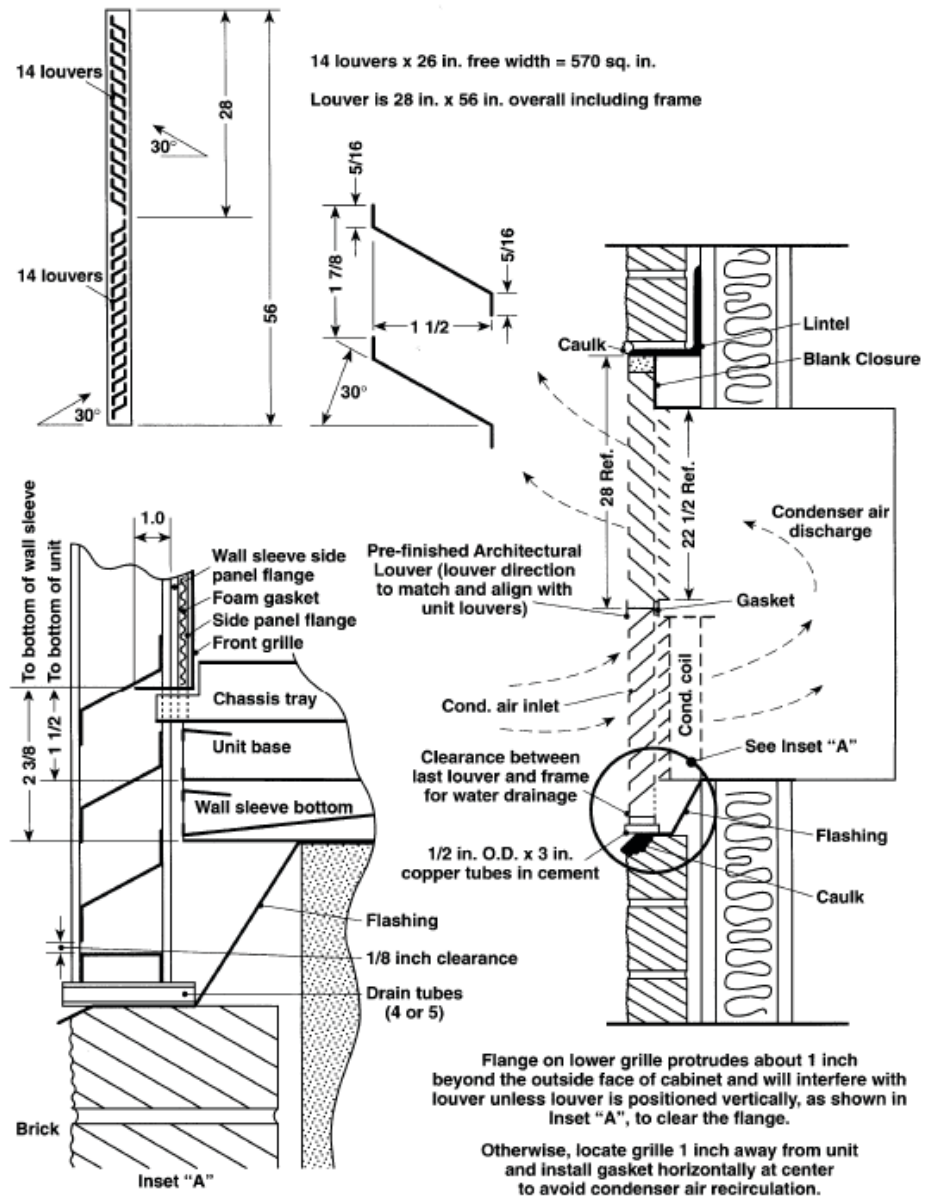

Fig 37. Louver facade shown in cross section and enlarged section with dimensions.

A grille which has the upper section of louvers pointing upward and the lower louvers pointing downward, and are at no more than a 45° angle from horizontal, can work satisfactorily against the outside of the unit, if the louvers are flat and thin (1/8 in. maximum) and have vertical mullions to prevent vibration and noise. The grille must have a free air face dimension (inside its frame) at least as large as the unit, and preferably 2 in. to 4 in. higher at the top, for less impingement of condenser discharge air, and 2 in. to 4 in. lower at the bottom to permit water drain-age out through the louvers (Fig. 41). On HWC models, a field installed architectural grille must have an unobstructed opening for flue gases to pass through. The flue must be extended and flush with the new louver. This will reduce the possibility of ice build up on the grille.

If the Magic-Pak unit and such a grille are to be separated by more than 1 in., a horizontal baffle must be used to prevent recirculation of condenser air behind the grille. Also, flashing must be installed between the bottom of the wall sleeve (or unit) and the grille frame if the space is a result of recessing the unit.

If such a grille is held away from the building and the Magic-Pak such that the bottom of the grille is open, flashing would not be required.

Blowing rain or snow must drain freely from the unit. At the same time it must not be permitted to drain behind a facade or added grille causing water damage to the building or floors below.

A 3 in. or 4 in. diameter duct/tube fastened to the decorative grille, concentric with the flue tube and pitched slightly downward (away from the unit) may last if made of aluminum or galvanized steel; but a better material choice would be a non-metallic, high-temperature flue pipe material in 3 in. or 4 in. diameter.

CAUTION:

After leaving the factory, the HWC unit venting system must not be altered in any way. Agency Approvals can become void if any modifications to the HWC unit is attempted.

8.3 CONSIDERATIONS FOR CUSTOM LOUVERS

For our M-Series™ and V-Series™ line of equipment, Magic-Pak offers factory tested and approved architectural louvers. These louvers are designed specifically for our equipment and have been through performance and reliability testing to ensure the unit will perform as intended.

We know in many cases developers and architects may have local building codes that require louvers to be “hidden” or have a very specific look and design. In those situations, custom louver solutions are often developed.

Outlined below is a list of design criteria that if met, will ensure proper unit operation and maintain the equipment’s factory warranty. Any deviation from the below guidelines will result in the warranty being void.

1. Louvers must maintain their bidirectional louver blades where condenser exhaust louver blades are directed up and condenser intake louver blades are pointed downward. The pitch of the blades is not to exceed 45 degrees.
 - a. If a unidirectional louver is desired, it must be used with our factory louver, spaced at least 4” from the factory louver, maintain a tight division panel between the intake and exhaust, offer 70% free area, and be at least 2” taller at the top and bottom than our factory louver.
2. The cross section area for the condenser air intake and exhaust must not be less than the area available from the factory wall sleeve.
3. 70% free area on the face of any louver is required.
4. The division between condenser air intake and exhaust must always be maintained.
 - a. If units are in a vertical array and covered with a continuous louver, it is necessary to have division panels between floors as well.
5. For gas / electric units:
 - a. The flue pipe must meet the back of the louver on 80% models.
 - i. No farther than 1.5” of separation.
 - b. For condensing gas furnaces, the flue pipe must be flush with the face of the louver and not obstructed in any way.
 - c. Flue pipe extensions should not be attached to the existing flue pipe, but there should be a concentric pipe that extends to the louver and attaches to the building or wall sleeve.
 - i. Flue pipe extensions should not exceed 36”.
 - d. As with any gas burning furnace, flue exhaust is mildly acidic; selected materials must withstand typical flue temperatures and exposure to condensate.
 - i. 80% - a maximum of 300 degrees on V-Series and a maximum of 400 degrees on M-Series.
 - ii. 95% - standard 2” PVC may be utilized.
6. Factory louvers and wall sleeves are designed to shed excess rain water and condenser condensate overflow out of the bottom of the louver. This must not be obstructed by a 3rd party louver solution. Proper sealing and flashing is required.

Therefore, any references here to the flue tube extensions or baffles should be interpreted as being fastened to or held in place by the decorative facade or louver itself or by some means other than attached to or touching the upper grille of the HWC unit. Any extension flue tube must not approach the upper grille of the HWC unit any closer than one inch.

The Magic-Pak may be located right up to a grille, provided the height of the grille is more than the height of the unit and the center portion of the grille (where the louver direction reverses from up to down) is in line with a 2 in. wide space just above the top edge of the condenser coil.

The bottom of the unit must still be flashed to the bottom edge of the louver, unless other provisions are made to prevent water from entering the building (Fig. 37). Do not attach anything to the slide-out chassis edge (where it protrudes from the unit cabinet) which might inhibit removal of the chassis or cause a seal to be broken in removal of the chassis.

Fig. 36 provides a sketch of a suitable louver. With this particular louver design, there is no need to remove the grilles from the unit or to add a bird screen to the louver. This louver extends above and below the unit to provide better airflow and water drainage. These are examples of a few of the grilles and facades in use throughout the country.

Not all have been documented for performance once deterioration, but if the designer stays within the guidelines of the recommendations stated here, satisfactory performance and service life will result.

8.4 CONTROL OF SOUND WITH LOUVERED GRILLES

Another type of decorative grille has been used to control sound. This grille utilizes large louvers placed vertically and mounted at an angle to deflect sound away from glass areas which are in an adjacent wall. The grille is often painted to match the building and does not detract from the building's appearance. The large air passages and vertical assembly do not contribute to performance deterioration by reason of recirculation or restriction of condenser air.

9. CONDENSATE

9.1 CONDENSATE DRAIN

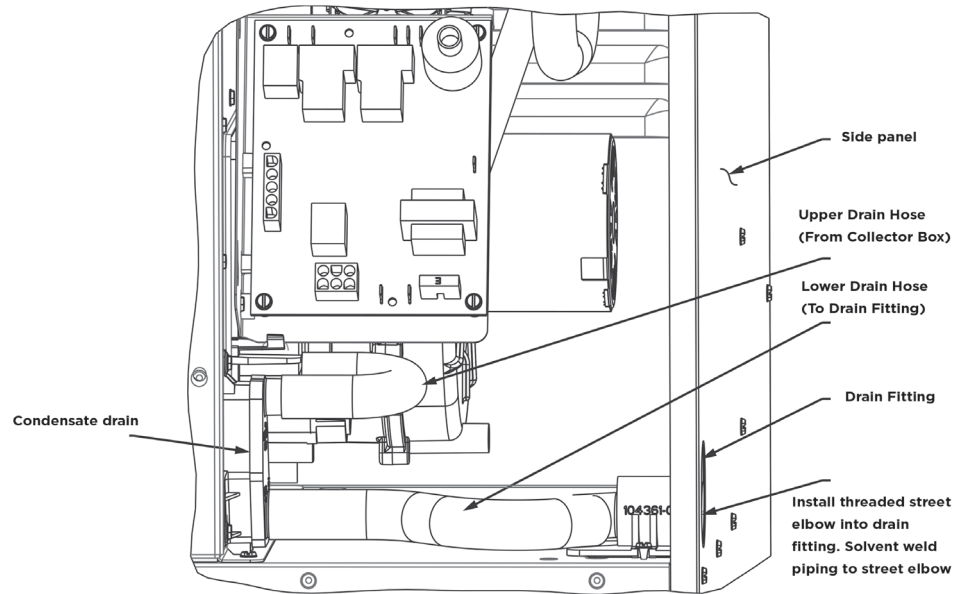

Fig 38b. Installed Evaporator Condensate Drain

The HWC9 Magic-Pak units have a factory installed condensate furnace drain. It is not suggested or required to have a second trap added to the field installed drain. A second trap may result in slow or possibly no draining of the furnace condensate.

Piping the condensate to an inside drain is consistent and reliable and should provide many years of trouble free service. Provision must be made to accept the condensate. The connection to the condensate collection pan is located in the center of the pan directly below the air filter.

A length of clear plastic tubing with a heavy wall thickness (to prevent kinking) is provided (see Fig 38). One end slips tightly over the stub-tube connection on the pan. The clear tubing is looped to form a trap, then slipped over a piece of 5/8 in. O.D. copper tubing (or PVC tubing) and connected to a drain according to local codes. The Magic-Pak HWC9 high efficiency unit has an additional condensate drain port for the furnace in addition to the air conditioning condensate drain port.

9.2 HIGH EFFICIENCY UNITS

Units that run at 90% and above efficiency produce a condensate that is not potent. The condensate range of high efficiency furnaces is mildly acidic and falls in the 2 to 5 range on the pH scale of acidity and alkalinity. Figure 1 below compares the relative pH of some common liquids to furnace condensate of any 90%+ gas furnace, including Magic-Pak 90%+ gas/electric units. The concentration level of the acidity of all these fluids including the condensate is very low and harmless to the environment. See Fig 39. If Local codes require an acid neutralizer, it is available as an accessory.

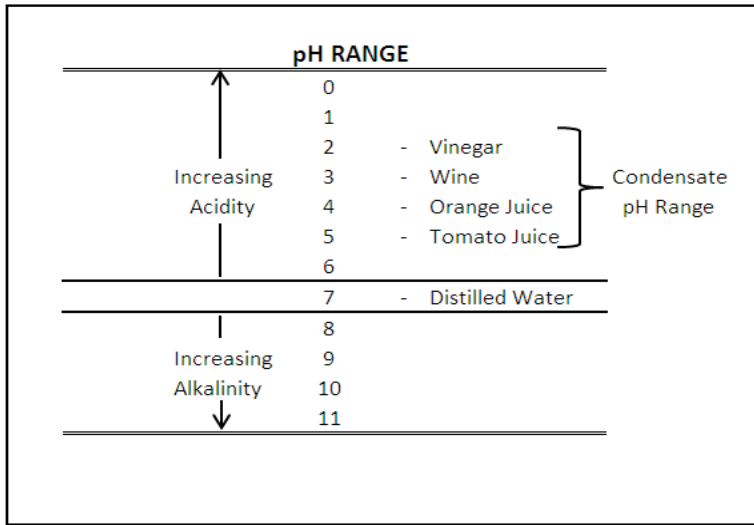

Fig 39. Condensate pH Range for 90%+ Gas Furnaces and 90%+ Magic-Pak Gas/Electric Units

Each Magic-Pak model is shipped with installation instructions which describe the options for electrical supply wiring connections to the specific unit model. All instructions defer to the code requirements of the agencies of local jurisdiction.

10. ELECTRICAL SERVICE WIRING

In most cases, the HWC gas-fired Magic-Pak units will be connected to nominal 208/230 volt, 60 Hz, single-phase power. The same units can be connected to 208 volt power if assurances can be given by the power supplier that a minimum of 197 volts will always be available. Cooling capacities will be reduced by about 1% for 208 volt operation. Gas heating ratings are not affected. The EWC electric units affected on the cooling cycle in a manner similar to the HWC models, as described above. However, since the EWC heat pump model contains electric resistance. Resistance strip heaters in the heating cycle, the supply line voltage has a bearing on the heating output of the strip heaters.

The “rated” voltage of the heaters is 208/230 volts. The nominal KW is for a 240-volt rating.

The remainder of the Magic-Pak unit is rated at 230 volts, but has an operating voltage range from 253 to 197 volts, in accordance with the AHRI Standard 210/240.

The actual BTUH output of the electric strip heaters varies with the square of the voltage ratio; so if the expected operating voltage at a job location is known or can be determined, the actual heater output can be determined, or a heater optional size can be selected to meet a heating requirement at any chosen voltage.

Example:

- At 240 volts, 9.2 KW delivers 31,400 BTUH
- At 208 volts, the same heater delivers

$$\left(\frac{208}{240}\right)^2 \times 9.2 = 6.9 \text{ KW or } 23,550 \text{ BTUH}$$

The heat output for any other application voltage may be determined in the same way.

The specification sheets for each model also include the ampacity values required to determine wire sizes, in addition to the minimum fuse size requirements for both single entry and multiple entry connections to the units.

11. AIR FILTER

All Magic-Pak units are equipped with an air filter covering the entering face of the indoor coil in the slide-out chassis. This air filter is accessible for replacement or cleaning by removal of the lower front compartment cover.

In the event that a wall or ceiling register containing an air filter is selected for use in the return system, the filter in the chassis should be removed. The return-air duct system should be tight from the filter to the coil in the chassis, and a closed duct-return connection to the unit must be used.

Access for removal of the cooling chassis must not be compromised; however, all of the air entering the cooling coil must be filtered.

The external filter grille (or grilles, if more than one is to be used) should be selected for a face velocity not to exceed 300 ft. per minute, or an air friction not in excess of 0.12 in. W.G.

12. SPECIAL CONSIDERATION FOR GAS UNITS

One of the advantages of Magic Pak units is that combustion air is not taken from the occupied space.

Gas-fired Magic-Pak's take combustion air directly from the outside in close proximity to the flue-gas discharge tube. Since the two openings are close enough physically to be nearly at the same pressure under various wind conditions, combustion is affected very little by high wind pressure.

A centrifugal combustion-air blower provides the displacement and pressure required to overcome the internal resistance of the heat-exchanger passages, while drawing in the correct amount of air for efficient combustion.

The materials used in the construction of the heat exchanger, combustion blower, flue gas discharge tube and outside louver grille are consistent with the requirements for corrosion resistance for the application, and consider the presence of moisture and the formation of acids through condensation internally and externally on the louvered grille. The flue-gas velocity and temperature are usually high enough to project the gases beyond the louvered grille before they condense, but in the event that erratic wind conditions could blow them back, the corrosion protection is provided. If a decorative grille or facade is contemplated, please contact our support team.

