

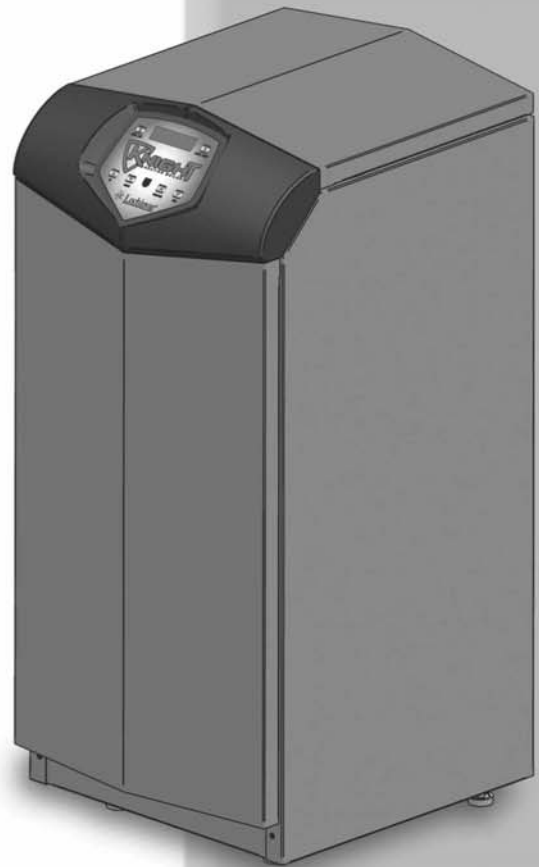

# Installation & Operation Manual

## Models: 80 - 500

CLICK ANYWHERE on THIS PAGE to RETURN to LOCHINVAR HEATER INFORMATION & MANUALS at [InspectApedia.com](http://InspectApedia.com)



### WARNING

This manual must only be used by a qualified heating installer / service technician. Read all instructions, including this manual and the Knight Boiler Service Manual, before installing. Perform steps in the order given. Failure to comply could result in severe personal injury, death, or substantial property damage.



Save this manual for future reference.

# Contents

<b>Hazard definitions</b> .....	<b>2</b>
<b>Please read before proceeding</b> .....	<b>3</b>
<b>The Knight Boiler -- How it works</b> .....	<b>4</b>
<b>Ratings</b> .....	<b>7</b>
<b>1. Determine boiler location</b> .....	<b>8</b>
<b>2. Prepare boiler</b> .....	<b>12</b>
<b>3. General venting</b> .....	<b>14</b>
<b>4. Sidewall direct venting</b> .....	<b>18</b>
<b>5. Vertical direct venting</b> .....	<b>24</b>
<b>6. Hydronic piping</b> .....	<b>28</b>
<b>7. Gas connections</b> .....	<b>38</b>
<b>8. Field wiring</b> .....	<b>42</b>
<b>9. Condensate disposal</b> .....	<b>46</b>
<b>10. Start-up</b> .....	<b>47</b>
<b>11. Operating information</b> .....	<b>54</b>
<b>12. Notes page</b> .....	<b>66</b>

---

## Hazard definitions

The following defined terms are used throughout this manual to bring attention to the presence of hazards of various risk levels or to important information concerning the life of the product.

### DANGER

DANGER indicates an imminently hazardous situation which, if not avoided, will result in death or serious injury.

### WARNING

WARNING indicates a potentially hazardous situation which, if not avoided, could result in death or serious injury.

### CAUTION

CAUTION indicates a potentially hazardous situation which, if not avoided, may result in minor or moderate injury.

### CAUTION

CAUTION used without the safety alert symbol indicates a potentially hazardous situation which, if not avoided, may result in property damage.

### NOTICE

NOTICE indicates special instructions on installation, operation, or maintenance that are important but not related to personal injury or property damage.

## Please read before proceeding

### ⚠ WARNING

**Installer** – Read all instructions, including this manual and the Knight Boiler Service Manual, before installing. Perform steps in the order given.

**User** – This manual is for use only by a qualified heating installer/service technician. Refer to the User's Information Manual for your reference.

Have this boiler serviced/inspected by a qualified service technician, at least annually.

Failure to comply with the above could result in severe personal injury, death or substantial property damage.

### NOTICE

When calling or writing about the boiler – Please have the boiler model and serial number from the boiler rating plate.

Consider piping and installation when determining boiler location.

Any claims for damage or shortage in shipment must be filed immediately against the transportation company by the consignee.

Factory warranty (shipped with unit) does not apply to units improperly installed or improperly operated.

### ⚠ WARNING

Failure to adhere to the guidelines on this page can result in severe personal injury, death, or substantial property damage.

### ⚠ WARNING

If the information in this manual is not followed exactly, a fire or explosion may result causing property damage, personal injury or loss of life.

This appliance **MUST NOT** be installed in any location where gasoline or flammable vapors are likely to be present.

#### WHAT TO DO IF YOU SMELL GAS

- Do not try to light any appliance.
- Do not touch any electric switch; do not use any phone in your building.
- Immediately call your gas supplier from a neighbor's phone. Follow the gas supplier's instructions.
- If you cannot reach your gas supplier, call the fire department.
- Installation and service must be performed by a qualified installer, service agency, or the gas supplier.

### When servicing boiler –

- To avoid electric shock, disconnect electrical supply before performing maintenance.
- To avoid severe burns, allow boiler to cool before performing maintenance.

### Boiler operation –

- Do not block flow of combustion or ventilation air to the boiler.
- Should overheating occur or gas supply fail to shut off, do not turn off or disconnect electrical supply to circulator. Instead, shut off the gas supply at a location external to the appliance.
- Do not use this boiler if any part has been under water. The possible damage to a flooded appliance can be extensive and present numerous safety hazards. Any appliance that has been under water must be replaced.

### Boiler water –

- Thoroughly flush the system (without boiler connected) to remove sediment. The high-efficiency heat exchanger can be damaged by build-up or corrosion due to sediment.
- Do not use petroleum-based cleaning or sealing compounds in the boiler system. Gaskets and seals in the system may be damaged. This can result in substantial property damage.
- Do not use “homemade cures” or “boiler patent medicines”. Serious damage to the boiler, personnel, and/or property may result.
- Continual fresh make-up water will reduce boiler life. Mineral buildup in the heat exchanger reduces heat transfer, overheats the stainless steel heat exchanger, and causes failure. Addition of oxygen carried in by makeup water can cause internal corrosion. Leaks in boiler or piping must be repaired at once to prevent makeup water.

### Freeze protection fluids –

- NEVER use automotive antifreeze. Use only inhibited propylene glycol solutions, which are specifically formulated for hydronic systems. Ethylene glycol is toxic and can attack gaskets and seals used in hydronic systems.

# The Knight Boiler - How it works...

## 1. Stainless steel heat exchanger

Allows system water to flow through specially designed coils for maximum heat transfer, while providing protection against flue gas corrosion. The coils are encased in a jacket that contains the combustion process.

## 2. Heat exchanger access cover

Allows access to the combustion side of the heat exchanger coils.

## 3. Blower

The blower pulls in air and gas through the venturi (item 5). Air and gas mix inside the blower and are pushed into the burner, where they burn inside the combustion chamber.

## 4. Gas valve

The gas valve senses the negative pressure created by the blower, allowing gas to flow only if the gas valve is powered and combustion air is flowing.

## 5. Venturi

The venturi controls air and gas flow into the burner.

## 6. Flue gas sensor

This sensor monitors the flue gas exit temperature. The control module will modulate and shut down the boiler if flue gas temperature gets too hot. This protects the flue pipe from overheating.

## 7. Boiler outlet temperature sensor

This sensor monitors boiler outlet water temperature (system supply). If selected as the controlling sensor, the control module adjusts boiler firing rate so the outlet temperature is correct.

## 8. Boiler inlet temperature sensor

This sensor monitors return water temperature (system return). If selected as the controlling sensor, the control module adjusts the boiler firing rate so the inlet temperature is correct.

## 9. Temperature and pressure gauge (field installed, not shown)

Monitors the outlet temperature of the boiler as well as the system water pressure.

## 10. Electronic display

The electronic display consists of 7 buttons and a dual line 32-character liquid crystal display.

## 11. Flue pipe adapter

Allows for the connection of the PVC vent pipe system to the boiler.

## 12. Burner (not shown)

Made with metal fiber and stainless steel construction, the burner uses pre-mixed air and gas and provides a wide range of firing rates.

## 13. Water outlet (system supply)

NPT water connection that supplies hot water to the system, either 1", 1-1/4", or 1-1/2", depending on the model.

## 14. Water inlet (system return)

NPT water connection that returns water from the system to the heat exchanger, either 1", 1-1/4", or 1-1/2", depending on the model.

## 15. Gas connection pipe

Threaded pipe connection, either 1/2", 3/4", or 1", depending on the model. This pipe should be connected to the incoming gas supply for the purpose of delivering gas to the boiler.

## 16. SMART Control Module

The SMART Control responds to internal and external signals and controls the blower, gas valve, and pumps to meet the heating demand.

## 17. Automatic air vent

Designed to remove trapped air from the heat exchanger coils.

## 18. Air intake adapter

Allows for the connection of the PVC air intake pipe to the boiler.

## 19. High voltage junction box

The junction box contains the connection points for the line voltage power and all pumps.

## 20. Boiler drain port

Location from which the heat exchanger can be drained.

## 21. Low voltage connection board

The connection board is used to connect external low voltage devices.

## 22. Low voltage wiring connections (knockouts)

Conduit connection points for the low voltage connection board.

## 23. Condensate drain connection

Connects the condensate drain line to a 1/2" PVC union.

## 24. Access cover - front

Provides access to the gas train and the heat exchanger.

## 25. Ignition electrode

Provides direct spark for igniting the burner.

## 26. Flame inspection window

The quartz glass window provides a view of the burner surface and flame.

## 27. Gas shutoff valve

Manual valve used to isolate the gas valve from the gas supply.

## 28. High limit sensor

Device that monitors the outlet water temperature. If the temperature exceeds its setting, it will break the control circuit, shutting the boiler down.

## 29. Relief valve

Protects the heat exchanger from an over pressure condition. The relief valve may be set at 30 psi or 50 psi depending on model.

## 30. Flame sensor

Used by the control module to detect the presence of burner flame.

## 31. Line voltage wiring connections (knockouts)

Conduit connection points for the high voltage junction box.

## 32. Top panel

Removable panel to gain access to the internal components.

## 33. Power switch

Turns 120 VAC ON/OFF to the boiler.

## 34. Leveling legs

Used to allow the heat exchanger to be leveled. This is needed for the proper draining of the condensate from the combustion chamber.

# The Knight Boiler - How it works... *(continued)*

## Models 80 - 210

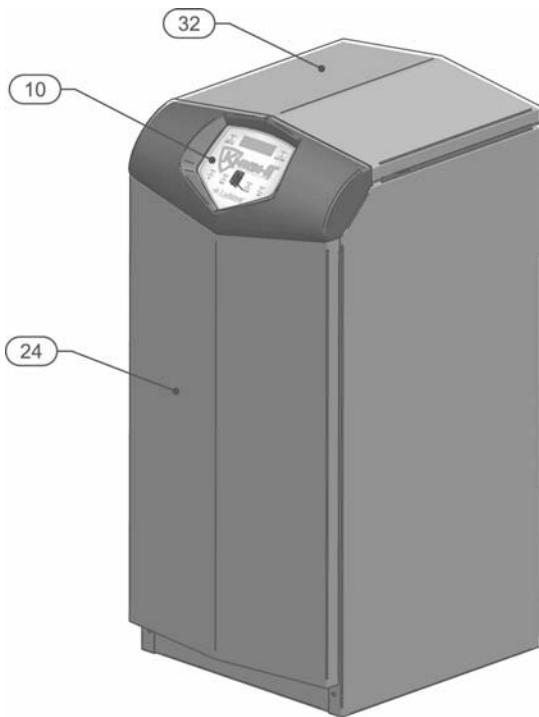

Figure 1 Front View - Models 80 - 210

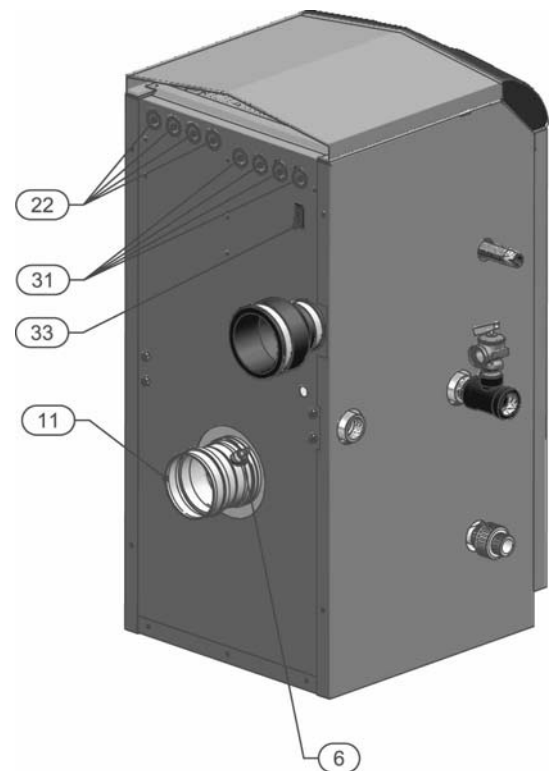

Figure 2 Rear View - Models 80 - 210

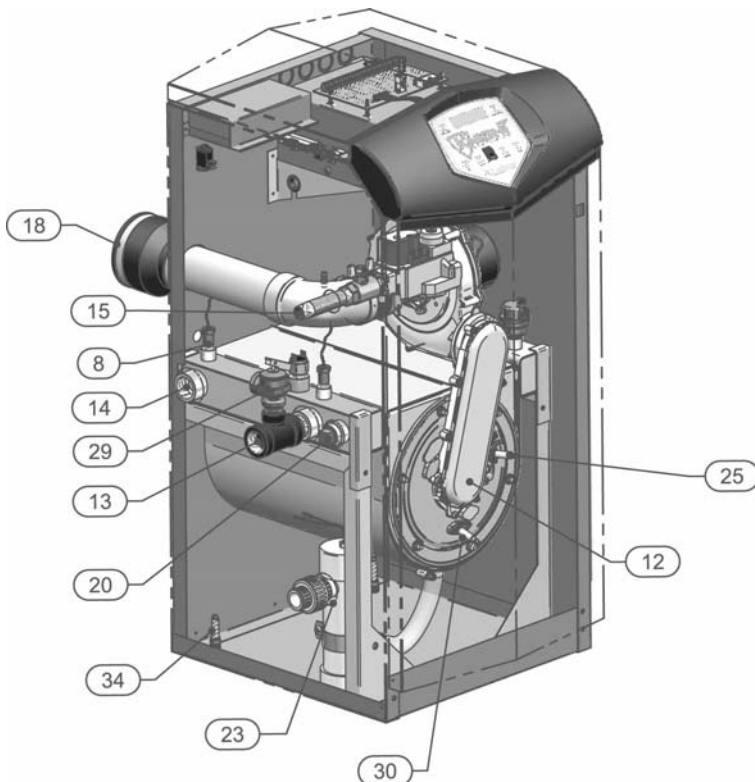

Figure 3 Left Side (inside unit) - Models 80 - 210

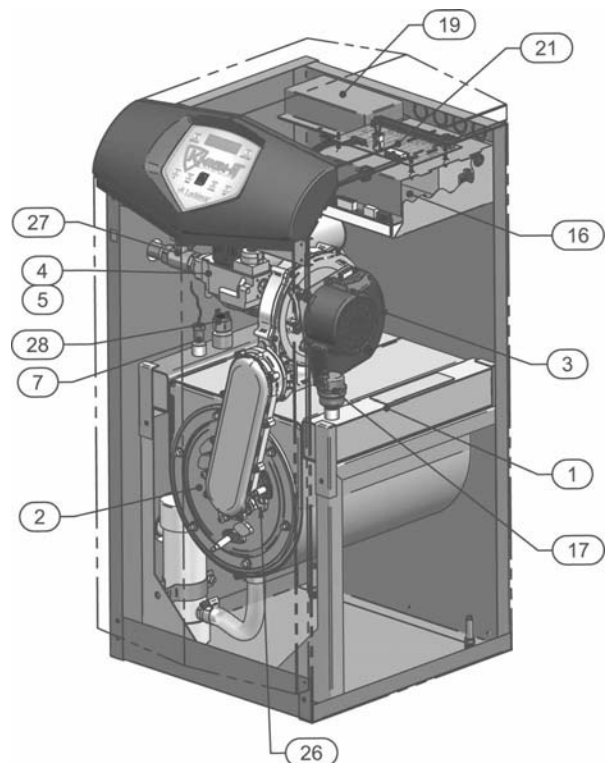

Figure 4 Right Side (inside unit) - Models 80 - 210

# The Knight Boiler - How it works...

## Models 285 - 399

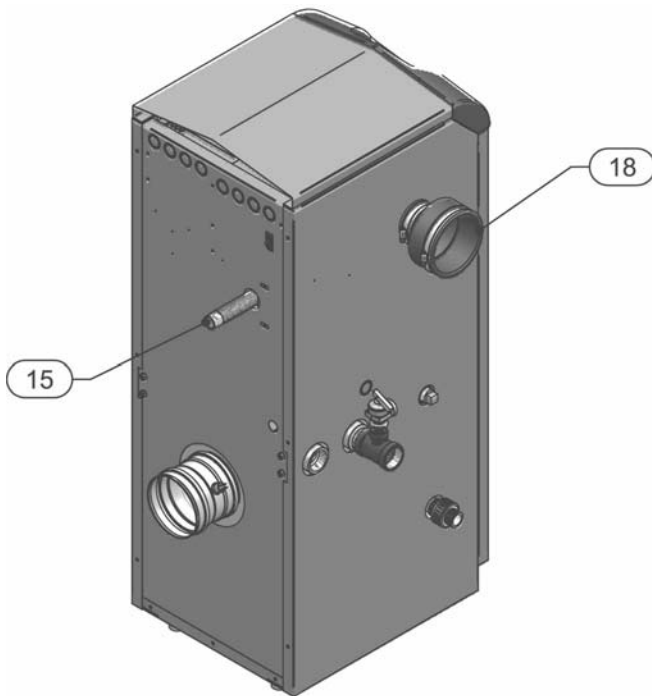

Figure 5 Rear View - Models 285 - 399

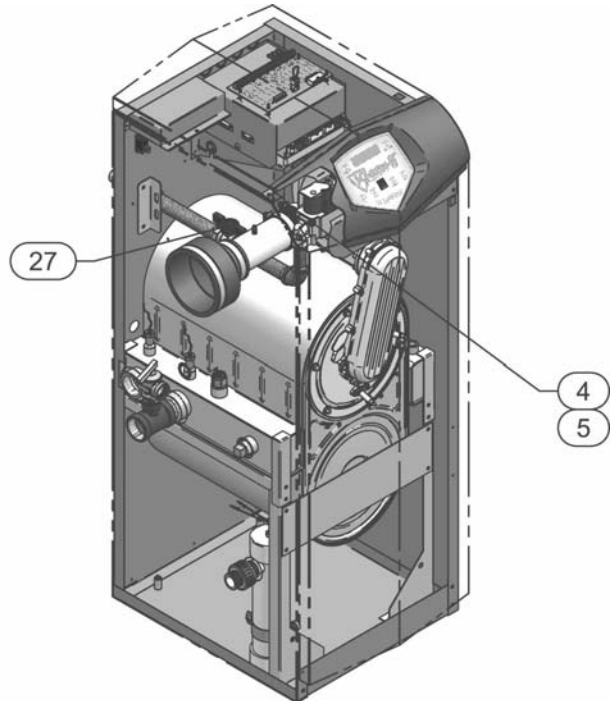

Figure 6 Left Side (inside unit) - Models 285 - 399

## Model 500

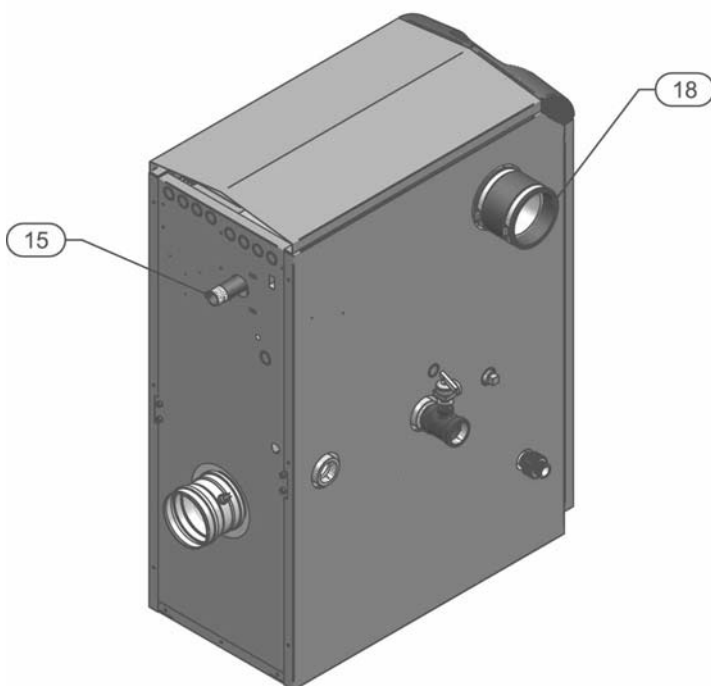

Figure 7 Rear View - Model 500

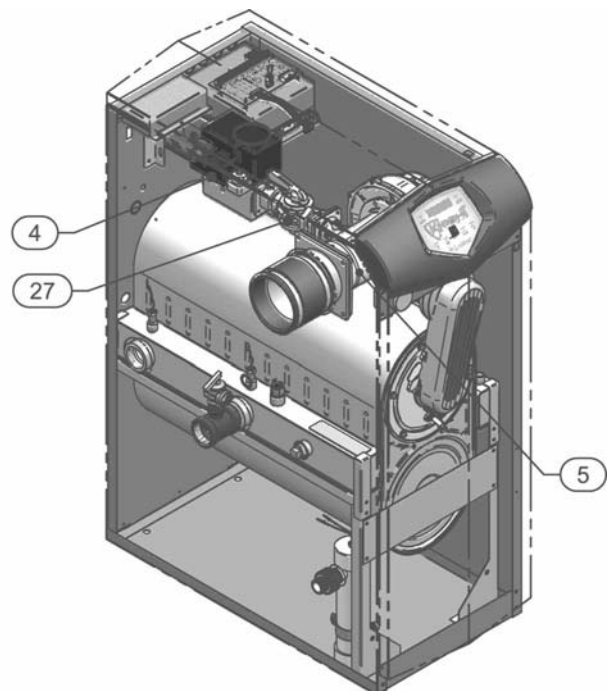

Figure 8 Left Side (inside unit) - Model 500

# Ratings



DOE



Model Number  Note: Change "N" to "L" for L.P. gas models.	CSA Input Modulation Btu/hr	DOE Heating Capacity Btu/hr	Net I=B=R Ratings Btu/hr	DOE AFUE %	Lochinvar Low Temperature Application Annual Efficiency %	Boiler Water Content Gallons	Water Connections	Gas Connections	Vent/Air Size
	(Note 6)	(Note 2, 9)	(Note 3, 9)	(Note 1, 9)	(Note 5)				(Note 4)
KBN080	16,000 - 80,000	73,000	63,000	93.0	98.0	0.6	1"	1/2"	3"
KBN105	21,000 - 105,000	95,000	83,000	93.0	98.0	0.7	1"	1/2"	3"
KBN150	30,000 - 150,000	136,000	118,000	93.0	98.0	1.3	1"	1/2"	3"
KBN210	42,000 - 210,000	191,000	166,000	93.0	98.0	1.7	1"	1/2"	3"
KBN285	57,000 - 285,000	259,000	225,000	93.0	98.0	2.4	1-1/4"	3/4"	4"

Model Number  Note: Change "N" to "L" for L.P. gas models.	CSA Input Modulation Btu/hr	Gross Output, Btu/hr	Net I=B=R Ratings Btu/hr	Combustion Efficiency %	Thermal Efficiency %	Lochinvar Low Temperature Efficiency %		Boiler Water Content Gallons	Water Connections	Gas Connections	Vent/Air Size
	(Note 6)	(Note 6, 9)	(Note 3, 9)	(Note 7, 9)	(Note 7, 9)	Combustion %	Thermal %				(Note 4)
KBN399	80,000 - 399,000	360,000	313,000	92.2	90.3	95.4	94.5	3.4	1-1/2"	1"	4"
KBN500	100,000 - 500,000	451,000	392,000	92.2	90.3	95.4	94.5	4.2	1-1/2"	1"	4"

**NOTICE** Maximum allowed working pressure is located on the rating plate.

### Notes:

- As an Energy Star Partner, Lochinvar has determined that Knight boilers meet the Energy Star guidelines for energy efficiency.
- The ratings are based on standard test procedures prescribed by the United States Department of Energy.
- Net I=B=R ratings are based on net installed radiation of sufficient quantity for the requirements of the building and nothing need be added for normal piping and pickup. Ratings are based on a piping and pickup allowance of 1.15.
- Knight boilers require special gas venting. Use only the vent materials and methods specified in the Knight Installation and Operation Manual.
- Lochinvar's Low Temperature Application Annual Efficiency is based on ASHRAE 103 test method, using a boiler return water temperature of 90°F, with a boiler outlet water temperature of 110°F. This rating was conducted by Lochinvar.

- The Knight boiler is equipped for operation up to 2000 feet. For operation at elevations above 2000 feet, the appliance output ratings shall be reduced at a rate of 4% for each 1000 feet above sea level. However, operation of the Knight boiler between 2000 - 4000 feet elevation requires no field adjustments. For operation above 4000 feet elevation, consult the manufacturer.

**WARNING** DO NOT install high altitude models below 4000 feet.

- Combustion and Thermal Efficiency based on I=B=R testing and rating procedure BTS-2000.
- Lochinvar's Low Temperature Efficiency is based on I=B=R test method BTS-2000, using a boiler return water temperature of 90°F, with boiler outlet water temperature of 110°F. This rating was conducted by Lochinvar.
- Ratings have been confirmed by the Hydronics Institute, Division of GAMA.

# 1 Determine boiler location

## Installation must comply with:

- Local, state, provincial, and national codes, laws, regulations, and ordinances.
- National Fuel Gas Code, ANSI Z223.1 – latest edition.
- Standard for Controls and Safety Devices for Automatically Fired Boilers, ANSI/ASME CSD-1, when required.
- National Electrical Code.
- For Canada only: B149.1 or B149.2 Installation Code, CSA C22.1 Canadian Electrical Code Part 1 and any local codes.

### NOTICE

The Knight boiler gas manifold and controls met safe lighting and other performance criteria when the boiler underwent tests specified in ANSI Z21.13 – latest edition.

## Before locating the boiler, check:

1. Check for nearby connection to:
  - System water piping
  - Venting connections
  - Gas supply piping
  - Electrical power
2. Locate the appliance so that if water connections should leak, water damage will not occur. When such locations cannot be avoided, it is recommended that a suitable drain pan, adequately drained, be installed under the appliance. The pan must not restrict combustion air flow. Under no circumstances is the manufacturer to be held responsible for water damage in connection with this appliance, or any of its components.
3. Check area around the boiler. Remove any combustible materials, gasoline and other flammable liquids.

### WARNING

Failure to keep boiler area clear and free of combustible materials, gasoline, and other flammable liquids and vapors can result in severe personal injury, death, or substantial property damage.

4. The Knight boiler must be installed so that gas control system components are protected from dripping or spraying water or rain during operation or service.
5. If a new boiler will replace an existing boiler, check for and correct system problems, such as:
  - System leaks causing oxygen corrosion or heat exchanger cracks from hard water deposits.
  - Incorrectly-sized expansion tank.
  - Lack of freeze protection in boiler water causing system and boiler to freeze and leak.

### WARNING

This appliance is certified as an indoor appliance. Do not install the appliance outdoors or locate where the appliance will be exposed to freezing temperatures or to temperatures that exceed 100°F.

Failure to install the appliance indoors could result in severe personal injury, death, or substantial property damage.

### WARNING

This appliance requires a special venting system. The vent connection to the appliance must be made with the starter CPVC pipe section provided with the appliance. The field provided vent fittings must be cemented to the CPVC pipe section. Use only the vent materials, primer and cement specified in this manual to make the vent connections. Failure to follow this warning could result in fire, personal injury, or death.

## Closet installations

### WARNING

For closet installations as shown in FIG. 9, CPVC vent material must be used (at least in the closet structure). The two ventilating air openings shown in FIG. 9 are required for this arrangement. Failure to follow this warning could result in fire, personal injury, or death.

## Alcove installations

For alcove installations as shown in FIG. 10, PVC vent material can be used with the required clearances and an open front.

## Provide clearances:

### Clearances from combustible materials

1. Hot water pipes—at least 1" from combustible materials.
2. Vent pipe – at least 1" from combustible materials.
3. See FIG.'s 9 and 10 on page 9 for other clearance minimums.

### Clearances for service access

1. See FIG.'s 9 and 10 on page 9 for recommended service clearances. If you do not provide the minimum clearances shown, it may not be possible to service the boiler without removing it from the space.



# 1 Determine boiler location *(continued)*

**Figure 9** Closet Installation - Minimum Required Clearances

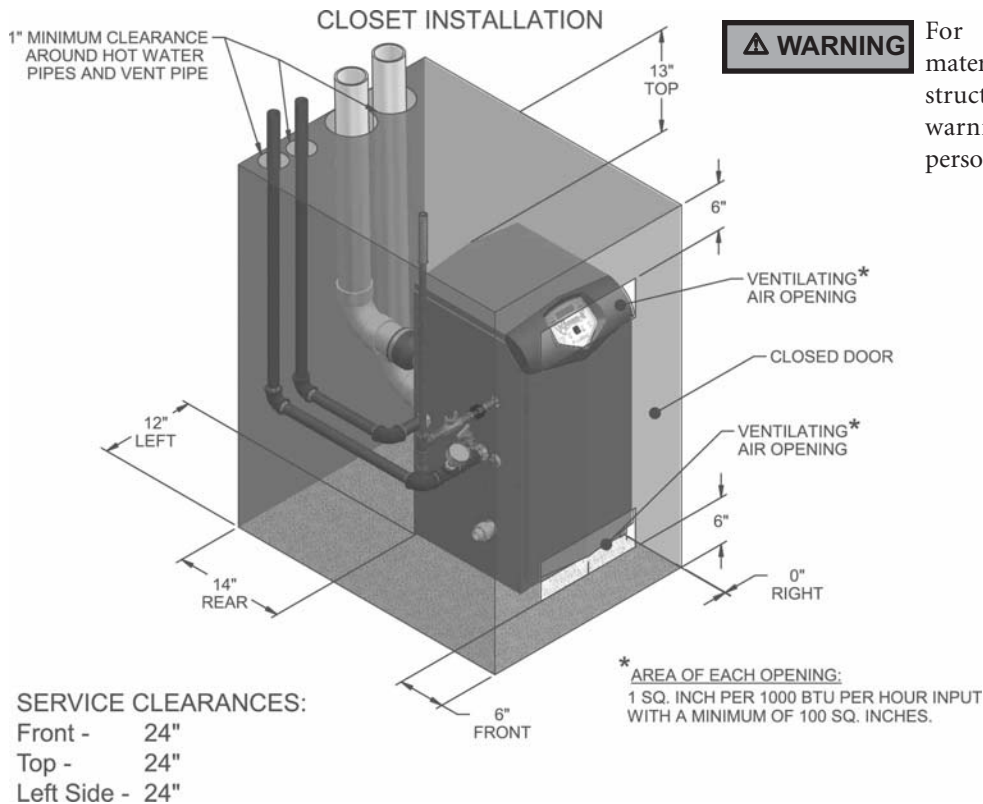

**Figure 10** Alcove Installation - Minimum Required Clearances

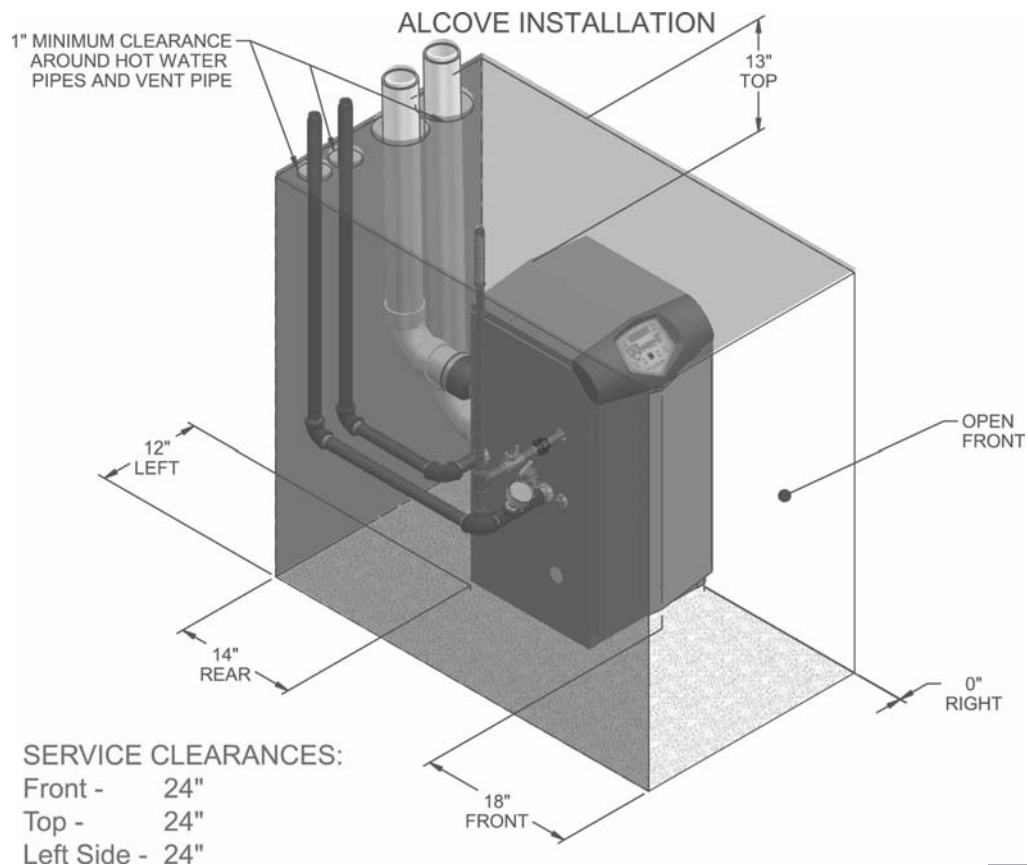

# 1 Determine boiler location

## Provide air openings to room:

### Knight boiler alone in boiler room

1. No air ventilation openings into the boiler room are needed when clearances around the Knight boiler are at least equal to the SERVICE clearances shown in FIG.s 9 and 10. For spaces that do NOT supply this clearance, provide two openings as shown in FIG. 9. Each opening must provide one square inch free area per 1,000 Btu/hr of boiler input.

### Knight boiler in same space with other gas or oil-fired appliances

1. Follow the National Fuel Gas Code (U.S.) or CSA B149.1 and B149.2 (Canada) to size/verify size of the combustion/ventilation air openings into the space.

**⚠ WARNING** The space must be provided with combustion/ventilation air openings correctly sized for all other appliances located in the same space as the Knight boiler.

Do not install the boiler in an attic.

Failure to comply with the above warnings could result in severe personal injury, death, or substantial property damage.

2. Size openings only on the basis of the other appliances in the space. No additional air opening free area is needed for the Knight boiler because it takes its combustion air from outside (direct vent installation).

## Flooring and foundation

### Flooring

The Knight boiler is approved for installation on combustible flooring, but must never be installed on carpeting.

**⚠ WARNING** Do not install the boiler on carpeting even if foundation is used. Fire can result, causing severe personal injury, death, or substantial property damage.

If flooding is possible, elevate the boiler sufficiently to prevent water from reaching the boiler.

## Residential garage installation

### Precautions

Take the following special precautions when installing the boiler in a residential garage. If the boiler is located in a residential garage, per ANSI Z223.1, paragraph 5.1.9:

- Mount the boiler with a minimum of 18 inches above the floor of the garage to the bottom of the boiler to ensure the burner and ignition devices will be no less than 18 inches above the floor.
- Locate or protect the boiler so it cannot be damaged by a moving vehicle.

### Vent and air piping

The Knight boiler requires a special vent system, designed for pressurized venting.

You must also install air piping from outside to the boiler air intake adapter. The resultant installation is direct vent (sealed combustion). Note prevention of combustion air contamination below when considering vent/air termination.

Vent and air must terminate near one another and may be vented vertically through the roof or out a side wall. You may use any of the vent/air piping methods covered in this manual. Do not attempt to install the Knight boiler using any other means.

Be sure to locate the boiler such that the vent and air piping can be routed through the building and properly terminated. The vent/air piping lengths, routing and termination method must all comply with the methods and limits given in this manual.

### Prevent combustion air contamination

Install air inlet piping for the Knight boiler as described in this manual. Do not terminate vent/air in locations that can allow contamination of combustion air. Refer to Table 1, page 11 for products and areas which may cause contaminated combustion air.

**⚠ WARNING** You must pipe combustion air to the boiler air intake. Ensure that the combustion air will not contain any of the contaminants in Table 1, page 11. Contaminated combustion air will damage the boiler, resulting in possible severe personal injury, death or substantial property damage. Do not pipe combustion air near a swimming pool, for example. Also, avoid areas subject to exhaust fumes from laundry facilities. These areas will always contain contaminants.

# 1 Determine boiler location *(continued)*

**Table 1 Corrosive Contaminants and Sources**

Products to avoid:
Spray cans containing chloro/fluorocarbons
Permanent wave solutions
Chlorinated waxes/cleaners
Chlorine-based swimming pool chemicals
Calcium chloride used for thawing
Sodium chloride used for water softening
Refrigerant leaks
Paint or varnish removers
Hydrochloric acid/muriatic acid
Cements and glues
Antistatic fabric softeners used in clothes dryers
Chlorine-type bleaches, detergents, and cleaning solvents found in household laundry rooms
Adhesives used to fasten building products and other similar products
Areas likely to have contaminants
Dry cleaning/laundry areas and establishments
Swimming pools
Metal fabrication plants
Beauty shops
Refrigeration repair shops
Photo processing plants
Auto body shops
Plastic manufacturing plants
Furniture refinishing areas and establishments
New building construction
Remodeling areas
Garages with workshops

## When removing a boiler from existing common vent system:

### DANGER

Do not install the Knight boiler into a common vent with any other appliance. This will cause flue gas spillage or appliance malfunction, resulting in possible severe personal injury, death, or substantial property damage.

### WARNING

Failure to follow all instructions can result in flue gas spillage and carbon monoxide emissions, causing severe personal injury or death.

At the time of removal of an existing boiler, the following steps shall be followed with each appliance remaining connected to the common venting system placed in operation, while the other appliances remaining connected to the common venting system are not in operation.

- a. Seal any unused openings in the common venting system.
- b. Visually inspect the venting system for proper size and horizontal pitch and determine there is no blockage or restriction, leakage, corrosion, or other deficiencies, which could cause an unsafe condition.
- c. Test vent system – Insofar as is practical, close all building doors and windows and all doors between the space in which the appliances remaining connected to the common venting system are located and other spaces of the building. Turn on clothes dryers and any appliance not connected to the common venting system. Turn on any exhaust fans, such as range hoods and bathroom exhausts, so they will operate at maximum speed. Do not operate a summer exhaust fan. Close fireplace dampers.
- d. Place in operation the appliance being inspected. Follow the lighting instructions. Adjust thermostat so appliance will operate continuously.
- e. Test for spillage at the draft hood relief opening after 5 minutes of main burner operation. Use the flame of a match or candle, or smoke from a cigarette, cigar, or pipe.
- f. After it has been determined that each appliance remaining connected to the common venting system properly vents when tested as outlined herein, return doors, windows, exhaust fans, fireplace dampers, and any other gas-burning appliance to their previous conditions of use.
- g. Any improper operation of the common venting system should be corrected so the installation conforms with the National Fuel Gas Code, ANSI Z223.1/NFPA 54 and/or CAN/CSA B149.1, Natural Gas and Propane Installation Code. When resizing any portion of the common venting system, the common venting system should be resized to approach the minimum size as determined using the appropriate tables in Part 11 of the National Fuel Gas Code, ANSI Z223.1/NFPA and/or CAN/CSA B149.1, Natural Gas and Propane Installation Code.

## 2 Prepare boiler

### Remove boiler from wood pallet

1. After removing the outer shipping carton from the boiler, remove the parts box.
2. Remove the front door to access the lag bolts in front of the unit (FIG. 11).
3. To remove the boiler from the pallet (after removing the front door):
  - a. Remove the two lag bolts from the wood pallet inside the boiler (FIG. 11).
  - b. Detach the boiler from the lag bolts in the rear of the unit, see FIG. 11.

#### NOTICE

Do not drop the boiler or bump the jacket on the floor or pallet. Damage to the boiler can result.

Figure 11 Boiler Mounted on Shipping Pallet

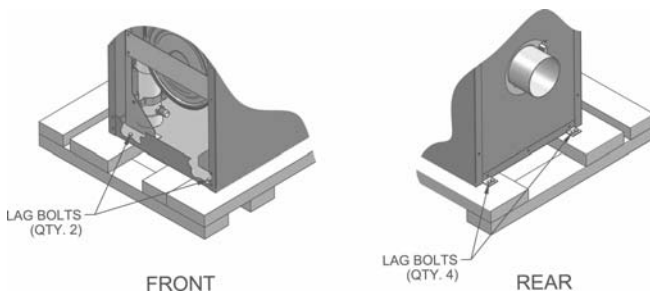

### Gas conversions

#### ⚠ WARNING

For a boiler already installed, you must turn off gas supply, turn off power and allow boiler to cool before proceeding. You must also completely test the boiler after conversion to verify performance as described under Start-up, Section 10 of this manual.

You must install the propane orifice to fire the Knight boiler on propane. Verify when installing that the orifice size marking matches boiler size (Models 80 – 399, Table 2). Failure to comply could result in severe personal injury, death, or substantial property damage.

Table 2 LP Conversion Table

LP Conversion Table	
Model	LP Orifice Stamping
80	80
105	105
150	150
210	210
285	285
399	7.2

### Models 80 - 285

1. Remove the top and front access covers from the unit (no tools required for removal).
2. Remove the three star-drive screws securing the gas valve to the venturi (FIG. 12).
3. Locate the propane orifice disk from the conversion kit bag. Verify that the stamping on the orifice disk matches the boiler size (80 – 285) (see Table 2 above).

Place the orifice into the black rubber grommet in the side of the gas valve and secure in the valve (FIG. 12).

4. Reposition the gas valve against the venturi and replace the star-drive screws (FIG. 12) securing the valve to the venturi.
5. After installation is complete, attach the propane conversion label (in the conversion kit bag) next to the boiler rating plate. Attach the LP caution label (in the conversion kit bag) to the left side of the unit in the lower left corner.
6. Replace the top and front access covers.

Figure 12 Installing Propane Orifice - Models 80 - 285

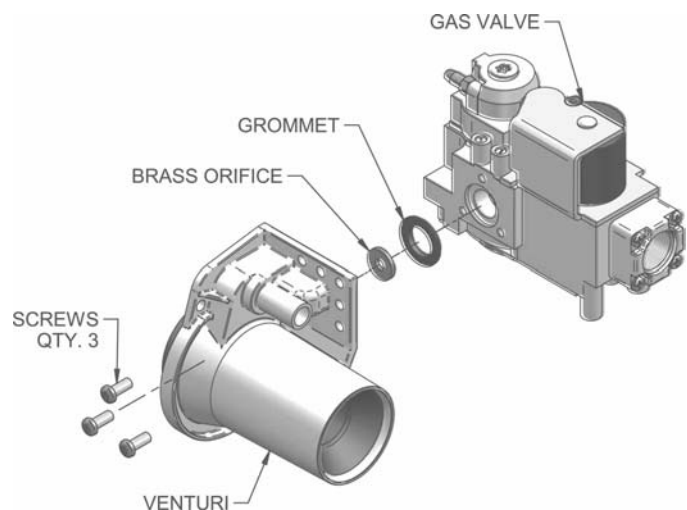

## 2 Prepare boiler *(continued)*

### Model 399

1. Remove the top and front access covers from the unit (no tools required for removal).
2. Remove the three screws securing the venturi to the blower.  
**Note:** When separating the venturi from the blower, take care not to damage the O-ring inside the blower (FIG. 13).
3. Remove the four star-drive screws securing the gas valve to the venturi (FIG. 13).
4. Locate the propane orifice disk from the conversion kit bag. Verify that the stamping on the orifice disk matches the boiler size (399) (see Table 2 on page 12).
5. Remove the existing orifice from the O-ring in the side of the gas valve and replace it with the orifice from the kit. Position and secure the orifice in the valve as shown in FIG. 13.
6. Reposition the gas valve against the venturi and replace the star-drive screws (FIG. 13) securing the valve to the venturi.
7. Inspect the O-ring inside the blower. Handle the O-ring with care, do not damage. Reposition the venturi against the blower and replace the screws securing the venturi to the blower (FIG. 13).
8. After installation is complete, attach the propane conversion label (in the conversion kit bag) next to the boiler rating plate. Attach the LP caution label (in the conversion kit bag) to the left side of the unit in the lower left corner.
9. Replace the top and front access covers.

**⚠ DANGER** Knight 399: Inspect the O-ring when the blower is disassembled. The O-ring must be in good condition and must be installed. Failure to comply will cause a gas leak, resulting in severe personal injury or death.

**Figure 13** Installing Propane Orifice - Model 399

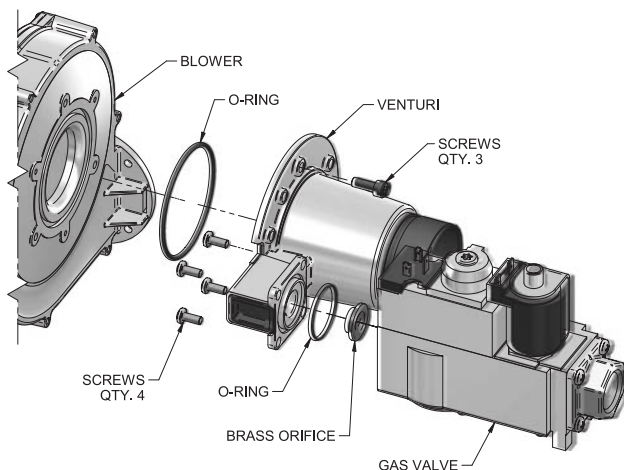

### Model 500

1. Remove the top access cover from the unit (no tools required for removal).
2. Remove the cover on top of the gas valve (FIG. 14).
3. Turn the adjustment screw on top of the gas valve one revolution counterclockwise (see FIG. 14).
4. Use a combustion analyzer to verify CO<sub>2</sub> is within the range of 9.6 – 10.2%. If not, adjust the screw clockwise to raise CO<sub>2</sub> and counterclockwise to lower CO<sub>2</sub> (FIG. 14).
5. After adjustment is complete, attach the propane conversion label (in the conversion kit bag) next to the boiler rating plate. Attach the LP caution label (in the conversion kit bag) to the left side of the unit in the lower left corner.
6. Replace the gas valve cover along with the top access cover.

**Figure 14** Gas Valve Adjustment - Model 500

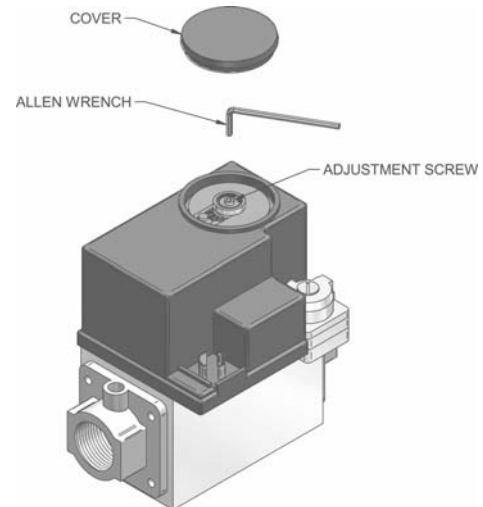

### Leveling the boiler

1. Set the boiler in place and check level.
  - a) Adjust legs if necessary to level boiler, see FIG. 15 below.

**Figure 15** Leveling Legs on the Boiler

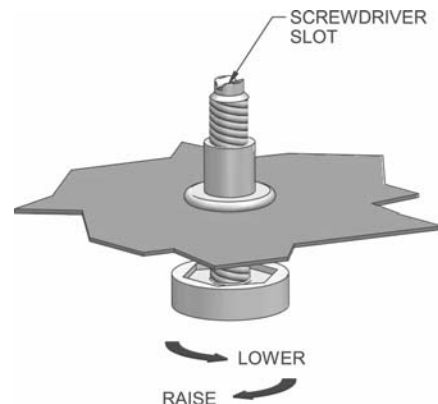

### 3 General venting

#### Direct venting options

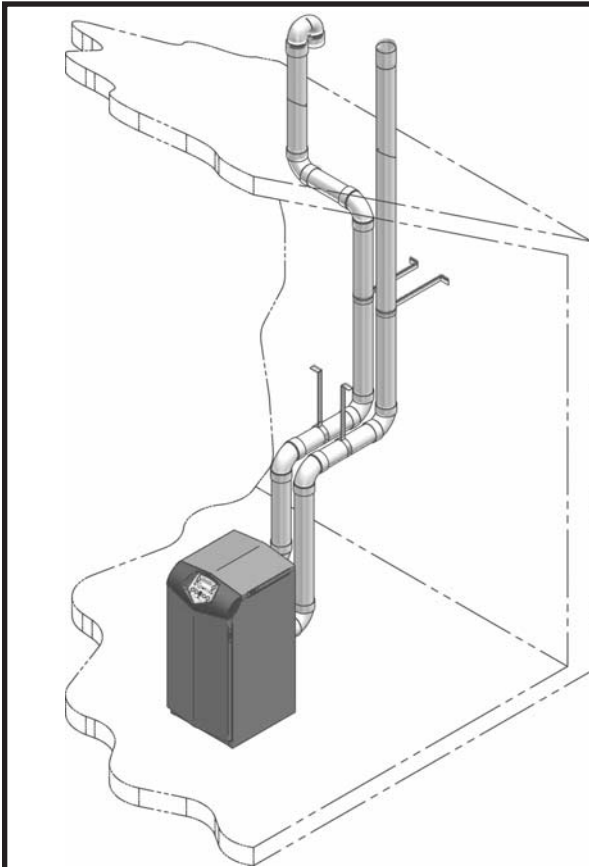

**Figure 16** Two-Pipe Vertical Termination - See page 24 for more details

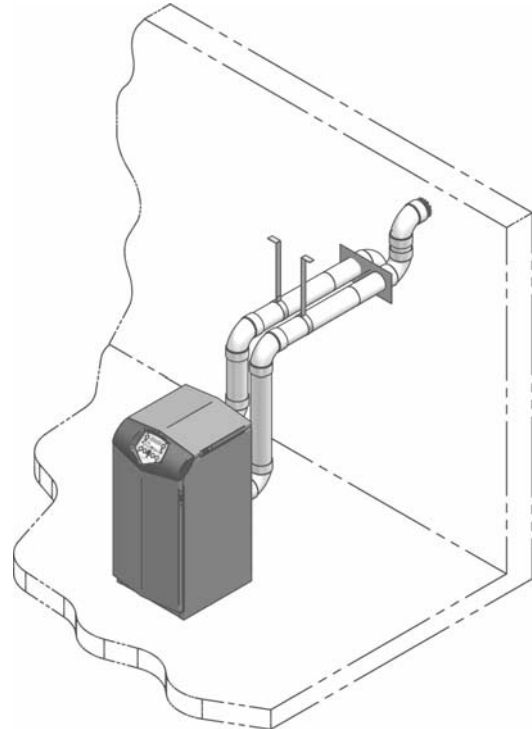

**Figure 17** Two-Pipe Sidewall Termination - See page 18 for more details

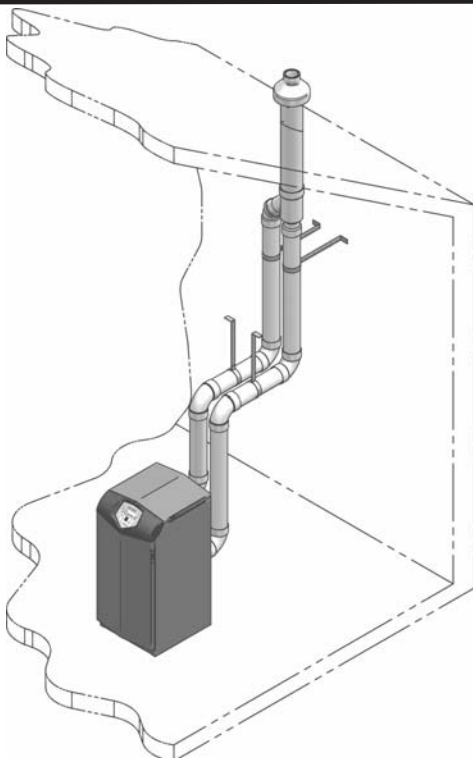

**Figure 18** Concentric Vertical Termination - See page 26 for more details

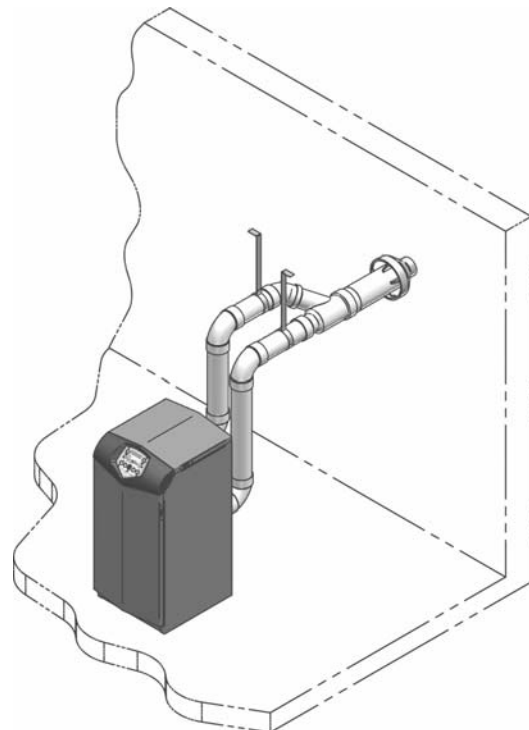

**Figure 19** Concentric Sidewall Termination - See page 21 for more details

### 3 General venting *(continued)*

#### Install vent and combustion air piping

**⚠ DANGER** The Knight boiler must be vented and supplied with combustion and ventilation air as described in this section. Ensure the vent and air piping and the combustion air supply comply with these instructions regarding vent system, air system, and combustion air quality. See also Section 1 of this manual.

Inspect finished vent and air piping thoroughly to ensure all are airtight and comply with the instructions provided and with all requirements of applicable codes.

Failure to provide a properly installed vent and air system will cause severe personal injury or death.

#### Vent and air piping materials

**⚠ WARNING** Use only the materials listed in Table 3 below for vent, air pipe, and fittings. Failure to comply could result in severe personal injury, death, or substantial property damage.

**NOTICE** Installation must comply with local requirements and with the National Fuel Gas Code, ANSI Z223.1 for U.S. installations or CSA B149.1 or B149.2 for Canadian installations.

**⚠ WARNING** For closet installations, CPVC material **MUST BE** used in a closet structure. Failure to follow this warning could result in fire, personal injury, or death.

**NOTICE** All vent pipes must be glued, properly supported, and the exhaust must be pitched a minimum of a 1/4 inch per foot back to the boiler (to allow drainage of condensate).

**⚠ WARNING** This appliance requires a special venting system. The vent connection to the appliance must be made with the starter CPVC pipe section provided with the appliance. The field provided vent fittings must be cemented to the CPVC pipe section using an “All Purpose Cement” suitable for PVC and CPVC pipe. Use only the vent materials, primer, and cement specified in this manual to make the vent connections. Failure to follow this warning could result in fire, personal injury, or death.

**Table 3** Vent, Air Pipe, and Fittings

All combustion air and vent pipe materials and fittings must comply with the following:			
Item	Material	Standards for installation in:	
		United States	Canada
Vent or air pipe and fittings	PVC schedule 40	ANSI/ASTM D1785	CSA or ULC certified only
	PVC-DWV	ANSI/ASTM D2665	
	CPVC schedule 40	ANSI/ASTM F441	
	ABS-DWV schedule 40	ANSI/ASTM D2661	
Pipe cement/primer	PVC	ANSI/ASTM D2564	
	CPVC	ANSI/ASTM F493	
	ABS	ANSI/ASTM D2235	

**NOTICE: DO NOT USE CELLULAR (FOAM) CORE PIPE**

### 3 General venting

#### NOTICE

Combustion air piping to the outside **MUST BE** used. Use of combustion air from the room via louvers, plenums, or any other device is not authorized.

#### Air intake/vent connections

1. **Combustion Air Intake Connector** (FIG.'s 20 and 21) - Used to provide combustion air directly to the unit from outdoors. A fitting is provided on the unit for final connection. Combustion air piping must be supported per guidelines listed in the National Mechanical Code, Section 305, Table 305.4 or as local codes dictate.
2. **Vent Connector** (FIG.'s 20 and 21) - Used to provide a passageway for conveying combustion gases to the outside. A transition fitting is provided on the unit for final connection. Vent piping must be supported per the National Building Code, Section 305, Table 305.4 or as local codes dictate.

**Figure 20** Near Boiler Venting Models 80 - 210

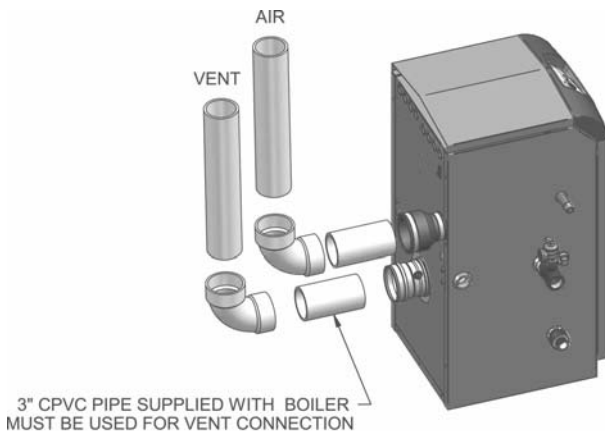

NOTE: CPVC VENT PIPE AND VENT FITTINGS MUST BE USED IN CLOSET INSTALLATIONS. FOR ALCOVE INSTALLATIONS, EITHER PVC OR CPVC PIPE AND FITTINGS MAY BE USED.

**Figure 21** Near Boiler Venting Models 285 - 500

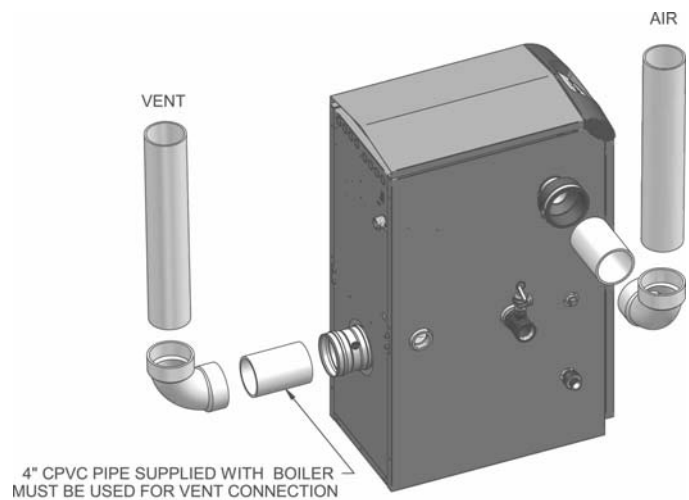

NOTE: CPVC VENT PIPE AND VENT FITTINGS MUST BE USED IN CLOSET INSTALLATIONS. FOR ALCOVE INSTALLATIONS, EITHER PVC OR CPVC PIPE AND FITTINGS MAY BE USED.

The Knight boiler uses model specific combustion air intake and vent piping sizes as detailed in Table 4 below.

**Table 4** Air Intake/Vent Piping Sizes

Model	Air Intake	Vent
80 - 210	3"	3"
285 - 500	4"	4"

#### NOTICE

Increasing or decreasing combustion air or vent piping is not authorized.

#### Maximum allowable combustion air and vent piping lengths are as follows:

**Combustion Air** = 100 equivalent feet

**Vent** = 100 equivalent feet

When determining equivalent combustion air and vent length, add 5 feet for each 90° elbow, 3 feet for each 45° elbow, and 3 feet for the concentric vent kit, see example below.

**EXAMPLE:** 20 feet of PVC pipe + (4) 90° elbows + (2) 45° elbows + (1) concentric vent kit = 49 equivalent feet of piping.



## 3 General venting *(continued)*

### Removing from existing vent

Follow the instructions in Section 1, page 11 of this manual when removing a boiler from an existing vent system.

### Vent and air piping

#### Vent and air system:

#### NOTICE

Installation must comply with local requirements and with the National Fuel Gas Code, ANSI Z223.1 for U.S. installations or CSA B149.1 or B149.2 for Canadian installations.

You must also install air piping from outside to the boiler air intake adapter. The resultant installation is direct vent (sealed combustion).

You may use any of the vent/air piping methods covered in this manual. Do not attempt to install the Knight boiler using any other means.

#### ⚠ WARNING

DO NOT mix components from different systems. The vent system could fail, causing leakage of flue products into the living space. Use only PVC, CPVC, or ABS pipe and fittings, with primer and cement specifically designed for the material used.

### Vent, air piping and termination:

The Knight boiler vent and air piping can be installed through the roof or through a sidewall. Follow the procedures in this manual for the method chosen. Refer to the information in this manual to determine acceptable vent and air piping length.

### Air contamination

Pool and laundry products and common household and hobby products often contain fluorine or chlorine compounds. When these chemicals pass through the boiler, they can form strong acids. The acid can eat through the boiler wall, causing serious damage and presenting a possible threat of flue gas spillage or boiler water leakage into the building.

Please read the information given in Table 1, page 11, listing contaminants and areas likely to contain them. If contaminating chemicals will be present near the location of the boiler combustion air inlet, have your installer pipe the boiler combustion air and vent to another location, per this manual.

#### ⚠ WARNING

If the boiler combustion air inlet is located in a laundry room or pool facility, for example, these areas will always contain hazardous contaminants.

#### ⚠ WARNING

To prevent the potential of severe personal injury or death, check for areas and products listed in Table 1, page 11 before installing the boiler or air inlet piping.

If contaminants are found, you **MUST**:

- Remove products permanently.
- OR—
- Relocate air inlet and vent terminations to other areas.

## 4 Sidewall direct venting

### Vent/air termination – sidewall

**⚠ WARNING** Follow instructions below when determining vent location to avoid possibility of severe personal injury, death, or substantial property damage.

**⚠ WARNING** A gas vent extending through an exterior wall shall not terminate adjacent to a wall or below building extensions such as eaves, parapets, balconies, or decks. Failure to comply could result in severe personal injury, death, or substantial property damage.

**⚠ WARNING** Do not connect any other appliance to the vent pipe or multiple boilers to a common vent pipe. Failure to comply could result in severe personal injury, death, or substantial property damage.

**NOTICE** Installation must comply with local requirements and with the National Fuel Gas Code, ANSI Z223.1 for U.S. installations or CSA B149.1 or B149.2 for Canadian installations.

### Determine location

Locate the vent/air terminations using the following guidelines:

1. The total length of piping for vent or air must not exceed the limits given in the General Venting Section on page 16 of this manual.
2. The air piping must terminate in a down-turned elbow as shown in FIG. 22. This arrangement avoids recirculation of flue products into the combustion air stream.
3. The vent piping must terminate in an elbow pointed outward or away from the air inlet, as shown in FIG. 22.

**⚠ WARNING** Do not exceed the maximum lengths of the outside vent piping shown in FIG. 22. Excessive length exposed to the outside could cause freezing of condensate in the vent pipe, resulting in potential boiler shutdown.

4. You must consider the surroundings when terminating the vent and air:
  - a. Position the vent termination where vapors will not damage nearby shrubs, plants or air conditioning equipment or be objectionable.
  - b. The flue products will form a noticeable plume as they condense in cold air. Avoid areas where the plume could obstruct window views.

- c. Prevailing winds could cause freezing of condensate and water/ice buildup where flue products impinge on building surfaces or plants.
- d. Avoid possibility of accidental contact of flue products with people or pets.
- e. Do not locate the terminations where wind eddies could affect performance or cause recirculation, such as inside building corners, near adjacent buildings or surfaces, window wells, stairwells, alcoves, courtyards, or other recessed areas.

**Figure 22** Sidewall Termination of Air and Vent

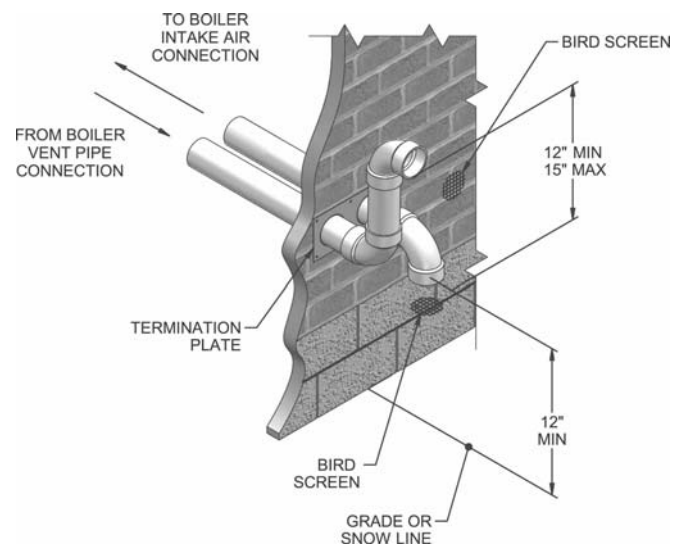

**Figure 23** Alternate Sidewall Termination of Air and Vent if Space Allows

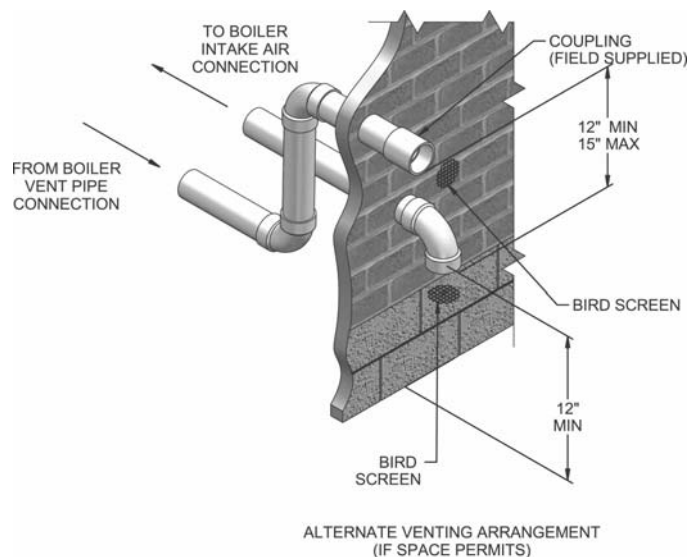

## 4 Sidewall direct venting *(continued)*

### Vent/air termination – sidewall

- f. Do not terminate above any door or window. Condensate can freeze, causing ice formations.
  - g. Locate or guard vent to prevent condensate damage to exterior finishes.
5. Maintain clearances as shown in FIG.'s 22 - 25, pages 18 and 19. Also maintain the following:
    - a. Vent must terminate:
      - At least 6 feet from adjacent walls.
      - No closer than 5 feet below roof overhang.
      - At least 7 feet above any public walkway.
      - At least 3 feet above any forced air intake within 10 feet.
      - No closer than 12 inches below or horizontally from any door or window or any other gravity air inlet.
    - b. Air inlet must terminate at least 12 inches above grade or snow line; at least 12 inches below the vent termination; and the vent pipe must not extend more than 24 inches vertically outside the building as shown in FIG. 22.
    - c. Do not terminate closer than 4 feet horizontally from any electric meter, gas meter, regulator, relief valve, or other equipment. Never terminate above or below any of these within 4 feet horizontally.
  6. Locate terminations so they are not likely to be damaged by foreign objects, such as stones or balls, or subject to buildup of leaves or sediment.

**Figure 24** Clearance to Gravity Air Inlets

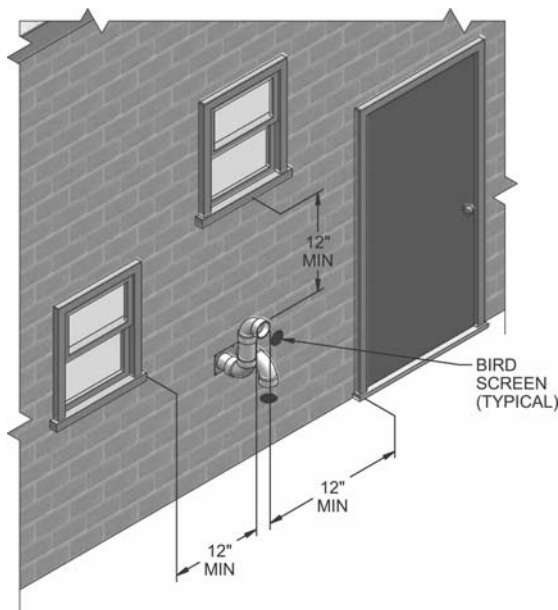

**Figure 25** Clearance to Forced Air Inlets

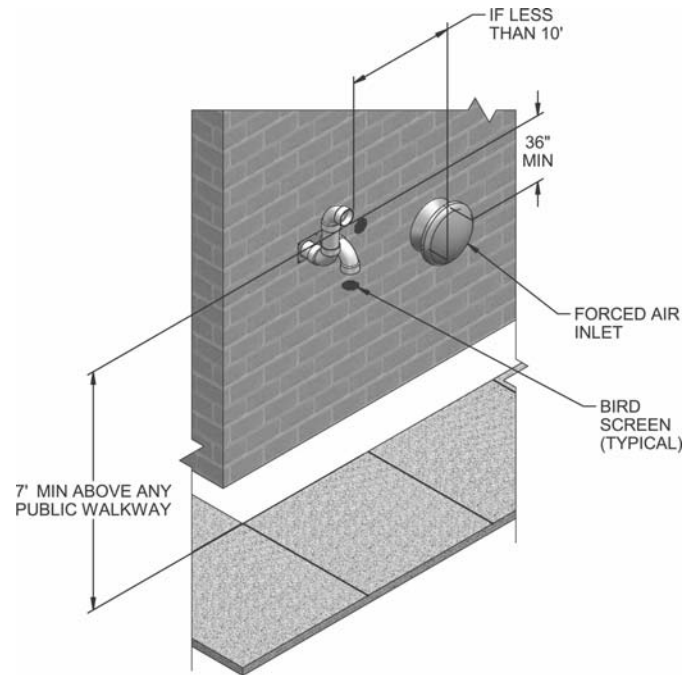

### Prepare wall penetrations

1. Air pipe penetration:
  - a. Cut a hole for the air pipe. Size the air pipe hole as close as desired to the air pipe outside diameter.
2. Vent pipe penetration:
  - a. Cut a hole for the vent pipe. For either combustible or noncombustible construction, size the vent pipe hole at least 1/2 inch larger than the vent pipe diameter:
    - 4 inch hole for 3 inch vent pipe
    - 5 inch hole for 4 inch vent pipe
  - b. Insert a galvanized metal thimble in the vent pipe hole as shown in FIG. 26.
3. Use a sidewall termination plate as a template for correct location of hole centers.
4. Follow all local codes for isolation of vent pipe when passing through floors or walls.
5. Seal exterior openings thoroughly with exterior caulk.

## 4 Sidewall direct venting

### Vent/air termination – sidewall

Figure 26 Sidewall Termination Assembly

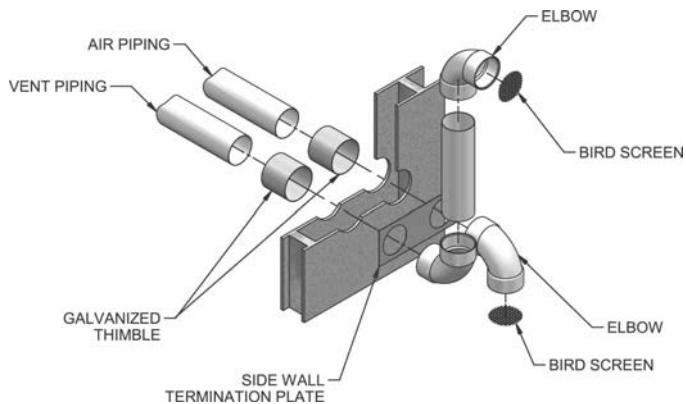

### Termination and fittings

1. Prepare the vent termination elbow and the air termination elbow (FIG. 26) by inserting the bird screens provided with the boiler. Bird screens are provided for either 3 inches (Knight 80 – 105 – 150 and 210) or 4 inches (Knight 285 – 399 and 500) fittings.
2. When completed, the air termination coupling must be oriented at least 12 inches below the vent termination and at least 12 inches above grade or snow line as shown in FIG. 22, page 18.
3. Maintain the required dimensions of the finished termination piping as shown in FIG. 22, page 18.
4. Do not extend exposed vent pipe outside of building more than shown in this document. Condensate could freeze and block vent pipe.

### Multiple vent/air terminations

1. When terminating multiple Knight boilers terminate each vent/air connection as described in this manual (FIG. 27).

**⚠ WARNING** All vent pipes and air inlets must terminate at the same height to avoid possibility of severe personal injury, death, or substantial property damage.

2. Place wall penetrations to obtain minimum clearance of 12 inches between vent pipe and adjacent air inlet elbow, as shown in FIG. 27 for U.S. installations. For Canadian installations, provide clearances required by CSA B149.1 or B149.2 Installation Code.
3. The air inlet of a Knight boiler is part of a direct vent connection. It is not classified as a forced air intake with regard to spacing from adjacent boiler vents.

Figure 27 Multiple Vent Terminations (must also comply with FIG. 22)

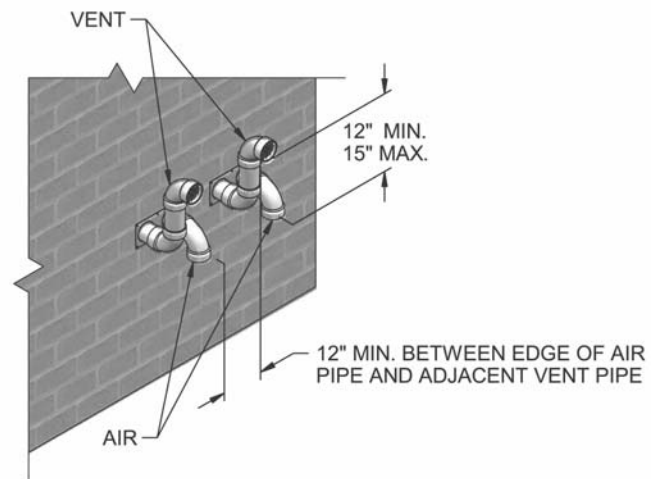

## 4 Sidewall direct venting *(continued)*

### Sidewall termination – optional concentric vent models 80 - 210 Only

#### Description and usage

Lochinvar offers an optional concentric combustion air and vent pipe termination kit (Factory Kit #CVK3003). Both combustion air and vent pipes must attach to the termination kit. The termination kit must terminate outside the structure and must be installed as shown below in FIG. 28.

The required combustion air and vent pipe fittings are listed in Table 3, on page 15 of this manual.

**Figure 28** Concentric Sidewall Termination

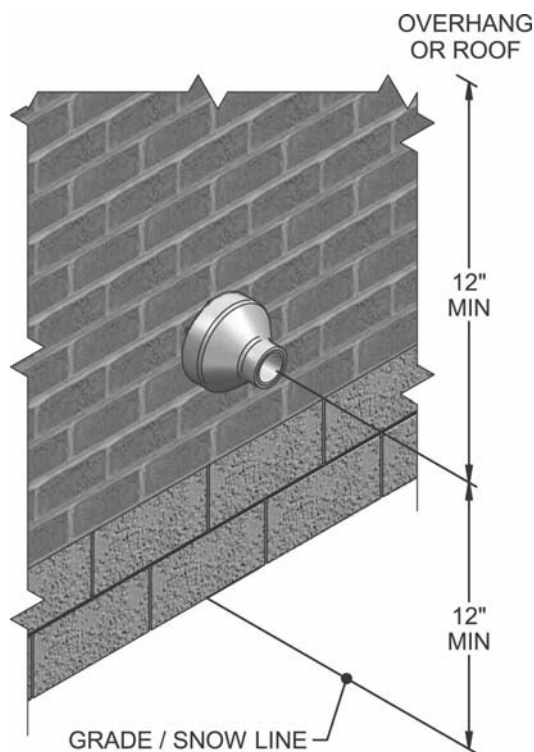

**Figure 29** Kit Contents

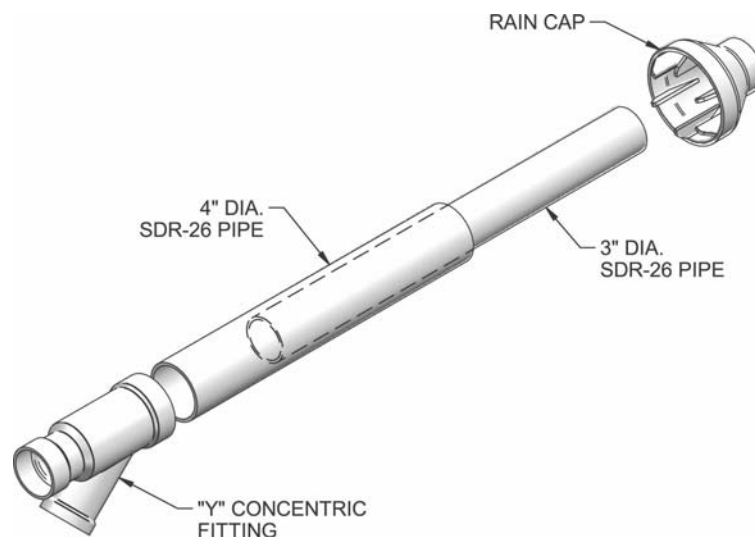

#### Sidewall termination installation

1. Determine the best location for the termination kit (see FIG. 28).
2. The total length of piping for vent or air must not exceed the limits given in the General Venting Section on page 16 of this manual.
3. You must consider the surroundings when terminating the vent and air:
  - a. Position the vent termination where vapors will not damage nearby shrubs, plants or air conditioning equipment or be objectionable.
  - b. The flue products will form a noticeable plume as they condense in cold air. Avoid areas where the plume could obstruct window views.
  - c. Prevailing winds could cause freezing of condensate and water/ice buildup where flue products impinge on building surfaces or plants.
  - d. Avoid possibility of accidental contact of flue products with people or pets.
  - f. Do not terminate above any door or window. Condensate can freeze, causing ice formations.
  - g. Locate or guard vent to prevent condensate damage to exterior finishes.
4. Cut one (1) hole (5 inch diameter) into the structure to install the termination kit.
5. Partially assemble the concentric vent termination kit. Clean and cement using the procedures found in these instructions.
  - a. Cement the Y concentric fitting to the larger kit pipe (FIG. 29).
  - b. Cement the rain cap to the smaller diameter kit pipe (FIG. 29).

## 4 Sidewall direct venting

### Sidewall termination – optional concentric vent models 80 - 210 Only

Figure 30 Concentric Vent Dimensional Drawing

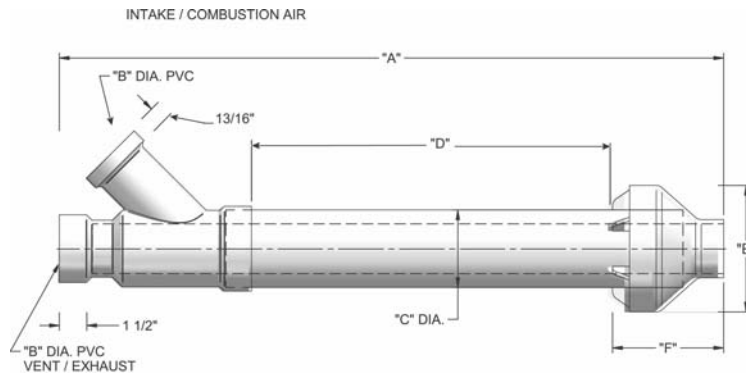

A	B	C	D	E	F
38 7/8"	3"	4 1/2"	21 1/8"	7 3/8"	6 1/2"

#### NOTICE

Instead of cementing the smaller pipe to the rain cap, a field-supplied stainless steel screw may be used to secure the two (2) components together when field disassembly is desired for cleaning (see FIG. 31).

#### WARNING

When using the alternate screw assembly method, drill a clearance hole in the rain cap and a pilot hole in the vent pipe for the screw size being used. Failure to drill adequate holes may cause cracking of PVC components, allowing combustion products to be recirculated. Failure to follow this warning could result in personal injury or death.

#### WARNING

Do not operate the appliance with the rain cap removed or recirculation of combustion products may occur. Water may also collect inside the larger combustion air pipe and flow to the burner enclosure. Failure to follow this warning could result in product damage or improper operation, personal injury, or death.

6. Install the Y concentric fitting and pipe assembly through the structure's hole.

#### NOTICE

Do not allow insulation or other materials to accumulate inside the pipe assembly when installing through the hole.

7. Install the rain cap and small diameter pipe assembly into the Y concentric fitting and large pipe assembly. Ensure small diameter pipe is bottomed and cemented in the Y concentric fitting.
8. Secure the assembly to the structure as shown in FIG. 32 using field-supplied metal strapping or equivalent support material.

#### NOTICE

Ensure termination location clearance dimensions are as shown in FIG. 28.

#### NOTICE

If assembly needs to be extended to allow sidewall thickness requirement, the two (2) pipes supplied in the kit may be replaced by using the same diameter, field-supplied SDR-26 PVC (D2241) pipe. Do not extend dimension D more than 60 inches (see FIG. 30).

Figure 31 Rain Cap to Vent Pipe Alternate Assembly

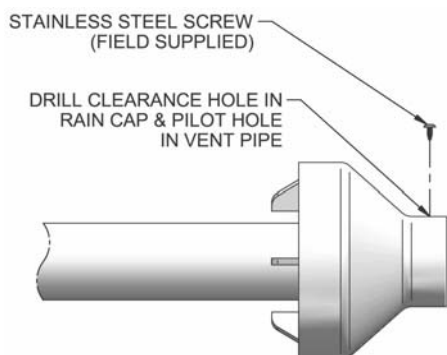

## 4 Sidewall direct venting *(continued)*

### Sidewall termination – optional concentric vent models 80 - 210 Only

Figure 32 Concentric Vent Sidewall Attachment

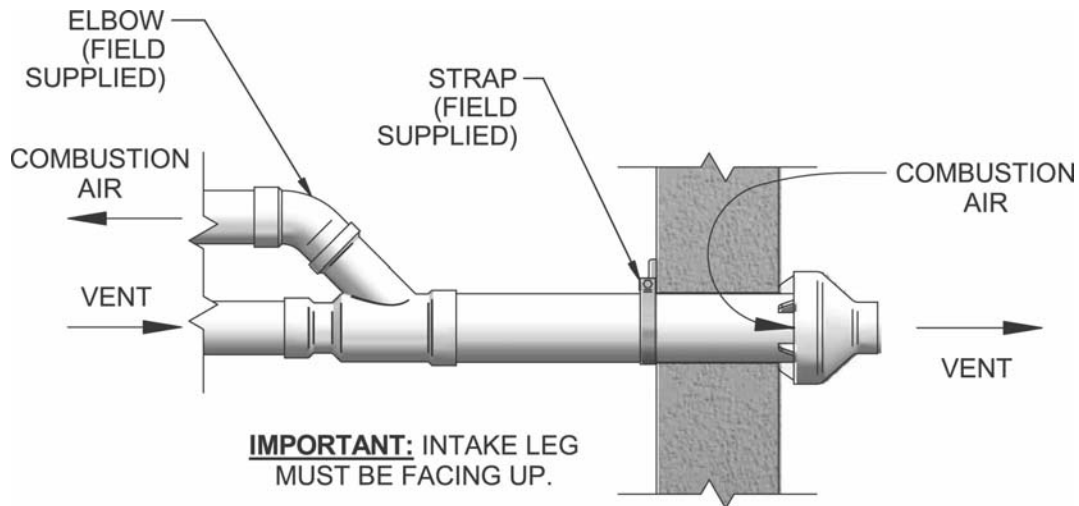

#### CAUTION

DO NOT use field-supplied couplings to extend pipes. Airflow restriction will occur and may cause intermittent operation.

9. Cement appliance combustion air and vent pipes to the concentric vent termination assembly. See FIG. 32 for proper pipe attachment.
10. Operate the appliance one (1) heat cycle to ensure combustion air and vent pipes are properly connected to the concentric vent termination connections.

#### Multiventing sidewall terminations

When two (2) or more direct vent appliances are vented near each other, each appliance must be individually vented (see FIG. 33). NEVER common vent or breach vent this appliance. When two (2) or more direct vent appliances are vented near each other, two (2) vent terminations may be installed as shown in FIG. 33, but next to the vent terminations must be at least 36 inches away from the first two (2) terminations. It is important that vent terminations be made as shown to avoid recirculation of flue gases. Dimension A in FIG. 33 represents the distance between pipes or rain shields, as touching or a 2 inch maximum separation.

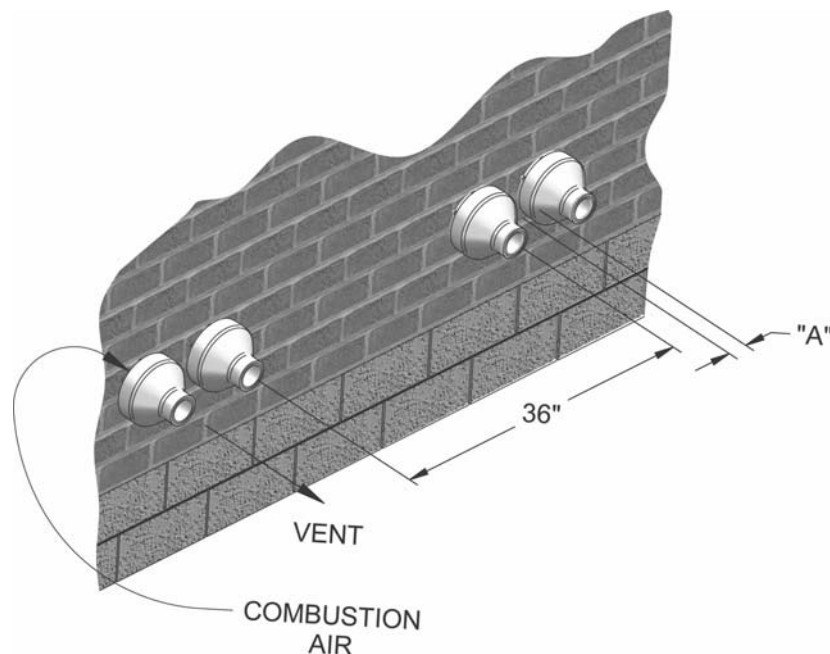

Figure 33 Concentric Vent and Combustion Air Termination  
Dimension A as Touching or 2 inches Maximum Separation - Models 80 - 210 Only

## 5 Vertical direct venting

### Vent/air termination – vertical

**⚠ WARNING** Follow instructions below when determining vent location to avoid possibility of severe personal injury, death or substantial property damage.

**⚠ WARNING** Do not connect any other appliance to the vent pipe or multiple boilers to a common vent pipe. Failure to comply could result in severe personal injury, death, or substantial property damage.

**NOTICE** Installation must comply with local requirements and with the National Fuel Gas Code, ANSI Z223.1 for U.S. installations or CSA B149.1 or B149.2 for Canadian installations.

### Determine location

Locate the vent/air terminations using the following guidelines:

1. The total length of piping for vent or air must not exceed the limits given in the General Venting Section on page 16 of this manual.
2. The air piping must terminate in a down-turned 180° return pipe no further than 2 feet from the center of the vent pipe. This placement avoids recirculation of flue products into the combustion air stream.
3. The vent piping must terminate in an up-turned coupling as shown in FIG. 34. The top of the coupling must be at least 1 foot above the air intake. The air inlet pipe and vent pipe can be located in any desired position on the roof, but must always be no further than 2 feet apart and with the vent termination at least 1 foot above the air intake.
4. You must consider the surroundings when terminating the vent and air:
  - a. Position the vent termination where vapors will not damage nearby shrubs, plants, or air conditioning equipment or be objectionable.
  - b. The flue products will form a noticeable plume as they condense in cold air. Avoid areas where the plume could obstruct window views.
  - c. Prevailing winds could cause freezing of condensate and water/ice buildup where flue products impinge on building surfaces or plants.
  - d. Avoid possibility of accidental contact of flue products with people or pets.

- e. Do not locate the terminations where wind eddies could affect performance or cause recirculation, such as inside building corners, near adjacent buildings or surfaces, window wells, stairwells, alcoves, courtyards, or other recessed areas.
- f. Do not terminate above any door or window. Condensate can freeze, causing ice formations.
- g. Locate or guard vent to prevent condensate damage to exterior finishes.

**Figure 34** Vertical Termination of Air and Vent

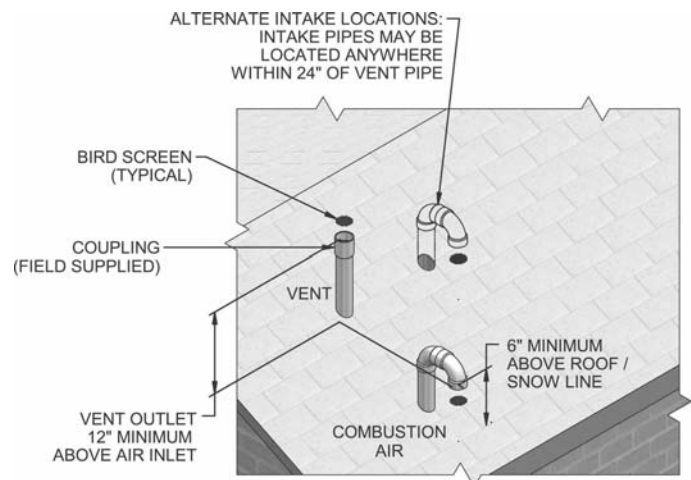

5. Maintain clearances to vent termination as given in FIG. 34:
  - a. Vent must terminate:
    - At least 6 feet from adjacent walls.
    - No closer than 5 feet below roof overhang.
    - At least 7 feet above any public walkway.
    - At least 3 feet above any forced air intake within 10 feet.
    - No closer than 12 inches below or horizontally from any door or window or any other gravity air inlet.
  - b. Air inlet must terminate at least 6 inches above the roof or snow line and at least 12 inches below the vent termination as shown in FIG. 34.
  - c. Do not terminate closer than 4 feet horizontally from any electric meter, gas meter, regulator, relief valve, or other equipment. Never terminate above or below any of these within 4 feet horizontally.
6. Locate terminations so they are not likely to be damaged by foreign objects, such as stones or balls, or subject to buildup of leaves or sediment.



## 5 Vertical direct venting *(continued)*

### Vent/air termination – vertical

#### Prepare roof penetrations

1. Air pipe penetration:
  - a. Cut a hole for the air pipe. Size the air pipe hole as close as desired to the air pipe outside diameter.
2. Vent pipe penetration:
  - a. Cut a hole for the vent pipe. For either combustible or noncombustible construction, size the vent pipe hole at least 1/2 inch larger than the vent pipe diameter:
    - 4 inch hole for 3 inch vent pipe
    - 5 inch hole for 4 inch vent pipe
  - b. Insert a galvanized metal thimble in the vent pipe hole.
3. Space the air and vent holes to provide the minimum spacing shown in FIG. 34, page 24.
4. Follow all local codes for isolation of vent pipe when passing through floors, ceilings, and roofs.
5. Provide flashing and sealing boots sized for the vent pipe and air pipe.

#### Termination and fittings

1. Prepare the vent termination coupling and the air termination elbow (FIG. 34) by inserting the bird screens provided with the boiler. Bird screens are provided for either 3" (Knight 80 – 105 – 150 and 210) or 4" (Knight 285 – 399 and 500) fittings.
2. The air piping must terminate in a down-turned 180° return bend as shown in FIG. 34. Locate the air inlet pipe no further than 2 feet from the center of the vent pipe. This placement avoids recirculation of flue products into the combustion air stream.
3. The vent piping must terminate in an up-turned coupling as shown in FIG. 34. The top of the coupling must be at least 1 foot above the air intake. The air inlet pipe and vent pipe can be located in any desired position on the roof, but must always be no further than 2 feet apart and with the vent termination at least 1 foot above the air intake.
4. Maintain the required dimensions of the finished termination piping as shown in FIG. 34.
5. Do not extend exposed vent pipe outside of building more than shown in this document. Condensate could freeze and block vent pipe.

#### Multiple vent/air terminations

1. When terminating multiple Knight boilers, terminate each vent/air connection as described in this manual (FIG. 35).

#### **⚠ WARNING**

Terminate all vent pipes at the same height and all air pipes at the same height to avoid possibility of severe personal injury, death, or substantial property damage.

2. Place roof penetrations to obtain minimum clearance of 12 inches between edge of air intake elbow and adjacent vent pipe of another boiler for U.S. installations (see FIG. 35). For Canadian installations, provide clearances required by CSA B149.1 or B149.2 Installation Code.
3. The air inlet of a Knight boiler is part of a direct vent connection. It is not classified as a forced air intake with regard to spacing from adjacent boiler vents.

**Figure 35** Vertical Terminations with Multiple Boilers

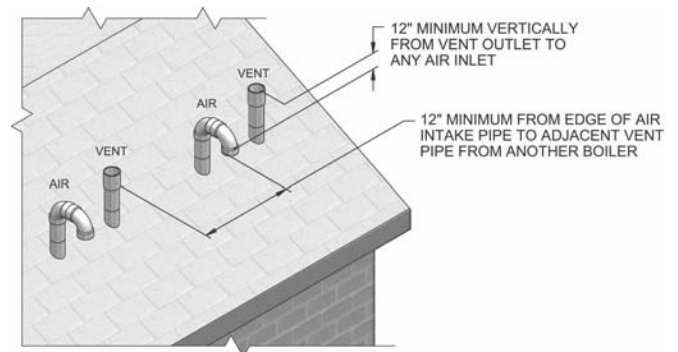

**Figure 36** Alternate Vertical Terminations with Multiple Boilers

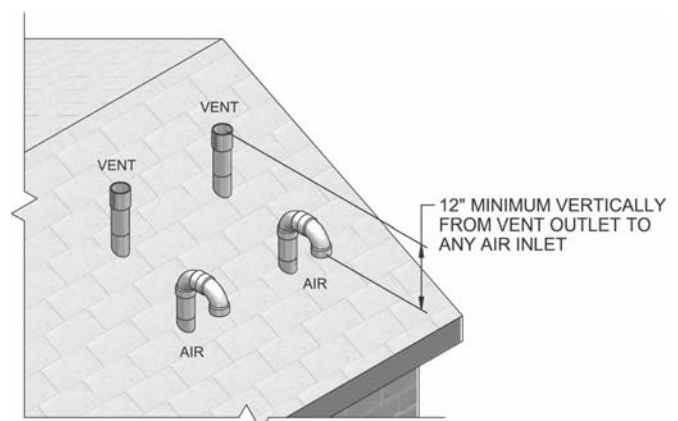

## 5 Vertical direct venting

### Vertical termination – optional concentric vent models 80 - 210 Only

#### Description and usage

Lochinvar offers an optional concentric combustion air and vent pipe termination kit. Both combustion air and vent pipes must attach to the termination kit. The termination kit must terminate outside the structure and must be installed as shown in FIG. 37.

Field supplied pipe and fittings are required to complete the installation.

The required combustion air and vent pipe fittings are listed in Table 3, on page 15 of this manual.

#### Vertical termination installation

1. Determine the best location for the termination kit (see FIG. 37).
2. The total length of piping for vent or air must not exceed the limits given in the General Venting Section on page 16 of this manual.

**Figure 37** Concentric Vertical Termination

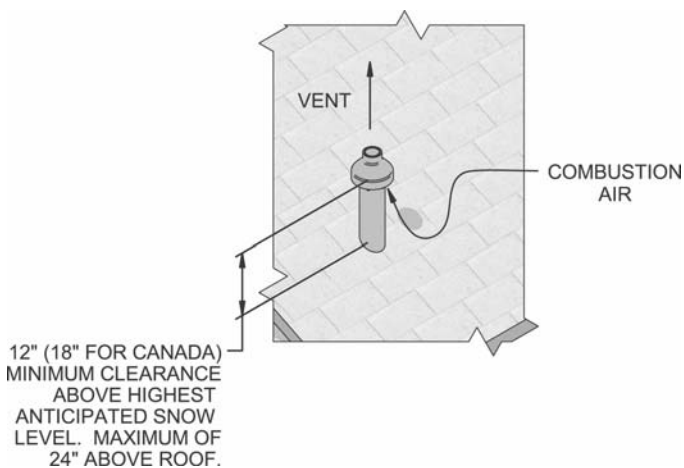

3. You must consider the surroundings when terminating the vent and air:
  - a. Position the vent termination where vapors will not damage nearby shrubs, plants, or air conditioning equipment or be objectionable.
  - b. The flue products will form a noticeable plume as they condense in cold air. Avoid areas where the plume could obstruct window views.
  - c. Prevailing winds could cause freezing of condensate and water/ice buildup where flue products impinge on building surfaces or plants.
  - d. Avoid possibility of accidental contact of flue products with people or pets.
  - e. Do not locate the terminations where wind eddies could affect performance or cause recirculation, such as inside building corners, near adjacent buildings or surfaces, window wells, stairwells, alcoves, courtyards, or other recessed areas.
  - f. Do not terminate above any door or window. Condensate can freeze, causing ice formations.
  - g. Locate or guard vent to prevent condensate damage to exterior finishes.
4. Cut one hole, (5 inch diameter) into the structure to install the termination kit.
5. Partially assemble the concentric vent termination kit. Clean and cement following the cleaning procedures in these instructions.
  - a. Cement the Y concentric fitting to the larger diameter kit pipe (see FIG. 29, page 21).
  - b. Cement rain cap to the smaller diameter kit pipe (see FIG. 29, page 21).

#### NOTICE

Instead of cementing the smaller pipe to the rain cap, a field supplied stainless steel screw may be used to secure the two (2) components together when field disassembly is desired for cleaning (see FIG. 31, page 22).

#### ⚠ WARNING

When using the alternate screw assembly method, drill a clearance hole in the rain cap and a pilot hole in the vent pipe for the screw size being used. Failure to drill adequate holes may cause cracking of PVC components, allowing combustion products to be recirculated. Failure to follow this warning could result in personal injury or death.

## 5 Vertical direct venting *(continued)*

### Vertical termination – optional concentric vent models 80 - 210 Only

**⚠ WARNING** Do not operate the appliance with the rain cap removed or recirculation of combustion products may occur. Water may also collect inside the larger combustion air pipe and flow to the burner enclosure. Failure to follow this warning could result in product damage or improper operation, personal injury, or death.

6. Install the Y concentric fitting pipe assembly through the structure's hole and field supplied roof boot/flashing.

**NOTICE** Do not allow insulation or other materials to accumulate inside the pipe assembly when installing through the hole.

7. Secure the assembly to the roof structure as shown below in FIG. 38 using field supplied metal strapping or equivalent support material.

**Figure 38** Concentric Vent Roof Installation - Models 80 - 210 Only

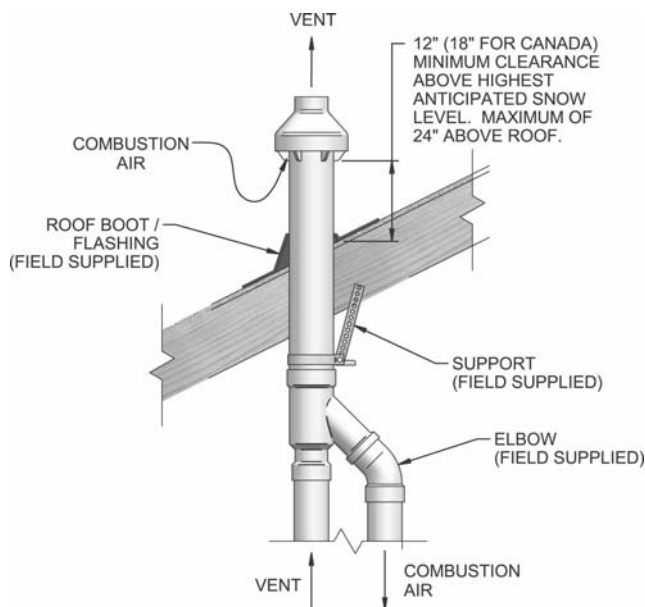

**NOTICE** Ensure termination height is above the roof surface or anticipated snow level (12 inches in U.S.A. or 18 inches in Canada) as shown in FIG. 37, page 26.

**NOTICE** If assembly is too short to meet height requirement, the two (2) pipes supplied in the kit may be replaced by using the same diameter, field supplied SDR-26 PVC (D2241) pipe. Do not extend dimension D more than 60 inches (see FIG. 30, page 22).

**CAUTION** DO NOT use field-supplied couplings to extend pipes. Airflow restriction will occur.

8. Install the rain cap and the small diameter pipe assembly into the roof penetration assembly. Ensure the small diameter pipe is cemented and bottomed in the Y concentric fitting.
9. Cement the appliance combustion air and vent pipes to the concentric vent termination assembly. See FIG. 38 for proper pipe attachment.
10. Operate the appliance through one (1) heat cycle to ensure combustion air and vent pipes are properly connected to the concentric vent termination connections.

### Multiventing vertical terminations

When two (2) or more direct vent appliances are vented near each other, each appliance must be individually vented (see FIG. 39). NEVER common vent or breach vent this appliance. When two (2) or more direct vent appliances are vented near each other, two (2) vent terminations may be installed as shown in FIG. 39, but next to the vent terminations must be at least 36 inches away from the first two (2) terminations. It is important that vent terminations be made as shown to avoid recirculation of flue gases. Dimension A in FIG. 39 represents the distance between pipes or rain shields, as touching or a 2 inch maximum separation.

**Figure 39** Concentric Vent and Combustion Air Vertical Termination (Dimension A as Touching or 2 inches Maximum Separation)

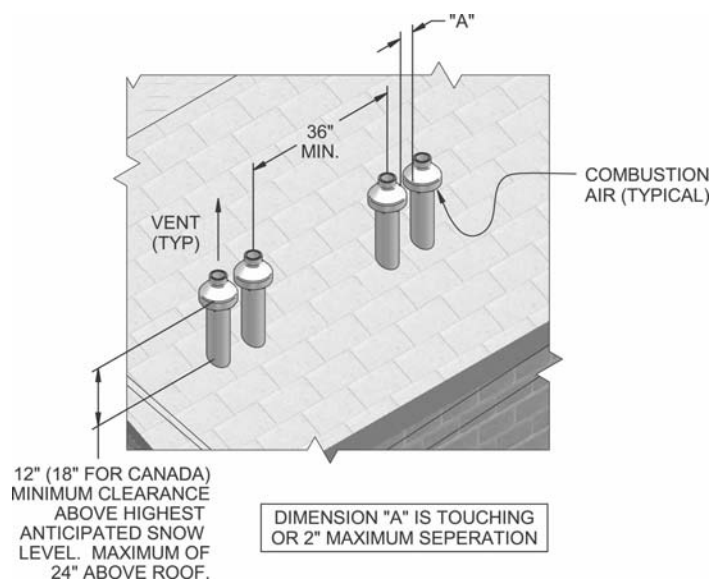

## 6 Hydronic piping

### System water piping methods

The Knight is designed to function in a closed loop pressurized system not less than 12 psi. A temperature and pressure gauge is included to monitor system pressure and outlet temperature and should be located on the boiler outlet.

It is important to note that the boiler has a minimal amount of pressure drop and must be figured in when sizing the circulators. Each boiler installation must have an air elimination device, which will remove air from the system. Install the boiler so the gas ignition system components are protected from water (dripping, spraying, etc.) during appliance operation for basic service of circulator replacement, valves, and others.

Observe a minimum of 1 inch clearance around all un-insulated hot water pipes when openings around the pipes are not protected by non-combustible materials.

### Low water cutoff device

On a boiler installed above radiation level, some states and local codes require a low water cutoff device at the time of installation.

### Chilled water system

If the boiler supplies hot water to heating coils in air handler units, flow control valves or other devices must be installed to prevent gravity circulation of heater water in the coils during the cooling cycle. A chilled water medium must be piped in parallel with the heater.

### Freeze protection

Freeze protection for new or existing systems must use glycol that is specially formulated for this purpose. This includes inhibitors, which prevent the glycol from attacking the metallic system components. Make certain to check that the system fluid is correct for the glycol concentration and inhibitor level. The system should be tested at least once a year and as recommended by the producer of the glycol solution. Allowance should be made for the expansion of the glycol solution in the system piping.

#### ⚠ WARNING

Use only inhibited propylene glycol solutions, which are specifically formulated for hydronic systems. Ethylene glycol is toxic and can attack gaskets and seals used in hydronic systems.

### General piping information

Basic steps are listed below along with illustrations on the following pages (FIG.'s 43 - 48), which will guide you through the installation of the Knight boiler (reference FIG. 40).

1. Connect the system return marked "Inlet", make sure to install with pipe sealant compound.
2. Connect the system supply marked "Outlet", make sure to install with pipe sealant compound.
3. Install purge and balance valve or shutoff valve and drain on system return to purge air out of each zone.
4. Install a backflow preventer on the cold feed make-up water line.
5. Install a pressure reducing valve on the cold feed make-up water line, (15 psi nominal). Check temperature and pressure gauge (shipped separately), which should read a minimum pressure of 12 psi.
6. Install a circulator as shown on the piping diagrams in this section. Make sure the circulator is properly sized for the system and friction loss.
7. Install an expansion tank on the system supply. Consult the tank manufacturer's instruction for specific information relating to tank installation. Size the expansion tank for the required system volume and capacity.
8. Install an air elimination device on the system supply.
9. Install a drain valve at the lowest point of the system. **Note:** The boiler cannot be drained completely of water without purging the unit with an air pressure of 15 psi.
10. This appliance is supplied with a relief valve sized in accordance with ASME Boiler and Pressure Vessel Code, Section IV ("Heating Boilers"). The safety relief valve is installed at the factory located on the left-hand side of the boiler. Pipe the discharge of the safety relief valve to prevent injury in the event of pressure relief. Pipe the discharge to a drain. Provide piping that is the same size as the safety relief valve outlet. Never block the outlet of the safety relief valve.

See the \*piping illustrations included in this section, FIG.'s 43 - 48 for suggested guidelines in piping the Knight boiler with either zone valves or circulator pumps.

#### NOTICE

\*Please note that these illustrations are meant to show system piping concept only, the installer is responsible for all equipment and detailing required by local codes.

## 6 Hydronic piping *(continued)*

### Circulator sizing

The Knight boiler heat exchanger does have a pressure drop, which must be considered in your system design. Refer to the graphs in FIG.'s 41 and 42 for pressure drop through the Knight boiler heat exchanger.

### Near boiler piping connections

Figure 40 Near Boiler Piping

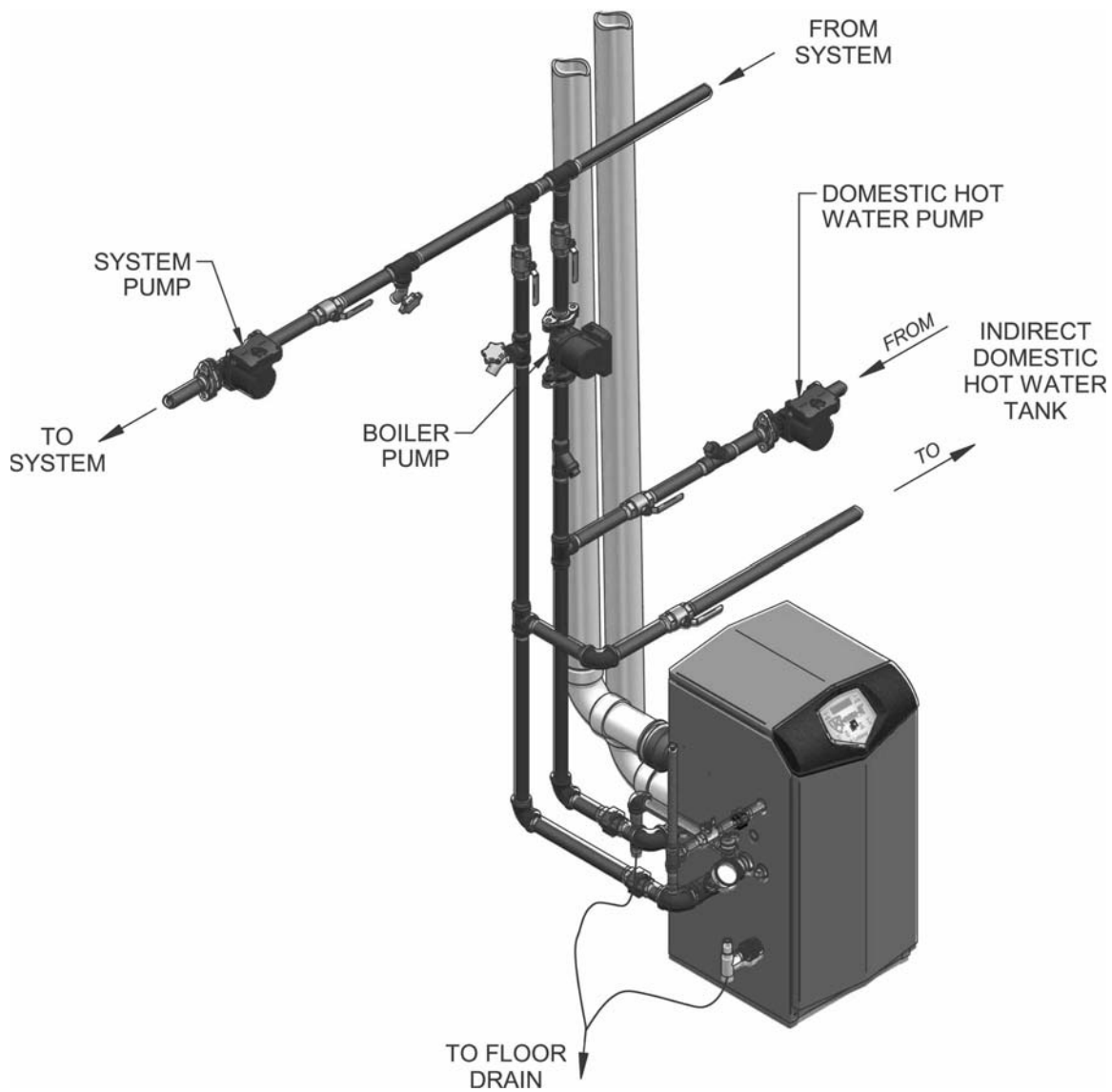

## 6 Hydronic piping

Figure 41 Pressure Drop vs. Flow - Models 80 - 210

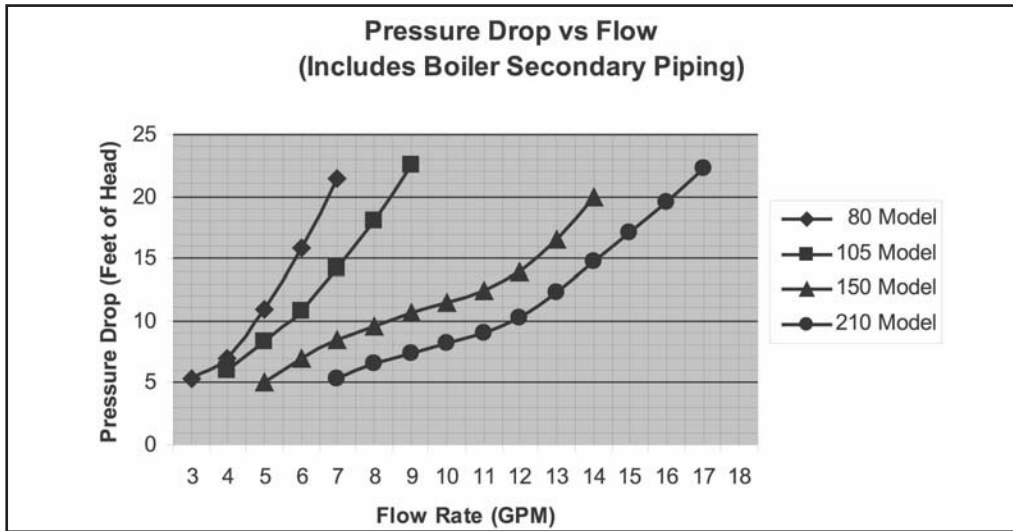

Figure 42 Pressure Drop vs. Flow - Models 285 - 500

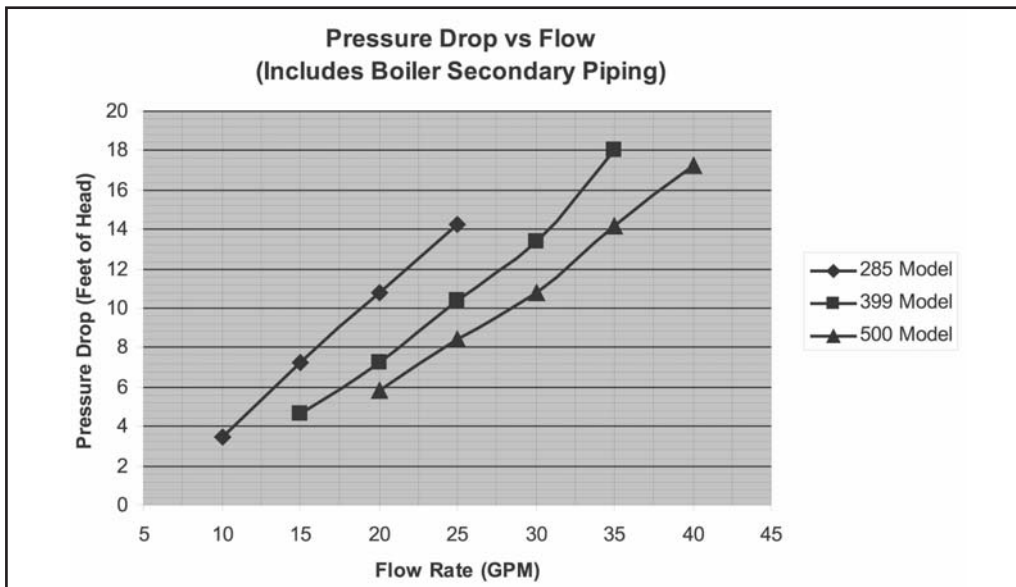

Table 5 System Temperature Rise Chart

SYSTEM TEMPERATURE RISE CHART										
(*Includes Boiler Secondary Piping)										
Model	25°F		30°F		35°F		40°F		45°F	
	GPM	FT/HD	GPM	FT/HD	GPM	FT/HD	GPM	FT/HD	GPM	FT/HD
80	5.9	15.0	4.9	11.5	4.2	7.3	3.7	6.0	3.3	5.7
105	7.7	17.5	6.4	12.1	5.5	9.3	4.8	7.8	4.3	6.0
150	11.0	12.8	9.2	11.0	7.9	9.5	6.9	8.5	6.1	7.1
210	15.5	19.0	12.9	13.0	11.0	9.1	9.7	8.0	8.6	7.1
285	21.0	11.5	17.5	9.1	15.0	7.3	13.1	6.1	11.7	5.0
399	29.4	14.1	24.5	10.3	21.0	7.5	18.4	6.5	16.3	5.5
500	36.8	15.5	30.7	12.5	26.3	9.4	23.0	7.3	20.5	6.3

\*Boiler secondary system piping based on 20 feet of piping, 4 - 90° elbows, and 2 - fully ported ball valves.

## 6 Hydronic piping *(continued)*

Table 6 Pump Recommendations

Boiler Pump and Minimum Pipe Size Chart				
Model	Pipe Size	Taco	Grundfos	Bell & Gossett
80	1"	007	UPS15-58FC (Med)	NRF-22
105	1"	007	UPS15-58FC (Med)	NRF-22
150	1"	0010	UPS15-58FC (High)	NRF-22
210	1"	0010	UPS15-58FC (High)	NRF-22
285	1-1/4"	0010	UP26-64F	NRF-33
399	1-1/2"	0011	UP26-96F	PL-36
500	1-1/2"	0012	UP26-99F	PL-36

**NOTICE**

Pump sizing and flow requirements are based on 20 feet of piping, 4 - 90° elbows, and 2 - fully ported ball valves.

**NOTICE**

It is required that near boiler piping systems utilize *Primary/Secondary* configurations as shown in FIG.'s 43 - 48 only. The use of other near boiler piping configurations could result in improper building and system flow rates leading to inadvertent boiler high limit shutdowns and poor system performance.

### Near boiler piping components

**1. Boiler system piping:**

Boiler system piping MUST be sized per the pipe requirements listed in Table 6. Reducing the pipe size can restrict the flow rate through the boiler, causing inadvertent high limit shutdowns and poor system performance. Flow rates are based on 20 feet of piping, 4 - 90° elbows, and 2 - fully ported ball valves.

**2. Boiler system circulating pump:**

A boiler circulating pump will be provided by the factory (field supplied on Models 399/500) based on 20 feet of piping, 4 - 90° elbows, and 2 - fully ported ball valves.

**3. Domestic hot water circulating pump:**

Field supplied. The pump MUST be sized to meet the specified minimum flow requirements listed in FIG.'s 41 and 42. Consult the indirect water heater operating guide to determine flow characteristics for the selected product used.

**4. Boiler isolation valves:**

Field supplied. Full port ball valves are required. Failure to use full port ball valves could result in a restricted flow rate through the boiler.

**5. Check valves:**

Field supplied. Check valves are recommended for installation as shown in FIG.'s 43 - 48. Failure to install check valves could result in a reverse flow condition during pump(s) off cycle.

**6. Domestic indirect hot water isolation valves:**

Field supplied. Full port ball valves are required. Failure to use full port ball valves could result in a restricted flow rate through the boiler.

**7. Anti-scald mixing valve:**

Field supplied. An anti-scald mixing valve is recommended when storing domestic hot water above 115°F.

**8. Unions:**

Field supplied. Recommended for unit serviceability.

**9. Temperature and pressure gauge:**

Factory supplied. The temperature and pressure gauge is shipped loose. It is the responsibility of the contractor to install the temperature and pressure gauge on the boiler water outlet.

**10. Pressure relief valve:**

Factory supplied. The pressure relief valve is sized to ASME specifications.

**11. Boiler purge valve:**

Field supplied. The boiler purge valve is used to remove entrapped air from the heat exchanger during start-up.

**12. Optional system temperature sensor:**

Lochinvar offers an optional system temperature sensor. The sensor is to be installed in the heating loop downstream from the boiler hot water piping and heating loop junction. Typically the sensor will be located far enough downstream to sense system diluted water temperature.

# 6 Hydronic piping

Figure 43 Single Boiler Zoned with Circulators

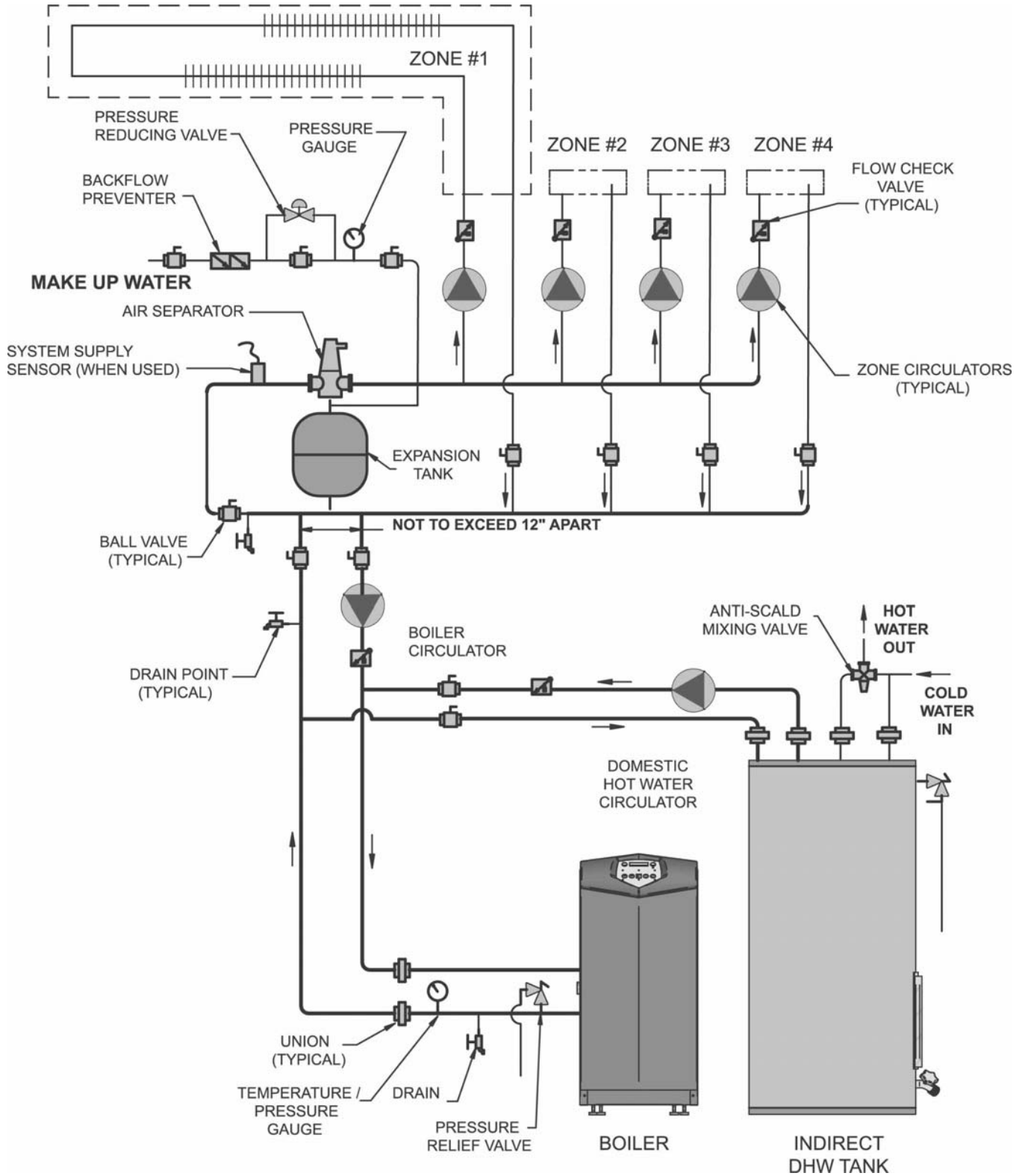



# 6 Hydronic piping (continued)

Figure 44 Multiple Boilers Zoned with Circulators

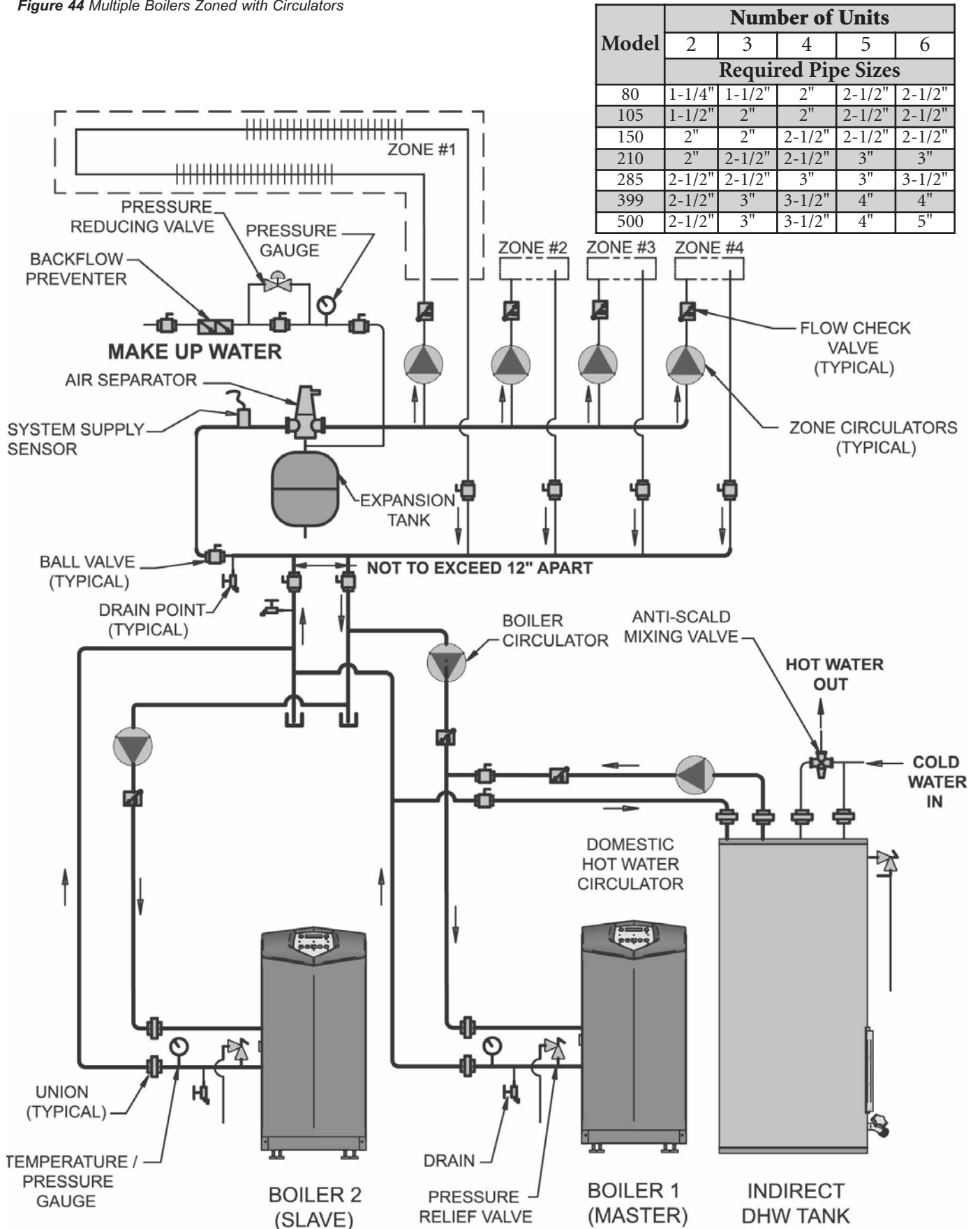

# 6 Hydronic piping

Figure 45 Single Boiler Zoned with Valves

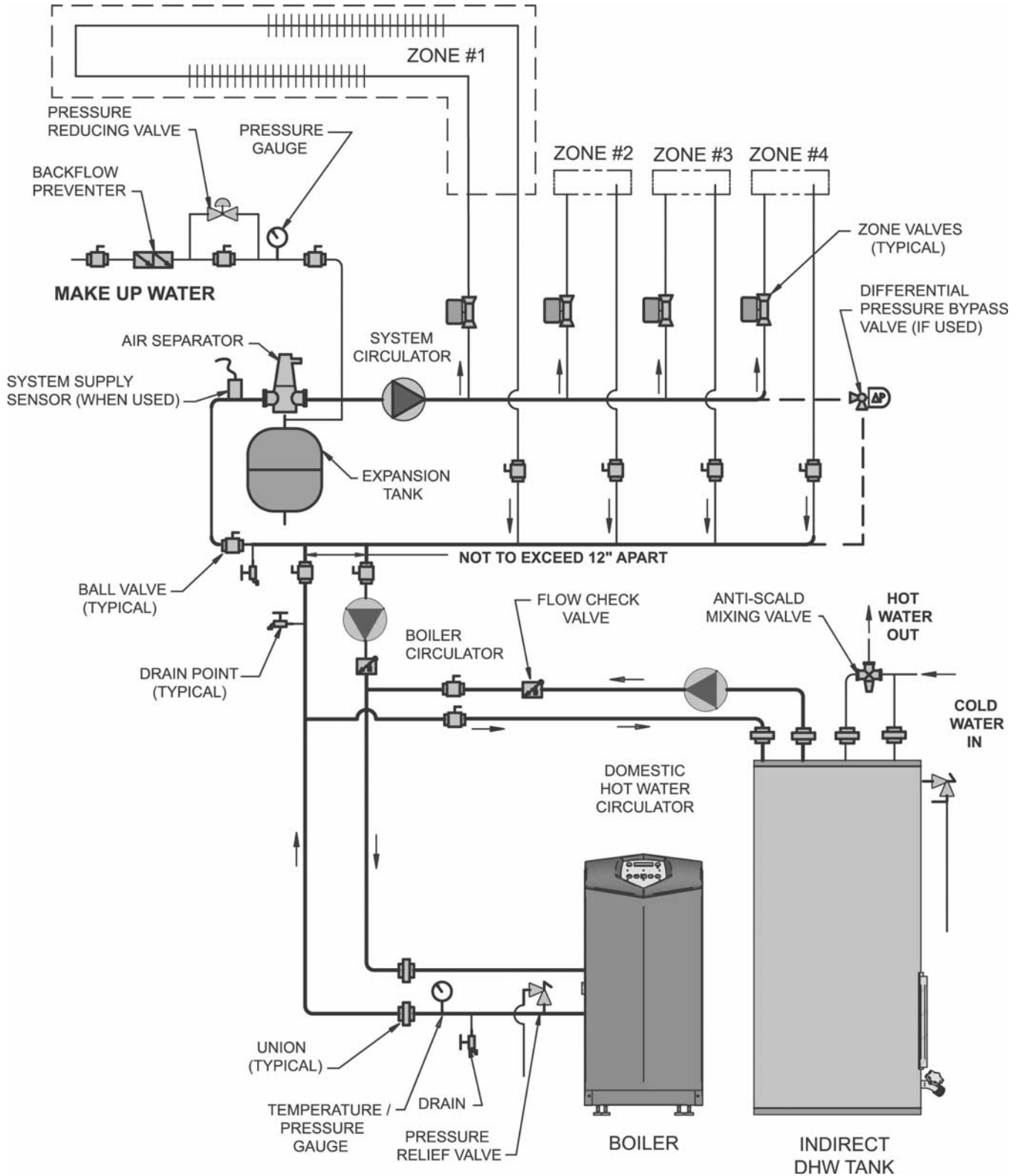

# 6 Hydronic piping (continued)

Figure 46 Multiple Boilers Zoned with Valves

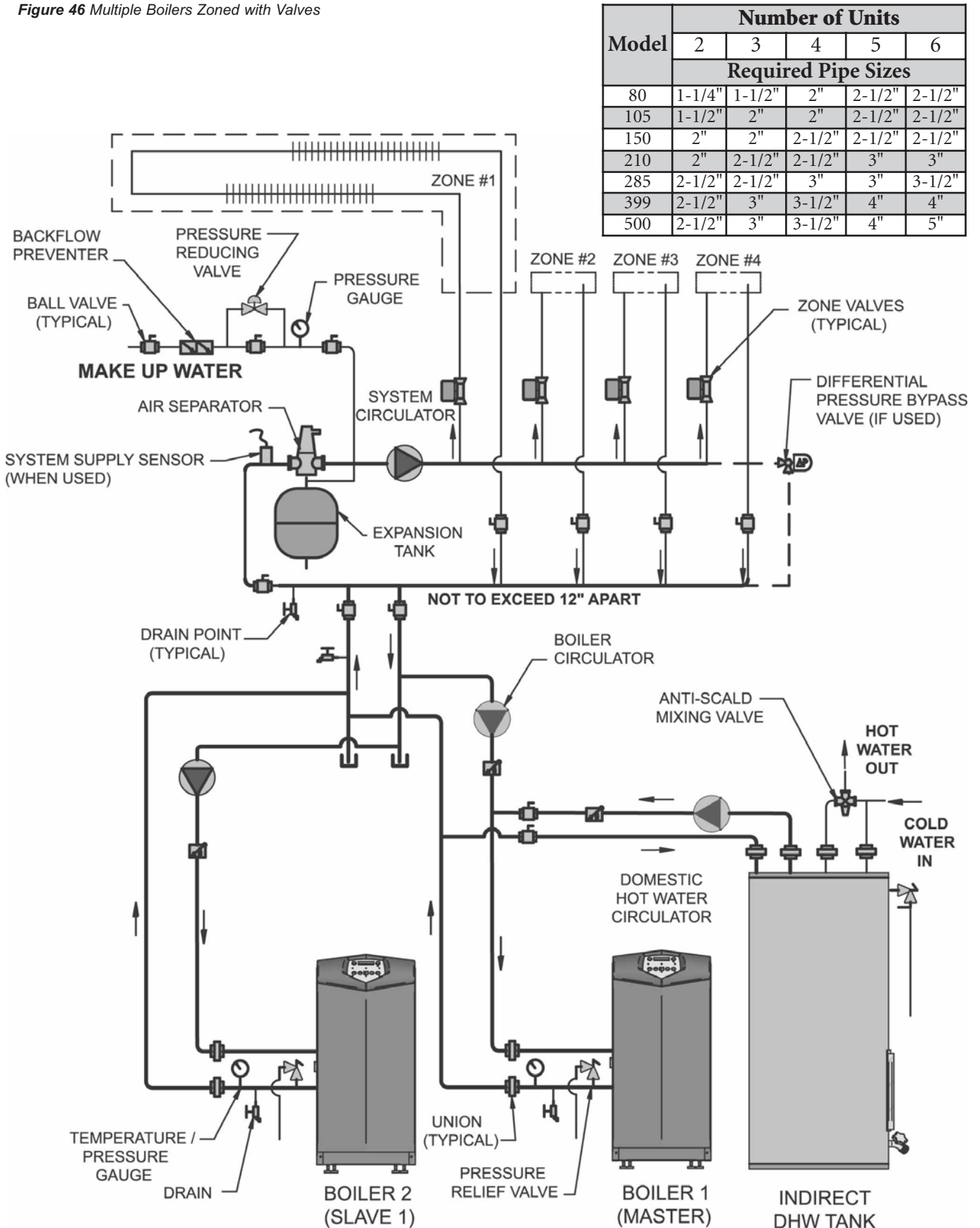

Model	Number of Units				
	2	3	4	5	6
<b>Required Pipe Sizes</b>					
80	1-1/4"	1-1/2"	2"	2-1/2"	2-1/2"
105	1-1/2"	2"	2"	2-1/2"	2-1/2"
150	2"	2"	2-1/2"	2-1/2"	2-1/2"
210	2"	2-1/2"	2-1/2"	3"	3"
285	2-1/2"	2-1/2"	3"	3"	3-1/2"
399	2-1/2"	3"	3-1/2"	4"	4"
500	2-1/2"	3"	3-1/2"	4"	5"

# 6 Hydronic piping

Figure 47 Single Boiler - Non-Zoned Primary/Secondary Piping

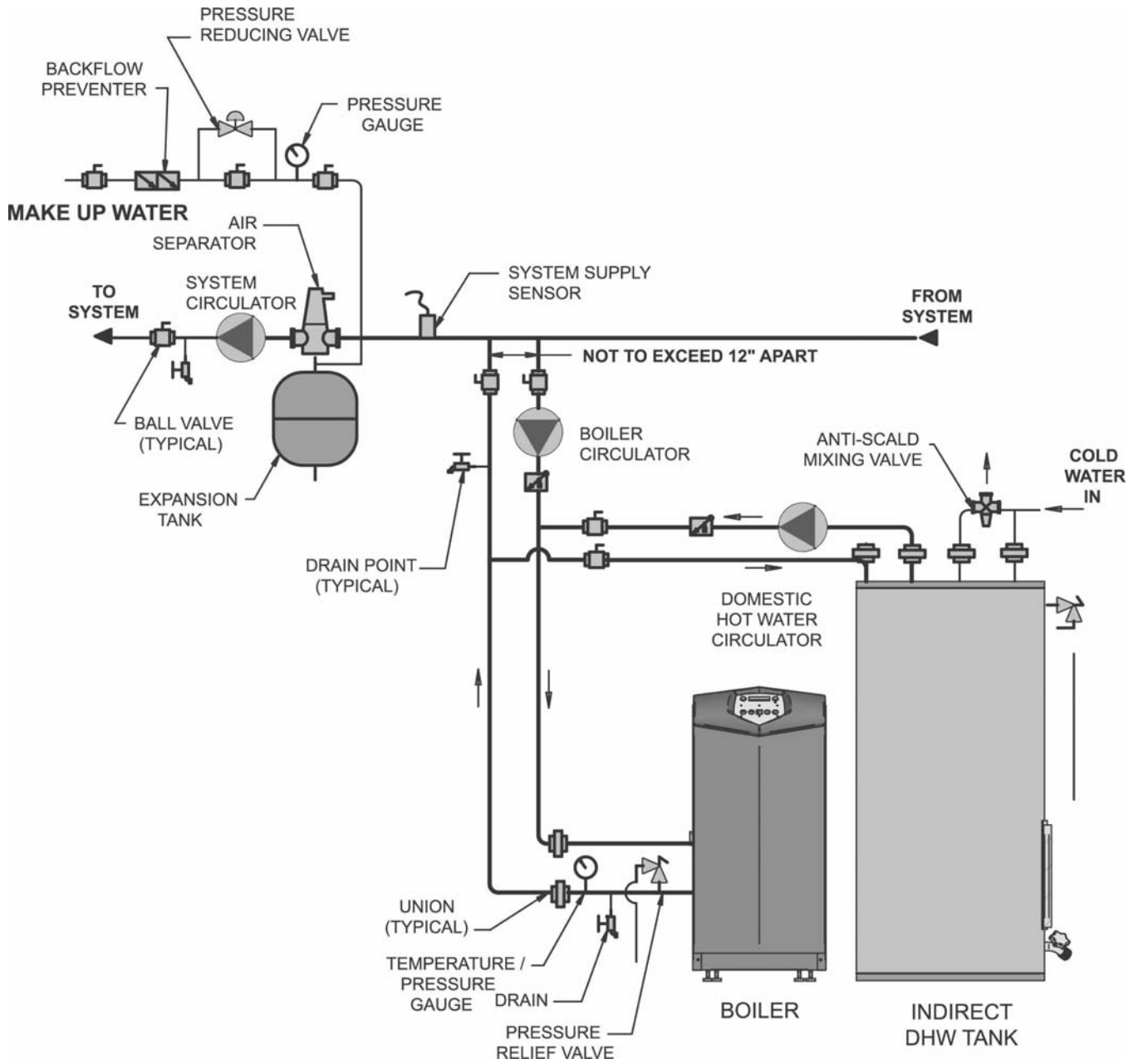

## 6 Hydronic piping *(continued)*

**Figure 48** Multiple Boilers - Non-Zoned Primary/Secondary Piping

Model	Number of Units				
	2	3	4	5	6
	Required Pipe Sizes				
80	1-1/4"	1-1/2"	2"	2-1/2"	2-1/2"
105	1-1/2"	2"	2"	2-1/2"	2-1/2"
150	2"	2"	2-1/2"	2-1/2"	2-1/2"
210	2"	2-1/2"	2-1/2"	3"	3"
285	2-1/2"	2-1/2"	3"	3"	3-1/2"
399	2-1/2"	3"	3-1/2"	4"	4"
500	2-1/2"	3"	3-1/2"	4"	5"

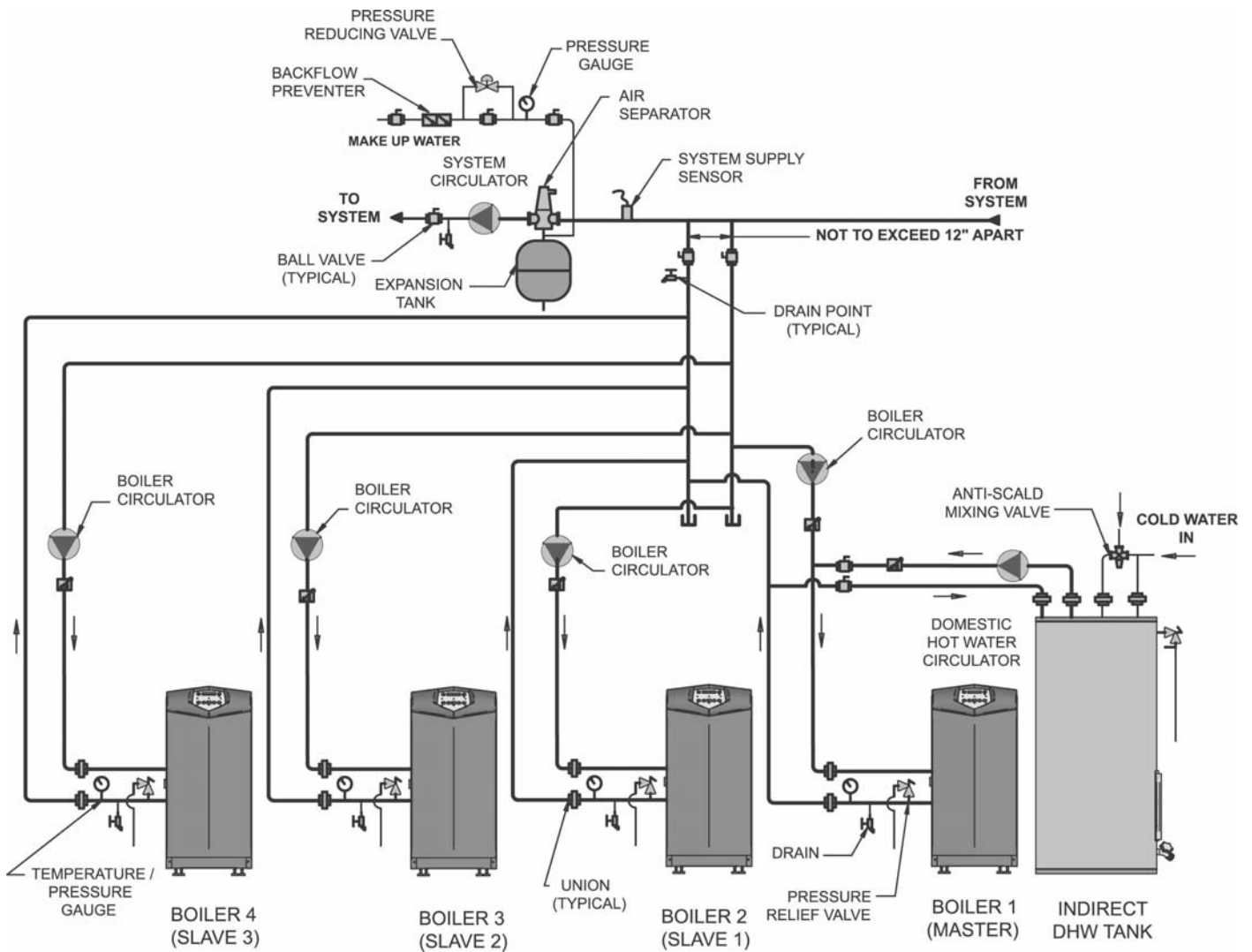

# 7 Gas connections

## Connecting gas supply piping

1. Remove the top access panel and refer to FIG.'s 49 and 50 to pipe gas to the boiler.
  - a. Install ground joint union for servicing, when required.
  - b. Install manual shutoff valve in gas supply piping outside boiler jacket when required by local codes or utility requirements.
  - c. In Canada – When using manual main shutoff valves, it must be identified by the installer.

**Figure 49** Gas Supply Piping - Models 80 - 210

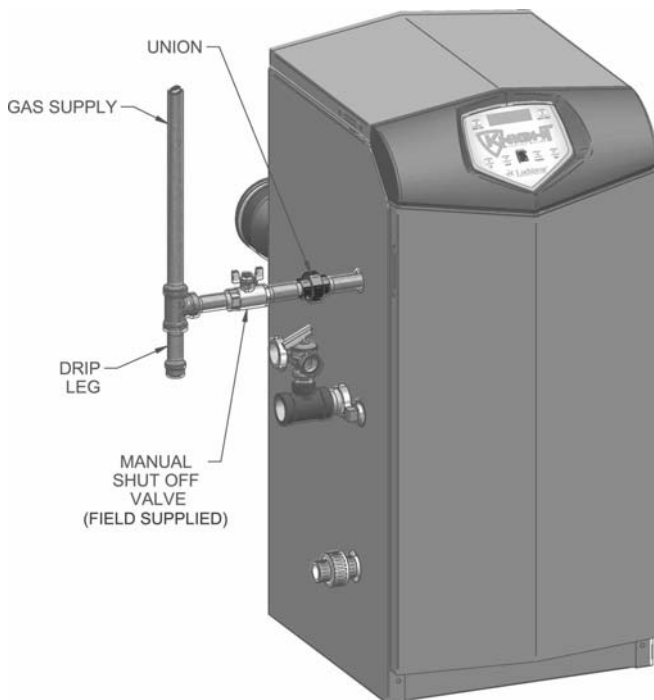

**Figure 50** Gas Supply Piping - Models 285 - 500

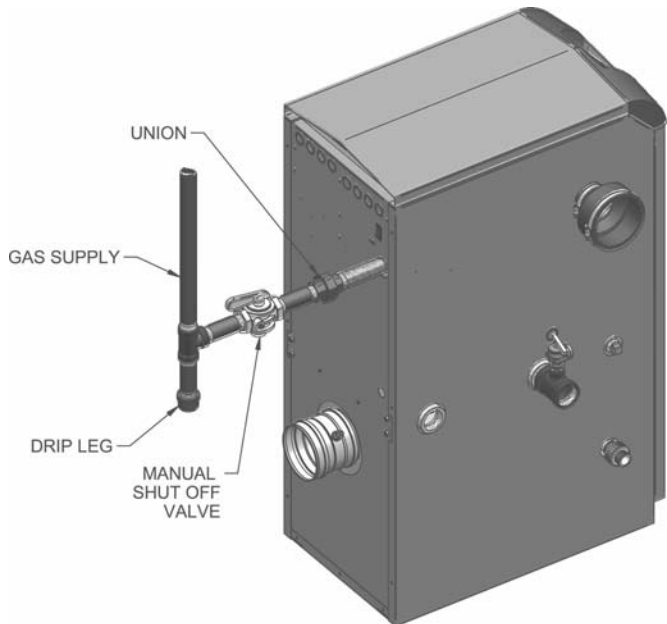

2. Support piping with hangers, not by the boiler or its accessories.

**⚠ WARNING**

The gas valve and blower will not support the weight of the piping. Do not attempt to support the weight of the piping with the boiler or its accessories. Failure to comply could result in severe personal injury, death, or substantial property damage.

3. Purge all air from the gas supply piping.
4. Before placing the boiler in operation, check the boiler and its gas connection for leaks.
  - a. Close manual main shutoff valve during any pressure testing at less than 13 inches w.c.
  - b. Disconnect the boiler and gas valve from the gas supply piping during any pressure testing greater than 13 inches w.c.

**⚠ WARNING**

Do not check for gas leaks with an open flame – use the bubble test. Failure to use the bubble test or check for gas leaks can cause severe personal injury, death, or substantial property damage.

5. Use pipe sealing compound compatible with propane gases. Apply sparingly only to male threads of the pipe joints so that pipe dope does not block gas flow.

## 7 Gas connections *(continued)*

**⚠ WARNING** Failure to apply pipe sealing compound as detailed in this manual can result in severe personal injury, death, or substantial property damage.

**⚠ WARNING** Knight boilers are typically shipped ready to fire on natural gas. Check boiler rating plate to determine which fuel the boiler is set for. If set to natural gas, it may be converted to LP by installing an orifice (see page 12). In order to operate on LP gas, an orifice **MUST BE** installed. Failure to comply could result in severe personal injury, death, or substantial property damage.

**⚠ WARNING** Use two wrenches when tightening gas piping at boiler (FIG. 51), using one wrench to prevent the boiler gas line connection from turning. Failure to support the boiler gas connection pipe to prevent it from turning could damage gas line components.

**Figure 51** Inlet Pipe with Backup Wrench

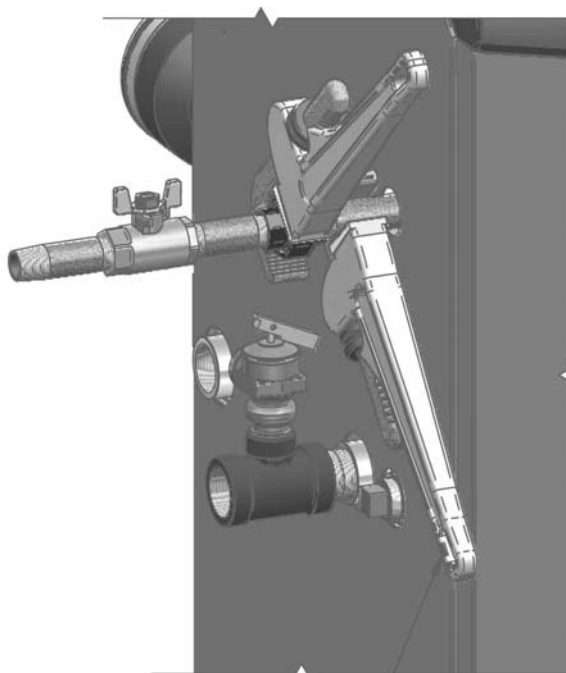

USE BACK UP WRENCH  
TO PREVENT PIPE FROM  
ROTATING

**NOTICE** Maximum inlet gas pressure must not exceed the value specified. Minimum value listed is for the purposes of input adjustment.

### Natural gas:

#### Pipe sizing for natural gas

1. Refer to Table 7 for pipe length and diameter. Based on rated boiler input (divide by 1,000 to obtain cubic feet per hour).
  - a. Table 7 is only for natural gas with specific gravity 0.60 inches, with a pressure drop through the gas piping of 0.5 inches w.c.
  - b. For additional gas pipe sizing information, refer to ANSI Z223.1 (or B149.1 or B149.2 for Canadian installations).

#### Natural gas supply pressure requirements

1. Pressure required at the gas valve inlet pressure port:
  - Maximum 10.5 inches w.c. with no flow (lockup) or with boiler on.
  - Minimum 4 inches w.c. with gas flowing (verify during boiler startup).
2. Install 100% lockup gas pressure regulator in supply line if inlet pressure can exceed 10.5 inches w.c. at any time. Adjust lockup regulator for 10.5 inches w.c. maximum.

### Propane Gas:

**⚠ WARNING** Knight boilers are typically shipped ready to fire on natural gas. Check boiler rating plate to determine which fuel the boiler is set for. If set to natural gas, it may be converted to LP by installing an orifice (see page 12). In order to operate on LP gas, an orifice **MUST BE** installed. Failure to comply could result in severe personal injury, death, or substantial property damage.

#### Pipe sizing for propane gas

1. Contact gas supplier to size pipes, tanks, and 100% lockup gas pressure regulator.

#### Propane Supply Pressure Requirements

1. Adjust propane supply regulator provided by the gas supplier for 13 inches w.c. maximum pressure.
2. Pressure required at gas valve inlet pressure port:
  - Maximum 13 inches w.c. with no flow (lockup) or with boiler on.
  - Minimum 8 inches w.c. with gas flowing (verify during boiler startup).

# 7 Gas connections

**Table 7 Natural Gas Pipe Size Chart**

Nominal Iron Pipe Size (Inches)	Single Unit Natural Gas Pipe Capacity Chart Length of Pipe in Straight Feet													
	10	20	30	40	50	60	70	80	90	100	125	150	175	200
1/2	175	120	97	82	N/A	N/A	N/A	N/A	N/A	N/A	N/A	N/A	N/A	N/A
3/4	369	256	205	174	155	141	128	121	113	106	95	86	79	74
1	697	477	384	328	292	267	246	236	210	200	179	164	149	138
1-1/4	1400	974	789	677	595	543	502	472	441	410	369	333	308	287
1-1/2	2150	1500	1210	1020	923	830	769	707	666	636	564	513	472	441
2	4100	2820	2260	1950	1720	1560	1440	1330	1250	1180	1100	974	871	820
2-1/2	6460	4460	3610	3100	2720	2460	2310	2100	2000	1900	1700	1540	1400	1300
3	11200	7900	6400	5400	4870	4410	4000	3800	3540	3330	3000	2720	2500	2340
4	23500	16100	13100	11100	10000	9000	8300	7690	7380	6870	6150	5640	5130	4720

**⚠ WARNING**

Knights boilers are typically shipped ready to fire on natural gas. Check boiler rating plate to determine which fuel the boiler is set for. If set to natural gas, it may be converted to LP by installing an orifice (see page 12). In order to operate on LP gas, an orifice **MUST BE** installed. Failure to comply could result in severe personal injury, death, or substantial property damage.

## Check inlet gas supply

**NOTICE**

CSA or UL listed flexible gas connections are acceptable, but you must exercise caution to ensure that the line has adequate capacity to allow your boiler to fire at full rate. Consult with local codes for proper installation or service procedures.

**⚠ WARNING**

DO NOT adjust or attempt to measure gas valve outlet pressure. The gas valve is factory-set for the correct outlet pressure. This setting is suitable for natural gas and propane, requiring no field adjustment. Attempting to alter or measure the gas valve outlet pressure could result in damage to the valve, causing potential severe personal injury, death, or substantial property damage.

The gas piping must be sized for the proper flow and length of pipe, to avoid excessive pressure drop. Both the gas meter and the gas regulator must be properly sized for the total gas load.

If you experience a pressure drop greater than 1 inch w.c., the meter, regulator, or gas line is undersized or in need of service. Perform the steps below when checking inlet gas supply:

1. Turn the main power switch to the “OFF” position.
2. Shut off gas supply at the manual gas valve in the gas piping to the appliance.

3. Loosen the set screw one (1) full turn from inside the pressure tap on top of the gas valve. Place the tubing of the manometer over the tap once the set screw is loosened as shown in FIG.s 52 - 54.
4. Slowly turn on the gas supply at the field installed manual gas valve.
5. Turn the power switch to the “ON” position.
6. Adjust the temperature set point on the control panel of the SMART SYSTEM control module to call for heat.
7. Observe the gas supply pressure as the burner fires at 100% of rated input. Percent of burner input will be displayed on the control panel.
8. Ensure inlet pressure is within specified range. Minimum and maximum gas supply pressures are specified in this section of the manual.
9. If gas supply pressure is within normal range and no adjustments are needed, proceed on to Step 11.
10. If the gas pressure is out of range, contact the gas utility, gas supplier, qualified installer or service agency to determine the necessary steps to provide proper gas pressure to the control.
11. Turn the power switch to the “OFF” position.
12. Shut off the gas supply at the manual gas valve in the gas piping to the appliance.
13. Remove the manometer from the pressure tap on top of the gas valve. Re-tighten the set screw inside the pressure tap.



## 7 Gas connections *(continued)*

### **⚠ WARNING**

When re-tightening the set screw, be sure to tighten securely to prevent gas leaks.

Do not check for gas leaks with an open flame -- use the bubble test. Failure to use the bubble test or check for gas leaks can cause severe personal injury, death, or substantial property damage.

14. Turn on the gas supply at the manual gas valve.
15. Turn the power switch to the "ON" position.
16. Adjust the temperature set point on the control panel of the SMART SYSTEM control module to the desired water temperature so the appliance will call for heat.
17. Check burner performance by cycling the system while you observe burner response. The burner should ignite promptly. Flame pattern should be stable. Turn system off and allow burner to cool, then cycle burner again to ensure proper ignition and flame characteristics.

**Figure 52** Inlet Gas Supply Check - Models 80 - 285

LOOSEN THE SET SCREW ONE (1) FULL TURN AND PLACE THE MANOMETER TUBING OVER THE PRESSURE TAP.

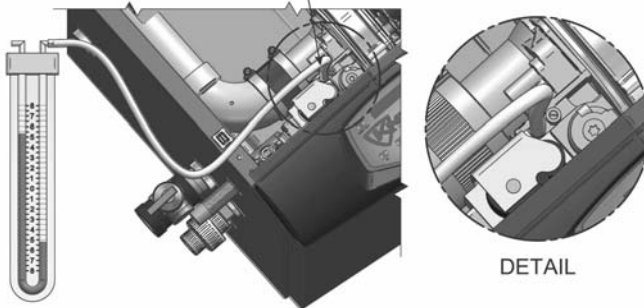

**Figure 53** Inlet Gas Supply Check - Model 399

LOOSEN THE SET SCREW ONE (1) FULL TURN AND PLACE THE MANOMETER TUBING OVER THE PRESSURE TAP.

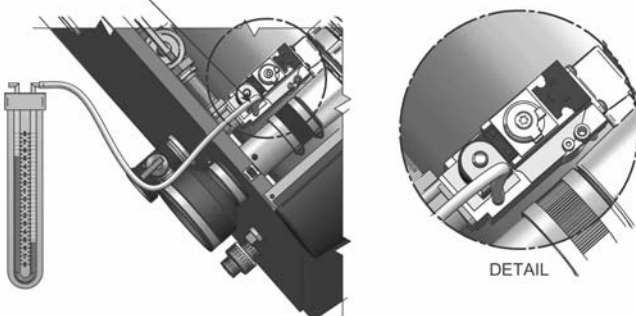

**Figure 54** Inlet Gas Supply Check - Model 500

REMOVE THE 1/8" PIPE PLUG ON THE INLET FLANGE TO THE VALVE AND INSTALL A SUITABLE 1/8" FITTING (FIELD SUPPLIED) FOR THE MANOMETER TUBING.

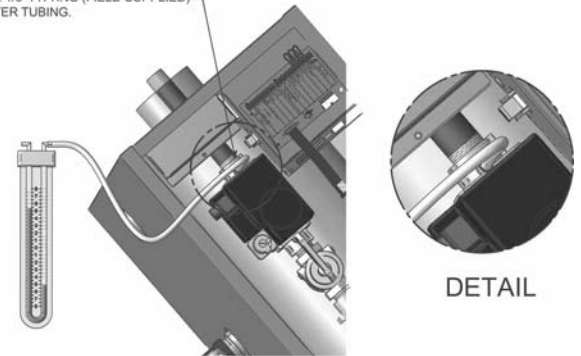

### Gas Pressure

The gas pressure must remain between 4 inches w.c. (natural), 8 inches w.c (LP) minimum and 10.5 inches w.c. (natural), 13 inches w.c. (LP) maximum during stand-by (static) mode and while in operating (dynamic) mode. If an in-line regulator is used, it must be a minimum of 10 feet from the Knight boiler. It is very important that the gas line is properly purged by the gas supplier or utility company. Failure to properly purge the lines or improper line sizing, will result in ignition failure.

The problem is especially noticeable in NEW LP installations and also in empty tank situations. This can also occur when a utility company shuts off service to an area to provide maintenance to their lines.

### Gas valve replacement

The gas valve **MUST NOT** be replaced with a conventional gas valve under any circumstances. As an additional safety feature, this gas valve has a flanged connection to the venturi and blower.

### **⚠ WARNING**

Failure to follow all precautions could result in fire, explosion, or death!

### **⚠ WARNING**

DO NOT adjust or attempt to measure gas valve outlet pressure. The gas valve is factory-set for the correct outlet pressure. This setting is suitable for natural gas and propane, requiring no field adjustment. Attempting to alter or measure the gas valve outlet pressure could result in damage to the valve, causing potential severe personal injury, death, or substantial property damage.

## 8 Field wiring

### ⚠ WARNING

ELECTRICAL SHOCK HAZARD – For your safety, turn off electrical power supply before making any electrical connections to avoid possible electric shock hazard. Failure to do so can cause severe personal injury or death.

### NOTICE

Wiring must be N.E.C. Class 1.

If original wiring as supplied with boiler must be replaced, use only type 105°C wire or equivalent.

Boiler must be electrically grounded as required by National Electrical Code ANSI/NFPA 70 – latest edition.

### ⚠ CAUTION

Label all wires prior to disconnection when servicing controls. Wiring errors can cause improper and dangerous operation.

### Installation must comply with:

1. National Electrical Code and any other national, state, provincial, or local codes, or regulations.
2. In Canada, CSA C22.1 Canadian Electrical Code Part 1, and any local codes.

### Line voltage connections

1. Connect 120 vac power wiring to the line voltage terminal strip in the junction box, as shown in FIG. 55.
2. Provide and install a fused disconnect or service switch (15 amp recommended) as required by the code (see FIG. 55).
3. On Models 80 - 285 the boiler pump is shipped loose. Wire the boiler pump as shown in FIG. 55.
4. When connecting a domestic hot water (DHW) pump, connect the wiring to the line voltage terminal strip as shown in FIG. 55.
5. To activate a system pump, wire as shown in FIG. 55. If the motor is larger than 1/3 HP, you must install a relay.

Figure 55 Line Voltage Field Wiring Connections

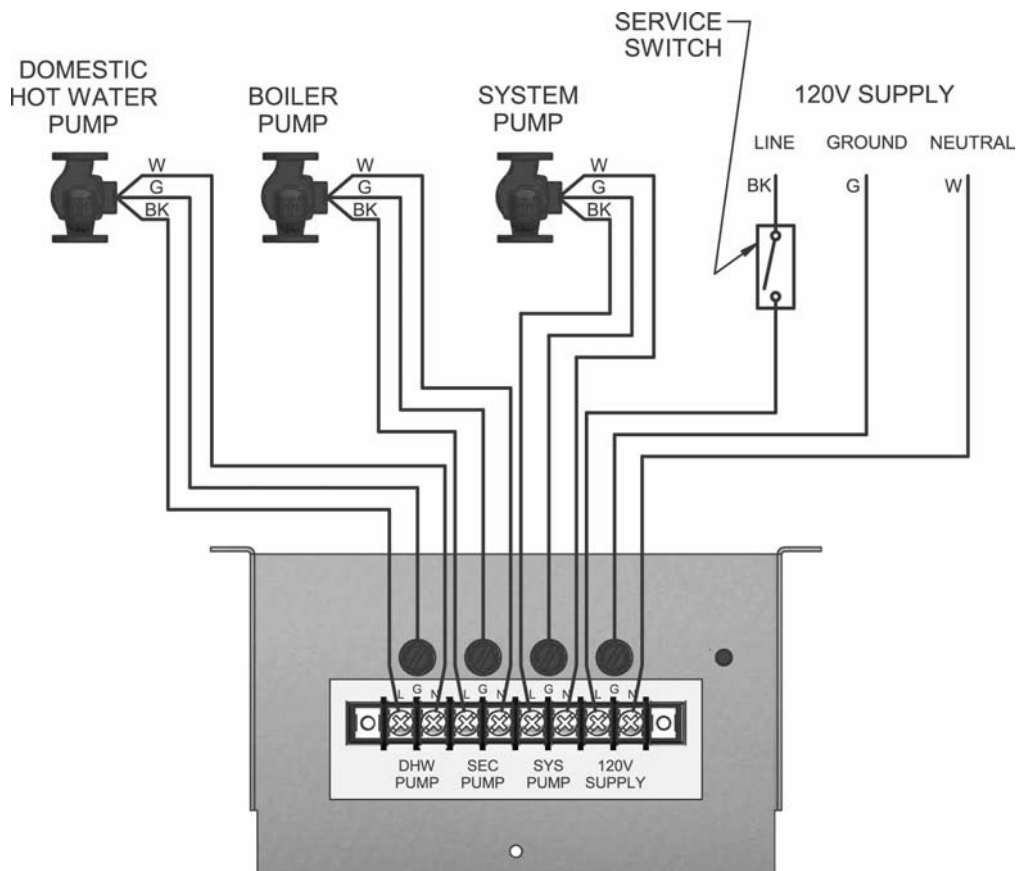

## 8 Field wiring *(continued)*

### Low voltage connections

1. Route all low voltage wires through the knockouts in the rear of the boiler, as shown in FIG. 56.
2. Connect low voltage wiring to low voltage connection board as shown in FIG. 57 on page 45 of this manual and the boiler wiring diagram.

**Figure 56** Routing Field Wiring

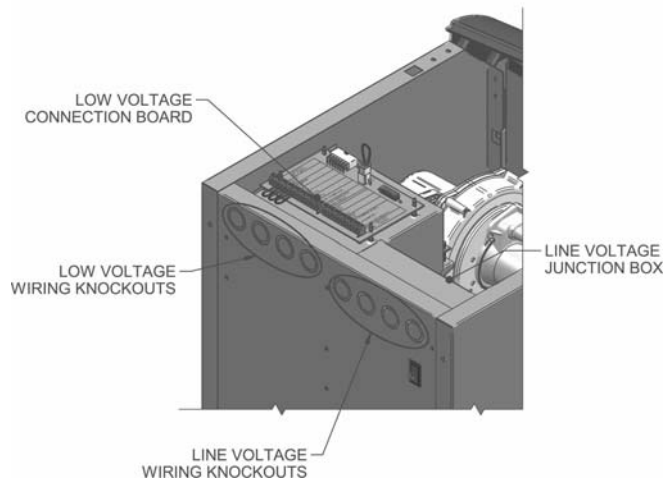

### Thermostat

1. Connect the room thermostat or end switch (isolated contact only) to terminals R and W, as shown in FIG. 57.
2. Install the thermostat on the inside wall away from influences of drafts, hot or cold water pipes, lighting fixtures, television, sunlight, or fireplaces.
3. Thermostat anticipator (if applicable):
  - a. If connected directly to boiler, set for 0.1 amps.
  - b. If connected to relays or other devices, set to match total electrical power requirements of connected devices. See device manufacturers' specifications and thermostat instructions for details.

### Outdoor temperature sensor

1. Connect outdoor temperature sensor (FIG. 57) to the outdoor sensor terminals on the connection board to enable outdoor reset operation of the Knight boiler. If fixed temperature operation is required, do not install outdoor sensor.
2. Mount the sensor on an exterior wall, shielded from direct sunlight or flow of heat or cooling from other sources.
3. Route sensor wires through a knockout at the rear of the boiler (see FIG. 56).

### DHW thermostat

1. Connect storage indirect water heater (DHW) thermostat (FIG. 57) to the DHW thermostat terminals on the connection board.

### Auxiliary device relay

1. If an auxiliary device (e.g., louvers) needs to operate when the boiler fires, it can be controlled by this output. Connect these terminals to a 24 vac relay coil, which is wired to operate the auxiliary device (FIG. 57).

### Auxiliary device proving switch

1. When the operation of an auxiliary device needs to be verified before the boiler fires, remove the jumper wire from these terminals and connect them to the normally open contacts on its proving switch (FIG. 57).

### High gas pressure switch

1. If a switch is provided to detect excessive gas pressure, remove the jumper wire from the terminals on the connection board, and then connect them to its normally closed contacts (FIG. 57).

### Low gas pressure switch

1. If a switch is provided to detect low gas pressure, remove the jumper wire from the terminals on the connection board and connect them to its normally open contacts (FIG. 57).
2. If both a high and low gas pressure switch are used, connect their respective contacts in series, and connect them to the terminals on the connection board (FIG. 57).

### Flow switch

1. A flow switch is used to guarantee flow through the boiler before allowing it to fire. The flow switch must be installed in line with the boiler
2. Connect these terminals to the normally open contacts on the flow switch (FIG. 57).

## 8 Field wiring *(continued)*

### System supply sensor

1. By installing an optional system supply sensor into the supply of the primary loop, the temperature of the primary supply can be controlled. The SMART SYSTEM control automatically detects the presence of this sensor, and controls the boiler firing rate to maintain the system supply temperature to the set point (if the outlet sensor control is currently selected).
2. Connect these terminals to the system supply sensor (FIG. 57).

### Boiler management system

1. An external control may be connected to control either the firing rate or the set point of the boiler. Connect the Room Thermostat / Zone Control terminals to the enable output of the external control and connect the 0 - 10 vdc terminals to the 0 - 10 vdc output of the external control.
2. Make sure the ground terminal is connected to the ground output terminal of the external control, and the 0 - 10 vdc terminal is connected to the 0 - 10 vdc terminal of the external control.

### Runtime contacts

The SMART SYSTEM control closes a set of dry contacts whenever the burner is running. This is typically used by Building Management Systems to verify that the boiler is responding to a call for heat.

### Alarm contacts

The SMART SYSTEM control closes another set of contacts whenever the boiler is locked out or the power is turned off. This can be used to turn on an alarm, or signal a Building Management System that the boiler is down.

# 8 Field wiring *(continued)*

Figure 57 Low Voltage Field Wiring Connections

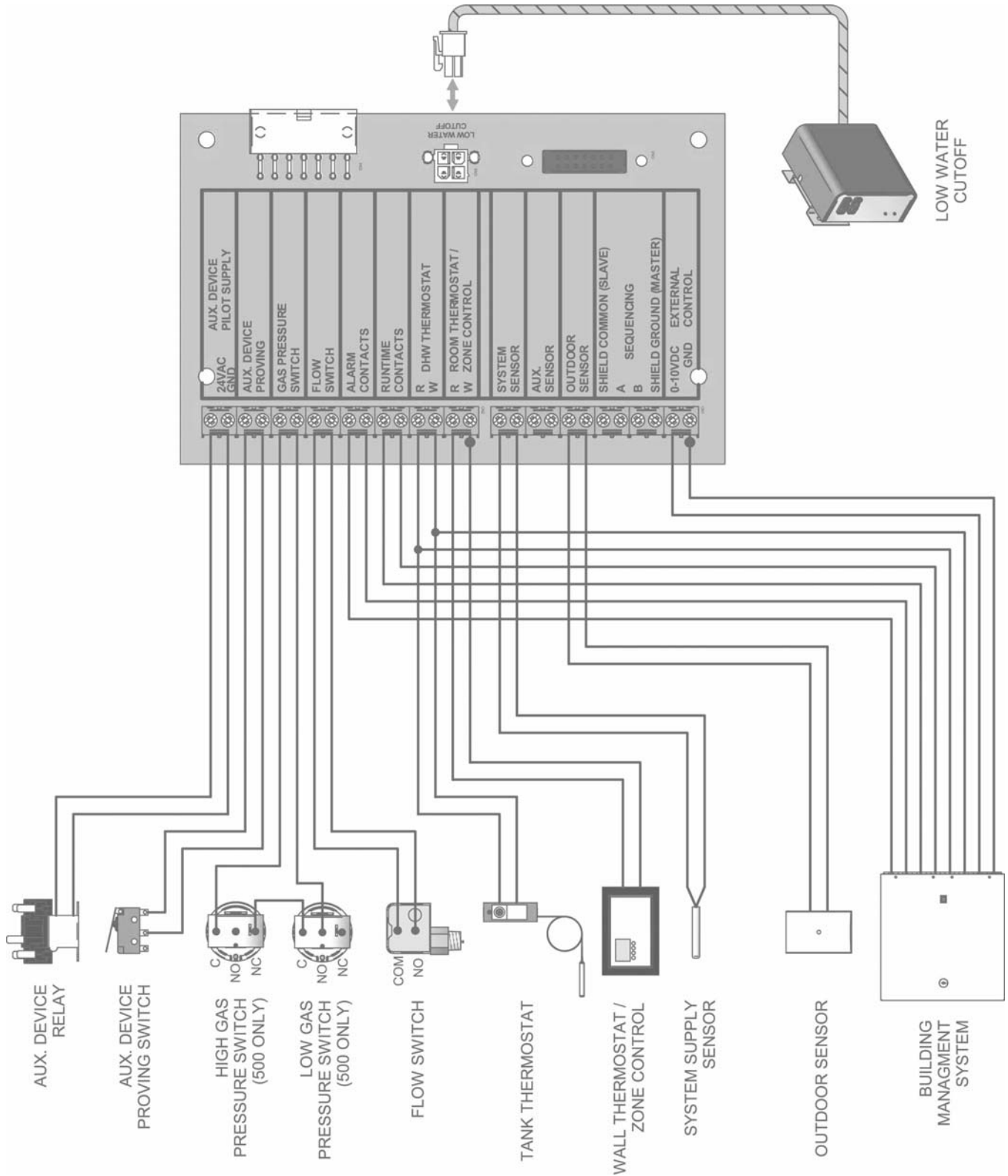

## 9 Condensate disposal

### Condensate drain

1. This boiler is a high efficiency appliance that produces condensate.
2. The side of the boiler has a 1/2 inch PVC union for connection of a 1/2 inch PVC pipe (FIG. 58).
3. Slope condensate tubing down and away from the boiler into a drain or condensate neutralizing filter. Condensate from the Knight boiler will be slightly acidic (typically with a pH from 3 to 5). Install a neutralizing filter if required by local codes.

A Neutralizer Kit is available from the factory (Kit 4004).

4. Install the 1/2 inch PVC tee assembly (shipped with the unit) as shown in FIG. 58.
5. Leave the top of the 1/2 inch tee OPEN. This is needed as a vacuum break.
6. Do not expose condensate line to freezing temperatures.
7. Use only plastic tubing or piping as a condensate drain line (FIG. 58).

#### NOTICE

Use materials approved by the authority having jurisdiction. In the absence of other authority, PVC and CPVC pipe must comply with ASTM D1785 or D2845. Cement and primer must comply with ASME D2564 or F493. For Canada use CSA or ULC certified PVC or CPVC pipe, fittings, and cement.

#### NOTICE

To allow for proper drainage on large horizontal runs, a second line vent may be required and tubing size may need to increase to 1 inch.

The condensate line must remain unobstructed, allowing free flow of condensate. If condensate is allowed to freeze in the line or if the line is obstructed in any other manner, condensate can exit from the boiler tee, resulting in potential water damage to property.

8. A condensate removal pump is required if boiler is below drain. When installing a condensate pump, select one approved for use with condensing boilers and furnaces. The pump should have an overflow switch to prevent property damage from condensate spillage. The switch should be wired to the auxiliary device proving switch terminals on the low voltage connection board.

Figure 58 Condensate Disposal

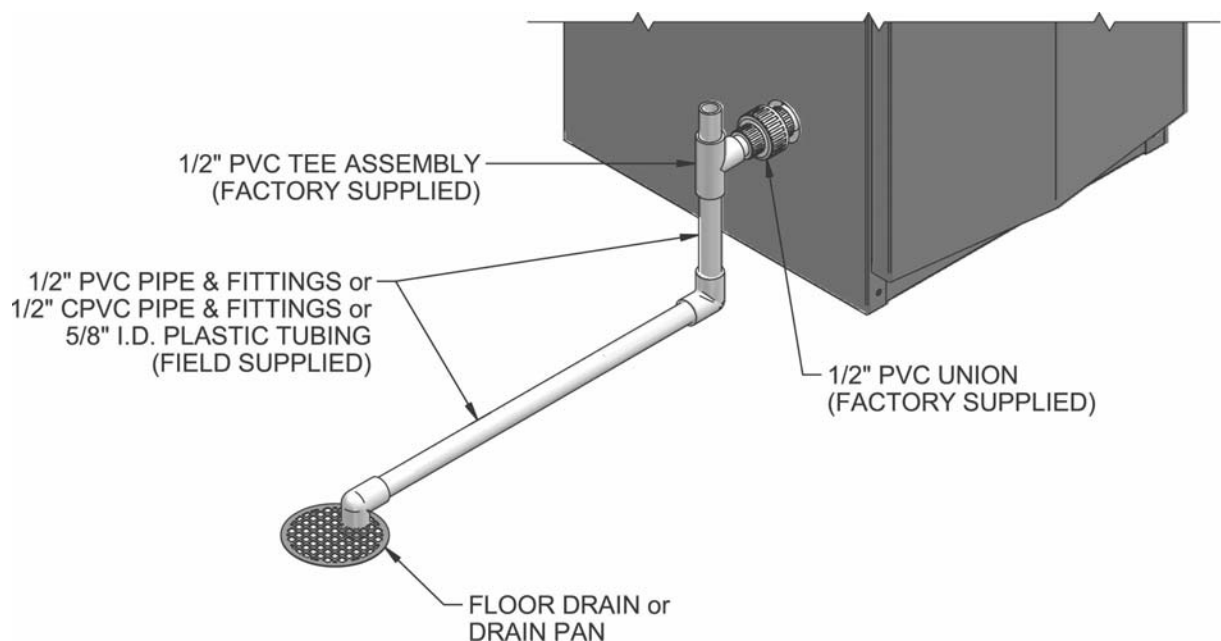

# 10 Start-up

## Check/control water chemistry

**CAUTION** Do not use petroleum-based cleaning or sealing compounds in the boiler system. Damage to elastomer seals and gaskets in the system could occur, resulting in substantial property damage.

### Hardness less than 7 grains

1. Consult local water treatment companies for hard water areas (above 7 grains hardness).

### Chlorine concentration less than 200 ppm

1. Do not fill boiler or operate with water containing chlorine in excess of 200 ppm.
2. Filling with chlorinated fresh water should be acceptable since drinking water chlorine levels are much lower.
3. Do not use the boiler to directly heat swimming pool or spa water.

### Test/replace freeze protection fluid

1. For systems using freeze protection fluids, follow fluid manufacturer's instructions.
2. Freeze protection fluid must be replaced periodically due to degradation of inhibitors over time. Follow all fluid manufacturer's instructions.

### Freeze protection (when used)

1. Determine freeze protection fluid quantity using system water content, following fluid manufacturer's instructions. Boiler water content is listed on page 7. Remember to include expansion tank water content.
2. Local codes may require a backflow preventer or actual disconnect from city water supply.
3. When using freeze protection fluid with automatic fill, install a water meter to monitor water makeup. Freeze protection fluid may leak before the water begins to leak, causing concentration to drop, reducing the freeze protection level.

### Fill and test water system

1. Fill system only after ensuring the water meets the requirements of this manual.
2. Close manual and automatic air vents and boiler drain valve.
3. Fill to correct system pressure. Correct pressure will vary with each application.
  - a. The minimum cold water fill pressure for a residential system is 12 psi.
  - b. Pressure will rise when boiler is turned on and system water temperature increases.

4. At initial fill and during boiler startup and testing, check system thoroughly for any leaks. Repair all leaks before proceeding further.

**WARNING** Eliminate all system leaks. Continual fresh makeup water will reduce boiler life. Minerals can build up in the heat exchanger, reducing heat transfer, overheating the heat exchanger, and causing heat exchanger failure.

### Purge air from water system

1. Purge air from system:
  - a. Connect a hose to the purge valve (see purge/drain valves, in piping diagrams on pages 32 through 37). Route the hose to an area where water can drain and be seen.
  - b. Close the boiler or system isolation valve between the purge valve and fill connection to the system.
  - c. Close zone isolation valves.
  - d. Open quick-fill valve on cold water makeup line.
  - e. Open purge valve.
  - f. One zone at a time, open the isolation valves. Allow water to run through the zone, pushing out the air. Run until no noticeable air flow is present. Close the zone isolation valves and proceed with the next zone. Follow this procedure until all zones are purged.
  - g. Close the quick-fill water valve and purge valve and remove the hose. Open all isolation valves. Watch that system pressure rises to correct cold-fill pressure.
  - h. After the system has operated for a while, eliminate any residual air by using the manual air vents located throughout the system.
  - i. If purge valves are not installed in the system, open the manual air vents in the system one at a time, beginning with the lowest floor. Close the vent when water squirts out. Repeat with remaining vents.
2. Open automatic air vent (diaphragm-type or bladder-type expansion tank systems only) one turn.
3. Open other vents:
  - a. Starting on the lowest floor, open air vents one at a time until water squirts out.
  - b. Repeat with remaining vents.
4. Refill to correct pressure.

# 10 Start-up *(continued)*

## Check for gas leaks

### ⚠ WARNING

Before starting the boiler, and during initial operation, smell near the floor and around the boiler for gas odorant or any unusual odor. Remove the top access panel and smell the interior of the boiler enclosure. Do not proceed with startup if there is any indication of a gas leak. Use an approved leak detection solution. Repair any leaks at once.

### ⚠ WARNING

DO NOT adjust or attempt to measure gas valve outlet pressure. The gas valve is factory set for the correct outlet pressure. This setting is suitable for natural gas and propane, requiring no field adjustment. Attempting to alter or measure the gas valve outlet pressure could result in damage to the valve, causing potential severe personal injury, death, or substantial property damage.

### ⚠ WARNING

Propane boilers only – Your propane supplier mixes an odorant with the propane to make its presence detectable. In some instances, the odorant can fade, and the gas may no longer have an odor. Before startup (and periodically thereafter), have the propane supplier verify the correct odorant level in the gas.

## Check thermostat circuit(s)

1. Disconnect the two external wires connected to the room thermostat terminals on the connection board.
2. Connect a voltmeter across these two incoming wires. Close each thermostat, zone valve, and relay in the external circuit one at a time and check the voltmeter reading across the incoming wires.
3. There should NEVER be a voltage reading.
4. If a voltage does occur under any condition, check and correct the external wiring. (This is a common problem when using 3-wire zone valves.)
5. Once the external thermostat circuit wiring is checked and corrected if necessary, reconnect the external thermostat circuit wires to the connection board. Allow the boiler to cycle.

Figure 59 Condensate Trap

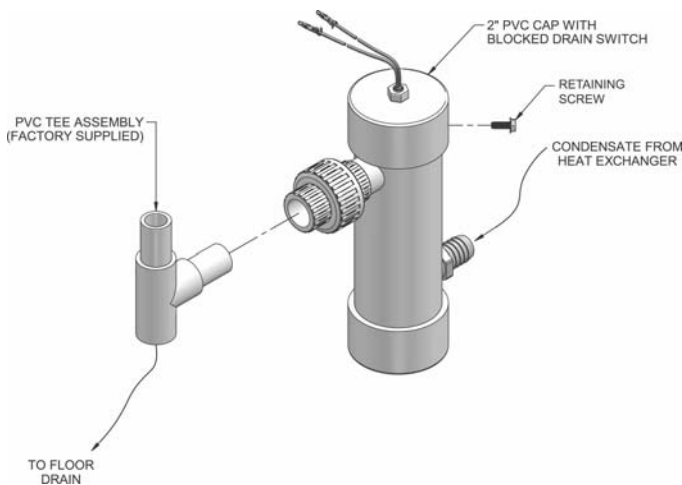

## Inspect/fill condensate system

### Inspect/check condensate lines and fittings

1. Inspect the condensate drain line, condensate PVC fittings and condensate trap.

### Fill condensate trap with water

1. Remove the PVC cap retaining screw from the PVC cap (FIG. 59).
2. Remove the 2 inch PVC cap with the switch located at the top of the trap (FIG. 59).
3. Fill with fresh water until the water begins to pour out of the drain.
4. Replace the cap. Press the cap onto the trap until the cap makes contact with the drain.
5. Replace the retaining screw.

### ⚠ WARNING

The condensate trap (FIG. 59) must be filled with water during all times of boiler operation to avoid flue gas emission from the condensate drain line. Failure to fill the trap could result in severe personal injury or death.



# 10 Start-up *(continued)*

## Final checks before starting the boiler

- ❑ Read the Knight Boiler Service Manual to familiarize yourself with SMART SYSTEM control module operation. Read this manual, pages 50 and 51 for proper steps to start boiler.
- ❑ Verify the boiler and system are full of water and all system components are correctly set for operation.
- ❑ Verify the preparation procedures of Section 10, pages 47 and 48 have been completed.
- ❑ Fill the vent condensate trap with water (removing the retaining screw in order to remove the 2 inch PVC cap with the switch located at the top of the trap). Replace the cap. Press the cap onto the trap until the cap makes contact with the drain. Replace the retaining screw.
- ❑ Verify electrical connections are correct and securely attached.
- ❑ Inspect vent piping and air piping for signs of deterioration from corrosion, physical damage or sagging. Verify air piping and vent piping are intact and correctly installed per this manual.

## Start the boiler

1. Read and follow the Operating instructions in FIG.'s 60 and 61, pages 50 and 51.

## If boiler does not start correctly

1. Check for loose connections, blown fuse or service switch off?
2. Is external limit control (if used) open? Is boiler water temperature above 200°F?
3. Is thermostat set below room temperature?
4. Is gas turned on at meter or boiler?
5. Is incoming gas pressure less than 4 inches w.c.?

If none of the above corrects the problem, refer to the Troubleshooting Section of the Knight Boiler Service Manual.

## Check system and boiler

### ❑ Check water piping

1. Check system piping for leaks. If found, shut down the boiler and repair immediately. (See WARNINGS on pages 47 and 48 (startup) regarding failure to repair leaks.)
2. Vent any remaining air from the system using manual vents. Air in the system will interfere with circulation and cause heat distribution problems and noise.

### ❑ Check vent piping and air piping

1. Check for gastight seal at every connection, seam of air piping, and vent piping.

#### ⚠ WARNING

Venting system must be sealed gastight to prevent flue gas spillage and carbon monoxide emissions, which will result in severe personal injury or death.

### ❑ Check gas piping

1. Check around the boiler for gas odor following the procedure on page 38 of this manual (connecting gas supply piping).

#### ⚠ WARNING

If you discover evidence of any gas leak, shut down the boiler at once. Find the leak source with a bubble test and repair immediately. Do not start the boiler again until corrected. Failure to comply could result in severe personal injury, death, or substantial property damage.

### ❑ Propane boilers – verify conversion

1. Verify propane conversion has been completed per the Propane Conversion instructions.

#### ⚠ WARNING

DO NOT adjust or attempt to measure gas valve outlet pressure. The gas valve is factory-set for the correct outlet pressure. This setting is suitable for natural gas and propane, requiring no field adjustment. Attempting to alter or measure the gas valve outlet pressure could result in damage to the valve, causing potential severe personal injury, death, or substantial property damage.

#### ⚠ WARNING

Knight boilers are typically shipped ready to fire on natural gas. Check boiler rating plate to determine which fuel the boiler is set for. If set to natural gas, it may be converted to LP by installing an orifice (see page 12). In order to operate on LP gas, an orifice MUST BE installed. Failure to comply could result in severe personal injury, death, or substantial property damage.

## Check flame and combustion

1. Turn the main power off to the boiler by placing the “On/Off” switch in the OFF position.
2. Remove the flue temperature sensor from the flue pipe connection. **Note:** Combustion measurements will be made at this point.
3. Turn the main power on to the boiler by placing the “On/Off” switch in the ON position.

# 10 Start-up

Figure 60 Operating Instructions - Models 80 - 285

## FOR YOUR SAFETY READ BEFORE OPERATING

**WARNING:** If you do not follow these instructions exactly, a fire or explosion may result causing property damage, personal injury, or loss of life.

- A. This appliance does not have a pilot. It is equipped with an ignition device which automatically lights the burner. Do not try to light the burner by hand.
  - B. BEFORE OPERATING smell all around the appliance area for gas. Be sure to smell next to the floor because some gas is heavier than air and will settle on the floor.
- WHAT TO DO IF YOU SMELL GAS**
- Do not try to light any appliance.
  - Do not touch any electric switch; do not use any phone in your building.
  - Immediately call your gas supplier from a neighbor's phone. Follow the gas supplier's instructions.
  - If you cannot reach your gas supplier, call the fire department.
- C. Use only your hand to turn the gas control knob. Never use tools. If the handle will not turn by hand, don't try to repair it, call a qualified service technician. Force or attempted repair may result in a fire or explosion.
  - D. Do not use this appliance if any part has been under water. Immediately call a qualified service technician to inspect the appliance and to replace any part of the control system and any gas control which has been under water.

## OPERATING INSTRUCTIONS

1. **STOP!** Read the safety information above on this label.
2. Set the thermostat to lowest setting.
3. Turn off all electric power to the appliance.
4. This appliance is equipped with an ignition device which automatically lights the burner. Do not try to light the burner by hand.
5. Remove top cover.
6. Turn gas shutoff valve clockwise to close valve. Handle will be perpendicular to pipe. Do not force.
7. Wait five (5) minutes to clear out any gas. If you then smell gas, **STOP!** Follow "B" in the safety information above this label. If you don't smell gas, go to next step.
8. Turn gas shutoff valve counterclockwise to open valve. Handle will be parallel to pipe.
9. Install top cover.
10. Turn on all electric power to appliance.
11. Set thermostat to desired setting.
12. If the appliance will not operate, follow the instructions "To Turn Off Gas To Appliance" and call your service technician or gas supplier.

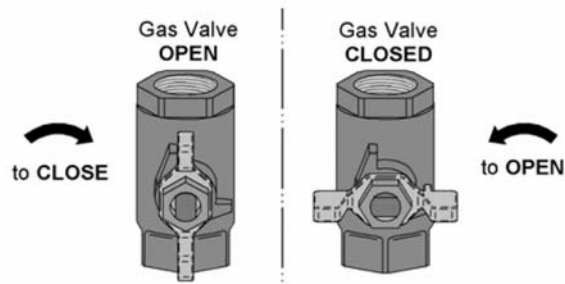

## TO TURN OFF GAS TO APPLIANCE

1. Set the thermostat to lowest setting.
2. Turn off all electric power to the appliance if service is to be performed.
3. Remove top cover.
4. Turn gas shut off valve clockwise to close valve. Handle will be perpendicular to pipe. Do not force
5. Install top cover.

LBL2274 REV B

# 10 Start-up *(continued)*

Figure 61 Operating Instructions - Models 399 - 500

## FOR YOUR SAFETY READ BEFORE OPERATING

**WARNING:** If you do not follow these instructions exactly, a fire or explosion may result causing property damage, personal injury, or loss of life.

- A. This appliance does not have a pilot. It is equipped with an ignition device which automatically lights the burner. Do not try to light the burner by hand.
  - B. BEFORE OPERATING smell all around the appliance area for gas. Be sure to smell next to the floor because some gas is heavier than air and will settle on the floor.
- WHAT TO DO IF YOU SMELL GAS**
- Do not try to light any appliance.
  - Do not touch any electric switch; do not use any phone in your building.
  - Immediately call your gas supplier from a neighbor's phone. Follow the gas supplier's instructions.
  - If you cannot reach your gas supplier, call the fire department.
- C. Use only your hand to turn the gas control knob. Never use tools. If the handle will not turn by hand, don't try to repair it, call a qualified service technician. Force or attempted repair may result in a fire or explosion.
  - D. Do not use this appliance if any part has been under water. Immediately call a qualified service technician to inspect the appliance and to replace any part of the control system and any gas control which has been under water.

## OPERATING INSTRUCTIONS

1. **STOP!** Read the safety information above on this label.
2. Set the thermostat to lowest setting.
3. Turn off all electric power to the appliance.
4. This appliance is equipped with an ignition device which automatically lights the burner. Do not try to light the burner by hand.
5. Remove top cover.
6. Turn gas shutoff valve counterclockwise to "OFF". Handle will be perpendicular to pipe. Do not force.
7. Wait five (5) minutes to clear out any gas. If you then smell gas, **STOP!** Follow "B" in the safety information above this label. If you don't smell gas, go to next step.
8. Turn gas shutoff valve clockwise to "ON". Handle will be parallel to pipe.
9. Install top cover.
10. Turn on all electric power to appliance.
11. Set thermostat to desired setting.
12. If the appliance will not operate, follow the instructions "To Turn Off Gas To Appliance" and call your service technician or gas supplier.

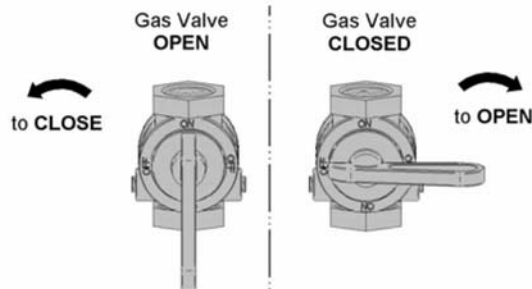

## TO TURN OFF GAS TO APPLIANCE

1. Set the thermostat to lowest setting.
2. Turn off all electric power to the appliance if service is to be performed.
3. Remove top cover.
4. Turn gas shut off valve counterclockwise to "OFF". Handle will be perpendicular to pipe. Do not force
5. Install top cover.

# 10 Start-up

## Check flame and combustion *(continued)*

4. Place the boiler into the active position by pressing the SHUTDOWN button on the display board (FIG. 62, page 59) until **BOILER: Standby** appears in the display window.
5. Locate the pinhole button above the “T” in the Knight logo on the display board (FIG. 62). Press the button once and hold for 5 seconds to place the boiler into Service Mode. In Service Mode the boiler will fire at ignition speed and will then modulate up to full fire.
6. Insert the probe from a combustion analyzer into the hole left by the removal of the flue temperature sensor.
7. Once the boiler has modulated up to full fire, measure the combustion. The values should be in the range listed in Table 8 below. The CO levels should be less than 150 ppm for a properly installed unit.

If the combustion is not within the specified range, reference the Troubleshooting Section of the Knight Boiler Service Manual for possible causes and corrective actions.

**Table 8 Flue Products Chart**

Natural Gas				Propane			
CO <sub>2</sub> min.	CO <sub>2</sub> max.	O <sub>2</sub> min.	O <sub>2</sub> max.	CO <sub>2</sub> min.	CO <sub>2</sub> max.	O <sub>2</sub> min.	O <sub>2</sub> max.
8.0%	10.0%	3.0%	6.5%	8.0%	11.0%	4.0%	8.5%

8. Once the combustion analysis is complete, press the SHUTDOWN button on the display board (FIG. 62) to take the boiler out of Service Mode. The boiler will go to shutdown and the display will show **BOILER: OFF**.
9. Turn the main power off to the boiler and replace the flue temperature sensor into the flue pipe connection.
10. Place the boiler back into normal operation.

### **⚠ WARNING**

You must replace the flue gas temperature sensor to prevent flue gas spillage into the room. Failure to comply could result in severe personal injury, death, or substantial property damage.

## Set space heating operation

### Determine controlling sensor

For space heating systems, the temperature control can be based on one of three sensors; the inlet, outlet, or (optional) system sensor. The SMART SYSTEM control is programmed at the factory to control the temperature of the outlet sensor. The control will automatically switch to the system sensor once it is connected. If it is desired to base the temperature control on the inlet sensor, the appropriate parameter must be changed in the control. See the Knight Boiler Service Manual for a detailed explanation of this procedure.

### Verify space heat circulator mode

The Space Heating Mode controls both the system (primary) pump (if connected), and the boiler (secondary) pump. When the SMART SYSTEM control receives a space heating call for heat, it turns on the system pump. If the boiler is not heating an indirect DHW (Domestic Hot Water) tank, it also turns on the boiler pump. After the space heating call for heat ends, the system pump continues to run for a short period of time. If the boiler pump was running, it continues to run for a short period of time as well. These pump delays are factory set to 30 seconds. If different delays are desired, the appropriate parameters in the control must be changed. See the Knight Boiler Service Manual for a detailed explanation of this procedure.

### Set space heating set point temperature

The UP and DOWN keys may be used during normal operation to adjust the space heating set point temperature. Once the desired temperature is displayed, press the ENTER/RESET key to save the new setting. If the ENTER/RESET key is not pressed, the new setting will be used for the current heating cycle only. The old setting will become active after the current heating cycle ends.

# 10 Start-up *(continued)*

## Set domestic hot water (DHW) operation

### Verify DHW circulator mode

The DHW Mode is programmed to heat an indirect domestic hot water tank. When the tank thermostat calls for heat, the SMART SYSTEM control will turn on the DHW pump and turn off the boiler pump (if running). If the system pump is running, it will remain on. When the DHW call for heat ends, and there is no space heating call for heat, the DHW pump will continue to run for a period of time. This pump delay is set at the factory to 30 seconds. If a shorter or longer delay is desired, the appropriate parameter in the control must be changed. See the Knight Boiler Service Manual for a detailed explanation of this procedure. If there is an active space heating call for heat, then the boiler pump will be turned on and the DHW pump will be turned off.

### Set DHW target temperature

When in the DHW Mode, the control will modulate to maintain the outlet temperature to a set point. This set point is set at the factory to 180°F. If a different set point is desired, the appropriate parameter in the control must be changed. See the Knight Boiler Service Manual for a detailed explanation of this procedure.

### Set clock

The SMART SYSTEM control has a built-in clock that it uses for its night setback feature and for logging events. This clock must be set when the boiler is installed, and anytime the boiler has been powered off for more than one month. Use the following procedure to set the clock:

1. Press and hold the MENU key for a least 5 seconds.
2. The display changes to ready “ENTER MENU CODE”, with four (4) zeros below it.
3. Change the zeros to match the user code (factory set at “0704”). Use the UP and DOWN keys to increment or decrement the flashing digit, and the NEXT and PREVIOUS keys to select which digit flashes.
4. Press the ENTER key.
5. The display changes to read USER CODE for a few seconds, then displays a menu.
6. Press the ENTER key.
7. Press the UP key twice to display “A3 DATE AND TIME”.
8. Press the ENTER key once.

9. The date and time are displayed as “YY:MM:DD W hh:mm”, where:  
mm: minutes  
hh: hour (24 hour time; e.g., 2:00 PM = 14:00)  
W: day of the week (1 = Sunday, 2 = Monday, 3 = Tuesday, etc.,)  
DD: date  
MM: month  
YY: year

Use the UP and DOWN keys to increment or decrement the flashing number, and the NEXT and PREVIOUS keys to select which number flashes.

10. Press the ENTER key to save the setting.
11. Press the MENU key twice to exit the Programming Mode.

# 11 Operating information

## General

### How the boiler operates

The Knight boiler uses an advanced stainless steel heat exchanger and electronic control module that allows fully condensing operation. The blower pulls in air and pushes flue products out of the boiler through the heat exchanger and flue piping. The control module regulates blower speed to control the boiler firing rate. The gas valve senses the amount of air flowing into the boiler and allows only the right amount of gas to flow.

### How the control module operates

The SMART SYSTEM control module receives input from boiler sensors and external inputs. The control module activates and controls the blower and gas valve to regulate heat input and switches the boiler, Domestic Hot Water (DHW), and system pumps on and off as needed. The user programs the module to meet system needs by adjusting control parameters. These parameters set operating temperatures and boiler operating modes. Boiler operation can be based on boiler outlet water temperature, boiler inlet water temperature, or system temperature, depending on the parameter setting.

### Control inputs and outputs

#### Room thermostat / zone control

This input tells the boiler to provide water for space heating.

#### Domestic Hot Water (DHW) tank thermostat

This input tells the boiler to provide water for heating an indirect DHW tank.

#### 0 - 10V input (set point or power)

The Knight boiler can be controlled by a Building Management System (BMS) using a 0 - 10 vdc signal. The control can be configured by the installer to use this signal to either control set point or firing rate.

#### DHW priority

The SMART SYSTEM control module allows connection of a DHW thermostat to the low voltage connection board. When the DHW thermostat calls for heat, the module activates the DHW pump, shuts down the boiler pump, and immediately sets the target outlet water temperature to 180°F. This provides automatic priority heat allocation to the indirect water heater for maximum response and recovery. The DHW pump continues for 30 seconds after the heating cycle to deliver the most possible heat.

#### DHW / space heating (SH) cycling

If a DHW call for heat is received while a space heating call is in progress, the control will start the DHW pump and shut the boiler pump off. The system pump will remain on. If the space heating call is still active while the DHW call is in operation, the control will wait for 30 minutes (time adjustable by installer) then it will switch back to the space heating demand. The control will switch back and forth until one of the heat demands end.

#### Programmable controlling sensor

The control module is programmed to use the outlet sensor as the control sensor by default. If a system sensor is connected, the control automatically uses it as the control sensor. The control sensor can be changed by the installer to the inlet sensor.

#### Anti-cycling

After a space heating demand has been satisfied, the control will delay the next space heating call for a set time period (time is adjustable by the installer). The time delay will be bypassed if the inlet water temperature drops too far during the delay.

#### Boiler, system, and DHW pump control

When a space heating call for heat starts and no DHW call is on, the system and boiler pumps are turned on. As long as the space heating call for heat is on, the system pump will remain on. If a DHW call for heat is on, the boiler pump will wait to turn on until just before the DHW pump turns off. After the space heating call for heat ends, both pumps will run for an additional period of time.

When a DHW call for heat starts, the DHW pump is turned on. If a space heating call for heat was on, the boiler pump will turn off a few seconds after the DHW pump turns on.

### Temperature control

#### Modulation

The Knight boiler is capable of modulating its firing rate from a minimum of 20% to a maximum of 100%. The firing rate is dictated by the call for heat (i.e., space heating or domestic hot water), the heating load, ramp delay (if enabled), and various other temperature limitations.

# 11 Operating information *(continued)*

## Ramp delay

For systems with lower flow, the SMART SYSTEM can limit the firing rate (when enabled) when a space heating call for heat starts, or when switching from a DHW call for heat to a space heating call for heat. There are six (6) limits that can be programmed, as well as six (6) time intervals corresponding to each limit. The sixth limit will also limit the firing rate for the rest of the call for heat.

## Gradient limiting

If during operation of the boiler the outlet water temperature is rising too quickly, the control will reduce the firing rate to its lowest setting.

## Outdoor air reset

With the outdoor air sensor connected, the control module will calculate the set point based on the programmed reset curve. The installer can change the slope of the reset curve by several adjustable parameters. The user can limit the maximum set point for the system using the space heating set point.

## Boost function

If outdoor air reset is active, and a space heating demand has been active continuously for a set period of time (time adjustable by installer) and there has been no DHW demands, the control will increase the set point by a fixed number of degrees (adjustable by installer). This process will continue until the space heating demand ends, the set point reaches the programmed set point, or a maximum of 20 increases has occurred. Once the system heat demand is satisfied, the set point will revert to the value determined by the reset curve.

## Night setback

The controller may be programmed to reduce the space heating set point during a certain time each day. A start and stop time can be programmed for each day of the week.

## Flame current support

To prevent nuisance shutdowns when the boiler is firing at minimum rates, the control will increase fan speed when the flame signal drops too low.

## Protection features

### Outlet temperature, flue temperature, and temperature rise limiting

The outlet temperature is monitored by the boiler outlet temperature sensor. When the outlet temperature exceeds 190°F, the unit will reduce the fan speed. If the outlet water temperature exceeds 193°F the control will shut the unit down until it cools off.

The control module monitors the flue temperature by a sensor located in the flue exhaust. If the flue temperature exceeds 215°F the control will reduce the maximum fan speed. If the flue temperature exceeds 240°F the control will shut the unit down. The unit will restart automatically once the flue temperature drops 25°F and the minimum off time has expired.

The control monitors the temperature difference between the inlet and the outlet sensor. If this difference exceeds 55°F the control will reduce the fan speed. If the temperature difference exceeds 60°F the control will shut the unit down. The unit will restart automatically once the temperature difference has dropped below 55°F and the minimum off time has expired.

### Freeze protection

DO NOT install the boiler in a room likely to freeze.

The following integral feature of the SMART SYSTEM control module provides some protection for the boiler only -- not for the system.

- The SMART SYSTEM control module provides freeze-up protection as follows when the boiler water temperature drops below 45°F:
- Below 45°F, the boiler and system pumps operate constantly.
- Below 37°F, the boiler turns on.
- Boiler and pumps turn off if boiler water temperature rises above 45°F.

### **CAUTION**

This feature of the SMART SYSTEM control module does not eliminate the possibility of freezing. The installation must still use recognized design, installation and maintenance practice to prevent freeze potential for the boiler and system.

# 11 Operating information

## Monitor external limits

Connections are provided on the connection board for external limits such as flow switch, low water cutoff, gas pressure switches, and an auxiliary device proving switch. The SMART SYSTEM will shut off the burner and inhibit relighting whenever any of these external limits open.

## Run-time and alarm outputs

The boiler provides dry contacts for indicating when the boiler is running, and when it is unable to operate.

## Run-time and cycle counting

The control uses two timers to monitor the total hours of burner operation. One timer monitors the time the boiler is firing under 50% of rate. The other timer monitors the time the boiler is firing over 50% rate.

The control uses four (4) ignition counters to monitor the amount of boiler cycles. The first counter counts all ignitions of the control. The second counter counts only ignition attempts that have failed. The third and fourth counters are the same as the first and second respectively, but can be reset by the installer.

## Service reminder

The control can be programmed for service reminder notification. This notification will become active when either a set time frame has expired, or a set amount of running hours or cycles has expired (all adjustable by the installer). The display will alternate the standard text on the display screen with Service Due every 5 seconds. The service reminder notification can be reset by the installer.

## Error logging

The control will hold in memory the last 10 error codes as well as the last 10 turn-off functions. The date and time of the occurrence will be recorded as well. Only the 10 most current occurrences will be held in memory.

## Boiler temperature regulation

### Operating temperature (target)

The SMART SYSTEM control module senses water temperature and regulates boiler firing and firing rate to achieve a target temperature. The target temperature can be set between 70°F and 190°F.

- Target temperature is fixed when the outdoor sensor is not installed.
- Target temperature is calculated as described below under “Outdoor Reset Operation” and “Target Temperature Boost” when the outdoor sensor is connected.

### High limit operations

When outlet temperature exceeds 200°F, high limit action occurs. The boiler shuts down until the outlet water cools down.

If local codes require manual reset, an Adjustable Manual Reset High Limit Kit is available.

### Low water cutoff protection

1. The SMART SYSTEM control module uses temperature sensing of both supply and return areas of the heat exchanger. If the flow rate is too low or either temperature too high, the control module modulates and shuts the boiler down. This ensures boiler shutdown in the event of low water or low flow conditions.
2. Some codes and jurisdiction may accept these integral features of the control in lieu of requiring an additional limit control or low water cutoff. Consult local jurisdiction to determine. A low water cutoff kit(s) is available (Kit 3057).

## Outdoor reset operation, if used

### Target temperature with outdoor reset

This feature improves the system's efficiency as the outdoor temperature warms up.

See Knight Boiler Service Manual to change the settings.

### Reset curve

The reset curve looks at outdoor air temperature and adjusts the set point.



# 11 Operating information *(continued)*

## Sequence of operation

OPERATION	DISPLAY
1. Upon a call for heat, the control turns on the appropriate pumps (system and boiler pumps for space heating call; DHW pump for DHW call).	<b>BLR: Standby</b> <b>OUT: 123.8F (129)</b>
2. The control connects 120 vac to the blower. The blower does not run at this time. <ul style="list-style-type: none"> <li>• If the unit is equipped with a flow switch or low water cutoff, it must close before the control powers up the blower.</li> <li>• If the unit is equipped with a manual reset high limit it must be closed before the control powers up the blower.</li> <li>• If the unit is equipped with a solenoid valve and/or a vent valve, they will be energized along with the blower.</li> <li>• If the unit is equipped with a gas pressure switch, it must close at this time.</li> <li>• If there is an auxiliary device connected to the unit, the unit will then provide 24 vac to its enable relay. If the auxiliary device has a proving switch, it must close before the sequence continues.</li> </ul>	<b>BLR: Standby</b> <b>OUT: 123.8F (129)</b>
3. The control then starts a 10 second prepurge cycle.	<b>BLR: PREPURGE</b> <b>OUT: 123.9F (129)</b>
4. Once the prepurge cycle is complete, and the blocked drain and auto-reset high limit are closed, the control starts the 5 second trial for ignition by sending spark voltage to the spark electrode and opening the gas valve.	<b>BLR: IGNITION</b> <b>OUT: 123.9F (129)</b>
5. If the control does not detect flame by the end of the trial for ignition, the control performs a 10 second postpurge, another prepurge and tries to light the burner again. If the burner does not light after 4 trials (1 trial on the 500 model), the control locks out for 1 hour and then tries another set of 4 trials, except on the 500 model which is 100% lockout.	<b>BLR: POSTPURGE, PREPURGE</b> <b>OUT: 123.9F (129)</b>
6. If the control detects a flame before the trial for ignition ends, it begins to modulate the burner in order to maintain the set point. If the boiler lights due to a space heating call for heat, and the ramp delay function is active (default is active), the modulation will be held to a series of increasing limits after the burner has lit.	<b>BLR: SH 20% RATE</b> <b>OUT: 124.8F (129)</b>
7. If the space heating call for heat is active, and the DHW thermostat closes, the control will turn on the DHW pump, wait 2 seconds, and then turn off the boiler pump. This will divert the hot water away from the heating zone(s) and send it to the DHW tank instead. The control will then modulate to maintain the outlet temperature to the DHW boiler set point.	<b>BLR: DHW 85% RATE</b> <b>OUT: 177.8 (180)</b>

# 11 Operating information

## Sequence of operation *(continued)*

OPERATION	DISPLAY
8. If the DHW thermostat remains on for more than 30 minutes, and the space heating call for heat is also on, then the control will turn on the boiler pump, turn off the DHW pump after 2 seconds, and resume modulating based on the space heating set point. As long as both the space heating and DHW calls for heat remain active, the control will switch back and forth between the two modes until one of them is satisfied.	<b>BLR: SH 41% RATE</b> <b>OUT: 123.0F (129)</b>
9. Once both calls for heat are satisfied, the control will turn off the burner. The blower will remain on for the 10 second postpurge cycle. Any pumps that are running will continue to run for their respective pump delay times, then turn off.	<b>BLR: POSTPURGE</b> <b>OUT: 127.4F (129)</b>
10. Boiler pump off, system pump continues its delay if longer.	<b>BLR: Standby</b> <b>OUT: 124.7F (129)</b>
11. System pump off.	<b>BLR: Standby</b> <b>OUT: 122.9F (129)</b>

# 11 Operating information *(continued)*

## **SMART SYSTEM™** Knight boiler control module

Use the control panel (FIG. 62) to set temperatures, operating conditions, and monitor boiler operation.

Figure 62 Control Panel

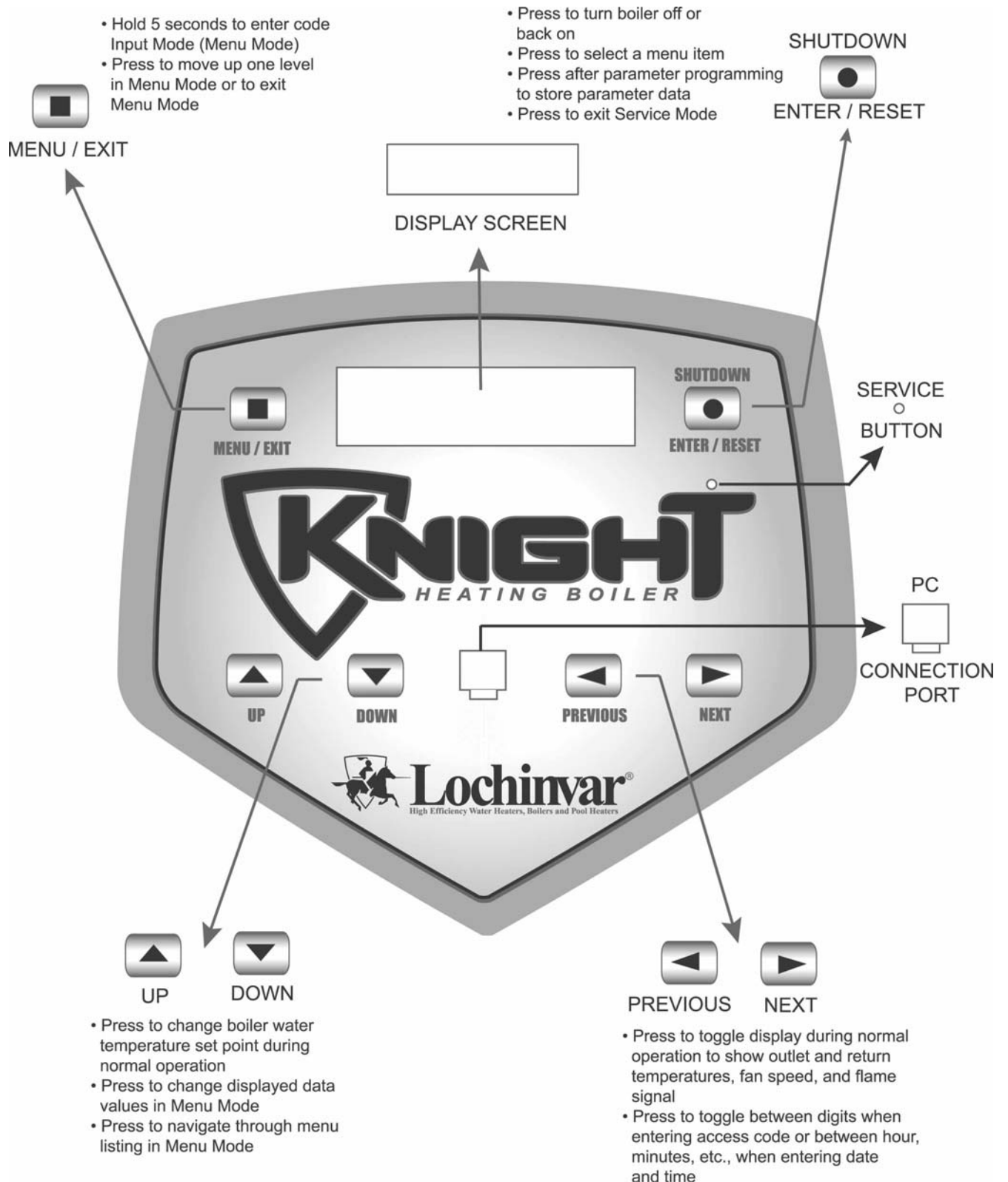

# 11 Operating information

## Access modes

### User

The user can adjust space heating target temperature by using the UP and DOWN buttons (FIG. 62) at any time during normal operation. By entering the USER code (0704), the user can also change temperature units, time and date, and night setback settings. In User Mode, the following parameters can be viewed but not changed:

- Boiler outlet water target temperature in DHW Mode
- Boiler model number
- Software version
- Total operating hours
- Total cycles

### Installer

Most parameters are available only to the installer, accessible only by entering the installer access code, see the Knight Boiler Service Manual.

**Saving parameters** (*reference the Parameter Table in the Knight Boiler Service Manual*)

#### To save parameters and exit programming:

Press the ENTER/RESET button.

#### To keep parameter settings only for a current operating cycle:

Press the MENU/EXIT button 3 times after making all desired parameter changes.

#### To enter a parameter and continue programming:

Press the MENU/EXIT button 1 time to return to the parameter listings; press again to return to the menu listings. Remember to press the ENTER/RESET button when finished programming in order to save the changes made.

See the Knight Boiler Service Manual for a detailed description of parameters and access modes.

# 11 Operating information *(continued)*

Status Display Screens		
By using the Previous/Next (◀, ▶) arrow keys on the SMART SYSTEM display panel, you can navigate through the eight (8) display screens. Each screen will contain two (2) viewable items. The following is a description of the individual items and what they can display:		
Screen	Display shows:	Description
#1	BLR: OFF	The unit has been turned OFF by the Enter/Reset button on the SMART SYSTEM display panel.
	Standby	The unit has not received a call for heat from a remote thermostat nor has it received a call for heat from a DHW thermostat.
	Set Point Met	The unit has met the water temperature set point, but is still receiving a call for heat from either a remote thermostat or a DHW thermostat.
	Prepurge	The unit has initiated a 10 second purge period on a call for heat.
	Ignition	The unit has begun a 5 second spark period to ignite the main burner.
	SH***% Rate	The unit has fired and is running at the displayed percentage.
	Postpurge	The call for heat has been satisfied and the unit runs the fan for an additional 10 seconds to clear the combustion chamber and vent system of residual flue products.
	Service	The unit has been placed in a temporary mode that will allow the unit to fire at 100% of rate for the purpose of combustion analysis.
	OUT: ***.F(***)	When the outlet sensor has been selected as the control sensor (default), the control will display the outlet temperature as well as the set point in parenthesis.
	***.F	If the outlet sensor has not been selected as the control sensor, only the outlet temperature will be displayed.
	Open	The control does not detect the outlet sensor.
Shorted	The outlet sensor wires or the sensor itself has become grounded.	
Press the Next ▶ arrow key on the SMART SYSTEM display to access Screen #2.		
#2	IN: ***.F	If the inlet sensor has not been selected as the control sensor, only the inlet temperature will be displayed.
	***.F (***)	When the inlet sensor has been selected as the control sensor, the control will display the inlet temperature as well as the set point in parenthesis.
	Open	The control does not detect the inlet sensor.
	Shorted	The inlet sensor wires or the sensor itself has become grounded.
	RISE: ***.F	The difference between the inlet temperature and the outlet temperature.
Press the Next ▶ arrow key on the SMART SYSTEM display to access Screen #3.		

# 11 Operating information

## Status Display Screens (cont'd)

By using the Previous/Next (◀, ▶) arrow keys on the SMART SYSTEM display panel, you can navigate through the eight (8) display screens. Each screen will contain two (2) viewable items. The following is a description of the individual items and what they can display:

Screen	Display shows:	Description
#3	SYS: ***.*F	If the system sensor has not been selected as the control sensor, only the system temperature will be displayed.
	***.*F (***)	When the system sensor has been selected as the control sensor, the control will display the system temperature as well as the set point in parenthesis.
	Open	The control does not detect the system sensor.
	Shorted	The system sensor wires or the sensor itself has become grounded.
	OUTDOOR: ***.*F	The control will display the outdoor air temperature as sensed by the outdoor air sensor.
	Open	The control does not detect the outdoor air sensor.
	Shorted	The outdoor air sensor wires or the sensor itself has become grounded.
Press the Next ▶ arrow key on the SMART SYSTEM display to access Screen #4.		
#4	FLUE: ***.*F	The control will display the flue temperature.
	Open	The control does not detect the flue sensor.
	Shorted	The flue sensor wires or the sensor itself has become grounded.
	AUX: ***.*F	The control will display the temperature.
	Open	The control does not detect the auxiliary sensor.
	Shorted	The auxiliary sensor wires or the sensor itself has become grounded.
Press the Next ▶ arrow key on the SMART SYSTEM display to access Screen #5.		
#5	FAN SPD: ****RPM	The control will display the actual fan motor RPM.
	FLAME SIG: **.*uA	The control will display the flame signal in dc microamps.
Press the Next ▶ arrow key on the SMART SYSTEM display to access Screen #6.		
#6	SH CFH: OFF	The control has not received a call for heat from a remote thermostat.
	ON	The control has received a call for heat from a remote thermostat.
	DHW CFH: OFF	The control has not received a call for heat from a SH remote thermostat.
	ON	The control has received a call for heat from a DHW thermostat.
Press the Next ▶ arrow key on the SMART SYSTEM display to access Screen #7.		

# 11 Operating information *(continued)*

## Status Display Screens *(cont'd)*

By using the Previous/Next (◀, ▶) arrow keys on the SMART SYSTEM display panel, you can navigate through the eight (8) display screens. Each screen will contain two (2) viewable items. The following is a description of the individual items and what they can display:

Screen	Display shows:	Description
<b>#7</b>	<b>DHW PUMP: OFF</b>	The control has not received a DHW call for heat and has not powered the DHW pump.
	<b>ON</b>	The control has received a DHW call for heat and has powered the DHW pump.
	<b>Delay</b>	The DHW call for heat has been satisfied and the DHW pump is running for a fixed time to remove any residual heat.
	<b>0-10V IN: **.Vdc</b>	The control will display a 0-10Vdc signal received from a Building Management System (BMS) connected to the unit.

Press the Next ▶ arrow key on the SMART SYSTEM display to access Screen #8.

<b>#8</b>	<b>SYS PUMP: OFF</b>	The control has not received a call for heat from a remote thermostat and has not powered the system pump.
	<b>ON</b>	The control has received a call for heat from a remote thermostat and has powered the system pump.
	<b>Delay</b>	The system call for heat has been satisfied and the system pump is running for a fixed time to remove any residual heat.
	<b>BLR PUMP: OFF</b>	The control has either not received a call for heat from a remote thermostat, a remote thermostat is not connected to the unit and the water temperature has not dropped below the temperature set point of the control to initiate a call for heat, or the control has received a DHW call for heat from a DHW thermostat.
	<b>ON</b>	The control has received a call for heat from a remote thermostat or a remote thermostat is not connected and the water temperature has dropped below the temperature set point of the control to initiate a call for heat.
	<b>Delay</b>	The call for heat has been satisfied and the boiler pump is running for a fixed time to remove any residual heat.

Press the Next ▶ arrow key on the SMART SYSTEM display to roll back to Screen #1. At any point if you wish to access an earlier screen, press the Previous ◀ arrow key on the SMART SYSTEM display.

# 11 Operating information

Figure 63 Wiring Diagram

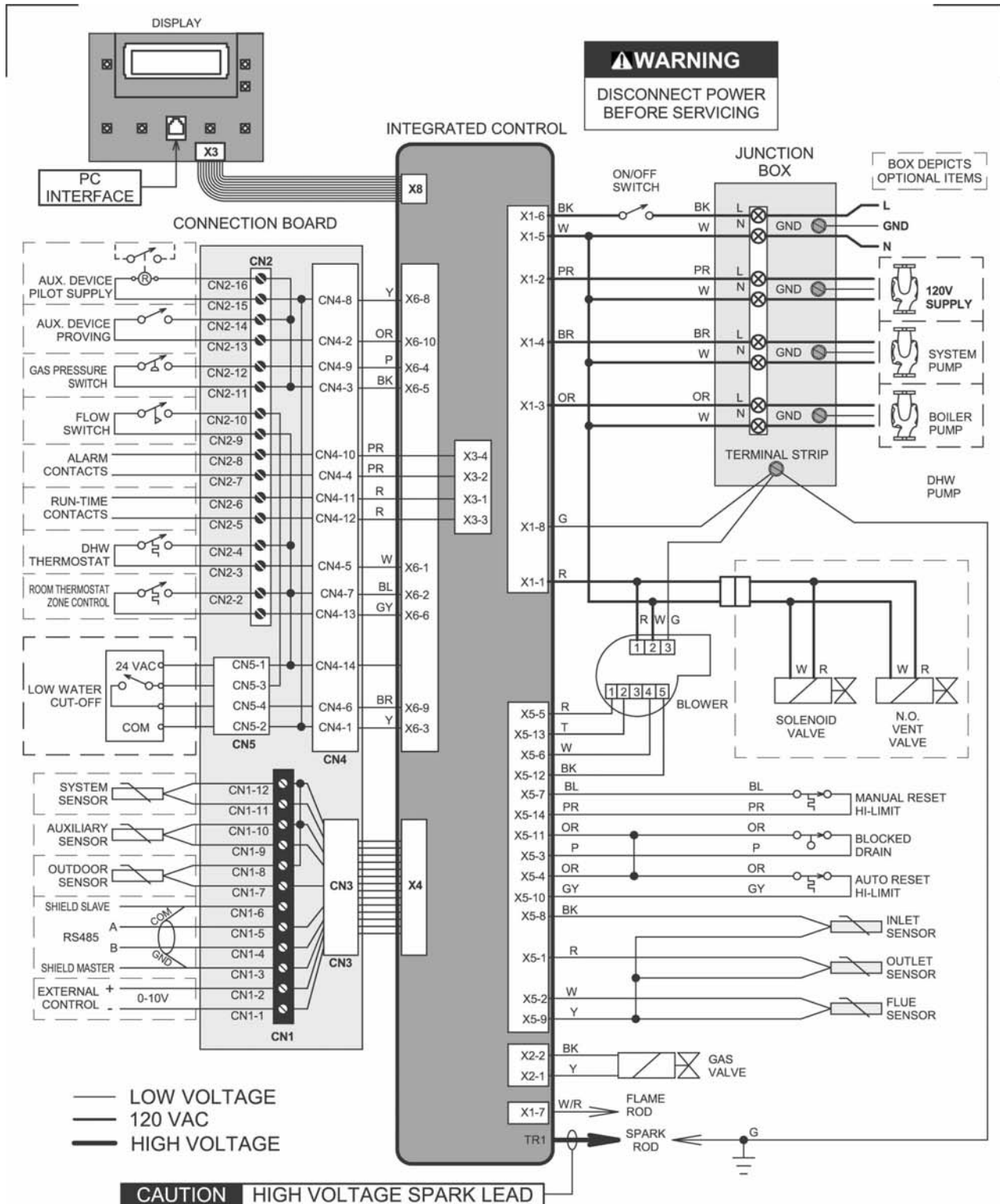



# 11 Operating information *(continued)*

**Figure 64 Ladder Diagram**
