

CLICK ANYWHERE on THIS PAGE to RETURN to
LOCHINVAR HEATER INFORMATION & MANUALS at
InspectApedia.com

COPPER-FIN II[®]

Installation & Operation Manual Models: 402 - 2072

WARNING: If the information in these instructions is not followed exactly, a fire or explosion may result causing property damage, personal injury or death.

- Do not store or use gasoline or other flammable vapors and liquids in the vicinity of this or any other appliance.
- **WHAT TO DO IF YOU SMELL GAS**
 - Do not try to light any appliance.
 - Do not touch any electrical switch; do not use any phone in your building.
 - Immediately call your gas supplier from a near by phone. Follow the gas supplier's instructions.
 - If you cannot reach your gas supplier, call the fire department.
- Installation and service must be performed by a qualified installer, service agency, or the gas supplier.

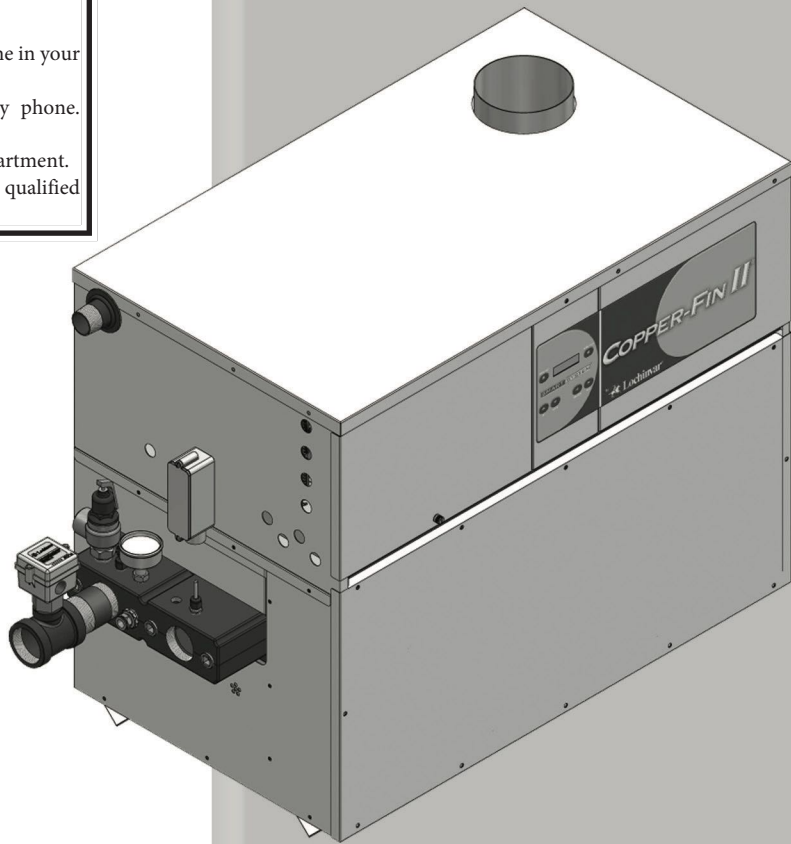

⚠ WARNING:

This manual supplies information for the installation, operation, and servicing of the appliance. It is strongly recommended that this manual and the Copper-fin II Service Manual be reviewed completely before proceeding with an installation. Perform steps in the order given. Failure to comply could result in severe personal injury, death, or substantial property damage.

Save this manual for future reference.

Contents

HAZARD DEFINITIONS.....	2	5. ELECTRICAL CONNECTIONS	
PLEASE READ BEFORE PROCEEDING.....	3	Boiler Operating Control Module.....	43
SAFETY INFORMATION.....	4	Line Voltage Connections.....	44
THE COPPER-FIN II -- HOW IT WORKS.....	5-7	Low Voltage Connections.....	44
RATINGS.....	8	Wiring of the Cascade.....	45
1. DETERMINE UNIT LOCATION		Low Voltage Field Wiring Connections.....	46
Location of Unit.....	9	6. STARTUP	
Recommended Service Clearances.....	9	Check/Control Water Chemistry.....	47
Non-Combustible / Combustible Flooring.....	10	Freeze Protection (when used).....	47
Combustion Air Options.....	10-13	Fill and Test Water System.....	48
2. VENTING		Purge Air from Water System.....	48
Before You Begin.....	13	Check for Gas Leaks.....	48
Vent System Options.....	14	Check Thermostat Circuit(s).....	49
General Venting Information.....	15	Check Vent and Air Piping.....	49
Conventional Negative Draft Venting.....	16-18	Placing the Boiler in Operation.....	49
Vertical DirectAire Venting.....	19-21	Start the Boiler.....	49
Sidewall Venting.....	22-24	If Boiler Does Not Start Correctly.....	49
Horizontal DirectAire Venting.....	25	Set Space heating Operation (boiler only).....	49
Direct Venting.....	26-29	Operating Instructions.....	50
Outdoor Installation.....	30	Set DHW Operation.....	51
3. GAS CONNECTIONS		7. OPERATING INFORMATION	
Connecting to Gas Supply.....	31	General.....	52-54
Gas Pressure Test.....	31	Cascade.....	55-56
Checking Manifold Gas Pressure.....	31	Sequence of Operation.....	57-58
Combination Gas Valves.....	32	Copper-fin II Control Module.....	58
Checking Gas Supply Pressure.....	33	Access Modes.....	59
4. WATER CONNECTIONS		Saving Parameters.....	59
Inlet & Outlet Connections.....	34	Status Display Screens.....	60-63
Relief Valve.....	35	8. DOMESTIC WATER HEATER APPLICATION	
Heating Boiler Installations.....	35-36	Initial Setup of Maximum Water Flow.....	64
Low Temperature Return Water Systems.....	36	Water Chemistry.....	65
Low Temperature Bypass Requirements.....	36	Typical Water Heater Application Piping w/Storage	
Three Way Valves in System.....	37	Tank(s).....	66-67
Radiant Floor and Snow Melt Heating Systems.....	37	Multiple Water Heater Application Piping w/Storage	
Typical Heating Boiler Installations.....	38	Tank(s).....	68-69
Installation with a Chilled Water System.....	38	Pump Operation.....	70
Primary/Secondary Piping of a Single Boiler.....	39	Minimum Water Temperatures (domestic hot water).....	71
Primary/Secondary Piping of Multiple Boilers.....	40	9. MAINTENANCE.....	73-77
Boiler w/Low Temperature Bypass Piping.....	41	10. CONNECTION DIAGRAM.....	78-79
Primary/Secondary Piping with Buffer Tank.....	42	11. LADDER DIAGRAM.....	80-81
		Revision Notes.....	Back Cover

Hazard definitions

The following defined terms are used throughout this manual to bring attention to the presence of hazards of various risk levels or to important information concerning the life of the product.

DANGER

DANGER indicates an imminently hazardous situation which, if not avoided, will result in death or serious injury.

WARNING

WARNING indicates a potentially hazardous situation which, if not avoided, could result in death or serious injury.

CAUTION

CAUTION indicates a potentially hazardous situation which, if not avoided, may result in minor or moderate injury.

CAUTION

CAUTION used without the safety alert symbol indicates a potentially hazardous situation which, if not avoided, may result in property damage.

NOTICE

NOTICE indicates special instructions on installation, operation, or maintenance that are important but not related to personal injury or property damage.

Please read before proceeding

Special instructions

NOTICE

This is a gas appliance and should be installed by a licensed electrician and/or certified gas supplier. Service must be performed by a qualified service installer, service agency or the gas supplier.

WARNING

If the information in these instructions is not followed exactly, a fire or explosion may result causing property damage, personal injury, or death.

This appliance MUST NOT be installed in any location where gasoline or flammable vapors are likely to be present, unless the installation is such to eliminate the probable ignition of gasoline or flammable vapors.

WARNING

Improper installation, adjustment, alteration, service or maintenance can cause injury or property damage. Refer to this manual for assistance or additional information, consult a qualified installer, service agency or the gas supplier.

Checking equipment –

Upon receiving equipment, check for signs of shipping damage. Pay particular attention to parts accompanying the appliances which may show signs of being hit or otherwise being mishandled. Verify total number of pieces shown on packing slip with those actually received. In case there is damage or a shortage, immediately notify the carrier.

Do not use this appliance if any part has been under water. The possible damage to a flooded appliance can be extensive and present numerous safety hazards. Any appliance that has been under water must be replaced.

NOTICE

The ceramic fiber material used in this appliance is an irritant; when handling or replacing the ceramic materials it is advisable that the installer follow these safety guides.

REMOVAL OF COMBUSTION CHAMBER LINING OR BASE PANELS:

- Avoid breathing dust and contact with skin and eyes.
- Use NIOSH certified dust respirator (N95). This type of respirator is based on the OSHA requirements for cristobalite at the time this document was written. Other types of respirators may be needed depending on the job site conditions. Current NIOSH recommendations can be found on the NIOSH website at <http://www.cdc.gov/niosh/homepage.html>. NIOSH approved respirators, manufacturers, and phone numbers are also listed on this website.
- Wear long-sleeved, loose fitting clothing, gloves, and eye protection.

- Apply enough water to the combustion chamber lining to prevent airborne dust.
- Remove the combustion chamber lining from the appliance and place it in a plastic bag for disposal.

- NIOSH stated First Aid:
 - Eye: Irrigate immediately.
 - Breathing: Fresh air.

WARNING

The combustion chamber insulation in this appliance contains ceramic fiber material. Ceramic fibers can be converted to cristobalite in very high temperature applications. The International Agency for Research on Cancer (IARC) has concluded, “Crystalline silica in the form of quartz or cristobalite from occupational sources is carcinogenic to humans (Group 1).” Normal operating temperatures in this appliance are below the level to convert ceramic fibers to cristobalite. Abnormal operating conditions would have to be created to convert the ceramic fibers in this appliance to cristobalite.

The ceramic fiber material used in this appliance is an irritant; when handling or replacing the ceramic materials it is advisable that the installer follow these safety guidelines.

Warranty –

Factory warranty (shipped with unit) does not apply to units improperly installed or improperly operated.

Experience has shown that improper installation or system design, rather than faulty equipment, is the cause of most operating problems.

1. Excessive causing a lime/scale build-up in the copper tube is not the fault of the equipment and is not covered under the manufacturer’s warranty (see Water Treatment and Water Chemistry).
2. Excessive pitting and erosion on the inside of the copper tube may be caused by too much water velocity through the tubes and is not covered by the manufacturer’s warranty (see Boiler Flow Rates and Temperature Rise for flow requirements).

Please read before proceeding

Safety information

⚠ Owner warning –

The information contained in this manual is intended for use by qualified professional installers, service technicians, or gas suppliers.

NOTICE

Consult and follow all local Building and Fire Regulations and other Safety Codes that apply to this installation. Consult local gas utility company to authorize and inspect all gas and flue connections.

A gas appliance that draws combustion air from the equipment room where it is installed must have a supply of fresh air circulating around it during burner operation for proper gas combustion and proper venting.

⚠ WARNING

Should overheating occur or the gas supply fail to shut off, do not turn off or disconnect the electrical supply to the pump. Instead, shut off the gas supply at a location external to the appliance.

Boiler water –

Thoroughly flush the system to remove debris. Use an approved pre-commissioning cleaner (see Start-Up Section), without the boiler connected, to clean the system and remove sediment. The high-efficiency heat exchanger can be damaged by build-up or corrosion due to sediment.

NOTE: Cleaners are designed for either new systems or pre-existing systems. Choose accordingly.

Prevention of freezing –

Heat exchangers and headers damaged by freezing are not covered by warranty.

See Section 7, Operating Information - Freeze Protection for more information.

Codes –

The equipment shall be installed in accordance with those installation regulations in force in the local area where the installation is to be made. These shall be carefully followed in all cases. Authorities having jurisdiction shall be consulted before installations are made. In the absence of such requirements, the installation shall conform to the latest edition of the National Fuel Gas Code, ANSI Z223.1. Where required by the authority having jurisdiction, the installation must conform to American Society of Mechanical Engineers Safety Code for Controls and Safety Devices for Automatically Fired Boilers, ASME CSD-1. All boilers conform to the latest edition of the ASME Boiler and Pressure Vessel Code, Section IV. Where required by the authority having jurisdiction, the installation must comply with the Canadian Gas Association Code, CAN/CGA-B149.1 and/or B149.2 and/or local codes. This appliance meets the safe lighting performance criteria with the gas manifold and control assembly provided, as specified in the ANSI standards for gas-fired hot water boilers, ANSI Z21.13.

⚠ WARNING

To minimize the possibility of serious personal injury, fire or damage to your unit, never violate the following safety rules.

1. This unit is only for use with the type of gas indicated on the rating plate.
2. If you smell gas
 - shut off gas supply
 - do not try to light any appliance
 - do not touch any electrical switch; do not use any phone in your building
 - immediately call your gas supplier from a neighbor's phone. Follow the gas supplier's instructions
 - if you cannot reach your gas supplier, call the fire department
3. Boilers and Hot Water Supply Boilers (HWSB) are heat producing appliances. To avoid damage or injury, do not store materials against the appliance or the vent-air intake system. Use proper care to avoid unnecessary contact (especially children) with the appliance and vent-air intake components.
4. Never cover your unit, lean anything against it, store trash or debris near it, stand on it or in any way block the flow of fresh air to your unit.
5. UNDER NO CIRCUMSTANCES MUST FLAMMABLE MATERIALS SUCH AS GASOLINE OR PAINT THINNER BE USED OR STORED IN THE VICINITY OF THIS APPLIANCE, VENT-AIR INTAKE SYSTEM OR ANY LOCATION FROM WHICH FUMES COULD REACH THE APPLIANCE OR VENT-AIR INTAKE SYSTEM.
6. Appliance surfaces become hot during operation. Be careful not to touch hot surfaces. Keep all adults, children, and animals away from operation of the hot unit. Severe burns can occur.
7. You must take adequate care to prevent scald injury when storing water at elevated temperatures for domestic use.
8. This unit must have an adequate supply of fresh air during operation for proper gas combustion and venting.
9. Make sure all exhaust venting is properly installed and maintained. Improper venting of this unit could lead to increased levels of carbon monoxide.
10. Do not use this boiler if any part has been under water. Immediately call a qualified service technician to replace the boiler. The possible damage to a flooded boiler can be extensive and present numerous safety hazards. Any appliance that has been under water must be replaced.
11. Do not alter this unit in any way. Any change to this unit or its controls can be dangerous.

The Copper-fin II - How it works...

1. **Heat exchanger**
The heat exchanger allows system water to flow through specially designed tubes for maximum heat transfer. The glass lined headers and copper fined tubing are encased in a jacket that contains the combustion process.
2. **Heat exchanger access cover**
The heat exchanger access cover is a galvanized steel door which allows access for service, maintenance, and removal of the heat exchanger from inside the combustion chamber.
3. **Blower**
The blower pulls in and injects air into the individual burners along with gas from the gas manifold where the mix is burned inside the combustion chamber.
4. **Gas valve**
The gas valves (reference) have a dual purpose; changing the gas supply pressure to manifold pressure, and the reference side of the gas valve is designed to allow chamber pressure to change the volume of gas through the valve and measured as net manifold pressure. This is not a design to compensate for gas supply pressure issues.
5. **System / tank temperature sensor (not shown)**
When connected, this sensor can be used as a system sensor or a tank sensor.
6. **Outlet/limit temperature sensor**
This sensor monitors the outlet water temperature. If selected as the controlling sensor and a system supply sensor is not connected, the appliance will maintain set point by adjusting the firing rate of the unit according to this sensor.
7. **Inlet temperature sensor**
This sensor monitors inlet water temperature. If selected as the controlling sensor and a system return sensor is not connected, the appliance will maintain set point by adjusting the firing rate of the unit according to this sensor.
8. **Temperature and pressure gauge (boilers only)**
The temperature and pressure gauge monitors the outlet temperature of the appliance as well as the system water pressure.
9. **Electronic display**
The electronic display consists of 6 buttons and a two-line 16-character liquid crystal display used to monitor the operation of the heater as well as enter and view the programming of the main control board.
10. **Burner**
The burner is a ported stainless steel construction which uses a gas air mix to operate at a fixed input. Banks of burners turn on or off to vary the firing rate.
11. **Water outlet (system supply)**
The water outlet is a 2 or 2 1/2" (depending on model) pipe connection that supplies water to the system with connections for a flow switch (see #26), a relief valve (see #23), and a temperature and pressure gauge (boilers only) (see #8).
12. **Water inlet (system return)**
The water inlet is a 2 or 2 1/2" (depending on model) pipe connection that receives water from the system and delivers it to the heat exchanger.
13. **Gas supply pipe**
The gas supply pipe on this appliance is 1 1/4 or 2" (depending on model) diameter NPT. Please reference the National Fuel Gas Code charts for connection details.
14. **SMART SYSTEM Control Module**
The SMART System Control Module is the main control for the appliance. This module contains the programming that operates the blower, gas valve, and pumps in addition to other programmable features.
15. **Air intake**
Fresh air for combustion is drawn through a filter provided at the air intake, located at either the rear or right side of the appliance.
16. **Line voltage terminal strip**
The line voltage terminal strip provides a location to connect all of the line voltage (120 VAC) contact points to the unit.
17. **Low voltage connection board(s)**
The low voltage connection board provides a location to connect all of the low voltage devices to the appliance. This is where most of the external safety controls are connected.
18. **Front doors - upper and lower**
The front doors provide access to the gas train as well as the blower, burners and other key components for service and maintenance.
19. **Hot surface igniter (HSI)**
The hot surface igniter is a device that is used to ignite the air/gas mixture as well as monitor the performance of the flame during operation. This device acts as a flame sense electrode.
20. **Flame inspection window (sight glass)**
The flame inspection windows, located on either side of the appliance, allow for visual inspection of the burners and flame during operation.
21. **Gas shut off valve (downstream test cock) (boiler only)**
The downstream test cock is provided in the gas train to ensure complete shut off of the gas to the burner in case of maintenance, inspection, or testing of the valve.
22. **Manual reset high limit sensor**
This device monitors the outlet water temperature to ensure safe operation. If the temperature exceeds its setting (field adjustable), it will break the control circuit, shutting the appliance down. Manual reset is performed through the display.
23. **Relief valve**
The relief valve is a safety device that ensures the maximum pressure of the appliance is not exceeded. Boilers operate on pressure only and are shipped from the factory at a rating of 50 PSI. Hot Water Supply Boilers operate on temperature and pressure and are shipped standard as 150 PSI and 210°F (98.9°C).
24. **Power switch**
The power switch is used to engage and disengage power to the appliance on the 120 VAC circuit.
25. **Air pressure switch**
The air pressure switch is a safety device which ensures proper blower operation. The air pressure switch is wired in series with the low voltage control circuit in such a way that if the fan does not engage or shuts down prematurely the device will break the control circuit and the unit will shut down.
26. **Flow switch**
The flow switch is a safety device that ensures flow through the heat exchanger during operation. This appliance is low mass and should never be operated without flow. The flow switch makes contact when flow is detected and allows the unit to operate. If flow is discontinued during operation for any reason the flow switch will break the control circuit and the unit will shut down.
27. **Drain port(s)**
The drain ports are located underneath the front header.
28. **Manual shutoff valve (not shown)**
Manual valve used to isolate the unit from the gas supply.

The Copper-fin II - How it works...

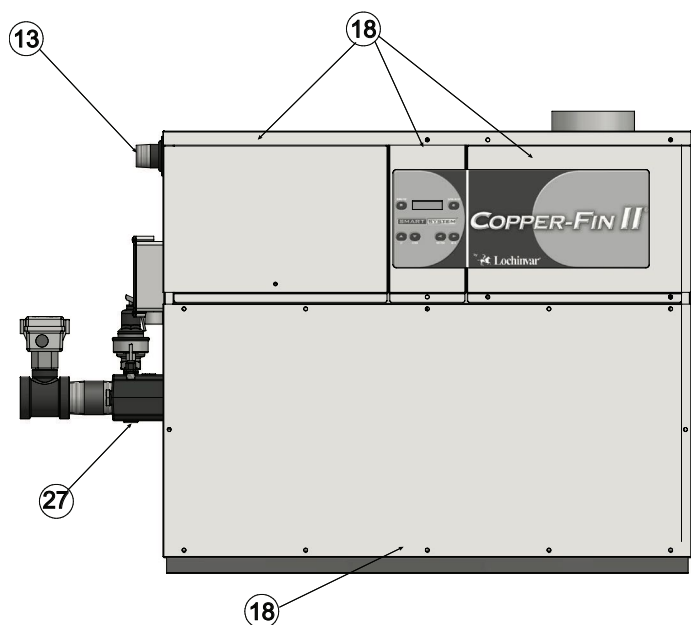

Models 402 - 752 Front View

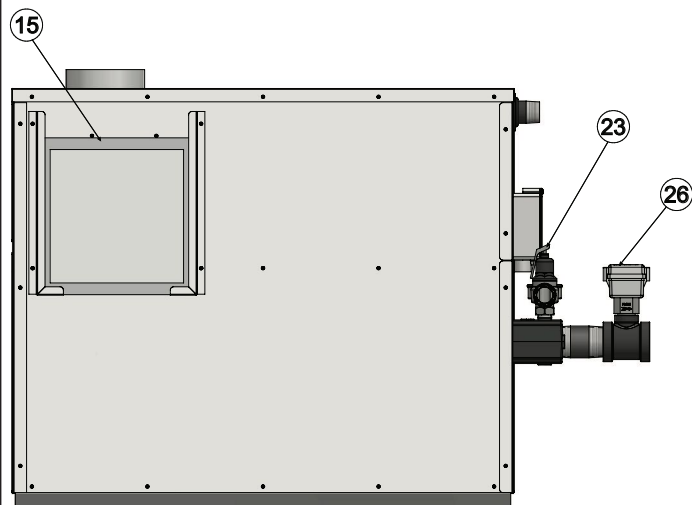

Models 402 - 752 Rear View

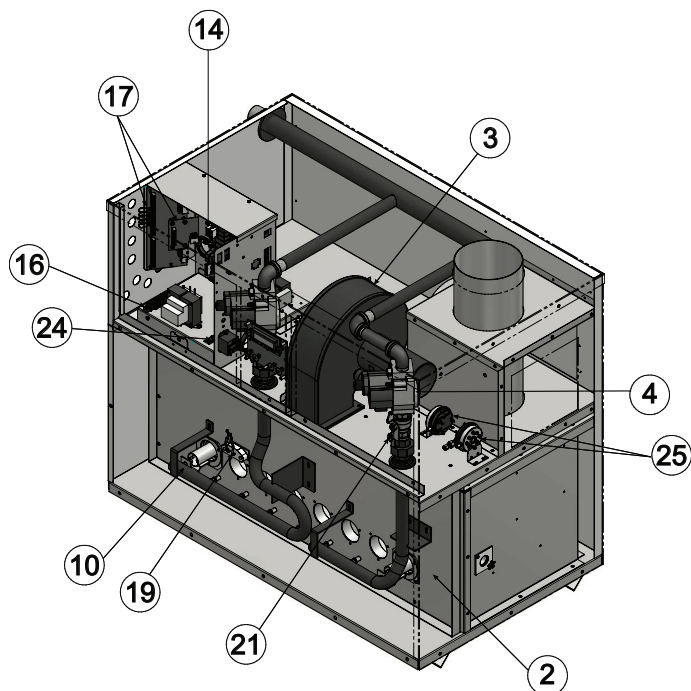

Models 402 - 752 Right Side (inside unit)

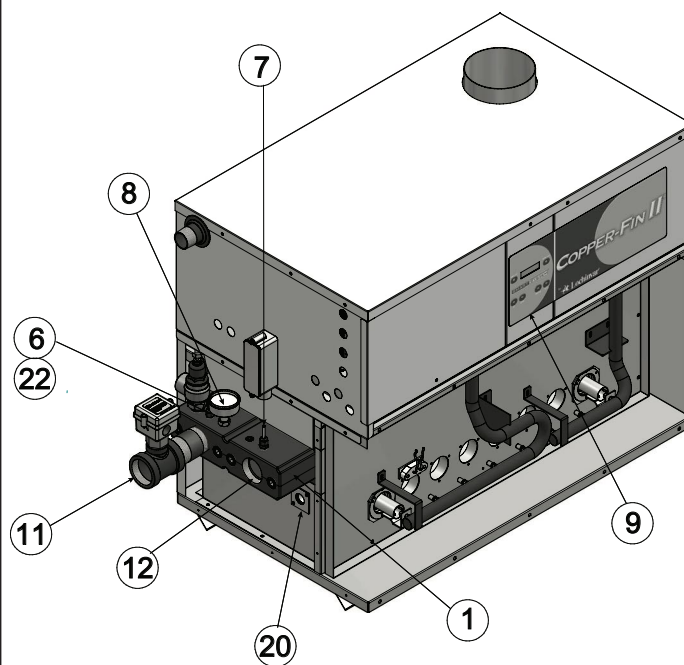

Models 402 - 752 Left Side (inside unit)

The Copper-fin II - How it works... *(continued)*

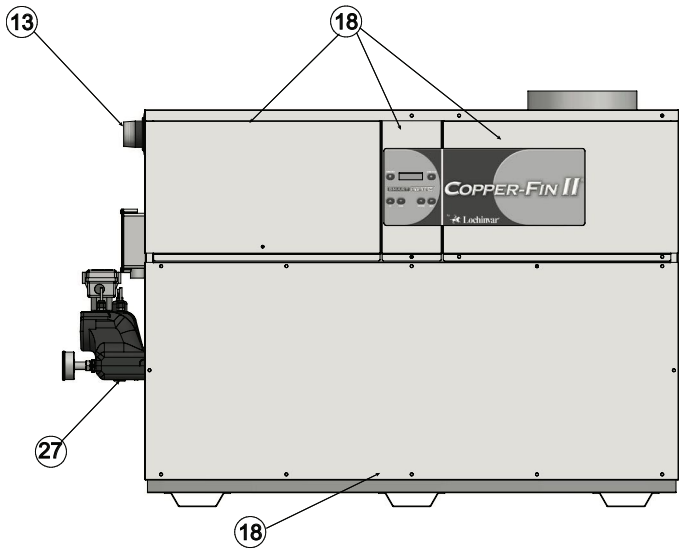

Models 992 - 2072 Front View

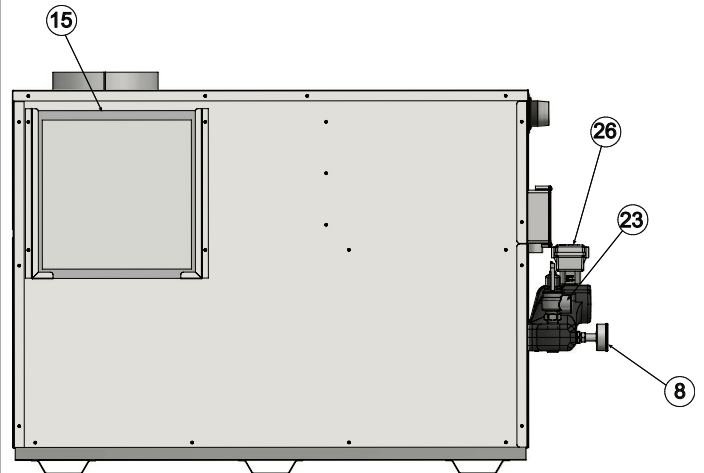

Models 992 - 2072 Rear View

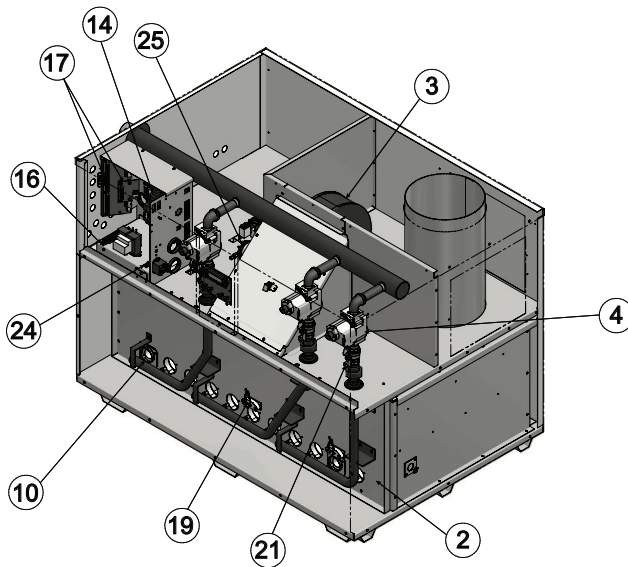

Models 992 - 2072 Right Side (inside unit)

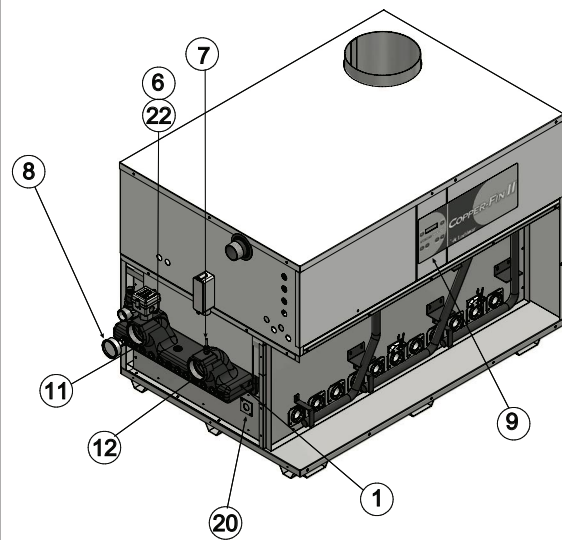

Models 992 - 2072 Left Side (inside unit)

Ratings



LOW LEAD CONTENT



H

Copper-fin II Hot Water Supply Boiler Rating			
Model Number	Input MBH (Note 4)		GPH at 100° Rise
	Min	Max	
CFN0402	250	399	412
CFN0502	250	500	515
CFN0652	250	650	670
CFN0752	250	750	773
CFN0992	360	990	1020
CFN1262	360	1260	1298
CFN1442	360	1440	1484
CFN1802	360	1800	1855
CFN2072	630	2070	2133

Other Specifications			
Appliance Water Content Gallons	Water Connections	Gas Connections	Air / Vent Sizes (Note 3)
1.8	2"	1-1/4"	6"
1.9	2"	1-1/4"	6"
2.0	2"	1-1/4"	8"
2.4	2"	1-1/4"	8"
3.3	2-1/2"	2"	10"
3.5	2-1/2"	2"	12"
3.7	2-1/2"	2"	12"
4.1	2-1/2"	2"	12"/14"
4.3	2-1/2"	2"	12"/14"

Copper-fin II Hot Water Supply Boiler Rating				
Model Number	Input MBH (Note 4)		Gross Output MBH (Note 1)	Net AHRI Ratings Water, MBH (Note 2)
	Min	Max		
CHN0402	250	399	339	295
CHN0502	250	500	425	370
CHN0652	250	650	553	481
CHN0752	250	750	638	555
CHN0992	360	990	842	732
CHN1262	360	1260	1071	931
CHN1442	360	1440	1224	1064
CHN1802	360	1800	1530	1330
CHN2072	630	2070	1760	1530

Other Specifications			
Appliance Water Content Gallons	Water Connections	Gas Connections	Air / Vent Sizes (Note 3)
1.8	2"	1-1/4"	6"
1.9	2"	1-1/4"	6"
2.0	2"	1-1/4"	8"
2.4	2"	1-1/4"	8"
3.3	2-1/2"	2"	10"
3.5	2-1/2"	2"	12"
3.7	2-1/2"	2"	12"
4.1	2-1/2"	2"	12"/14"
4.3	2-1/2"	2"	12"/14"

NOTICE

Maximum allowed working pressure is located on the rating plate.

Notes:

- The ratings are based on standard test procedures prescribed by the United States Department of Energy.
- Net AHRI ratings are based on net installed radiation of sufficient quantity for the requirements of the building and nothing need be added for normal piping and pickup. Ratings are based on a piping and pickup allowance of 1.15.
- Copper-fin II's require special gas venting. Use only the vent materials and methods specified in the Copper-fin II Installation and Operation Manual.
- The Copper-fin II is orificed for operation up to 2000 feet altitude, and including up to 4,500 feet, with no field adjustments. The appliance will de-rate by 4% for each 1000 feet above sea level up to 4,500 feet. Consult the factory for installations above 4,500 feet elevation.

1 Determine unit location

Location of unit

This unit meets the safe lighting performance criteria with the gas manifold and control assembly provided, as specified in the ANSI standards for gas-fired units, ANSI Z21.13/CSA 4.9 - latest edition.

- Maintain all clearances from combustible construction when locating appliance. See Clearances from Combustible Construction, this page.
- Locate the appliance so that if water connections should leak, water damage will not occur. When such locations cannot be avoided, it is recommended that a suitable drain pan, adequately drained, be installed under the unit. The pan must not restrict combustion airflow. Under no circumstances is the manufacturer to be held responsible for water damage in connection with this unit, or any of its components.
- The appliance must be installed so that the ignition system components are protected from water (dripping, spraying, rain, etc.) during appliance operation and service (circulator replacement, control replacement, etc.).
- Appliances located in a residential garage and in adjacent spaces that open to the garage and are not part of the living space of a dwelling unit must be installed so that all burners and burner ignition devices have a minimum clearance of not less than 18" (46 cm) above the floor. The appliance must be located or protected so that it is not subject to physical damage by a moving vehicle.
- DO NOT** install this appliance in any location where gasoline or flammable vapors are likely to be present.
- The appliance must be installed on a level floor.
- Combustible floor installation:
 - Models 402 - 752 **require** an approved floor kit for installation on combustible flooring (reference Table 1A).
 - Models 992 - 2072 are approved for installation on combustible flooring without a floor kit. **Note:** Concrete block over wood flooring is not considered non-combustible.
- DO NOT** install this appliance directly on carpeting or other combustible material.
- Maintain required clearances from combustible surfaces, reference the *Indoor Clearances from Combustible Construction Section*, this page.
- For outdoor models, you must install an optional vent cap. Instructions for mounting the vent cap are included in the venting section of this manual. Do not install outdoor models directly on the ground. You must install the outdoor unit on a concrete, brick, block, or other non-combustible pad. Outdoor models have additional special location and clearance requirements. See Outdoor Installation Venting, page 30. A wind proof cabinet protects the unit from weather.

Indoor clearances from combustible construction

Maintain minimum specified clearances for adequate operation. Allow sufficient space for servicing pipe connections, pump and other auxiliary equipment, as well as the unit. See rating plate for specific service clearance requirements.

Right Side	3" (7.5 cm)
Rear	3" (7.5 cm) (3" min. from any surface)*
Left Side	6" (15 cm) (24" (0.61 m) suggested for service)
Front	Alcove* (30" (0.76m) suggested for service)
Top	3" (7.5 cm)
Flue	1" (25.4 mm)
Hot Water Pipes	1" (25.4 mm)

*An Alcove is a closet without a door. Thirty-six inches (36") to rear required for outdoor installation.

Note: No additional clearance is needed on the right side of the unit for the observation port. An observation port is located on both the right and left side of the unit.

Figure 1-1 Indoor clearances from combustible construction

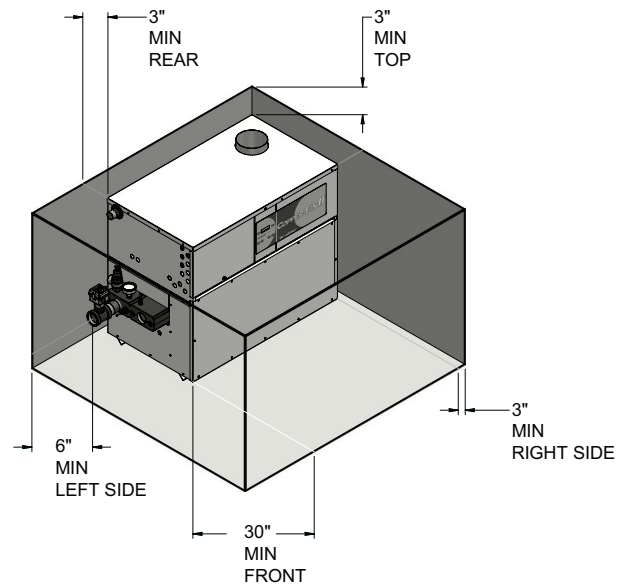

NOTICE

Clearances from combustible construction are noted on the appliance rating plate.

TABLE - 1A
COMBUSTIBLE FLOOR KITS

Model	Kit Number
402	100136976
502	100136977
652	100136978
752	100136979

Freeze protection

Although these units are CSA International design-certified for outdoor installations, such installations are not recommended in areas where the danger of freezing exists. You must provide proper freeze protection for outdoor installations, units installed in unheated mechanical rooms or where temperatures may drop to the freezing point or lower. If freeze protection is not provided for the system, a low ambient temperature alarm is recommended for the mechanical room. Damage to the unit by freezing is non-warrantable.

1 Determine unit location

Anytime the inlet temperature drops below 45°F, the control turns on the pump contact. If the inlet temperature is below 37°F, and the unit is in the ON Mode, the first stage will fire.

Location

Locate indoor boilers and hot water supply boilers in a room having a temperature safely above freezing [32°F (0°C)].

CAUTION A mechanical room operating under a negative draft pressure may experience a down draft in the flue of a boiler when it is not firing. The cold outside air pulled down the flue may freeze a heat exchanger. This condition must be corrected to provide adequate freeze protection.

Hydronic systems anti-freeze

Freeze protection for a heating boiler or hot water supply boiler using an indirect coil can be provided by using hydronic system antifreeze. Follow the appliance manufacturers instructions. Do not use undiluted or automotive type antifreeze (see page 47).

Outdoor boiler installation

Adequate hydronic system antifreeze must be used. A snow screen should be installed to prevent snow and ice accumulation around the unit or its venting system.

Combustion and ventilation air

Provisions for combustion and ventilation air must be in accordance with Air for Combustion and Ventilation, of the latest edition of the National Fuel Gas Code, ANSI Z223.1, in Canada, the latest edition of CAN/CGA-B149 Installation Code for Gas Burning Appliances and Equipment, or applicable provisions of the local building codes.

Provide properly-sized openings to the equipment room to assure adequate combustion air and proper ventilation when the unit is installed with conventional venting or sidewall venting.

Combustion air options

CAUTION Under no circumstances should the equipment room ever be under a negative pressure. Particular care should be taken where exhaust fans, attic fans, clothes dryers, compressors, air handling units, etc., may take away air from the unit.

This unit has four combustion air options.

1. Outside Combustion Air, No Ducts

You can direct outside combustion air to this unit using either one or two permanent openings (see FIG. 1-2).

One Opening

The opening must have a minimum free area of one square inch per 3000 Btu input (7 cm² per kW). You must locate this opening within 12" (30 cm) of the top of the enclosure.

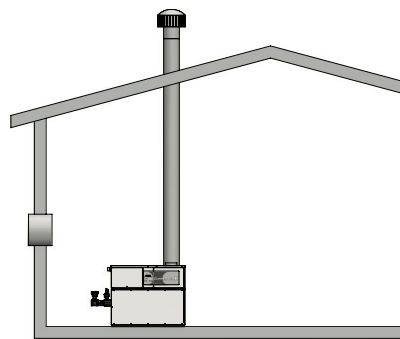

Figure 1-2_ Outside Combustion Air - Single Opening
Two Openings

The combustion air opening must have a minimum free area of one square inch per 4000 Btu/hr input (5.5 cm² per kW). You must locate this opening within 12" (30 cm) of the bottom of the enclosure (see FIG. 1-3).

The ventilation air opening must have a minimum free area of one square inch per 4000 Btu/hr input (5.5 cm² per kW). You must locate this opening within 12" (30 cm) of the top of the enclosure.

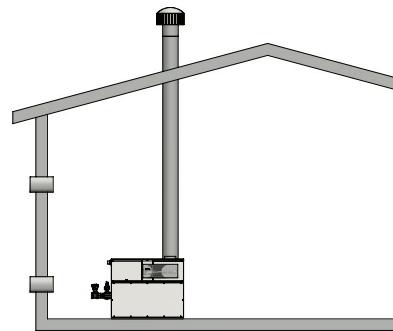

Figure 1-3_ Outside Combustion Air - Two Openings

2. Outside Combustion Air, Using Ducts

You can direct outside combustion air to this unit using two air ducts to deliver the air to the boiler room (see FIG. 1-5).

Each of the two openings must have a minimum free area of one square inch per 2000 Btu input (11cm² per kW).

3. Combustion Air from Interior Space

You can direct combustion air to this unit using air from an adjoining interior space. You must provide two openings from the boiler room to the adjoining room (see FIG. 1-4).

Each of the two openings must have a net free area of one square inch per 1000 Btu input (22cm² per kW), but not less than 100 square inches (645cm²).

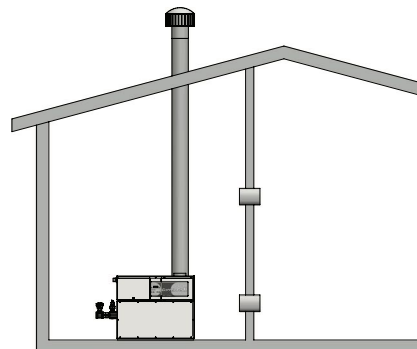

Figure 1-4_ Combustion Air from Interior Space

1 Determine unit location *(continued)*

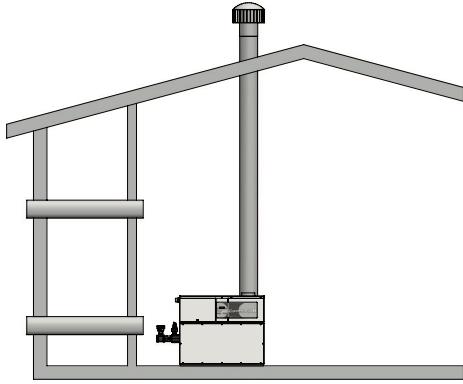

Figure 1-5_ Outside Combustion Air Through Ducts

4. Outside Combustion Air - Using Direct Venting

With this option, you can connect combustion air vent piping directly to the unit. See the information under Direct Venting starting on page 26 for specific information regarding this option.

All dimensions are based on net free area in square inches. Metal louvers or screens reduce the free area of a combustion air opening a minimum of approximately 25%. Check with louver manufacturers for exact net free area of louvers. Where two openings are provided, one must be within 12" (30 cm) of the ceiling and one must be within 12" (30 cm) of the floor of the equipment room. Each opening must have a minimum net free area as specified in TABLE 1C, page 11. Single openings shall be installed within 12" (30 cm) of the ceiling.

CAUTION The combustion air supply must be completely free of any flammable vapors that may ignite or chemical fumes which may be corrosive to the appliance. Common corrosive chemical fumes which must be avoided are fluorocarbons and other halogenated compounds, most commonly present as refrigerants or solvents, such as Freon, trichlorethylene, perchlorethylene, chlorine, etc. These chemicals, when burned, form acids which quickly attack the heat exchanger finned tubes, headers, flue collectors, and the vent system. The result is improper combustion and a non-warrantable, premature unit failure.

TABLE - 1C
MINIMUM RECOMMENDED COMBUSTION
AIR SUPPLY TO EQUIPMENT ROOM

Model Number	*Outside Air from 2 Openings Directly from Outdoors		*Outside Air from 1 Opening Directly from Outdoors, in ²	Inside Air from 2 Ducts Delivered from Outdoors		Inside Air from 2 Ducts Delivered from Interior Space	
	Top Opening, in ²	Bottom Opening, in ²		Top Opening, in ²	Bottom Opening, in ²	Top Opening, in ²	Bottom Opening, in ²
402	100 (645 cm ²)	100 (645 cm ²)	133 (858 cm ²)	200 (1291 cm ²)	200 (1291 cm ²)	400 (2581 cm ²)	400 (2581 cm ²)
502	125 (806 cm ²)	125 (806 cm ²)	167 (1077 cm ²)	250 (1613 cm ²)	250 (1613 cm ²)	500 (3226 cm ²)	500 (3226 cm ²)
652	163 (1052 cm ²)	163 (1052 cm ²)	217 (1400 cm ²)	325 (2097 cm ²)	325 (2097 cm ²)	650 (4194 cm ²)	650 (4194 cm ²)
752	188 (1213 cm ²)	188 (1213 cm ²)	250 (1613 cm ²)	375 (2420 cm ²)	375 (2420 cm ²)	750 (4839 cm ²)	750 (4839 cm ²)
992	248 (1600 cm ²)	248 (1600 cm ²)	330 (2129 cm ²)	495 (3194 cm ²)	495 (3194 cm ²)	990 (6388 cm ²)	990 (6388 cm ²)
1262	315 (2032cm ²)	315 (2032cm ²)	420 (2710 cm ²)	630 (4065 cm ²)	630 (4065 cm ²)	1260 (8130 cm ²)	1260 (8130 cm ²)
1442	360 (2323cm ²)	360 (2323cm ²)	480 (3097 cm ²)	720 (4646 cm ²)	720 (4646 cm ²)	1440 (9291 cm ²)	1440 (9291 cm ²)
1802	450 (2903cm ²)	450 (2903cm ²)	600 (3871 cm ²)	900 (5807 cm ²)	900 (5807 cm ²)	1800 (11614 cm ²)	1800 (11614 cm ²)
2072	518 (3342cm ²)	518 (3342cm ²)	690 (4452 cm ²)	1035 (6678 cm ²)	1035 (6678 cm ²)	2070 (13356 cm ²)	2070 (13356 cm ²)

*Outside air openings shall directly communicate with the outdoors. When combustion air is drawn from the outside through a duct, the net free area of each of the two openings must have twice (2 times) the free area required for Outside Air/2 Openings. The above requirements are for the boiler only; additional gas fired appliances in the equipment room will require an increase in the net free area to supply adequate combustion air for all appliances.

1 Determine unit location

Exhaust fans

Any fan or equipment which exhausts air from the boiler room may deplete the combustion air supply and/or cause a down draft in the venting system. Spillage of flue products from the venting system into an occupied living space can cause a very hazardous condition that must be immediately corrected. If a fan is used to supply combustion air to the boiler room, the installer must make sure that it does not cause drafts which could lead to nuisance operational problems with the boiler.

Vertical DirectAire™, Horizontal DirectAire™, and Direct Vent venting systems have specific requirements for combustion air ducts from the outside which are directly connected to the unit. See the requirements for combustion air duct in the venting section.

NOTICE

Use of filters having MERV (*Minimum Efficiency Reporting Value*) ratings higher than 4 is not recommended. Higher efficiency low-micron filters can limit combustion air leading to either nuisance problems or potential component damage if used over prolonged periods of time. Filters having a MERV rating of 5 to 6 may be used on a limited basis during the construction phase of a project provided they are replaced once filter loading becomes apparent. After the construction phase is completed, it is recommended that the filter be changed to a 4 or lower MERV disposable type filter.

Combustion air filter

This unit has a standard air filter located at the combustion air inlet. This filter helps ensure clean air is used for the combustion process. Check this filter every month and replace when it becomes dirty. The filter size on Models 402 - 752 is 12" x 12" x 1" (30.5cm x 30.5cm x 2.5cm) and 16" x 16" x 1" (40.6cm x 40.6cm x 2.5 cm) on Models 992 - 2072. You can find these commercially available filters at any home center or HVAC supply store.

For convenience and flexibility, you can direct the combustion air inlet from either the back or right side of the unit. To arrange the combustion air inlet for side entry, follow the steps below:

1. Remove the metal panel from the unit's side wall (see FIG. 1-6).
2. Remove screws from the air filter/bracket assembly.
3. Move the filter/bracket assembly from the rear of unit to the side opening (see FIG. 1-7).
4. Attach filter/bracket assembly to the unit's side using the pre-drilled screw holes.
5. Attach the metal panel to the rear combustion air opening to seal it off.

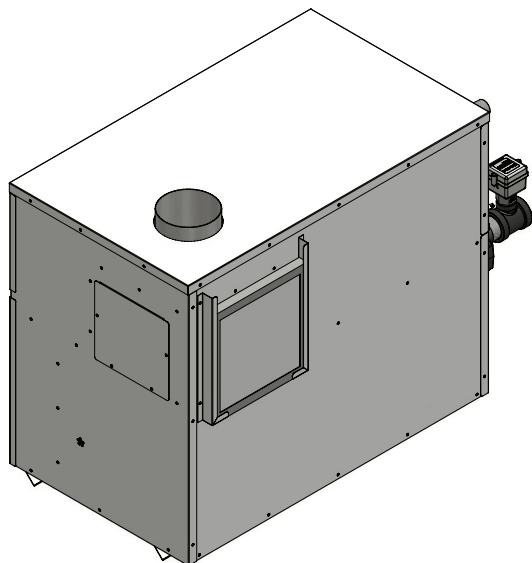

Figure 1-6 Metal Panel Covering Side Combustion Air Inlet

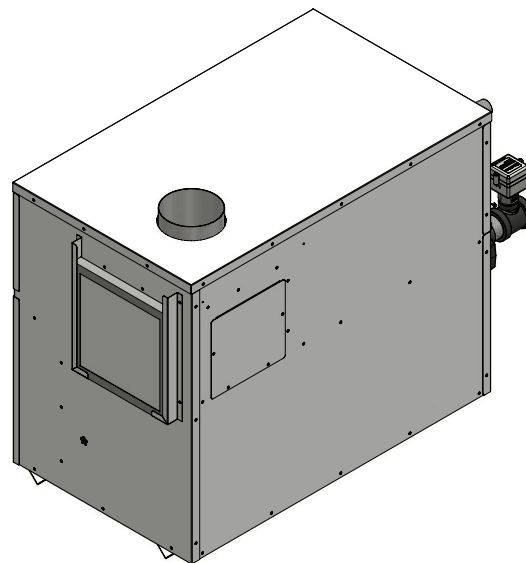

Figure 1-7 Moving Air Filter / Bracket Assembly from Rear of Unit to Side

NOTICE

During construction the air filter should be checked more frequently to ensure it does not become clogged with combustion dirt and debris.

CAUTION

Sustained operation of an appliance with a clogged filter may result in nuisance operational problems, bad combustion, and non-warrantable component failures.

2 Venting

BEFORE YOU BEGIN

Identify your appliance's vent system:

This manual covers venting requirements for CAT I models and CAT IV vent materials. Be sure to correctly identify the type of vent system your appliance requires before proceeding.

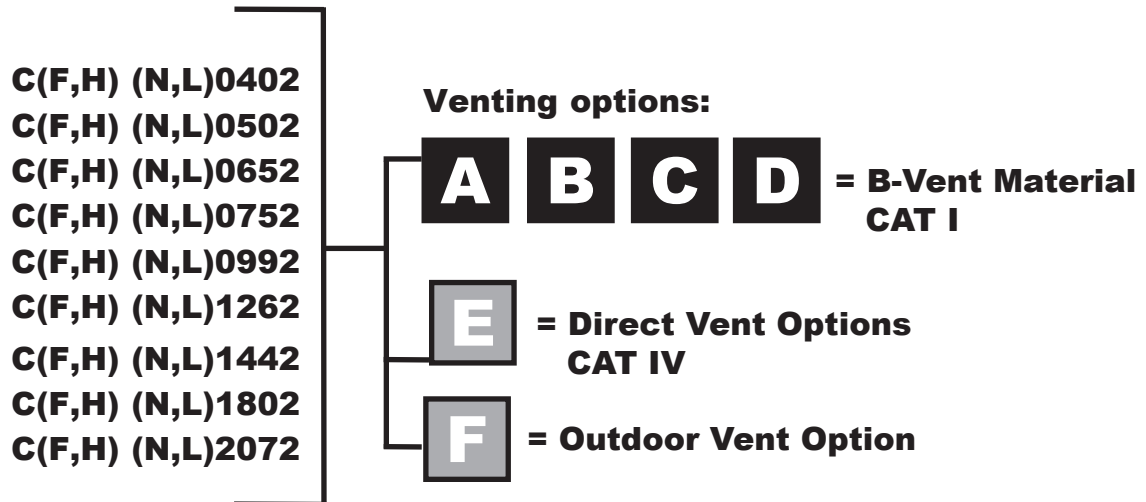

⚠ DANGER

Failure to use correct venting materials can result in loss of life from flue gas spillage into working or living space.

Venting Category Definitions: (Reference National Fuel Gas Code ANSI Z223.1)

CAT I: Negative pressure non-condensing

An appliance that operates with a non-positive vent static pressure with a vent gas temperature that avoids excessive condensate production in the vent.

CAT IV: Positive pressure condensing

An appliance that operates with a positive vent static pressure with a vent gas temperature that may cause excessive condensate production in the vent.

CAT IV Flue pipe materials

The following manufacturers supply flue materials suitable for these models when installed as CAT IV. All materials are made with AL29-4C stainless steel.

Heat-Fab Inc., Saf-T CI Vent with AL29-4C stainless steel

Protech Systems Inc., Fas N Seal Vent with AL29-4C stainless steel

Metal-Fab Inc., Corr/Guard Vent with AL29-4C stainless steel

Or other listed Category IV vent systems suitable for a condensing, positive pressure, gas fired appliance.

A Category IV flue **MUST** have all vent joints and seams sealed gastight and have provisions for a drain to properly collect and dispose of condensate that may occur in the venting system.

2 Venting

Vent system options: (Note: Installations shown below are representative, actual installations may vary from those shown.)

A

This option uses a vertical rooftop flue termination with air supplied from the equipment room - see page 16.

CONVENTIONAL NEGATIVE DRAFT VENTING

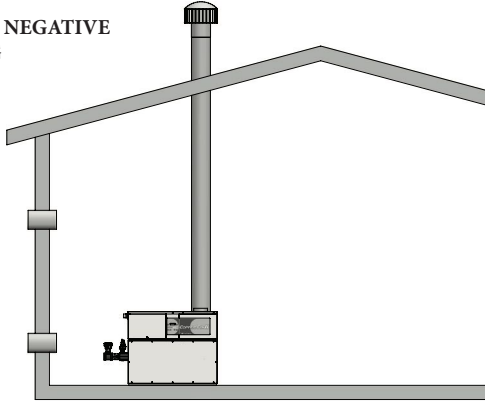

D

This option uses a powered vent assembly to exhaust the flue products out a sidewall with air supplied by a pipe from the sidewall - see page 25.

HORIZONTAL DIRECTAIRE VENTING

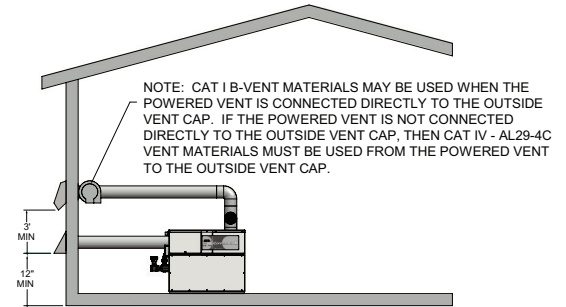

B

This option uses a vertical conventional vent for flue products with air supplied by a pipe from the sidewall or rooftop - see page 19.

VERTICAL DIRECTAIRE VENTING

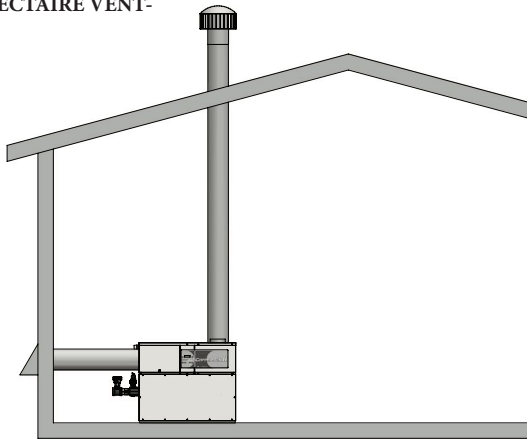

E

This option uses a sealed AL29-4C flue and a separate combustion air pipe to the outdoors. This system terminates both the flue and combustion air inlet in the same pressure zone - see page 26.

DIRECT VENT - see page 26.

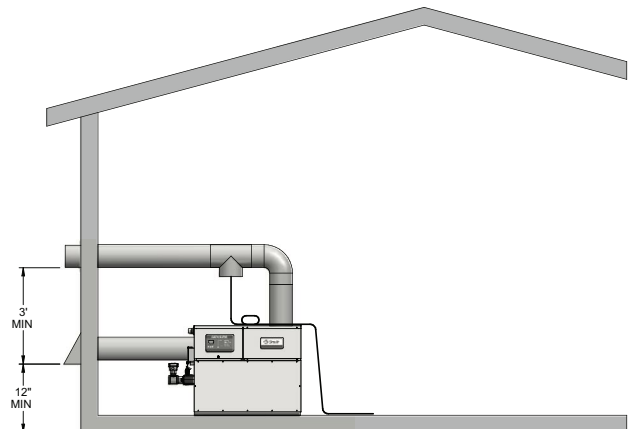

C

This option uses a powered vent assembly to exhaust the flue products out a sidewall vent termination with air supplied from the equipment room - see page 22.

SIDEWALL VENTING

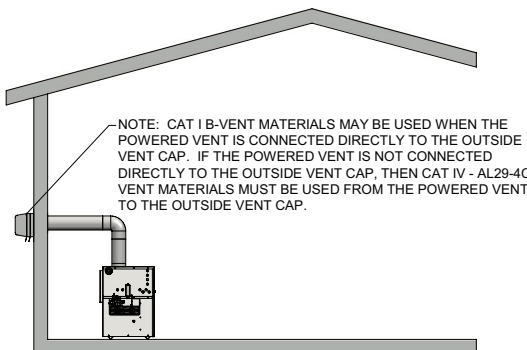

F

This option uses the installation of a special air inlet / vent cap on top of the unit - see page 30.

OUTDOOR VENTING

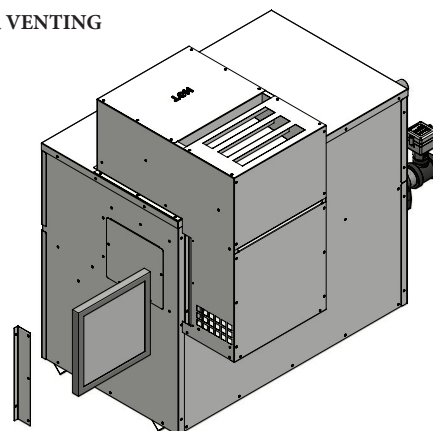

2 Venting *(continued)*

General information

You must supply adequate combustion and ventilation air to this unit. You must provide minimum clearances for the vent terminal from adjacent buildings, windows that open, and building openings. Follow all requirements set forth in the latest edition of the National Fuel Gas Code, ANSI Z223.1, in Canada, the latest edition of CAN/CGA Standard B149 Installation Code for Gas Burning Appliances and Equipment or applicable local building codes. Vent installations for connection to gas vents or chimneys must be in accordance with "Venting of Equipment" of the above-mentioned standards.

NOTICE

Examine the venting system at least once each year. Check all joints and vent pipe connections for tightness. Also check for corrosion or deterioration. If you find any problems, correct them at once.

Venting support

Support horizontal portions of the venting system to prevent sagging. Provide an upward slope of at least 1/4 inch per foot (21mm/m) on all horizontal runs from the unit to the vertical flue run or to the vent terminal on sidewall venting installations.

Do not use an existing chimney as a raceway if another appliance or fireplace is vented through the chimney. The weight of the venting system must not rest on the unit. Provide adequate support of the venting system. Follow all local and applicable codes. Secure and seal all vent connections. Follow the installation instructions from the vent material manufacturer.

Barometric damper location

Any venting system option that requires a barometric damper must adhere to the following directions for optimum performance. The preferred location for the barometric damper is in a tee or collar installed in the vertical pipe rising from the unit's flue outlet. The barometric damper **MUST NOT** be installed in a bull head tee installed on the unit's flue outlet. The tee or collar containing the barometric damper should be approximately three feet vertically above the connection to the unit's flue outlet. This location ensures that any positive velocity pressure from the unit's internal combustion fan is dissipated and the flue products are rising due to buoyancy generated from the temperature of the flue products. Adjust the weights on the damper to ensure that draft is maintained within the specified range.

TABLE - 2A
FLUE AND AIR INLET PIPE SIZES

MODEL	FLUE SIZE	AIR INLET SIZE	MODEL	FLUE SIZE	AIR INLET SIZE*
402	6"	6"	992	10"	10"
502	6"	6"	1262	12"	12"
652	8"	8"	1442	12"	12"
752	8"	8"	1802	14"	12"
--	--	--	2072	14"	12"

*Minimum diameter for air inlet pipe. Installer may increase diameter one pipe size for ease of installation, if needed.

2 Venting

A

Conventional negative draft venting - see page 14.

NOTICE

Before installing a venting system, follow requirements found in the General Venting section.

This option uses Type-B double-wall flue outlet piping. The blower brings in combustion air. The buoyancy of the heated flue products cause them to rise up through the flue pipe. The flue outlet terminates at the rooftop.

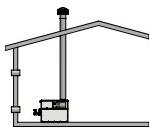

Negative draft

The negative draft in a conventional vent installation must be within the range of 0.02 to 0.08 inches w.c. to ensure proper operation. Make all draft readings while the unit is in stable operation (approximately 2 to 5 minutes).

Connect the flue vent directly to the flue outlet opening on the top of the unit. No additional draft diverter or barometric damper is needed on single unit installations with a dedicated stack and a negative draft within the specified range of 0.02 to 0.08 inches w.c. If the draft in a dedicated stack for a single unit installation exceeds the maximum specified draft, you must install a barometric damper to control draft. Multiple unit installations with combined venting or common venting with other Category I negative draft appliances require each boiler to have a barometric damper installed to regulate draft within the proper range.

Do not connect vent connectors serving appliances vented by natural draft (negative draft) to any portion of a mechanical draft system operating under positive pressure. Connecting to a positive pressure stack may cause flue products to be discharged into the living space causing serious health injury.

Flue outlet piping

With this venting option, you must use Type-B double-wall vent materials. Vent materials must be listed by a nationally-recognized test agency for use as vent materials. Make the connections from the unit vent to the outside stack as direct as possible with no reduction in diameter. Use the National Fuel Gas Code venting tables for double-wall vent to properly size all vent connectors and stacks. Follow the vent manufacturer's instructions when installing Type-B vents and accessories, such as firestop spacers, vent connectors, thimbles, caps, etc.

Provide adequate clearance to combustibles for the vent connector and firestop.

When planning the venting system, avoid possible contact with plumbing or electrical wiring inside walls, ceilings, and floors. Locate the unit as close as possible to a chimney or gas vent.

Avoid long horizontal runs of the vent pipe, 90° elbows, reductions and restrictions.

No additional draft diverter or barometric damper is required on single unit installations with a dedicated stack and a negative draft maintained between 0.02 to 0.08 inches w.c.

Common Venting Systems

You can combine the flue with the vent from any other negative draft, Category I appliance. Using common venting for multiple negative draft appliances requires you to install a barometric damper with each unit. This will regulate draft within the proper range. You must size the common vent and connectors from multiple units per the venting tables for Type-B double-wall vents in the latest edition of the National Fuel Gas Code, ANSI Z223.1 and/or CAN/CGA-B149 Installation Code.

Common venting systems may be too large when an existing unit is removed.

At the time of removal of an existing appliance, the following steps shall be followed with each appliance remaining connected to the common venting system placed in operation, while other appliances remaining connected to the common venting system are not in operation.

1. Seal any unused opening in the common venting system.
2. Visually inspect the venting system for proper size and horizontal pitch. Make sure there is no blockage or restriction, leakage, corrosion and other unsafe conditions.
3. If possible, close all building doors and windows. Close all doors between the space in which the appliances remaining connected to the common venting system are located and other building spaces.

2 Venting *(continued)*

4. Turn on clothes dryers and any other appliances not connected to the common venting system. Turn on any exhaust fans, such as range hoods and bathroom exhausts, so they will operate at maximum speed. Do not operate a summer exhaust fan.
5. Close fireplace dampers.
6. Place in operation the unit being inspected. Follow the lighting instructions. Adjust thermostat so unit will operate continuously.
7. Test for spillage at the draft hood/relief opening after 5 minutes of main burner operation. Use the flame of a match or candle, or smoke from a cigarette, cigar or pipe.
8. After making sure that each appliance remaining connected to the common venting system properly vents when tested as above, return doors, windows, exhaust fans, fireplace dampers and other gas burning appliances to their previous conditions of use.
9. Correct any improper operation of the common venting system so that the installation conforms to the latest edition of the National Fuel Gas Code, ANSI Z223.1, in Canada, the latest edition of CAN/CGA-B149 Installation Code for Gas Burning Appliances and Equipment. When resizing any portion of the common venting system, resize to approach the minimum size as determined using the appropriate tables of the latest edition of the National Fuel Gas Code, ANSI Z223.1, in Canada, the latest edition of CAN/CGA-B149 Installation Code for Gas Burning Appliances and Equipment.

Masonry chimney installations

A masonry chimney must be properly sized for the installation of a high efficiency gas-fired appliance. Venting of a high efficiency appliance into a cold or oversized masonry chimney can result in operational and safety problems. Exterior masonry chimneys, with one or more sides exposed to cold outdoor temperatures, are more likely to have venting problems. The temperature of the flue products from a high efficiency appliance may not be able to sufficiently heat the masonry structure of the chimney to generate proper draft. This will result in condensing of flue products, damage to the masonry flue/tile, insufficient draft and possible spillage of flue products into an occupied living space. Carefully inspect all chimney systems before installation.

⚠ WARNING

Do not vent this unit into a masonry chimney without a sealed stainless steel liner system. Any breaks, leaks, or damage to the masonry flue/tile will allow the flue products to leak from the chimney and into occupied living spaces. This could cause serious injury or death due to carbon monoxide poisoning and other harmful flue products.

NOTICE

Check with local code officials to determine code requirements or the advisability of using a masonry chimney with a sealed corrosion-resistant liner system.

Inspection of a masonry chimney

A masonry chimney must be carefully inspected to determine its suitability for the venting of flue products. A clay-tile-lined chimney must be structurally sound, straight and free of misaligned tile, gaps between liner sections, missing sections of liner or any signs of condensate drainage at the breaching or clean out. If there is any doubt about the condition of a masonry chimney, it must be relined with a properly-sized and approved chimney liner system. An unlined masonry chimney must not be used to vent flue products from this high-efficiency unit. An unlined chimney must be relined with an approved chimney liner system when a new appliance is being attached to it. Metallic liner systems (Type-B double-wall or flexible or rigid metallic liners) are recommended. Consult with local code officials to determine code requirements or the advisability of using or relining a masonry chimney.

Vertical vent termination clearances and location

The vent terminal should be vertical and exhaust outside the building at least 2 feet (0.61m) above the highest point of the roof within a 10 foot (3.05m) radius of the termination.

The vertical termination must be a minimum of 3 feet (0.91m) above the point of exit.

A vertical termination less than 10 feet (3.05m) from a parapet wall must be a minimum of 2 feet (0.61m) higher than the parapet wall.

Keep the vent cap clear of snow, ice, leaves, and debris to avoid blocking the flue.

2 Venting

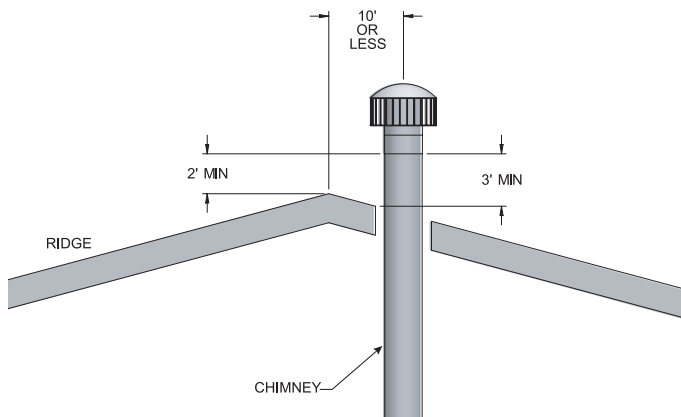

Figure 2-1_Vent Termination from Peaked Roof - 10 ft. or Less From Ridge

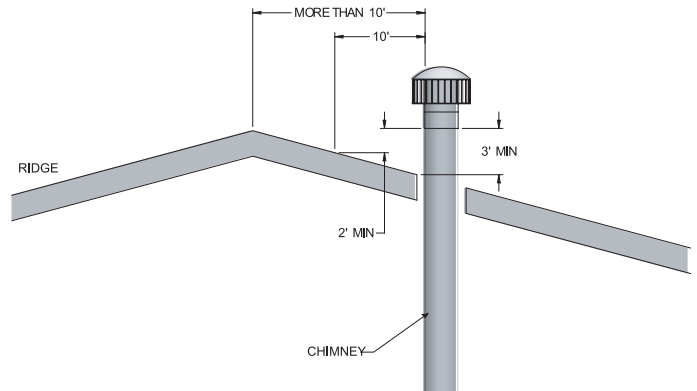

Figure 2-2_Vent Termination from Peaked Roof - 10 ft. or More From Ridge

NOTICE

Vent terminations are not shown in FIG.'s 2-1 thru 2-4. Make sure all vertical vents are installed with vent terminations recommended by the vent manufacturer.

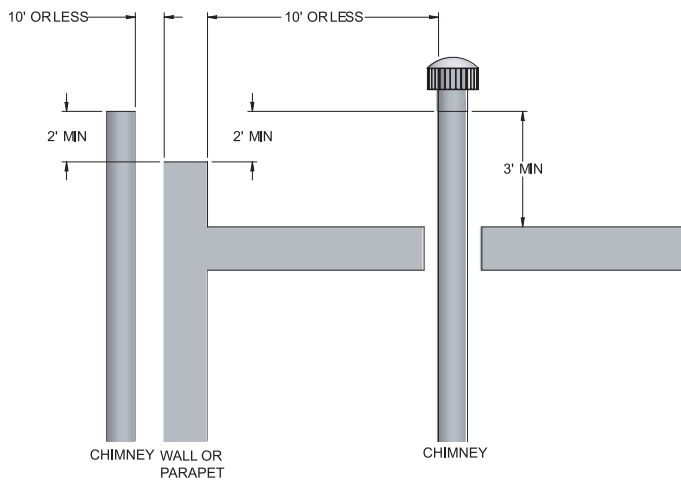

Figure 2-3_Vent Termination from Flat Roof - 10 ft. or Less From Parapet Wall

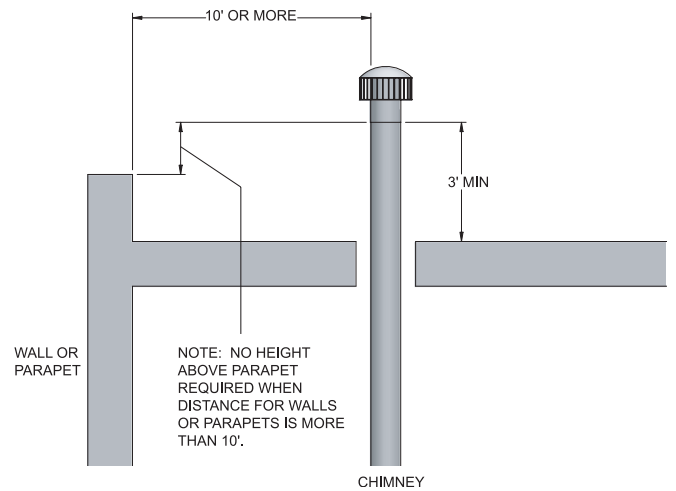

Figure 2-4_Vent Termination from Flat Roof - 10 ft. or More From Parapet Wall

2 Venting *(continued)*

Vertical DirectAire™ venting - see page 14.

B**NOTICE**

Before installing a venting system, follow requirements found in the General Venting section.

The Vertical DirectAire™ vent system is the same as the Conventional Negative Draft vent system, except it pulls combustion air from the outdoors through a separate air inlet pipe. Follow all requirements in the Conventional Negative Draft Venting section on page 16.

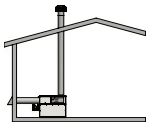

The Vertical DirectAire™ vent system requires you to install two pipes directly to the unit; one vertical pipe with a rooftop termination for the flue products and one pipe for combustion air. For this venting option, you must purchase the DV box adapter from the appliance manufacturer. The DV box attaches to the air inlet of the unit. The pipe for combustion air attaches to the DV box (see FIG. 2-11 on page 28). Reference page 28 for a list of approved air intake materials.

Combustion air inlet piping

WARNING

Locate and install the combustion air inlet cap correctly. Failure to do so can allow the discharge of flue products to be drawn into the combustion process. This can result in incomplete combustion and potentially hazardous levels of carbon monoxide in the flue products. This will cause operational problems and the spillage of flue products. Spillage of flue products can cause personal injury or death due to carbon monoxide poisoning.

The sidewall or rooftop DirectAire™ combustion air supply system has specific material and installation requirements. The air inlet pipe connects directly to the unit to supply combustion air. In most installations, the combustion air inlet pipe will be a dedicated system with one air inlet pipe per unit. You can combine multiple air inlets if the guidelines in Combined Air Inlet Points, page 20 are followed. The air inlet pipe will be connected to a combustion air inlet cap as specified in this section.

For normal installations, this system uses a single-wall pipe to supply combustion air from outdoors directly to the unit.

In cold climates, use a Type-B double-wall vent pipe or an insulated single-wall pipe for combustion air. This will help prevent moisture in the cool incoming air from condensing and leaking from the inlet pipe.

Length of air inlet pipe

The installed length of air inlet pipe from the unit to the outside air inlet cap must not exceed 50 equivalent feet (15.2m). Subtract 5 feet (1.5m) of equivalent length for each 90° elbow. Subtract 2.5 feet (0.7m) of equivalent length for each 45° elbow.

Do not exceed the limits for the combustion air inlet piping lengths.

Sidewall air inlet

The sidewall air inlet cap is supplied in the Sidewall Air Inlet Kit. Order the kit from the appliance manufacturer. This sidewall cap supplies combustion air for a single unit only. See Table 2B, page 21, for kit numbers.

Locate the unit as close as possible to the sidewall where you will install the combustion air supply system.

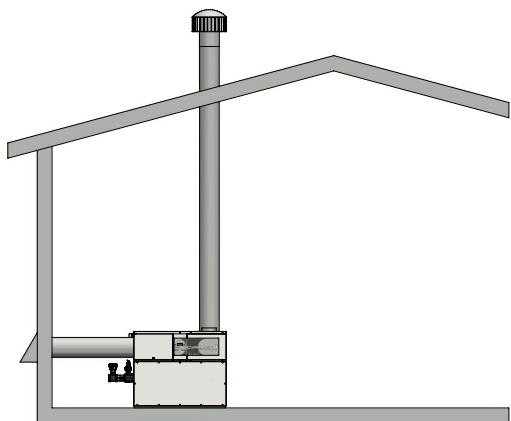

Figure 2-5_Sidewall Combustion Air Inlet

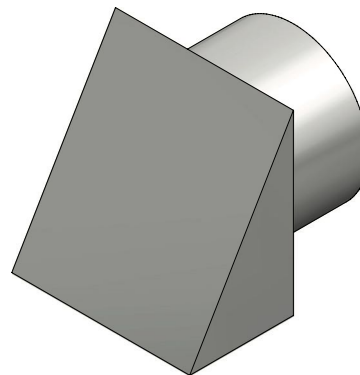

Figure 2-6_Air Inlet Cap for Sidewall Termination

2 Venting

To prevent recirculation of flue products from an adjacent vent cap into the combustion air inlet, follow all applicable clearance requirements in the latest edition of the National Fuel Gas Code and/or CAN/CGA-B149 Installation Code and instructions in the Installation and Operation Manual.

Clearances

You must install the combustion air inlet cap at least one foot (0.30m) above ground level and above normal snow levels.

The point of termination for the combustion air inlet cap must be at least 3 feet (0.91m) below the point of flue gas termination if it is located within 10 feet (3.05m) of the flue outlet. Make sure to properly install the air inlet cap assembly on the air inlet pipe.

Do not install the combustion air inlet cap closer than 10 feet (3.05m) from an inside corner of an L-shaped structure.

Vertical Rooftop Air Inlet

Use the vertical air inlet terminations available from the appliance manufacturer, recommended and/or supplied by the vent manufacturer, or use two 90° elbows as described on page 29.

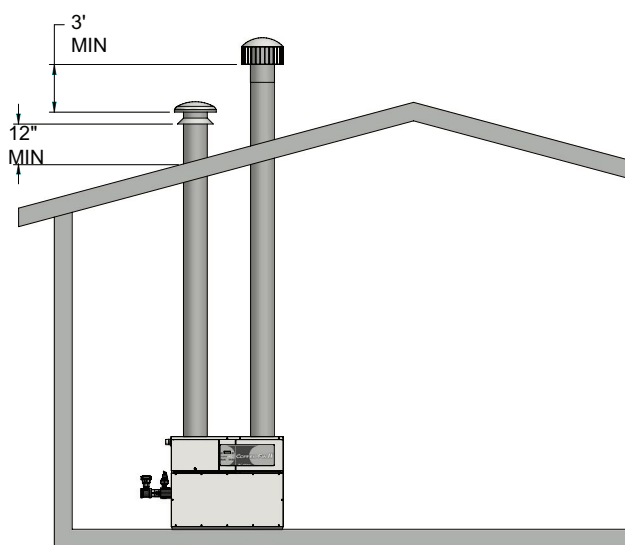

Figure 2-7_Rooftop Combustion Air Inlet

You must locate the air inlet termination elbow at least 12" (30cm) above the roof or above normal snow levels.

If the air inlet cap is within a 10-foot (3.05m) radius of the flue outlet, the point of termination for the combustion air inlet cap must be at least 3 feet (0.91m) below the point of flue gas termination (vent cap).

Do not install the combustion air inlet cap closer than 10 feet (3.05m) from an inside corner of an L-shaped structure.

Combined air inlet points

The air inlet pipes from multiple boilers can be combined to a single common connection if the common air inlet pipe has a cross sectional area equal to or larger than the total area of all air inlet pipes connected to the common air inlet pipe.

Example: Two 10" air inlet pipes (78.5 in² area each) have a total area of 157 in² and will require a 15" (176.7 in² area) common air inlet pipe.

The air inlet point for multiple boiler air inlets must be provided with an exterior opening which has a free area equal to or greater than the total area of all air inlet pipes connected to the common air inlet. This exterior opening for combustion air must connect directly to the outdoors. The total length of the combined air inlet pipe must not exceed a maximum of 50 (15.2m) equivalent feet. Subtract 5 feet (1.5m) for each 90° elbow in the air inlet pipe. You must deduct the restriction in area provided by any screens, grills or louvers installed in the common air inlet point. These are common on the sidewall air inlet openings. Screens, grills or louvers installed in the common air inlet can reduce the free area of the opening from 25% to 75% based on the materials used.

You can terminate the combustion air pipe either horizontally with a sidewall air inlet or vertically with a rooftop air inlet. The installed length of air inlet pipe from the unit to the outside air inlet cap must not exceed 50 equivalent feet (15.2m).

2 Venting *(continued)*

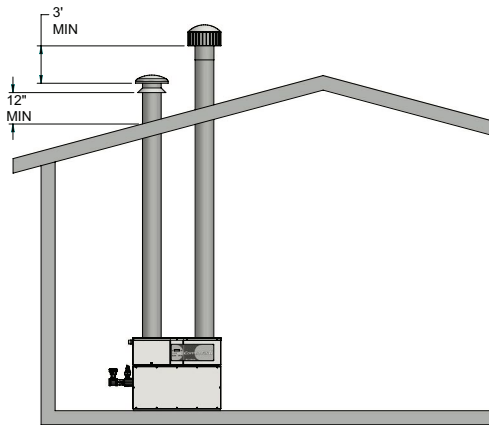

Figure 2-8 Vertical DirectAire™ Installation w/Rooftop Combustion Air Inlet

⚠ WARNING

Only use a sidewall air inlet cap supplied by the appliance manufacturer or a rooftop air inlet cap supplied by either the vent or appliance manufacturer. Using any other air inlet cap for single unit installations or using a common air inlet cap for multiple units with insufficient free area and/or protections from wind and weather may result in operational problems and the spillage of flue products. Spillage of flue products can cause personal injury or death due to carbon monoxide poisoning.

For single unit installations with sidewall air inlet you must order the sidewall air inlet kit from the appliance manufacturer. The part number for each SVK kit is listed by unit size in Table 2B.

For single unit installations with rooftop air inlet (see FIG. 2-8), you must order the rooftop air inlet kit from the appliance manufacturer. The part number for each VDK kit is listed by unit size in Table 2B. Purchase the flue pipe, rooftop flue termination, and air inlet pipe locally.

There is no vent kit for combined air supply systems for multiple units. Make sure the air inlet cap is properly sized. You must purchase this cap locally.

Venting of flue products

For venting flue products vertically to the outdoors, follow all requirements in the installation instructions for conventional venting in this manual.

Follow all clearance requirements in Vertical Vent Termination Clearances and Location on page 17.

A barometric damper is not required in the flue on Vertical DirectAire™ installations if the draft is within the negative 0.02 to 0.08 inches w.c. required for proper operation. If the draft exceeds this range, install a barometric damper.

TABLE - 2B
DIRECTAIRE KITS

MODEL	HORIZONTAL KIT*	VERTICAL KIT*
402	100169225	100172048
502	100169225	100172048
652	100169226	100172049
752	100169226	100172049
992	100169219	100172046
1262	100169220	100172047
1442	100169220	100172047
1802	100169220	100172047
2072	100169220	100172047

*The SVK kits include a DV box adapter and sidewall air inlet cap. The VDK kits include a DV box adapter and a rooftop air inlet cap.

2 Venting

Sidewall venting - see page 14.

C
NOTICE

Before installing a venting system, follow all requirements found in the General Venting section.

This option uses a powered vent assembly which pulls the flue products out of the stack. This fan generates a negative draft at the unit. Combustion air is drawn from the equipment room (see Combustion and Ventilation Air on 10).

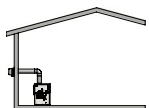

Sidewall with fan

The sidewall fan can be mounted on the inside/outside (depending upon model) with a sidewall vent hood installed on the exterior wall. The sidewall fan and accessories are included in a venting kit provided by the appliance manufacturer. See Table 2C on page 24 for kit numbers.

The venting kit includes the sidewall fan, vent hood, tapered vent adapter, barometric damper (992 - 2072 Models), proving switch and all necessary relays to interlock with the heaters control system. The tapered vent adapter reduces the vent size at the inlet to the fan. There should be no reduction in vent diameter from the unit's flue outlet to the sidewall fan. The barometric damper must be installed on the flue and adjusted to supply a negative draft within the range of 0.04 to 0.08 inches w.c. while unit is operating.

Flue outlet piping

With this venting option, you must use Type-B double-wall (or equivalent) vent materials. Vent materials must be listed by a nationally-recognized test agency for use as vent materials. Make the connections from the unit vent to the sidewall fan/cap as direct as possible with no reduction in diameter. Use the National Fuel Gas Code venting tables for double-wall vent to properly size all vent connectors and stacks. Follow the vent manufacturer's instructions when installing Type-B vents and accessories, such as firestop spacers, vent connectors, thimbles, caps, etc.

When planning the venting system, avoid possible contact with plumbing or electrical wiring inside walls.

The maximum installed length of sidewall vent pipe with an induced draft fan must not exceed 100 feet (30.5m). Subtract 5 feet (1.5m) for each 90° elbow. Subtract 2.5 feet (0.7m) for each 45° elbow.

Sidewall venting termination

The sidewall vent cap must be installed on an exterior sidewall. The sidewall fan/powered sidewall vent cap and accessories are included in a venting kit which is furnished by the appliance manufacturer in accordance with CSA International requirements. This venting kit includes the powered sidewall fan/cap, proving switch and all necessary relays to interlock with the heaters control system.

The sidewall fan/powered vent cap must be interlocked with the units control system to start the fan on a call for heat and prove fan operation before the boiler fires. Plug-in and terminal strip connections are provided on the unit for easy connection of the factory supplied vent kit and control package for the sidewall vent fan. See the installation instructions provided with the vent kit.

Sidewall vent termination clearances and location

Locate the bottom of the vent terminal at least 12 inches (30cm) above grade and above normal snow levels. Locate the bottom of the vent terminal at least 7 feet (2.13m) above grade when located adjacent to public walkways. Do not terminate directly above a public walkway.

Do not terminate the venting system in a window well, stairwell, alcove, courtyard, or other recessed area. Do not terminate the venting system below grade.

Locate vent termination at least 3 feet (0.91m) from an inside corner of an L-shaped structure.

Provide a minimum clearance of 4 feet (1.2m) horizontally from electric meters, gas meters, regulators, and relief equipment. Never locate vent cap above or below electric meters, gas meters, regulators, and relief equipment unless a 4 foot (1.2m) horizontal clearance is maintained.

2 Venting *(continued)*

Terminate the venting system at least 3 feet (0.9m) above any forced air inlet within 10 feet (3.05m).

Terminate the venting system at least 4 feet (1.2m) below, 4 feet (1.2m) beside, or 1 foot (30cm) above any door, window, or gravity air inlet into any building.

Locate vent termination at least 8 feet (2.4m) horizontally from any combustion air intake located above the sidewall termination cap.

⚠ CAUTION

Units which are shut down or will not operate may experience freezing due to convective air flow in the flue pipe, through the air inlet, or from negative pressure in the equipment room. In cold climates, operate the pump continuously to help prevent freezing of boiler water. Provide proper freeze protection. See Freeze Protection, page 47.

Sidewall venting without fan

For Models 402 - 752 which are approved for sidewall venting without an external power vent fan, you must install specific vent kits and venting materials (reference Table 2C on page 24 for kit numbers).

The following is a detailed explanation of Sidewall Venting Without an External Power Vent Fan installation requirements.

Flue outlet piping

Venting Guidelines

If using this venting option, a sealed AL29-4C venting system for flue products is required on all models of this appliance. This venting system operates with a positive pressure in the vent. The internal combustion air blower generates this positive pressure which operates the combustion process and also exhausts the flue products from the building.

This vent system has specific vent material and installation requirements. Only use listed sealed AL29-4C vent system materials. Follow all installation requirements. See Table 2A for proper pipe size for your unit. A list of sealed AL29-4C flue pipe manufacturers is located on page 15.

Seal all vent joints and seams gas-tight.

Drain tee installation

A drain tee must be installed in the vent pipe to collect and dispose of any condensate that may occur in the vent system. The drain tee must be installed as the first fitting after the horizontal ell on the top of the unit (see FIG. 2-9). Plastic drain tubing, sized per the vent manufacturer's instructions, shall be provided as a drain line from the tee. The drain tubing must have a trap provided by a 3" (7.6cm) diameter circular trap loop in the drain tubing. Prime the trap loop by pouring a small quantity of water into the drain hose before assembly to the vent. Secure the trap loop in position with nylon wire ties. Use caution not to collapse or restrict the condensate drain line with the nylon wire ties. The condensate drain must be routed to a suitable drain for disposal of condensate that may occur in the direct vent system. Refer to the condensate drain installation instructions as supplied by the manufacturer of the vent material.

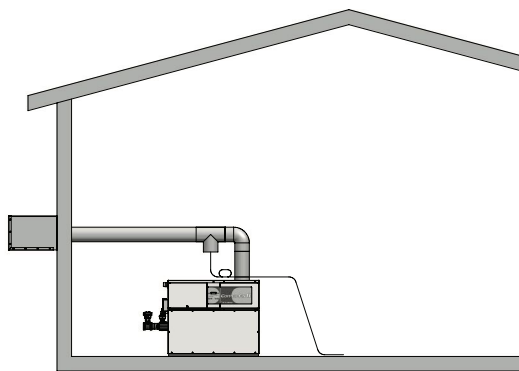

Figure 2-9_Sidewall Vent - Models 402 - 752 (Only)

2 Venting

⚠ WARNING

Do not combine the flue from this unit with the vent from any other appliance. Do not combine flues from multiple appliances into a common vent. The flue from this unit must be a dedicated stack.

Connect the flue vent directly to the flue outlet opening on the top of the unit. Make the connections from the unit vent to the outside stack as direct as possible with no reduction in diameter. Provide adequate clearance to combustibles for the vent connector and firestop. Follow the vent manufacturer's instructions when installing sealed AL29-4C vents and accessories, such as firestop spacers, vent connectors, thimbles, caps, etc.

Provide adequate clearance to combustibles for the vent connector and firestop.

When planning the venting system, avoid possible contact with plumbing or electrical wiring inside walls, ceilings, and floors.

Locate the unit as close as possible to chimney or gas vent. When a vent system is disconnected for any reason, the flue must be reassembled and resealed according to the vent manufacturer's instructions.

The installed length of flue from the unit to the outside point of termination must not exceed 50 equivalent feet (15.2m). Subtract 5 feet (1.5m) of equivalent length for each 90° elbow. Subtract 2.5 feet (0.7m) of equivalent length for each 45° elbow.

Sidewall vent termination clearances and location

Follow all sidewall venting termination information for clearances and location under Sidewall Vent Termination Clearances and Location on page 22.

**TABLE - 2C
SIDEWALL VENT KITS**

MODEL	KIT (W/POWER FAN ASSY.)	MAX. VENT LENGTH	VENT TERMINATION ONLY (MODELS 402 - 752)	MAX. VENT LENGTH
402	100169191	100 ft.	100169221	50 ft.
502	100169191	100 ft.	100169221	50 ft.
652	100169192	100 ft.	100169222	50 ft.
752	100169192	100 ft.	100169222	50 ft.
992	100169193*	100 ft.	N/A	N/A
1262	100169194*	100 ft.	N/A	N/A
1442	100169194*	100 ft.	N/A	N/A
1802	100169195*	100 ft.	N/A	N/A
2072	100169195*	100 ft.	N/A	N/A

*These kits include a barometric damper.

2 Venting *(continued)*

Horizontal DirectAire™ venting (Powered Venting) - see page 14.

D
NOTICE

Before installing a venting system, follow all requirements found in the General Venting section.

The Horizontal DirectAire™ vent system is the same as the Sidewall Venting system, except it pulls combustion air from the outdoors through a sidewall air inlet. Follow all requirements in Sidewall Venting section on page 22.

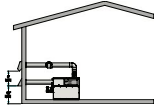

The Horizontal DirectAire™ vent system requires you to install two pipes directly to the unit; one pipe for flue products and one for combustion air. Install both pipes horizontally with a sidewall termination point. For this venting option, you must purchase the DV box accessory from the appliance manufacturer. The DV box attaches to the air inlet of the unit. The pipe for combustion air attaches to the DV box (see FIG. 2-11 on page 28). Reference page 28 for a list of approved air intake materials.

Make vent connection directly to the top of the unit. No additional draft diverter or barometric damper is required on single unit installations with a dedicated stack and a negative draft maintained between 0.04 to 0.08 inches w.c.

The Horizontal DirectAire™ combustion air supply system has specific vent material and installation requirements. The air inlet pipe connects directly to the boiler to supply combustion air. The combustion air inlet pipe is a dedicated system with one air inlet pipe per boiler. You must connect the air inlet pipe to a combustion air inlet cap as specified in this section.

Combustion air supplied from outdoors must be free of contaminants (see the Combustion and Ventilation Air section on page 10).

You must order the Horizontal DirectAire™ Vent Kit for sidewall installation from the appliance manufacturer. See Table 2D for kit numbers. Each kit includes a sidewall powered vent cap fan, proving switch, controls, combustion air inlet cap to supply air to a single unit, the transition adapter to attach the field supplied single wall air inlet pipe to the unit and installation instructions. Purchase flue pipe and air inlet pipe locally.

The sidewall air inlet cap supplied in the Horizontal DirectAire™ Vent Kit is used to supply combustion air to a single boiler. Combustion air supply pipes from multiple units can not be combined into a single air inlet pipe and inlet point.

WARNING

Only use the sidewall air inlet cap recommended by the appliance manufacturer. Using another sidewall air inlet cap may result in operational problems and the spillage of flue products. Spillage of flue products can cause personal injury or death due to carbon monoxide poisoning.

Venting of flue products

For venting flue products horizontally, follow all requirements in the installation instructions for sidewall venting.

Termination point for the flue products must follow the clearance requirements in the Sidewall Venting Termination section on page 22.

For proper operation, a barometric damper is provided for Horizontal DirectAire™ installations. The damper will help to ensure a draft between negative 0.04 to 0.08 inches w.c.

TABLE - 2D
HORIZONTAL DIRECTAIRE™ KITS

MODEL	KIT	MODEL	KIT
402	100147152	992	100147149*
502	100147152	1262	100147150*
652	100147153	1442	100147150*
752	100147153	1802	100147151*
--	--	2072	100147151*

*These kits include a barometric damper.

2 Venting

E

Direct venting - see page 14.

NOTICE

Before installing a venting system, follow all requirements found in the General Venting section.

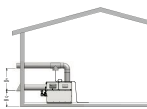

This option uses sealed AL29-4C vent materials for the flue outlet piping and separate combustion air inlet piping. This system terminates both the flue and combustion air inlet in the same pressure zone. The flue outlet and combustion air intake may terminate at either a sidewall or the rooftop.

To use the optional Direct Vent system, you must install specific vent kits and venting materials. The following is a detailed explanation of Direct Vent installation requirements, including the components used and vent kit part numbers (reference Table 2E on page 27 for kit numbers).

Flue outlet piping

Venting Guidelines

If using this venting option, a sealed AL29-4C venting system for flue products is required on all models of this appliance. This venting system operates with a positive pressure in the vent. The internal combustion air blower generates this positive pressure which operates the combustion process and also exhausts the flue products from the building.

This vent system has specific vent material and installation requirements. Only use listed sealed AL29-4C vent system materials. Follow all installation requirements. See Table 2A, page 15 for proper pipe size for your unit.

Seal all vent joints and seams gas-tight.

Drain tee installation

A drain tee must be installed in the vent pipe to collect and dispose of any condensate that may occur in the vent system. The drain tee must be installed as the first fitting after the horizontal ell on the top of the unit (see FIG. 2-9 on page 23). Plastic drain tubing, sized per the vent manufacturer's instructions, shall be provided as a drain line from the tee. The drain tubing must have a trap provided by a 3" (7.6cm) diameter circular trap loop in the drain tubing. Prime the trap loop by pouring a small quantity of water into the drain hose before assembly to the vent. Secure the trap loop in position with nylon wire ties. Use caution not to collapse or restrict the condensate drain line with the nylon wire ties. The condensate drain must be routed to a suitable drain for disposal of condensate that may occur in the direct vent system. Refer to the condensate drain installation instructions as supplied by the manufacturer of the vent material.

WARNING

Do not combine the flue from this unit with the vent from any other appliance. Do not combine flues from multiple appliances into a common vent. The flue from this unit must be a dedicated stack.

Connect the flue vent directly to the flue outlet opening on the top of the unit. Make the connections from the unit vent to the outside stack as direct as possible with no reduction in diameter. Provide adequate clearance to combustibles for the vent connector and firestop. Follow the vent manufacturer's instructions when installing sealed AL29-4C vents and accessories, such as firestop spacers, vent connectors, thimbles, caps, etc.

Provide adequate clearance to combustibles for the vent connector and firestop.

When planning the venting system, avoid possible contact with plumbing or electrical wiring inside walls, ceilings, and floors. Locate the unit as close as possible to chimney or gas vent.

When a vent system is disconnected for any reason, the flue must be reassembled and resealed according to the vent manufacturer's instructions.

The installed length of flue from the unit to the outside point of termination must not exceed 50 equivalent feet (15.2m). Subtract 5 feet (1.5m) of equivalent length for each 90° elbow. Subtract 2.5 feet (0.7m) of equivalent length for each 45° elbow.

Vertical DV venting termination

You must use the vent termination recommended by the vent manufacturer for vertical direct vent terminations. Follow all vertical venting termination information for clearances and location under the Vertical Vent Termination Clearances and Location section on pages 17 - 18.

2 Venting *(continued)*

Masonry chimney installation

Do not use a standard masonry chimney to directly vent the combustion products from this unit.

To use a masonry chimney, the chimney must use a sealed, corrosion-resistant liner system. Sealed, corrosion-resistant liner systems (single-wall, double-wall, flexible, or rigid) must be rated for use with a high efficiency, positive pressure vent system.

Corrosion-resistant chimney liner systems are typically made from a high grade stainless steel such as AL29-4C. The liner must be properly sized and fully sealed throughout the entire length. Both the top and bottom of the masonry chimney must be capped and sealed to provide a dead air space around the liner.

⚠ WARNING

Do not vent this unit into a masonry chimney without a sealed stainless steel liner system. Any breaks, leaks, or damage to the masonry flue/tile will allow the positive-pressure flue products to leak from the chimney and into occupied living spaces. This could cause serious injury or death due to carbon monoxide poisoning and other harmful flue products.

NOTICE

Check with local code officials to determine code requirements or the advisability of using a masonry chimney with a sealed corrosion-resistant liner system.

Horizontal DV venting termination

Horizontal venting uses the unit's internal combustion air blower to force the flue products out of the horizontally-terminated flue.

You must purchase a horizontal direct vent kit from the appliance manufacturer to ensure proper operation. When installing the vent cap, the wall opening must provide an air space clearance of 2 inches (5.1cm) around the flue pipe. The diameter of the opening for installation of the sidewall cap will be 4 inches (10.2cm) larger (minimum) than the nominal diameter of the installed vent pipe to the horizontal vent cap.

Install the horizontal vent cap from the outside. Mount the vent cap to the wall using four screws or wall anchors. Seal under the screw heads with caulking. Install the Category IV vent pipe from the unit to the vent cap. See detailed instructions packed with the horizontal direct vent kit.

Horizontal Vent Termination Clearances and Location

Follow all sidewall venting termination information for clearances and location under Sidewall Vent Termination Clearances and Location, page 22.

TABLE - 2E
DIRECT VENT KITS

MODEL	HORIZONTAL KIT*	VERTICAL KIT*	MODEL	HORIZONTAL KIT*	VERTICAL KIT*
402	100141702	100172048	992	100141697	100172046
502	100141702	100172048	1262	100141699	100172047
652	100141703	100172049	1442	100141699	100172047
752	100141703	100172049	1802	100141698	100172047
--	--	--	2072	100141698	100172047

*These kits include a DV box adapter, air inlet cap, and a sidewall vent termination. The VDK kits include a DV box adapter and an air inlet cap.

Combustion air inlet piping

The Direct Vent system requires the installation of a pipe to supply combustion air from the outdoors directly to the unit. Make sure the combustion air inlet is in the same pressure zone as the vent terminal.

In cold climates, use a Type-B double-wall vent pipe or an insulated single wall pipe for combustion air. This will help prevent moisture in the cool incoming air from condensing and leaking from the inlet pipe.

⚠ CAUTION

Units that are shut down or will not operate may experience freezing due to convective airflow in the air inlet pipe.

2 Venting

Length of air inlet pipe

The installed length of air inlet pipe from the unit to the outside air inlet cap must not exceed 50 equivalent feet (15.2m). Subtract 5 feet (1.5m) of equivalent length for each 90° elbow. Subtract 2.5 feet (0.7m) of equivalent length for each 45° elbow. Do not exceed the limits for the combustion air inlet piping lengths.

Connecting the air inlet pipe to the unit

Connect the air inlet piping directly to the unit by attaching it to the DV box adapter. The DV box adapter is included in the direct vent kits. The combustion air inlet area of the unit is located at the right rear corner of the unit. This unit uses a simple air filter to ensure clean air is used for the combustion process. Attach the DV box adapter over the air filter (see FIG. 2-11). Align screw holes on the DV box adapter with the screw holes surrounding the air filter hanger. Insert sheet metal screws and tighten firmly.

For venting versatility, you can move the air filter assembly and DV box adapter to the right side of the unit. Remove the metal panel on the unit's right side (see FIG. 2-12). Remove the filter/bracket assembly from the rear of the unit. Attach the filter/bracket assembly and DV box adapter to the right side opening using the pre-drilled screw holes. Make sure you attach the metal panel to the rear combustion air opening of the unit.

The DV box adapter has an air inlet pipe mounting ring. Connect combustion air inlet piping to the direct vent box mounting ring.

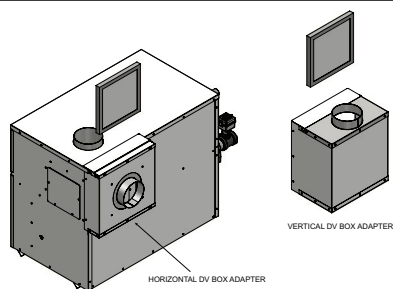

Figure 2-11 Attaching DV Box Adapter to Unit

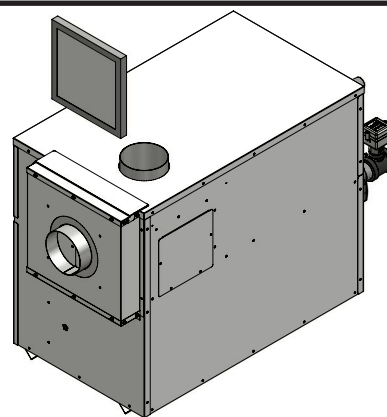

Figure 2-12 Moving Air Filter Assembly & DV Box Adapter

Air inlet piping materials

The air inlet pipe(s) must be sealed. Select air inlet pipe material from the following specified materials.

- PVC, CPVC, or ABS*
- Dryer vent or sealed flexible duct (not recommended for rooftop air inlet)
- Galvanized steel vent pipe with joints and seams sealed as specified below
- Type-B double-wall vent with joints and seams sealed as specified below.

* Plastic pipe may require an adapter (not provided) to transition between the air inlet connection on the unit and the plastic air inlet pipe.

⚠ WARNING

Use only vent or air intake materials specified in this manual. Follow vent pipe manufacturer's instructions. Failure to do so can result in property damage, personal injury, or death. Mixing of venting materials will void the warranty and certification of this unit.

Sealing Type-B double-wall vent pipe or galvanized vent pipe

Follow the steps below to properly seal Type-B double-wall vent pipe or galvanized vent pipe.

1. Seal all joints and seams of the air inlet pipe using either aluminum foil duct tape meeting UL Standard 723 or 181 A-P or a high quality UL Listed silicon sealant such as those manufactured by Dow Corning or General Electric.
2. On horizontal runs, do not install vent pipe with seams pointing down. Position vent pipe so that the seams are on the top side of the vent pipe.
3. Secure all joints with a minimum of three sheet metal screws or pop rivets. Apply aluminum foil duct tape or silicone sealant to all screws or rivets installed in the vent pipe.
4. Ensure that the air inlet pipes are properly supported.

Sealing PVC, CPVC, ABS, dryer vent, and flex duct vent pipe

1. Clean the PVC, CPVC, or ABS air inlet pipe using the pipe manufacturer's recommended solvents. Seal the pipe joints using standard commercial pipe cement.

2 Venting *(continued)*

- For PVC, CPVC, ABS, dryer vent, or flex duct air inlet piping, use a silicone sealant to ensure a proper seal at the unit inlet and the air inlet cap.
- For Dryer vent or flex duct, also use a screw-type clamp to attach the inlet vent material to the unit inlet and the air inlet cap. Properly sealing the air inlet pipe ensures that combustion air will be free of contaminants and supplied in proper volume.
- Ensure that the air inlet pipes are properly supported.

⚠ WARNING

Properly seal all joints and seams in the inlet vent piping system. Failure to do so may result in flue gas recirculation, spillage of flue products, and carbon monoxide emissions. Carbon monoxide poisoning can cause severe personal injury or death.

Vertical and sidewall combustion air inlet

NOTICE

To prevent recirculation of flue products into the combustion air inlet, follow all instructions in this section.

⚠ WARNING

Locate and install the combustion air inlet termination correctly. Failure to do so can allow the discharge of flue products to be drawn into the combustion process. This can result in incomplete combustion and potentially hazardous levels of carbon monoxide in the flue products. This will cause operational problems and the spillage of flue products. Spillage of flue products can cause personal injury or death due to carbon monoxide poisoning.

You must locate the combustion air cap and the flue gas outlet on the same rooftop surface (vertical direct vent system) or sidewall surface (horizontal direct vent system) and in the same pressure zone as the vent termination. Follow all clearance requirements listed on this page.

Purchase and assemble the combustion air inlet cap to protect the air inlet from wind and weather.

Alternatively, assemble the combustion air inlet cap for vertical rooftop air inlet from items purchased locally. The air inlet cap consists of two 90° elbows installed to the air inlet pipe (see FIG. 2-13). Install the first 90° elbow on the rooftop at the highest vertical point of the air inlet pipe. Install the second 90° elbow on the horizontal outlet of the first elbow. The outlet of the second 90° elbow will be pointing down. You may use a 90° elbow and a 90° straight elbow to make this assembly. If you use a straight piece of pipe between the two 90° elbows, it should not exceed 6" (51mm) in length.

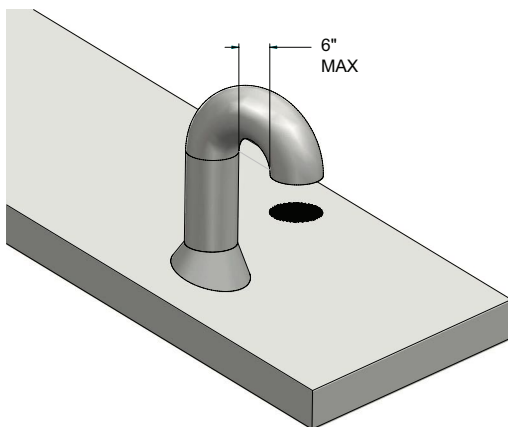

Figure 2-13_Vertical Rooftop Air Inlet

For horizontal direct vent termination of combustion air, you must use the termination cap from the appliance manufacturer. The sidewall air inlet cap is available as part of a direct vent kit. See Table 2E, page 27 for Horizontal Direct Vent Kits.

Vertical Combustion Air Inlet Clearances

You must locate the air inlet termination elbow at least 12" (30cm) above the roof or above normal snow levels.

If the air inlet cap is within a 10-foot (3.05m) radius of the flue outlet, the point of termination for the combustion air inlet cap must be at least 3 feet (0.91m) below the point of flue gas termination (vent cap).

Do not install the combustion air inlet cap closer than 10 feet (3.05m) from an inside corner of an L-shaped structure.

Horizontal combustion air inlet clearances

You must locate the horizontal air inlet termination point at least 12" (30cm) above grade and above normal snow levels.

If the air inlet cap is within a 10-foot (3.05m) radius of the flue outlet, the point of termination for the combustion air inlet cap must be at least 3 feet (0.91m) below the point of flue gas termination (vent cap). Do not install the horizontal combustion air inlet cap above the flue outlet.

Do not install the combustion air inlet cap closer than 10 feet (3.05m) from an inside corner of an L-shaped structure.

Multiple sidewall direct vent installations

You must locate the horizontal air inlet termination points at least 12" (30cm) above grade and above normal snow levels. The combustion air inlet caps for multiple appliance installations must maintain the same minimum clearance from the closest flue vent cap as specified in single appliance installations. You may install multiple flue outlet caps side-by-side and multiple combustion air inlet caps side-by-side, but the air inlet must always be at least 3 feet (0.91m) horizontally and 3 feet (0.91m) below the closest flue outlet. Do not install combustion air inlet caps above the flue outlets.

Maintain all clearances and installation requirements for multiple appliance installations.

2 Venting

F Outdoor installation - see page 14.

NOTICE Before installing a venting system, follow all requirements found in the General Venting section.

Units are self-venting and can be used outdoors when installed with the optional outdoor cap. This cap mounts directly to the top of the unit and covers the flue outlet and combustion air inlet openings. No additional vent piping is required.

WARNING Only install outdoor models outdoors and only use the vent cap supplied by the appliance manufacturer. Personal injury or product damage may result if any other cap is used or if an outdoor model is used indoors. Properly install all covers, doors and jacket panels to ensure proper operation and prevent a hazardous condition.

Combustion air supply must be free of contaminants (see Combustion and Ventilation Air, page 10). To prevent recirculation of the flue products into the combustion air inlet, follow all instructions in this section.

Outdoor vent/air inlet location

Keep venting areas free of obstructions. Keep area clean and free of combustible and flammable materials. Maintain a minimum clearance of 3" (76mm) to combustible surfaces and a minimum of 36" (915mm) clearance to the air inlet. To avoid a blocked air inlet or blocked flue condition, keep the outdoor cap air inlet, flue outlet and drain slot clear of snow, ice, leaves, debris, etc.

Do not install outdoor models directly on the ground. You must install the outdoor unit on a concrete, brick, block, or other non-combustible pad.

Do not locate unit so that high winds can deflect off of adjacent walls, buildings or shrubbery causing recirculation. Recirculation of flue products may cause operational problems, bad combustion or damage to controls. Locate unit at least 3 feet (0.91m) from any wall or vertical surface to prevent wind conditions from affecting performance.

Multiple unit outdoor installations require 48" (1.22m) clearance between each vent cap. Locate outdoor cap at least 48" (1.22m) below and 48" (1.22m) horizontally from any window, door, walkway or gravity air intake.

Locate unit at least 10 feet (3.05m) away from any forced air inlet.

Locate unit at least 3 feet (0.91m) outside any overhang.

Clearances around outdoor installations can change with time. Do not allow the growth of trees, shrubs or other plants to obstruct the proper operation of the outdoor vent system.

Do not install in locations where rain from building runoff drains will spill onto the unit.

Flue gas condensate can freeze on exterior walls or on the vent cap. Frozen condensate on the vent cap can result in a blocked flue condition. Some discoloration to exterior building or unit surfaces can be expected. Adjacent brick or masonry surfaces should be protected with a rust resistant sheet metal plate.

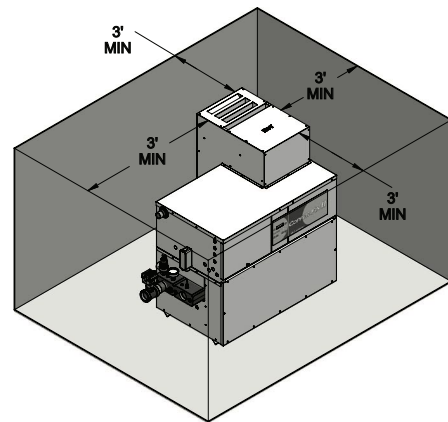

Figure 2-14_ Outdoor vent cap installed

The outdoor vent cap kit

The optional outdoor vent cap kit is available from the appliance manufacturer. The outdoor cap part numbers are listed by model number. See Table 2F for kit numbers.

Install the outdoor vent cap on the rear of the unit. Complete installation instructions are included with the outdoor vent cap kit.

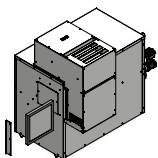

TABLE - 2F OUTDOOR VENT CAP KITS					
MODEL	KIT* WITHOUT PUMP COVER	KIT* WITH PUMP COVER	MODEL	KIT* WITHOUT PUMP COVER	KIT* WITH PUMP COVER
402	100163849	100163825	992	100163809	100163822
502	100163849	100163825	1262	100163829	100163830
652	100163850	100163826	1442	100163810	100163823
752	100163850	100163826	1802	100163781	100163780
--	--	--	2072	100163781	100163780

*These kits include an outdoor vent cap and gasket.

3 Gas connections

Connecting to gas supply

Verify that the appliance is supplied with the type of gas specified on the rating plate. This appliance is configured for operation up to 4,500 feet altitude. Consult factory for installations above 4,500 feet elevation.

Inlet gas pressure: Measured at the inlet pressure tap on the appliance gas manifold. The pressure tap is located upstream of the combination gas valve(s) (FIG. 3-3 on page 33).

See Table 3A for maximum and minimum inlet pressures. Do not exceed the maximum. Minimum inlet pressure is for the purpose of input adjustment.

MODEL	NATURAL		LP	
	Max. w.c.	Min. w.c.	Max. w.c.	Min. w.c.
402 - 2072	14.0	4.5	14.0	8.0

Manifold pressure: The gas regulator on the unit's combination gas valve is adjustable to supply proper manifold pressure for normal operation. See the Copper-fin II Service Manual for net manifold pressure settings.

If you must adjust regulator pressure, follow the instructions under Gas Manifold Pressure Adjustment in the Copper-fin II Service Manual. Do not increase regulator pressure beyond specified pressure setting.

Gas pressure test

1. The appliance must be disconnected from the gas supply piping system during any pressure testing of that system at a test pressure in excess of 1/2 PSIG (3.5 kPa).
2. The appliance must be isolated from the gas supply piping system by closing a manual shutoff valve during any pressure testing of the gas supply piping system at test pressures equal to or less than 1/2 PSIG (3.5 kPa).
3. The appliance and its gas connection must be leak tested before placing it in operation.

Gas piping

To safely operate this unit, you must properly size the gas supply piping. See Tables 3B through 3D for piping and fitting requirements. Gas pipe size may be larger than heater connection.

For ease of service, install a union.

Install a manual main gas shutoff valve, outside of the unit gas connection within six feet of the unit in accordance with the requirements of the National Fuel Gas Code, ANSI Z223.1.

You must provide a sediment trap (drip leg) in the inlet of the gas connection to the unit.

NOTICE

It is the installer's responsibility to supply the sediment trap (drip leg).

CAUTION

Do not block access to the electrical cover plate when installing the sediment trap. The sediment trap must be a minimum of 12 inches from the appliance.

The combination gas valves have an integral vent limiting device and do not require venting to atmosphere, outside the building. The unit will not operate properly if the reference hose is removed or a vent to atmosphere is installed.

Optional gas controls may require routing of bleeds and vents to the atmosphere, outside the building when required by local codes.

Gas connection

All gas connections must be made with pipe joint compound resistant to the action of liquefied petroleum (L.P.) and natural gases. All piping must comply with local codes and ordinances. Piping installations must comply with approved standards and practices.

1. Make sure gas line is a separate line direct from the meter unless the existing gas line is of sufficient capacity. Verify pipe size with your gas supplier.

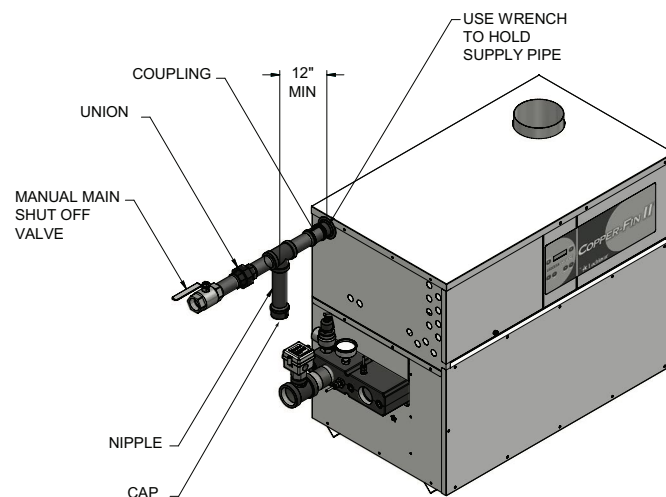

Figure 3-1_Gas Line Connection

NOTICE

If an inline high gas pressure regulator is used, it MUST BE of the lockup type and be located a minimum of 10 feet from the appliance. Failure to do so may result in insufficient gas volume supplied to the appliance.

3 Gas connections

2. Use new, properly threaded black iron pipe free from chips. If you use tubing, make sure the ends are cut square, deburred and clean. Make all tubing bends smooth and without deformation. Avoid flexible gas connections. Internal diameter of flexible lines may not provide unit with proper volume of gas.
3. Install a manual main gas shutoff valve at the unit's gas inlet, outside of the unit.
4. Run pipe or tubing to the unit's gas inlet. If you use tubing, obtain a tube to pipe coupling to connect the tubing to the unit's gas inlet.
5. Install a sediment trap in the supply line to the unit's gas inlet (see FIG. 3-1).
6. Apply a moderate amount of good quality pipe compound (do not use Teflon tape) to pipe only, leaving two end threads bare.
7. Remove seal over gas inlet to unit.
8. Connect gas pipe to inlet of unit. Use wrench to support gas manifold on the unit.
9. For L.P. gas, consult your L.P. gas supplier for expert installation.
10. Ensure that all air is completely bled from the gas line before starting the ignition sequence. Start up without properly bleeding air from the gas line may require multiple reset functions of the ignition control module to achieve proper ignition.

WARNING Do not have any open flame in proximity to the gas line when bleeding air from the gas line. Gas may be present.

Gas train and controls

NOTICE The gas train and controls assembly provided on this unit have been tested under the applicable American National Standard to meet minimum safety and performance criteria such as safe lighting, combustion and safety shutdown operation.

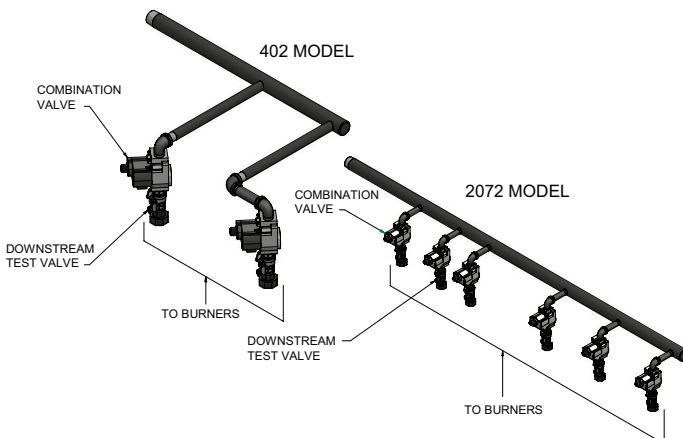

Figure 3-2_Typical Boiler Gas Train Drawing

MODEL	Distance from Meter (in feet)				
	0 - 50	51 - 100	101-200	201-300	301-500
402	1 1/4"	1 1/4"	1 1/2"	2"	2"
502	1 1/4"	1 1/2"	2"	2"	2 1/2"
652	1 1/2"	2"	2"	2 1/2"	2 1/2"
752	1 1/2"	2"	2"	2 1/2"	3"
992	2"	2"	2 1/2"	2 1/2"	3"
1262	2"	2 1/2"	2 1/2"	3"	3"
1442	2 1/2"	2 1/2"	3"	3"	3 1/2"
1802	2 1/2"	3"	3"	3 1/2"	3 1/2"
2072	2 1/2"	3"	3"	3 1/2"	4"

For each elbow or tee, add equivalent straight pipe to total length from Table 3C.

Diameter Pipe (inches)	3/4	1	1 1/4	1 1/2	2	3	4	5
Equivalent length of Straight Pipe (feet)	2	2	3	4	5	10	14	20

Combination gas valves

These units fire in multiple stages of burner input. Each stage of burner operation has a combination gas valve(s) to cycle the gas supply on and off and regulate gas to the burners. Each combination valve consists of a gas regulator and two valve seats to meet the requirements for redundant gas valves. The valve has a gas control knob that must remain in the open position at all times when the unit is in service. The gas control valve has pressure taps located on the inlet and discharge sides of the valve. Manifold pressure is adjusted using the regulator located on the valve. A manifold gas pressure tap for each burner stick is located on the discharge side of the valve.

The manifold pressure is preset at the factory and adjustment is not usually required. If you must adjust regulator pressure, follow the instructions in the Copper-fin II Service Manual.

Venting of combination gas valves

The combination gas valve/regulator used on all units is equipped with an integral vent limiting orifice per ANSI Z21.78. The vent limiter ensures that the volume of gas emitted from the valve in the event of a failed gas diaphragm does not exceed the maximum safe leakage rate allowed by agency requirements.

3 Gas connections *(continued)*

Combination gas valve/regulators equipped with integral vent limiters are not required to have vent or relief lines piped to the outdoors. The termination of the vent limited opening on the combination gas valve/regulator complies with the safety code requirements of CSD-1, CF-190(a) as shipped from the appliance manufacturer without the installation of additional vent lines.

Checking gas supply pressure

Use the following procedure to check gas supply pressure.

1. Turn the main power switch to the "OFF" position.
2. Turn gas valve knobs to the "OFF" position.
3. Shut off gas supply at the field-installed manual gas cock in the gas piping to the unit. If fuel supply is L.P. gas, shut off gas supply at the tank.
4. Remove the 1/8" hex plug, located on the "inlet" side of the gas valve. You may also use a tapping on the field-installed main manual gas cock or gas piping. Install a fitting in the inlet pressure tapping suitable to connect to a manometer or magnehelic gauge. Range of scale should be 14" w.c. or greater to check inlet pressure.
5. Turn on gas supply at the manual gas cock, turn on L.P. gas at the tank if required.
6. Turn the power switch to the "ON" position.
7. Turn the gas valve knobs to the "ON" position. Set the electronic temperature control or thermostat to call for heat.
8. Observe the gas supply pressure as all burners are firing. Ensure that inlet pressure is within the specified range. See Connecting To Gas Supply, page 31 for minimum and maximum gas supply pressures.
9. If gas pressure is out of range, contact gas utility, gas supplier, qualified installer or service agency to determine necessary steps to provide proper gas pressure to the control.
10. If gas supply pressure is within normal range, turn the power switch to the "OFF" position.
11. Turn gas valve knobs to the "OFF" position.
12. Shut off gas supply at the manual gas cock in the gas piping to the unit. If fuel supply is L.P. gas, shut off gas supply at the tank.

13. Remove the manometer and related fitting from the "inlet" side of the gas valve, replace 1/8" hex plug in gas valve and tighten.
14. Turn on gas supply at the manual valve, turn on L.P. gas at the tank if required.
15. Turn the power switch to the "ON" position.
16. Turn the gas valve knob to the "ON" position.
17. Set the electronic temperature control or thermostat to call for heat.

⚠ WARNING After completing any testing on the gas system, leak test all gas connections. Apply a soap/water solution to all gas connections while main burners are operating. Bubbles forming indicate a leak. Repair all leaks at once. Do not operate this unit with a leak in the gas train, valves or related piping.

Check burner performance by cycling the system while you observe burner response. Burners should ignite promptly. Flame pattern should be stable, see Burner Flames in the Copper-fin II Service Manual. Turn system off and allow burners to cool, then cycle burners again to ensure proper ignition and flame characteristics.

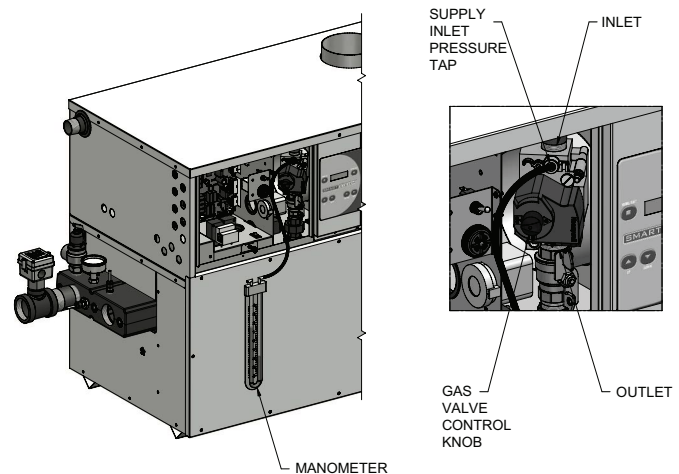

Figure 3-3 Measuring Gas Supply Pressure at Combination Gas Valve

TABLE - 3D Capacity of Schedule 40 Metallic Pipe in Cubic Feet of Natural Gas Per Hour (based on .60 specific gravity, 0.30" w.c. pressure drop)														
Pipe Size (Inches)	Length of Pipe in Straight Feet													
	10	20	30	40	50	60	70	80	90	100	125	150	175	200
1/2	131	90	72	62	55	N/A	N/A	N/A	N/A	N/A	N/A	N/A	N/A	N/A
3/4	273	188	151	129	114	104	95	89	83	79	70	63	58	N/A
1	514	353	284	243	215	195	179	167	157	148	131	119	109	102
1 1/4	1,060	726	583	499	442	400	368	343	322	304	269	244	224	209
1 1/2	1,580	1,090	873	747	662	600	552	514	482	455	403	366	336	313
2	3,050	2,090	1,680	1,440	1,280	1,160	1,060	989	928	877	777	704	648	602
2 1/2	4,860	3,340	2,680	2,290	2,030	1,840	1,690	1,580	1,480	1,400	1,240	1,120	1,030	960
3	8,580	5,900	4,740	4,050	3,590	3,260	3,000	2,790	2,610	2,470	2,190	1,980	1,820	1,700
4	17,500	12,000	9,660	8,270	7,330	6,640	6,110	5,680	5,330	5,040	4,460	4,050	3,720	3,460

4 Water connections

Inlet and outlet connections

For ease of service, install unions on the water inlet and water outlet of the unit. The connection to the unit marked “Inlet” on the header should be used for return from the system. The connection on the header marked “Outlet” is to be connected to the supply side of the system.

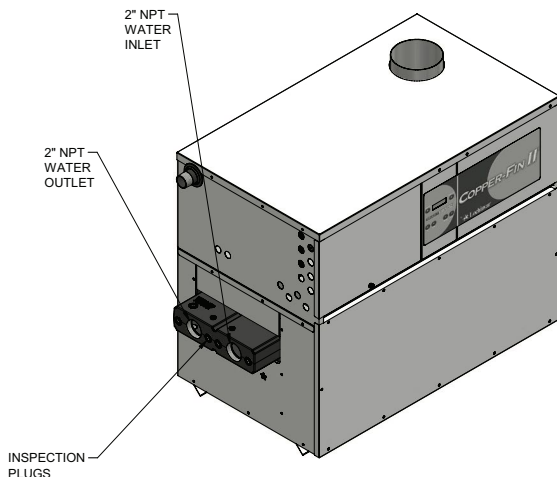

Figure 4-1_Water Connections - Models 402 - 752

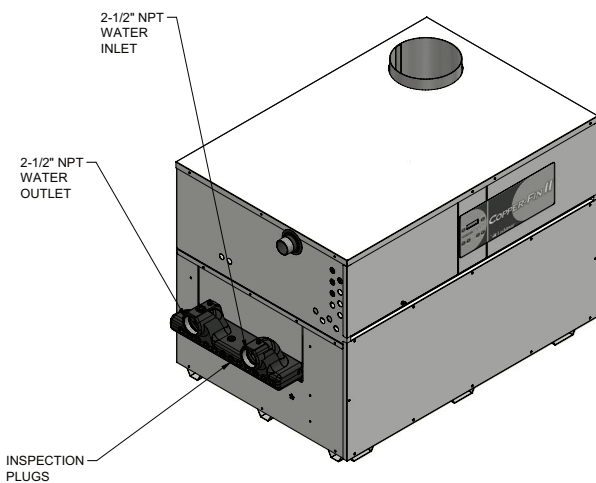

Figure 4-2_Water Connections - Models 992 - 2072

Heat exchanger

This appliance uses a finned copper tube heat exchanger to maximize the heat transfer process. The heat exchanger is mounted in the inner jacket of the appliance. A series of “V” shaped baffles are installed between the individual tubes to control the movement of the flue products over the finned copper surface and increase heat transfer. Water enters the heat exchanger and makes two passes over the area exposed to direct heat from the burner. A circulating pump **MUST** be installed to ensure proper water flow over the heat transfer surfaces during burner operation. Water temperatures in the heat exchanger are determined by water flow.

Initial set-up of maximum water flow

On initial start-up of the Copper-fin II, the maximum water flow to the heat exchanger must be checked and manually limited with a valve or bypass before normal operation begins.

CAUTION

An appliance allowed to operate at return temperatures below the specified minimum setting may experience problems with the operating controls, safety switches, obstruction of the flue gas passages on the heat exchanger, incomplete combustion and possible flue gas spillage. Sustained operation at lower than specified water temperatures (140°F) may cause hazardous conditions that may result in personal injury or non-warrantable damage to the appliance.

Water flow switch

A water flow switch is factory installed in the outlet on all heating boilers and hot water supply boilers. The flow switch must prove water flow before a trial for ignition can begin. The flow switch requires a minimum flow of 15 - 18 GPM on Models 402 - 752 and 26 GPM on Models 992 - 2072 to make the flow switch and start burner operation. A water flow switch meets most code requirements for a low water cutoff device on boilers requiring forced circulation for operation. A fault message, **Flow Sw/LWCO** will be indicated in the Operator Interface on a low water flow condition as sensed by the flow switch.

Low water cutoff (if equipped)

If this boiler is installed above radiation level, a low water cutoff device must be installed at the time of boiler installation. An electronic low water cutoff is available as a factory supplied option on all models. The low water cutoff should be inspected every 6 months. A fault message, **Flow Sw/LWCO** will be indicated in the Operator Interface on a low water condition as sensed by the low water cutoff.

4 Water connections *(continued)*

Relief valve

This unit is supplied with a relief valve(s) sized in accordance with ASME Boiler and Pressure Vessel Code, Section IV (“Heating Boilers”). The relief valve(s) is installed in the vertical position and mounted in the hot water outlet. No valve is to be placed between the relief valve and the unit. To prevent water damage, the discharge from the relief valve shall be piped to a suitable floor drain for disposal when relief occurs. No reducing couplings or other restrictions shall be installed in the discharge line. The discharge line shall allow complete drainage of the valve and line. Relief valves should be manually operated at least once a year.

CAUTION Avoid contact with hot discharge water.

Heating boiler installations

Piping of the boiler system

The drawings in this section show typical boiler piping installations, see FIG.’s 4-3 through 4-6. Before beginning the installation, consult local codes for specific plumbing requirements. The installation should provide unions and valves at the inlet and outlet of the boiler so it can be isolated for service. An air separation device must be supplied in the installation piping to eliminate trapped air in the system. Locate a system air vent at the highest point in the system. The system must also have a properly sized expansion tank installed. Typically, an air charged diaphragm-type expansion tank is used. The expansion tank must be installed close to the boiler and on the suction side of the system pump to ensure proper operation. A water meter to monitor makeup water is recommended. Makeup water volume should not exceed 5% of total system per year. Install a Y-strainer or equivalent multi-purpose strainer just before the boiler pump at the inlet of the heat exchanger. This item is used to remove system debris from older hydronic systems and to protect newer systems.

CAUTION The boiler system should not be operated at less than 12 PSIG (83 kPa) (Non-metallic system piping must have an oxygen barrier to be considered a closed loop).

IMPORTANT All boiler piping must contain an oxygen barrier. This will help prevent any excess oxygen from entering the system.

Hot water piping must be supported by suitable hangers or floor stands, **NOT** by the boiler. Copper pipe systems will be subject to considerable expansion and contraction. Rigid pipe hangers could allow the pipe to slide in the hanger resulting in noise transmitted into the system. Padding is recommended on rigid hangers installed with a copper system. The boiler pressure relief valve must be piped to a suitable floor drain. See the *Relief Valve* section on this page.

CAUTION A leak in a boiler “system” will cause the “system” to intake fresh water constantly, which will cause the tubes to accumulate a lime/scale build up. This will cause a non-warrantable failure.

Water connections (heating boilers only)

Models 402 - 752 have 2" NPT inlet and outlet connections and Models 992 - 2072 have 2 1/2" NPT inlet and outlet connections.

CAUTION

Field installed reducing bushings must not be used.

Any reduction in pipe size may decrease flow resulting in high water temperatures, boiler noise, flashing to steam, and non-warrantable heat exchanger damage.

The boiler may be installed with a primary/secondary piping system provided to the boiler. It is important to guarantee that adequate flow is provided to properly dissipate heat from the boiler and also ensure that flow through the boiler does not exceed the maximum recommended flow rate of 55 GPM for Models 402 - 752 and 90 GPM for Models 992 - 2072 for a boiler equipped with a copper heat exchanger.

Boiler circulator requirements

This is a low mass, high efficiency hot water boiler which must have adequate flow for quiet, efficient operation. Pump selection is critical to achieve proper operation. A pump should be selected to achieve proper system design water temperature rise. Pipe diameter and length are critical to ensure proper flow through the boiler. A System Temperature Rise Chart (Table 4C on page 38) is provided to assist in proper pump selection. This table provides GPM and boiler head-loss at various temperature rises for each model based on Btu/hr input. Temperature rise is the difference in boiler inlet temperature and boiler outlet temperature while the boiler is firing at full rate.

Example: The boiler inlet temperature is 160°F (71.1°C) and the boiler outlet temperature is 180°F (82.2°C). This means that there is a 20°F (11.1°C) temperature rise across the boiler. The boiler temperature rise is visible in the Operator Interface on the boiler’s front control panel.

Circulator pump specifications

1. Maximum operating pressure for the pump must exceed system operating pressure.
2. Maximum water temperature should not exceed the nameplate rating.
3. Cast iron circulators may be used for closed loop systems.
4. A properly sized expansion tank must be installed near the boiler and on the suction side of the pump.

Circulator pump operation (heating boilers only)

The boiler pump must run when the boiler is firing. Separate supply circuits can be provided or the two circuits (pump and controls) can be combined for connection to one circuit, properly sized for both.

4 Water connections

Pump delay operation

A pump delay operation feature is provided. The boiler's circulating pump will cycle on at each call for heat, before the burner fires. The pump will continue to operate while the burner is firing. The pump will run for a 30 second period after the temperature set point is satisfied. This timing is selectable from the Operator Interface. This timing will remove any of the residual heat from the combustion chamber before turning the pump off. See the wiring diagram in Section 9 of this manual.

Pump Maintenance: Inspect the pump every six (6) months and oil as necessary. Use SAE 30 non-detergent oil or lubricant specified by the pump manufacturer.

The boiler is recommended for installation in a primary/secondary piping system. This type of system uses a separate boiler circulating pump to supply flow to and from the boiler only. The secondary pump is sized based on the head loss of the boiler and related pipe and fittings in the secondary loop only.

A properly sized primary system pump provides adequate flow to carry the heated boiler water to radiation, air over coils, etc. The fittings that connect the boiler to the primary system should be installed a maximum of 12 inches (0.30m) (or 4 pipe diameters) apart to ensure connection at a point of zero pressure drop in the primary system. There should be a minimum of 10 pipe diameters of straight pipe before and after the boiler secondary loop connections to prevent turbulent flow at the secondary loop connections. The secondary loop piping to and from the boiler must have a fully ported ball valve installed in both the supply and return side piping. The ball valves must be fully ported having the same inside diameter as the installed piping. The ball valve in the piping supplying water to the boiler will only be used as a service valve. The ball valve installed in the discharge from the boiler back to the primary system will be used to adjust boiler flow and temperature rise to ensure proper performance.

The boiler primary piping system must have a circulator installed in the main system loop to carry the heated boiler water to the point of use in the main system.

Multiple boilers may also be installed with a primary/secondary manifold system. Multiple boilers should be connected to the common manifold in reverse return to assist in balancing flow to multiple boilers.

The installer must ensure that the boiler has adequate flow without excessive temperature rise. Low system flow can result in overheating of the boiler water which can cause short burner cycles, system noise, relief valve discharge and in extreme cases, a knocking flash to steam. These conditions indicate the need to increase boiler flow to and from the boiler. This is generally accomplished by either increasing the size of the boiler pump or by increasing the diameter of the piping that connects the boiler to the primary system. A larger diameter pipe reduces head loss and increases flow.

CAUTION

At no time should the system pressure be less than 12 PSIG.

Minimum boiler water temperatures

Inlet water temperatures below the specified minimum of 140°F (60°C) can excessively cool the products of combustion resulting in condensation on the heat exchanger. Condensation on the heat exchanger can cause operational problems, bad combustion, sooting, flue gas spillage and reduced service life of the related components. See the Low Temperature Bypass Requirements section for boiler system applications below the minimum specified temperature.

Low Temperature Return Water Systems

Any non-condensing boiler will develop operational problems when exposed to inlet water temperatures below 140°F. Lochinvar offers a low temperature protection valve (LTV) that is factory preset to maintain 140°F inlet water to the boiler regardless of the system return water temperature. See Table 4A for available valve kits.

MODEL	LTV VALVE KIT
402 - 752	100172001
992 - 2072	100172000

Low temperature bypass requirements

To prevent condensation problems, a boiler **MUST NOT** be operated (other than for brief periods during initial system startup) with an inlet water temperature of less than 140°F (60°C). If normal system return temperatures are less than the required 140°F (60°C) boiler inlet requirement, a method of low return water temperature protection **MUST BE** provided to protect the boiler.

For Example: *Night Setback* of the system loop water temperature, *Night Shutdown* and *Weekend Shutdown* of the entire boiler / heating system, and *Indoor / Outdoor Air Reset* of the system loop water temperature. If any of these control functions are being utilized, some type of low return water protection **MUST BE** provided.

If the boiler heating system will be used on a Water Source Heat Pump System, Radiant Floor Heating System, Snow Melting Heating System, etc., some type of low return water protection must be provided.

Condensation can cause operational problems, bad combustion, sooting, flue gas spillage and reduced service life of the vent system and related components.

To prevent system return water temperature below 140°F (60°C) from entering the boiler inlet, an electrically actuated 3-way mixing valve (100171920) is available, consult manufacturer for kit availability (see FIG. 4-5 on page 41). By using this valve, the SMART SYSTEM control will bypass outlet water back into the inlet of the boiler to maintain the inlet temperature above 140°F (60°C).

A fast acting, self contained mixing valve, set to 140°F (60°C), may also be used. The installation of this valve must be done as shown in FIG. 4-5. This arrangement will maintain the required flow through the boiler.

4 Water connections *(continued)*

When a mixing valve is used, an optional system return sensor should be installed into the system return piping. This will allow the display of the actual system return temperature, and will also allow control of the system return temperature when the SMART SYSTEM control is programmed for inlet temperature control. As always, installation of the system supply sensor is strongly recommended as well. This will reduce the potential for short cycling of the boiler, and provide more responsive temperature regulation, even when the SMART SYSTEM control is programmed for inlet temperature control.

⚠ CAUTION

A boiler allowed to operate at set point temperatures below the specified minimum settings may experience operational problems with the operating controls and safety switches, obstruction of the flue gas passages on the heat exchanger, incomplete combustion and possible flue gas spillage. Operation at lower than specified water temperatures may cause hazardous conditions that result in non-warrantable damage to the appliance.

Three way valves in system

The installation of a three way valve on this boiler is not generally recommended because most piping methods allow the three way valve to vary flow to the boiler. This boiler is a low mass, high efficiency appliance which **requires a constant water flow rate for proper operation**. Low flow rates can result in overheating of the boiler water which can cause short burner cycles, system noise, relief valve discharge and in extreme cases, a knocking flash to steam. These conditions can cause operational problems and non-warrantable failures of the boiler.

Radiant floor and snow melt heating systems

This type of heating boiler application operates in a low temperature range which requires a boiler bypass as described under the Low Temperature Bypass Requirements section. A non-metallic rubber or plastic tubing installed in a radiant (in floor) system must have an oxygen barrier to prevent oxygen from entering the system through the walls of the installed tubing. Excessive oxygen absorption into the system will result in an accelerated rate of corrosion causing a sludge buildup. This excessive corrosion will also damage the boiler and system components. Sludge formed as the result of excessive oxygen in the system can restrict water flow resulting in a premature boiler failure. Any boiler damage due to excessive oxygenation is non-warrantable.

TABLE - 4B
MAXIMUM FLOW FOR HEATING BOILER

The maximum flow rate through the boiler with a copper heat exchanger must not exceed the following:

Model	Maximum Flow	Maximum Flow for CuNi Heat Exchanger
402, 502, 652, and 752	55 GPM	75 GPM
992, 1262, 1442, 1802, and 2072	90 GPM	115 GPM

Low system water volume

System run time is very important to the overall operating efficiency of the boiler. Short cycling of the boiler creates problems with condensation in the vent stack, condensation on the heat exchanger, system temperature spikes, and mechanical component failures. To prevent short cycling of the boiler, it is important to limit the boiler cycles to six or fewer per hour.

A buffer tank is an effective way to enhance a small system load and increase heating system efficiency (see FIG. 4-6 on page 42 of this manual). Buffer tanks add water volume to the system and act as a flywheel to absorb the additional Btu's provided by the boiler when only a single zone of a large system is calling for heat.

To calculate the proper buffer tank size for a multiple zone system:

$$\frac{(\text{Run Cycle}) (\text{Output} - \text{Minimum System Load})}{(\text{Temp. Rise}) (8.33) (60 \text{ Min.})}$$

CFN2072

Min. Load = 100,000 Btu/Hr

Min. Boiler Output = 850,000 Btu/Hr

Cycle Time = 10 Min

Temp. Rise = 38

$(10)(850,000 - 100,000) / (38)(8.33)(60) = 395 \text{ Gallons}$

Y-strainer:

Install a field supplied Y-strainer or equivalent multi-purpose strainer just before the boiler pump at the inlet of the heat exchanger. This item is used to remove system debris from older hydronic systems and to protect newer systems.

4 Water connections

TABLE - 4C
SYSTEM TEMPERATURE RISE CHART
 Temperature Rise and Head Loss Based on Boiler Output in Btu/hr

Btu/hr		30°F ΔT		35°F ΔT		40°F ΔT		45°F ΔT		50°F ΔT		55°F ΔT		60°F ΔT	
Input	Output	GPM	Ft/hd	GPM	Ft/hd	GPM	Ft/hd	GPM	Ft/hd	GPM	Ft/hd	GPM	Ft/hd	GPM	Ft/hd
399,000	339,000	23	1.1	19	0.7	--	--	--	--	--	--	--	--	--	--
500,000	425,000	28	1.6	24	1.2	21	0.7	19	0.7	--	--	--	--	--	--
650,000	553,000	37	3.0	31	2.2	28	1.6	24	1.2	22	0.9	20	0.7	18	0.6
750,000	638,000	42	4.1	36	2.8	32	2.3	28	1.6	25	1.3	23	1.1	21	0.7
990,000	842,000	55	2.6	48	2.3	42	1.5	37	1.4	33	1.0	30	0.9	28	0.9
1,260,000	1,071,000	71	4.4	61	3.6	53	2.7	48	2.3	42	1.7	39	1.5	35	1.2
1,440,000	1,224,000	81	6.3	70	5.0	61	3.8	54	2.7	48	2.3	44	2.0	40	1.8
1,800,000	1,530,000	102*	11.8	87	9.0	76	6.6	68	5.6	61	4.4	55	2.6	50	3.0
2,070,000	1,760,000	--	--	100*	10.1	87	9.0	78	7.6	70	6.2	64	5.4	58	4.6

*Cupro-Nickel Heat Exchanger Required at Flows Above 55 GPM on Models 402 - 752 and above 90 GPM on Models 992 - 2072.

TABLE - 4D
BOILER TEMPERATURE RISE AT MAXIMUM FLOW
 Temperature Rise at Full Rate Fire, 55 and 90 GPM
 Maximum Flow

Model	Temperature Rise °F
402	12 @ 55 GPM
502	15 @ 55 GPM
652	20 @ 55 GPM
752	23 @ 55 GPM
992	19 @ 90 GPM
1262	24 @ 90 GPM
1442	27 @ 90 GPM
1802	34 @ 90 GPM
2072	39 @ 90 GPM

Boiler bypass requirements

The installer must ensure that the boiler is supplied with adequate flow without excessive temperature rise. It is recommended that this boiler be installed with a bypass in the piping if the maximum recommended flow rate is exceeded. The bypass will help to ensure that the boiler can be supplied with adequate water flow. Flow rates exceeding the maximum recommended flow will result in erosion of the boiler tubes. A typical bypass with a valve as shown in FIG. 4-5 will allow control of boiler flow.

Temperature / pressure gauge

This boiler is equipped with a dial type temperature / pressure gauge. This gauge is factory installed in the outlet side of the boiler piping. The gauge has one scale to read system pressure and a separate scale to read water temperature in degrees Fahrenheit. The temperature / pressure gauge is provided to meet code requirements. Water temperatures can be more accurately monitored from the data provided in the digital display in the Operator Interface.

Typical heating boiler installations

General plumbing rules:

1. Check all local codes.
2. For serviceability of boiler, always install unions.
3. Always pipe pressure relief valve to an open drain.
4. Locate system air vents at highest point of system.
5. Expansion tank must be installed near the boiler and on the suction side of the system pump.
6. Support all water piping.

Installation with a chilled water system

Pipe refrigeration systems in parallel. Install duct coil downstream at cooling coil. Where the hot water heating boiler is connected to a heating coil located in the air handling units which may be exposed to refrigeration air circulation, the boiler piping system must be equipped with flow control valves or other automatic means to prevent gravity circulation of the boiler water during the cooling cycle.

The coil must be vented at the high point and hot water from the boiler must enter the coil at this point. Due to the fast heating capacity of the boiler, it is not necessary to provide a ductstat to delay circulator operation. Also, omit thermostat flow checks as the boiler is cold when heating thermostat is satisfied. This provides greater economy over maintaining standby heat.

DHW installation

Boilers may be utilized with a Hot Water Generator tank for domestic hot water. When used for DHW, either a tank thermostat or sensor must be installed in a bulbwell within the tank and connected back to the unit in order for the controller to regulate water temperature and a pump for DHW. Pumps used for DHW purposes should be sized to provide adequate flow to the boiler when in DHW Mode. Reference FIG. 4-3 shown with a Hot Water Generator for DHW on page 39 for a typical DHW piping scheme.

4 Water connections *(continued)*

Figure 4-3_Primary/Secondary Piping of a Single Boiler w/DHW

COMMON MANIFOLD SIZE (Min.) Models: 402, 502, 652, & 752		
Number of Units	GPM	Diameter (in.)
1	55	2

COMMON MANIFOLD SIZE (Min.) Models: 992, 1262, 1442, 1802 & 2072		
Number of Units	GPM	Diameter (in.)
1	90	2 1/2

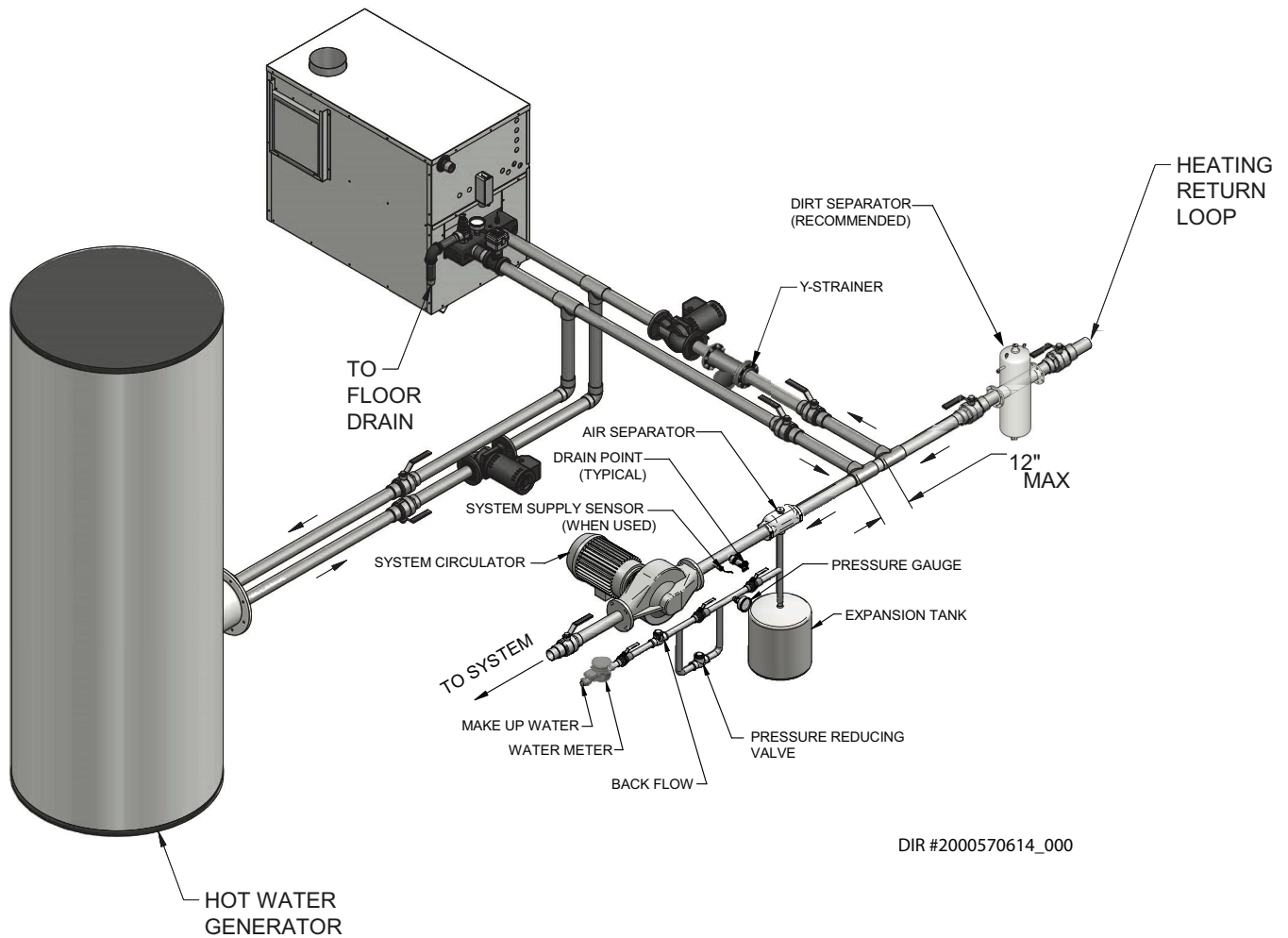

DIR #2000570614_000

NOTICE

Please note that these illustrations are meant to show system piping concept only, the installer is responsible for all equipment and detailing required by local codes.

4 Water connections

Figure 4-4_Primary/Secondary Piping of Multiple Boilers

COMMON MANIFOLD SIZE (Min.) Models: 402, 502, 652, & 752		
Number of Units	GPM	Diameter (in.)
2	110	3
3	165	3 1/2
4	220	4
5	275	5
6	330	5
7	385	6
8	440	6

COMMON MANIFOLD SIZE (Min.) Models: 992, 1262, 1442, 1802 & 2072		
Number of Units	GPM	Diameter (in.)
2	180	4
3	270	5
4	360	6
5	450	6
6	540	6
7	630	8
8	720	8

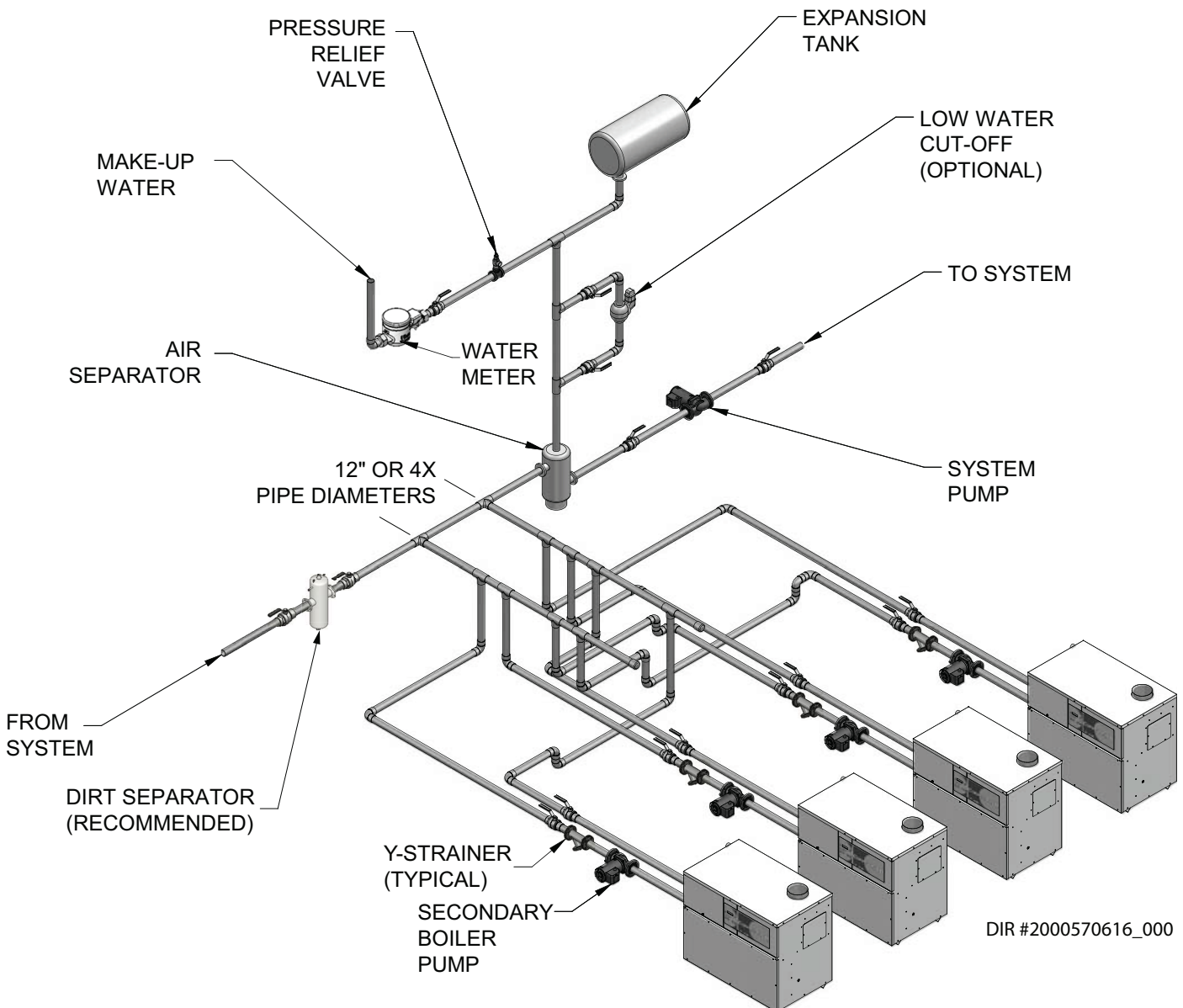

DIR #2000570616_000

NOTICE Please note that these illustrations are meant to show system piping concept only, the installer is responsible for all equipment and detailing required by local codes.

4 Water connections *(continued)*

Figure 4-5_Boiler with Low Temperature Bypass Piping - Using a Low Temperature Valve Required for Systems Operating at less than 140°F (60°C) Return Water Temperatures from the Heating Return Loop

COMMON MANIFOLD SIZE (Min.) Models: 402, 502, 652, & 752		
Number of Units	GPM	Diameter (in.)
1	55	2

COMMON MANIFOLD SIZE (Min.) Models: 992, 1262, 1442, 1802 & 2072		
Number of Units	GPM	Diameter (in.)
1	90	2 1/2

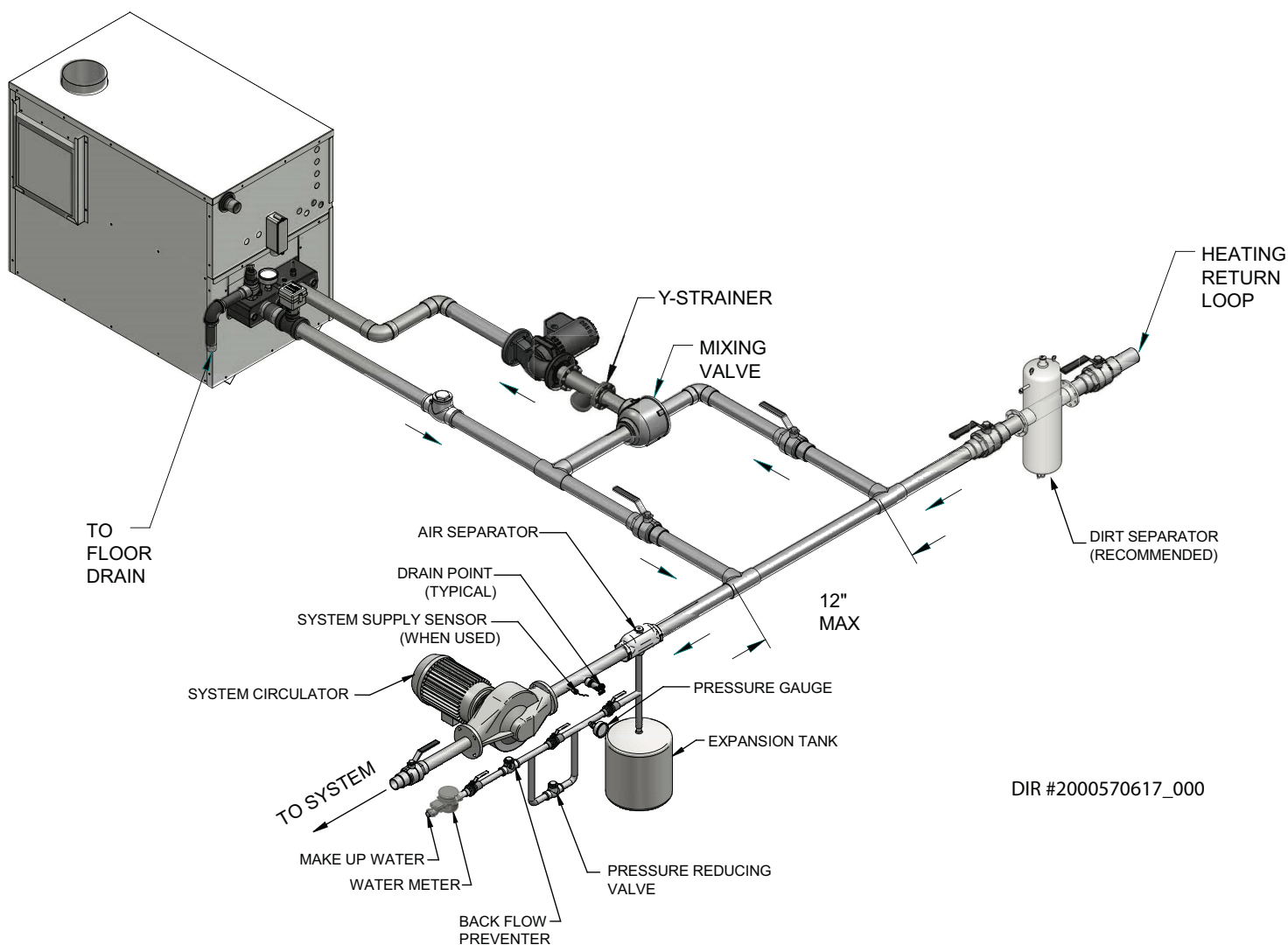

DIR #2000570617_000

NOTICE Please note that these illustrations are meant to show system piping concept only, the installer is responsible for all equipment and detailing required by local codes.

4 Water connections

Figure 4-6 Primary/Secondary Piping with Buffer Tank

COMMON MANIFOLD SIZE (Min.) Models: 402, 502, 652, & 752		
Number of Units	GPM	Diameter (in.)
2	110	3
3	165	3 1/2
4	220	4
5	275	5
6	330	5
7	385	6
8	440	6

COMMON MANIFOLD SIZE (Min.) Models: 992, 1262, 1442, 1802 & 2072		
Number of Units	GPM	Diameter (in.)
2	180	4
3	270	5
4	360	6
5	450	6
6	540	6
7	630	8
8	720	8

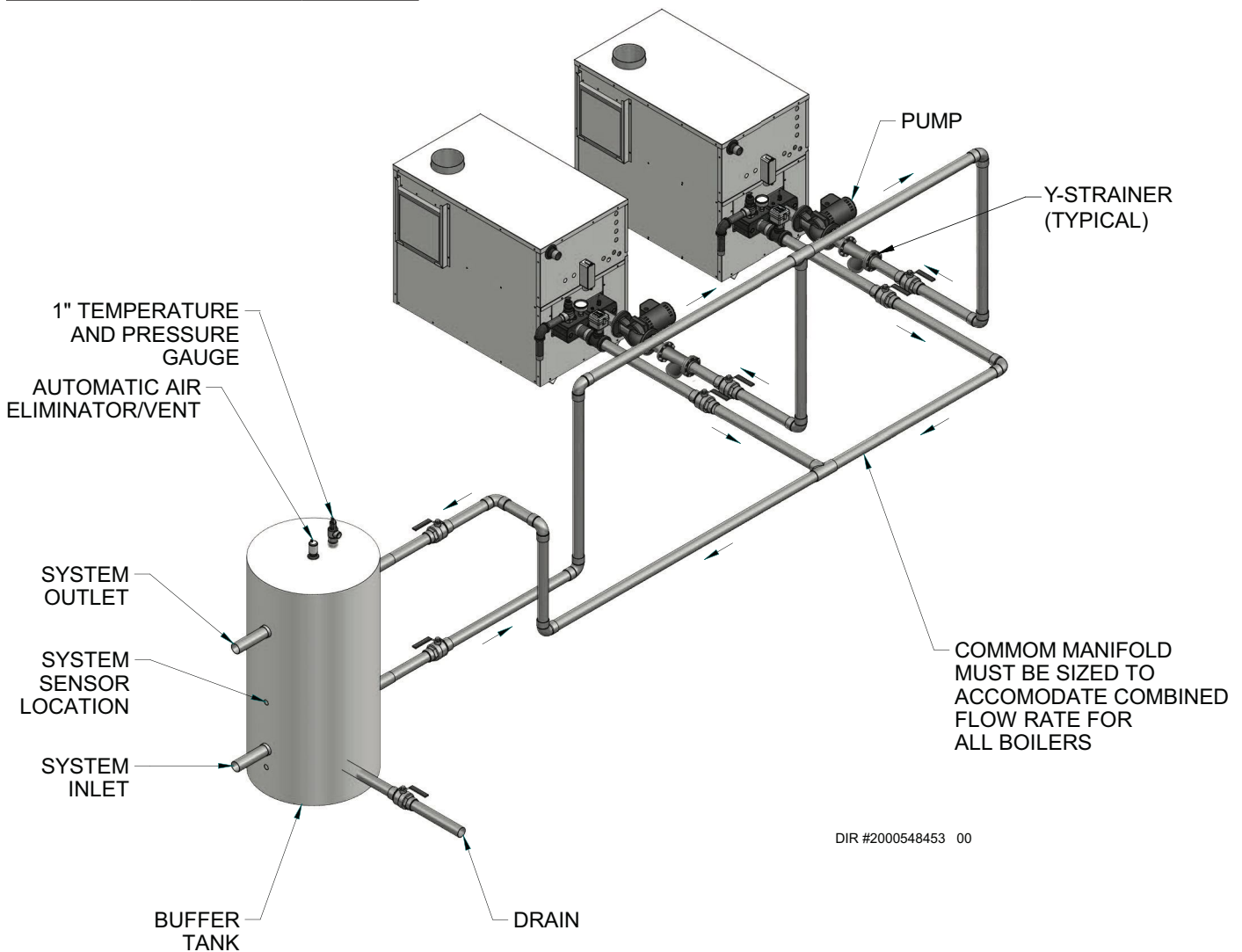

DIR #2000548453 00

NOTICE The Inlet/Outlet System tappings are shown in the optional location on the side of the tank for pictorial purposes. The standard location for the system tappings is 180° from the recirculation tappings.

NOTICE Please note that these illustrations are meant to show system piping concept only, the installer is responsible for all equipment and detailing required by local codes.

5 Electrical connections

Boiler operating control module

The operating control for the appliance is the SMART SYSTEM control module. It is located on the inside of the control panel, behind the front access door. Access to adjust the temperature set point and other user adjustable points is made through the Operator Interface located on the front access door. The outlet sensor is installed in the outlet side of the heat exchanger top header. The inlet sensor is located on the inlet side of the heat exchanger top header.

The operating sensor, inlet or outlet, is selectable from the screen in the Operator Interface.

The exact temperature set point is based on the system's requirements. Set the control set point(s) to the desired operating water temperature.

The maximum temperature set point that can be programmed into the control module from the Operator Interface on a heating boiler is 220°F (104.4°C). The manual reset high limit control for a heating boiler is adjustable up to a fixed maximum setting of 230°F (110°C).

The maximum temperature set point for a hot water supply boiler is 190°F (88°C). The auto reset high limit is fixed at 200°F (93°C), and the adjustable manual reset high limit has a maximum setting of 230°F (110°C).

A 120 VAC, 15 Amp, 1 ph, 60 Hz circuit is required for operation of the appliance controls.

The appliance, when installed, must be electrically grounded in accordance with the requirements of the authority having jurisdiction or in the absence of such requirements, with the latest edition of the National Electrical Code ANSI/NFPA No. 70. When the unit is installed in Canada, it must conform to the CAE C22.1, Canadian Electrical Code, Part I and/or local Electrical Codes. Multiple units connected in a Cascade must be grounded to the same ground connection.

1. All wiring between the appliance and field installed devices shall be made with type T wire [63°F (35°C) rise].
2. All line voltage wire exterior to the appliance must be enclosed in approved conduit or approved metal clad cable.
3. The circulating pump must run continuously when the appliance is being fired.
4. To avoid serious damage, DO NOT energize the appliance until the system is full of water. Ensure that all air is removed from the heat exchanger and piping before beginning initial operation. Serious damage may result if the appliance is operated without proper flow.
5. Provide the appliance with proper overload protection.

TABLE - 5A
AMP DRAW DATA

Model	Controls	Blower	Pump FLA*	Approximate Total Amps @ 120 VAC
402	3.6	2.7	5.8	12.1
502	3.6	2.7	5.8	12.1
652	5.4	3.4	5.8	14.6
752	5.4	3.4	5.8	14.6
992	7.3	3.2	7.4	17.9
1262	7.3	3.2	7.4	17.9
1442	7.3	6.7	7.4	21.4
1802	7.3	6.7	7.4	21.4
2072	7.3	6.7	7.4	21.4
*Standard Pump Supplied with HWSBs Only				

⚠ WARNING

ELECTRICAL SHOCK HAZARD – For your safety, turn off electrical power supply before making any electrical connections to avoid possible electric shock hazard. Failure to do so can cause severe personal injury or death.

NOTICE

Wiring must be N.E.C. Class 1.

If original wiring as supplied with the boiler must be replaced, use only type 105°C wire or equivalent.

Boiler must be electrically grounded as required by National Electrical Code ANSI/NFPA 70 – latest edition.

⚠ CAUTION

Label all wires prior to disconnection when servicing controls. Wiring errors can cause improper and dangerous operation.

Installation must comply with:

1. National Electrical Code and any other national, state, provincial, local codes, or regulations.
2. In Canada, CSA C22.1 Canadian Electrical Code Part 1, and any local codes.

5 Electrical connections

Line voltage connections

1. Connect 120 VAC power wiring to the line voltage terminal strip in the junction box, as shown in FIG. 5-1.
2. Provide and install a fused disconnect or service switch (15 AMP recommended) as required by the code (see FIG. 5-1).
3. To activate a system pump, wire as shown in FIG. 5-1. If the motor is larger than 1 HP, you must install a contactor.
4. When connecting power to units which are to be cascaded, each unit must be connected to the same ground connection.

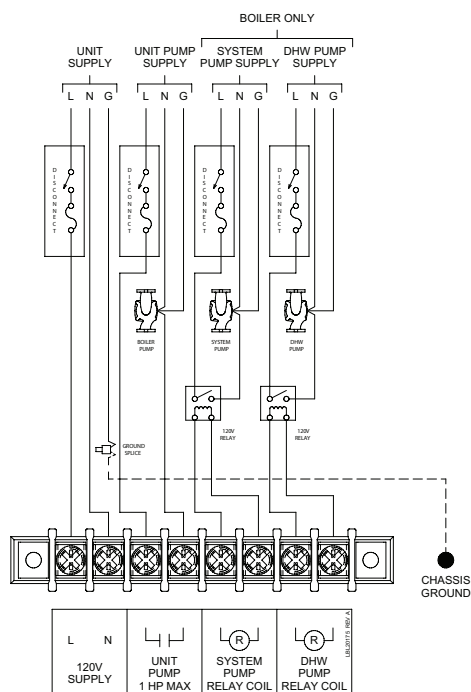

Figure 5-1_Line Voltage Field Wiring Connections

Low voltage connections

1. Route all low voltage wires through the knockouts on the left side of the heater, as shown in FIG. 5-2.
2. Connect low voltage wiring to the low voltage connection board as shown in FIG. 5-4 on page 46 of this manual and the heater wiring diagram.

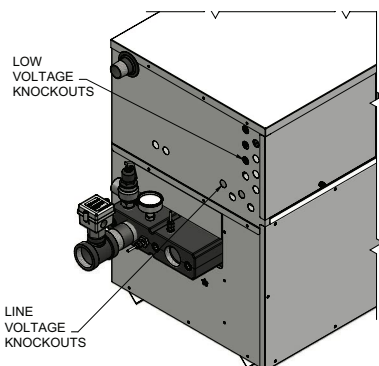

Figure 5-2_Routing Field Wiring

EMS or remote thermostat connection

An EMS, remote thermostat or other remote temperature control may be connected to the boiler (see FIG. 5-3). Follow the manufacturer's instructions supplied with the remote temperature control for proper installation and adjustment. Connection of a set of dry switching contacts or a remote on/off thermostat to the low voltage connection board will allow the unit to be switched on and off by making or breaking a 24 VAC control circuit. Remove the factory jumper between the Staging S1 terminals on the low voltage connection board and connect the remote temperature control in its place, see FIG. 5-4 on page 46.

Ensure that all wiring used to connect the switching contacts of the remote temperature controller to the connection board are a minimum of 18 gauge and have a maximum installed length of 300 feet (91.4m). Set the SMART SYSTEM control to a set point temperature slightly higher than the setting of the remote temperature controller. This will ensure that the remote temperature controller functions as the operating control for the heater.

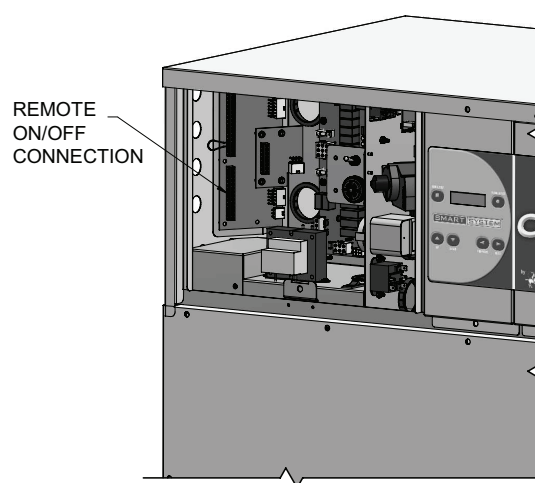

Figure 5-3_Remote ON/OFF Wire Connection

DHW (Domestic Hot Water) thermostat

Connect the DHW tank thermostat (FIG. 5-4) to the tank thermostat terminals on the connection board.

DHW tank sensor

If a tank sensor is used, it must be connected to the tank sensor terminals on the low voltage connection board. The correct Lochinvar sensor (100170544) MUST BE USED.

5 Electrical connections *(continued)*

Louver relay

When the heater is to control combustion air louvers, a field provided 24VAC louver relay must be installed. Connect the Louver Relay Coil terminals to the louver relay coil.

Louver proving switch

The operation of a louver proving switch needs to be verified before the boiler fires. Remove the jumper wire from these terminals and connect them to the normally open contacts on its proving switch (FIG. 5-4).

System supply sensor (recommended use)

1. By installing the system supply sensor into the supply of the primary loop, the temperature of the primary supply can be controlled. The SMART SYSTEM control automatically detects the presence of this sensor, and controls the boiler firing rate to maintain the system supply temperature to the set point (if the outlet sensor control is currently selected).
2. Connect these terminals to the system supply sensor (FIG. 5-4).

System return sensor (optional use)

1. By installing the system return sensor into the return of the primary loop, the temperature of the primary return can be sensed when a 3-way valve or other device is installed ahead of the heater inlet. The SMART SYSTEM control automatically senses the presence of this sensor. If the inlet sensor is selected as the controlling sensor, the SMART SYSTEM control will adjust the firing rate to hold the system return temperature to the set point. In this case, a system supply sensor must be installed for proper operation.
2. Connect these terminals to the system return sensor (FIG. 5-4).

Boiler Management System (BMS)

1. An external control may be connected to control either the firing rate or the set point of the appliance (boiler or hot water supply boiler). Connect the 0 - 10 VDC terminals to the 0 - 10 VDC output of the external control. The SMART SYSTEM control can be programmed to use the enable output of the Boiler Management System, or use the voltage signal to enable the heater. Connect the Staging S1 or tank thermostat terminals to the enable output of the BMS, when used.
2. Make sure the ground terminal is connected to the ground output terminal of the external control, and the 0 - 10 V BMS IN terminal is connected to the 0 - 10 VDC terminal of the external control.

Runtime contacts

The SMART SYSTEM control closes a set of dry contacts whenever the burner is running. This is typically used by Building Management Systems to verify that the boiler is responding to a call for heat.

3-way valve out

An electric 3-way mixing valve may be used when the return temperature to the heater is less than 140°F (60°C). Connect the Open output to the Open terminal on the 3-way valve. Connect the Close output to the Close terminal on the valve and the COM output to the 24VAC terminal on the valve.

0 - 10V rate out

A 0 - 10VDC signal is available to allow a Building Management System (BMS) to monitor the firing rate of the heater. Make sure the (-) terminal is connected to the (-) or common terminal of the external control, and the (+) terminal is connected to the (+) or Vdc terminal of the external control.

0 - 10V system pump in

A 0 - 10VDC input is available so that the boiler can monitor the speed of a variable speed system pump. This allows the boiler to anticipate changes in the heat load as the system flow changes. Connect the (-) terminal to the (-) or common terminal on the system pump VFD drive, and the (+) terminal to the (+) or 0 - 10VDC terminal on the system pump VFD drive. A 0 - 020mA signal may also be used, by adding a 500 ohm resistor between the (+) and (-) terminals.

Sequencer

The individual stages in the heater can be controlled separately with an external sequencer. Connect the Staging S1 terminals to the first stage contacts on the sequencer, the Staging S2 terminals to the second stage contacts, and so forth. Note that the sequencer must enable the stages in order, with Stage 1 first, Stage 2 second and so on.

Alarm contacts

The SMART SYSTEM control closes another set of contacts whenever the heater is locked out or the power is turned off. This can be used to turn on an alarm, or signal a Building Management System that the boiler is down.

5 Electrical connections

Wiring of the cascade

When wiring the heaters for Cascade operation, select one heater as the Leader. The remaining heaters will be designated as Members. See page 51 Configuration of the Cascade for a detailed explanation of this procedure.

On boilers, connect the system supply sensor and outdoor air sensor (if used) to the Leader boiler. The location of the system supply sensor should be downstream of the boiler connections in the main system loop (FIG.'s 4-3 and 4-6). The system supply sensor should be wired to the low voltage connection board at the terminals marked for the system supply sensor (see FIG. 5-4). The Leader control will use the water temperature at the system supply sensor to control the operation of the Cascade.

If outdoor air reset is desired, the outdoor air sensor should be wired to the low voltage connection board at the terminals marked for the outdoor air sensor (FIG. 5-4). If the outdoor air sensor is connected, the Leader control will calculate the water temperature set point based on the programmed reset curve parameters. If the outdoor air sensor is not connected, the Leader control will maintain the space heating (SH) set point that is programmed into the control.

If a Thermostat, Zone Control enable output, or Building Management System enable output are available, it should be wired to the low voltage connection board on the Leader boiler at the Staging S1 terminals. If the boilers are to run continuously, leave the jumper wire between these terminals. This will initiate a call for heat on the Cascade. Also, leave the jumpers on the Staging S1 terminals of all the Member heaters. This will allow them to run independently should the Leader heater fail.

On hot water supply boilers, connect the tank thermostat or BMS enable output to the low voltage connection board on the Leader heater, at the terminals marked for the tank Aquastat. If a tank sensor is used, connect this sensor to the low voltage connection board on the Leader heater, at the terminals marked for the tank sensor.

Communication between the Leader heater and the Member heaters is accomplished by using shielded, 2-wire twisted pair communication cable. Connect one of the twisted pair wires to terminal A on each of the low voltage connection boards, and the other wire of the twisted pair to terminal B on each of the low voltage connection boards. Connect the shield wire to the shield ground terminal on all of the heaters. If more than two heaters are on the Cascade, daisy chain the wiring from the Cascade terminals on the second heater to the Cascade terminals on the third heater, then from the third to the fourth, and so on. The connections can be made in any order, regardless of the addresses of the heaters. Try to keep each cable as short as possible.

Figure 5-4_Low Voltage Field Wiring Connections

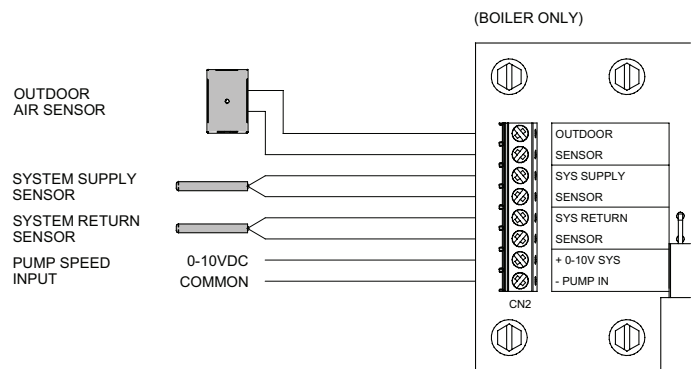
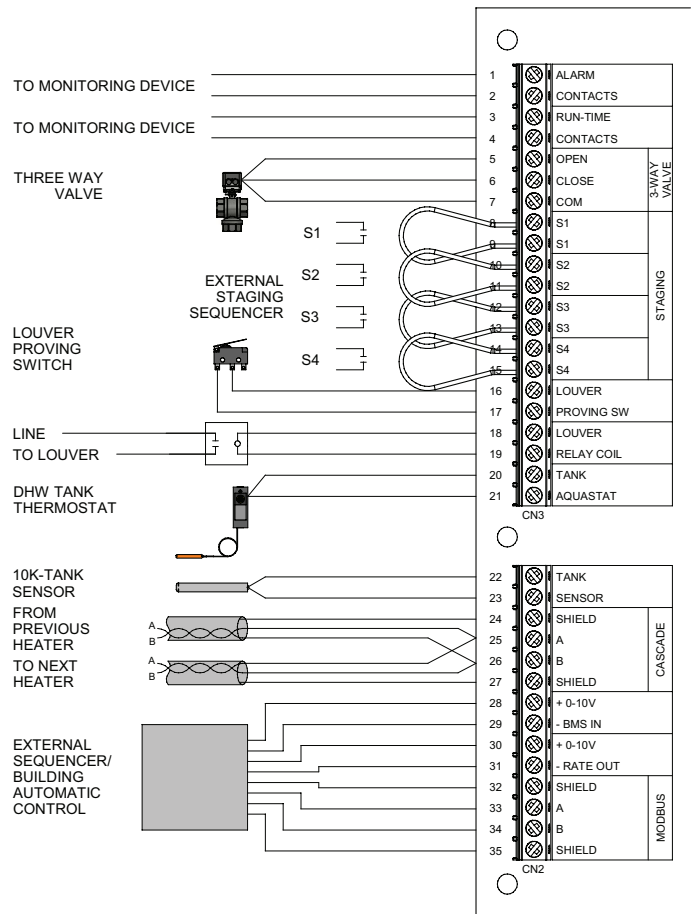

6 Start-up

Pre-Commissioning Cleaning

1. Prior to fill and start-up, flush the entire heating system.
2. Clean the entire heating system with an approved pre-commissioning cleaner (comparable to Sentinel X300 and Fernox F3) in accordance with the manufacturer's recommendation to remove debris and prolong the life of the heat exchanger.
3. Clean all water filtering devices in the system.
4. Flush the cleaning solution out of the entire system and refill.

Fill water

Check/control fill water chemistry

IMPORTANT

Conduct water quality testing prior to installing the appliance. Various solutions are available to adjust water quality.

The manufacturer recommends the following for properly filling your boiler with the appropriate water chemistry for closed loop boilers. Good fill water quality will help extend the life of the appliance by reducing the effects of lime scale buildup and corrosion in closed loop systems.

Hardness between 5 and 15 grains per gallon

1. Consult local water treatment companies for hard water areas (above 15 grains per gallon hardness).
2. Hardness levels that are above 15 grains/gallon can lead to lime scale buildup throughout the boiler system. If the fill water is below 5 grains/gallons, usually due to use of a water softener, it is recommended to mix in some potable water at the inlet to increase the hardness of the water to above 5 grains/gallons.

pH between 6.5 and 8.5

1. pH levels below 6.5 can cause an increase in the rate of corrosion. pH of 8.5 or higher can potentially cause lime scale buildup.

Total Dissolved Solids (TDS) less than 350 ppm

1. Total dissolved solids are all minerals, salts, metals, and charged particles that are dissolved in water.
2. The greater the amounts of TDS present, the higher the corrosion potential due to increased conductivity in the water.

Chloride concentration less than 150 ppm

1. Do not fill boiler or operate with water containing chlorine in excess of 150 ppm.
2. Filling with fresh drinking water should be acceptable.
3. Do not use the boiler to directly heat swimming pool or spa water.

Boiler water

CAUTION

Do not use petroleum based cleaning or sealing compounds in the boiler system. Gaskets and seals in the system may be damaged. This can result in substantial property damage.

CAUTION

DO NOT use "homemade cures" or "boiler patent medicines". Serious damage to boiler, personnel, and/or property may result.

Table 7A Boiler Water Chemistry

BOILER WATER CHEMISTRY	
Specification	Range
Dissolved Solids	< 2000 ppm
pH Level	6.5 to 9.5
Chloride	< 150 ppm

- Monitoring pH, chlorides, TDS, and hardness levels can prolong the life of the appliance by reducing lime scale buildup, corrosion, and erosion. Check for leaks to ensure that fresh water is not entering the system.
- Continual fresh makeup water will reduce boiler life.
- Mineral buildup in the heat exchanger reduces heat transfer, overheats the stainless steel heat exchanger, and causes failure.
- The addition of oxygen carried in by makeup water can cause internal corrosion in system components.
- Leaks in the boiler or piping must be repaired at once to prevent excessive makeup water. For this purpose, it is recommended to install a water meter to easily check the amount of makeup water entering the system. Makeup water volume should not exceed 5% of the total system volume per year. **NOTE:** When makeup water is added, make sure the chemical additives are added to maintain the correct level.
- An approved multi-metal corrosion inhibitor (comparable to Sentinel X100 or Fernox F1) is recommended at the correct concentration and in the manner recommended by the manufacturer.

Freeze protection for a Heating Boiler System (if required)

⚠ WARNING

Ethylene glycol is toxic, DO NOT use as your freeze protection. Ethylene glycol has a sweet aroma which children and pets could mistake as food and ingest; leading to death.

1. Use glycol only if needed for freeze protection.
2. Propylene glycol is the recommended freeze protection.
3. Make sure to flush the boiler system before adding glycol.
4. Determine the freeze protection fluid quantity using system water content, following the fluid manufacturer's instructions. Boiler water content is listed on page 3. Remember to include expansion tank water content.

6 Start-up

5. Local codes may require a backflow preventer or actual disconnect from city water supply.
6. When using freeze protection fluid with automatic fill, it is suggested to install a water meter to monitor water makeup. Freeze protection fluid may leak before the water begins to leak, causing the concentration to drop, which reduces the freeze protection level.
7. The freeze protection set points may be lowered when freeze protection fluid is used (see the Copper-Fin II Service Manual).
8. Consult the glycol manufacturer for details on the suggested mix of glycol and water for the desired freeze protection level and the de-rate effect it will have on the boiler output.

Test / replace freeze protection fluid

1. For systems using freeze protection fluids, follow the fluid manufacturer's instructions.
2. Freeze protection fluid must be replaced periodically due to degradation of inhibitors over time.
3. It is recommended to test the glycol concentration annually and adjust within the desired set points.

Oxygen prevention

CAUTION

Eliminate all system leaks. Continual fresh makeup water will reduce boiler life. Minerals can build up in the heat exchanger, reducing heat transfer, overheating the heat exchanger, and causing heat exchanger failure.

Dissolved oxygen can have a negative effect on the boiler system. Oxygen can cause iron oxide to generate iron deposits. Oxygen may also increase the rate of corrosion on non-stainless steel parts of the system. A low pH level combined with oxygen further enhances its corrosive effects. After boiler installation, check for air leaks in the following areas:

- Suction gasket
- Pump
- Air valve
- O-ring gaskets

Precautions include installing a water meter to evaluate the fresh water volume entering the system (should be no more than 5% system volume). Additional volumes of fresh water could indicate that a leak is present.

Fill and test water system

1. Fill system only after ensuring the water meets the requirements of this manual.
2. Close automatic and manual air vents and boiler drain valve.

3. Fill to correct system pressure. Correct pressure will vary with each application.
 - a. The minimum cold water fill pressure for a system is 12 psi.
 - b. Pressure will rise when the boiler is turned ON and system water temperature increases.
4. At initial fill and during boiler startup and testing, check the system thoroughly for any leaks. Repair all leaks before proceeding further.

Purge air from water system

1. Purge air from system:
 - a. Connect a hose to the purge valve (see purge/drain valve in the piping diagrams on pages 42 through 47). Route the hose to an area where water can drain and be seen.
 - b. Close the boiler or system isolation valve between the purge valve and fill connection to the system.
 - c. Close zone isolation valves.
 - d. Open the quick-fill valve on the cold water makeup line.
 - e. Open purge valve.
 - f. Open the isolation valves one zone at a time. Allow water to run through the zone, pushing out the air. Run until no noticeable air flow is present. Close the zone isolation valves and proceed with the next zone. Follow this procedure until all zones are purged.
 - g. Close the quick-fill water valve and purge valve and remove the hose. Open all isolation valves. Watch that system pressure rises to correct cold-fill pressure.
 - h. After the system has operated for a while, eliminate any residual air by using the manual air vents located throughout the system.
 - i. If purge valves are not installed in the system, open the manual air vents in the system one at a time, beginning with the lowest floor. Close the vent when water squirts out. Repeat with remaining vents.
2. Open the automatic air vent (diaphragm-type or bladder type expansion tank systems only) one turn.
3. Open other vents:
 - a. Starting on the lowest floor, open air vents one at a time until water squirts out.
 - b. Repeat with remaining vents.
4. Refill to correct pressure.

Check for gas leaks

⚠ WARNING Before starting the boiler, and during initial operation, smell near the floor and around the boiler for gas odorant or any unusual odor. Remove the front access panel and smell the interior of the boiler enclosure. Do not proceed with startup if there is any indication of a gas leak. Use an approved leak detection solution. Repair any leaks at once.

⚠ WARNING Propane boilers only – Your propane supplier mixes an odorant with the propane to make its presence detectable. In some instances, the odorant can fade, and the gas may no longer have an odor. Before startup (and periodically thereafter), have the propane supplier verify the correct odorant level in the gas.

6 Start-up *(continued)*

Check thermostat circuit(s)

1. Disconnect the two external wires connected to the enable terminals on the connection board.
2. Connect a voltmeter across these two incoming wires. Close each thermostat, zone valve, and relay in the external circuit one at a time and check the voltmeter reading across the incoming wires.
3. There should NEVER be a voltage reading.
4. If a voltage does occur under any condition, check and correct the external wiring. (This is a common problem when using 3-wire zone valves.)
5. Once the external thermostat circuit wiring is checked and corrected if necessary, reconnect the external thermostat circuit wires to the connection board. Allow the boiler to cycle.

Check vent and air piping

Inspect vent piping and air piping for signs of deterioration from corrosion, physical damage or sagging. Verify air piping and vent piping are intact and correctly installed per this manual.

Placing the boiler in operation

Boiler operational checks

1. Turn the boiler main power switch to the "ON" position.
2. Verify operation of the SMART SYSTEM control module and Operator Interface.
3. Program the adjustable points from the Operator Interface.
4. Push the reset for the low water cutoff (if equipped).
5. Ensure that maximum flow to the boiler does not exceed 55 GPM on Models 402 - 752 and 90 GPM on Models 992 - 2072. Verify by checking temperature rise while burner is firing at 100% of rated input.
6. Install a manometer on the gas supply to the boiler and verify minimum gas supply pressure as the burner fires at 100% of rated input.
7. Verify operation of safeties as necessary (low water cutoff, high limit, gas pressure, etc.,).
8. Verify that all adjustable points in the Operator Interface are set as required.
9. Once the boiler analysis is complete, test the safety shutoff device by turning the manual shutoff valve to the OFF position and ensuring that the boiler shuts down and registers an alarm. Open the manual shutoff valve and reset the control.
10. Place the boiler back into normal operation.

Boiler operation

11. Boiler should begin the start-up process for the sequence of operation.
12. The boiler will ignite at the proper ignition speed and will stage to meet the system demand.
13. Ensure that inlet water temperature does not fall below the specified minimum for the boiler.
14. Based on system demand, boilers may run for an extended period of time at a reduced rate of input to maximize efficiency.

15. As system demand is satisfied, the burner will cycle off and the combustion air blower will run for a post purge operation before the boiler shuts down.

Start the boiler

Read and follow the Lighting Instructions in FIG. 6-1, on page 50.

If boiler does not start correctly

1. Check for loose connections, blown fuse or service switch off?
2. Is external limit control (if used) open? Is boiler water temperature above 200°F (93.3°C)?
3. Is thermostat set below room temperature?
4. Is gas turned on at meter or boiler?
5. Is incoming gas pressure less than 4.5" water column?

If none of the above corrects the problem, refer to the Troubleshooting Section of the Copper-fin II Service Manual.

⚠ WARNING

The venting system must be installed so that it will prevent flue gas spillage and carbon monoxide emissions, which will result in severe personal injury or death.

Set space heating operation (boiler only)

Determine controlling sensor

For space heating systems, the temperature control can be based on one of four sensors; the **inlet**, **outlet**, **system supply sensor**, or **system return sensor**. The SMART SYSTEM control is programmed at the factory to control the temperature of the outlet sensor. The control will automatically switch to the system supply sensor once it is connected. If it is desired to base the temperature control on the inlet sensor, the appropriate parameter must be changed in the control. See the Copper-fin II Service Manual for a detailed explanation of this procedure. The control will automatically switch to the system return sensor once it is connected. It is recommended that a system supply sensor be installed even when using the inlet sensor as the controlling sensor.

Verify space heat circulator mode

The Space Heating Mode controls both the system (primary) pump (if connected), and the boiler (secondary) pump. When the SMART SYSTEM control receives a space heating call for heat, it turns on the system pump. If the boiler is not heating an indirect DHW (Domestic Hot Water) tank, it also turns on the boiler pump. After the space heating call for heat ends, the system pump continues to run for a short period of time. If the boiler pump was running, it continues to run for a short period of time as well. These pump delays are factory set to 30 seconds. If different delays are desired, the appropriate parameters in the control must be changed. See the Copper-fin II Service Manual for a detailed explanation of this procedure.

Set space heating set point temperature

The UP and DOWN keys may be used during normal operation to adjust the space heating set point temperature (see FIG. 7-1 on page 58 of this manual). Once the desired temperature is displayed, press the ENTER/RESET key to save the new setting. If the ENTER/RESET key is not pressed, the new setting will be used for the current heating cycle only. The old setting will become active after the current heating cycle ends.

6 Start-up

Figure 6-1_Lighting Instructions

FOR YOUR SAFETY READ BEFORE OPERATING

WARNING: If you do not follow these instructions exactly, a fire or explosion may result causing property damage, personal injury or loss of life.

- A. This appliance is equipped with an ignition device which automatically lights the burner. Do not try to light the burner by hand.
- B. BEFORE OPERATING smell all around the appliance area for gas. Be sure to smell next to the floor because some gas is heavier than air and will settle on the floor.
- FOR YOUR SAFETY
"WHAT TO DO IF YOU SMELL GAS"
- Do not try to light any appliance.
 - Do not touch any electrical switch; do not use any phone in your building.
 - Immediately call your gas supplier from a neighbor's phone. Follow the gas supplier's instructions.
- If you cannot reach your gas supplier, call the fire department.
- C. Use only your hand to turn the gas control knob. Never use tools. If the knob will not turn by hand, don't try to repair it, call a qualified service technician. Force or attempted repair may result in a fire or explosion.
- D. Do not use this appliance if any part has been under water. Immediately call a qualified service technician to inspect the appliance and to replace any part of the control system and any gas control which has been under water.

OPERATING INSTRUCTIONS

1. STOP! Read the safety information above on this label.
2. Turn off all electric power to the appliance.
3. Open control access panel.
4. This appliance is equipped with an ignition device which automatically lights the burner. Do not try to light the burner by hand.

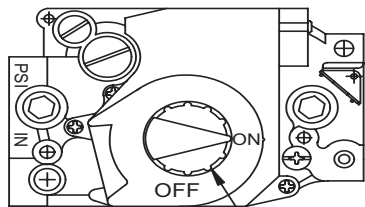

GAS CONTROL KNOB
SHOWN IN THE "ON" POSITION

5. Push in gas control knob slightly and turn clockwise to "OFF."



NOTE: On the 36C valve, knob cannot be turned to "OFF" unless knob is pushed in slightly. Do not force.

6. Wait five (5) minutes to clear out any gas. Then smell for gas, including near the floor. If you smell gas, STOP! Follow "B" in the safety information above on this label. If you don't smell gas, go to the next step".

7. Turn gas control knob counterclockwise to "ON."



8. Replace control access panel.
9. Turn on all electric power to the appliance.
10. If the appliance will not operate, follow the instructions "To Turn Off Gas To Appliance" and call your service technician or gas supplier.

TO TURN OFF GAS TO APPLIANCE

1. Turn off all electric power to the appliance if service is to be performed.
2. Open control access panel.
3. Push in gas control knob slightly and turn clockwise to "OFF". Do not force.
4. Replace control access panel.



LBL2084 REV D

6 Start-up *(continued)*

Set DHW operation

Verify DHW circulator mode (boiler only)

The DHW Mode is programmed to heat an indirect domestic hot water tank. When the tank thermostat or tank sensor calls for heat, the SMART SYSTEM control will turn on the DHW pump and turn off the boiler pump (if running). If the system pump is running, it will remain on. When the DHW call for heat ends, and there is no space heating call for heat, the DHW pump will continue to run for a period of time. This pump delay is set at the factory to 30 seconds. If a shorter or longer delay is desired, the appropriate parameter in the control must be changed. See the Copper-fin II Service Manual for a detailed explanation of this procedure. If there is an active space heating call for heat, then the boiler pump will be turned on and the DHW pump will be turned off.

Set outlet target temperature (boiler only)

When in the DHW Mode, the control will modulate to maintain the outlet temperature to a set point. This set point is set at the factory to 180°F (82.2°C). If a different set point is desired, the appropriate parameter in the control must be changed. See the Copper-fin II Service Manual for a detailed explanation of this procedure.

Set tank target temperature

If a tank sensor is used, the tank set point can be adjusted by pressing either the UP or DOWN key. A menu will appear on the LCD display. Press the DOWN key to select the tank set point, and press ENTER. Use the UP and DOWN keys to adjust the set point. Press the ENTER key again to save the new set point and return to the normal display.

Set clock

The SMART SYSTEM control has a built-in clock that it uses for its night setback feature and for logging events. This clock must be set when the appliance is installed, and anytime the appliance has been powered off for more than one month. Use the following procedure to set the clock:

- Press and hold the MENU key (FIG. 7-1) for at least 5 seconds.
- The display changes to ready "ENTER MENU CODE", with four (4) zeros below it.
- Change the zeros to match the user code (factory set at "0704"). Use the UP and DOWN keys to increment or decrement the flashing digit, and the NEXT and PREVIOUS keys to select which digit flashes.
- Press the ENTER key.
- The display changes to read USER CODE for a few seconds, then displays a menu.
- Press the ENTER key.
- Press the UP key twice to display "A3 DATE AND TIME".
- Press the ENTER key once.
- The date and time are displayed as "YY:MM:DD W hh:mm", where:
 - mm: minutes
 - hh: hour (24 hour time; e.g., 2:00 PM = 14:00)
 - W: day of the week (1 = Sunday, 2 = Monday, 3 = Tuesday, etc.,)
 - YY: year
 - MM: month
 - DD: date

NOTICE

The internal clock does not adjust for Daylight Savings Time and therefore, will require a manual adjustment.

Use the UP and DOWN keys to increment or decrement the flashing number, and the NEXT and PREVIOUS keys to select which number flashes.

- Press the ENTER key to save the setting.
- Press the MENU key twice to exit the Programming Mode.

Configuration of the cascade

When installed in a Cascade system, the individual controls must be programmed for cascade operation. This is accomplished by accessing the control parameters.

Input the Installer code as described in the Copper-fin II Service Manual. Once the control parameters have been accessed, use the DOWN arrow key to select the H Control Mode parameters. Press the ENTER key to access these parameters. Use the UP arrow key to access parameter H4 Cascade. Press the ENTER key to access this parameter. Use the DOWN arrow key to select Enable. Press the ENTER key to program this into the control. Press the EXIT key, then press the DOWN key until I Cascade is selected.

Press the ENTER key to select the parameter I1 BLR Address. Press the ENTER key to access this parameter. Each unit in the Cascade system must be programmed with its own address. The unit designated as the Leader will have an address of 0. The remaining units in the Cascade will be Members and have addresses from 1 - 7. Use the UP and DOWN arrow keys to select the appropriate address. Press the ENTER key to program this into the control.

Press the MENU key twice to exit the control parameters. Repeat this procedure for all appliances in the Cascade, designating the Leader control and the Member controls.

7 Operating information

General

How the appliance operates

The Copper-fin II uses a copper finned tube heat exchanger to transfer heat from the flue products to the water. An electronic control module monitors various inputs to initiate a call for heat. The blower provides both primary and secondary air to the burner and forces the flue products out of the combustion chamber and into the vent system. The control module regulates the blower speed and firing stages, based upon the heat demand. Gas valves regulate the amount of gas supplied for the firing stages, which is then mixed with the combustion air supplied to the burner.

NOTICE

If an inline high gas pressure regulator is used, it **MUST** BE of the lockup type and be located a minimum of 10 feet from the appliance. Failure to do so may result in insufficient gas volume supplied to the appliance.

NOTICE

If a pressure drop of more than 2" water column occurs between Standby (static) Mode and Operating (dynamic) Mode, a gas volume problem exists. Contact the gas utility, gas supplier, qualified installer, or service agency to determine the necessary steps to provide the proper gas volume to the appliance.

How the control module operates

The SMART SYSTEM control module receives input from appliance sensors and external devices. The control module activates and controls the blower and gas valves to regulate heat input and switches the boiler, Domestic Hot Water (DHW), and system pumps on and off as needed. The user programs the module to meet system needs by adjusting control parameters. These parameters set operating temperatures and appliance operating modes. Boiler operation can be based on boiler outlet water temperature, boiler inlet water temperature, system supply temperature, or system return temperature, depending on the parameter setting. When used as a water heater, hot water supply boiler operation can be based on a tank sensor or a tank thermostat.

Control inputs and outputs

Staging S1 - S4

The S1 input tells the boiler to provide water for space heating. The S2 - S4 inputs are used when a sequencer controls the boiler.

Tank Aquastat

This input tells the boiler to provide water for heating a domestic hot water tank.

0 - 10V input (set point or power)

The Copper-fin II can be controlled by a Building Management System (BMS) using a 0 - 10 VDC signal. The control can be configured by the installer to use this signal to either control set point or firing rate.

DHW priority (boiler only)

The SMART SYSTEM control module allows connection of a DHW thermostat or tank sensor to the low voltage connection board. When the DHW thermostat or tank sensor calls for heat, the module activates the DHW pump, shuts down the boiler pump, and immediately sets the target outlet water temperature to 180°F (82.2°C). This provides automatic priority heat allocation to the indirect water heater for maximum response and recovery. The DHW pump continues for 30 seconds after the heating cycle to deliver the most possible heat.

DHW / SH (space heating) cycling (boiler only)

If an indirect DHW call for heat is received while a space heating call is in progress, the control will start the DHW pump and shut the boiler pump off. The system pump will remain on. If the space heating call is still active while the DHW call is in operation, the control will wait for 30 minutes (time adjustable by installer) then it will switch back to the space heating demand. The control will switch back and forth until one of the heat demands end.

7 Operating information *(continued)*

Programmable controlling sensor (boiler only)

The control module is programmed to use the outlet sensor as the control sensor by default. If a system supply sensor is connected, the control automatically uses it as the control sensor. The control sensor can be changed by the installer to the inlet sensor. In this case, if a system return sensor is installed, the control automatically uses it as the control sensor. If the inlet sensor is chosen as the controlling sensor, it is recommended that the system supply sensor be installed for the best system performance.

Anti-cycling (boiler only)

After the set point has been satisfied, the control will delay the next burner cycle for a set time period (time is adjustable by the installer). The time delay will be bypassed if the system return temperature drops too far during the delay.

Boiler, system, and DHW pump control

When a space heating call for heat starts and no DHW call is on, the system and boiler pumps are turned on. As long as the space heating call for heat is on, the system pump will remain on. If a DHW call for heat is on, the boiler pump will wait to turn on until just before the DHW pump turns off. After the space heating call for heat ends, both pumps will run for an additional period of time.

When a DHW call for heat starts, the DHW pump is turned on. If a space heating call for heat was on, the boiler pump will turn off a few seconds after the DHW pump turns on.

Temperature control

Firing rate

Depending upon the model, the Copper-fin II is capable of staging its firing rate from a minimum of 25% to a maximum of 100%. The firing rate is dictated by the call for heat (i.e., space heating or domestic hot water), the heating load, ramp delay (if enabled), and various other temperature limitations.

Ramp delay (boiler only)

For systems with lower flow, the SMART SYSTEM can limit the firing rate (when enabled) when a space heating call for heat starts, or when switching from a DHW call for heat to a space heating call for heat. There are six (6) limits that can be programmed, as well as six (6) time intervals corresponding to each limit. The sixth limit will also limit the firing rate for the rest of the call for heat.

Gradient limiting

If during operation of the heater the outlet water temperature is rising too quickly, the control will reduce the firing rate to its lowest setting.

Outdoor air reset (boiler only)

With the outdoor air sensor connected, the control module will calculate the set point based on the programmed reset curve. The installer can change the slope of the reset curve by several adjustable parameters. The user can limit the maximum set point for the system using the space heating set point.

Boost function (boiler only)

If outdoor air reset is active, and a space heating demand has been active continuously for a set period of time (time adjustable by installer) and there has been no DHW demands, the control may be programmed to increase the set point by a fixed number of degrees (adjustable by installer). This process will repeat until the space heating demand ends, the set point reaches the programmed set point or a maximum of 20 increases has occurred. Once the system heat demand is satisfied, the set point will revert to the value determined by the reset curve.

Night setback

The controller may be programmed to reduce the space heating (boilers) and tank set points during a certain time each day. A start and stop time can be programmed for each day of the week.

7 Operating information

Protection features

Outlet temperature, and temperature rise limiting

The outlet temperature is monitored by the boiler outlet temperature sensor. When the outlet temperature exceeds 230°F (110°C) (boilers) or 190°F (88°C) (hot water supply boilers), the unit will reduce the firing rate. If the outlet water temperature exceeds 235°F (113°C) (boilers) or 200° (93°C) (hot water supply boilers) the control will shut the unit down until it cools off.

The control monitors the temperature difference between the inlet and the outlet sensor. If this difference exceeds the first limit the control will turn off stages. If the temperature difference exceeds a second limit the control will shut the unit down. The unit will restart automatically once the temperature difference has dropped 10°F (6°C) and the minimum off time has expired.

Freeze protection

DO NOT install the appliance in a room likely to freeze.

The following integral feature of the SMART SYSTEM control module provides some protection for the appliance only -- not for the system.

- The SMART SYSTEM control module provides freeze-up protection as follows when the appliance water temperature drops below 45°F (7.2°C):
- Below 45°F (7.2°C), the appliance and system pumps operate constantly.
- Below 37°F (2.7°C), the appliance turns on.
- Appliance and pumps turn off if appliance water temperature rises above 45°F (7.2°C).

CAUTION

This feature of the SMART SYSTEM control module does not eliminate the possibility of freezing. The installer must still use recognized design, installation and maintenance practice to prevent freeze potential for the appliance and system.

High limit operations

When outlet temperature exceeds 240°F (116°C) (boilers) or 210°F (99°C) (hot water supply boilers), high limit action occurs. The appliance shuts down until the outlet water cools down and the RESET button on the Operator Interface is pressed.

Low water cutoff protection

1. The SMART SYSTEM control module uses temperature sensing of both inlet and outlet areas of the heat exchanger. If the flow rate is too low or the outlet temperature too high, the control module modulates and shuts the appliance down. This along with the flow switch, ensures appliance shutdown in the event of low water or low flow conditions.
2. Some codes and jurisdiction may accept these integral features of the control in lieu of requiring an additional limit control or low water cutoff. Consult local jurisdiction to determine. Contact manufacturer for low water cutoff kit availability.

Monitor external limits

Connections are provided on the connection board for external limits such as a louver proving switch. The SMART SYSTEM will shut off the burner and inhibit relighting whenever any of these external limits open.

Run-time and alarm outputs

The appliance provides dry contacts for indicating when the appliance is running, and when it is unable to operate.

Run-time and cycle counting

The control uses two timers to monitor the total hours of burner operation. One timer monitors the time the appliance is firing under 50% of rate. The other timer monitors the time the appliance is firing over 50% rate.

The control uses four (4) ignition counters to monitor the amount of appliance cycles. The first counter counts all ignitions of the control. The second counter counts only ignition attempts that have failed. The third and fourth counters are the same as the first and second respectively, but can be reset by the installer.

Service reminder

The control can be programmed for service reminder notification. This notification will become active when either a set time frame has expired, or a set amount of running hours or cycles has expired (all adjustable by the installer). The display will alternate the standard text on the display screen with Service Due every 5 seconds. The service reminder notification can be reset by the installer.

Error logging

The control will hold in memory the last 10 error codes as well as the last 10 turn-off functions. The date and time of the occurrence will be recorded as well. Only the 10 most current occurrences will be held in memory.

7 Operating information *(continued)*

Boiler temperature regulation

Operating temperature (target)

The SMART SYSTEM control module senses water temperature and regulates appliance firing and firing rate to achieve a target temperature. The target temperature can be set between 70°F (21°C) and 220°F (104°C) (boilers) or between 60°F (16°C) and 190°F (88°C) (hot water supply boilers).

- Target temperature is fixed when the outdoor sensor is not installed (boilers).
- Target temperature is calculated as described under “Outdoor Air Reset Operation” and “Boost Function” when the outdoor sensor is connected (boilers).

Outdoor reset operation, if used (boilers only)

Target temperature with outdoor reset

This feature improves the system’s efficiency as the outdoor temperature warms up.

See the Copper-fin II Service Manual to change the settings.

Reset curve

The reset curve looks at outdoor air temperature and adjusts the set point.

Cascade

When multiple appliances are installed, they can be wired together in a cascade sequence. A maximum of eight appliances can be controlled from a single control. In this application one appliance would be designated as the Leader control and all others would be designated as Member controls. The set point or firing rate can be controlled by the 0 - 10V input as well.

Once the Leader appliance receives a call for heat from a BMS, tank sensor, or external thermostat, the control will determine what the set point will be. A fixed temperature set point can be programmed into the control. See Copper-fin II Service Manual to program the set point.

On boilers, if the water temperature at the system sensor is less than the set point + the turn-off offset - the off-on differential, then the control will initiate a call for heat on the Cascade (see the Copper-fin II Service Manual for an explanation of the offset and differential). The Leader will energize the lead appliance on the Cascade. For a new startup this will be the Leader appliance.

On hot water supply boilers, if the water temperature at the tank sensor is less than the tank set point - the off differential, then the control will initiate a call for heat on the Cascade.

The appliance will fire at its ignition speed and will then stage its firing rate to maintain the set point. If the first appliance reaches 100% of its firing rate, the Leader will calculate at what point the second appliance could fire at its minimum firing rate. At this point, the Leader will fire the second appliance on the Cascade. For a new startup, this would be the first Member appliance. The appliance will fire at its ignition speed and will then staging its firing rate to maintain the set point.

If the set point still cannot be met, the Leader will continue firing more Members until either the heat demand is met or all appliances on the Cascade are firing. As the heat demand decreases, the last appliance on will stage down to its minimum firing rate. Once the demand for that appliance is 0% it will shut down. As the heat demand decreases further, the second to last appliance will stage down and shut off. This will continue until the demand is satisfied and all appliances are shut off.

Sequence of the cascade

To equalize the run time of all appliances on the Cascade, the firing sequence will automatically be changed at set intervals.

For the first 24 hours after initializing the Cascade, the sequence will be changed every hour. After that the sequence will be changed once every 24 hours. The switching on/off sequence will be as follows:

DAY	SWITCHING ON SEQUENCE
Start	L-M1-M2-M3-M4-M5-M6-M7
+ 1 hour	M1-M2-M3-M4-M5-M6-M7-L
+ 2 hour	M2-M3-M4-M5-M6-M7-L-M1

7 Operating information

DHW, Night Setback, and Ramp Delay operation with cascade

For indirect DHW operation any boiler(s) in the Cascade can be selected to provide heat for a DHW call. Select a boiler to be designated as the DHW boiler. Connect the tank thermostat or tank sensor to the corresponding terminals on the low voltage connection board. When the boiler receives a DHW call, the Leader control will take that boiler out of the Cascade sequence. If another boiler is available, the Leader will start it up to take its place.

The DHW boiler will adjust its set point to the programmed outlet set point and will adjust its firing rate to maintain this. Once the DHW call has been satisfied, the Leader control will place that boiler back into the Cascade sequence.

Switching of the boiler between DHW operation and SH operation when there is a call for both does not occur. The boiler will provide heat for the DHW demand until it is satisfied.

Night Setback operation of the boilers or hot water supply boilers within the Cascade is available. Programming of the Space Heating (SH) Night Setback will be done through the Leader boiler. Refer to the Copper-fin II Service Manual for information regarding Night Setback.

Ramp Delay operation of the boilers as described in the Copper-fin II Service Manual is available when the boilers are part of a Cascade system.

7 Operating information *(continued)*

Sequence of operation

OPERATION	DISPLAY
1. The manual reset high limit must be closed before any action will take place.	HTR: Standby OUT: 123.8F (129)
2. Upon a call for heat the control turns on the appropriate pumps (system and boiler pumps for space heating; DHW pump for DHW call). The flow switch and low water cutoff (if equipped) must close.	HTR: Standby OUT: 123.8F (129)
3. <ul style="list-style-type: none"> • If the unit is equipped with a proof of closure valve, the proof of closure switch must be closed. The proof of closure valve is then energized. The gas pressure switch(es) (if equipped) must close. • If the contact for the louvers is closed, the louver proving, and auto reset high limit (hot water supply boiler only) inputs must close. • If the air pressure switch is open, the prepurge cycle then begins by starting the combustion blower. Once started, the air pressure switch must close. 	HTR: Standby OUT: 123.8F (129)
4. After prepurge, the blower slows down and the hot surface ignitor (HSI) is energized.	HTR: PREPURGE OUT: 123.9F (129)
5. Once the HSI is hot, the trial for ignition begins with the opening of the gas valve.	HTR: IGNITION OUT: 123.9F (129)
6. If the SMART SYSTEM control does not sense flame, then it will lock out.	HTR: POSTPURGE, LOCKOUT OUT: 123.9F (129)
7. If the SMART SYSTEM control senses flame, it will fire the burner to maintain the set point. The firing rate will stage as required to hold the actual temperature at the set point. If the boiler lights due to a space heating call for heat, and the ramp delay function is active (default is disabled), the staging will be held to a series of increasing limits after the burner has lit.	HTR: RUN STG: 1 OUT: 124.8F (129)
8. If the space heating call for heat is active, and a DHW call for heat becomes active, the control will turn on the DHW pump and then turn off the boiler pump (boiler and DHW pump operation briefly overlap to ensure that flow is maintained throughout the unit). This will divert the hot water away from the heating zone(s) and send it to the DHW tank instead. The control will then modulate to maintain the outlet temperature to the DHW boiler set point.	HTR: DHW STG 123 OUT: 177.8 (180)
9. If the DHW call for heat remains active for more than 30 minutes, and the space heating call for heat is also on, then the control will turn on the boiler pump, turn off the DHW pump and resume firing based on the space heating set point (boiler and DHW pump operation briefly overlap to ensure that flow is maintained throughout the unit). As long as both the space heating and DHW calls for heat remain active, the control will switch back and forth between the two modes until one of them is satisfied.	HTR: RUN STG 12 OUT: 123.0F (129)
10. Once both calls for heat are satisfied, the control will turn off the burner. The blower will remain on for the postpurge cycle. Any pumps that are running will continue to run for their respective pump delay times, then turn off.	HTR: POSTPURGE OUT: 127.4F (129)
11. Boiler pump off, system pump continues its delay if longer.	HTR: Standby OUT: 124.7F (129)
12. System pump off.	HTR: Standby OUT: 122.9F (129)

7 Operating information

SMART SYSTEM™ Copper-fin II control module

Use the control panel (FIG. 7-1) to set temperatures, operating conditions, and monitor appliance operation.

Figure 7-1_Control Panel - Operator Interface

- Hold 5 seconds to enter code Input Mode (Menu Mode)
- Press to move up one level in Menu Mode or to exit Menu Mode
- 2-Line / 16 character LCD display
- Backlit LCD
- Press to turn heater off or back on
- Press to select a menu item
- Press after parameter programming to store parameter data
- Press to exit Service Mode

MENU/EXIT



DISPLAY SCREEN



ENTER/RESET

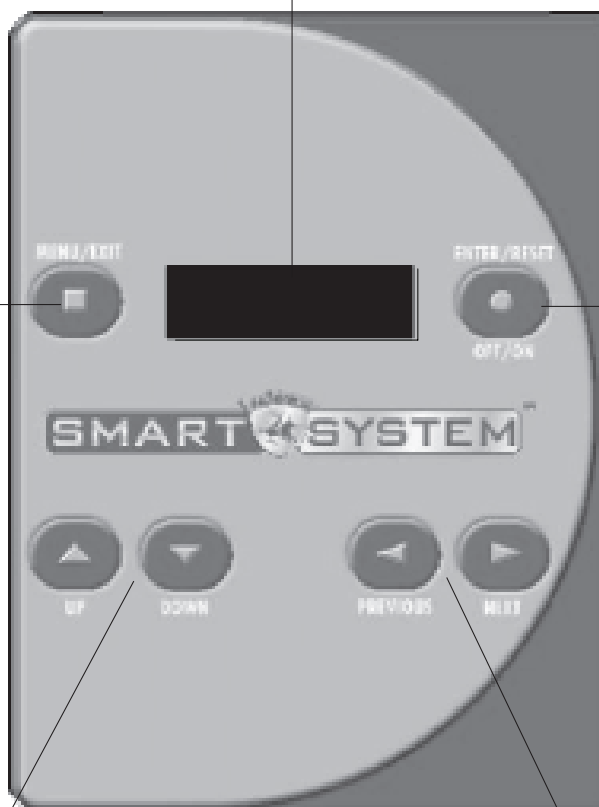

UP



DOWN



PREVIOUS



NEXT

- Press to change boiler water temperature and/or tank water temperature set point during normal operation
- Press to change displayed data values in Menu Mode
- Press to navigate through menu listing in Menu Mode

- Press to toggle display during normal operation to show outlet and return temperatures, fan speed, flame signal, etc.
- Press to toggle between digits when entering access code or between hour, minutes, etc., when entering date and time
- Press and hold both to enter Service Mode

7 Operating information *(continued)*

Access modes

User

The user can adjust the space heating target temperature and the tank target temperature (if a tank sensor is used) by using the UP and DOWN buttons (FIG. 7-1) at any time during normal operation. By entering the USER code (0704), the user can also change temperature units, time and date, and night setback settings. In User Mode, the following parameters can be viewed but not changed:

- Boiler outlet water target temperature in DHW Mode
- Appliance model number
- Software version
- Total operating hours
- Total cycles

Installer

Most parameters are available only to the installer, accessible only by entering the installer access code, see the Copper-fin II Service Manual.

Saving parameters *(reference the Parameter Table in the Copper-fin II Service Manual)*

To save parameters and exit programming:

Press the ENTER/RESET button, then the MENU/EXIT button 3 times.

To keep parameter settings only for a current operating cycle:

Press the MENU/EXIT button 3 times after making all desired parameter changes.

To enter a parameter and continue programming:

Press the MENU/EXIT button 1 time to return to the parameter listings; press again to return to the menu listings. Remember to press the ENTER/RESET button when finished programming in order to save the changes made.

See the Copper-fin II Service Manual for a detailed description of parameters and access modes.

7 Operating information

Status display screens

Status Display Screens		
By using the Previous/Next (◀, ▶) arrow keys on the SMART SYSTEM display panel, you can navigate through the 11 display screens. Each screen will contain two (2) viewable items. The following is a description of the individual items and what they can display:		
Screen #	Display Shows	Description
Screen #1 Line 1	HTR: OFF	The unit has been turned OFF by the Enter/Reset button on the SMART SYSTEM display panel.
	HTR: STAND-BY	The unit has not received a call for heat from a remote thermostat nor has it received a call for heat from a DHW thermostat.
	HTR: SETPOINT MET	The unit has met the water temperature set point, but is still receiving a call for heat from either a remote thermostat, a DHW thermostat, or a BMS.
	HTR: PRE-PURGE	The unit has initiated the pre-purge upon a call for heat.
	HTR: IGNITER * ON	The unit has begun the heatup time prior to the trial for ignition. Display will show IGNITOR A or IGNITOR B depending on which stage has priority.
	HTR: RUN STG **** Or HTR: DHW STG ****	The unit has fired and is running at the displayed number of stages (1,2,3,4)
	HTR: POST-PURGE	The call for heat has been satisfied and the unit runs the fan for an additional post-purge period to clear the combustion chamber and vent system of residual flue products.
	HTR: SERVICE MODE	The unit has been placed in a temporary mode that will allow the unit to fire for the purpose of combustion analysis.
Screen #1 Line 2	OUT: ***F (***)	When the outlet sensor has been selected as the control sensor (default), the control will display the outlet temperature as well as the set point in parenthesis.
	OUT: ***F	If the outlet sensor has not been selected as the control sensor or a system supply sensor is connected, only the outlet temperature will be displayed.
	OUT: OPEN	The control does not detect the outlet sensor.
	OUT: SHORTED	The outlet sensor wires or the sensor itself has become shorted.
Press the Next ▶ arrow key on the SMART SYSTEM display to access Screen #2.		

7 Operating information *(continued)*

Status Display Screens *(cont'd)*

By using the Previous/Next (◀, ▶) arrow keys on the SMART SYSTEM display panel, you can navigate through the 11 display screens. Each screen will contain two (2) viewable items. The following is a description of the individual items and what they can display:

Screen #	Display shows:	Description
Screen #2 Line 1	INLET: ***F (***)	When the inlet sensor has been selected as the control sensor, the control will display the inlet temperature as well as the set point in parenthesis.
	INLET: ***F	If the inlet sensor has not been selected as the control sensor or a system return sensor is connected, only the inlet temperature will be displayed.
	INLET: OPEN	The control does not detect the inlet sensor.
	INLET: SHORTED	The inlet sensor wires or the sensor itself has become shorted.
Screen #2 Line 2	RISE: ***F	The difference between the inlet temperature and the outlet temperature is displayed.
Press the Next ▶ arrow key on the SMART SYSTEM display to access Screen #3.		
Screen #3 Line 1	SYSSUP: ***F (***)	When the system supply sensor has been selected as the control sensor, the control will display the system supply temperature as well as the set point in parenthesis.
	SYSSUP: ***F	If the system supply sensor has not been selected as the control sensor, only the system supply temperature will be displayed.
	SYSSUP: OPEN	The control does not detect the system supply sensor.
	SYSSUP: SHORTED	The system supply sensor wires or the sensor itself has become shorted.
Screen #3 Line 2	SYSRTN: ***F (***)	When the system return sensor has been selected as the control sensor, the control will display the system return temperature as well as the set point in parenthesis.
	SYSRTN: ***F	If the system return sensor has not been selected as the control sensor, only the system return temperature will be displayed.
	SYSRTN: OPEN	The control does not detect the system return sensor.
	SYSRTN: SHORTED	The system return sensor wires or the sensor itself has become shorted.
Press the Next ▶ arrow key on the SMART SYSTEM display to access Screen #4.		
Screen #4 Line 1	OUTDOOR: ***F	The control will display the outdoor air temperature as sensed by the outdoor air sensor.
	OUTDOOR: OPEN	The control does not detect the outdoor air sensor.
	OUTDOOR: SHORTED	The outdoor air sensor wires or the sensor itself has become shorted.
Screen #4 Line 2	TANK: ***F	The control will display the tank temperature as sensed by the tank sensor.
	TANK: OPEN	The control does not detect the tank sensor.
	TANK: SHORTED	The tank sensor wires or the sensor itself has become shorted.

7 Operating information

Status Display Screens (cont'd)

By using the Previous/Next (◀, ▶) arrow keys on the SMART SYSTEM display panel, you can navigate through the 11 display screens. Each screen will contain two (2) viewable items. The following is a description of the individual items and what they can display:

Screen	Display shows:	Description
Press the Next ▶ arrow key on the SMART SYSTEM display to access Screen #5.		
Screen #5 Line 1	0 – 10V BMS: **. *V	The control displays the BMS voltage input from 0 to 10 volts.
Screen #5 Line 2	STG DEMAND: ****	The control displays the number of stages being called by the control.
Press the Next ▶ arrow key on the SMART SYSTEM display to access Screen #6.		
Screen #6 Line 1	FAN SPEED: ***	The control will display either OFF, LOW, or HIGH depending upon fan speed requirements of number of stages firing.
Screen #6 Line 2	0 – 10V RATE: **. *V	The control will display 0 to 10 volts based upon the number of stages firing.
Press the Next ▶ arrow key on the SMART SYSTEM display to access Screen #7.		
Screen #7 Line 1	SH CFH: ***	The control will display either ON or OFF based upon a demand (call for heat) for space heating.
Screen #7 Line 2	WHR CFH: ***	The control will display either ON or OFF based upon a demand (call for heat) for DHW (domestic hot water).
Press the Next ▶ arrow key on the SMART SYSTEM display to access Screen #8.		
Screen #8 Line 1	SYS PUMP: ***	The control will display either ON or OFF based upon system pump requirements upon demand for space heating.
Screen #8 Line 2	SYSPUMPSPD: **. *V	The control will display the 0 – 10V input voltage from the system pump based upon system pump speed.
Press the Next ▶ arrow key on the SMART SYSTEM display to access Screen #9.		
Screen #9 Line 1	UNIT PUMP: ***	The control will display either ON or OFF based upon unit pump requirements upon demand for space heating.
	UNIT PUMP: DELAY	The control will display delay in unit pump operation after the space heating requirements have been satisfied.
Screen #9 Line 2	DHW PUMP: ***	The control will display either ON or OFF based upon unit pump requirements upon demand for DHW.
	DHW PUMP: DELAY	The control will display delay in unit pump operation after the DHW requirements have been satisfied.

7 Operating information *(continued)*

Status Display Screens *(cont'd)*

Operation of the cascade

The boiler designated as the Leader will have two additional display screens that can be viewed. These screens will provide information regarding the operation of the Cascade. Each screen will contain two viewable items. The following is a description of the individual items and what they can display:

Screen	Display shows:	Description
Press the Next ► arrow key on the SMART SYSTEM display to access Screen #10.		
Screen #10 Line 1	FLM SIG – A: **. * μA	The control displays the igniter flame signal of igniter A in microamps.
Screen #10 Line 2	FLM SIG – B: **. * μA	The control displays the igniter flame signal of igniter B in microamps.
Press the Next ► arrow key on the SMART SYSTEM display to access Screen #11.		
Screen #11 Line 1	IGN * AMPS: *. * A	The control displays the current of either igniter A or B.
Screen #11 Line 2	MIX VAL POS: **. %	The control displays the mixing valve percentage open to the system.

8 Domestic water heater application

This section applies only to those appliances used to supply domestic hot water, installed with a storage tank(s). A circulating pump **MUST** be installed in the piping assembly to the storage tank and valves used to control water velocity through the appliance. Proper water velocity is important for correct operation of your hot water supply boiler.

This section contains specific instructions for those appliances used to supply domestic hot water. All warnings, cautions, notes and instructions in the general installation and operation sections apply to these instructions. Hot water supply boilers are designed for installation with a storage tank. The operation of the circulating pump, proper sizing of the piping between the tank and heater, and the control of water velocity, as explained in this section, are important for correct operation of your hot water supply boiler.

NOTICE

To ensure proper velocity through the heat exchanger, it is necessary to regulate the temperature rise across the heat exchanger from inlet to outlet. This must be done on initial installation and periodically rechecked. With the correct temperature rise across the heat exchanger when the hot water supply boiler is firing at 100% of rated input, you may be assured of the proper velocity in the tubes. This will yield long life and economical operation from your hot water supply boiler.

Excessive lime/scale build-up in the heat exchanger tubes is a result of restricted flow and too little velocity in the tubes. Excessive pitting or erosion in the tube is caused by high water flow and too much velocity through the tubes. Care should be taken to measure temperature rise and maintain velocity as follows:

Initial set-up of maximum water flow

On initial start-up of the Copper-fin II the maximum water flow through the heat exchanger must be manually set before normal operation begins.

TABLE - 8A
MAXIMUM FLOW FOR HEATING BOILER

The maximum flow rate through the boiler with a copper heat exchanger must not exceed the following:

Model	Maximum Flow	Maximum Flow for CuNi Heat Exchanger
402, 502, 652, and 752	55 GPM	75 GPM
992, 1262, 1442, 1802, and 2072	90 GPM	115 GPM

The heat exchanger is capable of operating within the design flow rates required for the hot water supply boiler, storage tank(s), and connecting piping. Erosion of the finned copper tubes may occur if the flow rate exceeds the maximum allowable flow rate through the hot water supply boiler. The maximum flow rate through the hot water supply boiler must be adjusted. Maximum flow on Models 402 - 752 is 55 GPM and 90 GPM on Models 992 - 2072. Flow rate can be determined by measuring the temperature rise through the hot water supply boiler when it is firing at full rate input.

TABLE - 8B
TEMPERATURE RISE AT FULL RATE FIRE
55 AND 90 GPM FLOW

Model	Temperature Rise °F
402	12
502	15
652	20
752	23
992	19
1262	24
1442	27
1802	34
2072	39

1. The pump must run continuously when the burner is firing.
2. With the pump running and the burner in the hot water supply boiler in the off cycle, the inlet water temperature and outlet water temperature readings on the Operator Interface should read approximately the same temperatures. Water Temperature Rise on the Operator Interface should read near zero.
3. Turn the hot water supply boiler on and allow time for the temperature to stabilize. The Service Mode can be used to force the hot water supply boiler to run at full fire. See the Copper-fin II Service Manual for a detailed explanation of the Service Mode. Check the water temperature rise in the Operator Interface when the burner is firing at 100% of rated input.
4. Compare the water temperature rise in the Operator Interface with the required temperature rise. Should adjustment be needed, proceed as follows.

8 Domestic water heater application *(continued)*

If the temperature rise is too high, the water velocity is too low, adjust as follows:

1. Check for restrictions in the outlet of the hot water supply boiler.
2. Be sure all valves are open between the hot water supply boiler and the storage tank. Ensure that all ball valves are fully ported.
3. Check the pump to be sure it is running properly and that the pump motor is running in the proper direction.
4. Check diameter and length of the piping between the storage tank and hot water supply boiler against the head capacity of the circulating pump.
5. Be sure the pipes between the hot water supply boiler and storage tank are not less than 2 or 2 1/2 inch (63.5mm) diameter (depending on model). To increase flow and decrease temperature rise, increase the piping to 3 inch (76.2mm) diameter (depending on model) to decrease head loss in the piping to the storage tank.
6. Common manifold piping for multiple unit installations will require larger minimum pipe sizes and tank circulating tappings to ensure proper flow.

If the temperature rise is too low, the water velocity is too high, adjust as follows:

1. Temperature rise can be increased by slowly closing the field-installed ball valve in the outlet piping from the hot water supply boiler to the storage tank to achieve the proper temperature rise.
2. Sustained high water velocity and low temperature rise may result in pitting or erosion of the copper tubes in the heat exchanger. This is a non-warrantable failure. Temperature rise must be properly adjusted to achieve the specified flow rate.
3. Once temperature rise has been properly set, return to normal operation.

⚠ CAUTION

Temperature rise cannot be adjusted when the burner is firing at less than 100% of rated input.

Water chemistry

NOTICE

Water temperature rise and maximum flow data is based on heating potable water with a hardness of 5 to 20 grains per gallon and total dissolved solids not exceeding 350 ppm.

The required temperature rise and the standard circulating pump are sized based on the heating of potable water with a hardness of 5 to 20 grains per gallon and a total dissolved solids not exceeding 350 ppm. Consult the manufacturer when heating potable water exceeding these specifications. Heating of high hardness and/or high total dissolved solids water may require a larger circulating pump, an optional Cupro Nickel heat exchanger and a revised temperature rise specification based on the water chemistry of the water to be heated. Water with a hardness of less than 5 grains per gallon will usually have a pH which can be aggressive and corrosive causing non-warrantable damage to the heater, pump, and associated piping. Corrosion due to water chemistry generally shows up first in the hot water system because heated water increases the rate of corrosive chemical reactions.

NOTICE

1. Do not use the appliance to directly heat swimming pool or spa water.
2. At initial fill and during water heater start-up and testing, check system thoroughly for any leaks. Repair all leaks before proceeding further.
3. When water hardness levels are less than 5 gpg or 85.5 mg/l, the following is recommended:
 - a. Flush and clean existing water heating system prior to installation.
 - b. Inspect and, if necessary, replace the anodes in any existing tanks.
 - c. Install a Y-strainer on the inlet of each water heater as detailed in this section.
 - d. Limit the run time of the hot water recirculation loop.
 - e. Filter the hot water recirculation loop to a level of 10 microns. CAUTION: Check recirculation pump size to verify it is sized for filter addition and upsize if necessary.
4. When water softener is required, a Template Assisted Crystallization system is recommended.

8 Domestic water heater application

Figure 8-1_Typical Water Heater Application Piping with Storage Tank

COMMON MANIFOLD SIZE (Min.) Models: 402, 502, 652, & 752		
Number of Units	GPM	Diameter (in.)
1	55	2

COMMON MANIFOLD SIZE (Min.) Models: 992, 1262, 1442, 1802 & 2072		
Number of Units	GPM	Diameter (in.)
1	90	2 1/2

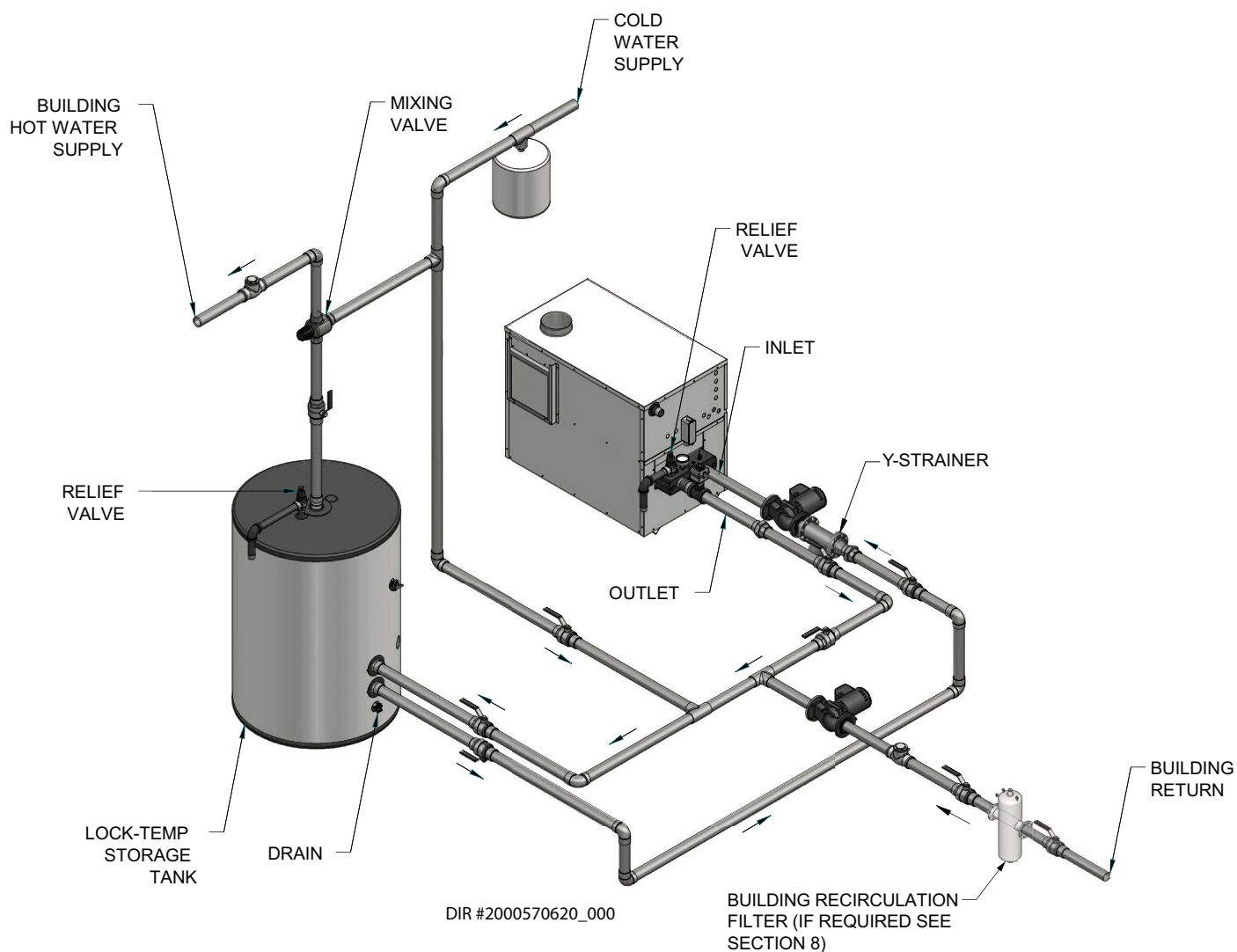

NOTICE

Please note that these illustrations are meant to show system piping concept only, the installer is responsible for all equipment and detailing required by local codes.

8 Domestic water heater application *(continued)*

Figure 8-2_Single Water Heater Application Piping with Two Storage Tanks

COMMON MANIFOLD SIZE (Min.) Models: 402, 502, 652, & 752		
Number of Units	GPM	Diameter (in.)
1	55	2

COMMON MANIFOLD SIZE (Min.) Models: 992, 1262, 1442, 1802 & 2072		
Number of Units	GPM	Diameter (in.)
1	90	2 1/2

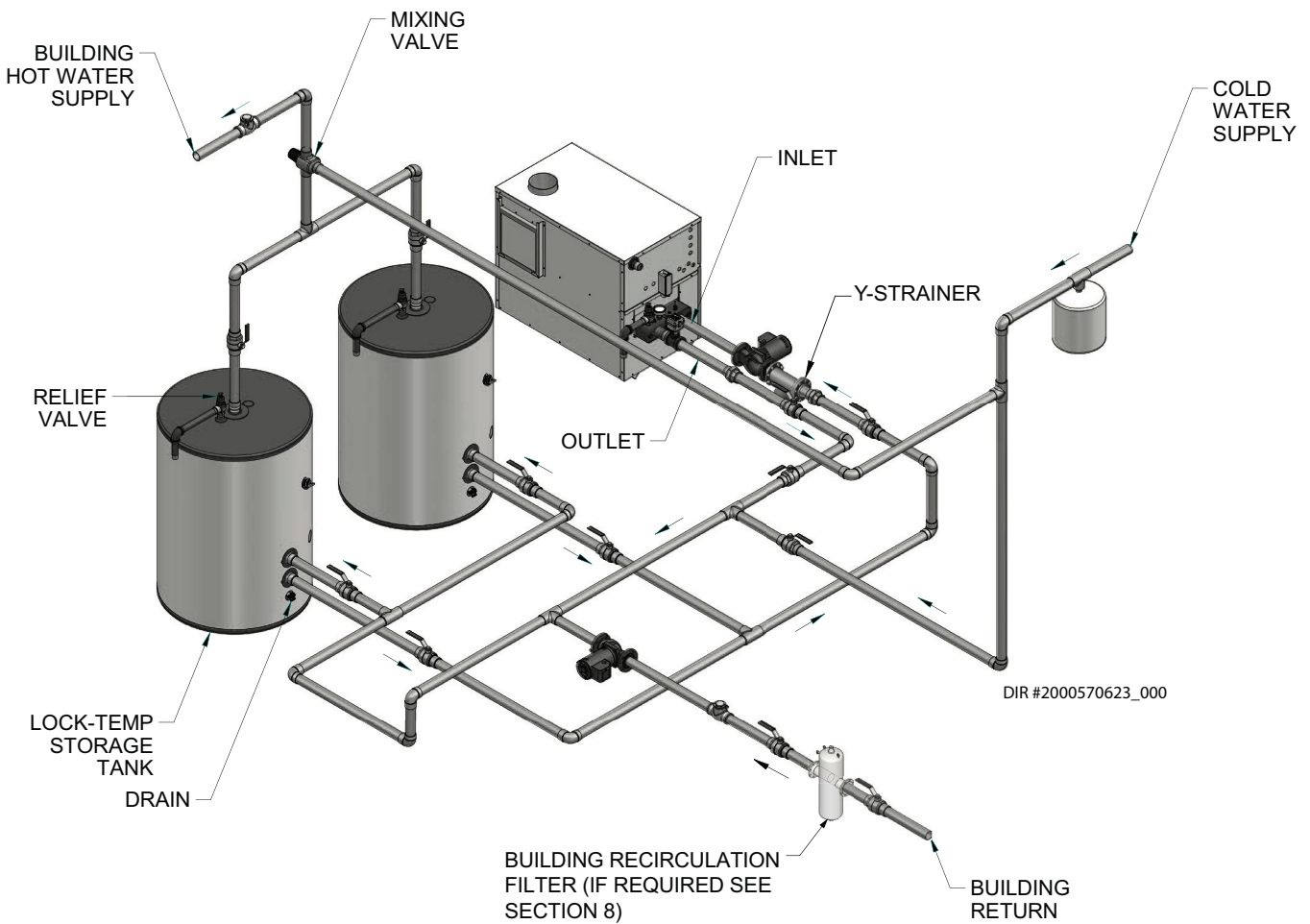

NOTICE Please note that these illustrations are meant to show system piping concept only, the installer is responsible for all equipment and detailing required by local codes.

8 Domestic water heater application

Figure 8-3_Multiple Water Heater Application Piping with a Single Storage Tank

COMMON MANIFOLD SIZE (Min.) Models: 402, 502, 652, & 752		
Number of Units	GPM	Diameter (in.)
2	110	3
3	165	3 1/2
4	220	4
5	275	5
6	330	5
7	385	6
8	440	6

COMMON MANIFOLD SIZE (Min.) Models: 992, 1262, 1442, 1802 & 2072		
Number of Units	GPM	Diameter (in.)
2	180	4
3	270	5
4	360	6
5	450	6
6	540	6
7	630	7
8	720	7

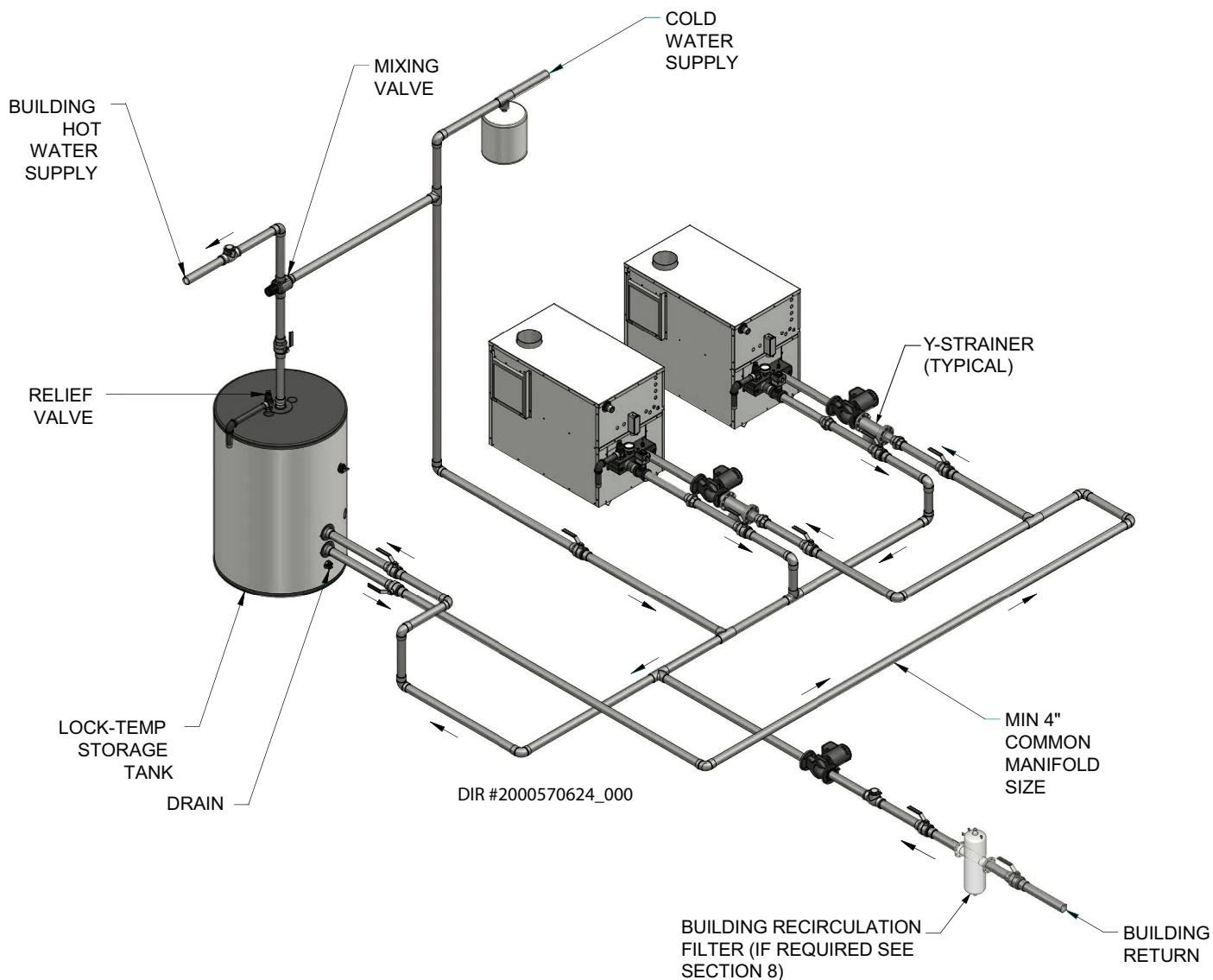

NOTICE Please note that these illustrations are meant to show system piping concept only, the installer is responsible for all equipment and detailing required by local codes.

8 Domestic water heater application *(continued)*

Figure 8-4 Multiple Water Heater Application Piping with Multiple Storage Tanks

COMMON MANIFOLD SIZE (Min.) Models: 402, 502, 652, & 752		
Number of Units	GPM	Diameter (in.)
2	110	3
3	165	3 1/2
4	220	4
5	275	5
6	330	5
7	385	6
8	440	6

COMMON MANIFOLD SIZE (Min.) Models: 992, 1262, 1442, 1802 & 2072		
Number of Units	GPM	Diameter (in.)
2	180	4
3	270	5
4	360	6
5	450	6
6	540	6
7	630	7
8	720	7

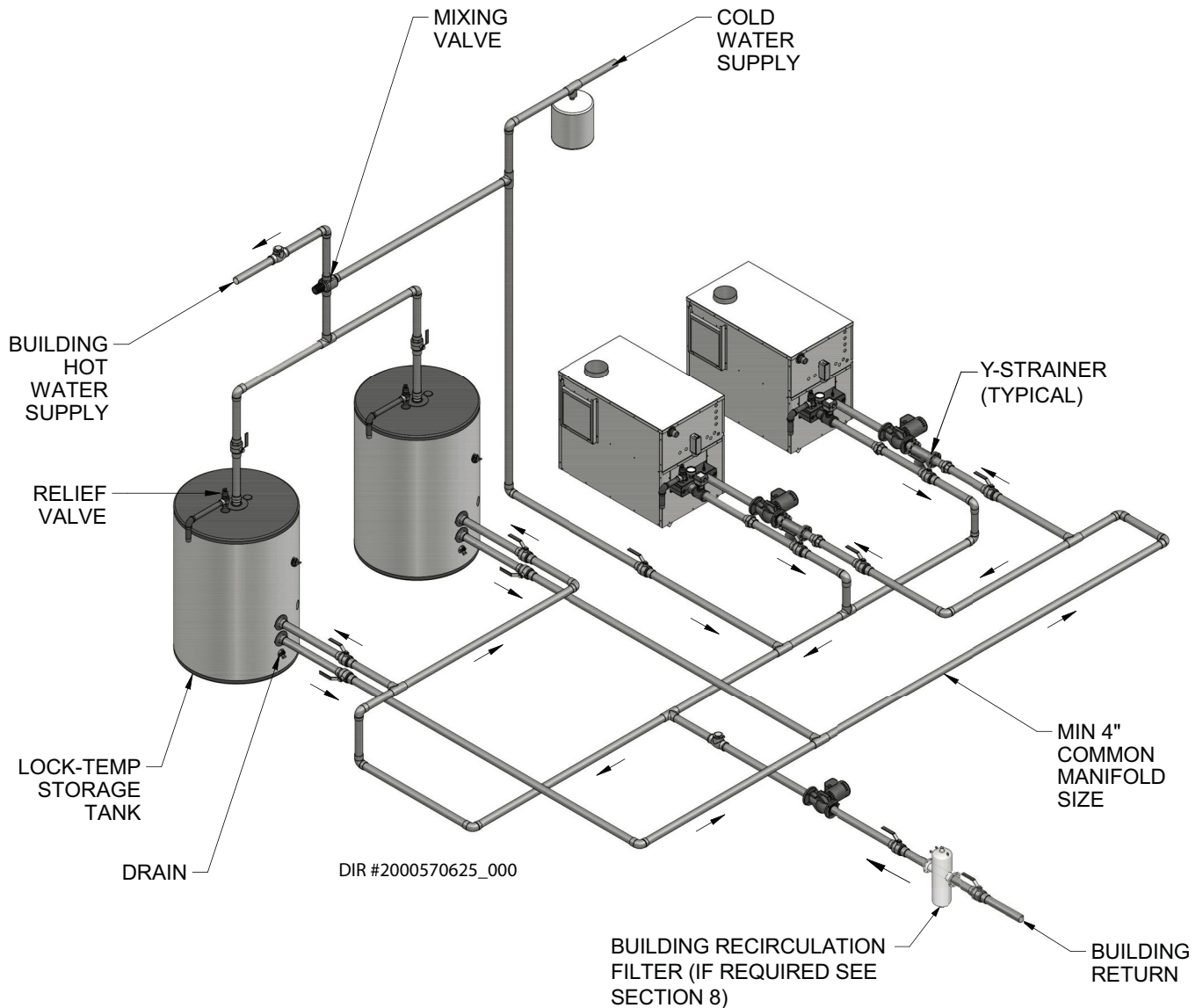

NOTICE Please note that these illustrations are meant to show system piping concept only, the installer is responsible for all equipment and detailing required by local codes.

8 Domestic water heater application

TABLE 8C

COMMON WATER MANIFOLD SIZE FOR
MULTIPLE HOT WATER SUPPLY BOILER
INSTALLATIONS

Pipe sizing chart provides minimum pipe size for common manifold piping to ensure adequate flow.		
Number of Hot Water Supply Boilers	Common Manifold Size (Min.) Models	
	402 - 752	992 - 2072
1	2"	2 1/2"
2	3"	4"
3	3 1/2"	5"
4	4"	6"
5	5"	6"
6	5"	6"
7	6"	7"
8	6"	7"

Pump operation

- The hot water supply boiler must have a properly sized circulating pump. This pump is sized to circulate water between the heater and the storage tank only.
- The pump is sized to the heater input and water chemistry specifications noted in the Water Chemistry section on page 65.
- The diameter and length of the piping installed between the storage tank(s) and hot water supply boiler must be properly sized based on the capacity of the circulating pump.
- The pump must run continuously when the hot water supply boiler is energized. This is the standard operating system for a hot water supply boiler operating as a water heater.

A pump delay control function with an all bronze pump is installed as standard equipment on all hot water supply boiler systems. The pump will operate only while there is a "Call for Heat" and for a timed period after the water temperature set point is satisfied to remove any residual heat from the combustion chamber.

- Lubricate pump to manufacturer's recommendations. Pump damage due to inadequate lubrication is non-warrantable.

The tank sensor must be installed in the tapping provided in the lower 25% of the storage tank to achieve proper operation. As shipped from the factory, the tank sensor is in the literature package shipped with the unit. Placing the sensor in the tapping provided on the storage tank will improve temperature response and prevent short cycles of operation.

The standard circulating pump on this hot water supply boiler is sized based on installation of a single storage tank and heater in close proximity. If the number of fittings and straight pipe exceeds the specified maximum equivalent number of straight feet for a specified diameter of pipe, non-warrantable operational problems may be experienced.

402 - 752 Models

1/4 HP, 120 VAC, 5.8 Amps

992 - 2072 Models

1/2 HP, 120 VAC, 7.4 Amps

The standard pump selection is based on the following pipe and fittings from the hot water supply boiler to the storage tank:

6 - 90° elbows 2 - ball valves
2 - unions 1 - cold water tee

Not more than 45 feet of straight pipe.

For every elbow and tee in excess of those shown above, DEDUCT 6.5 FEET from the maximum allowable straight pipe in the heater to tank circulating loop.

TABLE 8D

Water Heater Pump Applications

Model	Pipe Size	Water Hardness	Grundfos Pump	Flow Rate (GPM)	Head Loss (FT)	Temp. Rise
402	2"	5 to 15 gpg	TP44PAB	55	10	12°F
		15 to 20 gpg	UP 43-110 SF	75	10	9°F
502	2"	5 to 15 gpg	TP44PAB	55	10	15°F
		15 to 20 gpg	UP 43-110 SF	75	10	11°F
652	2"	5 to 15 gpg	TP44PAB	55	10	20°F
		15 to 20 gpg	UP 43-110 SF	75	10	15°F
752	2"	5 to 15 gpg	TP44PAB	55	10	23°F
		15 to 20 gpg	UP 43-110 SF	75	10	17°F
992	2-1/2"	5 to 15 gpg	TP24PAB	90	15	19°F
		15 to 20 gpg	TP 50-160/2B	115	15	15°F
1262	2-1/2"	5 to 15 gpg	TP24PAB	90	15	24°F
		15 to 20 gpg	TP 50-160/2B	115	15	19°F
1442	2-1/2"	5 to 15 gpg	TP24PAB	90	15	27°F
		15 to 20 gpg	TP 50-160/2B	115	15	21°F
1802	2-1/2"	5 to 15 gpg	TP24PAB	90	15	34°F
		15 to 20 gpg	TP 50-160/2B	115	15	27°F
2072	2-1/2"	5 to 15 gpg	TP24PAB	90	15	39°F
		15 to 20 gpg	TP 50-160/2B	115	15	31°F

When installing multiple hot water supply boilers and/or multiple storage tanks, the diameter of the inter-connecting pipe and all fittings must be increased. An increase in pipe diameter will decrease head loss in the system piping and ensure proper flow. Proper pipe size between the heater and storage tank **MUST** be maintained to ensure that the standard pump supplied on the hot water supply boiler will maintain desired flow.

When DHW Night Setback is enabled, the system pump output can be used to control a building circulation pump. The pump output will be on during the time Night Setback is not active and will be off when Night Setback is active. A field installed contactor must be used when controlling a circulation pump larger than 1/6 HP.

Heat exchanger

On all models, header inspection plugs in the heat exchanger can be removed for field inspection and cleaning of copper tubes. The heat exchanger may be removed from the unit.

8 Domestic water heater application *(continued)*

Thermostat adjustment procedure

1. Press the UP or DOWN key to view the set point setting.
2. Press either the UP or DOWN key to increase or decrease the displayed set point value.
3. Press the ENTER key to permanently store the new set point into the control module's memory.

Failure to press the ENTER key after changing the display value will result in the set point reverting back to its previous value after the current heat demand ends.

The control may be adjusted any time regardless of call for heat status. When pressing the UP or DOWN key to enter any new set points, the control module will immediately begin controlling based on the new set point.

Minimum water temperatures (domestic hot water use)

Domestic water temperatures:

This high efficiency hot water supply boiler should be operated at a temperature setting high enough to prevent condensing of the products of combustion on the unit's heat exchanger or in the attached venting system. Use extreme caution when storing water at elevated temperatures. A water temperature setting maintained above the dew point of the products of gas combustion should prevent condensate formation and ensure proper performance of the venting system. The manufacturer recommends the use of a properly sized thermostatic mixing valve to supply domestic hot water at temperatures less than 140°F (60°C). Storing the water at a higher temperature and thermostatically mixing the water will increase the available quantity of mixed hot water, greatly reducing the possibility of condensate formation on the heat exchanger or in the venting system and help prevent the growth of water borne bacteria.

NOTICE

Adequate care **MUST** be taken to prevent a potential scald injury when storing water at elevated temperatures for domestic use.

Inlet water temperatures below the specified minimum recommendations can excessively cool the products of combustion resulting in condensation on the heat exchanger. Condensation on the heat exchanger can cause operational problems, bad combustion, sooting, flue gas spillage and reduced service life of the related components.

CAUTION

An appliance allowed to operate at return temperatures below the specified minimum setting may experience problems with the operating controls, safety switches, obstruction of the flue gas passages on the heat exchanger, incomplete combustion, and possible flue gas spillage. Sustained operation at lower than specified water temperatures may cause hazardous conditions that may result in personal injury or non-warrantable damage to the appliance.

The maximum temperature set point that can be programmed into the control module from the Operator Interface for hot water supply boiler operation is 190°F (88°C). The control is factory pre-set at approximately 120°F (49°C). Facilities with small children or invalids may require 120°F (49°C) or a lower temperature setting to reduce risk of scald injury. Some states may require a lower temperature setting. Check with your gas supplier for local requirements governing the temperature setting. Remember, no water heating system will provide exact temperature at all times. Allow a few days of operation at this setting to determine the correct temperature setting consistent with your needs.

NOTICE

1. This hot water supply boiler when set at the lower temperature setting, is not capable of producing hot water of sufficient temperature for sanitizing purposes.

2. Higher stored water temperature increases the ability of the hot water supply boiler to supply desired quantities of hot water, however remember --

CAUTION

Hotter water increases the risk of scald injury.

8 Domestic water heater application

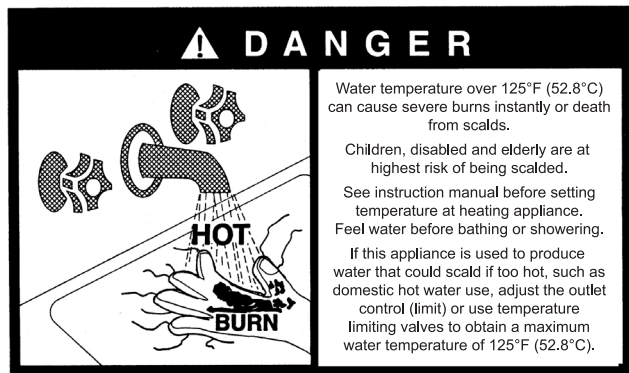

Figure 8-5_Danger Warning

Location of Cold Water Supply Piping Connections

Incorrect piping of the cold water supply to the system may result in excessive low temperature operation causing condensate formation on the primary heat exchanger and operational problems. The cold water supply piping must be installed in the discharge piping from the heater to the storage tank. This allows the cold water to be tempered in the storage tank before entering the heater. See typical installation drawings provided in this manual for correct piping (FIG.'s 8-1 thru 8-4). Higher water temperatures reduce the volume of condensate formed.

CAUTION

Setting the temperature selector to higher settings provides hotter water, which increases the risk of scald injury.

WARNING

Should overheating occur or the gas supply fail to shut off, do not turn off or disconnect the electrical supply to the pump. Instead, shut off the gas supply at a location external to the appliance.

Optional adjustable auxiliary high water temperature limit control

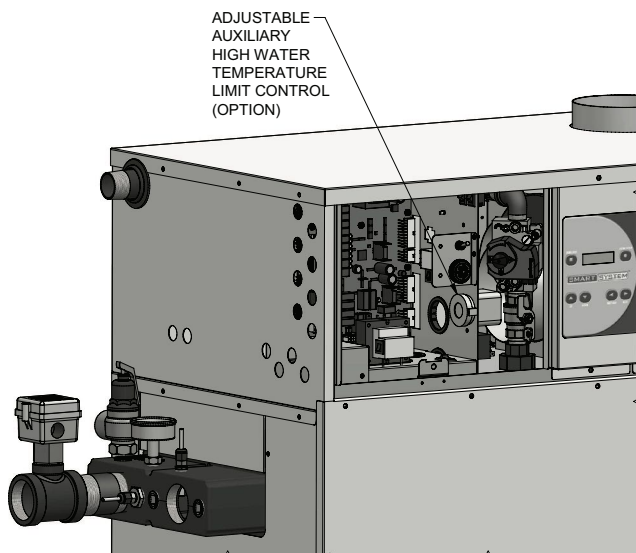

Figure 8-6_Adjustable Auxiliary High Water Temperature Limit Control

A high limit control is located on the inside of the left front panel, as shown in FIG. 8-6. The setting of this control knob limits maximum discharge water temperature. The hot water supply boiler temperature limit control is adjustable up to a maximum setting of 210°F (99°C). This hot water supply boiler also includes a fixed high water temperature limit control set to 200° (93.3°C). The RESET key on the display must be pushed whenever water temperature has exceeded the set point of the limit. The temperature of the water in the heat exchanger must drop a minimum of 15°F (8.3°C) below the setting of the high limit control before the reset function can be activated. A high limit message will be shown in the Operator Interface when water temperature exceeds the high water temperature limit control set point.

NOTICE

The high limit control will not reset until the water temperature has dropped below the set point of the high limit.

Optional relief valve

This hot water supply boiler is normally supplied with a temperature and pressure relief valve sized in accordance with applicable codes. Units may be supplied with an optional pressure only relief valve. When a hot water supply boiler is equipped with this optional relief valve and is piped to a separate storage vessel, the storage vessel must have a properly installed temperature and pressure relief valve which complies with local codes.

Thermal expansion

A relief valve that discharges periodically may be due to thermal expansion in a closed system. A hot water supply boiler installed in a closed system, such as one with a backflow preventer or check valve installed in the cold water supply, shall be provided with means to control expansion. Contact the water supplier or local plumbing inspector on how to correct this situation. Never plug or cap the relief valve discharge.

Cathodic protection

Hydrogen gas can be produced in a hot water system that has not been used for a long period of time (generally two weeks or more). Hydrogen gas is extremely flammable. To prevent the possibility of injury under these conditions, we recommend the hot water faucet be open for several minutes at the kitchen sink before you use any electrical appliance which is connected to the hot water system. If hydrogen is present, there will be an unusual sound such as air escaping through the pipe as the hot water begins to flow. There should be no smoking or open flames near the faucet at the time it is open.

9 Maintenance

Maintenance and annual startup

Table 9A_Service and Maintenance Schedules

Service technician (see the following pages for instructions)		Owner maintenance (see the Copper-fin II User's Information Manual for instructions)	
ANNUAL START-UP	General:		
	<ul style="list-style-type: none"> • Address reported problems • Inspect interior; clean and vacuum if necessary; • Check for leaks (water, gas, flue, condensate) • Examine venting system • Check system water pressure/system piping/expansion tank • Check fill water meter • Test boiler water. When test indicates, clean system water with approved system restorer following manufacturer's information. • Check control settings • Check ignitor • Check wiring and connections • Check flue gas passageways • Flame inspection (stable, uniform) • Inspect and clean the burner • Check manifold gas pressure • Perform start-up checkout and performance verification per Section 6 in the Copper-fin II Installation and Operation Manual. 	Daily	<ul style="list-style-type: none"> • Check appliance area • Check pressure/temperature gauge
	<p>If combustion or performance indicate need:</p> <ul style="list-style-type: none"> • Clean heat exchanger with a stiff bristle brush • Remove and clean burners using water. Dry before re-assembling. • Clean the blower wheel with a brush and vacuum. Do not let dirt from cleaning get pulled into the blower. 	Monthly	<ul style="list-style-type: none"> • Check vent piping • Check air piping • Check relief valve • Check building recirculation filter (if filter required) • Replace combustion air filter <p>Note: More frequent replacement may be necessary in dirty environments.</p>
		Periodically	<ul style="list-style-type: none"> • Test low water cutoff (if used) • Reset button (low water cutoff)
		Every 6 months	<ul style="list-style-type: none"> • Check appliance piping (gas and water) for leaks • Operate relief valve
	End of season months	<ul style="list-style-type: none"> • Shut appliance down (unless boiler used for domestic hot water) 	

9 Maintenance

⚠ WARNING Follow the service and maintenance procedures given throughout this manual and in component literature shipped with the appliance. Failure to perform the service and maintenance could result in damage to the appliance or system. Failure to follow the directions in this manual and component literature could result in severe personal injury, death, or substantial property damage.

⚠ WARNING The appliance should be inspected annually only by a qualified service technician. In addition, the maintenance and care of the appliance designated in Table 9A and explained on the following pages must be performed to assure maximum appliance efficiency and reliability. Failure to service and maintain the appliance and system could result in equipment failure.

⚠ WARNING Electrical shock hazard – Turn off power to the appliance before any service operation on the appliance except as noted otherwise in this instruction manual. Failure to turn off electrical power could result in electrical shock, causing severe personal injury or death.

Address reported problems

1. Inspect any problems reported by the owner and correct before proceeding.

Inspect appliance area

1. Verify that appliance area is free of any combustible materials, gasoline and other flammable vapors and liquids.

Inspect appliance interior

1. Remove the outer access panels and inspect the interior of the appliance.
2. Vacuum any sediment from inside the appliance and components. Remove any obstructions.

Check all piping for leaks

⚠ WARNING Eliminate all system or appliance leaks. Continual fresh makeup water will reduce appliance life. Minerals can build up in sections, reducing heat transfer, overheating heat exchanger, and causing heat exchanger failure. Leaking water may also cause severe property damage.

1. Inspect all water and gas piping and verify to be leak free.
2. Look for signs of leaking lines and correct any problems found.
3. Check gas line using the procedure found in *Section 3 - Gas Connections* of the Copper-fin II Installation and Operation Manual.

Flue vent system and air piping

1. Check for gastight seal at every connection, seam of air piping, and vent piping periodically inspected by a qualified service agency.

⚠ WARNING Venting system must be sealed gastight to prevent flue gas spillage and carbon monoxide emissions, which will result in severe personal injury or death.

Check water system

1. Verify all system components are correctly installed and operational.
2. Check the cold fill pressure for the system. Verify it is correct (must be a minimum of 12 PSI).
3. Watch the system pressure as the boiler heats up (during testing) to ensure pressure does not rise too high. Excessive pressure rise indicates expansion tank sizing or performance problem.
4. Inspect automatic air vents and air separators. Remove air vent caps and briefly press push valve to flush vent. Replace caps. Make sure vents do not leak. Replace any leaking vents.

Check fill water meter

1. Check fill water meter for water usage. If the amount exceeds 5% of your system volume, you could have a leak. Have the system checked for leaks and fixed by a qualified service technician.

Test boiler water

1. Test boiler water. Reference the Power-Fin Installation and Operation Manual for guidelines. When test indicates, clean system water with approved system restorer following the manufacturer's information.

Check expansion tank

1. Expansion tanks provide space for water to move in and out as the heating system water expands due to temperature increase or contracts as the water cools. Tanks may be open, closed, diaphragm or bladder type. See *Section 4 - Water Connections* of the Copper-fin II Installation and Operation Manual for suggested best location of expansion tanks and air eliminators.

9 Maintenance *(continued)*

Check relief valve

1. Inspect the relief valve and lift the lever to verify flow. Before operating any relief valve, ensure that it is piped with its discharge in a safe area to avoid severe scald potential. Read *Section 4 - Water Connections* of the Copper-fin II Installation and Operation Manual before proceeding further.

⚠ WARNING

Safety relief valves should be re-inspected **AT LEAST ONCE EVERY THREE YEARS**, by a licensed plumbing contractor or authorized inspection agency, to ensure that the product has not been affected by corrosive water conditions and to ensure that the valve and discharge line have not been altered or tampered with illegally. Certain naturally occurring conditions may corrode the valve or its components over time, rendering the valve inoperative. Such conditions are not detectable unless the valve and its components are physically removed and inspected. This inspection must only be conducted by a plumbing contractor or authorized inspection agency – not by the owner. Failure to re-inspect the boiler relief valve as directed could result in unsafe pressure buildup, which can result in severe personal injury, death, or substantial property damage.

⚠ WARNING

Following installation, the valve lever must be operated **AT LEAST ONCE A YEAR** to ensure that waterways are clear. Certain naturally occurring mineral deposits may adhere to the valve, rendering it inoperative. When manually operating the lever, water will discharge and precautions must be taken to avoid contact with hot water and to avoid water damage. Before operating lever, check to see that a discharge line is connected to this valve directing the flow of hot water from the valve to a proper place of disposal. Otherwise severe personal injury may result. If no water flows, valve is inoperative. Shut down the appliance until a new relief valve has been installed.

2. After following the above warning directions, if the relief valve weeps or will not seat properly, replace the relief valve. Ensure that the reason for relief valve weeping is the valve and not over-pressurization of the system due to expansion tank waterlogging or undersizing.

Inspect/replace hot surface igniter

This unit uses a proven SMART SYSTEM control module and a hot surface igniter. The SMART SYSTEM control module is not repairable. Any modification or repairs will invalidate the warranty.

⚠ WARNING

Do not attempt to repair a faulty hot surface igniter or control module. Any modification or repairs may create hazardous conditions that result in property damage, personal injury, fire, explosion and/or toxic gases.

A faulty hot surface igniter or control module must be replaced with an identical part. A specification igniter and control module for this specific unit is available from your local distributor. **Do not use general purpose field replacement control modules or igniters.**

Ignition system checkout

1. Turn off gas supply to unit.
2. Turn electric power on.
3. Adjust the set point on the temperature control to a setting above water temperature or to the highest safe setting.
4. The igniter will cycle on trial for ignition.
5. The control module will lock out and turn the alarm light on.
6. Adjust the Set Point Differential and High-Fire Offset to the desired settings.
7. Turn on gas supply.
8. Press the RESET button at the electronic display panel to reset the control module.
9. If ignition system fails to operate properly, repair work must be performed by a qualified service person or installer.

Check all wiring

1. Inspect all wiring, making sure wires are in good condition and securely attached.

Check control settings

1. Set the SMART SYSTEM control module display to Parameter Mode and check all settings. See Section 1 of this manual. Adjust settings if necessary. See Section 1 of this manual for adjustment procedures.
2. Check settings of external limit controls (if any) and adjust if necessary.

9 Maintenance

Perform start-up and checks

1. Start appliance and perform checks and tests specified in *Section 7 - Start-up* of the Copper-fin II Installation and Operation Manual.
2. Verify cold fill pressure is correct and that operating pressure does not go too high.

Check burner flame

Visually check main burner flames at each start-up after long shutdown periods or at least every six months. A burner viewport is located on the burner mounting flange.

⚠ WARNING The area around the burner viewport is hot and direct contact could result in burns.

Figure 9-2_Flame Pattern Illustration

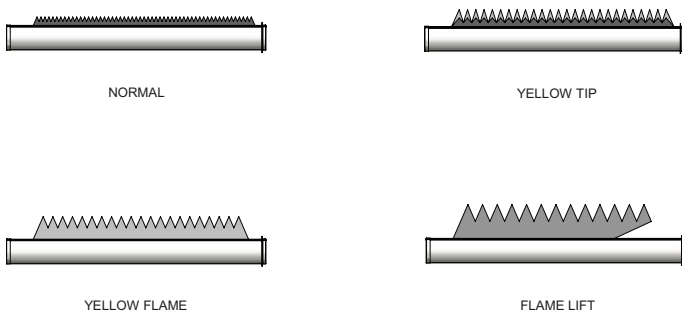

Normal Flame: A normal flame at 100% of burner input is blue, with slight yellow tips, a well defined flame and no flame lifting.

Yellow Tip: Yellow tipping can be caused by blockage or partial obstruction of air flow to the burner.

Yellow Flames: Yellow flames can be caused by blockage of primary air flow to the burner or excessive gas input. This condition **MUST** be corrected immediately.

Lifting Flames: Lifting flames can be caused by over firing the burner, excessive primary air or high draft.

If improper flame is observed, examine the venting system, ensure proper gas supply and adequate supply of combustion and ventilation air.

Check flue gas passageways

Any sign of soot around the inner jacket, outer jacket, flue pipe connections, burner or in the areas between the fins on the copper heat exchanger indicates a need for cleaning. The following cleaning procedure must only be performed by a qualified serviceman or installer. Proper service is required to maintain safe operation. Properly installed and adjusted units seldom need flue cleaning.

NOTICE

All gaskets/sealants on disassembled components or jacket panels must be replaced with new gaskets/sealants on reassembly. Gasket and sealant kits are available from your distributor.

CAUTION

When a Category IV vent system is disconnected for any reason, the flue must be reassembled and resealed according to the vent manufacturer's instructions.

Inspect and clean burner

1. Turn off main power to unit.
2. Turn off main manual gas shutoff to unit.
3. Remove the front outer jacket panels.
4. Disconnect manifold from gas train using union(s) just below each gas valve(s).
5. Remove mounting screws from manifold mounting brackets. Pull the manifold/orifice assembly away from burners. Repeat for each manifold assembly.
6. Remove two mounting screws from burner and slide burner out toward front of unit. Use caution to prevent damage to burners, refractory, hot surface igniter or wiring.
7. Remove soot from burners with a stiff bristle brush.

Dirt may be removed from burner ports by rinsing the burner thoroughly with water. Drain and dry burners before re-installing. Damaged burners must be replaced.

When installed in a dusty and dirty location, the burners may require cleaning on a 3 to 6 month schedule or as needed, based on severity of contamination. Contaminants can be drawn in with the combustion air. Non combustible particulate matter such as dust, dirt, concrete dust or dry wall dust can block burner ports and cause non-warrantable failure. The standard inlet air filter will help eliminate dust and dirt from entering the unit. Use extreme care when operating a unit for temporary heat during new construction. The burners could require a thorough cleaning before the unit is placed in service.

9 Maintenance *(continued)*

Inspect and clean the heat exchanger

1. While burners are removed, check the heat exchanger surface for sooting. If present, heat exchanger must be cleaned and problem corrected. Proceed as follows.
2. Remove gas manifold(s)/orifice assemblies as described in steps 1 through 5 in Burner Removal and Cleaning, page 76.
3. Disconnect wiring from the hot surface igniter and hose from the burner pressure tap.
4. Remove inner jacket panel mounting screws and slide door assembly out toward front of the unit. Use caution to prevent damage to the refractory and hot surface igniter.
5. Check “V” baffles and frame runners along front and back edges of heat exchanger. Remove and clean if necessary.
6. Remove soot from heat exchanger with a stiff bristle brush. Use a vacuum to remove loose soot from surfaces and inner chamber.
7. The heat exchanger can be removed by sliding towards the front of the unit. Once the heat exchanger is removed from the unit, a garden hose can be used to wash the tubes to ensure that all soot is removed from the heat exchanger surfaces. Note: Do not wet the unit’s refractory.
8. Ensure that all burner ports are cleaned to remove any soot. See Burner Removal and Cleaning, page 76.
9. Carefully reinstall the heat exchanger, “V” baffles, and frame runners if removed from the unit. Note: Make sure frame runners seal securely where they contact the front and rear compartment refractory.
10. Carefully reinstall inner jacket panels, burners, manifolds, wires and hoses. Use new gasket material to ensure a proper air seal.
11. Reassemble all gas and water piping. Test for gas leaks.

NOTICE

Upon completion of any testing on the gas system, leak test all gas connections with a soap and water solution while main burners are operating. Do not spray soap and water solution on the SMART SYSTEM control module housing. The use of an excessive amount of soap and water solution can damage the control. Immediately repair any leak found in the gas train or related components. Do not operate an appliance with a leak in the gas train, valves, or related piping.

12. Reassemble outer jacket panels.
13. Cycle unit and check for proper operation.

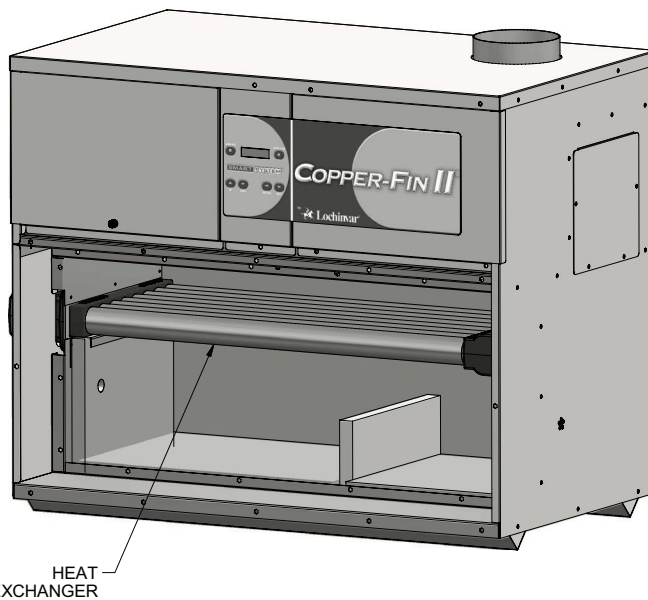

Figure 9-3 Location of the Heat Exchanger Inside Jacket

Review with owner

1. Review the Copper-fin II User’s Information Manual with the owner.
2. Emphasize the need to perform the maintenance schedule specified in the Copper-fin II User’s Information Manual (and in this manual as well).
3. Remind the owner of the need to call a licensed contractor should the appliance or system exhibit any unusual behavior.
4. Remind the owner to follow the proper shutdown procedure and to schedule an annual start-up at the beginning of the next heating season.

Oiled bearing circulators

Inspect the pump every six (6) months and oil as necessary. Use SAE 30 non-detergent oil or lubricant specified by the pump manufacturer.

10 Connection diagram

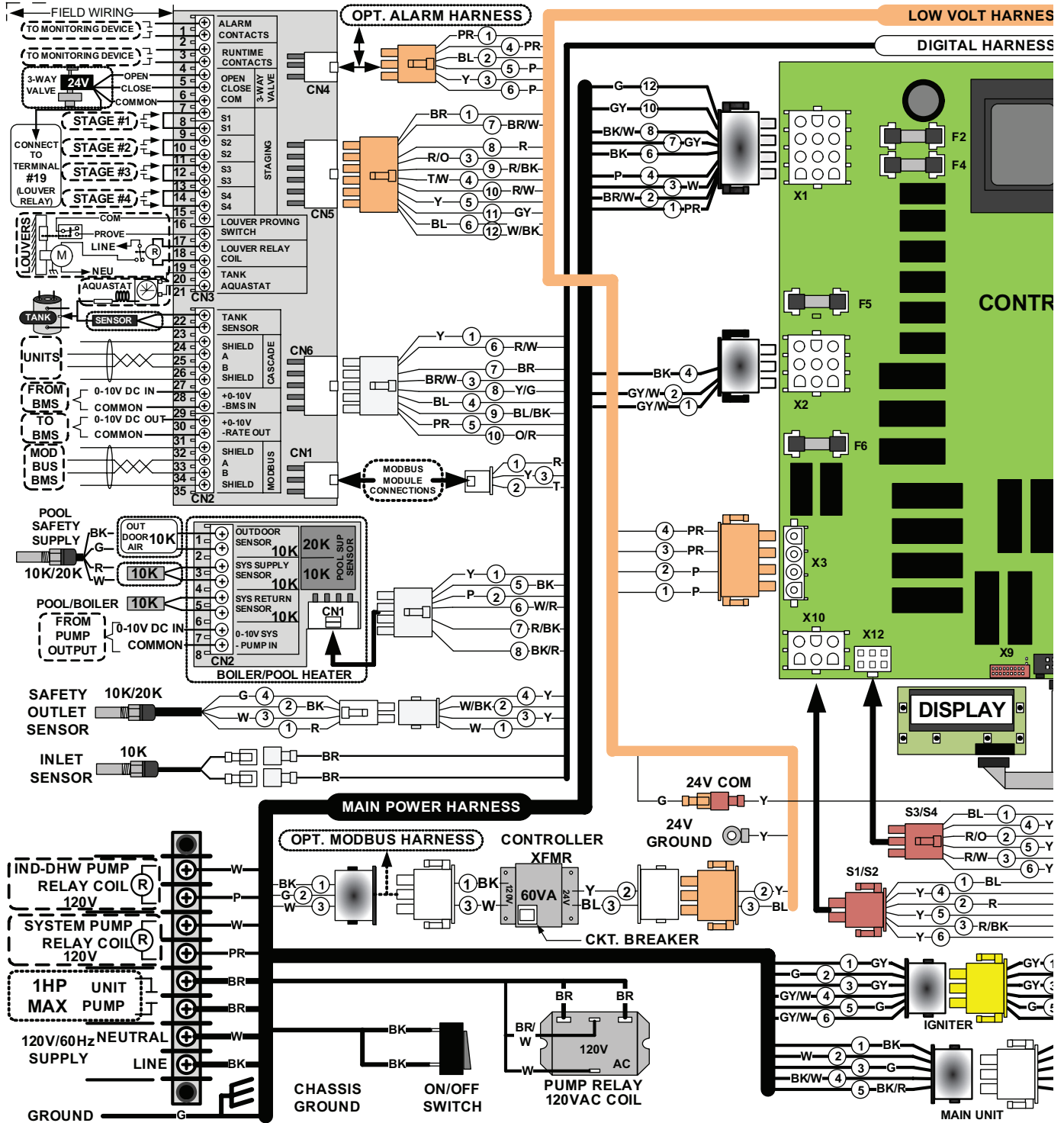

10 Connection diagram (continued)

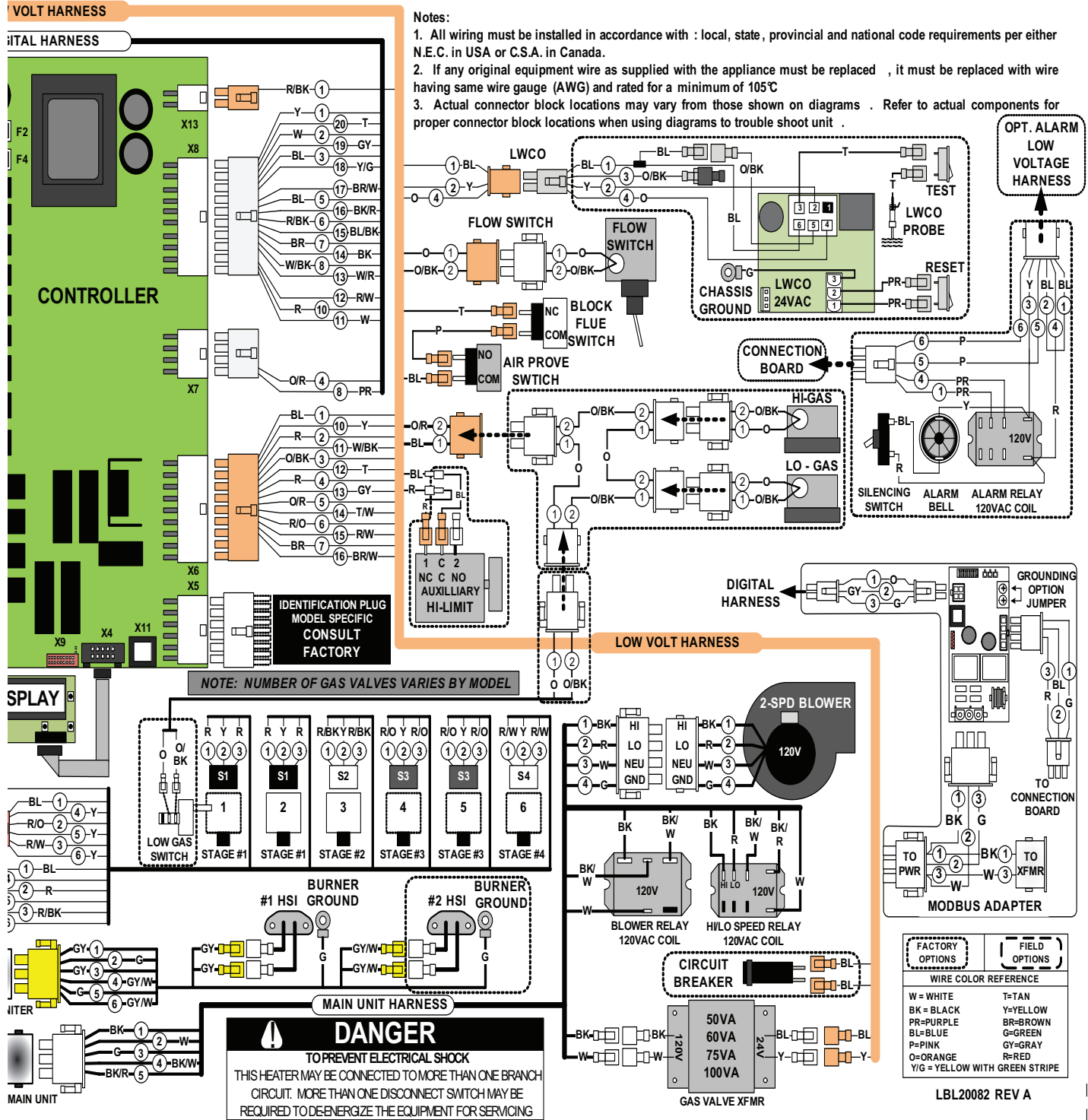

11 Ladder diagram

WHERE POSSIBLE, SWITCHES ARE SHOWN WITHOUT UTILITIES (GAS, WATER OR ELECTRICITY) CONNECTED TO THE UNIT. AS SUCH, ACTUAL SWITCH STATES MAY VARY FROM THOSE SHOWN ON DIAGRAMS DEPENDING UPON WHETHER UTILITIES ARE CONNECTED OR A FAULT CONDITION IS PRESENT. SEE WIRING DIAGRAM FOR ADDITIONAL NOTES.

⚠ WARNING
DISCONNECT POWER
BEFORE SERVICING

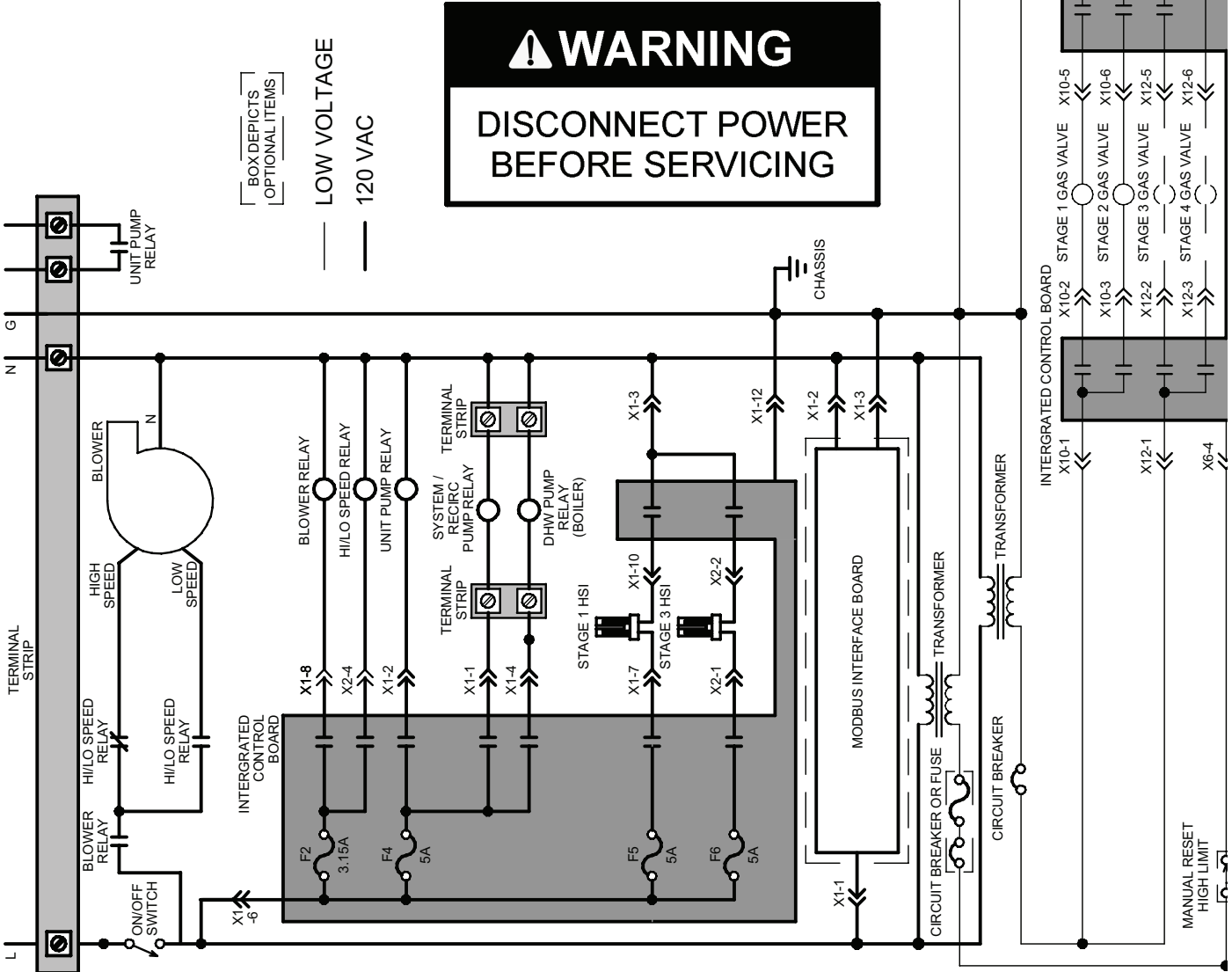

11 Ladder diagram (continued)

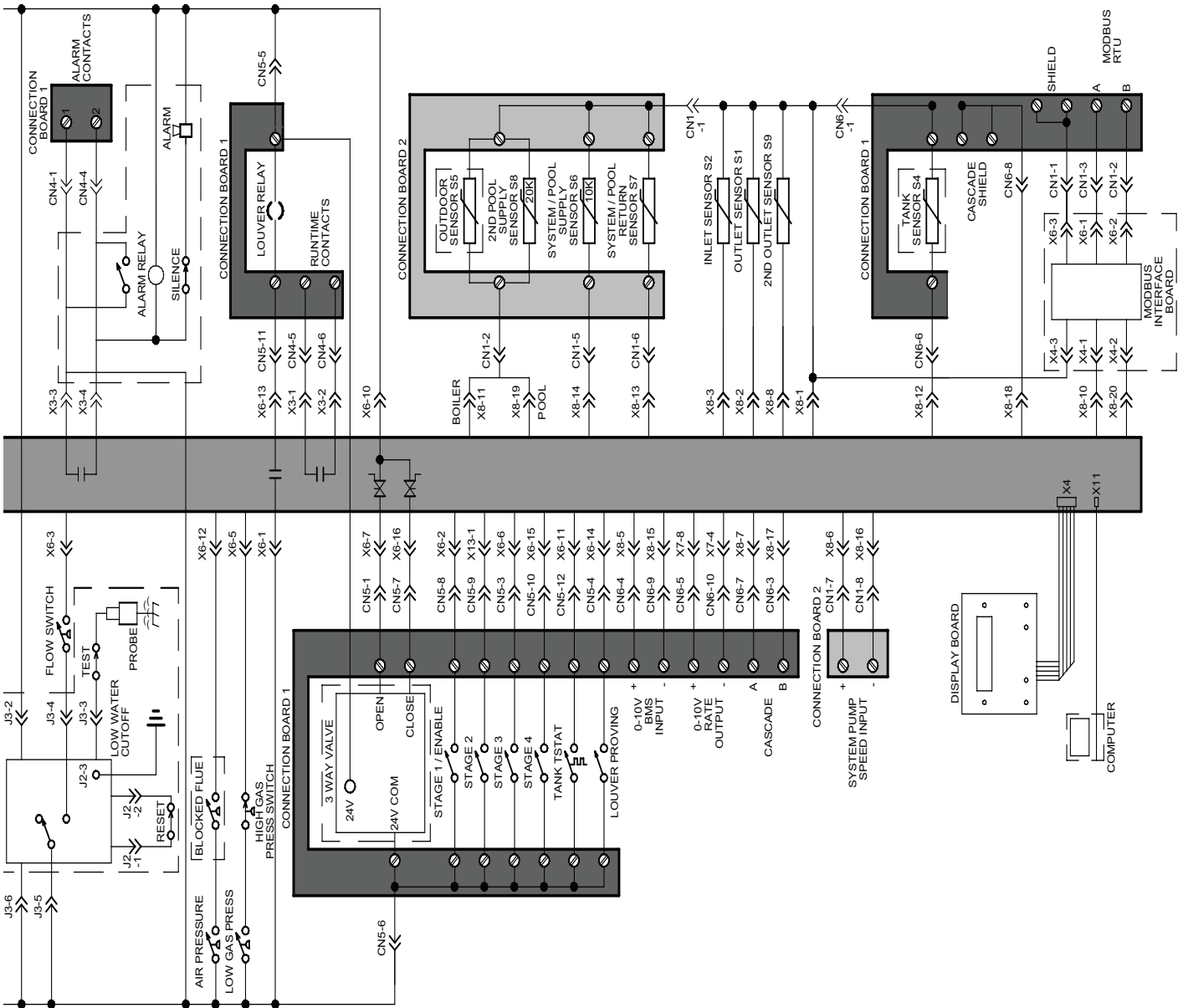

LBL20083 REV B

Notes

Notes

Revision Notes: Revision A (ECO #C08226) initial release.

Revision B (ECO C09691) reflects the update of AHRI and ASME logos on page 8.

Revision C (ECO C11124) reflects the modification of ignition timing information on pages 55 and 58 as well as the addition of VAL30002 in Table 4A on page 36.

Revision D (ECO C11706) reflects the update of heat exchanger information on page 68 and system return sensor information on page 45.

Revision E (ECO C12972) reflects the addition of the CSA Low Lead Content logo.

Revision F (ECO C16918) reflects the update of the ratings tables on page 8 as well as changes made to Table 3D - Gas Piping Chart on page 33 (R6621).

Revision G (CN# 500000349) reflects the update of FIG. 8-4 on page 67 to remove stray piping in image.

Revision H (PCP #3000001144 / CN #500002277) reflects the addition of edits made to Boiler Water on page 4, along with the addition of the Important and Notice items under Heating Boiler Installations on page 35, as well as edits to section 6 (Start-up) on pages 47 and 48. SAP part numbers have been updated.

Revision J (PCP# 3000002766 / CN# 500003005) reflects a correction to images 8-1 through 8-4 on pages 66 through 69.

Revision K (PCP# 3000006580 / CN# 500006678) reflects a change from all instances of the word "water heater" to "hot water supply boiler," and references to ANSI Z21.13.

Revision L (PCP #3000021634 / CN #500011858) reflects changes made to water chemistry information on pages 4, 35, 37, 39-42, 47-48, 64-69, and 73-74.

Revision M (PCP #3000030852 / CN #500020656) reflects an update to all piping diagrams, the addition of the notice on page 65, an update to Vent E on page 14, and Table 9A.

Revision N (PCP #3000033785 / CN #500022613) reflects the input rates and output rates are revised to match AHRI rounding and comply with Energy Star turndown rate requirements.