



PRODUCT LITERATURE

Lennox Industries Inc.
Dallas, Texas

INSTALLATION INSTRUCTIONS

GSB8-E GAS-FIRED STEAM BOILER



RETAIN THESE INSTRUCTIONS FOR FUTURE REFERENCE

***These instructions must be
affixed on or adjacent to the
boiler.***

GAS-FIRED HOT WATER BOILERS

These Gas-Fired Water Boilers are low pressure, sectional cast iron boilers Design Certified by CSA (Canadian Standards Association) for use with Natural and Propane Gases. They are constructed and hydrostatically tested for a maximum working pressure of 50 psi (pounds per square inch) in accordance with A.S.M.E. (American Society of Mechanical Engineers) Boiler and Pressure Vessel Code Section IV: Rules for Construction of Heating Boilers.

WARNING

Improper installation, adjustment, alteration, service, or maintenance can cause injury or property damage. Refer to this manual. For assistance or additional information consult a qualified installer, service agency, or the gas supplier.



DIMENSIONS

Figure 1 - Dimensions

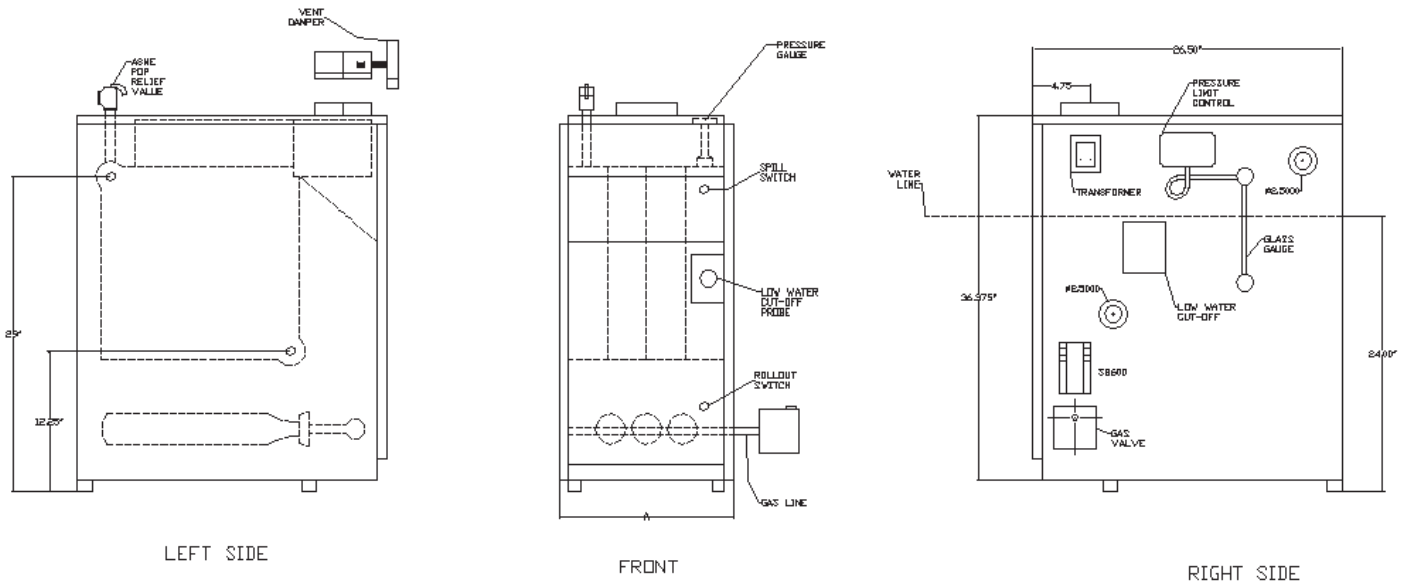

BOILER MODEL NUMBER ⁽¹⁾	Dimensions (Inches)	
	Flue Diameter	"A" Width
GSB8-075E	5	11 1/4
GSB8-112E	6	14 1/2
GSB8-150E	6	17 3/4
GSB8-187E	7	21
GSB8-225E	7	24 1/4
GSB8-262E	7	27 1/2
GSB8-299E	7	30 3/4

Add 5 1/2" to height for Vent Damper
⁽¹⁾ Add model number suffix 'P' for Propane Gas.

RATINGS AND CAPACITY



Table 1 - Ratings and Capacities

BOILER MODEL NUMBER	No. of Sec.	† Natural Gas					
		Fuel Type	Input *MBTUH	Heating Capacity *MBTUH	AFUE(%)	Net AHRI Rating *Mbh	Net AHRI Rating Sq. Ft.
(1) GSB8-075E	3	Natural Gas	75	62	82.7	47	196
		Propane	70	58	82.7	44	183
(1) GSB8-112E	4	Natural Gas	112	91	82.0	68	283
		Propane	105	85	80.4	64	267
(1) GSB8-150E	5	Natural Gas	150	122	82.0	92	383
		Propane	140	114	80.6	86	358
(1) GSB8-187E	6	Natural Gas	187	153	82.0	115	479
		Propane	175	143	80.9	107	446
(1) GSB8-225E	7	Natural Gas	225	183	82.0	137	571
		Propane	210	171	81.1	128	533
(1) GSB8-262E	8	Natural Gas	262	214	82.0	161	671
		Propane	245	200	81.3	150	625
(1) GSB8-299E	9	Natural Gas	299	245	82.0	184	767
		Propane	280	229	81.5	172	717

* MBH = 1,000 Btuh. Btuh = British Thermal Unit Per Hour.

† For altitudes above 2,000 ft. reduce input rate 4% for each 1,000 ft. above sea level.

Heating Capacity is based on DOE (Department of Energy) test procedure.

(1) Add model number suffix 'P' for Propane Gas.

Net AHRI steam Ratings shown are based on a piping and pickup allowance of 1.333.

Base selection of boiler size on "Net AHRI Rating" being equal to or greater than installed radiation in square feet. Consult manufacturer before selecting a boiler for installations having unusual piping and pickup requirements, such as intermittent system operation, exhaust piping systems, etc.

TABLE OF CONTENTS

Dimensions.....	2
Ratings and Capacity	3
Safety Symbols	5
Locating the Boiler.....	6
System Piping	7
Installation - System Piping	10
Fresh Air for Combustion	11
Chimney and Vent Pipe Connection	12
Vent Damper Operation	14
Gas Supply Piping.....	15
Electrical Wiring	16
Operating Instructions.....	17
Operating Your Boiler	18
Checking and Adjusting	19
Start-up Cleaning	21
General Maintenance	22
Service Hints	23
Wiring Diagrams.....	24
Wiring diagrams	25
Controls and Accessories	26
Repair Parts	27

Introduction

Boiler is designed for use in closed heating systems where all steam is returned as condensate and make-up water is minimal. Boiler is not designed for or intended for use in open systems using 100% make-up water.

Prior to Installation

- Verify correct boiler for type of gas being used natural or propane. See Rating Plate.
- Verify boiler size and dimensions. See Figure 1 page 2.
- Verify ratings and capacity data for natural gas. See Table 1 page 3.

Installation Requirements

- Supply boiler with correct gas (natural or propane), fresh air for combustion, and suitable electrical supply.
- Connect boiler to adequate venting and piping systems.
- Provide boiler with properly located and adjusted thermostat.

Installation of boiler in building under construction, use precaution to insure clean combustion air supply during construction process. Airborne particulate from construction materials can clog burner ports and cause incomplete combustion and sooting.

Complete all steps for safe and proper heating system operation.

KEEP THIS MANUAL NEAR BOILER
RETAIN FOR FUTURE REFERENCE

GAS FIRED STEAM BOILERS

Information and specifications outlined in this manual in effect at the time of printing of this manual. Manufacturer reserves the right to discontinue, change specifications or system design at any time without notice and without incurring any obligation, whatsoever.

SAFETY SYMBOLS

General

Boiler and venting installation shall be completed by qualified agency.

WARNING

Fire, explosion, asphyxiation and electrical shock hazard. Improper installation could result in death or serious injury. Read this manual and understand all requirements before beginning installation.

Become familiar with symbols identifying potential hazards.



This is the safety alert symbol. Symbol alerts you to potential personal injury hazards. Obey all safety messages following this symbol to avoid possible injury or death.

DANGER

Indicates a hazardous situation which, if not avoided, WILL result in death or serious injury.

WARNING

Indicates a hazardous situation which, if not avoided, could result in death or serious injury.

CAUTION

Indicates a hazardous situation which, if not avoided, may result in minor or moderate injury.

NOTICE

Used to address practices not related to personal injury.

Installation shall conform to requirements of authority having jurisdiction or in absence of such requirements to the National Fuel Gas Code, ANSI Z223.1/NFPA 54.

Where required by authority having jurisdiction, installation shall conform to Standard for Controls and Safety Devices for Automatically Fired Boilers, ANSI/ASME CSD-1. Controls can be added to make this boiler CSD-1 compliant. Check with your local codes for requirements.

Requirements for Commonwealth of Massachusetts: Boiler installation must conform to Commonwealth of Massachusetts code 248 CMR which includes but is not limited to installation by licensed plumber or gas fitter.

WARNING

Installing or venting a boiler or any other gas appliance with improper methods or materials could result in death or serious injury due to fire or to asphyxiation from poisonous gases such as carbon monoxide which is odorless and invisible.

WARNING

Fire, explosion, asphyxiation hazard. Keep boiler area clear and free from combustible materials, gasoline and other flammable vapors and liquids.

Modification, substitution or elimination of factory equipped, supplied or specified components could result in death or serious injury.

Locating the Boiler

1. Select level location as centralized with piping system, and as near chimney as possible.
2. Place crated boiler at selected location. Remove all crate material. Please recycle responsibly.

⚠ WARNING

Fire hazard. Do not install boiler on combustible flooring or carpeting. Failure to follow these instructions could result in death or serious injury.

3. **Do not install boiler on carpeting. For installation on non-combustible floors only.** For installation on combustible flooring, special base must be used. See Repair Parts page 27.
4. Use metal shims under boiler base legs for final leveling if needed.
5. Install boiler in location that permits satisfactory combustion of gas, proper venting, and maintenance of ambient temperature at safe limits under normal conditions of use. Boiler location should not interfere with proper circulation of air. Introduce outside air if normal infiltration does not provide necessary air. "Fresh Air for Combustion" on page 11.
6. Notify owner to keep air passages free of obstruction. Ventilating and combustion air must enter boiler room without restrictions.
7. Install boiler so automatic gas ignition system components are protected from water (dripping, spraying, rain, etc.) during appliance operation and service.

Table 2 - Minimum Clearance Dimensions	
Top	6"
Rear	6"
Control Side	7"
Opposite Side	6"
Front	Alcove
Flue/Vent Connector	6"

Draft Hood Installation

⚠ WARNING

Asphyxiation, carbon monoxide hazard. Failure to follow these instructions could result in improper combustion and possible leakage of combustion products into the living space.

Follow directions given in Figure 8. Attach draft diverter, and blocked vent switch. Mount vent damper. See "Connecting Vent Damper and Vent Connector" page 12. See Wiring Diagrams page 25.

⚠ WARNING

Burn or Scald Hazard. Discharge line shall be installed to relief valve outlet connection to avoid burns, scalding, or water damage due to discharge of steam and/or hot water during operation.

Discharge line shall:

- Connect to safety valve outlet. Piped down to safe point of disposal. Check local codes for maximum distance from floor or allowable safe point of discharge.
- Pipe size be of equal to or greater than of safety valve outlet over entire length of discharge line.
- Have no intervening shutoff valve between safety valve and discharge to atmosphere. Do not plug or place any obstruction in discharge line.
- Terminate freely to atmosphere where any discharge will be clearly visible and at no risk of freezing.
- Allow complete drainage of valve and discharge line.
- Install safety valve with spindle in vertical position.
- Do not install shutoff valve between boiler and safety valve.
- Support safety valve discharge piping.
- Be short and straight as possible.
- Terminate with plain end, not threaded.
- Constructed of material suitable for exposure to temperatures of 375° F (191°C); or greater.

Refer to local codes and appropriate ASME Boiler and Pressure Vessel Code for additional installation requirements.

Figure 3 - Safety Valve

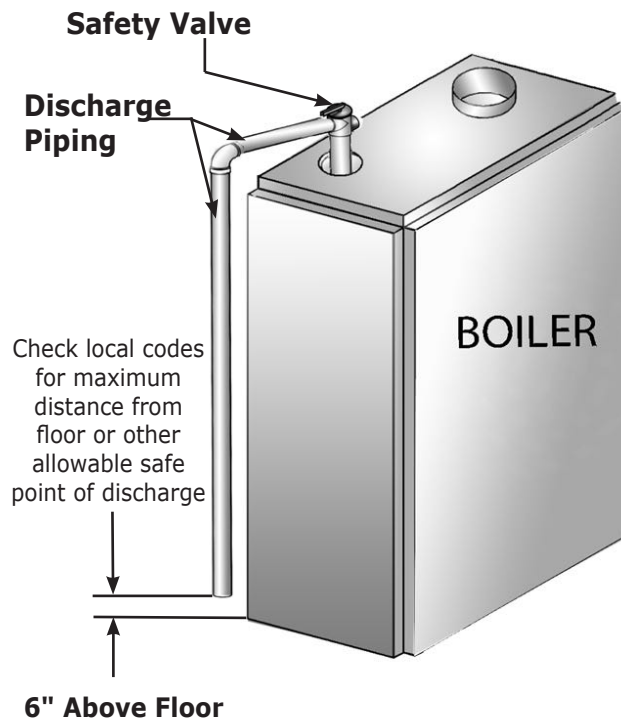

SYSTEM PIPING

Consider near boiler piping as part of the boiler for proper water level control and to produce dry steam.

Correct near boiler piping is crucial to proper operation of boiler and heating system.

Follow these recommendations carefully.

1. Place boiler in selected location as near chimney as possible.
2. Install safety valve. Figure 3 and Warning on Page 7.
 - Install union, if used, close to safety valve outlet.
 - Install elbows close to safety valve outlet and downstream of union (if used).
3. Boiler is equipped with two 2½" supply connections and two 2½" return connections, one each on both left and right sides of boiler. Plug unused connections with furnished 2½" plug (furnished).
4. When using both supply tapplings to pipe system as shown in Figure 5, Page 10.
 - Fit headers with header offsets, swing joints, or equip with expansion joints, so thermal expansion and contraction of header does not damage boiler. Do not weld headers.
 - Place system takeoffs from header between equalizer and riser to header nearest equalizer. System takeoffs must never be between two risers. If steam main goes in two directions, place two takeoffs from header, one for each main.
5. System takeoffs from the header must never be bullheaded. If the steam main goes in two directions, there must be two takeoffs from the header, one for each main.
6. All boilers in gravity return systems **must** be equipped with a Hartford Loop as shown in Figure 5.
7. When piping the vertical risers from the boiler to the header, the bottom of the header must be a minimum of 24 inches above the water level line on the right side of the boiler.
8. Steam riser(s) and header shall be 2½" pipe size.
9. Equalizer line shall be minimum 1½" pipe size.
10. The near boiler piping shall include a 2½" tee with a plug located on the supply line as shown for skimming (i.e. surface blowdown).
11. The near boiler piping shall include a 1-1/2 ball valve in the return piping as shown for bottom blowdown and draining.
12. For gravity return systems, the bottom of the lowest steam carrying pipe, be it a dry return, or the end of the steam main, must be at least 28" above the normal water level line on the right side of the boiler. This is known as "Dimension A."

13. For pumped return systems, follow the condensate pump or boiler feed pump manufacturer's instructions for proper installation and hookup.

14. In connecting the cold water supply to the water inlet valve, make sure that a clean water supply is available. When the water supply is from a well or pump, a sand strainer should be installed at the pump.

For Use With Cooling Units

Install boiler, when used in connection with refrigeration system, so chilled medium is piped in parallel with boiler with appropriate valves to prevent chilled medium from entering the boiler. See Figure 6.

SYSTEM PIPING

Figure 4 - Recommended Near Boiler Piping Using One Supply Tapping

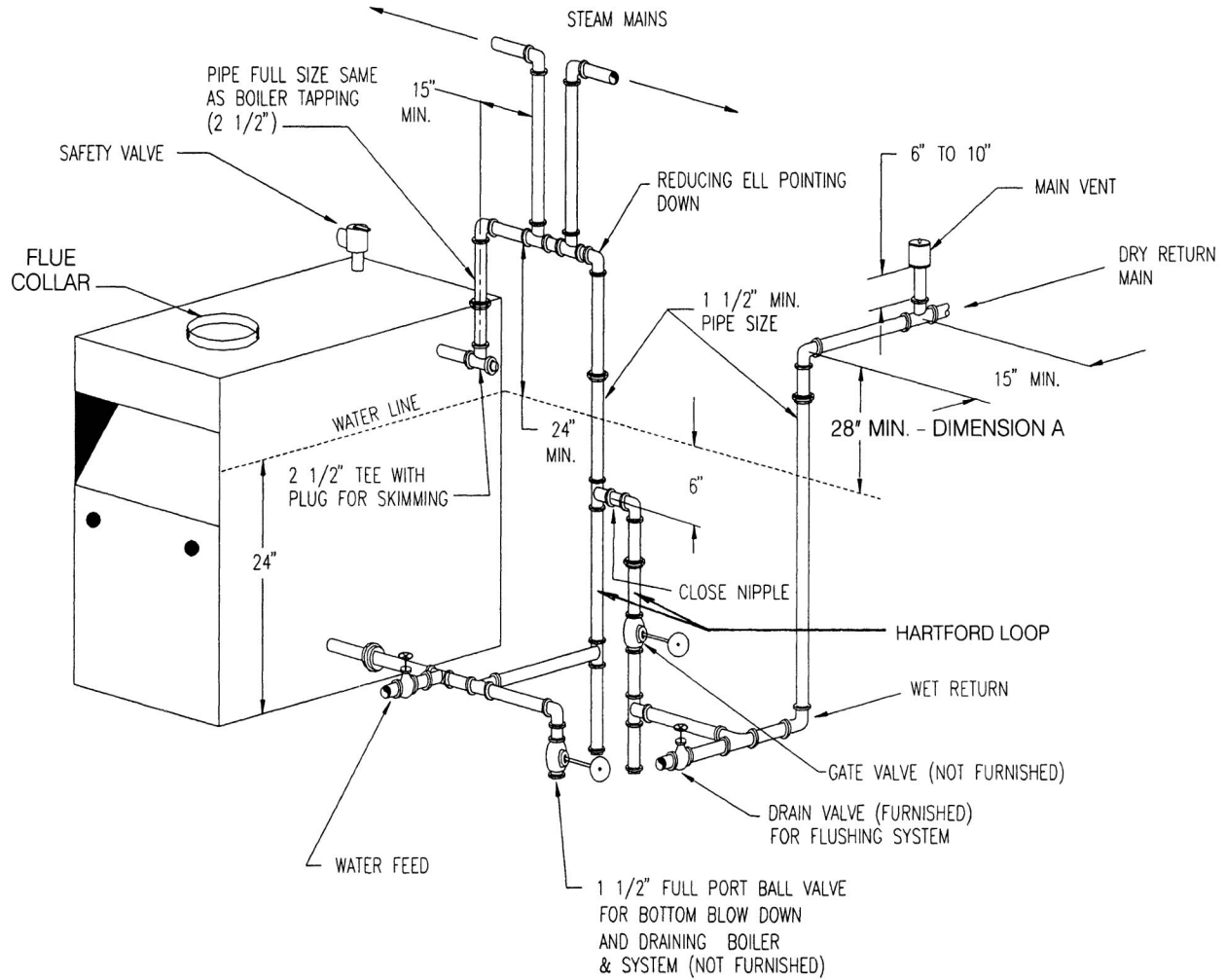

Figure 5 - Recommended Near Boiler Piping Using Two Supply Tappings

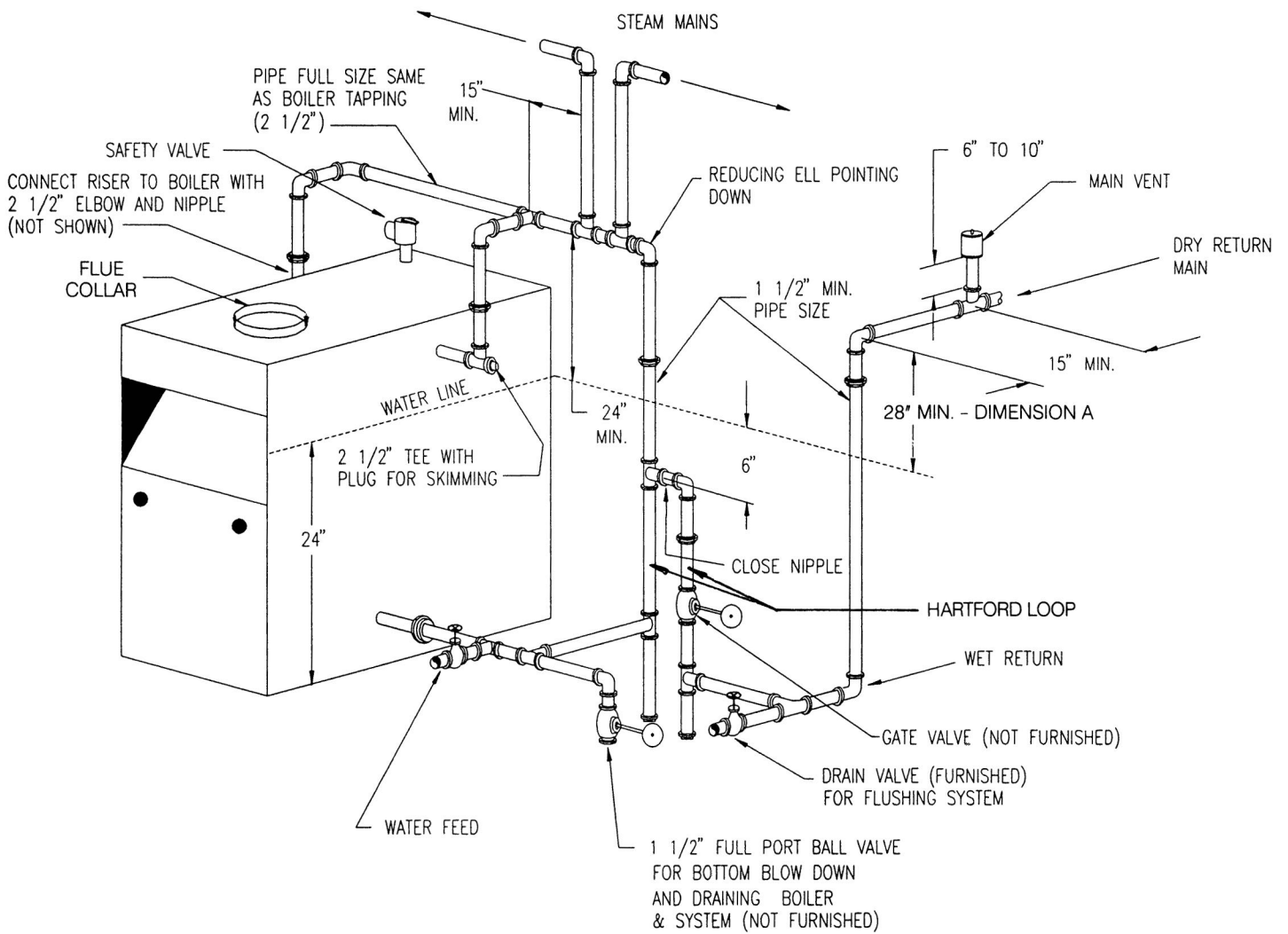
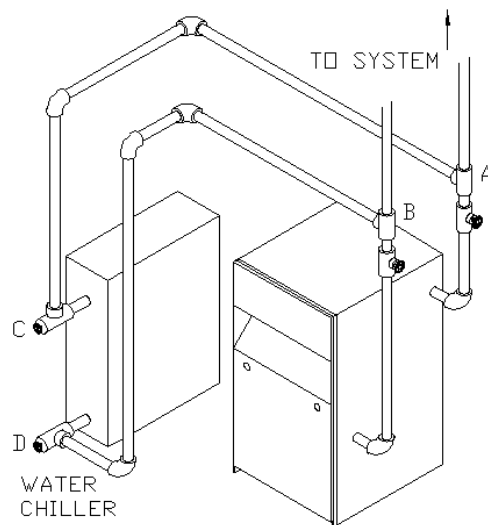

Figure 6 - Chilled Water Piping



VALVES A & B OPEN FOR HEATING; CLOSE FOR COOLING

VALVES C & D CLOSE FOR HEATING; OPEN FOR COOLING

FRESH AIR FOR COMBUSTION

WARNING

Air openings to combustion area must not be obstructed. Follow instructions below, to maintain adequate combustion air

Provide combustion air and ventilation air in accordance with the section "Air for Combustion and Ventilation," of the National Fuel Gas Code, ANSI Z223.1 / NFPA 54, or applicable provisions of local building codes.

Provide make-up air where exhaust fans, clothes dryers, and kitchen ventilation equipment interfere with proper operation.

National Fuel Gas Code recognizes several methods of obtaining adequate ventilation and combustion air. Requirements of the authority having jurisdiction may override these methods.

- Engineered Installations. Must be approved by authority having jurisdiction.
- Mechanical Air Supply. Provide minimum of 0.35 cfm per Mbh for all appliances located within space. Additional requirements where exhaust fans installed. Interlock each appliance to mechanical air supply system to prevent main burner operation when mechanical air supply system not operating.
- All Indoor Air. Calculate minimum volume for all appliances in space. Use a different method if minimum volume not available.
 - A. Standard Method. See Table 3 for space with natural gas boiler only. Use equation for multiple appliances and/or propane.
Room Volume is greater than 50 cubic feet multiplied by Total Input [Mbh]

- B. Known Air Infiltration Rate. See Table 3 for space with boiler only. Use equation for multiple appliances. Do not use an air infiltration rate air changes per hour (ACH) greater than 0.60.
Room volume is greater than 21 cubic feet divided by ACH (air changes per hour) x Total Input [Mbh]
- C. Refer to National Fuel Gas Code for opening requirements between connected indoor spaces.
- All Outdoor Air. Provide permanent opening(s) communicating directly or by ducts with outdoors.
 - A. Two Permanent Opening Method. Provide opening commencing within 12 inches of top and second opening commencing within 12 inches of bottom of enclosure.
 - Direct communication with outdoors or communicating through vertical ducts. Provide minimum free area of 1 in² per 4 Mbh of total input rating of all appliances in enclosure.
 - Communicating through horizontal ducts. Provide minimum free area of 1 in² per 2 Mbh of total input rating of all appliances in enclosure.
 - B. One Permanent Opening Method. Provide opening commencing within 12 inches of top of enclosure. Provide minimum clearance of 1 inch on sides/back and 6 inches on front of boiler (does not supersede clearance to combustible materials).
 - C. Refer to National Fuel Gas Code for additional requirements for louvers, grilles, screens and air ducts.
- Combination Indoor and Outdoor Air. Refer to National Fuel Gas Code for application information.

Table 3 - Minimum Room Volume, Indoor Air Only*

Input Mbh	Standard Method	Known Air Infiltration Rate Method (Air Changes Per Hour)					
		0.1	0.2	0.3	0.4	0.5	0.6
75	3750	15750	7875	5250	3938	3150	2625
112.5	5625	23625	11813	7875	5906	4725	3938
150	7500	31500	15750	10500	7875	6300	5250
187	9350	39270	19635	13090	9818	7854	6545
225	11250	47250	23625	15750	11813	9450	7875
262.5	13125	55125	27563	18375	13781	11025	9188
299	14950	62790	31395	20930	15698	12558	10465

* Table values based on boiler only. Add volume for any additional appliances.

WARNING

Installing or venting a boiler or any other gas appliance with improper methods or materials could result in death or serious injury due to fire or to asphyxiation from poisonous gases such as carbon monoxide which is odorless and invisible.

Boiler and venting installations shall be performed in accordance with "Venting of Equipment", of the National Fuel Gas Code, ANSI Z223.1/NFPA 54, or applicable provisions of the local building codes.

Chimney Inspection

Chimney must be clean, sized correctly, properly constructed and in good condition.

Installation must conform to requirements of the authority having jurisdiction or, in absence of such requirements, to the National Fuel Gas Code, ANSI Z223.1/NFPA 54. See Figure 7, page 13.

Connecting The Vent Damper And Vent Connector

Refer to Figure 1 for the size and location of the vent (flue opening). Use a 28 gauge (minimum) galvanized pipe to connect to the chimney.

Furnished vent damper blade has 1/2 square inch hole (approximately 3/4" diameter). Boilers equipped with intermittent ignition, plug hole using plug supplied with vent damper.

1. Position furnished vent damper on top of flue outlet collar. Fasten damper securely to flue outlet collar with sheet metal screws. Make sure damper blade has clearance to operate inside of diverter. Do not modify draft diverter or vent damper

As An Option

Damper may be installed in any horizontal or vertical position, closer to flue outlet collar preferred. See Figures 7, 8 and 9.

2. Install vent damper to service single boiler only for which it is intended. Damper position indicator shall be in visible location following installation. Locate damper so it is accessible for servicing.
3. Damper must be in open position when appliance main burners are operating.
4. Boiler is equipped with factory wired harness that plugs into vent damper. Connect thermostat to black wires marked 24 volt thermostat on boiler.
5. Vent pipe must be same size as flue outlet collar.
6. Slope pipe up from boiler to chimney not less than 1/4" per foot.
7. Run pipe as directly as possible with as few elbows as possible.
8. Do not connect to fireplace flue.

9. End of vent pipe must be flush with inside face of chimney flue. Use sealed-in thimble for chimney connection.
10. Horizontal run should not be longer than 3/4 the chimney height (HT) Figure 7, page 13.

Vent Pipe

- Fasten sections of vent pipe with 3 sheet metal screws at each joint to make piping rigid.
- Support horizontal portions of vent system to prevent sagging.
- Use stovepipe wires or metal strapping every 5' to support pipe from above.
- Vent pipe through crawl space, use double wall vent pipe.
- Vent pipe passing through combustible wall or partition, use ventilated metal thimble. Thimble should be 4" larger in diameter than vent pipe.

NOTICE

Minimum Vent Pipe Clearance - Wood and other combustible materials must not be closer than 6" from any surface of single wall metal vent pipe. Listed Type B vent pipe or other listed venting systems shall be installed in accordance with their listing.

Removing Existing Boiler From Common Venting System

When an existing boiler is removed from a common venting system, the common venting system is likely to be too large for proper venting of the appliances remaining connected to it.

At the time of removal of an existing boiler, the following steps shall be followed with each appliance remaining connected to the common venting system placed in operation, while the other appliances remaining connected to the common venting system are not in operation.

1. Seal any unused openings in the common venting system.
2. Visually inspect the venting system for proper size and horizontal pitch and determine there is no blockage or restriction, leakage, corrosion and other deficiencies which could cause an unsafe condition.
3. Insofar as is practical, close all building doors and windows and all doors between the space in which the appliances remaining connected to the common venting system are located and other spaces of the building. Turn on clothes dryers and any appliance not connected to the common venting system. Turn on any exhaust fans, such as range hoods and bathroom exhausts, so they will operate at maximum speed. Do not operate a summer exhaust fan. Close fireplace dampers.

CHIMNEY AND VENT PIPE CONNECTION

- Place in operation the appliance being inspected. Follow the lighting instructions. Adjust thermostat so appliance will operate continuously.
- Test for spillage at the draft hood relief opening after 5 minutes of main burner operation. Use the flame of a match or candle, or smoke from a cigarette, cigar or pipe.
- After it has been determined that each appliance remaining connected to the common venting system properly vents when tested as outlined above, return doors, windows, exhaust fans, fireplace dampers and any other gas-burning appliance to their previous conditions of use.
- Any improper operation of the common venting system should be corrected so the installation conforms with the National Fuel Gas Code, ANSI Z223.1/NFPA 54. When re-sizing any portion of the common venting system, the common venting system should be resized to approach the minimum size as determined using the appropriate tables in Chapter 13 of the National Fuel Gas Code, ANSI Z223.1/NFPA 54.

Vent connectors serving appliances vented by natural draft shall not be connected into any portion of mechanical draft systems operating under positive pressure.

Figure 7 - Typical Masonry Chimney Requirements

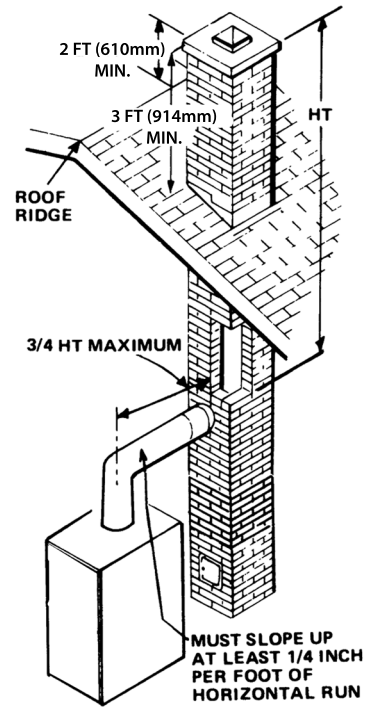

VENT DAMPER OPERATION

⚠ WARNING

Asphyxiation or burn hazard. Improper installation and operation of vent damper could result in serious injury or death due to fire or to asphyxiation from poisonous gases such as carbon monoxide which is odorless and invisible.

Vent Damper Installation - Follow all cautions and notes.

- Install vent damper to service only single appliance for which it is intended.
- Do not install vent damper with 6" (15mm) of combustible material.
- Do not install vent damper on vent pipe curve.
- Do not run wires near high temperature surfaces. Use standoff brackets if necessary.
- Install vent damper with actuator to sides of vent only. Do not mount above or below vent.

Check vent damper and all flue product carrying areas of boiler annually for deterioration from corrosion or other sources. If you see corrosion or other deterioration, contact your service agent for repairs.

Check vent damper operation as follows:

1. When boiler is off, check vent damper positions indicator points to closed position. See Figure 10.
2. Turn thermostat or controller up to call for heat and check vent damper indicator points to open position. See Figure 10.
3. Turn thermostat or controller down again and check damper position indicator returns to closed position.
4. Return thermostat to desired position.

Inspect vent damper at least once a year by trained service technician.

Manual Operation of Vent Damper

- Place vent damper in open position to permit burner operation by using "HOLD DAMPER OPEN" switch, located on damper controller.
- Thermostat controls burner firing as before, while damper remains open.
- **DO NOT** turn damper open manually, motor damage will result.
- Set switch to "AUTOMATIC OPERATION" to close vent damper during burner off cycle.
- For further information, and for vent damper troubleshooting guide, refer to manual packaged with vent damper.

Figure 8 - Horizontal Installation

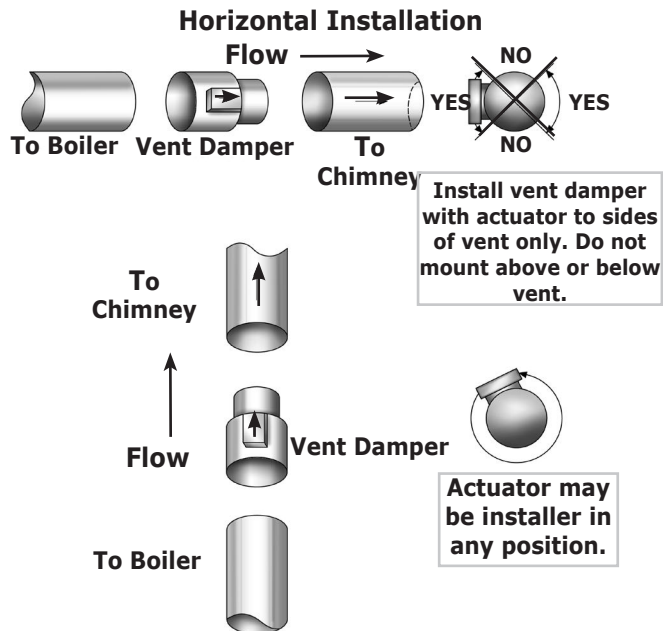

Figure 9 - Alternate Vent Damper Installation

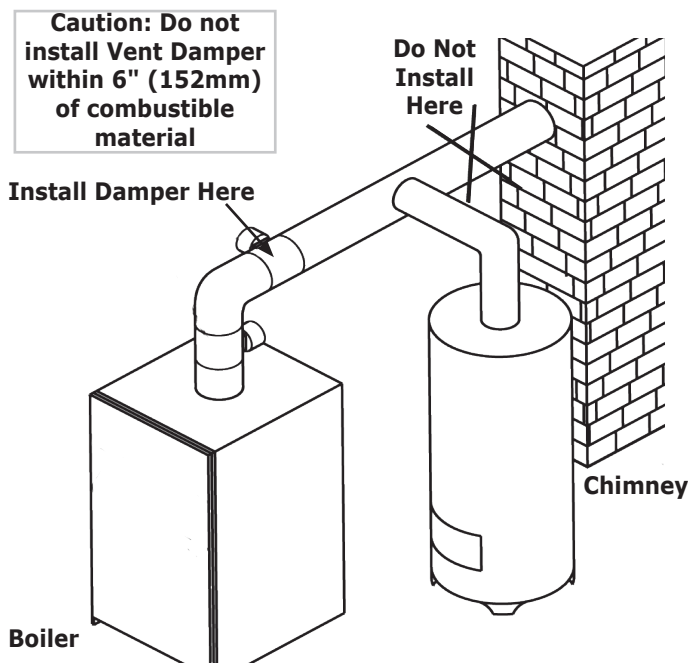
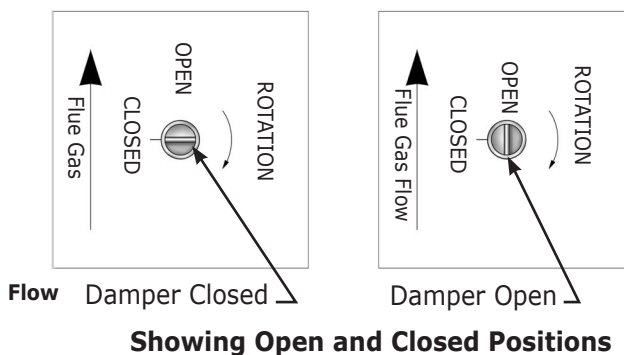

Figure 10 - Vent Damper Position Indicator



CAUTION

WHAT TO DO IF YOU SMELL GAS

- Do not try to light any appliance.
- Do not touch any electrical switch; do not use any phone in your building.
- Immediately call your gas supplier from a neighbor's phone. Follow gas supplier's instructions.
- If you cannot reach your gas supplier, call the fire department.

General

- Use piping materials and joining methods acceptable to authority having jurisdiction. In absence of such requirements National Fuel gas Code, ANSI Z223.1/ NFPA 54.
- Size and install gas piping system to provide sufficient gas supply to meet maximum input at not less than minimum supply pressure. See Tables 4a and 4b.

Length of Pipe - Ft.	Pipe Capacity - BTU Per Hour Input Includes Fittings			
	1/2"	3/4"	1"	1 -1/4"
20	92,000	190,000	350,000	625,000
40	63,000	130,000	245,000	445,000
60	50,000	105,000	195,000	365,000

Length of Pipe - Ft.	Pipe Capacity - BTU Per Hour Input Includes Fittings			
	5/8"	3/4"	1/2"	3/4"
20	131,000	216,000	189,000	393,000
40	90,000	145,000	129,000	267,000
60	72,000	121,000	103,000	217,000

*** Outside diameter**

Length of pipe or tubing should be measured from the gas meter or propane second stage regulator.

- Support piping with hooks straps, bands, brackets, hangers, or building structure components to prevent or dampen excessive vibrations and prevent strain on gas connection. Gas valve will not support piping weight.
- Use thread (joint) compound (pipe dope) suitable for natural and liquefied petroleum gas.
- Install field sourced manual main shutoff valve, ground joint union, and sediment trap upstream of gas valve. See Figure 11.

Propane Installation

WARNING

Fire, explosion, asphyxiation hazard. Verify boiler is equipped with propane gas orifices and gas valve is configured for propane. Failure to follow these instructions may result in serious injury or death.

- Connections by licensed propane dealer only.
- Use two stage regulator provided by propane supplier.
- Have propane supplier check piping.

DANGER

Fire Hazard. Do not use matches, candles, open flames, or other methods providing ignition source. Failure to comply will result in death or serious injury.

Leak Check Gas Piping

Pressure test boiler and gas connection before placing boiler in operation. Avoid excessive pressure that could damage pressure regulators, valves, or meters.

- Pressure test at 1/2 psig (3.5 kPa) or less. Isolate boiler from gas supply system by closing manual gas shutoff valve.
- Locate leakage using gas detector, noncorrosive detection fluid, or other leak detection method acceptable to authority having jurisdiction. Do not use matches, candles, open flames, or other methods providing ignition source.
- Correct leaks immediately and retest.

Figure 11 - Gas Piping At Boiler

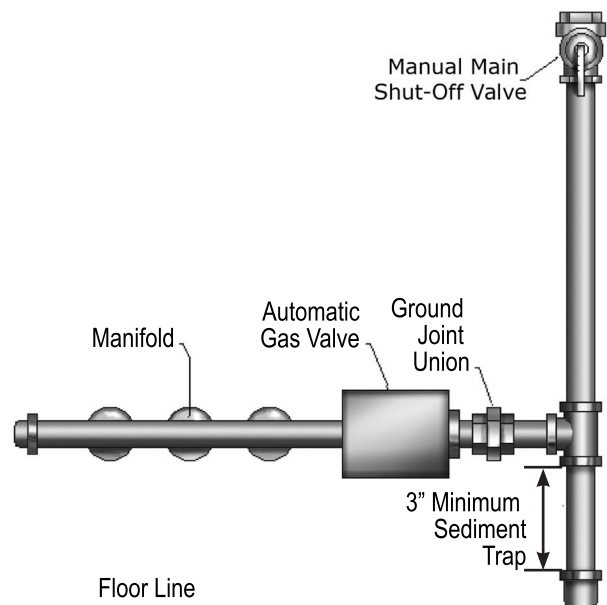

WARNING

Electrical shock hazard. Turn OFF electrical power supply at service panel before making electrical connections. Failure to do so could result in death or serious injury.

NOTICE

Label all wires prior to disconnection when servicing controls. Wiring errors can cause improper and dangerous operation. Verify proper operation after servicing.

Electric Power Supply

Electrically bond boiler to ground in accordance with requirements of authority having jurisdiction. Refer to National Electrical Code, ANSI/NFPA 70.

Line Voltage Connections

- A. Provide individual 120V, 15 amp circuit (recommended) with fused disconnect or service switch as required by authority having jurisdiction.
- B. Locate a shut-off switch at the boiler.
- C. Connect 115V electrical supply to primary leads on 24 volt transformer. Securely fasten with wire nuts.
- D. Set heat anticipator at 0.6 amps for boilers equipped with intermittent ignition. Connect 24 volt thermostat leads to two wires tagged "24 volt thermostat" on boiler.
- E. Boilers with 67D-1 float type low water cut-off, two wires are black. One wire is located on secondary of 24 volt transformer, second wire is located on pressure limit control.
- F. Boilers with PS-802 probe type low water cut-off, one wire is green and is located on terminal B of PS-802, second wire is black and located on pressure limit control.

VENT DAMPER

Boiler is equipped with factory wired 4 pin molex harness, that plugs into 4 pin molex receptacle inside vent damper control.

Vent damper must be connected for boiler to operate.

Thermostat Installation

1. Install thermostat on inside wall per manufacturer's instructions.
2. NEVER install thermostat on outside wall.
3. Do not install thermostat where it will be affected by drafts, hot or cold pipes, sunlight, lighting fixtures, televisions, fireplace, or chimney.
4. Check thermostat operation by raising and lowering thermostat setting as required to start and stop burners.
5. Instructions for final adjustment of thermostat see manufacturer's instructions.

Electronic Thermostats

- A. Some electronic thermostats may lose their memory or shut down. With probe type low water cutoff, this may occur each time low water cutoff detects low water condition. If this is the case, an isolation relay is required for thermostat circuit. A 24 volt single pole single throw (SPST) normally open (N.O.) relay is required, such as Honeywell R8222A or equivalent. Wire as shown in Figure 12a or Figure 12b.
- B. Some electronic thermostats are not acceptable for use with steam systems, check manufacturer suggested use.

Figure 12a - Isolation Relay Wiring For Steam Boilers With Float Type Low Water Cut Off And Use of Electronic Thermostat

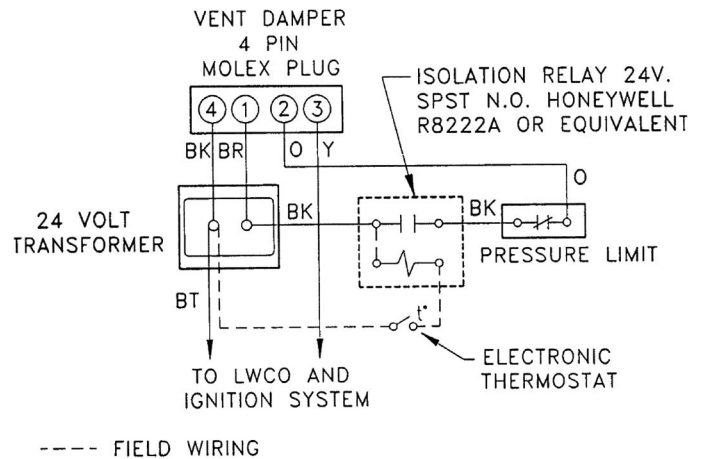
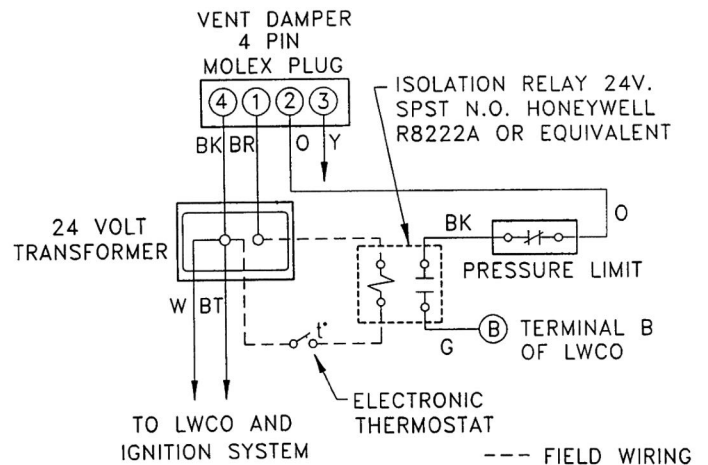

Figure 12b - Isolation Relay Wiring For Steam Boilers With Probe Type Low Water Cut Off And Use of Electronic Thermostat



OPERATING INSTRUCTIONS

For Your Safety Read Before Operating

⚠ WARNING

If you do not follow these instructions exactly, a fire or explosion may result causing property damage, personal injury or loss of life.

- This appliance is equipped with an ignition device which automatically lights burner. **Do NOT try to light this burner by hand.**
- Before operating smell all around appliance area for gas. Be sure to smell next to floor because some gas is heavier than air and will settle to the floor.
- **Use only your hand to turn the gas shutoff valve.** Never use tools. If valve will not turn by hand, do not try to repair it, call a qualified service technician. Force or attempted repair may result in fire or explosion.
- **Do not use this appliance if any part has been under water.** Immediately call a qualified service technician to inspect appliance and to replace any part of control system and any gas control which has been under water.

⚠ CAUTION



WHAT TO DO IF YOU SMELL GAS

- Do not try to light any appliance.
- Do not touch any electrical switch; do not use any phone in your building.
- Immediately call your gas supplier from a neighbor's phone. Follow gas supplier's instructions.
- If you cannot reach your gas supplier, call the fire department.

1. STOP! Read the safety information on this page.
2. Set the thermostat to lowest setting.
3. Turn off all electric power to the appliance.
4. This appliance is equipped with an ignition device which automatically lights the pilot. Do **not** try to light the pilot by hand.

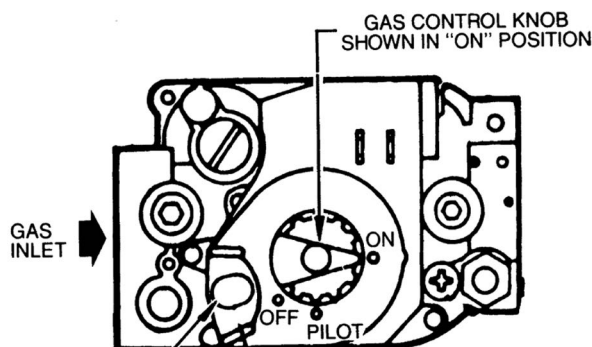
Figure 13 - Gas Valve



5. Remove lower front panel.
6. Rotate the gas control knob clockwise  to "OFF".
7. Wait five (5) minutes to clear out any gas. Then smell for gas, including near the floor. If you smell gas, STOP! Follow "B" in the safety information on this page. If you don't smell gas, go to next step.
8. Rotate the gas control knob counterclockwise  to "ON."
9. Replace lower front panel.
10. Turn on all electric power to the appliance.
11. Set thermostat to desired setting.
12. If the appliance will not operate, follow the instructions "To Turn Off Gas To Appliance" and call your service technician or gas supplier.

TO TURN OFF GAS TO APPLIANCE

1. Set the thermostat to lowest setting.
2. Turn off all electric power to the appliance if service is to be performed.
3. Push in gas control knob slightly and turn clockwise  to "OFF" Do not force.

WARNING

Burn Hazard. Never run water into a hot empty boiler. Failure to follow these instructions could result in death or serious injury.

Filling System With Water

Steam heating systems boiler is partially filled with water. Fill boiler to correct level for proper system operation.

Correct water level is about halfway up glass water level gauge as marked on boiler jacket.

1. Close boiler drain valve.
2. Open valves at top and bottom of glass water level gauge.
3. Open fill valve. Allow water to run into boiler.
4. Allow boiler to fill until water runs out gauge drain valve. Then close gauge drain valve.
5. Continue to fill boiler until water reaches indicated water line about halfway up glass gauge.

Water Level

- Normal water level is 24" above the floor as shown on left side of boiler.
- Determine water level when boiler is off and cold, when all water in the system is inside the boiler and return piping below water line, and everything above water line is air, no steam.
- When boiler is making steam, water level drops two to three inches below normal water line.

Thermostat

- A. Set thermostat to desired room temperature.
- B. Set thermostat to lower setting if heat is not required
- C. System is self-checking. If failure of any component system will not operate or will go into safety lockout.
- D. On call for heat, each component must function properly to permit operation.
- E. Turn thermostat to lowest setting for one minute and back to normal setting to reset on safety lockout.

Adjust Pilot Burner

Pilot flame should surround 3/8" to 1/2" of pilot sensor. See Figure 15.

To adjust Flame.

1. Remove screw cover over pilot adjusting screw. See Figure 13.
2. Insert small screwdriver and adjust flame as needed. Turn screw counterclockwise to increase flame, clockwise to decrease.
3. Replace screw cover over pilot adjusting screw.

Main Burners

- Main burners do not require primary air adjustment and are not equipped with primary air shutters.
- Main burner flames form sharp blue inner cones in softer blue outer mantel, with no yellow. Remain still when observing main burner flames.
- Check main burner orifices, burner throat and flame ports for dust and lint obstruction if flame appearance is not correct.
- Remove rollout shield if necessary to observe main burner flames.
- Replace rollout shield after observation.

Gas Valve Safety Shutdown Test

1. Test ignition system safety shutoff device after placing boiler in operation.
2. Boilers equipped with intermittent ignition, with main burners firing, disconnect ignition cable from intermittent pilot control box. Gas valve will shut off main burners.
3. **TURN OFF ELECTRIC POWER** to boiler before reconnecting ignition cable, to prevent electric shock.

Figure 14 - Igniter

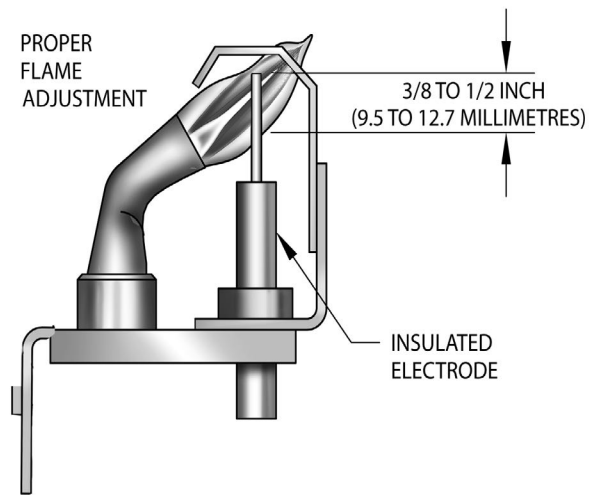
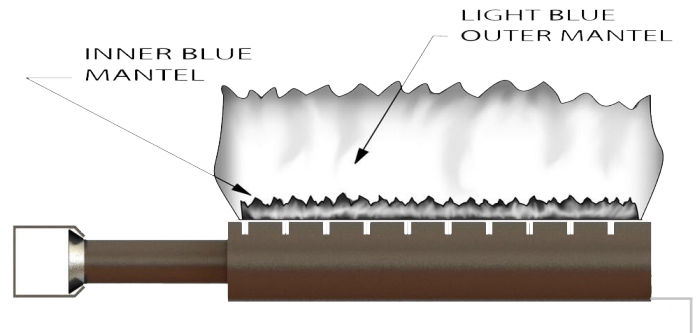

Figure 15 - Main Burner



Adjust Steam Pressure Control

- Steam pressure limit control (pressuretrol) shuts off gas to main burners when steam pressure in boiler reaches cut-off setpoint (i.e. sum of cut-in and differential setpoints).
- Burners refire when steam pressure drops to cut-in setpoint.
- System pressure requirements are based on size and condition of pipes, and load.
- Cut-in setting of pressuretrol should never be less than twice system pressure drop for good system operation.
 - A. In typical single family residence with clean one-pipe heating system and cast iron radiation, cut-in is usually set at minimum setting, i.e. 1/2 psi.
- Steam radiation is sized based on square feet of equivalent direct radiation (EDR). This is based on steam pressure in the radiator of just less than 2 psi.
- Set differential adjustment at 1 psi, i.e. steam pressure required in radiators. Results in cut-off setpoint of 1½ psi.
- Larger systems or other types of systems such as two pipe systems, or systems with convectors or fan coil units, pressuretrol settings need to be determined on system-by-system basis.
- Cut-in setpoint is determined by system pressure drop to furthest radiator or terminal unit. Double system pressure drop as safety factor, resulting in the rule cut-in setting should never be less than twice system pressure drop.
- Differential setpoint is steam pressure required at terminal heating units.

Boiler will now operate in correct pressure range. It maintains enough steam pressure to send steam out to furthest radiator, and not go over optimum steam pressure required at the radiators.

Checking Controls

Low Water Cut-Off

- A. Turn off power to boiler or turn thermostat down to lowest setting.
- B. Drain water to below visible bottom of water gauge glass. Turn power on and turn thermostat to call for heat.
- C. Gas valve opens for approximately 10 seconds (time delay on probe type LWCO), gas valve will close and red indicator illuminates on LWCO.
- D. When water is restored, it waits 30 seconds before reactivating burner circuit.

Boiler Equipped With Optional WF-2U-24 Water Feeder

- E. Continue thermostat call for heat after low water cut off recognizes low water condition.
 - F. One minute time delay, water feeder starts feeding water to boiler.
 - G. Feeder feeds for one minute, and then goes into another one minute waiting period.
 - H. Cycle of alternately waiting and feeding will repeat until :
 - For Model 67D-1 float type low water cutoffs - as the water level raises the float above the burner cut off switch level, the burners should ignite. The water feeder remains powered until the water level raises the float to the water feeder switch level, satisfying the water feeder.
 - For probe type low water cutoffs - the water level will rise until water in the boiler makes contact with the probe, satisfying the water feeder, and igniting the burners.
 - I. In either case, one and two inches of water should be visible in glass gauge when both water feeder is satisfied, and burners are allowed to ignite.
- Time delays in feed cycles are designed to prevent boiler from flooding due to slow return lines.
 - To check pressure limit, run boiler until pressure reaches system demand. Turn pressure screw and drop pressure setting until boiler shuts down. This shows the pressure limit is operating properly.
 - Refer to control manufacturer's instructions for more information.

Check Thermostat Operation

Thermostat set above temperature indicated on thermometer, boiler should ignite.

Verify thermostat turns boiler off when room temperature reaches selected setting and starts boiler operating when room temperature falls few degrees.

Set thermostat for desired temperature. Conditions in your home and location of thermostat will govern this setting.

START-UP CLEANING

WARNING

Following service procedures must be performed by qualified service agent. Boiler owner shall not attempt these steps. Failure to do so could result in death or serious injury.

It is very important to clean a new steam boiler after it has been installed and put into continuous operation.

This must be done to remove any accumulation of oil, grease, sludge, etc., that may have been present in system. These substances may cause boiler water to foam and surge, producing an unsteady water line, throwing water into steam header, and possibly preventing steam generation.

Follow skimming and blow-down steps in order to remove contaminants.

Skimming and Blow-down

WARNING

Burn Scald Hazard. Water temperatures in excess of 125°F. Failure to follow these instructions could result in death or serious injury.

New boilers must be skimmed at time of installation to remove threading oil and other impurities that float on surface of water.

1. Remove cap from skimmer female adapter tee and pipe to floor drain or bucket. See Figures 4 and 5 page 9. Raise water level to skimmer tapping.
2. Fire burners to maintain water temperature of 180-200°F.
3. Feed water to boiler to maintain water level. Adjust water feed rate to maintain continuous flow of 1 gallon per minute. Do not allow boiler to steam.
4. Continue skimming until water runs clear. This may take several hours.
5. Drain boiler completely to remove any foreign material.
6. Fill boiler to water line.
 - Fire burners, allow normal steam pressure to build up.
 - Run connection from boiler drain valve to safe discharge point outside.
 - Shut off gas burners, open drain valve, allow all of water in boiler to drain out.
 - Close drain valve.
 - Allow boiler to cool, slowly refill boiler to water line.
 - Repeat this step as many times as necessary until blow-down water is clear.
7. Following final blow-down, allow boiler to cool.
 - Add fresh water slowly up to normal water line.
 - Start burners.

- Maintain at least 180°F for 15 minutes to remove dissolved gasses from fresh water.
 - Shut off burners.
8. Allow system to operate for one week to give majority of system dirt a chance to work its way back to boiler.
 - Check water in gauge glass. Gauge glass should be dry above water line.
 - Water line should not bounce more than one inch when boiler is steaming.
 - If you see water droplets carrying over from top of gauge glass, or excessive bouncing of water line, boiler needs further cleaning.
 - Take water sample and boil it on stove to see if it foams. If it does, this indicates boiler needs to be cleaned.

NOTICE

Clean water with no additives is essential to proper operation of your boiler and heating system. Boiler cleaners and chemical cleaning, if used and not rinsed properly, may be harmful to the system.

If cleaning is necessary, repeat skimming and blow-down procedure above. A long skim will be all you need to clean the boiler.

In more troublesome cases it may be desirable to flush the system while, in very extreme cases, it may be necessary to chemically clean and flush heating system.

Consult boiler manufacturer before introducing any chemicals into boiler.

Check water level frequently. Be sure top and bottom valves on gauge are always open so actual water level is shown at all times.

Low Water Cut-Off

Low Water Cut-Off interrupts electrical current to burner when water line in boiler drops to low level.

Check Low Water Cut-Off monthly to verify it is providing proper protection. See "Checking and Adjusting" on page 21.

Remove Low Water Cut-Off probes beginning of each heating season for inspection and cleaning. More cleaning may be required on boilers requiring frequent additions of make up water.

Boiler Flue Passages and Burners

Beginning of heating season visually check pilot and main burner flames. See page 19.

Recommend you have flue passages, burner adjustment, and operation of controls checked once each year by trained Service Technician.

Before start of each season or whenever system has been shut down for some time, check system, boiler and vent pipe for leaks.

Vent Pipe

Check vent piping at least once a season. Verify vent pipe connections to chimney are secure and no obstructions are present. If vent piping shows sign of leaking, replace it immediately.

Safety Valve

See Manufacturer's Instructions.

Cleaning Boiler Flue Passages and Burners

1. Remove burners, pilot, vent pipe, top and front jacket panels. Remove hold-down nuts and bolts from flue collector.
2. Use putty knife to cut through silicone. Lift flue collector off boiler sections. Remove old silicone material.
3. Clean passageways between sections with flue brush. Remove dirt from bottom of boiler and from between sections by vacuuming.
4. Verify all flame ports in burners are open and clear. Shake or blow out loose dirt in burners.
5. Apply generous bead of 400°F RTV silicone to four mounting surface flanges of flue collector. Mount flue collector on heat exchanger. Tighten nuts and bolts.
6. Seal front edge and four corners of flue collector to heat exchanger with silicone sealant.
7. Use flashlight to verify there are no gaps in silicone seal.
8. Install draft diverter, vent damper, vent pipe, and jacket top and front cover.
9. Reassemble all parts.
10. Check tightness of pilot connections and condition of burner flames after reassembly. See Figures 14 and 15.

Boiler Water Treatment Other Than Cleaners

In steam systems where system is tight, free from leaks, and all steam is returned to boiler as condensate, amount of make up water is small. Water treatment is generally not required.

In steam systems with less than 90% of steam being returned as condensate, or with very hard or corrosive make up water, treatment may be desirable. Follow recommendations of your local boiler water treatment specialist.

Foaming, Priming, or Surging

These terms are used to describe a fluctuating water line when water leaves boiler with steam. It is caused by any combination of following:

1. Threading oil and organic matter in boiler water. Follow instructions under "Start-up Cleaning."
2. Faulty quick vents that do not release air until sizeable pressure is built up - if old style, replace - if dirty, clean until you can easily blow through valve.
3. Adjustment of steam limit control to wide differential increases difficulty if quick vents are old style, slow-releasing type or dirty. Always set steam limit control differential as low as possible.
4. Soap and chemicals in boiler water cause extreme surging. Boiler cleaners and chemical cleaning additives are not recommended. If used and not rinsed properly, may be harmful to the system.

SERVICE HINTS

You may avoid inconvenience and service calls by checking these points before you call for service.

CAUTION
<p>WHAT TO DO IF YOU SMELL GAS</p> <ul style="list-style-type: none"> Do not try to light any appliance. Do not touch any electrical switch; do not use any phone in your building. Immediately call your gas supplier from a neighbor's phone. Follow gas supplier's instructions. If you cannot reach your gas supplier, call the fire department.

IF YOUR SYSTEM IS NOT HEATING OR NOT GIVING ENOUGH HEAT . . .	
Possible Cause	What to do
Thermostat is not set correctly	Reset thermostat above room temperature.
Burner is not operating properly	Inspect flame. If yellow, burner is not getting enough air. If blue and noisy and seems to lift off burner, burner is getting too much air. Contact service technician.
No electric power to boiler	Verify electric power supply circuit is "ON". Contact your service technician to verify over current protection.
Controls out of adjustment	Reset according to instructions.
Radiators not heating	Inspect steam air vents for proper operation. Contact service technician to inspect for faulty steam traps.
Poor electrical contact	Contact your service technician to inspect all control terminals and wire joints.
Rollout switch blown	Have your service technician check heat exchanger for blockage.
Chimney flue is blocked	Spill switch contacts open, requiring manual reset of spill switch. Have your service technician check and correct chimney problem.
Vent damper not operating	Consult troubleshooting guide, packaged with vent damper.
IF BURNER IS NOISY . . .	
Gas input amount is incorrect	Contact your service technician.
IF WALLS OR WINDOWS SWEAT . . .	
Not enough ventilation	Contact your service technician
Chimney flue is blocked	Contact service technician to inspect and correct, if necessary.
IF RADIATORS ARE NOISY . . .	
Air in system	refer to "Radiators Not Heating" above
SAFETY VALVE LEAKING . . .	
Dirt on seat	Contact service technician.
HAVE YOUR SERVICE TECHNICIAN CHECK ANY PROBLEM YOU ARE UNABLE TO CORRECT.	

WIRING DIAGRAMS

Figure 13 - Wiring Diagrams For Boilers With PS-802 Probe Type Low Water Cut-Off

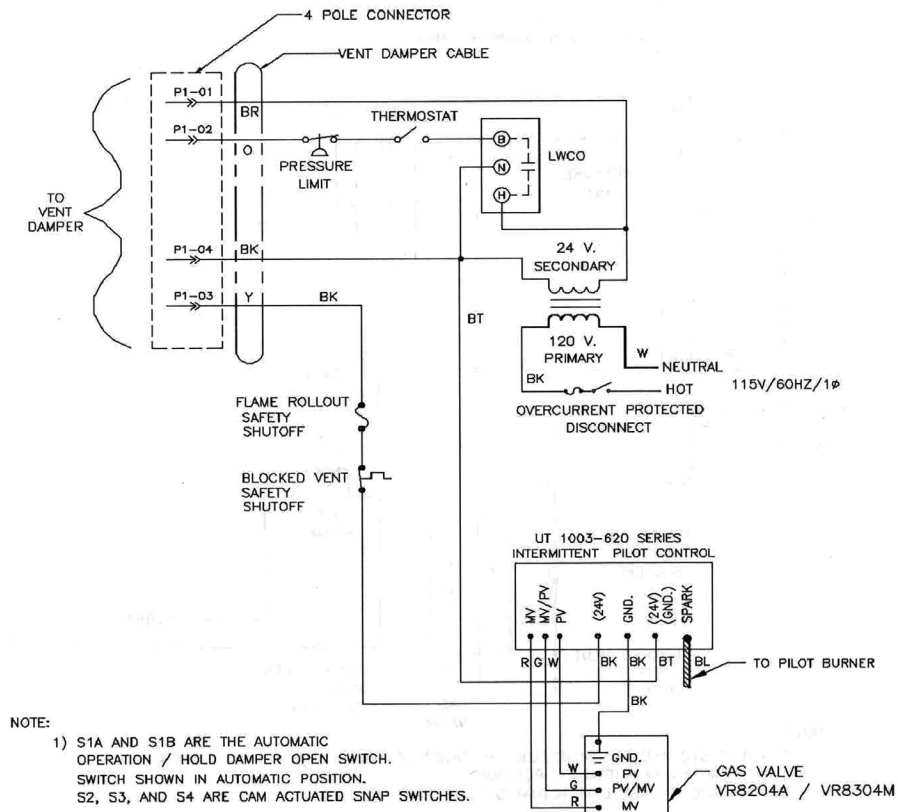
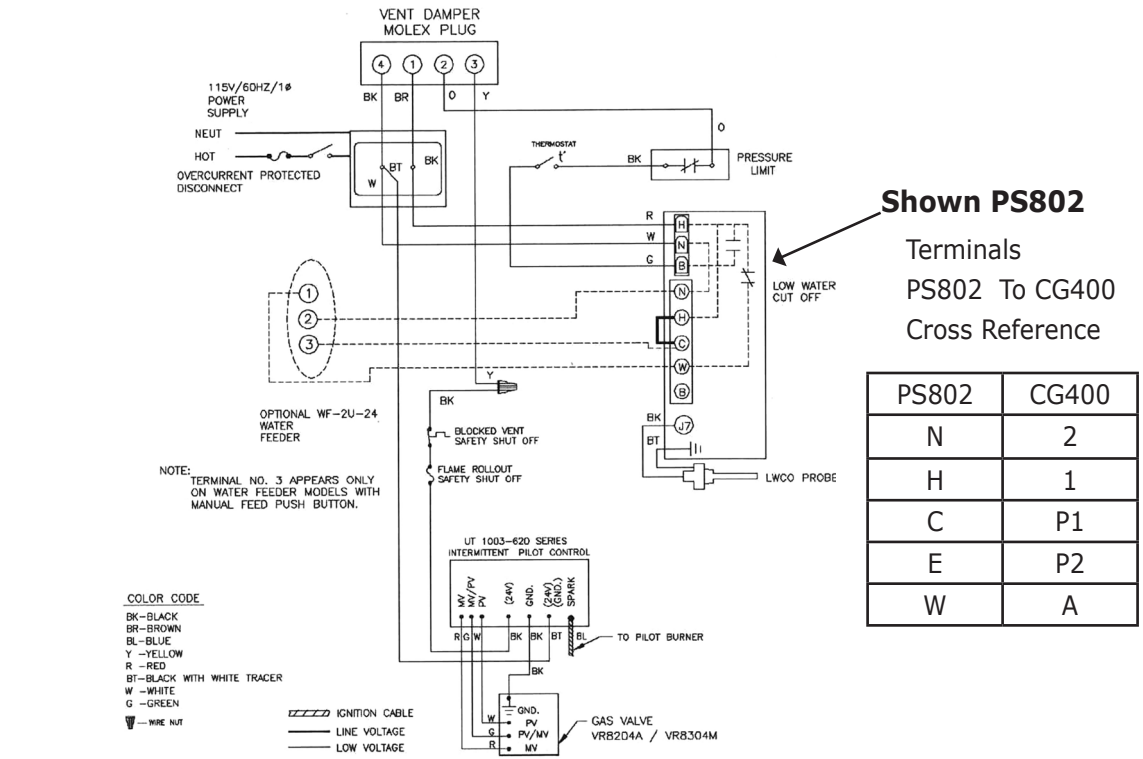

If any of the original wire as supplied with this appliance must be replaced, it must be replaced with type 105°C Thermoplastic wire or its equivalent.

WIRING DIAGRAMS

Figure 17 - Wiring Diagrams For Boilers With 67D-1 Float Type Low Water Cut-Off

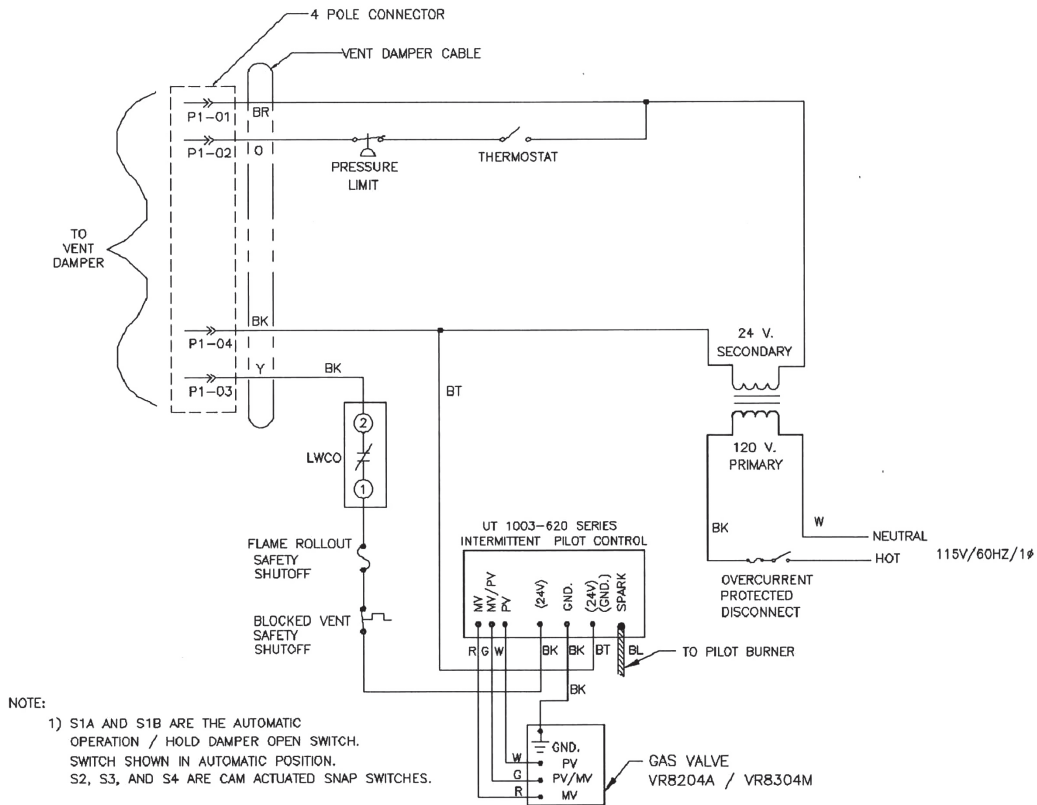
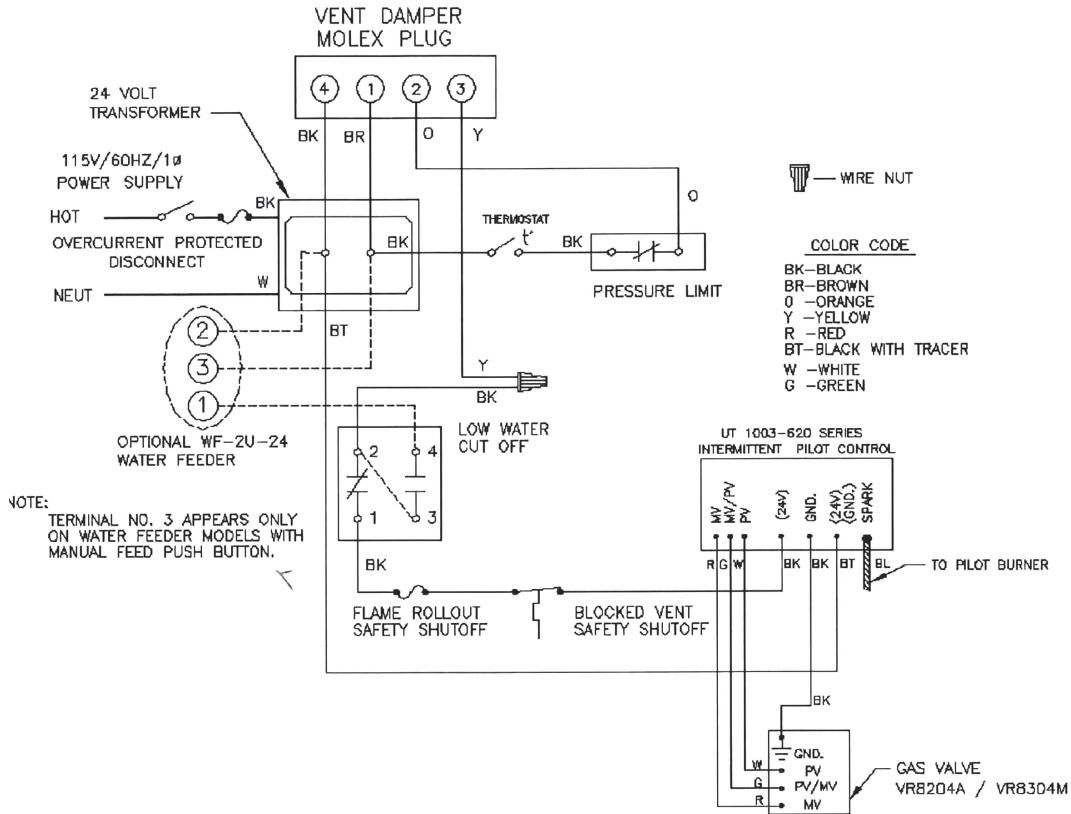

If any of the original wire as supplied with this appliance must be replaced, it must be replaced with type 105°C Thermoplastic wire or its equivalent.

SAFETY VALVE

Safety valve is designed to open automatically if boiler steam pressure exceeds pressure rating of valve (15 psig). Should it fail to open under this condition, shut down your boiler. If valve discharge occurs, or valve fails to open as described above, contact a qualified service technician to replace safety valve and inspect heating system to determine cause, as this may indicate equipment malfunction.

STEAM PRESSURE GAUGE

Boiler is equipped with pressure gauge installed. Gauge enables monitoring of the pressure in the system. If safety devices fail to shut off your boiler at proper settings, notify your serviceman immediately.

WATER LEVEL GAUGE

Boiler water level can be seen through glass tube in water level gauge at side of boiler. Correct cold boiler water level is stamped on side jacket panel. Check water level regularly for proper level.

Located on right side of boiler jacket panel, there are three holes for glass water level gauge. Top hole is common for both types of low water cut off, and is used for upper gauge glass fitting. Middle hole, 9" down from top hole, is used for bottom gauge glass fitting for the Model 67D-1 and 47-2 float type low water cut off. Lowest hole, 12¹/₄" down from top hole, is used for bottom gauge glass fitting for Model PS-802 probe type low water cut off. Cover unused with sheet metal knockout.

STEAM PRESSURE CONTROL

Steam pressure limit control (pressuretrol) shuts off gas to main burners when steam pressure in boiler reaches cut-off setpoint (i.e. sum of cut-in and differential setpoints). Burners refire when steam pressure drops to cut-in setpoint. System pressure requirements are based on size and condition of pipes, and load.

LOW WATER CUT-OFF

Model 67D-1

Float operated switch which shuts down gas burner if water falls below visible bottom of gauge glass.

Probe Type Models

Electronic probe type LWCO. Probe is located inside boiler. LWCO will shut down burners if water loses contact with probe for 10 seconds.

Refer to manufacturer's instructions (enclosed) for more information.

WATER FEEDER (Optional)

Model WF-2U-24 water feeder maybe used with either of the low water cutoffs listed. Water feeder maintains safe minimum water level. Keeps boiler running by compensating for minor evaporative steam leaks, and prevents freeze-ups if homeowners are away and return line leaks.

McDonnell and Miller Model 101 water feeders may be used, however water feed rates are too high and need to be regulated or throttled and wiring will have to be revised. Consult boiler manufacturer before using these or any other non-standard types of controls.

Automatic water feeder is safety device, not convenience item. It is not designed to maintain "normal" water line. Water feeder does not take place of responsible person monitoring and maintaining normal water line. Steam boilers require attention.

VENT DAMPER

Automatic, motorized stack damper developed to increase efficiency of heating systems by reducing standby losses from boiler and conditioned air space. Damper closes chimney vent when burner is off and fully opens it when combustion is required.

ROLLOUT SWITCH

(FLAME ROLLOUT SAFETY SHUTOFF)

Rollout switch is temperature-sensitive fuse link device. Located on boiler base just outside fire box. In event of heat exchanger flueway blockage causing flame to roll out of fire box, fuse will blow, shutting down flow of gas to main burners. Fuse does not change in appearance when blown. If rollout switch blows, replace with exact replacement. Check heat exchanger flueways for blockage when restoring system to operating condition. Do not operate system without rollout switch.

SPILL SWITCH

(BLOCKED VENT SAFETY SHUTOFF)

Spill switch is manual reset disc thermostat with fixed setpoint (280° F), and normally closed contacts. It is located at relief opening of draft diverter. In event of chimney or venting system blockage causing products of combustion to spill out of relief opening, spill switch disc heats up and spill switch contacts open, shutting down flow of gas to main burners by removing power to gas valve.

In event spill switch contacts open, reset button on back of switch will pop up. Manually reset spill switch after switch has cooled off, push reset button down. Check venting system and chimney for blockage when restoring system to operating condition. **DO NOT** operate boiler without spill switch.

GAS – FIRED STEAM BOILERS

– IMPORTANT –

READ THESE INSTRUCTIONS BEFORE ORDERING

All parts are listed in the following Parts List may be ordered through your nearest supplier.

When ordering parts, first obtain the Model Number from the data plate on your boiler, than determine the Part No. (not the Key No.) and the Description of each part from the following illustrations and list. Be sure to give us all this information:

The Part No. – The Part Description – The Boiler Model No.

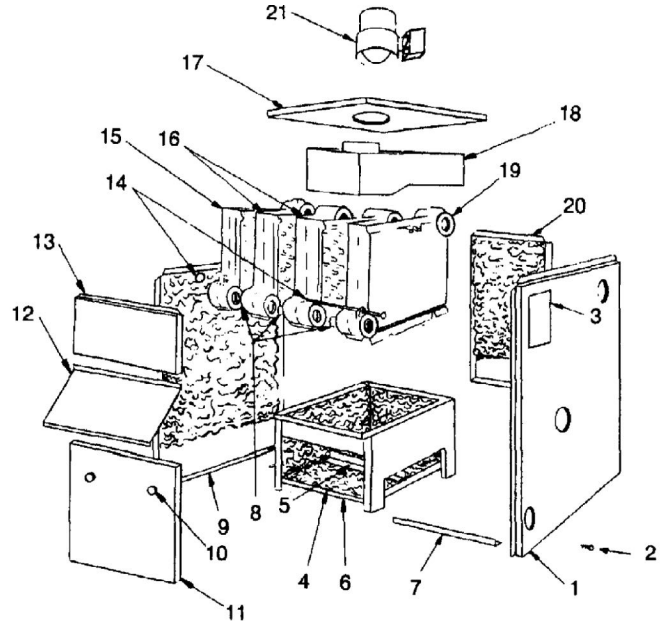

JACKET - SECTION AND BASE PARTS

THIS IS A REPAIR PARTS LIST - NOT A PACKAGING LIST

KEY NO.	DESCRIPTION	3 SECTION	4 SECTION	5 SECTION	6 SECTION	7 SECTION	8 SECTION	9 SECTION
		Part No.	Part No.	Part No.	Part No.	Part No.	Part No.	Part No.
1	Jacket, Right Side Panel	425-00-802	425-00-802	425-00-802	425-00-802	425-00-802	425-00-802	425-00-802
2	#10 x 1/2 Sheet Metal Screw	146-95-074	146-95-074	146-95-074	146-95-074	146-95-074	146-95-074	146-95-074
3	Rating Plate	146-80-901	146-80-901	146-80-901	146-80-901	146-80-901	146-80-901	146-80-901
4	Base Insulation - Base Sides (2)	146-14-130	146-14-130	146-14-130	146-14-130	146-14-130	146-14-130	146-14-130
	- Base Front	146-14-113	146-14-114	146-14-115	146-14-116	146-14-117	146-14-118	146-14-119
	- Base Rear	146-14-123	146-14-124	146-14-125	146-14-126	146-14-127	146-14-128	146-14-129
5	Base Baffle	425-00-643	425-00-644	425-00-645	425-00-646	425-00-647	425-00-648	425-00-649
6	Base	425-00-663	425-00-664	425-00-665	425-00-666	425-00-667	425-00-668	425-00-669
7	Jacket Tie Bar	425-00-653	425-00-654	425-00-655	425-00-656	425-00-657	425-00-658	425-00-659
8	Push Nipple	433-00-976	433-00-976	433-00-976	433-00-976	433-00-976	433-00-976	433-00-976
9	Jacket, Left Side Panel	425-00-801	425-00-801	425-00-801	425-00-801	425-00-801	425-00-801	425-00-801
10	Knob, Service Door (Pair)	137-02-153	137-02-153	137-02-153	137-02-153	137-02-153	137-02-153	137-02-153
11	Jacket, Service Door	425-00-823	425-00-824	425-00-825	425-00-826	425-00-827	425-00-828	425-00-829
12	Jacket, Int'd. Panel	425-00-813	425-00-814	425-00-815	425-00-816	425-00-817	425-00-818	425-00-819
13	Jacket, Front Panel	425-00-811	425-00-804	425-00-805	425-00-806	425-00-807	425-00-808	425-00-809
14	1/4" Tie Rod, Nut	146-05-001	146-05-002	146-05-051	146-05-053	146-05-005	146-05-007	146-05-009
15	Boiler Section, Left	410-00-013	410-00-013	410-00-013	410-00-013	410-00-013	410-00-013	410-00-013
16	Boiler Section, Middle	410-00-015	410-00-015	410-00-015	410-00-015	410-00-015	410-00-015	410-00-015
17	Jacket, Top Panel	425-00-843	425-00-844	425-00-845	425-00-846	425-00-847	425-00-848	425-00-849
18	Draft Diverter	425-00-673	425-00-674	425-00-675	425-00-676	425-00-677	425-00-678	425-00-679
19	Boiler Section, Right	410-00-014	410-00-014	410-00-014	410-00-014	410-00-014	410-00-014	410-00-014
20	Jacket, Back Panel	425-00-833	425-00-834	425-00-835	425-00-836	425-00-837	425-00-838	633-00-1029
‡	Jacket Complete	425-00-873	425-00-874	425-00-875	425-00-876	425-00-877	425-00-878	425-00-879
‡	Block Assembly (19, 16, 15, 14, 8)	410-00-330	410-00-430	410-00-530	410-00-630	410-00-730	410-00-830	410-00-930
‡	Combustable Floor Plate	146-14-031	146-14-031	146-14-031	146-14-031	146-14-032	146-14-032	146-14-032
‡	Cerafelt Gasket	146-14-018	146-14-018	146-14-018	146-14-018	146-14-018	146-14-018	146-14-018
21	Vent Damper	118-20-05	118-20-06	118-20-06	118-20-07	118-20-07	118-20-07	118-20-07
‡	Base Assembly (6, 5, 4)	433-00-663	433-00-664	433-00-665	433-00-666	433-00-667	433-00-668	433-00-669
‡	Rollout Switch Bracket (Nat. Gas Only)	425-00-604	425-00-605	425-00-606	425-00-607	425-00-608	425-00-609	425-00-610

‡ Not illustrated

FOR USE WITH NATURAL GAS ONLY

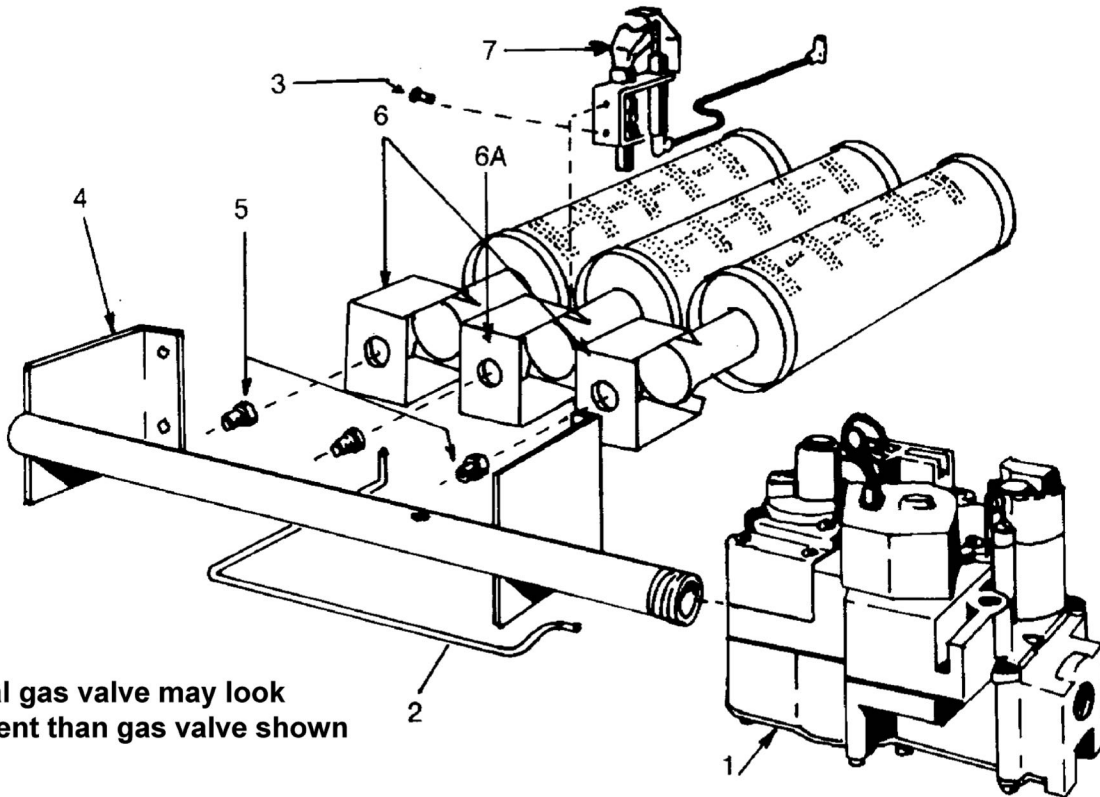

NOTE: Actual gas valve may look different than gas valve shown

NATURAL GAS BURNERS AND MANIFOLD PARTS

THIS IS A REPAIR PARTS LIST - NOT A PACKING LIST

ELECTRONIC INTERMITTENT IGNITION (Shown)

KEY NO.	DESCRIPTION	3 SECTION	4 SECTION	5 SECTION	6 SECTION	7 SECTION	8 SECTION	9 SECTION
		Part No.	Part No.	Part No.	Part No.	Part No.	Part No.	Part No.
1	24 Volt Gas Valve, Elect. Inter. Ignition	146-62-052	146-62-052	146-62-052	146-62-058	146-62-058	146-62-058	146-62-058
2	Pilot Tube	146-15-005	146-15-005	146-15-005	146-15-005	146-15-005	146-15-005	146-15-005
3	10-32 3/16 Hex Hd. Screw	146-95-301	146-95-301	146-95-301	146-95-301	146-95-301	146-95-301	146-95-301
4	Gas Manifold	146-16-033	146-16-034	146-16-035	146-16-013	146-16-014	146-16-015	146-16-016
5	Main Burner Orifice*	146-15-031	146-15-031	146-15-031	146-15-035	146-15-035	146-15-035	146-15-035
6	Main Burner, Regular**	146-15-532	146-15-532	146-15-532	146-15-532	146-15-532	146-15-532	146-15-532
6A	Main Burner, Pilot Mount	146-15-531	146-15-531	146-15-531	146-15-531	146-15-531	146-15-531	146-15-531
7	Pilot Burner	146-62-092	146-62-092	146-62-092	146-62-092	146-62-092	146-62-092	146-62-092
‡	Rollout Shield	425-00-933	425-00-934	425-00-935	425-00-936	425-00-937	425-00-938	425-00-939

ALTERNATE PARTS FOR CONTINUOUS PILOT - 24 VOLT

1	24 Volt Gas Valve, Continuous Pilot	146-62-051	146-62-051	146-62-051	146-62-060	146-62-060	146-62-060	146-62-060
3	10-32 3/16 Hex Hd. Screw (2 req'd)	146-95-301	146-95-301	146-95-301	146-95-301	146-95-301	146-95-301	146-95-301
7	Pilot Burner	146-62-098	146-62-098	146-62-098	146-62-098	146-62-098	146-62-098	146-62-098
‡	Thermocouple	152-00-01	146-62-039	146-62-039	146-62-039	146-62-039	146-62-039	146-62-039

Quantity is 1 unless otherwise noted.

* Requires 1 less than the number of sections.

** Requires 2 less than the number of sections

‡ Not Illustrated

FOR USE WITH PROPANE GAS ONLY

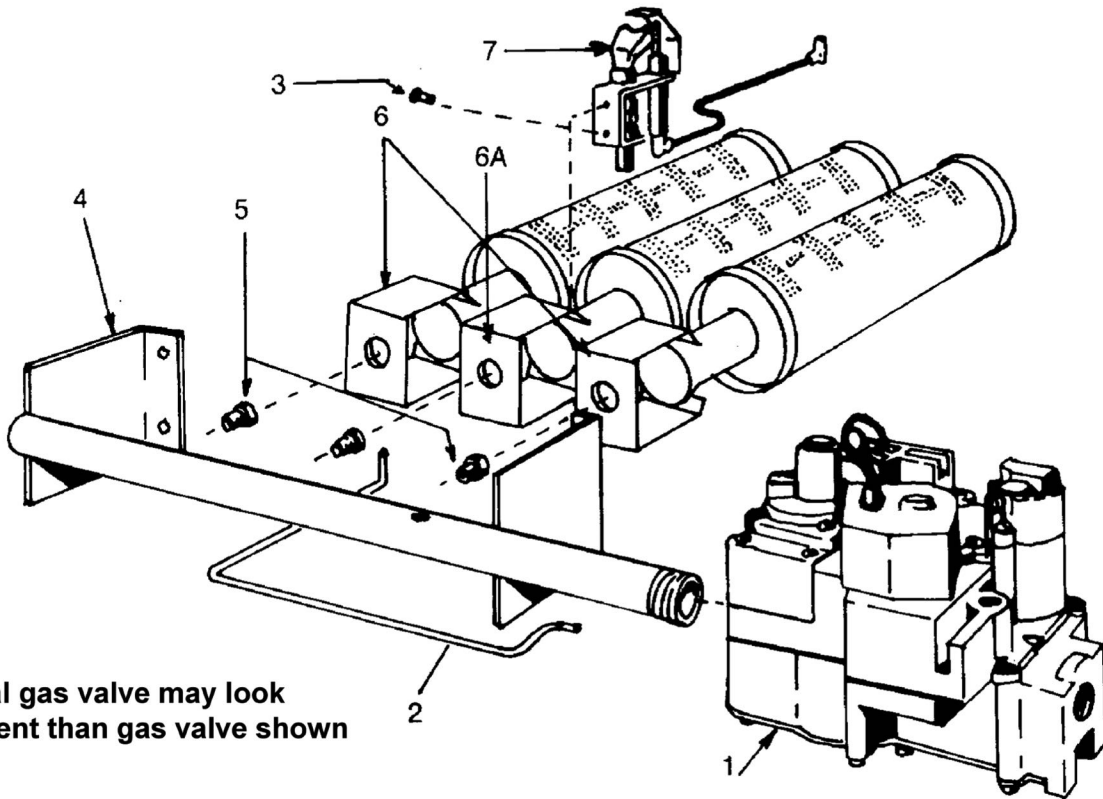

NOTE: Actual gas valve may look different than gas valve shown

PROPANE GAS BURNERS AND MANIFOLD PARTS

THIS IS A REPAIR PARTS LIST - NOT A PACKING LIST

ELECTRONIC INTERMITTENT IGNITION (Shown)

KEY NO.	DESCRIPTION	3 SECTION	4 SECTION	5 SECTION	6 SECTION	7 SECTION	8 SECTION	9 SECTION
		Part No.	Part No.	Part No.	Part No.	Part No.	Part No.	Part No.
1	24 Volt Gas Valve, Elect. Inter. Ignition	146-62-062	146-62-062	146-62-062	146-62-062	146-62-062	146-62-062	146-62-062
2	Pilot Tube	146-15-005	146-15-005	146-15-005	146-15-005	146-15-005	146-15-005	146-15-005
3	10-32 3/16 Hex Hd. Screw	146-95-301	146-95-301	146-95-301	146-95-301	146-95-301	146-95-301	146-95-301
4	Gas Manifold	146-16-010	146-16-011	146-16-012	146-16-013	146-16-014	146-16-015	146-16-016
5	Main Burner Orifice*	146-15-036	146-15-036	146-15-036	146-15-036	146-15-036	146-15-036	146-15-036
6	Main Burner, Regular**	146-15-532	146-15-532	146-15-532	146-15-532	146-15-532	146-15-532	146-15-532
6A	Main Burner, Pilot Mount	146-15-531	146-15-531	146-15-531	146-15-531	146-15-531	146-15-531	146-15-531
7	Pilot Burner	146-62-094	146-62-094	146-62-094	146-62-094	146-62-094	146-62-094	146-62-094
‡	Rollout Shield	425-00-933	425-00-934	425-00-935	425-00-936	425-00-937	425-00-938	425-00-939

ALTERNATE PARTS FOR CONTINUOUS PILOT - 24 VOLT

1	24 Volt Gas Valve, Continuous Pilot	146-62-061	146-62-061	146-62-061	146-62-061	146-62-061	146-62-061	146-62-061
3	10-32 3/16 Hex Hd. Screw (2 req'd)	146-95-301	146-95-301	146-95-301	146-95-301	146-95-301	146-95-301	146-95-301
7	Pilot Burner	146-62-098	146-62-098	146-62-098	146-62-098	146-62-098	146-62-098	146-62-098
‡	Thermocouple	152-00-01	146-62-039	146-62-039	146-62-039	146-62-039	146-62-036	146-62-036

Quantity is 1 unless otherwise noted.

* Requires 1 less than the number of sections.

** Requires 2 less than the number of sections

‡ Not Illustrated

BOILER CONTROLS AND PIPING

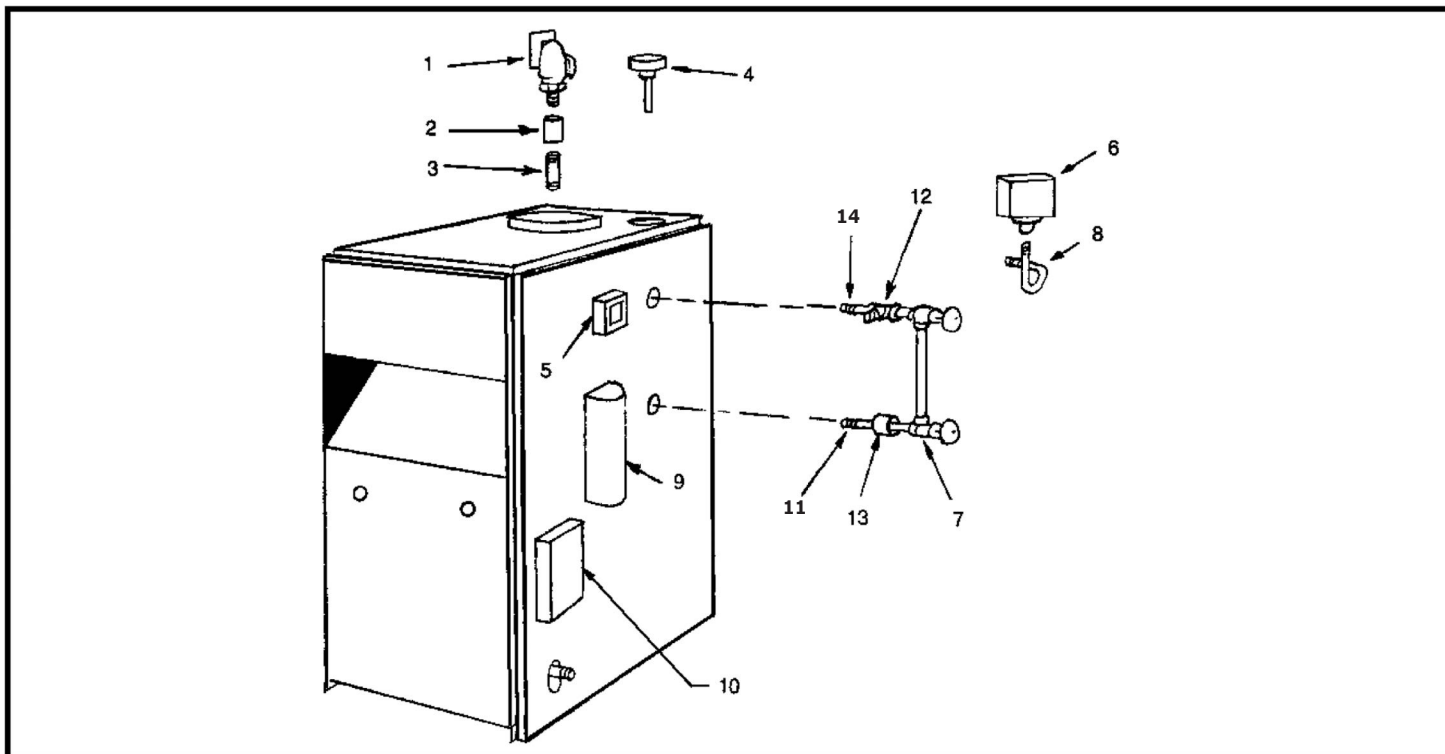

Key No.	Description	Part No.
1	3/4" Safety Relief Valve	157-00-01
2	3/4" Coupling	115-00-01
3	3/4" x 6 1/2" Nipple	146-07-002
4	Steam Pressure Gauge	146-23-005
5	AT-140D Transformer, 24 Volt	146-62-045
6	PA-404A Pressretrol	146-62-015
7	Glass Water Gauge Set (used with PS-802 LWCO)	146-22-005
‡	Glass Water Gauge Set (used with 67D-1 LWCO)	146-22-010
8	90° Pigtail (used with PS-802 LWCO)	146-43-004
‡	180° Pigtail (used with 67D-1 LWCO)	146-43-005
9	PS-802 Low Water Cut-Off	128-00-02
‡	67D-1 Low Water Cut Off	146-26-042
10	Intermittent Pilot Control	146-62-070
11	1/2 NPT X 4" Nipple	PF-033.02
12	1/2" x 1/2" x 1/4" Brass Tee (PS-802 only)	146-93-051
13	1/2" Brass Coupling (PS-802 only)	146-93-052
14	1/2" x 3 1/2" Brass Nipple (PS-802 only)	146-07-024
‡	3/4" Drain Valve	146-22-001
‡	WF-2U-24 Water Feeder (Optional)	163-00-01
‡	Rollout Switch	146-29-002
‡	Spill Switch (36TX16-6282) 280°F	146-60-002
‡	5" Vent Damper (3 Section Boilers)	118-20-05
‡	6" Vent Damper (4, 5 Section Boilers)	118-20-06
‡	7" Vent Damper (6, 7, 8, 9 Section Boilers)	118-20-07
‡	Vent Damper Operator (Motor)	114-00-02
‡	400°F Black Silicone Rubber Adhesive Sealent (10.3 oz. Cartridge)	146-06-020

‡ Not Illustrated



PRODUCT LITERATURE
Lennox Industries Inc.
Dallas, Texas