

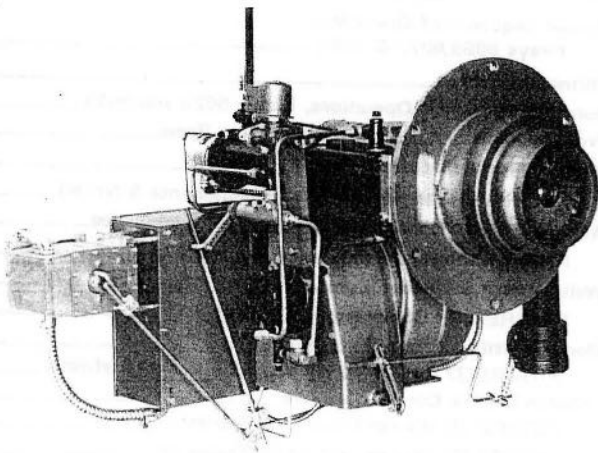

IRON FIREMAN

IRON FIREMAN Forced Draft PAO-PAGO-AGAO-AGO Burners

Installation, Operation and Service Manual



PAGO-4-4.5
ILLUSTRATED

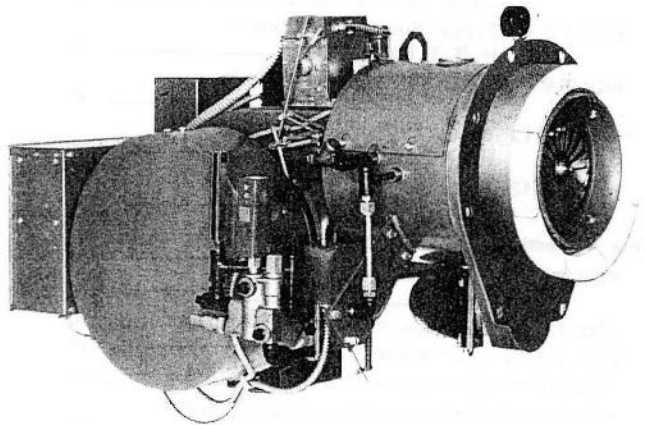

AGO-6-25.5
ILLUSTRATED

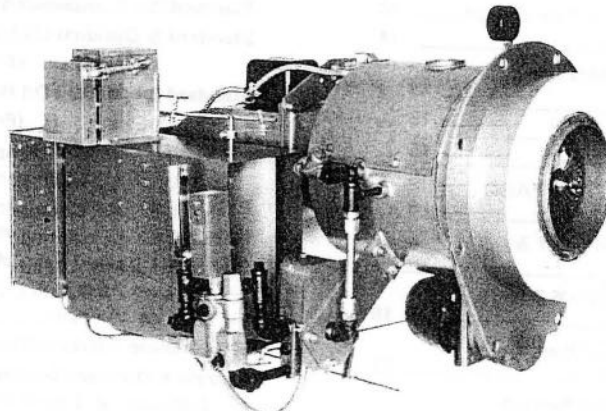

AGO-6-9.8
ILLUSTRATED

INDEX
PAO – PAGO – AG – AO – AGO BURNERS

DESCRIPTION	PAGE	DESCRIPTION	PAGE
General	4	Pre-Start-Up Procedure	18
Loss or damage in transit	4	Start-Up Procedure --- Pressure Atomizing Burners	18
Ventilation and Air Supply	4	Start-Up Procedure --- Gas Burners	20
Model Number Description & Ratings	4	Start-Up Procedure --- Air Atomizing Burners (No. 2 & 4 Oil)	21
Mounting the Burner	4	Start-Up Procedure --- Air Atomizing Burners (No. 5 & No. 6 Oil)	22
Burner Mounting & Mounting Plate	4	Settings and Capacities -- Air Atomizing Burners	23
FIGURE 1 Details for Burner Mounting Plate	5	Oil Nozzle Views	24
FIGURE 2 Details for Burner Mounting Plate	5	FIGURE 27 Pressure Atomizing Return Flow Nozzle	24
Firebox and Combustion Chamber Construction	5	FIGURE 28 Delavan Air Atomizing Nozzle	24
FIGURE 3 Minimum Combustion Chamber for Firebox Boilers	5	FIGURE 29 Monarch Air Atomizing Nozzle	24
FIGURE 4 Minimum Combustion Chamber for Firebox Boilers	5	Linkage (Air Fuel Adjustment)	25
FIGURE 5 Typical Burner Installation in Cast Iron Boiler	6	FIGURE 30 Adjustment PAO-PAGO - 2.1 & 4.5 Burners & AO - 4.5 Burners	25
FIGURE 6 Typical Burner Installation in Cast Iron Boiler	6	FIGURE 31 Adjustment PAO-PAGO- AG-AO-AGO - 6.3 & 9.8 (Gas & No. 2/No. 4 Oil)	26
FIGURE 7 Typical Burner Installation in Firebox Boiler	6	FIGURE 32 Adjustment PAO-PAGO - 15	26
FIGURE 8 Typical Burner Installation in Firebox Boiler	7	FIGURE 33 Adjustment AO & AGO - 6.3 & 9.8 (No. 5 & No. 6 Oil)	27
FIGURE 9 Typical Burner Installation in Scotch Boiler	7	FIGURE 34 Adjustment AO & AG & AGO - 15 & 22.5 & 25.5	27
FIGURE 10 Typical Burner Installation in H. R. T. Boiler	7	Burner Sequence of Operation, Fireye 6058,6070 & 6080	28
FIGURE 11 Typical Burner Installation in Water Tube Boiler	8	Wiring Diagrams	31
FIGURE 12 Typical (2) Burner Installation in Water Tube Boiler	8	Burner Sequence of Operations, Fireye 5023 and 5022	38
FIGURE 13 Furnace Tube Diameter in Scotch Boiler	8	Pressure Atomizing Burner, Nozzle Flow Rates	42
Flue Connections -- Draft and Furnace Pressures	8	Approximate AC Motor Amps	43
FIGURE 14 Gas Pressure Drop thru 2.1 & 4.5 Burners	9	Service Hints (Problems, Remedies, Maintenance & Notes)	44
FIGURE 15 Gas Pressure Drop thru 6.3 Burners	10	Air Compressor, Location, Lubrication & Maintenance	46
FIGURE 16 Gas Pressure Drop thru 9.8 Burners	11	FIGURE 35 Air Compressor (Locating)	46
FIGURE 17 Gas Pressure Drop thru 15 Burners	12	Wells Electric Oil Heaters	47
FIGURE 18 Gas Pressure Drop thru 22.5 & 25.5 Burners	13	FIGURE 36 Wells Electric Oil Preheater	47
Gas Piping	14	General Fittings Co. Oil Heaters	48
Liquid Petroleum (L.P.) Gas Fired Burner	14	FIGURE 37 General Fittings Co. Electric Oil Preheater	48
FIGURE 19 Standard Piping of Gas Pipe Groups	14	Warren Electric Corp Oil Heaters	48
FIGURE 20 Gas Line Dirt Pocket	14	FIGURE 38 Warren Electric Oil Preheater	49
Oil Piping, Oil Tanks & Suction Bell (Hot Well)	15	FIGURE 39 Warren Electric Oil Preheater	49
Suggested Oil Pipe Sizes Near Burner	15	Lectricoil Oil Heater Information	50
Suggested Air Pipe Sizes	15	FIGURE 40 Lectricoil Viscosity -- Temperature Chart	51
PAO-PAGO Burner Oil Pump Adjustment	15	Standard Air Compressor & Oil Pump Assembly Part Numbers	52
FIGURE 21 A & B Fuel Oil Pump PAO-PAGO Burners	15	Standard & Optional Oil Heater Element Part Numbers (Air Atom.)	52
FIGURE 22 Oil piping PAO-PAGO - 2.1 & 4.5 Burners	16	Standard & Optional Oil Heater Element Part Numbers (Press. Atom.)	52
FIGURE 23 Oil Piping PAO-PAGO - 6.3 & 9.8 & 15 Burners	16	FIGURE 41 Air Compressor/Pump Parts List	53
FIGURE 24 Oil Piping AO & AGO Burners (No. 2 & No. 4 Oil)	17	FIGURE 42 Circulating Valve Assembly Parts List	54
FIGURE 25 Oil piping AO & AGO Burners (No. 5 & No. 6 oil)	17	FIGURE 43 Mech. Modulating Oil Valve Assembly Parts List	54
FIGURE 26 Oil Piping -- Duplex Pump & Circulation Loop	18	FIGURE 44 Oil Relief Valve Assembly Parts List	54
		FIGURE 45 Electric Hi-Lo (Mag. Mod) Valve Parts List	55
		Oil Solenoid Valves -- Standard	55
		Nozzle & Diffuser Settings	56
		FIGURE 46 PAO-PAGO - 2.1 & 4.5 Burners	56
		FIGURE 47 PAO-PAGO - 6.3 & 9.8 Burners	56
		FIGURE 48 PAO-PAGO - 15 Burners	56

INDEX (Continued)
PAO – PAGO – AG – AO – AGO BURNERS

DESCRIPTION	PAGE	DESCRIPTION	PAGE
FIGURE 49 AO - 4.5 Burners	56	Parts and Part Number References & Figures	
FIGURE 50 AO & AGO – 6.3 & 9.8 Burners	57	FIGURE 65 Control Panel (Cabinet)	64
FIGURE 51 AO & AGO - 15 Burners	57	FIGURE 66 PAO-PAGO 2.1 or 4.5 (No. 2 or 4 Oil)	66
FIGURE 52 AO - AGO 22.5 & 25.5 Burners	57	FIGURE 67 PAO - PAGO 2.1 or 4.5 (No. 2 or No. 4 Oil)	66
FIGURE 53 Oil Pump Parts List – PAO & PAGO	58	FIGURE 68 AO - 4.5 (No. 2 or No. 4 Oil)	67
FIGURE 54 Oil Pump Parts List – AO - AGO, No. 6 Oil	59	FIGURE 69 AO - 4.5 (No. 2 or No. 4 Oil)	67
Oil Gun & Pilot Assemblies – Parts Lists For Burners		FIGURE 70 AO - 6 - 4.5 (No. 6 Oil)	68
FIGURE 55 PAO - 2.1 & 4.5 (Pilot & Gun)	60	FIGURE 71 AO - 6 - 4.5 (No. 6 Oil)	68
FIGURE 56 PAGO - 2.1 & 4.5 (Pilot & Gun)	60	FIGURE 72 PAO - PAGO - 6.3 or 9.8 (No. 2 or No. 4 Oil)	69
FIGURE 57 AO - 4.5 (Pilot & Gun)	61	FIGURE 73 PAGO, AG or AGO - 6.3 or 9.8 (No. 2 or No. 4 Oil)	69
FIGURE 58 PAO - 6.3 & 9.8 (Pilot & Gun)	61	FIGURE 74 AO - AGO - 6.3 or 9.8 (No. 2 or No. 4 Oil)	70
FIGURE 59 AO - 6.3 & 9.8 (Pilot & Gun)	62	FIGURE 75 AO - AGO - 6.3 or 9.8 (No. 6 Oil)	70
FIGURE 60 AO – PAO - 6.3 & 9.8 (Pilot)	62	FIGURE 76 PAO - PAGO - 15 (No. 2 or No. 4 Oil)	71
FIGURE 61 PAGO - 6.3 & 9.8 & 15; PAO-15; AG & AGO - 6.3 & 9.8; AG & AO & AGO - 15 & 22.5 & 25.5 (Pilot)	62	FIGURE 77 PAGO, AG, AGO - 15, 22.5 or 25.5 (No. 2 or No. 4 Oil)	71
FIGURE 62 PAO - 15; PAGO - 6.3 & 9.8 & 15 (Gun)	63	FIGURE 78 AO - AGO - 15, 22.5 or 25.5 (No. 2 or No. 4 Oil)	72
FIGURE 63 AGO - 6.3 & 9.8; AO & AGO - 15 22.5 & 25.5 (Gun)	63	FIGURE 79 AO - AGO 15, 22.5 or 25.5 (No. 6 Oil)	72
FIGURE 64 Oil Strainers – Parts List.	63		

SPECIFICATIONS SUBJECT TO CHANGE WITHOUT NOTICE.

GENERAL

The information on the following pages has been prepared to make it possible to properly install the burner and insure continuous trouble-free operation.

At the factory, the burner was carefully built, tested, checked and crated. To insure long burner life and highest efficiency and safety, only qualified persons should attempt to install, service and maintain the burner.

Burners mentioned herein are built to UL standards. Local codes or insurance approval agencies may specify controls other than those furnished as standard with the burner. Also, these requirements may call for additional controls, etc. These requirements should be determined and complied with on each installation.

LOSS OR DAMAGE IN TRANSIT

Upon receipt of the burner, all cartons should have been inspected for damage by the consignee. The cartons should have been opened and inspected for damage. If loss or damage was visible, the delivering carrier's waybill should have been noted accordingly and carrier's inspector should have been consulted.

Any damaged cartons or equipment should be kept until carrier's inspector has had the opportunity to judge the cause of damage.

Concealed damage claims should normally be filed with delivering carrier within five days after receipt of equipment.

All equipment is sold FOB factory or original shipping point. It is the responsibility of the consignee to fill claims with delivery carrier for materials received in a damaged condition.

VENTILATION AND AIR SUPPLY

Air is consumed in large quantities when fuel is burned, approximately 2,250 cubic feet for each gallon of oil, and 15,000 cubic feet for each 1,000 cubic feet of natural gas. Either openings in the walls or ducts must be provided through which the air can enter the boiler room from outdoors. Usually the air that enters to replace that used in burning the fuel will provide ventilation enough to keep the boiler room from becoming excessively hot. When this is not the case, additional openings must be provided. Local building codes and fire codes should be consulted for their requirements, and also the regulations of the company that carries the insurance on the building. When there are no local or insurance regulations, a rule of thumb that will normally supply sufficient air for both combustion and ventilation is to allow one square inch of free opening for each 10,000 Btu of fuel input per hour. When other devices such as exhaust fans, vent ducts, air compressors, etc., are used in the boiler room, air requirements for these must also be considered.

MODEL NUMBER DESCRIPTION

The burners' model number describes the type of burner, fuel(s) it will burn, and the normal maximum firing rate in MBH.

Model Type Designation

PA = Pressure Atomizing	2.1 = Burner Size Rate 2100 MBH
A = Air Atomizing	*4.5 = Burner Size Rate *4200 MBH
O = Oil Firing	6.3 = Burner Size Rate 6300 MBH
G = Gas Firing	9.8 = Burner Size Rate 9800 MBH
2 = No. 2 Oil	15 = Burner Size Rate 15000 MBH
4 = No. 4 Oil	22.5 = Burner Size Rate 22500 MBH
6 = No. 5 or 6 Oil	25.5 = Burner Size Rate 25000 MBH

EXAMPLE: A PAGO-4-6.3 designation would indicate a Pressure Atomizing Gas and Oil Firing Burner, equipped to burn No. 4 fuel and gas at a rating of 6300 MBH.

*Except for the 4.5, the suffix numbers = the burners normal maximum firing rate in MBH. Example: 6.3 = 6300 MBH maximum firing rate. (The normal maximum firing rate of the 4.5 = 4200 MBH).

Note: Certain types of boilers that cannot be sealed tightly and must operate exclusively with a negative draft, may require that

the burner used be modified by reducing the fan capacity - through the use of other than standard size motor and fan. Such burners will normally be defined by the suffix "L" at the end of the burner model number, stamped on the burner.

Note: With Iron Fireman's own packaged boilers, the specific burners used on the boilers may be further modified for higher actual capacity.

RATINGS & CAPACITIES (NORMAL MAXIMUMS*)

BURNER SIZE	GAS	OIL
	MBH	GPH
2.1	2100	15
4.5	4200	30
6.3	6300	45
9.8	9800	70
15	15000	100
22.5	22500	150
25.5	25500	180

* FOR EXACT FIRING RATE, REFER TO COPY OF ORDER IN BURNERS' CONTROL CABINET.

MOUNTING THE BURNER

The burner is equipped with an integral mounting flange that is normally capable of supporting the entire weight of the burner when attached to a suitable burner mounting plate on the boiler. Holes are provided in the flange for bolting the burner to the mounting plate. Additional support may be placed under the burner by bolting a 2" iron pipe floor flange under the burner; a pad is provided at the bottom of the burner drilled to match the floor flange and 2" pipe.

Boiler front drillings to suit burner mounting flange are illustrated in Figures 1 and 2.

A seal formed of asbestos rope must be placed between the burner mounting flange and the boiler front to prevent the escape of combustion gases from the furnace area of the boiler. Take particular care around the bolt holes to prevent leakage at these points.

BURNER MOUNTING & MOUNTING PLATE

A 3/8" steel plate must be used to mount the burner to the boiler. The exact dimensions are shown in Figures 1 and 2. (A heavier or lighter weight plate may be used, depending on reinforcement and other types of support used or preferred).

The mounting plate, burner and the front end of the boiler must be protected by insulation or refractory ahead of the mounting plate. See Figures 3 thru 13 for typical illustrations.

Note No. 1: The figures illustrating typical burner mounting in various types of boilers in this manual are for reference only. Due to the many, many types of boilers and designs, it is not possible to list exact dimensions for your particular application. Consult factory for specific assistance. Iron Fireman does not accept any responsibility for misapplication or questionable applications.

Note No. 2: When selecting the burner mounting location, special attention must be given to how the burners' flame detector (scanner) will see the fire. The detector should not be allowed to sight directly at hot, bright brickwork or refractory; when such a condition exists, Iron Fireman does not accept the responsibility for the costs incurred to modify the brickwork or refractory or modifying the location of the flame detector. (For additional data, refer to Flame Safeguard and Programming Literature).

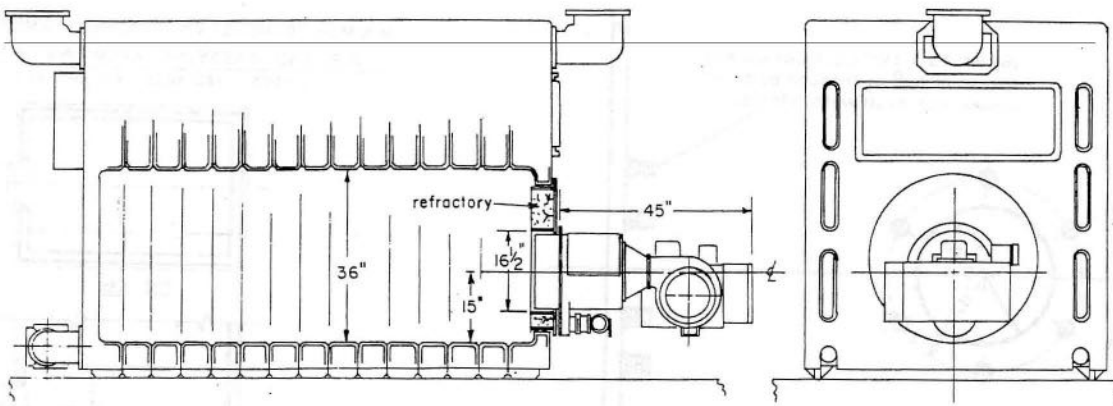

TYPICAL
CAST IRON SECTIONAL BOILER
 (WET BASE TYPE)

PAGO-2-6.3 BURNER

FIGURE 5

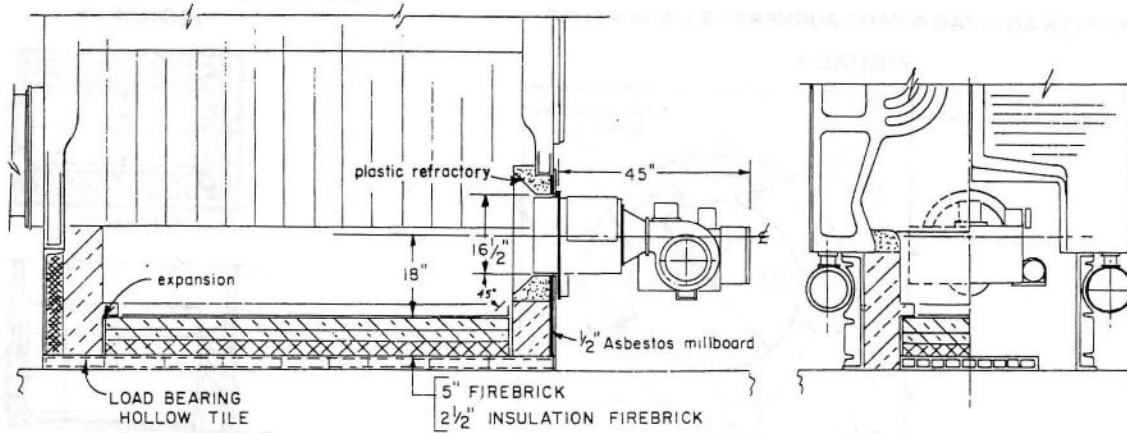

CAST IRON SECTIONAL BOILER - TYPICAL
 (OPEN FRONT TYPE)

AO-4-9.8 BURNER

FIGURE 6

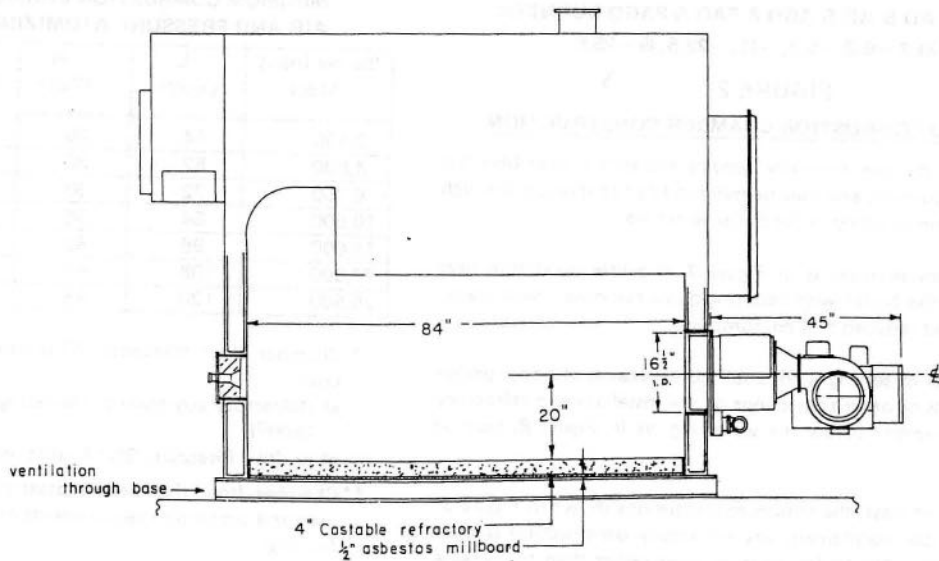

STEEL FIREBOX BOILER - TYPICAL

AGO-2-9.8 BURNER THROUGH WATER SECTION

FIGURE 7

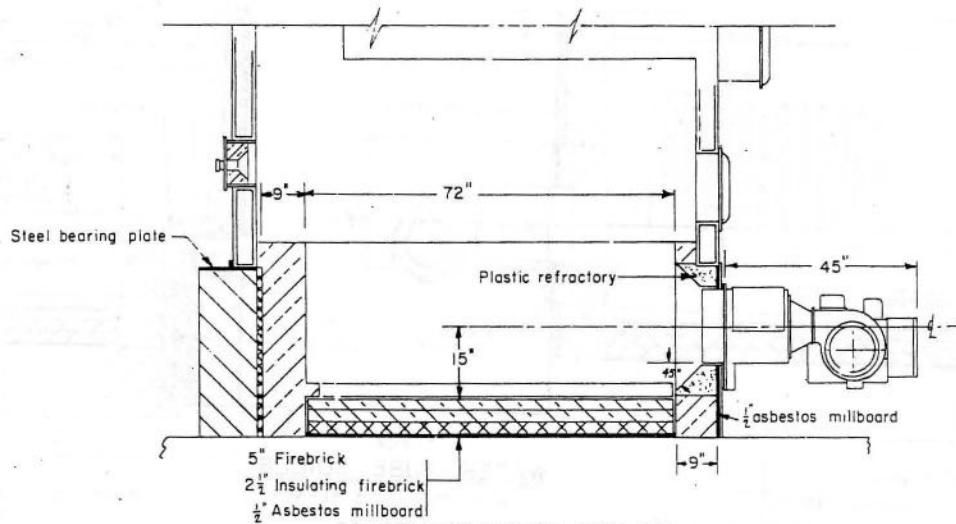

STEEL FIREBOX BOILER - TYPICAL
 AGO-4-6.3 BURNER FIRED INTO REFRACTORY CHAMBER
 UNDER WATER SECTION

FIGURE 8

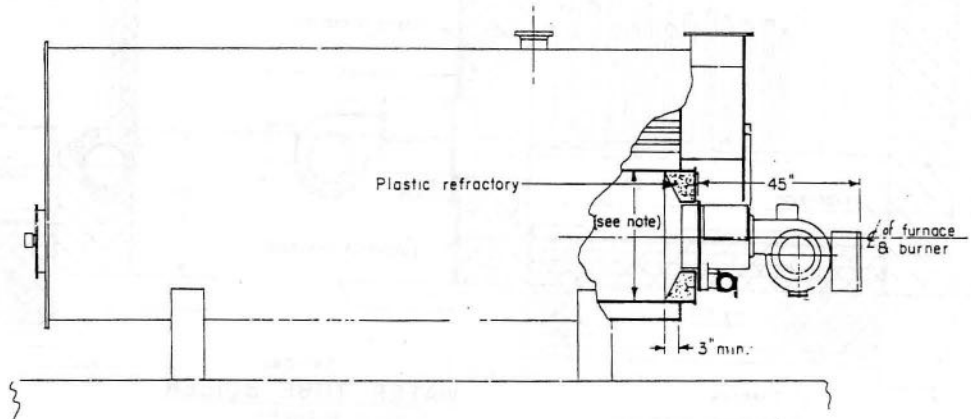

**TYPICAL
 SCOTCH BOILER**

FIGURE 9

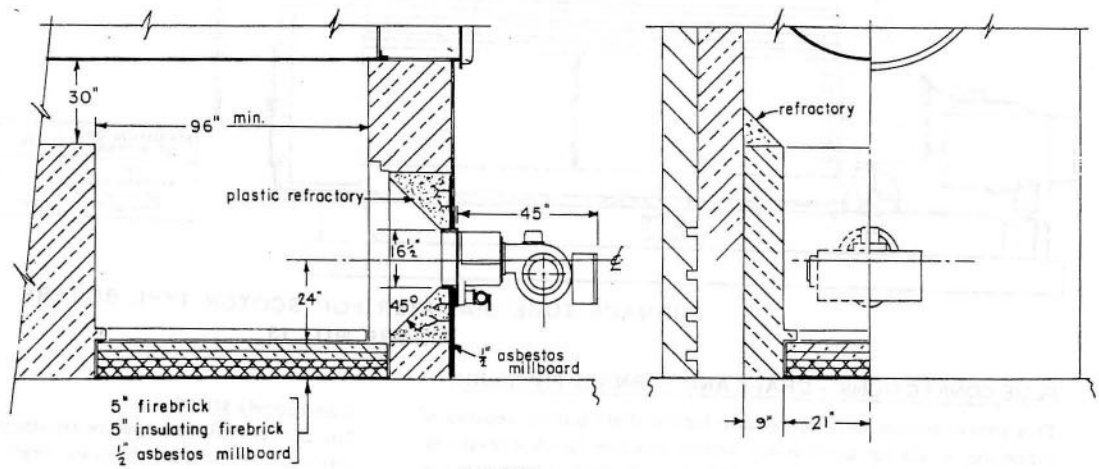

**TYPICAL
 H.R.T. BOILER**

**AGO-15 BURNER
 FIGURE 10**

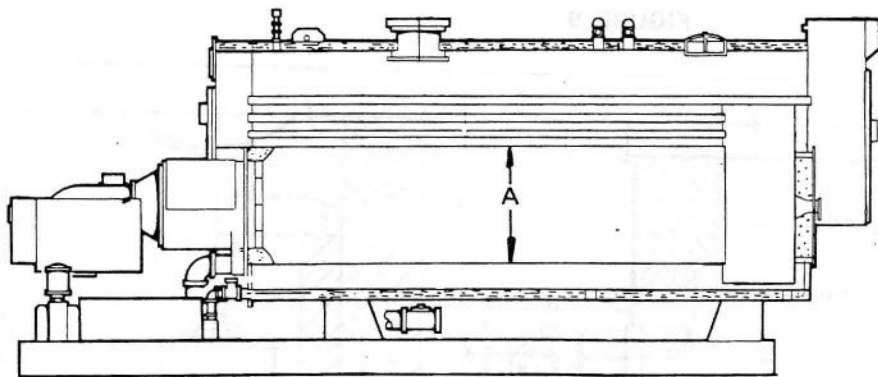
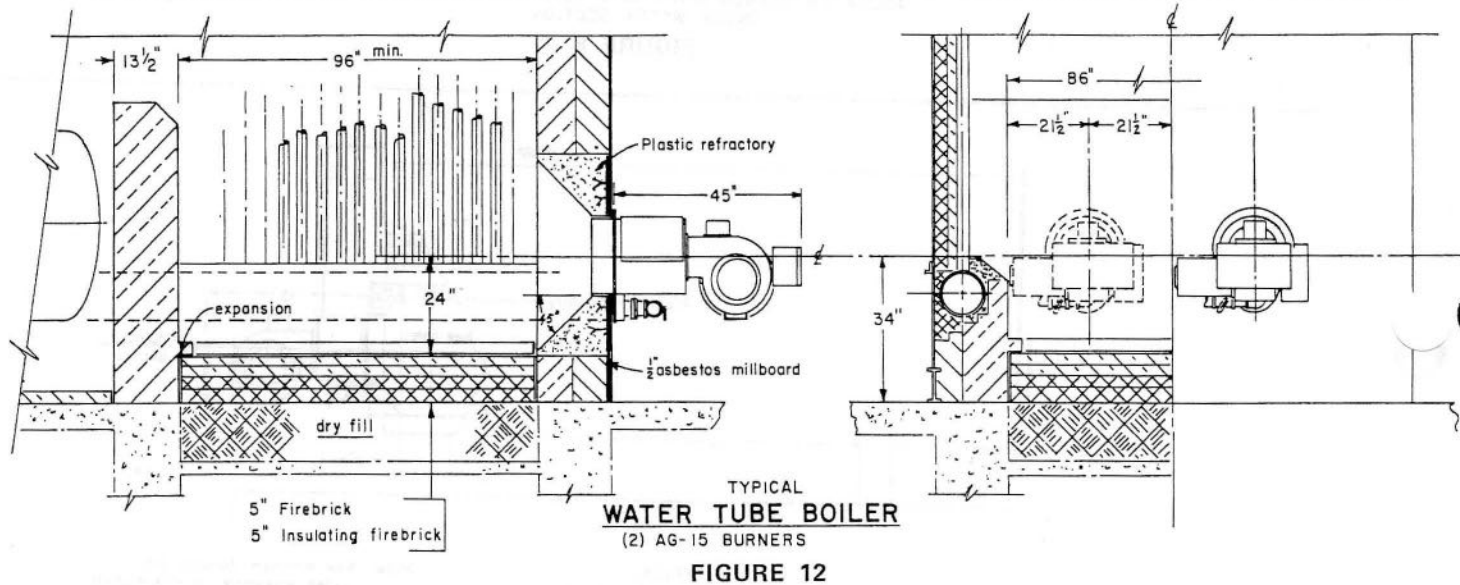
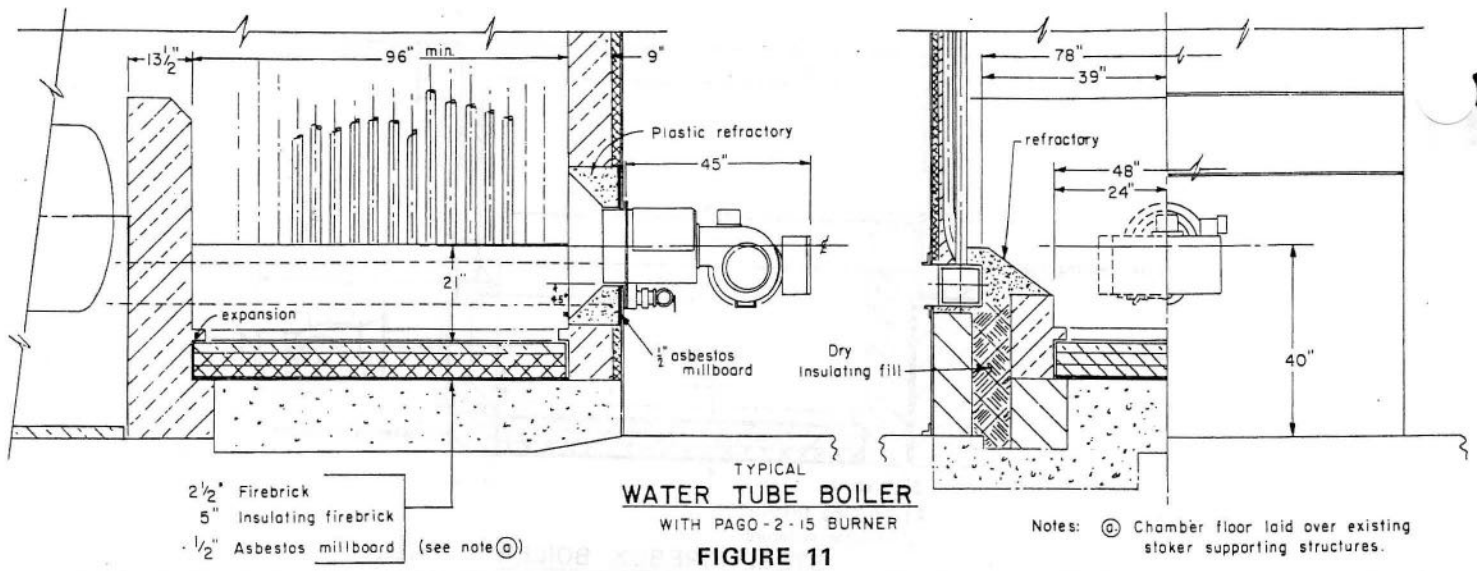

MAXIMUM GPH OF BURNER	30	45	70	100	150
"A" Recommended Minimum Dimension	24"	26"	30"	36"	42"

FURNACE TUBE DIAMETER FOR SCOTCH TYPE BOILERS
FIGURE NO. 13

FLUE CONNECTIONS – DRAFT AND FURNACE PRESSURE

This model burner is designed as a forced draft burner capable of supplying all air for combustion against positive furnace pressures. This means it will handle boilers with a stub stack where negative draft is not available. See Burner "Gas Pressure Drop Across Burner Head" chart for maximum furnace pressures and firing rates. Furnace pressures cannot be positive (plus) unless combustion chamber

is adequately sealed.

The burner will also operate satisfactorily with conventional stacks and negative furnace pressures. Draft regulators are not required on many installations, but with relatively high chimneys, particularly with multiple burners on the same flue, draft regulators may be needed. Consult local codes for regulations.

GAS PRESSURE DROP ACROSS BURNER HEAD

PAGO 2.1 & 4.5

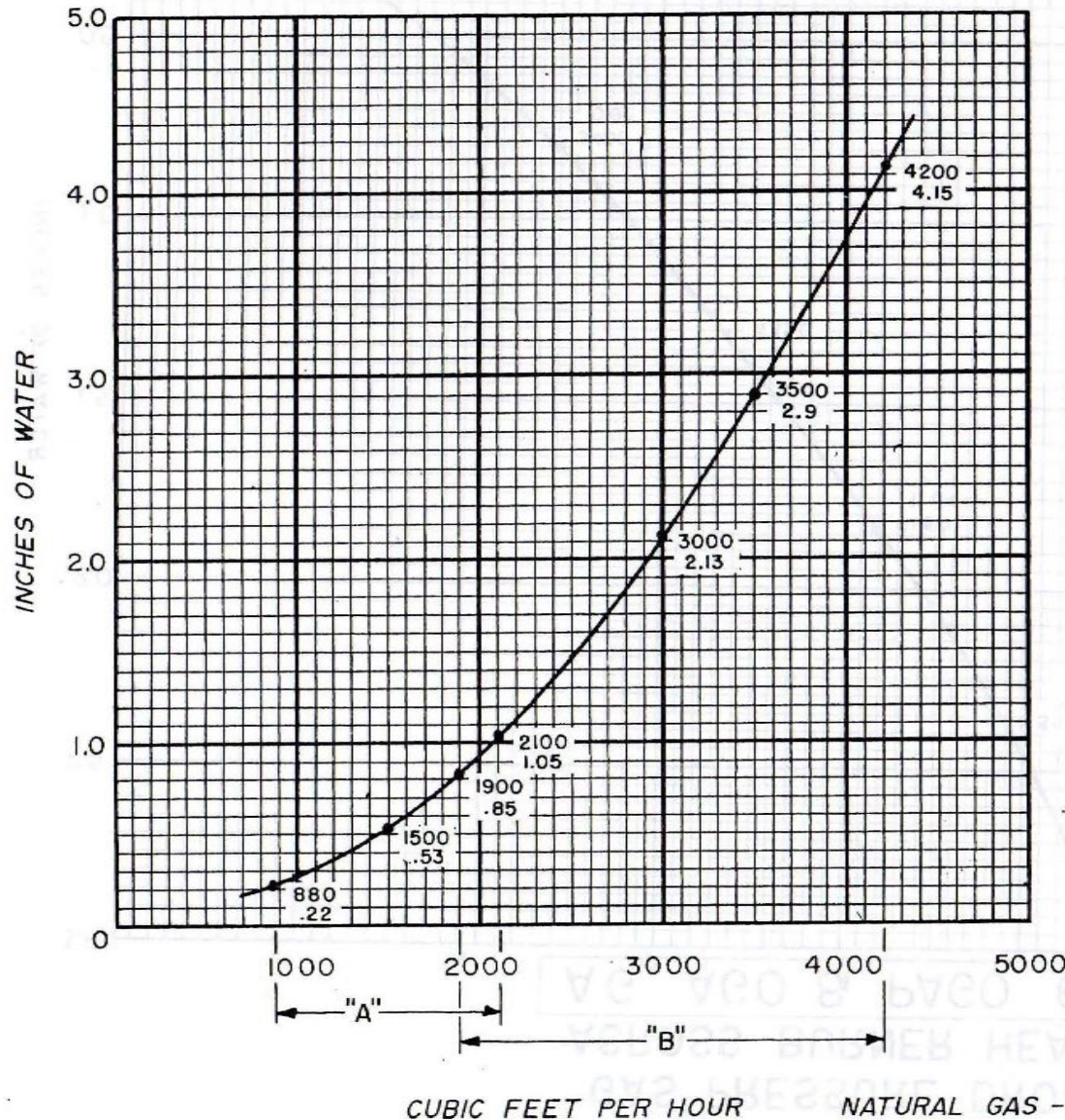

LOSS THROUGH STANDARD 2 1/2" BUTTERFLY VALVE AT 4200 CFH --.18" w.c.

GAS JETS: 16--.332 DIA.
(1) 1 1/8" PIPE ON CENTER
GAS CAN FULL OPEN

NOTICE:

To arrive at total gas pressure required--the sum of the following must be considered:

1. Pressure drop thru gas train.
2. Pressure drop thru butterfly valve.
3. Pressure drop across burner head.
4. Boiler's furnace pressure. (Maximum of 1" w.c. at Maximum Firing Rate.)

"A"--PAGO-2.1 Burner with 7" Choke Ring
"B"--PAGO-4.5 Burner with 7" Choke Ring

CUBIC FEET PER HOUR NATURAL GAS - 1000 BTU/CU.FT., .60 SP. GR.

FIGURE 14

GAS PRESSURE DROP ACROSS BURNER HEAD AG, AGO & PAGO 6.3

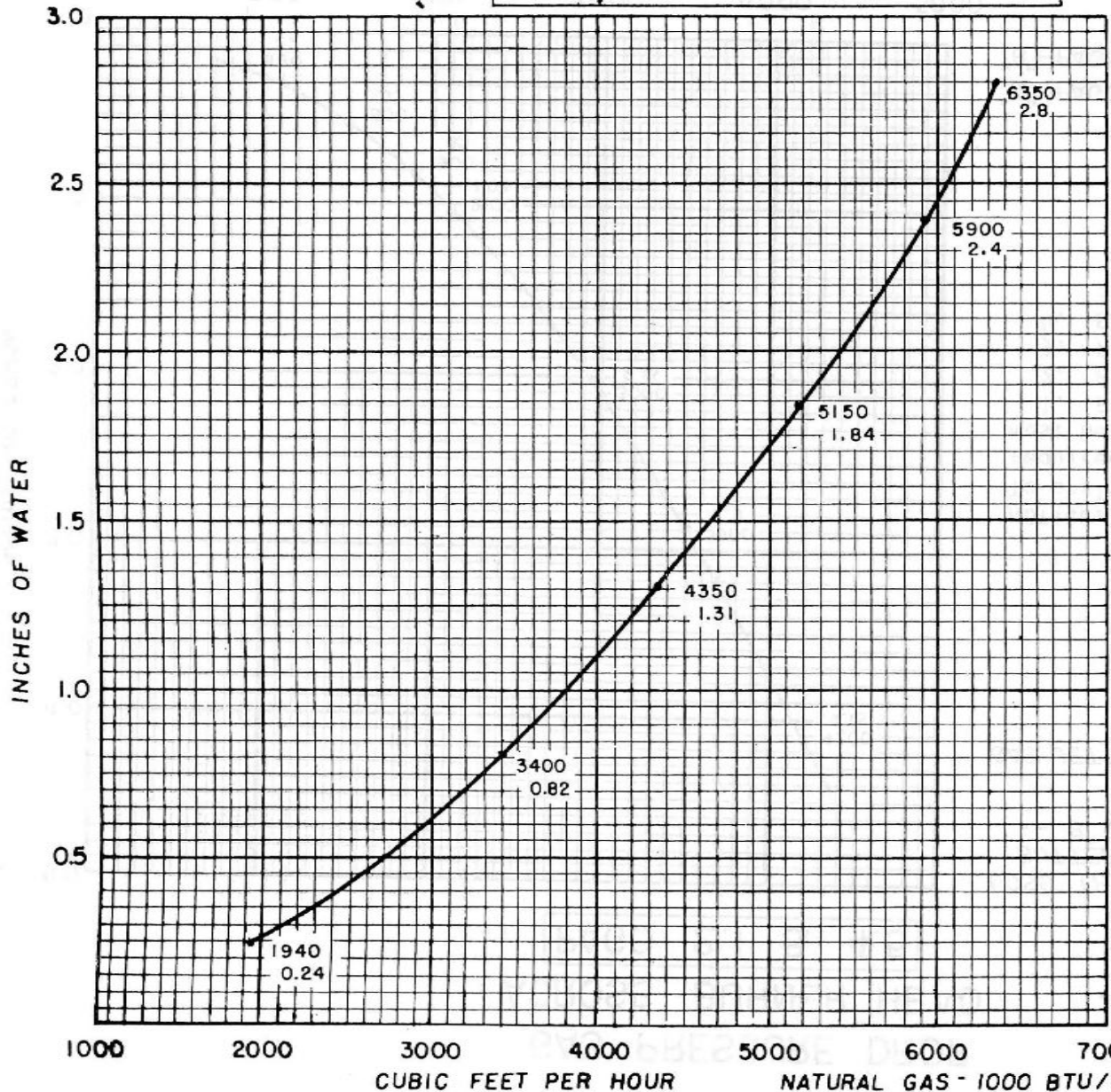

GAS GAP BETWEEN OUTER RINGS - .046
TWO 1/8" CENTER PIPES - FULL OPEN
LOSS THROUGH STD. 2 1/2" BUTTERFLY
VALVE AT 6300 CFH 0.4" w.c.

- NOTICE:**
To arrive at total gas pressure required--the sum of the following must be considered:
1. Pressure drop thru gas train.
 2. Pressure drop thru butterfly valve.
 3. Pressure drop across burner head.
 4. Boiler's furnace pressure. (Maximum of 2" w.c. @ Maximum Firing Rate).

GAS PRESSURE DROP ACROSS BURNER HEAD

AG, AGO & PAGO 9.8

GAS GAP BETWEEN OUTER RINGS - .063
TWO 1 1/8" CENTER PIPES - FULL OPEN
LOSS THROUGH STD. 3" BUTTERFLY
VALVE AT 9800 CFH 0.13" w.c.

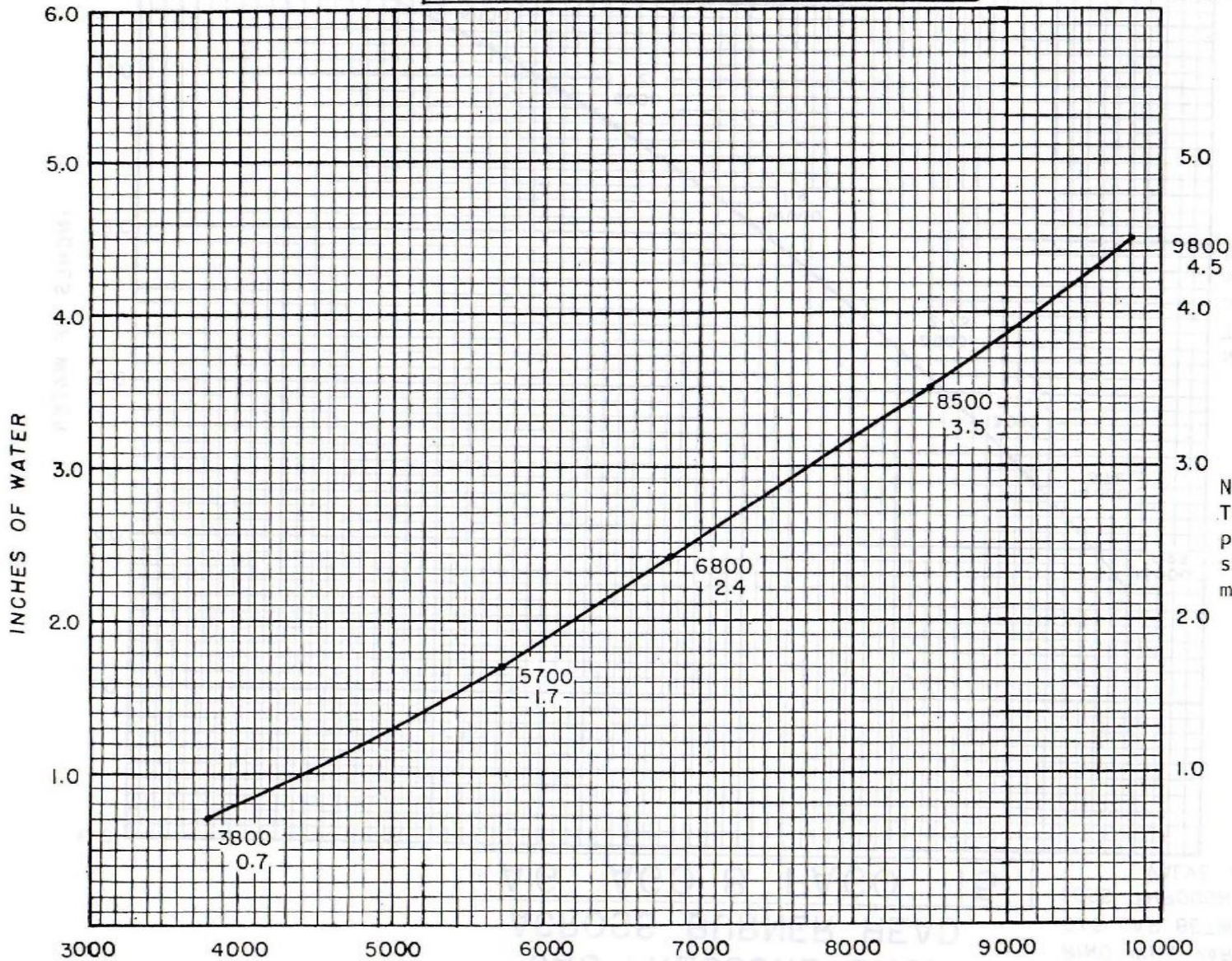

CUBIC FEET PER HOUR

NATURAL GAS - 1000 BTU/CU.FT., .60 SP. GR.

FIGURE 16

NOTICE:

To arrive at total gas pressure required--the sum of the following must be considered:

1. Pressure drop thru gas train.
2. Pressure drop thru butterfly valve.
3. Pressure drop across burner head
4. Boiler's furnace pressure (Maximum of 2" w.c. @ Maximum Firing Rate).

GAS PRESSURE DROP ACROSS BURNER HEAD

AG, AGO & PAGO 15

ADJUSTMENT OF INTERNAL RESTRICTOR RING WILL VARY THE INDICATED PRESSURES
GAS GAP BETWEEN OUTER RINGS - .125
LOSS THROUGH STD. 4" BUTTERFLY VALVE AT 15,000 CFH 0.15" w.c.

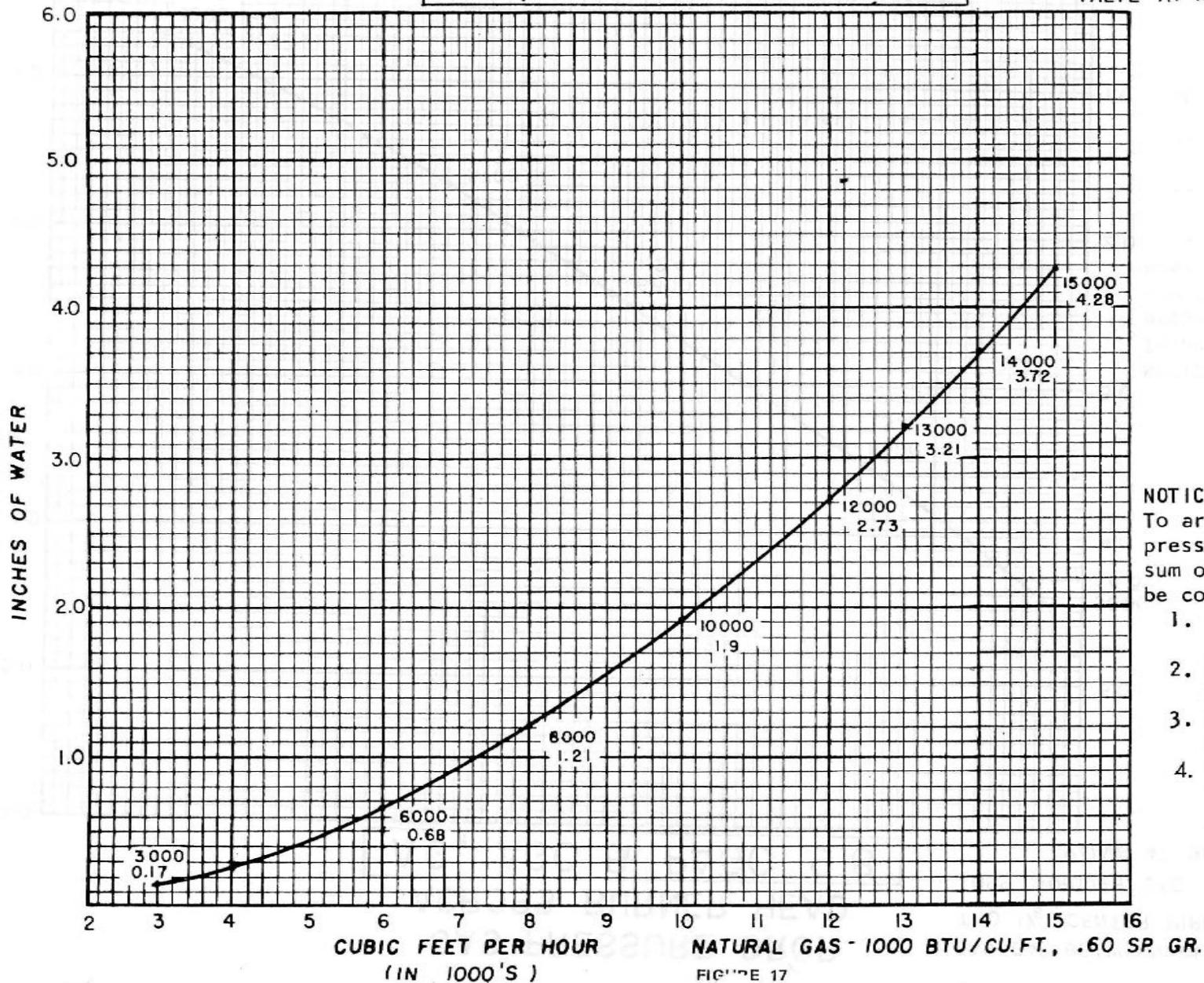

NOTICE:

To arrive at total gas pressure required--the sum of the following must be considered:

1. Pressure drop thru gas train.
2. Pressure drop thru butterfly valve.
3. Pressure drop across burner head.
4. Boiler's furnace pressure. (Maximum of 3" w.c. @ Maximum Firing Rate).

FIGURE 17

GAS PRESSURE DROP ACROSS BURNER HEAD

AG & AGO-22.5 & 25.5

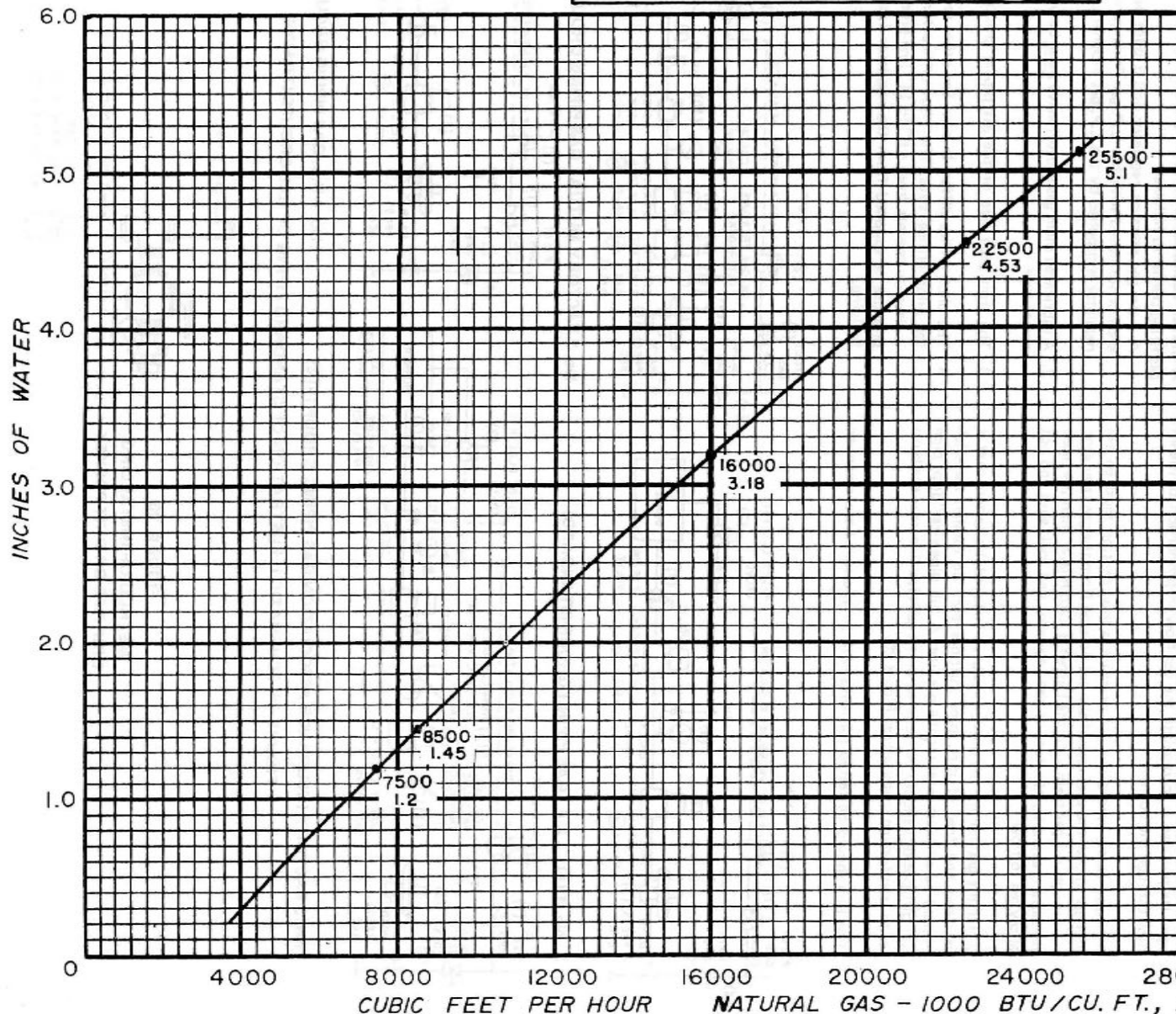

LOSS THROUGH STANDARD 4" BUTTERFLY VALVE AT 22,500 CFH -- .25" w.c.

GAS JETS: 60 HOLES -- .453 DIA.
(4) 1 1/8" PIPES ON CENTER GAS CAN FULL OPEN

- NOTICE:
- To arrive at total gas pressure required--the sum of the following must be considered:
1. Pressure drop thru gas train
 2. Pressure drop thru butterfly valve.
 3. Pressure drop across burner head.
 4. Boiler's furnace pressure. (Maximum 3" of w.c. at Maximum Firing Rate.)

CUBIC FEET PER HOUR NATURAL GAS - 1000 BTU/CU. FT., .60 SP. GR.

FIGURE 18

GAS PIPING

Standard gas piping groups are completely piped at the factory. The gas pipe group shipped with the burner has been sized to suit the particular gas conditions mentioned on the order. A copy of the order and specific gas control literature are included with the burner; Refer to same and also to "Pre-Start-Up Procedure" before attempting to light the burner.

Normally, the pipe group is arranged to suit a particular code or insurance regulation — such as Underwriters Laboratories, Inc., Factory Mutuals or Factory Insurance Associations, See Figure 19. Standard mounting location is at the left side of the burner.

A firing valve is a part of modulating type burners. This is a butterfly type valve connected to a positioning type motor through linkages. Its purpose is to regulate the gas flow in proportion to the air flow through the burner.

In those cases, where the gas pressure is low, caution must be exercised so that the pressure of the gas flowing from the gas regulator — through the gas train — to the burner is kept higher than the back pressure created by the fan; or the regulator will lock shut and not allow gas to flow.

After the gas line for the burner has been installed, be certain that it is clean and free of dirt, pipe cuttings etc. No foreign material should be allowed to enter the gas line. A full pipe size "drip" pipe (or dirt pocket) should be installed in the gas pipe line near the burner to trap foreign material; see Figure 20.

Gas line should be tested for leaks with air pressure before connect-

ing to main gas supply or to the gas piping group furnished with the burner.

Arrange the piping at the burner so that the burner can be removed for inspection without interference with gas piping.

Gas piping should be made to highest standards of materials and workmanship in accordance with local codes, materials and workmanship in accordance with local codes, ordinances and insurances. Where codes do not exist, piping should be in accordance with "American Standard Requirements of Installation of Gas Equipment in Large Boilers" (A.S.A. Z21.33).

LIQUID PETROLEUM (L.P.) GAS FIRED BURNERS

A burner equipped to fire L.P. gas differs from a standard natural gas firing burner as follows:

1. A main gas pressure regulator and a pilot gas pressure regulator are not furnished with the L.P. gas firing burner. (A gas pressure regulator is supplied by the L.P. gas supplier).
2. A lubricated main gas shutoff valve must be used. Pilot valve does not change.
3. The iron pipe size of the gas piping group is usually smaller.
4. The pilot orifice differs in size. See other section in this manual for pilot orifice sizes. The pilot orifice furnished for L.P. gas is sized to operate from a 6" to 11" line pressure. Normally, 11" pressure is supplied from the regulator located outside of the building.

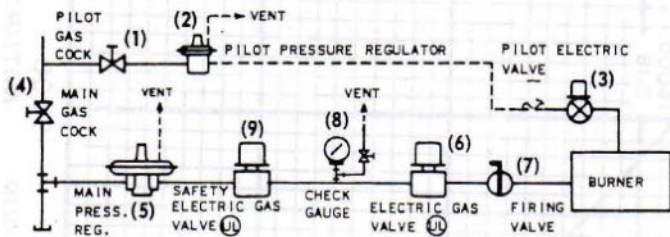

No. 1 U.L. - I. F. GAS PIPING GROUP (STANDARD)

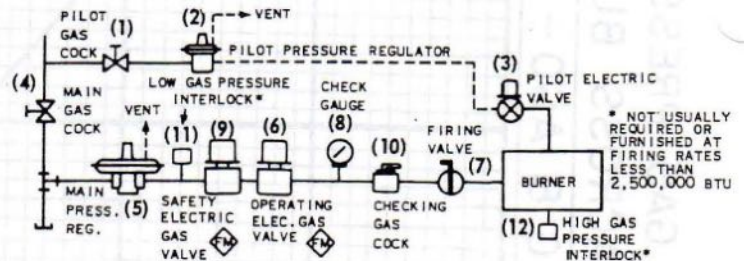

No. 2 FACTORY MUTUAL GAS PIPING GROUP (FM)

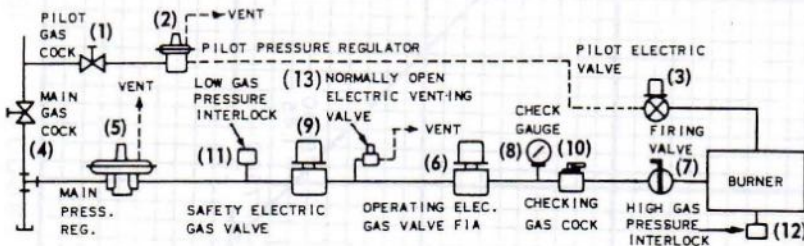

No. 3 FACTORY INSURANCE ASSOCIATION GAS PIPING GROUP (FIA)

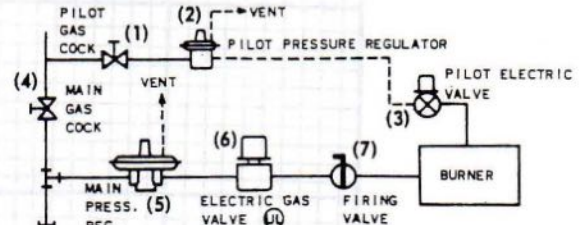

No. 4 U.L. GAS PIPING GROUP (OPTIONAL)

FIGURE 19 SCHEMATIC ILLUSTRATION OF STANDARD PIPING OF GAS GROUPS (TRAINS)

FIGURE 20
METHOD OF INSTALLING
DRIP PIPE OR DIRT POCKET

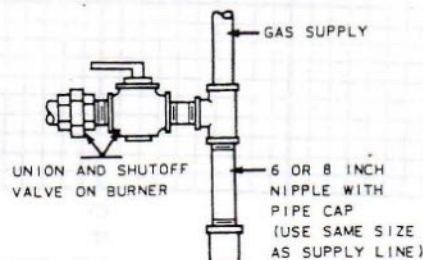

OIL PIPING, OIL & SUCTION BELL

This manual covers the specific piping arrangements for standard burners. The drawings contained herein should be consulted. These drawings do not indicate the systems pipe sizes; pipe sizing and types should be done in accordance with approved industry practice for the specific type of fuel used. For general information

relating to oil storage tanks, piping, sizing and assistance, request an APPLICATION DATA BOOK from your IRON FIREMAN DEALER OR SALESMAN.

The burner should be installed in accordance with the standards of the National Board of Fire Underwriters Pamphlet No. 31, all local codes and/or requirements of the building insurers.

SUGGESTED PIPE SIZES FOR PIPING NEAR THE BURNER (MAXIMUM 10 FEET)

OIL	FIRING RATE	STRAINER TO PUMP	PUMP TO BURNER	RETURN IF CONNECTED
NO. 2 OR NO. 4	To 40 GPH 41— 99 GPH 100—200 GPH	3/8" O. D. Tube or 1/2" Pipe 3/8" O. D. Tube or 3/4" Pipe 3/8" O. D. Tube or 3/4" Pipe	3/8" O. D. Tube—1/2" Pipe 3/8" O. D. Tube—3/4" Pipe 3/8" O. D. Tube—3/4" Pipe	3/8" O. D. Tube 3/8" O. D. Tube 3/8" O. D. Tube, 3/4" Pipe
NO. 5 OR NO. 6	To 40 GPH 41—124 GPH 125—200 GPH	3/8" O. D. Tube or 1" Pipe 1 1/2" Pipe 1 1/2" Pipe	3/8" O. D. Tube—3/4" Pipe 1" Pipe 1 1/4" Pipe	3/4" Pipe 1" Pipe 1 1/4" Pipe

Note: When pipe connections on pumps, or other auxiliaries, are smaller than the pipe size shown, make the reduction as close to the auxiliary as possible.

THE ABOVE IS STRICTLY FOR SHORT RUNS OF NO MORE THAN THOSE ENCOUNTERED ON OR WITHIN ABOUT 10 FT. OF THE BURNER. Long runs should be sized according to approved industry practice.

ATOMIZING AIR CONNECTION (AIR ATOMIZING BURNERS)

BURNER SIZE	PIPE SIZE
- 4.5 & - 6.3	1/2" Iron Pipe or 5/8" O.D. Tubing
- 9.8 & 15.	3/4" Iron Pipe or 7/8" O.D. Tubing
- 22.5 & - 25.5	3/4" Iron Pipe or 7/8" O.D. Tubing

REGULATING OIL PRESSURE ON PAO-PAGO UNITS

To adjust the oil pressure on the FUEL UNIT, rotate the adjusting screw in the pump in a clockwise direction to increase the pressure and counterclockwise to decrease pressure. The standard setting of the pump is 300 pounds.

FIGURE 21A – FUEL OIL UNIT – FOR PAO – PAGO – 2.1 & 4.5 BURNERS

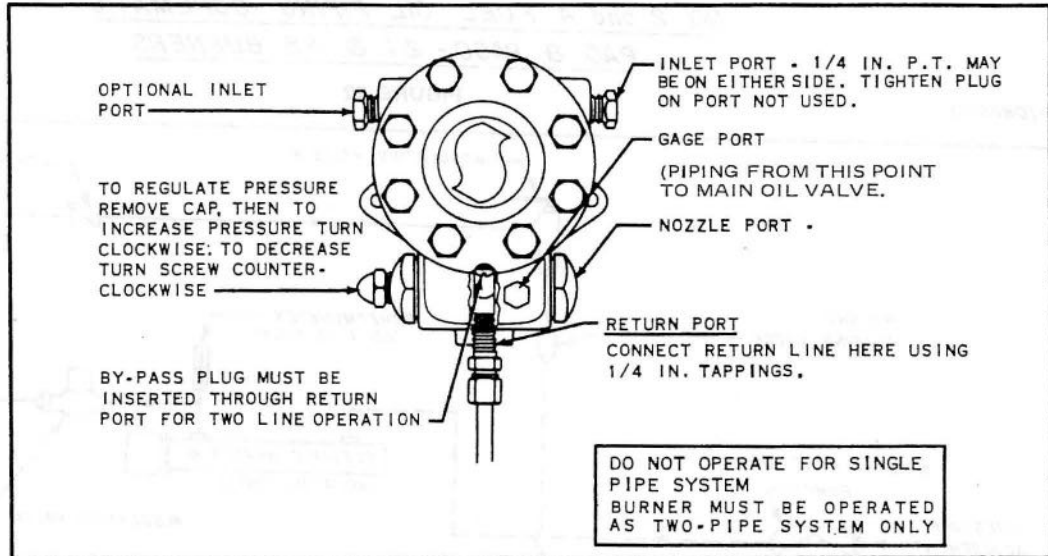
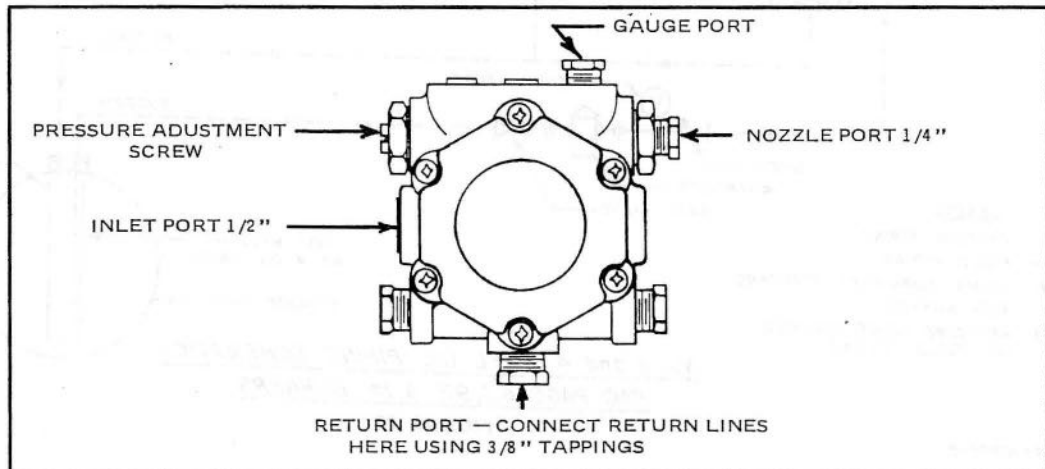
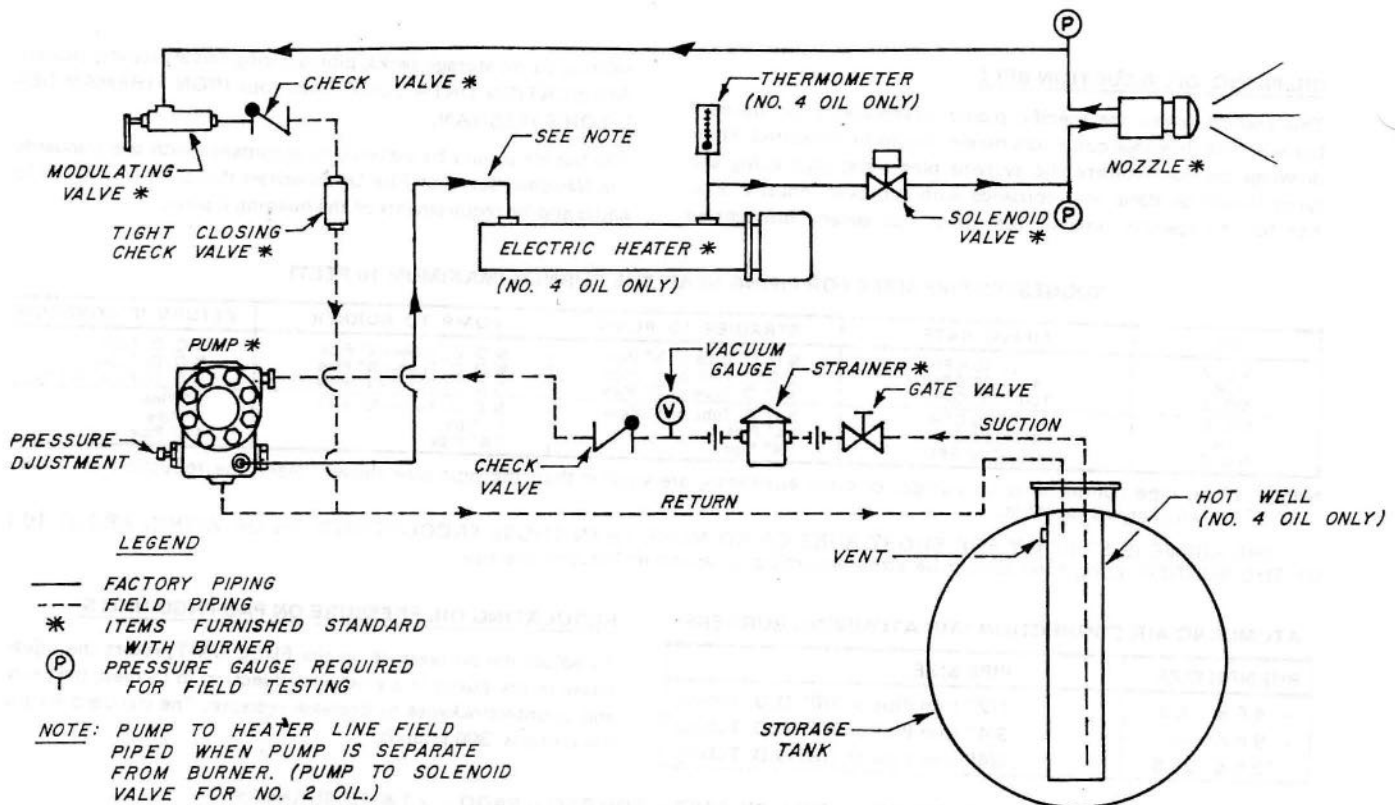

FIGURE 21B – FUEL OIL UNIT – FOR PAO – PAGO 6.3 & 9.8 & 15 BURNERS





**NO. 2 and 4 FUEL OIL PIPING SCHEMATIC -
PAO & PAGO-2.1 & 4.5 BURNERS**

SK-A-10888-C

FIGURE 22

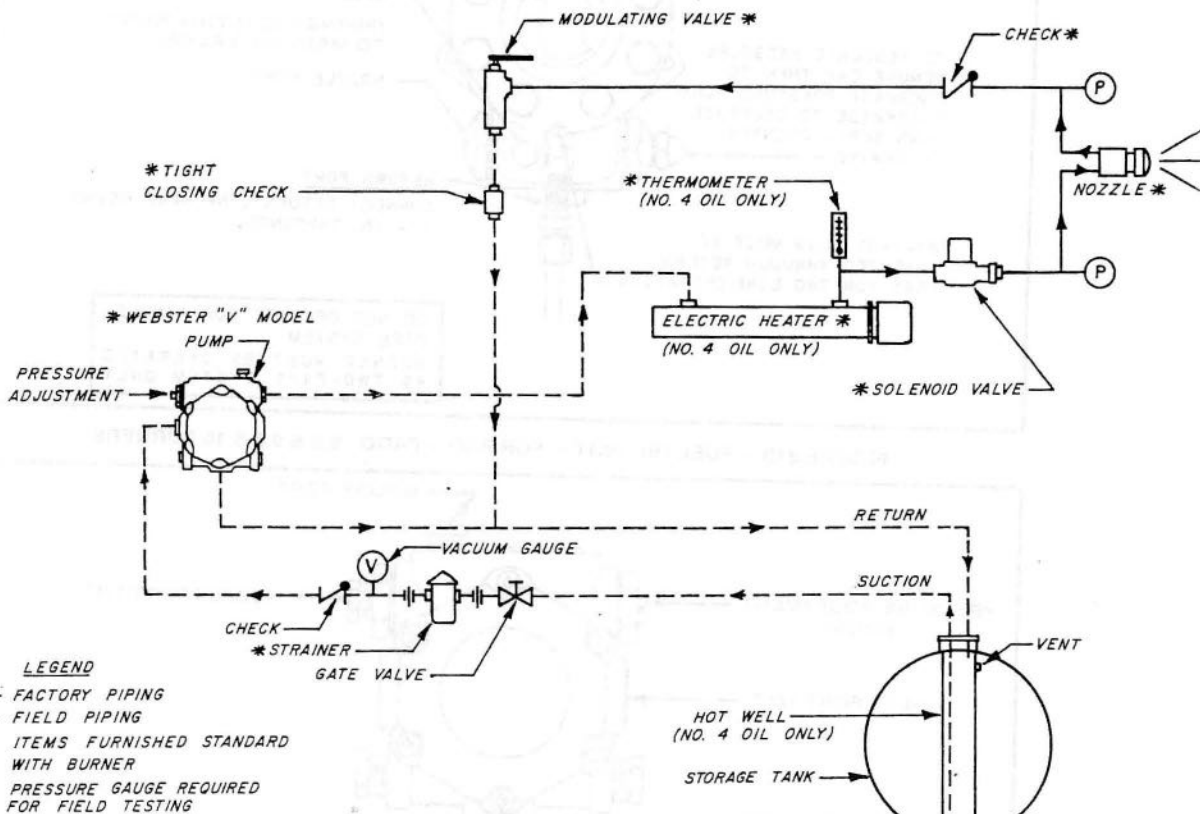

**NO. 2 and 4 FUEL OIL PIPING SCHEMATIC -
PAO-PAGO-6.3, 9.8 & 15 BURNERS**

SK-A-10909-B

FIGURE 23

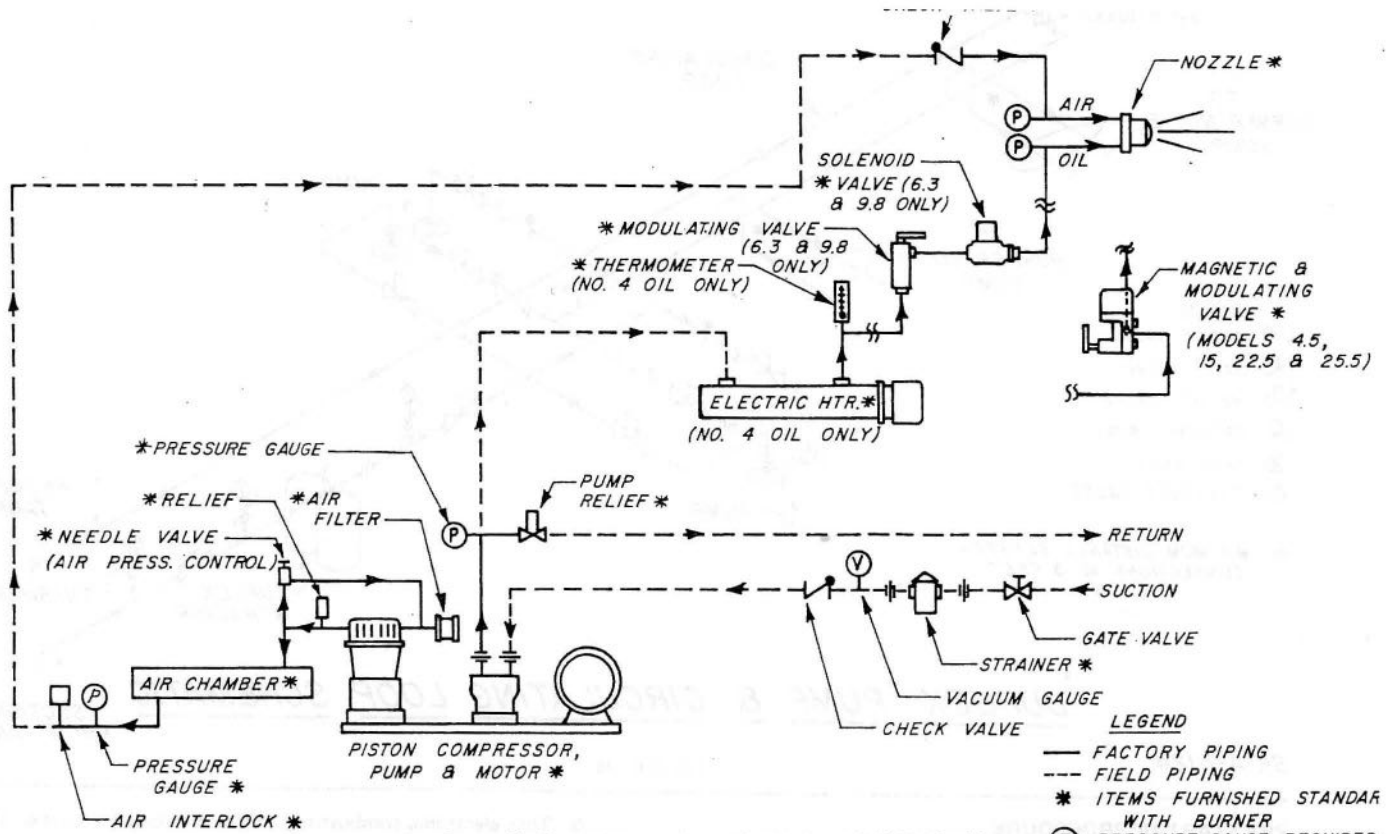

**NO. 2 and 4 FUEL OIL PIPING SCHEMATIC -
AO-AGO- 4.5, 6.3, 9.8, 15, 22.5 & 25.5 BURNERS**

SK-A-10912-A

FIGURE 24

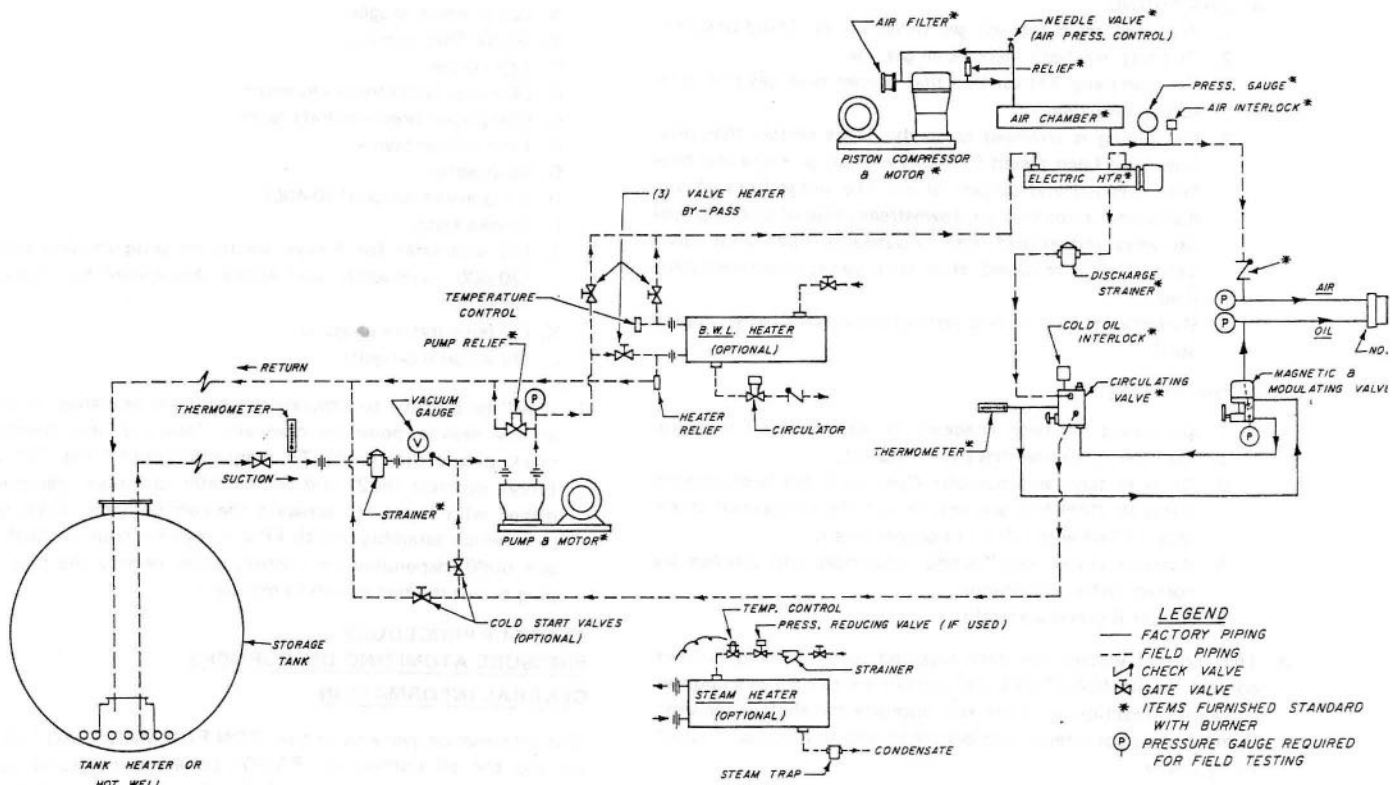

**NO. 6 FUEL OIL PIPING SCHEMATIC -
ALL AIR ATOMIZING BURNERS**

SK-B-10917-B

FIGURE 25

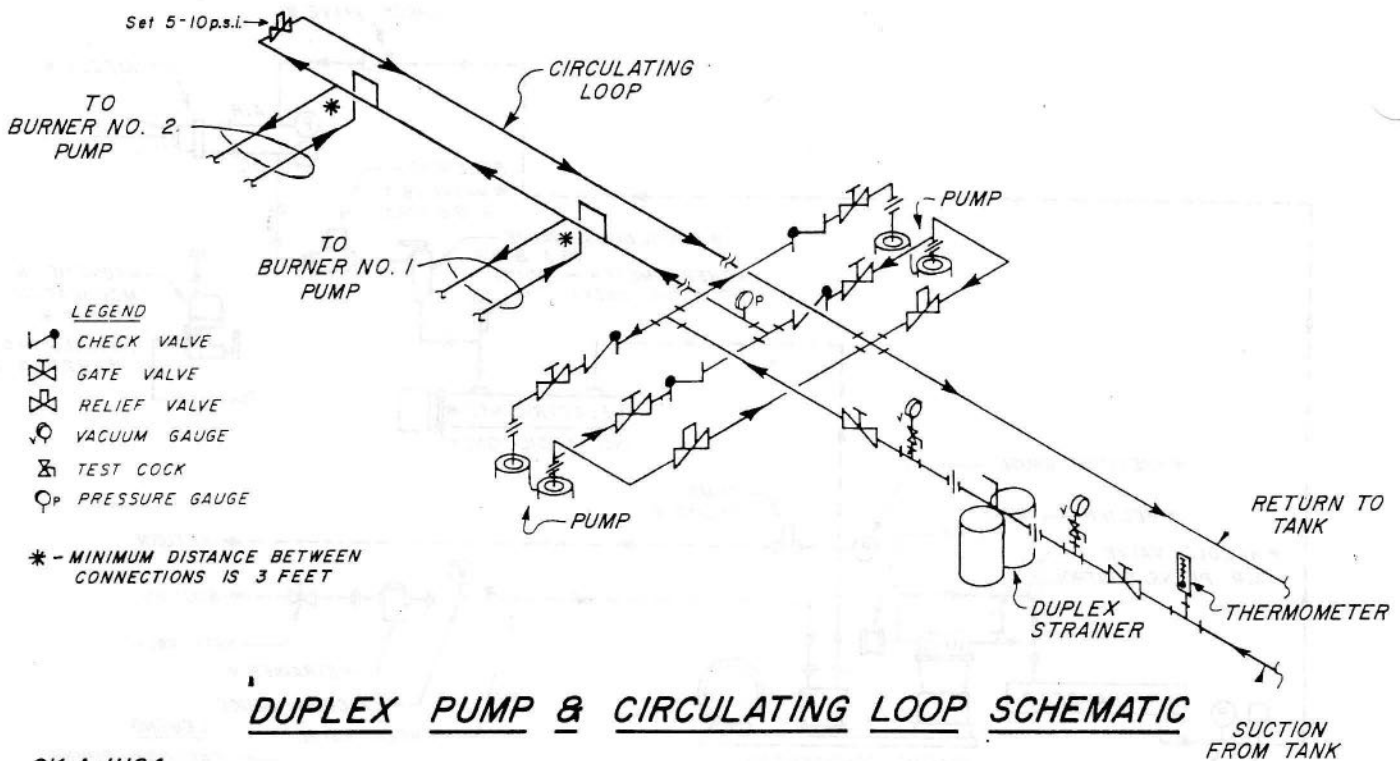

SK-A-11124

FIGURE 26

PRE START-UP PROCEDURE

1. Insure that proper size outside air opening(s) is provided in the boiler room for ventilation and for admission of air for combustion.
2. Check gas and/or oil piping and equipment to be sure:
 - A. GAS FIRING
 1. Pilot and main manual gas valves are in closed position.
 2. Dirt trap has been installed in gas line.
 3. Gas company has verified that proper type gas and pressure is available.
 4. Gas piping is arranged correctly. Make certain that pipe lines have been tested for leaks with air pressure and have been cleaned and purged of air. (To purge lines of air, disconnect pilot line on downstream side of pilot manual gas valve and extend hose to outdoors; open pilot valve until all air is removed; close pilot valve; re-connect pilot line).
 5. Burner's choke ring and settings are correct (when applicable).
 - B. OIL FIRING
 1. Oil piping has been checked for leaks with air pressure.
 2. Oil filter or strainer has been installed.
 3. Oil is in tank and pump(s) (fuel unit) has been primed. (With air atomizing burners, be sure the compressor crankcase is filled with lub oil to proper level).
 4. Burner's choke ring, nozzle, electrodes and settings are correct (when applicable).
 5. Burner is piped correctly.
3. That correct voltage has been supplied to motor and burners' control circuit. (CAUTION: Fan motors are to turn in a counter-clockwise direction — as the end opposite the shaft is viewed). Pump and air compressor motors are to turn in direction indicated by arrow.
4. That boiler, setting, breeching, wiring, water level and safety devices are in order.

5. That electronic combustion control is installed in burner. (Sometimes shipped loose to protect during transit).
6. That air shutters, or air damper, on the burner is in approximately the correct position.
7. That testing instruments are readily available. Instruments required are:
 - A. Gas pressure gauges
 - B. Stack Thermometer.
 - C. CO₂ Tester
 - D. CO tester (sometimes required)
 - E. Compound pressure-draft gauge
 - F. Line voltage tester
 - G. Stop watch
 - H. Oil pressure gauge(s) (0-400)
 - I. Smoke tester
 - J. DC voltmeter for Fireye electronic programming controls (20,000 ohm/volt); and Micro Ampmeter for Honeywell controls.
 - K. Oil temperature gauge(s)
 - L. Oil vacuum gauge(s)
8. It will be possible to simulate the program sequence, or stop it, at any desired point by manually "opening" and turning the black plastic dial knob. To manually "open" the "C" Series Fireye controls (5022 and 5023), refer to Fireye literature furnished with burner to separate the cam contacts, K-12, on the cam switch assembly. (With FP-2 Fireye controls — 6058, 6070 and 6080, depending on control, either remove the four prong plug or put the test switch to manual.)

START-UP PROCEDURE
PRESSURE ATOMIZING OIL BURNERS
GENERAL INFORMATION

This information pertains to the IRON FIREMAN "PAO" oil burners and the oil portion of "PAGO" combination gas-oil burners. (Refer elsewhere in this manual for the gas portion information pertaining to gas burners). The PAO and PAGO burners are industrial

type pressure atomizing burners which accomplish oil atomization by means of a high pressure return flow oil nozzle. These burners are equipped to burn No. 2 fuel oil and when equipped with an electric oil preheater they burn No. 4 fuel oil. (Fuel oil heavier than 125 SSU @ 100°F should not be used in the burner).

CAUTION:

When selecting oil piping, due to the fact that the PAO and PAGO burners operate with high pressures, approximately 300 psi, all pipe and fittings and valves should be 300 pound W.O.G. malleable iron; standard schedule 40 iron pipe is acceptable according to the ASME piping code. Type K or L copper tubing is acceptable for 300 psi. All tubing connections should be made with flare fittings. **DO NOT USE SOFT SOLDER OR COMPRESSION FITTINGS.**

OIL PUMPING RATE AND BURNER MODULATING RATE

BURNER REFERENCE	OIL PUMP'S PUMPING RATE	BURNERS' MODULATING RATE (RATIO)
- 2.1	68 gph	2 to 1 approx.
- 4.5	68 gph	3 to 1 approx.
- 6.3	112 gph	3 to 1 approx.
- 9.8	156 gph	3 to 1 approx.
- 15	190 gph	3 to 1 approx.

PRESSURE ATOMIZING OIL BURNERS

START-UP PROCEDURE AND DATA — OIL FIRING

The return flow nozzle used in the burner, in addition to the general construction and operating principles of a more common pressure atomizing nozzle, includes a return port at the rear of the swirl chamber. This added benefit allows the full rate, at 300 PSI, to pass through the tangential slots in the return flow nozzle and thus produce a high velocity spin in the swirl chamber, which, in turn, develops superior atomization, regardless of the actual firing rate.

A throttling modulating valve is connected to the return port of the nozzle. When the throttling valve is closed, full rate is produced; as the valve opens, some oil is returned and less is developed through the nozzle to the fire. (SEE SECTIONAL DRAWING OF RETURN FLOW NOZZLE).

The actual oil burner and nozzle oil supply and return pressures are recorded on the factory firetest report supplied in the burners' control cabinet. These pressures were based on the firing rate supplied at time the burner order was placed with the factory. The approximate oil pressures are as follows:

Oil Pump Supply Pressure 300 psi — approx.
 Oil Nozzle Return Pressure

At high fire with modulating valve closed . . 200 psi — Approx.
 At low fire with modulating valve open . . . 50 psi — Approx.

SPECIAL NOTE: THE OIL RETURN LINE TO STORAGE TANK MUST BE FREE AND OPEN ALL THE WAY TO THE TANK. MAXIMUM RETURN LINE PRESSURE MUST NEVER BE ALLOWED TO EXCEED 10 PSI.

The following numerical step by step procedure would be applicable for either No. 2 or No. 4 oil firing except that a No. 4 oil burner includes an electric oil pre-heater and requires attention to the following:

A. Make certain that the oil pre-heater is full of oil before it is electrically energized.

- B. After heater is full of oil, turn on power to the heater.
- C. The cold oil interlock switch built into the head of the heater will prevent operation until the oil is warm. Set this switch to close approximately 15° below the operating temperature. (See the section of this manual covering the heater).
- D. Adjust the oil temperature. It may vary from 115° to 150°F, depending on the viscosity of the No. 4 oil.
- E. A suction bell must be provided in the oil storage tank so that the heated oil can be concentrated for recovery.
- F. Continue with the following step by step procedure.

STEP BY STEP PROCEDURE

1. Make sure that prestart check has been completed; remember also, that you are manually operating the Flame Safeguard Programming Control (Refer to Flame Safeguard Programming Control literature furnished in the burners' control cabinet).
2. Before starting burner or opening any oil valves, be certain that check valves in suction and return lines are properly installed because any restriction or closed valve in the return line can damage burner components. (To eliminate after dribble, a factory furnished check valve is to be piped in the burners' return line). **NOTE: SHUTOFF VALVES ARE NOT TO BE INSTALLED IN OIL RETURN LINES.**
3. Install oil pressure, vacuum and temperature gauges in oil lines as are required for burner adjustment.
4. Fill the oil strainer with fuel oil or lubricating oil.
5. Open manual oil valve.
6. Energize the oil pump motor by manually lifting the linestarter until oil pump and system are full of oil.
7. With system full of oil, the oil pump pressure at the pump should be 300 PSI.
 When burning No. 4 oil, energize the electric oil heater and set the oil temperature.
8. Refer to linkage elsewhere in this manual to assure factory settings were not disturbed during installation or transit.
9. Open the manual gas pilot valve.
10. Turn the burner on-off switch to the on position. Slowly turn the dial on the programming control to position "1"; the burner fan and oil pump should have been started, and at this point, the ignition and pilot flame should be visible. Pilot gas pressure is 3 to 5" w.c., normally. (6 to 11" with L.P. gas).
11. Check scanner pick up as indicated on the voltmeter. This should be a steady 80 volts or more with FP-2 controls and is to be 15 to 20 volts with "C" Series Controls.
12. Once the pilot has been checked and is properly working, set the programmer to position "2"; the main oil valve should be open and the burner should light instantly.
13. Establish the low fire setting. Observe the main flame. and if the mixture is too rich, or lean, adjust the oil and/or air rate via the linkage. A steady, bright, low fire of 10% to 11% CO₂ should be obtained. The oil valve lever may require some resetting to clear the fire or to obtain the necessary rate of CO₂. Remember that with return nozzles, closing the modulating valve increases the firing rate.

14. With the programmer set in position "3", the pilot will shut off. Position "4" will allow the burner to modulate. The high fire can be established manually by using the manual potentiometer on the burners' control cabinet to allow a change in high rate and linkage by varying degrees. Make a tentative advance to high fire. If the fire becomes smoky, return to low fire and, without changing the low fire setting, reset the position of the swivel on the oil valve lever further away from the hub, so the motion of the valve is less rapid. If the fire becomes too lean, move the swivel closer to the hub so the valve closes more rapidly and thus delivers more oil to the fire, less to return. (REFER TO LINKAGE elsewhere in this manual.)
15. Make small changes at a time, and make a trial run after each change until the desired high fire with 12% CO₂ is obtained.
16. Turn off burner. Securely tighten all linkage and bolts.
17. Having both the low and high fire set, re-position the electronic control to automatic, in lieu of manual control.
18. Refer to "Burner Sequence of Operation" elsewhere in this manual and Flame Safeguard Programming literature furnished with the burner for "Safety Shut Down" and for pilot and main flame tests. Restart burner and check safety shut down by removing flame detector and covering with the hand when possible.
19. After checking safety shut down, restart burner and check each operating limit and low water cutoff control. Recycle burner several times to be sure all controls are functioning properly and the fuel valve closes.

START-UP PROCEDURE

GAS BURNERS

GENERAL INFORMATION

This information pertains to the IRON FIREMAN "AG" Gas Burners, and the gas portion of the PAGO and AGO Combination Gas/Oil Burners. (Refer elsewhere in this manual for the oil portion information pertaining to the specific oil burner for oil firing). The AG Burners are industrial burners of the power type. They are primarily used to burn natural gas, but can, or may be, equipped to burn other types of gas.

START-UP PROCEDURE – GAS BURNERS

STEP BY STEP PROCEDURE

1. Make sure that prestart check has been completed; remember, also that you are manually operating the Flame Safeguard Programming Control. (Refer to Flame Safeguard Programming Control literature furnished in the burners' control cabinet).
2. With a knowledge of the required firing rate, available line gas pressure, and gas piping group pressure drop calculations, proceed with burner start-up.
3. Adjust combustion air inlet shutters (or damper) and make the initial setting at approximately 1/8" open for rates to approximately 10,500 MBH and 3/8" for higher maximum rates.
4. Set the gas butterfly valve at approximately the 1/8" open position.
5. (With combination gas/oil burners, the oil portion should have been adjusted and started-up before attempting to start-up on gas firing. Make certain the oil pump is primed and full of oil before attempting to light up on gas firing). It will be necessary to make the gas butterfly valve follow the low, medium and high fire positions established for the air damper arms for oil firing.

This condition will also apply to the modulating motor travel in order that quick changeover can be made without disturbing these adjustments.

6. Open the manual gas pilot valve.
7. With the main manual gas valve closed, set the programming control to position "1"; the burner fan should have been started and, at this point, the ignition and pilot flame should be visible. Check to be certain that ignition was proper and was detected by the flame detector.
8. Check scanner pick up as indicated on the voltmeter. This should be a steady 80 volts or more with FP-2 controls and is to be 15 to 20 volts with "C" Series Controls.
9. Once the pilot has been checked and is properly working, set the programmer to position "2", observe the main electric gas valve(s) to be certain they are open; then slowly open the main manual gas valve(s) until the main burner ignites. (We strongly suggest a second person to observe as visual aid during this period of start-up).

CAUTION: If the main burner flame fails to ignite immediately, the manual gas valve should be quickly closed. The burner should be shut down and possible reasons for failure determined and corrected. If the pilot is working correctly, and the main automatic fuel valve(s) are open, the gas mixture may have been too lean. Burners should be adjusted at the butterfly valve, not the gas pressure regulator.

10. The burner now may be restarted; and when the pilot is proven, open the manual gas valve slowly until the main flame ignites. The low fire setting position should be established first. Observe the main flame; and if the mixture is too rich, or lean, adjust the gas rate by way of the gas butterfly valve and/or manual gas valve. (Refer to linkage elsewhere in this manual). If fire is very lean, open manual valve further. If too rich, close the butterfly slightly. Continue to adjust until manual gas valve is full open and fire is satisfactory. The fire should burn in a uniform pattern and be stable. Check CO₂; this should be between 8 and 9% when burning natural gas.
11. With the programmer set in position "3", the pilot will shut off. Position "4" will allow the burner to modulate. The high fire can be established manually by using the manual potentiometer on the burners' control cabinet to allow a change in high rate and linkage by varying degrees.

Make a tentative advance of the linkage toward high fire. Observe the fire, and if it tends to become too lean, return to the original low fire setting and move the swivel on the drive lever (on the bottom of the air damper shaft) further out and away from the hub, in order to make the butterfly valve open more rapidly in relation to the air damper. If the fire becomes too rich as it advances, set the linkage so the butterfly valve moves less rapidly in relation to the air. Continue to make tentative advances toward high fire until the maximum required rate is reached and satisfactory modulating range is obtained. Mark the high fire setting on the modulating linkage. At this point, the fuel air ratio has been adjusted for the entire range and all linkage and bolts should be securely tightened.
12. Having both the low and high fire settings at approximately 8 CO₂, re-position the electronic control to automatic.
13. Refer to "Burner Sequence of Operation" elsewhere in this manual and flame safeguard programming literature furnished with the burner for "Safety Shut Down" and/or pilot and main flame

tests. Restart burner and check safety shutdown by removing flame detector and covering with the hand when possible.

14. After checking safety shutdown, restart burner and check each operating limit and low water cutoff control. Recycle burner several times to be sure all controls are functioning properly and that fuel valve closes.

START-UP PROCEDURE

AIR ATOMIZING OIL BURNERS - - NO. 2 AND 4 OIL

GENERAL INFORMATION

This information pertains to the IRON FIREMAN "AO" Oil Burners and the oil portion of the "AGO" combination gas/oil burners. (Refer elsewhere in this manual for the gas portion information pertaining to gas burners). The AO and AGO Burners are industrial type burners, utilizing compressed air to atomize the fuel oil into a fine spray for rapid mixing with the combustion air. These burners are equipped to burn No. 2 oil and when equipped with electric oil pre-heating equipment, they burn No. 4, No. 5 or No. 6 fuel oil.

CAUTION:

When selecting oil line piping, fittings, valves, tanks, etc., be certain to select equipment and sizing in accordance with good industry practice. For general assistance, request an APPLICATION DATA BOOK from your IRON FIREMAN DEALER OR SALESMAN.

START-UP PROCEDURE AND DATA - NO. 2 OR NO. 4 OIL FIRING

Many of the actual oil burner and nozzle air and oil supply and return pressures are recorded on the factory firetest report supplied in the burners' control cabinet. These pressures were based on the firing rate supplied at the time the burner order was placed with the factory. Some of the approximate settings are listed on the table, "SETTINGS AND CAPACITIES".

The following numerical step by step procedure would be applicable for either No. 2 or No. 4 oil firing except that a No. 4 oil burner includes an electric oil pre-heater and requires attention to the following:

- A. Make certain that the oil pre-heater is full of oil before it is electrically energized.
- B. After heater is full of oil, turn on power to the heater.
- C. The cold oil interlock switch built into the head of the heater will prevent operation until the oil is warm. Set this switch to close approximately 15° below the operating temperature. (See the section of this manual covering the heater).
- D. Adjust the oil temperature. It may vary from 115° to 150° F, depending on the viscosity of the No. 4 oil.
- E. Continue with the following step by step procedure.

STEP BY STEP PROCEDURE

1. Make sure that prestart check has been completed; remember also that you are manually operating the Flame Safeguard Programming Control. (Refer to Flame Safeguard Programming Control literature furnished in the burners' control cabinet).
2. Before starting burner or opening any oil valves, be certain that check valves in suction and return lines are properly installed.

3. Install oil pressure, vacuum and temperature gauges in oil lines as are required for burner adjustment.
4. Fill the oil strainer with fuel oil or lubricating oil.
5. Open manual oil valve; back off all tension on relief valve before priming oil pump.
6. Energize the oil pump motor by manually lifting the linestarter until oil pump and system are full of oil.
7. With system full of oil, the oil pressure should be adjusted as listed on the SETTINGS AND CAPACITY TABLE -- elsewhere in this manual for the specific burner size.

When burning No. 4 oil, energize the electric oil heater and set the oil temperature.

8. Refer to linkage elsewhere in this manual to assure factory settings were not disturbed during installation or transit.
9. Open the manual gas pilot valve.
10. Turn the burner on-off switch to the On position. Slowly turn the dial on the programming control to position "1"; the burner fan and oil pump should have been started, and at this point, the ignition and pilot flame should be visible. Pilot gas pressure is 3 to 5" w.c., normally.
11. Check scanner pick up as indicated on the voltmeter. This should be a steady 80 volts or more with FP-2 controls and 15 to 20 volts with "C" Series Controls.
12. Once the pilot has been checked and is properly working, set the Programmer to position "2"; the main oil valve should be open and the burner should light instantly.
13. Establish the low fire setting. Observe the main flame; and if the mixture is too rich, or lean, adjust the oil and/or air rate via the linkage. (Check air pressure setting at nozzle; it is adjusted at the needle valve on the air compressor and should be adjusted at the approximate setting in the table. A steady, bright, low fire of 10% to 11% CO₂ should be obtained. The oil valve lever may require some resetting to clear the fire or to obtain the necessary rate of CO₂).
14. With the programmer set in position "3", the pilot will shut off. Position "4" will allow the burner to modulate. The high fire can be established manually by using the potentiometer on the burners control cabinet to allow a change in high rate and linkage by varying degrees. Make a tentative advance to high fire. If the fire becomes smoky, return to low fire and, without changing the low fire setting, reset the position of the swivel on the oil valve lever further away from the hub, so the motion of the valve is less rapid. If the fire becomes too lean, move the swivel closer to the hub so the valve opens more rapidly and thus delivers more oil to the fire. (Refer to Linkage elsewhere in this manual). Check the air pressure on the air compressor; it should be per the approximated settings listed in the SETTINGS AND CAPACITY TABLE.
15. Make small changes at a time, and make a trial run after each change until the desired high fire with 12% CO₂ is obtained.
16. Turn off burner. Securely tighten all linkage and bolts.
17. Having both the low and high fire set, re-position the electronic control to automatic, in lieu of manual control.
18. Refer to "Burner Sequence of Operation" elsewhere in this manual and Flame Safeguard Programming literature furnished with

the burner for "Safety Shut Down" and for pilot and main flame tests. Restart burners and check safety shut down by removing flame detector and covering with the hand when possible.

19. After checking safety shut down, restart burner and check each operating limit and low water cutoff control. Recycle burner several times to be sure all controls are functioning properly and that fuel valve closes.
20. Allow burner to cycle several times to be sure it will run automatically satisfactorily.

START-UP PROCEDURE

AIR ATOMIZING OIL BURNERS -- NO. 5 AND 6 OIL

GENERAL INFORMATION

This information pertains to the IRON FIREMAN "AO" Oil Burners and the oil portion of the "AGO" Combination gas/oil burners. (Refer elsewhere in this manual for the gas portion information pertaining to gas burners). The AO and AGO burners are industrial type burners, utilizing compressed air to atomize the fuel oil into a fine spray for rapid mixing with the combustion air.

CAUTION:

When selecting oil line piping, fittings, valves, tanks, etc., be certain to select equipment and sizing in accordance with good industry practice. For general assistance, request an APPLICATION DATA BOOK from your IRON FIREMAN DEALER OR SALESMAN.

START-UP PROCEDURE AND DATA - NO. 5 OR NO. 6 OIL FIRING

Many of the actual oil burner and nozzle air and oil supply and return pressures are recorded on the factory firetest report supplied in the burners' control cabinet. These pressures were based on the firing rate supplied at the time the burner order was placed with the factory. Some of the approximate settings are listed in the table, "SETTINGS AND CAPACITIES".

IMPORTANT CONSIDERATIONS

A. OIL HEATERS:

Auxiliary heaters are always required for heavy No. 5 and No. 6 oils. The electric heater has capacity only for start up of the burner.

A steam or below the water line heater, or a full electric line heating system is a must. Such heaters should be adjusted to give the final operating temperature, if possible. If boiler conditions do not permit the heater to develop the required temperature, set the steam or water controller to obtain the maximum nominal (say, 160°) to retain some control over the temperature. The electric heater will then raise the oil to the final burning temperature.

B. HOT WELL:

A hot well in the tank to recover returned hot oil is a must with No. 5 and No. 6 oil.

C. NOZZLE CLEANING:

On an initial start up, dirt and pipe chips are apt to collect in the nozzle. A one-sided or distorted fire will result. The nozzle may be disassembled and washed with solvent. Hard deposits should be removed with a wood stick, never with a file or hard metal probe. The center pin in Monarch nozzles is factory set and must not be changed.

STEP BY STEP PROCEDURE

1. Make sure that prestart check has been completed; remember

also, that you are manually operating the Flame Safeguard Programming Control. (Refer to Flame Safeguard Programming Control literature furnished in the burner's control cabinet)

2. Before starting burner or opening any oil valves, be certain that check valves in suction and return lines are properly installed.
3. Install oil pressure, vacuum and temperature gauges in oil lines as are required for burner adjustment.
4. Fill the oil strainer with fuel oil or lubricating oil.
5. Open manual oil valve; back off all tension on relief valve before priming oil pump. Open key valve to wide open position.
6. Energize the oil pump motor by manually lifting the linestarter until oil pump and system are full of oil.
7. With the system full of oil, set the pressure at the pump by adjusting the line relief valve. Set the pressure in the magnetic valve by adjusting the circulating valve as listed on the "SETTINGS AND CAPACITY TABLE".
8. Energize the electric heater and allow the oil to circulate. When No. 6 oil reaches about 175°F, set the cold oil interlock to cut in No. 5 oil may cut in at about 150°F. Oil operating temperatures should be about 190 to 200° for No. 6 oil and about 180° for No. 5 oil. This will vary with the particular oil used. An atomizing viscosity of about 150 SSU at the nozzle is required.
9. Refer to linkage elsewhere in this manual to assure factory settings were not disturbed during installation or transit.
10. Open the manual gas pilot valve.
11. Turn the burner on-off switch to the ON position. Slowly turn the dial on the programming control to position "1"; the burner fan and oil pump should have been started, and at this point, the ignition and pilot flame should be visible. Pilot gas pressure is 3 to 5" w.c. normally. (6 to 11" with L.P. gas).
12. Check scanner pick up as indicated on the voltmeter. This should be a steady 80 volts or more with FP-2 controls and is to be 15 to 20 volts with "C" Series Controls.
13. Once the pilot has been checked and is properly working, set the Programmer to position "2"; the main oil valve should be open and the burner should light instantly.
14. Establish the low fire setting. Observe the main flame; and if the mixture is too rich, or lean, adjust the oil and/or air rate via the linkage. (Check air pressure setting at nozzle; it is adjusted at the needle valve on the air compressor and should be adjusted at the approximate setting in the table. A steady, bright, low fire of 10% to 11% CO₂ should be obtained. The oil valve lever may require some resetting to clear the fire or to obtain the necessary rate of CO₂.
15. With the programmer set in position "3", the pilot will shut off. Position "4" will allow the burner to modulate. The high fire can be established manually by using the potentiometer on the burners control cabinet to allow a change in high rate and linkage by varying degrees. Make a tentative advance to high fire. If the fire becomes smoky, return to low fire and, without changing the low fire setting, reset the position of the swivel on the valve lever further away from the hub, so the motion of the valve is less rapid. If the fire becomes too lean, move the swivel closer to the hub so the valve opens more rapidly and thus delivers more oil to the fire. (Refer to Linkage elsewhere in this manual). Check the air pressure on the air compressor; it should be per the

approximated settings listed in the SETTINGS AND CAPACITY TABLE.

16. Make small changes at a time, and make a trial run after each change until the desired high fire with 12% CO₂ is obtained.
17. Turn off burner. Securely tighten all linkage and bolts.
18. Having both the low and high fire set, re-position the electronic control to automatic, in lieu of manual control.
19. Refer to "Burner Sequence of Operation" elsewhere in this manual and Flame Safeguard Programming Literature furnished with the burner for "Safety Shut Down" and for pilot and main flame tests. Restart burner and check safety shut down by removing flame detector and covering with the hand when possible.
20. After checking safety shut down, restart burner and check each operating limit and low water cutoff control. Recycle burner several times to be sure all controls are functioning properly and that fuel valve closes.
21. Allow burner to cycle several times to be sure it will run automatically satisfactorily.

SETTINGS AND CAPACITIES (APPROXIMATE) AIR ATOMIZING OIL BURNERS

BURNER	BURNERS' MODULATING RATE (RATIO)	OIL	APPROX OIL TEMP.	SUPPLY LINE PRESSURE PUMP	OIL PUMP CIRCULATING RATES	* AIR PRES-SURE @ NOZZLE	* OIL PRES-SURE @ NOZZLE	AIR PRES-SURE DUR-ING PRE-PURGE AT NOZZLE	OIL PRESSURE DURING PRE PURGE IN MAGNETIC VALVE
AO-2-4.5	3 to 1	No. 2	Tank	35 psi	114 GPH	24 19	21 15	18	30
AO-4-4.5	3 to 1	No. 4	115 To 150	40 psi	114 GPH	24 19	26 20	18	35
AO-6-4.5	3 to 1	No. 6	180 To 210	50 psi	100 GPH	33 28	38 31	27	45
AO-2-6.3	3 to 1	No. 2	Tank	40 psi	114 GPH	21 13	20 10	10	35
AO-4-6.3	3 to 1	No. 4	115 To 150	40 psi	114 GPH	21 13	20 10	10	35
AO-6-6.3	3 to 1	No. 6	180 To 210	45 psi	100 GPH	21 15	25 12	11	40
AO-2-9.8	3 to 1	No. 2	Tank	45 psi	114 GPH	20 15	24 13	12	40
AO-4-9.8	3 to 1	No. 4	115 To 150	45psi	114 GPH	23 17	26 14	14	40
AO-6-9.8	3 to 1	No. 6	180 To 210	45 psi	200 GPH	23 17	26 14	14	40
AO-2-15	4 to 1	No. 2	Tank	65 psi	210 GPH	36 29	48 22	26	60
AO-4-15	4 to 1	No. 4	115 To 150	65 psi	210 GPH	36 29	48 22	26	60
AO-6-15	4 to 1	No. 6	180 To 210	75 psi	200 GPH	43 30	56 30	27	70
AO-2-22.5	4 to 1	No. 2	Tank	70 psi	210 GPH	26 17	36 11	10	50
AO-4-22.5	4 to 1	No. 4	125 To 150	75 psi	210 GPH	28 19	40 14	11	55
AO-6-22.5	4 to 1	No. 6	210	75 psi	300 GPH	32 22	46 15	12	60
AO-2-25.5	4 to 1	No. 2	Tank	75 psi	210 GPH	36 19	50 16	13	65
AO-4-25.5	4 to 1	No. 4	125 To 150	75 psi	210 GPH	42 23	56 20	14	70
AO-6-25.5	4 to 1	No. 6	210	80 psi	300 GPH	45 26	60 24	15	75

* Largest number = @ high fire rate, and smaller number = @ low fire rate.

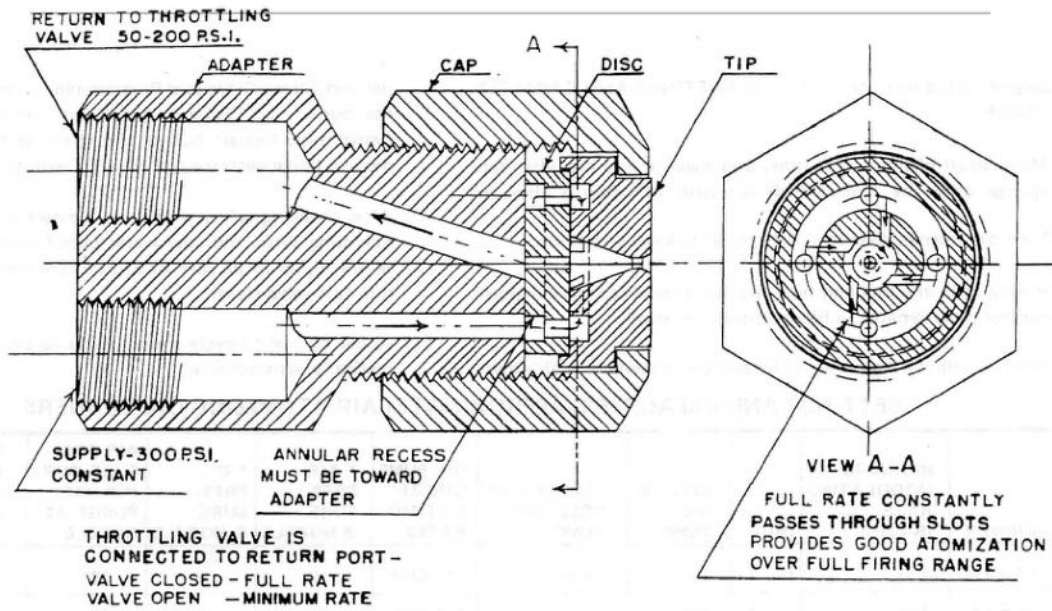

**PRESSURE ATOMIZING RETURN FLOW NOZZLE
USED ON PAO AND PAGO BURNERS
FIGURE NO. 27**

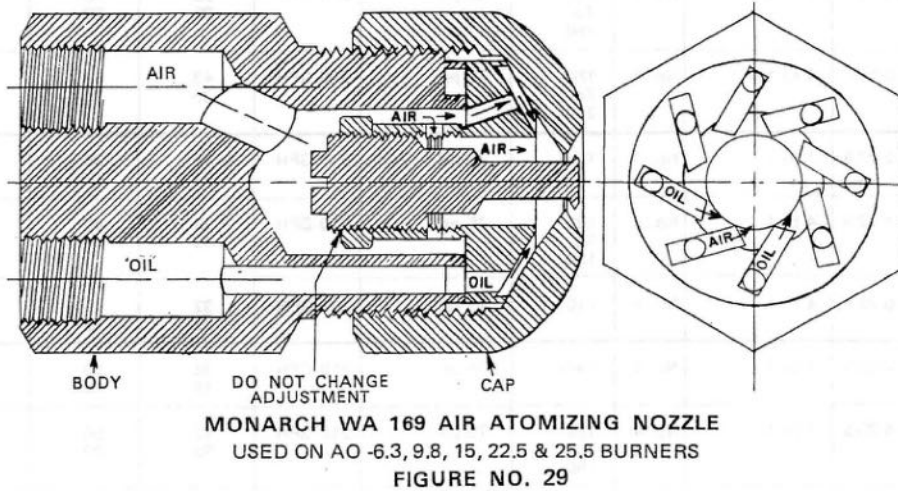
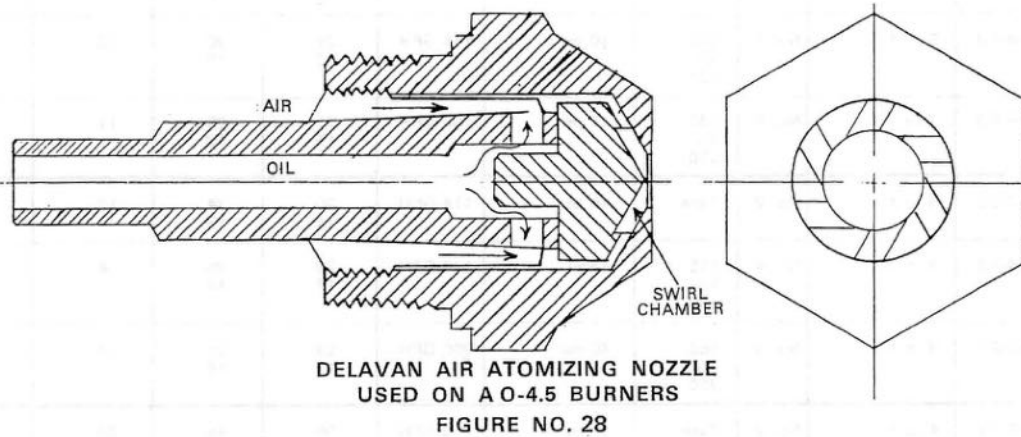

LINKAGE (Air & Fuel Adjustments)

The purpose of linkage is to regulate the amount of required combustion air in correct proportion to the amount of fuel required to obtain the burners' desired firing rate at maximum efficiency. To obtain the desired results, the linkages can be manually adjusted at various points between the air damper and modulating fuel valves.

At the factory, the burner was tested in a tightly sealed Scotch type boiler and vented to atmosphere thru a stub stack. In effect, the burner fired against a back pressure in the combustion area which made it necessary to allow the burners' air damper to open wider to obtain proper volume of fuel - air mixture than would normally be required for a boiler operating with a slight draft in the combustion area.

If then, at the job site location, an oil burner is installed in a boiler having a negative draft condition, it would be necessary to close the air damper some since the positive pressure against the air fan would be eliminated. The amount of change required can be obtained by checking the CO₂ and Draft/Pressure with testing instruments (ORSAT AND COMPOUND GAUGE). The drawing illustrates that the air damper movement can be decreased at two points and the fuel input area movement can be increased at two points until satisfactory combustion and desired input is obtained.

Make sure that all linkage connection screws and swivels are set securely before attempting to adjust linkage arrangement.

Refer to the drawing contained in this publication for the exact burner model you are working with so that you can make the adjustments required in the shortest possible time. The drawing illustrates a certain set of dimensions that would allow maximum low-to-high fire movement of the modulating motor, combustion air damper, and fuel oil modulating valve; however, you can choose any variety of adjustments necessary to suit the particular job requirements by referring to the directions listed on the drawing.

The drawing, for gas firing, illustrates the gas butterfly valve and direction of increase or decrease of fuel, gas. The exact setting will have to be determined at the job site due to local variables -- Btu content, specific gravity, and gas pressure used. Follow start-up instructions located elsewhere in this manual.

Be sure to make all adjustments carefully and in small increments. After completing the adjustments, lock all linkage connections securely and mark the positions for reference.

NOTE: The adjustable damper linkage illustrated in drawings SK-B-11118 and SK-B-11119 are correct; however for some special applications where design would prefer unequal movement of both damper blades, the blades are slotted, and the linkage connector can be adjusted to allow either blade to lead. If necessary to balance an uneven fire pattern, this arrangement diverts the air stream either up or down as desired.

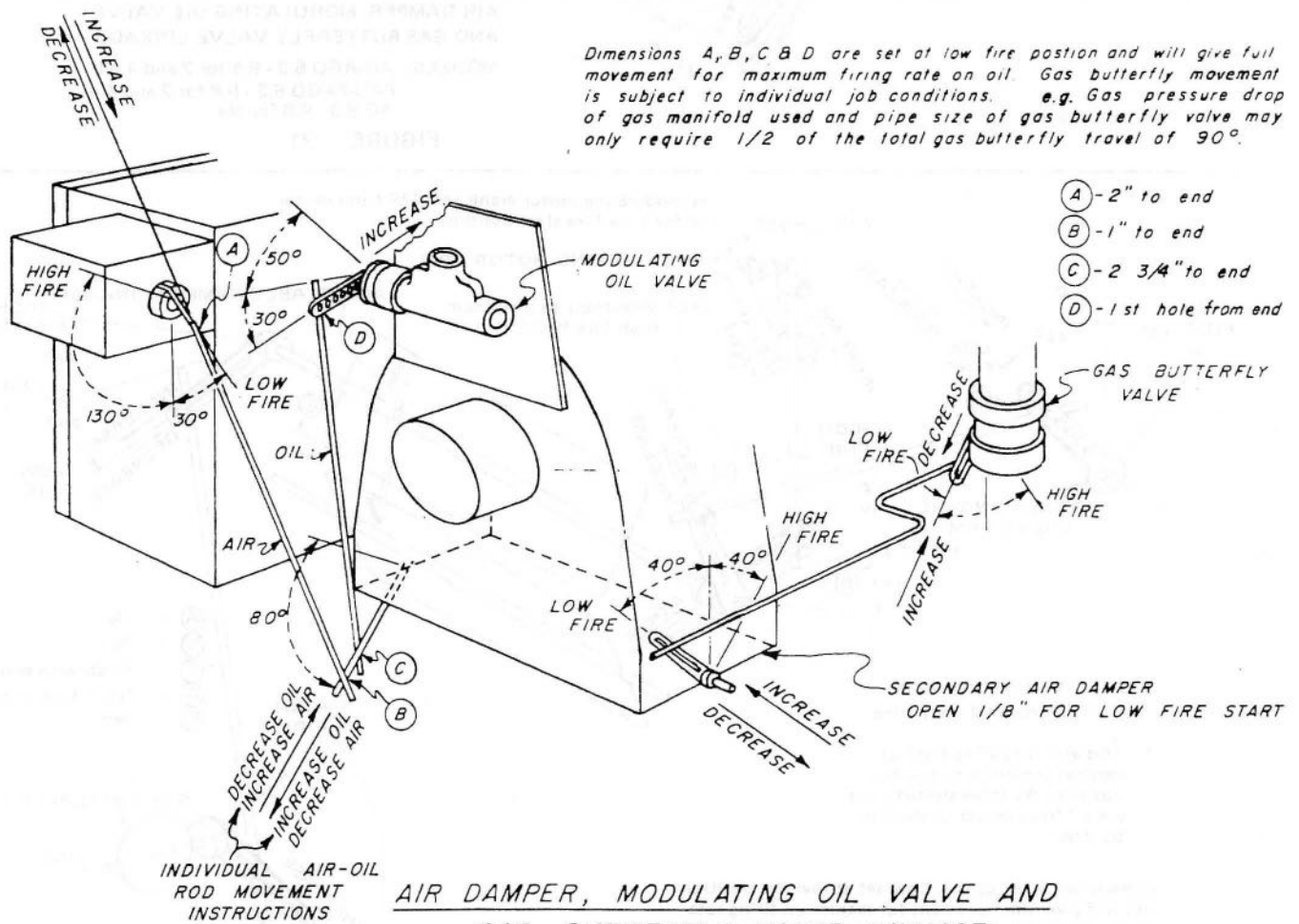

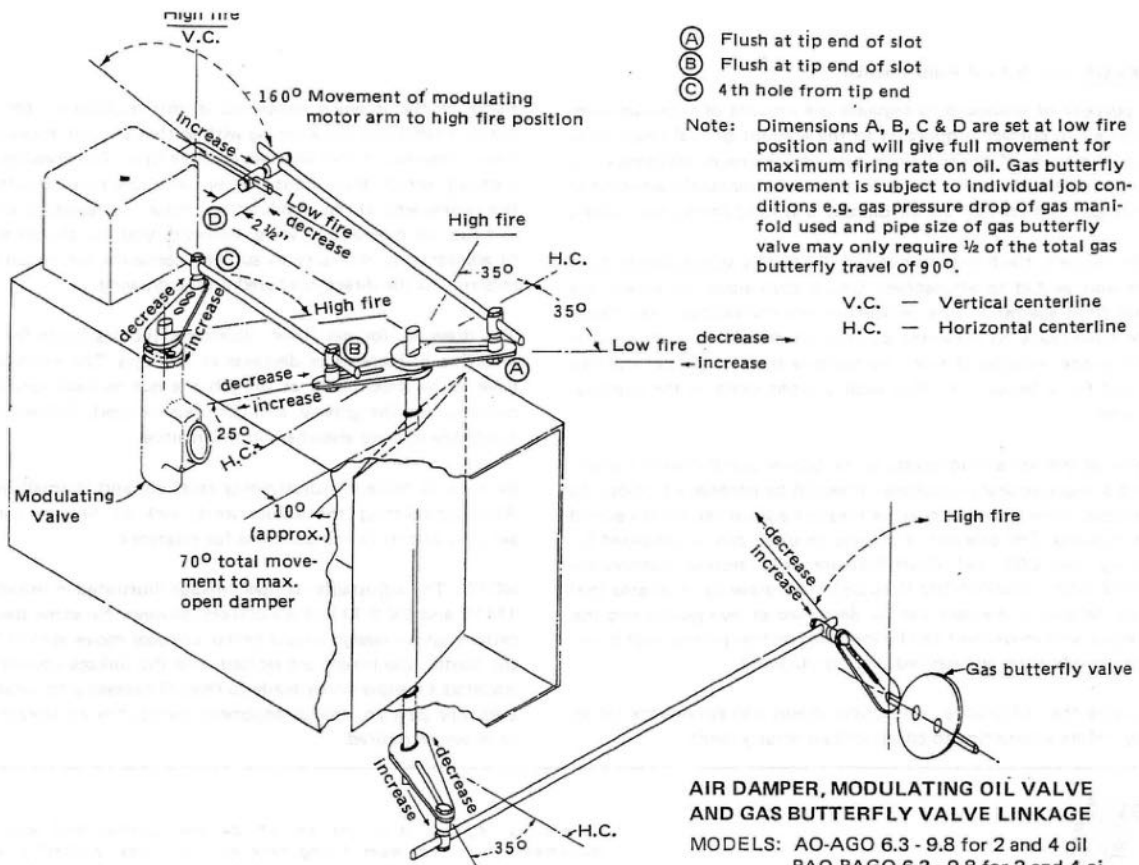

SK-C-11125-A

AIR DAMPER, MODULATING OIL VALVE AND GAS BUTTERFLY VALVE LINKAGE

MODELS: AO-AGO 6.3 - 9.8 for 2 and 4 oil
 PAO-PAGO 6.3 - 9.8 for 2 and 4 oil
 AG 6.3 - 9.8 for gas

FIGURE 31

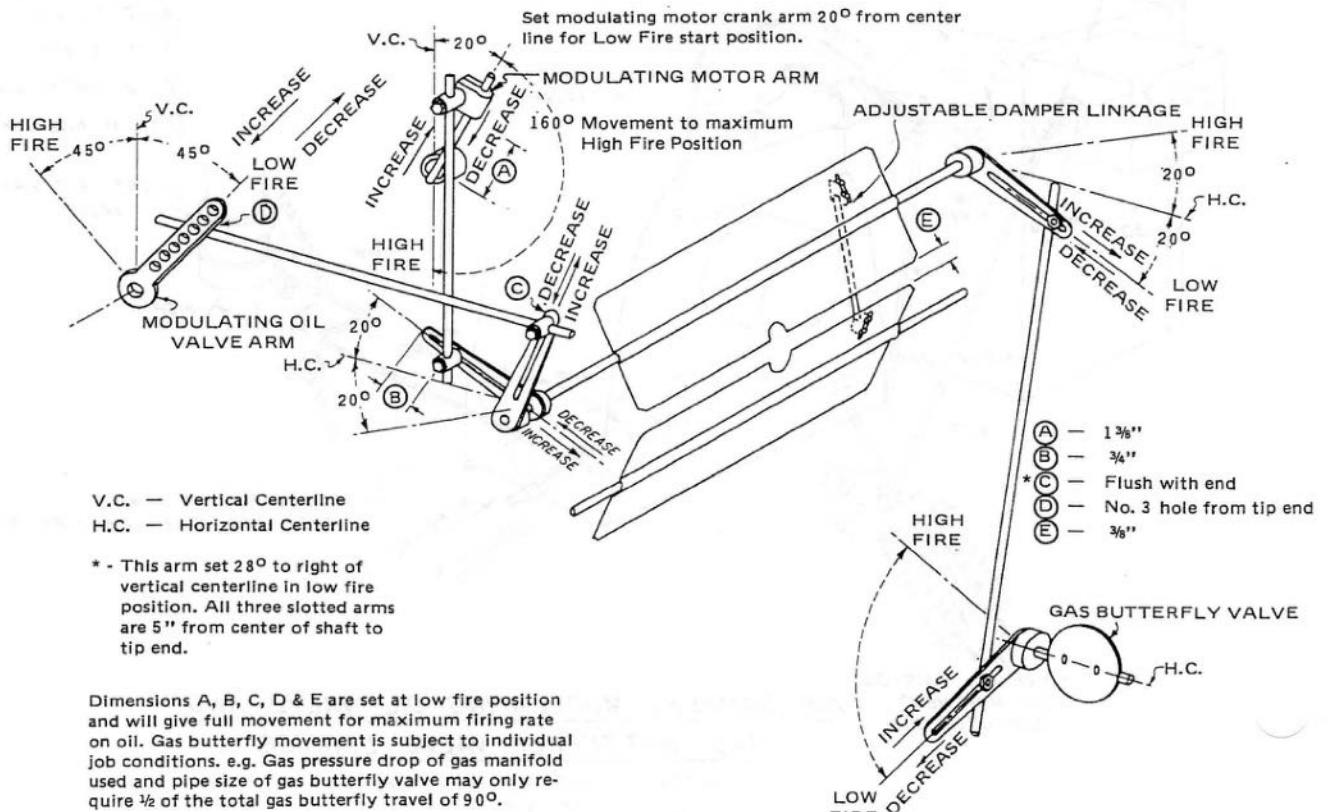

SK-B-11119-A

FIGURE 32

AIR DAMPER, MODULATING OIL VALVE AND GAS BUTTERFLY VALVE LINKAGE

MODELS: PAO, PAGO - 15

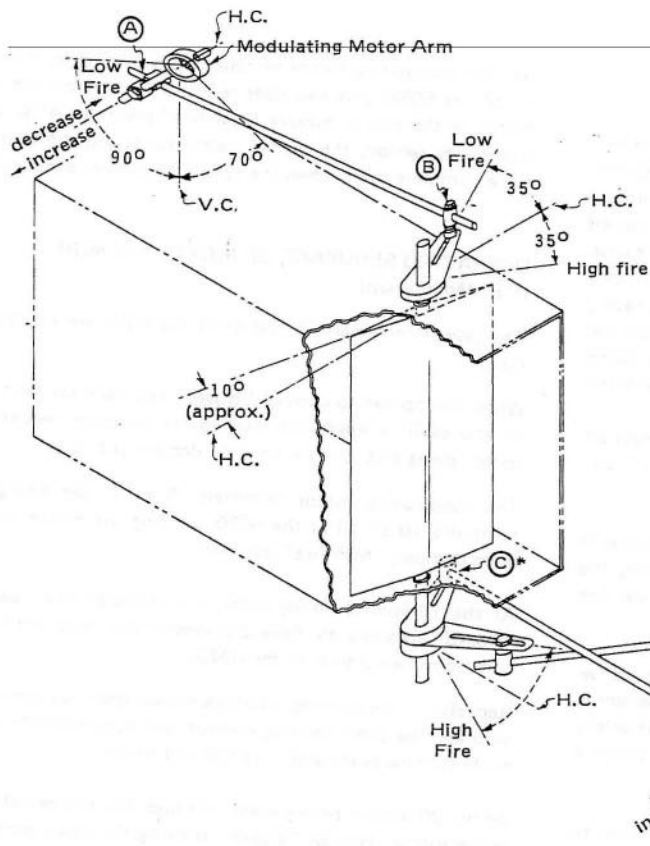

Note: Dimensions A, B, C & D are set at low fire position and will give full movement for maximum firing rate on oil. Gas butterfly movement is subject to individual job conditions. e.g. Gas pressure drop of gas manifold used and pipe size of gas butterfly valve may only require 1/2 of the total gas butterfly travel of 90°.

V.C. — Vertical Centerline
H.C. — Horizontal Centerline

Slotted arms are 3" from center of shaft to tip end.

- (A) 2 3/4" from end of arm to center of rod
- (B) Flush at tip end of slot
- (C) Flush at tip end of slot
- (D) 5th hole from tip end

* This arm set identical to arm shown at B.

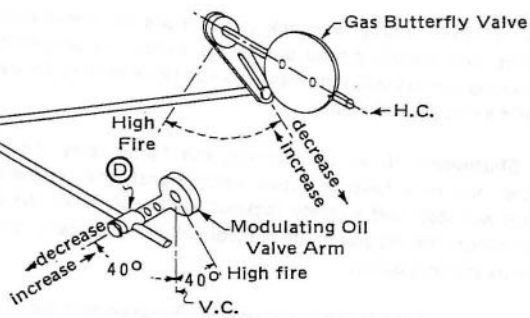

AIR DAMPER, MODULATING OIL VALVE AND GAS BUTTERFLY VALVE LINKAGE
MODELS: AO-AGO 6.3 - 9.8 for 5 and 6 oil

SK - C - 11131 - A

FIGURE 33

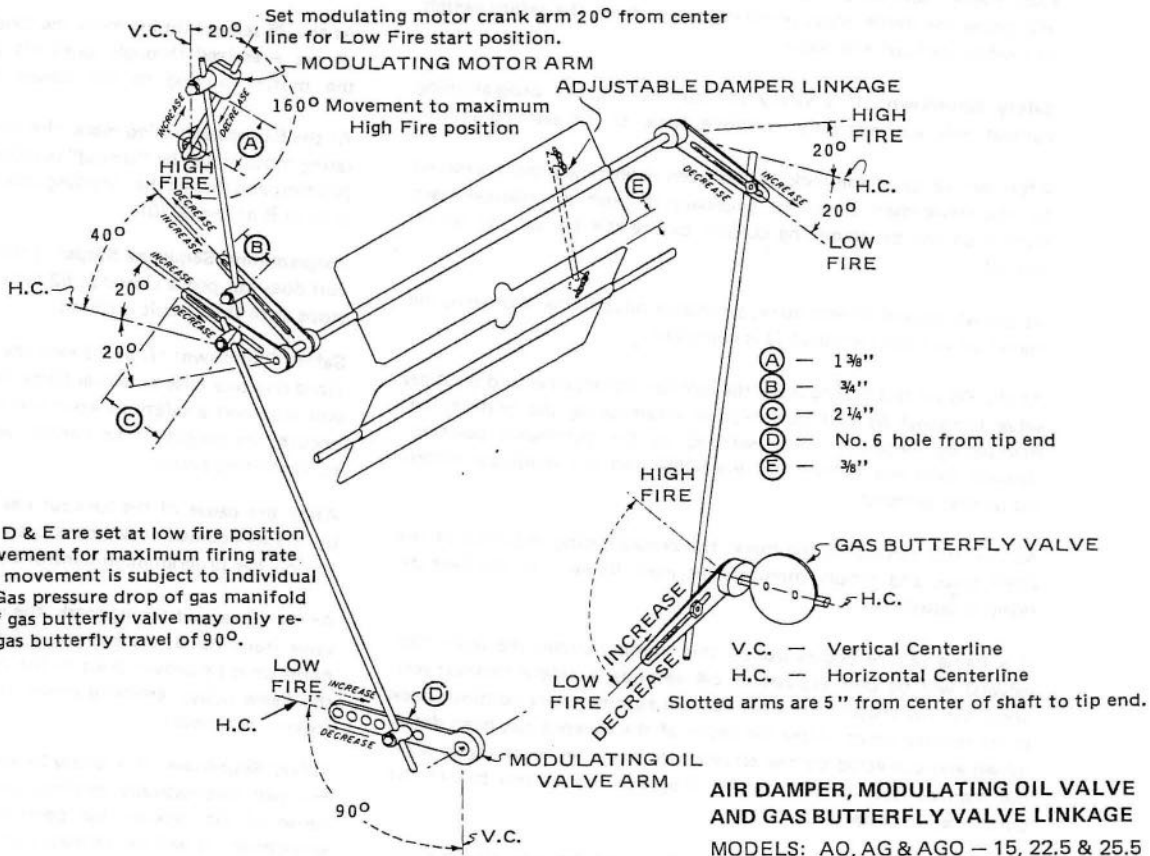

Dimensions A, B, C, D & E are set at low fire position and will give full movement for maximum firing rate on oil. Gas butterfly movement is subject to individual job conditions. e.g. Gas pressure drop of gas manifold used and pipe size of gas butterfly valve may only require 1/2 of the total gas butterfly travel of 90°.

- (A) — 1 3/8"
- (B) — 3/4"
- (C) — 2 1/4"
- (D) — No. 6 hole from tip end
- (E) — 3/8"

V.C. — Vertical Centerline
H.C. — Horizontal Centerline

Slotted arms are 5" from center of shaft to tip end.

AIR DAMPER, MODULATING OIL VALVE AND GAS BUTTERFLY VALVE LINKAGE
MODELS: AO, AG & AGO — 15, 22.5 & 25.5

SK-B-11118-A

FIGURE 34

**OPERATING SEQUENCE OF FIREYE FP2-6058
(Oil, No. 2 or 4 – Modulation)**

The power terminals (2 and 4) of the 6058 are energized continuously. When the operating control "closes" and calls for heat, terminal 3 of the 6058 is energized. (When burning No. 4 oil the cold oil interlock on the heater must be closed at this time and remain closed during the remaining sequence. If this control should open, the unit will recycle and will not start until fuel oil has reached the proper temperature). Providing the low fire end switch on the modulating motor is "closed" proving the closed damper "low fire" position and closing the starting interlock circuit (terminal W to B of the 6058) the fan motor starts and runs for a pre-purge of 35 seconds.

At the 7 second timing mark, the combustion air switch must be "closed", proving air flow and closing the "running interlock" circuit (terminals W to R of the 6058).

Recycle: If the running interlock circuit does not prove closed in 7 seconds, and remain closed during the remaining sequence, the programming control will automatically continue back to its starting point and a recycle will occur.

Safety Shutdown: If, at 24 seconds, the flame relay should be energized due to a false or actual flame signal, the programming sequence will stop and a safety lockout will occur. When the safety lockout occurs the programming control will automatically continue back to its starting point.

After the cause of the lockout has been determined and corrected by the serviceman, it will be necessary to push the manual reset button on the programming control before the burner can be restarted.

At the 35 second timing mark, the ignition transformer and pilot gas valve (terminal 5) are energized. Pilot trial for ignition begins. Pilot flame must be proven prior to the 45 second timing mark, energizing the flame relay, removing power from the safety switch, or a safety lockout will occur.

Safety Shutdown: If a safety lockout occurs, the programming control will automatically continue back to its starting point.

After the cause of the lockout has been determined and corrected by the serviceman, it will be necessary to push the manual reset button on the programming control before the burner can be restarted.

At the 45 second timing mark, providing pilot flame is proven, the main fuel valve(s) (terminal 7) is energized.

At the 60 second timing mark the ignition transformer and pilot gas valve (terminal 5) and de-energized interrupting the ignition. The modulating motor is now switched to the automatic position through terminals 10 to 11 of the 6058) and will modulate according to heat demand.

At the 105 second timing mark, the programming sequence of the 6058 stops and simply monitors the main flame until the heat demand is satisfied.

If a flame failure occurs during this running cycle, the main fuel valve(s) will be de-energized in 2-4 seconds; a safety lockout will occur and the programming control will automatically continue back to its starting point. After the cause of the lockout has been determined and corrected by the serviceman, it will be necessary to push the manual reset button on the programming control before the burner can be restarted.

When the heat demand has been satisfied, and the operating control "opens", the fuel valve(s) is de-energized and the flame is extinguish-

ed. The modulating motor switches from automatic, (terminal 10 to 11 of the 6058) and energizes terminal R to W on the modulating motor to the closed damper "low fire" position. After a 15 second post-purge period, the burner motor stops and the burner is ready for a complete cycle when the operating control again calls for heat.

**OPERATING SEQUENCE OF FIREYE FP2-6070
(Gas, Modulation)**

The power terminals (2 and 4) of the 6070 are energized continuously.

When the operating control "closes" and calls for heat (terminal 3) of the 6070 is energized starting the program sequence. The fan motor starts and runs for an open damper pre-purge.

The modulating motor terminals, R to B, are energized through terminals 10 to 13 of the 6070, starting the motor running to the open damper, "high fire", position.

At the 10 second timing mark, the combustion air switch must be "closed", proving air flow and closing the "running interlock" circuit (terminals 3 to R of the 6070).

Recycle: If the running interlock circuit does not prove closed in 10 seconds, the programming control will automatically continue back to its starting point and a recycle will occur.

At the 20 second timing mark, the high fire end switch on the modulating motor must be "closed" proving the open damper purge and closing the "purge air flow interlock" circuit (terminals 8 to W of the 6070).

Programming Sequence Stops: If the "purge air flow interlock" circuit does not prove closed in 20 seconds, the programming cycle stops until this circuit is closed.

At the 35 second timing mark the modulating motor terminals, R to W, are energized through terminals 10 to 12 of the 6070, starting the motor running to the closed damper, "low fire", position.

At the 53 second timing mark, the low fire end switch on the modulating motor must be "closed" proving the closed damper "low fire" position and closing the "starting ignition interlock" circuit (terminal W to B of the 6070).

Programming Sequence Stops: If the starting ignition interlock circuit does not prove closed at 53 seconds, the programming sequence stops until this circuit is closed.

Safety Shutdown: If, at 53 seconds, the flame relay should be energized due to a false or actual flame signal the programming sequence will stop and a safety lockout will occur. When the safety lockout occurs, the programming control will automatically continue back to its starting point.

After the cause of the lockout has been determined and corrected by the serviceman, it will be necessary to push the manual reset button on the programming control before the burner can be restarted.

At the 63 second timing mark, the ignition transformer and pilot gas valve (terminal 5) are energized. Pilot trial for ignition begins. Pilot flame must be proven prior to the 70 second timing mark, energizing the flame relay, removing power from the safety switch, or a safety lockout will occur.

Safety Shutdown: If a safety lockout occurs, the programming control will automatically continue back to its starting point. After the cause of the lockout has been determined and corrected by the serviceman, it will be necessary to push the manual reset button on the programming control before the burner can be restarted.

At the 75 second timing mark, providing pilot flame is proven, the main fuel valve(s) (terminal 7) is energized. The "running interlock circuit" (terminal 3 to R) must now stay closed or a safety lockout will occur.

At the 90 second timing mark, the ignition transformer and pilot gas valve (terminal 5) are de-energized interrupting the ignition. The modulating motor is now switched to the automatic position (through terminal 10 to 11 of the 6070) and will modulate according to heat demand.

At the 105 second timing mark, the programming sequence of the 6070 stops and simply monitors the main flame until the heat demand is satisfied.

If a flame failure occurs during this running cycle, the main fuel valve(s) will be de-energized in 2-4 seconds; a safety lockout will occur and the programming control will automatically continue back to its starting point. After the cause of the lockout has been determined and corrected by the serviceman, it will be necessary to push the manual reset button on the programming control before the burner can be restarted.

When the heat demand has been satisfied, and the operating control "opens", the fuel valve(s) is de-energized and the flame is extinguished. The modulating motor switches from automatic, (terminal 10 to 11 of the 6070) and energizes terminal R to W on the motor (through terminal 10 to 12 of the 6070) and runs the modulating motor to the closed damper "low fire" position. After a 15 second post-purge period, the burner motor stops and the burner is ready for a complete cycle when the operating control again calls for heat.

OPERATING SEQUENCE OF FIREYE FP2-6070 (Oil No. 6)

The power terminals (2 and 4) of the 6070 are energized continuously.

When the operating control "closes" and calls for heat, providing the cold oil interlock switch on the electric oil pre-heater is closed, (terminal 3) of the 6070 is energized starting the program sequence.

At the 10 second timing mark, the combustion air switch and atomizing air switch must be "closed", proving combustion air and atomizing air flow and closing the "running interlock" circuit (terminals 3 to R of the 6070).

Recycle: If the running interlock circuit does not prove closed in 10 seconds, the programming control will automatically continue back to its starting point and a recycle will occur.

At the 20 second timing mark, the cold oil interlock switch on the burner must be "closed" proving the correct pre-set oil temperature and closing the interlock circuit (terminal 8 to W of the 6070).

Programming Sequence Stops: If the "oil temperature interlock" circuit does not prove closed in 20 seconds, the programming cycle stops until this circuit is closed.

At the 53 second timing mark, the low fire end switch on the modulating motor must be "closed" proving the closed damper "low fire" position and closing the "starting ignition interlock" circuit (terminal W to B of the 6070).

Programming Sequence Stops: If the starting ignition interlock circuit does not prove closed at 53 seconds, the programming sequence stops until this circuit is closed.

Safety Shutdown: If, at 53 seconds, the flame relay should be energized due to a false or actual flame signal the programming sequence

will stop and a safety lockout will occur. When the safety lockout occurs, the programming control will automatically continue back to its starting point.

After the cause of the lockout has been determined and corrected by the serviceman, it will be necessary to push the manual reset button on the programming control before the burner can be restarted.

At the 63 second timing mark, the ignition transformer and pilot gas valve (terminal 6) are energized. Pilot trial for ignition begins. Pilot flame must be proven prior to the 70 second timing mark, energizing the flame relay, removing power from the safety switch, or a safety lockout will occur.

Safety Shutdown: If a safety lockout occurs, the programming control will automatically continue back to its starting point. After the cause of the lockout has been determined and corrected by the serviceman, it will be necessary to push the manual reset button on the programming control before the burner can be restarted.

At the 75 second timing mark, providing pilot flame is proven, the main fuel valve(s) (terminal 7) is energized. The "running interlock circuit" (terminal 3 to R) must now stay closed or a safety lockout will occur.

At the 90 second timing mark, the modulating motor is now switched to the automatic position (through terminal 10 to 11 of the 6070) and will modulate according to heat demand.

At the 105 second mark, the ignition transformer and pilot gas valve (terminal 6) are de-energized, interrupting the ignition. The programming sequence of the 6070 stops and simply monitors the main flame until the heat demand is satisfied.

If a flame failure occurs during this running cycle, the main fuel valve(s) will be de-energized in 2-4 seconds; a safety lockout will occur and the programming control will automatically continue back to its starting point. After the cause of the lockout has been determined and corrected by the serviceman, it will be necessary to push the manual reset button on the programming control before the burner can be restarted.

When the heat demand has been satisfied, and the operating control "opens", the fuel valve(s) is de-energized and the flame is extinguished. The modulating motor switches from automatic, (terminal 10 to 11 of the 6070) and energizes terminal R to W on the motor (through terminal 10 to 12 of the 6070) and runs the modulating motor to the closed damper "low fire" position. After a 15 second post-purge period, the burner motor stops and the burner is ready for a complete cycle when the operating control again calls for heat.

OPERATING SEQUENCE OF FIREYE FP2-6080 (Gas/Oil, Modulation - F.M.)

The power terminals (2 and 4) of the 6080 are energized continuously.

When the operating control "closes" and calls for heat, terminal 3 of the 6080 is energized. The fuel valve interlock circuit (terminals 3 to FV) must now be closed, (normally a jumper is used on units under 12,500 MBH) energizing terminal FV and starting the program sequence. The fan motor starts and runs for an open damper pre-purge.

The modulating motor terminals, R to B, are energized through terminals 10 to 13 of the 6080, starting the motor running to the open damper, "high fire" position.

The high fire end switch on the modulating motor must "close" proving the open damper purge and closing the "purge air flow interlock" circuit (terminals 8 to W) before the programming sequence starts.

At the 8 second timing mark, the combustion air switch must be "closed" proving air flow and closing the "non-recycling interlock" circuit (terminals FV to R) of the 6080 for the programming sequence to continue.

The "non-recycling interlock" circuit must now stay closed or a safety lockout will occur.

Safety Shutdown: If a safety lockout occurs, the programming control will automatically continue back to its starting point. After the cause of the lockout has been determined and corrected by the serviceman, it will be necessary to push the manual reset button on the programming control before the burner can be restarted.

At the 30 second timing mark, the modulating motor terminals R to W are energized (through terminals 10 to 12 of the 6080) and start the motor running to the closed damper, "low fire", position.

At the 35 second timing mark, the low fire end switch on the modulating motor must be "closed" proving the closed damper "low fire" position and closing the "low fire ignition interlock" circuit (terminal W to B of the 6080).

Programming Sequence Stops: If the "low fire ignition interlock" circuit does not prove closed at 35 seconds the programming sequence stops until this circuit is closed.

Safety Shutdown: If at any time during the above sequence, the flame relay should be energized due to a false or actual flame signal, the programming sequence will stop and a safety lockout will occur. When the safety lockout occurs, the programming control will automatically continue back to its starting point.

After the cause of the lockout has been determined and corrected by the serviceman, it will be necessary to push the manual reset button on the programming control before the burner can be restarted.

At the 45 second timing mark, the ignition transformer and pilot gas valve (terminal 5) are energized. Pilot trial for ignition begins. Pilot flame must be proven prior to the 55 second timing mark, energizing the flame relay, removing power from the safety switch, or a safety lockout will occur.

At the 55 second timing mark, the main full valve(s) (terminal 7) is energized.

At the 65 second timing mark, the ignition transformer and pilot gas valve (terminal 5) are de-energized, interrupting the ignition.

At the 70 second timing mark, the modulating motor is now switched to the automatic position (through terminal 10 to 11 of the 6080) and will modulate according to heat demand.

At the 85 second timing mark, the programming sequence of the 6080 stops and simply monitors the main flame until the heat demand is satisfied.

If a flame failure occurs during this running cycle, the main fuel valve(s) will be de-energized in 2 - 4 seconds; a safety lockout will occur and the programming control will automatically continue back to its starting point. After the cause of the lockout has been determined and corrected by the serviceman, it will be necessary to push the manual reset button on the programming control before the burner can be restarted.

When the heat demand has been satisfied and the operating control "opens", the fuel valve(s) is de-energized and the flame is extinguished. The modulating motor switches from automatic (terminal 10 to 11 of the 6080) and energized terminal R to W on the motor (through terminal 10 to 12 of the 6080) and runs the modulating motor to the closed damper "low fire" position. After a 20 second post-purge period, the burner motor stops, and the burner is ready for a complete cycle when the operating control again calls for heat.

WIRING

All building wiring must be done in accordance with National Code and/or in accordance with local requirements and insurances which may apply. The wiring and controls furnished with the burner are pre-tested at the factory. It is recommended that all wiring be run in rigid conduit, but that a piece of flexible conduit be used between the rigid conduit and the control box on the burner to make possible the removing of burner for inspection without disconnecting any wiring.

The wire insulation should be rated at not less than 600 volts and listed by Underwriters' Laboratories, Inc. for the ambient temperature in which the wiring is installed.

There should be separate approved fused disconnect switches or circuit breakers of the proper capacity for all motors and electric oil pre-heaters.

A wiring diagram is included with the burner that illustrates the control arrangement and wiring for this specific burner. Use same and wire into the burner accordingly. (Typical wiring diagrams are included elsewhere in this manual).

Normally, the motor(s) furnished with burner includes a motor starter or relay; included is overload protection.

Motor voltages and phasing differ depending on job requirements; refer to copy of the order included with burner to determine correct motor voltage and phase. All controls and control circuits are 115 volts, and a control circuit transformer is furnished when motor voltage differs from 115 volts.

Normally it is only necessary to bring power to the burner; all components on the burner are factory wired, except gas piping groups and when applicable, separate oil pump sets and air compressors. Refer to "Pre-Start-Up Procedure" before attempting to light burner.

30" PANEL

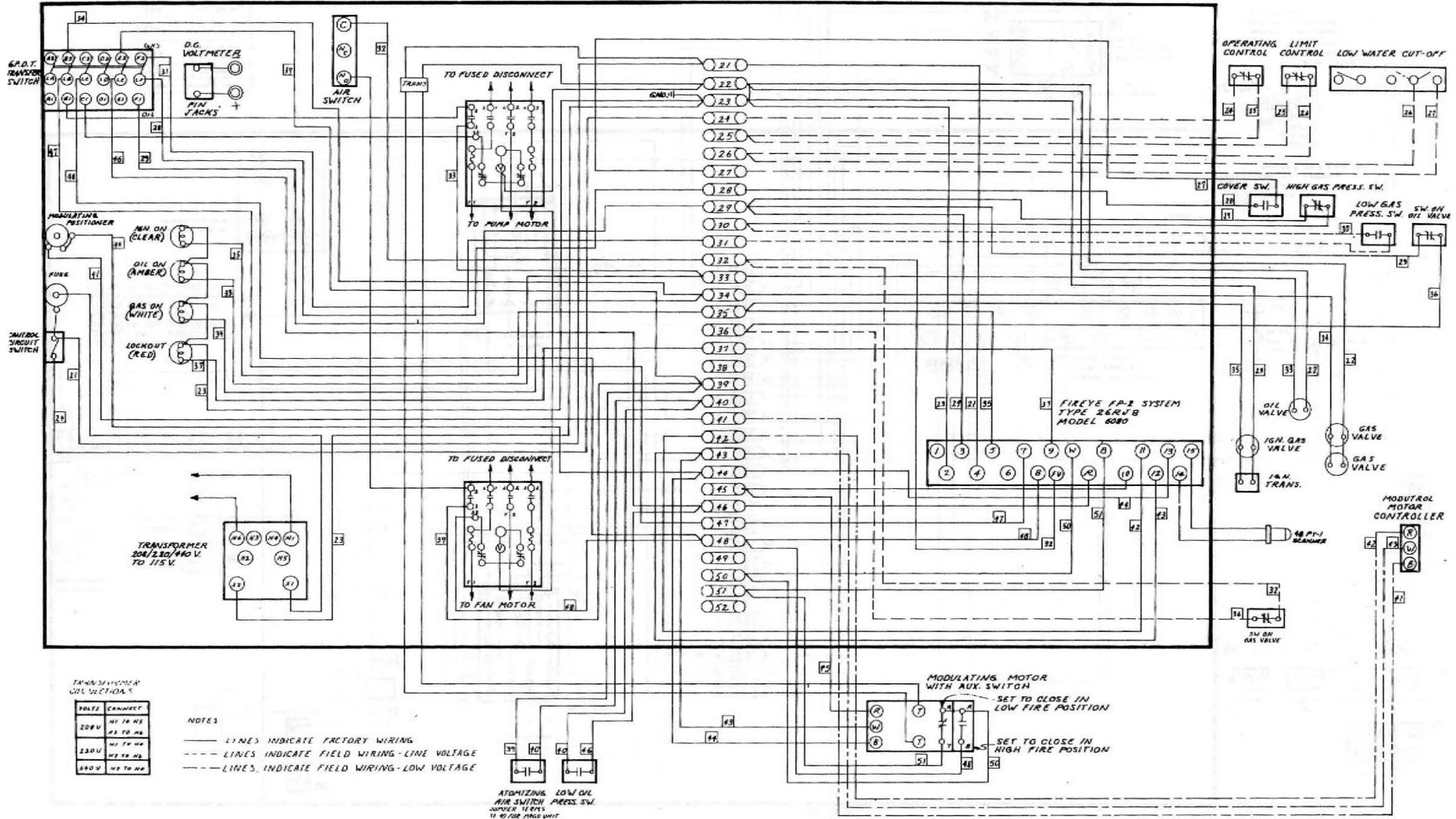

ATOMIZER 2 OIL F. M.
AGO - 2 - 15, 22.5 or 25.5
PAGO - 2 - 15

WD-D-28370

30" PANEL

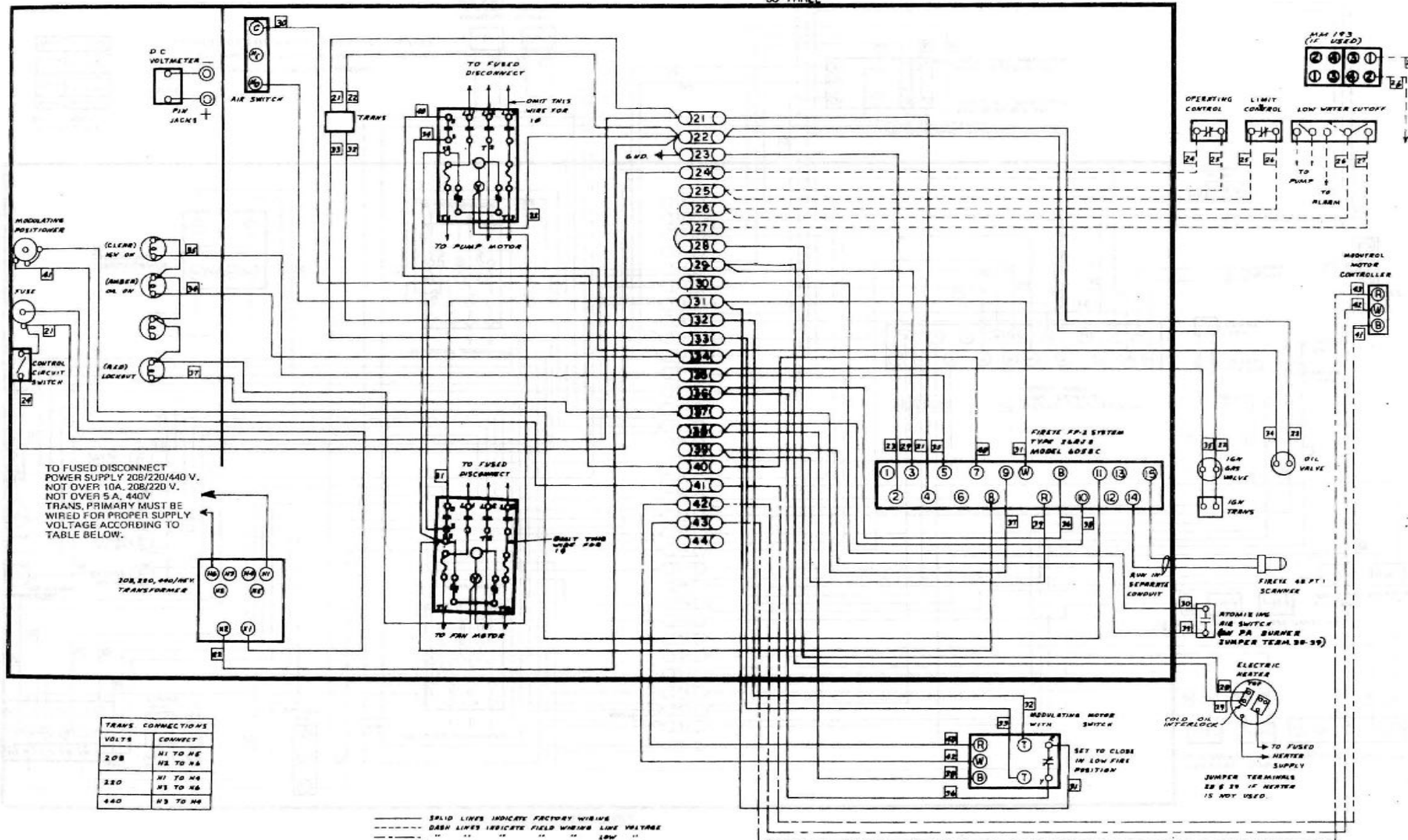

ATOMIZER AO-PAO
UL 2 OR 4 OIL
AO - 4.5
PAO - 2.1 OR 4.5 "/EXT. PUMP

WD-D-26272

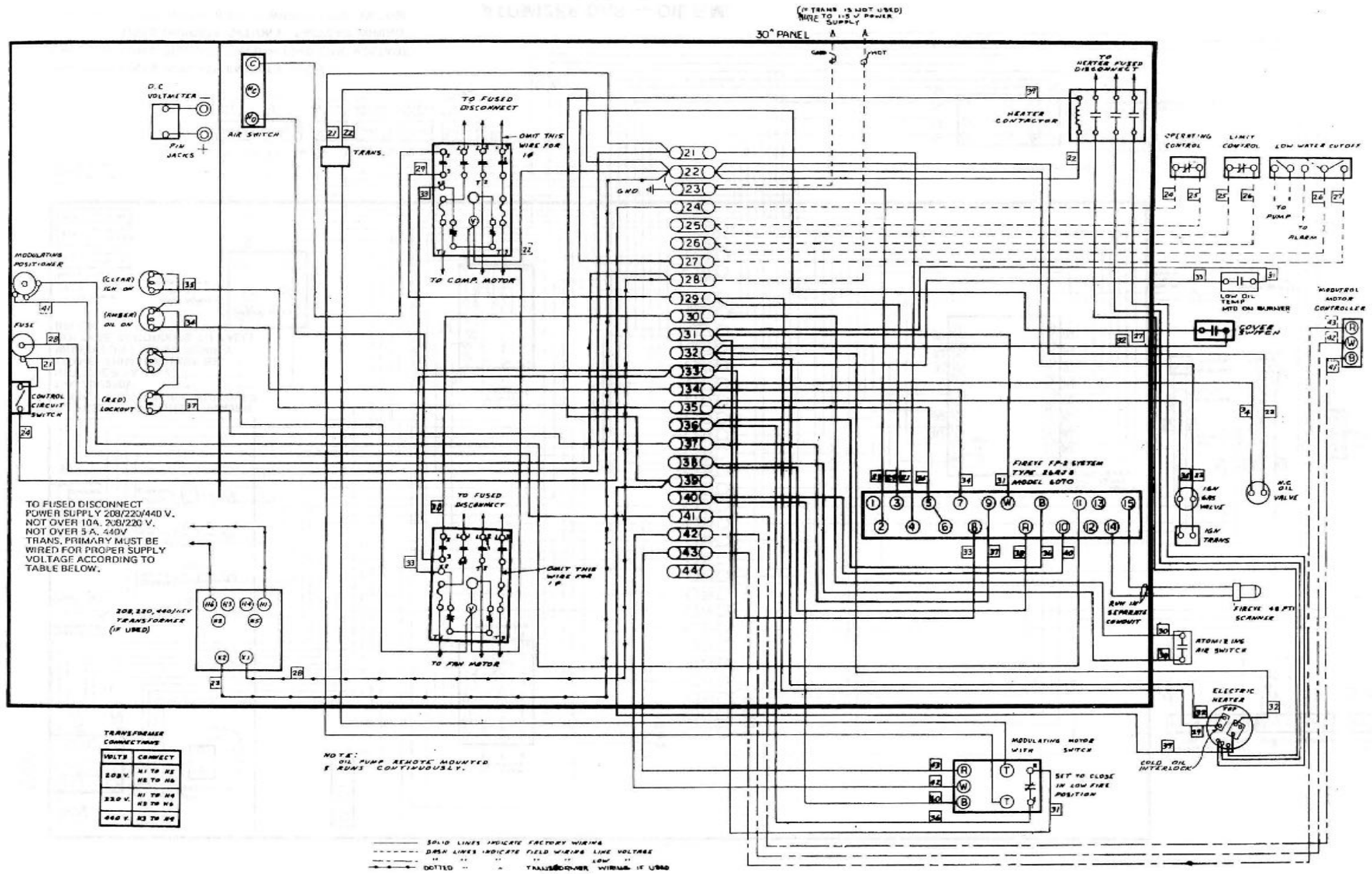

AIR ATOMIZER - OIL
AO 6 - 9.8 - 15 - 22.5
OR 25.5.

WD-D-26277A

30 PANEL

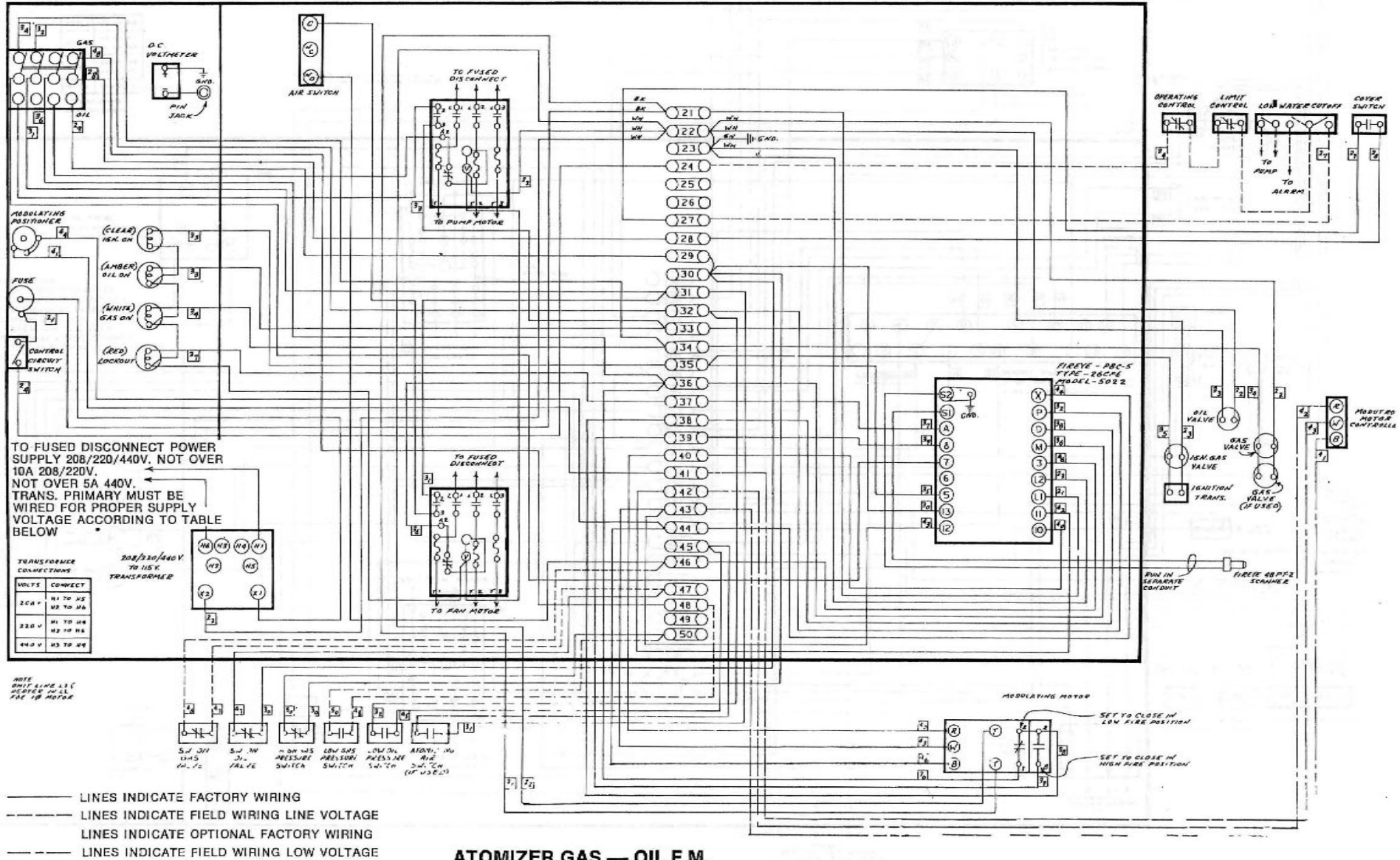

TO FUSED DISCONNECT POWER SUPPLY 208/220/440V. NOT OVER 10A 208/220V. NOT OVER 5A 440V. TRANS. PRIMARY MUST BE WIRED FOR PROPER SUPPLY VOLTAGE ACCORDING TO TABLE BELOW

TRANSFORMER CONNECTIONS

VOLTS	CONNECT
208 V	H1 TO H2 H3 TO H4
220 V	H1 TO H4 H2 TO H3
440 V	H3 TO H4

208/220/440V TO 115 V TRANSFORMER

NOTE: WHITE LINE IS C HEATER IN ALL THE 10 MOTOR

ATOMIZER GAS — OIL F.M.
PAGO-2-15
AG0-2-15, 22.5 OR 25.5

WD-D-28599

30" PANEL

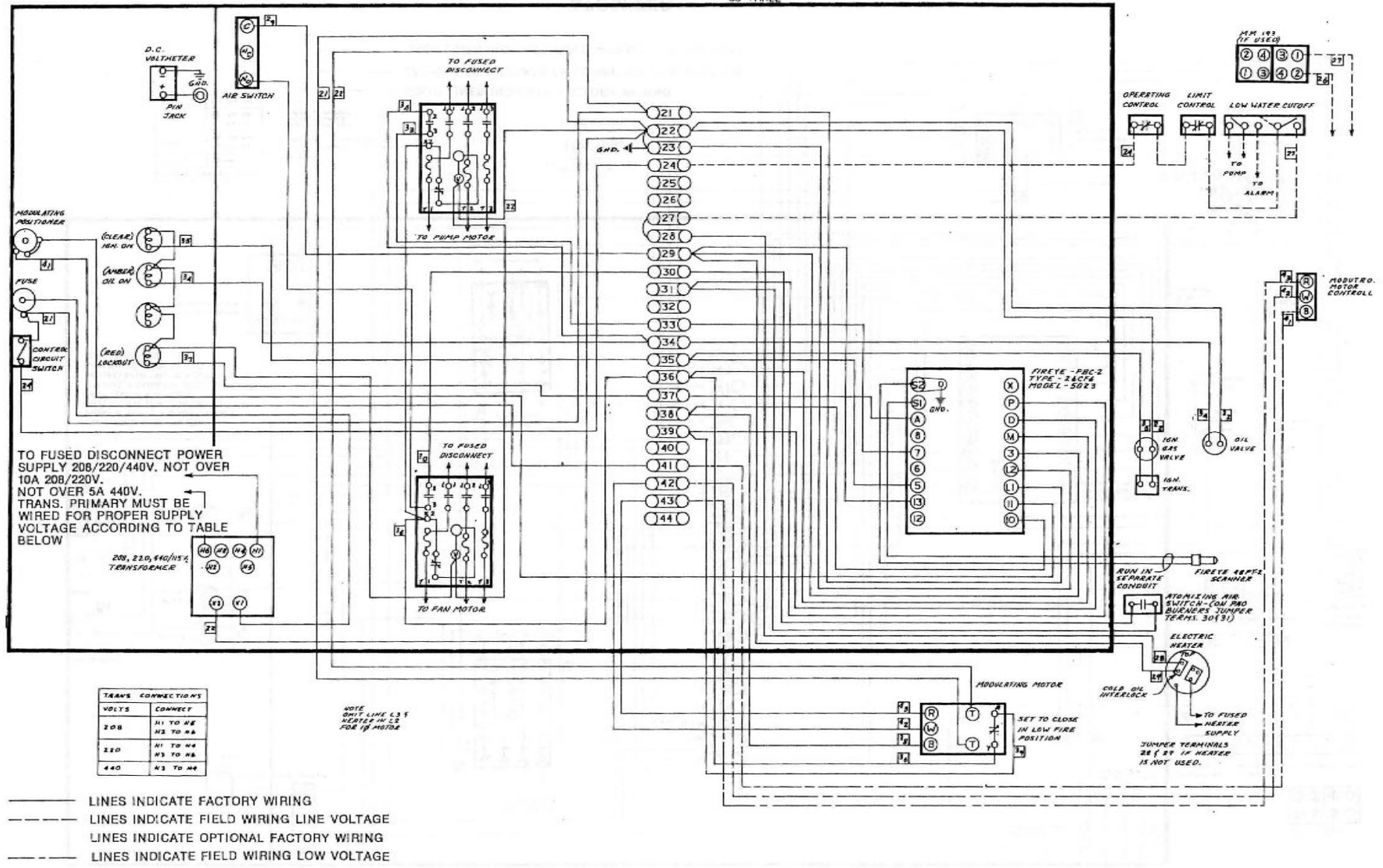

TO FUSED DISCONNECT POWER SUPPLY 208/220/440V. NOT OVER 10A 208/220V. NOT OVER 5A 440V. TRANS. PRIMARY MUST BE WIRED FOR PROPER SUPPLY VOLTAGE ACCORDING TO TABLE BELOW

TRANS CONNECTIONS	
VOLTS	CONNECT
208	N1 TO N4 N2 TO N6
220	N1 TO N4 N3 TO N6
440	N3 TO N6

NOTE
OMIT LINE L3 &
WIRE IN L1, L2
FOR 1Ø MOTOR

- LINES INDICATE FACTORY WIRING
- - - LINES INDICATE FIELD WIRING LINE VOLTAGE
- · · LINES INDICATE OPTIONAL FACTORY WIRING
- · - LINES INDICATE FIELD WIRING LOW VOLTAGE

**ATOMIZER — #2 OR #4 OIL U.L.
AO-2 OR 4-4.5
PAO-2 OR 4-2.1 OR 4.5 W/EX. PUMP**

WD-D-26589

30" PANEL

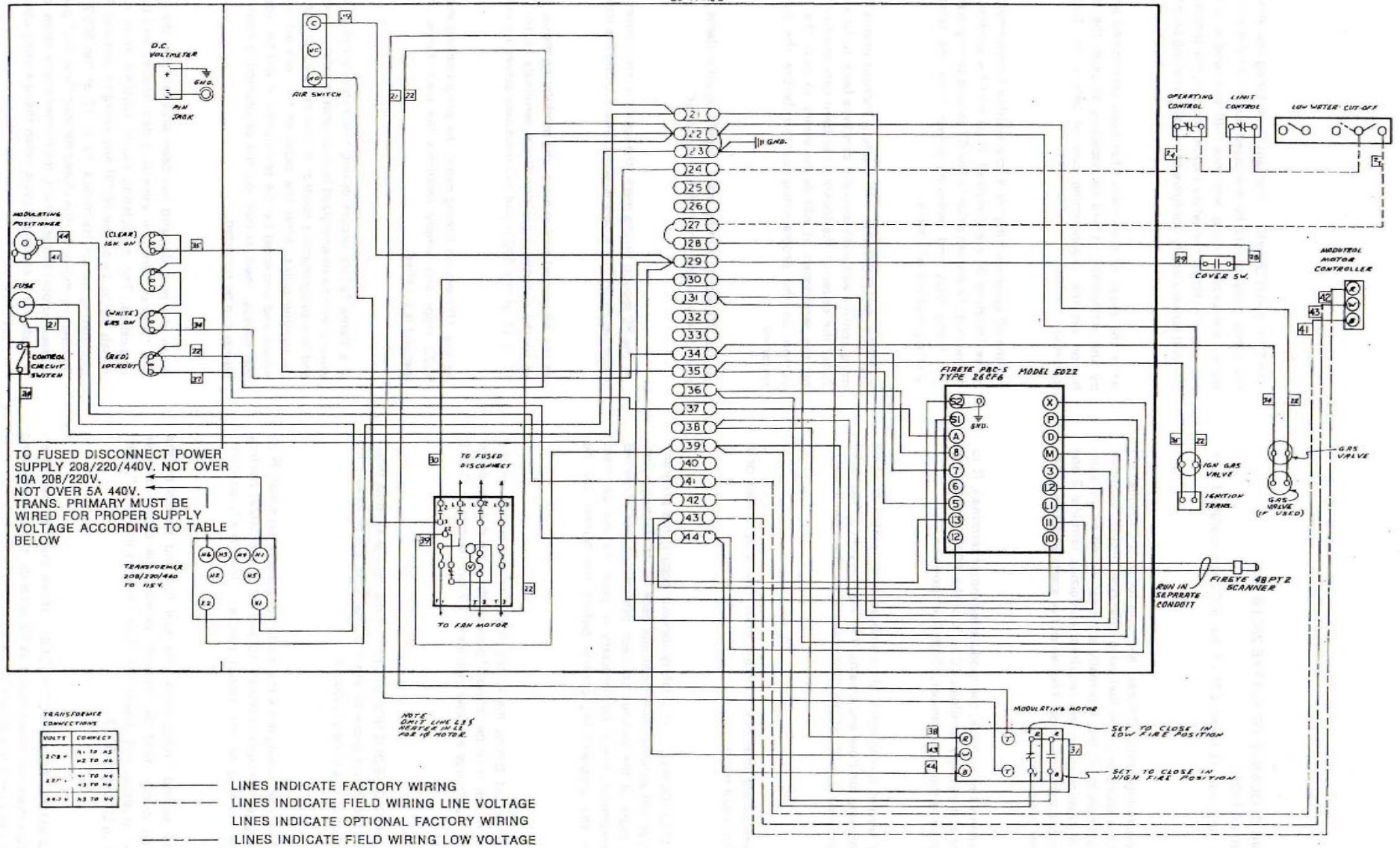

**AIR ATOMIZER GAS U.L.
 AG-6.3, 9.8, 15, 22.5 OR 25.5**

WD-D-27134

**OPERATING SEQUENCE OF FIREYE 26CF6-5022
(GAS-MODULATION)**

The power terminals (L1 and L2) of the 5022 are energized continuously.

When the operating control "closes" and calls for heat (terminal 13) of the 5022 is energized. The fuel valve interlock circuit (terminals 13 to 3) must now be closed, (normally a jumper is used on units unless proof-of-closure valves are required) energizing terminal 3 and starting the program sequence. The fan motor starts and runs for an open damper pre-purge.

At the 3 second timing mark, the modulating motor terminals, R to B, are energized through terminals 10 to X of the 5022, starting the motor running to the open damper, "high fire" position.

At the 17 second timing mark, the combustion air switch must be "closed" proving air flow and closing the "non-recycling interlock" circuit (terminals 3 to P) of the 5022 for the program sequence to continue.

The "non-recycling interlock" circuit must now stay closed or a safety lockout will occur.

SAFETY SHUTDOWN: If a safety lockout occurs, the programming control will automatically continue back to its starting point. After the cause of the lockout has been determined and corrected by the serviceman, it will be necessary to push the manual reset button on the programming control before the burner can be restarted.

At the 22 second timing mark, the high fire end switch on the modulating motor must be "closed" proving the open damper purge and closing the "purge air flow interlock" circuit (terminals D to 8 of the 5022).

PROGRAMMING SEQUENCE STOPS: If the "purge air flow interlock" circuit does not prove closed in 22 seconds, the programming cycle stops until this circuit is closed.

At the 33 second timing mark the modulating motor terminals R to W are energized through terminals 10 and 12 of the 5022, starting the motor running to the closed damper "low fire", position.

At the 53 second timing mark, the low fire end switch on the modulating motor must be "closed" proving the closed damper "low fire" position and closing the "low fire start interlock", (terminals M to D) of the 5022.

PROGRAMMING SEQUENCE STOPS: If the low fire start interlock circuit does not prove closed at 53 seconds, the programming sequence stops until this circuit is closed.

SAFETY SHUTDOWN: If at anytime during the above sequence the flame relay should be energized due to a false or actual flame signal, the programming sequence will stop and a safety lockout will occur — When the safety lockout occurs, the programming control will automatically continue back to its starting point.

After the cause of the lockout has been determined and corrected by the serviceman, it will be necessary to push the manual reset button on the programming control before the burner can be restarted.

At the 60 second timing mark, the ignition transformer and pilot gas valve (terminal 5) are energized. Pilot trial for ignition begins. Pilot flame must be proven prior to the 67 second timing mark, energizing the flame relay and removing power from the safety switch, or a safety lockout will occur.

SAFETY SHUTDOWN: If a safety lockout occurs the programming control will automatically continue back to its starting point. After the cause of the lockout has been determined and corrected by the serviceman, it will be necessary to push the manual reset button on the programming control before the burner can be restarted.

At the 70 second timing mark, providing pilot flame is proven, the main fuel valve(s), terminal 7, is energized.

At the 80 second timing mark, the ignition transformer and pilot gas valve (terminal 5) are de-energized, interrupting the ignition.

At the 85 second timing mark, the modulating motor is now switched to the automatic position (from terminals 10 to 12 to terminal 10 to 11 of the 5022) and will modulate according to heat demand.

At the 100 second timing mark, the programming sequence of the 5022 stops and simply monitors the main flame until the heat demand is satisfied.

If a flame failure occurs during this running cycle, the main fuel valve(s) will be de-energized in 2 seconds; a safety lockout will occur and the programming control will automatically continue back to its starting point. After the cause of the lockout has been determined and corrected by the serviceman, it will be necessary to push the manual reset button on the programming control before the burner can be restarted.

When the heat demand has been satisfied and the operating control "opens", the fuel valve(s) is de-energized and the flame is extinguished. The modulating motor switches from automatic (terminals 10 to 11 of the 5022) and energize terminal R to W on the modulating motor (terminals 10 to 12 of the 5022) and run modulating motor to the closed damper "low fire" position. At 20 second post-purge period, the burner motor stops, and the burner is ready for a complete cycle when the operating control again calls for heat.

OPERATING SEQUENCE OF FIREYE 26CF6-5023 (Oil No. 6)

The power terminals (L1 and L2) of the 5023 are energized continuously.

When the operating control "closes" and calls for heat, providing the cold oil interlock switch on the electric oil pre-heater is closed, terminals 13 of the 5023 is energized. The fuel valve interlock circuit (terminals 13 to 3) must now be closed, (normally a jumper is used on units unless proof-of-closure valves are required) energizing terminal 3 and starting the program sequence — (The cold oil interlock on the heater must be closed at this time and remain closed during the remaining sequence. If this control should open, the unit will recycle and will not start until the fuel oil has reached the proper temperature). The fan motor starts and runs for a pre-purge of 60 seconds.

At the 14 second timing mark, the combustion air switch must be "closed", proving air flow and closing the "running interlock" circuit (terminals 3 to P of the 5023).

RECYCLE: If the running interlock does not prove closed in 14 seconds, and remain closed during the remaining sequence, the programming control will automatically continue back to its starting point and a recycle will occur.

SAFETY SHUTDOWN: If during the pre-purge, the flame relay should be energized due to a false or actual flame signal, a safety lockout will occur. When the safety lockout occurs the programming control will automatically continue back to its starting point.

After the cause of the lockout has been determined and corrected by the serviceman, it will be necessary to push the manual reset button on the programming control before the burner can be restarted.

At the 53 second timing mark, the low fire end switch on the modulating motor must be "closed" proving the closed damper "low fire" position and the cold oil interlock switch on the burner must be "closed" proving the correct pre-set oil temperature and closing the starting interlock circuit (terminals M to D of the 5023) or the program sequence will stop until this circuit is closed.

At the 60 second timing mark, the ignition transformer and pilot gas valve (terminal 5) are energized. Pilot trial for ignition begins. Pilot flame must be proven prior to the 67 second timing mark which energizes the flame relay and removes power from the safety switch, or a safety lockout will occur.

SAFETY SHUTDOWN: If a safety lockout occurs the programming control will automatically continue back to its starting point.

After the cause of the lockout has been determined and corrected by the serviceman, it will be necessary to push the manual reset button on the programming control before the burner can be restarted.

At the 70 second timing mark, providing pilot flame is proven, the main fuel valve(s) (terminal 7) is energized.

At the 80 second timing mark, the ignition transformer and pilot gas valve(s) (terminal 5) are de-energized interrupting the ignition.

At the 85 second timing mark, the modulating motor is now switched to the automatic position. Terminals 10 to 12 open and terminals 10 to 11 of the 5023 close and modulation occurs according to heat demand.

At the 105 second timing mark, the programming sequence of the 5023 stops and simply monitors the main flame until the heat demand is satisfied.

If a flame failure occurs during this running cycle, the main fuel valve(s) will be de-energized in 2 seconds; a safety lockout will occur and the programming control will automatically continue back to its starting point. After the cause of the lockout has been determined and corrected by the serviceman, it will be necessary to push the manual reset button on the programming control before the burner can be restarted.

When the heat demand has been satisfied, and the operating control "opens", the fuel valve(s) is de-energized and the flame is extinguished. The modulating motor switches from automatic (terminals 10 to 11 of the 5023 to terminals 10 to 12) energizing terminals R to W on the modulating motor returning the motor to the closed damper "low fire" position. After a 15 second post-purge period, the burner motor stops and the burner is ready for a complete cycle when the operating control again calls for heat.

**OPERATING SEQUENCE OF FIREYE 26CF6-5022
GAS/OIL, MODULATION — F.M.**

The power terminals (L1 and L2) of the 5022 are energized continuously.

When the operating control "closes" and calls for heat (terminal 13) of the 5022 is energized. The fuel valve interlock circuit (terminals 13 to 3) must now be closed, (normally a jumper is used on units unless proof-of-closure valves are required) energizing terminal 3 and starting the program sequence. The fan motor starts and runs for an open damper pre-purge.

At the 3 second timing mark, the modulating motor terminals, R to B, are energized through terminals 10 to X of the 5022, starting the motor running to the open damper, "high fire" position.

At the 17 second timing mark, the combustion air switch must be "closed" proving air flow and closing the "non-recycling interlock" circuit (terminals 3 to P) of the 5022 for the program sequence to continue.

The "non-recycling interlock" circuit must now stay closed or a safety lockout will occur.

SAFETY SHUTDOWN: If a safety lockout occurs, the programming control will automatically continue back to its starting point. After the cause of the lockout has been determined and corrected by the serviceman, it will be necessary to push the manual reset button on the programming control before the burner can be restarted.

At the 22 second timing mark, the high fire end switch on the modulating motor must be "closed" proving the open damper purge and closing the "purge air flow interlock" circuit (terminals D to 8 of the 5022).

PROGRAMMING SEQUENCE STOPS: If the "purge air flow interlock" circuit does not prove closed in 22 seconds, the programming cycle stops until this circuit is closed.

At the 33 second timing mark the modulating motor terminals R to W are energized through terminals 10 and 12 of the 5022, starting the motor running to the closed damper "Low fire", position.

At the 53 second timing mark, the low fire end switch on the modulating motor must be "closed" proving the closed damper "low fire" position and closing the "low fire start interlock", (terminals M to D) of the 5022.

PROGRAMMING SEQUENCE STOPS: If the low fire start interlock circuit does not prove closed at 53 seconds, the programming sequence stops until this circuit is closed.

SAFETY SHUTDOWN: If at anytime during the above sequence the flame relay should be energized due to a false or actual flame signal, the programming sequence will stop and a safety lockout will occur — When the safety lockout occurs, the programming control will automatically continue back to its starting point.

After the cause of the lockout has been determined and corrected by the serviceman, it will be necessary to push the manual reset button on the programming control before the burner can be restarted.

At the 60 second timing mark, the ignition transformer and pilot gas valve (terminal 5) are energized. Pilot trial for ignition begins. Pilot flame must be proven prior to the 67 seconds energizing the flame relay and removing power from the safety switch, or a safety lockout will occur.

SAFETY SHUTDOWN: If a safety lockout occurs the programming control will automatically continue back to its starting point. After the cause of the lockout has been determined and corrected by the serviceman, it will be necessary to push the manual reset button on the programming control before the burner can be restarted.

At the 70 second timing mark, providing pilot flame is proven, the main fuel valve(s) (terminal 7) is energized.

At the 80 second timing mark, the ignition transformer and pilot valve (terminal 5) are de-energized, interrupting the ignition.

At the 85 second timing mark, the modulating motor is now switched to the automatic position (from terminals 10 to 12 to terminals 10 to 11 of the 5022) and will modulate according to heat demand.

At the 100 second timing mark, the programming sequence of the 5022 stops and simply monitors the main flame until the heat demand is satisfied.

If a flame failure occurs during this running cycle, the main fuel valve(s) will be de-energized in 2 seconds; a safety lockout will occur and the programming control will automatically continue back to its starting point. After the cause of the lockout has been determined and corrected by the serviceman, it will be necessary to push the manual reset button on the programming control before the burner can be restarted.

When the heat demand has been satisfied and the operating control "opens", the fuel valve(s) is de-energized and the flame is extinguished. The modulating motor switches from automatic (terminals 10 to 11 of the 5022) and energize terminal R to W on the modulating motor (terminals 10 to 12 of the 5022) and runs the modulating motor to the closed damper "low fire" position. After a 20 second post-purge period, the burner motor stops, and the burner is ready for a complete cycle when the operating control calls for heat.

OPERATING SEQUENCE OF FIREYE 26CF6-5023 CONTROL (Oil No. 2 or 4 – MODULATION)

The power terminals (L1 and L2) of the 5023 are energized continuously. When the operating control "closes" and calls for heat, terminal 13 of the 5023 is energized. The fuel valve interlock circuit (terminals 13 to 3) must now be closed, (normally a jumper is used unless proof-of-closure valves are required) energizing terminal 3 and starting the program sequence). (When burning No. 4 oil the cold oil interlock on the heater must be closed at this time and remain closed during the remaining sequence. If this control should open, the unit will recycle and will not start until the fuel oil has reached the proper temperature). The fan motor starts and runs for a pre-purge of 60 seconds.

At the 14 second timing mark, the combustion air switch must be "closed", proving air flow and closing the "running interlock" circuit (terminals 3 to P of the 5023).

RECYCLE: If the running interlock does not prove closed in 14 seconds, and remain closed during the remaining sequence, the programming control will automatically continue back to its starting point and a recycle will occur.

SAFETY SHUTDOWN: If during the pre-purge, the flame relay should be energized due to a false or actual flame signal, a safety lockout will occur. When the safety lockout occurs the programming control will automatically continue back to its starting point.

After the cause of the lockout has been determined and corrected by the serviceman, it will be necessary to push the manual reset button on the programming control before the burner can be restarted.

At the 53 second timing mark, the low fire end switch on the modulating motor must be "closed" proving the closed damper "low fire" position and closing the starting interlock circuit (terminals M to D of the 5023) or the program sequence will stop until this circuit is closed.

At the 60 second timing mark, the ignition transformer and pilot gas valve (terminal 5) are energized. Pilot trial for ignition begins. Pilot flame must be proven prior to the 67 second timing mark, energizing the flame relay, removing power from the safety switch, or a safety lockout will occur.

SAFETY SHUTDOWN: If a safety lockout occurs the programming control will automatically continue back to its starting point.

After the cause of the lockout has been determined and corrected by the serviceman, it will be necessary to push the manual reset button on the programming control before the burner can be restarted.

At the 70 second timing mark, providing pilot flame is proven, the main fuel valve(s) (terminal 7) is energized.

At the 80 second timing mark, the ignition transformer and pilot gas valve (terminal 5) are de-energized interrupting the ignition.

At the 85 timing mark, the modulating motor is now switched to the automatic position. Terminals 10 to 12 open and terminals 10 to 11 of the 5023 close and modulation occurs according to heat demand.

At the 105 second timing mark, the programming sequence of the 5023 stops and simply monitors the main flame until the heat demand is satisfied.

If a flame failure occurs during the running cycle, the main fuel valve(s) will be de-energized in 2 seconds; a safety lockout will occur and the programming control will automatically continue back to its starting point. After the cause of the lockout has been determined and corrected by the serviceman, it will be necessary to push the manual reset button on the programming control before the burner can be restarted.

When the heat demand has been satisfied, and the operating control "opens", the fuel valve(s) is de-energized and the flame is extinguished. The modulating motor switches from automatic (terminals 10 to 11 of the 5023 to terminals 10 to 12) energizing terminals R to W on the modulating motor returning the motor to the closed damper "low fire" position. After a 15 second post-purge period, the burner motor stops and the burner is ready for a complete cycle when the operating control again calls for heat.

WIRING

All building wiring must be done in accordance with National Code and/or in accordance with local requirements and insurances which may apply. The wiring and controls furnished with the burner are pre-tested at the factory. It is recommended that all wiring be run in rigid conduit, but that a piece of flexible conduit be used between the rigid conduit and the control box on the burner to make possible the removing of burner for inspection without disconnecting any wiring.

The wire insulation should be rated at not less than 600 volts and listed by Underwriters' Laboratories, Inc. for the ambient temperature in which the wiring is installed.

There should be separate approved fused disconnect switches or circuit breakers of the proper capacity for all motors and electric oil pre-heaters.

A wiring diagram is included with the burner that illustrates the control arrangement and wiring for this specific burner. Use same and wire into the burner accordingly. (Typical wiring diagrams are included elsewhere in this manual).

Normally, the motor(s) furnished with burner includes a motor starter or relay; included is overload protection.

Motor voltages and phasing differ depending on job requirements; refer to copy of the order included with burner to determine correct motor voltage and phase. All controls and control circuits are 115 volts, and a control circuit transformer is furnished when motor voltage differs from 115 volts.

Normally it is only necessary to bring power to the burner; all components on the burner are factory wired, except gas piping groups and when applicable, separate oil pump sets and air compressors. Refer to "Pre-Start-Up Procedure" before attempting to light burner.

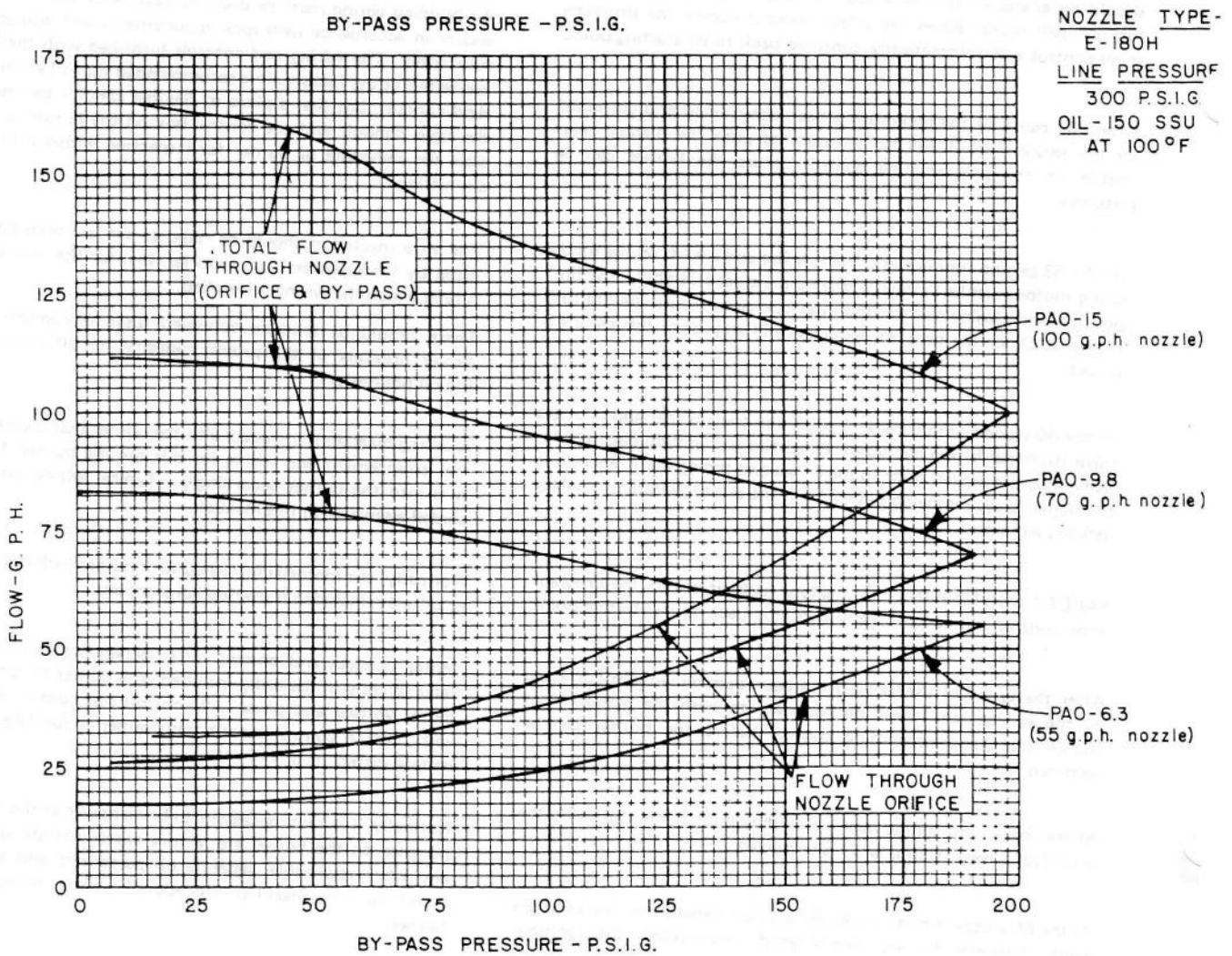
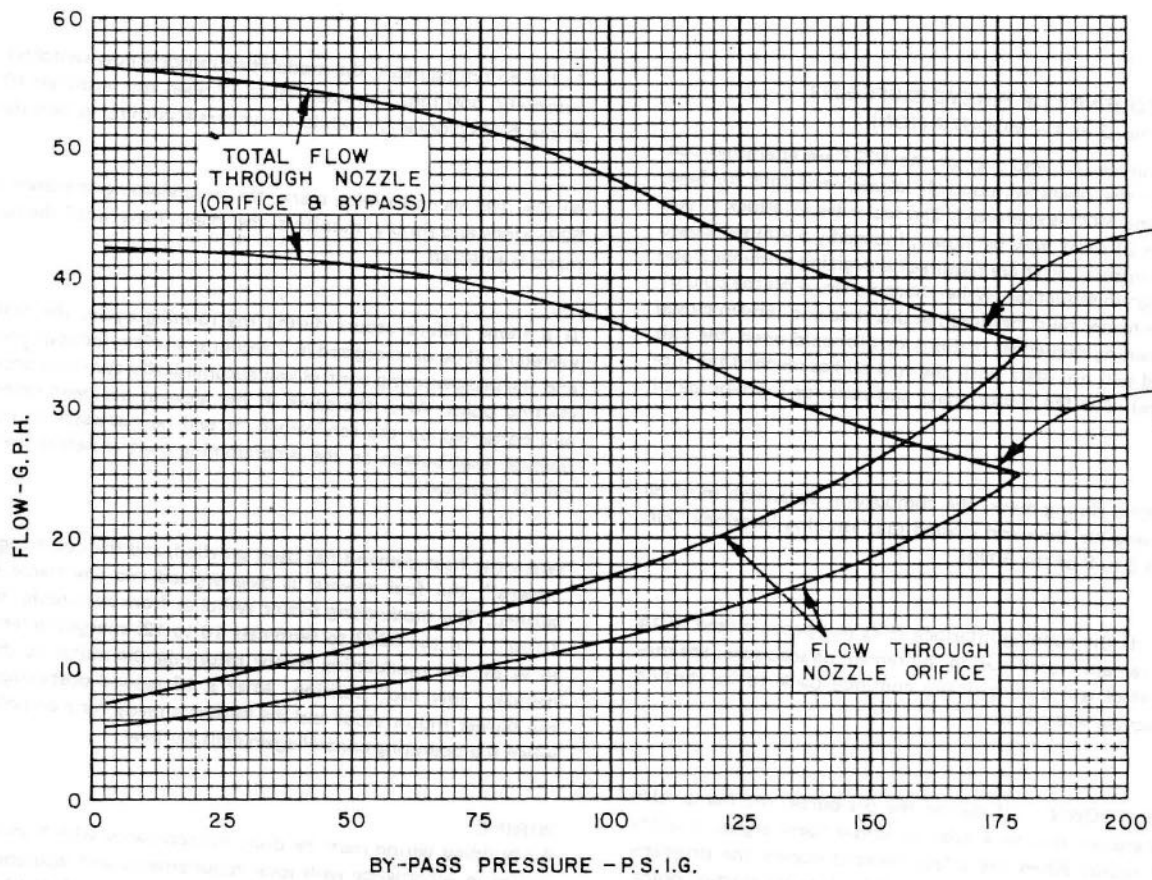

APPROXIMATE AC MOTORS AMPS

Motor Amps will vary depending on the type and manufacture of the motor. These tables below are average values to be used only as a guide. The formulas at the bottom of the page may be used to obtain approximate amps for 2 phase systems and other frequencies.

NOTE: Actual Motor Amps may be higher or lower than the values listed below for a particular motor. For more effective motor protection select heater elements by using the motor nameplate amps.

SINGLE PHASE

HP	AMPERES 60 Hz		
	SPEED RPM	115 Volts	230 Volts
1/4	3600	3.9	1.9
	1800	4.4	2.2
	1200	5.8	2.9
	900	7.1	3.6
1/3	3600	4.5	2.3
	1800	5.1	2.5
	1200	6.2	3.1
	900	7.4	3.7
1/2	3600	6.4	3.2
	1800	7.3	3.6
	1200	8.6	4.3
	900	12.2	6.1
3/4	3600	9.0	4.5
	1800	10.1	5.1
	1200	12.3	6.2
	900	14.6	7.3
1	3600	11.7	5.8
	1800	12.8	6.4
	1200	14.7	7.4
	900	15.9	7.9
1 1/2	3600	17.5	8.7
	1800	17.9	8.9
	1200	20.9	10.4
	900	24.4	12.2
2	3600	22.1	11.1
	1800	23.6	11.8
	1200	24.5	12.3
	900	30.0	15.0
3	3600	32.5	16.3
	1800	33.9	17.0
	1200	34.1	17.1
	900	41.8	20.9
5	3600	50.6	25.3
	1800	52.8	26.4
	1200	58.6	29.3
	900	66.5	33.2
7 1/2	3600	75.8	37.9
	1800	76.7	38.3
	1200	82.7	41.3
	900	96.7	48.4
10	3600	93.8	46.9
	1800	96.8	48.3
	1200	101.0	50.6
	900	110.0	55.1
15	3600	127.0	53.4
	1800	132.0	66.0
	1200	138.0	69.0
	900	145.0	72.6
600	167.0	83.6	

3 PHASE

HP	SPEED RPM	AMPERES 60 Hz				
		120 Volts	208 Volts	240 Volts	480 Volts	575 Volts
1/4	3600	1.7	.86	.55	.42	.34
	1800	2.0	.99	.98	.49	.39
	1200	2.4	1.3	1.2	.59	.47
	900	2.9	1.6	1.5	.72	.58
1/3	3600	2.1	1.2	1.1	.53	.42
	1800	2.3	1.2	1.1	.57	.46
	1200	2.8	1.5	1.4	.72	.57
	900	3.4	1.8	1.7	.85	.68
1/2	3600	2.9	1.6	1.5	.72	.58
	1800	3.4	1.8	1.7	.86	.69
	1200	3.9	2.1	2.0	.99	.79
	900	5.2	2.7	2.6	1.3	1.0
3/4	3600	4.2	2.3	2.1	1.1	.84
	1800	4.7	2.5	2.4	1.2	.94
	1200	5.7	2.9	2.8	1.4	1.1
	900	6.8	3.5	3.4	1.7	1.4
1	3600	5.5	2.9	2.8	1.4	1.1
	1800	6.4	3.4	3.2	1.6	1.3
	1200	7.1	3.6	3.5	1.8	1.4
	900	8.5	4.5	4.3	2.1	1.7
1 1/2	3600	9.0	4.6	4.5	2.3	1.8
	1800	8.9	4.6	4.5	2.2	1.8
	1200	10.3	5.5	5.2	2.6	2.1
	900	11.5	5.9	5.8	2.9	2.3
2	3600	11.5	6.0	5.7	2.9	2.3
	1800	11.9	6.0	6.0	3.0	2.4
	1200	13.3	7.0	6.7	3.3	2.6
	900	14.7	7.8	7.4	3.7	2.9
3	3600	16.6	8.8	8.3	4.2	3.3
	1800	16.8	8.9	8.4	4.2	3.4
	1200	19.0	10.0	9.5	4.7	3.8
	900	21.0	11.1	10.5	5.3	4.2
5	3600	26.7	14.2	13.4	6.7	5.3
	1800	27.3	14.4	13.6	6.8	5.5
	1200	29.3	15.4	14.6	7.3	5.9
	900	32.2	17.1	16.1	8.0	6.4
7 1/2	3600	40.0	21.2	20.0	10.0	8.0
	1800	40.0	21.2	20.0	10.0	8.0
	1200	42.0	22.3	21.0	10.5	8.4
	900	47.0	24.2	23.4	11.7	9.4
10	3600	51.3	27.1	25.6	12.8	10.3
	1800	52.2	27.7	26.1	13.1	10.5
	1200	54.5	28.9	27.3	13.6	10.9
	900	58.2	31.0	29.2	14.6	11.7
600	67.6	35.8	33.8	16.9	13.5	
15	3600	77.4	41.0	38.7	19.4	15.5
	1800	76.8	41.0	38.4	19.2	15.4
	1200	78.4	42.0	39.2	19.6	15.7
	900	84.2	44.6	42.1	21.1	16.8
600	96.6	51.2	48.3	24.2	19.3	
20	3600	98.0	51.9	49.0	24.5	19.6
	1800	101	51.9	49.0	24.5	19.6
	1200	103	53.0	50.0	25.0	20.0
	900	109	57.1	53.9	26.5	21.2
600	123	62.5	59.0	29.5	23.5	
25	3600	118	62.8	59.2	29.6	23.6
	1800	125	63.6	60.0	30.0	24.0
	1200	129	66.2	62.5	31.2	25.0
	900	135	69.4	65.5	33.0	26.2
600	144	77.7	73.5	36.7	29.0	

FORMULAS FOR OBTAINING FULL LOAD AMPS FOR MOTORS OF OTHER FREQUENCY AND VOLTAGES

50 Hertz motors, multiply 60 Hz value x 1.2.

480 volt, 60 Hz motors, multiply 440 volt, 60 Hertz value x 0.92.

2 phase motor full load amp rating = 0.866 x the 3 phase full load amp rating.

2 phase, 3 wire current in common wire = 1.41 x that in the other 2 lines.

TO FIND APPROXIMATE FULL LOAD AMPS OF 25 HERTZ MOTORS

1500 rpm., 25 Hz motor amps = amps of 60 Hertz 3600 rpm. motor.

750 rpm., 25 Hz motor amps = amps of 60 Hertz 1800 rpm. motor.

SERVICE HINTS – SERVICE PROBLEMS AND REMEDIES

PROBLEM & CAUSES

1. MOTOR WILL NOT START
 - A. Line starter tripped (overloads)
 - B. Switch off
 - C. Blown fuse
 - D. Combustion control in safety position
 - E. Control circuit open

 - F. Loose wiring connections
 - G. Defective motor
 - H. Low voltage
2. MOTOR STARTS BUT PILOT DOES NOT LIGHT
 - A. Gas valve not open
 - B. No ignition spark
 - C. Low or high gas pressure
 - D. Air damper open too wide
 - E. No gas to pilot valve
3. MOTOR STARTS – PILOT LIGHTS BUT SCANNER SIGNAL READING IS LOW OR FLUCTUATING
 - A. Weak pilot
 - B. Obstructed scanner pipe
 - C. Weak scanner cell
 - D. Inoperative combustion control
 - E. Scanner viewing hot refractory
 - F. Low voltage
4. OIL FIRE DOES NOT LIGHT
 - A. No pressure or low pressure on discharge

 - B. Oil solenoid valve not opening
 - C. Excessive air - too little oil (Fire Flashes)
5. GAS FIRE DOES NOT LIGHT (USE CAUTION)
 - A. Manual gas valve closed
 - B. Butterfly valve closed
 - C. Automatic gas valves not opening
 - D. Excessive primary air
6. OIL FIRE SMOKES
 - A. Improper air - fuel ratio

 - B. Insufficient combustion air
 - C. Unit being overfired
 - D. Dirty nozzle
 - E. Oil temperature too high or low
7. OIL FIRE NOISY OR PULSATES
 - A. Fire too lean
 - B. Excessive atomizing air pressure
 - C. Excessive oil temperature

 - D. High or variable draft
8. EXCESSIVE CARBON BUILD-UP
 - A. Oil temperature too low or too high
 - B. Nozzle setting incorrect
 - C. Firing tube diameter too small
 - D. High negative (overfire) draft (variable draft)
 - E. Overfiring boiler
9. GAS FIRE NOISY OR PULSATES
 - A. Fire too lean
 - B. High or variable draft
 - C. Gas balance between outer ring and center gas can
 - D. Improper breeching design

REMEDY

- A. Reset
 - B. Put in "on" position
 - C. Replace
 - D. Reset
 - E. Check limits, and operating controls for power, to terminal 3 of Combustion control
 - F. Recheck & tighten
 - G. Replace
 - H. Minimum operating voltage, 102 volts.
- A. Check combustion control & operation of gas valve coil
 - B. Check setting of electrode, operation of transformer, porcelain wiring.
 - C. Check at tapping in gas valve on down-stream side - set at 3" to 5" W.C
 - D. Average low fire setting is 1/8" to 1/4" open
 - E. Open all manual gas cocks; purge air from gas supply line.
- A. See above - Check gas pressure, air damper opening.
 - B. Clean
 - C. Replace
 - D. Replace tubes or control
 - E. Resight scanner
 - F. Increase to at least 102V
- A. Check for fuel in tank, open suction line valves, check & clean strainer check suction line for leaks - use vacuum gage, reprime pump.
 - B. Check & replace solenoid coil - check wiring connections.
 - C. Reset air damper or oil valve lever — see linkage diagrams dirt or improperly assembled nozzle - water in fuel supply.
- A. Open
 - B. Readjust - see linkage diagrams
 - C. Check for power to operator replace operator.
 - D. Reset air damper
- A. Readjust linkage - refer to diagrams & tables - use combustion testing instruments.
 - B. Provide more openings to boiler room.
 - C. Check rating of boiler & firing rate of burner.
 - D. Clean & reassemble properly.
 - E. Check oil temperature - reset controls according to chart recommendations.
- A. Readjust oil valve lever to increase rate - or reduce air supply.
 - B. Readjust by pass air valve on compressor.
 - C. Readjust control at heater - if large variation in oil temperature may require additional heating equipment.
 - D. Install draft controls.
- A. Readjust oil temperature controls.
 - B. See diagrams.
 - C. See diagram covering minimum sizes.
 - D. Use choke band.
 - E. Check boiler rating & reset burner.
- A. Increase gas pressure or open gas butterfly valve slightly.
 - B. Install or adjust draft controls.
 - C. Install trim washers, part no. 144779 in gas tubes to center can.
 - D. Redesign breeching in accordance with good industry practice.

SERVICE HINTS – SERVICE NOTES

1. A damper ring (choke ring band) may be installed on 6.3, 9.8, 15, 22.5 and 25.5 burners where a negative draft exists – the choke ring may add stability to the flame pattern and assist in keeping the diffuser clean. It fits in between the outside of the air diffuser and the burner throat.

NOTE: A reduction in the rating of the burner, of approximately 20%, can be expected if the burner is firing against a positive furnace pressure.

2. High lubricating oil consumption at the air compressor may be caused by dirty air inlet filters. A dirty filter raises the inlet suction and pulls the lubricating oil past the piston on the suction stroke.
3. Make sure that all heater elements in the motor starters are sized correctly. Check the motor nameplate for the correct amperage rating.
4. All the data in this manual has been obtained at 1500 feet elevation and 70°F air temperature. At different elevations and air temperatures the capacities will vary from the test data.
5. Refractory chambers – gas – oil units – it is recommended that the oil nozzle assembly be removed if gas is to be fired for an extended period of time. This will extend the life of the nozzle. Additionally, the burner firing head assembly should be properly protected to assure long life.

When the lead sulfide type flame scanner is used it may sense hot or glowing refractory materials and can cause shutdowns. The scanner in these instances must be resighted where it will not view the refractory material. Brackets available through service parts department.

6. Two burners in one boiler may cause a problem in the scanners picking up a signal from the other unit. The scanners may have to be resighted to give them greater separation.
7. If much higher than normal gas ring pressures are encountered, the gap between the rings should be examined to make sure it has not been filled with refractory material or that it has not been damaged by excessive heat.
8. All atomizing burners are designed to operate against a positive fire box pressure. It is therefore possible to overfire the unit, when a negative fire box pressure exists, and damage the burner motor. The amperage draw of the burner motor should not exceed the name plate rating at high fire.
9. Nozzle cleaning – On an initial start up, dirt and pipe chips are apt to collect in the nozzle and a one-sided or distorted fire will result. The nozzle may be disassembled and washed with solvent. Hard deposits should be removed with a wood stick; never with a file or hard metal probe. The center pin in a Monarch nozzle is factory set and must not be changed.
10. Air diffuser cleaning – The air diffusers should be checked about once a week. If carbon build-up appears, remove cone and clean thoroughly. It is important all deposits be removed from between the blades as well as from the face.

The frequency of cleaning will depend on the grade of oil and operating conditions. About one week to one month is average, but inspection should be made weekly until the necessary cleaning period is determined.

11. Nozzle oil spray or drip, on PAO & PAGO units, during the pre and post purge periods can be due to a dirty and/or leaking check valve or solenoid valve.
12. Off Center or One-Sided Fires

Due to the furnace design or overall application of a specific job, the burners' fire may be somewhat off center. Normally, such fires need not be corrected; if the fire is clean and otherwise satisfactory, a certain amount of one sidedness is not harmful. Some hints to correct the fire are as follows:

If an oil fire hugs one side of the furnace:

- a. Clean the nozzle
- b. Check that the nozzle assembly aims straight ahead. This may be modified by loosening the set screws where the oil and air pipes enter the body and aligning the nozzle pipes so as to be parallel with the center line of the burner.
- c. On 15 size burners, and larger, when the fire favors the top or bottom of the furnace tube, it may be corrected by adjusting the relation between the two air dampers so that one leads the other as required.

One sided gas fires may be corrected on the 15 size burner by adjustment of the internal ring as described elsewhere in this manual.

SERVICE HINTS – MAINTENANCE INSTRUCTIONS

A. GENERAL

1. After the burner has been adjusted by the installer, settings of linkage, fuel pressures and temperatures should not be changed or tampered with by persons not thoroughly experienced with the burner and fuel system.
2. Once a plant burning No. 6 fuel oil is in operation and temperatures and pressures have leveled off, it is preferable to keep it running rather than shut down over weekends or other off periods. Less difficulty and better overall economy will be obtained by holding the burner on instead of allowing the entire system to cool off. Control arrangements are available to provide a low pressure or temperature in the boiler during such periods.
3. Keep the burner, the boiler and entire boiler room clean. Do not allow fuel to leak anywhere. It is not only unsightly, but dangerous. A clean boiler room is essential to first class boiler operation.
4. Keep a constant check on the fuel supply. Do not depend entirely on "automatic delivery". Watch the supply yourself. Check fuel gauges occasionally. Lack of fuel is hard to explain and can cause untold difficulty to all concerned. Even when the supply is replenished, repriming and venting may require considerable time which will further delay the restoration of heat.
5. Never close up vents supplying air to the boiler room, no matter how cold the boiler room gets. If this causes undue hardship, ducts can be installed to bring the outside air close to the burner inlet so the entire boiler room is not cooled by outside air. In any case, the burner must get an ample supply of air.

6. If bottled gas is employed for ignition, keep track of the supply and reorder, before the tanks are empty.

B. CLEANING ELECTRIC OIL HEATERS

Once each year, or oftener if required, remove the electric heater element from the shell. Clean sludge from the bottom of the shell and the heater elements. Flush if necessary.

C. AIR COMPRESSOR — REFER TO CHART IN THE COMPRESSOR SECTION

Note — Use oil developed for air compressor use only.

D. AIR DIFFUSER — REFER TO SERVICE NOTES SECTION

E. NOZZLES — REFER TO SERVICE NOTES SECTION. BE VERY CAREFUL AS A VERY SMALL NICK WILL DESTROY THE SPRAY PATTERN.

F. STRAINERS

Check the strainer once a month until the required cleaning period is determined. A vacuum gage between the pump and the strainer will show an increasing vacuum if cleaning is needed. When cleaning the strainer be sure the cap gasket is in good condition and the mating surfaces are clean. A light coat of grease helps secure a tight joint. Do not forget to close the gate valve ahead of the strainer before removing the cap so as to not lose the oil prime.

G. LIMIT CONTROLS

The operation of the limit controls should be checked at least once a week. In addition the low water cutoffs should be blown down once a week to remove rust, dirt, etc. and to check their operation for shutting off the burner.

H. COMBUSTION CONTROLS

The operation of the combustion control should be checked in accordance with recommendation of the manufacturer. Information covering the control furnished with each burner is put in the pocket on the control panel door.

I. ANNUAL

Have the burner inspected and checked by trained service personnel for efficient safe operation.

QUINCY AIR COMPRESSOR

LOCATION:

Select a location for the air compressor that is as close as possible to the point where the compressor air is to be used. In selecting this

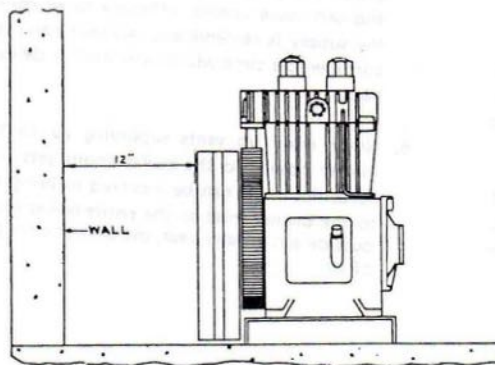

FIGURE NO. 35

location, it is of utmost importance that the compressor have an ample supply of cool, dry and well circulated air. The pulley side of the compressor should be placed toward the wall (see Fig. 35) for safety reasons, but in no case should the pulley be closer than twelve inches from the wall to allow ample circulation of air from the fan type pulley to the cylinder.

The foundation should be solid and substantial enough to absorb mechanical vibration. Generally, concrete foundations are the most satisfactory; foundation bolts should be imbedded in the concrete.

LUBRICATION:

Fill the compressor crankcase with the recommended grade and viscosity of oil furnished. Check the electric motor or engine manufacturer's recommendation and make certain that they are properly lubricated at all times.

Do not fill above the full mark on the bayonet oil gauge. Oil level must be maintained between the two marks on the gauge. **Never allow it to fall below the lower mark.**

ELECTRICAL:

Have all electrical connections made by a competent electrician. It is imperative that the electric motor have the same characteristics as the electric line to which it is to be connected. Full voltage must be supplied to the motor as it is indicated on the motor name plate.

AIR INTAKE:

A clean, dry air supply is essential to the satisfactory operation of your Quincy air compressor. The standard air filter that the compressor is equipped with when leaving the factory is of sufficient size and design to meet normal conditions, if properly serviced in accordance with the maintenance section of this manual. If, however, the compressor is to be installed in a location where considerable dust, dirt and other contaminants are prevalent, it is strongly recommended that an oil bath filter be substituted for the standard filter. If long runs of intake pipe are necessary to supply the compressor with cool air, the intake pipe should be increased by one pipe size for each eight feet of additional length beyond the intake port of the compressor head. If the intake is piped to the outside, a hood should be installed over the filter, to prevent the entrance of rain and snow into the intake of the compressor head.

LUBRICATION

CHANGE OIL

If the oil becomes dirty or contaminated before 500 operating hours, or 90 days have elapsed, it should be changed. The crankcase should be thoroughly cleaned every time the oil is changed. Do not use kerosene or similar agents for flushing the crankcase.

OIL TYPE

Care of Air Compressor. It is very important proper lubricating oil be used and crankcase be kept filled at all times.

The Quincy compressor requires "Sohiovis No. 65" or equal high quality compressor oil. See Quincy Instructions. 1 Gallon Part No. 143047.

OIL PRESSURE ADJUSTMENT

The oil pressure is regulated by a spring loaded ball mounted in bearing carrier or in the crankcase on some models. Spring pressure is controlled by an adjusting screw. Turning the screw inwardly increases the pressure, whereas turning the screw outwardly will decrease the pressure. Be sure to loosen the adjustment lock nut before making any controlled adjustment, and turn adjustment screw slowly until the oil gauge registers approximately 15 lbs. After adjustment has been made, tighten the adjustment screw lock nut.

AIR COMPRESSOR MAINTENANCE CHART

CHECK	DAILY	WEEKLY	MONTHLY	YEARLY
1. CHECK OIL PRESSURE — MAINTAIN AT 15 POUNDS	X			
2. CHECK OIL LEVEL - MAINTAIN BETWEEN HIGH AND LOW LEVEL MARKS ON BAYONET OIL GAUGE. CAUTION: DO NOT OVERFILL	X			
3. GIVE COMPRESSOR OVERALL VISUAL CHECK	X			
4. CHECK AIR DISTRIBUTION SYSTEM FOR AIR LEAKS		X		
5. CLEAN COOLING SURFACES OF COMPRESSOR INTERCOOLER AND AFTERCOOLER		X		
6. OPERATE SAFETY VALVES			X	
7. REPLACE OR CLEAN INTAKE FILTER ELEMENT			**	
8. INSPECT OIL FOR CONTAMINATION AND CHANGE IF NECESSARY			X	
9. CHECK BELTS FOR CORRECT TENSION. PROPER TENSION OF THE BELTS SHOULD BE GAUGED BY FLEXING THE BELT WITH THE HAND A DISTANCE EQUAL TO THE OVERALL THICKNESS OF THE BELT.			X	
10. CHECK PULLEY CLAMP BOLTS AND SET SCREWS FOR TIGHTNESS			X	
11. INSPECT VALVE ASSEMBLIES				***
12. INSPECT CUSHION CHAMBER AND DISCHARGE LINE FOR EXCESSIVE CARBON ACCUMULATION				X
13. INSPECT PRESSURE SWITCH DIAPHRAGM AND CONTACT POINTS				X
14. INSPECT CONTACT POINTS IN MOTOR STARTER				X
15. LUBRICATE ELECTRIC MOTOR OR ENGINE IN ACCORDANCE WITH MANUFACTURERS RECOMMENDATIONS				X
** CHECK MORE OFTEN IF EXTREMELY DIRTY CONDITIONS EXIST				
*** EVERY 6 MONTHS				

ADJUSTING ELECTRIC OIL HEATERS — WELLS HEATER

To adjust thermostatic switch, remove the cover exposing the thermostatic switch nut. When the oil is cold the contacts of this switch are closed, permitting a flow of current to the heater. When the oil reaches the temperature for which the thermostat is set the circuit is broken. To raise the temperature of the oil, turn the adjusting

nut counter clockwise. If too high, turn it clockwise. The temperature of the oil flowing thru the heater may be checked by reading the thermometer.

Total temperature range of the CAAQ model Wells heater is 100°–200°F.

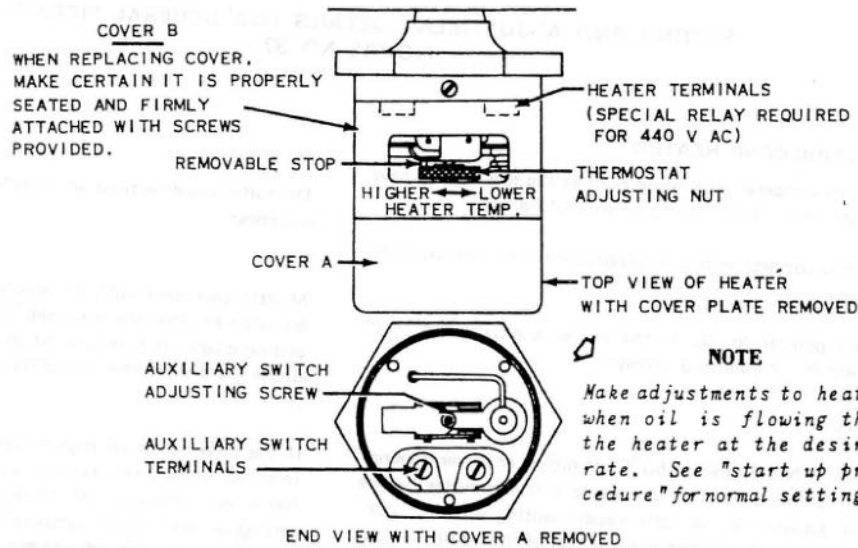

SETTING AND ADJUSTMENT DETAILS FOR WELLS ELECTRIC OIL PREHEATERS
FIGURE NO. 36

GENERAL FITTINGS CO. HEATER

Each unit has the work "Top" inscribed on the flange. The purpose of this is to insure the location of the thermostat in the correct position for optimum differential within the preheating shelf.

THE MOUNTING HOLE NEAREST TO THE WORD "TOP" SHOULD BE INSTALLED IN THE SHELL SO THAT ITS POSITION WOULD MOST NEARLY COINCIDE WITH A 12 O'CLOCK POSITION. In other words, the "TOP" hole should be installed at top center.

All units (Except 2 KW) are equipped with "modulation control" when designed for single phase operation. This control is factory preset for 150°F as is the non-modulation control provided on the 2 KW models. TO ADJUST THE TEMPERATURE TO HIGHER SETTINGS. ROTATE TEMPERATURE SETTING SCREW COUNTER CLOCKWISE.

The secondary or "cold oil lockout" control located on the left side of the mounting bracket — see Figure 37 is factory preset.

It may be adjusted upwards or downwards by rotating the br headed temperature setting screw in the same manner as the ma. control.

The "Secondary" or cold oil lockout control is entirely independent of the "primary" or operating control. The cold oil lock-out may be adjusted as to temperature without in any way affecting the main control setting.

ALL UNITS MUST BE CONNECTED TO SUPPLY SERVICE CORRESPONDING WITH THE NAMEPLATE AND INTERNAL DIAGRAM SPECIFICATIONS.

Three phase models are not equipped with "Modulation Control". They are equipped with a single switch main control which actuates a suitable contactor.

All models are designed for connection to Alternating Current service. DO NOT USE ON DIRECT CURRENT.

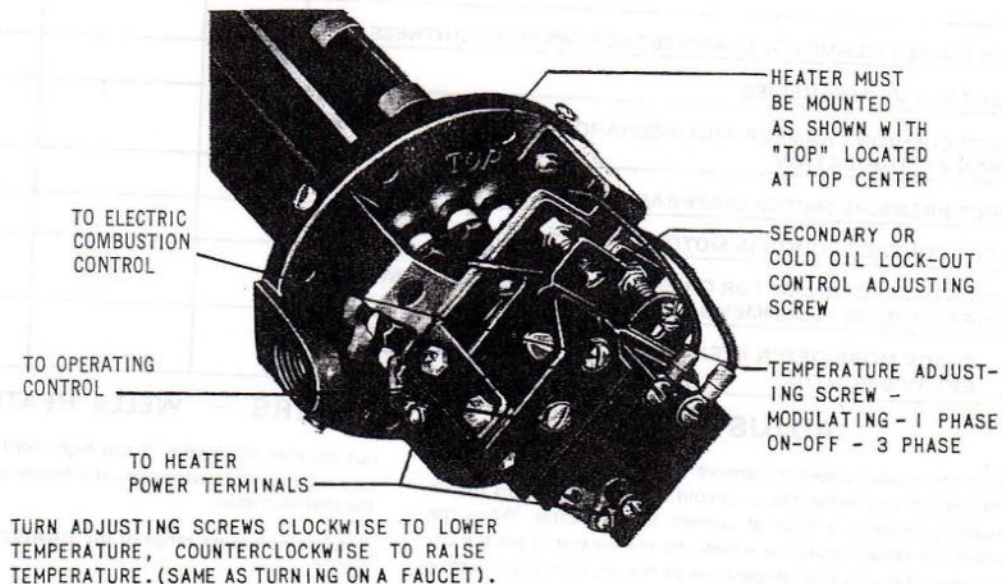

SETTING AND ADJUSTMENT DETAILS FOR GENERAL FITTING CO.
FIGURE NO. 37

WARREN ELECTRIC CORP. HEATER

Install heater with temperature sensing bulb at the top — use a new gasket. (Also note small "TOP" stamp on edge of flange).

Remove cover and connect wiring in accordance with labeled direction inside cover.

Turn thermostat pointer to No. 1 (the heater is now in the "off" position — except in extreme cold climate).

Fill casing with oil.

Now set pointer to No. 6 (about 150°F) or higher or lower depending on desired temperature. Let unit cycle a few minutes before making further adjustments. A little experimenting with the control will do no harm and will give you the feel of the control — just wait a few cycles each time an adjustment is made so as to allow the heater thermostat to seek its new setting.

The following directions are only for models with interlock auxiliary switches:

Models equipped with an auxiliary interlock switch are factory adjusted to close the interlock switch. If a higher or lower interlock setting is desired, just turn the small brass knurled knob DIRECTLY under the dial pointer in accordance with the directions on the name plate.

If the interlock is set higher than the oil temperature the au. interlock switch will prevent your burner from operating and th heater will also stay off. If this cocurs either lower the interlock setting or raise the oil temperature. This feature is in the design to minimize incorrect adjustment and function of your heater and interlock control.

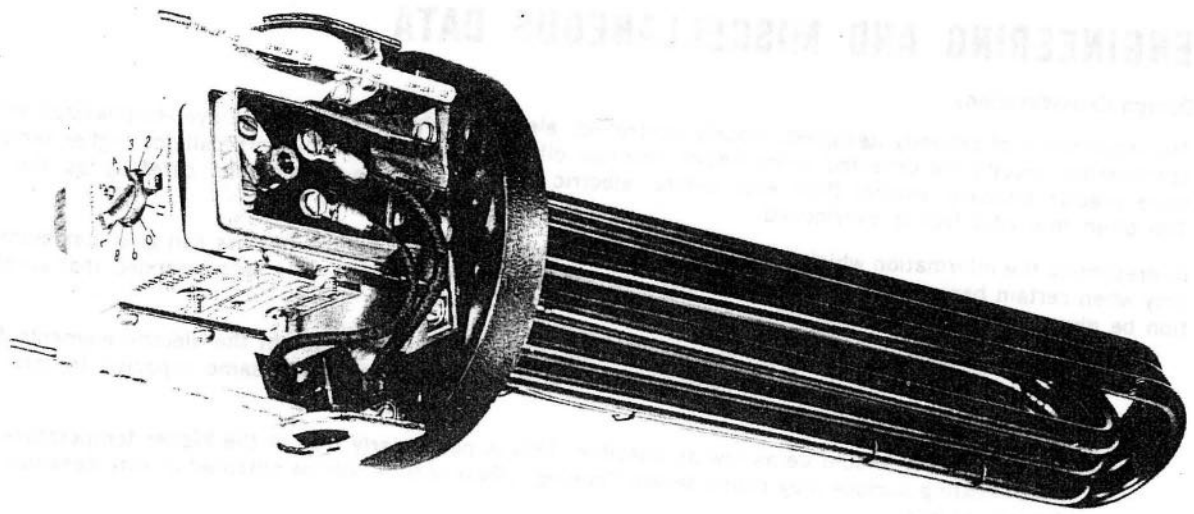

WARREN ELECTRIC OIL PREHEATER
FIGURE NO. 38

Thermostat Operation

Temperature sensing bulb (not shown) expands on a temperature rise and pushes center drive shaft (2) up. Operating levers (3) and (4) are actuated by movement of the center drive shaft which transmits motion to the levers through precision balls (5), (6), (7), and (8). Lever movement is precise and consistent due to free rolling ball bearing action. The ball bearings (5), (6),

(7), and (8) are held in place by springs (9) and (10) and positioned by retainers (11) and (12). The oil temperature setting is adjusted by rotating the center drive shaft (2) with the pointer (14) which is attached to the spline end of the center drive shaft. The interlock temperature is adjusted by rotating the knurled brass handle (15).

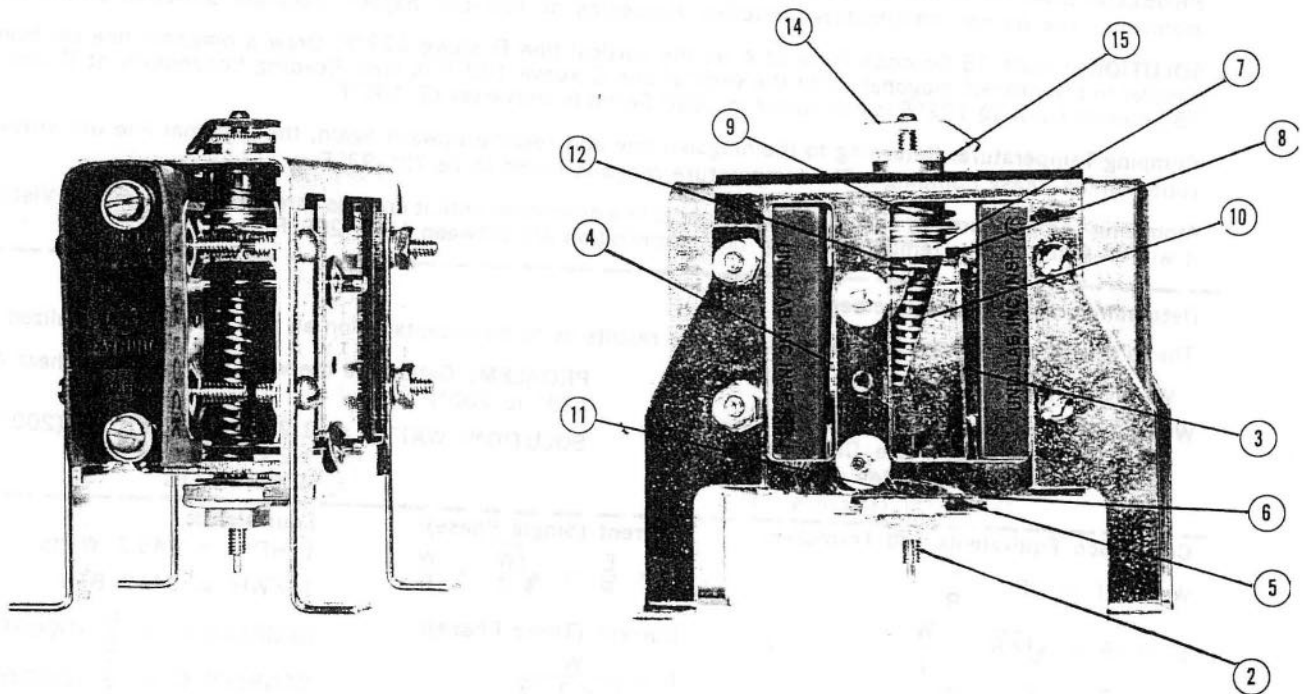

THERMOSTAT OPERATION—WARREN ELECTRIC OIL PREHEATER
FIGURE NO. 39



ENGINEERING AND MISCELLANEOUS DATA

Design Considerations

The importance of properly designed, closely controlled, electric preheaters cannot be over-emphasized where optimum combustion results are expected using heavy, residual oils. Because today's burners call for higher temperatures and more precise viscosity control than ever before, electric heaters must be selected as carefully as the burner itself. Too often this vital fact is overlooked.

In presenting the information which follows, it should be understood that electric heaters can give maximum performance only when certain basic precepts are recognized. Therefore, prior to selection, it is recommended that careful consideration be given to the following points:

1. The heater should be designed so that oil is in contact with the surface of the electric elements for as long as possible. In this regard, a long heater is preferable to a short one of the same capacity. Integral baffles, when available, are also desirable.
2. The watt density should be as low as possible. This is particularly true at the higher temperature ranges where lack of heating surface may cause severe "coking". Best results will be obtained if watt densities are limited to 12 w.s.i. or less.
3. The ability to maintain close temperature control is partially dependent upon pressure. Even with a low watt density heater, high temperatures, without sufficient pressure, will cause vaporizing of the lighter hydrocarbons, and will result in excessive gas formation within the heater manifold. Close temperature control is impossible, and faulty atomization occurs. In order to avoid this difficulty, pressures of at least 35 psi should be maintained for temperatures of 180° F, and at least 70 psi for temperatures of 200° F and higher.
4. Care should be taken in choosing the correct heater rating. If the output is low, the unit will stay on longer than it should, may cause "coking", and will not heat the oil to the desired temperature. Under certain circumstances it may also lead to severe chattering of the contactor on three phase or high voltage applications. If the output of the heater is too high, temperature "over-riding" and poor control may result.

Determining Pumping & Atomizing Temperatures

The Viscosity-Temperature Chart on the opposite page can be extremely useful in determining the approximate temperatures to which any fuel oil must be heated for best pumping and atomizing results. Two facts must be known: (1) the viscosity of the unheated oil, and (2) the viscosity desired at the burner nozzle. Generally speaking, viscosities of bulk oil are expressed in Saybolt Seconds **Furol @ 122° F**, while atomizing viscosities are given in Saybolt Seconds **Universal @ 100° F**. The following example will serve to illustrate how the chart is used.

PROBLEM: Given an oil with a viscosity of 75 Seconds Furol @ 122° F, find the temperature range for best pumping and atomizing. The burner manufacturer requires viscosities of 100-150 Saybolt Seconds **Universal** at the burner nozzle.

SOLUTION: Locate 75 Seconds Furol at A on the vertical line B above 122° F. Draw a diagonal line up from this point, parallel to the nearest diagonal, until the vertical line C above 100° F is met. Reading horizontally at D you will see that 75 Seconds Furol @ 122° F is equivalent to 1530 Seconds Universal @ 100° F.

Pumping Temperature: Returning to the diagonal line and reading upward again, the diagonal line will cross through the zone marked "Easy Pumping". The temperature range is found to be 72°-93° F.

Atomizing Temperature: By extending the diagonal line downward until it crosses through the "Atomizing Viscosity Range", it will be seen that the temperatures for best atomization are between 184°-209° F.

Determining Wattage Requirements

The following formula gives sufficiently accurate results as to be acceptable on all but the most specialized applications:

$$\text{WATTS} = 1.25 \times \text{GPH} \times \Delta T$$

Where: GPH = Gallons Per Hour
 ΔT = Temperature Difference between Inlet and Outlet Oil (Degrees F.)

PROBLEM: Determine the wattage required to heat 40 GPH from 120° to 200° F.

$$\begin{aligned} \text{SOLUTION: WATTS} &= 1.25 \times 40 \text{ GPH} \times (200^\circ - 120^\circ) \\ &= 1.25 \times 40 \times 80 \\ &= \mathbf{4000 \text{ WATTS}} \end{aligned}$$

Conversion Equivalents and Formulas:

$$W = EI = I^2R = \frac{E^2}{R}$$

$$E = IR = \sqrt{WR} = \frac{W}{I}$$

$$R = \frac{E}{I} = \frac{E^2}{W} = \frac{W}{I^2}$$

Current (Single Phase):

$$I = \frac{E}{R} = \sqrt{\frac{W}{R}} = \frac{W}{E}$$

Current (Three Phase):

$$I = \frac{W}{E \times 1.73}$$

Equivalents:

$$1 \text{ HP} = 745.2 \text{ Watts}$$

$$1 \text{ KWH} = 3412 \text{ BTU}$$

$$\text{DEGREES F} = \frac{9}{5} (\text{DEGREES C}) +$$

$$\text{DEGREES C} = \frac{5}{9} (\text{DEGREES F} - 32)$$

Where: W = Power in Watts; I = Current in Amperes; E = Potential in Volts; R = Resistance in Ohms



LECTRICOIL

AUTOMATIC FUEL OIL PREHEATER

VISCOSITY-TEMPERATURE CHART

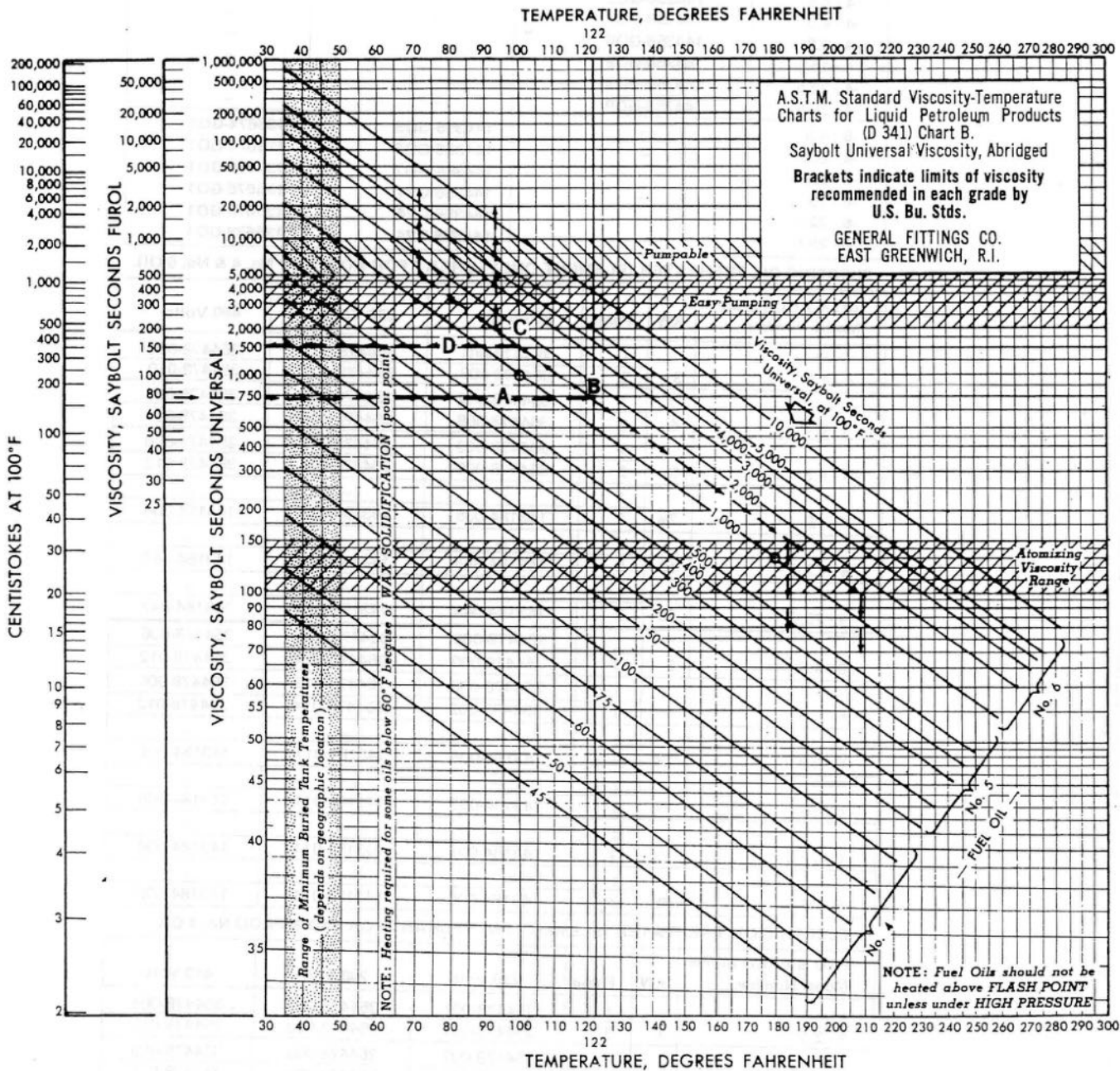

FIGURE 40

STANDARD AIR COMPRESSOR/PUMP ASSEMBLIES FOR AO & AGO BURNERS

AO & AGO Burner Model Number	Compressor/Pump Assm. (No electric oil heater; the heater is mounted on burner for No. 4 oil units)	Compressor/Heater Assm. (No. oil pump; the pump is mounted on a separate base)	Oil pump assembly (For No. 6 oil firing)
-2 - 4.5	144356-GO2	—	—
-2 - 6.3	144356-GO2	—	—
-2 - 9.8	144356-GO6	—	—
-2 - 15	144356-GO9	—	—
-2 - 22.5	144356-GO9	—	—
-2 - 25.5	144356-GO9	—	—
-4 - 4.5	144356-GO2	—	—
-4 - 6.3	144356-GO2	—	—
-4 - 9.8	144356-GO6	—	—
-4 - 15	144356-GO9	—	—
-4 - 22.5	144356-GO9	—	—
-4 - 25.5	144356-GO9	—	—
-6 - 4.5	—	144356-GO3	135674-GO1
-6 - 6.3	—	144356-GO3	135674-GO1
-6 - 9.8	—	144356-GO7	135676-GO1
-6 - 15	—	144356-G24	135676-GO1
-6 - 22.5	—	144356-G24	135678-GO1
-6 - 25.5	—	144356-G24	135678-GO1

ELECTRIC OIL PREHEATER (ELEMENT ONLY) CHART FOR AO & AGO No. 4 & No. 6 OIL

AO & AGO Burner Model Number	KW	Phase	230 Volts	208 Volts	460 Volts
- 4 - 4.5	3	1	354478-001	354478-002	354478-004
		3	354478-007	354478-008	354478-010
- 4 - 6.3	4	1	354478-002	354478-003	354478-005
		3	354478-008	354478-009	354478-011
- 4 - 9.8	5	1	354478-003	354478-013	354478-006
		3	354478-009	354478-014	354478-012
- 4 - 15	7½	1	—	—	—
		3	143184-005	143184-011	143184-006
- 4 - 22.5	10	1	—	—	—
		3	143184-045	143184-046	143184-047
- 4 - 25.5	10	1	—	—	—
		3	143184-045	143184-046	143184-047
- 6 - 4.5	5	1	354478-003	354478-013	354478-006
		3	354478-009	354478-014	354478-012
- 6 - 6.3	5	1	354478-003	354478-013	354478-006
		3	354478-009	354478-014	354478-012
- 6 - 9.8	7½	1	—	—	—
		3	143184-005	143184-011	143184-006
- 6 - 15	7½	1	—	—	—
		3	143184-005	143184-011	143184-006
- 6 - 22.5	7½	1	—	—	—
		3	143184-005	143184-011	143184-006
- 6 - 25.5	7½	1	—	—	—
		3	143184-005	143184-011	143184-006

ELECTRIC OIL PREHEATER (ELEMENT ONLY) CHART FOR PAO & PAGO No. 4 OIL

PAO & PAGO Burner Model Number	KW	Phase	230 Volts	208 Volts	440 Volts
4 - 2.1	3	1	354478-001	354478-002	354478-004
		3	354478-007	354478-008	354478-010
4 - 4.5	4	1	354478-002	354478-003	354478-005
		3	354478-008	354478-009	354478-011
4 - 6.3	5	1	354478-003	354478-013	354478-006
		3	354478-009	354478-014	354478-012
4 - 9.8	5	1	354478-003	354478-013	354478-006
		3	354478-009	354478-014	354478-012
4 - 15	7½	1	—	—	—
		3	143184-005	143184-011	143184-006

REF. NO.	PART NUMBER	DESCRIPTION	BURNER MODEL		4.5		9.8		15		
			4.5	6.3	6.3	6.3	9.8	9.8	15	15	
			6.3	6.3	28.4	6	28.4	6	28.4	6	
			OIL		28.4		6		28.4		
			ASSEMBLY PART NO. 144356-								
			G02	G03	G06	G07	G09	G24			
1	354290-003	Compressor-Quincy 216	1	1							
2	354290-005	Compressor-Quincy 230			1	1	1	1			
3	354169-003	Pump-Viking FH432	1		1		1				
4	MM-1834-301	Motor - 2HP - 230/460V - 60 Cy. - 3 PH	1	1							
5	MM-1924-301	Motor - 3HP - 230/460V - 60 Cy. - 3 PH				1	1				
6	MM-2014-301	Motor - 5HP - 230/460V - 60 Cy. - 3 PH							1	1	
7	354051-002	Pulley - Pump - 8" O.D. - 1/2" Bore	1		1						
8	354051-005	Pulley - Pump - 4-1/2" O.D. - 1/2" Bore						1			
9	144358	Pulley - Motor - 6" O.D. - 7/8" Bore	1	1							
10	143178	Pulley - Motor - 6" O.D. - 1-1/8" Bore				1	1				
11	354467-001	Pulley - Motor - 9" O.D. - 1-1/8" Bore							1	1	
12	144365	Pulley - Motor 4-1/2" O.D. - 7/8" Bore	1								
13	144360	Pulley - Motor - 4-1/2" O.D. - 1-1/8" Bore				1			1		
14	354055-001	Key - Special	1								
15	330157	Belt - Pump - No. 4L370	1								
16	84602	Belt - Pump - No. 4L390				1					
17	330736	Belt - Pump - No. 4L320								1	
18	354287-001	Belt Set - Compressor - No. B71	1	1							
19	354287-002	Belt Set - Compressor - No. B75				1	1				
20	354287-004	Belt Set - Compressor - No. B78								1	1
21	354373-001	Flexible Hose - 3/4"	1	1							
22	354373-002	Flexible Hose - 1"				1	1	1	1	1	
23	144906-G05	Tube Assembly - Bypass	1	1							
24	144906-G06	Tube Assembly - Bypass				1	1	1	1	1	
25	115399-G01	Relief Valve - 0 - 50 Lbs.	1		1						
26	115399-G02	Relief Valve - 50 - 100 Lbs.								1	
27	116106	Pressure Gauge - 0 - 100 Lbs.	2	1	2	1	2	1			
28	Refer to Chart	PreHeater - Oil			1		1		1		
29	83642	Gasket - Preheater			1		1			1	
30	143310-G01	Shell Assembly - Preheater			1		1			1	
31	143729	Air Filter - Dry Type	1	1	1	1	1	1	1	1	
32	140232	Needle Valve - 1/4" N.P.T. x 3/8" Tube	1	1	1	1	1	1	1	1	
33	354466-001	Pressure Switch - Air	1	1	1	1	1	1	1	1	
34	144364-G01	Air Chamber Assembly	1	1	1	1	1	1	1	1	
35	144257	Belt Guard Assembly	1	1	1	1	1	1	1	1	
	143047	Oil - Compressor - 1 Gal. (Not Shown)	1	1	1	1	1	1	1	1	
	144353	Air Filter - Oil Bath Type (Optional)	0	0	0	0	0	0	0	0	
	144406	Pressure Switch - Low Compressor Oil (Optional)	0	0	0	0	0	0	0	0	
	MM-1834-302	Motor - 2HP - 208V - 60 Cy. - 3 PH (Optional)	0	0							
	MM-1924-302	Motor - 3HP - 208V - 60 Cy. - 3 PH (Optional)				0	0				
	MM-2014-302	Motor - 5HP - 208V - 60 Cy. - 3 PH (Optional)								0	0
1	354457-002	Compressor - Curtis C50	1	1							
2	354457-001	Compressor - Curtis C80				1	1	1	1	1	

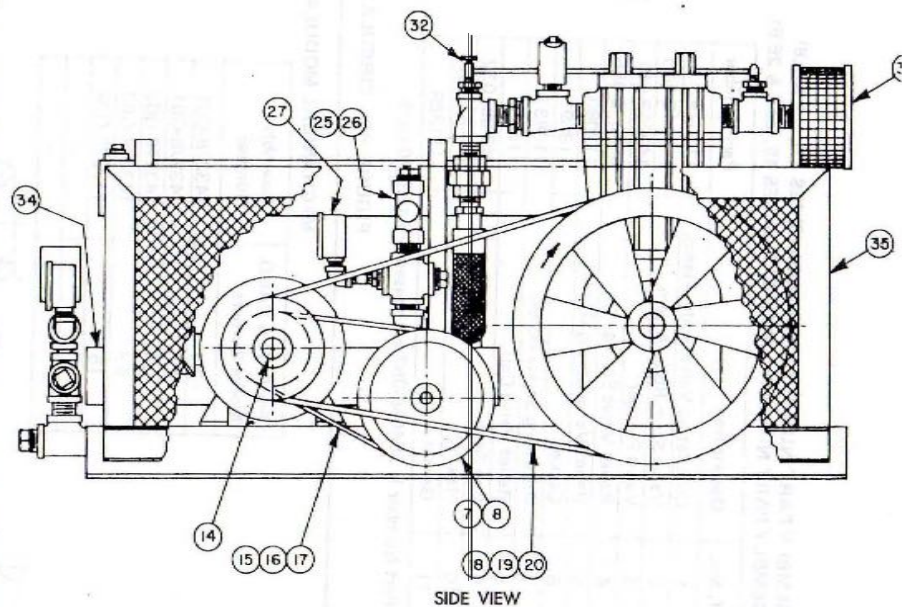
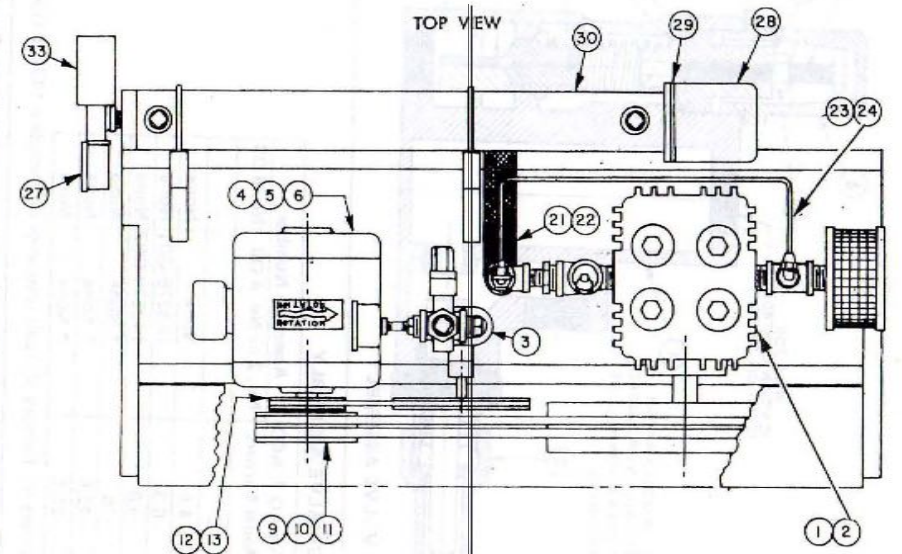

AIR COMPRESSOR/PUMP
ASSEMBLY (QUINCY)

FIGURE 41

ASSEMBLY PART NUMBER 118220-G05 (SIZES 4.5, 6.3 & 9.8)
ASSEMBLY PART NUMBER 118220-G03 (SIZES 15, 22.5 & 25.5)

Ref. No.	Description	Part Number
1	Circulating Valve Body Assem.	117079
2	Valve Stem Body Assem.	149412-G01
3	Valve Plunger	149259-001
4 *	Relief Valve Spring *	354088-056*
5	Relief Valve Spring Guide	117080
6	Gasket	118595
7	Adjusting Screw Holder	110837
8	Relief Valve Cap	110836
9	Cap Screw	H3-05-032
10	Hex Nut	MS-51968-1
11	Gasket	111369

* Part Number is 354088-053 with assembly 118220-G05

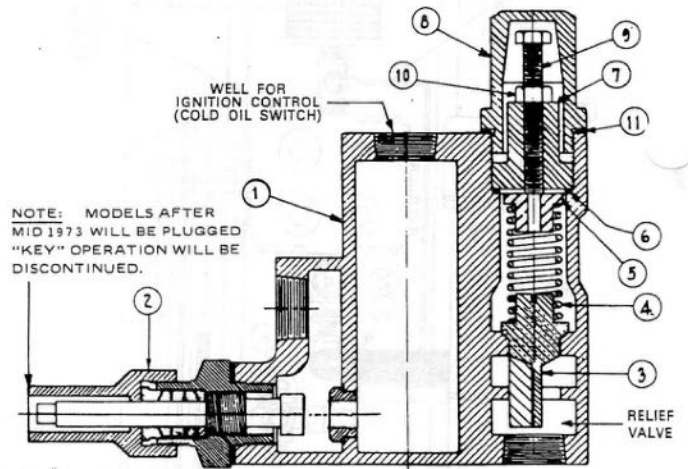

FIGURE 42 CIRCULATING VALVE ASSEMBLY

MECHANICAL MODULATING VALVE ASSEMBLY

For PAO & PAGO Model Burners	Assembly Number
- 2.1	143278-G01
- 4.5	143278-G01
- 6.3	143278-G03
- 9.8	143278-G03
- 15	143278-G04
-	-
-	-

For AO & AGO Model Burners	Assembly Number	
	No. 2 or No. 4 Oil	No. 6 Oil
-	-	-
- 4.5	None	None
- 6.3	143278-G01	None
- 9.8	143278-G02	None
- 15	* None	None
- 22.5	* None	None
- 25.5	* None	None

* Burners for Factory Mutuals Insurance do include a 143278-G04

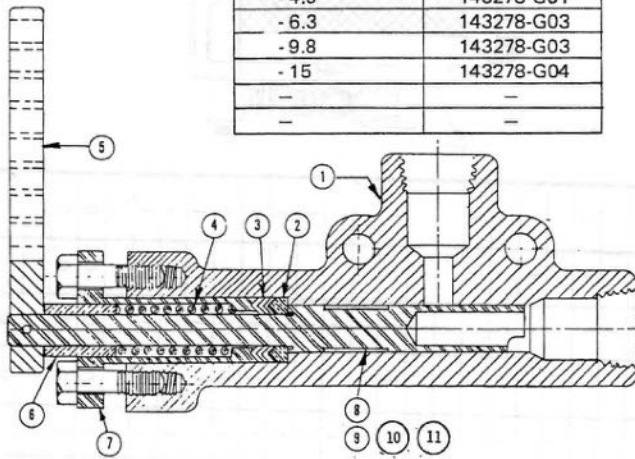

Ref No.	Part Number	Description	Assembly Part No. 143278-			
			GO1	GO2	GO3	
1	143281	Mod. Valve Body	1	1	1	1
2	123405	Male Packing Ring	1	1	1	1
3	123406	V-Ring Hyd. Packing	1	1	1	1
4	354088-050	Spring	1	1	1	1
5	142909	Lever	1	1	1	1
6	123623	Bushing	1	1	1	1
7	123624	Packing Gland	1	1	1	1
8	118718	Hi-Low Reg. Valve (1/16" Stamped No. 1)	1			
9	117084	Hi-Low Reg. Valve (1/8" Stamped NO. 2)		1		
10	140213	Hi-Low Reg. Valve (1/4" Stamped No. 4)				1
11	117094	Hi-Low Reg. Valve (3/16" Stamped No. 3)				1

FIGURE 43 MECHANICAL MODULATING OIL VALVE ASSEMBLY

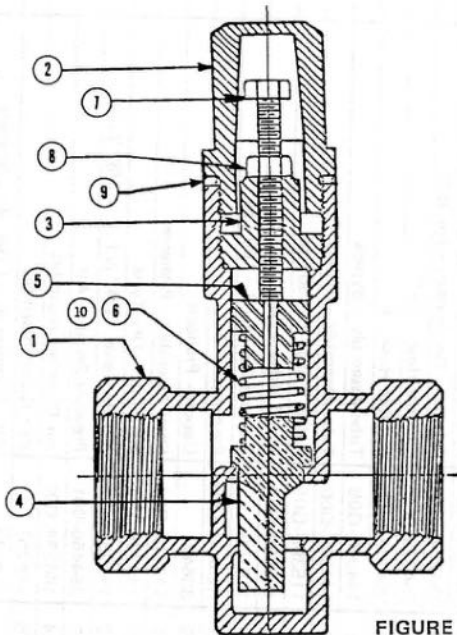
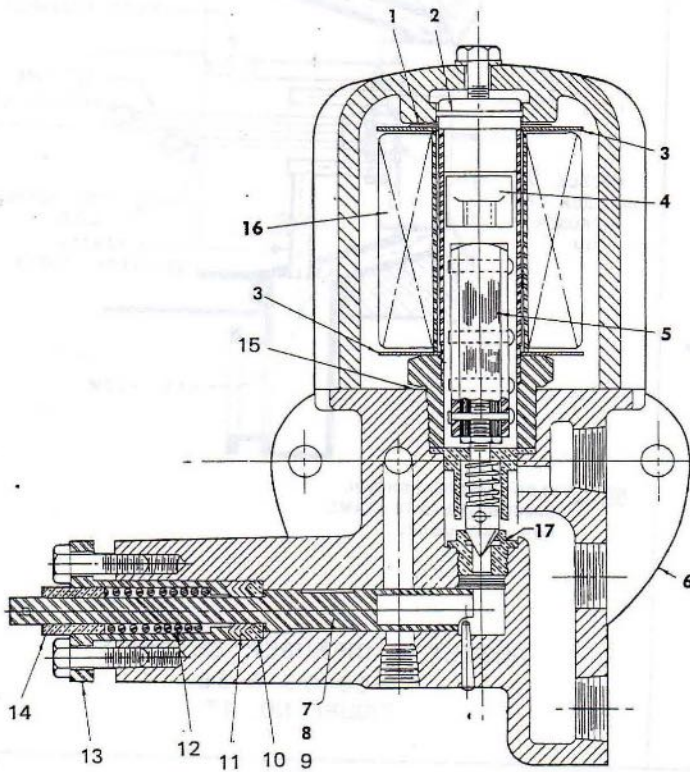

FIGURE 44 RELIEF VALVE ASSEMBLY

Ref. No.	Description	Assembly Part Number	
		115399-	GO1 GO2
1	Valve Body	115398	1 1
2	Relief Valve Cap	110836	1 1
3	Adjusting Screw Holder	110837	1 1
4	Relief Valve Plunger	115218	1 1
5	Spring Guide	115217	1 1
6	Relief Valve Spring	354088-053	1
7	Cap Screw	H 3-05-032	1 1
8	Nut	MS 51968-1	1 1
9	Gasket	111369	1 1
10	Relief Valve Spring	354546-001	1



ELECTRIC HI-LOW VALVE ASSEMBLY

Ref. No.	Part Number	Description	Assembly Part Number 144466-		
			G01	G09	G13
1	H6-03-018	Coil Clamping Washer	1	1	1
2	117862	Stub Core Ring	1	1	1
3	H6-02-002	Coil Insulation Washer	1	1	1
4	122197	Stub Core Tube Assy.	1	1	1
5	117171	Needle Valve Assy.	1	1	1
6	121438	Hi-Low Oil Valve Body Assy.	1	1	1
7	117084	Hi-Lo Reg. Valve - 1/8" Orifice - No. 2 Stamp	1		
8	117094	Hi-Lo Reg. Valve - 3/16" Orifice - No. 3 Stamp		1	
9	140213	Hi-Lo Reg. Valve - 1/4" Orifice - No. 4 Stamp			1
10	123405	Male Packing Ring	1	1	1
11	123406	V-Ring - Hydraulic Packing (Set)	1	1	1
12	115336	Spring	1	1	1
13	123624	Packing Gland	1	1	1
14	123623	Bushing	1	1	1
15	118995	Bonnet Gasket	1	1	1
16	354028-002	Coil Assy. - 110V., 50/60V.	1	1	1
17	124823	Valve Stem Seat	1	1	1

FIGURE 45 ELECTRIC HI-LOW (MAGNETIC MODULATING) VALVE ASSEMBLY

For AO & AGO Model Burners	Assembly Number		
	No. 2 Oil	No. 4 Oil	No. 6 Oil
4.5	144466-G01	144466-G01	144466-G09
6.3	None	None	144466-G09
9.8	None	None	144466-G09
15	*144466-G09	*144466-G09	144466-G13
22.5	*144466-G13	*144466-G13	144466-G13
25.5	*144466-G13	*144466-G13	144466-G13

* Not included with burners for Factory Mutuals Insurance

OIL SOLENOID VALVES (NOT ILLUSTRATED)

For PAO & PAGO Model Burners	Part Number
- 2.1	354057-059
- 4.5	354057-059
- 6.3	354057-059
- 9.8	354057-058
- 15	354057-058
-	-
-	-

For AO & AGO Model Numbers	Part Number	
	No. 2 or No. 4 Oil	No. 6 Oil
-	-	-
- 4.5	None	None
- 6.3	354057-048	None
- 9.8	354057-048	None
- 15	* None	* None
- 22.5	* None	* None
- 25.5	* None	* None

* For Factory Mutuals Insurance a 354472-001 valve is included.

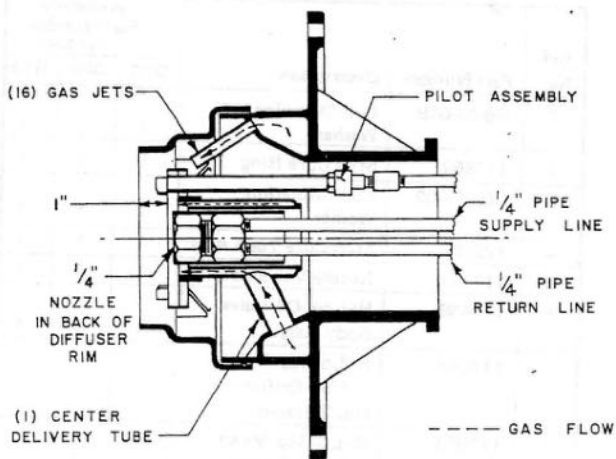

NOTE: PAGO MODEL SHOWN.
DIMENSIONS ARE SAME
FOR PAO MODEL.

NOZZLE & DIFFUSER SETTINGS
PAGO-2.1 & 4.5
FIGURE NO. 46

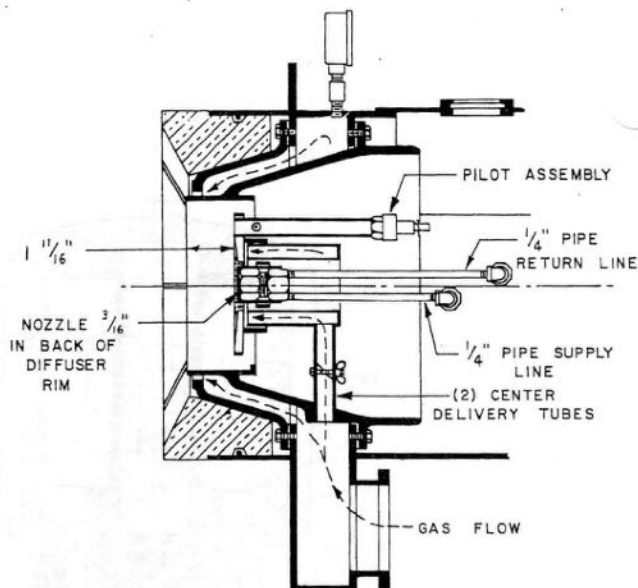

NOTE: PAGO MODEL SHOWN.
DIMENSIONS ARE SAME
FOR PAO MODEL.

NOZZLE & DIFFUSER SETTINGS
PAGO-6.3 & 9.8
FIGURE NO. 47

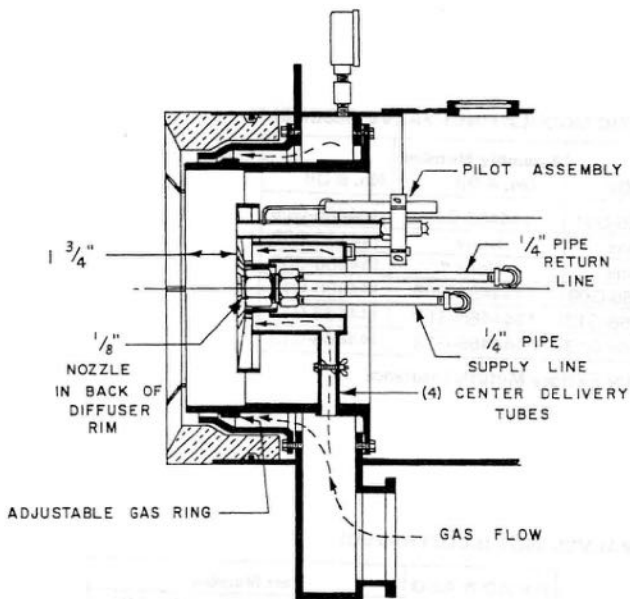

NOTE: PAGO MODEL SHOWN.
DIMENSIONS ARE SAME
FOR PAO MODEL.

NOZZLE & DIFFUSER SETTINGS
PAGO-15
FIGURE NO. 48

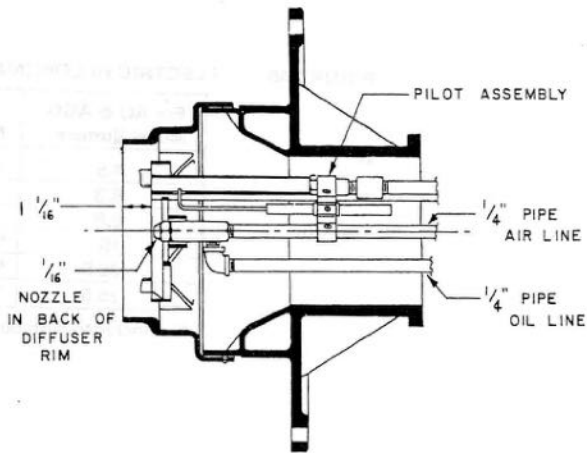

NOZZLE & DIFFUSER SETTINGS
AO-4.5
FIGURE NO. 49

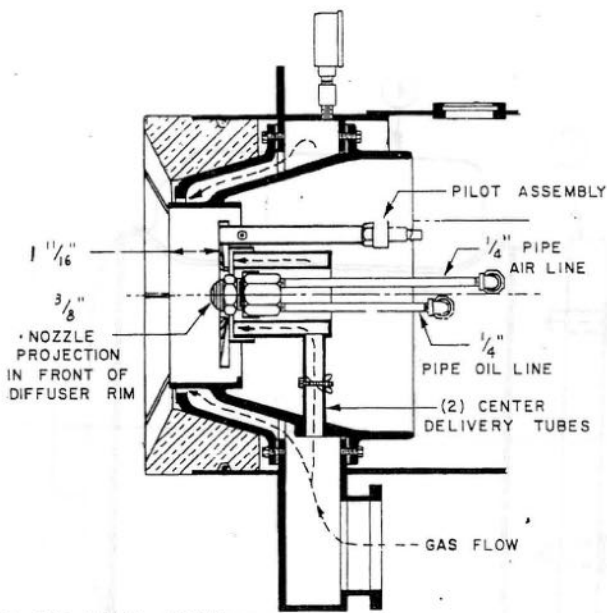

NOTE: AGO MODEL SHOWN.
DIMENSIONS ARE SAME
FOR AO AND AG MODELS.

NOZZLE & DIFFUSER SETTINGS
AGO-6.3 & 9.8
FIGURE NO. 50

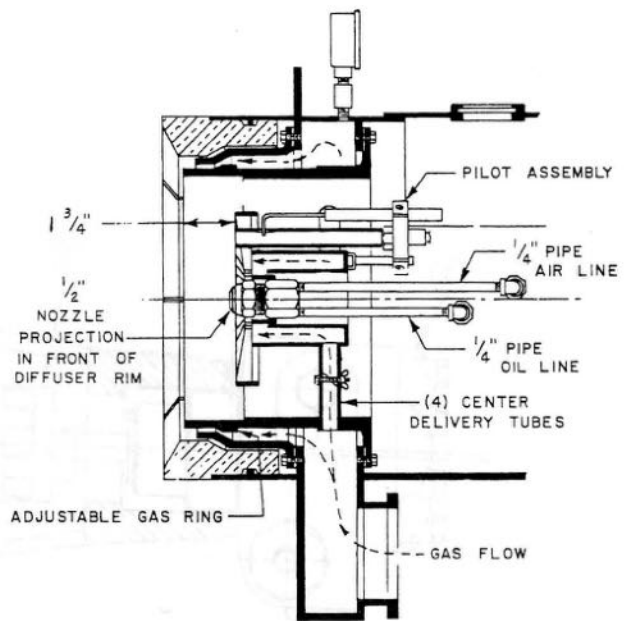

NOTE: AGO MODEL SHOWN.
DIMENSIONS ARE SAME
FOR AO AND AG MODELS.

NOZZLE & DIFFUSER SETTINGS
AGO-15
FIGURE NO. 51

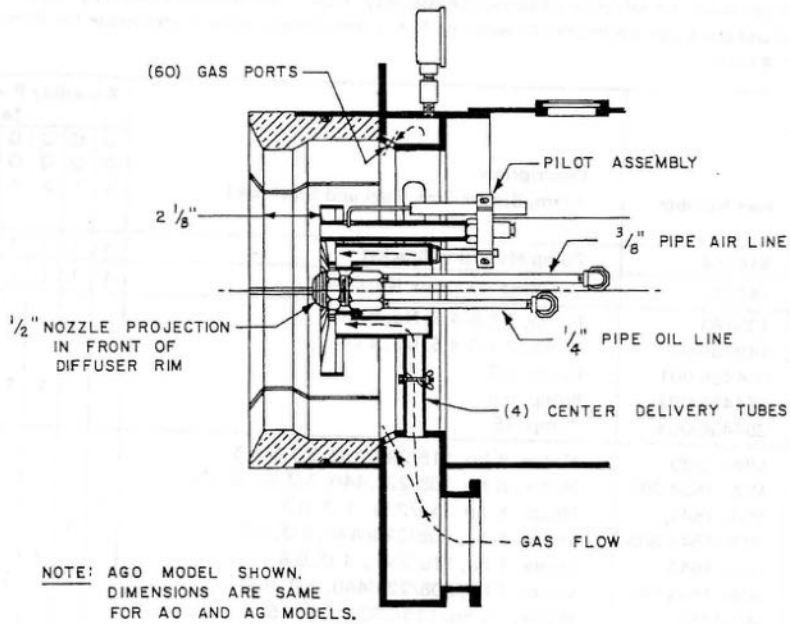

NOTE: AGO MODEL SHOWN.
DIMENSIONS ARE SAME
FOR AO AND AG MODELS.

NOZZLE & DIFFUSER SETTINGS
AGO-22.5 & 25.5
FIGURE NO. 52

NO. SK-D-11134

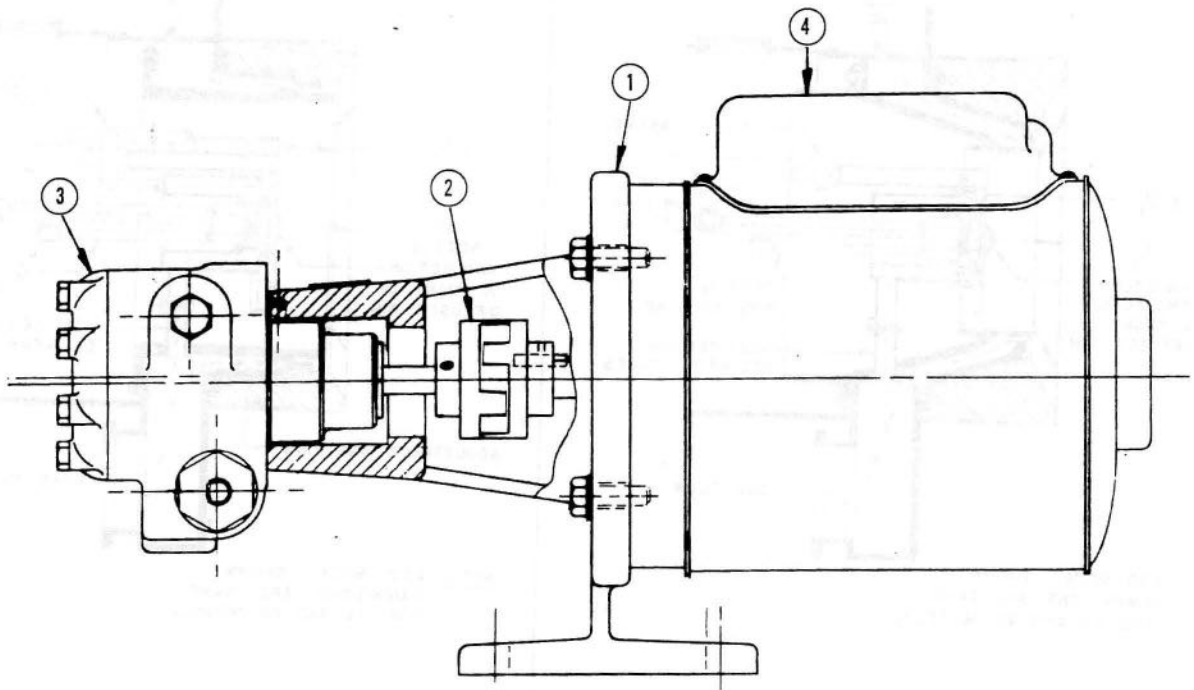

FIGURE 53
REMOTE PUMP ASSEMBLIES FOR PAO – PAGO BURNERS

(To use chart, for selection of complete assembly, from the description column, first select burner size, fuel and electrical requirements; when no fuel is mentioned, pump is applicable for all fuels – No. 2 and No. 4 Oil).

Ref. No.	Part Number	Description (Item, Burner Size, Fuel and Electrical)	Assembly Part Number 143677-											
			G O 3	G O 4	G O 5	G O 6	G O 7	G O 8	G O 9	G O 0	G O 1	G O 2		
1	144264	Pump Mounting Bracket	1	1	1	1	1	1	1	1	1	1	1	1
2	143541	Coupling – Climax No. C – 3	1	1	1	1	1	1	1	1	1	1	1	1
3	133163	Pump, 2.1 & 4.5, No. 2 Oil									1	1		
	149496-G01	Pump, 2.1 & 4.5, No. 4 Oil											1	1
	354456-001	Pump, 6.3	1	1										
	354456-002	Pump, 9.8			1	1								
	354456-003	Pump, 15					1	1						
4	MM-1539	Motor, ¾ hp, 115/230 1 Ø, 2.1 & 4.5									1		1	
	MM-1538-305	Motor, ¾ hp, 208/220/440, 3 Ø, 2.1 & 4.5										1		1
	MM-1541	Motor, ¾ hp, 115/230, 1 Ø, 6.3	1											
	MM-1542-305	Motor, ¾ hp, 208/220/440, 3 Ø, 6.3		1										
	MM-1643	Motor, 1 hp, 115/230, 1 Ø, 9.8			1									
	MM-1644-305	Motor, 1 hp, 208/220/440, 3 Ø, 9.8				1								
	MM-1750	Motor, 1½ hp, 115/230, 1 Ø, 15					1							
	MM-1751-305	Motor, 1½ hp, 208/220/440, 3 Ø, 15						1						

* These remote pump assemblies are optional, Standard 2.1 & 4.5 size burners include the oil pump integral with the burner.

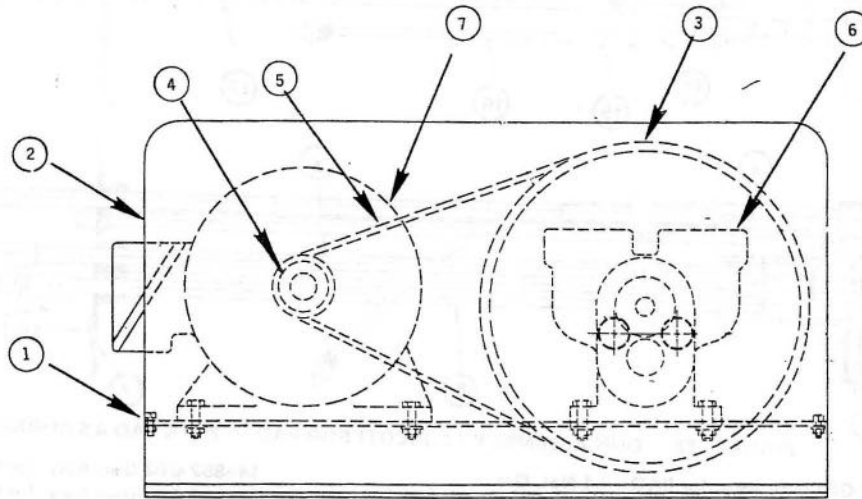

FIGURE 54

REMOTE OIL PUMPS FOR NO. 6 OIL FIRING AO & AGO BURNERS

(To use chart, for selection of complete assembly, from the description column, first select pump model and electrical requirements)

Ref. No.	Part Number	Description	Assembly Part Number											
			135674-				135676-				135678-			
			G1	G2	G3	G4	G1	G2	G3	G4	G1	G2	G3	G4
1	135668	Base	1	1	1	1	1	1	1	1	1	1	1	1
2	135673	Belt Guard Assembly	1	1	1	1	1	1	1	1	1	1	1	1
3	135691	Pump Pulley	1	1	1	1	1	1	1	1	1	1	1	1
4	135687	Motor Pulley, 5/8" Bore	1	1	1	1	1	1	1	1				
	135688	Motor Pulley, 7/8" Bore									1	1	1	1
5	354349-012	Belt	1	1	1	1	1	1	1	1	1	1	1	1
6	125157	Pump Assembly - H - 100 (3/4" I.P.S.)	1	1	1	1								
	125171	Pump Assembly - H - 200 (1" I.P.S.)					1	1	1	1				
	125177	Pump Assembly - H - 300 (1 1/2" I.P.S.)									1	1	1	1
7	MM-1318-301	Motor, 1/3 hp, 230/460, 3Ø, H-100	1											
	MM-1318-302	Motor, 1/3 hp, 208, 3Ø, H-100		1										
	MM-1318-305	Motor, 1/3 hp, 208/220/440, 3Ø, H-100			1									
	MM-1319	Motor, 1/3 hp, 115/230, 1Ø, H-100				1								
	MM-1416-301	Motor, 1/2 hp, 230/460, 3Ø, H-200					1							
	MM-1416-302	Motor, 1/2 hp, 208, 3Ø, H-200						1						
	MM-1416-305	Motor, 1/2 hp, 208/220/440, 3Ø, H-200							1					
	MM-1419	Motor, 1/2 hp, 115/230, 1Ø, H-200								1				
	MM-1516-301	Motor, 3/4 hp, 230/460, 3Ø, H-300									1			
	MM-1516-302	Motor, 3/4 hp, 208, 3Ø, H-300										1		
	MM-1516-305	Motor, 3/4 hp, 208/220/440, 3Ø, H-300											1	
	MM-1519	Motor, 3/4 hp, 115/230, 1Ø, H-300												1

Note: 4.5 & 6.3 Burner Sizes use H-100 pump; 9.8 & 15 sizes use H-200; 22.5 & 25.5 sizes use H-300 model pump set.

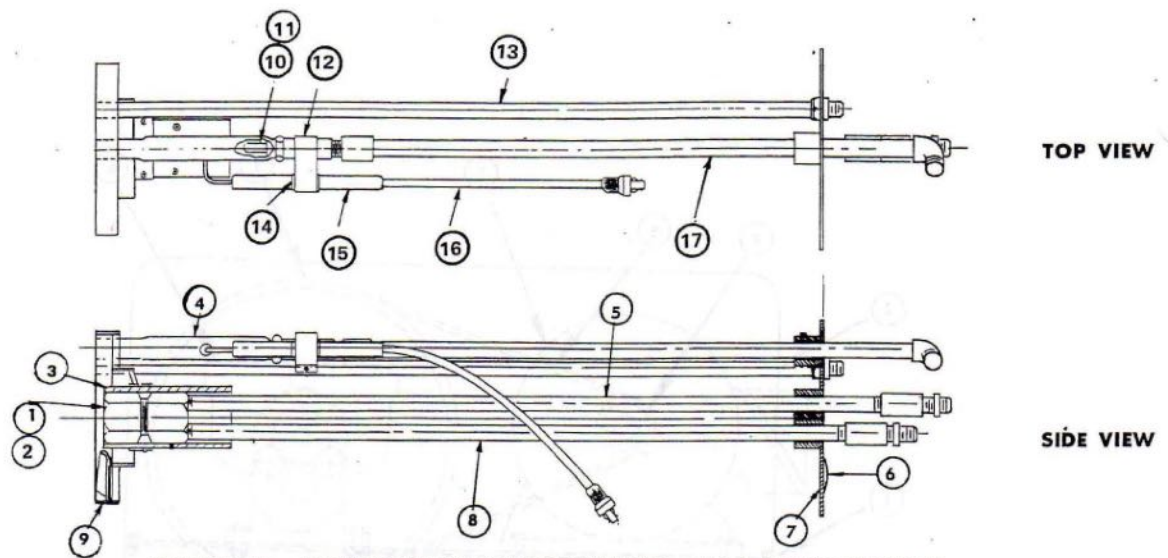

FIGURE 55 GUN ASSEMBLY (& PILOT) FOR PAO - 2.1 & PAO 4.5 BURNERS

144852-G01 Gun Assy. for PAO - 2.1 Nat. Gas
144852-G02 Gun Assy. for PAO - 2.1 L.P. Gas

144852-G03 Gun Assy. for PAO - 4.5 Nat. Gas
144852-G04 Gun Assy. for PAO - 4.5 L.P. Gas

Ref. No.	Part Number	Description	Assembly Part No. 144852-			
			G O 1	G O 2	G O 3	G O 4
1	145446-001	Nozzle, Return Flow	1	1		
2	145446-003	Nozzle, Return Flow Sleeve, Return Flow			1	1
3	144823-001	Nozzle	1	1	1	1
4	149278-G01	Pilot Tube	1	1	1	1
5	354030-028	Nipple 1/4" x 23" Lg.	1	1	1	1
6	354274-004	Glass	1	1	1	1
7	144905-G01	Frame Cover Assy.	1	1	1	1
8	354030-027	Nipple 1/4" x 22" Lg.	1	1	1	1
9	144851-G01	Diffuser Assy.	1	1	1	1

Ref. No.	Part Number	Description	Assembly Part No. 144852-			
			G O 1	G O 2	G O 3	G O 4
10	149274-001	Orifice (Nat. Gas)	1		1	
11	149275-001	Orifice (L.P. Gas)		1		1
12	144826-001	Electrode Support	1	1	1	1
13	149051-001	Thin Wall Conduit 1/2" x 24"	1	1		
14	82944	Split Bushing	1	1	1	
15	149281-G01	Electrode Assy.	1	1	1	1
16	132799	Ignition Cable Assy.	1	1	1	1
17	354030-024	Nipple 1/4" x 19" Lg.	1	1	1	1

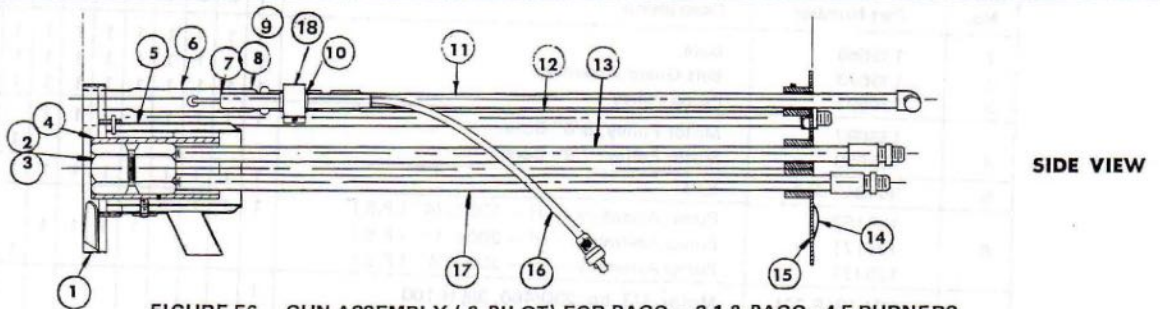

FIGURE 56 GUN ASSEMBLY (& PILOT) FOR PAGO - 2.1 & PAGO - 4.5 BURNERS

144828-G01 Gun Assy. for PAGO - 2.1 Nat. Gas
144828-G02 Gun Assy. for PAGO - 2.1 L.P. Gas

144828-G03 Gun Assy. for PAGO - 4.5 Nat. Gas
144828-G04 Gun Assy. for PAGO - 4.5 L.P. Gas

Ref. No.	Part Number	Description	Assembly Part No. 144828-				No.	Part Number	Description	Assembly Part No. 144828-			
			G O 1	G O 2	G O 3	G O 4				G O 1	G O 2	G O 3	G O 4
1	144805-G01	Diffuser Assy.	1	1	1	1	10	82944	Split Bushing	1	1	1	1
2	145446-001	Return Flow Nozzle	1	1			11	354030-024	Nipple - 1/4" x 19" Lg.	1	1	1	1
3	145446-003	Return Flow Nozzle			1	1	12	354143-001	Conduit - 1/2" x 24" Lg. Scanner	1	1	1	1
4	144838-G01	Sleeve Assy.	1	1	1	1							
5	144817-G01	Sleeve Assy.	1	1	1	1	13	354030-028	Nipple - 1/4" x 23" Lg.	1	1	1	
6	149278-G01	Pilot Tube	1	1	1	1	14	354274-004	Observation Port Glass	1	1	1	
7	149281-G01	Electrode Assy.	1	1	1	1	15	144905-G01	Frame Cover Assy.	1	1	1	1
8	149274-001	Orifice (Nat. Gas)	1		1		16	132799	Ignition Cable Assy.	1	1	1	1
9	149275-001	Orifice (L.P. Gas)		1		1	17	354030-027	Nipple - 1/4" x 22" Lg.	1	1	1	1
							18	144826-001	Support Electrode	1	1	1	1

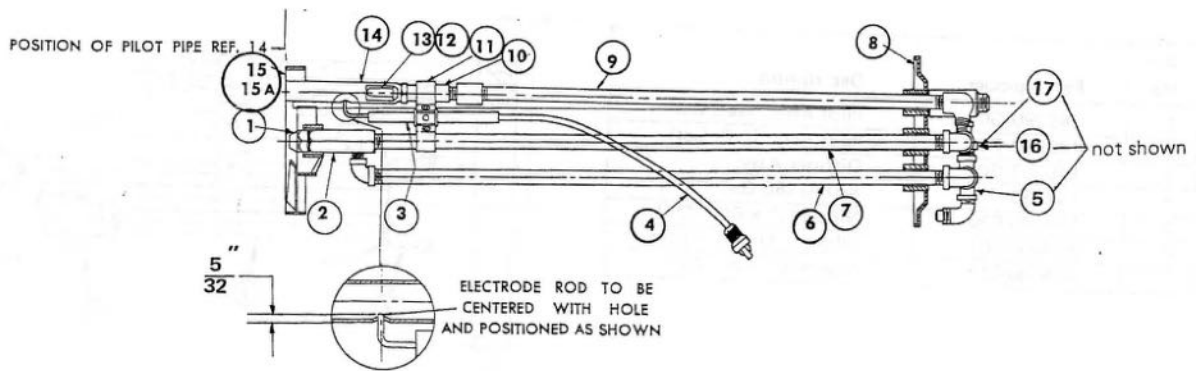
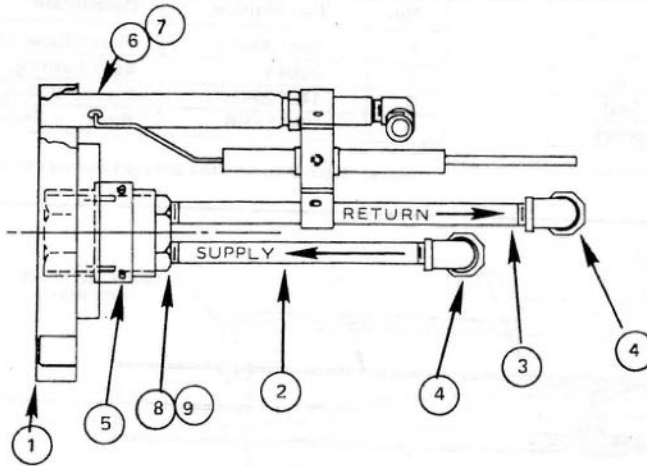

FIGURE 57 GUN ASSEMBLY (& PILOT) FOR AO - 4.5 BURNERS

149285-G01 Gun Assy for No. 2 & No. 6 Oil (Nat. Gas Pilot)
 149285 - G02 Gun Assy for No. 2 & No. 6 Oil (L.P. Gas Pilot)

149285-G03 Gun Assembly for No. 4 Oil (Nat. Gas Pilot)
 149285-G04 Gun Assembly for No. 4 Oil (L.P. Gas Pilot)

Ref. No.	Part Number	Description	Assembly Part No. 149285-				Ref. No.	Part Number	Description	Assembly Part No. 149285-			
			G O 1	G O 2	G O 3	G O 4				G O 1	G O 2	G O 3	G O 4
1	354377-001	Nozzle	1	1	1	1	9	354030-023	Gas Line Nipple 1/4" x 18"	1	1	1	1
2	143876	Nozzle Adapter	1	1	1	1	10	149279-001	Pilot Adapter	1	1	1	1
3	149281-G01	Electrode Assy.	1	1	1	1	11	143905-001	Electrode Support	1	1	1	1
4	120082	Ignition Cable Assy.	1	1	1	1	12	149274-001	Orifice (Nat. Gas)	1	1	1	1
5	354274-004	Glass	1	1	1	1	13	149275-001	Orifice (L.P. Gas)		1		1
6	354030-028	Oil Line Nipple - 1/4" x 23"	1	1	1	1	14	149278-G01	Pilot Tube Assy.	1	1	1	1
7	354030-028	Air Line Nipple 1/4" x 23"	1	1	1	1	15	143889-G01	Flame Cone Assy. (Std.)	1	1	1	1
8	143882-G01	Frame Cover Assy.	1	1	1	1	15A	149258-G01	Flame Cone Assy. (Opt. (18 gph or less)	0	0	0	0
							16	354030-032	Nipple 1/4" x 6 1/2"	1	1		
							17	354030-003	Nipple 1/4" x 2"			1	1



GAS ORIFICE DRILL SIZES

149274-001	NATURAL GAS - (1) # 8 & (6) # 48
149275-001	L. P. GAS (1) # 31 & (6) # 66

FIGURE 58 GUN ASSEMBLY (& PILOT) FOR PAO - 6.3 & 9.8 BURNERS

149299-G01 PAO - 6.3 (Nat. Gas)
 149299-G02 PAO - 6.3 (L.P. Gas)

149299-G03 PAO - 9.8 (Nat. Gas)
 149299-G04 PAO - 9.8 (L.P. Gas)

Ref. No.	Part Number	Description	Assembly Part No. 149299-			
			G01	G02	G03	G04
1	149287-G01	Diffuser Assy	1	1	1	1
2	354030-032	Pipe Nipple 1/4" x 6 1/2"	1	1	1	1
3	354030-037	Pipe Nipple 1/4" x 8 3/4"	1	1	1	1
4	354060-001	Union Elbow Female	2	2	2	2
5	144959-001	Nozzle Sleeve	1	1	1	1
6	149290-G01	Pilot Assy. (Nat. Gas)	1		1	
7	149290-G02	Pilot Assy. (L.P. Gas)		1		1
8	145446-005	Return Flow Nozzle	1	1		
9	145446-007	Return Flow Nozzle			1	1

Ref. No.	Part Number	Description
1	149290-G01	Pilot Assy. (Nat. Gas)
2	149290-G02	Pilot Assy. (L.P. Gas)
3	149287-G01	Diffuser Assy.
4	142785	Nozzle (80 Gal. 100°)
5	354030-030	Nipple 1/4" x 6 1/2" (Oil)
6	354060-001	Elbow - Union - Female
7	354030-014	Nipple 1/4" x 9" (Air)

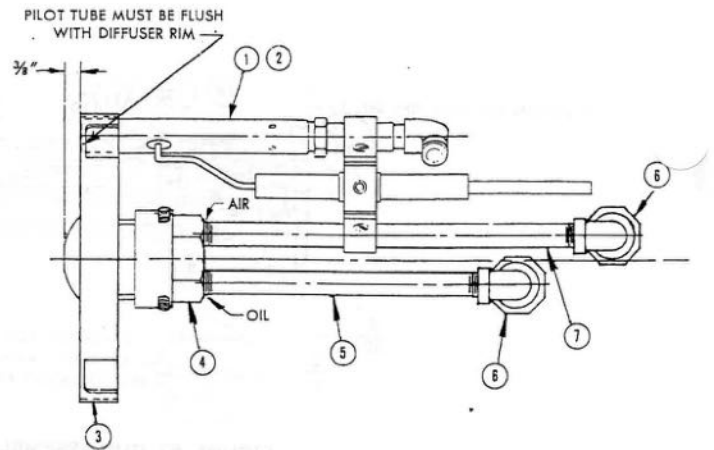

FIGURE 59 149289-G01 GUN ASSEMBLY (& PILOT) (FOR L.P. GAS, SPECIFY 149289-G02) FOR BURNERS AO - 6.3 and AO - 9.8.

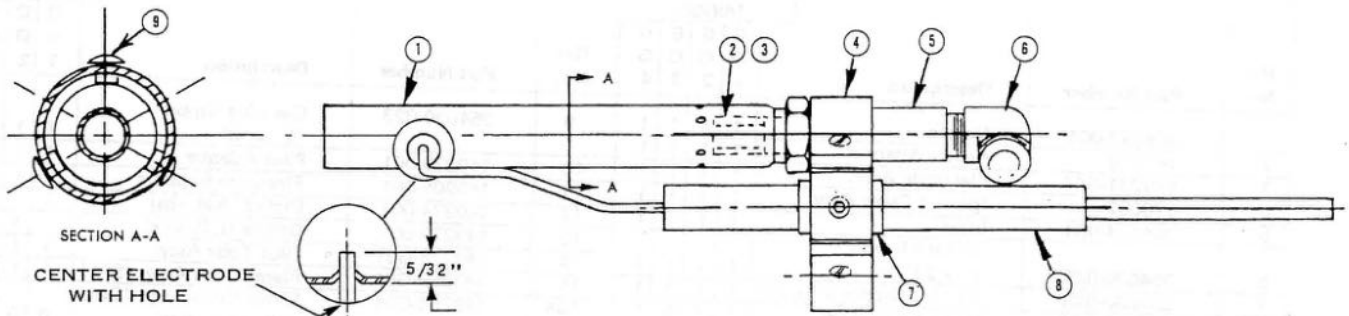

FIGURE 60 149290-G01 NATURAL GAS PILOT ASSEMBLY (FOR L.P. GAS, SPECIFY 149290-G02) FOR BURNERS AO- 6.3 & 9.8; and PAO - 6.3 & 9.8.

Ref. No.	Part Number	Description
1	149278-G01	Pilot Tube Assy.
2	149274-001	Orifice (Nat. Gas)
3	149275-001	Orifice (L.P. Gas)
4	144220	Electrode Support
5	149279-001	Adapter

Ref. No.	Part Number	Description
6	354130-011	Flare Elbow 3/8" Tube x 1/4" N.P.T.
7	82944	Split Bushing
8	149439-G01	Electrode Assy.
9	H9-01-006	Rivet - Semi-Tubular

Note: Item 9 to be used only on burners using air restrictors

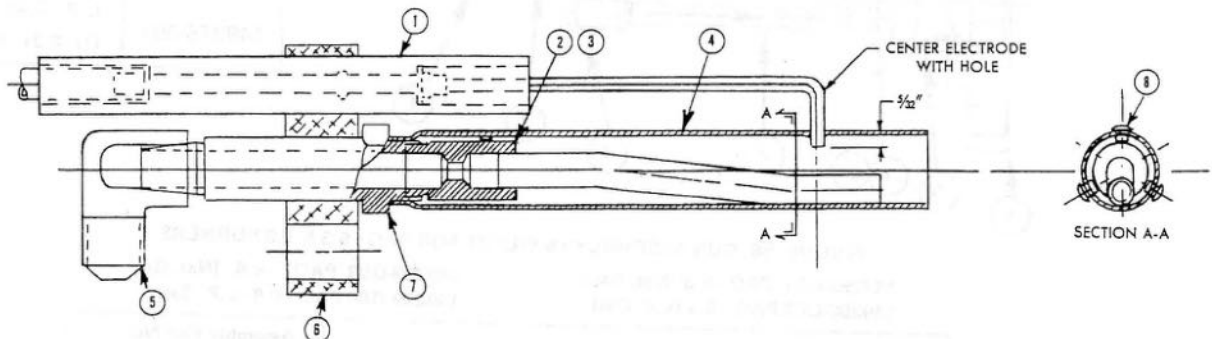

FIGURE 61 149282-G01 NATURAL GAS PILOT ASSEMBLY (FOR L.P. GAS, SPECIFY 149282-G02) FOR BURNERS AO - 15, 22.5 & 25.5; and AGO - 6.3, 9.8, 15, 22.5 & 25.5; and PAO - 15; and PAGO - 6.3, 9.8 & 15; and AG - 6.3, 9.8, 15, 22.5 and 25.5

Ref. No.	Part Number	Description
1	149280-001	Electrode Assy.
2	149274-001	Orifice (Nat. Gas)
3	149275-001	Orifice (L.P. Gas)
4	149278-G01	Pilot Tube Assy.

Ref. No.	Part Number	Description
5	354130-011	90° Elbow - 3/8" Tube to 1/4" - 18 F.f.
6	142628	Electrode Support
7	149279-001	Adapter
8	H9-01-006	Rivet

Note: Item 8 to be used only to plug Pilot Tube holes on burners using air restrictors

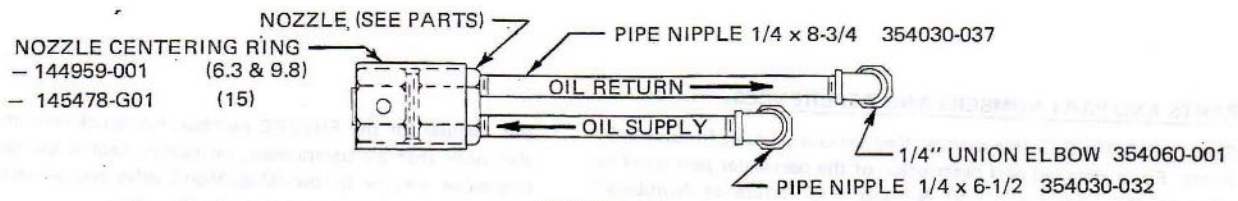

FIGURE 62
NOZZLE & PIPE ASSEMBLY

FOR PAGO - 6.3 & 9.8 & PAO - PAGO - 15
 (NOTE: SEE GUN ASSY. FOR PAO - 6.3 & 9.8 AND)
 PAO - PAGO - 2.1 & 4.5 COMPONENT PARTS

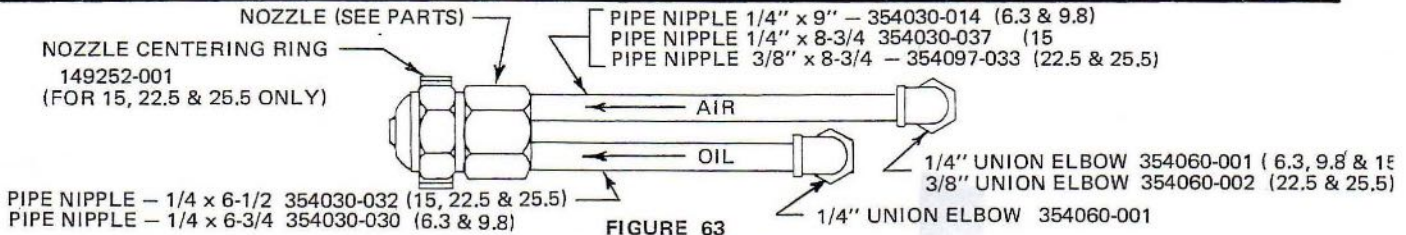
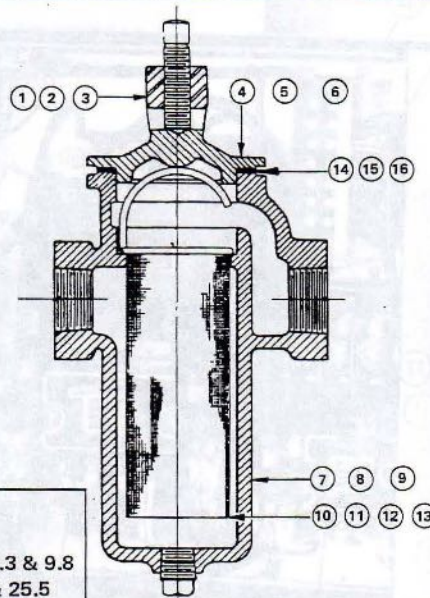

FIGURE 63

NOZZLE & PIPE ASSEMBLY

FOR AGO - 6.3 & 9.8 BURNERS
 AO - AGO 15, 22.5 & 25.5 BURNERS
 (NOTE: SEE GUN ASSY FOR AO - 4.5, 6.3 & 9.8)
 COMPONENT PARTS

FIGURE 64
OIL STRAINER



SUCTION STRAINER:

118455-GO1 No. 2 Oil . . . sizes 2.1 thru 25.5
 118455-GO2 No. 4 & No. 6 Oil . . sizes 2.1, 4.5, 6.3 & 9.8
 118456-GO2 No. 4 & No. 6 Oil . . sizes 15, 22.5 & 25.5

DISCHARGE STRAINER:

118454-GO1 No. 6 Oil . . sizes 4.5 thru 25.5

COMPLETE ASSY.

Ref. No.	Part Number	Description	118454-GO1	118455-GO1	118455-GO2	118456-GO2
1	118438	Yoke	1			
2	118419	Yoke		1	1	
3	118434	Yoke				1
4	126258	Cap	1			
5	126259	Cap		1	1	
6	118433	Cap				1
7	118439	Body	1			
8	118418	Body		1	1	
9	118435	Body				1
10	354223-002	Strainer Basket				1
11	354223-003	Strainer Basket	1			
12	354223-005	Strainer Basket		1		
13	354223-006	Strainer Basket			1	
14	126260	Cap Gasket	1			
15	126261	Cap Gasket		1	1	
16	125502	Cap Gasket				1

PARTS AND PART NUMBERS AND REFERENCES.

Certain FIGURES in this manual Key various parts as follows 1, 2, 3, etc. For a detailed part description of the particular part number, refer to the "Parts and Part Number and Reference Numbers" page(s) in this manual. For a specific burner, refer to the index in

this manual for the FIGURE number. For quick reference, you will also note that air compressor, oil pump, electric oil heater, circulating valve, electric hi-low (Mag. Mod.) valve and oil strainer details and usages are listed individually in the index.

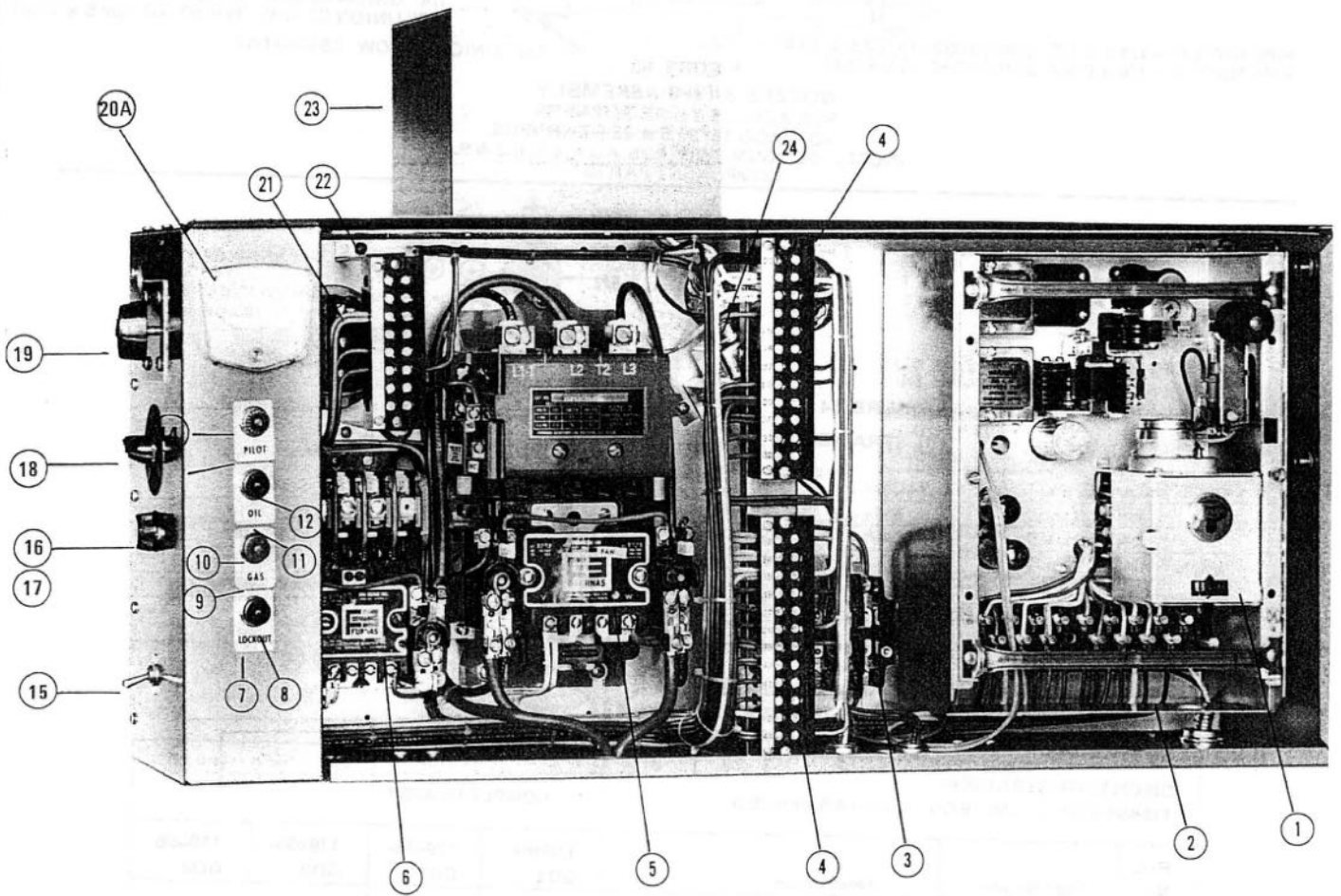

FIGURE 65

CONTROL PANEL (CABINET)

REF. NO.	PART NUMBER	DESCRIPTION OF PARTS ILLUSTRATED IN FIGURE 65
1	354426-002	Primary Combustion Control — Fireye UVC-2, Model 5065 - 115v. 60 cy.
1	354426-003	Primary Combustion Control — Fireye UVC-2, Model 5066 - 115v. 60 cy.
1	354571-003	Primary Combustion Control — Fireye PBC-5, Model 5022 - 115v. 60 cy.
1	354571-004	Primary Combustion Control — Fireye PBC-5, Model 5023 - 115v. 60 cy.
1	354217-001	Primary Combustion Control — Fireye 6058 — 115v. 60 cy.
1	354217-002	Primary Combustion Control - Fireye 6070-115v. 60 cy.
1	354217-005	Primary Combustion Control - Fireye 6080- 115v. 60 cy.
1	354217-006	Primary Combustion Control - Fireye 6580 - 115v. 60 cy.
1	354217-009	Primary Combustion Control - Fireye 4580 - 115v. 60 cy.
1	354195-001	Primary Combustion Control - Honeywell R-4126A1073 115v. 60 cy.
1	354195-002	Primary Combustion Control - Honeywell R-4127A1056 - 115v 60 cy.
1	354195-003	Primary Combustion Control - Honeywell R-4126A1172 - 115v. 60 cy.
1	354194-003	PbS Amplifier for Honeywell Controls
1	354194-004	U.V. Amplifier for Honeywell Controls
1	354194-006	Self check amplifier for Honeywell R-4126A.
2	354427-002	Mounting Frame for Fireye "C" Series Controls
2	354218-001	Mounting Frame for Fireye 6058
2	354218-002	Mounting Frame for Fireye 6070
2	354218-005	Mounting Frame for Fireye 6080
2	354218-008	Mounting Frame for Fireye 6580
2	354218-009	Mounting Frame for Fireye 4580
2	354196-001	Mounting Frame for Honeywell R-4126 & R-4127
3	354222-001	Electric Oil Heater Contactor 3 PST N.O. 115v. cy.
4	354205-002	Terminal Strip - 12 Pole - 60 amp
5	354202-007	Linestarter - Size 1½ - 3 Phase - 120v. 60 cy. coil
5	354202-008	Linestarter - Size 2 - 3 Phase - 120v. 60 cy. coil
5	354202-010	Linestarter - Size 2½ - 3 Phase - 120v 60 cy. coil
5	354202-011	Linestarter - Size 3 - 3 Phase - 120v. 60 cy. coil
6	354202-001	Linestarter - Size 00 - 1 Phase - 120v. 60 cy. coil
6	354202-002	Linestarter - Size 00 - 3 Phase - 120v. 60 cy. coil
6	354202-003	Linestarter — Size 0 - 1 Phase - 120v. 60 cy. coil
6	354202-004	Linestarter - Size 0 - 3 Phase - 120v. 60 cy. coil
6	354202-005	Linestarter - Size 1 - 1 Phase - 120v. 60 cy. coil
6	354202-006	Linestarter - Size 1 -3 Phase - 120v. 60 cy. coil
6	354202-009	Linestarter - Size 1½ - 1 Phase - 120v. 60 cy. coil
7	354022-002	Nameplate - Lockout
8	354049-004	Signal Light Assembly - Red Cap - 120v. 60 cy.
9	354022-005	Nameplate - Gas
10	354049-002	Signal Light Assembly - White Cap - 120v. 60 cy.
11	354022-004	Nameplate - Oil
12	354049-003	Signal Light Assembly - Amber Cap — 120v. 60 cy.
13	354022-003	Nameplate - Pilot
14	354049-001	Signal Light Assembly - Clear Cap - 120v. 60 cy.
15	85528	Control Circuit On-Off Switch — S.P.S.T.
16	86058	Fuse Holder - 250 V.A.C. - 15A
17	84843	Fuse - 15A
18	150010	Potentiometer - 300 ohm w/Dial Plate & Knob
19	86445	Fuel Transfer Switch - 4 PDT - 3 Position
19	133042	Fuel Transfer Switch - 6 PDT - 3 Position
19	136354	Fuel Transfer Switch - 7 PDT - 3 Position
20	84418	Voltmeter - 0-150 V.D.C. For Fireye PbS Combustion Controls
20	354468-001	Voltmeter 0-25 V.D.C. For Fireye U.V. Combustion Controls
20	84096	Microammeter 0-50 MA For Honeywell Combustion Controls
20A	89107	Voltmeter Leads
20A	CC-4140	Microammeter Leads
21	354229-010	Combustion Air Switch
22	354205-001	Terminal Strip - 8 Pole - 60 Amp
23	354228-001	Control Circuit Transformer - 208/220/440 v. PRI - 115v. Sec. 350 va.
23	354228-002	Control Circuit Transformer 208/220/440 v. PRI. 115 v. Sec. 500 va.
24	354208-010	Modulating Motor Transformer - 115v. PRI. ****
24	134701	2 Position Motor Transformer - 115v. PRI - (2.1 & 4.5 Burners Only* **)
*	132025	Panel Door Handle
**	132026	Panel Door Handle - Lock Type
**	136545	Alarm Bell - 4" - 115v. 60 cy.
**	136546	Alarm Horn - 115v. 60 cy.

* Standard Equip. Not Illus. ** Optional Equip. *** 2.1 & 4.5 Burner models prior to mid 1971

**** Optional Equip. with High-Low burners; also used with Modulation prior to Mid 1973.

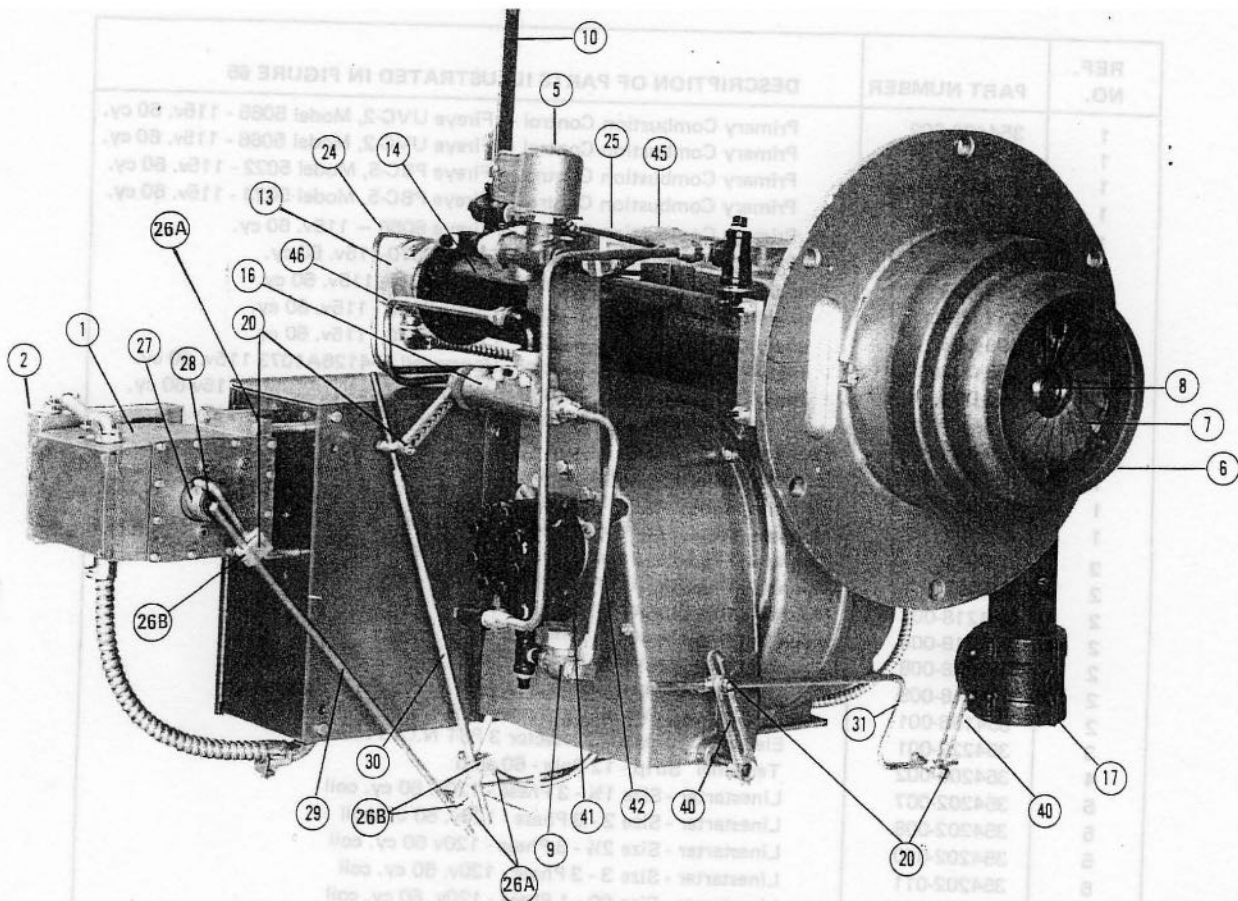

FIGURE 66 PAO & PAGO-(NO. 2,3,4 & 5 OIL)-2.1 & 4.5

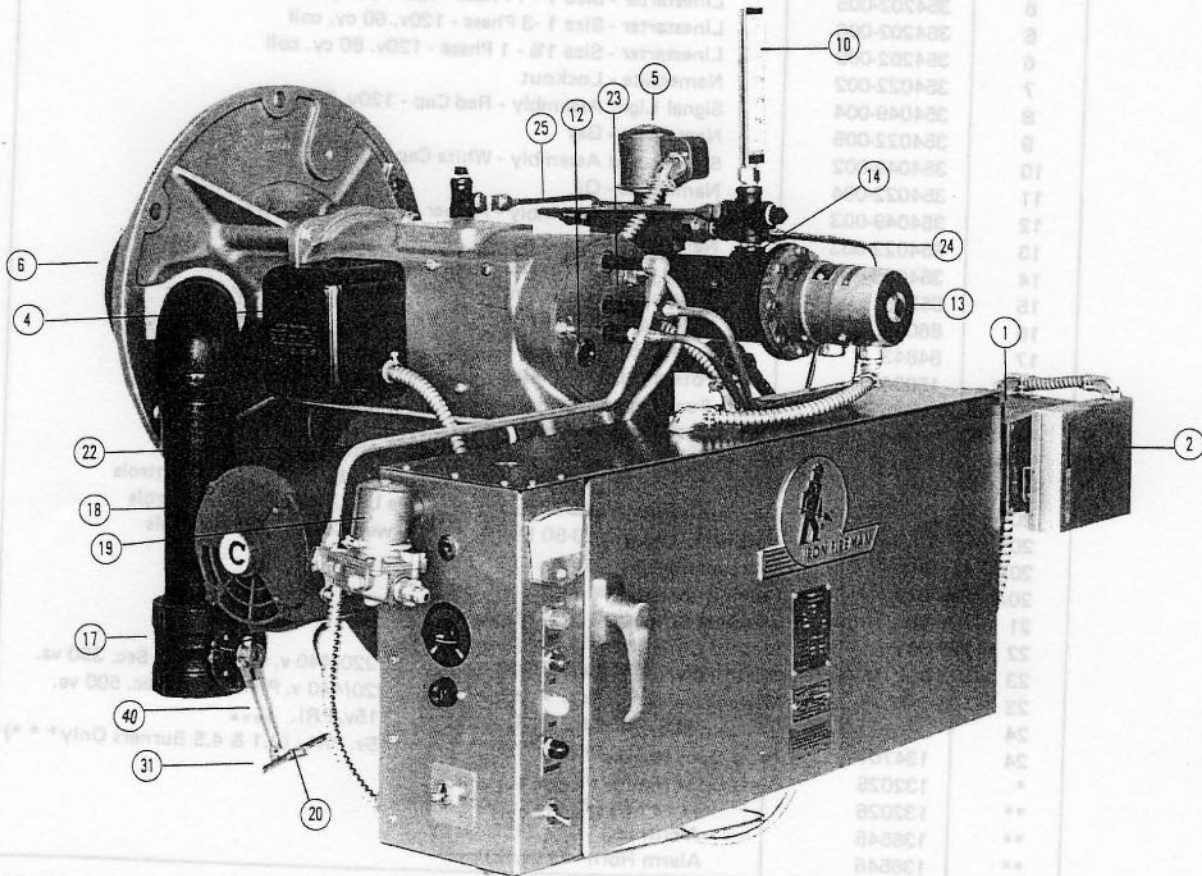

FIGURE 67 PAO & PAGO (NO. 2,3,4 & 5 OIL) 2.1 & 4.5

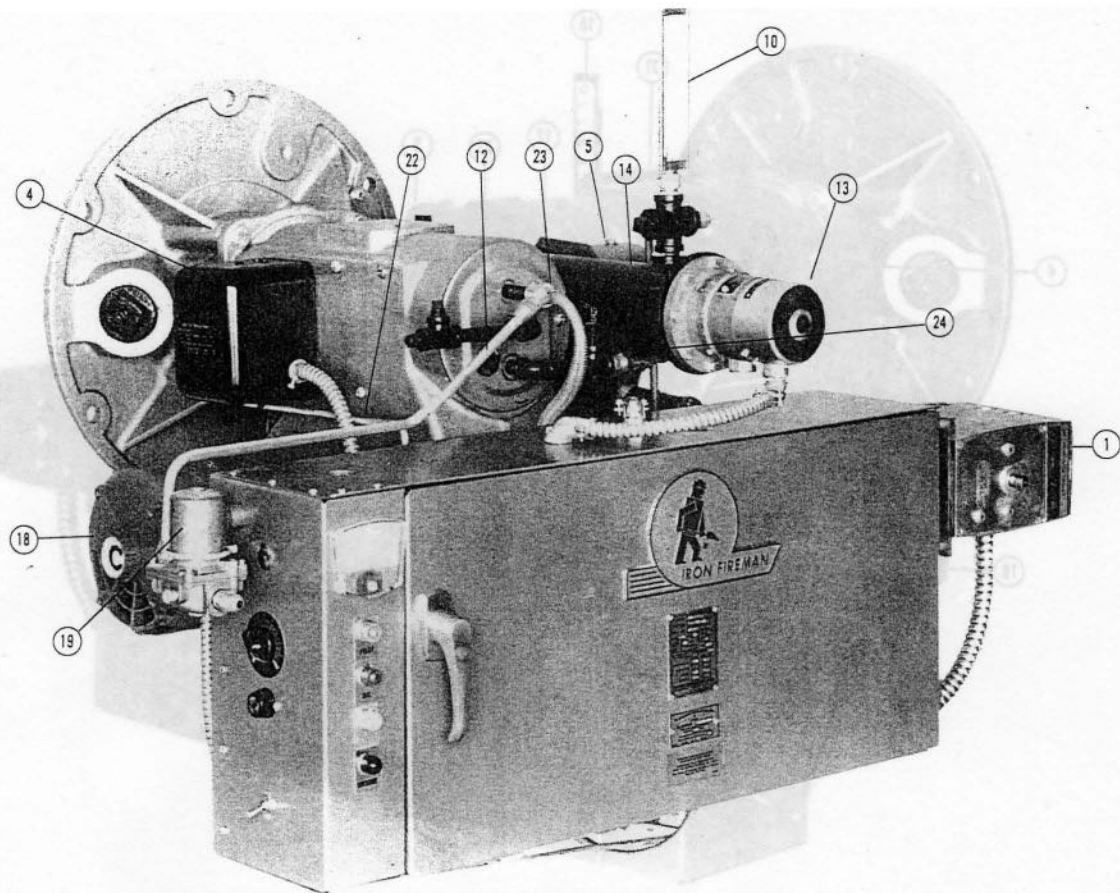

FIGURE 68 AO (NO. 2 & 4 OIL) 4.5

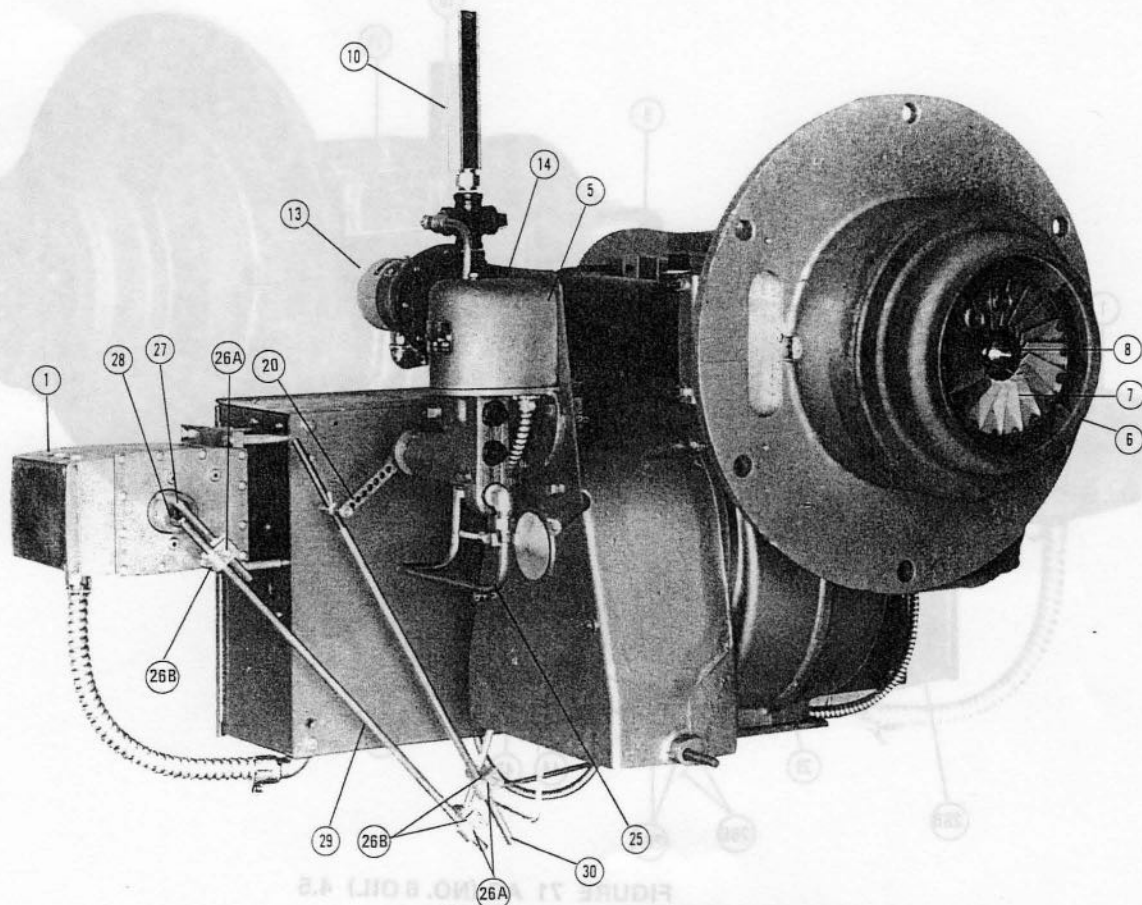

FIGURE 69 AO (NO. 2 & 4 OIL) 4.5

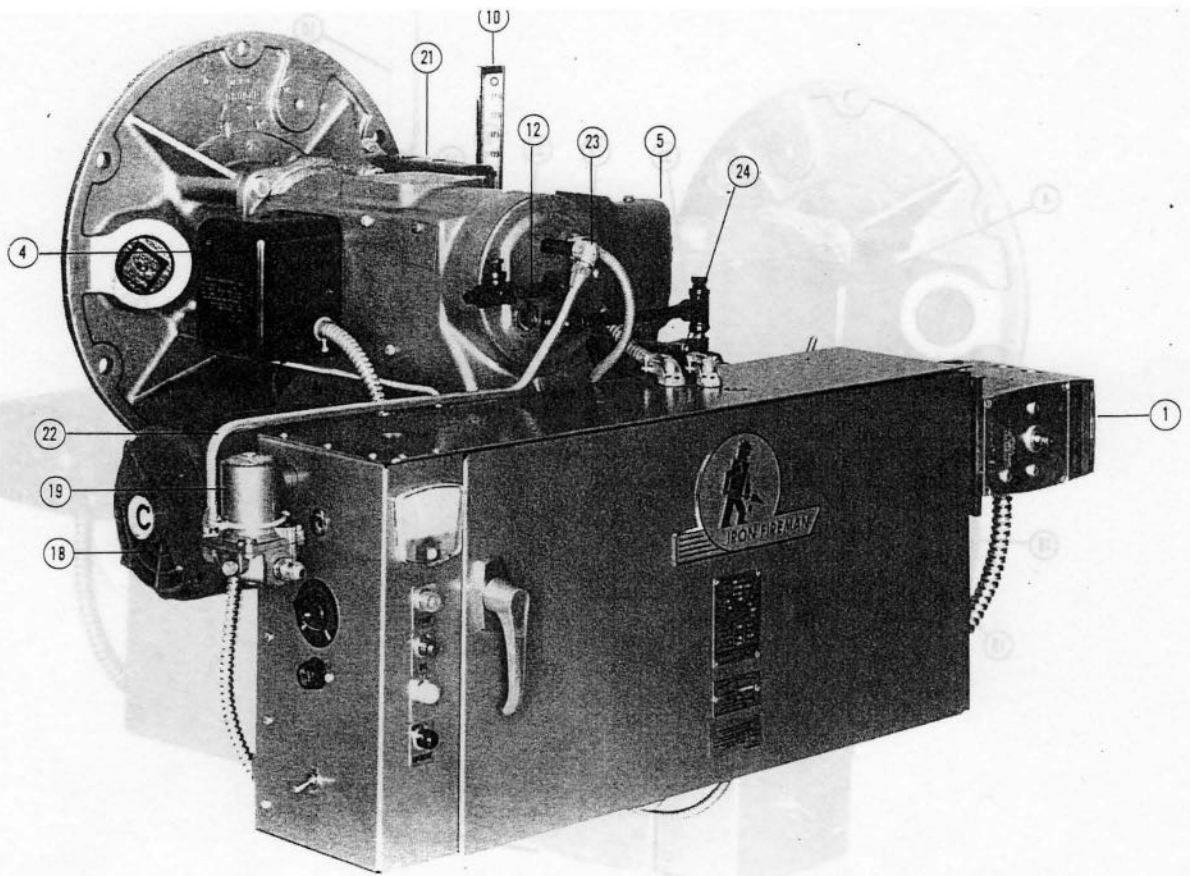

FIGURE 70 AO (NO. 6 OIL) 4.5

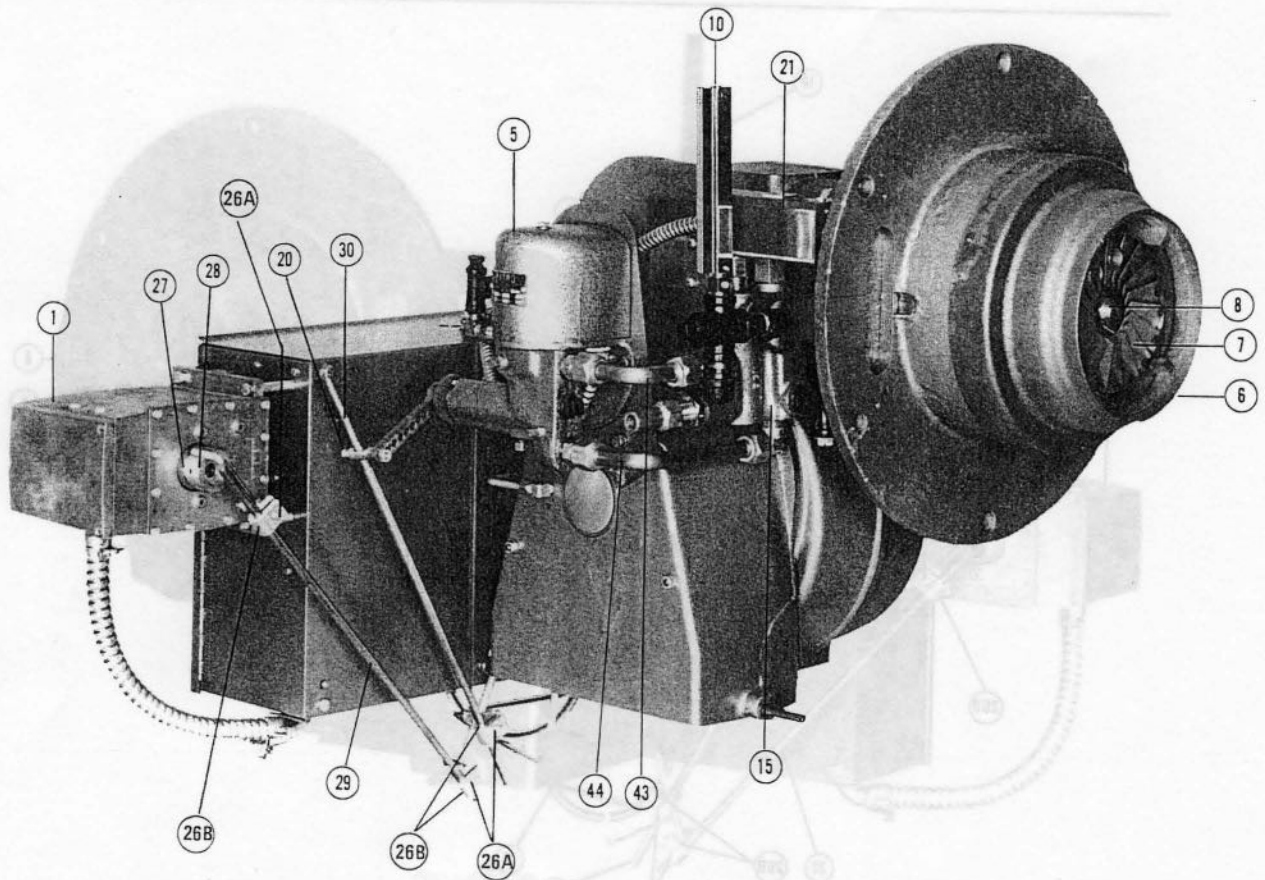

FIGURE 71 AO (NO. 6 OIL) 4.5

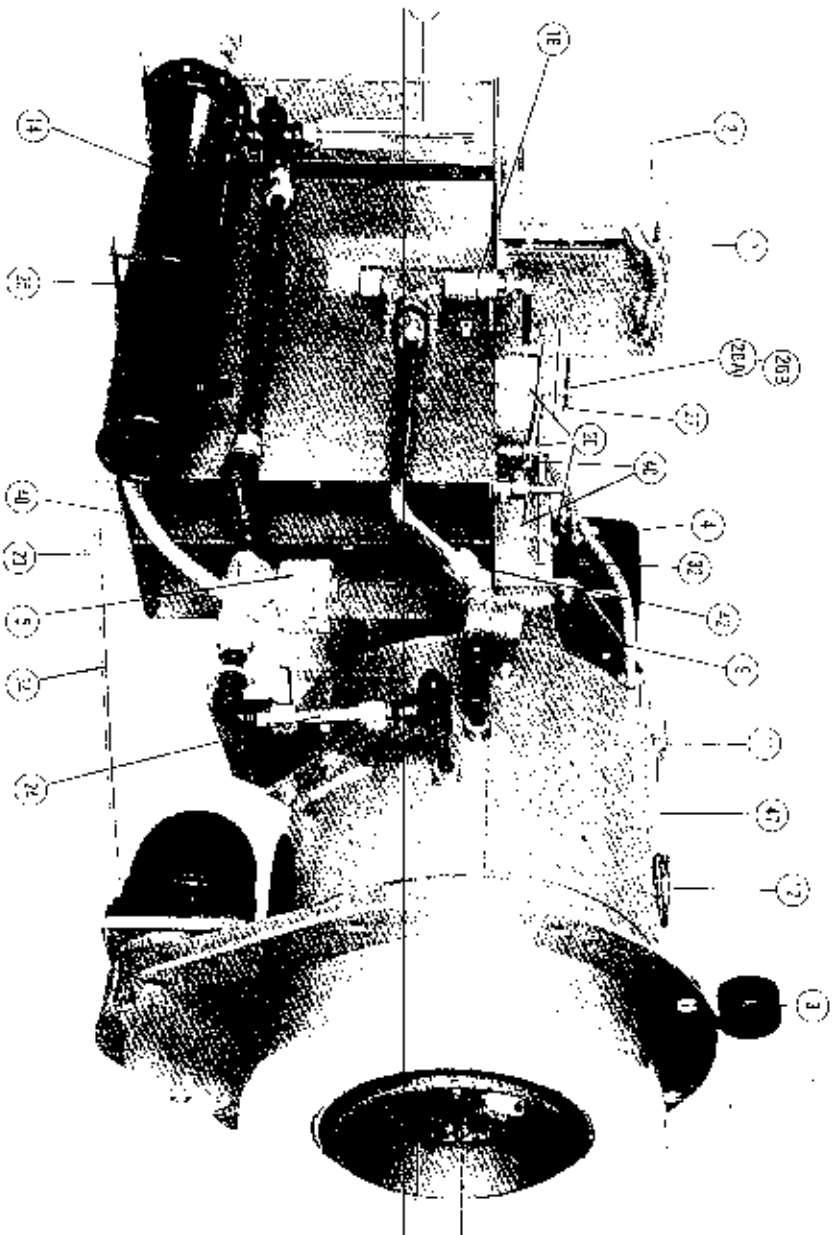
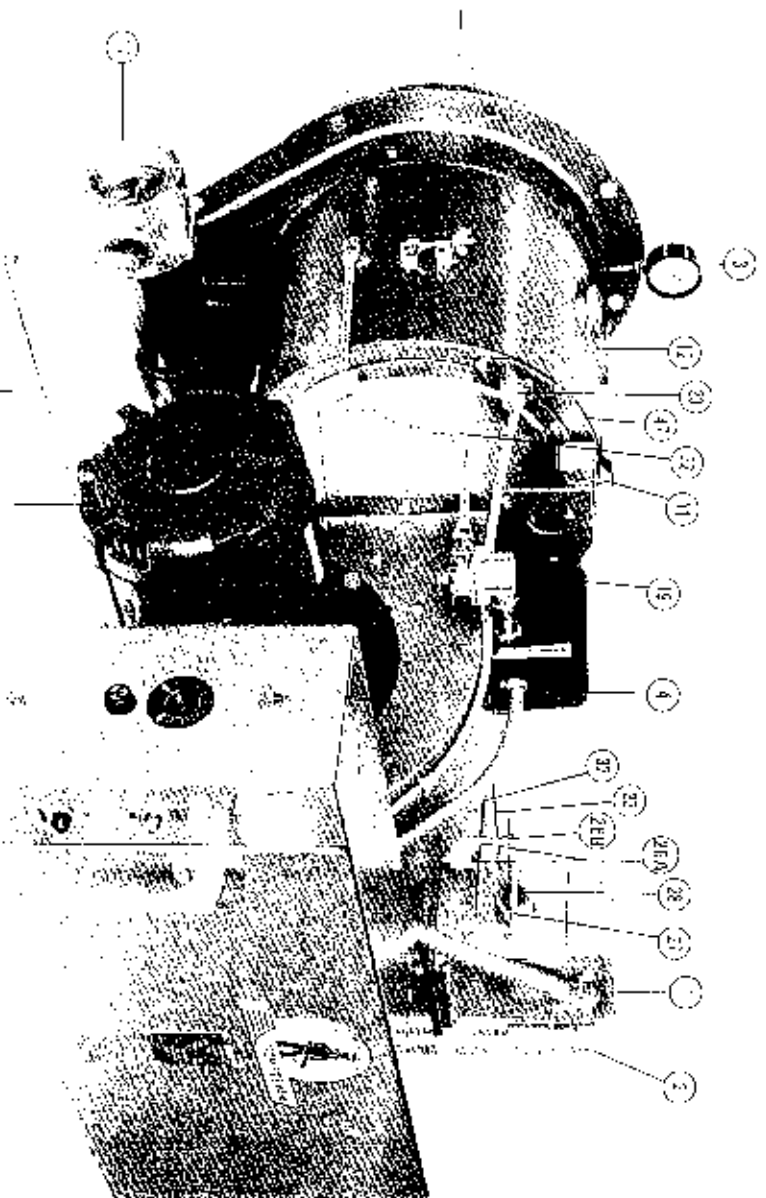

FIGURE 72

PAO & PAGO (NO. 2,3,4 & 5 OIL) 6.3 & 9.8



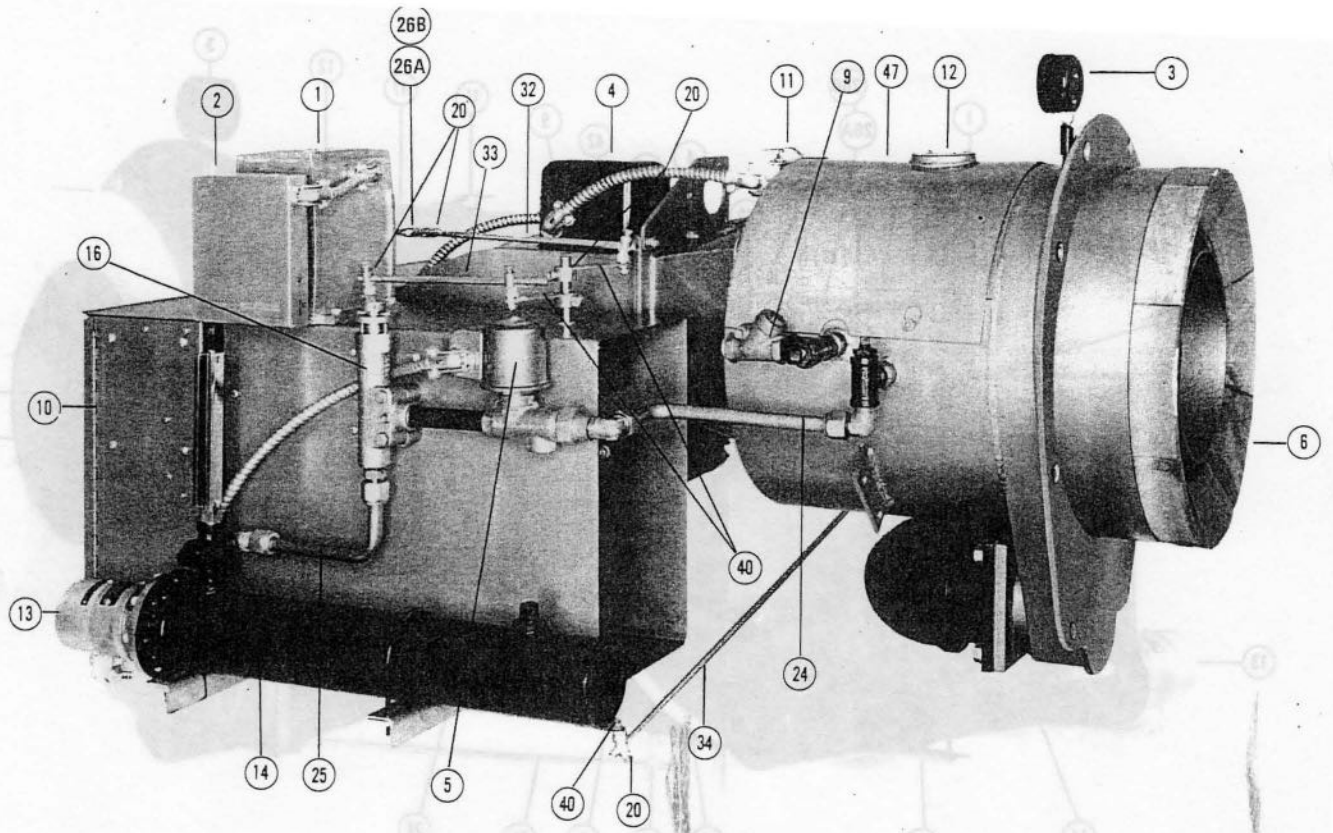
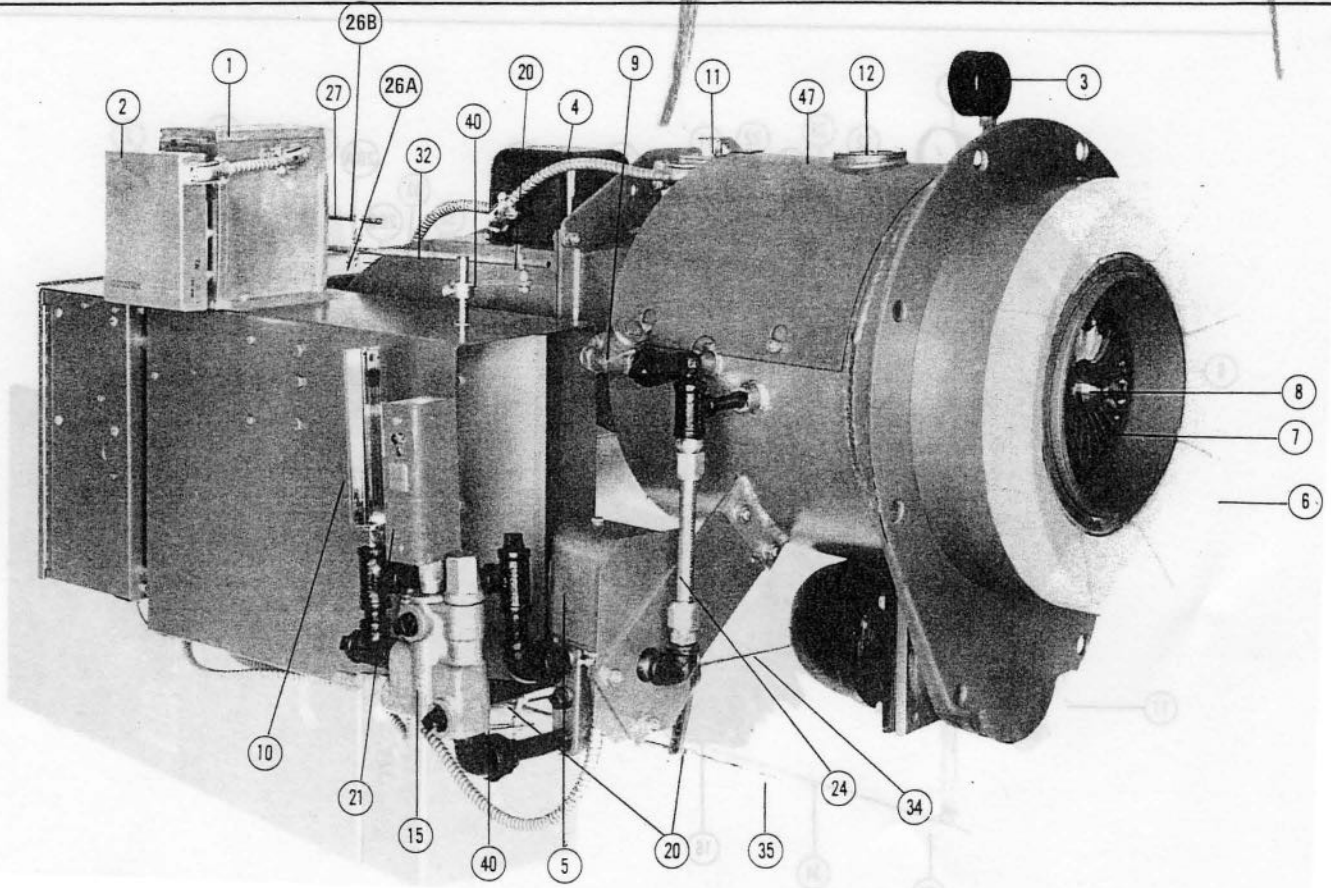

FIGURE 74 AO & AGO (NO. 2 & 4 OIL) 6.3 & 9.8



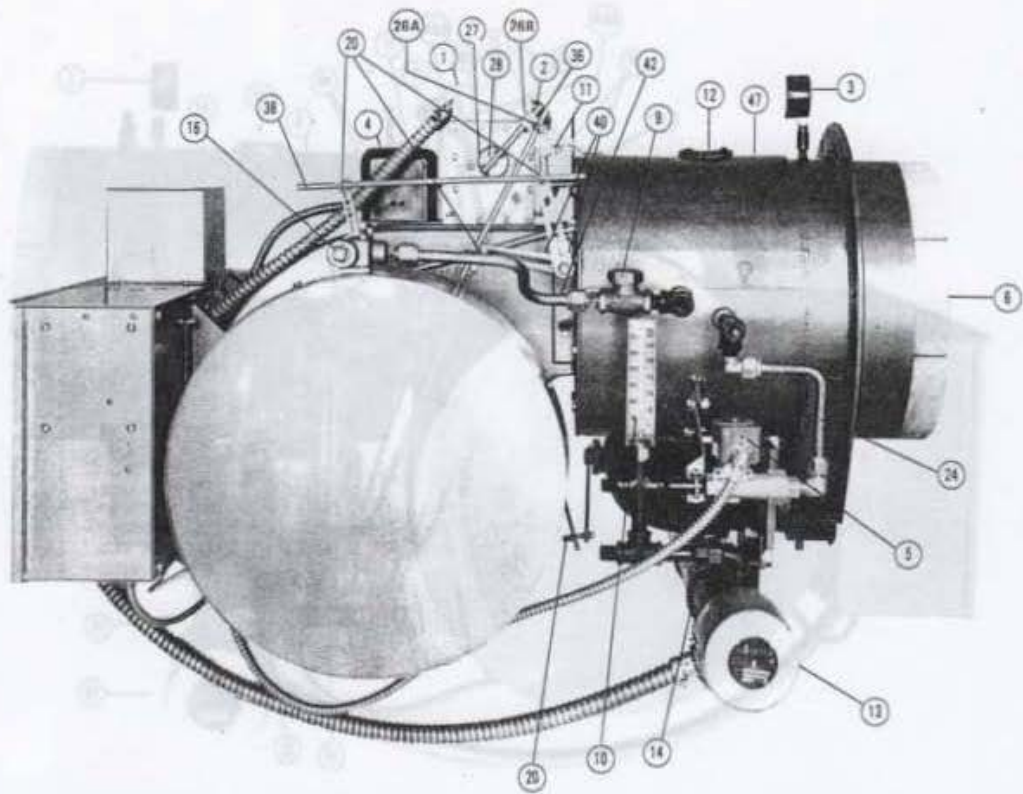

FIGURE 76 PAO & PAGO (NO. 2,3,4 & 5 OIL) 15

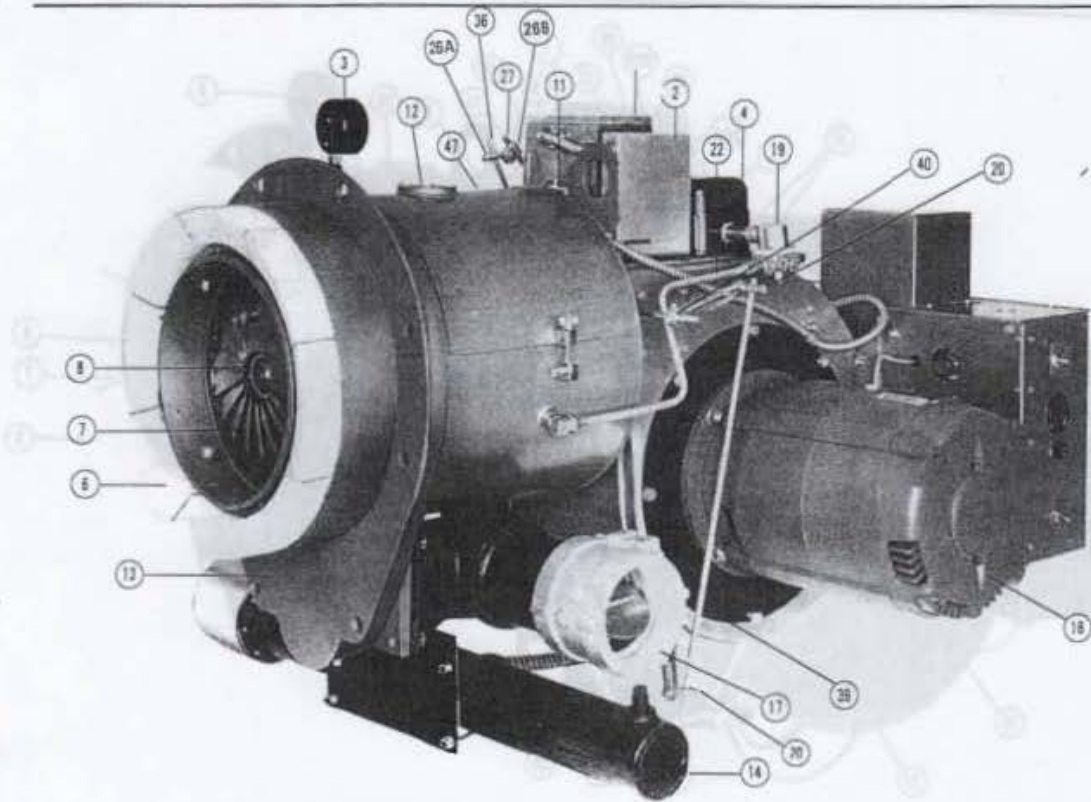

FIGURE 77 PAGO, AG, & AGO - (NO. 2 & 4 OIL) 15, 22.5, & 25.5

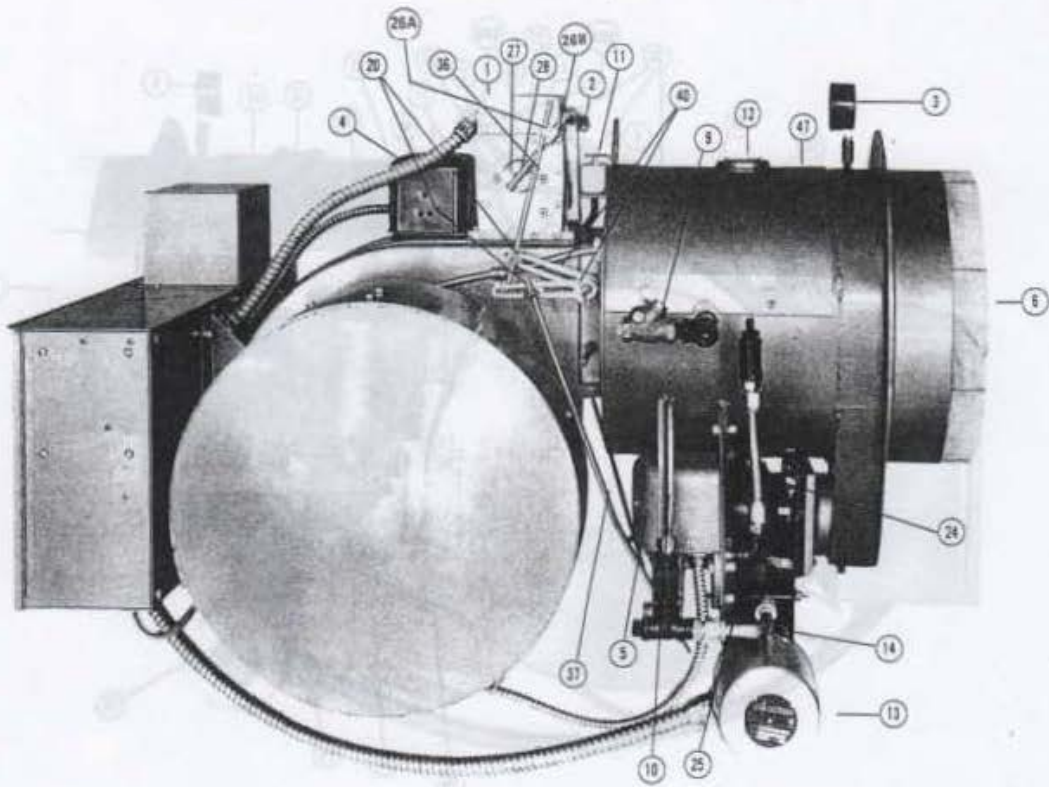

FIGURE 78 AO & AGO (NO. 2 & 4 OIL) 15, 22.5 & 25.5

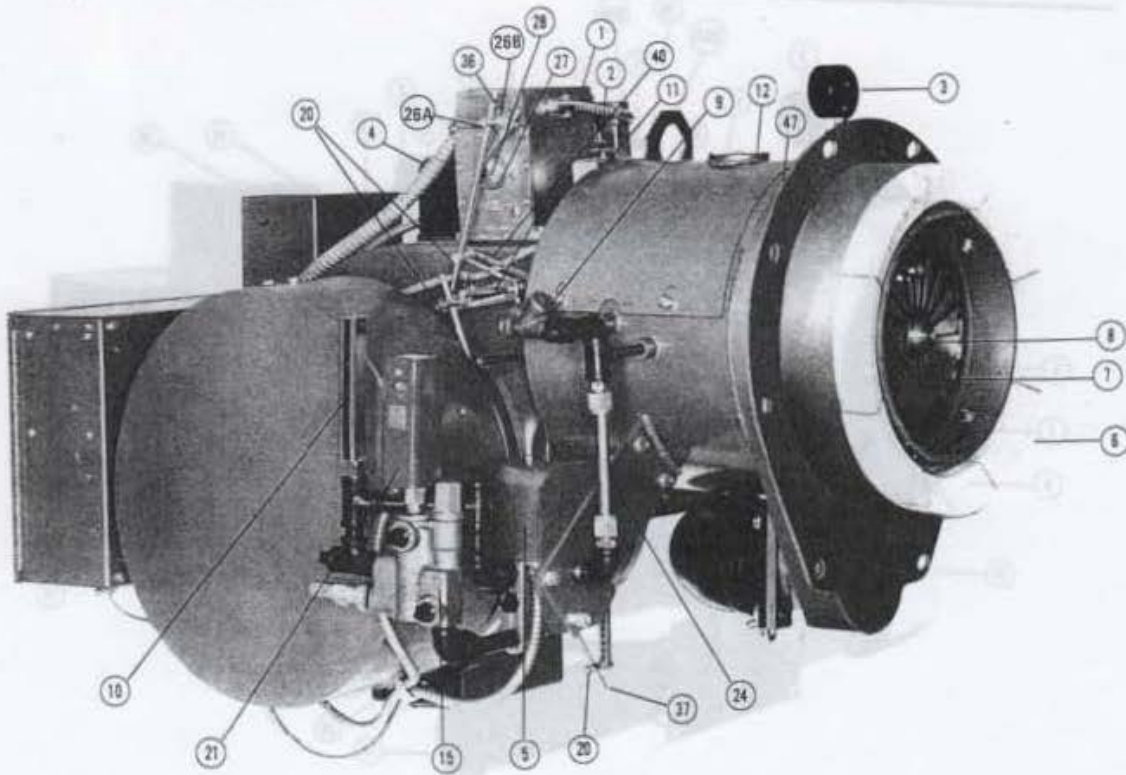

FIGURE 79 AO & AGO (NO. 6 OIL) 15, 22.5 & 25.5

REF. NO.	PART NUMBER	DESCRIPTION OF PARTS ILLUSTRATED IN FIGURES 66 THRU 79	USAGE REFERENCE
1	B421002-001	Modulating Motor W/1 Auxiliary Switch	Oil — U.L. Models
	B421002-002	Modulating Motor W/2 Auxiliary Switches	Gas & Gas Oil & F.M. & F.I.A. models
1	116970	Modulating Motor W/single End Switch *	All
	133164	2 Position Motor w/Dual End Switch	AO, PAO, PAGO - 2.1 & 4.5
2	354220-001	Auxiliary End Switch For Modulating Motor *	PAGO-AG-AGO
3	GB-5134	Gas Pressure Gauge 0-15" W.C.	All except 2.1 & 4.5
4	132614	Ignition Transformer 115v. P.R.I. 6000v. sec.	All
5		Oil Valve (Refer to Index & Figure 45)	All
6	144242	Refractory Sections	AO & PAO - 6.3 & 9.8
	143439	Refractory Sections	PAGO, AG, AGO - 6.3 & 9.8
	149251-001	Refractory Sections	AO & PAO - 15
	144722-001	Refractory Sections	PAGO, AG, & AGO - 15
	149335-001	Refractory Sections	All 22.5 & 25.5
	143881-GO1	Choke Ring — Standard	All 2.1 & 4.5
	144898-GO1	Choke Ring - Optional - Used for 18 G.P.H. or less	AO - 4.5
	149444-001	Choke Ring - Optional - Used in firebox boilers	PAO & PAGO - 2.1 & 4.5
7	144851-GO1	Diffuser Assembly	PAO - 2.1 & 4.5
	144805-GO1	Diffuser Assembly	PAGO - 2.1 & 4.5
	143889-GO1	Diffuser Assembly	AO - 4.5
	149258-GO1	Diffuser Assembly - Optional - Used for 18 G.P.H. or less	AO - 4.5
	149287-GO1	Diffuser Assembly	AO & PAO - 6.3 & 9.8
	143115-GO1	Diffuser Assembly	PAGO - AG & AGO - 6.3 & 9.8
	144540-GO1	Diffuser Assembly	AG & AGO-15
	149794-GO1	Diffuser Assembly	AO & PAO-15
	149785-GO1	Diffuser Assembly	AG, AO & AGO-22.5 & 25.5
8	145446-001	Nozzle - Monarch E180H 25GPH 80°	PAO & PAGO - 2.1
	145446-003	Nozzle - Monarch E180H 35 GPH 80°	PAO & PAGO - 4.5
	145446-005	Nozzle - Monarch E180H 55 GPH 80°	PAO & PAGO - 6.3
	145446-007	Nozzle - Monarch E180H 70 GPH 80°	PAO & PAGO - 9.8 (# 4 oil)
	145446-008	Nozzle - Monarch E180H 85 GPH 80°	PAO & PAGO - 9.8 (# 2 oil)
	145446-009	Nozzle - Monarch E180H 100 GPH 80°	PAO & PAGO - 15
	354377-001	Nozzle - Delevan 30615-43 50 GPH 100°	AO - 4.5
	142785	Nozzle - Monarch WA-169 80 GPH 100°	AO & AGO - 6.3 & 9.8
	354376-003	Nozzle - Monarch WA-169 100 GPH 100°	AO & AGO - 15
	354376-004	Nozzle - Monarch C-169 WA 150 GPH 100°	AO & AGO - 22.5 & 25.5
9	354444-001	Check valve	AO, PAO, & PAGO - 2.1 & 4.5
	354444-003	Check Valve	All except 2.1 & 4.5
10	111397	Thermometer	All No. 4 & 6 Oil
11	149390-GO1	Cover Switch Assembly	All 6.3 & 9.8
	149390-GO2	Cover Switch Assembly	All 15, 22.5 & 25.5
12	354274-004	Observation Glass	All 2.1 & 4.5
	354274-003	Observation Glass	All except 2.1 & 4.5
13		Electric Oil Pre-Heaters (Refer to Index)	All
14	143310-GO2	Heater Shell Assembly (No. 4 Oil)	All 2.1, 4.5, 6.3, & 9.8
	143310-GO1	Heater Shell Assembly (No. 4 Oil)	All 15, 22.5 & 25.5
15	118220-GO3	Circulating Valve (No. 6 Oil)	All
16		Modulating Oil Valves (Refer to Figures 43 & 45)	All
17	354288-GO1	Butterfly Valve — Iron Fireman 2" (see note)	Optional
	354288-GO2	Butterfly Valve — Iron Fireman 2½" (see note)	PAGO, AG, & AGO 2.1, 4.5 & 6.3
	354541-018	Butterfly Valve - North American 3" (see note)	Optional — 15 and 22.5
	354541-016	Butterfly Valve - North American 3" (see note)	PAGO, AG, & AGO - 9.8
	354541-017	Butterfly Valve - North American 4" (see note)	PAGO, AG & AGO - 15, 22.5 & 25.5
18	MM-1847-305	Motor - 2 H.P. 208/220/440 v. 60 cy. 3 Ph. 3450 RPM	All 2.1
	MM-1937-305	Motor - 3 H.P. 208/220/440 v. 60 cy. 3 Ph. 3450 RPM	All 4.5
	MM-2033-301	Motor - 5 H.P. 230/460v. 60 cy. 3 Ph. 3450 RPM	All - 6.3
	MM-2033-302	Motor - 5 H.P. 200v. 60 cy. 3 Ph. 3450 RPM	All - 6.3
	MM-2131-301	Motor - 7½ H.P. 230/460v. 60 cy. 3 Ph. 3450 RPM	All - 9.8
	MM-2131-302	Motor - 7½ H.P. 200v. 60 cy. 3 Ph. 3450 RPM	All - 9.8
	MM-2401-301	Motor - 15 H.P. 230/460v. 60 cy. 3 Ph. 3450 RPM	All 15
	MM-2401-302	Motor - 15 H.P. 200v. 60 cy. 3 Ph. 3450 RPM	All 15
	MM-2600-301	Motor - 20 HP 230/460 v 60 cy. 3 Ph 3450 RPM	All - 22.5
	MM-2600-302	Motor - 20 HP 200v 60 cy. 3 Ph. 3450 RPM	Optional All 22.5
	MM-2700-301	Motor - 25 HP 230/460v 60 cy. 3 Ph 3450 RPM	All - 25.5
	MM-2700-302	Motor - 25 HP 200 v 60 cy. 3 Ph 3450 RPM	Optional All - 25.5
19	354057-001	Gas Pilot Solenoid Valve ½ P.S.I. 3/8" 120v 60 cy.	All 2.1 & 4.5
	354057-006	Gas Pilot Solenoid Valve ½ P.S.I. 3/8" 120v 60 cy.	All except 2.1 & 4.5
	354057-008	Gas Pilot Solenoid Valve 5 P.S.I. 3/8" 120v 60 cy.	Optional - All
	354057-011	Gas Pilot Solenoid Valve ½ P.S.I. ½" 120 v 60 cy.	Optional - All
	354057-014	Gas Pilot Solenoid Valve 6 P.S.I. ½" 120v 60 cy.	Optional - All
20	354142-005	Swivel	All
21	131527	Cold Oil Temperature Control Switch (No. 6 Oil)	All
22	144551-GO3	Gas Pilot Tube Assembly	PAO & PAGO - 2.1 & 4.5
	149020-GO1	Gas Pilot Tube Assembly	AO - 4.5
	142968-GO1	Gas Pilot Tube Assembly	All 6.3 & 9.8
	145482-GO2	Gas Pilot Tube Assembly	All 15, 22.5 & 25.5
23	354209-003	Lead Sulfide Scanner (Used w/Fireye "P" Series PbS Controls)	All
	354209-011	Lead Sulfide Scanner (Used w/Fireye "C" Series PbS Controls)	All
	354418-005	Ultra Violet Scanner (Used w/Fireye "C" Series U-V Controls)	All

Note: When available gas pressure is 1 psig or more, valve furnished, or used, should be one iron pipe size smaller for 2.1, 4.5, 9.8, 15 and 22.5 burner sizes.

* used with Modulating Burners prior to Mid 1973

REF. NO.	PART NUMBER	DESCRIPTION OF PARTS ILLUSTRATED IN FIGURES 66 THRU 79	USAGE REFERENCE
23	354418-001 354418-004 354227-003 354206-003 354215-001	U. V. Scanner (Used w/Fireye 6580 Control) U. V. Scanner (used w/Fireye 4580 Control) Lead Sulfide Cell Holder (Used w/Honeywell PbS Controls) Lead Sulfide Cell (Used w/Honeywell PbS Controls) U. V. Cell & Mount (Used w/Honeywell R-4126 U. V. Control) U. V. Cell & Mount (Used w/Honeywell R-4126 U. V. Control)	Optional Optional Optional Optional Optional Optional
24	144906-GO1 143813-GO1 144256-GO3 142985-GO1 144551-G10 144256-GO1	Oil Valve Tube Assembly Oil Valve Tube Assembly Oil Valve Tube Assembly Oil Valve Tube Assembly (No. 2 & 4 Oil) Oil Valve Tube Assembly Oil Valve Tube Assembly (No. 6 Oil AO & AGO - 6.3 & 9.8)	PAO & PAGO - 2.1 & 4.5 AO - 4.5 PAO & PAGO - 6.3 & 9.8 AO & AGO - 6.3 & 9.8 PAO & PAGO - 15 AO & AGO - 15, 22.5 & 25.5
25	144551-G19 149309-GO1 144551-G11 144551-G10	Tube Assembly - Heater to Valve (No. 4 Oil) Tube Assembly - Heater to Valve (No. 4 Oil) Tube Assembly - Heater to Valve (NO. 4 Oil) Tube Assembly - Heater to Valve (No. 4 Oil)	PAO & PAGO - 2.1 & 4.5 AO - 4.5 PAO & PAGO - 6.3 & 9.8 AO & AGO - 6.3 & 9.8 -All 15, 22.5 & 25.5
26A	354142-007	Swivel	All
26B	139828	Linkage Swivel Block	All
27	142303 149614-GO1	Collar & Arm Assembly Collar & Arm Assembly	All 2.1 & 4.5 All except 2.1 & 4.5
28	130393 133386	Modulating Motor Bushing 2 Position Motor Bushing	All Optional - 2.1 & 4.5
29	354131-004	Linkage Rod 3/8"	All - 2.1 & 4.5
30	143906	Linkage Rod 3/8" to 5/16"	All - 2.1 & 4.5
31	354126-020	Linkage Rod 5/16"	PAGO - 2.1 & 4.5
32	354126-009	Linkage Rod 5/16"	All - 6.3 & 9.8
33	354126-005	Linkage Rod 5/16" (No. 2 & 4 Oil ONLY)	All - 6.3 & 9.8
34	354126-012	Linkage Rod 5/16" (Gas & Gas/Oil ONLY)	All - 6.3 & 9.8
35	354126-009	Linkage Rod 5/16" (No. 6 Oil ONLY)	All - 6.3 & 9.8
36	354126-006	Linkage Rod 5/16"	All - 15, 22.5 & 25.5
37	149267-001	Linkage Rod 5/16"	AO - 15, 22.5 & 25.5
38	354126-009	Linkage Rod 5/16"	PAO - 15
39	354126-011	Linkage Rod 5/16" (Gas & Gas Oil Only)	All - 15, 22.5 & 25.5
40	354419-003 354419-004	Linkage Crank Arm - Short Linkage Crank Arm - Long	All - 6.3 & 9.8 All except 6.3 & 9.8
41	133163 149496-GO1	Oil Pump (No. 2 Oil Only) Oil Pump (No. 4 Oil Only) For other oil pumps refer to Figures 41, 53, & 54	PAO & PAGO - 2.1 & 4.5 PAO & PAGO - 2.1 & 4.5 All
42	144551-GO9 144551-G10 145482-GO1	Tube Assembly - Modulating Valve to Check Valve Tube Assembly - Modulating Valve to Check Valve Tube Assembly - Modulating Valve to Check Valve	PAO & PAGO - 2.1 & 4.5 PAO & PAGO - 6.3 & 9.8 PAO & PAGO - 15
43	117632	Tube Assembly - Modulating Valve to Circulating Valve	AO - 4.5 (No. 6 Oil Only)
44	144551-GO4	Tube Assembly - Modulating Valve To Circulating Valve	AO - 4.5 & (No. 6 Oil Only)
45	144871-GO1	Tube Assembly - Oil Pump to Electric Heater (No. 4 Oil Only)	PAO & PAGO - 2.1 & 4.5
46	149393-GO1	Tube Assembly - Modulating Valve to Nozzle Return Line	PAO & PAGO - 2.1 & 4.5
47	142838-001	Housing Cover Assembly	All except 2.1 & 4.5
Items Not Illustrated			
	142255 132525 142787 142786 145433-GO1 145433-GO2 149133-GO1 149440-GO1 149578-GO1 149134 133162 354186-019 354186-016 354186-022 131526 354448-001 142987-GO1 144991-GO1 144714-GO1 354057-063	Fan Assembly - 8-1/4 Dia. X 5-1/2" wide - 5/8" Bore Fan Assembly - 9-1/8 Dia. X 5-1/2" wide - 5/8" Bore Fan Assembly - 10-3/4 Dia. X 2-1/2" wide - 1-1/4" Bore Fan Assembly - 10-3/4 Dia. X 3-1/2" wide - 1-1/4" Bore Fan Assembly - 12-1/4 Dia. X 5" wide - 1-3/8" Bore Fan Assembly - 12-1/4 Dia. X 6" wide - 1-3/8" Bore Choke Band (Optional) Choke Band (Optional) Choke Band (Optional) Choke Band Support (Optional) Gas/Oil Only Oil Pump Coupling Low Oil Pressure Switch (Optional - PAO & PAGO Burners) Low Oil Pressure Switch (Optional - AO & AGO Burners) Low Oil Pressure Switch (Optional - AO & AGO Burners) High Oil temperature Switch (Optional No. 4 & 6 Oil Only) High Gas Pressure Switch (Optional Gas & Gas/Oil) Bus Bar Assembly Bus Bar Assembly Bus Bar Assembly N.O. Oil Valve (Optional, Models prior to Mid 1972)	All - 2.1 All - 4.5 All - 6.3 All - 9.8 All - 15 All - 22.5 & 25.5 All - 6.3 & 9.8 All - 15 All - 22.5 & 25.5 All - 6.3 & 9.8 PAO & PAGO - 2.1 & 4.5 All AO - 4.5, 6.3, & 9.8 AO - 15, 22.5, & 25.5 All All AG & PAGO & AGO - 6.3 & 9.8 AO - PAO - 6.3 & 9.8 All - 15 & 22.5 & 25.5 Optional