

**MULTI POSITION
2- STAGE
GAS FURNACES**



**Service
Manual**



***9MPT & *9MPV
“A1 & A2”**

This manual supports condensing gas furnaces manufactured in 2001

Manufactured by:



**Part Number
440 08 2002 02**

***9MPT - Dual Certified Venting (1 or 2 pipes)**

***9MPV - Dual Certified Venting (1 or 2 pipes)
Variable Speed**

TABLE OF CONTENTS

1. INTRODUCTION	2
2. UNIT IDENTIFICATION	2
3. FURNACE THEORY OF OPERATION	3
4. ELECTRICAL SUPPLY	4
5. INTERLOCK SWITCH	5
6. GAS SUPPLY	5
7. L.P. PRESSURE SWITCH	7
8. HIGH ALTITUDE OPERATION	7
9. BURNERS	7
10. CHECKING TEMPERATURE RISE	8
11. ROOM THERMOSTATS	9
12. CONTROL WIRING	10
13. LIMIT SWITCHES	10
14. PRESSURE SWITCHES	12
15. VENT/COMBUSTION AIR PIPING	13
16. STANDARD VENT TERMINATION	14
17. CONCENTRIC VENT TERMINATION	16
18. EXHAUST BLOWER	17
19. CONDENSATE DRAIN TRAP	17
20. HONEYWELL ST9162A FAN TIMER/FURNACE CONTROL	18
21. ST9162A/SV9541Q TESTING SEQUENCE	19
22. HONEYWELL SV9541Q 2-STAGE GAS VALVE/IGNITION SYSTEM	19
23. HONEYWELL SV9541Q SYSTEM OPERATION	20
24. CHECKING FLAME CURRENT	22
25. CAPACITORS	22
26. BLOWER ASSEMBLY	22
27. BLOWER ROTATION	27
28. HEAT EXCHANGER REMOVAL/REPLACEMENT	38
SV9541Q "SMART VALVE" - Sequence of Operation	39
SV9541Q "SMART VALVE" - Trouble shooting	40
SV9541Q "SMART VALVE" - Electrical Variation	42
TECHNICAL SERVICE DATA (N9MPV)	44
BLOWER PERFORMANCE DATA (*9MPV)	45
TECHNICAL SERVICE DATA (*9MPT)	52
BLOWER PERFORMANCE DATA (*9MPT)	53
WIRING DIAGRAM (*9MPV)	54
WIRING DIAGRAM (*9MPT)	58
APPENDIX OF HELPFUL INFORMATION	60

1. INTRODUCTION

This service manual is designed to be used in conjunction with the installation manual and/or technical support manual provided with each furnace.

These furnaces represent the very latest in high efficiency gas furnace technology. Consequently, they incorporate the use of certain controls that contain highly sophisticated electronic components which are **not user serviceable**. therefore, it is essential that only competent, qualified, service personnel attempt to install, service, or maintain this product.

This Service manual was written to assist the professional HVAC service technician to quickly and accurately diagnose and repair any malfunction of this product.

This service manual covers several different models in two (2) families of our new multi-position furnaces; Variable Speed (D.C. - Blower Motor) models in the Condensing furnace family, and 2 speed (P.S.C.-Blower Motor) models in both the Condensing and Non-Condensing furnace families. The overall operation of all of these models and families is essentially the same, with the exception of the Blower Motor, and/or certain control functions which may be unique to a particular model and/or family.

This manual, therefore, will deal with all subjects in a general nature (I.E. all text will pertain to all models) unless that subject is unique to a particular model or family, in which case it will be so indicated.

Throughout the manual references may be made to "VARIABLE SPEED MODELS" as well as "TWO SPEED MOD-

ELS". GENERALLY, the distinction between these two groups is based on a difference in the type of Blower Motor used. These may not be the only differences, however, and the differences may vary from model to model within a particular family or series.

It will be necessary then for you to accurately identify the unit you are servicing, so you may be certain of a proper diagnosis and repair. (See Unit Identification, Page 3)

⚠ WARNING

The information contained in this manual is intended for use by a qualified service technician who is familiar with the safety procedures required in installation and repair and who is equipped with the proper tools and test instruments.

Installation or repairs made by the unqualified persons can result in hazards subjecting the unqualified person making such repairs to the risk of injury or electrical shock which can be serious, or even fatal not only to them, but also to persons being served by the equipment.

If you install or perform service on equipment, you must assume responsibility for any bodily injury or property damage which may result to you or others. We will not be responsible for any injury or property damage arising from improper installation, service and/or service procedures.

2. UNIT IDENTIFICATION

The unit's rating plate contains important information for the service technician. It also lists the complete Model Manufacturing and Serial Numbers.

These complete numbers are required to obtain correct re-

placement parts (example, in certain model families a unit having a MARKET REVISION of "C" is likely to be equipped with one or more different components.

MODEL NUMBER IDENTIFICATION GUIDE

<p>Brand Identifier T = Tempstar N = Neture C = Comfortmaker/Keeprite H = Heil/Arcoaire X = Evaluation</p> <p>Brand Identifier 8 = Non-Condensing, 80+% Gas Furnace 9 = Condensing, 90+% Gas Furnace</p> <p>Installation Configuration UP = Upflow DN = Downflow UH = Upflow/Horizontal HZ = Horizontal DH = Downflow/Horizontal MP = Multiposition, Upflow/Downflow/Horizontal</p> <p>Major Design Feature 1 = One (Single) Pipe L = Low NOx T = Two Stage 2 = Two Pipe N = Single Stage V = Variable Speed D = 1 or 2 Pipe P = PVC Vent</p>	9	M P	T	0 7 5	B	1 2	A	1	<p>Engineering Rev. Denotes minor changes</p> <p>Marketing Digit Denotes minor change</p> <p>Cooling Airflow 08 = 800 CFM 12 = 1200 CFM 14 = 1400 CFM 16 = 1600 CFM 20 = 2000 CFM</p> <p>Cabinet Width B = 15.5" Wide F = 19.1" Wide J = 22.8" Wide L = 24.5" Wide</p> <p>Input (Nominal MBTUH)</p>
--	----------	------------	----------	--------------	----------	------------	----------	----------	---

Figure 1 Component Locations for Four Position Furnaces

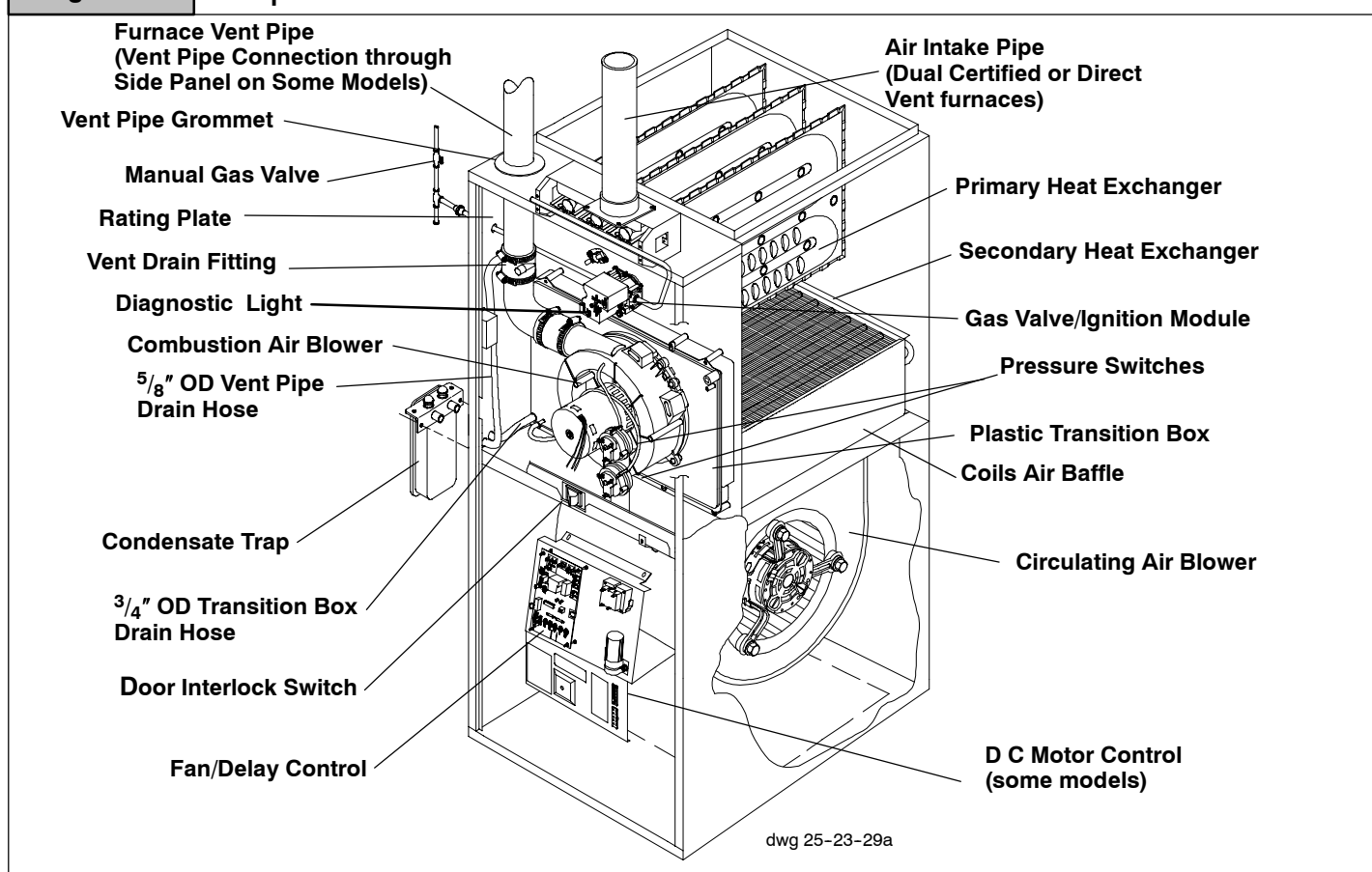

3. FURNACE THEORY OF OPERATION

The high efficiencies and lower profile (compared to previous series) of this furnace have been obtained using design techniques not typical of traditional furnace designs. A brief description of these new design techniques and the purpose they serve follows.

1. Reducing the height of the furnace while maintaining the high efficiency of previous models required working the heat exchanger more efficiently and yet minimizing the overall size.

The design required to achieve these results is the "SERPENTINE" design, wherein the flue gasses must follow a serpent shaped passage through the heat exchanger via convection.

This "Serpentine" path is resistive to normal convective flow, and requires that a partial vacuum be created at the outlet of the heat exchanger to maintain the flow of flue products through the heat exchanger.

2. The serpentine heat exchanger design does not lend itself well to the ribbon type, or slotted port type burner found in more traditional design furnaces for the following reasons:

A. The secondary combustion airflows at right angles to the burner flame, making it likely to "pull" the flame off a ribbon or slotted port type burner.

B. The flame "height" of a ribbon or slotted port type burner would make it difficult (if not impossible) to prevent impingement of the flame on the heat exchanger surfaces while maintaining the low profile heat exchanger.

For these reasons, an "INSHOT" type burner is used in this series. The inshot burner (also called a "jet" burner) fires a flame straight out its end. This burner is designed to fire into a tube style heat exchanger, making it an ideal application in the tube-like passages of the serpentine heat exchanger.

3. In order to extract the maximum amount of heat possible from the flue gasses, a secondary heat exchanger (condenser) is connected to the outlet of the primary heat exchanger. This condenser removes additional heat from the flue gasses, causing their temperature to drop below dew point, thus increasing operating efficiency of the furnace, and the term "*Condensing Furnace*". This results in the forming of condensation (water) which then must be routed to a drain.
4. The placement of the secondary heat exchanger at the outlet of the primary heat exchanger creates additional resistance to the flow of gasses.
5. To overcome the resistance to convective flow of the Primary and Secondary heat exchangers requires the use of an Induced Draft Combustion Blower Assembly.

6. The Combustion Blower Assembly is mounted on the outlet side of the Secondary heat exchanger, This blower creates a partial vacuum (negative pressure) within the heat exchangers drawing the flue products out of the furnace.

7. The Combustion Blower Assembly is mounted on the outlet side of the Secondary heat exchanger, This blower creates a partial vacuum (negative pressure) within the heat exchangers drawing the flue products out of the furnace.

4. ELECTRICAL SUPPLY

⚠ WARNING

Electrical shock hazard.

Turn OFF electric power at fuse box or service panel before making any electrical connections and ensure a proper ground connection is made before connecting line voltage.

Failure to do so can result in death, personal injury and/or property damage.

SUPPLY CIRCUIT

The furnace cannot be expected to operate correctly unless it is properly connected (wired) to an adequately sized (15 amp.) single branch circuit.

SUPPLY VOLTAGE

Supply voltage to the furnace should be a nominal 115 volts. It MUST be between 97 volts and 132 volts. Supply voltage to the furnace should be checked WITH THE FURNACE IN OPERATION. Voltage readings outside the specified range can be expected to cause operating problems. Their cause MUST be investigated and corrected.

ELECTRICAL GROUND

Grounding of the electrical supply to ALL FURNACES IS REQUIRED for safety reasons.

POLARITY

CORRECT POLARITY of the line voltage supply to all furnaces is also REQUIRED for safety reasons.

CHECKING GROUNDING AND POLARITY

Grounding may be verified as follows:

1. Turn the power supply "OFF".
2. Using an **Ohmmeter** check for continuity between the Neutral (white) wire and Ground wire (green) of the supply circuit.
3. With the Ohmmeter set on the R x 1 scale, the reading should be **zero Ohms**.
4. A zero Ohm reading indicates that the neutral is grounded back to the main panel.

5. An alternate check would be to check for continuity from the Neutral to a cold water pipe, (Pipe must be metal, and must have a continuous, uninterrupted connection to ground) or to a continuous, uninterrupted connection to ground) or to a driven ground rod.
6. Any **readings other than zero Ohms** would indicate a poor ground, or no ground.

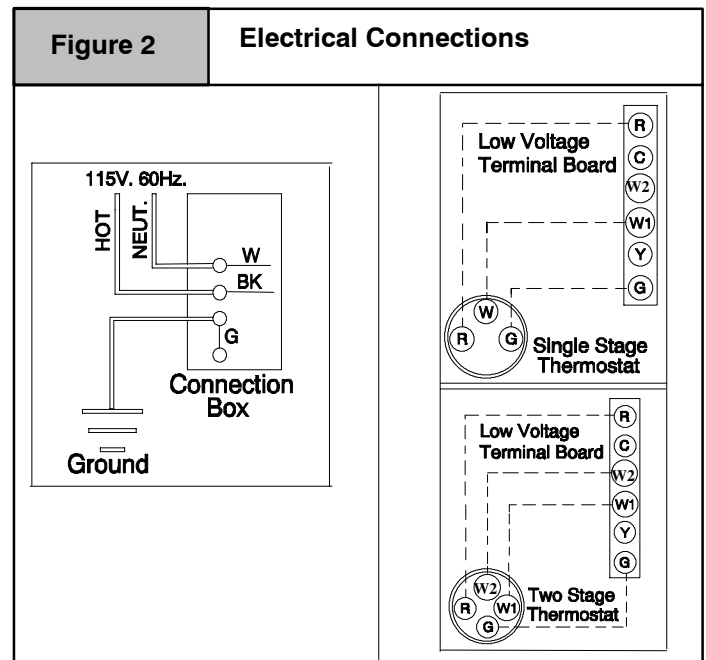

Polarity may be verified as follows:

1. Turn the power supply "ON".
2. Using a **Voltmeter** check for voltage between the **Hot** (Black) and **Neutral** (White) wire of supply circuit.
3. Reading should be **Line (Supply) Voltage**.
4. Check for Voltage between the **Neutral** (White) wire and **Ground** wire of the supply circuit.
5. Reading should be **zero Volts**. (if line voltage is read, polarity is reversed)
6. A zero Volt reading indicates there is no voltage potential on Neutral wire.
7. Double check by checking for voltage between the **Hot** (Black) wire and **Ground** wire of the supply circuit.
8. Reading should be **Line (supply) Voltage**. (if zero volts is read, there is no ground, or polarity is reversed.)

5. INTERLOCK SWITCH

The blower compartment door of all models is equipped with an interlock switch. This switch is "Normally Open" (closes when the door is on the furnace) and interrupts furnace operation when the door is open. This interlock switch is a safety device, and **SHOULD NEVER BE BY-PASSED**.

Since this is a single pole switch, (breaking only one side of the line) proper line voltage is essential to insure that furnace components are not "HOT" when switch is open. (See *Checking Grounding and Polarity*)

Figure 3 Typical Interlock Switch

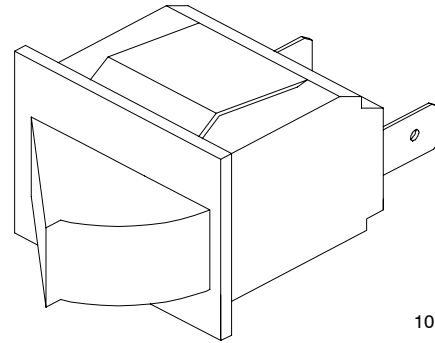

10-12-96

6. GAS SUPPLY

Figure 4 Typical Gas Valve Honeywell

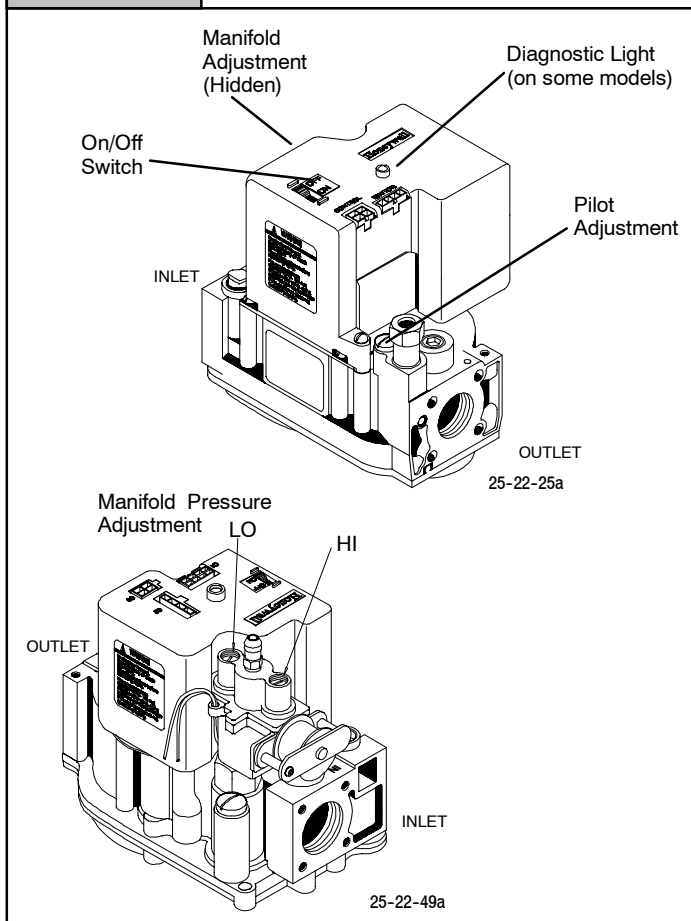

NATURAL GAS

Inlet (Supply) pressure to the furnace should be checked (at the gas valve) with **ALL OTHER GAS FIRED APPLIANCES OPERATING**. Inlet (Supply) pressure to the furnace under these conditions **MUST** be a minimum of 4.5" W.C. (Water Column). If the inlet pressure is less, it may be an indication of undersized piping or regulator problems.

L.P. GAS

Inlet (Supply) pressure to the furnace should be checked in the same manner as for Natural Gas, however with L.P. Gas, the inlet pressure **MUST** be a minimum of 11" W.C. If this cannot be obtained, problems are indicated in either the regulator or pipe sizing.

Table 1 Gas Pressures Below 2000'

Gas Type	Supply Pressure			Manifold Pressure	
	Recommended	Max.	Min.	Hi Fire	Lo Fire
Natural	7"	14"	4.5"	3.5"	1.7"
LP	11"	14"	11"	10"	4.9"

Important Note:

- With Propane gas, the rated input is obtained when the BTU content is 2,500 BTU per cubic foot and manifold pressure set at 10" W.C.
- If Propane gas has a different BTU content, orifices **MUST** be changed by licensed Propane installer.
- Measured input can **NOT** exceed rated input.
- Any major change in gas flow requires changing burner orifice size.

CHECKING INPUT (FIRING) RATE

Once it has been determined that the gas supply is correct to the furnace, it is necessary to check the input (firing) rate. This can be done in two (2) ways. First by checking and adjusting (as necessary) the manifold (Outlet) pressure. The second way is to "Clock" the gas meter.

An adequately sized gas supply to the furnace is required for proper operation. Gas piping which is undersized will not provide sufficient capacity for proper operation. Piping should be sized in accordance with accepted industry standards.

⚠ WARNING

Fire or explosion hazard.

Turn OFF gas at shut off before connecting manometer.

Failure to turn OFF gas at shut off before connecting manometer can result in death, personal injury and/or property damage.

CHECKING MANIFOLD PRESSURE

1. Connect manometer or Magnehelic gauge to the tapped opening on the outlet side of gas valve. Use a manometer with a 0 to 12" minimum water column range.
2. Turn gas ON. Operate the furnace on high fire by using a jumper wire on the R to W1 & W2 thermostat connections on the fan board.
3. Remove the adjustment cover on the gas valve. Turn adjusting screw counterclockwise to decrease the manifold pressure and clockwise to increase. See **Figure 4**.
4. Set the manifold pressure to value shown in **Table 1** or **Table 2**.
5. Operate the furnace on low fire by using a jumper wire on the R to W1 thermostat connections on the fan board.
Note: The fourth (4th) DIP switch should be in the on position to set the low fire manifold pressure. (See wiring diagram)
6. Repeat steps 4 and 5 for low fire operation.
7. When the manifold pressures are properly set, replace the adjustment screw covers on the gas valve.
8. Remove the jumper wires from the thermostat connections on the fan board. Remove manometer and replace plug in gas valve.
9. Return fourth (4th) DIP switch to previous setting.
10. Replace the burner compartment door.

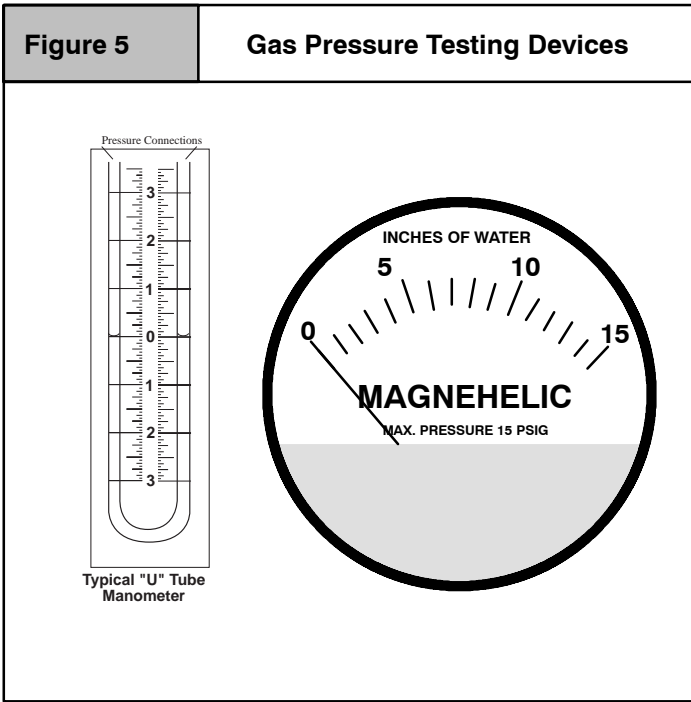

MANIFOLD PRESSURE AND ORIFICE SIZE FOR HIGH ALTITUDE APPLICATIONS

Heat Value Btu/Cu.Ft.	High Altitude Pressure Chart 2000-8000 ft. (Natural Gas)													
	Elevation Above Sea Level													
	0-1999		2000-2999		3000-3999		4000-4999		5000-5999		6000-6999		7000-7999	
	High	Low	High	Low	High	Low	High	Low	High	Low	High	Low	High	Low
800	3.5	1.7	3.5	1.7	3.5	1.7	3.5	1.7	3.5	1.7	3.5	1.7	3.5	1.7
850	3.5	1.7	3.5	1.7	3.5	1.7	3.5	1.7	3.5	1.7	3.5	1.7	3.5	1.7
900	3.5	1.7	3.5	1.7	3.5	1.7	3.5	1.7	3.5	1.7	3.5	1.7	3.4	1.7
950	3.5	1.7	3.5	1.7	3.5	1.7	3.5	1.7	3.3	1.6	3.2	1.6	3.1	1.5
1000	3.5	1.7	3.4	1.7	3.3	1.6	3.2	1.5	3.0	1.5	2.9	1.4	2.8	1.4
1050	3.2	1.6	3.1	1.5	3.0	1.5	2.9	1.4	2.7	1.3	2.6	1.3	2.5	1.2
1100	2.9	1.4	2.8	1.4	2.7	1.3	2.6	1.3	2.5	1.2	2.4	1.2	2.3	1.1
Orifice Size	#42		#42		#42		#42		#42		#42		#42	

“CLOCKING” GAS METER (NATURAL GAS)

1. Check with gas supplier to obtain ACTUAL BTU content of gas.
2. Turn “OFF” gas supply to ALL other gas appliances.
3. Operate furnace on HIGH fire, and time how many seconds it takes the smallest (normally 1 cfh) dial on the gas meter to make one complete revolution.
4. Calculate HIGH fire input rate by using ACTUAL BTU content of gas in formula shown in example.

5. Operate furnace on LOW fire, and time how many seconds it takes the smallest (normally 1 cfh) dial on the gas meter to make one complete revolution.
6. Calculate LOW fire input rate by using ACTUAL BTU content of gas in formula shown in example.

Example			
Natural Gas BTU Content	No. of Seconds Per Hour	Time Per Cubic Foot in Seconds	BTU Per Hour
1,000	3,600	48	75,000
1,000 x 3,600 ÷ 48 = 75,000 BTUH			

7. L.P. PRESSURE SWITCH

Models converted to operate on L.P. Gas will be installed with an L.P. Pressure Switch. The switch will be located in the gas supply line (in a "Tee" fitting), just ahead of the gas valve.

The purpose of this switch is to prevent furnace operating under low line (Supply) pressure conditions. Operating under low line pressure conditions, can create problems such as incomplete combustion, flashback, sooting, etc.

The switch is a "Normally Open" pressure operated switch that is wired in series with the furnace (Lo-fire) pressure switch. The L.P. Pressure Switch closes when line (Supply) pressure is 8.0" W.C. or higher. the L.P. Pressure Switch Opens if line pressure falls below 6.0" + 0.6" W.C. interrupting power to the gas valve.

It is located (electrically) between the Main Limit Switch and the furnace (vent) pressure switch. The switch is located (electrically) between the Furnace (Lo-fire) pressure switch and the gas Valve.

8. HIGH ALTITUDE OPERATION

These furnaces are designed to operate in the majority of the country without modifications. At altitudes over 2,000' above sea level, however, certain measures need to be taken to insure continued, safe reliable operation. For example, units must be de-rated for altitude (by adjusting manifold pressure and/or changing orifice size) based upon the type of fuel (I.E. Natural Gas or L.P. gas), Btu content of the gas, and installed altitude.

9. BURNERS

Burners used in this series of furnace are of the "INSHOT" type. Their operation can be compared to that of a torch in that they produce a hard, sharp, somewhat noisy flame. Noise should not be an issue, however, because of the closed burner box design. In order to insure that the burners are operating properly, and at their design noise level, proper adjustment of the gas (manifold) pressure is essential. For further information on manifold pressure adjustments check the section on "Gas Supply".

The burners used in this series ARE NOT EQUIPPED WITH AIR SHUTTERS, as none are required. Proper operation (flame characteristics) is obtained by insuring that the orifice size, and manifold pressure are correct for the fuel being used and the altitude of the installation.

Figure 6

Typical L.P. Pressure Switch

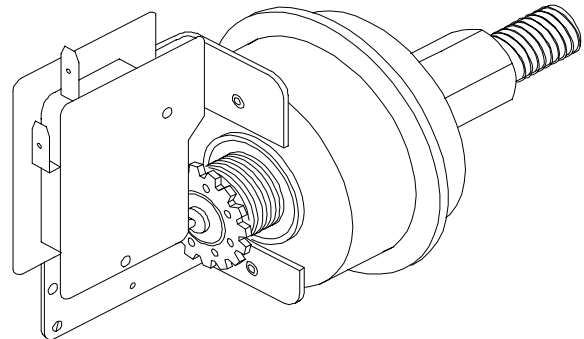

ALL UNITS must have a high altitude pressure switch installed at altitudes above 4,000' above sea level.

When servicing a unit installed at altitudes above 2,000' insure that it has been properly modified to operate at that altitude. See the sections on Gas pressure, and pressure switches to obtain specific information for you particular installation altitude.

Figure 7

Main Burner

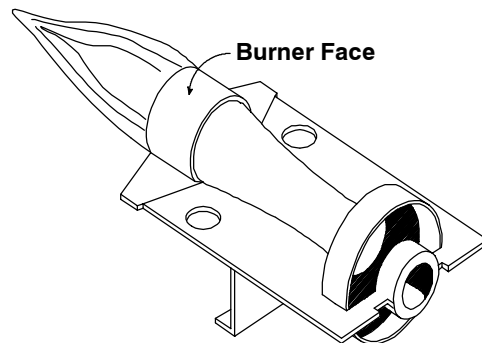

10-10-78

10. CHECKING TEMPERATURE RISE

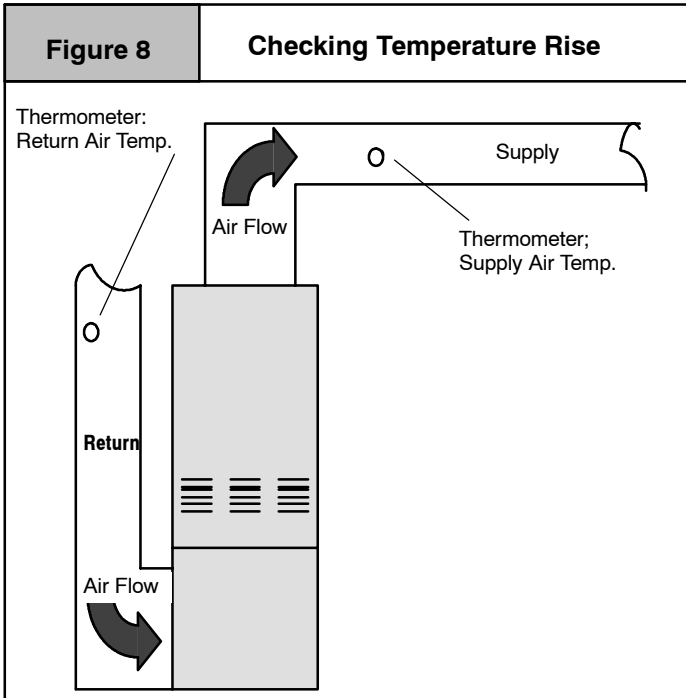

The furnace is designed to operate within a certain specified range of temperature rise.

Operating the furnace outside the specified range may result in lower efficiency and/or comfort levels, as well as pre-mature combustion component failures.

Simply stated, the temperature rise through the furnace is the difference in temperature between the return air, and the supply air.

NOTE: BEFORE CHECKING TEMPERATURE RISE BE CERTAIN THAT MANIFOLD PRESSURE IS PROPERLY ADJUSTED.

ALLOWABLE TEMPERATURE RISE FOR

11. ROOM THERMOSTATS

Room thermostats are available from several different manufactures in a wide variety of styles. They range from the very simple and inexpensive Bi-metallic type to the complex. They are simply a switch (or series of switches) designed to turn equipment (or components) "ON" or "OFF" at the desired conditions.

2-STAGE MODELS

Model	Fire	Range
50 Mbtu	HI	35°F - 65°F
	LOW	25°F - 55°F
75 Mbtu, 100 Mbtu & 125 Mbtu	HI	40°F - 70°F
	LOW	30°F - 60°F

Always check current "Technical Support Manual"

ALLOWABLE TEMPERATURE RISE FOR VARIABLE SPEED MODELS

Model	Fire	Range
50 Mbtu	HI	35°F - 65°F
	LOW	35°F - 65°F
75 Mbtu, 100 Mbtu & 125 Mbtu	HI	40°F - 70°F
	LOW	40°F - 70°F

Always check current "Technical Support Manual"

Operate the furnace for 15 minutes before taking temperature readings. Subtract the return air temperature from the supply air temperature. The result is the temperature rise. Compare with the allowable rise listed for the model (size) you are checking.

Temperature Rise can be checked by placing a thermometer in the return air duct within 6' of furnace. Place a second thermometer in the supply duct at least two (2) ft. away from the furnace. (This will prevent any false readings caused by radiation from the furnace heat exchanger) Make sure that the FILTER IS CLEAN and that ALL REGISTERS AND/OR DAMPERS ARE OPEN.

If the rise is not within the specified range, it will be necessary to change the heating blower speed. **If the rise is too high**, it will be necessary to **increase the blower speed**. **If the rise is too low**, it will be necessary to **reduce the blower speed**.

Example:

Supply Temp. 170°
 Return Temp. 70°
 Temperature Rise 100° = Too High

Solution: Increase Blower Speed

An improperly operating, or poorly located room thermostat can be the source of perceived equipment problems. A careful check of the thermostat and wiring must be made then to insure that it is not the source of problems.

Figure 9

Thermostat Location

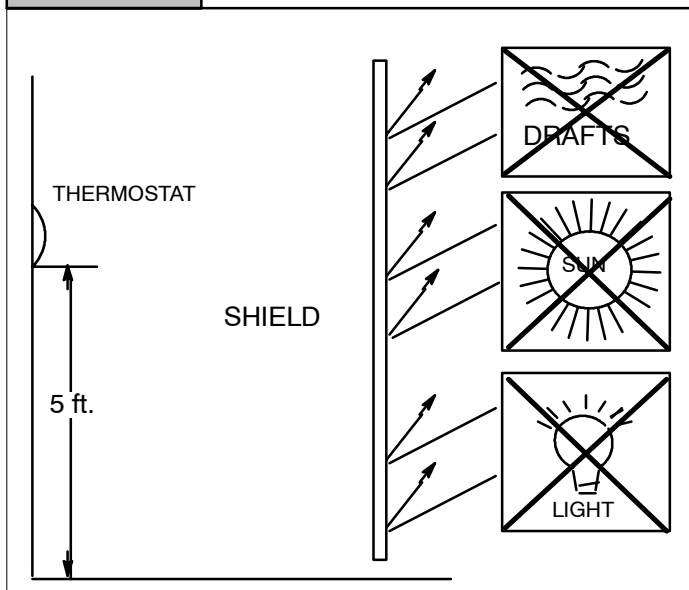

LOCATION

The thermostat should not be mounted where it may be affected by drafts, discharge air from registers (hot or cold), or heat radiated from the sun of appliances. Never install in alcoves, bathrooms or bedrooms.

The thermostat should be located about 5 ft. above the floor in an area of average temperature, with good air circulation. Normally, an area in close proximity to the return air grille is the best choice.

Mercury bulb type thermostats **MUST** be level to control temperature accurately to the desired set-point. Electronic digital type thermostats **SHOULD** be level for aesthetics.

HEAT ANTICIPATORS

Heat anticipators are small resistance heaters built into most electric-mechanical thermostats. Their purpose is to prevent wide swings in room temperature during furnace operation.

In order to accomplish this, the heat output from the anticipator must be the same regardless of the current flowing through it. Consequently, most thermostats have an adjustment to compensate for varying current draw in the thermostat circuit.

The proper setting of heat anticipators then is important to insure proper temperature control and customer satisfaction.

The best method to obtain the required setting for the heat anticipator, is to measure the actual current draw in the con-

trol circuit ("W") using a low range (0-2.0 Amps) Ammeter. (See **Figure 10**) After measuring the current draw, simply set the heat anticipator to match that value.

Figure 10

Measuring Current Draw

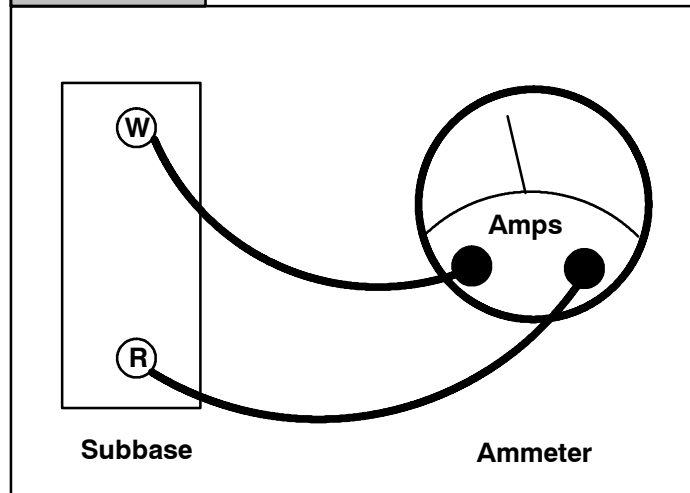

If a low range ammeter is not available, a "Clamp-on" type meter may be used as follows:

1. Wrap EXACTLY ten (10) turns of wire around the jaws of a clamp-on type ammeter.
2. Connect one end of the wire to the "W" terminal of the thermostat sub-base, and the other to the "R" terminal.
3. Turn power on, and wait approximately 1 minute, then read meter.
4. Divide meter reading by 10 to obtain correct anticipator setting.

NOTE: For 2 Stage heating thermostats the above procedure **MUST** be performed twice. Once for first stage (W1), and once for second stage (W2), if both stages have adjustable heat anticipators.

If an ammeter is not available, a setting of 0.10 amps may be used for models equipped with the HONEYWELL SV9541Q Gas Valve/Ignition Control. They should, however, provide satisfactory operation in most cases.

Electronic thermostats do not use a resistance type anticipator. These thermostats use a microprocessor (computer) that determines a cycle rate based on a program loaded into it at the factory.

These cycle rates are normally field adjustable for different types to equipment. The method of adjustment, however, varies from one thermostat manufacturer to another. Check with the thermostat manufacturer to find out the proper way of adjusting the cycle rate.

12. CONTROL WIRING

Control wiring is an important part of the total equipment installation, since it provides the vital communications link between the thermostat, and the equipment. It is often overlooked as the source of equipment malfunctions. Control wiring that is either too long, undersized, or improperly connected (be it simply loose, or on the wrong terminal) can in fact be the source of many equipment problems.

ALWAYS check to make sure that the control wiring is connected to the proper terminal(s) of the equipment and thermostat you are using. Remember, also, that thermostat terminals are not always identified alike by different thermostat manufacturers. Connections **MUST** be clean and tight to insure trouble-free operation.

The controls of this series of 2-Stage furnaces are designed to provide 2-Stage operation using a Two (2) Stage Thermostat, **ONLY** as follows:

The 2-stage furnace control will operate with either a single stage or a two stage heating thermostat and will provide 2-stage heating operation. For single stage thermostat installations, the **R** and **W** wires from the thermostat connect to the **R** and **W1** connections on the furnace control. **Note:** The fourth (4th) DIP switch must be in the off position, failure to change DIP switch will result in Lo Fire **ONLY** operation. (See furnace wiring digram) See "*Furnace Wiring Diagram*" for switch settings. Failure to set DIP switch will result in Lo fire operation **ONLY** with single stage thermostat. During operation, the furnace will operate on low fire for 12 minutes if the heat request exists for more than 12 minutes. If the heat request exists for more that 12 minutes, the furnace will automatically shift to the high fire mode for the remaining duration of the heating cycle. For two stage thermostat installations, the **R**, **W1** and **W2** wires from the thermostat connect to the **R**, **W1** and **W2** connections on the furnace control. During

13. LIMIT SWITCHES

Two (2) different kinds of limit switches are used on this series of furnaces. They are the main limit and roll out limit switches. The main limit, and roll out limit switches are used on all models.

NOTE: All limit switches are safety devices and other than for testing purposes, **should never be jumped out!** Limit switches are "normally closed" electrical switches, designed to open when their predetermined "limit setting" has been reached.

It should also be remembered, that when a limit switch opens, it more than likely is not due to a bad switch! The cause of the opening limit must be found and corrected, be-

fore the furnace can resume proper operation.

operation, the furnace will shift from low fire to high fire as requested by the thermostat. The thermostat heat anticipators should be adjusted to a .10 setting for both types of thermostats.

Low voltage connections to furnace must be made on terminal board to fan control.

The **ELECTRONIC CONTROLS** used on this series **RESPOND DIFFERENTLY** to certain control wiring practices which have been generally accepted in the HVAC industry for many years.

For Example: For years, installers have run a wire from the "Y" terminal of the room thermostat and connected it directly to the contactor coil of a condensing unit. (not making any connection to the furnace with this wire) Then, run the low voltage "Common" wire from the condensing unit back to the "C" terminal of the furnace.

With the **HONEYWELL ST9162A** electronic Fan Timer/Furnace Control used in the models of this series, however, the "Y" terminal of the furnace does in fact serve a particular purpose. Failure to connect it will result in certain improper operation as follows:

The **COOLING** fan speed is energized via the "Y" terminal. **Failure to connect** the thermostat "Y" terminal to the "Y" terminal on the control will result in the **failure to energize the COOLING speed** on a call for cooling from the thermostat. (Depending upon the model, either the **LOW HEATING** speed or the **CIRCULATING** speed will be energized instead via the "G" terminal)

For more detailed information about this control, see the section on the ST9162A control beginning on page 23 of this manual.

fore the furnace can resume proper operation.

⚠ WARNING

Fire hazard.

Limit controls are factory preset and MUST NOT be adjusted. Use ONLY manufacturer's authorized replacement parts.

Failure to do so can result in death, personal injury and/or property damage.

The specific functions of the two (2) limit switches used in this series of furnaces are as follows:

MAIN LIMIT SWITCH

A “Normally Closed” switch located on the front partition of the furnace. It monitors supply air temperature, and interrupts furnace (burner) operation when a supply air temperature is sensed which would result in the furnace exceeding Maximum allowable outlet air temperature. While the main limit is open, combustion blower, and/or the circulating blower will be energized continuously. This control is an “Automatic” reset control, which will reset itself when the temperature sensed drops to a safe level.

If furnace (burner) cycles on this limit switch, (I.E. switch opens and closes during furnace operation) it is more than likely due to a high temperature rise through the furnace. (See checking temperature on page 8 of this manual)

High temperature rise can be caused by either OVER FIRING (high manifold pressure, incorrect orifices, etc.) or LOW AIR FLOW (dirty filter, blower speed too low, excessive static in duct system, etc.)

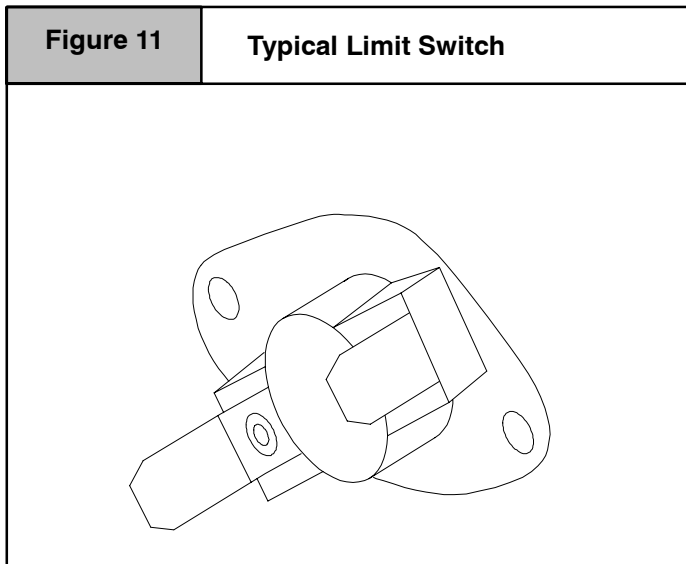

To verify this, the cut-out (opening) point of the switch should be checked (using a thermocouple type thermometer connected to the face of the switch) as follows:

1. Operate furnace for several minutes.
2. Block return air grille(s) to furnace.
3. Observe temperature at which switch opens (burner operation ceases).
4. Remove blockage from return grille(s).
5. Observe temperature at which switch closes (burner operation resumes).
6. Compare readings with the limit setting listed in the appropriate chart for the model you are servicing.

If switch is opening within the specified range, then it is simply doing its job, and the cause of the over-temperature must be determined and corrected.

If, however, the switch is found to be opening prematurely, then it should be replaced. When replacing ANY limit switch, use ONLY a switch of EXACTLY the same temperature setting. Use of a different temperature limit switch can create a dangerous situation. Some of the main limit switches used in this series are SIMILAR IN APPEARANCE. DIFFERENT TEMPERATURE SETTINGS, HOWEVER, ARE USED for different models. Be certain you have the correct control for the model you are servicing.

ROLL OUT LIMITS

Those “Normally Closed” unit switches (wired in series with the Main Limit switch) on the top are mounted on the bottom (left & right) of the burner box.

The switches are manual reset type. When replacing this switch, be absolutely certain the correct one is used.

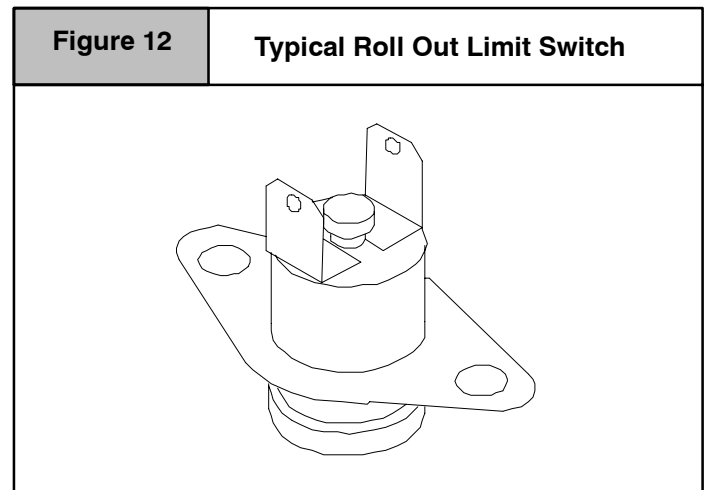

CAUTION

NEVER use an automatic reset roll out switch to replace a manual reset type roll out switch.

Doing so may cause potentially unsafe and/or intermittent operation.

The roll out switch monitors the temperature inside the burner box, and interrupts furnace (burner) operation when its temperature indicates flame roll out has occurred.

If the roll out switch has opened, the cause must be determined. Some possible reasons for flame roll out include a restricted primary or secondary heat exchanger or over fired furnace.

MANUAL RESET SWITCH MODELS

Furnace models which are equipped with a Honeywell ST9162A Fan timer/furnace control use a manual reset roll out switch. Once the roll out switch has opened, burner operation will be prevented until the roll out switch is “Manually Reset” by pressing the red button located on the switch. While the roll out switch is open, (Depending upon the particular model) the combustion blower and/or circulating blower will be energized continuously.

14. PRESSURE SWITCHES

TRANSITION PRESSURE SWITCH

Under normal operating conditions, sufficient pressure is developed by the exhaust (combustion) blower to close the switch, and permit the burner to operate. As the condensate drain begins to back-up, however, the pressure begins to reduce. When the pressure drops sufficiently, burner operation will be prevented until the condition is corrected.

STANDARD PRESSURE SWITCHES - ALL MODELS

Model	Max. Close	Open	Part #
Condensing 50, 75 &100	-1.70" W.C.	-1.50 ± 0.10" W.C.	
125	-2.00" W.C.	-1.80 ± 0.10" W.C.	

Always check current "Technical Support Manual" for Part Nos.

BLOWER PRESSURE SWITCH

An air proving switch (pressure switch) is used on all models to insure that a draft has been established through the heat exchanger before allowing burner operation.

To insure continued SAFE, RELIABLE, operation, NEVER SUBSTITUTE a pressure switch with one that is similar in appearance. ONLY FACTORY PROVIDED or AUTHORIZED SUBSTITUTES ARE ACCEPTABLE.

All models installed at altitudes of 4,000' above sea level or higher require replacing the standard pressure switch with a high altitude pressure switch. The different pressure switch settings allow continued SAFE, RELIABLE, high altitude operation.

Note: Transition switch checks lo-fire airflows & blocked condensate. Blower switch checks Hi-fire airflow.

HIGH ALTITUDE PRESSURE SWITCHES - ALL MODELS

Model	Max. Close	Open	Part #
Condensing 50, 75 &100	-1.40" W.C.	-1.20 ± 0.10" W.C.	1013165
125	-1.70" W.C.	-1.50 ± 0.10" W.C.	1013157

Always check current "Technical Support Manual" for Part Nos.

Under normal operating conditions, sufficient negative pressure will be created to close the pressure switch, and keep it closed to keep furnace operating. Under abnormal conditions, however, such as a restricted vent pipe, or a leak in one of the heat exchangers, sufficient negative pressure will not be created. This will result in the switch failing to close or failing to remain closed during furnace operation.

Figure 13 Pressure Switches

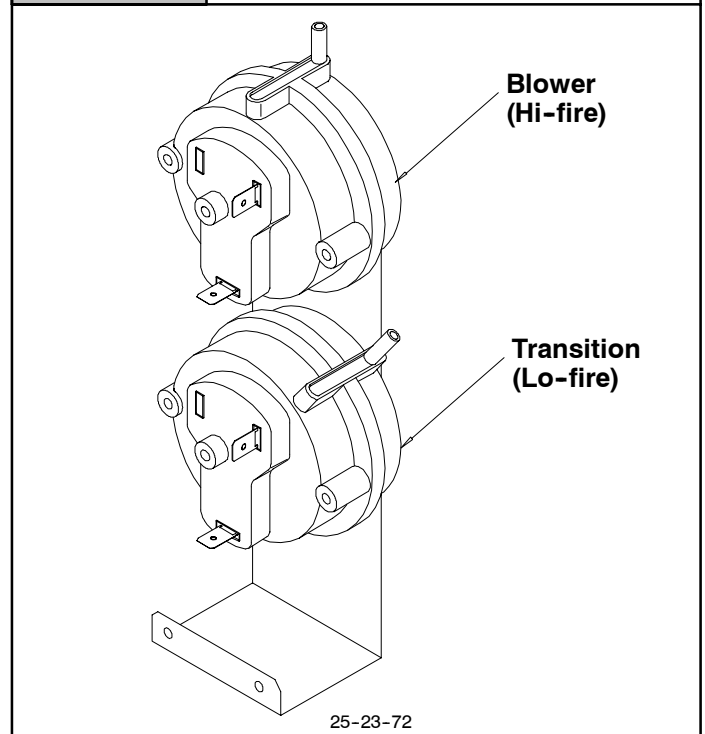

When servicing a unit whose pressure switch will not close, or remain closed during operation, the operating pressure of that furnace should be checked and compared to approximate operating pressures listed in **Table 3** and the switch setting(s) listed above for the model family you are servicing.

It is important to remember, that greater negative pressures are created by the furnace when "Hot" (I.E. upon initial start-up) than when "Cold" (I.E. after furnaces has been in operation for a few minutes). Because of this, furnace pressure should ONLY be checked when "HOT" to insure accurate readings.

Table 3 lists approximate operating pressures for Direct Vent (I.E. Two Pipe) installations of models in this series. They were obtained in a test lab, under controlled conditions using two (2) specific vent lengths. They are included in this manual to provide you with a "Barometer" to gauge our pressures against. The pressures you obtain in the field will differ slightly from these figures based upon vent length, gas pressure, operating temperature, etc.

Major discrepancies in pressures, will normally cause problems with pressure switch operation. These Major discrepancies should be investigated as follows:

Table 3	APPROXIMATE OPERATING PRESSURES (INCHES OF W.C.)			
	Model	Vent Length	@Blower/@Transition	
			(High Fire)	(Low Fire)
50 Mbtu & 75 Mbtu	Short - (5 Ft. No Elbows)	-1.80/-2.60	-1.20/-1.90	
	Long - (40 Ft. + 5 90° Elbows)	-1.30/-2.30	-1.00/-1.80	
100 Mbtu	Short - (5 Ft. No Elbows)	-1.80/-2.60	-1.20/-1.90	
	Long - (40 Ft. + 5 90° Elbows)	-1.70/-2.50	-1.00/-1.80	
125 Mbtu	Short - (5 Ft. No Elbows)	-1.80/-2.60	-1.30/-2.30	
	Long - (40 Ft. + 5 90° Elbows)	-1.70/2.50	-1.20/-2.20	

Always check current "Technical Support Manual" for updated information.

2. Leak (lack of restriction) on the **Inlet** side of the combustion blower.

Lower (Lesser) Negative Pressures

Lower than normal negative pressures measured at the **Combustion Blower** may be caused by:

1. Restriction on the **Outlet** side of the combustion blower. (I.E. Blocked Flue, Vent too long, Heat Exchanger leak, etc.)

Higher (Greater) Negative Pressures

Higher than normal negative pressures measured at the **Combustion Blower** may be caused by:

1. Restriction on the **Inlet** side of the combustion blower. (I.E. Plugged Heat Exchanger, air inlet orifice too small)

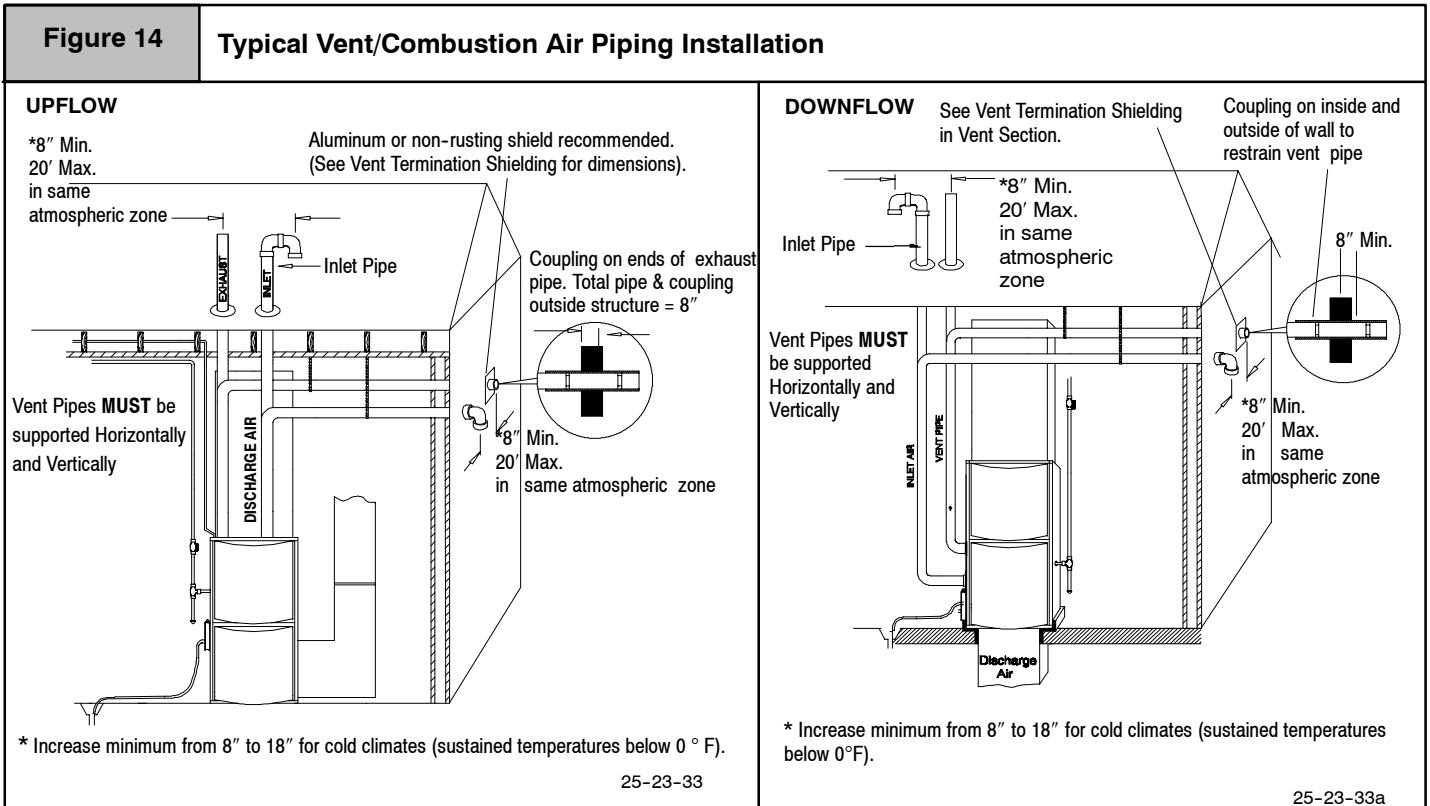

15. VENT/COMBUSTION AIR PIPING

Vent and combustion air piping are an extremely important part of the total furnace installation. Improperly installed or inadequately sized vent and/or combustion air piping can be the source of many perceived furnace problems.

For example, most problems associated with pressure switch operation can normally be traced to short comings in the vent and/or combustion air piping. Anytime these type

problems arise, a thorough inspection of the vent and/or combustion air piping should be conducted.

ALL MODELS require a vent (exhaust) pipe to carry flue products to the outside of the structure.

Direct VENT (ONLY) models require a combustion air inlet to bring in **all air for combustion from outside** the structure.

DUAL CERTIFIED models require a combustion air inlet pipe to bring in all air for combustion from outside the structure **only** when installed as a Direct Vent Furnace (I.E. Two Pipe Installation)

Consult the appropriate Venting tables and/or piping chart for the model (series) you are servicing.

16. STANDARD VENT TERMINATION

Vent/Combustion Air Piping Charts

Single Piping Chart

Table 4	Pipe Diameter Table Single Piping ONLY
50,000 & 75,000 Btuh Furnaces	
40' & (5) 90° elbows with 2" PVC pipe	
100,000 & 125,000 Btuh Furnace	
40' & (5) 90° elbows with 3" PVC pipe	
Elbows are DWV Long Radius Type for 2" and 3" vents.	

If more than five elbows are required, reduce the length of both the inlet and exhaust pipes 5' for each additional elbow used.

NOTE: It is allowable to use larger diameter pipe and fitting than shown in the tables but **not** smaller diameters than shown.

Dual Piping Chart

Table 5	Pipe Diameter Table Dual Piping ONLY
50,000 & 75,000 Btuh Furnaces	
40' & (5) 90° elbows with 2" PVC pipe	
100,000 & 125,000 Btuh Furnace	
40' & (5) 90° elbows with 3" PVC pipe	
Elbows are DWV Long Radius Type for 2" and 3" vents.	

If more than five elbows are required, reduce the length of both the inlet and exhaust pipes 5' (1.5m) for each additional elbow used.

*Feet of pipe is whichever pipe run is the longest, either inlet or outlet side.

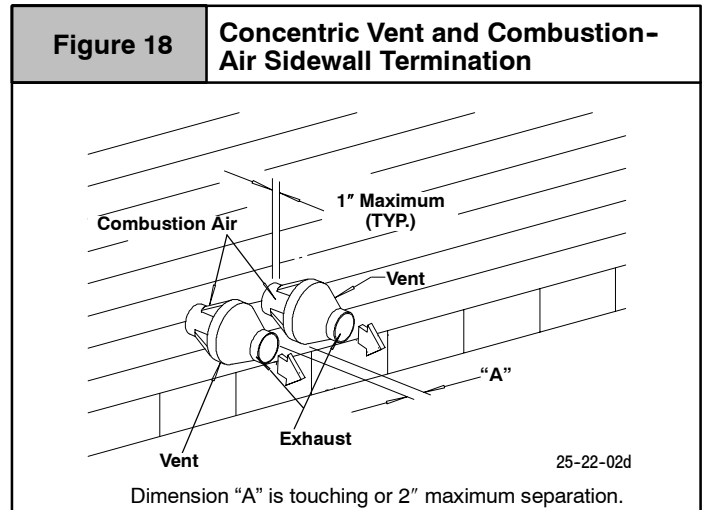
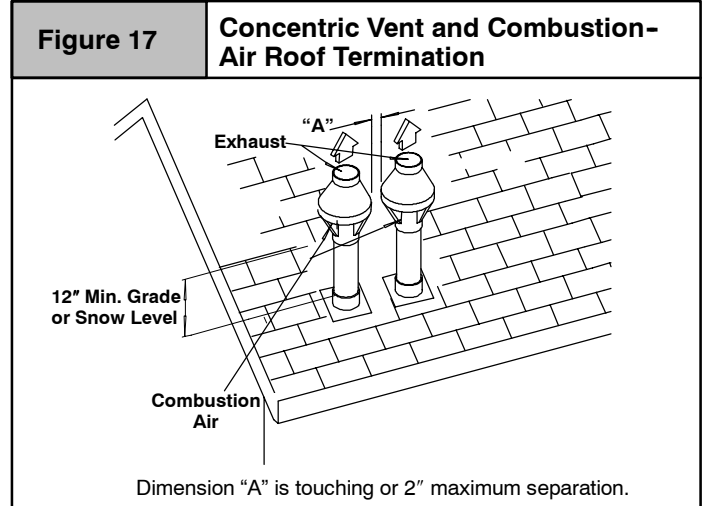
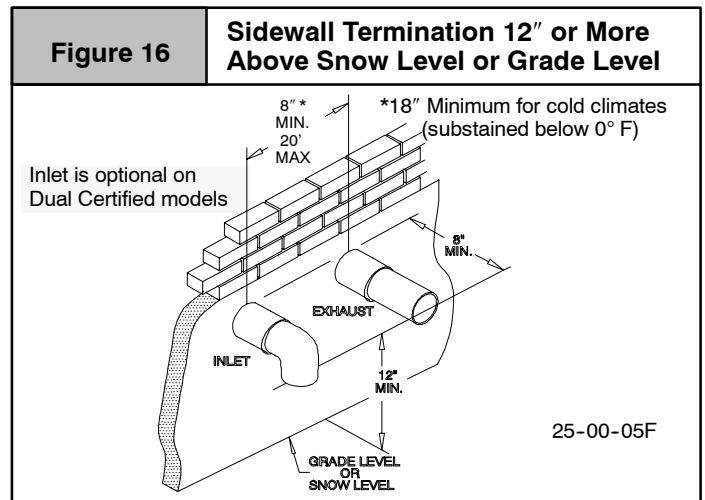
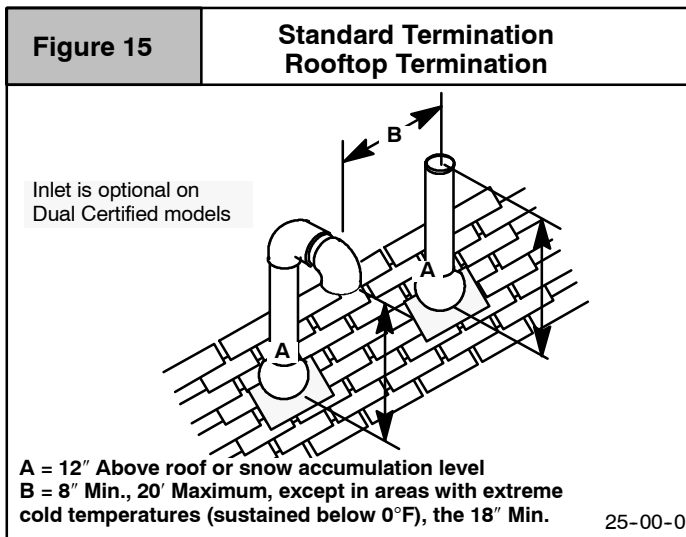

Figure 19

Sidewall Inlet Vent and Exhaust-Air Termination

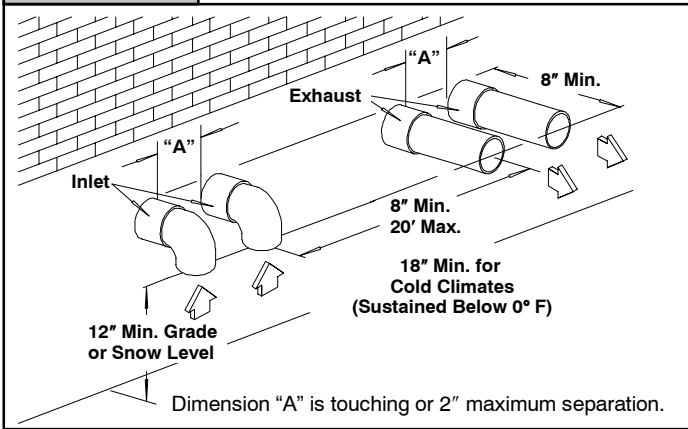

Figure 20

Sidewall Inlet Vent and Exhaust-Air Termination with Exterior Risers

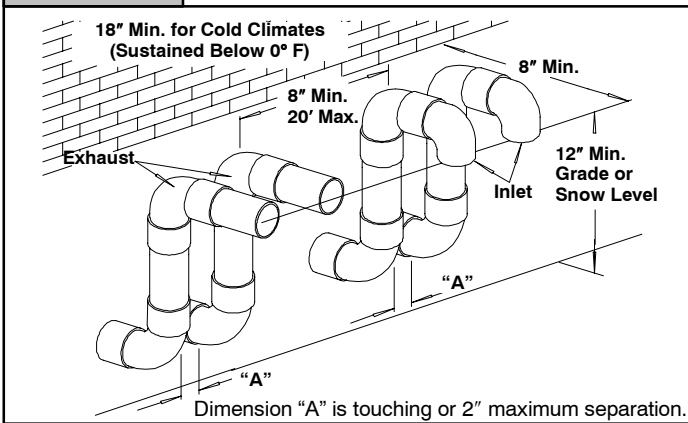

Figure 21

Rooftop Inlet Vent and Exhaust-Air Termination

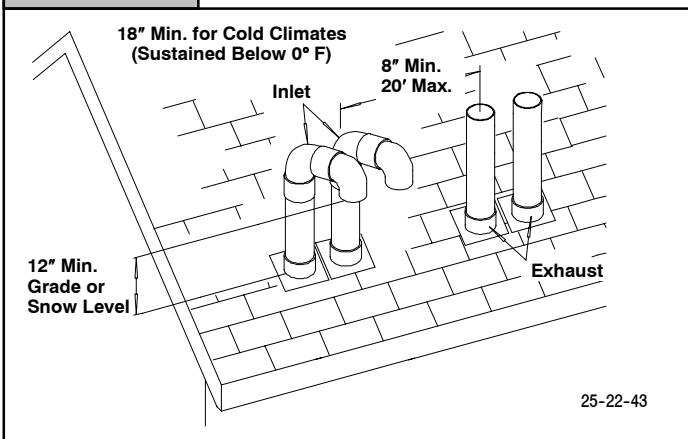
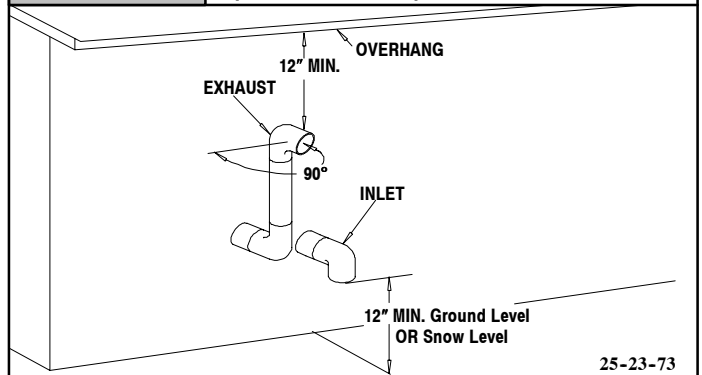

Figure 22

Recommended Alternate Installation for Sustained Cold Weather (-0° F & below)



FRONT VIEW

SIDE VIEW

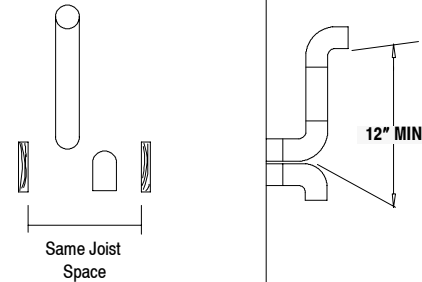

17. CONCENTRIC VENT TERMINATION

Vent/Combustion Air Piping Charts

Table 6	Concentric Termination Kit NAHA001CV & NAHA002VC Venting Table Dual Piping ONLY
50,000 & 75,000 Btuh Furnaces	
NAHA002CV - 35' & (4) 90° elbows with 2" PVC pipe	
100,000 & 125,000 Btuh Furnace	
NAHA001CV - 35' & (4) 90° elbows with 3" PVC pipe	
<ol style="list-style-type: none"> 1. Do not include the field supplied 45° elbow in the total elbow count. 2. If more than four elbows are required, reduce the length of both the inlet and the exhaust pipes five feet for each additional elbow used. 3. Elbows are DWV long radius type for 2" and 3" vents. 	

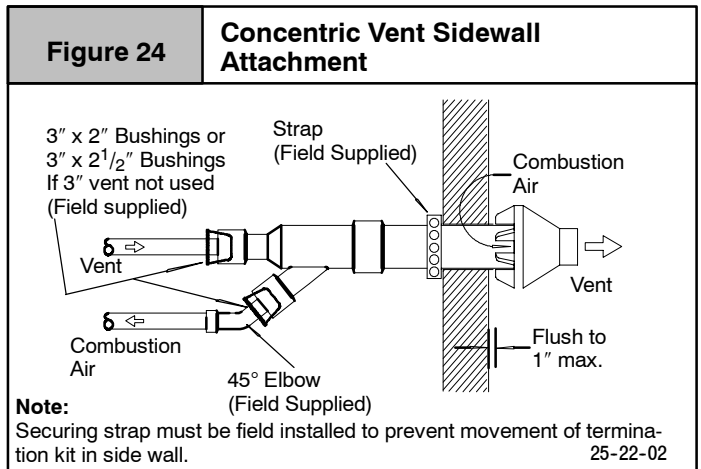
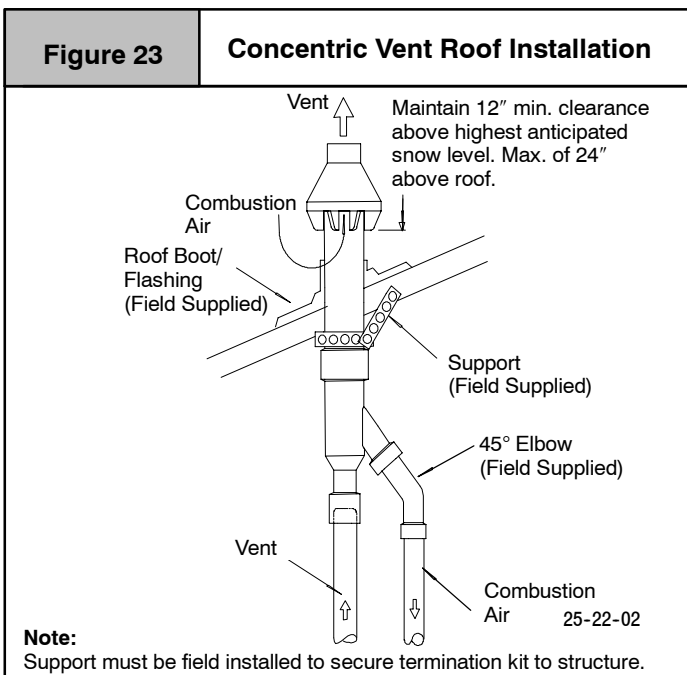

18. EXHAUST BLOWER

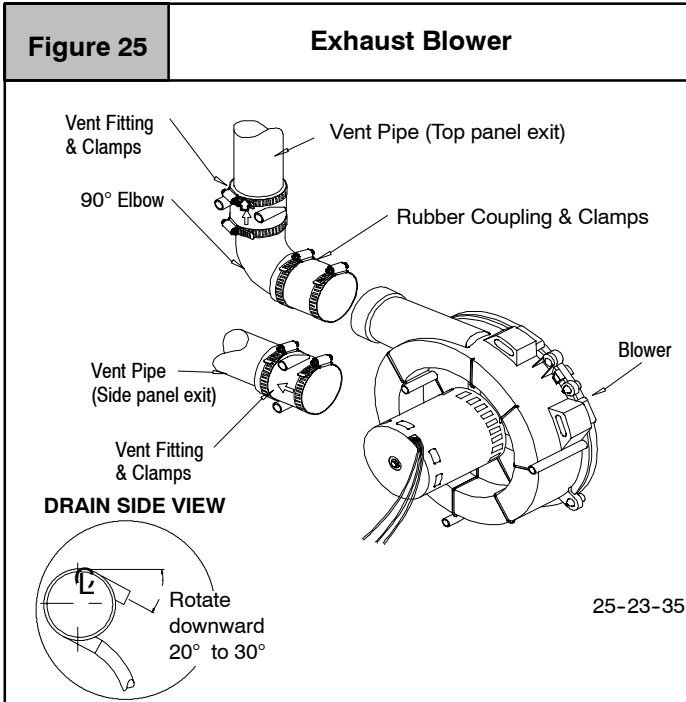

Always check the current "Technical Support Manual" for part nos.

19. CONDENSATE DRAIN TRAP

This furnace removes both sensible and latent heat from the products of combustion. Removal of the latent heat results in condensation of the water vapor. The condensate is removed from the furnace through the drains in the plastic transition and the vent fitting. The drains connect to the externally mounted condensate drain trap on the left or right side of the furnace. Refer to **Figure 26**.

The condensate drain trap supplied with the furnace **MUST** be used. The drain line between the condensate drain trap and the drain location must be constructed of $\frac{3}{4}$ " PVC or CPVC pipe.

The drain line must maintain a $\frac{1}{4}$ " per foot downward slope toward the drain.

DO NOT trap the drain line in any other location than at the condensate drain trap supplied with the furnace.

If possible **DO NOT** route the drain line where it may freeze. The drain line must terminate at an inside drain to prevent freezing of the condensate and possible property damage.

1. A condensate sump pump **MUST** be used if required by local codes, or if no indoor floor drain is available. The condensate pump must be approved for use with acidic condensate.
2. A plugged condensate drain line or a failed condensate pump will allow condensate to spill. If the furnace is installed where a condensate spill could cause damage, it is recommended that an auxiliary safety switch be installed to prevent operation of the equipment in the event of pump failure or plugged drain line. If used, an auxiliary safety switch should be installed in the R circuit (low voltage) **ONLY**.

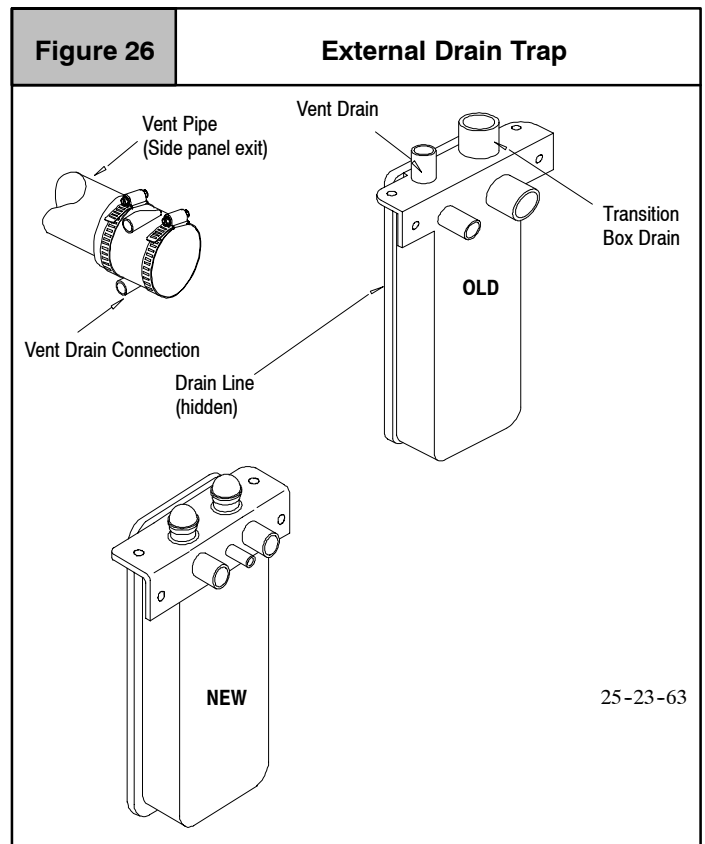

20. HONEYWELL ST9162A Series FAN TIMER/FURNACE CONTROL

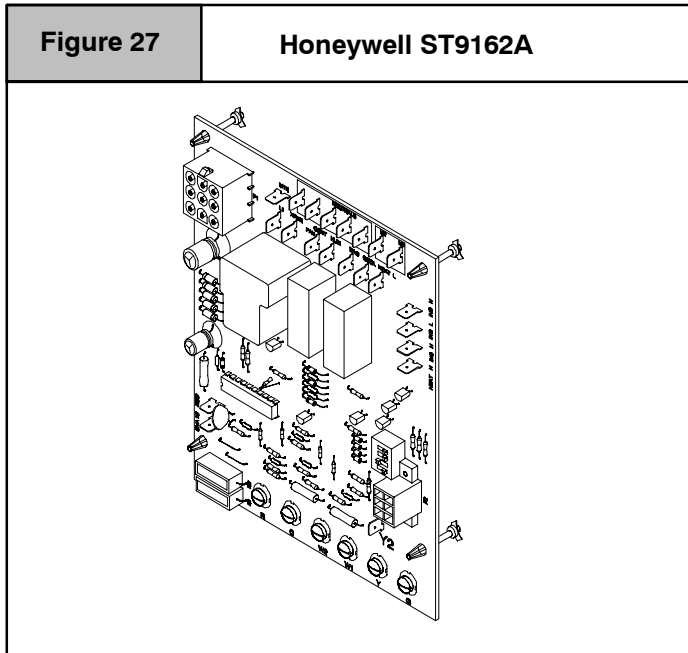

The HONEYWELL ST9162A Electronic Fan Timer/Furnace Control is an integrated electronic control, which contains NO USER SERVICEABLE COMPONENTS. In addition to controlling the fan operation for heating, it also takes the place of the blower relay, combustion air relay and/or system relay.

The ST9162A is used in conjunction with the SV9541Q GAS VALVE/IGNITION CONTROL. It provides the power source to begin the ignition sequence through a monitored safety circuit. It serves as a low voltage terminal strip, and provides accessory terminals for a Humidifier, Electronic Air cleaner and a "Continuous" terminal which can be used on models equipped with a Permeate Split Capacitor (P.S.C.) motor (ONLY) to provide continuous fan operation at a speed other than either the heating or cooling speed.

The control provides a fixed (non-adjustable) 5 second "ON" and 60 second "OFF" delay for the circulating blower in COOLING and an adjustable 30 or 60 second "ON" delay for the circulating blower in HEATING.

The ST9162A control also provides an adjustable HEATING "OFF" delay for the circulating blower which can be field adjusted to 60, 100, 140, or 180 seconds.

Setting "OFF" and "ON" delays

Setting The ST9162A Heating Fan "ON" & "OFF" Delay is accomplished by the positioning of "DIP" switches. The illustrations Figure 28, & Figure 29, indicate how to position these switches to obtain the desired setting.

The ST9162A Heating Fan "OFF" delay can be set to either 60, 100, 140, or 180 seconds. The control was shipped out in the 140 second position. This may be satisfactory for some installations, but not for others.

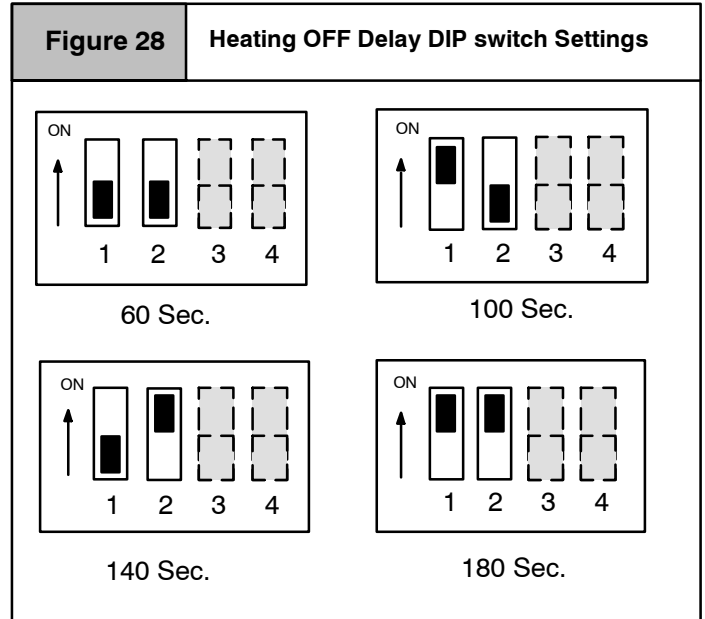

The ST9162A Heating Fan "ON" delay may be set to either 30 or 60 seconds. The control is shipped out at 30 seconds. As with the "OFF" delay, this may be satisfactory for some installations, but not for others.

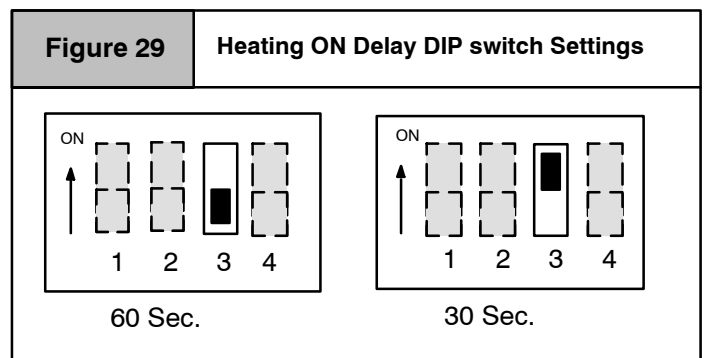

The "OFF" delay should be set as long as possible without creating "COLD AIR" complaints at the end of the cycle.

The "ON" delay should be set as short as possible without creating "COLD AIR" complaints at the beginning of the cycle.

The COOLING "ON" and "OFF" delays of the ST9162A are fixed at 5 seconds and 60 seconds respectively, and are not adjustable.

21. ST9162A/SV9541Q TESTING SEQUENCE

If furnace successfully passes this testing sequence, it can be assumed that there are no problems with the ST9162A/SV9541Q CONTROL SYSTEM. If it does not, however, it does not necessarily mean that there are problems with the control SYSTEM. Any malfunctions should be thoroughly investigated before replacing any components.

CHECKING HEATING FUNCTIONS

1. JUMPER "W1, or W1 & W2" TO "R"
2. CHECK COMBUSTION BLOWER START-UP
3. CHECK IGNITION SYSTEM ACTIVATION
4. WHEN MAIN BURNER LIGHTS, CHECK HEATING FAN "ON" DELAY
5. CHECK HEATING SPEED FAN OPERATION
6. REMOVE JUMPER
7. CHECK POST PURGE DELAY
8. CHECK HEATING FAN "OFF" DELAY

CHECKING COOLING FUNCTIONS

1. JUMPER "Y" & "G" TO "R"
2. CHECK COOLING FAN DELAY "ON"
3. CHECK COOLING SPEED FAN OPERATION
4. REMOVE JUMPER
5. CHECK COOLING FAN "OFF" DELAY

22. HONEYWELL SV9541Q 2-STAGE GAS VALVE/IGNITION CONTROL

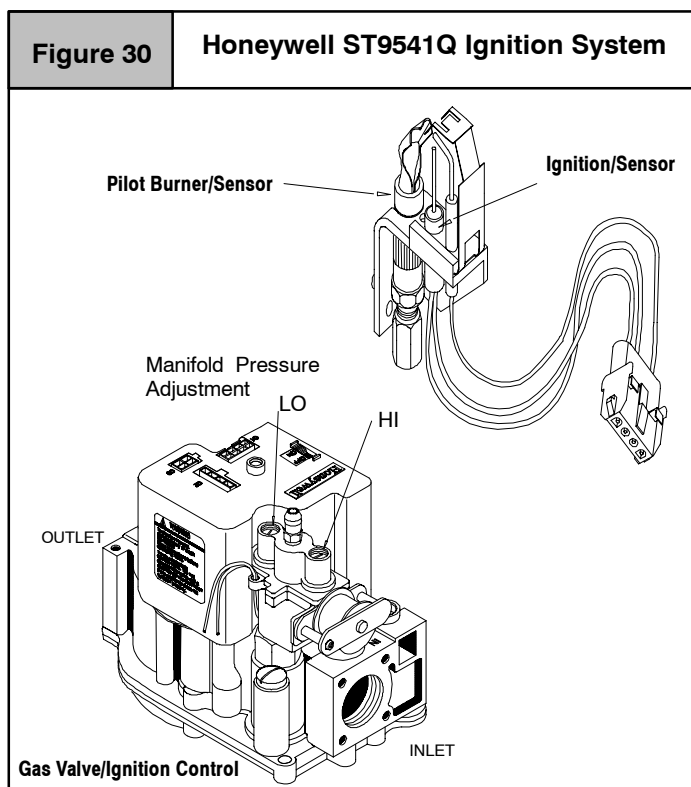

The system consists basically of only two (2) components. The Ignition System Control and the Pilot Hardware. They operate on Two (2) power circuits received from the ST9162A Fan Timer/Furnace Control. One is the 24 volt power supply for the ignitor, and to activate the ignition se-

quence. The second is a 115 volt circuit used to power the combustion blower.

The SV9541Q system **is not polarity sensitive**.

The SV9541Q Ignition System Control (working in conjunction with the ST9162A fan timer) manages the Ignition Sequence, and the flow of gas to the pilot and main burners. It is in essence a combination Gas Valve and Ignition control.

It contains sophisticated electronic components (internally) and has **NO USER SERVICEABLE COMPONENTS**. Should a problem be verified internally within the device, **IT IS NOT FIELD REPAIRABLE**, and must be replaced.

The Pilot Hardware includes the pilot burner, the hot surface element that lights the pilot burner, the flame rod that senses pilot flame, and the cable that attaches to the system control.

The hot surface element is made of a tough *break resistant* ceramic composite material. It operates on 24 Volts A.C. The Igniter/Flame Rod assembly can be replaced independently from the pilot burner assembly.

The hot surface igniter can be checked for resistance. A "Good" igniter will have a resistance of 10 Ohms or less. Flame current for this system should be 2.0 microamps or higher. Carrier voltage for flame signal (i.e. flame rod to valve body) is 80 volts or higher.

23. HONEYWELL SV9541Q SYSTEM OPERATION & DIAGNOSTICS

The following is the normal operating sequence for the 2-stage control system.

Cooling (Y) Request:

24 VAC signals applied to Y & G terminals of EFT (electronic fan timer) control.

- Cool motor speed energized after 5 second Cool Fan On Delay time.

Y & G signals removed from EFT.

- Cool motor speed de-energized after 60 second Cool Fan Off Delay time.

Cooling (Y) and dehumidification (Y2) requests:

- 24 VAC signals applied to Y, Y2 & G terminals of EFT (electronic fan timer) control.
- Same operation as the cooling (Y) request, except the cooling speed is reduced 20% to compensate for high humidity conditions during cooling operation. The cooling speed returns to the normal setting after the Y2 signal is removed.

Circulating Fan (G) Request:

24 VAC signals applied to G terminals of EFT control.

- Low motor speed energized without delay.

G signal removed from EFT.

- Low motor speed de-energized without delay.

NOTE1) Furnaces with DC blower motors run a low circulating fan speed in response to G request.

NOTE2) Furnaces with PSC blower motors de-energize the Low Heat fan speed during the heat exchanger warm-up period on a call for Heating that occurs during a G request.

NOTE3) Heating or Cooling requests received during a Fan request cause the fan speed to change to the appropriate heat or cool speed after the selected Fan On Delay time expires. The fan returns to circulating speed after the selected Fan Off Delay time expires following loss of the Heating or Cooling request.

Heating (W1) Request (single stage thermostat operation, 4th DIP switch must be in off position) (see furnace wiring diagram):

24 VAC signals applied to W1 terminal of EFT control.

- Inducer motor turns on at high speed.
- The high fire solenoid energizes.
- Following a 3 second prepurge delay, the pilot valve opens and the ignitor begins to warm up.
- After the pilot lights, the main burners energize and light (burners now at high fire rate).
- Timed from the opening of the main gas valve, the control will delay the selected Heat Fan On Delay time before switching the inducer to low speed, de-energizing the high fire solenoid and the fan switches to Low Heat speed.
- Timed from initial application of the Heating request, if the W1 request is still present after the selected Low Fire Delay time expires (12 minutes), the inducer switches to high speed, the high fire solenoid energizes and the fan switches to High Heat speed.

W1 signal removed from EFT.

- The gas valve de-energizes and the main burners go out.
- The inducer runs at its present speed for a 5 second postpurge period.
- The fan switches to (or stays at) Low Heat speed.
- Timed from the gas valve de-energizing, the Low Heat fan speed de-energizes after the selected Heat Fan Delay time expires.

NOTE4) If a new Heating request arrives while the control is waiting in the Heat Fan Off Delay time, the fan speed switches to

High Heat until the Heat Fan Off Delay expires or the Heat Fan On Delay expires for the new Heating request.

Heating Request (two stage thermostat operation, 4th DIP switch must be in on position) (see furnace wiring diagram):

24 VAC signals applied to W1 terminal of EFT control.

- Same response as single stage thermostat operation described above except the control will not go to high fire, High Heat fan speed unless a W2 signal is applied.

24 VAC signals applied to W1 and W2 terminals of EFT control.

- Same light-off routine as described for the signal stage thermostat operation except that at the end of the selected Heat Fan On Delay, the inducer remains on high fire, the high fire solenoid remains energized and the High Heat fan speed energizes.

NOTE5) The EFT control responds without delay to the presence or loss of W2 (with W1 constant). W1 & W2 results in high inducer, high fire and High Heat fan speed. W1 only results in low inducer, low fire and Low Heat fan speed.

Heating Request with Gas Supply Line Shut Off:

24 VAC signals applied to W1 terminal of EFT control.

- Inducer motor turns on at high speed.
- The high fire solenoid energizes.
- Following a 3 second prepurge delay, the pilot valve opens and the ignitor begins to warm up.
- The ignitor glows red-hot for 30 seconds, then turns off.
- The igniter stays off for 25 seconds, then begins to warm-up again.
- The igniter glows red-hot for 30 seconds, then turns off.
- The pilot valve closes 3 seconds after the igniter de-energizes.
- The inducer de-energizes 5 seconds after the pilot valve closes.
- The SmartValve proceeds to soft lockout and flashes error code 6.
- The control exits soft lockout after 5 minutes and begins another ignition sequence.

Gas Valve Diagnostic Codes (See Figure 4)

OFF	=	Control not powered
Heartbeat	=	Normal Operation (Standby or call for heat)
1 Flash	=	Not used
2 Flashes	=	Low Pressure switch closed when should be open
3 Flashes	=	Low Pressure switch circuit was still sensed as open 30 seconds after the inducer was energized. System is in 5 minute delay mode, with inducer off. After 5-minute delay, a new ignition sequence will be initiated. (Note: SV9541Q On/Off switch in off position during a call for heat will generate this diagnostic code)
4 Flashes	=	Limit switch string open
5 Flashes	=	Flame sensed out of sequence - Flame signal still present.
6 Flashes + 1 Note 1	=	Soft Lockout -Maximum retry count exceeded (failed to light within 4 trials for ignition)
6 Flashes + 2 Notes 1,2	=	Soft Lockout -Maximum recycle count exceeded - Last failure was Flame Sense Lost During Run, Cycling Pressure Switch or Blocked Condensate.
6 Flashes + 3 Notes 1,2	=	Soft Lockout -Maximum recycle count exceeded - Last failure was Airflow Proving Circuit Opened During Run
6 Flashes + 4 Notes 1,2	=	Soft Lockout -Maximum recycle count exceeded - Last failure was Limit Circuit Opened During Run
7 Flashes	=	Soft Lockout Due to Limit Trips Taking Longer than 2 minutes to Reset; Auto Reset After 1 Hour if Call for Heat Still Present. Reset by Cycling Call for Heat at Any Time.
8 Flashes	=	High Pressure Switch closed when should be open.
9 Flashes	=	High Pressure Switch open when should be closed.

NOTE 1: The 6 + X designation indicates a combination of flash codes: 6 flashes shows the control is in soft lockout, followed by X flashes to indicate the reason the control went into soft lockout. When the 6+ X code is flashing, the SV9541 will attempt a new ignition sequence after a five minute delay period, if the call for heat is still present. Reset of the thermostat will initiate a new ignition sequence immediately.

NOTE 2: Any combination of 5 'abnormal' events during a single call for heat will result in soft lockout. An 'abnormal' event is a Flame Sense Failure During Run, Airflow Proving Circuit Open During Run, or Limit Circuit Open During Run. The flash code will indicate which was the last 'abnormal' event that put the system into the soft lockout state based on the table above.

24. CHECKING FLAME CURRENT

The Honeywell SV9541Q Ignition system used in this furnace series proves (verifies) flame via the Flame Rectification method.

Flame Rectification is a process of converting Alternating Current (A.C.) into Direct Current (D.C.) During the ignition sequence, an alternating current (A.C.) Voltage is applied to the Flame probe.

When the burner lights the flame conducts an electrical current between the flame probe and the burner ground. Due to

the difference in size between the flame probe and the burner ground area this current flows mostly in one direction. This creates a pulsating Direct Current that flows back to the ignition control proving flame.

This flame current (D.C. Microamps) may be checked (while flame is present) using a D.C. Flame Sensor kit is available from outside vendors.

25. CAPACITORS

Figure 31

Checking Capacitor

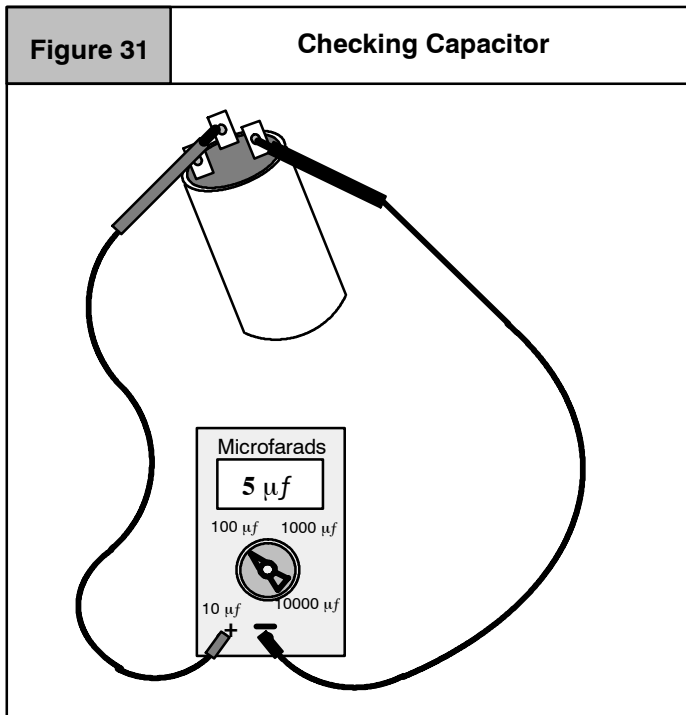

Permanent Split Capacitor (P.S.C.) motors are used on the circulating (conditioned air) blower of 2 Speed models and on the exhaust (combustion) blower of condensing models. Before replacing one of these motors (assumed to be bad) the condition of its capacitor should be verified, since **it**, and not the motor, may be the source of the problem.

Note: *9MPT models use PSC motors on circulating blower and on the 125 exhaust blower).

Before checking **any** capacitor, the supply power to the unit should be turned "OFF". The capacitor should then be discharged (through a resistor) before testing. A 20,000 Ohm 2 Watt resistor can be used for this purpose.

The condition of the capacitor should then be verified with a capacitor analyzer (one that indicated the capacitor's value in microfarads) rather than with an Ohmmeter. The reason for this, is that an Ohmmeter test can only indicate if a capacitor is "OPEN", or "SHORTED", it cannot verify if its value (microfarads) is within an acceptable range.

Capacitor should test to within 10% of its rated value. Capacitors testing outside this range should be replaced. A weak capacitor can be the cause of a motor failing to start.

26. BLOWER ASSEMBLY

All variable Speed models use one of two different variable speed (D.C. motor), direct-drive, blower assemblies. Different size (HP) motors and/or different diameter blower wheels are used in the different models to obtain the required air flow.

All 2 Speed models use a multi-speed, permanent split capacitor motor, direct-drive, blower assembly. Different size (HP) motors and/or different diameter blower wheels are used in each model to obtain the required air flow.

In all models entire blower assembly slides out on rails for servicing after removing the two screws at the front of the blower deck.

CHECKING BLOWER MOTOR

Variable Speed Models - D.C. Motor

The D.C. Motor used in the variable speed models *Cannot*

be checked accurately using traditional methods. An Ohmmeter test will tell little or nothing about the condition of the motor. Because of this a "Special" test method is required to determine if the motor is good or bad.

The condition of this motor can **ONLY** be verified as follows: With the thermostat calling for operation in the desired mode, and line voltage applied to the motor, Check for 24 Volts across the "Common" (Blue) wire and the desired "Speed" wire of the six (6) pin connector *at the motor*. With 24 VAC **present**, motor should run. If the motor Does Not run, it is faulty and must be replaced. If 24 VAC **is not** present, a problem is indicated in the thermostat, wiring, or ST9162A.

Figure 32		Variable Speed Models D.C. Motor Speed Wires	
Wire Color		Motor Speed	
Blue		Common	
White		Low Heat	
Green		Circulating	
Black		High Heat	
Yellow		Cooling	
Brown		Dehum. (80%)*	

* Function enabled only when energized with cooling speed. Motor runs at 80% of cooling speed.

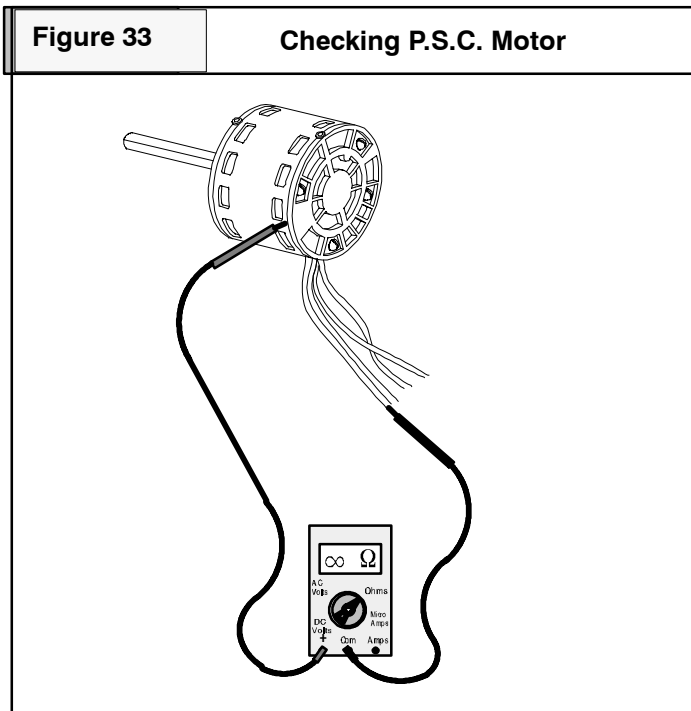

2 Speed Models - P.S.C. Motor

The P.S.C. motor used in 2 speed models may be checked using traditional Ohmmeter test methods. I.E. Checking from any speed tap lead (black, orange, blue, or red) to Neutral (white) should indicate continuity. While checking from any motor lead to the motor case should indicate infinity (no continuity). Before condemning any P.S.C. motor be sure to verify the condition of its capacitor.

SELECTING BLOWER SPEEDS

The wide variety of applications and installations of furnaces throughout the country makes it impossible to “Factory Select” blower speeds that will provide proper operation for all installations. This means then, that the blower speeds for both heating and cooling must be “Field Se-

lected” for each particular installation to insure proper operation.

The criteria for selecting the proper blower speeds **IS NOT** “High for Cooling, Low for Heating”. Although that may be how it works out SOMETIMES, It can (in many cases) be exactly the opposite. (I.E. a Lower speed for Cooling, and a Higher speed for Heating)

The PROPER CRITERIA FOR SELECTING BLOWER SPEEDS is as follows:

HEATING

A blower speed must be selected that will provide proper temperature rise through the furnace. (See “checking temperature rise” found on page 9 of this manual). The required CFM for a particular temperature rise can also be calculated by using the following formula:

$$\frac{\text{Output BTU}}{\text{Temp. Rise X 1.08}} = \text{CFM}$$

EXAMPLE: Using a 75 Mbtu Non-Condensing furnace (equipped with P.S.C. motor) of this series with an output of 60,000 Btuh and a desired temperature rise of 50 °F (range of 35–65 °F allowable) and a **measured** external static pressure of 0.2” W.C. while operating on medium-low speed with a dry coil.

$$\frac{60,000}{50 \times 1.08} \text{ or } \frac{60,000}{59.4} = 1010 \text{ CFM}$$

Checking the blower performance data for this model, (see **Table 7**) indicates that @ 0.2” W.C. E.S.P. medium-low speed delivers 1030 CFM. Accordingly, medium-low speed is the proper speed to be used in this example for the HEATING speed.

COOLING

A blower speed must be selected that will provide proper air flow (Nominal 400 CFM per ton) for the size (capacity) air conditioning coil being used at the external static pressure of the Duct system (installation). This requires CHECKING THE EXTERNAL STATIC PRESSURE, and then consulting the BLOWER PERFORMANCE DATA to determine the required speed tap.

EXAMPLE: A 24,000 BTU (2 ton) air conditioning system, using the same 75,000 BTU furnace as in the previous example. The external static pressure is measured with the unit operating on Low speed, and found to be 0.4” W.C. with a wet coil.

400 CFM (nominal) per ton required

400 X 2 = 800 CFM required

Checking the blower performance data (see **Table 7**) for this model indicates that @ 0.4” W.C. ESP low speed is delivering 735 CFM. Accordingly, low speed is the proper speed to be used in this example for the COOLING speed.

Table 7

Blower Performance Data 75,000 BTUH (PSC Motor)

Air Delivery in Cubic Feet per Minute (CFM) (Furnace Rated @ 0.5" W.C. ESP)					
External Static Pressure Inches of W.C.	TAP	LOW	MED L	MED H	HIGH
	.10	706	917	1163	1368
	.20	677	875	1120	1319
	.30	636	840	1076	1263
	.40	595	812	1031	1202
	.50	546	766	987	1148
	.60	490	702	889	1077
	.70	---	630	821	989
	.80	---	550	750	914
	.90	---	462	676	833
	1.0	---	---	601	747

Always check current "Technical Support Manual"

EXTERNAL STATIC PRESSURE (ESP)

External Static Pressure can best be defined as the pressure difference (drop) between the Positive Pressure (discharge) and the Negative Pressure (intake) sides of the blower. External Static Pressure is developed by the blower as a result of resistance to airflow (Friction) in the air distribution system EXTERNAL to the furnace cabinet. (i.e pressure inside duct)

Resistance applied **externally** to the furnace (I.E. Duct work, Coils, Humidifiers, Filters, Etc.) on either the Supply or Return side of the system, causes an INCREASE in External Static Pressure, accompanied by a REDUCTION in airflow.

ESP is affected by two (2) factors.

1. Resistance to Airflow as explained above.
2. Blower Speed. Changing to a higher or lower blower speed tap will raise or lower the External Static Pressure accordingly.

These effects MUST be understood and taken into consideration when checking ESP/ Airflow to insure that the system is operating within design conditions.

Operating a system with Insufficient or Excessive air flow can cause a variety of different operating problems. Among these are premature heating component and/or compressor failures, reduced capacity, freezing evaporator coils, etc.

System air flow should ALWAYS be verified upon completion of a new installation, or BEFORE a change-out, heat exchanger replacement, or in the case of a compressor failure to insure that the failure was not caused by improper air flow.

Figure 34

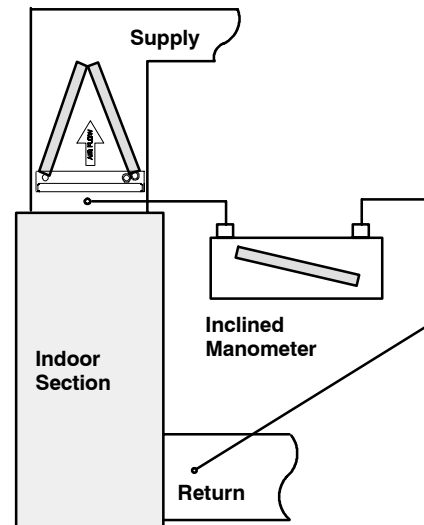
Checking Static Pressure**CHECKING EXTERNAL STATIC PRESSURE**

The air flow through the unit can be determined by measuring the external static pressure of the system, and consulting the blower performance data for the particular model furnace you have.

1. Set up to measure external static pressure at the supply and return duct connections (See Figure 34).
2. Drill holes in the ducts for pressure taps, pitot tubes, or other accurate pressure sensing devices.
3. Connect these taps to a level inclined manometer or Magnehelic gauge.
4. Ensure the coil and filter are clean, and all the registers are open.
5. Determine the external static pressure with the blower operating.
6. Refer to the Air Flow Data for your particular furnace to find the actual airflow for the current speed tap (or dip switch setting).
7. If the Actual airflow is either too high, or too low, the blower speed tap (or dip switch setting) will need to be changed.
8. Refer to Changing Blower Speeds on the pages that follow for the proper procedure.
9. Select the speed tap (or dip switch setting) that appears to most closely provide the required air flow for the system.
10. Recheck the external static pressure with the new speed tap. External static pressure (and actual airflow) will both have changed (either higher, or lower), depending upon speed tap selected. Recheck the actual airflow (at this "new" static pressure) to confirm speed tap selection.
11. Repeat steps 9. and 10. (if necessary) until proper Speed Tap (and airflow) has been obtained.

Figure 35

Checking Temperature Rise

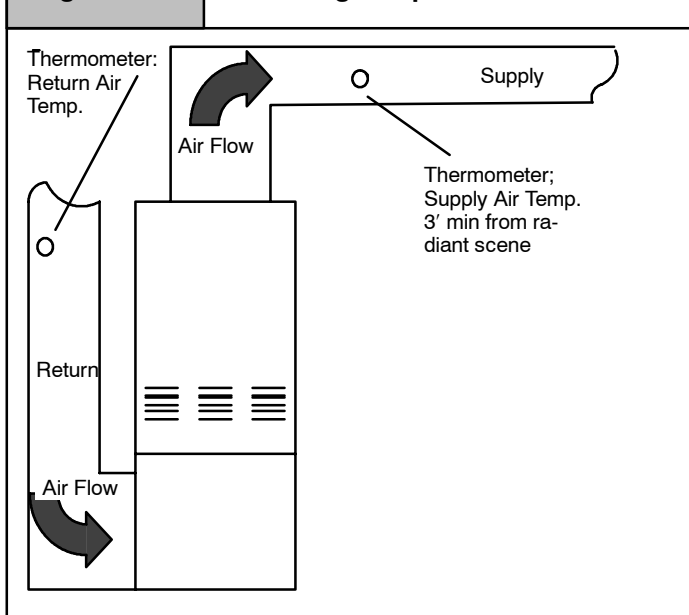

NOTE: This same method can be used (on models equipped with a P.S.C. motor) to determine the COOLING airflow, by TEMPORARILY connecting the cooling speed tap wire to the HEAT terminal of the FAN Control. NEVER connect two (2) speed tap wires to the same terminal. Doing so will cause motor failure.

VARIABLE SPEED MODELS - D.C. MOTOR

The heating, cooling and circulating blower speeds can be adjusted by changing the switch settings that are located on the side of the blower motor (see **Figure 36**). Switches #1 and #2 adjust the circulating blower speed. Switches #3, #4 and #5 adjust the heating speeds. Switches #6, #7 and #8 adjust the cooling speed. See the Technical Service Data Sheet for the model you are servicing to obtain the switch settings for the desired airflow rates.

CHANGING BLOWER SPEEDS

The procedure for changing blower speeds (if needed) differs based on whether the unit is a variable speed model, or a 2 speed model.. (See Figure 36 and Figure 38 and the appropriate sections for the model you are servicing).

CHECKING APPROXIMATE AIR FLOW

If an inclined manometer or Magnehelic gauge IS NOT available to check the External Static Pressure, OR the blower performance data is unavailable for your furnace, *approximate air flow* can be calculated by **Measuring** the temperature rise, then using the following criteria:

The approximate CFM actually being delivered can be calculated (if the OUTPUT Btu of the furnace is known) by operating the system in HEATING, and using the following formula:

$$\frac{\text{Output BTU}}{\text{Temp. Rise} \times 1.08} = \text{CFM}$$

EXAMPLE: Using a (75 Mbtu Input) furnace with an OUTPUT of 59,000 Btuh and a measured temperature rise of 50°F.

$$\frac{59,000}{50 \times 1.08} \text{ or } \frac{59,000}{54} = 1093 \text{ CFM}$$

⚠ WARNING

Electrical shock hazard.

Turn OFF power to furnace before changing blower speeds.

Failure to do so can result in personal injury and/or death.

VARIABLE SPEED MODELS - D.C. MOTOR

The heating, cooling and circulating blower speeds can be adjusted by changing the switch settings that are located on the side of the blower motor (see **Figure 36**). Switches #1 and #2 adjust the circulating blower speed. Switches #3, #4 and #5 adjust the heating speeds. Switches #6, #7 and #8 adjust the cooling speed. See the Technical Service Data Sheet for the model you are servicing to obtain the switch settings for the desired airflow rates.

Figure 36

Blower Motor Control

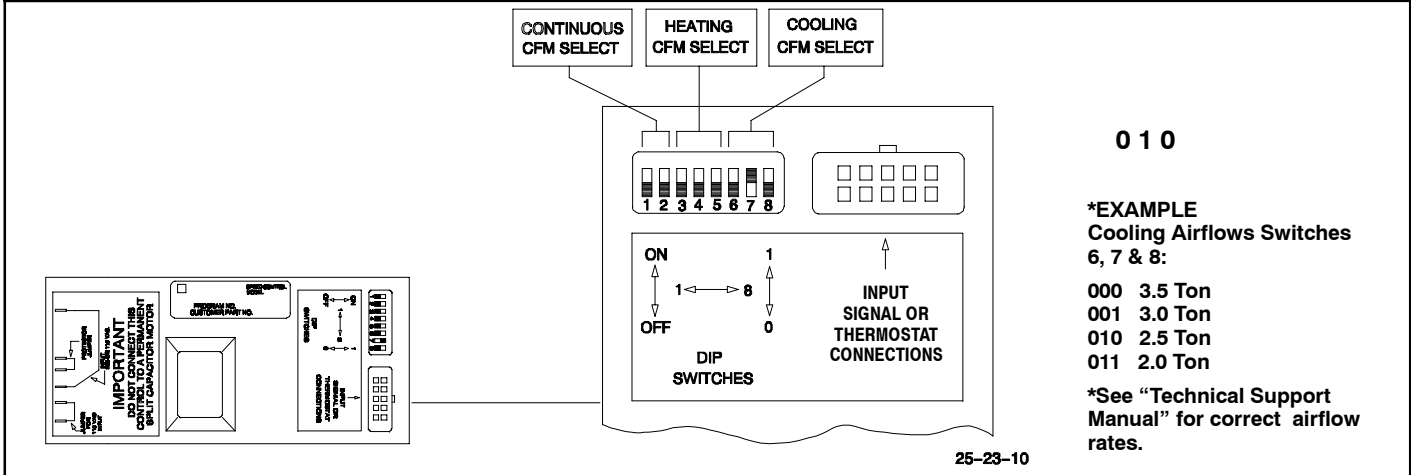

NOTE: Power must be completely OFF to unit any time switch settings are changed or settings will not take effect.

Heating, Cooling & Continuous Airflow Settings

Continuous Blower (CFM) @ 0.10" Static

Switch Settings		Furnace Model			
#1	#2	50K	75K	100K	125K
0*	0*	540	540	700	703
0	1	660	660	860	821
1	0	780	780	1020	1000
1	1	900	900	1180	1160

*Factory Setting

Lo Heat Air Temperature Adjustment (° F)**

Switch Settings			Furnace Model			
#3	#4	#5	50K	75K	100K	125K
0**	0**	0**	0	0	0	0
0	0	1	1	1	1	6
0	1	0	4	2	2	8
0	1	1	7	3	5	12
1	0	0	11	6	8	16
1	0	1	-7	-4	-5	-1
1	1	0	-11	-6	-9	-4
1	1	1	-15	-9	-11	-7

*Factory setting

Hi Heat Air Temperature Adjustment (° F)**

Switch Settings			Furnace Model			
#3	#4	#5	50K	75K	100K	125K
0**	0**	0**	0	0	0	0
0	0	1	3	2	3	2
0	1	0	6	4	5	6
0	1	1	14	6	9	11
1	0	0	17	11	13	13
1	0	1	-8	-4	-4	-5
1	1	0	-13	-4	-7	-5
1	1	1	-17	-4	-9	-5

*Factory setting

**Approximate air temperature change from factory setting @ 0.20" static on high heat).

2 SPEED MODELS - P.S.C. MOTOR

HEATING SPEEDS

Should it be necessary to change blower speeds to obtain proper temperature rise on either (or both) High fire, and/or Low Fire, Simply take the appropriate speed tap wire, and plug it on to the terminal marked "HEAT HIGH" or "HEAT LOW" respectively on the HONEYWELL ST9162A control.

Figure 37	2 Speed Models Blower Speed Taps	
	Wire Color	Motor Speed
	Black	High
	Orange	Medium-High
	Blue	Medium-Low
	Red	Low

COOLING SPEED

When the proper speed has been determined, simply plug it on to the terminal marked "COOL" on the HONEYWELL ST9162A control.

"M1" & "M2" TERMINALS

There are two (2) terminals (marked "M1" & "M2") on the HONEYWELL ST9162A control which have no internal

connection to the control. Their purpose is to provide a place to connect, or "PARK" any "UNUSED" speed tap wires (P.S.C. motors ONLY) to keep them out of the way and prevent them from shorting out against the furnace casing, or each other.

Figure 38

Honeywell ST9162

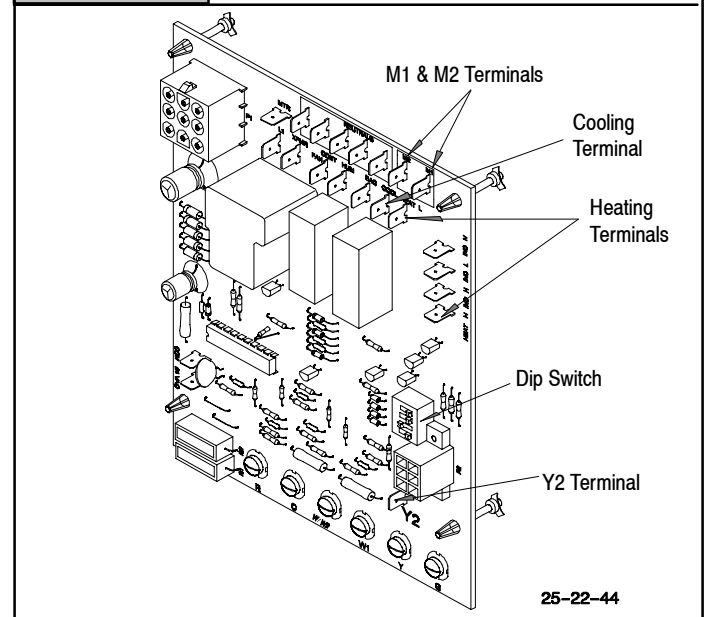

27. BLOWER ROTATION

- The startup of a furnace will involve a cycle or two of the furnace to properly prime the condensate trap with water. Until the trap is fully primed, some condensate will be pulled into the combustion blower. The furnace may cycle on the pressure switch connected to the plastic transition box due to condensate buildup. After the trap is primed, the condensate will start draining from the furnace. The combustion blower will clear out any remaining condensate in the blower housing through the vent fitting downstream of the blower. Note that the condensate trap can also be primed by pouring water into the vent drain side of the trap. Remove the small plastic cap and clamps from the unused drain stub on the vent drain side of the condensate trap. Connect a section of the $\frac{5}{8}$ " OD hose with a funnel to the drain stub and pour eight (8) ounces of water into the trap. Remove the hose and replace the plastic cap and clamp. This will prime both the vent and the transition sides of the trap.
- The startup of a furnace will have "milky or oily" looking condensate coming from the furnace. This is residual drawing lube in the secondary heat exchanger that is being washed out by the condensate. The condensate will clear up as the

furnace operates. Poisonous carbon monoxide gas hazard.

- The use of a vent tee at the outlet of the condensate trap is not required if the condensate drain line from the trap to the open drain is properly sloped ($\frac{1}{4}$ " per foot downward slope). Do not trap the drain line in any other location than at the condensate trap.
- The combustion blowers and blower gaskets are different on some of the furnace models. There are two part numbers of the combustion blower for the 2-stage furnace models. (See the *Tech. Manual* for the correct part number for the furnace.) Besides the part number difference, the 50M, 75M and 100M BTUH models use the shaded pole motor version with the $1\frac{7}{8}$ " diameter back plate with a raised lip. The blower gasket is approximately $2\frac{3}{4}$ " outside diameter and is positioned into the recessed opening in the transition. The 125M BTUH models use the PSC motor version with the 2" diameter back plate with no lip. The blower gasket is approximately $3\frac{1}{4}$ " outside diameter and is positioned on the flat surface of the transition. A mismatch of blower backplated and/or gaskets can cause the furnace to cycle on the pressure switch or to not operate. This could be misread as a condensate drainage problem.

Figure 39

Upflow Installations (Dual Certified *9MPT & *9MPV(A1) Models)

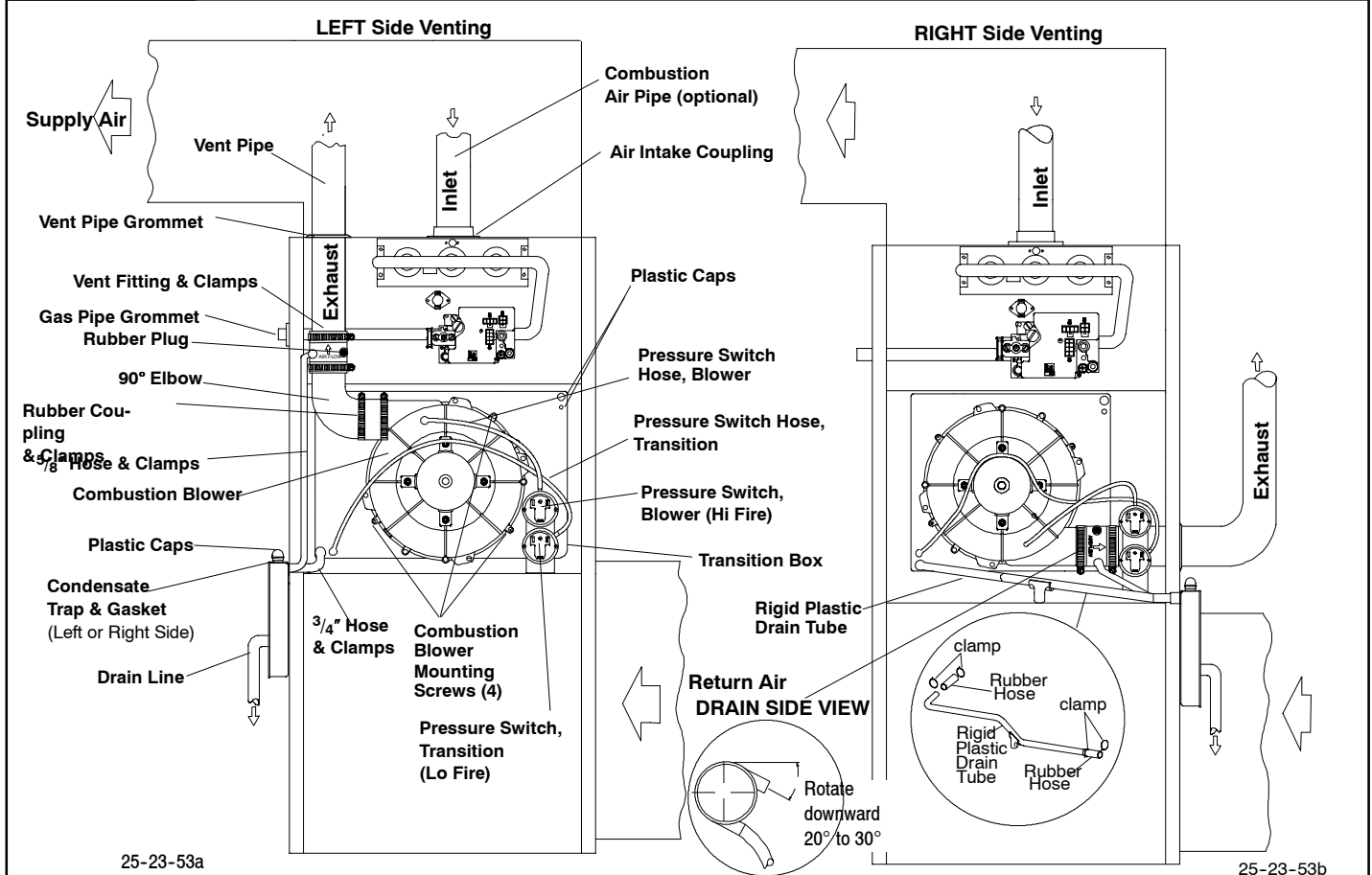

Upflow Installations - (Dual Certified *9MPT & *9MPV) (See Figure 39)

Mount the condensate drain trap in a vertical position to either the left or right side of the furnace using the two screws and gasket that are provided. If needed, remove the hole plugs from the furnace side panel and relocate to the open set of holes in the opposite side panel. Drill two $\frac{7}{64}$ " diameter holes in the casing using the condensate trap as the template.

Ensure that the vent fitting and the 90° elbow is securely attached to the combustion blower.

This configuration allows left side venting from the furnace. If right side venting is required, the combustion blower must be relocated on the plastic transition box. Remove the four(4) screws that secure the blower to the transition. Rotate the blower 180° and secure with the four(4) screws. Use caution to not over tighten the screws to prevent stripping out of the plastic mounting holes.

For right side venting, remove vent fitting assembly from combustion blower. Remove 90° elbow and rubber tubing from the vent fitting by loosening the clamp on the vent fitting. Securely attach vent fitting directly to combustion blower.

NOTE: The vent fitting **MUST** be installed with the airflow marking arrow pointed toward the vent pipe, with the drain stub at a 20° to 30° downward slope.

Plug the right drain stub of the vent fitting with the rubber plug. Use a blunt pointed screwdriver to push the plug into the stub.

For left side mounted condensate trap, connect the $\frac{3}{4}$ " OD rubber hose with the 90° bend to the drain stub on the bottom of the plastic transition box and secure with a $\frac{3}{4}$ " clamp.

Route the hose to the large drain stub on the condensate trap. Cut off excess hose and discard. Connect the hose to the drain stub on the trap and secure with a $\frac{3}{4}$ " clamp.

For right side mounted condensate trap, the rigid plastic drain tube **MUST** be used. Cut two 2" long sections from the $\frac{3}{4}$ " OD rubber hose. Connect the plastic drain tube to the drain stub on the bottom of the plastic transition box and to the stub on the condensate trap using the two hose sections and $\frac{3}{4}$ " clamps.

NOTE: The support leg on the plastic drain tube **MUST** be positioned on the blower partition.

Connect the $\frac{5}{8}$ " OD rubber hose with the 90° bend to the left drain stub on the vent fitting and secure with a $\frac{5}{8}$ " clamp.

Route the hose to the small drain stub on the condensate trap. Cut off excess hose and discard. Connect the hose to the drain stub on the trap and secure with a $\frac{5}{8}$ " clamp.

NOTE: Ensure hoses maintain a downward slope to the condensate trap with no kinking or binding for proper condensate drainage.

Figure 40

Horizontal Left Installations (Dual Certified *9MPT & *9MPV(A1) Models)

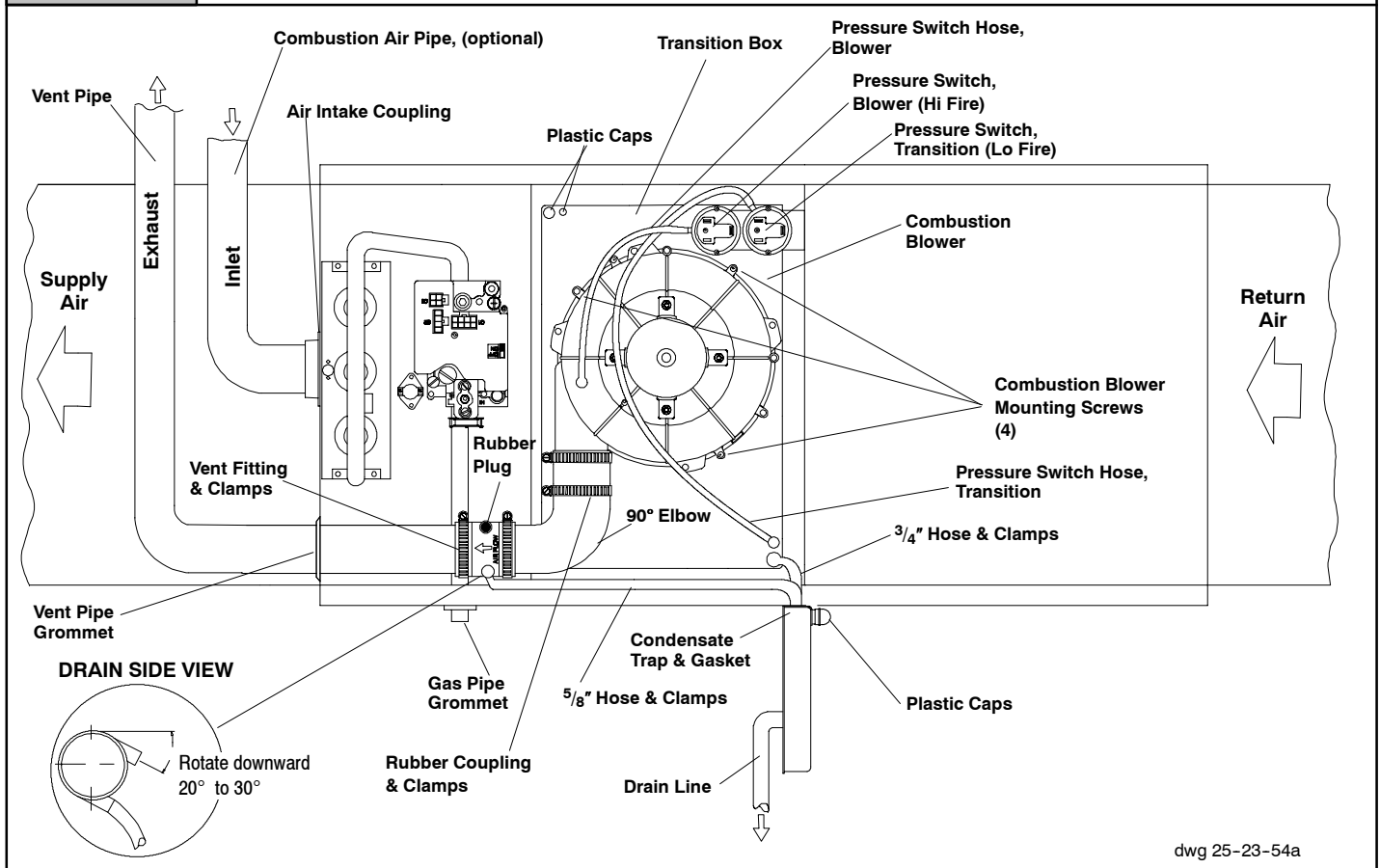

Horizontal Left Installations - (Dual Certified *9MPT & *9MPV) (See Figure 40)

Relocate the plastic caps and clamps on the condensate drain trap from the vertical drain stub to the horizontal drain stubs. Secure the clamps tightly to prevent condensate leakage.

Mount the condensate drain trap in a vertical position to the left side of the furnace using the two screws and gasket that are provided. Note: The condensate trap will be located under the furnace in a vertical position when the furnace is placed horizontally on the left side. If needed, remove the hole plugs from the furnace side panel and relocate to the open set of holes in the opposite side panel. Drill two $\frac{7}{64}$ " diameter holes in the casing using the condensate trap as the template.

Ensure that the vent fitting and the 90° elbow is securely attached to the combustion blower.

NOTE: The vent fitting **MUST** be installed with the airflow marking arrow pointed toward the vent pipe, with the drain stub at a 20° to 30° downward slope.

Plug the upper drain stub on the vent fitting with the rubber plug. Use a blunt pointed screwdriver to push the plug into the stub.

Connect the $\frac{3}{4}$ " OD rubber hose with the 90° bend to the drain stub on the bottom of the plastic transition box and secure with a $\frac{3}{4}$ " clamp.

Route the hose to the large drain stub on the condensate trap. Cut off excess hose and discard. Connect the hose to the drain stub on the trap and secure with a $\frac{3}{4}$ " clamp.

Connect the $\frac{5}{8}$ " OD rubber hose with the 90° bend to the small drain stub on the trap and secure with a $\frac{5}{8}$ " clamp.

Route the hose to the lower drain stub on the vent fitting. Cut off excess hose and discard. Connect the hose to the drain stub on the vent fitting and secure with a $\frac{5}{8}$ " clamp.

NOTE: Ensure hoses maintain a downward slope to the condensate trap with no kinking or binding for proper condensate drainage.

Figure 41

Horizontal Right Installations (Dual Certified *9MPT & *9MPV)

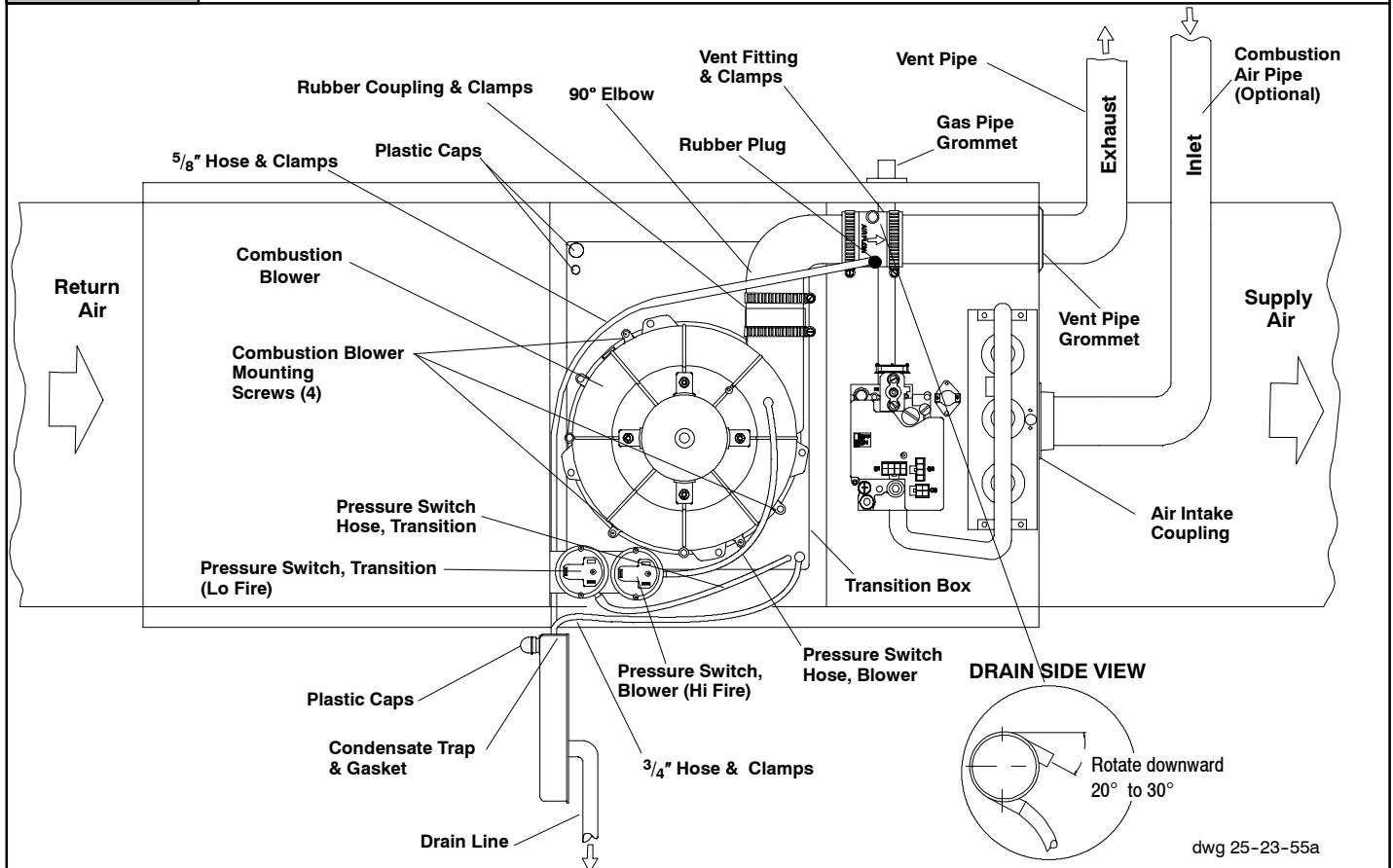

Horizontal Right Installations - (Dual Certified *9MPT & *9MPV) (See Figure 41)

Relocate the plastic caps and clamps on the condensate drain trap from the vertical drain stub to the horizontal drain stubs. Secure the clamps tightly to prevent condensate leakage.

Mount the condensate drain trap in a vertical position to the right side of the furnace using the two screws and gasket that are provided. Note: The condensate trap will be located under the furnace in a vertical position when the furnace is placed horizontally on the right side. If needed, remove the hole plugs from the furnace side panel and relocated to the open set of holes in the opposite side panel. Drill two $\frac{7}{64}$ " diameter holes in the casing using the condensate trap as the template.

Ensure that the vent fitting and the 90° elbow is securely attached to the combustion blower.

NOTE: The vent fitting MUST be installed with the airflow marking arrow pointed toward the vent pipe, with the drain stub at a 20° downward slope.

Plug the upper drain stub on the vent fitting with the rubber plug. Use a blunt pointed screwdriver to push the plug into the stub.

Remove the pressure switch hose from the upper stub on the plastic transition box.

Relocate the plastic caps on the stubs of the plastic transition box from the lower stubs to the upper stubs and secure tightly with the clamps.

Route the pressure switch hose to the lower stub on the plastic transition box. Cut off excess hose and discard. Connect the pressure switch hose to the lower stub on the plastic transition box. **NOTE:** Failure to correctly install the pressure switch hose to the transition can adversely affect the safety control operation.

Connect the $\frac{3}{4}$ " OD rubber hose with the 90° bend to the drain stub on the bottom of the plastic transition box and secure with a $\frac{3}{4}$ " clamp.

Route the hose to the large drain stub on the condensate trap. Cut off excess hose and discard. Connect the hose to the drain stub on the trap and secure with a $\frac{3}{4}$ " clamp.

Connect the $\frac{5}{8}$ " OD rubber hose with the 90° bend to the lower drain stub on the vent fitting and secure with a $\frac{5}{8}$ " clamp.

Route the hose to the smaller drain stub on the condensate trap. Cut off excess hose and discard. Connect the hose to the drain stub on the trap and secure with a $\frac{5}{8}$ " clamp.

NOTE: Ensure hoses maintain a downward slope to the condensate trap with no kinking or binding for proper condensate drainage.

Figure 42

Downflow Installations (Dual Certified *9MPT & *9MPV Models(A1) Models)

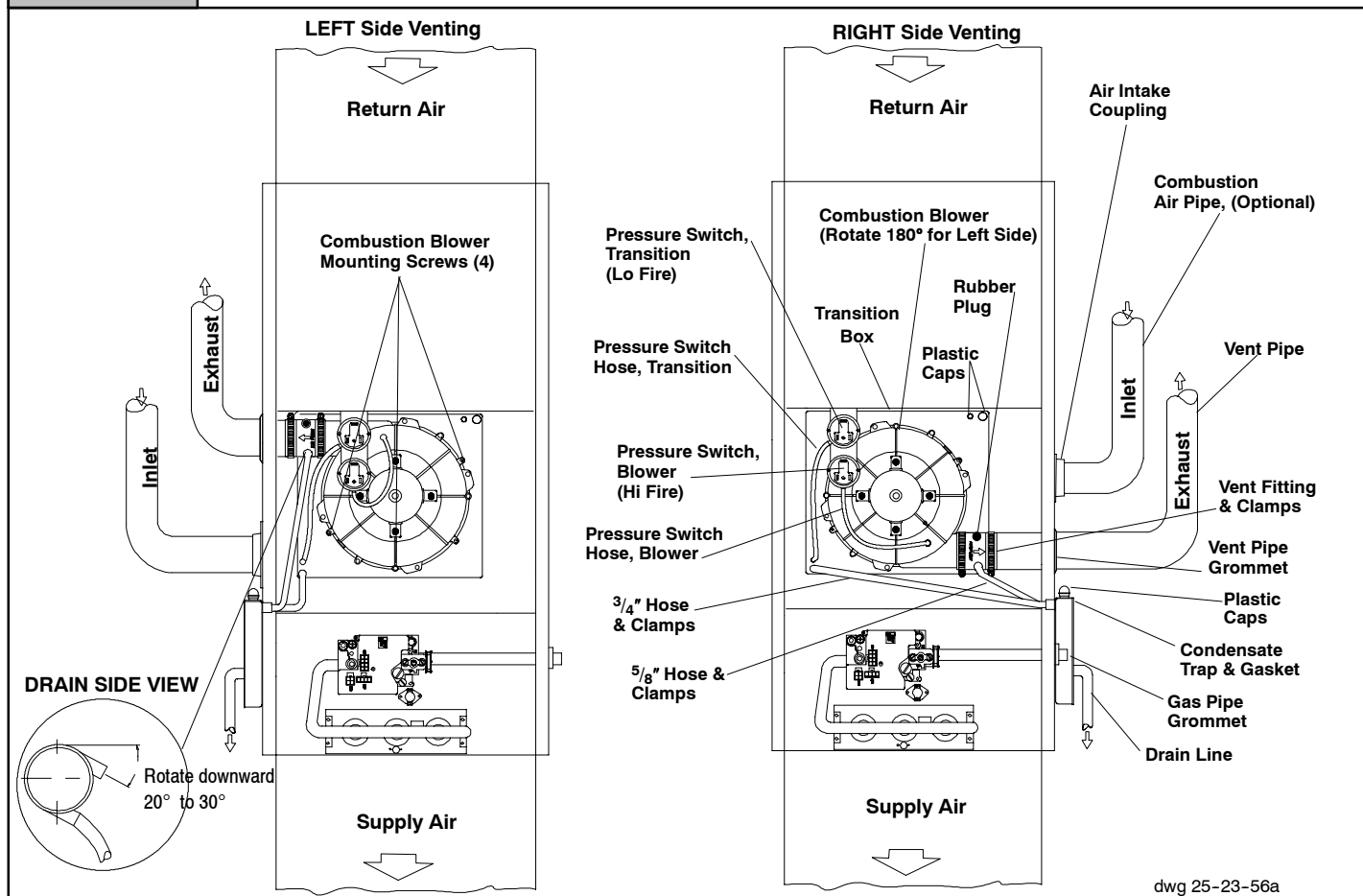

dwg 25-23-56a

Downflow Installations - (Dual Certified *9MPT & *9MPV Models) (See Figure 42)

Mount the condensate drain trap in a vertical position to either the right or left side of the furnace using the two screws and gasket that are provided. If needed, remove the hole plugs from the furnace side panel and relocate to the open set of holes in the opposite side panel. Drill two $\frac{7}{64}$ " diameter holes in the casing using the condensate trap as the template.

Ensure that the vent fitting is securely attached to the combustion blower using the clamp.

NOTE: The vent fitting **MUST** be installed with the airflow marking arrow pointed toward the vent pipe, with the drain stub at a 20° to 30° downward slope.

For right side venting, remove vent fitting assembly from combustion blower. Remove 90° elbow and rubber tubing from the vent fitting by loosening the clamp on the vent fitting. Securely attach vent fitting directly to combustion blower.

This configuration allows right side venting from the furnace. If the left side venting is required, the combustion blower must be relocated on the plastic transition box. Remove the three(4) screws that secure the blower to the transition. Rotate the blower 180° and secure with the three(3) screws. Use caution to not over tighten the screws to prevent stripping out of the plastic mounting holes.

Plug the upper drain stub on the vent fitting with the rubber plug. Use a blunt pointed screwdriver to push the plug into the stub.

Remove the pressure switch hose from the upper stub on the plastic transition box.

Relocate the plastic caps on the stubs of the plastic transition box from the lower stubs to the upper stubs and secure tightly with the clamps.

Route the pressure switch hose to the lower stub on the plastic transition box. Cut off excess hose and discard. Connect the pressure switch hose to the lower stub on the plastic transition box. **NOTE:** Failure to correctly install the pressure switch hose to the transition box can adversely affect the safety control operation.

Connect the $\frac{3}{4}$ " OD rubber hose with the 90° bend to the drain stub on the bottom of the plastic transition box and secure with a $\frac{3}{4}$ " clamp.

Route the hose to the large drain stub on the condensate trap. Cut off excess hose and discard. Connect the hose to the drain stub on the trap and secure with a $\frac{3}{4}$ " clamp.

Connect the $\frac{5}{8}$ " OD rubber hose with the 90° bend to the lower stub on the vent fitting and secure with a $\frac{5}{8}$ " clamp.

Route the hose to the smaller stub on the condensate trap. Cut off excess hose and discard. Connect the hose to the drain stub on the trap and secure with a $\frac{5}{8}$ " clamp.

NOTE: Ensure hoses maintain a downward slope to the condensate trap with no kinking or binding for proper condensate drainage.

440 08 2002 02

Figure 43

Upflow Installations (Dual Certified *9MPT & *9MPV-A2 Models)

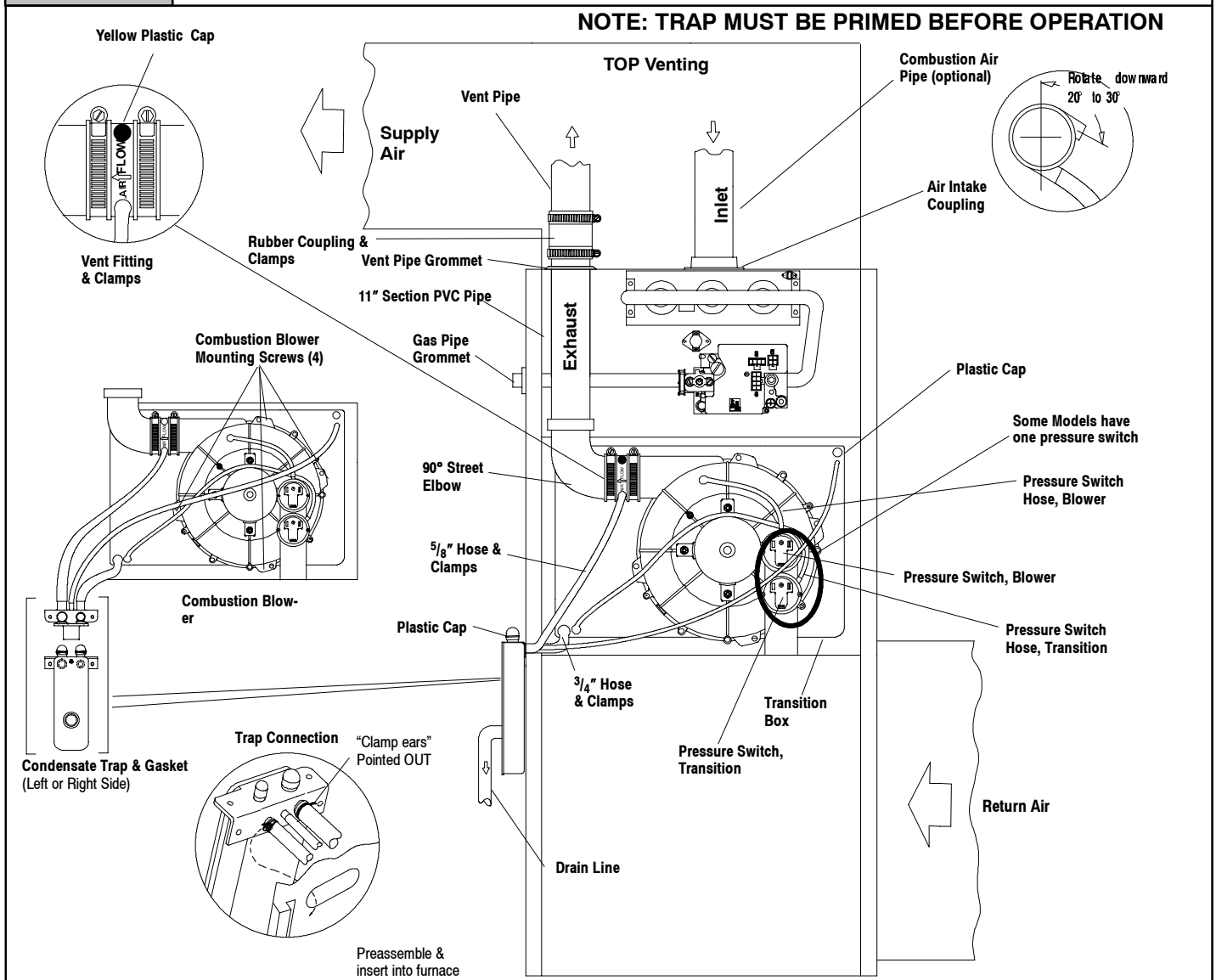

Upflow Installations - (Dual Certified *9MPT & *9MPV) (See Figure 43)

Note: For easier installation of the drain hoses and clamps to the condensate trap, follow the directions outlined below except do not make any clamp connections to any of the drain stubs and hoses until the hose routing and lengths have been determined. Remove the condensate trap and drain hoses from the furnace and secure the drain hoses to the drain stubs on the trap with the hose clamps (position the clamps as shown in **Figure 43**). Install the condensate trap/hose assembly to the furnace casing. Hook one side of the "clamp ears" on the drain stub through the hole in the casing and push the condensate trap into position. Secure with the two screws. Reconnect the drain hoses to the stubs on the vent fitting and the plastic transition and secure with the clamps.

Mount the condensate drain trap in a vertical position to either the left or right side of the furnace using the two screws and gasket that are provided. If needed, remove the hole plugs from the furnace side panel and relocate to the open set of holes in the opposite side panel.

NOTE: All gaskets and seals must be in place for sealed combustion applications.

Ensure that the vent fitting and the 90° street elbow are securely attached to the combustion blower using the clamps.

Plug the upper drain stub on the vent fitting with the yellow plastic cap.

Glue the 11" section of PVC pipe to the 90° street elbow after checking the fit up. (Follow the procedures outlined in the *Joining Pipe and Fittings* section of this manual, page 30.) The PVC pipe will extend through the top panel about 1 1/2". Connect the rubber coupling to the end of the 11" section of PVC pipe using the clamp.

Note: There will be some misalignment of the PVC pipe inside the furnace. The rubber coupling will straighten out the misalignment at the vent pipe connection at the top of the furnace.

For left side venting, remove 90° street elbow from the vent fitting by loosening the clamp on the vent fitting. Securely attach vent fitting to combustion blower.

NOTE: For left side venting, the vent fitting **MUST** be installed with the airflow marking arrow pointed toward the vent pipe, with the drain stub at a 20° to 30° downward slope.

This configuration allows left side venting from the furnace. If right side venting is required, the combustion blower must be relocated on the plastic transition box. Remove the four(4) screws that secure the blower to the transition. Rotate the blower 180° and secure with the four(4) screws. Use caution to not over tighten the screws to prevent stripping out of the plastic mounting holes.

NOTE: For right side venting, the vent fitting **MUST** be installed with the airflow marking arrow pointed toward the vent pipe, with the drain stub at a 5° to 10° downward slope. (See **Figure 44**)

Plug the upper drain stub on the vent fitting with the yellow plastic cap.

For left side mounted condensate trap, connect the $\frac{3}{4}$ " OD rubber hose with the 90° bend to the large drain stub on the condensate trap and secure with a $\frac{3}{4}$ " clamp.

Route the hose to the drain stub on the bottom of the plastic transition box. Cut off excess hose and discard. Connect the hose to the drain stub on the transition and secure with a $\frac{3}{4}$ " clamp.

For right side mounted condensate trap, connect the $\frac{3}{4}$ " OD rubber hose with the 90° bend to the bottom of the plastic transition box and secure with a $\frac{3}{4}$ " clamp.

Route the hose to the large drain stub on the condensate pump. Cut off excess hose and discard. Connect the hose to the drain stub on the condensate trap and secure with a $\frac{3}{4}$ " clamp.

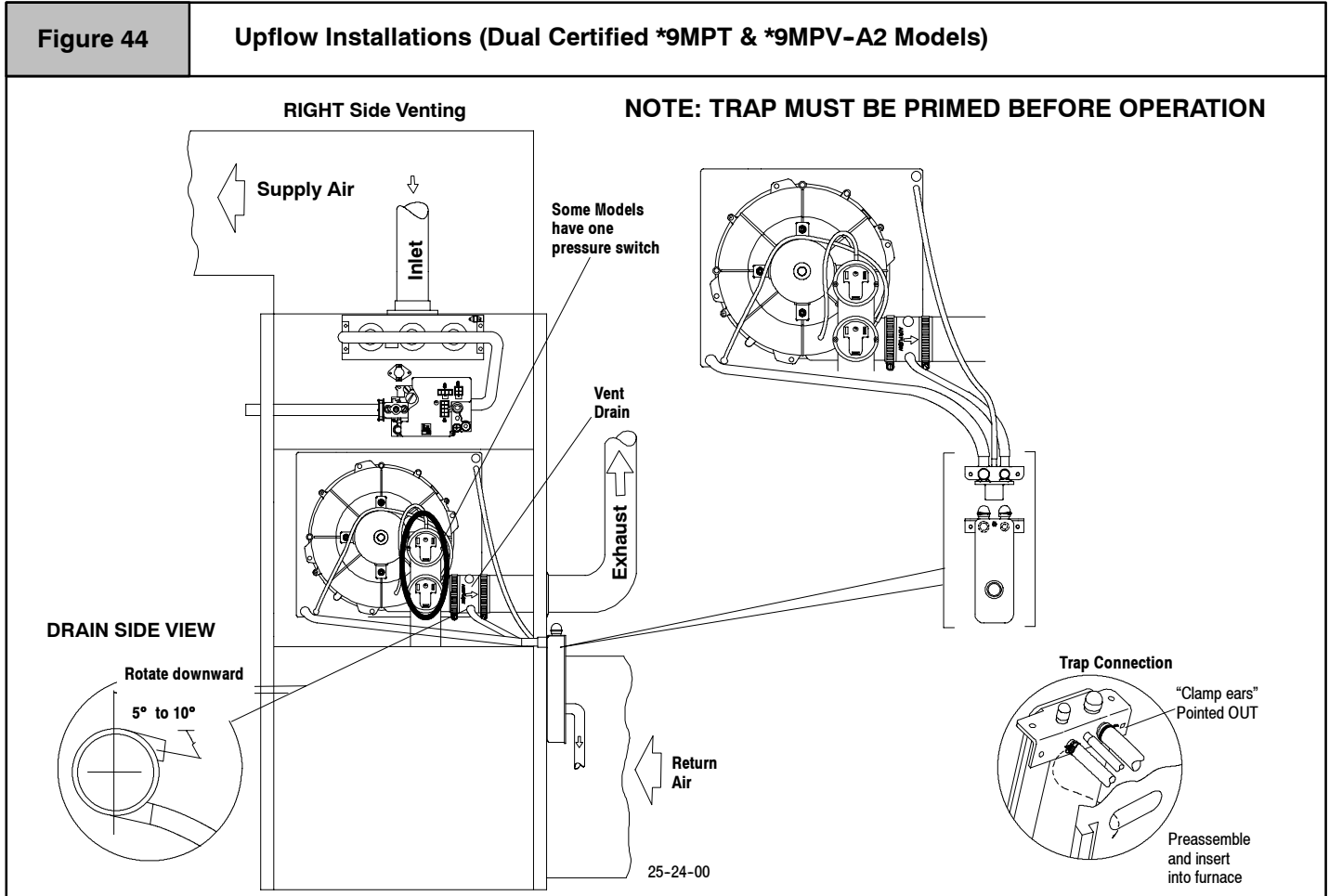

For left or right side mounted condensate trap, the pressure tap on the condensate trap **MUST** be connected to the unused pressure tap located on the upper right hand corner of the plastic transition box. Remove the plastic caps from the pressure taps on the condensate trap and the plastic transition and connect with the $\frac{5}{16}$ " OD rubber hose. (See **Figure 43** and **Figure 44**)

Connect the $\frac{5}{8}$ " OD rubber hose with the 90° bend to the lower

drain stub on the vent fitting and secure with a $\frac{5}{8}$ " clamp.

Route the hose to the small drain stub on the condensate trap. Cut off excess hose and discard. Connect the hose to the drain stub on the trap and secure with a $\frac{5}{8}$ " clamp.

NOTE: Ensure hoses maintain a downward slope to the condensate trap with no kinking or binding for proper condensate drainage.

Figure 45

Horizontal Left Installations (Dual Certified *9MPT & *9MPV-A2 Models)

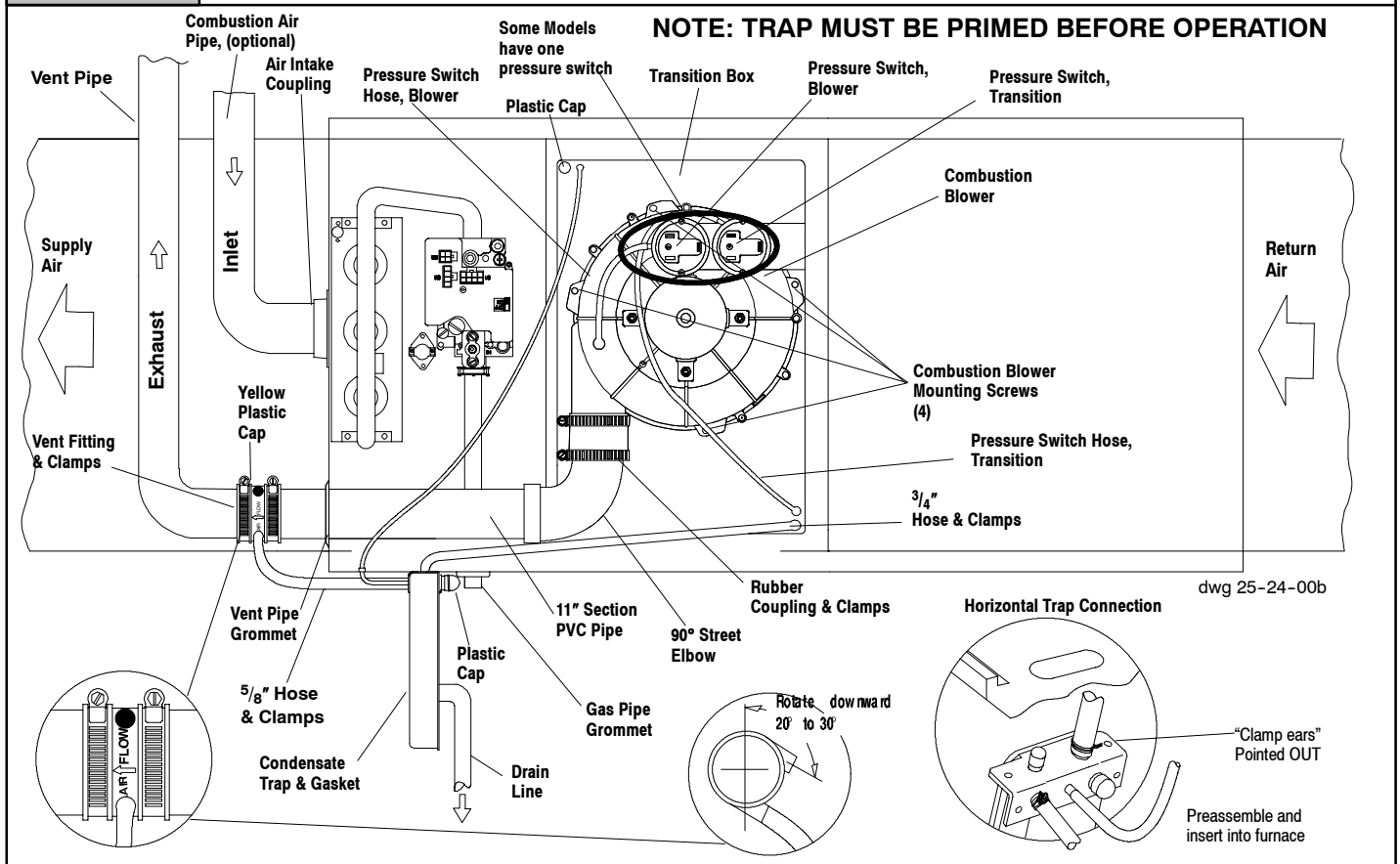

Horizontal Left Installations - (Dual Certified *9MPT & *9MPV-A2 Models) (See Figure 45)

Note: For easier installation of the drain hoses and clamps to the condensate trap, follow the directions outlined below except do not make any clamp connections to any of the drain stubs and hoses until the hose routing and lengths have been determined. Remove the condensate trap and drain hoses from the furnace and secure the drain hoses to the drain stubs on the trap with the hose clamps (position the clamps as shown in **Figure 45**). Install the condensate trap/hose assembly to the furnace casing. Hook one side of the "clamp ears" on the drain stub through the hole in the casing and push the condensate trap into position. Secure with the two screws. Reconnect the drain hoses to the stubs on the vent fitting and the plastic transition and secure with the clamps.

Relocate the plastic cap and clamp on the condensate drain trap from the vertical transition drain stub to the horizontal transition drain stub. Secure the clamps tightly to prevent condensate leakage. Do not change the cap and clamp on the vent drain stub.

Mount the condensate drain trap in a vertical position to the left side of the furnace using the two screws and gasket that are provided. **Note:** The condensate trap will be located under the furnace in a vertical position when the furnace is placed horizontally on the left side. If needed, remove the hole plugs from the furnace side panel and relocate to the open set of holes in the opposite side panel.

NOTE: All gaskets and seals must be in place for sealed combustion applications.

Remove the 90° street elbow and vent fitting from the combustion blower by loosening the clamps on the vent fitting. Connect the 90° street elbow to the combustion blower using the rubber coupling and clamps. Glue the 11" section of PVC pipe to the 90° street elbow after checking the fit up. (Follow the procedures outlined in the *Join-*

ing Pipe and Fittings section of this manual, page 30.) The PVC pipe will extend through the top panel about 1¹/₂". Connect the vent fitting to the end of the 11" section of PVC pipe using the clamp.

NOTE: The vent fitting **MUST** be installed with the airflow marking arrow pointed toward the vent pipe, with the drain stub at a 20 to 30° downward slope.

Plug the upper drain stub on the vent fitting with the yellow plastic cap.

Connect the 5/8" OD rubber hose with the 90° bend to the lower drain stub on the vent fitting and secure with a 5/8" clamp.

Route the hose to the horizontal drain stub on the condensate trap. Cut off excess hoses and discard. Connect the hose to the drain stub on the condensate trap and secure with a 5/8" clamp.

Connect the 3/4" OD rubber hose with the 90° bend to the large drain stub on the condensate trap and secure with a 3/4" clamp.

Route the hose to the drain stub on the bottom of the plastic transition box. Cut off excess hose and discard. Connect the hose to the drain stub on the transition and secure with a 3/4" clamp.

The pressure tap on the condensate trap **MUST** be connected to the unused pressure tap located on the top of the plastic transition box. Remove the plastic caps from the pressure taps on the condensate trap and the plastic transition and connect with the 5/16" OD rubber hose.

NOTE: This will require drilling a 5/16" OD hole in the furnace casing next to the condensate trap.

NOTE: Ensure hoses maintain a downward slope to the condensate trap with no kinking or binding for proper condensate drainage.

Figure 46

Horizontal Right Installations (Dual Certified *9MPT & *9MPV-A2 Models)

NOTE: TRAP MUST BE PRIMED BEFORE OPERATION

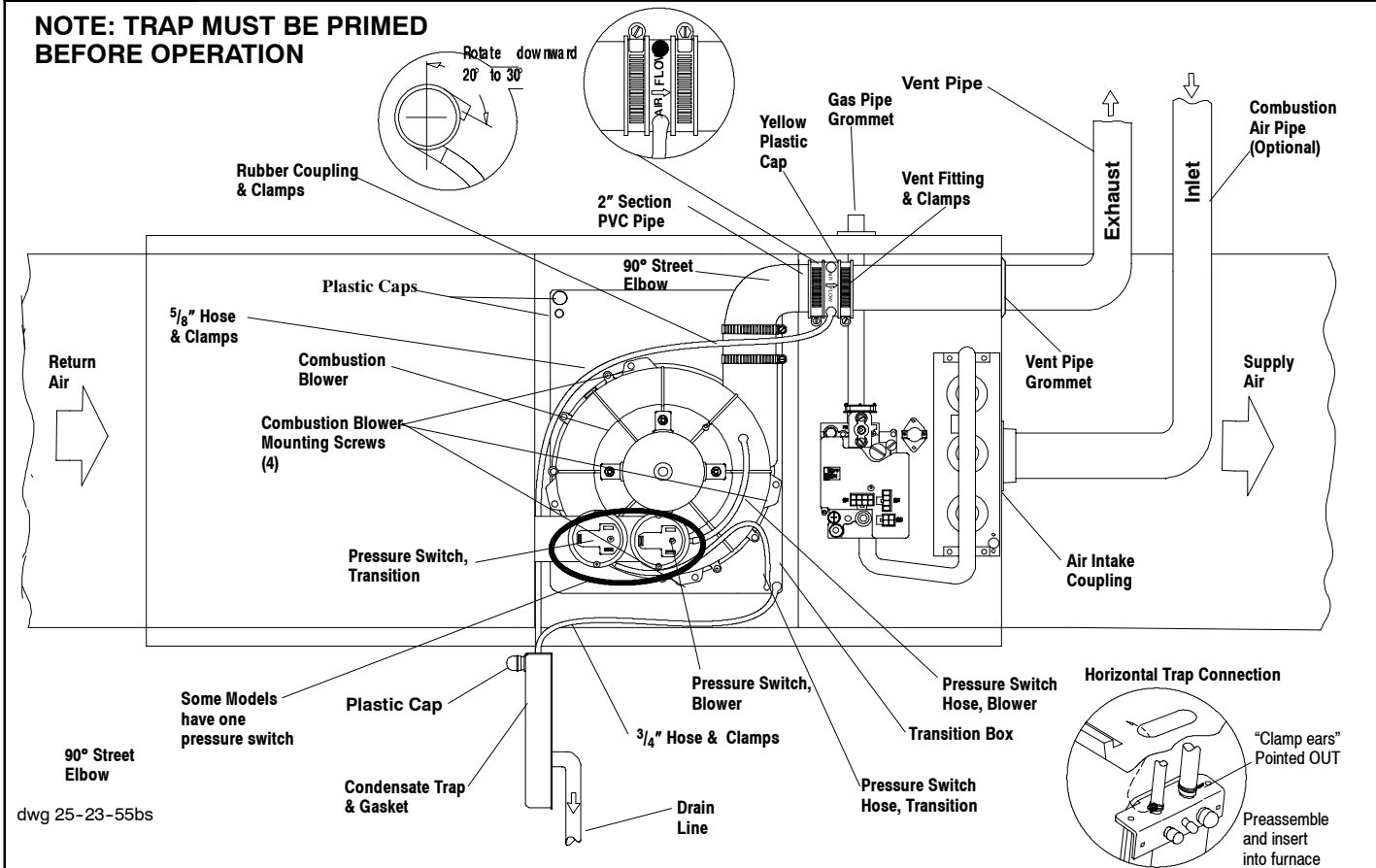

dwg 25-23-55bs

Horizontal Right Installations - (Dual Certified *9MPT & *9MPV) (See Figure 46)

Note: For easier installation of the drain hoses and clamps to the condensate trap, follow the directions outlined below except do not make any clamp connections to any of the drain stubs and hoses until the hose routing and lengths have been determined. Remove the condensate trap and drain hoses from the furnace and secure the drain hoses to the drain stubs on the trap with the hose clamps (position the clamps as shown in **Figure 46**). Install the condensate trap/hose assembly to the furnace casing. Hook one side of the "clamp ears" on the drain stub through the hole in the casing and push the condensate trap into position. Secure with the two screws. Reconnect the drain hoses to the stubs on the vent fitting and the plastic transition and secure with the clamps.

Relocate the plastic caps and clamps on the condensate drain trap from the vertical drain stub to the horizontal drain stubs. Secure the clamps tightly to prevent condensate leakage.

Mount the condensate drain trap in a vertical position to the right side of the furnace using the two screws and gasket that are provided. Note: The condensate trap will be located under the furnace in a vertical position when the furnace is placed horizontally on the right side. If needed, remove the hole plugs from the furnace side panel and relocated to the open set of holes in the opposite side panel.

NOTE: All gaskets and seals must be in place for sealed combustion applications.

Remove the 90° street elbow and vent fitting from the combustion blower by loosening the clamps on the vent fitting. Connect the 90° street elbow to the combustion blower using the rubber coupling and clamps. Cut a 2" section of PVC pipe from the PVC pipe provided with the furnace. Glue the 2" section of PVC pipe to the 90°

street elbow after checking the fit up. (Follow the procedures outlined in the *Joining Pipe and Fittings* section of this manual, page 30.) Connect the vent fitting to the end of the 2" section of PVC pipe using the clamp.

NOTE: The vent fitting **MUST** be installed with the airflow marking arrow pointed toward the vent pipe, with the drain stub at a 20° to 30° downward slope.

Plug the upper drain stub on the vent fitting with the yellow plastic cap.

Remove the pressure switch hose from the upper stub on the plastic transition box.

Relocate the plastic caps on the stubs of the plastic transition box from the lower stubs to the upper stubs and secure tightly with the clamps.

Route the pressure switch hose to the lower stub on the plastic transition box. Cut off excess hose and discard. Connect the pressure switch hose to the lower stub on the plastic transition box. Ensure that the hose is routed above the stub on the transition box so that condensate does not collect in the hose. **NOTE:** Failure to correctly install the pressure switch hose to the transition can adversely affect the safety control operation.

Connect the 3/4" OD rubber hose with the 90° bend to the large drain stub on the condensate trap and secure with a 3/4" clamp.

Route the hose to the drain stub on the bottom of the plastic transition box. Cut off excess hose and discard. Connect the hose to the drain stub on the transition and secure with a 3/4" clamp.

Connect the 5/8" OD rubber hose with the 90° bend to the lower drain stub on the vent fitting and secure with a 5/8" clamp.

Route the hose to the smaller drain stub on the condensate trap. Cut off excess hose and discard. Connect the hose to the drain stub on the trap and secure with a $\frac{5}{8}$ " clamp.

NOTE: Ensure hoses maintain a downward slope to the condensate trap with no kinking or binding for proper condensate drainage.

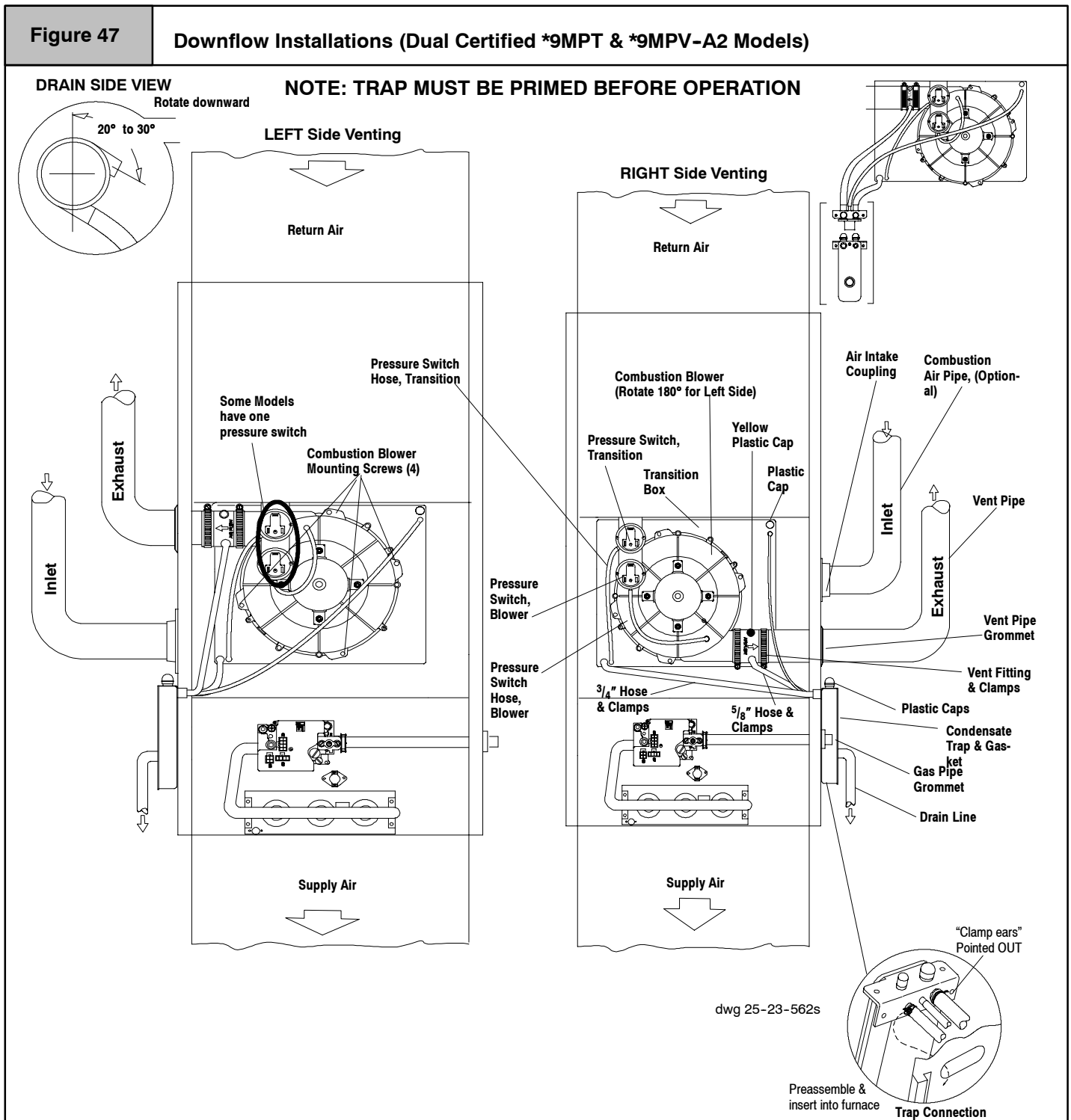

Downflow Installations - (Dual Certified *9MPT & *9MPV Models) (See Figure 47)

Note: For easier installation of the drain hoses and clamps to the condensate trap, follow the directions outlined below except do not make any clamp connections to any of the drain stubs and hoses until the hose routing and lengths have been determined. Remove the condensate trap and drain hoses from the furnace and secure the drain hoses to the drain stubs on the trap with the hose clamps

(position the clamps as shown in **Figure 47**). Install the condensate trap/hose assembly to the furnace casing. Hook one side of the "clamp ears" on the drain stub through the hole in the casing and push the condensate trap into position. Secure with the two screws. Reconnect the drain hoses to the stubs on the vent fitting and the plastic transition and secure with the clamps.

Mount the condensate drain trap in a vertical position to either the right or left side of the furnace using the two screws and gasket that are provided. If needed, remove the hole plugs from the furnace side panel and relocated to the open set of holes in the opposite side panel.

NOTE: All gaskets and seals must be in place for sealed combustion applications.

For both right and left side vent, remove the 90° street elbow from the vent fitting by loosening the clamp on the vent fitting.

Ensure that the vent fitting is securely attached to the combustion blower using the rubber coupling and clamps.

This configuration allows left side venting from the furnace. If the right side venting is required, the combustion blower must be relocated on the plastic transition box. Remove the four(4) screws that

secure the blower to the transition. Rotate the blower 180° and secure with the four(4) screws. Use caution to not over tighten the screws to prevent stripping out of the plastic mounting holes.

NOTE: The vent fitting **MUST** be installed with the airflow marking arrow pointed toward the vent pipe, with the drain stub at a 20° to 30° downward slope.

Plug the upper drain stub on the vent fitting with the yellow plastic cap.

Remove the pressure switch hose from the upper stub on the plastic transition box.

Relocate the plastic caps on the stubs of the plastic transition box from the lower stubs to the upper stubs and secure tightly with the clamps.

28. HEAT EXCHANGER REMOVAL/REPLACEMENT

Figure 48

"Exploded" Parts View - Typical Four Position Furnaces

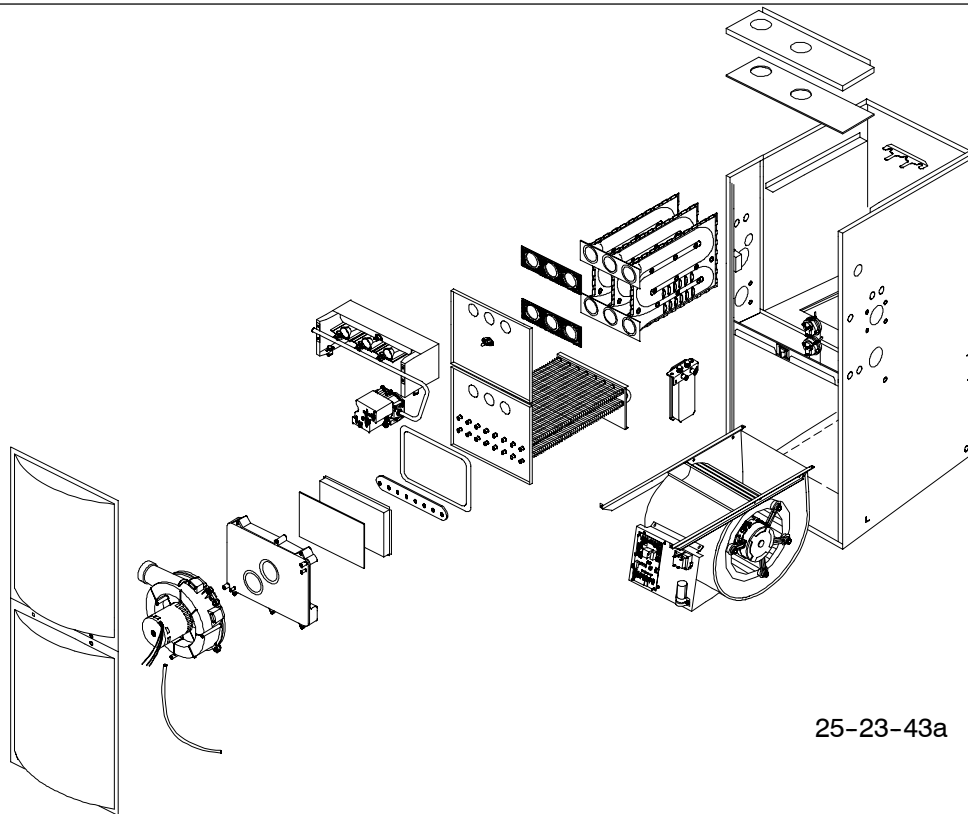

25-23-43a

Secondary Heat Exchanger

1. Turn "OFF" electrical power and gas supply to furnace.
2. Disconnect vent pipe to furnace at flexible coupling.
3. Remove combustion blower.
4. Remove machine screws securing transition drain trap assembly to furnace front partition.
5. Remove the collector box.
6. Loosen the four(4) screws on the manifold or as an alternative the four(4) screws on the manifold bracket.
7. Move the manifold bracket and valve up enough so the secondary heat exchanger will clear the flange on the baffle.
8. Remove machine screws securing secondary heat exchanger inlet flange to lower partition.
9. Remove screws around perimeter of lower partition.
10. Removed screws securing secondary heat exchanger to the supports.
11. Coil can now be removed from furnace.
12. Reverse procedure to reinstall, making sure that any gaskets that have been torn during disassembly are replaced with new ones.

Primary Heat Exchanger

1. Turn "OFF" electrical power and gas supply to furnace.
2. Disconnect vent pipe to furnace at flexible coupling.

3. Disconnect combustion air inlet pipe at top panel if needed.
4. Remove furnace top panel.
5. Disconnect gas piping to furnace at gas valve. Note: Before performing next step, insure that the wiring diagram is available and readable, or tag all wires first.
6. Disconnect tubing and wiring to pressure switch, limit switches, and gas valve.
7. Remove screws securing burner box to front partition.
8. Remove combustion blower.
9. Remove machine screws securing transition assembly to furnace partition.
10. Remove the collector box.
11. Remove machine screws securing secondary heat exchanger inlet flange to lower partition.
12. Remove screws around perimeter of both the upper and lower partitions (leaving the screws across the center of the two panels in place).
13. Primary Heat Exchanger can now be removed with both upper and lower partitions attached.
14. Reverse procedure to reinstall, making sure that any gaskets that have been torn during disassembly are replaced with new ones.
15. After reassembly, turn the gas supply on, and check for leaks. All leaks must be repaired immediately.
16. Perform an operational check of the furnace.

HONEYWELL SV9541Q “SMART VALVE” Sequence of Operation

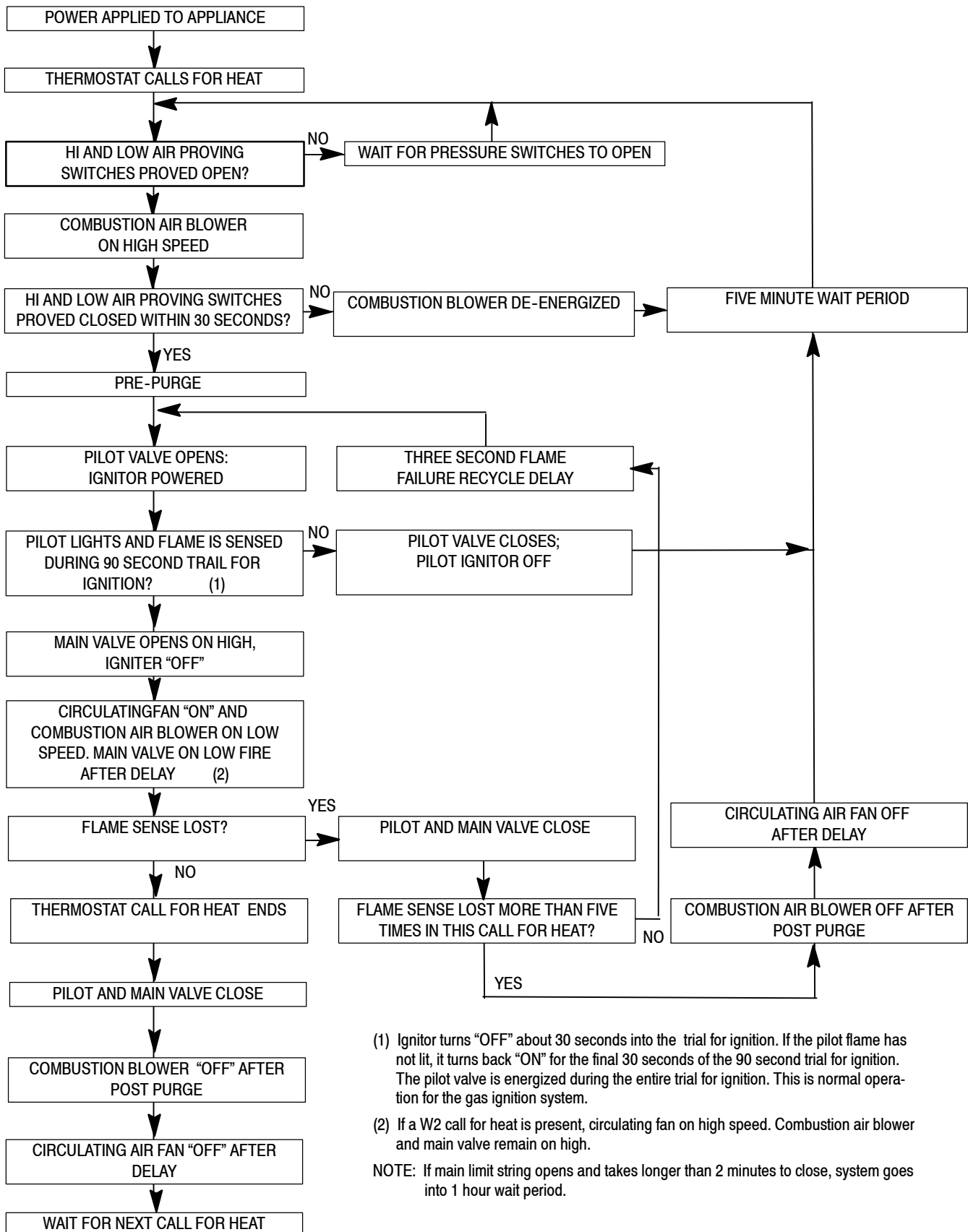

(1) Ignitor turns “OFF” about 30 seconds into the trial for ignition. If the pilot flame has not lit, it turns back “ON” for the final 30 seconds of the 90 second trial for ignition. The pilot valve is energized during the entire trial for ignition. This is normal operation for the gas ignition system.

(2) If a W2 call for heat is present, circulating fan on high speed. Combustion air blower and main valve remain on high.

NOTE: If main limit string opens and takes longer than 2 minutes to close, system goes into 1 hour wait period.

HONEYWELL SV9541Q “SMART VALVE” Trouble shooting

The 6 + X designation indicates a combination of flash codes: 6 flashes shows the control is in soft lockout, followed by X flashes to

indicate the reason the control went into soft lockout. Last status code indicates repair to address first

LED STATUS	INDICATES	CHECK/REPAIR
Off	No power to system control.	Line voltage input at L1 and Neutral connectors on ST9162A Fan Timer. Low voltage (24V) power at 24 VAC and COM terminals on ST9162A System wiring harness is in good condition and securely connected.
Heartbeat Bright – Dim	Normal indication whenever the system is powered, unless some abnormal event has occurred.	Not Applicable – Normal Operation (stand by or call for heat)
2 Flashes	Low pressure switch closed when it should be open (i.e. when call for heat begins). (Combustion blower is not energized until pressure switches opens)	Pressure switch stuck closed (system will wait for pressure switch to open). Pressure switch miswired or jumpered.
3 Flashes	Low pressure switch, open when it should be closed (i.e. longer than 30 seconds after combustion blower/ inducer is energized). System goes into 5-minute delay period, with combustion blower/inducer off. At end of the 5-minute delay, another cycle will begin.	Ignition system control switch must be in the ON position. Pressure switch operation, tubing, and wiring. Restrictions in furnace air intake or vent piping.
4 Flashes	Main Limit or Roll Out Switch is open. Combustion blower is energized, Circulating blower is energized heat speed.	Main limit switch. Manual reset burner rollout switch. Limit and rollout switch wiring is in good condition and securely connected.
5 Flashes	Flame signal sensed out of proper sequence. Combustion blower is energized, Circulating blower is energized heat speed after the “ON” delay.	Flame at pilot burner.
6 Flashes + 1 Flash	Soft Lockout. Failed to light pilot during 90 sec. trial for ignition Combustion air blower is de-energized, Circulating blower is de-energized after the “OFF” delay. After 5-minute delay time, control system will reset and initiate a new ignition sequence,	Gas supply off or pressure too low or high for appliance to operate. Damaged or broken HIS element Line voltage HOT lead wire not connected to L1 terminal on ST9162A. Furnace not properly earth grounded. Flame sense rod contaminated or in incorrect position. Pilot burner located in incorrect position. Pilot burner lead wires are in good condition and properly connected. Pressure switches operation, tubing, and wiring.
6 Flashes + 2 Flashes	Soft Lockout. Last failure was Flame Sense lost during run. Maximum recycle count exceeded Combustion air blower is de-energized, Circulating blower is de-energized after the “OFF” delay. After 5-minute delay time, control system will reset and initiate a new ignition sequence,	Gas supply off or pressure too low or high for appliance to operate. Line voltage HOT lead wire not connected to L1 terminal on ST9162A. Furnace not properly earth grounded. Flame sense rod contaminated or in incorrect position. Pilot burner located in incorrect position. Pilot burner lead wires are in good condition and properly connected. Cycling, pressure switch Condensate drain blocked Pressure switches operation, tubing, and wiring.

HONEYWELL SV9541Q “SMART VALVE” Trouble shooting continued

LED STATUS	INDICATES	CHECK/REPAIR
6 Flashes + 3 Flashes	<p>Soft Lockout.</p> <p>Last failure was pressure switch</p> <p>Maximum recycle count exceeded</p> <p>Combustion air blower is de-energized, Circulating blower is de-energized after the “OFF” delay.</p> <p>After 5-minute delay time, control system will reset and initiate a new ignition sequence,</p>	<p>Ignition system control switch must be in the ON position.</p> <p>Pressure switches operation, tubing, and wiring.</p> <p>Restrictions in furnace air intake or vent piping.</p> <p>High winds blowing against vent.</p>
6 Flashes + 4 Flashes	<p>Soft Lockout.</p> <p>Last failure was limit circuit opened during run.</p> <p>Combustion air blower is de-energized, Circulating blower is de-energized after the “OFF” delay.</p> <p>After 5-minute delay time, control system will reset and initiate a new ignition sequence,</p>	<p>Main limit switch.</p> <p>Limit and rollout switch wiring is in good condition and securely connected.</p> <p>Restriction in duct work.</p> <p>Dirty filter</p>
7 Flashes	<p>Soft Lockout.</p> <p>Blower failure (typical)</p> <p>Limit trip took longer than 2 minutes to reset.</p> <p>System will start a new ignition sequence after 1 hour, if call for heat still present.</p>	<p>Dead blower.</p> <p>Blocked duct work.</p>
8 Flashes	<p>High Pressure closed when should be open. (i.e., when call for heat begins).</p> <p>(Combustion blower is not energized until pressure switches open)</p>	<p>Pressure switches stuck closed (system will wait for pressure switch to open).</p> <p>Pressure switch miswired or jumpered.</p>
9 Flashes	<p>High Pressure open when should be closed. (i.e., longer than 30 seconds after combustion/inducer is energized).</p> <p>System goes into a 5 minute delay period with combustion blower/inducer “OFF”. At end of the 5 minute delay another cycle begins.</p>	<p>Ignition system control switch must be in the “ON” position.</p> <p>Pressure switch operation, tubing and wiring.</p> <p>Restrictions in furnace air intake or vent piping.</p>

SV9541Q ELECTRICAL VARIATION 2-STAGE

Connector (Pin #)	Description	Voltage Signal	When Signal is Present
Neutrals (5- $\frac{1}{4}$ " QC's)	Neutral	0 VAC (Neutral and earth ground should be at the same potential)	Always present
120 VAC Line, XFMR, DC MTR (3- $\frac{1}{4}$ " QC's)	Line Voltage	115 VAC	Present when blower door interlock switch is closed.
HEAT LOW ($\frac{1}{4}$ " QC's)	Fan power	*115 VAC	Present when Low Heat fan speed is on (G request, Low Heat (W1) mode after Heat Fan On Delay, Heat Fan Off Delay)
HEAT HIGH ($\frac{1}{4}$ " QC's)	Fan power	*115 VAC	Present when High Heat fan speed is on (High Heat (W1 & W2) mode, Open Limit mode).
COOL ($\frac{1}{4}$ " QC's)	Fan power	*115 VAC	Present when Cool fan speed is on (Cool (Y) mode).
EAC ($\frac{1}{4}$ " QC's)	Electronic Air-Cleaner power	115 VAC	Present when High Heat, Low Heat or Cool fan speed is on.
CONSTANT FAN ($\frac{1}{4}$ " QC's)	Continuous Fan power	*115 VAC	Present when other fan speeds are on.
IND IN ($\frac{1}{4}$ " QC's)	Inducer motor power from Smart Valve™	115 VAC	Present when Induced draft blower motor is on (Heat modes, Open Limit mode).
IND LOW ($\frac{3}{16}$ " QC's)	Inducer motor power from Smart Valve™	115 VAC	Present when Induced draft blower motor is on (Heat modes, Open Limit mode).
HUM ($\frac{1}{4}$ " QC's)	Humidifier power	115 VAC	Present when the High Heat or Low Heat fan speeds are on.
P1 (pin 1)	Neutral	0 VAC	Always present
P1 (pin 2)	High Fire solenoid supply (connects to one side of high pressure switch)	24 VDC (low fire) 16VDC (high fire)	Voltage is always present when 24 VAC transformer is powered. The signal is actually $\frac{1}{2}$ wave rectified AC riding on top of DC voltage. The DC voltage readings given are approximate when measured with a Fluke 79 digital multimeter (or equivalent). To achieve high fire (energize the high fire solenoid), the high pressure switch must be closed and the ST9162 fan board must turn on a transistor.
P1 (pin 3)	24 VAC	24 VAC	Present when the door interlock switch is closed.
P1 (pin 4)	Line Voltage	115 VAC	Present when the door interlock switch is closed.
P1 (pin 5)	Date Line	Non-periodic $\frac{1}{2}$ wave rectified AC (measures as an unstable AC voltage bouncing between 12 VAC and 16 VAC)	Present when the door interlock switch is closed.
P1 (pin 6)	R	24 VAC	Present when the door interlock switch is closed.
P1 (pin 7)	Not connected	No signal	This pin is not used.
P1 (pin 8)	High Fire solenoid return line	$\frac{1}{2}$ wave rectified AC	Present when the door interlock switch is closed. This voltage increases when the high fire solenoid circuit is energized.
P1 (pin 9)	C (xfmr common)	0 VAC	Always present
P2	DC motor control signals	See memo on DC motor signals	See memo on DC motor signals.
C1 (pin 1)	Limit return	$\frac{1}{2}$ wave rectified AC	Present when the door interlock switch is closed. This voltage decreases when a limit switch is open.
C1 (pin 2)	Low Pressure Switch supply	$\frac{1}{2}$ wave rectified AC	Present when the door interlock switch is closed. This signal is the same as the C1 (pin 1)
C1 (pin 3)	Low Pressure Switch return	$\frac{1}{2}$ wave rectified AC	Present when the door interlock switch is closed. This AC voltage decreases when the Low Pressure Switch closes.

* With a motor tap connected, voltage appears at "unpowered" fan terminals whenever the motor is running due to feedback through the motor windings.

** Voltage appears on the "unpowered" inducer terminal whenever the inducer motor is running due to feedback through the motor windings.

NOTE1: Using a Fluke 79 digital Multi-Meter (DMM), $\frac{1}{2}$ wave rectified AC voltage typically measures about 14 VAC. The Fluke 79 is not a "true" RMS meter.

**SV9541Q ELECTRICAL VARIATION
2-STAGE Con't**

Connector (Pin #)	Description	Voltage Signal	When Signal is Present
C1 (pin 4)	Data Line	Non-periodic $\frac{1}{2}$ wave rectified AC	Present when the door interlock switch is closed. Same signal as P1 (pin 5).
C1 (pin 5)	Limit Supply	$\frac{1}{2}$ wave rectified AC	Present when the 24 VAC transformer is powered.
C1 (pin 6)	C (xfmr common)	0 VAC	Always present
C1 (pin 7)	R	24 VAC	Present when the door interlock switch is closed.
C1 (pin 8)	24 VAC	24 VAC	Present when the door interlock switch is closed.
C2 (pin 1)	HSI return	24 VAC (with igniter present)	Present when HSI is not turned on. When HSI is on, this signal is 0 VAC to 10 VAC depending on input line voltage potential.
C2 (pin 2)	HSI supply	24 VAC	Present when the door interlock switch is closed.
C2 (pin 3)	Not connected	0 VAC	Not connected
C2 (pin 4)	Flame sense	>80 VAC	Present when the door interlock switch is closed.
C3 (pin 1)	Inducer supply	115 VAC	Present when the inducer draft blower motor is on (Heat modes, Open Limit mode).
C3 (pin 2)	L1	115 VAC	Present when the door interlock switch is closed.
C3 (pin 3)	Inducer return	0 VAC	Always present (neutral connection).
C3 (pin 4)	L2 (neutral)	0 VAC	Always present

* With a motor tap connected, voltage appears at "unpowered" fan terminals whenever the motor is running due to feedback through the motor windings.

** Voltage appears on the "unpowered" inducer terminal whenever the in-

ducer motor is running due to feedback through the motor windings.

NOTE1: Using a Fluke 79 digital Multi-Meter (DMM), $\frac{1}{2}$ wave rectified AC voltage typically measures about 14 VAC. The Fluke 79 is not a "true" RMS meter.

TECHNICAL SERVICE DATA *9MPV (A1 & A2)

Specifications									
	*9MPV050F12A		*9MPV075F12A		*9MPV100J20A		*9MPV125L20A		
General									
Gas Type	Nat	L.P.	Nat	L.P.	Nat	L.P.	Nat	L.P.	
Transformer Size (VA)	40								
T'stat Heat Anticipator	.10								
Input (Btuh) Std/Alt. Hi Fire									
Lo Fire	50,000		75,000		100,000		125,000		
Output (Btuh) Std/Alt. Hi Fire	35,000		53,000		70,000		87,500		
Lo Fire	46,000		69,000		92,000		115,000		
Temp. Rise (°F) Hi Fire	32,200		48,800		64,400		80,500		
Lo Fire	35-65		40-70		40-70		40-70		
	35-65		40-70		40-70		40-70		
Electrical (Volts/Hz/FLA)	115/60/9.8		115/60/8.9		115/60/9.0		115/60/11.2		
Gas & Ignition									
Gas Type	Nat.	L.P.	Nat.	L.P.	Nat.	L.P.	Nat.	L.P.	
Std. Main Orifices (No/Size)	2/42	2/54	3/42	3/54	4/42	4/54	5/42	5/54	
Gas Valve Honeywell	SV 9541	SV 9541	SV 9541	SV 9541	SV 9541	SV 9541	SV 9541	SV 9541	
Regulation Type	SNAP	SNAP	SNAP	SNAP	SNAP	SNAP	SNAP	SNAP	
Manifold Press. Hi Fire (" WC)	3.5	10.0	3.5	10.0	3.5	10.0	3.5	10.0	
Lo Fire (" WC)	1.7	4.9	1.7	4.9	1.7	4.9	1.7	4.9	
Pilot Orifice Size	.018	.011	.018	.011	.018	.011	.018	.011	
Ignition Type/Series	HW HSP								
Combustion									
Flue Outlet Size (Inches)	2		2		3		3		
Std. Outlet Temp (° F)	<140		<140		<140		<140		
Comb. Blower (MFD/Volts)	4/370		4/370		4/370		4/370		
@ Blower / @ Transition Box (Hi Fire)									
Std. Pressures (" of WC)									
5' No Elbows	-1.80 / -2.60		-1.80 / -2.60		-1.80 / -2.60		-1.80 / -2.60		
40' +5-90° DWV Elbows	-1.30 / -2.30		-1.30 / -2.30		-1.70 / -2.50		-1.70 / -2.50		
@ Blower / @ Transition Box (Lo Fire)									
Std. Pressures (" of WC)									
5' No Elbows	-1.20 / -1.90		-1.20 / -1.90		-1.20 / -1.90		-1.30 / -2.30		
40' +5-90° DWV Elbows	-1.00 / -1.80		-1.00 / -1.80		-1.00 / -1.80		-1.20 / -2.20		
Limits & Controls									
Rollout Switch (°F)	300		300		300		300		
Limit Control Setting (°F)	260		210		240		190		
Fan Control (Type)	HW ST9162A								
Fan Control On	30/60								
(Timed-secs) Off	60,100,140,180								
Std. Pressure Sw. (Part No)	1013515		1013515		1013515		1013166		
Blower Switch Pressure (Close)	0.95		0.95		0.95		1.30		
Blower Switch Pressure (Open)	0.80		0.80		0.80		1.10		
Transition Switch Pressure (Close)	1.70		1.70		1.70		1.80		
Transition Switch Pressure (Open)	1.50		1.50		1.50		1.60		
High Altitude Pressure Sw. (Part No)	1013165		1013165		1013165		1013157		
Blower Switch Pressure (Close)	0.70		0.70		0.70		0.85		
Blower Switch Pressure (Open)	0.55		0.55		0.55		0.70		
Transition Switch Pressure (Close)	1.40		1.40		1.40		1.70		
Transition Switch Pressure (Open)	1.20		1.20		1.20		1.50		
Blower Data									
Type & Size	11-8		11-10		11-10		11-10		
Motor Amps/Rpm	9.8/1050		8.9/1080		11.2/1150		11.2/1150		
Motor Type/H.p.	DC/1/2		DC/1		DC/1		DC/1		
Filter Type	16x25x1		16x25x1		16x25x1		16x25x1 (2)		
Min. Cool Cap. (Tons)	1.5		1.5		2		2		
Max. Cool Cap. (Tons)	3		3		5		5		
Gas Conversion Kits All Models									
Nat to LP	*1011789								
LP to Nat	*1011787								
*Order from Service Parts									

Circulation Air Blower Data - *9MPV(A1 & A2)

Heating, Cooling & Continuous Airflow Settings

Continuous Blower (CFM) @ 0.10" Static

Switch Settings		Furnace Model			
#1	#2	50K	75K	100K	125K
0*	0*	540	540	700	703
0	1	660	660	860	821
1	0	780	780	1020	1000
1	1	900	900	1180	1160

*Factory Setting

Hi Heat Air Temperature Adjustment (° F)**

Switch Settings			Furnace Model			
#3	#4	#5	50K	75K	100K	125K
0**	0**	0**	0	0	0	0
0	0	1	3	2	3	2
0	1	0	6	4	5	6
0	1	1	14	6	9	11
1	0	0	17	11	13	13
1	0	1	-8	-4	-4	-5
1	1	0	-13	-4	-7	-5
1	1	1	-17	-4	-9	-5

*Factory setting

**Approximate air temperature change from factory setting @ 0.20" static on high heat).

Lo Heat Air Temperature Adjustment (° F)**

Switch Settings			Furnace Model			
#3	#4	#5	50K	75K	100K	125K
0**	0**	0**	0	0	0	0
0	0	1	1	1	1	6
0	1	0	4	2	2	8
0	1	1	7	3	5	12
1	0	0	11	6	8	16
1	0	1	-7	-4	-5	-1
1	1	0	-11	-6	-9	-4
1	1	1	-15	-9	-11	-7

*Factory setting

**Approximate air temperature change from factory setting @ 0.20" static on high heat).

Cooling (CFM) @ 0.50" Static

Switch Settings			Furnace Model			
#6	#7	#8	50K	75K	100K	125K
0*	0*	0*	1170	1395	2095	2059
0	0	1	1098	1197	1875	1859
0	1	0	991	1096	1642	1700
0	1	1	894	1000	1489	1621
1	0	0	807	907	1255	1410
1	0	1	697	799	1013	1191
1	1	0	621	650	830	986
1	1	1	556	543	750	800

*Factory setting

Blower Motor Settings

CONTINUOUS
CFM SELECT

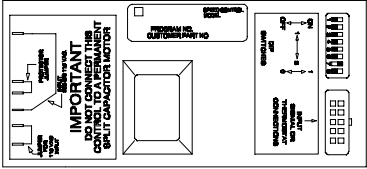

HEATING
CFM SELECT

COOLING
CFM SELECT

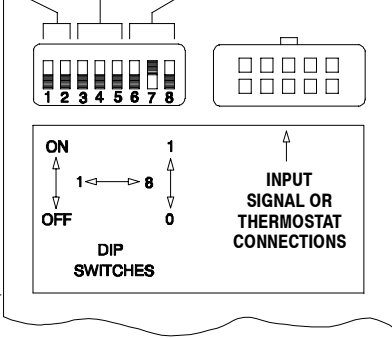

DIP SWITCHES

0 1 0

***EXAMPLE**
Cooling Airflows Switches 6, 7 & 8:

000 3.5 Ton
001 3.0 Ton
010 2.5 Ton
011 2.0 Ton

***See "Technical Support Manual" for correct airflow rates.**

25-23-10

Circulation Air Blower Data - *9MPV(A1 & A2)

Heating, Cooling & Continuous Airflow Settings

Figure 1

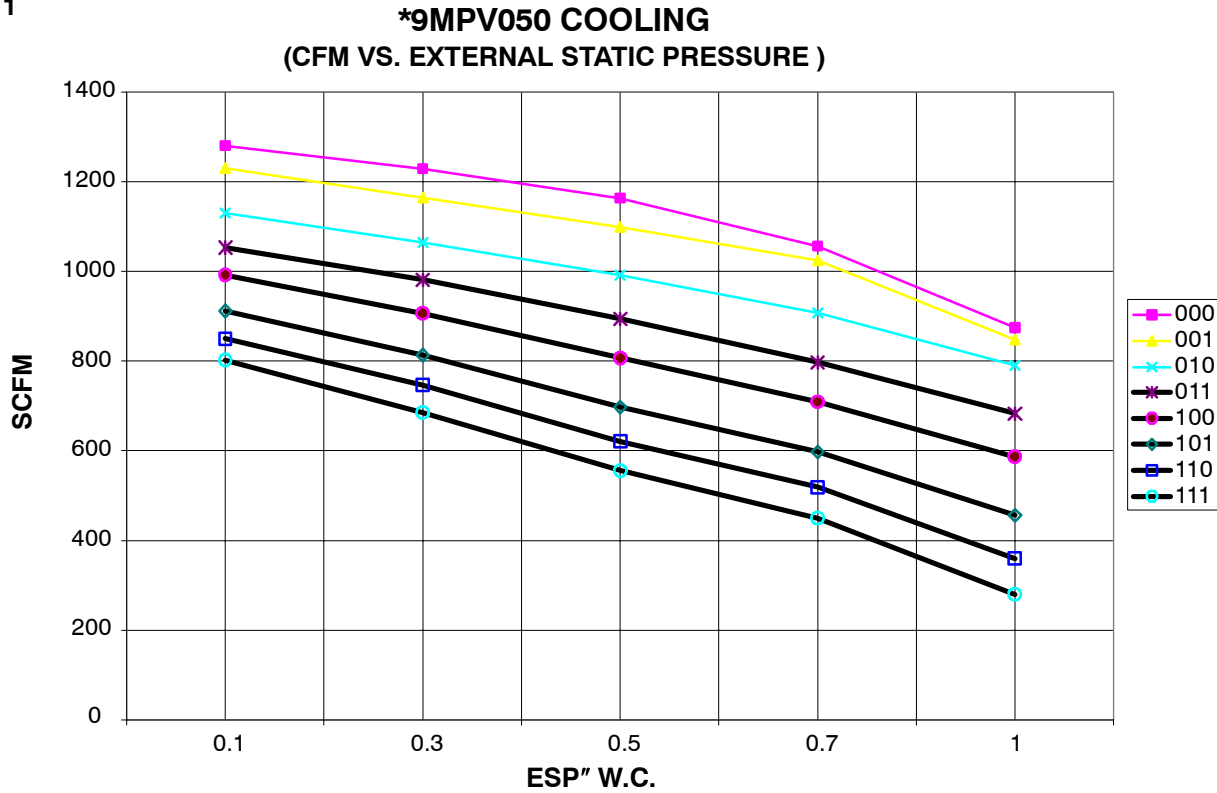
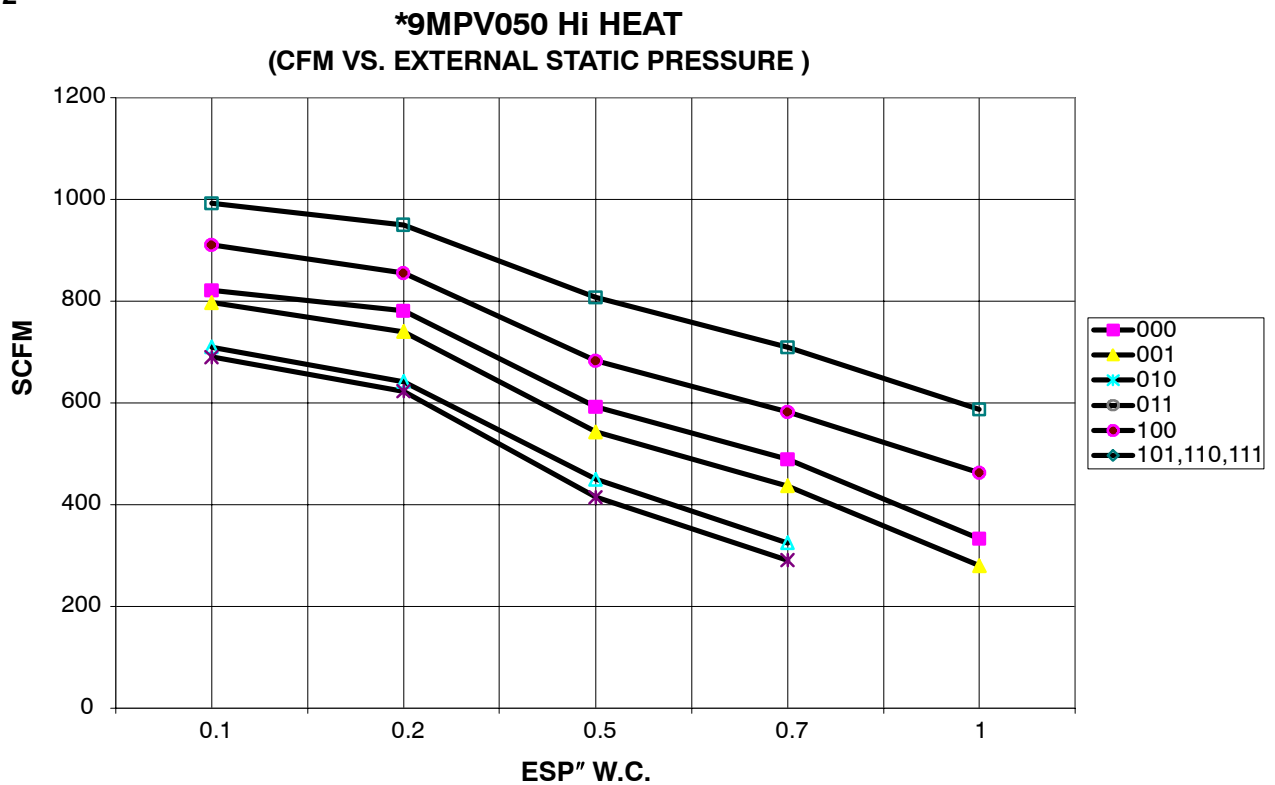

Figure 2



Circulation Air Blower Data - *9MPV(A1 & A2)

Heating, Cooling & Continuous Airflow Settings

Figure 3

***9MPV050 Lo HEAT**
(CFM VS. EXTERNAL STATIC PRESSURE)

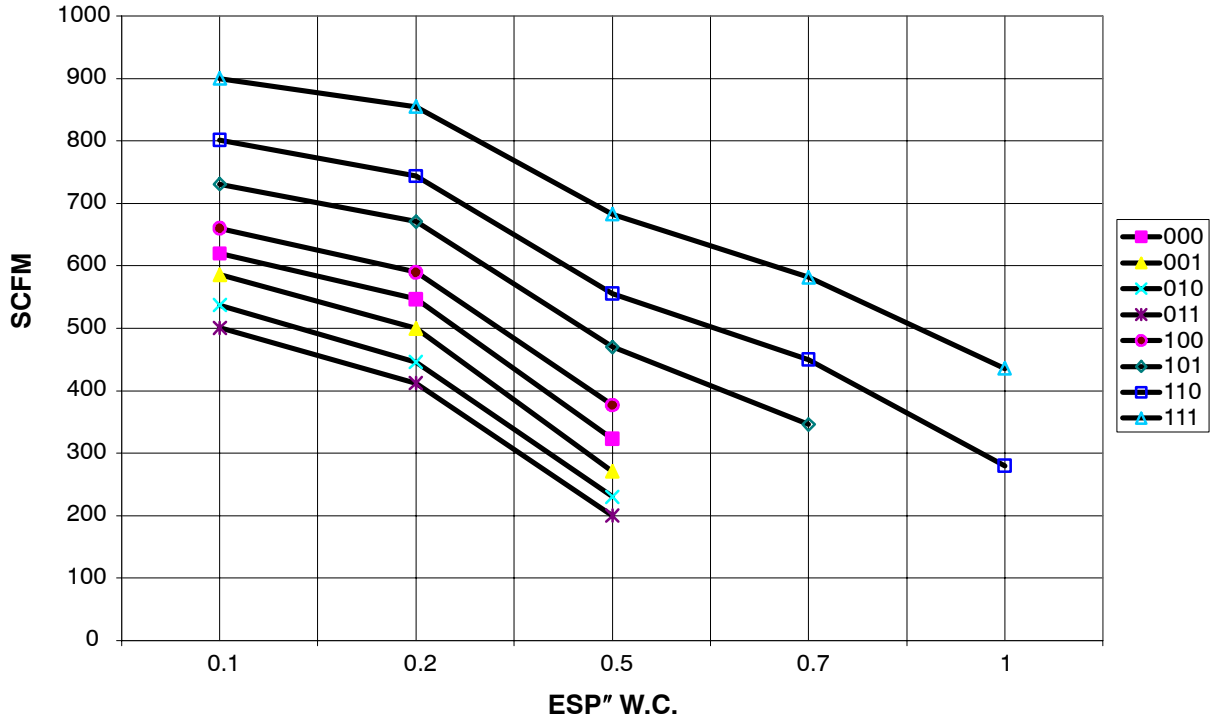
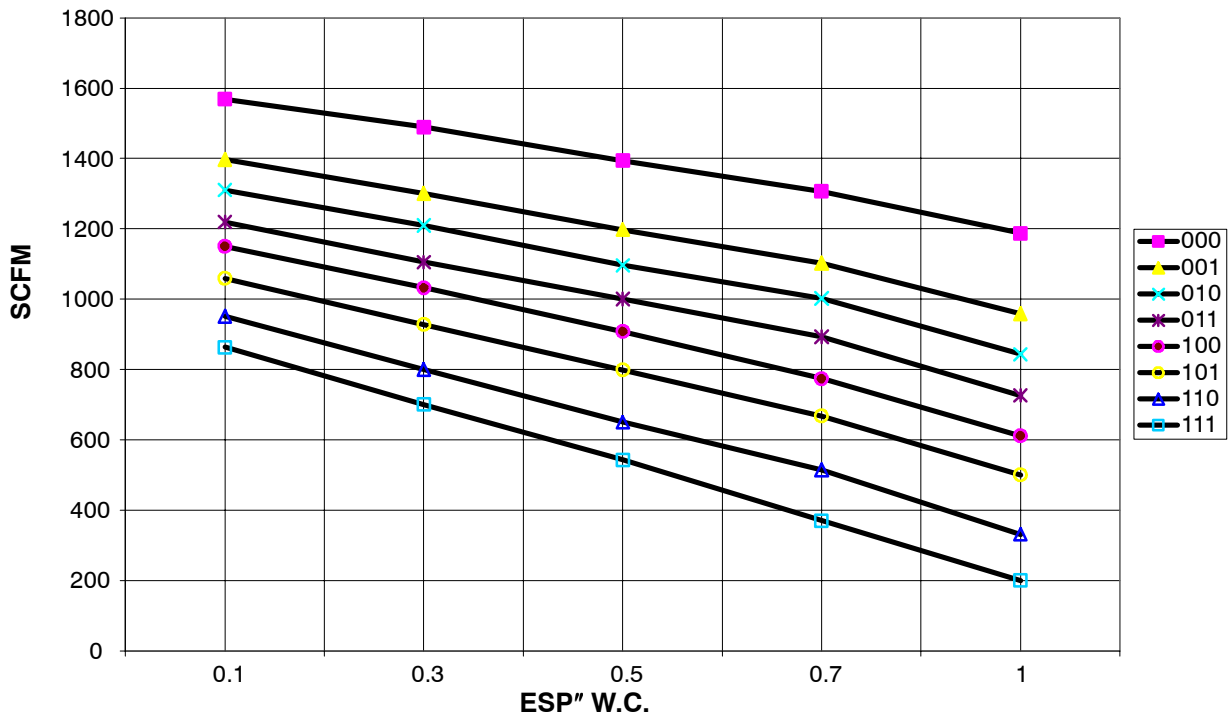

Figure 4

***9MPV075 COOLING**
(CFM VS. EXTERNAL STATIC PRESSURE)



Circulation Air Blower Data - *9MPV(A1 & A2)

Heating, Cooling & Continuous Airflow Settings

Figure 5

***9MPV075 Hi HEAT**
(CFM VS. EXTERNAL STATIC PRESSURE)

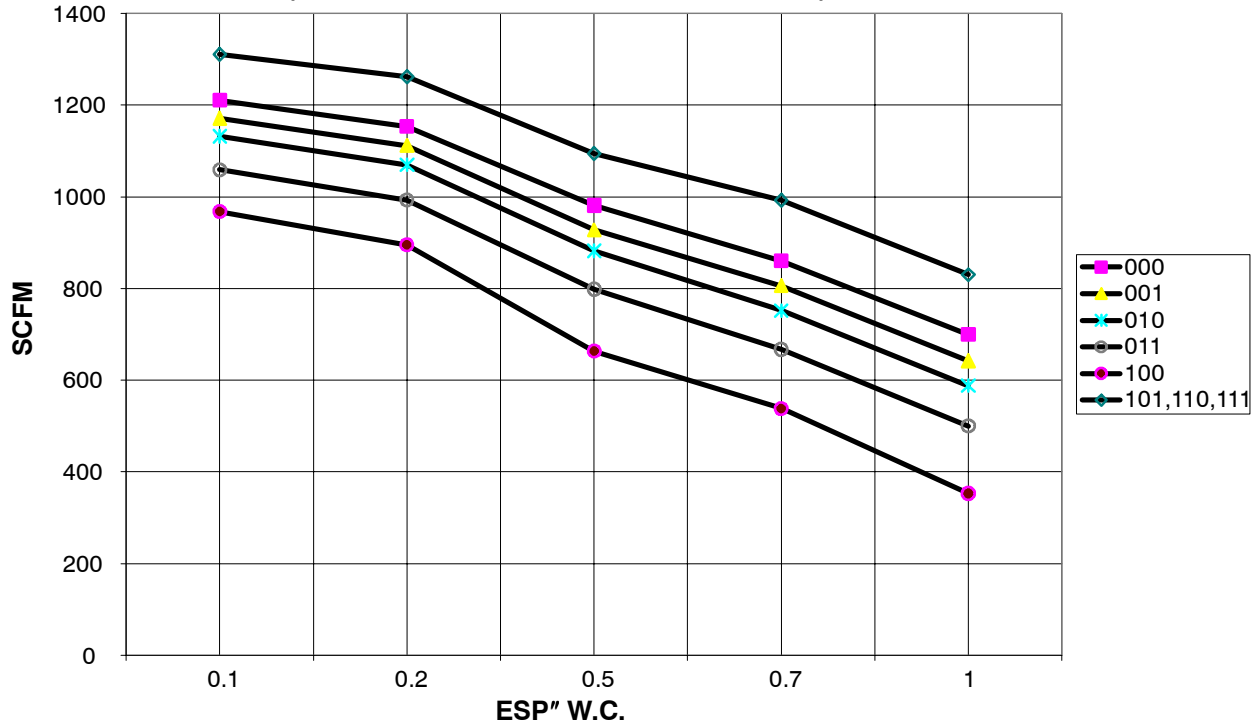
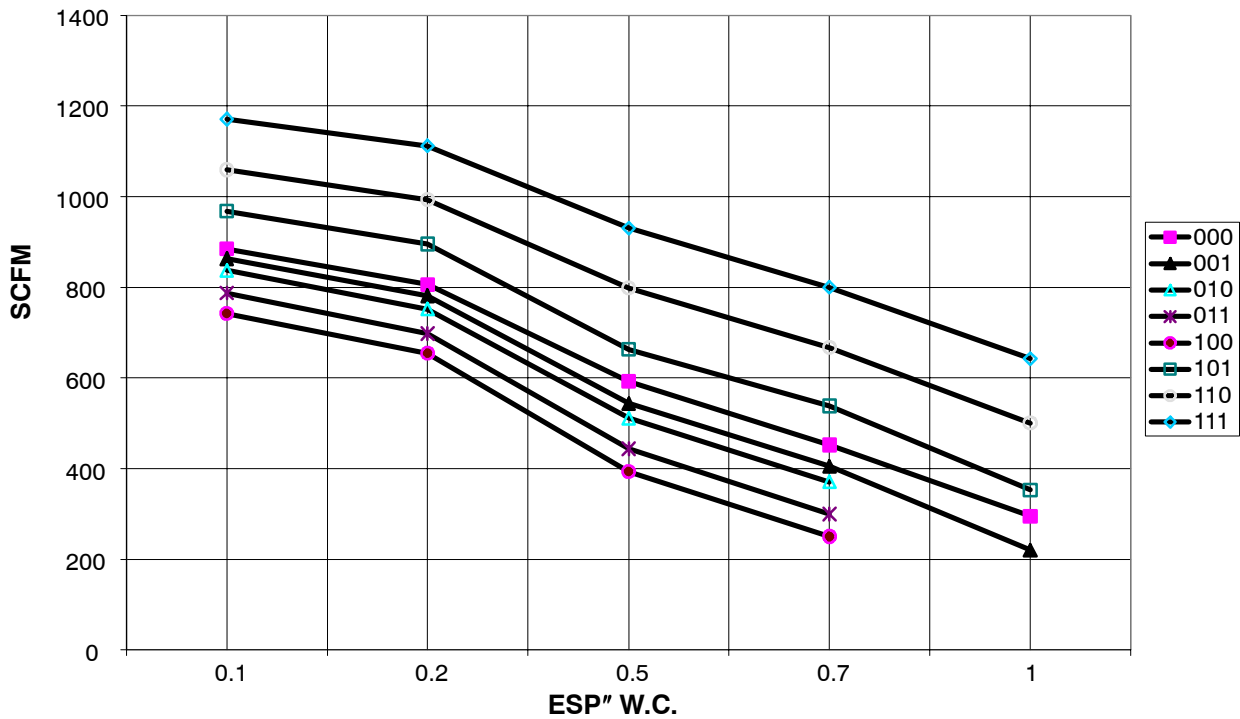

Figure 6

***9MPV075 Lo HEAT**
(CFM VS. EXTERNAL STATIC PRESSURE)



Circulation Air Blower Data - *9MPV(A1 & A2)

Heating, Cooling & Continuous Airflow Settings

Figure 7

***9MPV100 COOLING**
(CFM VS. EXTERNAL STATIC PRESSURE)

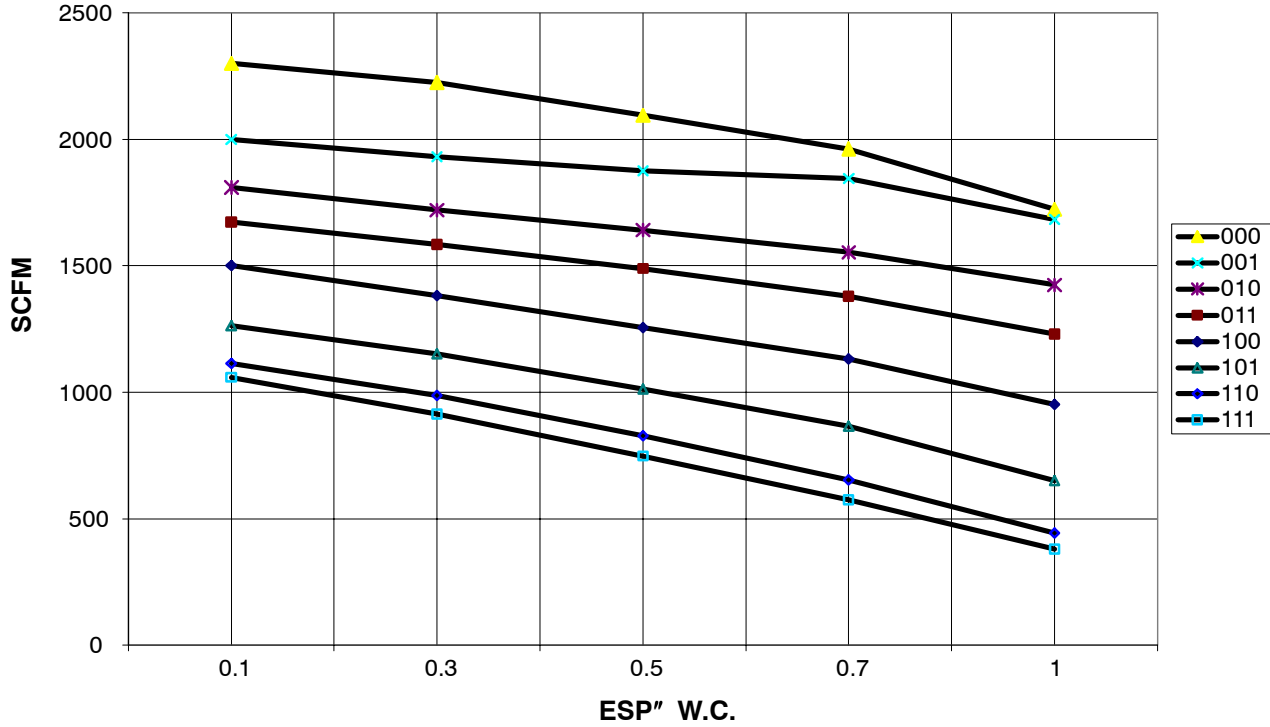
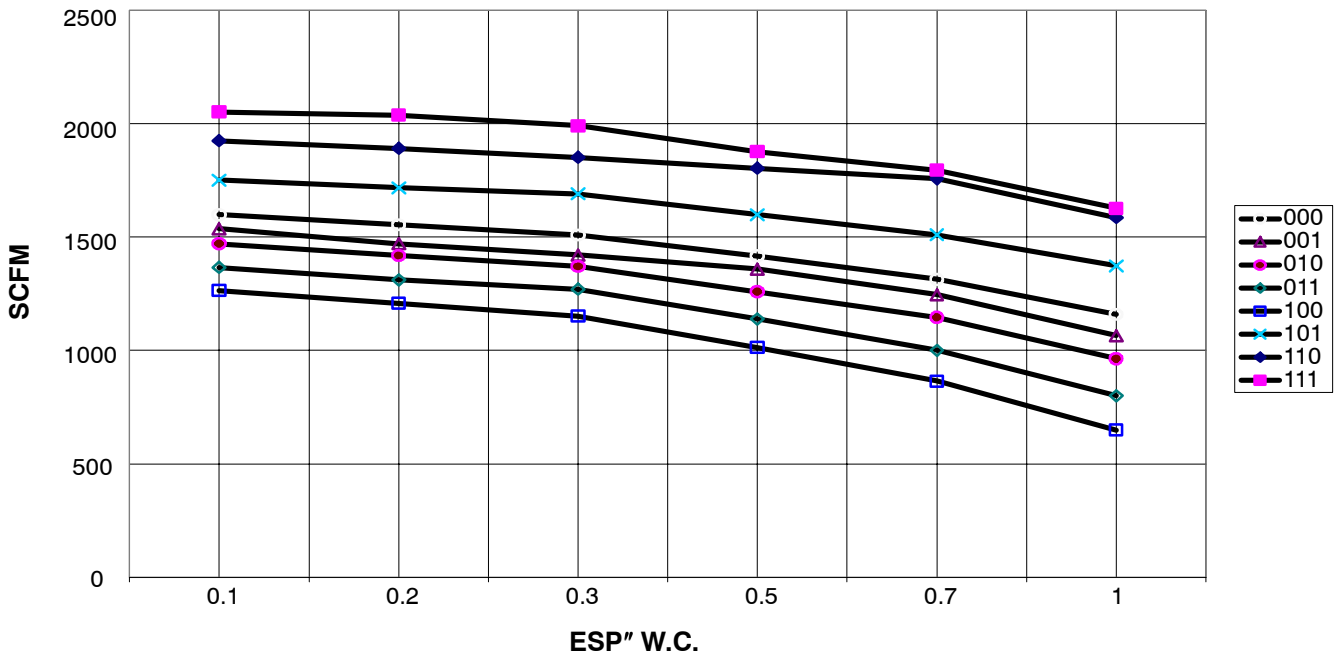

Figure 8

***9MPV100 Hi HEAT**
(CFM VS. EXTERNAL STATIC PRESSURE)



Circulation Air Blower Data - *9MPV(A1 & A2)

Heating, Cooling & Continuous Airflow Settings

Figure 9

***9MPV100 Lo HEAT**
(CFM VS. EXTERNAL STATIC PRESSURE)

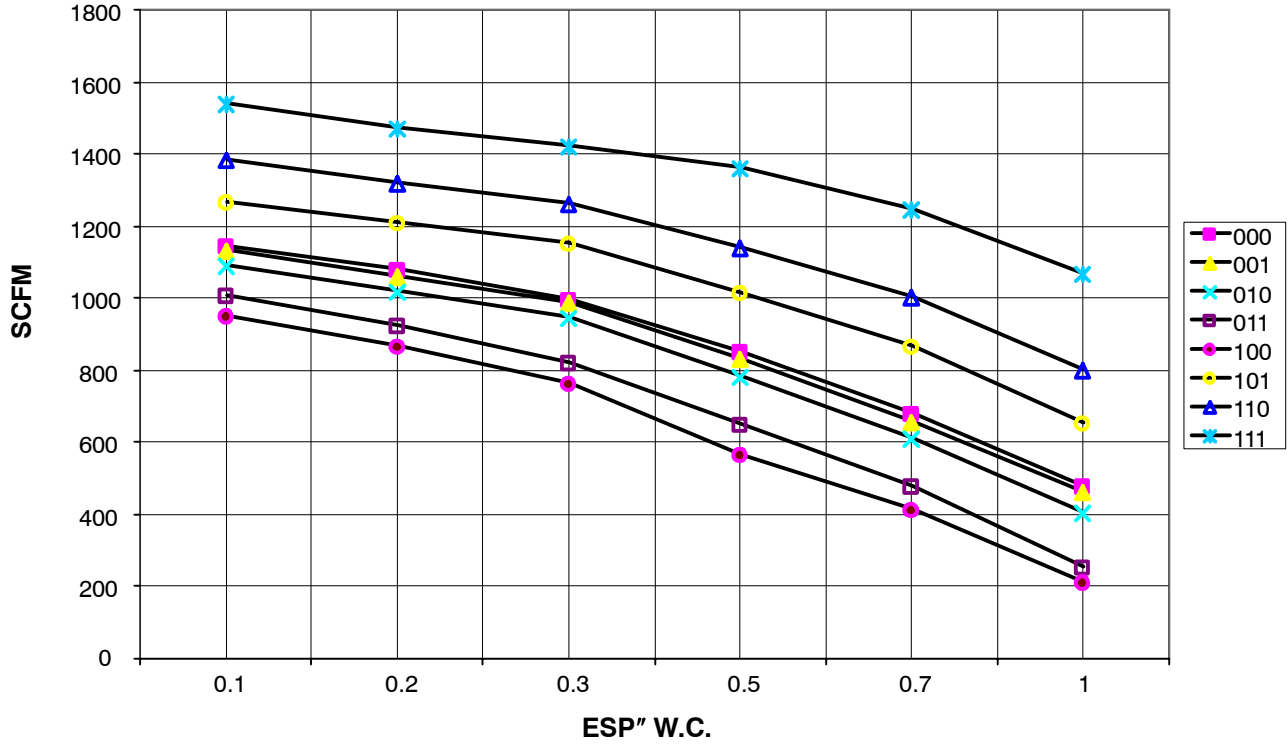
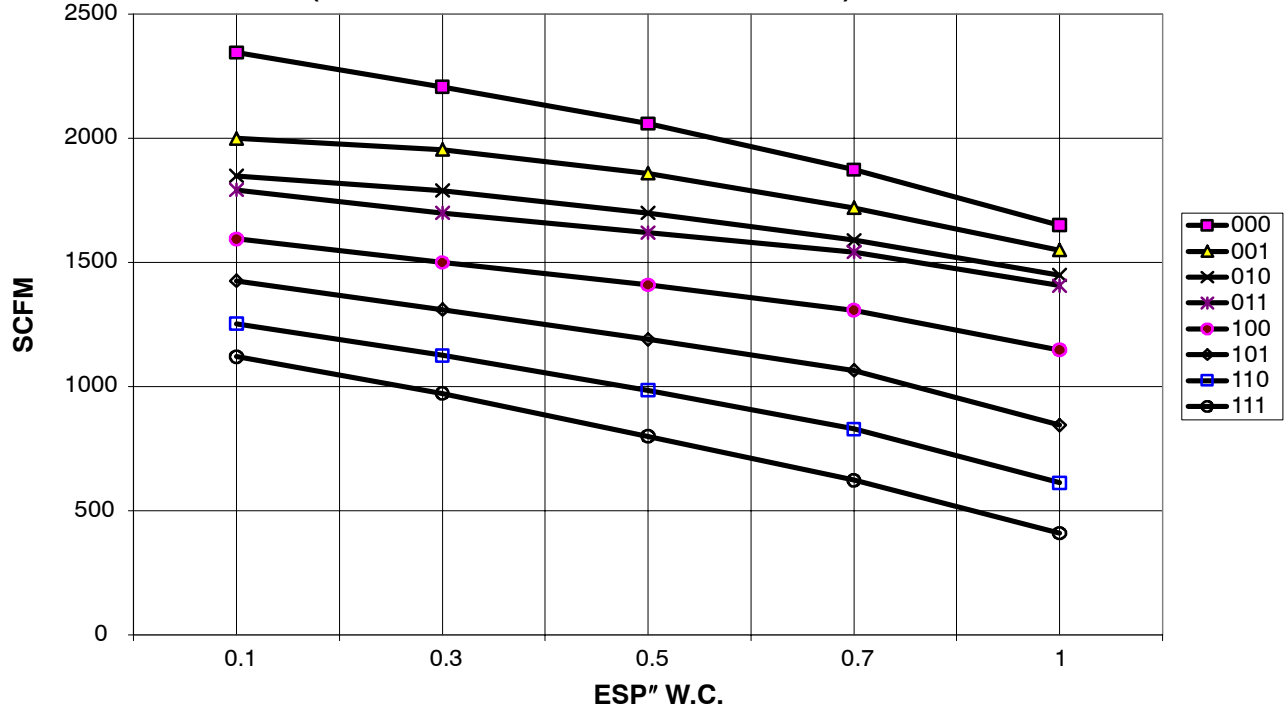

Figure 10

***9MPV125 COOLING**
(CFM VS. EXTERNAL STATIC PRESSURE)



Circulation Air Blower Data - *9MPV(A1 & A2)

Heating, Cooling & Continuous Airflow Settings

Figure 11

***9MPV125 Lo HEAT**
(CFM VS. EXTERNAL STATIC PRESSURE)

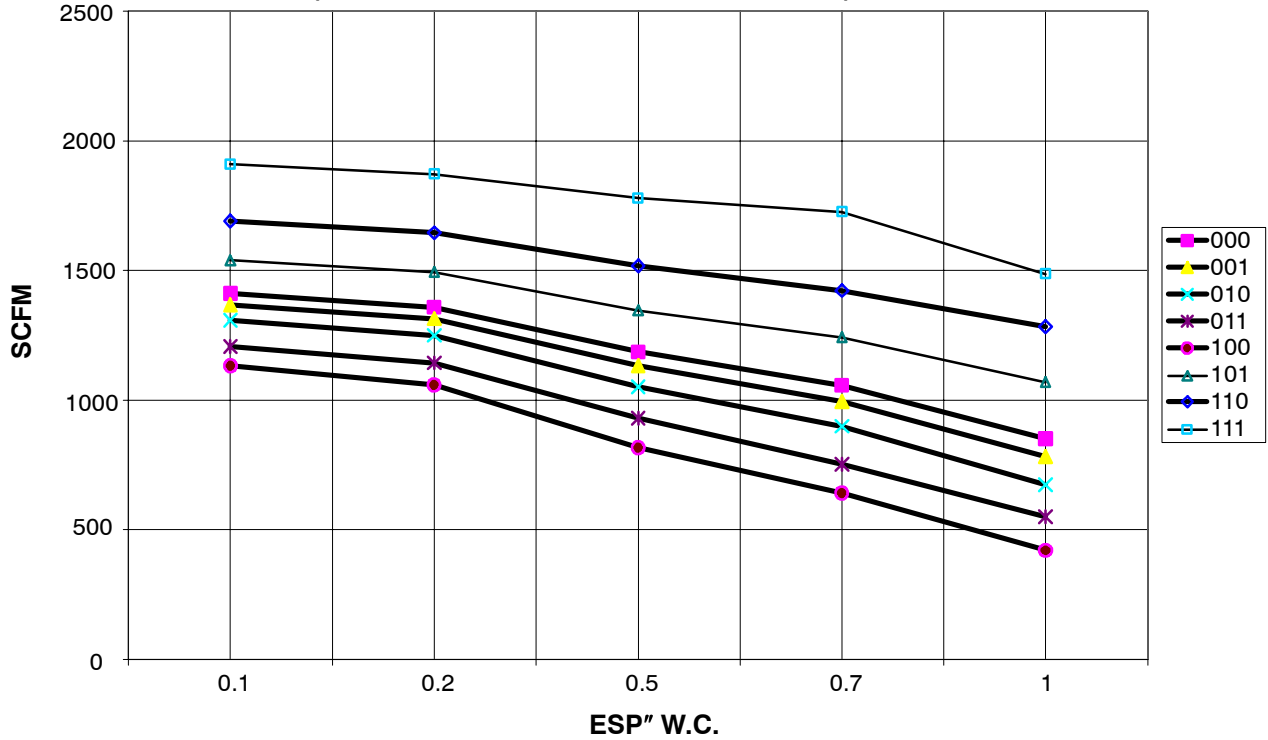
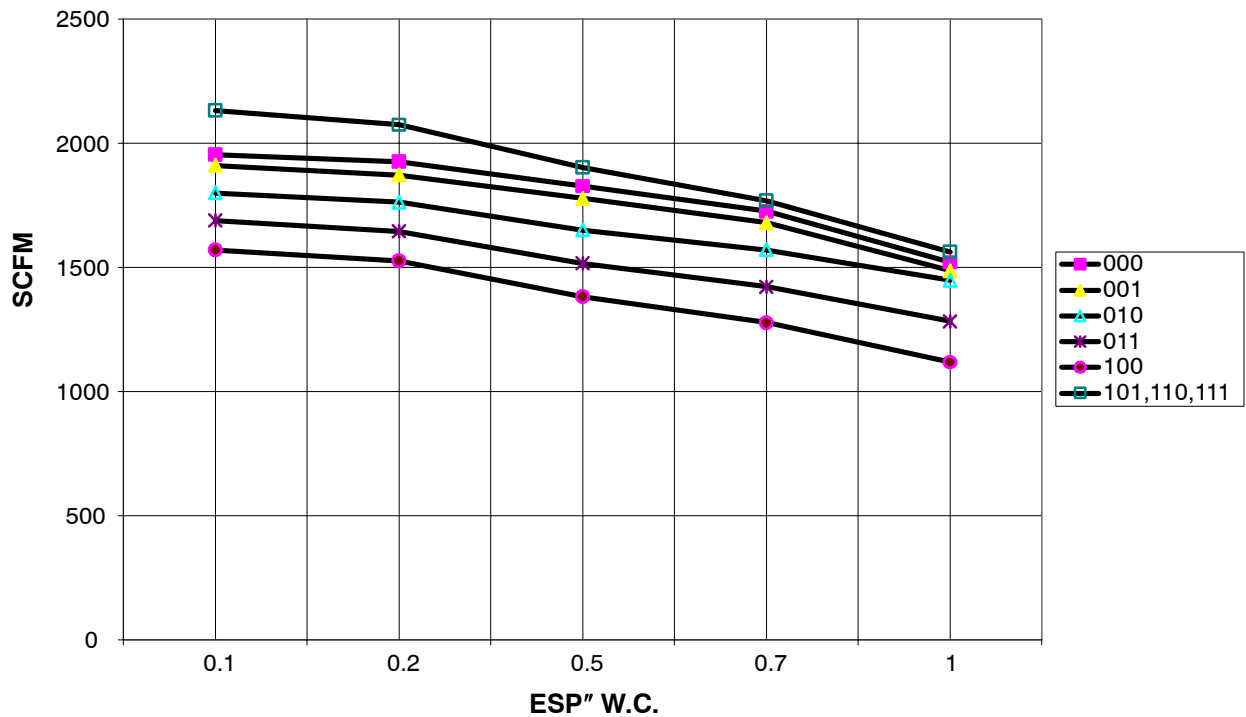

Figure 12

***9MPV125 Hi HEAT**
(CFM VS. EXTERNAL STATIC PRESSURE)



TECHNICAL SERVICE DATA *9MPT (A1 & A2)

Specifications								
	*9MPT050F12A		*9MPT075F14A		*9MPT100J16A		*9MPT125L20A	
General	Nat	L.P.	Nat	L.P.	Nat	L.P.	Nat	L.P.
Transformer Size (VA)	40							
T'stat Heat Anticipator	.10							
Input (Btuh) Std/Alt.	Hi Fire	50,000	75,000	100,000	125,000			
	Lo Fire	35,000	53,000	70,000	87,500			
Output (Btuh) Std/Alt.	Hi Fire	46,000	69,000	92,000	115,000			
	Lo Fire	32,200	48,800	64,400	80,500			
Temp. Rise (°F)	Hi Fire	35-65	40-70	40-70	40-70			
	Lo Fire	25-55	30-60	30-60	30-60			
Electrical (Volts/Hz/FLA)	115/60/9.8		115/60/9.0		115/60/9.0		115/60/11.2	
Gas & Ignition								
Gas Type	Nat.	L.P.	Nat.	L.P.	Nat.	L.P.	Nat.	L.P.
Std. Main Orifices (No/Size)	2/42	2/54	3/42	3/54	4/42	4/54	5/42	5/54
Gas Valve (Honeywell)	SV 9541	SV 9541	SV 9541	SV 9541	SV 9541	SV 9541	SV 9541	SV 9541
Regulation Type	SNAP	SNAP	SNAP	SNAP	SNAP	SNAP	SNAP	SNAP
Manifold Press.	Hi Fire (" WC)	3.5	10.0	3.5	10.0	3.5	10.0	3.5
	Lo Fire (" WC)	1.7	4.9	1.7	4.9	1.7	4.9	1.7
Pilot Orifice Size	.018	.011	.018	.011	.018	.011	.018	.011
Ignition Type/Series	HSP	HSP	HSP	HSP	HSP	HSP	HSP	HSP
Combustion								
Flue Outlet Size (Inches)	2		2		3		3	
Std. Outlet Temp (° F)	<140		<140		<140		<140	
@ Blower / @ Transition Box (Hi Fire)								
Std. Pressures (" of WC)								
5' No Elbows	-1.80 / -2.60		-1.80 / -2.60		-1.80 / -2.60		-1.80 / -2.60	
40' +5-90° DWV Elbows	-1.30 / -2.30		-1.30 / -2.30		-1.70 / -2.50		-1.70 / -2.50	
@ Blower / @ Transition Box (Lo Fire)								
Std. Pressures (" of WC)								
5' No Elbows	-1.20 / -1.90		-1.20 / -1.90		-1.20 / -1.90		-1.30 / -2.30	
40' +5-90° DWV Elbows	-1.00 / -1.80		-1.00 / -1.80		-1.00 / -1.80		-1.20 / -2.20	
Fan Controls								
Fan Control (Type)	HW ST9162A							
Fan Control On	30/60							
(Timed-secs) Off	60,100,140,180							
Limits & Controls								
Rollout Switch (°F)	300		300		300		300	
Limit Control Setting (°F)	260		210		240		180	
Std. Pressure Sw. (Part No)	1013515		1013515		1013515		1013166	
Blower Switch Pressure (Close)	0.95		0.95		0.95		1.30	
Blower Switch Pressure (Open)	0.80		0.80		0.80		1.10	
Transition Switch Pressure (Close)	1.70		1.70		1.70		1.80	
Transition Switch Pressure (Open)	1.50		1.50		1.50		1.60	
High Altitude Pressure Sw. (Part No)	1013165		1013165		1013165		1013157	
Blower Switch Pressure (Close)	0.70		0.70		0.70		0.85	
Blower Switch Pressure (Open)	0.55		0.55		0.55		0.70	
Transition Switch Pressure (Close)	1.40		1.40		1.40		1.70	
Transition Switch Pressure (Open)	1.20		1.20		1.20		1.50	
Blower Data								
Type & Size	11-8		11-10		11-10		11-10	
Motor Amps/Rpm	10/1050		10/1050		10/1050		13/900	
Motor Type/H.p.	PSC/1/2		PSC/1/2		PSC/1/2		PSC/3/4	
Cap. Mfd/Volts	10/370		10/370		10/370		40/370	
Filter Type	16x25x1		16x25x1		16x25x1		16x25x1 (2)	
Cool Cap. (Tons) @ .5" W.C. L, ML, MHi & Hi	1 1/2, 2, 2 1/2, 3		1 1/2, 2, 2 1/2, 3.5		2 1/2, 3, 3 1/2, 4		3 1/2, 4, 4 1/2, 5	
Gas Conversion Kits All Models								
Nat to LP	NAHF002LP *1011789							
LP to Nat	NAHF002NG *1011787							
*Order from Service Parts								

CIRCULATION AIR BLOWER DATA *9MPT (A1 & A2)

For 050(A1 & A2) Models 3 Ton Units

For 075(A1) Models 3 Ton Units

External Static Pressure Inches of W.C.	Speed Tap	CFM			
		Low	Med L	Med H	Hi
0.1		826	1083	1301	1408
0.2		804	1050	1242	1347
0.3		770	1028	1195	1295
0.4		735	985	1153	1237
0.5		698	952	1093	1183
0.6		657	909	1040	1118
0.7		---	863	935	1053
0.8		----	812	865	976
0.9		---	---	802	887
1.0		---	---	720	787

External Static Pressure Inches of W.C.	Speed Tap	CFM			
		Low	Med L	Med H	Hi
0.1		706	917	1163	1368
0.2		677	875	1120	1319
0.3		636	840	1076	1263
0.4		595	812	1031	1202
0.5		546	766	987	1148
0.6		490	702	889	1077
0.7		---	630	821	989
0.8		---	550	750	914
0.9		---	462	676	833
1.0		---	---	601	747

For 100(A1 & A2) Models 4 Ton Units

For 125(A1 & A2) Models 5 Ton Units

External Static Pressure Inches of W.C.	Speed Tap	CFM			
		Low	Med L	Med H	Hi
0.1		823	1109	1527	1850
0.2		795	1087	1482	1791
0.3		747	1056	1426	1720
0.4		677	1016	1382	1648
0.5		617	970	1317	1575
0.6		544	854	1245	1485
0.7		---	763	1154	1401
0.8		---	652	1043	1284
0.9		---	---	905	1161
1.0		---	---	737	1028

External Static Pressure Inches of W.C.	Speed Tap	Low	Med L	Med H	Hi
		0.1		1720	1910
0.2		1686	1881	2087	2268
0.3		1644	1833	2024	2201
0.4		1600	1777	1961	2131
0.5		1533	1720	1891	2029
0.6		1494	1647	1804	1948
0.7		1413	1571	1708	1820
0.8		1306	1470	1604	1730
0.9		----	1349	1484	1614
1.0		----	----	1328	1430

For 075(A2) Models 3.5 Ton Units

External Static Pressure Inches of W.C.	Speed Tap	Low	Med L	Med H	Hi
	0.1		695	1025	1455
0.2		674	1001	1410	1662
0.3		653	951	1366	1601
0.4		631	921	1309	1530
0.5		609	891	1252	1460
0.6		569	845	1187	1380
0.7		529	799	1122	1300
0.8		490	730	1030	1190
0.9		---	680	950	1080
1.0		---	---	831	969

Wiring Diagram (1/2 HP DC Blower Motor) *9MPV050(A1)

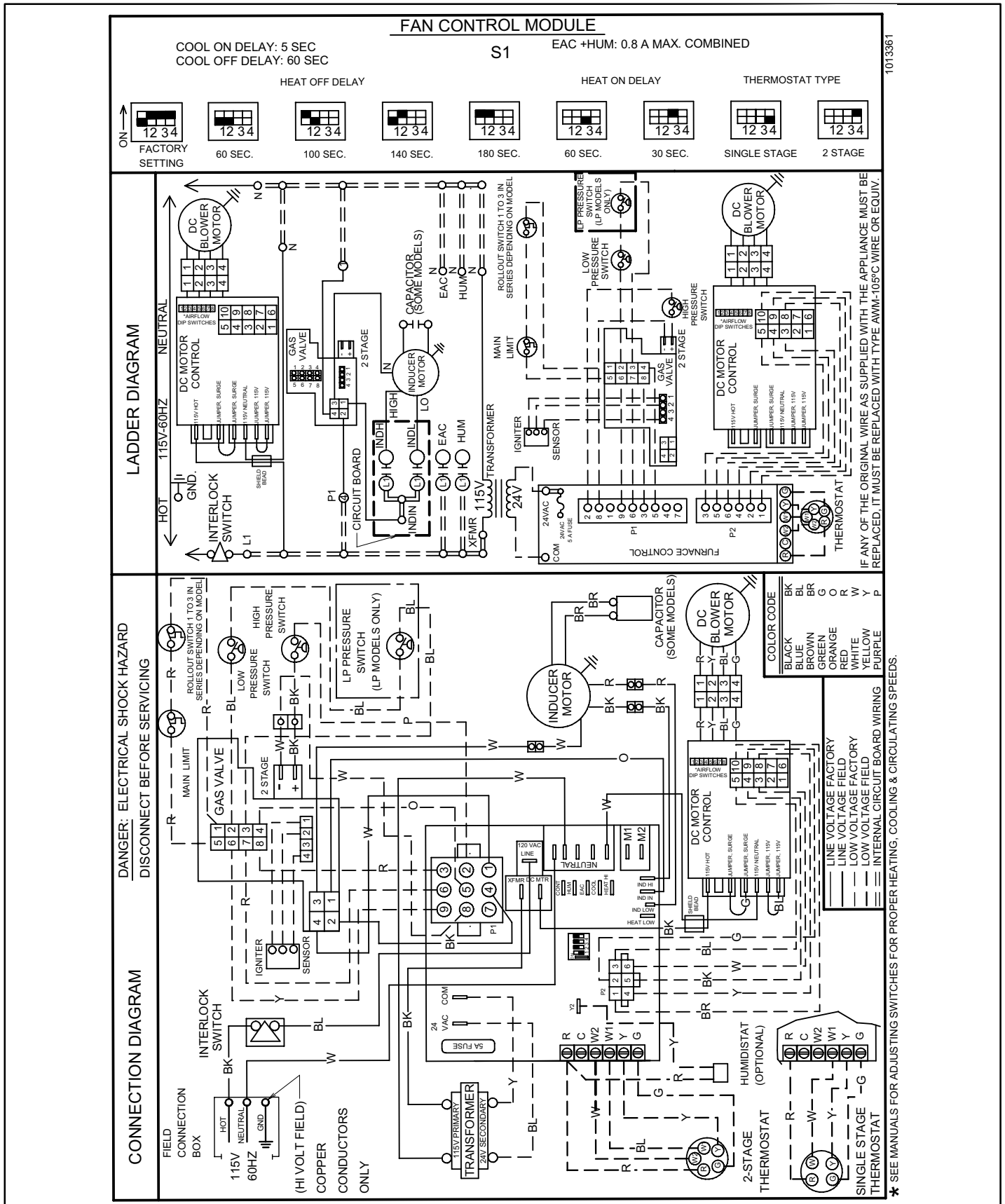

Wiring Diagram (1 HP DC Blower Motor) *9MPV075, 100 & 125(A1)

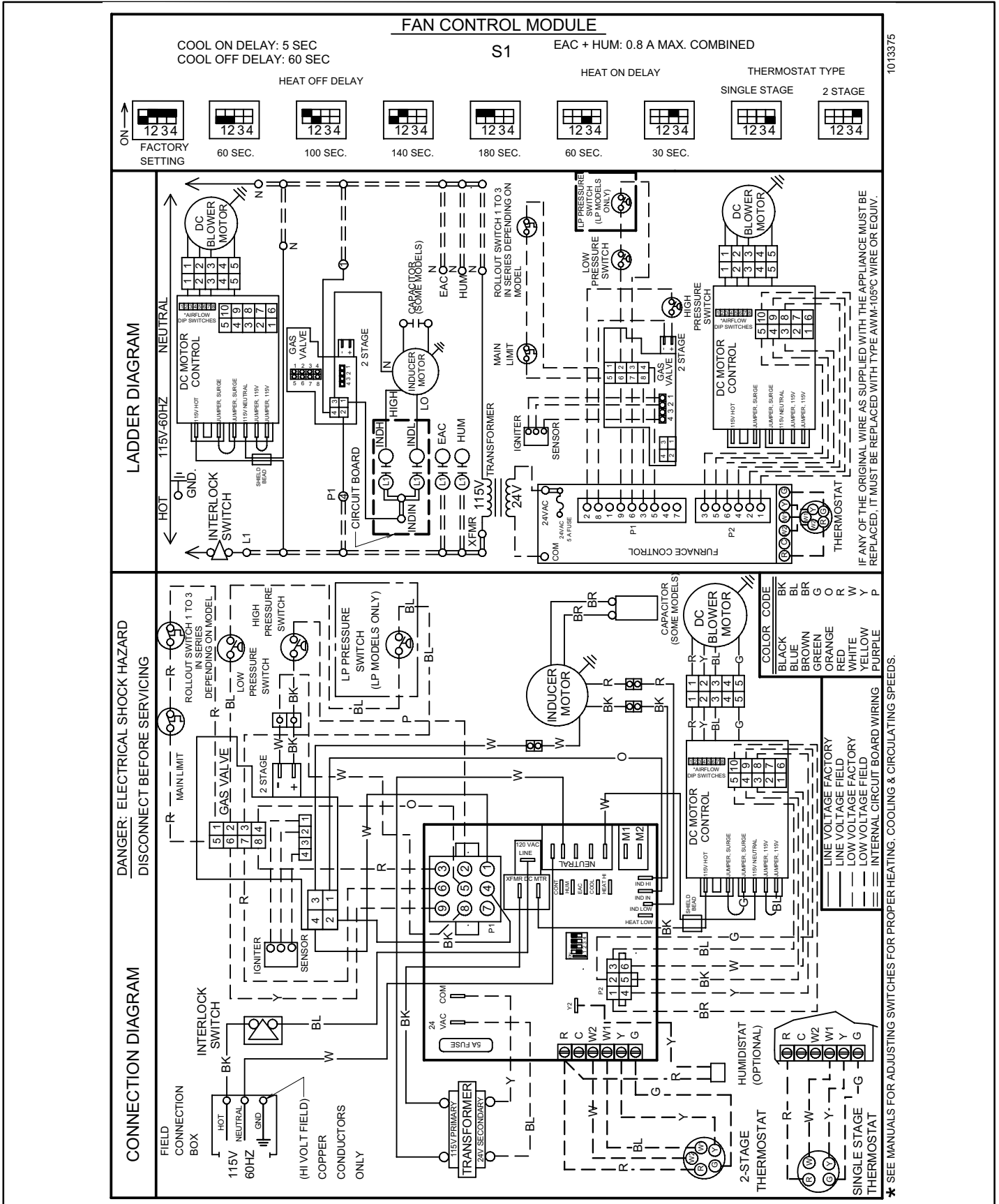

Wiring Diagram (1/2 HP DC Blower Motor) *9MPV050(A2)

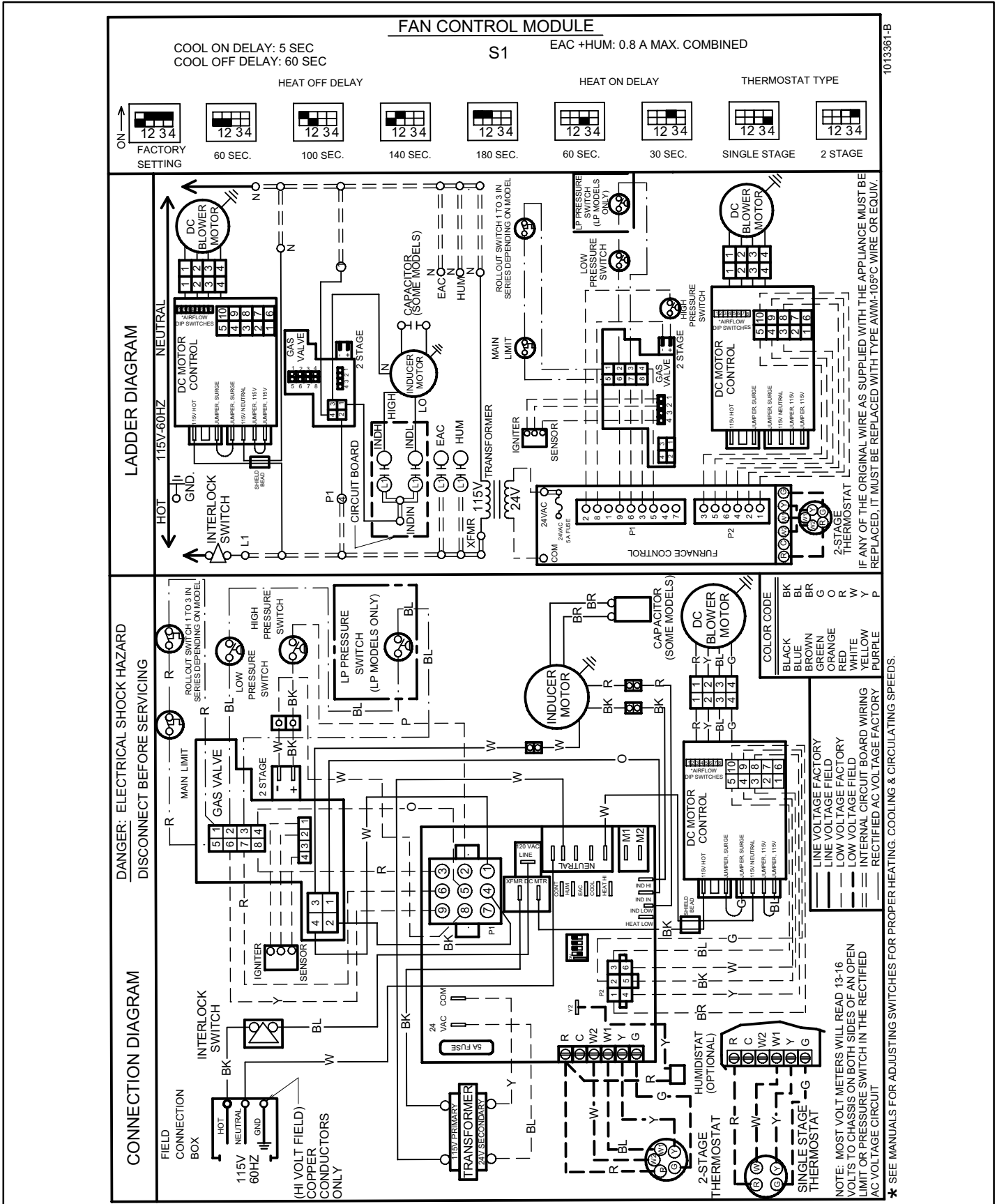

Wiring Diagram (1 HP DC Blower Motor) *9MPV075, 100 & 125(A2)

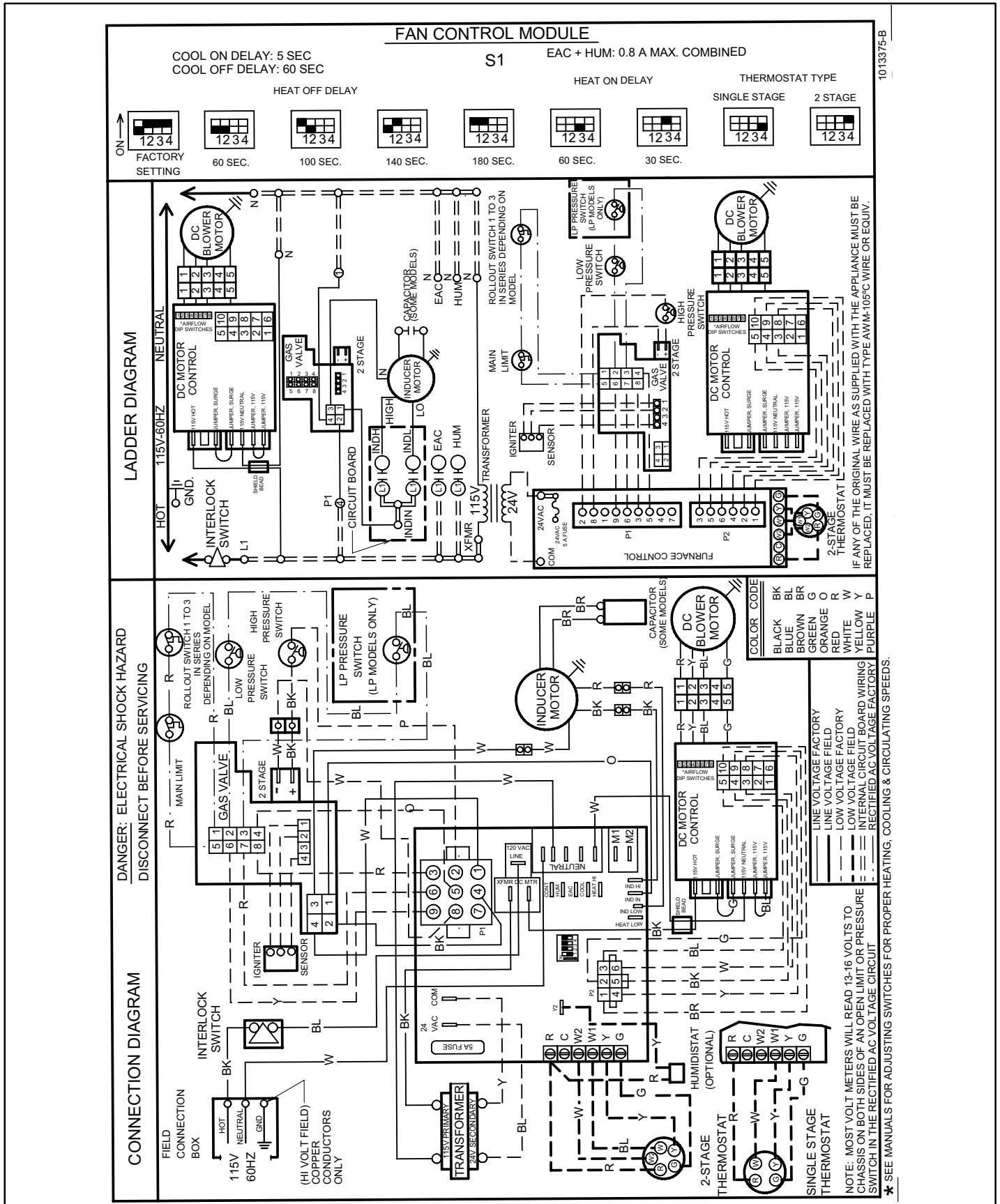

Wiring Diagram *9MPT(A2)

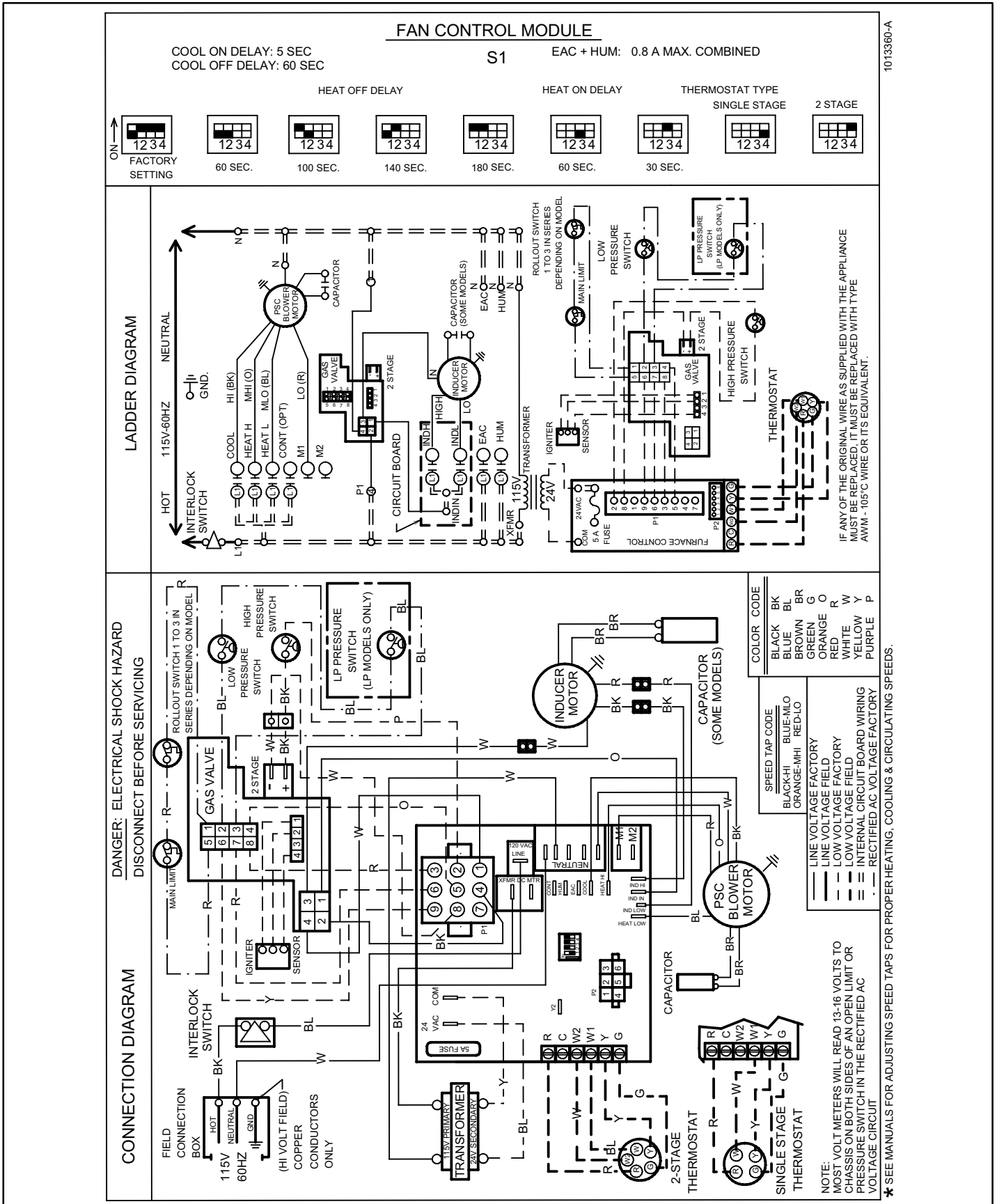

1013380-A

INDEX

A

Adjusting Heat Anticipator, 9
Adjusting Manifold Pressure, 6
Air Proving Switch, *See* Pressure Switch

B

Blower Assembly, Conditioned Air, 22
Blower Rotation, 27
Blower Speeds, Changing, 25
Blower Speeds, Selecting, 23
Blower, Exhaust, 17
Burners, 7

C

Capacitors, 22
Checking Approximate Air Flow, 25
Checking Capacitors, 22
Checking External Static Pressure, 24
Checking Flame Current, 22
Checking Grounding, 4
Checking Input (Firing) Rate, 5
Checking Manifold Pressure, 6
Checking Temperature Rise, 8
Combustion Air/Vent Piping, 13–16
Combustion Blower. *See* Exhaust Blower
Condensate Drain Trap, 17
Control Wiring, 11

D

Diagnostics, 20–21
“DIP” Switch Settings, ST9162A, 18
Drain Trap, Condensate, 17

E

Electrical Supply, 4
Electrical Variation (SV9541Q), 42
Electronic Fan Timer, 20
Exhaust Blower, 19
External Static Pressure, Checking, 28

F

Fan Timer, Electronic, 18
Flame Current, Checking, 22
Flash Codes, 21

G

Gas Valve/Ignition Control, Honeywell SV9541Q, 19
Ground, Electrical, 4

H

Heat Anticipators, 9
Heat Exchanger Removal/Replacement, 38
High Altitude Operation, 7
Honeywell ST9162A Fan Timer, 18
Honeywell SV9540Q Gas Valve/Ignition Control, 19

I

Interlock Switch, 5
Introduction, 1

L

Limit Switches, 11

INDEX

P

Piping, Vent/Combustion Air, 13-16
Polarity, Line Voltage, 4
Pressure Switches, 12-14
Pressures, Approximate Operating, 13

R

Roll Out Limit Switch, 11
Room Thermostat, 8

S

Sequence of Operation Chart, SV9541Q, 39
ST9162A Testing Sequence, 19
Supply, Electrical, 4
Supply, Gas, 5
SV9541Q System Operation, 20
Switch, Blower Door Interlock, 5
Switch, "DIP"- ST9140, 18
Switch, Auxiliary Limit, 10
Switch, LP Gas Pressure, 12
Switch, Limit, 11

Switch, Pressure, 12-13
Switch, Roll Out Limit, 11

T

Technical Service Data, 44; 52
Temperature Rise, 8
Testing Sequence, ST9162A/SV9541Q, 21
Thermostat, Room, 8
Troubleshooting Chart, Honeywell SV9541Q, 37-38

U

Unit Identification, 2

V

Vent Termination, Concentric, 16
Vent Termination, Standard, 14
Vent/Combustion Air Piping, 14

W

Wiring Diagram, 54-59
Wiring, Control, 10