

MULTI*PULSE*[®]

AM SERIES PULSE BOILER TROUBLESHOOTING GUIDE FOR CERTIFIED CONTRACTORS ONLY



TABLE OF CONTENTS

SECTION 1: OPERATION

Boiler Operating Lights - Location and function	3
Sequence of Operation (with lights)	3
Wiring Diagrams (AM-100/-150/-300)	5
Lighting and Operating Instructions	8

SECTION 2: TROUBLE SHOOTING

Preliminary Operational Check	9
-------------------------------------	---

- Boiler is not running:

<u>Condition</u>	<u>GC-4A Light</u>	<u>Red Light</u>	<u>Amber Light</u>	
A	Off	Off	Off	9
B	Off	Off	On	10
C	Off	On		11
D	On			12
E	Blinking			13

- Boiler is running:

Condition 1. Boiler ignites: runs for 8 seconds then shuts off	15
Condition 2. Boiler attempts ignition (8 seconds) - shuts off with a “cough” or no ignition	16
Condition 3. Boiler is “short cycling”	19
Condition 4. Boiler and condensate water leaks	22
Condition 5. Boiler noise (control and adjustment)	24
a) Prolonged stutter on start-up	25
b) Combustion/operating noise	26
c) Vibration noise	27
d) Objectionable exhaust noise	27
e) Objectionable (localized)	28

SECTION 3: SERVICING/REPAIR PROCEDURES

Service Tools List	29
Fan Pressure Check	29
Gas Supply Pressure Check	29
Gas Input Rate Check (Metered and Differential Methods)	30
Adjusting Input Rate	30
Flue Box Adaptor Repair (AM-300)	30
Fan Inlet Gasket Replacement (AM-300)	31
Air Inlet Orifice Repair (AM-300)	31
Ignition Wire Check	31
Wire Harness Assembly Replacement (AM-100 and 150)	31
Exhaust Cushion Chamber (ECC) and/or “O” Ring Replacement (AM-100 and 150)	33
Disassembling AM-300 Boiler	33
Leak Check (AM-300)	35
-Reassembly AM-300 Boiler	35
-Reposition Boiler in it's location (AM-300)	36
Heat Exchanger Replacement (AM-100 and 150)	37
Boiler Reassembly (AM-100 and 150)	37
Quick-Check Trouble Shooting Guide – GC-4A	39

SECTION 4: REPLACEMENT PARTS LIST

Part Identification/Figs. 9 thru 12 (AM-100 / -150 / -300)	40
--	----

SECTION 1: OPERATION

BOILER OPERATING LIGHTS

AMBER LIGHT	Part of 115V ON-OFF rocker switch (SW1). Side of electric box (AM-100 and AM-150). Front top of boiler (AM-300). Lit when switch is on.	GC-4A LIGHT	On GC-4A ignition control - visible thru a cutout in control cover near the 6-pin Molex connector. OFF when no 24V to control (no call for heat). Lit when boiler is running, GC-4A is in ignition sequence or on "hold" - refer to operating sequence. "Blinking" when GC-4A is in "lockout" or in the middle of a retrieval period.
RED LIGHT	Top of electric box (AM-100 and AM-150). Front top of boiler (AM-300). Lit when all operational controls are calling for heat and 24V is supplied to the GC-4A ignition control.	LAMP CHECK	Red and green bulbs can be checked with Volt/ohm meter: disconnect the lamp from the circuit and check across the leads for continuity. Replace any burned out lights or loose wiring.
GREEN LIGHT	Top of electric box (AM-100 and 150). Front top of boiler (AM-300). Lit when gas valve is energized (24V).		

SEQUENCE OF OPERATION (WITH LIGHTS)

1. Gas On/Power On. With Rocker switch SW1 (On/Off switch) closed (amber light is ON) 115/24V transformer is powered. Refer to figure 1, 2 or 3 for boiler wiring diagrams.
2. Boiler thermostat calls for heat; "T-T" contacts CLOSE; and circulator relay R1 (AM-100 and AM-150 only) is energized. The circulator relay contacts (C1R1) close starting the circulator pump (AM-100/-150).
3. 24 volts is also supplied to the high limit. If the limit (automatic reset type) is "OPEN" (Red Light OFF) due to high water temperature, the ignition control waits until limit closes. When the limit closes (Red Light ON), the GC-4A ignition control is energized (GC-4A Light ON) and checks the position of the Combustion Prove Switch (PS1) contacts (N.O.- NORMALLY OPEN). On AM-150, the blocked inlet switch (PS3) contacts (N.C.-NORMALLY CLOSED) are also checked. If the (PS1) contacts are OPEN **and** the (PS3) contacts (AM-150 only) are "CLOSED", the GC-4A control will begin the timed ignition sequence. If either or both of the pressure switch contacts is in an incorrect position, the GC-4A goes on "HOLD" (Red Light "ON"; GC-4A Light "ON") until switch position is corrected.
4. With the above condition satisfied, the GC-4A control will begin a timed pre-purge sequence (35-seconds); start the fan; and check the fan Prove Switch (PS2) contact position. This switch contact (N.O.), must close proving blower operation before any gas ignition will occur. If the Fan Prove Switch (PS2) contacts are "CLOSED" after the initial 35-second pre-purge, the control will continue with an attempt for gas ignition. If the (PS2) contacts remain "OPEN" there will be no attempt for ignition (no spark or gas valve will energize) but, the fan will continue to run. After an additional 26-seconds, the control will recheck the contacts on (PS2). If the contacts remain open, again there will be no attempt for ignition and the fan will continue to run. The control will check the contact on switch (PS2) three more times at 26-second intervals. If the contacts remain open, there will be no attempt at ignition. After the fifth check of the contacts, the fan will remain energized for a 30-second post-purge period, after which the ignition sequence will end and the GC-4A light will begin to blink (Red Light ON) indicating "LOCKOUT" (temporary). This ignition sequence will have taken 2 min. 45 seconds. Fifteen minutes later, the control will automatically begin a second ignition sequence attempt. If the condition remains uncorrected the retry sequence above will be repeated up to 10 times before a 100% system-lockout occurs. See "AUTOMATIC RESTART FEATURE" section.

5. The ignition sequence (8 sec. duration) is controlled by the module which provides a spark at the spark plug & energizes the gas valve (Green Light "ON"). The pre-purge blower continues to operate during this period.

If ignition occurs during the 8-second attempt, the combustion pressure is sensed by the Prove Switch (PS1) with switch contact (R-W) closing and proving combustion to the GC-4A control. The fan and ignitor are then shut off; the gas valve remains energized; boiler runs (Red Light ON; Green Light ON) and the GC-4A control timer circuits are reset. Fan Prove Switch (PS2) senses the fan shutdown and (PS2) contacts open. Boiler operation will continue until "Call for Heat" is satisfied.

If ignition does not occur during the 8-second trial period, the spark and gas valve will be "de-energized" (Red Light ON; Green Light OFF) and the fan will continue to run. After 26-seconds, if the (PS2) contacts are closed, the control will initiate a second 8-second trial for ignition (Red Light ON; Green Light ON). This sequence of 26-seconds OFF, 8-seconds ON, will occur 3 more times. If, after the fifth trial for ignition, combustion is not sustained, the ignitor and gas valve will be de-energized and the fan will continue for a 30-second post-purge, after which it will shut off. This ignition sequence will have taken 3 min. 30sec. (Red Light ON; Green Light OFF; GC-4A light blinking). The GC-4 control is on "Temporary Lockout". Fifteen minutes after completing this ignition sequence, the control will automatically initiate a second (5-trial) ignition sequence. See "Automatic Restart Feature" section for additional sequencing details.

AUTOMATIC RESTART FEATURE: The GC-4A ignition control is equipped with an automatic reset feature. If the control completes an ignition sequence (5 attempts for ignition) without sustaining or proving gas ignition, the control will go into a 15-minute "Temporary Lockout" mode (GC-4A light blinking) after which the control will initiate a second (5-trial) ignition sequence (GC-4A Light ON). If combustion is not sustained during the second ignition sequence, the control will again go on a 15-minute "Temporary Lockout", followed by another ignition sequence. This pattern will repeat an additional 10 times (3 hours 45 minutes total), at which time the control will produce a 100% "System Lockout" (GC-4A light blinking), requiring an operating control or line switch reset. To reset the boiler during any of the ignition sequences or from the "100% Lockout" condition, momentarily de-energize the ignition control by switching the rocker switch OFF and ON. This resets the module to the initial starting mode of the first ignition sequence.

HI-LIMIT OPERATION: If, during the run mode, the water temperature exceeds the limit setting, its contacts will open and the boiler will shut down (Red Light OFF; Green Light OFF; GC-4A Light OFF). However, relay R1 operating the circulating motor (AM-100 and AM-150) will remain energized. After the water temperature drops below the limit set point it's contacts close (Red Light ON) and the ignition sequence is repeated (GC-4A Light ON). Refer to step #3.

"CALL FOR HEAT" SATISFIED: When the control thermostat is satisfied, its contacts will open, de-energize gas valve; relay R1 (AM-100/-150) and shut the boiler off. (Red Light OFF; Green Light OFF, GC-4A Light OFF). The ignition module resets awaiting the next call for heat.

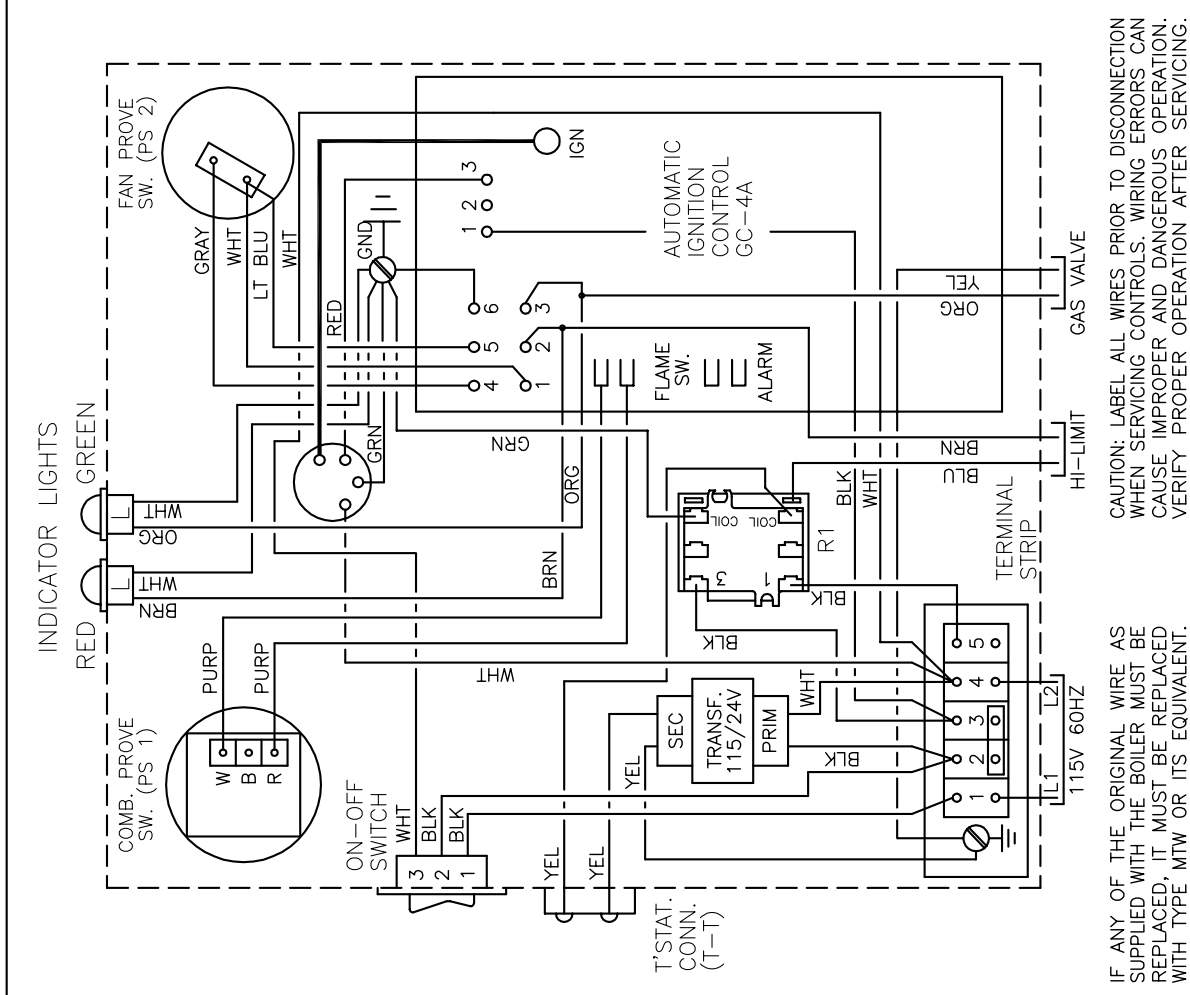
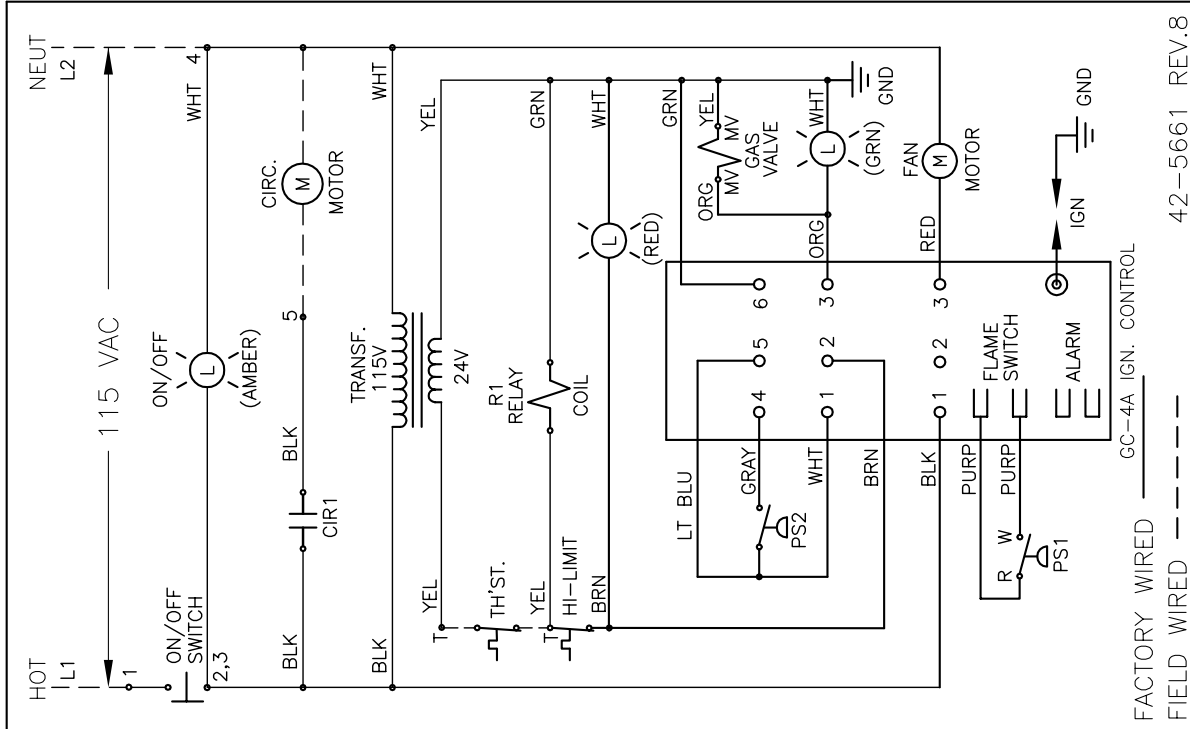
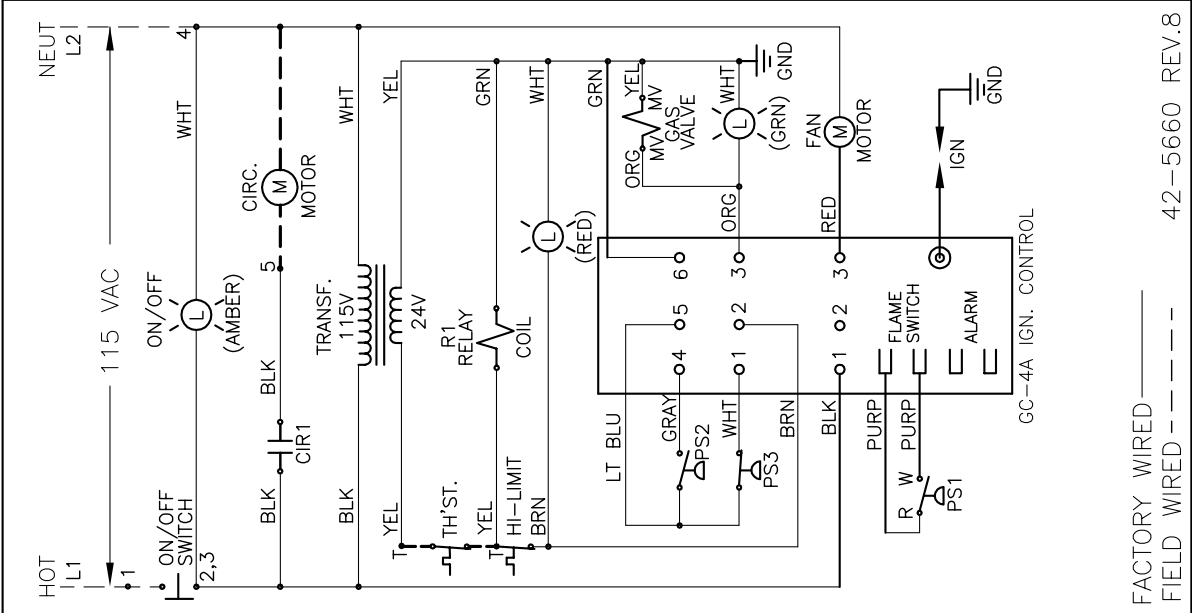
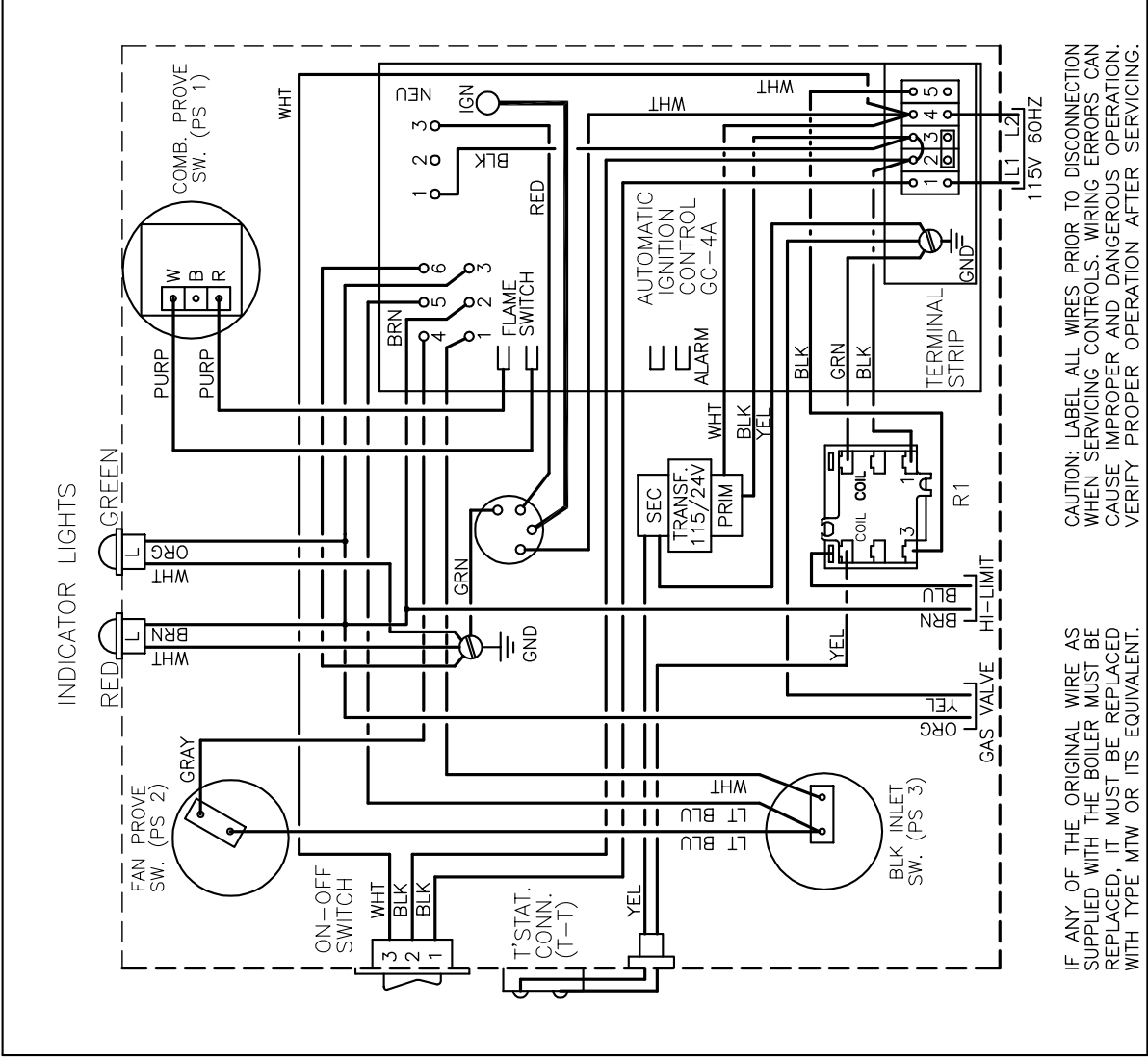

FIGURE 1
AM-100 SCHEMATIC & LADDER WIRING



FACTORY WIRED _____
 FIELD WIRED - - - - -

42-5660 REV.8



IF ANY OF THE ORIGINAL WIRE AS SUPPLIED WITH THE BOILER MUST BE REPLACED, IT MUST BE REPLACED WITH TYPE MTW OR ITS EQUIVALENT.

CAUTION: LABEL ALL WIRES PRIOR TO DISCONNECTION WHEN SERVICING CONTROLS. WIRING ERRORS CAN CAUSE IMPROPER AND DANGEROUS OPERATION. VERIFY PROPER OPERATION AFTER SERVICING.

FIGURE 2
AM-150 SCHEMATIC & LADDER WIRING DIAGRAM

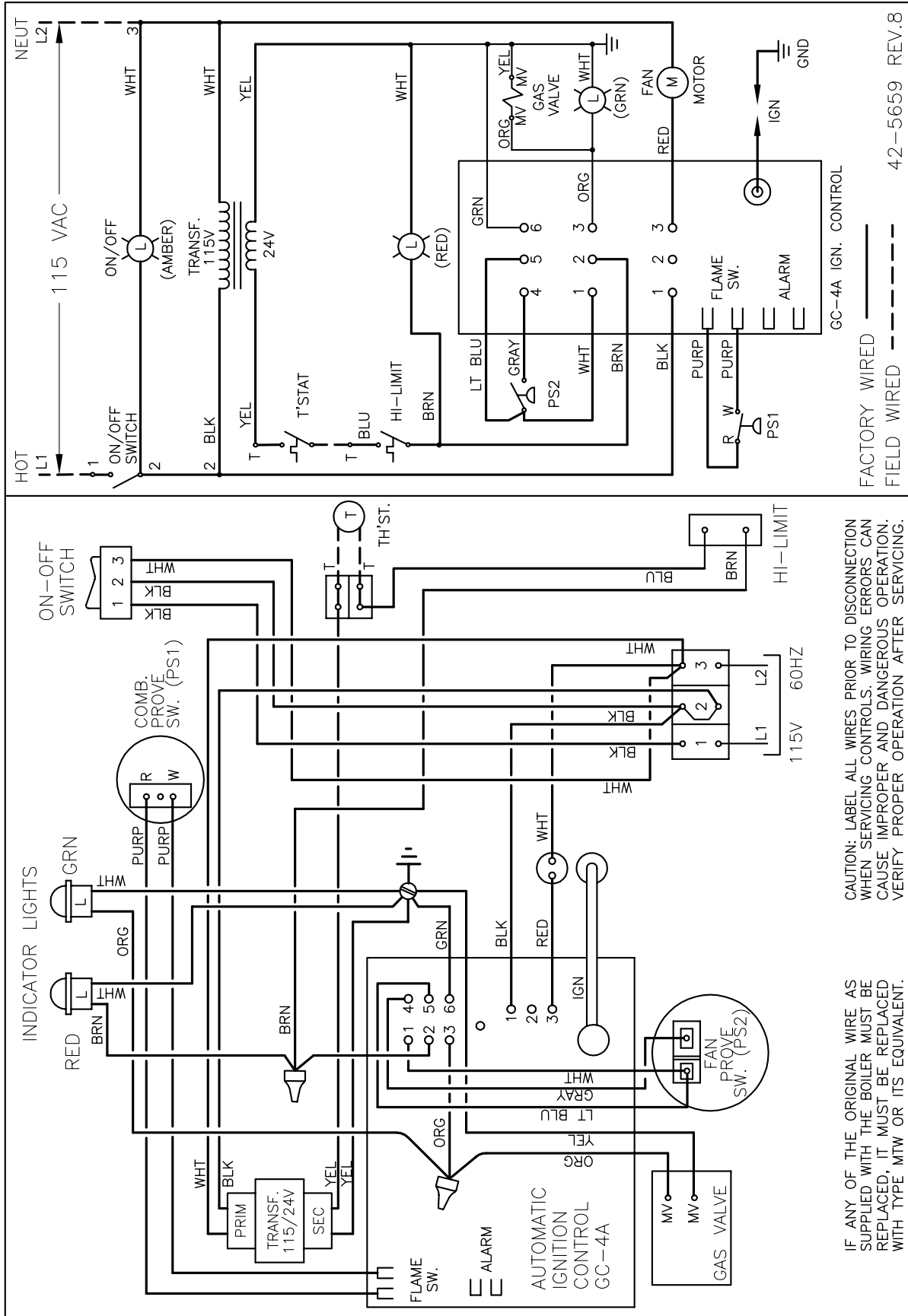

FIGURE 3 AM-300 SCHEMATIC & LADDER WIRING DIAGRAM

42-5659 REV.8

LIGHTING AND OPERATING INSTRUCTIONS (Honeywell VR-8305M Gas Valve)

WARNING:



If you do not follow these instructions exactly, a fire or explosion may result causing property damage, personal injury or loss of life.

- A. This appliance does not have a pilot. It is equipped with an ignition device which automatically lights the burner. Do **not** try to light the burner by hand.
- B. BEFORE OPERATING smell all around the appliance area for gas. Be sure to smell next to the floor because some gas is heavier than air and will settle on the floor.
- C. Use only your hand to turn gas control knob. Never use tools. If the knob will not turn by hand, don't try to repair it; call a qualified service technician. Force or attempted repair may result in a fire or explosion.
- D. Do not use this appliance if any part has been under water. Immediately call a qualified technician to inspect the appliance and to replace any part of the control system and any gas control which has been under water.

WHAT TO DO IF YOU SMELL GAS

- Do not light any appliance.
- Do not touch any electric switch; do not use any phone in your building.
- Immediately call your gas supplier from a neighbor's phone. Follow the gas supplier's instructions.
- If you cannot reach your gas supplier, call the fire department

LIGHTING INSTRUCTIONS

1. STOP! Read the safety information above on this page.
2. Set the thermostat to lowest setting.
3. Turn off all electrical power to the boiler.
4. This appliance is equipped with an ignition device which automatically lights the burner. Do **not** try to light the burner by hand.
5. Turn gas control knob clockwise  to "OFF".
Do not force!
6. Wait (5) five minutes to clear out any gas. Then smell for gas, including near floor. If you smell gas STOP! Follow "B" in the safety information above on this page. If you don't smell gas, go to the next step.
7. Turn gas control knob counterclockwise  to "ON".
8. Turn on all electrical power to boiler.
9. Set thermostat to desired setting.
10. If the appliance will not operate, follow the instructions "TO TURN OFF GAS TO BOILER" and call your service technician or gas supplier.

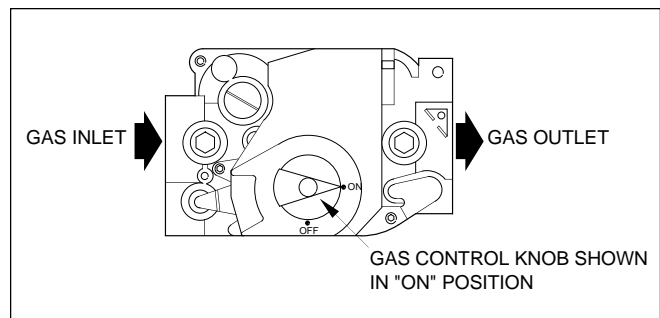

LIGHTING INSTRUCTIONS AM-100/150/300

TO TURN OFF GAS TO BOILER

1. Set thermostat to lowest setting.
2. Turn off all electrical power to the appliance if service is to be performed.
3. Turn gas control knob clockwise  to "OFF".
Do not force.

SECTION 2: TROUBLE SHOOTING

CAUTION: Label all wires prior to disconnection when servicing controls. Wiring errors can cause improper and dangerous operation. Verify proper operation after servicing.

- If the boiler **is** running, but exhibits one of the following conditions, observe the operating light conditions and use the procedure(s) under the appropriate heading on the referenced page(s) noted.

PRELIMINARY OPERATIONAL CHECK

Refer to Section 3 - "SERVICING PROCEDURES" for list of service tools.

- UPON ARRIVAL AT SERVICE CALL: First - check the status of the boiler operating lights. If the boiler is not running, follow the procedures under the appropriate heading on the referenced pages below.

IF BOILER IS **NOT** RUNNING:

<u>CONDITION</u>	<u>GC-4A LIGHT</u>	<u>RED LIGHT</u>	<u>AMBER LIGHT</u>	<u>REF. PAGE</u>
A	OFF	OFF	OFF	9
B	OFF	OFF	ON	10
C	OFF	ON	*	11
D	ON	*	*	12
E	Blinking	*	*	13-14

*Lights OFF indicate burned out bulb or loose wiring.

IF BOILER **IS** OPERATING (CONDITIONALLY):

<u>CONDITION</u>	<u>DESCRIPTION</u>	<u>REF. PAGE</u>
1	Boiler ignites (8 sec.) but shuts-off	15
2	Boiler cycles but won't light	16-19
3	Boiler "short-cycling"	19-21
4	Boiler condensate water leaks	22-23
5	Boiler noise - control/adjustment	24-28

CONDITION A

GC-4 LIGHT OFF; RED LIGHT OFF; AMBER LIGHT OFF.

This indicates no 115V to the boiler.

POSSIBLE CAUSE	VERIFICATION	SOLUTION
Power Supply	With a voltmeter, check for 115V. On AM-100 & 150 terminals 1 & 4. On AM-300 terminals 1 & 3.	If no 115V, check circuit breaker at disconnect switch and supply wiring. Connect if necessary.
		If 115V, proceed with this check.
Rocker Switch	With a voltmeter, check for 115V. On AM-100 & 150 terminals 3 & 4. On AM-300 terminals 2 & 3.	If no 115V, operate switch. If no 115V, check wiring to switch. If ok replace switch.
		If 115V but no amber light, proceed with check.
Amber Light	With a voltmeter, check for 115V across terminals 2 & 3 on Rocker Switch.	If 115V, replace switch.
		If no 115V, check wiring.

CONDITION B

GC-4A LIGHT OFF, RED LIGHT OFF, AMBER LIGHT ON

Turn Rocker Switch OFF and ON. If, within 10 seconds, the GC-4A light comes ON proceed to "CONDITION "E". Replace Red Light (if OFF). If GC- 4A light remains OFF, proceed with check.

POSSIBLE CAUSE	VERIFICATION	SOLUTION
Operational Control(s)	Turn Rocker Switch OFF. Place a jumper across T-T terminals. Turn Rocker Switch ON.	If GC-4A and/or Red Lights come ON check thermostat and other operational controls and adjust or replace as necessary.
		If lights remain OFF, proceed with check.
High Limit	(Keep T-T jumper in place). Turn Rocker Switch OFF. Jumper the high limit terminals. Turn Rocker Switch ON.	If GC-4A and/or Red Lights come ON, high limit is set too low or defective. Compare supply water temperature and limit setting. If settings are proper, replace limit.
		If lights remain OFF, high limit is OK.
Transformer	Rocker Switch ON. With a voltmeter, check for 24V across T-T terminals to ground.	If no 24V, replace transformer.
		If 24V transformer is OK, proceed with check.
AT THIS POINT RED LIGHT SHOULD BE ON - IF NOT, REPLACE LAMP		
GC-4A Ignition Control	Turn Rocker Switch OFF. Disconnect 6-pin Molex connector from GC-4A. Turn Rocker switch ON. With a voltmeter, check for 24V from pin 2 (brown wire) on connector to ground. REMOVE ANY JUMPERS USED FOR TEST.	If 24V, reattach connector to GC-4A. If GC-4A light remains OFF, replace GC-4A (and Red lamp if OFF). If no 24V, check wires (incl. grounds) and wire connections until 24V is established. If necessary, replace wire harness.

NOTE: Non-resistive spark plugs (i.e. - Champion WR-18, etc.) must **never** be used in combination with a GC-4 ignition module. Use only approved, resistance spark plugs (Champion FI-21503). High-voltage ignition wiring must **never** contact remaining boiler wiring.

CONDITION C

GC-4A LIGHT OFF, RED LIGHT ON

Turn Rocker Switch OFF and ON. If, within 10 seconds, the GC-4A light come ON, proceed to CONDITION “E”.

If after the toggle switch is turned “OFF” and “ON”:

- GC-4A light remains “OFF”.
- Red light is “ON” but there is no “Prepurge Cycle” or blower operation initiated (unit is in standby mode).
- Green light “ON” immediately - but no gas flows to unit. The ignition module has lost ground continuity between the module and ground. Replace terminal connection on the end of ground wire (green) leaving the module.

If GC-4A light remains OFF, proceed with this check.

POSSIBLE CAUSE	VERIFICATION	SOLUTION
Wiring	Check if green ground wire from GC-4A is securely fastened to the ground screw. Also check transformer ground.	If screw is loose, secure screw. If wires are not on a common screw rewire the grounds.
		If GC-4A light remains OFF, proceed with check.
GC-4A Ignition Control	Turn Rocker Switch OFF. Remove 6-pin Molex connector from GC-4A. Turn Rocker Switch ON. With a voltmeter, check for 24V from pin 2 (brown wire) on connector to ground.	If 24V, reattach connector to GC-4A. If GC-4A light remains OFF after 10 seconds replace GC-4A.
		If no 24V, check wiring and connectors until 24V is established.

CONDITION D

GC-4A LIGHT ON

(If Red or Amber lights are OFF, replace lamp or switch.) Boiler may be in an ignition sequence - wait 40 seconds for an attempt at ignition (Green Light ON).

If there is no attempt at ignition: turn Rocker Switch on boiler OFF and ON. Observe and clock the time the GC-4A light is ON.

- If within 45 seconds, the Green Light is lit; or there is an audible attempt at ignition, proceed to condition "E".
- If the GC-4A light is blinking after **3 min. 45 sec.**, proceed to condition "E".
- If the GC-4A light is ON after **3 min. 45 sec.** with no attempt at ignition, proceed with check below.

POSSIBLE CAUSE	VERIFICATION	SOLUTION
Combustion Prove Pressure Switch PS1 (N.O. Contacts) - Pressure Switch adjusting is factory set at 5" W.C.	Turn Rocker Switch OFF. Remove one purple wire from PS1 Pressure Switch. Turn Rocker Switch ON, wait 3 min. 45 sec.	If boiler has attempted ignition (Green Light ON) and the GC-4A light is blinking. Pressure Switch is defective. Replace switch.
		If GC-4A remains ON, Pressure Switch is ok. Reconnect purple wire and proceed with check.
Blocked Inlet Pressure Switch (PS3) (N.C. Contacts) (Factory setting fixed) Supplied on AM-150 only	Turn Rocker Switch OFF. Jumper Pressure Switch PS3 Terminals. Turn Rocker Switch ON. Wait 3 min. 45 sec.	If boiler is running, replace Pressure Switch.
		If GC-4A light is blinking, replace Pressure Switch (PS3) and proceed to condition "E".
		If GC-4A light is ON, Pressure Switch is ok. Proceed with check.
Wiring	Turn Rocker Switch OFF. Remove the 6-pin Molex connector from the GC-4A control. With an ohmmeter check for continuity from pin 5 (Lt Blue wire) to pin 1 (White wire) on the supply wiring side of the connector plug. NOTE: On the AM-150 contacts on PS-3 should be closed.	If no continuity, check wiring until continuity is obtained.
		If continuity, reattach connector to GC-4A. Turn Rocker Switch ON. If after 3 min. 45 sec. the GC-4A light is on (not blinking) replace GC-4A.

CONDITION E

GC-4 LIGHT BLINKING

Turn the Rocker Switch OFF and ON. Observe GC-4 light and clock ON time before it begins to blink.

If Red or Amber Lights OFF, replace lamp or switch.

If the boiler starts and runs, a temporary problem may have corrected itself, (I.E., low gas pressure or a blockage of the inlet, etc). However, there may also be a slow draining condensate or a partially blocked exhaust, see Blocked Exhaust under "CONDITION #2B". Stop and start the boiler a number of times to assure normal operation has been restored.

If boiler does not ignite or ignition is rough - see "CONDITION 2."

If GC-4A light is ON **3 min, 30 sec.**, then starts blinking and boiler attempted ignition - proceed to "CONDITION 2".

If GC-4A light is ON **3 min, 30 sec.**, then starts blinking and if boiler "coughs" or does not attempt ignition, proceed to "CONDITION 2".

If GC-4A light is ON **2 min, 45 sec.**, then begins to blink, measure fan pressure (see "PROCEDURES" section) and use one of the two procedures below.

<u>MODEL NO.</u>	<u>MINIMUM FAN PRESSURE (PS2)</u>
AM-100/-150	+1.4" W.C.
AM-300	+0.8" W.C.

1. If measured fan pressure exceeds the minimum for fan prove switch (PS2) operation.

POSSIBLE CAUSE	VERIFICATION	SOLUTION
Wiring	Turn Rocker Switch OFF. Remove the 6-pin Molex connector from the GC-4A. (Keep Fan Switch (PS2) jumper in place). With an Ohm-meter check for continuity across pin-4 (grey) and 5 (lt.blue).	If no continuity, check wire and connectors until continuity is obtained - reconnect Molex to GC-4A and run Fan Prove Switch check.
		If continuity but, condition above exists-replace GC-4A.
Fan Prove Switch (PS2) (N.O.) contacts (Factory Fixed Setting)	**Turn Rocker Switch OFF. Turn Rocker Switch ON. Jumper pressure switch (PS2) contacts.	If boiler starts, (PS2) pressure switch is defective - replace it.
		If the GC-4A light begins to blink after 2 min. 45 sec., (PS2) switch is ok. Proceed with check.
		If the boiler attempts to start and the GC-4A light blinks after 3 min.30 sec., (PS2) switch is defective - replace it.

** NOTE: Fan must be operating before placing jumper across switch PS2. Always remove jumper before resetting boiler.

CONDITION "E" continued...

2. If measured fan pressure is at or below the minimum for Fan Prove Switch (PS2) operation.

POSSIBLE CAUSE	VERIFICATION	SOLUTION
Fan Motor	Turn Rocker Switch and Gas Valve top knob OFF. Remove air cushion cover. (On AM-100 & -150 lift fan assembly out of boiler and check motor is securely fastened to the mounting plate). Disconnect the fan motor wire leads from the boiler wiring at quick connects provided. Turn the Rocker Switch ON. With a voltmeter, check for 115V across the supply leads from the boiler.	If you read 115V, proceed with verification.
		If no voltage, check for open circuit (see below).
	Turn Rocker Switch OFF. Reconnect fan leads to motor. (For AM-100 & -150, place fan assembly on ledge of air cushion chamber). Turn Rocker Switch ON.	If the motor runs, proceed with check.
		If motor does not run, replace motor fan assembly.
AM-300 Blower Wheel - Obstructed or loose	Turn Rocker Switch OFF. Remove fan from mounting studs and check blower wheel is secure on shaft, not rubbing against housing and free from obstruction.	If loose, secure blower wheel properly on shaft. If obstructed remove obstructions.
		If ok, proceed with verification.
AM-300 Blocked Air Inlet Orifice	Check for obstructions in air supply vent terminal and piping. On AM-300 check inlet orifice located in inlet adapter: see FIG. 7.	If obstructed, remove obstruction.
		If unrestricted, proceed with verification.
AM-100 and 150 Broken Impeller	Check that impeller is firmly secured to motor shaft.	If broken replace impeller and/or assembly.
Air Inlet Vent and Lines	Check air inlet terminal for blockage from freezing or debris.	If obstructed - clear vent inlet.
	Check vent lines for sagging low spots which can act as water trap and reduce the air supply.	If clear, proceed with vent line check.
		If sagging is observed, support pipe to remove "traps."
Open Fan Circuit GC-4A Control Checkout	Remove the three conductor Molex connector (with red and black wires) from GC-4 ignition control.	If no continuity, replace GC-4 ignition control following instructions packaged with replacement.
	CAUTION: 115 VAC supply. Turn Rocker Switch OFF and then ON. Within 30 sec. check for continuity across the two outer Molex connector sockets on the ignition control (Term. 1 & 3).	If continuity is ok - check wiring.

CONDITION "E" continued ...

POSSIBLE CAUSE	VERIFICATION	SOLUTION
Wiring to GC-4A (115V)	Turn Rocker Switch OFF. With an ohmmeter, check continuity of red & black wires of the 3-conductor Molex connector.	If no continuity on any wire, replace or repair as required.
		If all continuity checks ok, check if motor wire terminals mate correctly when joined.
		Turn gas valve top knob to "ON" after completing checkout.

CONDITION #1 - BOILER IGNITES (8 SECONDS) THEN SHUTS OFF

GC-4A Light is "ON", Red Light "ON", Green Light "ON" (during 8 second ignition trial). After 3 min. 45 sec (5 unsuccessful ignition trials) the GC- 4A light then blinks.

IF THE BOILER, WHEN IT RUNS, STOPS BEFORE THE GREEN LIGHT GOES OUT - PROCEED TO "CONDITION #3."

POSSIBLE CAUSE	VERIFICATION	SOLUTION
Copper Pressure Sensing Tube Runs from Gas Cushion Chamber (G.C.C.) valve plate to Combustion Prove-Pressure Switch (PS1).	Turn Rocker Switch OFF & remove top from Air Cushion Chamber (A.C.C.). (On AM-100 & -150 remove fan assembly). Check tube for breaks at the GCC valve plate & on the AM-300 at the fitting on the ACC wall. Check unions are tightly connected.	Repair or replace as necessary.
Pressure Switch (PS1) (Combustion Prove Switch)	If removed, replace fan assembly and air cushion chamber top and turn Rocker Switch ON.	If boiler runs more than 9 seconds (with jumper in place), replace switch (PS1).
	Immediately after boiler starts, place jumper across PS1 pressure switch terminals (R-W). DO NOT PUT JUMPER ON UNTIL GAS VALVE IS ENERGIZED. CAUTION: TERMINAL VOLTAGE EXCEEDS 300 VOLTS. (Remove jumper after test).	If boiler runs 8 seconds (stops when Green Light goes OFF) with the jumper in place, proceed with verification.
Wiring - Purple Wires (2) From PS1 to GC-4A Ignition Control	Check both purple wires from (PS1) pressure switch to ignition control. Connections must be secure to complete circuit from module.	If loose, reconnect wires. Repeat Pressure Switch verification. If boiler runs less than 9 seconds (with jumper in place), switch is ok.
		If no loose wires, replace GC-4A ignition module following instructions packaged with replacement.

CONDITION #2 - BOILER ATTEMPTS IGNITION (8 SECONDS) WITH ONLY A “COUGH” OR NO IGNITION: THEN SHUTS OFF

GC-4A Light is “ON”; Red Light “ON”; Green Light “ON”; - during each 8 sec. ignition trial (5 attempts). Unit does not run after 3 min. 45 sec. The GC-4 light then blinks.

NOTE: ON A START-UP, BOILER MAY LOCK OUT SEVERAL TIMES BEFORE ALL AIR IS PURGED FROM GAS LINE.

MEASURE FAN PRESSURE (SEE “PROCEDURES” SECTION) AND USE ONE OF THE THREE PROCEDURES BELOW.

- A. IF FAN PRESSURE MEASURES NORMAL: +1.5 to 1.9"W.C. for AM-100 & -150.
+1.0 to 1.4"W.C. for AM-300.

POSSIBLE CAUSE	VERIFICATION	SOLUTION
Gas Line Valves	Check that all valves in gas line, including combination gas valve, are in open position.	Open all gas valves in gas line.
Incorrect Gas Supply Pressure (should be between 4.5" to 7.0" W.C. for Natural Gas; 11" W.C. for Propane Gas)	With manometer, check gas supply pressure as described in “Procedures” section of this manual.	Adjust gas supply pressure as necessary.
Combination Gas Valve (24V)	Turn the Rocker Switch OFF and ON. After 35 seconds, with a voltmeter, check for 24V across the gas valve terminals (MV-MV).	If no 24V & no green light, check wiring. If intact and secure - replace GC-4A.
		If read 24V & green light OFF replace green lamp and proceed with check.
	Put manometer downstream of gas valve. When gas valve opens (Green Light “ON”) gas pressure should increase. (Manometer will read a purge fan pressure before valve opens).	If no indication of gas flow, replace gas valve. If gas flow is confirmed, proceed with check.
Check Ignition Circuit (GC-4 Ignition Control)	Turn Rocker Switch & Gas Valve top knob “OFF.” Turn Rocker Switch “On” & allow unit to purge to a sequenced lockout (temporary). Turn Rocker Switch “OFF” and remove high tension ignition lead from ignition control. Turn Rocker Switch “ON” & after 34 sec. (purge), check for spark with insulated screwdriver between the ignition control spud & ground. CAUTION: Hi-voltage Potential.	If spark is strong, control is ok. Reconnect ignition lead.
		If no spark, check that the white (neutral) lead is securely connected from the “NEU” spade connection on ignition module to neutral side of the 24V transformer.
		If secure and not sparking, replace the GC-4 ignition control.

CONDITION #2 continued ...

POSSIBLE CAUSE	VERIFICATION	SOLUTION
<p>Ignition Lead</p>	<p>Turn Rocker Switch "OFF." Remove cover from ACC. Remove the fan assembly on the AM-100 & -150. With an ohmmeter, check lead for continuity. Visually check lead wire and boot for tears, abrasions or "burn spots" indicating a short circuit.</p> <p>NOTE: Hi-voltage ignition lead wiring must not contact regular wiring on boiler.</p>	<p>If no continuity or damaged lead - then replace wire harness assembly. (See "Procedures" section). Reseal "ACC" chamber opening.</p>
		<p>If continuity & lead checks satisfactorily - proceed with verification.</p>
		<p>If visual check is ok perform ignition wire check ("Procedures" section).</p>
		<p>If ok proceed with verification.</p>
<p>Spark Plug</p> <p>Use only resistive-type spark plug (Champion FI-21503): Replace any non-resistive type plugs (WR-18/etc.)</p>	<p>Turn Rocker Switch & Gas Valve Top Knob "OFF". Remove spark plug from combustion chamber and visually check for ceramic cracks, carbon tracks, and wear. Attach the ignition lead to spark plug & place plug on head of boiler. Jumper Fan Prove Switch (PS2). Turn Rocker Switch "ON" and observe the spark during the ignition sequence.</p>	<p>If plug is ok - check gap (.100" to .125") and reassemble in boiler.</p>
		<p>If plug is worn or ceramic cracked - replace plug.</p>
		<p>If plug shows carbon tracks or excessive carbon deposits, clean plug and proceed with check.</p>
<p>Input Rate</p>	<p>Reassemble boiler. Turn Rocker Switch "OFF" & Gas Valve Top Knob "ON." Turn Rocker switch "ON" (start boiler).</p> <p>After boiler runs for at least 10 min. - check input rate according to one of two methods described under "Procedures" section of this manual. Adjust gas valve regulator as necessary to deliver desired input rate.</p> <p>To adjust pressure - turn OFF boiler/remove regulator cap on gas valve. Replace regulator cap (secure) before re-starting unit and determining effects of adjustment.</p>	<p>If boiler won't run & you suspect "overfire", check if pressure regulator adjusting screw is bottomed out. Turn screw counterclockwise (in 1/4 turn intervals) to decrease flow rate. After each adjustment replace pressure regulator cap before turning "ON" boiler.</p>
		<p>If boiler won't run & you suspect "underfire", check if adjusting screw is topped out. Turn screw clockwise in 1/4 turn intervals to increase flow rate. After each adjustment replace pressure regulator cap before turning "ON" boiler.</p>
		<p>"O-Ring" seal on regulator cap must fit securely against valve when operating boiler. Replace old/worn O-Ring if necessary.</p>

B. IF FAN PRESSURE MEASURES “ABOVE - NORMAL” CONDITIONS:
 +2.4" W.C. OR HIGHER ON AM-100 & -150
 +1.6" W.C. OR HIGHER ON AM-300

POSSIBLE CAUSE	VERIFICATION	SOLUTION
Blocked Condensate Drain	Remove condensate drain tube at rear base of boiler. Remove the fitting & insert a wire into tapping to clear debris from drain hole. Wire must be inserted a minimum 3" thru fitting to clear inside wall.	If condensate begins to flow continuously wait for flow to stop - clean tapping and/or fitting thoroughly. Reassemble drain system & check fan pressure. If fan pressure reading is “normal” range, proceed to attempt to start boiler.
		If no unusual condensate flow - proceed with check.
Blocked Exhaust Line	Check for a blockage in the exhaust line. Turn the boiler OFF. Attach a manometer to the condensate drain fitting of the boiler. Turn the Gas Valve Top Knob OFF and the boiler Rocker Switch ON. Observe the fan pressure at the condensate drain (ECC chamber pressure) .	If the measured pressure remains above “normal” and there is a muffler in the exhaust line, proceed to “BLOCKED MUFFLER” check. If no muffler, examine exhaust line and terminal for blockage.
		On the AM-150 only If the pressure is 0.2" W.C. or less, recheck the fan pressure at electrical box tee. If the fan pressure remains high proceed with check.
Blocked Muffler	Cut exhaust line after the muffler, allow at least 2" of pipe on each side of the cut for reassembly. Restart boiler and measure the fan pressure at the condensate drain fitting.	If the pressure is still “ABOVE-NORMAL” the muffler is blocked - cut it out-confirm blockage and replace it.
		If the pressure is 0.2" W.C., or less, the muffler is ok. Check the exhaust line & vent terminal for a blockage.
Exhaust Cushion Chamber (ECC) AM-150 Only	Cut exhaust line as close to boiler as possible (2" from fitting). Check fan pressure at condensate drain fitting. NOTE: Rejoin/reseal any exhaust piping cuts made by check procedures. Return Top Knob of Gas Valve to “ON” position.	If fan pressure returns to normal ECC is ok.
		If pressure remains “ABOVE-NORMAL” & no water is found in vent line, back flush the ECC to remove any blockage from the ECC muffler tube. Remove ECC and clear obstruction if back flush does not correct blockage.

CONDITION #2 continued.....

C. IF FAN PRESSURE MEASURES “BELOW-NORMAL” CONDITIONS:

- LESS THAN 1.45" W.C. ON AM-100 & -150
- LESS THAN 1.0" W.C. ON AM-300

POSSIBLE CAUSE	VERIFICATION	SOLUTION
Air Inlet Pipes/Fan Assembly (AM-100 & -150 Only)	Turn “OFF” Rocker Switch. Turn gas valve top knob OFF. Remove lid from ACC. Turn Rocker Switch “ON” and hold fan assembly firmly in place in its typical mounting position. Observe fan pressure (see “Procedures” section - “FAN PRESSURE.”)	If fan pressure increases to normal range, check the inlet piping, inlet muffler & inlet vent terminal for obstruction.
		If fan pressure remains the same, repair or replace fan assembly. If ok - proceed with check.
Obstructed or Loose Blower Wheel (AM-300)	Turn Rocker Switch and Gas Valve top knob OFF. Remove Air Cushion Chamber cover. Remove fan from mounting studs & check blower wheel is secure on shaft, not rubbing against housing & free from obstruction.	If loose, secure blower wheel properly on shaft. Remove obstructions. If ok proceed with check.
Fan Assembly (AM-300)	Hold fan assembly in typical mounting position & turn Rocker Switch ON (gas OFF). Observe fan operation and direction of rotation. (DO NOT LUBRICATE MOTOR).	If motor runs ok - check for inlet vent restriction including inlet air orifice located in inlet adapter on AM-300. See FIG.7.
		If motor runs slowly, replace assembly.
Fan Inlet Gasket (AM-100 & -150 only)	Check for compression marks on gasket for complete seal to air inlet adapter & that gasket seals completely (360-degrees) around fan inlet opening.	If gasket is not sealed properly, replace it. See “Procedure” section in this manual for details.

CONDITION 3 - BOILER IS SHORT-CYCLING

Boiler ignition occurs, strong start but runs only short time (red and green lights on) and then suddenly stops. If lights are operational, observe lights as detailed below and follow appropriate procedures.

- IF BOTH RED & GREEN LIGHTS GO OUT WHEN BOILER STOPS, BOILER IS RESPONDING TO AN OPERATIONAL CONTROL THAT IS SATISFIED. CHECK SET POINTS ON HI-LIMIT, CIRCULATOR, THERMOSTAT AND OTHER BOILER CONTROLS. ADJUST AS NECESSARY.
- IF GREEN LIGHT GOES OFF WITHIN SECONDS AFTER BOILER STOPS; RED LIGHT STAYS ON; AND BOILER DOES NOT RESTART. PROCEED WITH (3B) CHECK BELOW.
- IF GREEN LIGHT GOES OFF WITHIN SECONDS AFTER BOILER STOPS; RED LIGHT STAYS ON; BUT BOILER IMMEDIATELY RESTARTS, PROBLEM IS COMBUSTION RELATED. PROCEED WITH OPERATIONAL CHECK BELOW (3A).

CONDITION 3A - BOILER SHORT CYCLES BUT AUTOMATICALLY RESTARTS

POSSIBLE CAUSE	VERIFICATION	SOLUTION
Recirculation of Exhaust at Inlet Terminals	Visually check air inlet terminal(s) for exhaust recirculation (vapor path). NOTE: On thru-the-wall installations the exhaust should extend a minimum 12" beyond the inlet terminal.	If there is recirculation, temporarily extend exhaust vent. If this eliminates problem, proceed with permanent fix.
	If no recirculation proceed with trouble shooting procedures.	
Recirculation of Exhaust - Internal	Turn Rocker Switch & Gas Valve top knob to OFF. Remove lid from Air Cushion Chamber (ACC). On AM-100 & -150 remove the fan assembly. Remove the gas Cushion Chamber (GCC) & check the bottom of the valve plate. GCC valve discs must move freely and not bind.	(1) If valve discs have torn edges or holes - replace discs. (2) If foreign particles are between valve plate & valve retaining plate, remove them. (3) If valve discs are missing, replace them. (4) If valve discs are "wrinkled" and stiff - replace them and check condensate drain and exhaust line for partial blockage.
	Check GCC gasket for crimps or carbon trails.	If crimps, carbon trails, replace gasket following instructions with replacement. If ok, proceed with verification.
Recirculation of Exhaust - Internal (AM-300 Only)	With GCC removed, remove combustion chamber inlet (flame trap assembly). Check if O-ring between Combustion Chamber & inlet is intact. Check mating surfaces of inlet and combustion chamber. These must be clean and free of debris before re-assembly.	If O-ring has burned, hardened or has decomposed sections, check adjoining chamber and chamber inlet surfaces for obstructions which may prevent flush mating of the two surfaces. Remove any obstructions, clean O-ring groove and replace O-ring. (See "Procedures" section). If O-ring is ok proceed with trouble-shooting procedures.
Flame Trap (LP Boilers) (AM-100 & -150 Only)	With GCC removed, check that flame trap seats properly (no movement or rocking). Corrugated strips should be flush with flange face (not coned) and show no signs of "burn by" (no gaps/spaces).	If any problems are evident, correct or replace the flame trap. If in doubt, replace flame trap and run boiler to see if problem is corrected. If ok, proceed with checkout.

CONDITION #3A continued ...

POSSIBLE CAUSE	VERIFICATION	SOLUTION
Overfire	Reassemble boiler. Check input to boiler using one of the prescribed methods under "Procedures" section of the manual. Gas Valve regulator cap (with O-ring gasket) and vent line tubing (1/8" O.D. copper) must be securely connected at gas valve terminations.	If overfired-adjust input - see "Procedures" Section. If obtaining rate is difficult or starts are adversely affected, check that vent line tubing (1/8"O.D. copper) from gas valve is ok. To check: remove from regulator, connect to a manometer. Record fan pressure during purge cycle. If no - reading, check connections & blow line clear.
		If ok and boiler is installed 3 years or more, consider replacing gas valve regulator.*
		If "on rate" - proceed with checkout.
Condensate Traps in Exhaust Vent Piping (Boiler has a one to two second beat after starting)	Check for accumulation of condensate in low points of exhaust vent pipe.	Eliminate potential for any low points in exhaust piping or provide auxiliary condensate traps. Correct any short-cycling conditions which prevent normal drainage.

*Circa 1994 boiler and later are equipped with gas valves which **do not** have replaceable regulators. These 5-yr tune up kits do not include a replacement regulator.

CONDITION 3B - BOILER SHORT CYCLES BUT DOES NOT RESTART

- IF GREEN LIGHT GOES OFF BOILER STOPS & RED LIGHT STAYS ON BUT BOILER **DOES NOT** RESTART.

POSSIBLE CAUSE	VERIFICATION	SOLUTION
Wire Connections	Check for loose wire/connections at Ignition Control Module (including ground terminals); Gas Valve; Hi-limit & Combustion Prove Pressure Switch (PS1).	Tighten or correct loose connections.
		Check that GC-4A ground wire shares common ground with transformer secondary.
		Isolate and secure ignition cable from contact with all other 24V and 115V wiring. NOTE: Use only approved resistive spark plugs w/GC-4A control.
Pressure Switch (PS1) (Combustion Prove Switch)	Turn Rocker Switch & Gas Valve top knob to ON. Immediately after boiler starts, place jumper across PS1 Pressure Switch terminal (R-W). DO NOT PUT JUMPER ON UNTIL GAS VALVE IS ENERGIZED. CAUTION: TERMINAL VOLTAGE EXCEEDS 300 VOLTS. (Remove jumper after test).	If boiler stops short cycling, - replace pressure switch.
		If boiler continues to short cycle - replace ignition control module following instructions packaged with replacement. Check and verify proper module grounding.

CONDITION 4 - BOILER AND CONDENSATE WATER LEAKS

- WATER IN BASE PAN (AM-100 & -150)

POSSIBLE CAUSE	VERIFICATION	SOLUTION
Condensate Drain Fitting and Tubing	Check for moisture at bottom side of fitting and tubing.	If wet, remove tubing and fitting. Inspect and repair or replace as required.
Exhaust Vent Adapter	Check bottom of adapter connection to Exhaust Cushion Chamber (ECC) for wetness. If wet, check exhaust chamber wall around adapter for cracks. Also check vent line connection joint for wetness. NOTE: Do not over-tighten threaded plastic piping.	If wet at adapter to chamber connection, cut the exhaust line at least 2" from adapter. Unscrew adapter from chamber. Check (a) adapter for cracks and leaks - replace if necessary. If socket to chamber joint is source of leak, replace chamber see "Procedures" section . If threaded connections for leak is source, clean or replace adapter, pipe dope threads and reassemble. Reconnect exhaust to boiler.
Drain Valve	Remove ASME cover plate and inspect drain valve and bushing attachment for wetness.	Tighten or replace as required.
Pipe Connections	Check supply/return water connections to boiler.	Tighten or replace as necessary.
"O" Ring - ECC	Remove lower jacket panel. Check at assembly of boiler to exhaust chamber for signs of leakage.	If leaking, disconnect the exhaust chamber and replace the "O"-ring See "Servicing" instructions.
Cracked Exhaust Chamber	With the jacket removed, check the wall of the exhaust chamber for cracks.	If wall is cracked and shows signs of leaking - replace chamber - see "Servicing" instructions.

- WATER ON FLOOR IN FRONT OF BOILER (AM-300 ONLY)
- REMOVE LOWER FRONT JACKET PANEL AND CHECK:

POSSIBLE CAUSE	VERIFICATION	SOLUTION
Drain Plug (on bottom head of heat exchanger)	Check for loose drain plug.	Tighten, or replace drain plug.
Drain Valve (at bottom left front plate)	Check drain valve and bushing connections for signs of leakage.	Tighten or replace as required.
Dresser Elbow Seals	Check for leak at nuts on 90° Dresser elbow.	Tighten nut. If still leaking replace both seals and nipple following instructions packaged with replacement.
Nipple (at threaded fitting on bottom head)	Check nipple at attachment to boiler.	Tighten, or replace nipple.

CONDITION #4 continued ...

• WATER ON FLOOR AT REAR OF BOILER (AM-300)

POSSIBLE CAUSE	VERIFICATION	SOLUTION
Condensate Fitting & Tubing	Check condensate fitting & tubing.	Tighten, or replace fitting/tubing.
Flue Box Gasket	Check for moisture at flue box attachment to rear plate on economizer.	If wet, replace gasket following packaged instructions.
Flue Box Adapter	Check for moisture at flue pipe connection to flue box. If wet, check for condensate drainage above flue box.	If joint/vent pipe has leak, repair it.
		If leaking at flue box adapter, see "Procedures" section of this manual under "Repairing Flue Box Adaptor".
Flue Box	Check flue box for cracks & holes.	If crack/holes, replace flue box (with or without adapter) following instructions pack - packaged with replacement.
Pipe Attachments	Check Supply/Return water, Relief Valve and Hi-limit connections.	Tighten or replace components as necessary. Relief valve discharge should be piped to floor drain.

• CONDENSATE DRAINS AFTER BOILER SHUTS OFF

NOTE: It is not unusual for condensate to drain from boiler for several minutes (maximum of 15 minutes), after boiler shuts down. Amount of condensate depends chiefly on boiler operating conditions, however, flue configuration and ambient conditions, are all factors in the amount of condensate accumulated in the flue box and the drainage rate from exhaust piping systems.

POSSIBLE CAUSE	VERIFICATION	SOLUTION
Boiler Leak	(1) Pressurize boiler, bank of boilers or system as determined by installation, to its normal operating pressure. (2) Turn power OFF & close return & supply valves of boiler/banks of boilers; or shut-off system automatic & manual fill valves. (3) Observe boiler or system pressure during a 15-20 minute OFF period.	If pressure remains same & flow from condensate drain ceases, boiler is ok.
		If pressure drops & flow from condensate drain continues, there is boiler leak. Disassemble boiler, per "Servicing" instructions described in this manual, pinpoint leak and replace leaking components.

CONDITION 5 - BOILER NOISE - CONTROL AND ADJUSTMENTS

A certain amount of operational noise is to be considered "NORMAL" when operating a PULSE BOILER. Most "objectionable" noise occurs on start-up and is correctable by the procedures outlined in this section.

NORMAL OPERATION:

START-UP CHARACTERISTICS:

- Typically smooth/rapid ignition during initial ignition period, (1-2 seconds to establish operation).
- Start-up may include occasional "Stutter" (or "Puff" or "Pulse") but, boiler quickly adjusts to a balanced steady-state operation.

STEADY-STATE OPERATION:

- Produces an audible but steady "Hum" (like a muted motor sound) when listening closely at exhaust terminal.

"OBJECTIONABLE" NOISE:

START-UP CHARACTERISTICS:

- Typically requires adjustment or changes to the boiler installation. If uncorrected may cause unusual wear of boiler parts which also affect noise.
- Usually caused by "Delay" or "Dislocation" (fuel rich/fuel poor) of sustained ignition during start-up. Ignition may correct itself or system may "Snuff-out" and retry (unsuccessful ignition). This is often characterized by "Thud(s)" / "Thump(s)" / "Pop(s)" / "Crack(s)" depending on severity of condition.

STEADY-STATE OPERATION:

- Sound/frequency levels produced at exhaust terminals or transmitted to structure (via piping, etc.), are minimized by conforming to installation criteria/proper boiler adjustment/and trying exhaust changes.

CONDITION 5a - PROLONGED "STUTTER" ON START-UP (AM-300)

- An occasional stutter when starting can be expected (i.e. - cold water/initial start-up.)

POSSIBLE CAUSE	VERIFICATION	SOLUTION
Incorrect Gas Supply Pressure (should be between 4.5" to 7.0" W.C.)	Check Gas Supply Pressure and gas input rate as outlined under "Procedures" section of this manual.	Adjust Gas Supply Pressure as necessary. A supply regulator may be required. Supply pressure to boiler to be 4.5 - 7.0" W.C. running. Adjust input rate per procedure.
Low Fan Pressure (less than 1.0"W.C.)	Turn Rocker Switch & Gas Valve top knob to "OFF". Remove ACC cover. Remove fan from mounting studs & check for compression marks on fan inlet gasket for complete seal to air inlet adapter. Gasket is to fit completely (360-degrees) around fan inlet opening.	If gasket not seated properly - replace it. Follow "Procedures" section in this manual.
	Check air inlet terminal for restriction.	If gasket is seated properly, proceed with check.
		If restricted - remove restriction. If no restriction proceed with verification.
Loose or Restricted Air Inlet Orifice	Check that air inlet orifice (inside air inlet adapter) is intact & not loose or broken. Drain hole must be clear. See "Procedures" section (Fig. 7) for detail.	If air inlet orifice is loose, repair it. Follow "Disassembling AM-300" procedure described in this manual.
	Check for restriction in air inlet orifice.	If air inlet orifice is broken, replace air inlet adapter.
		Remove any restriction(s).
Valve Discs	Remove Gas Cushion Chamber (GCC) & check bottom of valve plate. GCC valve discs must move freely and not bind. Reinstall boiler parts when completed.	1. If valve discs have torn edges or holes - replace discs. 2. If foreign particles are between valve plate & valve retaining plate- remove them. 3. If valve discs are missing, stiff or "wrinkled" replace them.
Long Horizontal Vent Piping with Minimal Pitch	Check that all vent piping runs are pitched (minimum of 1/4" per foot) from vent terminal back to boiler.	Correct pitch of vent piping runs to prevent condensate blockage of exhaust / inlet piping.
Condensate Trapped in Exhaust Vent Piping	Check for accumulation of condensate in low points of exhaust vent piping.	Eliminate low points in exhaust piping or provide auxiliary condensate drain taps. (1/2" dia. max.)
Improperly Sized Vent Piping	Check that all vent piping is specified Schedule 40; (not Schedule 80) and maximum number of elbows and vent length is not exceeded.	If incorrect, change vent piping.

CONDITION 5b - COMBUSTION / OPERATING NOISE (STEADY-STATE)

POSSIBLE CAUSE	VERIFICATION	SOLUTION
Boiler Overfired	Check gas supply pressure and gas input rate as described in "Procedures" section of this manual.	Adjust supply pressure and/or input rate as necessary. If boiler is in operation more than 5 years - it is recommended to install a tune-up kit.
"ACC" to Boiler Gasket	Place your ear against the boiler jacket approx. 14" from top. Circle the boiler. Check for uniform sound for uniform sound level.	If sound level is not uniform, a gasket leak may be suspect. With the lid removed visually check the gasket from inside the ACC - at the boiler/ACC seam. (Remove the insulation from the side wall prior to visualcheck-AM-300). If a gap is identified, fill with silicon. See "Procedures" section if gasket replacement is required.
Insulation between Top Jacket Access Panel & Air Cushion Chamber (A.C.C.) Lid	Remove jacket top cover & check that insulation is in place.	Adjust as necessary.
A.C.C. Lid & Gasket	Turn Rocker Switch & gas valve top knob "OFF." Check if lid is securely fastened. Remove "ACC" lid. Check gasket between "ACC" & lid is intact.	If gasket has gaps, tears, etc., replace entire gasket. If nuts securing lid are loose, tighten them.
Valve Discs (G.C.C.)	Remove Gas Cushion Chamber (GCC) and inspect bottom of valve plate. [Remove fan assembly (AM-100/-150 only) to get access to (GCC)]. Valve discs must move freely & not bind.	<ol style="list-style-type: none"> 1. If valve discs have torn edges or holes - replace discs. 2. If foreign particles are between valve plate & valve retaining plate - remove them. 3. If valve discs are missing; "wrinkled" or "stiff" - replace them. Check condensate drain/exhaust lines for partial blockage.
Combustion Chamber Inlet (Flame Trap Assy). (Replacement Gaskets required)	<p>Remove and check that inlet is flat & not coned in either direction.</p> <p>Reassemble boiler when completed.</p>	If coned, remove inlet & carefully align corrugation edges. DO NOT DISTORT. (Check O-ring). AM-100/-150 flame trap assy. is a replacement part.

CONDITION 5c - VIBRATION NOISE (IN-HOUSE) BUT, REMOTE FROM BOILER (STEADY-STATE)

POSSIBLE CAUSE	VERIFICATION	SOLUTION
Air Intake & Exhaust Lines	Visually check that the lines are supported with vibration isolator supports & the lines are isolated from the building structure - especially where exiting the building or passing thru walls.	If pipes are rigidly supported or in direct contact with the building structure, change the supports to vibration isolators or re-route the piping as required. See Installation Manual (AM2).

CONDITION 5d - "OBJECTIONABLE" EXHAUST NOISE (MUFFLERS INSTALLED)

CONDITION	VERIFICATION	SOLUTION
Exhaust Noise When Boiler Runs	Add a one foot extension to the exhaust termination (remove after check). Exhaust piping CPVC (SCH-40) length should not exceed installation limitations. NOTE: Thru-the -wall exhaust terminals require a 12" extension to begin with.	If there is a perceptable noise reduction permanently attach the one foot extension you have added. The sound you are hearing may be the normal operating sound of the boiler. Check with Customer Service for additional options in noise reduction
- Dull-"Thud" or "Pop" on Start-up. - Sharp-"Crack" on Start-up. (AM-300)	Check for high gas supply pressure per "Procedures" section in this manual (typical 4.5 - 7.0" W.C.). If re-adjusted a lowside gas pressure is preferred. NOTE: If boiler is more than 5 yrs old - consider tune-up kit installation.	If inlet gas supply pressure exceeds 7" W.C. install a "lock-up" style supply pressure regulator as close to boiler as possible. Set this regulator at 4.5 to 5" W.C. delivery pressure when running. Recheck gas input rate per procedure. If problem persists call Customer Service for a "Hard Start" kit.

CONDITION 5e - OBJECTIONABLE (LOCALIZED) NOISE - STEADY-STATE

POSSIBLE CAUSE	VERIFICATION	SOLUTION
Exhaust Line Leak	Check exhaust vent line, joints & connections to boiler.	Repair or replace as necessary with "SCH-40" CPVC parts.
"O" Ring between Boiler & Exhaust Cushion Chamber (ECC) (AM-100/-150)	With the boiler running for 5-minutes; feel around the jacket about 3" below the lower jacket panel seam for "hot spots". This is an indication of internal gasket leakage.	If a leak is suspect, remove lower jacket panel. Restart boiler and locate exhaust leak.
		If confirmed - replace "O" ring. See replacement instructions under "Procedures" section. Replace jacket panel.
Gasket between Boiler & Economizer (AM-300)	With the boiler running for 5-minutes, check boiler sides/rear about 15" from jacket bottom for noise or hot spots (as opposed to other areas). NOTE: Remove the top access panel. If there is moisture on top insulation or on top of A.C.C., a gasket leak is probable. To check for noise at boiler front, remove lower front panel.	If noise/hot spot is suspect, remove jacket & insulation. Check gasket for leaks. If leaking, replace gasket following instructions packaged with replacement.
		If noise/hot spot is not confirmed, proceed with verification.
Flue Box-To-Economizer Gasket (AM-300)	Check if gasket is deteriorated or blown out.	If deteriorated or blown out, replace gasket following instructions packaged with replacement.

SECTION 3: SERVICING & REPAIR PROCEDURES

SERVICING TOOLS LIST:

- Volt/OHM/Continuity Meter
- 15/16" Deep Socket
- Breaker Bar (Spark Plug Removal).
- 48" U-Tube Manometer (not magnahelic or dial type)
- 3/16" I.D. Manometer Tubing
- 3/16" O.D. x 5" long - Copper Tubing
- Zinc Rich - Cold Galv. compound
- 3/16" Hose Barb - Tee
- 3/16" O.D. Tubing Compression Tee (w/fittings)
- (2) 1/8" NPT X 3/16" Hose-Barb Fittings
- Stop Watch/Sandpaper (fine)
- Replacement gaskets/O-rings
- Exhaust/Inlet (CPVC) cement
- Wire Brush
- RTV (Hi-Temp) Caulk
- Assorted Wrenches and Screw Drivers

FAN PRESSURE CHECK - [AM-100 and 150]

1. Turn boiler OFF.
2. Remove the compression union on the copper combustion pressure sensing line located in the electric box.
3. Replace the union with the compression tee. Connect a piece of 3/16" copper tube to the open port on the tee.
4. Connect a piece of rubber hose from the copper tube to one side (either side) of the manometer.
5. Turn the boiler ON and allow about 20 seconds for the fan to get up to speed. Take the fan pressure reading before ignition starts. Remember, read both sides of manometer and add values together for total water column reading (figure 6).

Normal fan pressure is +1.5 to +1.9" W.C.
Min. to close Fan Prove Switch (PS2): +1.1" W.C.
Blocked exhaust line pressure is +3.3" W.C.

6. Approximately 35 seconds after turning the boiler ON, the boiler will attempt ignition. When combustion starts, the manometer will read the combustion pressure.
7. When finished - turn boiler "OFF" and remove the pressure tap from the pressure sensing line and reinstall the original fittings.

FAN PRESSURE CHECK - [AM-300]

1. Turn boiler/Rocker Switch and gas valve top knob "OFF."

2. Locate the plastic tube connecting the Fan Prove Pressure Switch (PS2) to the 3/16" barb tee on the boiler. Disconnect the plastic tubing from either the pressure switch or the tee and insert tubing into one leg of your barb tee.
3. Insert your short piece of tubing between another leg of your tee and the pressure switch or boiler barb tee (from which the tubing was originally disconnected).
4. Connect your other piece of tubing from the open end of your tee to one side (either side) of the manometer.
5. Turn boiler ON and allow about 10 seconds for the fan to come up to speed. Read fan pressure.

Normal Pressure: +1.0 to +1.4" W.C.
Min.to close Fan Prove Switch (PS2): +0.6" W.C.
Blocked Exhaust Pressure: +1.9" W.C.

6. When finished - turn boiler "OFF." Remove test equipment - restore to operational status.

GAS SUPPLY PRESSURE CHECK (ALL MODELS):

1. Turn boiler "OFF." Turn gas supply to combination gas valve OFF at the upstream service valve. Turn off all other appliances utilizing the same gas supply regulator.
2. Remove the line pressure test plug (inlet pressure tap) on the combination gas valve and insert your manometer adaptor (see fig 4).
3. Connect your piece of tubing from the adaptor to one side (either side) of the manometer.
4. IF IGNITION CANNOT BE SUSTAINED, open the service valve and take your readings right away. Remember, you must add the two manometer water columns together (figure 6).
5. IF IGNITION CAN BE SUSTAINED, open the service valve and turn boiler ON. Take your readings after combustion starts. Remember, you must add the two manometer water columns together (figure 6).
6. Gas supply pressure must be between 4.5" W.C. and 7" W.C. for natural gas or 11" W.C. for propane. Adjust if necessary when boiler gas valve is energized.

- Turn the gas supply "OFF" at the up-stream service valve before replacing the line pressure test plug on the combination gas valve.

**INPUT RATE: METHOD #1 -
METERED INPUT (Gas Meter Required.)**

Gas supply pressure should be checked (per procedure) before beginning this section.

- Turn OFF all appliances and equipment served by gas meter, including gas stove, pilot lights and gas yard lights. In addition, before calculating the input of the boiler, obtain the heating value of the gas from the local utility.
- Operate boiler for at least 10 minutes to assure that measurements are accurate. Using a stopwatch measure the time in seconds it takes for the boiler to use 10 cubic feet of gas at meter.
- Divide 36,000 by the number of seconds for 10 cubic feet of gas used.
- Multiply that number by the heating value of the gas to obtain the Btu input per hour.

EXAMPLE: An AM-300 boiler takes 120 seconds to use 10 cubic feet of natural gas. The local utility indicated the heating value of the natural gas being supplied is 1000 Btu/cu.ft.

Therefore:

$$\frac{36,000 \times 1000}{120} = 300,000 \text{ Btu input per hour}$$

Boiler input (within 2% of nameplate) is correct. For installations at altitudes above 2,000 ft. - derate in accordance with code practices.

**INPUT RATE: METHOD #2 -
DIFFERENTIAL PRESSURE (DELTA P) -
Use this procedure if no gas meter is provided.**

- Turn boiler and gas valve top knob OFF.
- Remove plug from manifold pressure tap in gas line downstream from combination gas valve and insert one of your adaptors. Connect one piece of your tubing from the adaptor to one side (either side) of the manometer.
- Remove outlet pressure tap test plug from combination gas valve (see fig. 4 and 5) and insert your other adaptor. Connect your other piece of tubing from the adaptor to the open side of the manometer.

- Turn Rocker Switch and Gas Valve top knob to ON. Approximately 30 seconds after combustion starts, manometer should read according to TABLE 1 below. Adjust input rate if necessary. Remember to read both sides of a manometer and add values together for total water column reading (figure 6).

TABLE 1

Model No.	Gas	(0-2000 ft.) Delta-P Pressure	10% Derate High Altitude Delta-P Setting
AM-100	NAT	2.8 W.C.	2.3
AM-100	LP	4.5" W.C.	3.7
AM-150	NAT	2.1" W.C.	1.8
AM-150	LP	6.8" W.C.	5.6
AM-300	NAT	1.6" W.C.	1.3

ADJUSTING INPUT RATE

- To adjust the input rate turn boiler OFF and remove the extended regulator adjustment cap (with "O-ring seal) on combination gas valve pressure regulator. This exposes the regulator adjusting screw (see fig. 4).
- Turn adjusting screw clockwise to increase the manometer pressure (increase input). Turn adjusting screw counterclockwise to decrease manometer pressure (decrease input) - DO NOT ADJUST MORE THAN PLUS/MINUS 1/4 TURN WITHOUT RECHECKING PRESSURE.
- IMPORTANT: Replace cap on adjusting screw (tightly secured) and turn boiler ON to check pressure. Final differential pressure setting should not vary more than plus/minus 0.2" W.C. from table value. Repeat this adjustment procedure until desired setting is obtained taking pressure readings after ignition has been established (30 seconds).

FLUE BOX ADAPTOR REPAIR - [AM-300].

Also may require an oil filter type wrench and a replacement gasket (follow instructions packaged with replacement). Refer to fig. 12.

- Remove the eight (8) nuts and washers holding flue box to the rear of boiler and pull flue box away from boiler.
- Inside the flue box, loosen the nut holding the CPVC adaptor to the flue box with the oil filter type wrench. Separate the adaptor/exhaust line from the flue box.
- Clean the bottom portion of the CPVC adaptor (that's in contact with the flue box) of any old silicone material.

4. Apply a 1/4" wide bead of silicone at the edge and completely around the 3-1/2" diameter hole in the top of the flue box. Allow silicone to skim.
5. Assemble the CPVC adaptor/exhaust line to flue box and thread the nut on the adaptor until the nut is snug.
6. Apply a 1/4" wide continuous bead of silicone to gasketed edge of the flue box. Allow silicone to skim.
7. Position the flue box against the rear of the boiler. Secure in position with the eight (8) nuts and washers which were removed. Do not over tighten.
5. Secure orifice in place with PVC cement. Replace fan assembly in boiler. Reassemble boiler lid and panel and turn gas "ON". Restart boiler after cement has cured.

IGNITION WIRE CHECK

Turn Rocker Switch and Gas Valve top knob to "OFF." Place a jumper across the fan prove pressure switch (PS2) terminals. Remove the cover from the Air Cushion Chamber (ACC). On the AM-100 & -150, remove the fan blower assembly. (DO NOT disconnect motor leads). With an atomizer or wet cloth, lightly wet (don't soak) the ignition wire in the ACC with water. Turn the Rocker Switch "ON" and start the ignition sequence on the boiler. During the attempt for ignition (Green Light ON) observe the ignition lead wire for sparks. (This can be best observed in a darkened area).

If any sparks are seen - replace the ignition wire (AM-300); or wire harness (AM-100 & -150). See "PROCEDURES" section for replacement procedure.

When check is completed turn Rocker Switch OFF. Replace fan assembly, ACC cover, remove jumper from pressure switch (PS2) and turn gas valve "ON." Turn the Rocker Switch "ON" and check operation of boiler.

FAN INLET GASKET REPLACEMENT - [AM-300]

1. Turn gas and power to boiler OFF.
2. Remove top jacket access panel. Remove lid on air cushion chamber. Disconnect fan leads & remove blower assembly from mounting studs.
3. Remove the old gasket from the blower inlet and attach a new gasket without stretching it. Align the gasket with the edge of the blower inlet. Trim the excess and butt the ends to form a complete circle (connection must be leak tight).
4. If compression marks on the old gasket were not complete and concentric around the inlet, bend studs as required to obtain proper alignment between inlet and adaptor. If there is a gap between the face of the gasket and adaptor, remove spacers from studs and shorten the spacers 1/16" more than the aforementioned gap.
5. Remount the blower assembly on the mounting studs.
6. Reconnect fan leads and replace lid on air cushion chamber. Tighten nuts securely. Replace top jacket access cover.

AIR INLET ORIFICE REPAIR - [AM-300]

1. Turn gas and power to boiler "OFF." Remove top access panel and "ACC" lid. Remove fan assembly from boiler.
2. From the air cushion chamber, locate the orifice in the 3" air inlet adaptor (PVC fitting attaching air inlet vent to boiler) against which the fan assembly was mounted. (See Figure 7).
3. Remove orifice and lightly sand the orifice O.D. to remove old cement.
4. Replace the orifice in the air inlet adaptor within 3/8" of the step of the adaptor. Make sure the bevel in the orifice is away from the boiler and the small hole is at the bottom. The orifice may be slightly tilted when installed.

WIRE HARNESS ASSEMBLY REPLACEMENT [AM-100 & -150]

1. Turn power to the boiler "OFF" at electrical supply disconnect switch.
2. Before removing the electric box from jacket:
 - a. Disconnect power supply and thermostat leads from the electric box.
 - b. Disconnect the 24V leads (yellow & orange) on the gas valve. Disconnect the 1/8" O.D. copper regulator vent pressure line at the gas valve. Disconnect the 24V wires (blue & brown) from the high limit terminals.
 - c. Inside the electric box, disconnect all wires exiting the wire harness from their terminals in the box.
 - White wire at (#4) on terminal strip
 - Green wire from ground screw
 - Red wire - cut wire inside electrical box and splice later
 - Ignition wire from terminal on ignition control
 - d. Inside the electric box, disconnect the copper tubes exiting the wire harness from the plastic tubing and brass fitting respectively. Bend out and away from the electric box.
 - e. Unscrew the bushing from the end of the wire harness fitting.
3. Remove the (4) four screws securing the electric box to the jacket and lift electric box away from the boiler - set aside.

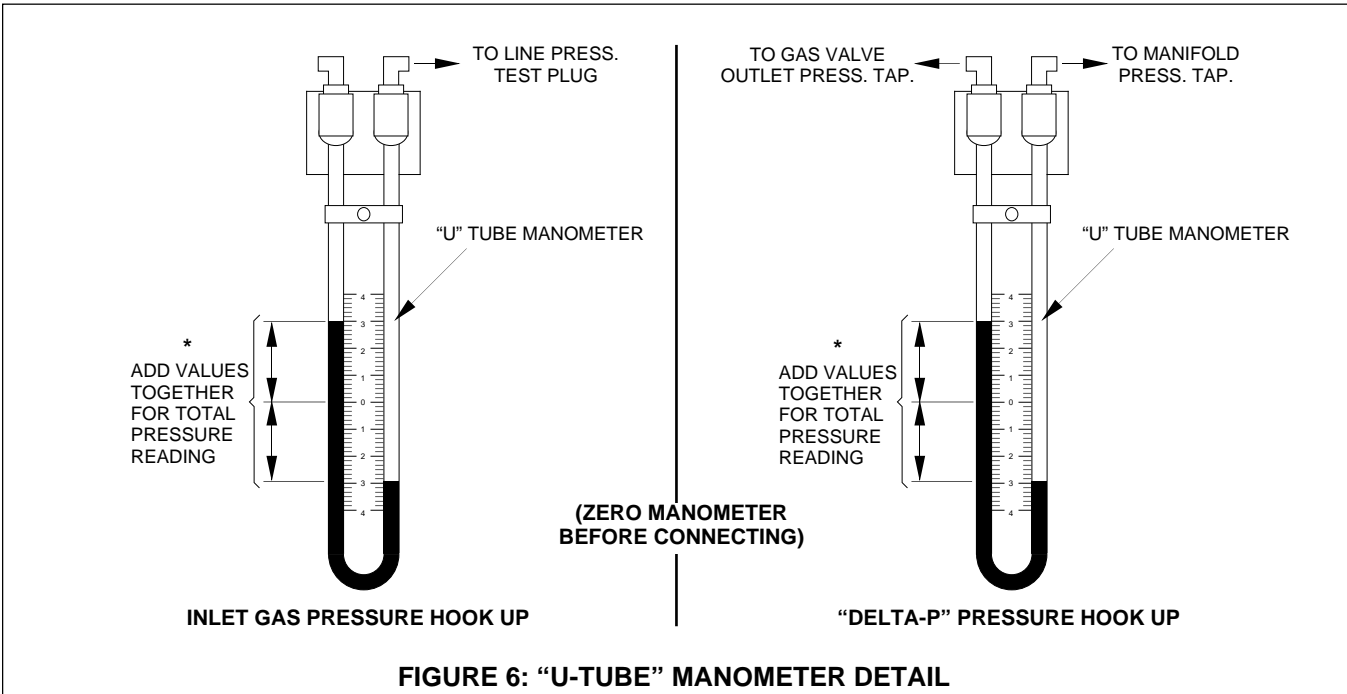
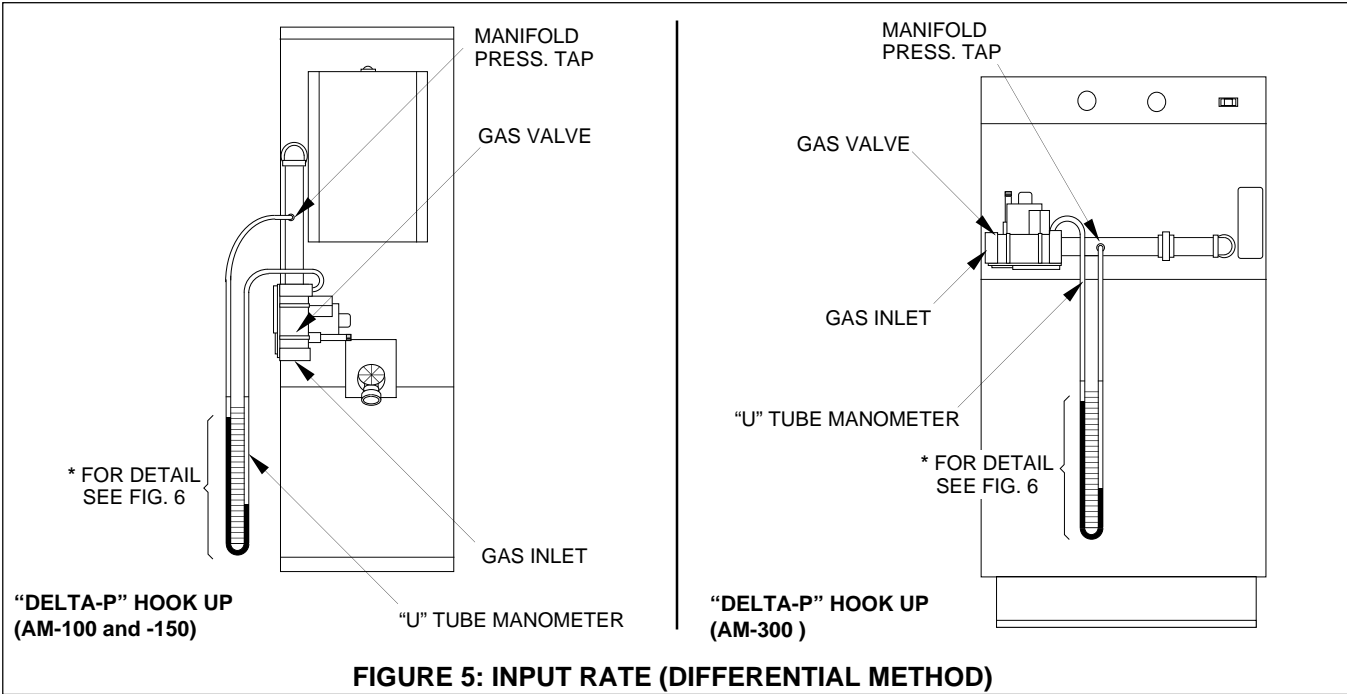
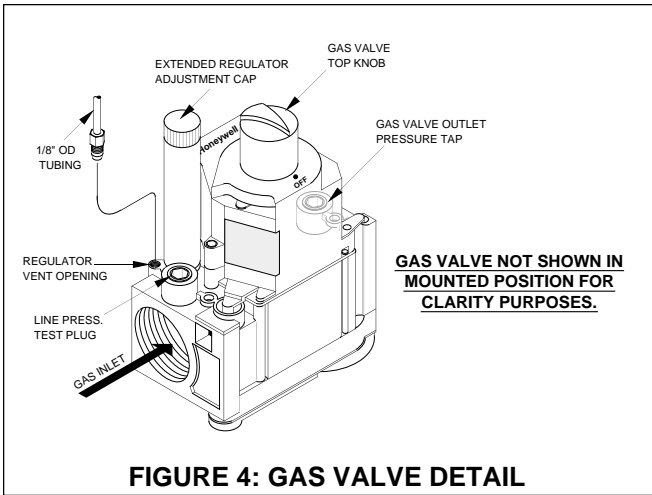

4. Remove jacket top and insulation from the boiler. Remove the Air Cushion Chamber (ACC) lid and lift out the fan assembly, taking care when disconnecting the motor leads.
5. Inside the ACC, disconnect the green ground wire and the copper tube at the union (leave union in ACC). Remove spark plug wire from spark plug.
6. Unscrew the wire harness nipple from the ACC.
7. Screw-in the new wire harness assembly making sure the long leads extend into the ACC. Reassemble all electrical and hardware pieces to boiler and reattach the electric box in the reverse order described above. Bend (DO NOT KINK) the copper tubes in the wire harness to mate with lines in ACC and electric box. Tighten copper tube connections gas tight. Check all electrical connections are secure. Splice red wire in electrical box to mating red wire (Pin #3) on 3-pin molex connector (GC-4). Keep this splice inside electrical box (NOT IN ACC). Isolate ignition wire as well as complete, restore power at electrical supply disconnect.
4. Check the bottom head of the boiler and remove any remnants of the gasket that may be adhering to it. If there is any evidence of rust on the head, scrape and wire brush to bright metal and spray with a zinc rich cold galvanize. Apply two generous coats. Allow the galvanize to dry between coats and before reassembly to the ECC.
5. If replacing the ECC, remove the old ECC from the base pan and discard it. Check the base pan. If excessively deteriorated (rusted, etc.), replace it; if satisfactory, check the 3 tabs on the bottom are pointing up at 90 degree angle - bend if required.
6. Center the new ECC in the base pan inside the three tabs. If necessary, attach the condensate drain to serve as a guide. Keeping the ECC centered in the base, rotate it to locate the condensate drain fitting exactly between two screw holes in the base pan flange.
7. *For AM150's the base section is steel and uses a poly-tape for the seal. Place the tape on the AM150 base to cover the area of the base connecting flange surface. Cut the tape as necessary and seal as needed with 1/8 bead of silicone. For the AM100 lay the poly-tape over the groove in the groove where the "O" ring used to be. Follow the step 5 above.

EXHAUST CUSHION CHAMBER (E.C.C.) AND/OR "O" RING REPLACEMENT [AM-100 & -150]

1. Drain the system and remove the boiler from the system:
 - a. Turn boiler "OFF" at electrical supply disconnect switch. Disconnect the power supply and thermostat connections at the boiler.
 - b. Turn OFF the gas at upstream gas shutoff valve and disconnect gas supply at boiler.
 - c. Disconnect the supply and return water connections.
 - d. Cut the Air Intake & Exhaust pipes as close to the boiler as possible, while leaving at least 2" of pipe on each side of the cut so that the pipe can be reconnected with a SCH-40 coupling. Unscrew the exhaust adaptor from the ECC.
 - e. Disconnect the condensate drain line.
2. Remove the lower jacket panel - remove all sheet metal screws on the horizontal seam, the base and vertical lower panel seams. Lift the loose lower jacket to free it from the base pan. (See fig. 9).
3. Remove and set aside the 3 nuts securing the boiler flange to the ECC. Lift the top portion of the boiler off of the ECC. (It may be necessary to pry the assemblies apart to break the "O" ring seal). Place the top portion of the boiler on it's side, taking care not to damage the jacket or electric box.
8. Position the top portion of the boiler on the ECC. Align the water return and supply fittings with the condensate drain and the holes in the bottom boiler flange with the ECC studs.
9. Incrementally and alternately tighten each nut to a maximum of 5 ft./lbs. (overtightening can crack the ECC).
10. Replace the lower jacket.
11. Reattach the exhaust adaptor. **Do not** overtighten.
12. Reposition the boiler; reassemble parts and reconnect to the system. Reseal inlet/exhaust vent piping. Attach water connections, purge and refill system. Restore power/gas supplies to boiler. Follow the operating instructions supplied with the boiler.

DISASSEMBLING AM-300 BOILER

NOTE: Disassembly may damage the GCC gasket, ACC gasket, fan inlet gasket, flue box gasket, dresser gasket and/or economizer gasket. See replacement parts list for part numbers. In addition, when disassembling the boiler retain all the hardware.

1. Turn gas "OFF" at supply (upstream) valve. Turn electrical power to boiler "OFF" at disconnect switch. Disconnect gas piping and power to boiler. Isolate boiler from hydronic system and drain boiler. Disconnect supply and return water piping.
2. Disconnect the exhaust vent, as follows:
 - a. Either cut the vent pipe in a straight section near the boiler (leaving a sufficient straight section on either side of this cut to rejoin later with a coupling).
 - b. Or remove the eight (8) nuts and washers holding the flue box (and exhaust line) to the boiler and pull flue box away from boiler. (See fig. 12).
3. Remove the air inlet - either cut the vent pipe in a straight section near the boiler (leaving a sufficient straight section on either side of this cut to rejoin with a coupling) or remove the air inlet as follows:
 - a. Remove top jacket access panel, insulation, and the lid to the air cushion chamber (ACC) by removing six 1/4" nuts.
 - b. Remove the two electrical power wires connected to blower motor. Remove three 1/4" nuts from blower assembly mounting studs and slide blower assembly out. Then, remove spacers from mounting studs.
 - c. From the inside of the ACC, carefully pry out the insulation from the right side wall, first. Then pry out the insulation from the rear wall of the ACC and set aside for reuse.
 - d. Remove locknut from PVC air inlet adapter by lightly tapping it (counterclockwise) with hammer and screwdriver. Then, push the adapter through the rear wall of the ACC (a light tap with a hammer may be necessary to break silicone seal between adapter shoulder and ACC rear outside wall). See fig. 7.
4. Remove the boiler from the installation and locate it for further disassembly.
5. Remove the jacket from the boiler as follows (retain all screws for reuse): Refer to fig. 12.
 - a. Remove top and front access panels.
 - b. Remove screws from upper front corner panel. Remove panel sufficiently to disconnect quick connections to rocker switch and lights. Remove panel.
 - c. Remove the lower front panel and rear upper and lower panels.
 - d. Remove the two screws from each side panel and lift the panels off the support rails.
6. Remove the Air Cushion Chamber (ACC) as follows (all these items will be reused):
 - a. Remove the lid from the ACC.
 - b. Disconnect and remove the gas supply tube from the gas pipe to the Gas Cushion Chamber (GCC).
 - c. Disconnect the pressure sensing tube from the GCC assembly.
 - d. Remove the GCC by removing the four nuts securing it to the Combustion Chamber Inlet.
 - e. Disconnect the spark plug lead from the plug.
 - f. Remove the Combustion Chamber Inlet (flame trap) by removing the four 3/16" Allen head screws securing it to the Combustion Chamber.
 - g. Check to assure the capillary tube from the hi-limit is clear of the ACC. Where the hi-limit is mounted to the ACC, remove the bulb from the well and secure the capillary tube with bulb to the ACC.
 - h. Remove the four bolts securing the ACC to the heat exchanger.
 - i. Lift off the ACC (with electric and gas controls). There may be some silicon used to seal the corners of the ACC to the heat exchanger or used on the gasket.

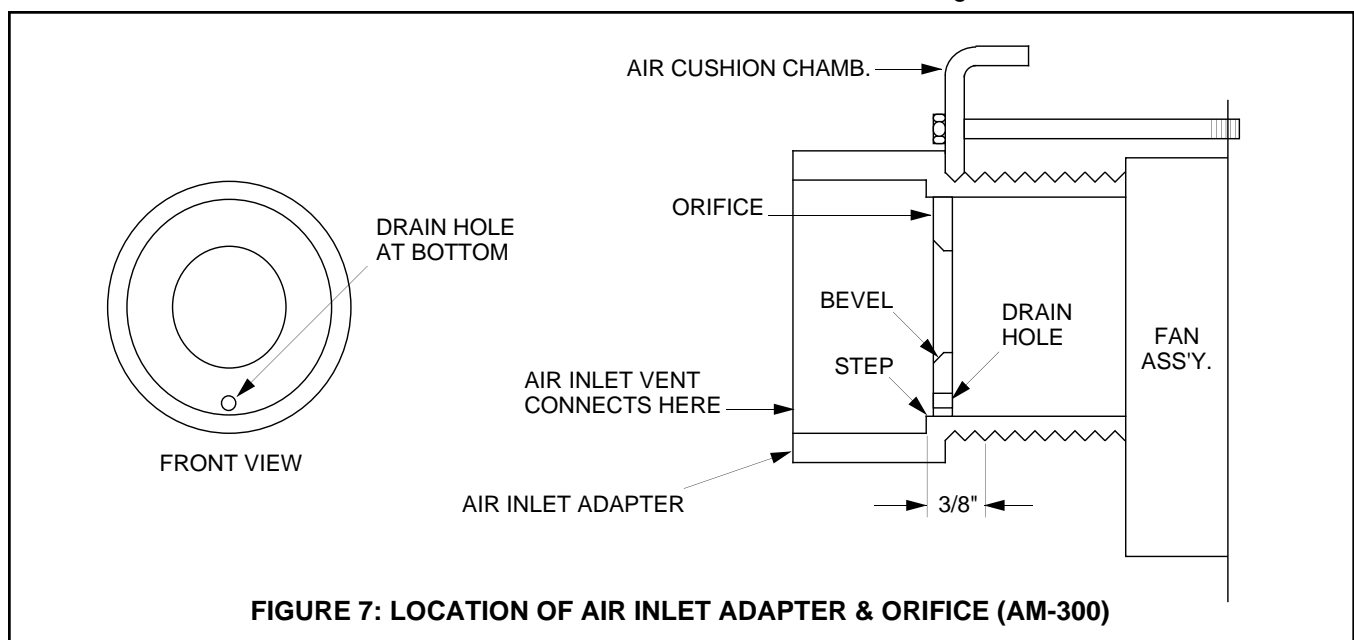

7. Remove the heat exchanger as follows:
 - a. Carefully remove the insulation from the top (front and rear) and sides of the heat exchanger. These will be reused on the new assembly.
 - b. Loosen the Dresser nut on the bottom of the heat exchanger connecting the 1-1/2" pipe nipple to the 90° Dresser elbow.
 - c. Remove the 12 bolts connecting the heat exchanger to the economizer (two in front, two in back and four on each side.)
 - d. Lift heat exchanger off the economizer and set it aside (it may be necessary to pry the two assemblies apart to break the gasket seal.)

LEAK CHECK [AM-300]

1. Pressure test the heat exchanger with water. Keep pressurized for at least an hour or until leak is spotted. The leak may be small and take a while before it becomes noticeable. If necessary to replace heat exchanger, refer to replacement parts list and follow packaged instructions.
2. Pressure test the economizer. If necessary to replace economizer, refer to replacement part list and follow packaged instructions.

REASSEMBLING AM-300 BOILER

1. Attach heat exchanger to economizer as follows:
 - a. If re-using the economizer, remove the old gasket used to seal the two assemblies from the economizer. The top of the economizer may have some accumulated rust and debris. Scrape or brush the surfaces and remove all loose dirt. If rusted, spray with zinc cold galvanized compound.

NOTICE: Extreme care should be taken in positioning gasket (step 1b) and in placing the heat exchanger (step 1f) to assure the gasket remains in position. A displaced gasket will result in a flue gas leak and noisy operation.

- b. Position new gasket on the economizer as follows:
 - (1) Starting on the front (thickest plate or thickest section of front plate) lay the gasket on the edge against the retaining plate. Lay the gasket on all four top surfaces of the economizer forming the corners so that the gasket is always on the plate. When the gasket over-laps itself miter cut at 45° to form an overlapping butt joint (see fig. 8).
 - (2) Use high temperature silicone RTV to hold the butt together and at occasional spots between the top edge of the economizer and the gasket to hold the gasket on the plate edge.

(3) Lay an approximately 4" piece of the 1/4" square braided gasket next to and overlapping the butt joint. Use high temperature silicone RTV to hold in place.

- c. Place Dresser elbow on the pipe stub of the economizer. Snug the nut and leave elbow pointing up.
- d. Connect the 1-1/2 TOE pipe nipple into bottom of the heat exchanger.
- e. Place the "Dresser" nut and gasket components on the pipe nipple. Secure these parts against the bottom head of the heat exchanger to prevent them from dropping off during handling.
- f. Pick up the heat exchanger and place it on the economizer. The pipe (step 1d) must fit into Dresser elbow on the economizer and the bolt holes in the bottom head of the heat exchanger must line up with the corresponding holes on the economizer bracket.

CAUTION: The heat exchanger must be accurately placed in position to assure the gasket is not displaced. Do not slide the heat exchanger on the gasket to align the holes. If shifting is required pick up the heat exchanger, check that the gasket is in position and repeat step (1f). Use of a "guide pin" in a hole on each side of the heat exchanger can help placement with the holes on the economizer bracket. Visually check that the gasket is in place before proceeding.

- g. Assemble the 1-1/2" nut to the Dresser elbow.
 - h. Locate the 12 bolts, nuts and washers, and snug up all nuts. Torque the nuts to 10 ft.-lbs. Then retorque all the nuts in 5 ft.-lb. increments to 25 ft.-lbs. in a staggered pattern. Tighten nuts on Dresser coupling.
 - i. Clean the top surface of the Combustion Chamber and the "O" ring groove. Position the "O" ring in the groove. Place the Combustion Chamber Inlet on the Combustion Chamber and secure with the (4) four Allen-head screws.
 - j. Wrap and secure the insulation from the old boiler around the heat exchanger.
 - k. Replace the spark plug - use an anti-seize compound on the threads.
2. Install the Air Cushion Chamber (ACC)
 - a. Observe location of, and remove old gasket from bottom flange of the ACC and install a new gasket.
 - b. Locate the ACC on the heat exchanger by aligning the holes in the ACC flange with the holes in the heat exchanger. Install the 90° angle clip, bolts, washers and nuts and tighten.
 - c. Seal openings at the outside bottom corners of the ACC with silicone caulk for an air tight seal.

3. Assemble Gas Cushion Chamber (GCC) to the Combustion Chamber Inlet. Replace the GCC gasket. Locate clamp ring and secure with 1/4" washers and nuts.
4. Attach the gas supply tube from the GCC to the gas pipe in the ACC.
5. Reconnect the pressure sensing tube on the GCC.
6. Reattach the ignition lead to the spark plug.
7. Replace lid on the ACC. NOTE: If the air inlet piping was disconnected at the ACC skip this step.
8. Replace and secure the hi-limit bulb making sure it is bottomed in the well. Carefully route the capillary tube to avoid contact with sharp edges. Place excess capillary tubing flat on the top rear head of the boiler.
9. Replace the insulation on the top head of the boiler (front and rear). Replace the jacket.
 - a. Mount the side panel bracket on the support rails at the bottom of the economizer. Align the opening in the left side panel with the gas valve.
 - b. Attach rear bottom, rear top and front bottom panels.
 - c. Before attaching the front upper panel connect the two black leads with quick connects to the Rocker Switch. Screw the front panel in place. Re-connect the red light leads (one brown and one white) and the green light leads (one orange, one white).

REPOSITION BOILER IN ITS LOCATION [AM-300]

1. If the venting was cut when the boiler was removed, reconnect the cut sections with couplings. Cement venting joints.
2. If the venting was disconnected from the boiler:
 - a. Use the new flue box gasket and follow directions supplied to reattach the flue box.
 - b. To reconnect the air inlet adapter, clean the old silicone from the ACC's inlet adapter. Apply a thin bead (approximately 3/16" wide) of silicone caulk completely around shoulder of the adapter. Insert the adapter through the opening in the ACC. Screw the locknut onto adapter, and tighten securely.
 - (1) Reinstall rear wall and right side wall insulation in the ACC (press to fit in place).
 - (2) Remove the gasket from the blower inlet and attach a new gasket without stretching it. Align the gasket with the edge of the blower inlet. Trim the excess and butt the ends to form a complete circle. Connection must be leak-tight.

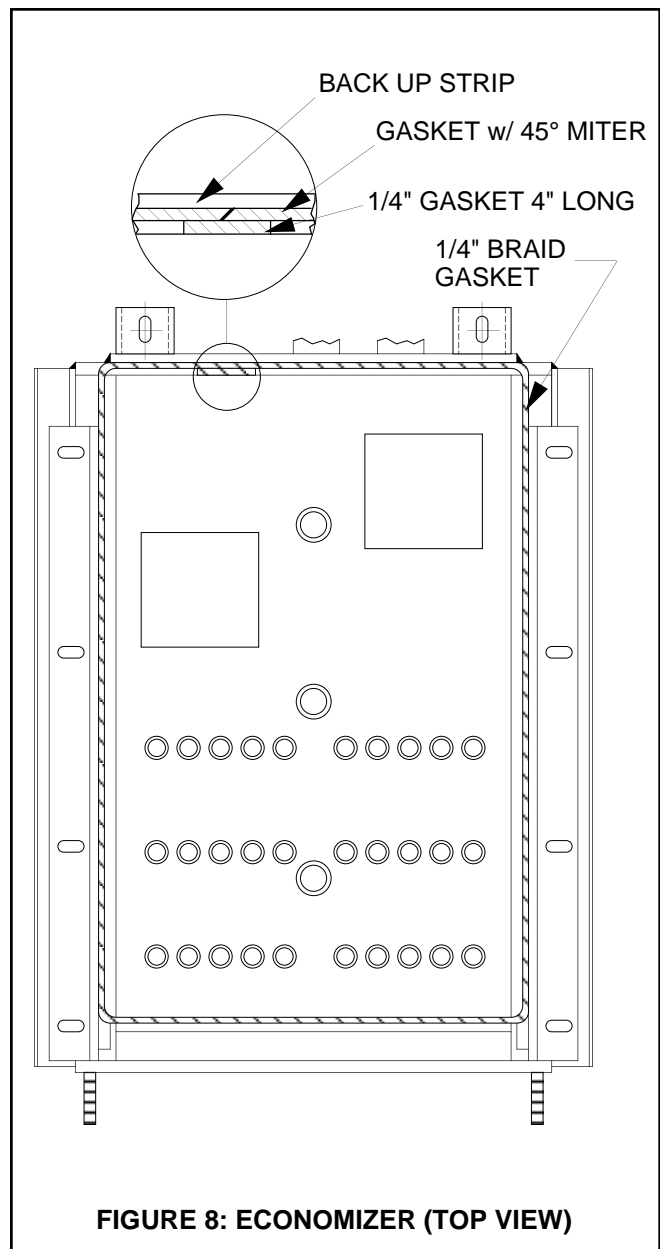

FIGURE 8: ECONOMIZER (TOP VIEW)

- (3) Replace spacers on the blower assembly mounting studs.
- (4) Check compression marks on old gasket. If the compression marks on the old gasket were not complete and concentric around the inlet, bend the studs as required to obtain proper alignment between the inlet and adapter. If there is a gap between the face of the gasket and adapter, remove spacers from the studs and shorten the spacers 1/16" more than the aforementioned gap.
- (5) Remount blower assembly on mounting studs. Reinstall blower assembly nuts and tighten securely. Reconnect power leads.
- (6) Replace lid on ACC and tighten nuts securely.

3. Reinstall boiler water, gas and electric connections.
4. Thoroughly purge the air from the boiler and system. Only after system is purged of air and filled with water should the boiler be started. Follow the recommended system start-up procedure in the installation manual.

HEAT EXCHANGER REPLACEMENT [AM-100 & 150]

1. Turn gas supply OFF at upstream supply valve. Turn electrical supply OFF at wall disconnect switch. Disconnect gas pipe, 115V power and thermostat lines at boiler.
2. Isolate boiler from hydronic system and drain boiler. Disconnect supply and return water piping and condensate drain line.
3. Cut air intake and exhaust lines leaving at least 2" on each side of the cut to receive a coupling for reassembly.
4. Remove the boiler from the installation and locate it for further disassembly.
5. Remove the electric box from the boiler:
 - a. Disconnect the yellow and orange leads from the gas valve and blue and brown leads from the high limit.
 - b. Remove the 1/8" O.D. copper regulator vent pressure line at the gas valve.
 - c. Inside the electric box, exiting the wire harness disconnect:
 1. Green ground wire from ground screw
 2. White lead from terminal #4 on terminal strip
 3. Ignition wire lead from the GC-4 ignition spud
 4. Red lead - cut wire inside electrical box and splice later.
 5. Copper pressure lines exiting the wire harness. Separate from plastic tubing and compression fitting respectively. Bend tubes straight and away from electric box.
 - d. Unscrew bushing from end of wire harness.
 - e. Remove the four screws securing box to boiler jacket and lift the box away from the boiler - set aside. (See fig. 10 and 11).
6. Disconnect the gas valve and gas lines, unscrew the air inlet and exhaust adapters, detach the high limit and unscrew the well from the boiler.
7. Remove all jacket screws and lift off the top lid and jacket parts from the boiler. (Refer to fig. 9).

8. Remove the Air Cushion Chamber (ACC)
 - a. Remove the 4-1/4" nuts securing the top lid. Lift off the lid and the spring and set them aside.
 - b. Lift the fan assembly, disconnect the motor leads. Remove assembly and set aside.
 - c. Disconnect the gas line flare nut from the Gas Cushion Chamber (GCC) and the compression nut from the 3/16" copper pressure sensing line.
 - d. Disconnect the green ground lead from the Combustion Chamber and the ignition lead from the spark plug.
 - e. From the underside of the ACC, unscrew the 4-1/4" nuts. LIFT OFF THE ACC.
9. Remove the (4) four nuts securing the Gas Cushion Chamber (GCC) from the Combustion Chamber. Lift off the GCC and remove the flame trap from the Combustion Chamber - set them aside.
10. Remove the three nuts securing the bottom boiler flange to the Exhaust Cushion Chamber (ECC). Lift the Heat Exchanger off the ECC. (It may be necessary to pry the assemblies apart to break the seal).

BOILER REASSEMBLY [AM-100/-150]: Check that ECC is centered in the base pan and the 3 tabs in the base are pointed up to keep the ECC in position.

1. Remove seal from the ECC and clean the top surface of the chamber. Check the inside of the chamber and remove any loose particles.
2. Place a new seal on the ECC. To assure a leak tight seal, run a 1/4" wide bead of silicone on top of the seal.
3. Position the "new" Heat Exchanger by aligning the water supply and return connections with the condensate drain fitting and the 3 holes in the bottom flange with the studs in the ECC. Drop into place. Install the washers and nuts. Alternately and incrementally tighten the nuts to a maximum of 5 ft.-lb. (Overtightening can crack the ECC).
4. Run a 1/8" dia. bead of silicone on the top edge of the heat exchanger shell. Place the silicone "U" gasket over the shell. Apply silicone to each end of the gasket and butt the ends together. If the "U" gasket is too long, cut one end to maintain a butt fit. Position the gasket so that the bottom is a flat plane on top of the Heat Exchanger.
5. Place the flame trap in the Combustion Chamber, screw the (4) four studs into Combustion Chamber flange, position the GCC gasket over the studs.

6. Apply an anti-sieze compound to the threads of the spark plug and screw it into the Combustion Chamber.
7. Recheck the position of the "U" gasket on the Heat Exchanger. Position the Air Cushion Chamber on the Heat Exchanger with the wire harness opposite the supply and return water fitting. Align the studs on the bottom of the ACC with the brackets on the Heat Exchanger and carefully place in position. Check and straighten gasket, if necessary. Place a washer and nut on each stud. Securely attach the ACC to the Heat Exchanger by incrementally and alternately tightening each nut.
8. Install the GCC and clamp rings, placing the green ground lead under one nut securing the GCC. Align and tighten the gas supply tube to the GCC and connect the 3/16" pressure sensing tube. Connect the ignition lead to the spark plug.
9. Reattach the upper jacket panel.
10. Locate the lower jacket panel in the base pan, aligning:
 - a. The lower jacket with the base pan holes - screw together.
 - b. The boiler in line with the lower jacket holes and seams.
 Align all jacket holes and secure with screws.
11. Attach the high limit well, gas lines, gas valve and the air intake and exhaust adapter. Warning - **Do not** over-tighten plastic threaded adaptors. Install the high limit.
12. Mount the electric box and secure it to the jacket with the four screws.
 - a. Place bushing over end of wire harness.
 - b. Inside the electric box: exiting the wire harness connect.
 1. Copper pressure lines - bend the copper to mate with the union and plastic tubing.
 2. Red wire - connect to red wire on Molex from GC-4A by splicing together.
 3. Ignition wire - reattach to GC-4A spud.
 4. White wire - reattach to terminal 4 on terminal strip.
 5. Ground wire - attach to screw with green wire from GC-4.A
13. Reattach yellow and orange wires to gas valve and regulator vent pressure sensing line to regulator.
14. Reattach the brown and blue wire to the high limit.
15. Replace fan assembly (reconnect wires) spring and ACC lid. Position round insulation disc on ACC lid and replace jacket lid.
16. Reposition boiler and connect to system:
 - a. Water return and supply and condensate line.
 - b. Air inlet and exhaust.
 - c. Gas supply line.
 - d. Electrical power (115V) and thermostat connections.
17. Fill the boiler with water. Follow the Purging and Start-Up procedure in the Installation manual. Restore power and gas supplies - follow lighting/operating instructions on boiler.

GC-4A "QUICK CHECK" TROUBLESHOOTING GUIDE

MPTS-44

ELECTRICAL SYSTEM CHECK FOR BOILERS EQUIPPED WITH THE GC-4A IGNITION CONTROL

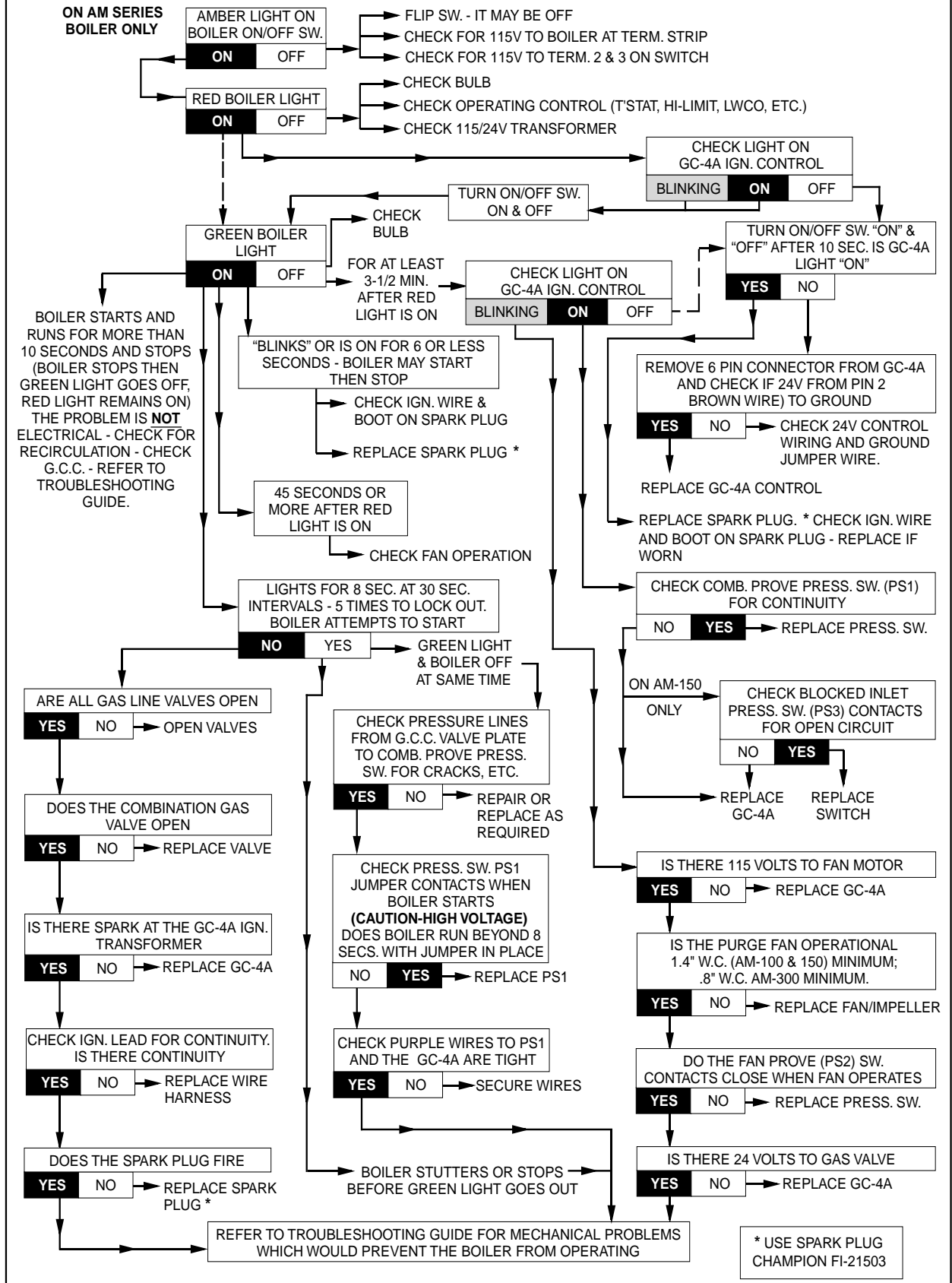

SECTION 4: REPLACEMENT PARTS LIST

ORDERING INFORMATION

When ordering replacement parts, provide the model and serial number shown on the unit rating plate as well as the part number and name as shown in parts list Parts may be obtained from your local Hydrotherm heating contractor

REF NO.	NAME OF PART	PART NO.	AM-100	AM-150	AM-300
1	Fiberglass Insulation Disc	70-1760	1		
	Fiberglass Insulation Disc	70-1774		1	
	Fiberglass Insulation Rectangle	45-1348			1
2	Air Chamber Cover Ass'y	BM-7026	1		
	Air Chamber Cover Ass'y	BM-7027		1	
	Air Chamber Cover Ass'y	BM-7156			1
3	Spring	60-3513	1	1	
4	Repl Blower Ass'y - NG	BM-7132		1	
	Repl Blower Ass'y - NG	BM-7153			1
	Repl Blower Ass'y - NG	BM-7131	1		
	Repl Blower Ass'y - LP	BM-7100	1		
	Repl Blower Ass'y - LP	BM-7248		1	
	Repl Blower Motor & Impeller Kit	BM-7179	1	1	
	Repl Blower Impeller Kit	BM-7249	1	1	
5	Repl Blower Motor	BM-7199			1
6	Air Cushion Chamber Ass'y	BM-7114	1		
	Air Cushion Chamber Ass'y	BM-7212		1	
	Air Cushion Chamber Ass'y	BM-7152			1
7	1-1/2" NPT(Male) to 1-1/2" Socket PVC Adapter	56-5033	1		
	2" NPT (Male) to 2" Socket PVC Adapter	56-3040		1	
	3" (Male) PVC Inlet Adapter w/Locknut	BM-7155			1
8	Gasket-Air Cushion Chamber	BM-7192			1
12	Gas Supply Tube - NG	BM-7112	1		
	Gas Supply Tube - NG	BM-7154			1
	Gas Supply Tube - LP	BM-7113	1		
	Gas Supply Tube - NG/LP	BM-7018		1	
13	Gas Inlet Pipe	70-1614	1		
	Gas Inlet Pipe	53-1208		1	
14	Nipple & Orifice Ass'y - NG (Color Code - Org.)	BM-7115	1		
	Nipple & Orifice Ass'y - NG (Color Code - Wht.)	BM-7215		1	
	Nipple & Orifice Ass'y - NG (Color Code - None)	BM-7159			1
	Nipple & Orifice Ass'y - LP (Color Code - Slv.)	BM-7580	1		
	Nipple & Orifice Ass'y - LP (Color Code - Red)	BM-7230		1	
15	Gas Valve 24v - NG	BM-7059	1	1	
	Gas Valve 24v - NG	BM-7061			1
	Gas Valve 24v - LP	BM-7060	1	1	

REF NO.	NAME OF PART	PART NO.	AM-100	AM-150	AM-300
—	Gas Cushion Chamber Kit - NG (Has Items 17, 18, 20)	BM-7236	1		
	Gas Cushion Chamber Kit - NG (Has Items 17, 18, 20)	BM-7238		1	
	Gas Cushion Chamber Kit - NG (Has Items 17, 18, 20)	BM-7240			1
	Gas Cushion Chamber Kit - LP (Has Items 17, 18, 20)	BM-7237	1		
	Gas Cushion Chamber Kit - LP (Has Items 17, 18, 20)	BM-7239		1	
17	Gas Cushion Chamber & Diaphragm Ass'y - NG (1)	BM-6003	1		
	Gas Cushion Chamber & Diaphragm Ass'y - NG (1)	BM-7013		1	
	Gas Cushion Chamber & Diaphragm Ass'y - NG (1)	BM-7151			1
	Gas Cushion Chamber & Diaphragm Ass'y - LP (1)	BM-6008	1		
	Gas Cushion Chamber & Diaphragm Ass'y - LP (1)	BM-7014		1	
18	Split Clamp Ring Set	BM-7020	1		
	Split Clamp Ring Set	BM-7021		1	
	Split Clamp Ring Set	BM-7194			1
19	Valve Diaphragm Pkg (11 pcs)	BM-7097	1	1	
	Valve Diaphragm Pkg (21 pcs)	BM-7197			1
20	Gasket - Gas Cushion Chamber	59-1025	1		
	Gasket - Gas Cushion Chamber	59-1031		1	
	Gasket - Gas Cushion Chamber	59-2012			1
21	Spark Plug (Champion FI-21503)	BM-7217	1	1	1
22	Flame Trap Ass'y - NG	BM-7087	1		
	Flame Trap Ass'y - NG/LP	BM-7010		1	
	Flame Trap Ass'y - LP	BM-7088	1		
23	Ignition Wire Ass'y	BM-7157			1
24	Repl Pressure Sensing Tube	BM-7158			1
28	Seal - UChannel	BM-7127	1		
	Seal - U Channel	BM-7214		1	
29	Heat Exchanger - 30psi	BM-7111	1		
	Heat Exchanger - 100psi	BM-7208		1	
	Heat Exchanger - 100psi	BM-7149			1
30	Seal - "O"Ring	59-2008	1		
	Seal - Gasket 3.8 ft.	59-1046		1	
	Seal - "O"Ring	59-2010			1
31	Exhaust Chamber Ass'y	BM-7110	1		
	Exhaust Chamber Ass'y	BM-7270		1	
32	1-1/2" NPT(Male) to 1-1/2" Socket CPVC Adapter	56-5034	1		
	2" NPT (Male) to 2" Socket CPVC Adapter	56-3041		1	
	3" (Male) CPVC Inlet Adapter	BM-7165			1
33	3" CPVC Locknut	BM-7202			1
34	Condensate Drain Fitting	56-5709	1	1	
	Condensate Drain Fitting	56-5713			1
35	Wire Harness	40-5033	1		
	Wire Harness	40-5034		1	
36	Gasket - Heat Exchanger to Economizer	BM-7193			1
37	Combustion Chamber Inlet (Includes Item 30)	BM-7150			1
38	Economizer - 100psi	BM-7147			1
39	900 Elbow Coupling - 1-1/2" (w/Gaskets)	56-5908			1
40	Gasket Kit (For Item 39)	BM-7198			2
41	Flue Box Ass'y (w/Items 32, 33 & 42) - Old 8 Hole Style	BM-7164			1
	Flue Box Ass'y (w/o Item 32)	BM-7200			1
	Flue Box Ass'y (w/Items 32, 33 & 42) - New 8 Hole Style	BM-7266			

(1) Item 20 must also be ordered with Item 17.

REF NO.	NAME OF PART	PART NO.	AM-100	AM-150	AM-300
42	Flue Box Gasket Only - Old 3 Hole Style Flue Box Gasket Only - New 3 Hole Style	BM-7201 59-1046			1
46	Repl Control Box - NG/LP Repl Control Box - NG/LP	BM-7128 BM-7210	1	1	
47	Combustion Prove Pressure Switch	02-4851	1	1	1
48	Bracket Ass'y - Pressure Switch	03-4367	1	1	
49	Tube - Pressure Switch Tube - Pressure Switch	BM-7122 BM-7055	1	1	
50	Fan Prove Switch Fan Prove Switch	BM-7057 BM-7058	1	1	1
51	Blocked Inlet Pressure Switch	02-4871	1		
52	Terminal Strip, 5 Pole	BM-7070	1	1	
53	Terminal Strip, 2 Pole, Thermostat	58-2313	1	1	1
54	Gas Valve/Fan Prove Harness Gas Valve Harness Gas Valve Harness	40-5162 42-5160 40-5164	1	1	1
55	Fan Control Wire Harness Fan Control Wire Harness Fan Control Wire Harness	40-5163 40-5161 40-5264	1	1	1
57	Transformer - 115/24v Transformer - 115/24v Transformer - 115/24v	BM-7105 BM-7106 BM-7161	1	1	1
58	Solid State Ignition Control - GC-4A	BM-7256	1	1	1
59	Electric Sub Panel	BM-7162			1
60	Junction Box w/Terminal Strip 4 x 4	BM-7163			1
61	Indicator Lamp - Red	BM-7232	1	1	1
62	Indicator Lamp - Green	BM-7233	1	1	1
—	Silicone Sealant - 11 oz.	10-6631	1	1	1
—	Urethane Tape (4 ft. long)	BM-7137	1	1	
63	Lighted ON/OFF Rocker Switch	58-1538	1	1	1
FOLLOWING COMMON "STREET" PARTS MAY BE AVAILABLE FROM YOUR LOCAL WHOLESALER					
64	Pressure Relief Valve - 30psi Pressure Relief Valve - 50psi Pressure Relief Valve - 75psi Pressure Relief Valve - 100psi	22-1203 22-1007 22-1803 22-1201	1	1 1 1 1	1 1 1 1
65	Temp/Press Indicator - 30 & 50psi Temp/Press Indicator - 30 & 50psi Temp/Press Indicator - 75 & 100psi	20-1015 20-1003 20-1011	1	1 1 1	1 1 1
66	Bushing - 1" x 1/4" Bushing - 1-1/4" x 1/4" Bushing - 1-1/4" x 1/2" (75 & 100psi T/P Indicator) Bushing - 1-1/2" x 1/4" Bushing - 1-1/2" x 1/2" (75 & 100psi T/P Indicator)	56-4007 56-4227 56-4228 56-4229 56-4204	1	1 1 1	1 1
67	Bushing - 1" x 3/4" Bushing - 1-1/4" x 3/4" Bushing - 1-1/2" x 3/4"	56-4003 56-4226 56-4205	2	1 1	2
68	Nipple - 1" x 3" T.O.E. Nipple - 1-1/4" x 4" T.O.E. Nipple - 1-1/2" x 3-1/2" T.O.E.	53-1202 53-1260 53-1326	2	2	1
69	Hose Hose	54-3301 54-3302	2	2	

REF NO.	NAME OF PART	PART NO.	AM-100	AM-150	AM-300
FOLLOWING COMMON "STREET" PARTS MAY BE AVAILABLE FROM YOUR LOCAL WHOLESALER					
70	Hose Clamp Hose Clamp	57-4907 57-4906	4	4	
71	Cross - 1" Cross - 1-1/4" Cross - 1-1/2"	56-5101 56-5103 56-5104	1	1	1
72	Nipple - 1" x 16" LG	53-1206	1		
	Nipple - 1-1/4" x 18-1/2" LG Nipple - 1-1/2" x 18" LG	53-1262 53-1327		1	1
73	Nipple - 1" x 3" LG Nipple - 1-1/4" x 3" LG	53-1207 53-1250	1	1	
74	Elbow - 1" Elbow - 1-1/4"	56-3305 56-3306	1	1	
75	Stud - 5/16-18 x 1-1/4" LG	44-1052	4	4	4
76	Well - 1/2" Well - 1/2"	02-3413 02-3408	1	1	1
77	Single Hi-Limit w/o Well Single Hi-Limit w/o Well	BM-7086 02-3207	1	1	1
78	Pipe Plug - 1" Sq. Head	56-4550			1
79	Drain Valve	51-1204	1	1	1
80	Cap Screw - St. Stl., 1/4 x 20 x 1" LG	57-2907			4
81	900 Elbow - 1/2" FPT to 1/2" Comp, NG/LP 900 Elbow - 1/2" FPT to 5/8" Comp, NG 900 Elbow - 1/2" FPT x 1/2" FPT	56-5515 56-5516 56-3303	1 1	1	
82	Connector - Flare, 1/2 NPT x 5/8	56-5488		1	
83	Union - 3/16 Comp Union - 3/4"	56-5500 56-4801	1	2	1 1
84	Elbow - 3/4" Elbow - 1/2"	56-3304 56-3303	1	1	2
85	Pipe Plug - 1/8" Sq. Hd.	56-4600	1	1	1
86	Bushing - 1/8" Comp	56-5499	1	1	1
87	Nipple - 3/4" x Close	53-1120			1
88	Tee - 1/4"	56-1000			1
89	Pipe Plug - 1/4" Sq. Hd.	56-4605			1
90	Connector - Comp, 3/4" x 5/8"	56-5518			1
91	Connector - Barb, 1/8 NPT x 3/16	56-5711			2
92	Connector - 1/8 NPT x 3/16 Comp	56-5494			1
93	Bushing - 1/4" x 1/8"	56-4012			1
94	Tee - 3/16 ID Barb	56-5710	1	1	1
95	Vinyl Tubing Harness - 3/16" (9" long)	54-3212	1	1	1
96	Copper Tubing - 1/8" (20" long)	54-2060	1	1	
97	Connector - Elbow, 1/4 NPT x 3/16 Comp	56-5489	1	1	
98	Tee - 3/16 Comp	56-5492	1		
99	Circulator Relay	26-3519	1	1	

JACKET PARTS AND ACCESSORY KITS (Quantity: 1 each)

REF NO.	NAME OF PART	PART NO.		
		AM-100	AM-150	AM-300
104	Jacket Top Cover	BM-7039	BM-7040	
105	Jacket Upper Panel	BM-7260	BM-7263	
106	Jacket Lower Panel	BM-7261	BM-7264	
107	Jacket Bottom Cover	BM-7144	BM-7048	
108	Jacket Access Panel	BM-7262	BM-7265	
109	Jacket Lower Front Panel			BM-7166
110	Jacket Upper Front Panel			BM-7167
111	Jacket Access Front Panel			BM-7168
112	Jacket Lower Rear Panel			BM-7171
113	Jacket Upper Rear Panel			BM-7170
114	Jacket Top Access Panel			BM-7169
115	Jacket Side Panel - Right			BM-7173
116	Jacket Side Panel - Left			BM-7172
—	Touch-Up Spray Paint Kit	60-2852	60-2852	60-2852
—	Repl Piping Tree Kit - 30psi (2)		BM-7224	
—	Repl Piping Tree Kit - 100psi (2)		BM-7225	
—	Repl Piping Tree Kit (3)			BM-7226
—	5 Yr Tune-Up Kit - NG (4)	BM-8197	BM-8198	BM-8199
—	5 Yr Tune-Up Kit - LP (4)	BM-8197	BM-8198	
—	5 Yr Tune-Up Kit - NG (Incl. Replacement Regul.) (5)	BM-7243	BM-7245	BM-7247
—	5 Yr Tune-Up Kit (Incl. Replacement Regul.) (5)	BM-7244	BM-7246	

(2) Includes Items 64 thru 74.

(3) Includes Items 71 & 72 only.

(4) Includes Items 19, 20 & 21.

(5) Includes Items 19, 20 & 21 and Replacement Regulator for VR8450M Gas Valve.

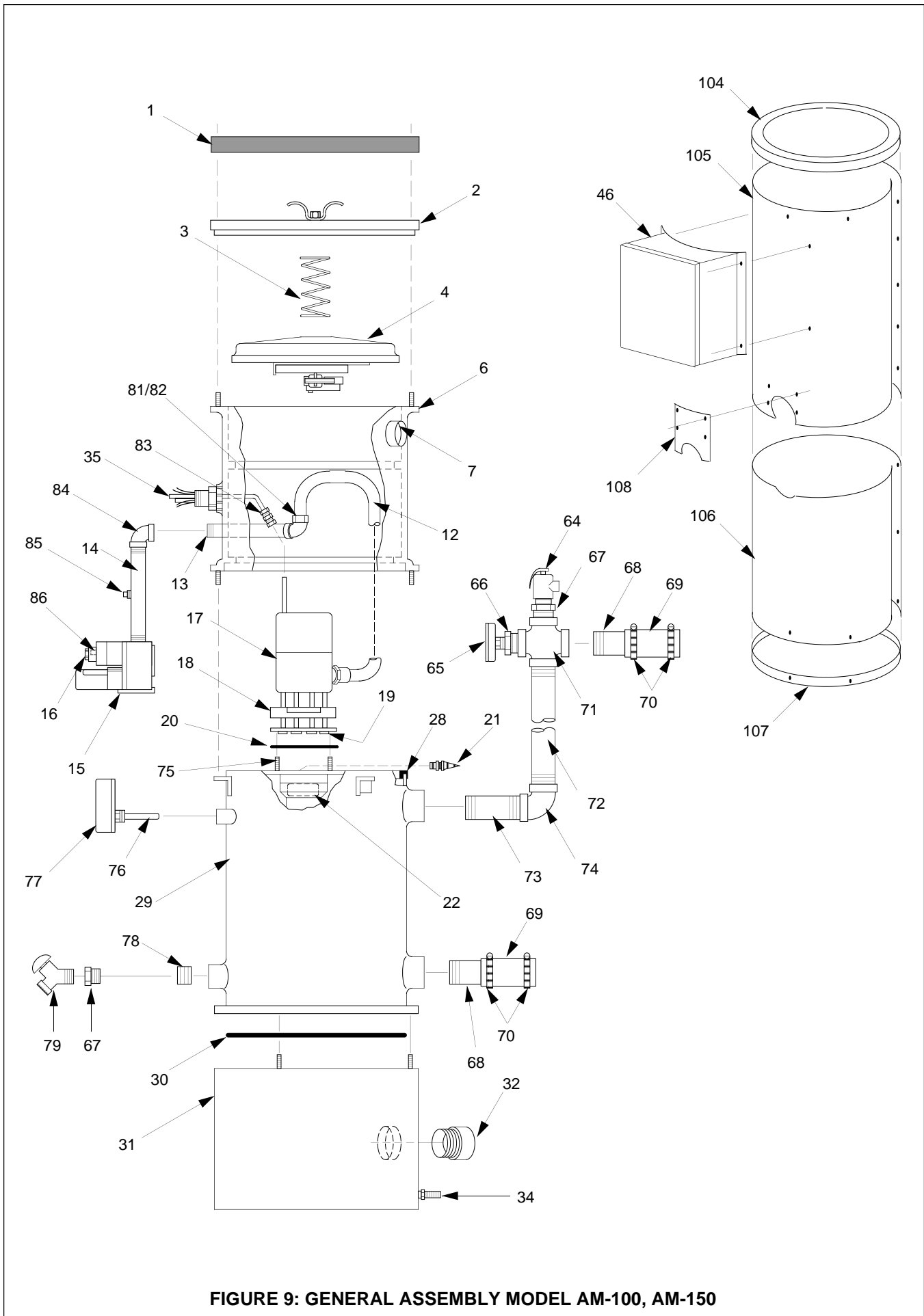

FIGURE 9: GENERAL ASSEMBLY MODEL AM-100, AM-150

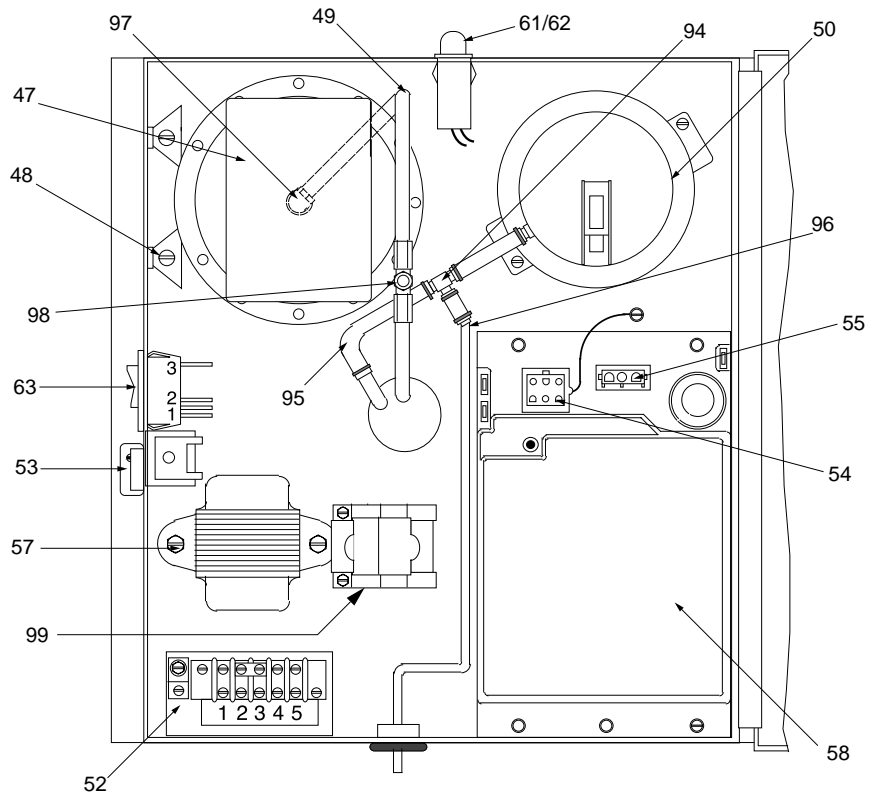

FIGURE 10: MODEL AM-100 CONTROL PANEL

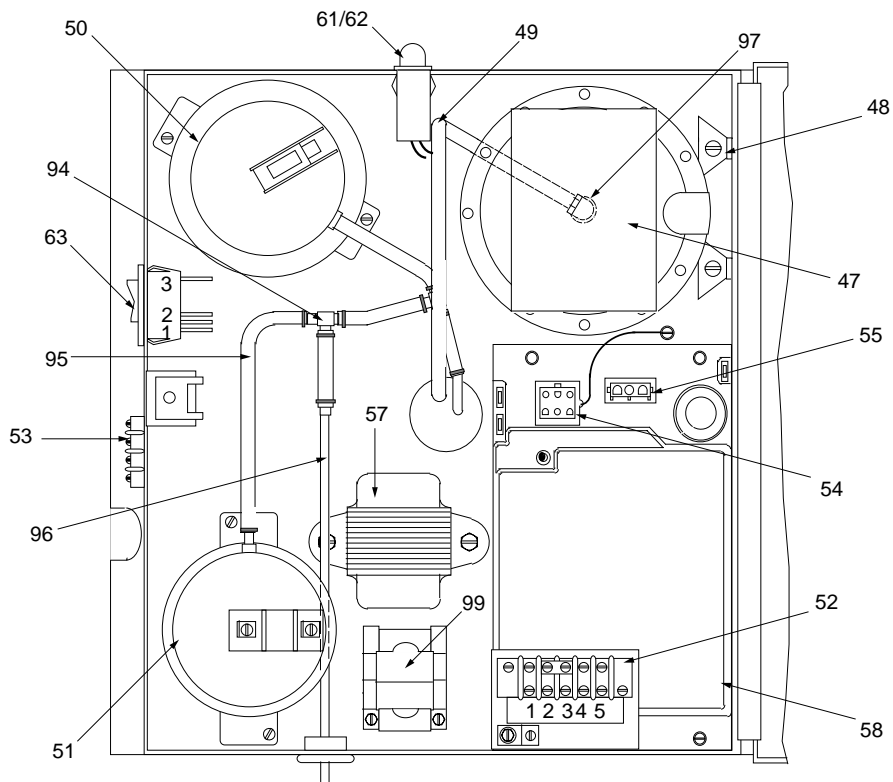
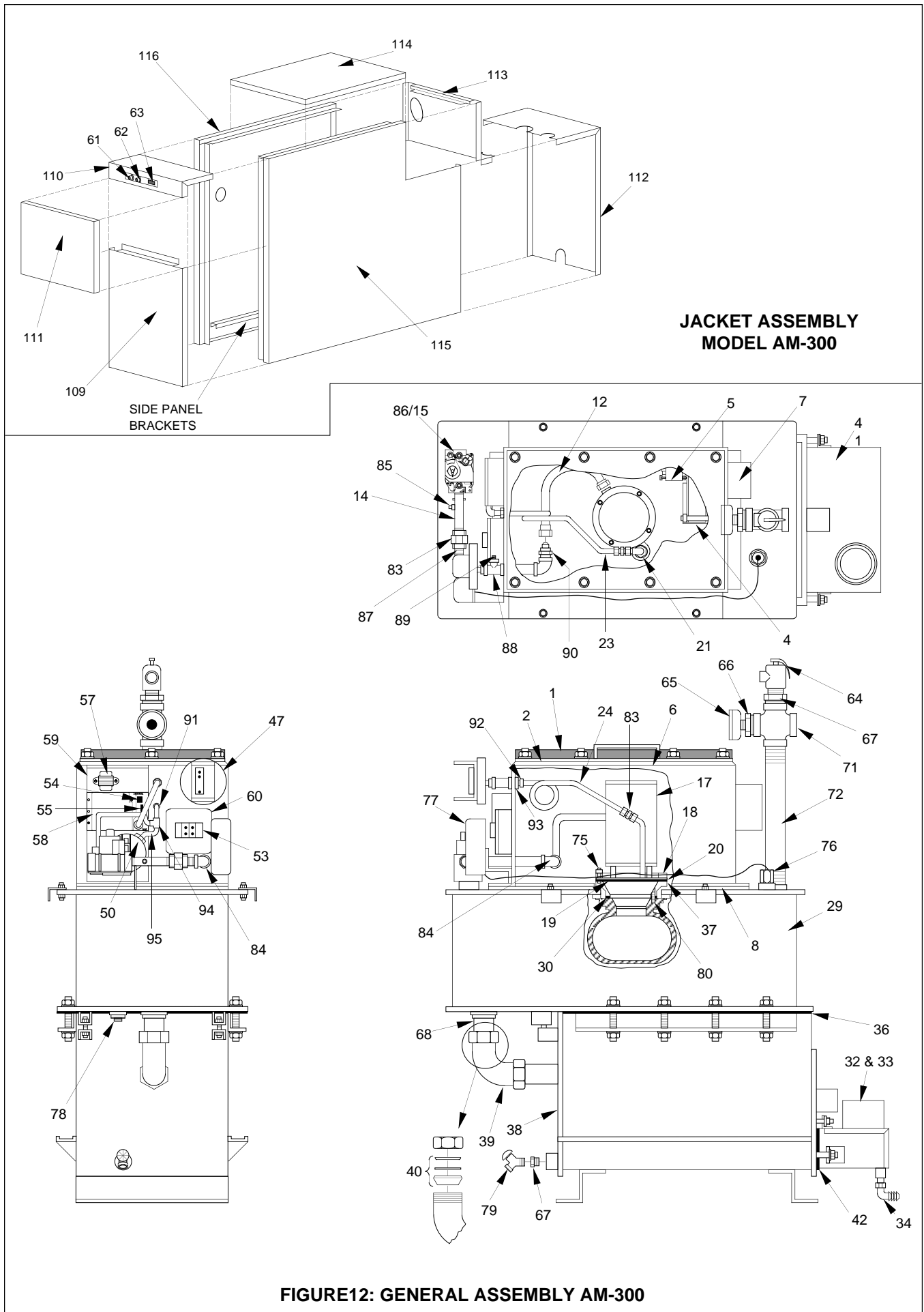

FIGURE 11: MODEL AM-150 CONTROL PANEL



260 NORTH ELM STREET
WESTFIELD, MA 01085
(413) 568-9571 • FAX (413) 568-9613

HydroTherm[®]

5211 CREEKBANK ROAD
MISSISSAUGA, ONTARIO L4W 1R3 CANADA
(905) 625-2991 • FAX (905) 625-6610