

Installation and User Guide

ZonePRO Thermostats

1. Introduction

The TB6980/TB7980 digital thermostats provide proportional plus integral individual space temperature control in zoned commercial HVAC systems such as hydronic and pressure dependent VAV with or without reheat. There are four different models:

- TB7980A (single output, modulating) • TB6980A (single output, floating)
- TB7980B (multiple output modulating) • TB6980B (multiple output, floating)

Depending on the models, the thermostat can have up to three outputs for the following applications:

- ▶ Floating or Modulating damper/valve actuator control
- ▶ Damper/valve actuator control with duct reheat and auxiliary heat (B models only)
- ▶ Hydronic systems (room control, perimeter heating and cooling)

Accessories

- ▶ R841 family of electromechanical relays
- ▶ T7770A3002 remote room sensor
- ▶ 50014156-002 remote room sensor
- ▶ 32004800-001 bare thermistor
- ▶ 50014157-001 duct temperature sensor

2. Installation

2.1 Mounting Instructions

1. Remove the thermostat from its base by unscrewing the captive screw and tilting the bottom of the thermostat up. The screw cannot be completely removed.

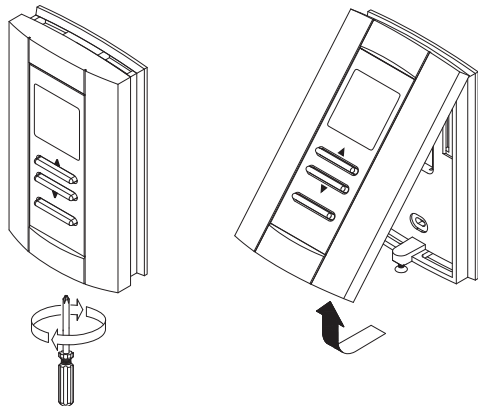

2. Pass the wires through the center hole of the base and secure the base to the wall or onto an electrical box.
3. Wire the thermostat. See section 2.2 for terminal designations and section 3 for typical wiring diagrams.
4. Reinstall the thermostat onto its base and secure with the captive screw.

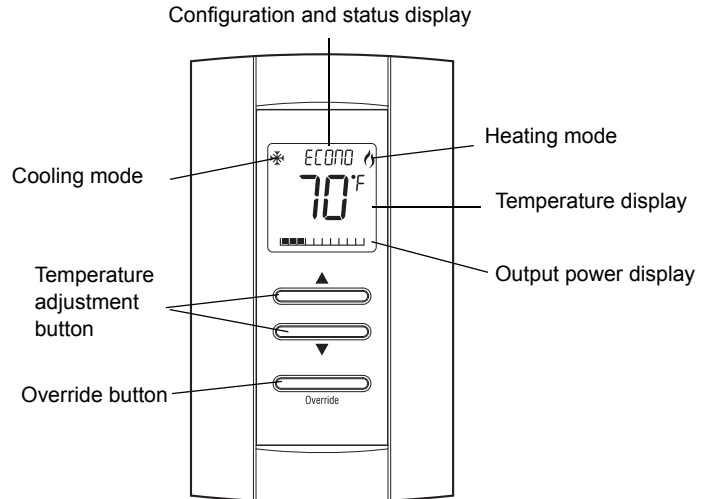

2.2 Terminal Designations

The designations of the terminals vary according to the particular model of thermostat. Refer to the following table for the description of each terminal.

TERMINAL	DESCRIPTION
1 2	24 VAC COM Power supply
3 4	AN1 COM Output 1 TB7980 models
3 4	OPEN CLOSED Output 1 TB6980 models
5 6	T2/AN2 T2/COM Output 2 (TB6980B and TB7980B models)
7 8	T3 T3 Output 3 (TB6980B and TB7980B models)
9 10	COM SENSOR External sensor input. (For applications requiring an external sensor, see section 4.2.)
9 11	COM C-Over Mode Changeover input (N.O. contact). See section 5.5.2.
9 12	COM NSB Night Setback activation input (N.O. contact). See section 5.6.

Note: To configure the terminals, see section 4.



3. Typical Applications

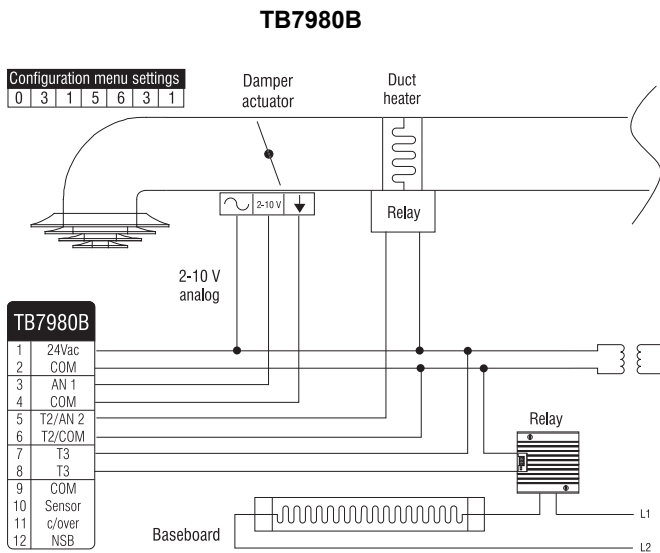

FIGURE 1: Damper control with electric reheat and auxiliary baseboard heating.

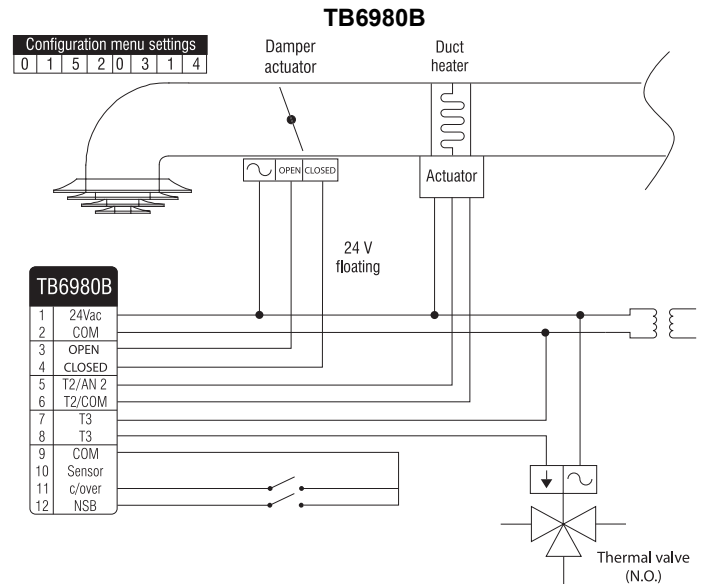

FIGURE 2: Damper control with electric reheat and auxiliary hot-water heating

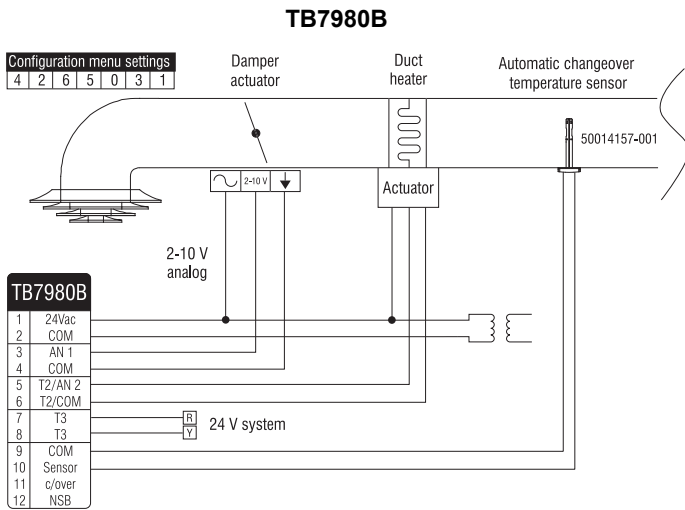

FIGURE 3: Damper control with automatic changeover, electric reheat and central cooling

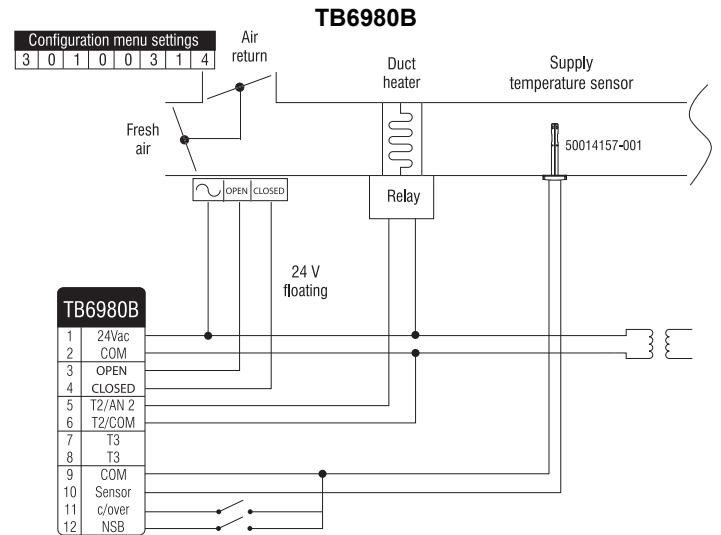

FIGURE 4: Temperature control of fresh air supply

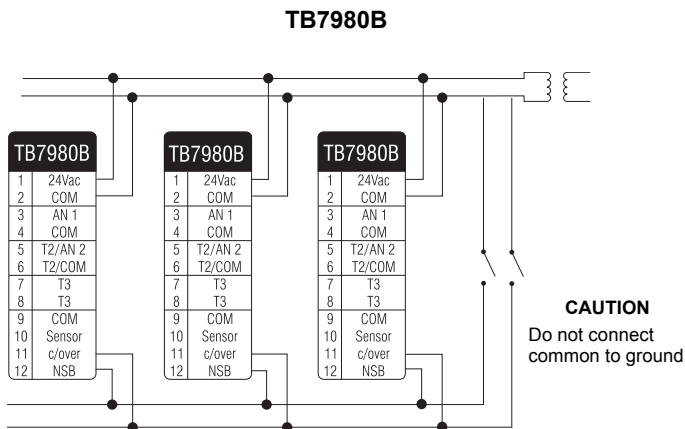

FIGURE 5: Changeover and NSB inputs sharing the same 24-Vac transformer

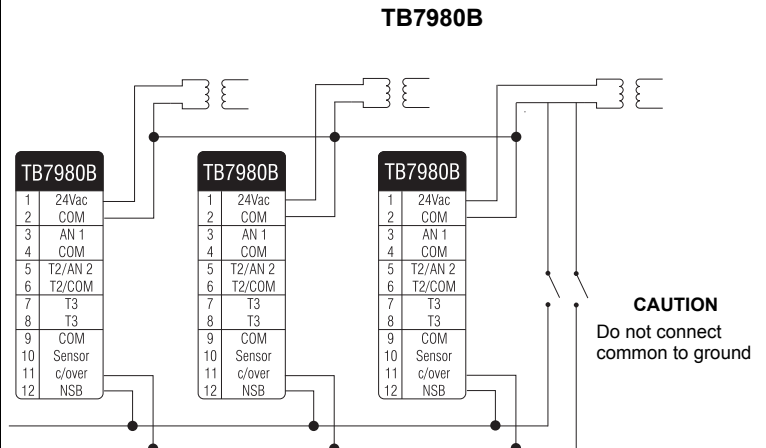

FIGURE 6: Changeover and NSB inputs using different 24-Vac transformers

4. Configuration

4.1 Configuration Menus (See following pages for explanations)

NOTE: Factory settings are inside the shaded cells.

TB7980A model					
Application (section 4.2)	Default mode & Output 1 type (section 4.3.1)	NSB value (section 5.6)	Output 1 min. opening (section 4.3.2)	Maximum setpoint (section 4.6)	Minimum setpoint (section 4.6)
0 Internal sensor	0 Cool / 0-10V	1 2°F (1°C)	0 0%	Can be set between 95°F (35°C) and "minimum setpoint + 1" Default value is 95°F (35°C)	Can be set between 50°F (10°C) and "maximum setpoint - 1" Default value is 50°F (10°C)
1 Room	1 Heat / 0-10 V	2 4°F (2°C)	1 10%		
2 Return	2 Cool / 2-10 V	3 6°F (3°C)	2 20%		
3 Supply	3 Heat / 2-10 V	4 8°F (4°C)	3 30%		
4 Auto changeover		5 10°F (5°C)	4 40%		
5 Limited cooling		6 12°F (6°C)	5 50%		
		7 14°F (7°C)			
		8 16°F (8°C)			
		9 18°F (9°C)			

1. Remove the thermostat from its base and set the SW2 switch to **MENU**.
2. Reinstall the thermostat. The thermostat is now in configuration mode. The first digit flashes to indicate that the first item of the menu can now be modified.
3. To modify the setting, use the up/down arrows. Refer to the adjacent tables.
4. Press **Override** to save the new setting and go to the next item.
5. Repeat steps 3 and 4 for remaining items.
6. When the configuration is done, set the SW2 switch back to **NORMAL**.

TB6980A model						
Application (section 4.2)	Default mode (section 4.3.1)	NSB value (section 5.6)	Output 1 min. opening (section 4.3.2)	Output 1 opening time (section 4.3.3)	Maximum setpoint (section 4.6)	Minimum setpoint (section 4.6)
0 Internal sensor	0 Cool	1 2°F (1°C)	0 0%	0 80	Can be set between 95°F (35°C) and "minimum setpoint + 1" Default value is 95°F (35°C)	Can be set between 50°F (10°C) and "maximum setpoint - 1" Default value is 50°F (10°C)
1 Room	1 Heat	2 4°F (2°C)	1 10%	1 90		
2 Return		3 6°F (3°C)	2 20%	2 100		
3 Supply		4 8°F (4°C)	3 30%	3 110		
4 Auto changeover		5 10°F (5°C)	4 40%	4 120		
5 Limited cooling		6 12°F (6°C)	5 50%	5 130		
		7 14°F (7°C)		6 140		
		8 16°F (8°C)		7 150		
		9 18°F (9°C)		8 160		

ABBREVIATIONS
NSB - Night setback (number of degrees the thermostat will be set back upon receiving a setback signal)
SSR - Solid state relay (used with fast cycling electric heaters, SSR's are a quiet alternative to electromechanical relays. They're typically included with electric duct reheat equipment)
SCR - Silicon controlled rectifier (similar to an SSR, SCR's are also quiet and capable of switching very high current. If used, they're usually included with the equipment)
N.C. - Normally closed
N.O. - Normally open

TB7980B model								
Application (section 4.2)	Default mode & Output 1 type (section 4.3.1)	Output 2 type ^a (section 4.4)	Output 3 type (section 4.5)	Output 3 activation (section 4.5)	NSB value (section 5.6)	Output 1 min. opening (section 4.3.2)	Maximum setpoint (section 4.6)	Minimum setpoint (section 4.6)
0 Internal sensor	0 Cool / 0-10V	0 Not used	0 Not used	0 100%	1 2°F (1°C)	0 0%	Can be set between 95°F (35°C) and "minimum setpoint + 1" Default value is 95°F (35°C)	Can be set between 50°F (10°C) and "maximum setpoint - 1" Default value is 50°F (10°C)
1 Room	1 Heat / 0-10 V	1 SSR 24 VAC	1 SSR 24 VAC	1 10%	2 4°F (2°C)	1 10%		
2 Return	2 Cool / 2-10 V	2 N.C. Valve	2 N.C. Valve	2 20%	3 6°F (3°C)	2 20%		
3 Supply	3 Heat / 2-10 V	3 N.O. Valve	3 N.O. Valve	3 30%	4 8°F (4°C)	3 30%		
4 Auto changeover		4 Mech. relay	4 Mech. relay	4 40%	5 10°F (5°C)	4 40%		
5 Limited cooling		5 SSR 3-32 V	5 Contact	5 50%	6 12°F (6°C)	5 50%		
		6 SCR 0-10 V		6 60%	7 14°F (7°C)			
		7 Act. 0-10 V		7 70%	8 16°F (8°C)			
		8 Act. / 2-10 V		8 80%	9 18°F (9°C)			

a. If Output 2 type is set to 0-4, set the SW6 switch to Triac. If the output type is set to 5-8, set the switch to Analog (see section 4.7).

TB6980B model									
Application (section 4.2)	Default mode (section 4.3.1)	Output 2 type ^a (section 4.4)	Output 3 type (section 4.5)	Output 3 activation (section 4.5)	NSB value (section 5.6)	Output 1 min. opening (section 4.3.2)	Output 1 opening time (section 4.3.3)	Maximum setpoint (section 4.6)	Minimum setpoint (section 4.6)
0 Internal sensor	0 Cool	0 Not used	0 Not used	0 100%	1 2°F (1°C)	0 0%	0 80	Can be set between 95°F (35°C) and "minimum setpoint + 1" Default value is 95°F (35°C)	Can be set between 50°F (10°C) and "maximum setpoint - 1" Default value is 50°F (10°C)
1 Room	1 Heat	1 SSR 24 VAC	1 SSR 24 VAC	1 10%	2 4°F (2°C)	1 10%	1 90		
2 Return		2 N.C. Valve	2 N.C. Valve	2 20%	3 6°F (3°C)	2 20%	2 100		
3 Supply		3 N.O. Valve	3 N.O. Valve	3 30%	4 8°F (4°C)	3 30%	3 110		
4 Auto changeover		4 Mech. relay	4 Mech. relay	4 40%	5 10°F (5°C)	4 40%	4 120		
5 Limited cooling		5 SSR 3-32 V	5 Contact	5 50%	6 12°F (6°C)	5 50%	5 130		
		6 SCR 0-10 V		6 60%	7 14°F (7°C)		6 140		
		7 Act. 0-10 V		7 70%	8 16°F (8°C)		7 150		
		8 Act. / 2-10 V		8 80%	9 18°F (9°C)		8 160		

a. If Output 2 type is set to 0-4, set the SW6 switch to Triac. If the output type is set to 5-8, set the switch to Analog (see section 4.7).

4.2 Application Types

The following table shows the different thermostat applications and their corresponding settings in the configuration menu.

Menu setting		Description
0	Internal sensor	To control the ambient temperature using the internal (built-in) sensor
1	Room	To control the ambient temperature using the 50014156-002 temperature sensor (the internal sensor is not used)
2	Air return	To control the temperature at the air return using the 50014157-001 temperature sensor (the internal sensor is not used)
3	Air supply	To control the temperature at the fresh air supply using the 50014157-001 temperature sensor (the internal sensor is not used)
4	Automatic changeover	To control the ambient temperature using the internal sensor. The 50014157-001 temperature sensor is used for automatic changeover. See section 5.5.1.
5	Limited cooling	To use the outdoor air for cooling whenever possible. The 50014157-001 temperature sensor is used to measure the outdoor air temperature. The internal temperature sensor measures the room temperature which is then compared with the setpoint. If the room temperature is lower than the setpoint, the air intake damper remains closed. If the room temperature is higher than the setpoint, the latter is then compared with the outdoor temperature. If the fresh air temperature is lower than the setpoint by more than 5°F(3°C), the damper opens to allow cool air in.

4.3 Output 1

Output 1 is used to control a damper. It controls heating when the thermostat is in heat mode or cooling when the thermostat is in cool mode.

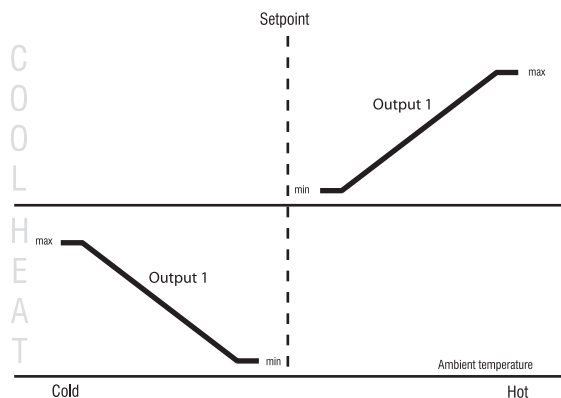

Set the following configuration parameters:

- Default mode
- Output type (TB7980 models only)
- Minimum opening
- Opening time (TB6980 models only)

4.3.1 Default Mode / Output Type

The default mode (heat/cool) is used for the following:

- The default mode is the thermostat's mode at power-up.
- The default mode is the active mode when the N.O. changeover contact is open (see section 5.5.2).
- When configured as a contact (see section 4.5), Output 3 controls either heating or cooling depending on whether the default mode is set to heat or cool respectively.

The following table shows the different default modes, the different output types for Output 1, and their corresponding settings in the configuration menu.

Menu setting	TB7980 models	TB6980 models
0	Cool / 0-10 V analog (max. of 10 min. refresh)	Cool (24 V tri-state floating)
1	Heat / 0-10 V analog (max. of 10 min. refresh)	Heat (24 V tri-state floating)
2	Cool / 2-10 V analog (max. of 10 min. refresh)	
3	Heat / 2-10 V analog (max. of 10 min. refresh)	

4.3.2 Minimum Opening

The minimum damper opening can be set between 0 and 50 %.

Note: It is not recommended to set the minimum damper opening to 0 % (fully closed) when a duct heater is connected to Output 2 or 3.

4.3.3 Opening time (TB6980 models only)

The damper opening time can be set between 80 and 160 seconds.

4.4 Output 2 (models TB6980B and TB7980B)

Output 2 controls heating only, regardless of the thermostat's mode. When the thermostat is in heat mode, Output 2 is activated as soon as Output 1 reaches its full capacity. When the thermostat is in cool mode, Output 2 is activated when the measured temperature drops below the setpoint.

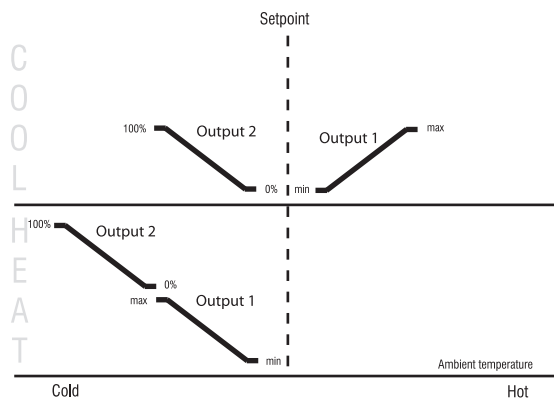

The following table shows the output types for Output 2 and their corresponding settings in the configuration menu.

Menu setting	Description
0	Not used
1	24 VAC pulsed (triac) / 1 sec. cycle
2	24 VAC pulsed (triac) / 10 min. cycle / direct action (e.g., N.C. thermal valve)
3	24 VAC pulsed (triac) / 10 min. cycle / reverse action (e.g., N.O. thermal valve)
4	24 VAC pulsed (triac) / 15 min. cycle (e.g., mechanical relay such as R841)
5	0-10 V pulsed / 1 sec. cycle
6	0-10 V analog / 1 sec. refresh (e.g., SCR controlled device such as a re-heater)
7	0-10 V analog / max. of 10 min. refresh (e.g., valve)
8	2-10 V analog / max. of 10 min. refresh (e.g., damper)

Note: If 0-4 is selected, set the SW6 switch to Triac. If 5-8 is selected, set the switch to Analog (see section 4.7)

4.5 Output 3 (models TB6980B and TB7980B)

The following table shows the output types for Output 3 and their corresponding settings in the configuration menu.

Menu setting	Description
0	Not used
1	24 VAC pulsed (triac) / 1 sec. cycle
2	24 VAC pulsed (triac) / 10 min. cycle / direct action (e.g., N.C. thermal valve)
3	24 VAC pulsed (triac) / 10 min. cycle / reverse action (e.g., N.O. thermal valve)
4	24 VAC pulsed (triac) / 15 min. cycle (e.g., mechanical relay such as R841)
5	N.O. contact (The contact closes when Output 1 reaches or exceeds set percentage. See section 4.1.)

When any setting between 1 and 4 is selected, Output 3 controls heating only, regardless of the thermostat's mode.

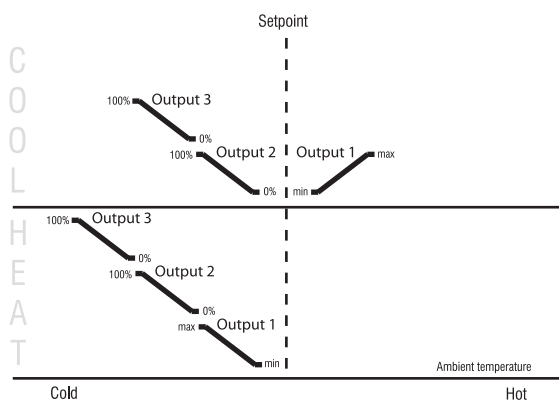

When setting 5 is selected, Output 3 controls heating or cooling depending on whether the default mode has been set to heat or cool respectively (see section 4.3.1). For example, if the default mode has been set to heat mode, the contact remains opened when the thermostat is in cool mode. When the thermostat is in heat mode, the contact closes when Output 1 reaches a percentage of its capacity, set via the configuration menu.

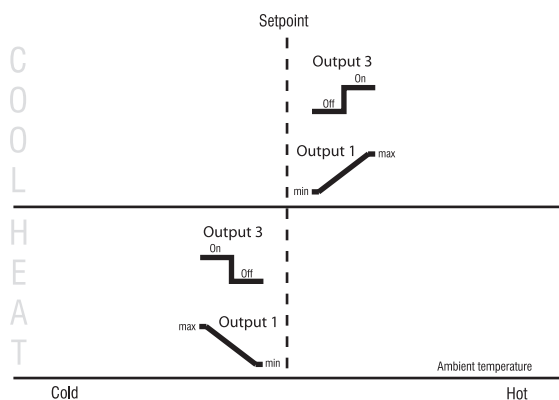

4.6 Minimum and Maximum Setpoints

The minimum and maximum setpoints are factory-set at 50°F (10°C) and 95°F (35°C). The maximum setpoint can be set between 95°F (35°C) and "minimum setpoint + 1". The minimum setpoint can be set between 50°F (10°C) and "maximum setpoint - 1".

4.7 DIP Switches

Three switches at the back of the control module are used to select various options.

Temperature Display (SW1)

Selects the desired temperature display (°C or °F).

Access Mode (SW2)

Selects the operation mode (NORM) or the configuration mode (MENU).

- Place the switch to MENU to access the configuration menu.
- Place the switch to NORM for normal display.

Output 2 Type (SW6)

Sets Output 2 type (Analog or Triac).

WARNING: Place the switch according to the type of device (Analog or Triac) connected to Output 2. Failure to do so can result in thermostat damage.

5. Operation

5.1 Power-Up

Upon power-up, the thermostat undergoes a series of test before displaying the actual temperature.

Note: On the TB6980A and TB6980B models, at power-up, the message OPEN appears at the top of the screen during the calibration of the damper opening. This can last up to 3 minutes.

5.2 Backlight

To turn the backlight on, press any button. The display will illuminate for 12 seconds.

5.3 Temperature Display and Setting

The thermostat usually displays the actual temperature. To view the setpoint, press once on one of the ▲▼ buttons. The setpoint appears for 5 seconds and is indicated by the ► display. During the setpoint display, press one of the ▲▼ buttons to change it.

Note: The temperature setpoint is automatically increased or decreased by 2°F (1°C) when the controller switches to heating mode or to cooling mode respectively. For example, if the setpoint is at 77°F (25°C) in heating mode, it will become 79°F (26°C) in cooling mode and will return to 77°F (25°C) when the controller is back in heating mode.

5.4 Output Display

The bar graph represents the voltage for an analog output or the duty cycle for a triac output. The bar graph usually shows Output 1 power (% of damper opening).

To view Output 2 or 3, press Override for 2 seconds to enter the diagnostic mode. Press Override momentarily to switch between the three output graphs. To exit the diagnostic mode, press Override for 2 seconds or wait for 1 minute for the mode to exit automatically.



5.5 Mode Changeover

The thermostat can switch between heat mode and cool mode either via:

- the automatic changeover
- the changeover input

5.5.1 Automatic changeover

In automatic changeover, the thermostat detects when the system switches between heat mode and cool mode by comparing the air supply temperature with the ambient temperature. If the thermostat is in heat mode, it switches to cool mode when the air supply is cooler than ambient by 9°F (5°C) or more. If it is in cool mode, it switches to heat mode when the air supply is warmer than ambient by 9°F (5°C) or more.

Note: Neither the heat mode icon (♠) nor cool mode icon (♣) appears when the thermostat is placed in automatic changeover.

5.5.2 Changeover Input

The thermostat is in the default mode when the contact between terminals 9 and 11 is open and switches mode when the contact is closed. The default mode is set via the configuration menu.

Note: The changeover contact state is ignored if the thermostat is configured in automatic changeover or in limited cooling.

5.6 Night Setback

The Night Setback (NSB) mode is activated when the contact between terminals 9 and 12 is closed. When the thermostat is in the NSB mode, indicated by the ECONO display, the temperature is lowered or raised by the set NSB value depending whether the thermostat is in heat mode or cool mode respectively. The NSB value is set via the configuration menu.



Night Setback Override

To temporarily override the NSB mode, press the Override button. The NSB mode is lifted for the next 2 hours or until the Override button is pressed again. During the override, the normal setpoint is used and OVERRIDE is displayed.



5.7 Error Codes

The following error codes can appear at the top of the display.

- E1: The internal temperature sensor is defective
- E2: The internal temperature sensor is shorted
- E3: The external temperature sensor is defective or not connected
- E4: The external temperature sensor is shorted

6. Technical Specifications

Power: 24 VAC

Current consumption: 25 mA

Output signals: Depends on output configurations

Output ratings:

- Triac output: 0.5 A maximum @ 24 VAC
- Analog output (SCR connection): 0 - 10 V, 10kΩ minimum
- Analog output (SSR connection): 0 - 10 V, 45 mA maximum

Setpoint range: 50°F to 95°F (10°C to 35°C)

Temperature display: 32°F to 140°F (0°C to 60°C)

Temperature display resolution: 1°F (0.5°C)

Mode hysteresis: 4°F (2°C)

Automatic changeover deadband: 9°F (5°C)

Duty cycle: Depends on output configurations

NSB offset: Programmable 2°F to 18°F (1°C to 9°C)

NSB override period: 2 hours

Memory protection: Configuration and setpoint

Temperature control: Proportional integral adaptive (P.I.A.)

Operating temperature: 32°F to 140°F (0°C to 60°C)

Storage temperature: -4°F to 122°F (-20°C to 50°C)

Humidity limits: 0 to 95% R.H., non-condensing

Dimensions: 2.7 x 4.6 x 1.0 in. (69 x 118 x 27 mm)

- Accessories:**
- R841 electromechanical relay
 - 50014157-001 air duct temperature sensor
 - 50014156-002 remote room temperature sensor

Compatible Damper/Valve actuators: VC6930, VC6934, VC6936
VC7930, VC7934, VC7936
ML6984
ML7984
ML6410, ML7410
ML6161B2024, MN6105A1011
ML7161A2008, MN7505A2001

Wiring: 18 AWG (1 mm²) wire

- Mounting:**
- directly to drywall
 - single-gang NEMA standard 2-in x 4-in electrical box
 - double-gang NEMA standard electrical box with mounting plate

7. Warranty

Honeywell warrants this product, excluding battery, to be free from defects in the workmanship or materials, under normal use and service, for a period of two (2) years from the date of purchase by the consumer. If at any time during the warranty period the product is determined to be defective or malfunctions, Honeywell shall repair or replace it (at Honeywell's option).

If the product is defective,

- (i) return it, with a bill of sale or other dated proof of purchase, to the place from which you purchased it, or
- (ii) call Honeywell Customer Care at 1-800-468-1502. Customer Care will make the determination whether the product should be returned to the following address: Honeywell Return Goods, Dock 4 MN10-3860, 1885 Douglas Dr N, Golden Valley, MN 55422, or whether a replacement product can be sent to you.

This warranty does not cover removal or reinstallation costs. This warranty shall not apply if it is shown by Honeywell that the defect or malfunction was caused by damage which occurred while the product was in the possession of a consumer.

Honeywell's sole responsibility shall be to repair or replace the product within the terms stated above. HONEYWELL SHALL NOT BE LIABLE FOR ANY LOSS OR DAMAGE OF ANY KIND, INCLUDING ANY INCIDENTAL OR CONSEQUENTIAL DAMAGES RESULTING, DIRECTLY OR INDIRECTLY, FROM ANY BREACH OF ANY WARRANTY, EXPRESS OR IMPLIED, OR ANY OTHER FAILURE OF THIS PRODUCT. Some states do not allow the exclusion or limitation of incidental or consequential damages, so this limitation may not apply to you.

THIS WARRANTY IS THE ONLY EXPRESS WARRANTY HONEYWELL MAKES ON THIS PRODUCT. THE DURATION OF ANY IMPLIED WARRANTIES, INCLUDING THE WARRANTIES OF MERCHANTABILITY AND FITNESS FOR A PARTICULAR PURPOSE, IS HEREBY LIMITED TO THE TWO-YEAR DURATION OF THIS WARRANTY. Some states do not allow limitations on how long an implied warranty lasts, so the above limitation may not apply to you.

This warranty gives you specific legal rights, and you may have other rights which vary from state to state.

If you have any questions concerning this warranty, please write Honeywell Customer Relations, 1985 Douglas Dr, Golden Valley, MN 55422 or call 1-800-468-1502.

8. Customer Assistance

If you have any questions regarding your thermostat, please go to <http://customer.honeywell.com>, or call Honeywell technical hotline at 1-888-245-1051.

By using this Honeywell literature, you agree that Honeywell will have no liability for any damages arising out of your use or modification to, the literature. You will defend and indemnify Honeywell, its affiliates and subsidiaries, from and against any liability, cost, or damages, including attorneys' fees, arising out of, or resulting from, any modification to the literature by you.