



## V404, V504, V524, V804, and VS824 Automatic Valve Operators

**CLICK ANYWHERE on THIS PAGE to RETURN to GAS BURNER & GAS VALVE CONTROLS at [InspectApedia.com](http://InspectApedia.com)**

### INSTALLATION INSTRUCTIONS

#### APPLICATION

These valve operators provide automatic main valve operation in the VB00, VRB00, and VR8440 families of combination gas controls. The operators are interchangeable and can be used either for replacement or to add automatic operation to a C580/CS580 series manual valve. They cannot be used on VR850 series two-stage valves.

The V404, V804, and VSB24 are magnetic operators. They contain an electromagnet that is energized to open the main valve when the thermostat contacts close on a call for heat. The V404/V804/VSB24 replacement operator package includes:

- Operator
- Operator Gasket
- Two Round Regulator Gaskets
- 388589BA Mounting Screws for Standard Capacity Valves

The V504 and V524 are mechanical operators. They use a bulb and bellows assembly filled with a temperature-sensitive liquid to open and close the main valve. The liquid expands and contracts with temperature changes, expanding and contracting the bellows and operating the valve. V504 provides modulating control; V524 provides on-off control. The V504/V524 replacement operator package includes:

- Operator

- Operator Gasket
- 394018 Red Knob and Setscrew
- 394138 Red Knob and Setscrew
- 394075 Black Knob and Setscrew
- 388589BF Mounting Screws for Standard Capacity Valves

The bulb and bellows assembly must be ordered separately; see Table 2.

Longer screws are required to mount the operators on high capacity valves. Obtain four screws locally as follows:

V404, V804, VS824-No. 8-32 UNG, 1-13/16 in. V504, V524-No. 8-32 UNG, 2-3/8 in.

Ambient temperature ratings are as follows:

V404A, V804A, VSB24A-plus 32 F to 175 F [0 C to 80 C]

V404B, V804B, VS824B-minus 40 F to plus 175 F [minus 40 C to plus 80 C].

V504, V524-plus 32 F to 125 F [0 C to 52 C].

The V504 and V524 operators include a pressure regulator; see Table 1 for settings. A separate pressure regulator is used with the V404, V804, VS824 operators.

**Table 1. Automatic Valve Operator Application.**

Operator Model Number	Pressure Regulator Setting				Adjustment	Control	Add-on or Replacement Operator on:
	Min. Rate		Full Rate				
	in. wc	kPa	in. wc	kPa			
V504A	1.2	0.3	3.5	0.87	Limited	Mechanical – temperature-sensitive bulb	C580,C581, V500, V501, V510, V511
V504B	4.0	1.0	11.0	2.7	For LP gas		



**Table 1. Automatic Valve Operator Application. (Continued)**

Operator Model Number	Pressure Regulator Setting				Adjustment	Control	Add-on or Replacement Operator on:
	Min. Rate		Full Rate				
	in. wc	kPa	in. wc	kPa			
V524A	--	--	3.5	0.87	Limited	Mechanical – temperature-sensitive bulb	C580, C581, V520, V521, V530, V531
V524B	--	--	11.0	2.7	For LP gas		
V404	Order separate pressure regulator.					Line voltage	C580, C581, V400, V401, V444, V445, VR400, VR401
V804	Order separate pressure regulator.					24 V	C580, C581, VB00, V801, V844, V845, VRB00, VR801, VR8440, VR8450; V814 Operator on V810, VR810 and V811.
VS824	Order separate pressure regulator.					Powerpile 750 mV	CS580, CS581, VS820, VSB21, VS880, VS897

**Table 2. Replacement Bulb and Bellows Assembly for V504/V524.**

Order No.	Description	Temperature Range	
		F	C
394268-1	Remote Bulb and Bellows	50 to 90	10 to 32
394268-2	Remote Bulb and Bellows	35 to 75	2to 24
394268-3	Remote Bulb, Bellows and Remote Dial (self-index)	50 to 90	10 to 32
394268-4	Remote Bulb, Bellows and Remote Dial (concealed)	50 to 90	10 to 32
394268-6	Remote Bulb, Bellows and Remote Dial (self-index or concealed)	50 to 90	10 to 32

## GENERAL INSTALLATION CONSIDERATIONS

### When Installing This Product...

1. Read these instructions carefully. Failure to follow them could damage the product or cause a hazardous condition.
2. Check the ratings given in the instructions and on the product to make sure the product is suitable for your application.
3. Installer must be a trained, experienced service technician.
4. After installation is complete, check out product operation as provided in these instructions.



### WARNING

Remember that liquefied petroleum (LP) gas is heavier than air and will not vent upward naturally. Do not light pilot or operate electric switches, lights, or appliances until you are sure work area is free of gas. Failure to follow these instructions may result in an explosion.



### CAUTION

1. Disconnect power supply before beginning wiring to prevent electrical shock or equipment damage.
2. Turn gas cock to OFF position.
3. On systems with a 24 V valve operator, NEVER apply a jumper across (or short) the valve coil terminals, even temporarily. This may burn out the heat anticipator in the thermostat.
4. NEVER connect a millivoltage operator to voltage age greater than the operator's rating, as this may destroy the control.

### IMPORTANT

*In a millivoltage system, the entire system is powered by the millivoltage generated by the Powerpile generator. It is important to clean and scrape all wires before connecting. Solder and tape all necessary splices using rosin flux to prevent corrosion. Tighten terminal screws firmly. Total control circuit wiring must not exceed 30 ft [9 m] of 2-wire, 18 gauge cable or 50 ft [15 m] of 2-wire, 16 gauge cable.*

# V404, V804, VS824 INSTALLATION

## REMOVING OLD OPERATOR

1. Disconnect wiring as follows:

24 volt and millivoltage systems:  
Disconnect lead wires at terminal block, marking each lead with the terminal designation as it is removed. On millivoltage systems, also disconnect lead to Pilotstat power unit.

120 volt systems:

Disconnect operator leadwires at junction box. Disconnect conduit at fitting in operator cover and pull leads out of conduit. Remove operator cover to provide access to screws securing valve operator.

2. Remove pressure regulator or blank cover plate. See Figs. 1 and 2. Save regulator or cover plate for reassembly to new operator. Save gasket for blank cover plate; discard pressure regulator gasket.
3. Remove old operator from valve body. Discard old operator and gasket.

## REMOVING ADAPTER CASTING FROM MANUAL VALVE

1. Remove pressure regulator or blank cover plate. Save regulator or cover plate for reassembly to operator. Save gasket for blank cover plate; discard pressure regulator gasket.
2. Remove adapter casting from valve body. See Figs. 1 and 2. Discard casting and gasket.

## INSTALLING NEW OPERATOR

1. Clean operator mounting- location on combination gas control.
2. Position new gasket over the two operator locating pins as shown in Figs 4 and 5.
3. Carefully position the new operator over the gasket and locating pins.

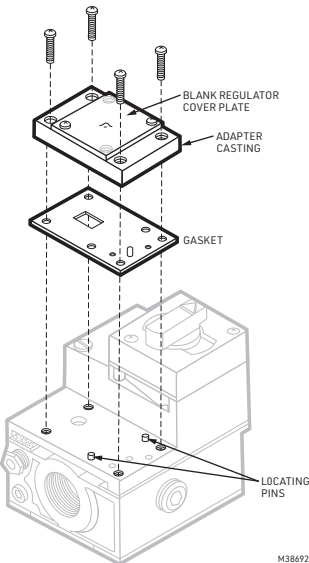

Fig. 1. Removing adapter casting. from standard capacity valve body.

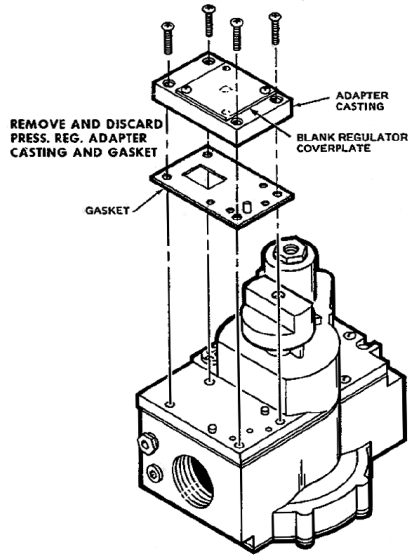

Fig. 2. Removing adapter casting from high capacity valve body.

V5306, V5308, V5309  
REGULATOR GASKET



V5307  
REGULATOR GASKET



Fig. 3. Left gasket is for V5306,8,9; right gasket is for V5307.

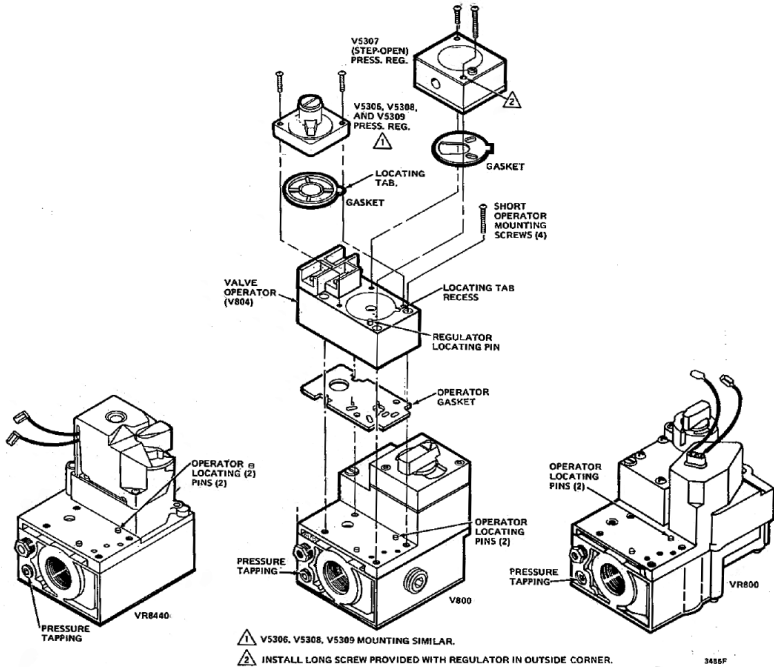

Fig. 4. Mounting operator and pressure regulator on typical combination gas controls.

4. Insert 4 correct-length screws into mounting holes. Use the screws provided for standard capacity gas controls and No. 8-32 UNC, 1-13/16 in. long screws (obtain locally) for high capacity controls. Tighten evenly and securely.

NOTE: On controls equipped with V5307 step-opening pressure regulator, omit the screw on the outside corner. The long screw supplied with the regulator fits into this hole. See Fig. 4.

5. If control has pressure regulator, choose the correct new pressure regulator gasket; see Fig. 3. Press gasket into circle on operator casting, aligning tab with recess in casting. See Fig. 4. Position regulator over gasket and fasten with two screws used originally. For V5307, put the longer screw provided with the regulator in the outside corner hole. Tighten screws evenly and securely.
6. If control does not have pressure regulator, press original gasket into circle on operator casting, aligning tab with recess in casting. Position cover plate with dimple up over locating pin. Install two screws used originally and tighten evenly and securely.

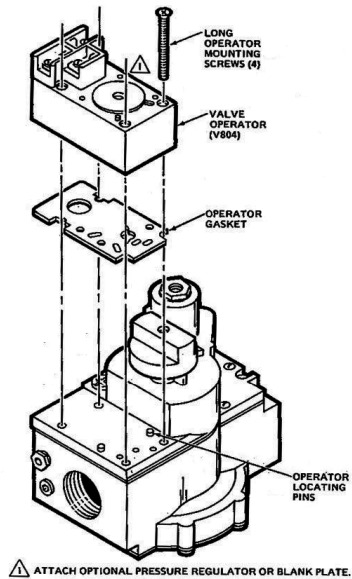

Fig. 5. Mounting operator on a large capacity V800 family combination gas control.

## WIRING

If replacing operator, reconnect wiring as in the original installation. If installing valve operator on manual valve, follow wiring procedure below.

All wiring must comply with local codes and ordinances. Be sure power is off before making wiring connections. On systems with 24 V valve operator, NEVER apply a jumper across (or short) the valve coil terminals, even temporarily. See Fig. 6. This may burn out heat anticipator in thermostat.

### WIRING V804 OPERATOR (24 V SYSTEM)

1. Install transformer, low voltage thermostat, and other controls as required.
2. Connect leads to operator terminals as shown in Fig. 6.
3. Adjust thermostat heat anticipator to the rating stamped on the valve operator.

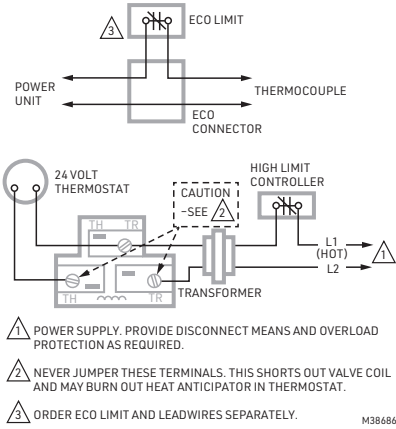

Fig. 6. Typical wiring for 24 V system.

### WIRING V404 OPERATOR (120 V SYSTEM)

1. Install line voltage thermostat and other controls as required.
2. Install junction box within reach of the operator leads. All wiring connections and splices must be inside the junction box.
3. Slip approved conduit connector over operator leads and screw firmly into hole in operator cover.
4. Replace the operator cover, making sure strain relief plate is properly positioned and cover fits flat on operator. Fasten with 2 screws provided.
5. Run flexible conduit between operator and control circuit junction box.
6. Pull operator leads through the conduit and connect the conduit to the connector on the operator cover.
7. Make the mechanical and wiring connections at the junction box. See Fig. 7.

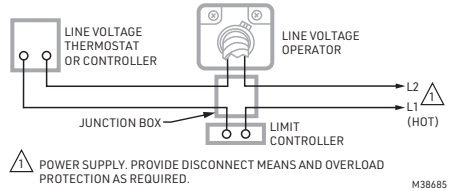

Fig. 7. Typical wiring for 120 V system.

### WIRING VS824 OPERATOR (MILLIVOLTAGE SYSTEM)

NEVER connect a millivoltage operator to line voltage or to a transformer, as this will destroy the control.

Since the entire system is powered by the millivoltage generated by the Powerpile generator, it is important to clean and scrape all wires before connecting. Solder and tape all necessary splices using rosin flux to prevent corrosion. Tighten terminal screws firmly. Total control circuit wiring must not exceed 30 ft [9 m] of 2-wire, 18 gauge cable or 50 ft [15 m] of 2-wire, 16 gauge cable.

1. Install millivoltage thermostat, limit controller (if required) and Powerpile generator according to manufacturer's installation instructions.
2. After Powerpile generator is installed, route generator lead to VS824 operator and connect to terminals labeled "PP." See Fig. 8. Make certain jumper lead from operator to safety shutoff power unit is connected and tightened 1/4 turn beyond finger tight.
3. Route wires from control circuit and connect to the two operator terminals labeled "TH."

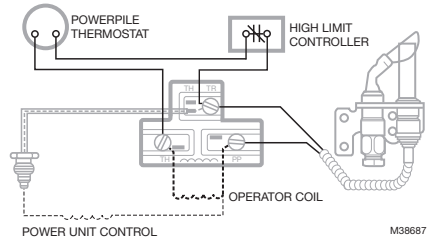

Fig. 8. Typical wiring for millivoltage system.

## V504, V524 INSTALLATION

1. Remove the old operator or adapter casting by loosening the 4 mounting screws and lifting operator or adapter off the main valve body. DO NOT loosen the 5th screw at the edge of the operator. See Figs. 1 and 2.
2. Clean operator mounting location on the combination gas control.
3. Position new gasket over the operator locating pins. See Figs. 10 and 11.
4. New bulb and bellows assembly, if needed, must be ordered separately. See Table 2 for part numbers.
5. Insert bellows in hole in bottom of operator.
6. Run the capillary through the rubber notch in the bottom of the operator and up the groove in the side. See Fig. 9. Tape the capillary in place.
7. Position the new operator on the main valve body.

8. Make sure bellows tip is seated in hole in main valve body and operator is seated on metal locating pins.
9. Insert 4 correct-sized operator mounting screws. Use the screws provided for standard capacity valves and No. 8-32 UNC, 2-3/8 in. long screws (obtain locally) for high capacity valves.
10. If the bulb and bellows assembly is new, follow the instructions provided with the assembly to install the bulb and the remote dial assembly, if used.

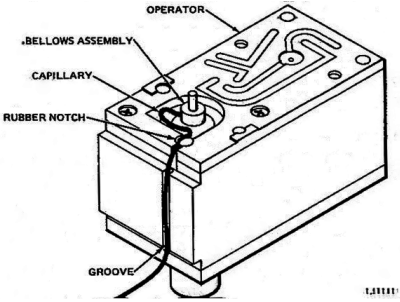

Fig. 9. Form capillary smoothly and without crimping to fit in hole in operator.

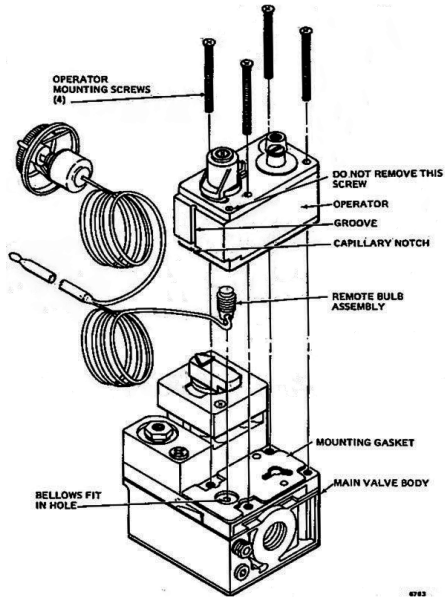

Fig. 10. Mounting the V504 and V524 operator on a standard capacity valve (Cabinet-mounted dial shown).

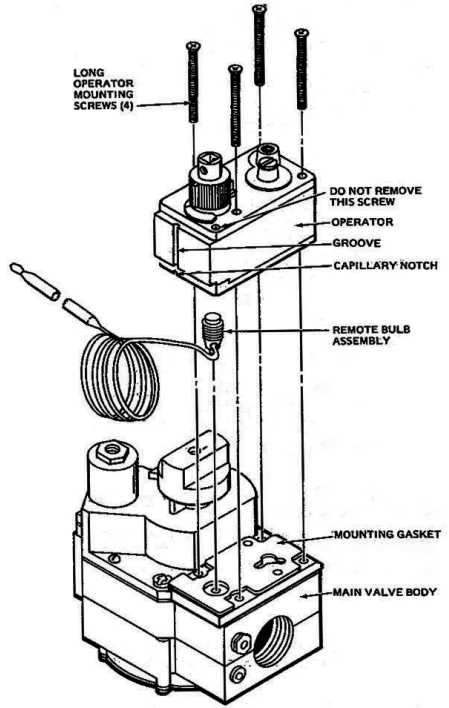

Fig. 11. Mounting the V504 or V524 operator on a high capacity valve (Direct-mounted dial shown).

## CALIBRATE OPERATOR AND INSTALL SETTING KNOB

Calibration is necessary whenever the V504, V524, operator or the bulb and bellows assembly is replaced. During calibration, refer to Table 3 to correlate room temperature with the numbers on the setting dial.

**Table 3. Temperature Dial Setting Correlation.**

Setting Dial Number	1	2	3	4	5	6	7	8	9
Approximate Temperature	35	40	45	50	55	60	65	70	75
35 F-75 F [2 C-24 C]-Range	[2]	[4]	[7]	[10]	[13]	[16]	[18]	[21]	[24]
50 F-90 F [10 C-32 C] Range	50	55	60	65	70	75	80	85	90
	[10]	[13]	[16]	[18]	[21]	[24]	[27]	[29]	[32]

### V504/V524 WITH DIAL ON OPERATOR

1. Light pilot as described under Pilot Lighting Procedure. Place a reliable thermometer near the temperature sensing bulb to measure room temperature. Wait 5-10 minutes.
2. If the main burner is on, turn the calibration knob clockwise just until the burner goes off. If the main burner is off, turn the calibration knob counterclockwise just until the burner goes on.
3. Choose one of the red setting dials. Use Part No. 394018 when the knob can be reached and turned directly; use Part No. 394138 when a rod and handle will be installed on the dial.
4. Slide the dial over the knob, so that the dial number corresponding to the room temperature aligns with the indicator on the valve body. See Table 3 and Fig. 12.
5. Insert the screw supplied with the dial and tighten firmly while holding the dial in place.
6. If using 394138 Dial, insert 1/4 in. rod (obtain locally) into end of dial. Align hole in end with hole in dial sleeve. Fasten with cotter pin.
7. Turn dial to desired setting, making sure the calibration knob is turning with the dial. If not, repeat steps 2-5.

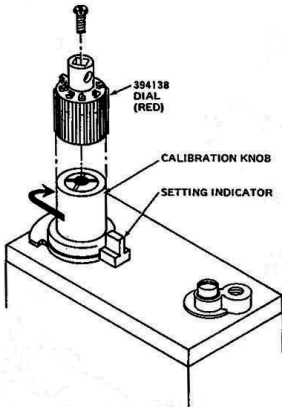

**Fig. 12. Calibrating V504/V524 with dial on operator.**

### V504/V524 WITH DIAL MOUNTED ON CABINET.

1. Light pilot as described under Pilot Lighting Procedure. Place a reliable thermometer near the temperature sensing bulb to measure room temperature. Wait 5-10 minutes.
2. Set the remote dial to the number corresponding with the bulb temperature. See Table 3 and Fig. 13.

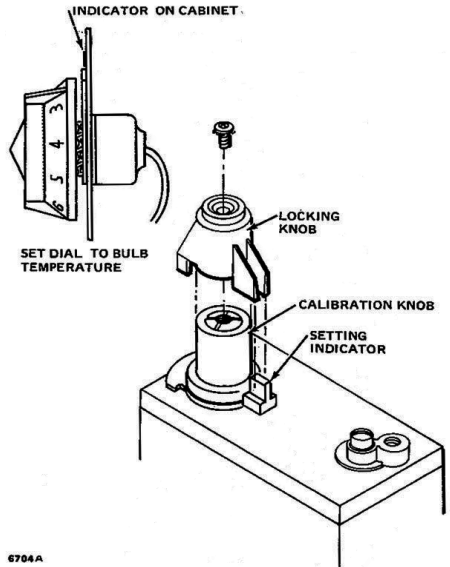

**Fig. 13. Calibrating V504/V524 with dial mounted on cabinet.**

3. If the main burner is on, turn the calibration knob slowly clockwise until the burner goes off. If the main burner is off, turn the calibration knob slowly counterclockwise until the burner goes on.
4. Slide the black locking knob over the calibration knob with the setting indicator in the notch. See Fig. 13. Insert the screw supplied with the dial and tighten firmly.
5. Set remote dial to desired setting.

## STARTUP AND CHECKOUT

### GAS COCK SETTINGS

The Lite-Rite gas cock knob has three settings:

OFF, which prevents any gas from passing through valve to either main or pilot burner.

PILOT, which permits gas to flow to pilot burner only

ON, which permits gas to flow to both main and pilot burners when the thermostat calls for heat.

### PILOT LIGHTING PROCEDURE

1. Slightly depress Lite-Rite gas cock knob and turn clockwise to OFF. Wait 5 minutes for all unburned gas to vent.



### WARNING

**Remember that liquefied petroleum (LP) gas is heavier than air and will not vent upward naturally. Do not light pilot or operate electric switches, lights, or appliances until you are sure work area is free of gas. Failure to follow these instructions may result in an explosion.**

2. Turn the Lite-Rite knob to PILOT, depress it completely, and light the pilot burner while holding it down. Hold the knob down about one minute. If the pilot goes out when the knob is released, repeat steps 1 and 2.

3. Turn the knob to ON, and set the thermostat or the dial on the V504/V524 operator above room temperature to turn on main burner.

### GAS LEAK TEST



### WARNING

**DO NOT OMIT THIS TEST**

**With main burner in operation, paint gasket lines between operator, pressure regulator or cover plate, and main valve with rich soap and water solution. Bubbles indicate gas leakage. To stop leak, tighten assembly screws or, if necessary, replace gasket.**

### CHECKOUT

Place the system into operation, and observe through one complete cycle to be sure all controls function properly. With V504/V524 operator, make sure burner comes on when room temperature drops below the dial setting, and the system maintains the desired temperature.



Resideo Technologies, Inc.  
1985 Douglas Drive North, Golden Valley, MN 55422  
1-800-468-1502

www.resideo.com 95-6999-08 M.S. Rev. 09-21 | Printed in United States