



L6006 and L6007 Aquastat® Controllers

INSTALLATION INSTRUCTIONS

APPLICATION

These Aquastat® Controllers operate in response to temperature changes in hydronic heating systems. They provide spdt switching for three-wire applications.

The L6006A,B, and L6007A combine low or high limit and circulator control; L6006C combines circulator control with low and high limit.

The L6006A,B are for horizontal insertion; the A model uses an immersion well; the B model uses a capsule compression fitting for direct immersion. The L6006C is for horizontal or vertical surface mounting. The L6007A is for horizontal or vertical insertion using an immersion well.

If immersion well or capsule compression fitting must be ordered, refer to form 68-0040, Wells and Fittings for Temperature Controllers, for part numbers and ordering information.

Table 1. Electrical Ratings (A).

	120 Vac	240 Vac
Full Load	8	5.1
Locked Rotor	48	30.6
Inductive Current	0.25 at 1/4 to 12 Vdc	

INSTALLATION

When Installing this Product...

1. Read these instructions carefully. Failure to follow them could damage the product or cause a hazardous condition.
2. Check the ratings given in the instructions and on the product to make sure the product is suitable for your application.
3. Installer must be a trained, experienced service technician.
4. After installation is complete, check out product operation as provided in these instructions.

WARNING

CAN CAUSE PROPERTY DAMAGE, SEVERE INJURY OR DEATH.

This product is intended for use only in systems with a pressure relief valve.



CAUTION

Disconnect power supply before connecting wiring to prevent electrical shock or equipment damage.

IMPORTANT

Controller can be used with or without immersion well. If used, well must snugly fit sensing bulb for good thermal response. Bulb should be inserted until it rests against bottom of well, and then held there while the tubing clamp is tightened.

NOTE: Some models have an adjustable tubing length to 3 in. (76 mm). In these models, extra tubing inside the case can be pulled out, if needed. See Fig. 1.

The manufacturer usually provides a tapping for insertion of the controller sensing element. This tapping is located at a point where typical water temperature can be measured.

Depending on model, the element is inserted in an immersion well or directly immersed through a capsule compression fitting.

Follow the instructions furnished by the system manufacturer, if available; otherwise, refer to the appropriate following procedure.

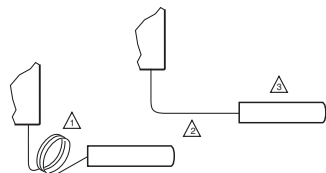

CAUTION:
EXCESSIVE HANDLING OR SHARP BENDS
CAN DAMAGE THE CAPILLARY.

⚠ SENSING ELEMENT IS FACTORY FORMED FOR 1.5 INCH INSULATION WELL ASSEMBLIES.

⚠ FOR 3 INCH INSULATION WELL ASSEMBLIES, PULL OUT SUFFICIENT CAPILLARY TO ASSURE THAT THE CAPSULE BOTTOMS IN THE WELL.

⚠ STRAIGHTEN CAPILLARY SUFFICIENTLY SO IT DOES NOT INTERFERE WITH INSERTING THE CAPSULE INTO THE WELL.

M882

Fig. 1. Adjusting the capillary length.



95-5973-04

Installing Immersion Well Models (L6006A, L6007A)

On existing installation, shut off the power and remove the old control. If the old immersion well appears suitable, and the adapter clamp on the Aquastat® Controller fits the old well spud, do not replace.

1. If the system is filled, drain system to a point below the boiler tapping.
2. Remove plug (or old well) from boiler tapping.
3. Install the immersion well included with the controller. If boiler tapping is greater than 1/2 in., use a reduction fitting to adapt the boiler opening to the 1 in. threads that are standard with the well or fitting. Fittings with 3/4 in. threads are also available.
4. Fill the system. Make sure that the well is screwed in tightly enough to prevent leakage. Do not tighten after controller is secured to well because of possible excessive force on the case.
5. Loosen screw (at top of case, above scale setting), and remove cover. Loosen two screws that secure adapter clamp. See Fig. 2.
6. Insert the sensing element into the immersion well.
7. Fasten the case of the Aquastat® Controller to the well with the adapter clamp. Make certain that the clamp is properly positioned over the groove of the well spud. Also, be sure the flange at the opening of the well fits snugly into the opening of the case. The sensing element bulb must bottom in the well.

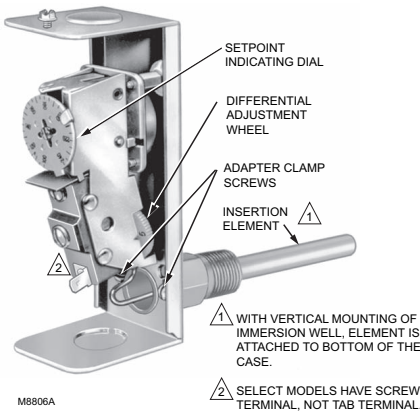

Fig. 2. Internal view of L6006A,B (L6006C and L6007 are similar in appearance).

Installing Direct Immersion Models (L6006B)

Install fitting in boiler tapping as follows:

1. Be sure sealing washer is in place as shown in Fig. 3. Make sure that spud of capsule compression fitting is screwed in tightly enough to prevent leaking.
2. Insert immersion bulb (sensing element) through capsule compression fitting. Adjust the adapter clamp so that it fits over the groove at the opening of the capsule compression fitting.
3. Tighten adapter clamp screws so the Aquastat® Controller is firmly attached to the capsule compression fitting.

Installing Surface-mounted Model (L6006C)

⚠ CAUTION

- Do not replace immersion type Aquastat® Controller with strap-on Aquastat® Controller.
- When mounting the L6006C, do not secure draw nut so tight that retainer clamp could collapse tubing.

NOTE: When mounting the L6006C on piping, use 1 in. (25.4 mm) diameter or larger pipe for accurate temperature sensing. Remove any insulation from the pipe. Thoroughly scrape off all scale, rust, or paint. Mount the controller using the adjustable bracket furnished.

The L6006C is designed for surface mounting on piping or tanks. Mount the L6006C directly on the tank surface using the adjustable mounting bracket as shown in Fig. 4. The control can be mounted in any position. (If mounting the L6006C on piping, see NOTE above.)

WIRING

Disconnect power supply before connecting wiring to prevent electrical shock or equipment damage. All wiring must comply with local electrical codes and ordinances.

Fig. 5 and 6 show typical wiring diagrams of Aquastat® Controllers used in heating systems.

When the W terminal on the device being replaced is a 1/4 in. tab terminal, use the existing wiring harness terminals to install the replacement device. When the W terminal on the device being replaced is a screw terminal, connect the provided wire harness adapter on the 1/4 in. tab terminal of the replacement device. Connect the existing wire to the adapter harness using the provided wire nut.

OPERATION

For proper selection of settings, follow the boiler manufacturer recommendations.

High limit controller—shuts off burner when water temperature exceeds high limit setting. Burner restarts when temperature drops to high limit setting, less differential.

Low limit controller—maintains minimum boiler temperature for domestic hot water. Turns on burner at temperature setting, minus differential.

Circulator controller—prevents circulation of water that is not hot enough. Breaks circulator circuit at temperature setting minus differential; remakes the circuit when the temperature setting is reached.

Switching action is as follows:

Upon a drop in boiler water temperature (to dial setting, less differential), makes R to B burner contact; breaks R to W contact, preventing circulator operation. Upon a rise in boiler water temperature (to dial setting), breaks R to B burner contact, makes R to W circulator contact.

ADJUSTMENT

Set the differential to correspond with the boiler manufacturer recommendations. To adjust models with adjustable differential, rotate the wheel on the back of the snap switch until the desired reading is aligned with the V notch in the frame. The wheel provides an adjustment from 5°F to 30°F (3°C to 17°C). Replace the cover on the Aquastat® Controller.

Adjust control point to correspond with the boiler manufacturer recommendations. To adjust, insert a screwdriver in the slotted screw type head located beneath the window in the cover. Turn the scale to the desired control point.

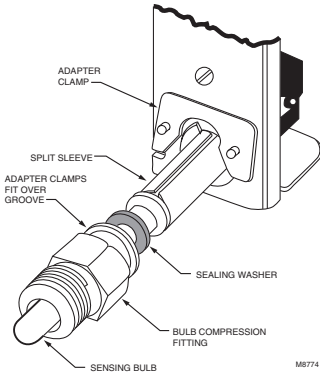

Fig. 3. Direct immersion model with bulb compression fitting partially removed.

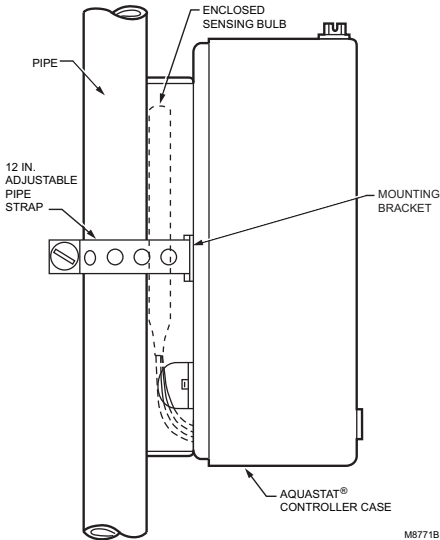

Fig. 4. Mounting L6006C on pipe or tank.

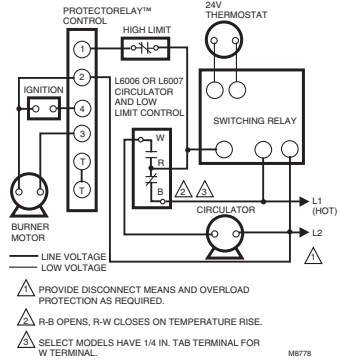

Fig. 5. Typical wiring hookup using the L6006 or L6007 for low limit and circulator control in oil-fired hydronic system.

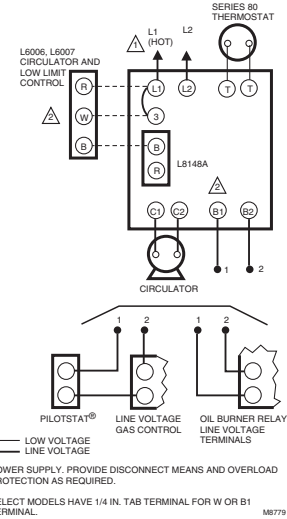

Fig. 6. Typical wiring hookup using L6006 and L6007 with L8148A.

CHECKOUT

Check to make certain that the Aquastat® Controller is installed and adjusted properly. Put the system into operation and observe the action of the device through several cycles to make certain that it provides proper low and/or high limit and circulator control.



Resideo Technologies, Inc.
1985 Douglas Drive North, Golden Valley, MN 55422
1-800-468-1502

www.resideo.com 95-5973-04 M.S. Rev. 04-20 | Printed in United States