

WIRING DIAGRAM and INSTRUCTIONS

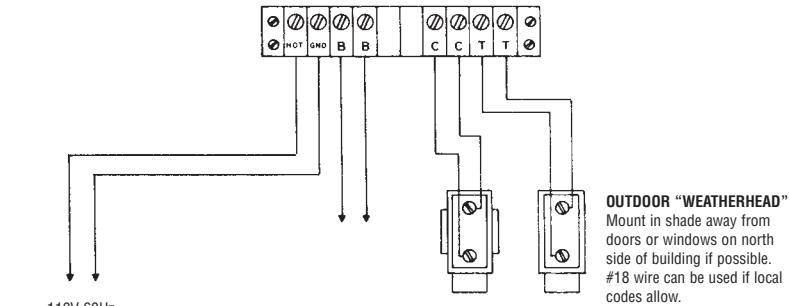

SOLID STATE HEATING SYSTEM SENSOR

X-Y-Z setting must be adjusted to turn on amber light when heat has reached farthest point of heating system.

#18 wire can be used if local codes allow



OPERATING INSTRUCTIONS

MODEL EPU-CH And MODEL EPU
UL LISTED FILE #E-60760



WARNING: The HEAT-TIMER Heating Control Systems are strictly operating controls; under no circumstances should they be used as primary limit or safety controls. Each piece of equipment must have its own certified limit and safety controls required by local codes. These are the responsibility of the installing contractor who must verify proper operation and correct any safety problems prior to proceeding with the installation of these HEAT-TIMER Systems



20 New Dutch Lane, Fairfield, N.J. 07004 • FAX 973-575-4004 • FAX 973-575-4052 • <http://www.heat-timer.com>



CONTROL PANEL

The Heat-Timer® Electronic Weather Actuated Heating Control Panel is available in two models: Model EPU and Model EPU-CH. Both panels are identical except model EPU-CH includes an added "Thermal Lockout" feature to prevent overheating and is recommended for steam systems with cast iron radiation (Either model is available with 30 or 60 minute cycle times which must be factory specified.)

Both models are used with the same solid state sensors: the Weatherhead and the Indoor Element (both described below).

OUTDOOR SENSOR (P/N 904002)

(WEATHER HEAD)

The Weather Head is extremely sensitive to temperature. It signals to the Control panel changes in temperature. Based on this signal the Control Panel, by means of a sensitive electronic system, sets up the heating program. The Weather Head has no moving parts, no electrical contacts or adjustments. (Once installed it will last indefinitely and will require no further attention). It should be installed at the end of conduit piping on the outside of the building at least 8 feet from the ground and offset at least 4 inches from the building.

IMPORTANT: The Weather Head must not be placed where it will be affected by heat or air currents emanating from open windows and doors or exhaust fans. It must not be placed where it will be affected by the sun. Follow the same rule in locating the Weather Head as would be used to locate a thermometer for the purpose of reading true outdoor temperature.



HEATING SYSTEM SENSOR (P/N 904005)

The Heating System Sensor (Indoor Element) must be installed at a location which indicates when steam has completely filled the Heating System and which cools at a rate similar to the Entire System. Typical locations include:

- 1) The Farthest Radiator from the boiler (the last to get heat).
- 2) The Farthest Return Riser.

The Indoor Element signals to the Panel when heat has circulated to the farthest point of the heating system and therefore the timing of the heat cycle can begin. Until this signal is received by the Control Panel this timing will not start. The best way to adjust the Indoor Element is to start up the Burner after the heat has been off long enough for the system to cool down. Turn Indoor Element Adjust Dial fully clockwise. Go to the radiator farthest from the Boiler or the radiator that is known to be the hardest to heat. When this radiator begins to get hot rotate the "Indoor Element Adjust Dial" on the panel counter clockwise until the amber light on Control Panel goes on. In that way there is the assurance that complete heat circulation has been established when the timing cycle starts.

FOR MODEL EPU-CH ONLY

The indoor element also signals a lockout function to the panel at the end of the off portion of the heat cycle if the indoor element setting is still satisfied. The Boiler will not re-start until the return pipe cools 28°F below the Indoor Element Adjustment setting.



MODEL EPU (only)

SIGNAL LIGHTS and what they mean

- ▶ **RED "ON" – AMBER "OFF" BB Contact Closed**
indicates weather calls for heat-heat circulation not yet established
- ▶ **RED "ON" – AMBER "ON" BB Contact Closed, Heat Circulation established, indicates "ON" period of cycle is being timed**
- ▶ **RED "OFF" AMBER "ON" BB Contact Open**
indicates "OFF" period of cycle is being timed
- ▶ **RED "OFF" AMBER "OFF" BB Contact Open**
indicates either (1) outdoor temperature is above setting of outdoor thermostat, or (2) program clock is in "OFF" period

HEAT CYCLE CHART (30 minute cycle)

OUTDOOR TEMPERATURE

HEAT ADJUSTMENT

	-20°	-15°	-10°	-5°	0°	5°	10°	15°	20°	25°	30°	35°	40°	45°	50°
A-	17	16	15	14	13	12	11	10	9	8	7	6	5	4	3
B-	19	18	17	16	15	14	13	12	11	10	9	8	7	6	5
C-	22	20	19	18	17	16	15	14	13	12	11	10	9	8	7
D-	23	22	21	20	19	18	17	16	15	14	13	12	11	10	9
E-	25	24	23	22	21	20	19	18	17	16	15	14	13	12	11
F-	27	26	25	24	23	22	21	20	19	18	17	16	15	14	13
G-	C	C	C	26	25	24	23	22	21	20	19	18	17	16	15
H-	C	C	C	C	C	26	25	24	23	22	21	20	19	18	17
I-	C	C	C	C	C	C	C	26	25	24	23	22	21	20	19
J-	C	C	C	C	C	C	C	C	C	26	25	24	23	22	21

The above chart shows the approximate number of minutes of heat per 1/2 hr after Heat Circulation has been established (Red "ON" and Amber "ON"). "C" means Continuous Operation.

MODEL EPU-CH (only)

• SIGNAL LIGHTS and what they mean

- ▶ **RED "ON" – AMBER "OFF" – WHITE "OFF" BB Contact Closed** indicates weather calls for heat-heat circulation not yet established
- ▶ **RED "ON" – AMBER "ON" – WHITE "ON" BB Contact Closed, Heat Circulation established, indicates "ON" period of cycle being timed**
- ▶ **RED "OFF" – AMBER "ON" – WHITE "ON" BB Contact Open** indicates "OFF" period of cycle is being timed heat still established
- ▶ **WHITE "ON" – RED "OFF" – AMBER "OFF" BB Contact Open, cycle over indicates a "HOT" return pipe. The Red Light will not come on until the surface temperature of the return pipe drops 28° below the setting of the indoor element.**
- ▶ **RED "OFF" – AMBER "OFF" – WHITE "OFF" BB Contact Open** indicates either (1) outdoor temperature is above setting of outdoor thermostat, or (2) program clock is in "OFF" period

HEAT CYCLE CHART (60 minute cycle)

OUTDOOR TEMPERATURE

-20° -15° -10° -5° 0° 5° 10° 15° 20° 25° 30° 35° 40° 45° 50°

	-20°	-15°	-10°	-5°	0°	5°	10°	15°	20°	25°	30°	35°	40°	45°	50°
A-	34	32	30	28	26	24	22	20	18	16	14	12	10	8	6
B-	38	36	34	32	30	28	26	24	22	20	18	16	14	12	10
C-	42	40	38	36	34	32	30	28	26	24	22	20	18	16	14
D-	46	44	42	40	38	36	34	32	30	28	26	24	22	20	18
E-	50	48	46	44	42	40	38	36	34	32	30	28	26	24	22
F-	54	52	50	48	46	44	42	40	38	36	34	32	30	28	26
G-	C	C	C	52	50	48	46	44	42	40	38	36	34	32	30
H-	C	C	C	C	C	52	50	48	46	44	42	40	38	36	34
I-	C	C	C	C	C	C	C	52	50	48	46	44	42	40	38
J-	C	C	C	C	C	C	C	C	C	52	50	48	46	44	42

The above chart shows the approximate number of minutes of heat per hour after Heat Circulation has been established (Red "ON" and Amber "ON"). "C" means Continuous Operation.

IMPORTANT!

FOR MODEL EPU ONLY

A direct acting (break on rise) aquastat, vaporstat or pressuretrol may be used instead of the solid state indoor element. When using either of the above rotate the "Indoor Element Adjustment Dial" to "X+2" setting.

NOTE: AN AQUASTAT, VAPORSTAT OR PRESSURE TROL CAN NOT BE UTILIZED ON MODEL EPU-CH. ONLY THE SOLID STATE SENSOR SUPPLIED.

DAY THERMOSTAT DIAL



The Day Thermostat Dial should be set at the outdoor temperature above which no heat is required. When the outdoor temperature is below the setting of this dial the amount of heat provided each hour will be regulated by the Heat-Timer and will be proportional to the weather and the specific heat requirements of the building.

The fact that the Heat-Timer is not calling for heat will in no way affect the supply of domestic hot water as this is regulated by the Aquastat on the Boiler and is entirely independent of the Heat-Timer Control System.

CALIBRATING CONTROL

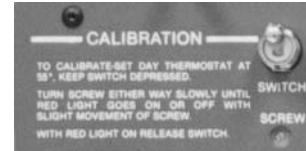

To calibrate: set Day Thermostat Dial at 55°. Depress calibrating switch and hold. While calibrating switch is depressed, turn calibrating screw very slowly to right or left until Red light goes ON or OFF with very slight movement. With RED light on, release calibrating switch. The Heat-Timer Day Thermostat is now calibrated for any temperature setting on the Day Thermostat Dial.

NOTE: This adjustment is very critical and must be done carefully.

NOTE: EPU control cannot be calibrated while control is in timing cycle. Rotate cycle cam to center of "V" slot which is the zero position to deactivate cycle.

NOTE: EPU-CH control cannot be calibrated while control is in timing cycle and/or the White light is on. Rotate Indoor Element Adjustment Knob fully clockwise to de-energize White light. To deactivate timing cycle see note above.

AUTOMATIC-MANUAL SWITCH



When in the "AUTOMATIC" position the entire heating program is controlled by the Heat-Timer. This switch should be in the "AUTOMATIC" position at all times. When the switch is in the "MANUAL" position the Heat-Timer is by-passed completely and the heating system can be operated manually, independent of the Heat-Timer Control.

If trouble develops in the heating system, it is a simple matter to isolate the fault by means of this switch to the burner safety control or the Heat-Timer equipment. Snap the switch to manual and if the burner starts and operates normally the trouble is probably in the Heat-Timer Control. If it does not start, the trouble is then in the burner circuit or associated equipment.

HEAT ADJUSTMENT

SUMMER-WINTER SWITCH



This switch must be in the "WINTER" position during the heating season. At the end of the heating season the switch should be changed to the "SUMMER" position. Where domestic hot water is heated by the heating boiler the Aquastat will control the hot water supply during the summer period. The position of the SUMMER-WINTER Switch does not in any way affect the production of hot water.

HEAT ADJUSTMENT DIAL



NOTE: The outer concentric knob determines the day heat adjustment setting and the inner knob determines the night heat adjustment setting.

The Heat Adjustment Dial provides a simple and positive means to increase or decrease the heat level of the building.

This dial has a very wide range of control which enables the Heat-Timer to meet the specific heat requirement of practically any building.

During the heating season, it should not be necessary to make any change in heat adjustment to compensate for any change in outdoor temperature, because the Heat-Timer automatically varies the heating program to meet these weather changes.

For example: If the heat level in a building is satisfactory when the outdoor temperature is 40° with the heat adjustment set at D the heat level will remain the same even though the outdoor temperature changes to a lower temperature or a higher temperature. It is suggested that at the outset the Heat Adjustment Dial be placed at D and increased or decreased 1/2 **index letter at a time until the satisfactory indoor temperature level has been attained.**

NOTE: Certain buildings may require a re-adjustment in the Spring and Fall to insure total comfort.

NIGHT HEAT THERMOSTAT



When the Night Heat Thermostat is set OFF there will be no heat provided during the night OFF period.

If some heat is desired during the night OFF period or if protection against freeze up is important set the Night Heat Thermostat dial at the outdoor temperature below which heat is desired. This dial can be set for any outdoor temperature between 0 and 50°. The night heat cycle like the day heat cycle is electronically controlled and the quantity of heat will depend on how much lower the outdoor temperature is than the temperature setting of the Night Heat Thermostat.



Optional, Weekend Omitting Device when fitted

Set wheel for correct day of the week. To omit regular "ON" operation, insert screw on segment corresponding to day operation is not desired.

PROGRAM CLOCK



The Program Clock controls the beginning and end of the heating day.

The light portion of the clock face represents the morning and afternoon (6 a.m. to 6 p.m.). The dark portion represents the evening and night (6 p.m. to 6 a.m.). The arrow located directly beneath the time dial face that is marked "TIME" must always point to the correct time of day. To adjust dial for correct time of day turn dial in clockwise direction **only** (as indicated by arrows on dial), never turn counter clockwise or in opposite direction of arrow.

TRIP LEVER

The TRIP LEVER can be operated manually. When no heat is desired during the day. Push TRIP LEVER to "NIGHT" position. To resume heating push lever to "DAY" position.

SWITCH LUGS

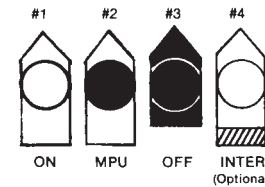

#1 "ON" – The light colored lug should be placed on the dial at the time "day" heating should begin. This lug provides an approximate 55 minute morning heat-up period.

#2 "MORNING PICK-UP" – The light lug with the dark screw should be placed next to and to the right of the "On" lug. This lug provides an additional 55 minute morning heat-up period.

#3 "OFF" – The dark lug with dark screw should be placed on the dial at the time when "day" heating should end.

#4 "INTERMEDIATE" – The light colored lug (with tapered end) and light screw is available separately as an option. It will switch the control from "night" to "day" but without a morning heat-up period.

HEAT CYCLES

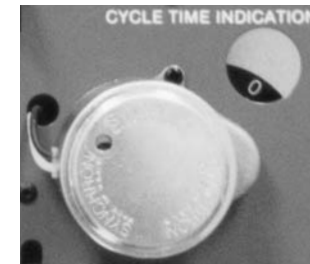

The -60 model total cycling time is one hour. The heat "on" portion is determined by the outdoor temperature. The colder the weather, the longer will be the "on" portion of the cycle. The "off" portion of the cycle is the difference between the "on" portion and one hour. For example, if the "on" portion is 32 minutes, the "off" portion will be 28 minutes.

30 and 60 minutes cycle times are factory specified options. The most economical heating will be obtained by using the one hour cycle on steam systems with cast iron radiation. For steam heating systems with fin type radiation or air handling units a 30 minute cycle time is recommended.