



Universal Fire Tube

Floor and Wall Mount Boilers

Installation

Start-Up

Maintenance

Parts

Warranty

UFT-80 / 100 / 120 / 140 / 175 / 199* Models

* "F" Denotes Floor Model; "W" Denotes Wall Mount Model, "LP" Denotes Propane Gas

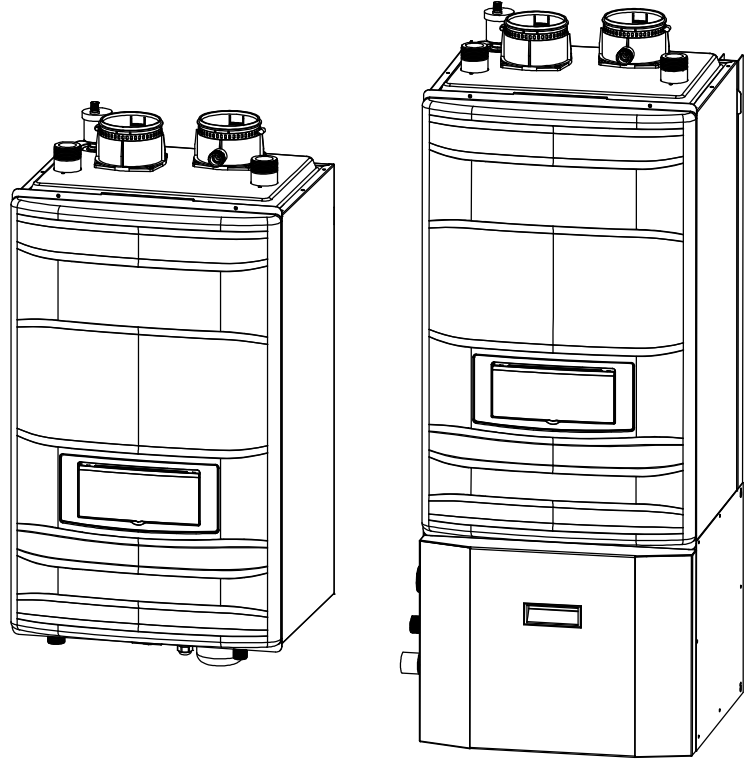

This Manual For Use With Boilers Manufactured Before January 1, 2020



Heat Exchanger Bears the ASME "H" Stamp



! DANGER

This manual must only be used by a qualified installer / service technician. Read all instructions in this manual before installing. Perform steps in the given order. Failure to do so could result in substantial property damage, severe personal injury, or death.

! WARNING

Improper installation, adjustment, alteration, service, or maintenance could void product warranty and cause property damage, severe personal injury, or death.

California Proposition 65 Warning: This product contains chemicals known to the State of California to cause cancer, birth defects, or other reproductive harm.

NOTICE

The manufacturer reserves the right to make product changes or updates without notice and will not be held liable for typographical errors in literature.

NOTE TO CONSUMER: PLEASE KEEP ALL INSTRUCTIONS FOR FUTURE REFERENCE.

! WARNING

WARNING: If the information in these instructions is not followed exactly, a fire or explosion may result causing property damage, personal injury or death.

- Do not store or use gasoline or other flammable vapors and liquids in the vicinity of this or any other appliance.

WHAT TO DO IF YOU SMELL GAS

- Do not try to light any appliance.
- Do not touch any electrical switch; do not use any phone in your building.
- Immediately call your gas supplier from a neighbor's phone. Follow the gas supplier's instructions.
- If you cannot reach your gas supplier, call the fire department.
- Installation and service must be provided by a qualified installer, service agency or the gas supplier.



Improper installation, adjustment, alteration, service, or maintenance can cause injury, property damage, or death. Refer to this manual. Installation and service must be performed by a qualified installer, service agency, or gas supplier.

FOR YOUR SAFETY READ BEFORE OPERATING

! WARNING : If you do not follow these instructions exactly, a fire or explosion may result causing property damage, personal injury or loss of life."

- A. This appliance does not have a pilot. It is equipped with an ignition device which automatically lights the burner. Do not try to light the burner by hand.
- B. **BEFORE OPERATING** smell all around the appliance area for gas. Be sure to smell next to the floor because some gas is heavier than air and will settle on the floor.
- WHAT TO DO IF YOU SMELL GAS**
- Do not touch any electric switch; do not use any phone in your building.
 - Do not try to light any appliance.
 - Immediately call your gas supplier from a neighbor's phone. Follow the gas supplier's instructions.
 - If you cannot reach your gas supplier, call the fire department.
- C. Use only your hand to push in or turn the gas control knob. Never use tools. If the knob will not push in or turn by hand, don't try to repair it, call a qualified technician. Force or attempted repair may result in a fire or explosion.
- D. Do not use this appliance if any part has been under water. Immediately call a qualified technician to inspect the appliance and to replace any part of the control system and any gas control which has been under water.

OPERATING INSTRUCTIONS

1. STOP! Read the safety information above on this label.
2. Set the thermostat to lowest setting.
(Never use Water Heater unless it is completely filled with water.)
3. Turn OFF electrical power supply to the Water Heater.
4. Don't try to light the burner by hand.
5. Turn gas shut-off valve clockwise  to "OFF" position. Do not force.
6. Wait five (5) minutes to clear out any gas. If you then smell gas, STOP! Follow step "B" above on this label. If you don't smell gas, go to the next step.
7. Turn manual gas shut-off valve counterclockwise  to "ON" position.
8. Turn ON electrical power to the appliance.
9. Wait until default temperature (125°F) is displayed. Set desired water temperature. Turn on hot water faucet.
10. Set thermostat to desired setting.
11. If the appliance will not operate, follow the instructions "To Turn Off Gas To Appliance" and call your service technician or gas supplier.

TO TURN OFF GAS TO APPLIANCE

1. Set the thermostat to lowest setting.
2. Turn off all electric power to the appliance if service is to be performed.
3. Turn manual gas shutoff valve to "OFF".

SPECIAL ATTENTION BOXES

The following defined terms are used throughout this manual to bring attention to the presence of hazards of various risk levels or to important product information.

! DANGER

DANGER indicates an imminently hazardous situation which, if not avoided, will result in serious personal injury or death.

! WARNING

WARNING indicates a potentially hazardous situation which, if not avoided, could result in personal injury or death.

! CAUTION

CAUTION indicates a potentially hazardous situation which, if not avoided, may result in moderate or minor personal injury.

CAUTION

CAUTION used without the safety alert symbol indicates a potentially hazardous situation which, if not avoided, may result in property damage.

NOTICE

NOTICE is used to address practices not related to personal injury.

Foreword

This manual is intended to be used in conjunction with other literature provided with the boiler. This includes all related control information. It is important that this manual, all other documents included in this system, and additional publications including the *National Fuel Gas Code - ANSI Z223.1* (latest versions), be reviewed in their entirety before beginning any work.

Installation should be made in accordance with the regulations of the Authority Having Jurisdiction, local code authorities, and utility companies which pertain to this type of water heating equipment.

Authority Having Jurisdiction (AHJ) – The AHJ may be a federal, state, local government, or individual such as a fire chief, fire marshal, chief of a fire prevention bureau, labor department or health department, building official or electrical inspector, or others having statutory authority. In some circumstances, the property owner or his/her agent assumes the role, and at government installations, the commanding officer or departmental official may be the AHJ.

NOTE: The manufacturer reserves the right to modify product technical specifications and components without prior notice.

For the Installer

This boiler must be installed by qualified and licensed personnel. The installer should be guided by the instructions furnished with the boiler, and by local codes and utility company requirements. In the absence of local codes, preference should be given to the *National Fuel Gas Code - ANSI Z223.1*, latest version.

Installations Must Comply With:

Local, state, provincial, and national codes, laws, regulations, and ordinances.

The latest version of the *National Fuel Gas Code, ANSI Z223.1*, from American Gas Association Laboratories, 8501 East Pleasant Valley Road, Cleveland, OH 44131.

In Canada - *CGA No. B149* (latest version), from Canadian Gas Association Laboratories, 55 Scarsdale Road, Don Mills, Ontario, Canada M3B 2R3. Also, *Canadian Electrical Code, C 22.1*, from Canadian Standards Association, 5060 Spectrum Way, Suite 100, Mississauga, Ontario, Canada L4W 5N6.

The latest version of the *National Electrical Code, NFPA No. 70*.

NOTE: The gas manifold and controls met safe lighting and other performance criteria when undergoing tests specified in *ANSI Z21.10.3* - latest edition.

⚠ DANGER

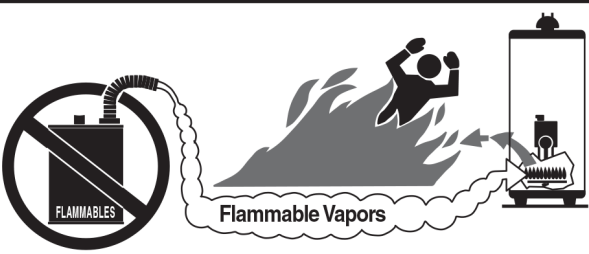

⚠ Vapors from flammable liquids will explode and catch fire causing death or severe burns.
Do not use or store flammable products such as gasoline, solvents or adhesives in the same room or area near the water heater.

Keep flammable products:

1. far away from heater,
2. in approved containers,
3. tightly closed and
4. out of children's reach.

Installation:
Do not install water heater where flammable products will be stored or used unless the main burner and pilot flames

Water heater has a main burner and pilot flame.
The pilot flame:

1. which can come on at any time and
2. will ignite flammable vapors.

Vapors:

1. cannot be seen,
2. are heavier than air,
3. go a long way on the floor and
4. can be carried from other rooms to the pilot flame by air currents.

are at least 18" above the floor. This will reduce, but not eliminate, the risk of vapors being ignited by the main burner or pilot flame.

Read and follow water heater warnings and instructions. If owners manual is missing, contact the retailer or manufacturer.

⚠ DANGER

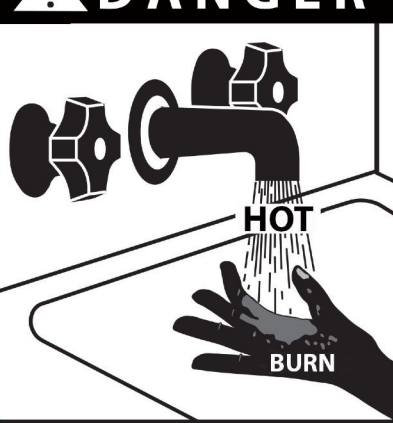

Water temperature over 125°F can cause severe burns instantly or death from scalds. Children, disabled and elderly are at highest risk of being scalded. See instruction manual before setting temperature at water heater. Feel water before bathing or showering. Temperature limiting valves are available, see manual.

WARNING

The hydronic supply and return connections of these products are for installation in closed loop systems ONLY! Use of this product in any manner other than described in this manual may result in premature product failure, substantial property damage, severe personal injury, or death. Damage or failure of this product (or the system in which it is installed) due to unauthorized use **IS NOT COVERED BY WARRANTY.**

NOTICE

IMPORTANT

In accordance with Section 325 (f) (3) of the Energy Policy and Conservation Act, HTP has provided this boiler with multiple features designed to save energy by reducing the boiler water temperature as heating load decreases.

These features include:

- **A modulating combustion system that adjusts firing rate based on heat demand.**
- **Adjustment of boiler set point based on inferred heat load as determined by an outdoor sensor. The outdoor sensor is supplied by HTP with this boiler.**
- **This boiler does not include a standing pilot.**
- **This boiler is designed and shipped to assure the highest efficiency operation possible. Such high efficiency is achieved by limiting heating circuit water temperature to 140°F when there is no anticipated heat load, based upon the outdoor sensor and the Outdoor Reset Curve (sensor response curve) in the boiler software.**
- **This feature may be over-ridden as described below in specific installations:**
- **The boiler control is equipped with an outdoor sensor override for use with building management systems or in cascaded systems (for systems with total input of 300,000 BTU/hr or greater).**

See statement below for an important notice on the use of the override.

IMPORTANT

In accordance with Section 325 (f) (3) of the Energy Policy and Conservation Act, this boiler is equipped with a feature that saves energy by reducing the boiler water temperature as the heating load decreases. This feature is equipped with an override which is provided primarily to permit the use of an external energy management system that serves the same function. THIS OVERRIDE MUST NOT BE USED UNLESS AT LEAST ONE OF THE FOLLOWING CONDITIONS IS TRUE:

- **An external energy management system is installed that reduces the boiler water temperature as the heating load decreases.**
- **This boiler is not used for space heating.**
- **This boiler is part of a modular or multiple boiler system having a total input of 300,000 BTU/hr or greater.**
- **This boiler is equipped with a tankless coil.**

NOTICE

The CSD-1 ASME Code, Section CW-400 requires that hot water heating and supply boilers have a) a UL 353 temperature control device, b) at least one (1) temperature-actuated control to shut off the fuel supply when system water reaches a preset operating temperature, c) a high temperature limit control that prevents the water temperature from exceeding the maximum allowable temperature by causing a safety shutdown and lockout, and d) its own sensing element and operating switch.

The temperature control system integrated into the 926 control provided with this heating appliance complies with the requirements of CSD-1 Section CW-400 as a temperature operation control. The control monitors the temperature difference between the inlet and the outlet sensor, which is affected by boiler water flow. If this temperature difference exceeds 55°F (typically because of low water flow or very low heat load), the control will reduce the maximum fan speed. If the temperature difference exceeds 60°F, the control will effectively sense there is little or no water flow or heat load and shut the boiler down. The controller will restart automatically once the temperature difference has dropped below 55°F and the minimum off time (anti-cycle time) has expired. In addition, if the control senses that the outlet water temperature has reached 210°F, the boiler is put into a hard lockout and requires manual reset to restart.

Table of Contents

Part 1 - General Safety Information	5
A. Operation and Installation Warnings	5
B. Improper Combustion	6
C. Gas	6
D. When Servicing the Boiler	6
E. Boiler System	7
F. Water Chemistry Requirements	7
G. Freeze Protection	7
H. High Elevation Installations	7
Part 2 - Before You Start	8
A. What's in the Box	8
B. Optional Equipment	8
Part 3 - Prepare the Boiler Installation	9
A. Locating the Boiler	9
B. Leveling	9
C. Clearances for Service Access	10
D. Residential Garage and Closet Installations	10
E. Exhaust Vent and Intake Pipe	10
1. Direct Vent of Exhaust and Intake	11
2. Power Venting, Indoor Combustion Air in Confined or Unconfined Space	11
F. Carbon Monoxide Detectors	11
G. Prevent Combustion Air Contamination	11
H. Removing a Boiler from a Common Vent System	12
I. Technical Specifications	13
J. Wall-Mounting (Wall Mount Models Only)	17
Part 4 - Water Piping	18
A. General Plumbing Guidelines	18
B. Backflow Preventer	18
C. Expansion Tank	18
D. Piping the Boiler	18
E. Applications	19
F. Circulator Sizing	29
G. Pressure Relief Valve	29
H. Built-In Low Water Cut-Off (LWCO)	30
I. Optional External UL353 Manual Reset Low Water Cut-Off (LWCO) Interface Kit	30
Part 5 - Venting	31
A. General	31
B. Approved Materials for Exhaust Vent and Intake Pipe	32

C. Additional Requirements for Installation in Canada 32
 D. Exhaust Vent and Intake Pipe Location 33
 E. Exhaust Vent and Intake Pipe Sizing 34
 F. Tightening Boiler Collar to Exhaust Vent and Intake Pipe 34
 G. Exhaust Vent and Intake Pipe Installation 34
 H. Applications 35
 1. Direct Vent Installation of Exhaust and Intake 35
 2. Venting Through an Existing System 35
 3. Power Venting, Indoor Combustion Air in Confined or Unconfined 38
 Space 39
Part 6 - Installing the Condensate Drain 40
Part 7 - Connecting Electrical Service 41
 A. Wiring 41
 B. Dip Switches 41
 C. Wiring a Cascaded System 42
Part 8 - Gas Connections 46
 A. Gas Pipe Sizing Tables 46
 1. Gas Pipe Sizing 46
 2. Natural Gas Pipe Sizing 46
 3. LP (Liquid Propane) Gas Pipe Sizing 47
 B. Gas Connection Requirements 47
 C. Additional Precaution for Excess Flow Valve (EFV) 47
 D. Checking Gas Pressure at the Boiler for Proper Operation 47
 E. Setting and Verifying the Combustion Setting 47
Part 9 - Controls 48
 A. Control and Display Overviews 48
 B. Start-Up Sequence 49
 C. Changing the CH Set-Point 49
 D. Changing the Time 49
 E. Status Display 50
 F. Installer Mode 51
 G. Setting Up a Cascaded System 54
 H. Outdoor Temperature Mode (Optional) 54
 I. 0-10 Volt Input 54
 J. Step Modulation 55
Part 10 - Troubleshooting 56
 A. Error Code 56
 B. Error Tree Analysis 59
 1. Flame Detection 59
 2. Air Pressure Switch / Burner Overheat Limit / Condensate Block Switch 59
 3. Storage / Operating Temperature / CH Overheat / Exhaust Sensors 59
 C. Suggested Corrective Actions 60
Part 11 - Start-Up 61
 A. Check / Control Water Chemistry 61
 B. Check for Gas Leaks 62
 C. Freeze Protection (When Used) 62
 D. Fill and Test Water System 62
 E. Purge Air from Water System 63
 F. Check Thermostat Circuit(s) 63
 G. Condensate Removal 63
Part 12 - Installation Checklist 64
Part 13 - Maintenance 65
Part 14 - Moving Adapters from Left to Right (Floor Models) 69
Part 15 - Replacement Parts 69
 Limited Warranty for UFT Boilers 79
 Notes 81
 Customer Installation Record Form 84

combustible door.) This boiler has been approved for closet installation and installation on combustible flooring. Do not install directly on carpeting. Install the boiler in a location where relief valve discharge or a leak will not result in damage to the surrounding area. The appliance is rated Category IV (pressurized vent, likely to form condensate in the vent) and requires a special vent system designed for pressurized venting. Use only Category IV vent systems.

WARNING

Installer - Read all instructions in this manual before installing. Perform steps in the given order.

User - This manual is for use only by a qualified heating installer / service technician. Have this boiler serviced / inspected annually by a qualified service technician.

FAILURE TO ADHERE TO THE GUIDELINES ON THIS PAGE CAN RESULT IN SUBSTANTIAL PROPERTY DAMAGE, SEVERE PERSONAL INJURY, OR DEATH.

NOTE: Obey all local codes. Obtain all applicable permits before installing the boiler.

NOTE: Install all system components and piping in such a manner that does not reduce the performance of any fire rated assembly.

A. Operation and Installation Warnings
 To avoid serious injury or death, read, understand, and follow all of the precautions listed here.

DANGER

Vapors from flammable liquids will explode and can cause a fire, resulting in personal injury or death. The boiler has a burner that can come on at any time and ignite vapors. DO NOT use or store flammable liquids around the boiler.

Improper venting can cause a build-up of carbon monoxide. Breathing carbon monoxide can result in brain damage or death. DO NOT operate the boiler unless it is properly vented to the outside and has an adequate fresh air supply for safe operation. Inspect the exterior exhaust gas outlet port and fresh air inlet port on a regular basis to ensure they are functioning properly.

A concentration of carbon monoxide as small as .04% (400 parts per million) in the air can be fatal. When making high fire or low fire adjustments, CO levels must be monitored using a calibrated combustion analyzer such that a CO level of no more than 150 ppm is exceeded at any time during operation.

Adjusting the "low fire offset" or the "main flow restrictor" in small increments can result in a significant increase in CO concentration. To avoid serious injury or death, DO NOT make any adjustments to the gas valve without monitoring the exhaust gases with a fully functional and calibrated combustion analyzer.

Failure to follow these instructions will result in property damage, severe personal injury, or death.

This boiler must be installed by a licensed plumber, licensed gas fitter, and/or professional service technician. Improper installation and/or operation can cause a potentially hazardous situation, which, if not avoided, could result in serious injury or death, and will void the warranty.

The manufacturer cannot anticipate every circumstance that might involve a potential hazard. Each installation has its own specialized characteristics, requirements, and possible hazards. Therefore, all possible incidents are not included in these warnings. Proper and safe installation, operation, and service are the responsibility of the professional service technician.

Do not power up the unit unless the gas and water supply valves are fully opened. Make sure the fresh air intake port and exhaust gas port are open and functional.

Part 1 - General Safety Information

This boiler is approved for indoor installations only and is not intended for use as a pool heater. Clearance to combustible materials: 0" top, bottom, sides, and back. Boiler must have room for service: 24" front, 18" top, 12" bottom, and 0" back are minimum recommended service clearances. Minimum recommended side clearances depend on model and installation options. (A combustible door or removable panel is acceptable front clearance. A 3" minimum clearance must be provided from the boiler front cover to the removable panel or

⚠ WARNING

Proper care of the boiler is the user's responsibility. Ensure the user carefully reads and understands the User's Information Manual before operating and maintaining the boiler.

Make sure the user knows the location of the gas shut-off valve and how to operate it. Immediately close the gas shut-off valve if the boiler is subjected to fire, overheating, flood, physical damage, or any other damaging condition that might affect the operation of the unit. Have the boiler checked by a qualified technician before resuming operation.

No one but a professional service technician should attempt to install, service, or repair this boiler. There are no serviceable parts which can be changed by the user / owner. User / Owner: Contact the original professional service technician if the boiler needs repair or maintenance. If the original technician is unavailable, ask your gas supplier for a list of qualified service providers.

Keep the area around the boiler clean and free of all materials that can burn. DO NOT store or place gasoline, oils, spray paint, or other flammable products near the boiler.

DO NOT use spray paint, hair spray, or any other flammable spray near the boiler or near the exterior fresh air intake port. DO NOT place any items in or around the exterior exhaust gas outlet port and/or fresh air inlet port that could restrict or block the flow in or out of the vent system.

DO NOT store or place newspapers, laundry, or other combustible items near the boiler or the exterior exhaust gas outlet and/or fresh air inlet port.

The owner should inspect the system monthly for damage, water stains, signs of rust, corrosion, and exhaust vent and air intake blockage. If inspection of the unit shows signs of damage, the boiler should be shut off until the problem is repaired by a qualified technician.

After installation, all boiler safety devices should be tested.

This boiler is certified for indoor installations only. The boiler consists of gas ignition system components which must be protected from water (dripping, spraying, etc.) during operation and service. Carefully consider installation location and the placement of critical components (circulators, condensate neutralizers, etc.) before installing the boiler.

DO NOT allow children to operate this unit. DO NOT use this unit if it does not appear to be operating correctly. A qualified technician should service and inspect the boiler annually.

NOTICE

This boiler is equipped with a three prong plug. It should only be plugged directly into a properly grounded three prong receptacle. DO NOT remove the ground plug from the plug.

Any claims for damage or shortage in shipment must be filed immediately against the transportation company by the consignee.

This boiler provides a overheat shutdown limit. In the event the boiler water temperature exceeds the set point of the control limit, the cutoff will trip and the boiler will shut down. Certain local codes require additional temperature limits. In addition, certain types of systems may operate at temperatures below the minimum set point of the limit provided with the boiler. Contact the manufacturer for additional overheat controls.

NOTE: When inquiring about service or troubleshooting, reference the model and serial numbers from the boiler rating label.

⚠ WARNING

DO NOT USE THIS BOILER IF ANY PART HAS BEEN SUBMERGED IN WATER. Immediately call a qualified service technician. The boiler **MUST BE** replaced if it has been submerged. Attempting to operate a boiler that has been submerged could create numerous harmful conditions, such as a potential gas leakage causing a fire and/or explosion, or the release of mold, bacteria, or other harmful particulates into the air. Operating a previously submerged boiler could result in property damage, severe personal injury, or death. **NOTE:** Boiler damage due to flood or submersion is considered an Act of God, and IS NOT covered under product warranty.

NOTE: If the boiler is exposed to the following, do not operate. Immediately call a qualified service technician.

1. Fire
2. Damage
3. Water

Failure to follow this information could result in property damage, severe personal injury, or death.

DO NOT alter or modify the boiler or boiler controls. Altering any HTP boiler with parts not manufactured by HTP **WILL INSTANTLY VOID** the boiler warranty and could result in property damage, personal injury, or death.

CAUTION

Do not use this boiler for anything other than its intended purpose (as described in this manual). Doing so could result in property damage and **WILL VOID** product warranty.

Due to the low water content of the boiler, improper sizing of the boiler with regard to heating system load will result in excessive cycling and accelerated component failure. HTP **DOES NOT** warrant failures caused by improperly sized boiler applications. **DO NOT** oversize the boiler to the system. Modular boiler installations greatly reduce the likelihood of boiler oversizing.

B. Improper Combustion

⚠ WARNING

Do not obstruct the flow of combustion and ventilating air. Adequate air is necessary for safe operation. Failure to keep the exhaust vent and combustion air intake clear of ice, snow, or other debris could result in property damage, serious personal injury, or death.

C. Gas

Should overheating or gas supply fail to shut off, turn off the manual gas control valve to the boiler.

D. When Servicing the Boiler

⚠ WARNING

Be sure to disconnect electrical power before opening boiler cabinet or performing service. Label all wires while performing service to ensure proper re-wiring of the boiler. Wiring errors can cause improper or dangerous operation. Failure to do so could result in an electrical shock, improper boiler operation, property damage, serious personal injury, or death.

- To avoid electric shock, disconnect electrical supply before performing maintenance.
- To avoid severe burns, allow boiler and associated equipment to cool before servicing.
- Do not use petroleum-based cleaning or sealing compounds in a boiler system. Gaskets and seals in the system may be damaged. This can result in substantial property damage.
- Do not use "homemade cures" or "patent medicines".

Damage to the boiler, substantial property damage, and/or serious personal injury may result.

- Always verify proper operation after servicing the boiler.

NOTE: When inquiring about service or troubleshooting, reference the model and serial numbers from the boiler rating label.

E. Boiler System

- Thoroughly flush the system (without the boiler connected) to remove sediment. The high efficiency heat exchanger can be damaged by build-up or corrosion due to sediment. The manufacturer recommends a suction strainer in all systems.
- Do not use petroleum-based cleaning or sealing compounds in a boiler system. Gaskets and seals in the system may be damaged. This can result in substantial property damage.
- Do not use “homemade cures” or “patent medicines”. Damage to the boiler, substantial property damage, and/or serious personal injury may result.

Continual fresh make-up water will reduce boiler life. Mineral buildup in the heat exchanger reduces heat transfer, overheats the stainless steel heat exchanger, and causes failure. Addition of oxygen from make-up water can cause internal corrosion in system components. Leaks in the boiler or piping must be repaired at once.

F. Water Chemistry Requirements

CAUTION
Chemical imbalance of the water supply may affect efficiency and cause severe damage to the appliance and associated equipment. Water quality must be professionally analyzed to determine whether it is necessary to treat the water. Various solutions are available to adjust water quality. Adverse water quality will affect the reliability of the system. In addition, operating temperatures above 135°F will accelerate the build-up of lime scale and possibly shorten appliance service life. Failure of an appliance due to lime scale build-up, low pH, or other chemical imbalance IS NOT covered by the warranty.

The water must be potable, free of corrosive chemicals, sand, dirt, and other contaminants. It is up to the installer to ensure the water does not contain corrosive chemicals or elements that can damage the heat exchanger. Potable water is defined as drinkable water supplied from utility or well water in compliance with EPA secondary maximum contaminant levels (40 CFR Part 143.3). If the water contains contaminants higher than outlined by the EPA, water treatment is recommended and additional, more frequent maintenance may be required. See Table 1.

If you suspect that your water is contaminated in any way, discontinue use of the appliance and contact an authorized technician or licensed professional.

Contaminant	Maximum Allowable Level
Total Hardness (Above 140°F water temperature)	120 mg/l (7 grains/gallon)
Aluminum	0.05 to 0.2 mg/l or PPM
Chloride	100 mg/l or PPM
Copper	1 mg/l or PPM
Iron	0.3 mg/l or PPM
Manganese	0.05 mg/l or PPM
pH	6.5 - 8.5
Sulfate	205 mg/l or PPM
Total Dissolved Solids (TDS)	500 mg/l or PPM
Zinc	5 mg/l or PPM
Dissolved Carbon Dioxide (CO2)	15 mg/l or PPM

Table 1 - Water Quality Specifications

G. Freeze Protection

CAUTION
Consider piping and installation when determining boiler location. Damages resulting from incorrect installation or from use of products not approved by the manufacturer ARE NOT covered by warranty.
WARNING
NEVER use any toxic chemical, including automotive, standard glycol antifreeze, or ethylene glycol made for hydronic (non-potable) systems. These chemicals can attack gaskets and seals in water systems, are poisonous if consumed, and can cause personal injury or death.

The boiler control is equipped with freeze protection that activates based on internal water temperature. See the table below for details on freeze protection operation.

NOTE: Freeze protection will not be active if the boiler loses power.

	Freeze Protection Operation	Range
System Freeze Protection (Activates Based on Internal Water Temperature)	Stage 1 - If control detects water temperature of 46°F (8°C) and below, it turns the internal and external pumps On for 600 seconds and Off for 30 seconds. This cycle repeats until the control detects inlet water temperature of 50°F (10°C) and above.	ON or OFF (Default: ON) NOTE: If using boiler for Snow Melt applications, turn Freeze Protection OFF.
	Stage 2 - If control detects water temperature of 41°F (5°C) and below, it turns the burner on to meet a target temperature of 104°F (40°C). The burner and internal and external pumps will continuously during this stage until the control detects inlet water temperature of 104°F (40°C) and above.	
	Stage 3 - If control detects water temperature of 34°F (1°C) and below, Er: 85 will appear on the display.	

Table 2 - Freeze Protection Detail

H. High Elevation Installations

WARNING
Natural gas at high elevation might contain less heating value than typical 1,000 BTU/cu ft and therefore can cause improper air / gas mix leading to improper combustion. For natural gas installations above 3,000 ft, call your gas provider to determine the heating value of the supplied natural gas.

Part 2 - Before You Start

Open the shipping crate of the boiler.

NOTICE

UNCRATING THE BOILER - Any claims for damage or shortage in shipment must be filed immediately against the transportation company by the consignee.

A. What's in the Box

Components included with the boiler:











Item	Description	Quantity
Universal Fire Tube Boiler		One (1) Floor or Wall Mounted Boiler
User and Installation Manuals		One (1) each
Condensate Hose (Wall Mount Only) (Part # - 7855P-089)		One (1)
Anchors and Wall Mounting Bracket (Wall Mount Only) (7850P-084)		One (1) Kit
Outdoor Sensor with Screws and Anchors (7855P-084)		One (1)
Spare Parts Kit (Gaskets and O-Rings) (7855P-383)		One (1)
LP Conversion Kit (175/199 Models Only) (7855P-452)		One (1)
Vent Screens (3") (7850P-085)		Two (2) screens
30 PSI Pressure Relief Valve (7855P-077)		One (1)
1 1/4" X 1 1/4" X 3/4" Tee (steel) (7855P-313), 3/4" Elbow (steel) (7350P-084)		One (1) Each
3" CPVC (7855P-101)		One (1)

Table 3 - Included with the Boiler

B. Optional Equipment

Optional equipment available from HTP (and Part #):



Optional Parts		
Cascade Communication Cable (7850P-093)		One (1)
System Sensor (7250P-324)		1
Indirect Tank Sensor (7250P-325)		1

Table 4 - Optional Equipment

Other Optional Equipment

Below is a list of other optional equipment available from HTP. These additional options may be purchased through your HTP distributor:

- 2" PVC Concentric Vent Kit (Part # KGAVT0501CVT)
- 3" PVC Concentric Vent Kit (Part # KGAVT0601CVT)
- 2" Stainless Steel Outside Termination Vent Kit (Part # V500)
- 3" Stainless Steel Outside Termination Vent Kit (Part # V1000)
- 4" Stainless Steel Outside Termination Vent Kit (Part # V2000)
- 6" Stainless Steel Outside Termination Vent Kit (Part # V3000)
- 3" Polypro Vent Kit (Part # 8400P-001)
- 3" Polypro Pipe (33' length Part # 8400P-002, 49.5' length Part # 8400P-003)
- Condensate Neutralizer (Part # 7450P-212)
- Condensate Removal Pump (Part # 554200)
- 2" Mesh Vent Screens (Part # 7850P-088)
- UL353 Low Water Cut-Off Kit (Part # 7855P-315)
- Conversion Kit

NOTE: When using an optional system sensor, pipe insulation must be wrapped around it to improve temperature measurement accuracy and increase overall system efficiency.

Part 3 - Prepare the Boiler Installation

Remove all sides of the shipping crate to allow the boiler to be moved into its installation location.

CAUTION
COLD WEATHER HANDLING - If the boiler has been stored in a very cold location (BELOW 0°F) before installation, handle with care until the components come to room temperature. Failure to do so could result in damage to the boiler.
Carefully consider installation when determining boiler location. Please read the entire manual before attempting installation. Failure to properly take factors such as venting, piping, condensate removal, and wiring into account before installation could result in wasted time, money, and possible property damage and personal injury.

A. Locating the Boiler

WARNING
This boiler is certified for indoor use only. DO NOT INSTALL OUTDOORS. Outdoor installations ARE NOT covered by warranty. Failure to install the boiler indoors could result in property damage, severe personal injury, or death.
Incorrect ambient conditions can lead to damage to the heating system and put safe operation at risk. Ensure that the installation location adheres to the information included in this manual. Failure to do so could result in property damage, serious personal injury, or death. Failure of boiler or components due to incorrect operating conditions IS NOT covered by product warranty.
This boiler must be installed upright in the vertical position as described in this manual. DO NOT attempt to install this boiler in any other orientation. Doing so will result in improper boiler operation and property damage, and could result in serious personal injury or death.

1. Installation Area (Mechanical Room) Operating Conditions

- Ensure ambient temperatures are higher than 32°F / 0°C and lower than 104°F / 40°C
- Prevent the air from becoming contaminated by the products, places, and conditions listed in this manual
- Avoid continuously high levels of humidity
- Never close existing ventilation openings
- Ensure a minimum 1" clearance around hot water and exhaust vent pipes

- **NOTE:** To prevent condensing in the fan, it is recommended to avoid prolonged exposure to temperatures below 45°F

WARNING
This boiler has a condensate disposal system that may freeze if exposed to sustained temperatures below 32°F. Precautions should be taken to protect the condensate trap and drain lines from sustained freezing conditions. Failure to take precautions could result in property damage, severe personal injury, or death.
CAUTION
The service life of the boiler's exposed metallic surfaces, such as the casing, as well as internal surfaces, such as the heat exchanger, are directly influenced by proximity to damp and salty marine environments. In such areas higher concentration levels of chlorides from sea spray coupled with relative humidity can lead to degradation of boiler components. In these environments, boilers must not be installed using direct vent systems which draw outdoor air for combustion. Such boilers must be installed using room air for combustion. Indoor air will have a much lower relative humidity, and hence potential corrosion will be minimized.

2. Check for nearby connections to:

- System water piping
- Venting connections
- Gas supply piping
- Electrical power
- Condensate drain

3. Check area around boiler. Remove any combustible materials, gasoline, and other flammable liquids.

WARNING
Failure to keep the boiler area clear and free of combustible materials, liquids, and vapors can result in substantial property damage, severe personal injury, or death.

4. Gas control system components must be protected from dripping water during operation and service.

5. If the boiler is to replace an existing boiler, check for and correct any existing system problems, such as:

- System leaks
- Location that could cause the system and boiler to freeze and leak
- Incorrectly sized expansion tank

6. Clean and flush system when reinstalling a boiler.

NOTE: When installing in a zero clearance location, it may not be possible to read or view some product labeling. It is recommended to make note of the boiler model and serial number.

CAUTION
Do not introduce toxic chemicals, such as antifreeze or boiler treatments, into any piping meant for potable water purposes.

B. Leveling

CAUTION
In order for the condensate to properly flow out of the collection system, the area where you locate the boiler must be level. Location must also fully support the weight of the filled boiler.

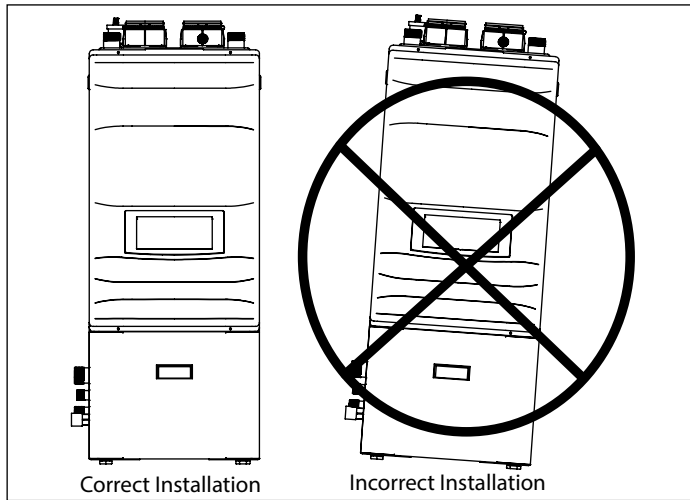

Figure 1 - Leveled Boiler (Floor Model)

C. Clearances for Service Access

See Table 5 for recommended service clearances. If these minimum clearances are not provided, it may not be possible to service the boiler without removing it from the space.

WARNING

The space must be provided with combustion / ventilation air openings correctly sized for all other appliances located in the same space as the boiler. The boiler cover must be securely fastened to prevent the boiler from drawing air from the boiler room. This is particularly important if the boiler is in a room with other appliances. Failure to comply with the above warnings could result in substantial property damage, severe personal injury, or death.

Minimum Clearances	
Installation Clearances from Non-Combustibles / Combustibles	Recommended Service and Proper Operation Clearances
Top	18" (45.7 cm)
Back	0" (0 cm)
Bottom (Wall Mount Model)	12" (30.45 cm)
Bottom (Floor Model)	0" (0 cm)
Front	24" (60.9 cm)
Right or Left Side (Wall Mount Model)	3" (7.6 cm)
*Side without Adapters (Floor Model)	
*Adapter Side (Floor Model)	24" (60.96 cm)

Table 5 - Minimum Installation and Service Clearances - *NOTE: The piping configuration of the Floor Model can be changed from the left to the right side of the boiler.

NOTE: For closet installations, a combustible door or removable panel is acceptable front clearance. A 3" minimum clearance must be provided from the appliance front cover to the removable panel or combustible door.

NOTE: If you do not provide the minimum clearances shown in Table 5 it might not be possible to service the boiler without removing it from the space.

MINIMUM CLEARANCES FROM COMBUSTIBLE MATERIALS

- Hot water pipes - at least 1" from combustible materials
- Exhaust vent pipe - at least 1" from combustible materials

CAUTION

All boilers eventually leak. Locate the boiler where any leakage from the relief valve, related piping, tank, or connections will not result in damage to surrounding areas or lower floors of the building. Any boiler should be installed in such a manner that if it should leak the resulting flow of water will not cause damage to the area in which it is installed. If the boiler is installed in a location where a leak could cause damage, it is required to provide containment measures. Such measures include but are not limited to: a properly sized drain pan installed beneath the boiler and piped to an open drain line, or installing the boiler on a concrete floor pitched to a free flowing drain. Failure to provide containment measures is the sole responsibility of the owner and/or installer. Leakage damages ARE NOT covered by warranty.

In addition, water leak detection devices and automatic water shutoff valves are readily available at plumbing supply houses. IT IS HIGHLY RECOMMENDED BY THE MANUFACTURER TO INSTALL WATER LEAK DETECTION DEVICES AND AUTOMATIC SHUTOFF VALVES IN ANY BOILER INSTALLATION WHERE A LEAKAGE OF WATER COULD RESULT IN PROPERTY DAMAGES.

Always take future maintenance into consideration when locating the boiler. If the boiler is located in an installation location with limited clearances, it may be necessary to remove the boiler from the space to perform maintenance. Failure to consider maintenance when determining installation location could result in property damage.

D. Residential Garage and Closet Installations

CAUTION

Check with your local Authority Having Jurisdiction for requirements when installing the boiler in a garage or closet. Please read the entire manual before attempting installation. Failure to properly take factors such as venting, piping, condensate removal, and wiring into account before installation could result in wasted time, money, and possible property damage and personal injury.

Precautions

If the boiler is located in a residential garage, per ANSI Z223.1:

- Mount the bottom of the boiler a minimum of 18" above the floor of the garage to ensure the burner and ignition devices are well off the floor.
- Locate or protect the boiler so it cannot be damaged by a moving vehicle.



WARNING

The space must be provided with correctly sized combustion/ventilation air openings for all other appliances located in the space with the boiler. For power venting installations using room air for combustion, refer to the venting section, this manual, for descriptions of confined and unconfined spaces. Do not install the boiler in an attic. Failure to comply with these warnings could result in substantial property damage, severe personal injury, or death.

E. Exhaust Vent and Intake Pipe

The boiler is rated Category IV (pressurized vent, likely to form condensate in the vent) and requires a special vent system designed for pressurized venting.

NOTE: The venting options described here (and further detailed in the Venting section, this manual) are the lone venting options approved for this boiler. Failure to vent the boiler in accordance with the provided venting instructions will void the warranty.

 DANGER
Failure to vent the boiler properly will result in serious personal injury or death.
 WARNING
Do not attempt to vent this boiler by any means other than those described in this manual. Doing so will void the warranty and may result in severe personal injury or death.
Vents must be properly supported. Boiler exhaust and intake connections are not designed to carry heavy weight. Vent support brackets must be within 1' of the boiler and the balance at 4' intervals. Boiler must be readily accessible for visual inspection for first 3' from the boiler. Failure to properly support vents could result in property damage, severe personal injury, or death.
The exhaust discharged by this boiler may be very hot. Avoid touching or other direct contact with the exhaust gases of the vent termination assembly. Doing so could result in severe personal injury or death.

1. Direct Vent of Exhaust and Intake

If installing a direct vent option, combustion air must be drawn from the outdoors directly into the boiler intake and exhaust must terminate outdoors. There are three basic direct vent options detailed in this manual: 1. Side Wall Venting, 2. Roof Venting, and 3. Unbalanced Venting.

Be sure to locate the boiler such that the exhaust vent and intake piping can be routed through the building and properly terminated. Different vent terminals can be used to simplify and eliminate multiple penetrations in the building structure (see Optional Equipment in Venting Section). The exhaust vent and intake piping lengths, routing, and termination methods must all comply with the methods and limits given in the Venting Section, this manual.

When installing a combustion air intake from outdoors, care must be taken to utilize uncontaminated combustion air. **To prevent combustion air contamination, see Table 6.**

2. Power Venting, Indoor Combustion Air in Confined or Unconfined Space

This boiler requires fresh, uncontaminated air for safe operation and must be installed in a mechanical room where there is adequate combustion and ventilating air. **NOTE: To prevent combustion air contamination, see Table 6.**

Combustion air from the indoor space can be used if the space has adequate area or when air is provided through a duct or louver to supply sufficient combustion air based on the boiler input. Never obstruct the supply of combustion air to the boiler. If the boiler is installed in areas where indoor air is contaminated (see Table 6) it is imperative that the boiler be installed as direct vent so that all combustion air is taken directly from the outdoors into the boiler intake connection.

Unconfined space is space with volume greater than 50 cubic feet per 1,000 BTU/hr (4.8 cubic meters per kW) of the total input rating of all fuel-burning appliances installed in that space. Rooms connected directly to this space through openings not furnished with doors are considered part of the space. See Venting Section for details.

Confined space is space with volume less than 50 cubic feet per 1,000 BTU/hr (4.8 cubic meters per kW) of the total input rating of all fuel-burning appliances installed in that space. Rooms connected directly to this space through openings not furnished with doors are considered part of the space.

When drawing combustion air from inside a conventionally constructed building to a confined space, such space should be provided with two permanent openings: one located 6" (15cm) below the space ceiling, the other 6" (15cm) above the space floor. Each opening should have a free area of one square inch per 1,000 BTU/hr (22cm²/kW) of the total input of all appliances in the space,

but not less than 100 square inches (645cm²).

If the confined space is within a building of tight construction, air for combustion must be obtained from the outdoors as outlined in the Venting section of this manual.

CAUTION
When drawing combustion air from the outside into the mechanical room, care must be taken to provide adequate freeze protection.
 WARNING
Failure to provide an adequate supply of fresh combustion air can cause poisonous flue gases to enter the living space, resulting in severe personal injury or death. To prevent combustion air contamination, see Table 6.

F. Carbon Monoxide Detectors In the Commonwealth of Massachusetts and As Required by State and Local Codes:

Installation of Carbon Monoxide Detectors: At the time of installation or replacement of the vented gas fueled appliance, the installing plumber or gas fitter shall observe that a hard wired carbon monoxide detector with an alarm and battery back-up is installed on the floor level where the gas appliance is installed, unless the appliance is located in a detached, uninhabitable structure separate from the dwelling, building, or structure used in whole or in part for residential purposes.

In addition, the installing plumber or gas fitter shall observe that a hard wired carbon monoxide detector with an alarm and battery back-up is installed on each additional level of the dwelling, building, or structure served by the vented gas appliance. It shall be the responsibility of the property owner to secure the service of qualified licensed professionals for the installation of hard wired carbon monoxide detectors.

a. In the event that the vented gas fueled appliance is installed in a crawl space or attic, the hard wired carbon monoxide detector with alarm and battery back-up shall be installed on the next adjacent floor level.

b. In the event that these requirements cannot be met at the time of completion of installation, the owner shall have a period of thirty (30) days to comply with the above requirements; provided, however, that during said thirty (30) day period, a battery operated carbon monoxide detector with an alarm shall be installed.

 WARNING
Do not attempt to vent this boiler by any means other than those described in this manual. Doing so will void the warranty and may result in severe personal injury or death.

Approved Carbon Monoxide Detectors: Each carbon monoxide detector as required in accordance with the above provisions shall comply with NFPA 70 and be ANSI/UL 2034 listed and IAS certified.

G. Prevent Combustion Air Contamination

Install intake air piping for the boiler as described in the Venting Section, this manual. Do not terminate exhaust in locations that can allow contamination of intake air.

 WARNING
Ensure that the intake air will not contain any of the contaminants in Table 6. Contaminated air will damage the boiler, resulting in possible substantial property damage, severe personal injury, or death. For example, do not pipe intake air near a swimming pool or laundry facilities. These areas always contain contaminants.

Products to Avoid	Areas Likely to Have Contaminants
Spray cans containing fluorocarbons	Dry cleaning / laundry areas and establishments
Permanent wave solutions	Swimming pools
Chlorinated waxes / cleaners	Metal fabrication plants
Chlorine-based swimming pool chemicals	Beauty shops
Calcium chloride used for thawing	Refrigeration repair shops
Sodium chloride used for water softening	Photo processing plants
Refrigerant leaks	Auto body shops
Paint or varnish removers	Plastic manufacturing plants
Hydrochloric or Muriatic acid	Furniture refinishing areas and establishments
Cements and glues	New building construction
Antistatic fabric softeners used in clothes dryers	Remodeling areas
Chlorine-type bleaches, laundry detergents, and cleaning solvents	Garages and workshops
Adhesives used to fasten building products	

Table 6 - Products and Areas Likely to Have Contaminants

NOTE: DAMAGE TO THE BOILER CAUSED BY EXPOSURE TO CORROSIVE VAPORS IS NOT COVERED BY WARRANTY. (Refer to the limited warranty for complete terms and conditions.)

H. Removing a Boiler from a Common Vent System

DANGER

Do not install the boiler into a common vent with any other appliance. This will cause flue gas spillage or appliance malfunction, resulting in possible substantial property damage, severe personal injury, or death.

WARNING

Failure to follow all instructions can result in flue gas spillage and carbon monoxide emissions, causing severe personal injury or death.

When removing an existing boiler, follow the steps below.

1. Seal any unused openings in the common venting system.
2. Visually inspect the venting system for proper size and horizontal pitch to determine if there is blockage, leakage, corrosion, or other deficiencies that could cause an unsafe condition.
3. If practical, close all building doors, windows, and doors between the space in which the boiler remains connected to the common venting system and other spaces in the building. Turn on clothes dryers and any appliances not connected to the common venting system. Turn on any exhaust fans, such as range hoods and bathroom exhausts, at maximum speed. Do not operate a summer exhaust fan. Close all fireplace dampers.
4. Place in operation the appliance being inspected. Follow the lighting instructions. Adjust the thermostat so the appliance will operate continuously.
5. Test for spillage at the draft hood relief opening after 5 minutes of main burner operation. Use the flame of a match or candle or smoke from a cigarette.
6. After it has been determined that each appliance remaining connected to the common venting system properly vents when tested as outlined, return doors, windows, exhaust fans, fireplace dampers, and any other gas burning appliances to their previous condition of use.
7. Any improper operation of the common venting system should be corrected to conform to the National Fuel Gas Code, ANSI Z223.1. When resizing any portion of the common venting system, the system should approach the minimum size as determined using the appropriate tables in Appendix G of ANSI Z223.1.

WARNING

Breathing Hazard - Carbon Monoxide Gas

- Do not operate heater if flood damaged.
- Install vent system in accordance with local codes and manufacturers installation instructions.
- Do not obstruct heater air intake or exhaust. Support all vent piping per manufacturers installation instructions.
- Do not place chemical vapor emitting products near unit.
- According to NFPA 720, carbon monoxide detectors should be installed outside each sleeping area.
- Never operate the heater unless it is vented to the outdoors.
- Analyze the entire vent system to make sure that condensate will not become trapped in a section of vent pipe and therefore reduce the open cross sectional area of the vent.

Breathing carbon monoxide can cause brain damage or death. Always read and understand instruction manual.

LP-304

Figure 2 - CO Warning Label

I. Technical Specifications

Model		80	100	120	140	175	199
Installation		Indoor, Wall Mounted Model or Floor Model, Fully Condensing					
Minimum / Maximum Input (Btu/Hr)		8,000 / 80,000	10,000 / 100,000	12,000 / 120,000	14,000 / 140,000	19,900 / 175,000	19,900 / 199,000
Heating Capacity (MBH)		76	95	114	133	166	189
Flue System		Sealed Combustion Direct Vent, Power Vent					
Vent Run		2" (50 feet), 3" (100 feet), Schedule 40 PVC, CPVC, PP					
Weight (lbs) Wall Mount Model		90		100		110	
Weight (lbs) Floor Model		120		130		140	
Gas Supply Pressure	NG	3.5" to 14" WC					
	LP						
Power Supply	Main Supply	120V 60 Hz, 6A					
	Maximum Power Consumption	160W					
General Operating Conditions		Ambient Temperature Range: 33 – 104°F (0.6 – 40°C) Operating Relative Humidity: Up to 90% at 140°F (40°C) Shipping and Storage Temperature Range: -4 – 176°F (-20 – 80°C) Power Supply and Communication (CN4): 14V DC Product Approvals and Requirements EMC: 89/336/EEC LVD: 73/23/EEC					
Ignition System		Direct Electronic Ignition / Automatic Flame Sensing					
Burner System		Premixed Fuel Modulation / Ceramic Fiber Infrared					
Gas Valve System		Combination Modulating (Current Proportional)					
Internal Pipe Material		Copper					
Wall Mount Model Dimensions		W 17.5" - H 34" - D 15.4"				W 19.7" - H 37" - D 16.8"	
Floor Model Dimensions		W 19" - H 45" - D 17"				W 22" - H 48" - D 18"	
Heat Exchanger Water Capacity		3 Gallons					
Control Panel / Main Controller		P-950EH / NGTB-900C					
Water Pressure		Min 12 - Max 30 PSI					
Connection Sizes	Space Heating Supply / Return	1 1/4" NPT					
	Gas Inlet	3/4" NPT					
Materials	Cabinet (Wall Mount Model)	Painted Cold Rolled Carbon Steel					
	Cabinet (Floor Model)	Galvaneal					
	Heat Exchanger	316L Stainless Steel					
Safety Devices		Optical Flame Sensor, Burner Plate High Limit (392°F), Water Temperature High Limit Sensor (200°F), Freeze Protection (Three Stage Operation - Activates at 46°F – See Freeze Protection in Installer Menu for Details), Exhaust Temperature High Limit Sensor (190°F), Blocked Flue Switch, Condensate Switch, Built-In Low Water Cut-Off Probe					

Table 7 - Technical Specifications

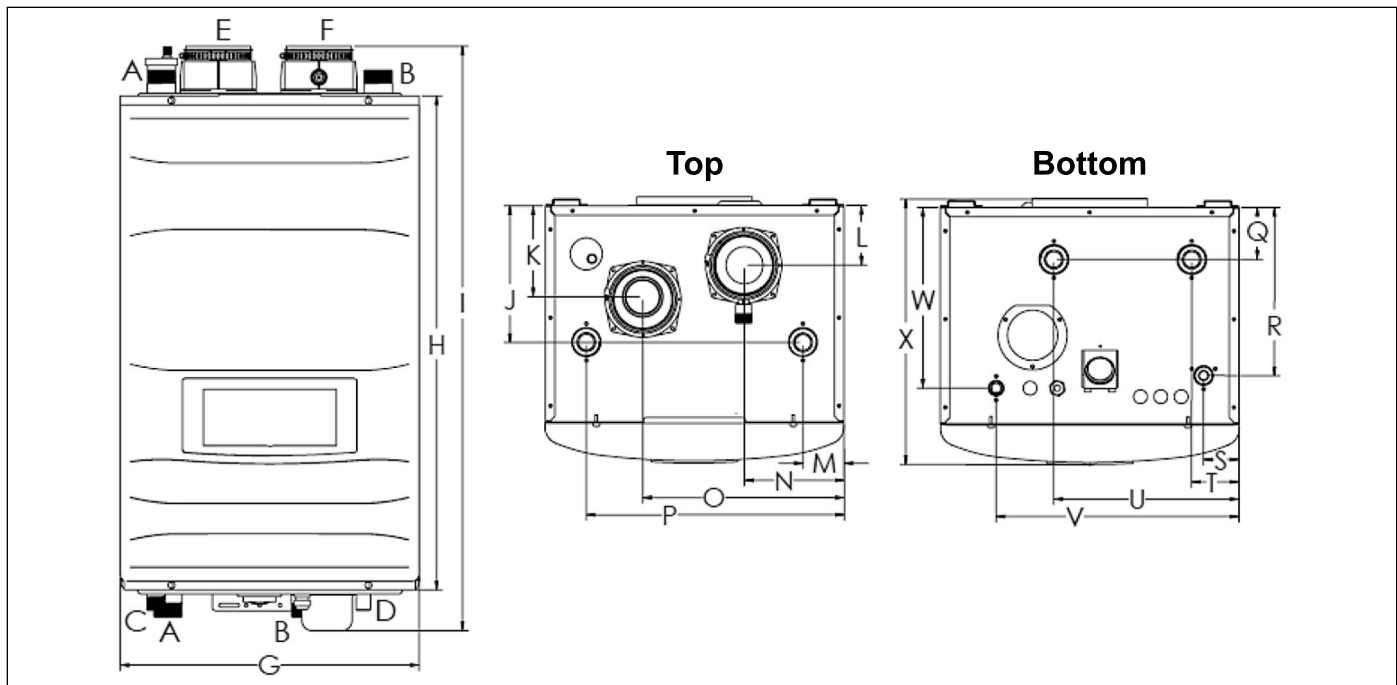

Figure 3 - Wall Mount Model Dimensions

		Description										Diameter							
A		CH Supply Adapter										1 1/4" NPT							
B		CH Return Adapter																	
C		Gas Inlet Adapter										3/4" NPT							
D		Condensate Adapter										1/2" NPT							
E		Air Intake Adapter										3"							
F		Exhaust Vent Adapter																	
Model	G	H	I	J	K	L	M	N	O	P	Q	R	S	T	U	V	W	X	
80 / 100 120 / 140	17.5	28.75	34	7.9	5.3	3.5	2.4	5.8	11.7	14.9	3.0	9.8	2.1	2.7	10.7	14.1	10.5	15.4	
175 / 199	19.7	31.9	37	7.2	5.1	3.2	3.75		12.5	17.5	4	11.1		2.2	11.7	15.8	11.8	16.8	

Table 8 - Wall Mount Specifications and Dimensions

How the Boiler Operates

Condensing technology intelligently delivers hydronic heating while maximizing efficiency. Outlined below are the features of the system and how they operate:

Stainless Steel Heat Exchanger - The highly efficient 316L stainless steel fire tube heat exchanger with internal aluminum is designed to extract all available heat from the combustion process and pass it into heat transfer fluid. The stainless steel construction provides protection for longer service life. The heat exchanger offers greater water content, providing lower system pressure and greater overall system efficiency.

10 to 1 Modulating Combustion System - The combustion system is specially designed to provide very high turn down. This combustion system will modulate the burner output to very low levels to match the system demand and achieve better overall control of the heating system for maximum efficiency and reliability.

Control - The integrated control system monitors the system and responds to internal and external signals to regulate fan speed and control output. This allows the boiler to deliver only the amount of heat energy required and nothing more.

The control can be set up to monitor outdoor temperature through an outdoor sensor to regulate boiler set point temperature, increasing overall system efficiency while providing great comfort. The system can be further enhanced by installing an indirect water heater to provide domestic hot water.

The control can regulate the output of multiple boilers through its

cascade system function by establishing one boiler as the master and the other connected boilers as followers. The master boiler requires a sensor to provide feedback on set point temperature in order to adjust heating output from the connected boilers. Multiple boiler cascaded systems offer greater system turndown and redundancy.

Electronic LCD Display - The high resolution display allows the user to monitor boiler functions. The display also provides the means to program the system parameters to maximize the efficiency of the system design.

Combustion System (Blower - Gas Valve - Mixer - Burner - Spark Ignition) - The highly efficient spark ignition combustion system uses a variable speed blower to adjust combustion as the system requires more or less energy. The negative regulated gas valve provides only the amount of fuel required to ensure clean combustion. The mixer accurately regulates the combination of gas and air throughout the modulating range to ensure high reliability. The burner is constructed of durable ceramic metal fiber for long service life.

Boiler Sensors (Inlet - Outlet - Flue - Outdoor) - Sensors provide highly accurate temperature monitoring to assure accurate system control. These sensor inputs can be monitored through the boiler control system and display.

Pressure Gauge - Allows the user to monitor system pressure.

System Safeties - The boiler is provided with many safety features to ensure reliable and safe operation. Each safety is connected to the boiler control. The boiler will alert the user if an unsafe condition occurs

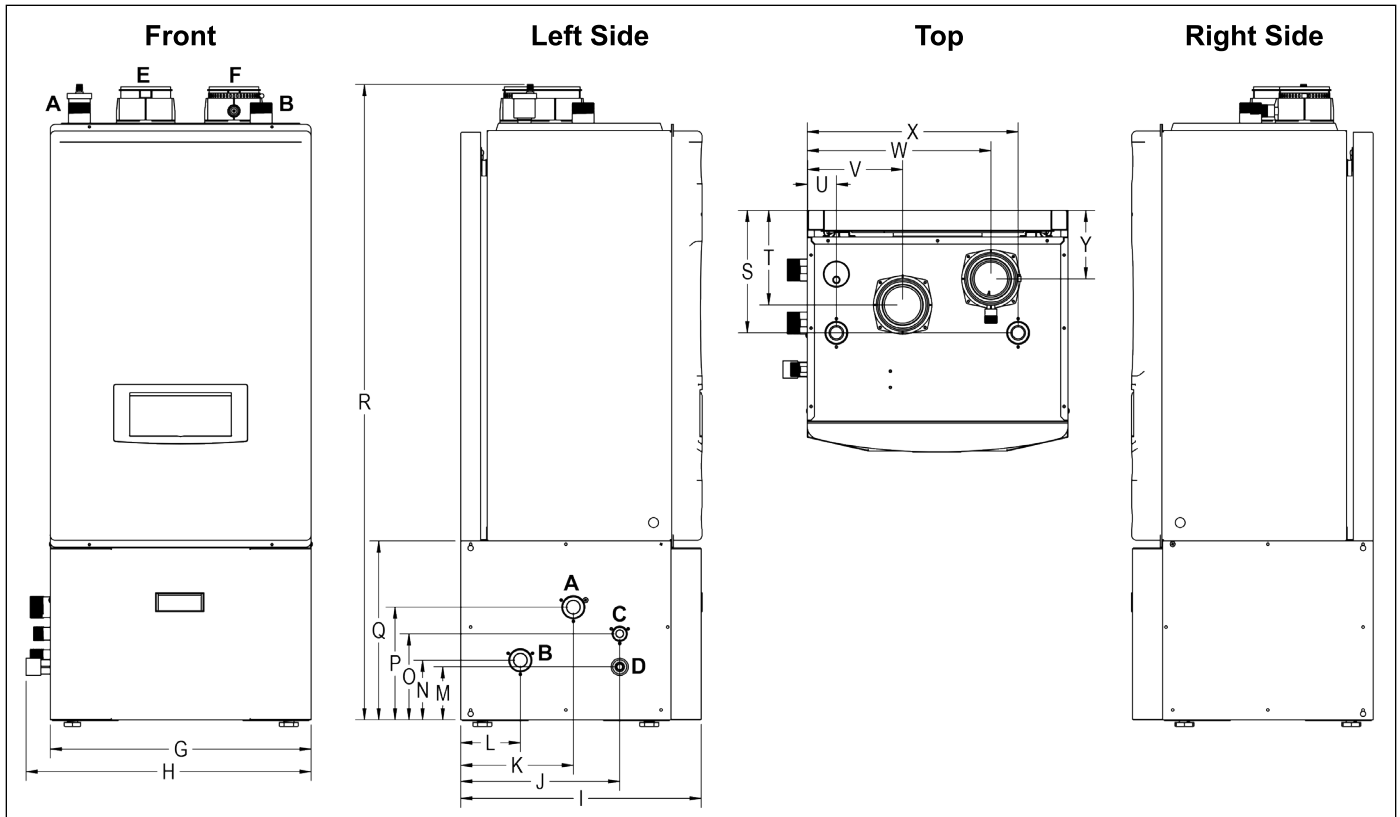

Figure 4 - Floor Model Dimensions

		Description										Diameter								
A		CH Supply Adapter										1 1/4" NPT								
B		CH Return Adapter																		
C		Gas Inlet Adapter										3/4" NPT								
D		Condensate Adapter										1/2" NPT (3/4" PVC Socket on Floor Models)								
E		Air Intake Adapter										3"								
F		Exhaust Vent Adapter																		
Model	G	H	I	J	K	L	M	N	O	P	Q	R	S	T	U	V	W	X	Y	
80 / 100 120 / 140	17.3	19.1	16.8	12.0	8.5	4.5	4.0	4.5	6.5	8.5	13.5	45.0	10.0	7.4	2.3	5.7	11.5	14.9	5.5	
175 / 199	19.7	21.5	18.1									48.0	9.2	7.1	2.2	7.2	14.0	16.0	5.2	

Table 9 - Floor Model Specifications and Dimensions

and needs to be addressed. The following are provided safeties: Flue Pressure Switch (monitors flue pressure), Burner High Limit (monitors burner plate temperature), High Limit Water Switch (monitors boiler temperature), Low Water Sensor (monitors water level in the heat exchanger), optic flame sensor (monitors flame quality), Flue Sensor (monitors flue temperature), Condensate Pressure Switch (monitors pressure to ensure condensation does not back up into boiler).

Manual Air Vent – Each boiler is equipped with an air vent to discharge air from the system during start-up.

Intake and Exhaust Adapters – The boiler is equipped with adapters to ease connection to the vent system. The adapters are provided with clamps and seals to secure field supplied piping, and test ports to ease monitoring of the combustion system. Each boiler is supplied with a 6 inch piece of CPVC that must be connected into the exhaust vent adapter.

Boiler 1 1/4" Return and 1 1/4" Supply Connection – Boilers are equipped with both top and bottom piping connections for greater installation flexibility.

Gas Connection – The boiler is equipped with a 3/4" gas connection to connect the incoming gas supply.

Field Wiring and Power Switch – Each boiler is supplied with a power switch to cut off power. The boiler is also equipped with two

front mounted terminal strips. These terminal strips are separated into low and line voltage to ease system wiring.

Condensate Trap and Hose Assembly – Each boiler has a built-in condensate trap to control the discharge of condensate produced by the boiler during normal operation. A corrugated condensate hose is also provided to ensure proper drainage of condensate into the pump or drain.

Low Water Cut Off Probe – LWCO is provided with each boiler to ensure the boiler has an adequate water level to eliminate overheating and damage to the heat exchanger.

Pump Service Mode – Allows manual operation of pumps to commission system and check pump operation.

DHW Priority – The boiler control allows connection of a DHW temperature sensor / aquastat to the low voltage terminal strip. When the aquastat calls for heat, the module activates the DHW pump, shuts down the boiler and CH pumps, and immediately sets the target outlet water temperature to 180°F (factory default). This provides automatic priority heat allocation to the indirect water heater for maximum response and recovery. The DHW pump continues for 1 minute (factory default) after the heating cycle to deliver the most possible heat.

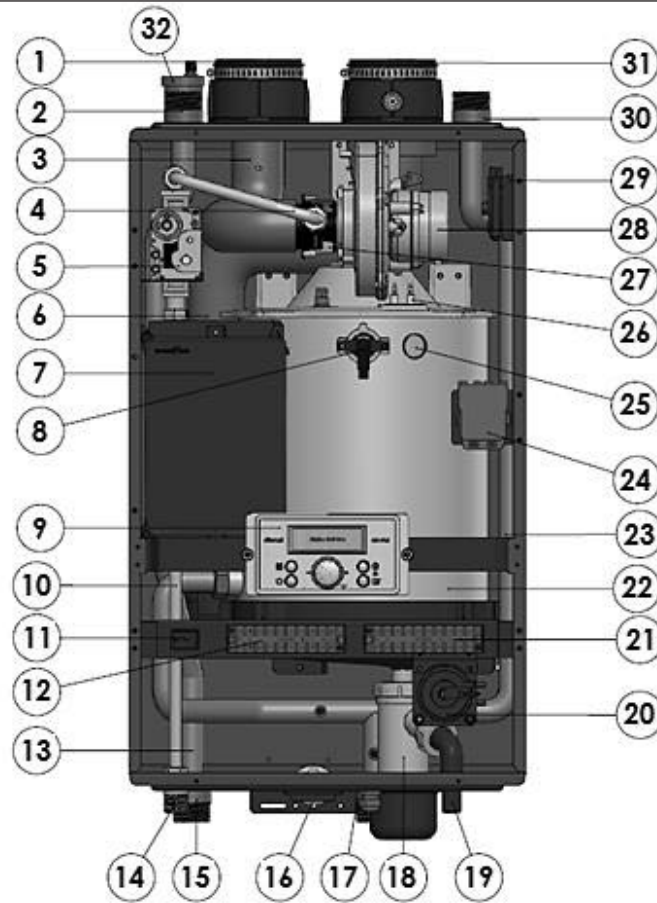

Figure 5 - Components

Number	Component Description	Number	Component Description	Number	Component Description
1	Air Intake Pipe Adapter	13	CH Supply Pipe	12	High Voltage Terminal Block
2	CH Top Supply Adapter	14	Gas Inlet Adapter	24	Ignition Transformer
3	Air / Gas Mixing Pipe	15	CH Bottom Supply Adapter	25	Flame Viewing Window
4	Gas Inlet Pipe 2	16	CH Pressure Gauge	26	Igniter Rod
5	Gas Valve	17	CH Bottom Return Adapter	27	Air / Gas Mixer
6	Exhaust Duct	18	Condensate Trap	28	BLDC Fan
7	Main PCB	19	Condensate Adapter	29	Air Pressure Switch
8	Flame Detection Sensor	20	Condensate Air Pressure Switch	30	CH Supply Adapter
9	Control Panel	21	Low Voltage Terminal Strip	31	Exhaust Vent Adapter
10	Gas Inlet Pipe 1	22	Heat Exchanger	32	Automatic Air Vent
11	Manual ON/OFF Power Switch	23	CH Return Pipe		

Table 10 - Component List

DHW / Central Heating (CH) Rotation – If a DHW call for heat is received while a central heating call is in progress, the control will start the DHW pump and shut the boiler and CH pumps off. If the central heating call is still active while the DHW call is in operation, the control will wait for 30 minutes (time adjustable by the installer) then switch back to the central heating demand. The control will switch back and forth until one of the heat demands ends.

Cascade Operation - This boiler can be configured to run with multiple boilers in a Cascade System. In a Cascade System, multiple boilers are installed, piped, and wired to cooperate in a single system. This provides many advantages over a single large capacity boiler, including increased turndown, system redundancy, and increased efficiency. A maximum of sixteen (16) units can be controlled by a single boiler designated as the "Master". Other connected boilers are designated as "Followers".

The Master controls the operational run time of the connected

Followers and modulates the connected units up or down to ensure the units are putting only the needed energy into the system, and also to ensure all connected units get even run time to balance out service requirements.

When the Master boiler receives a call for heat from a room thermostat, the Master will determine the set point. If Outdoor Reset or 0-10V is used, connect the outdoor sensor or 0-10V to the low voltage terminals provided on the Master boiler. The set point will be determined based on the programmed reset curve parameters. If Outdoor Reset or 0-10V is not used, a fixed temperature set point can be programmed into the control. **NOTE:** This set point is for the system sensor.

If the system water temperature is less than the set point - the cascade system differential (32:Cd), the control will initiate a call for heat. The Master boiler will energize the lead boiler in the cascade system. In a new system start-up this will be the Master.

The boiler will fire at its ignition speed and then modulate its firing rate to maintain the set point. If the first boiler reaches 80% of its firing rate, the Master will modulate down and split the load in half with the next unit in the system service rotation. At this point, the Master will fire the second boiler in the system. If there are more than two boilers in the system, the same principle will be applied. Once the lead boiler reaches 80% of its firing rate, it will modulate down and split the total amount of load by the total number of units in the cascaded system.

If the set point still cannot be met, the Master will continue firing more Followers until either the heat demand is met or all boilers in the cascade system are firing at the maximum rate. As the heat demand decreases, all operating boilers will modulate down according to the heating load. The first boiler to modulate down to 30% will shut off when the system sensor is at the target temperature. The same principle will be applied to the remaining boilers in operation until the heating demand or system sensor is satisfied. When the demand is satisfied, the boilers will turn off. However, the system pump will continue to operate until the heating demand is satisfied.

If 0-10V is used, connect the 0-10V to the low voltage terminals provided on the Cascade Master. The set point will be determined based on the programmed parameters. If 0-10V is not used, a fixed temperature set point can be programmed into the control.

DHW Priority - Any follower on the cascade loop can be selected for DHW priority. When using more than one unit for DHW priority an Aquastat must be used. During a DHW demand all boilers connected with an Aquastat will fire simultaneously to satisfy the demand. If the central heating call is still active while the DHW call is in operation, the control will wait for 30 minutes (time adjustable by the installer) then switch back to the central heating demand. The control will switch back and forth until one of the heat demands ends.

CAUTION

When installing a cascaded system, it is important that the boilers are the same model. Failure to ensure the boilers are the same model will result in improper system operation, wasted time, money, and possible property damage and personal injury. Such damages ARE NOT covered by product warranty.

J. Wall-Mounting (Wall Mount Models Only)

WARNING

The boiler must be installed on a wall that can bear its weight (more than 110 lbs. when fully plumbed and full of water). Installing the boiler on a wall which cannot support its weight could result in property damage, personal injury, or death.

The boiler may be installed on any suitable internal wall (suitable sound-proofing may be required when installing onto a stud partition wall).

WARNING

This boiler is too heavy for one person to lift. It is highly recommended to install the boiler with two people. Use caution as to not drop the boiler, which could damage the boiler and cause property damage and/or severe personal injury. Verify that the boiler is properly and securely mounted before leaving unsupervised. Failure to comply with the above and properly mount the boiler could result in substantial property damage, severe personal injury, or death.

This wall mounting system is not seismic rated and should not be applied as such. Failure to comply with the above and properly mount the boiler could result in substantial property damage, severe personal injury, or death.

Positioning the Boiler on the Wall

1. Attach the wall bracket on the location where you want to install the boiler. Ensure it is level and on stud (16" centers) before proceeding.
2. Mark the four drill holes with a pencil or marker. Remove the wall bracket.
3. Drill four (4) holes using a 5/32 drill bit at the marked hole locations.
4. Mount the wall bracket to the wall with the four (4) included anchor bolts. Ensure the mounted bracket is level. See Figure 6A.
5. Align the boiler bracket grooves on the back of the boiler with the tongues on the wall bracket and hang the boiler on the bracket. See Figure 6B.

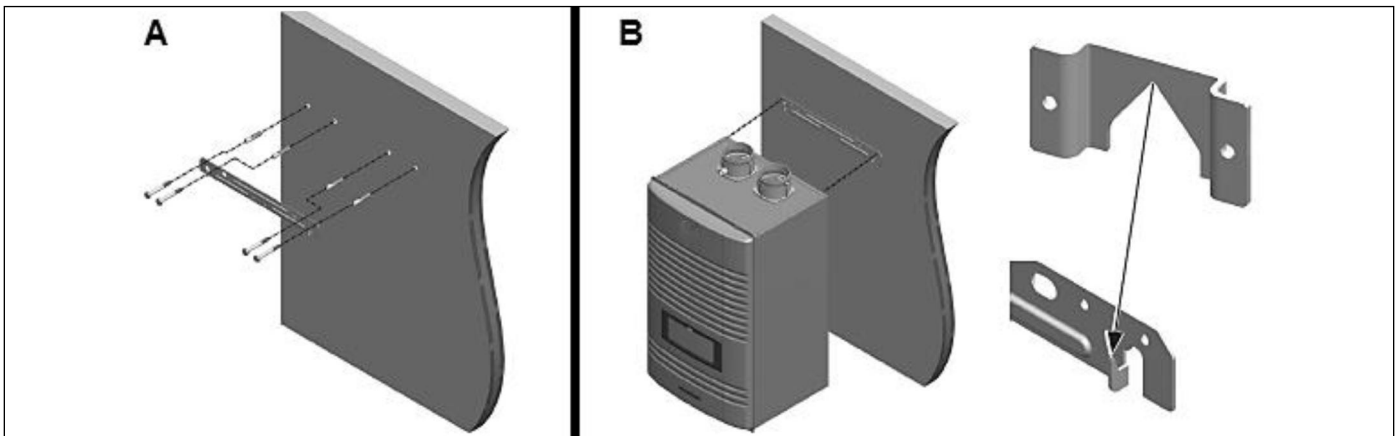

Figure 6 - Wall-Mounting the Boiler

Part 4 - Water Piping

WARNING

Failure to follow the instructions in this section WILL VOID the warranty and may result in property damage, severe personal injury, or death.

CAUTION

Do not apply a torch within 12" of the boiler. If sweat connections are used, sweat tubing to the adapter before fitting adapter to the water connections on the boiler. Damages due to improper installation practices ARE NOT covered by warranty.

Dielectric unions or galvanized steel fittings must not be used in a system with this boiler. Doing so WILL VOID the warranty. Use only copper, brass, or stainless steel fittings. Teflon thread sealant must be used on all connections.

A. General Plumbing Guidelines

CAUTION

Use two wrenches when tightening water piping at the boiler. Use one wrench to prevent the boiler return or supply line from turning. Failure to prevent piping connections from turning could cause damage to boiler components.

The boiler control module uses temperature sensors to provide both high limit protection and modulating temperature control. The control module also provides low water protection by sensing the water level in the heat exchanger. Some codes / jurisdictions may require additional external controls.

The water connections must be installed in accordance with all local and national plumbing codes, or any applicable standard which prevails. The return and supply ports are 1 1/4" on all models.

- Pipe material must be suitable to meet local codes and industry standards.
- The pipe must be cleaned and without blemish before any connections are made.
- See Tables 11 and 12 for minimum CH pipe sizing.
- Isolation (shutoff valves) should be used to ease future servicing.
- All piping should be insulated.

It is recommended to install a sweat shut-off valve and a union in the return and supply piping to ease future servicing. If there is a backflow preventer or any type of a no return valve in the system, install an additional tee here, suitable for an expansion tank.

B. Backflow Preventer

It may be recommended to use a backflow preventer - check local codes. If a backflow preventer or a no return valve is used, a thermal expansion tank must be installed on the cold water supply between the boiler and the valve.

WARNING

To control thermal expansion, a thermal expansion tank should be installed in systems with an installed backflow preventer. DO NOT use a closed type expansion tank. Follow expansion tank manufacturer's specifications to properly size an expansion tank to the installation. Failure to properly accommodate thermal expansion could result in property damage, severe personal injury, or death.

C. Expansion Tank Expansion Tank

1. Ensure that the expansion tank is designed and sized to correctly handle system water volume and temperature. Check technical specifications for the water content of this boiler.

WARNING

Expansion tanks must be sized according to total system volume. This includes all length of pipe, all fixtures, boilers, etc. Failure to properly accommodate thermal expansion could result in property damage, severe personal injury, or death.

CAUTION

Undersized expansion tanks cause system water to be lost from the relief valve, causing make-up water to be added. Eventual boiler failure can result due to excessive make-up water addition. **SUCH FAILURE IS NOT COVERED BY WARRANTY.**

2. The expansion tank must be located as shown in Applications, this manual, or following recognized design methods. See expansion tank manufacturer's instructions for details.

3. Connect the expansion tank to the air separator only if the air separator is on the suction side of the circulator. Always install the system fill connection at the same point as the expansion tank connection to the system.

CAUTION

DO NOT install automatic air vents on closed type expansion tank systems. Air must remain in the system and return to the tank to provide an air cushion. An automatic air vent would cause air to leave the system, resulting in improper operation of the expansion tank.

Diaphragm (or Bladder) Expansion Tank

Always install an automatic air vent on top of the air separator to remove residual air from the system.

D. Piping the Boiler

CAUTION

Use at least the MINIMUM pipe size for all boiler loop piping This is to avoid the possibility of inadequate flow through the boiler. Using less than the required minimum pipe size and piping could result in system problems, property damage, and premature boiler failure. Such problems ARE NOT covered by product warranty.

Use both thread tape and pipe dope to connect to the 1 1/4" CH return and supply. Tankless isolation valves between the city water supply and tank inlet are recommended for ease of service.

E. Applications

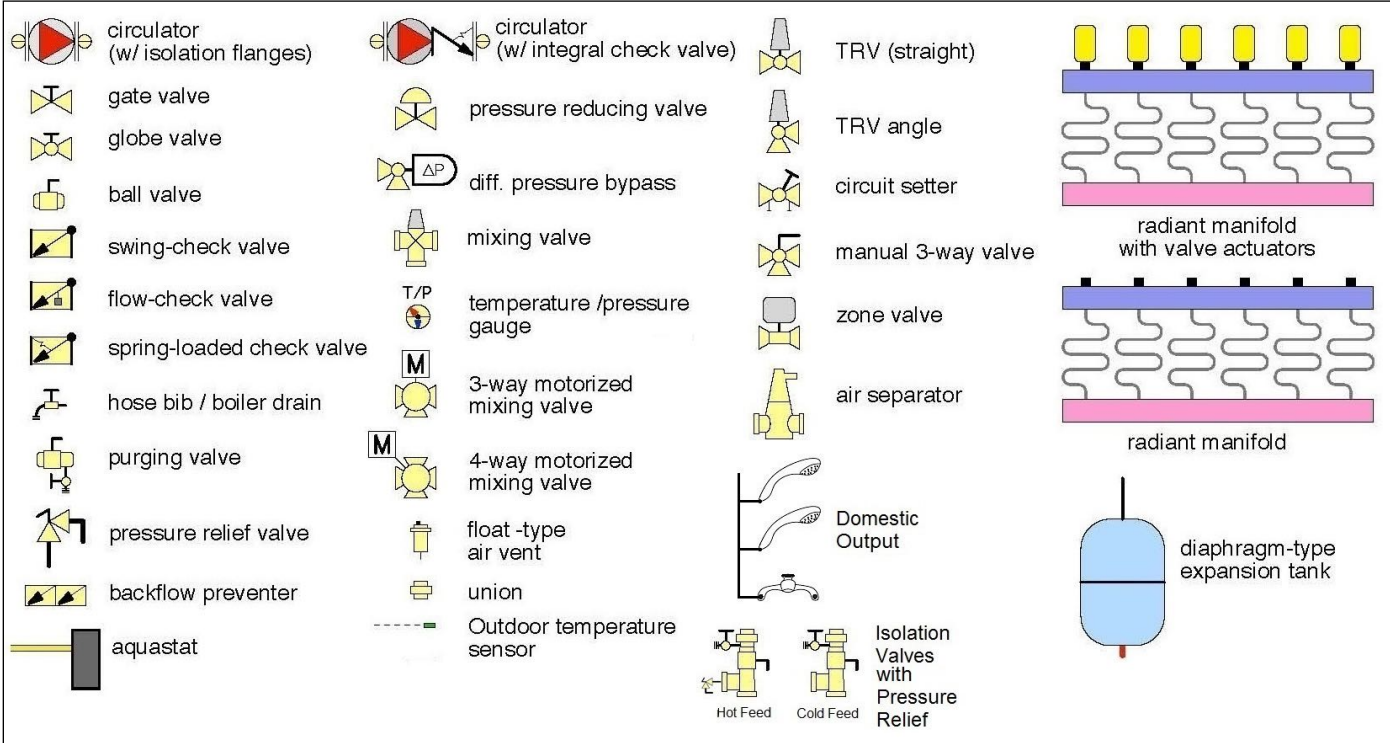

Figure 7 - Piping Symbol Legend

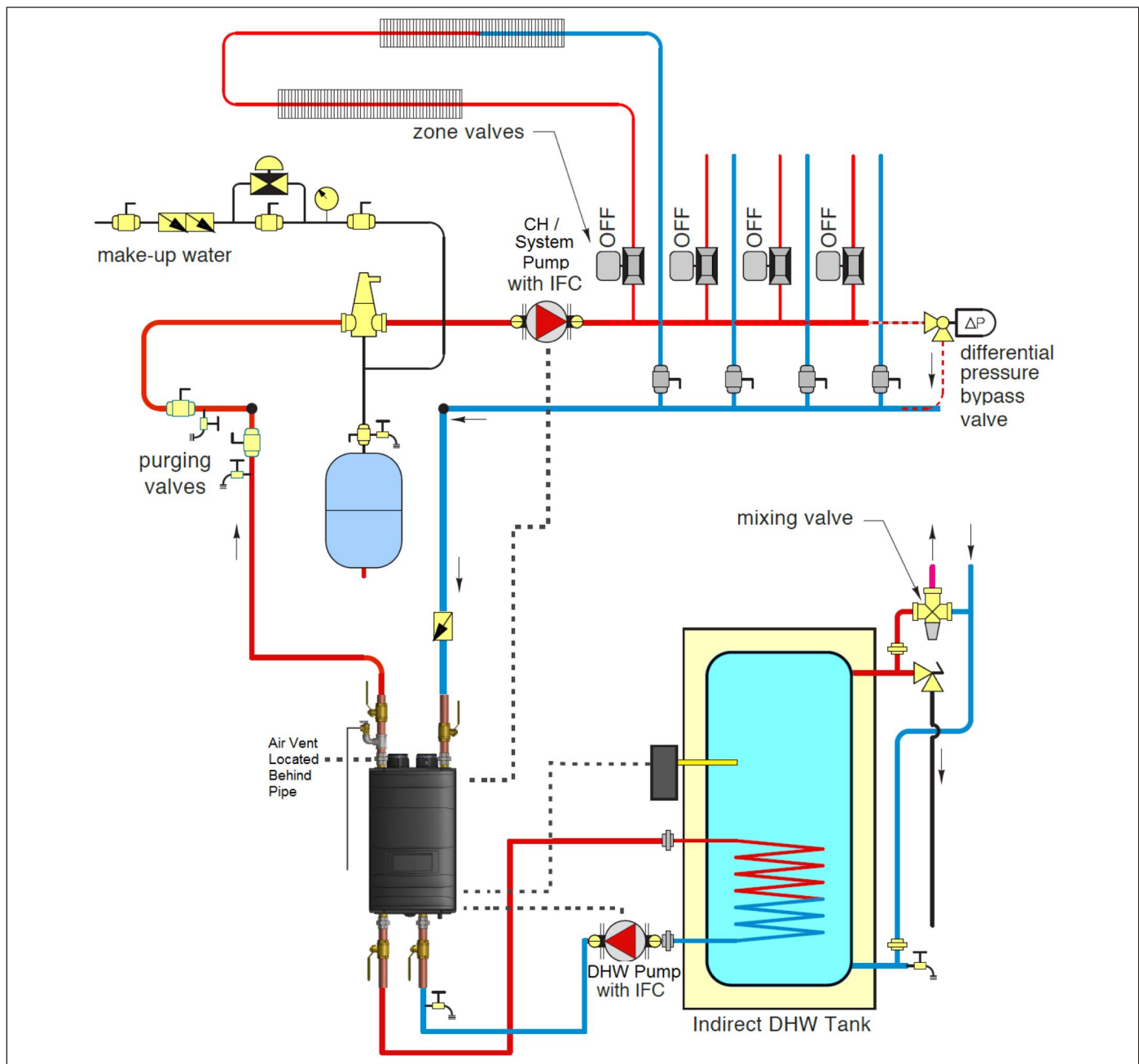

Figure 8 - Zoning with Zone Valves and Indirect Water Heating - Direct Piping

NOTES:

1. This drawing is meant to show system piping concept only. Installer is responsible for all equipment and detailing required by local codes.
2. All closely spaced tees shall be within 4 pipe diameters center to center spacing.
3. A minimum of 6 pipe diameters of straight pipe shall be installed upstream and downstream of all closely spaced tees.
4. The **minimum** pipe size of DHW piping should be $\frac{3}{4}$ " diameter. See Table 11 for **minimum** CH pipe sizing.
5. Circulators are shown with isolation flanges. The alternative is standard flanges with full port ball valves. Purge valves can be used with circulator flanges as an alternative.
6. Install a minimum of 12 diameters of straight pipe upstream of all circulators.
7. **VERY IMPORTANT** – Minimum flow rates outlined in this manual must be maintained through the heat exchanger to minimize short cycling.
8. In a valve-based system, each heating zone has a zone valve which opens when that zone calls for heat. Each zone thermostat is wired to its corresponding zone valve. Contacts in the zone valves provide a signal to the boiler to operate when there is a call for heat.
9. Install a check valve on the return line to the boiler.

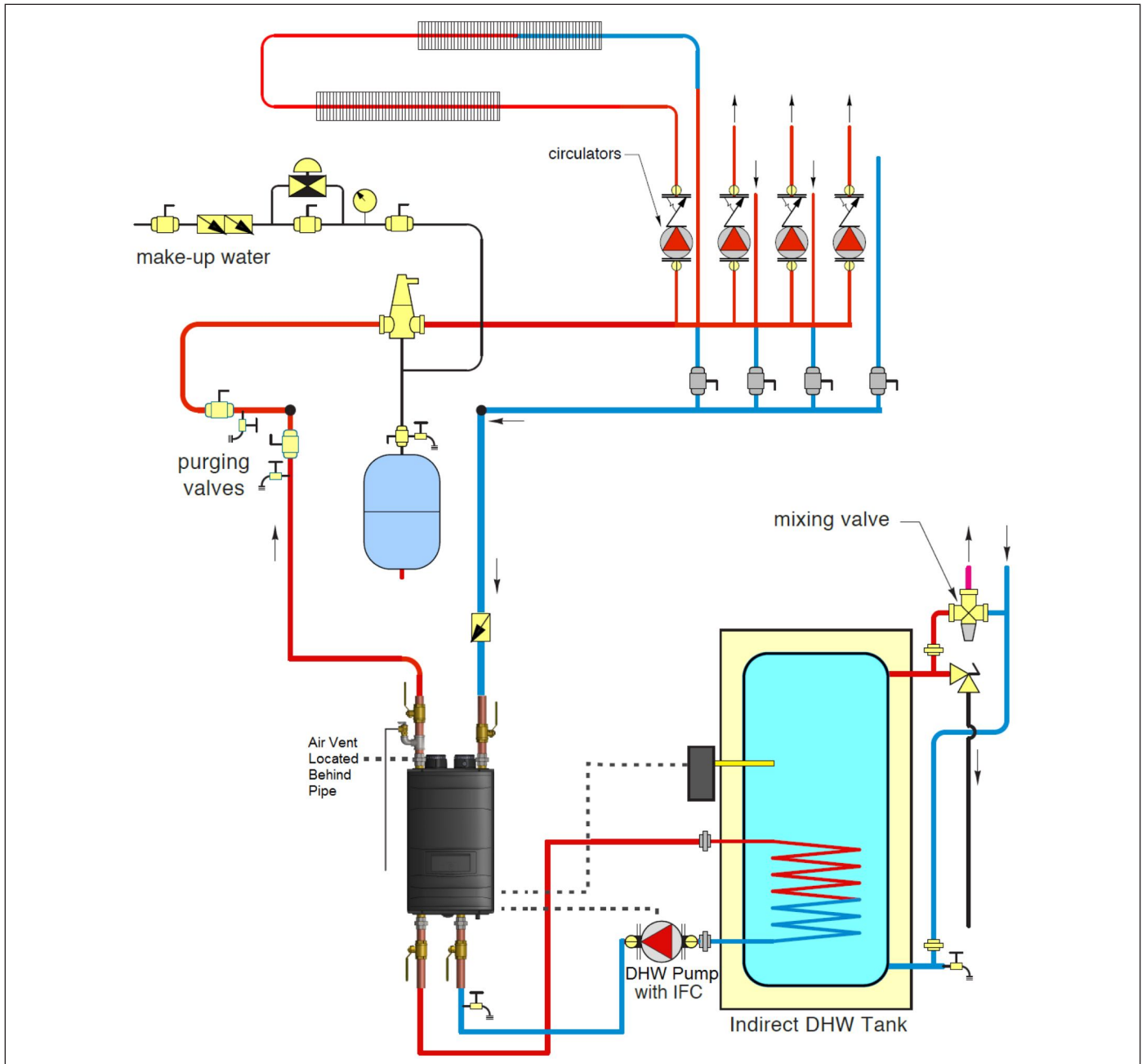

Figure 9 - Zoning with Pumps and Indirect Water Heating - Direct Piping

NOTES:

1. This drawing is meant to show system piping concept only. Installer is responsible for all equipment and detailing required by local codes.
2. All closely spaced tees shall be within 4 pipe diameters center to center spacing.
3. A minimum of 6 pipe diameters of straight pipe shall be installed upstream and downstream of all closely spaced tees.
4. The **minimum** pipe size of DHW piping should be $\frac{3}{4}$ " diameter. See Table 11 for **minimum** CH pipe sizing.
5. Circulators are shown with isolation flanges. The alternative is standard flanges with full port ball valves. Purge valves can be used with circulator flanges as an alternative.
6. Install a minimum of 12 diameters of straight pipe upstream of all circulators.
7. **VERY IMPORTANT** – Minimum flow rates outlined in this manual must be maintained through the heat exchanger to minimize short cycling.
8. Each heating zone of a pump-based system has its own circulator with turns on when a zone thermostat calls for heat.
9. Install a check valve on the return line to the boiler.

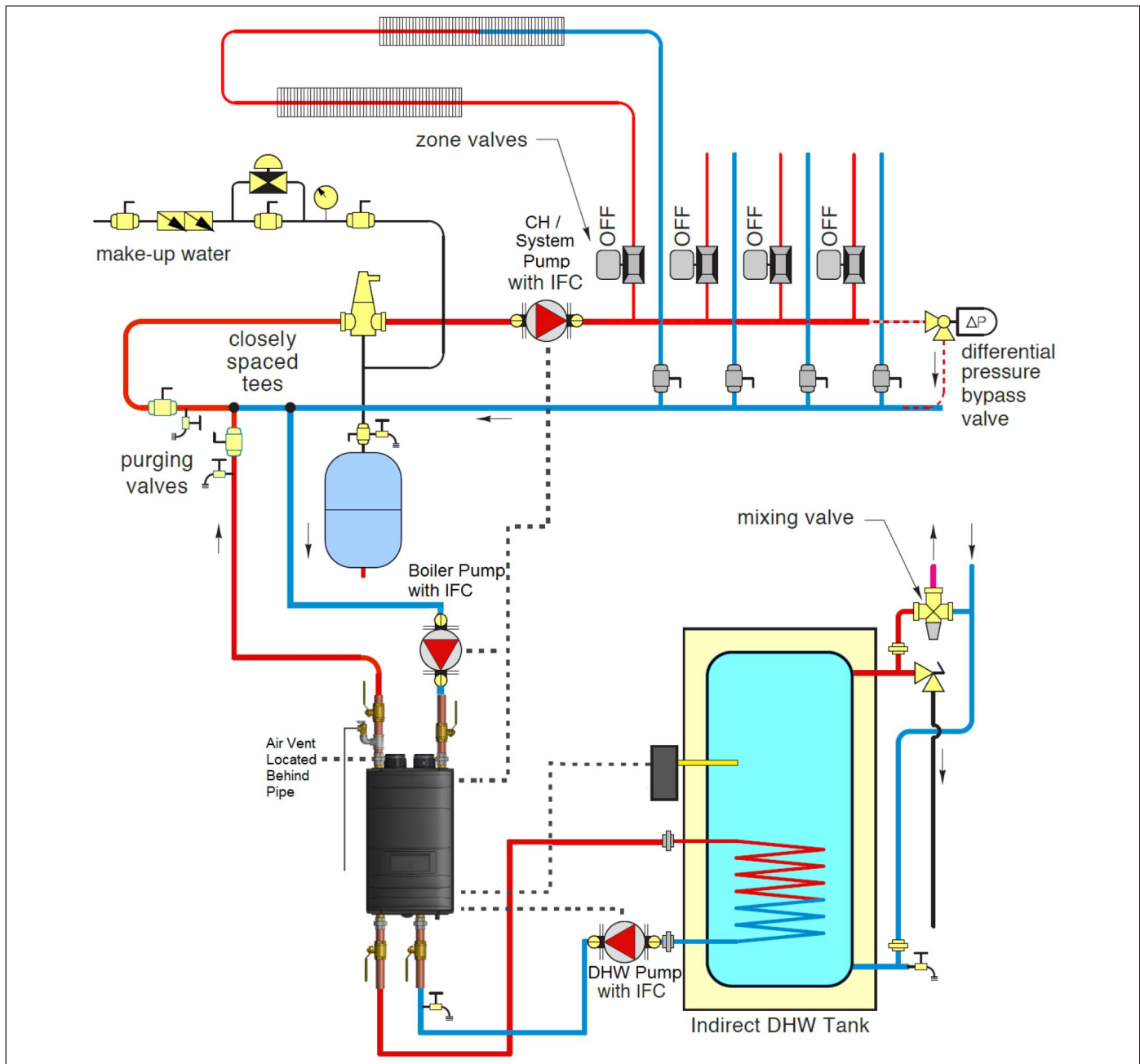

Figure 10 - Zoning with Zone Valves and Indirect Water Heating - Primary / Secondary Piping

NOTES:

1. This drawing is meant to show system piping concept only. Installer is responsible for all equipment and detailing required by local codes.
2. All closely spaced tees shall be within 4 pipe diameters center to center spacing.
3. A minimum of 6 pipe diameters of straight pipe shall be installed upstream and downstream of all closely spaced tees.
4. The **minimum** pipe size of DHW piping should be ¾" diameter. See Table 11 for **minimum** CH pipe sizing.
5. Circulators are shown with isolation flanges. The alternative is standard flanges with full port ball valves. Purge valves can be used with circulator flanges as an alternative.
6. Piping shown is Primary/Secondary. System flow (secondary loop) must be greater than the boiler's primary loop flow.
7. Install a minimum of 12 diameters of straight pipe upstream of all circulators.
8. **VERY IMPORTANT** – Minimum flow rates outlined in this manual must be maintained through the heat exchanger to minimize short cycling.
9. In a valve-based system, each heating zone has a zone valve which opens when that zone calls for heat. Each zone thermostat is wired to its corresponding zone valve. Contacts in the zone valves provide a signal to the boiler to operate when there is a call for heat.
10. If Boiler Pump on the return line does not have an internal flow check, install a check valve on the return line to the boiler.

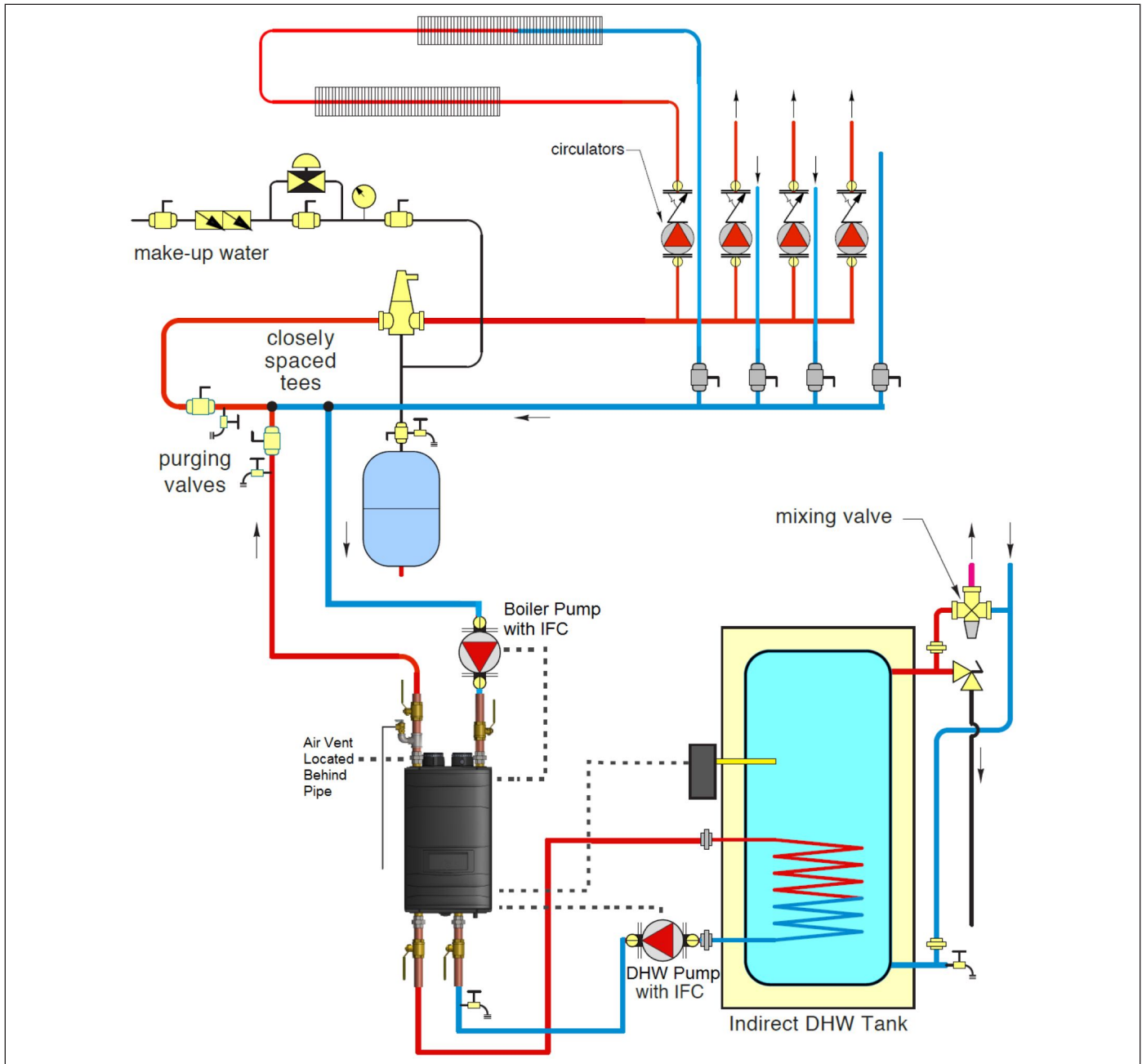

Figure 11 - Zoning with Pumps and Indirect Water Heating - Primary / Secondary Piping

NOTES:

1. This drawing is meant to show system piping concept only. Installer is responsible for all equipment and detailing required by local codes.
2. All closely spaced tees shall be within 4 pipe diameters center to center spacing.
3. A minimum of 6 pipe diameters of straight pipe shall be installed upstream and downstream of all closely spaced tees.
4. The **minimum** pipe size of DHW piping should be $\frac{3}{4}$ " diameter. See Table 11 for **minimum** CH pipe sizing.
5. Circulators are shown with isolation flanges. The alternative is standard flanges with full port ball valves. Purge valves can be used with circulator flanges as an alternative.
6. Piping shown is Primary/Secondary. System flow (secondary loop) must be greater than the boiler's primary loop flow.
7. Install a minimum of 12 diameters of straight pipe upstream of all circulators.
8. **VERY IMPORTANT** – Minimum flow rates outlined in this manual must be maintained through the heat exchanger to minimize short cycling.
9. Each heating zone of a pump-based system has its own circulator with turns on when a zone thermostat calls for heat.
10. If Boiler Pump on the return line does not have an internal flow check, install a check valve on the return line to the boiler.

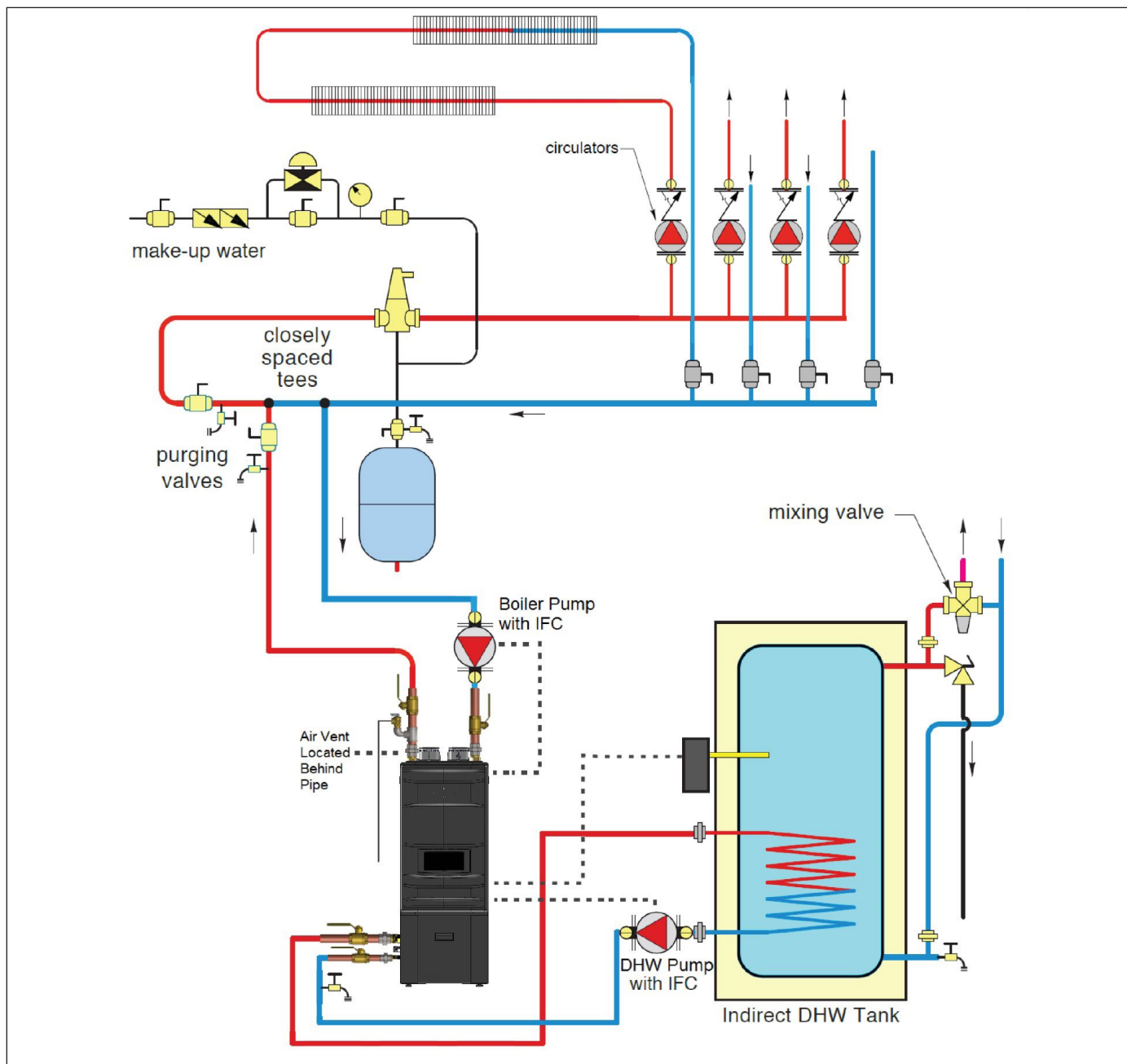

Figure 12 - Zoning with Pumps and Indirect Water Heating - Primary / Secondary Piping - Floor Model

NOTES:

1. This drawing is meant to show system piping concept only. Installer is responsible for all equipment and detailing required by local codes.
2. All closely spaced tees shall be within 4 pipe diameters center to center spacing.
3. A minimum of 6 pipe diameters of straight pipe shall be installed upstream and downstream of all closely spaced tees.
4. The **minimum** pipe size of DHW piping should be ¾" diameter. See Table 11 for **minimum** CH pipe sizing.
5. Circulators are shown with isolation flanges. The alternative is standard flanges with full port ball valves. Purge valves can be used with circulator flanges as an alternative.
6. Piping shown is Primary/Secondary. System flow (secondary loop) must be greater than the boiler's primary loop flow.
7. Install a minimum of 12 diameters of straight pipe upstream of all circulators.
8. **VERY IMPORTANT** – Minimum flow rates outlined in this manual must be maintained through the heat exchanger to minimize short cycling.
9. Each heating zone of a pump-based system has its own circulator with turns on when a zone thermostat calls for heat.
10. If Boiler Pump on the return line does not have an internal flow check, install a check valve on the return line to the boiler.

NOTE: The piping configuration of the Floor Model can be changed from the left to the right side of the boiler.

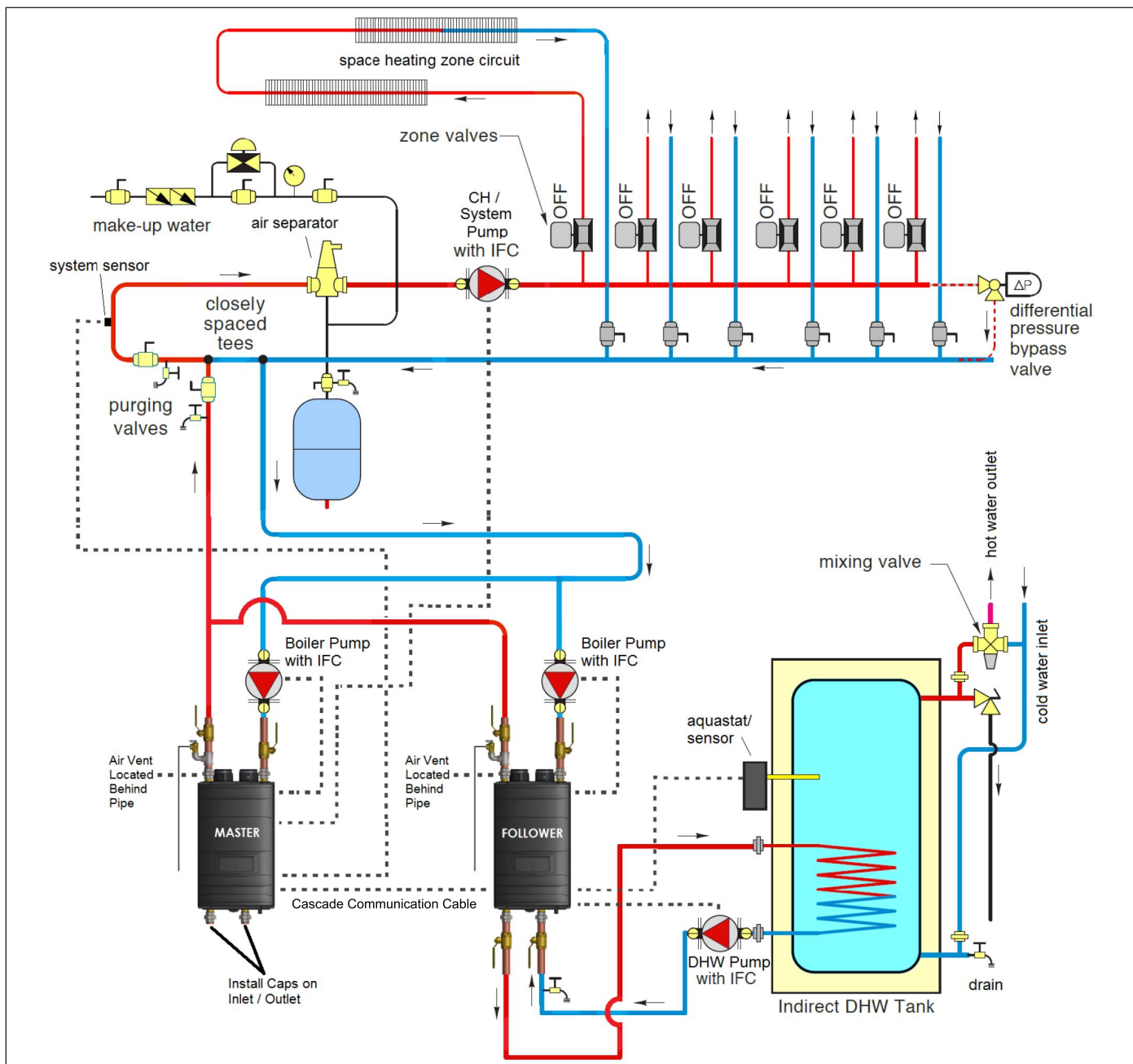

Figure 13 - Cascaded System - Zoning with Zone Valves and Indirect Water Heating - Primary / Secondary Piping

NOTES:

1. This drawing is meant to show system piping concept only. Installer is responsible for all equipment and detailing required by local codes.
2. All closely spaced tees shall be within 4 pipe diameters center to center spacing.
3. A minimum of 6 pipe diameters of straight pipe shall be installed upstream and downstream of all closely spaced tees.
4. The **minimum** pipe size of DHW piping should be ¾" diameter. See Table 12 for **minimum** CH pipe sizing.
5. Circulators are shown with isolation flanges. The alternative is standard flanges with full port ball valves. Purge valves can be used with circulator flanges as an alternative.
6. Piping shown is Primary/Secondary. System flow (secondary loop) must be greater than the boiler's primary loop flow.
7. Install a minimum of 12 diameters of straight pipe upstream of all circulators.
8. **VERY IMPORTANT** – Minimum flow rates outlined in this manual must be maintained through the heat exchanger to minimize short cycling.
9. In a valve-based system, each heating zone has a zone valve which opens when that zone calls for heat. Each zone thermostat is wired to its corresponding zone valve. Contacts in the zone valves provide a signal to the boiler to operate when there is a call for heat.
10. If Boiler Pump on the return line does not have an internal flow check, install a check valve on the return line to the boiler.

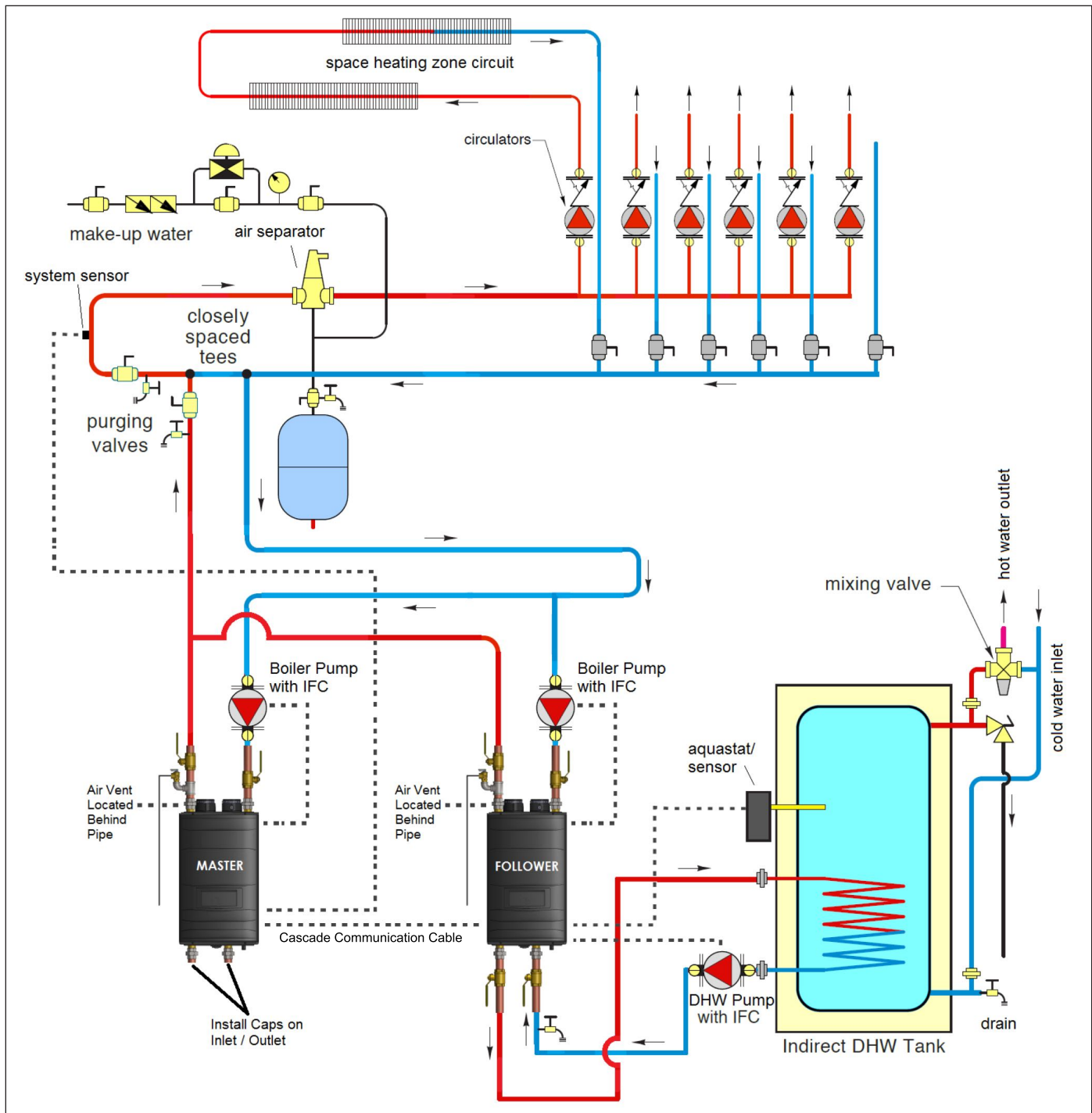

Figure 14 - Cascaded System - Zoning with Pumps and Indirect Water Heating - Primary / Secondary Piping

NOTES:

1. This drawing is meant to show system piping concept only. Installer is responsible for all equipment and detailing required by local codes.
2. All closely spaced tees shall be within 4 pipe diameters center to center spacing.
3. A minimum of 6 pipe diameters of straight pipe shall be installed upstream and downstream of all closely spaced tees.
4. The **minimum** pipe size of DHW piping should be $\frac{3}{4}$ " diameter. See Table 12 for **minimum** CH pipe sizing.
5. Circulators are shown with isolation flanges. The alternative is standard flanges with full port ball valves. Purge valves can be used with circulator flanges as an alternative.
6. Piping shown is Primary/Secondary. System flow (secondary loop) must be greater than the boiler's primary loop flow.
7. Install a minimum of 12 diameters of straight pipe upstream of all circulators.
8. **VERY IMPORTANT** – Minimum flow rates outlined in this manual must be maintained through the heat exchanger to minimize short cycling.
9. Each heating zone of a pump-based system has its own circulator with turns on when a zone thermostat calls for heat.
10. If Boiler Pump on the return line does not have an internal flow check, install a check valve on the return line to the boiler.

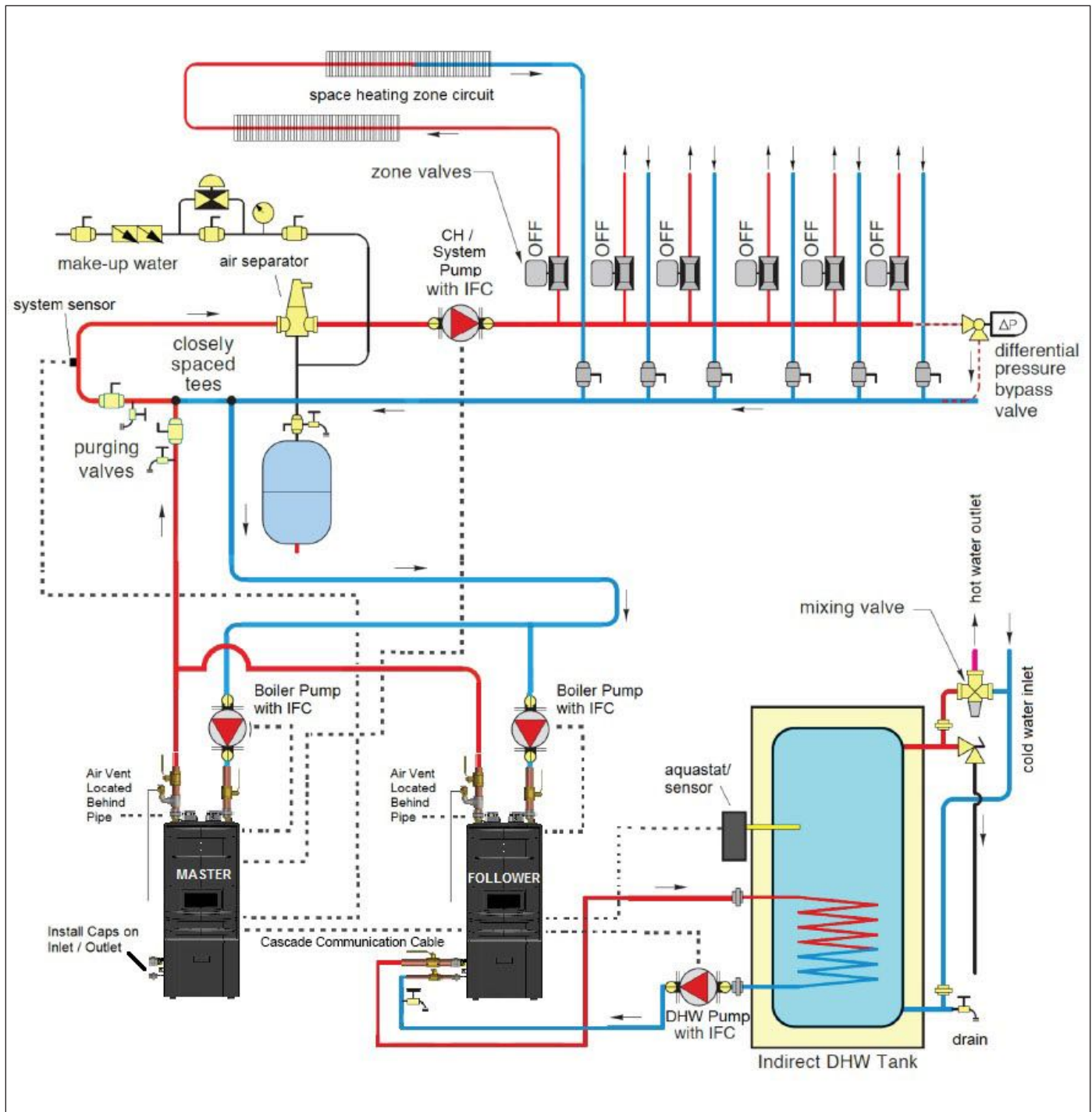

Figure 15 - Cascaded System - Zoning with Pumps and Indirect Water Heating - Primary / Secondary Piping - Floor Model

NOTES:

1. This drawing is meant to show system piping concept only. Installer is responsible for all equipment and detailing required by local codes.
2. All closely spaced tees shall be within 4 pipe diameters center to center spacing.
3. A minimum of 6 pipe diameters of straight pipe shall be installed upstream and downstream of all closely spaced tees.
4. The **minimum** pipe size of DHW piping should be $\frac{3}{4}$ " diameter. See Table 12 for **minimum** CH pipe sizing.
5. Circulators are shown with isolation flanges. The alternative is standard flanges with full port ball valves. Purge valves can be used with circulator flanges as an alternative.
6. Piping shown is Primary/Secondary. System flow (secondary loop) must be greater than the boiler's primary loop flow.
7. Install a minimum of 12 diameters of straight pipe upstream of all circulators.
8. **VERY IMPORTANT** – Minimum flow rates outlined in this manual must be maintained through the heat exchanger to minimize short cycling.
9. Each heating zone of a pump-based system has its own circulator with turns on when a zone thermostat calls for heat.
10. If Boiler Pump on the return line does not have an internal flow check, install a check valve on the return line to the boiler.

NOTE: The piping configuration of the Floor Model can be changed from the left to the right side of the boiler.

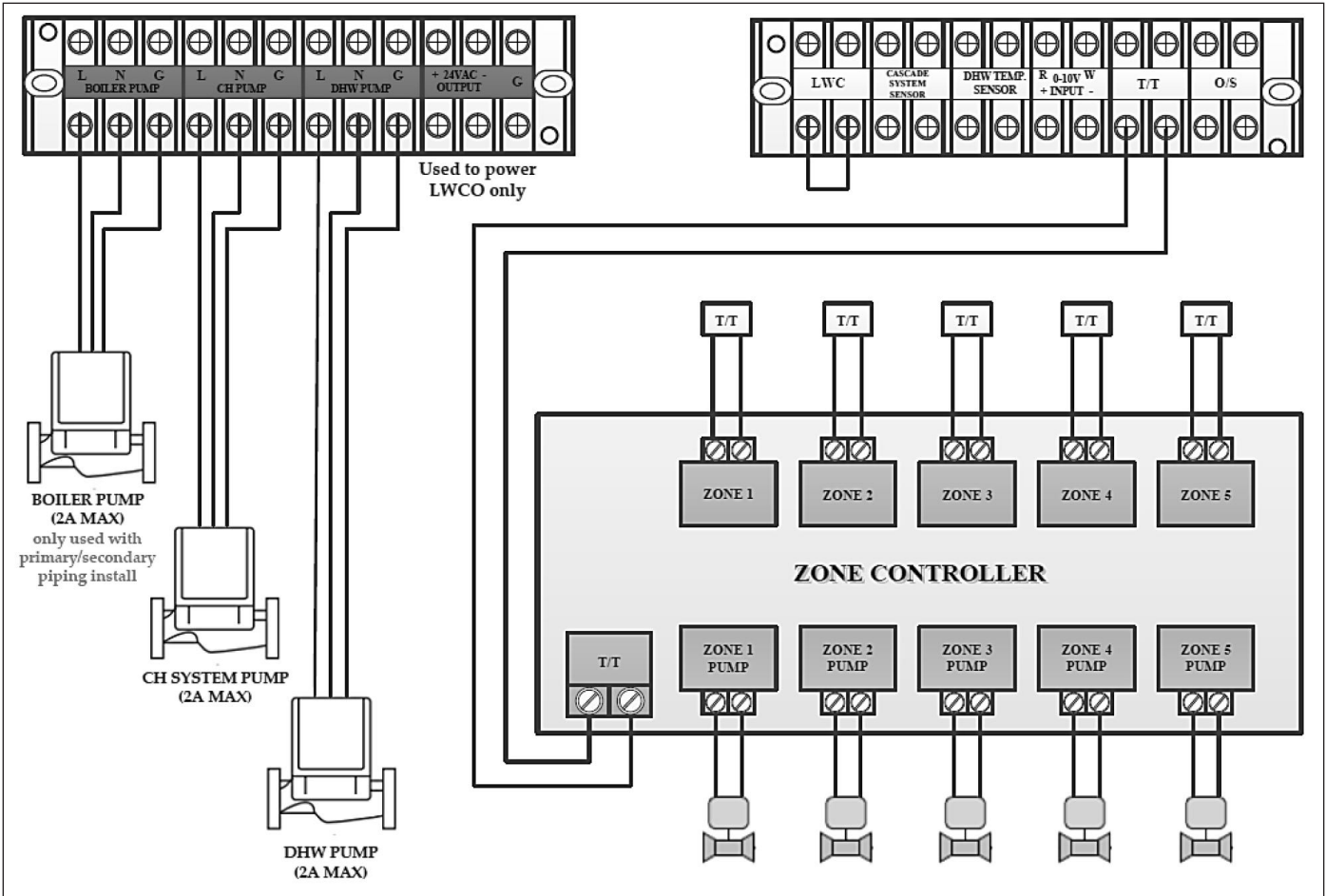

Figure 16 - Wiring - Zoning with Zone Valves and Indirect Water Heating

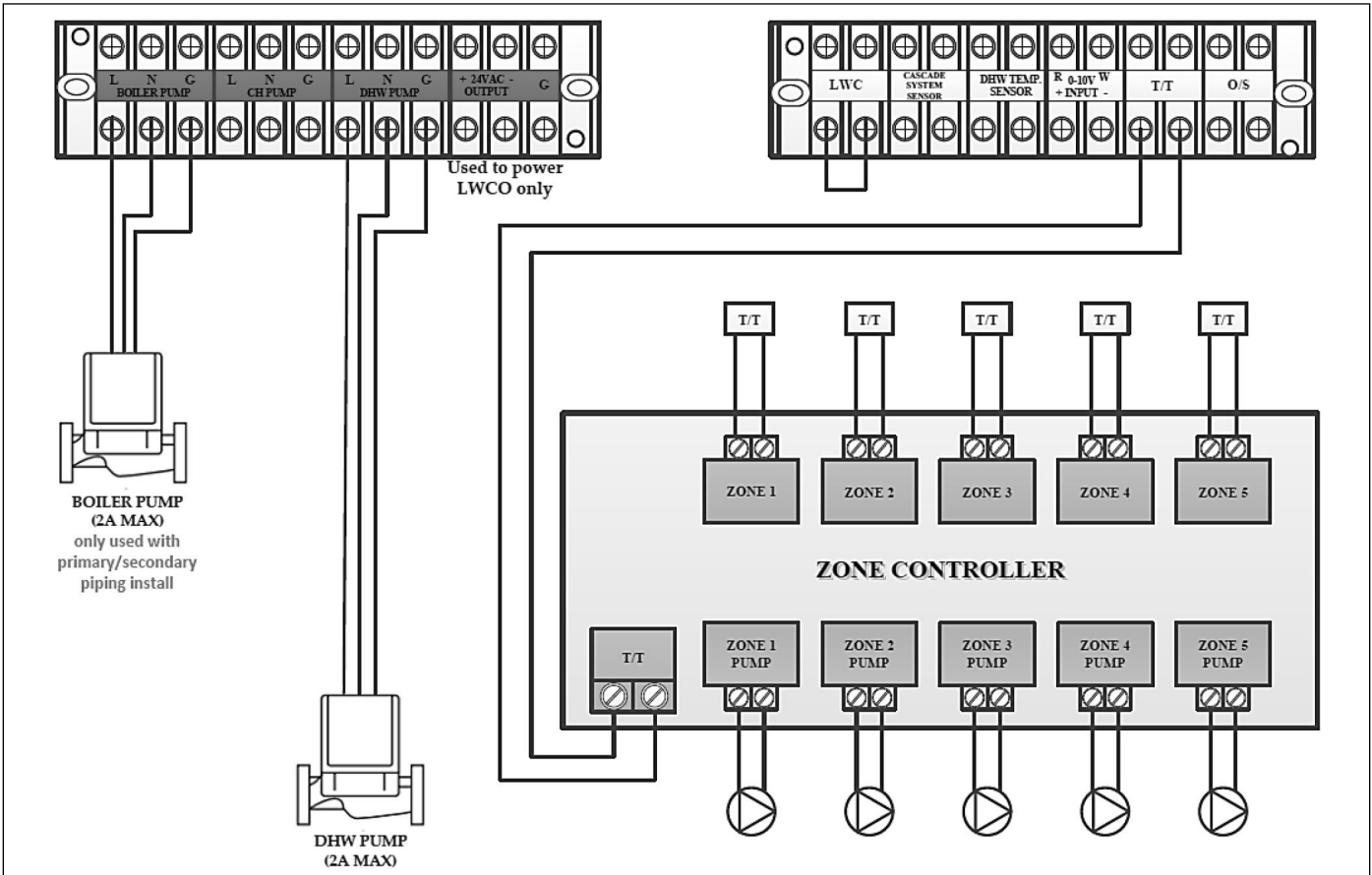

Figure 17 - Wiring - Zoning with Pumps and Indirect Water Heating

F. Circulator Sizing

The heat exchanger has a pressure drop that must be considered in your system design. Refer to the chart below for pressure drop through the heat exchanger.

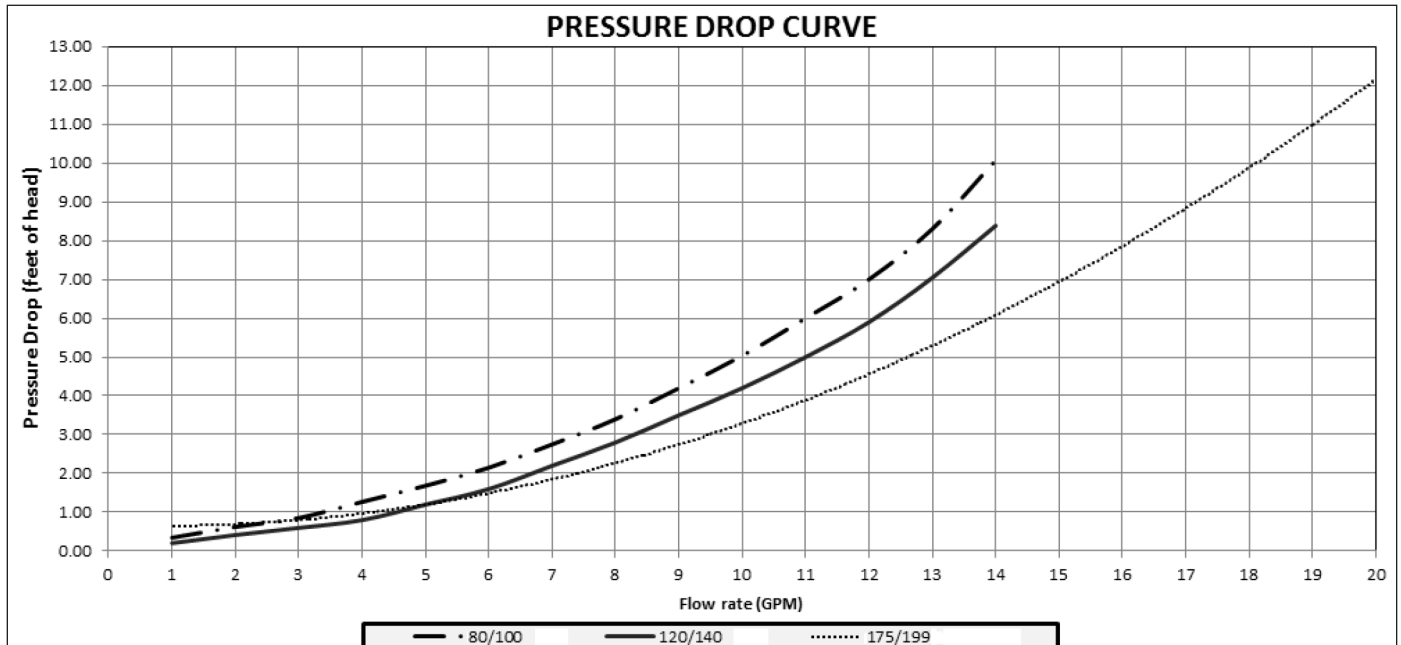

Figure 18 - This chart represents heat exchanger pressure losses.

System Temperature Rise Chart								
Model	Minimum Pipe Size	20°F ΔT			30°F ΔT		40°F ΔT	
		Absolute Minimum Flow Rate (GPM)	Flow Rate (GPM)	Head (FT)	Flow Rate (GPM)	Head (FT)	Flow Rate (GPM)	Head (FT)
80	1"	1.3	7.6	3.1	5.1	1.8	3.8	1.2
100		1.5	9.5	4.7	6.3	2.3	4.8	1.7
120		1.7	11.4	5.4	7.6	2.5	5.7	1.6
140		2.0	13.3	7.3	8.9	3.5	6.7	2.1
175	1 1/4"	2.5	16.6	8.5	11.1	4.0	8.3	2.5
199		2.5	18.9	11.0	12.6	5.0	9.5	3.0

Table 11 - Boiler Flow Rates - The smallest zone must meet the absolute minimum flow rate to ensure proper operation.

Model	Number of Units Cascaded							
	2	3	4	5	6	7	8	
80	1 1/4"	1 1/4"	1 1/2"	2"	2"	2"	3"	
100			2"					
120			2"					
140	1 1/2"	1 1/2"	3"	3"	3"	3"		
175								
199	2"	2"	3"	3"	3"	3"	4"	

Table 12 - Manifold Pipe Sizes in Inches - NOTE: The above pipe sizes are based on 20°F Delta and maximum water velocity between 5 - 6 ft/s

CAUTION

When installing a cascaded system, ensure the boilers are the same model. Failure to do so will result in improper system operation, wasted time, money, and possible property damage and personal injury. Such damages ARE NOT covered by product warranty.

G. Pressure Relief Valve

An external pressure relief valve is provided with this boiler. The pressure relief valve MUST BE installed. When installing, observe the following guidelines. The pressure relief valve must be installed as close to the boiler as possible. No other valves should be placed between the pressure relief valve and the boiler. Failure to comply with these guidelines can result in substantial property damage, personal injury, or death.

This boiler has a high-temperature shut-off switch built in as a standard safety feature. Therefore, a "pressure only" relief valve is required. DO NOT operate this boiler before the supplied pressure relief valve is installed with sufficient relieving capacity in accordance with the ASME rating plate on the boiler.

CH Loop

This boiler is provided with a CH pressure relief valve that complies with the ANSI/ASME Boiler and Pressure Vessel Code, Section IV (Heating

Boilers). The included 30 psi CH Pressure Relief Valve must be installed on the CH supply line to ensure a compliant installation and safe operation. HTP has supplied fittings to aid installation of the CH Pressure Relief Valve. The valve is meant to be field installed. **DO NOT** install a CH pipe line relief valve with a pressure rating greater than 30 psi. This is the maximum allowable CH relief valve setting for this boiler.

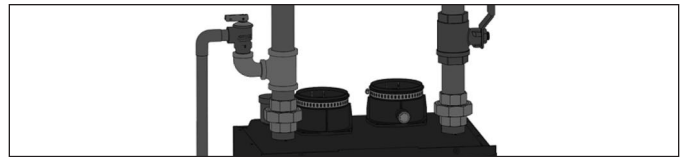

Figure 19 - Pressure Relief Valve

WARNING

To avoid water damage or scalding due to relief valve operation:

- Discharge line must be connected to relief valve outlet and run to a safe place of disposal. Terminate the discharge line in a manner that will prevent possibility of severe burns or property damage should the relief valve discharge.
- Discharge line must be as short as possible and the same size as the valve discharge connection throughout its entire length.
- Discharge line must pitch downward from the valve and terminate at least 6" above the floor drain, making discharge clearly visible.
- Discharge line shall terminate plain, not threaded, with a material serviceable for temperatures of 375°F or greater.
- Do not pipe discharge to any location where freezing could occur.
- No shutoff valve may be installed between the relief valve and boiler or in the discharge line. Do not plug or place any obstruction in the discharge line.
- Test the operation of the relief valve after filling and pressurizing the system by lifting the lever. Make sure the valve discharges freely. If the valve fails to operate correctly, replace it with a new relief valve.
- Test relief valve at least once annually to ensure the waterway is clear. If valve does not operate, turn the boiler "off" **and call a plumber immediately.**
- Take care whenever operating relief valve to avoid scalding injury or property damage.
- For boilers installed with only a pressure relief valve, the separate storage vessel must have a temperature and pressure relief valve installed. This relief valve shall comply with Relief Valves for Hot Water Supply Systems, ANSI Z21.22 CSA4.4.

FAILURE TO COMPLY WITH THE ABOVE GUIDELINES COULD RESULT IN FAILURE OF RELIEF VALVE OPERATION, RESULTING IN POSSIBILITY OF SUBSTANTIAL PROPERTY DAMAGE, SEVERE PERSONAL INJURY, OR DEATH.

Do not thread a cap or plug into the relief valve or relief valve line under any circumstances! Explosion and property damage, serious injury, or death may result.

WARNING

RE-INSPECTION OF RELIEF VALVES: Valves should be inspected AT LEAST ONCE EVERY THREE YEARS, and replaced if necessary, by a licensed plumbing contractor or qualified service technician to ensure that the product has not been affected by corrosive water conditions and to ensure that the valve and discharge line have not been altered or tampered with illegally. Certain naturally occurring conditions may corrode the valve and its components over time, rendering the valve inoperative. Such conditions can only be detected if the valve and its components are physically removed and inspected. **Do not attempt to conduct an inspection on your own.** Contact your plumbing contractor for a re-inspection to assure continued safety.

FAILURE TO RE-INSPECT THE RELIEF VALVE AS DIRECTED COULD RESULT IN UNSAFE TEMPERATURE AND/OR PRESSURE BUILD-UP WHICH CAN RESULT IN PROPERTY DAMAGE, SERIOUS PERSONAL INJURY, OR DEATH.

H. Built-In Low Water Cut-Off (LWCO)

NOTE: This boiler is equipped with a low water cut-off (LWCO) probe. When this LWCO senses low water level, boiler operation will cease and Er:80 will appear on the display panel. Er:80 will clear and boiler operation will resume when the low water condition is remedied. Local codes or jurisdictions may accept this control function as a means of providing low water protection.

I. Optional External UL353 Manual Reset Low Water Cut-Off (LWCO) Interface Kit

HTP offers an optional External UL 353 Manual Reset Low Water Cut-Off (LWCO) Interface Kit if a UL 353 LWCO is required by local codes. The LWCO should be mounted into a tee as detailed in Figure 20. It should then be wired into the boiler as described in Figure 21. Remove the jumper from the LWCO relay connection when installing.

Follow the complete instructions included in the kit for proper installation.

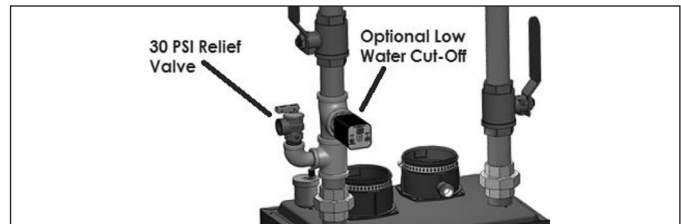

Figure 20 - Optional LWCO Installation Details

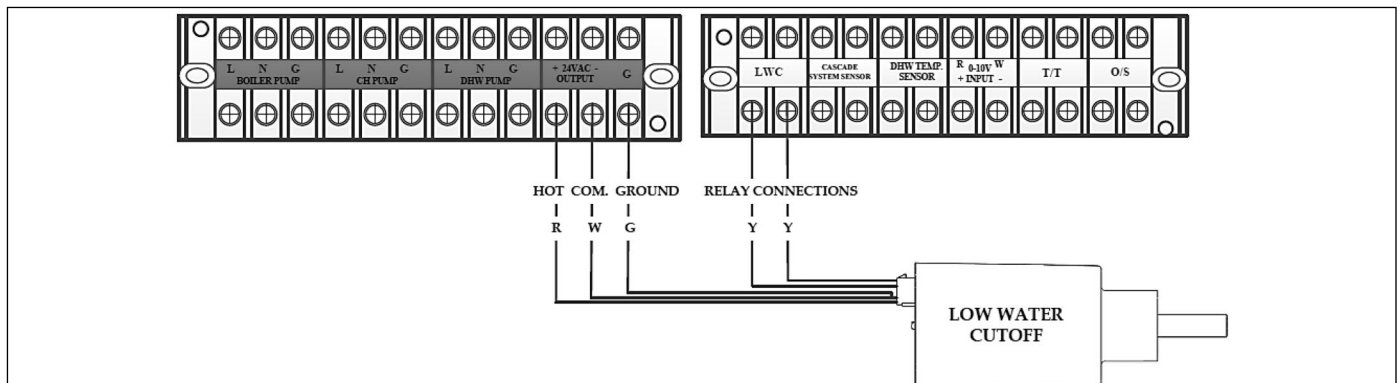

Figure 21 - Wiring External Optional LWCO to the Boiler

Part 5 - Venting

⚠ DANGER

The boiler must be vented as detailed in this section. Ensure exhaust vent and intake piping complies with these instructions regarding vent system. Inspect finished exhaust vent and intake piping thoroughly to ensure all joints are well secured, airtight, and comply with all applicable code requirements, as well as the instructions provided in this manual. Failure to properly install the vent system will result in severe personal injury or death.

A. General

⚠ DANGER

This boiler is certified as a "Category IV" appliance and requires a special venting system. The vent system will operate with a positive pressure in the pipe. Exhaust gases must be piped directly outdoors using the vent materials and rules outlined in these instructions. Do not connect vent connectors serving appliances vented by natural draft into any portion of mechanical draft systems operating under positive pressure. Follow the venting instructions carefully. Failure to do so will result in substantial property damage, severe personal injury, or death.

Exhaust and intake are to be piped separately. This boiler cannot share a common exhaust or intake with multiple appliances. Failure to follow these instructions will result in substantial property damage, severe personal injury, or death.

1. Installation should be made in accordance with the regulations of the Authority Having Jurisdiction, local code authorities, and utility companies which pertain to this type of water heating equipment.
2. Install the venting system in accordance with these instructions and with the National Fuel Gas Code, ANSI Z223.1/NFPA 54, CAN/CGA B149, and / or applicable provisions of local building codes.
3. This boiler must be vented with materials, components, and systems listed and approved for Category IV appliances.

NOTE: To avoid contamination often contained in indoor air, it is best to pipe all intake combustion air directly to the outdoors.

NOTE: Care must be taken to prevent condensate freezing in the exhaust vent pipe system. See local, state, provincial, and national codes for best practices to prevent condensate freezing in the exhaust vent pipe system.

⚠ WARNING

Improper seating of vent pipe gaskets can cause eventual gasket failure and exhaust gas leakage. Ensure the exhaust vent pipe is properly beveled and seated before insertion into the flue adapter. Failure to do so could result in property damage, severe personal injury, or death.

⚠ DANGER

Due to the extreme flammability of most glues, cements, solvents, and primers used to join plastic exhaust vent and intake pipes, explosive solvent vapors must be cleared from all vent piping before start-up. Avoid using excess cement or primer, as this may pool in the vent pipes. Vent assemblies should be allowed to cure for a period of at least 8 hours before powering a connected appliance. Failure to follow these instructions will result in substantial property damage, severe personal injury, or death. It is the installers' responsibility to understand the hazards associated with explosive solvents and take the necessary precautions to avoid these risks.

⚠ WARNING

Breathing Hazard - Carbon Monoxide Gas



- Do not operate heater if flood damaged.
- Install vent system in accordance with local codes and manufacturers installation instructions.
- Do not obstruct heater air intake or exhaust. Support all vent piping per manufacturers installation instructions.
- Do not place chemical vapor emitting products near unit.
- According to NFPA 720, carbon monoxide detectors should be installed outside each sleeping area.
- Never operate the heater unless it is vented to the outdoors.
- Analyze the entire vent system to make sure that condensate will not become trapped in a section of vent pipe and therefore reduce the open cross sectional area of the vent.

Breathing carbon monoxide can cause brain damage or death. Always read and understand instruction manual.

LP-304

⚠ WARNING

- DO NOT insulate the first three (3) linear feet of the exhaust vent run.
- CPVC, Polypropylene, or Stainless Steel pipe material MUST be used if the first three (3) linear feet of the exhaust vent run is insulated or passes through an enclosed space greater than 6" in length, such as a wall. **NOTE:** Only Stainless Steel pipe material may be insulated.
- If CPVC is used to meet these requirements, the balance may be installed with approved PVC pipe.
- If Polypropylene or Stainless Steel is used to meet these requirements, the balance of the vent run must be installed with the same material.
- Failure to comply with this warning could result in property damage, severe personal injury, or death.

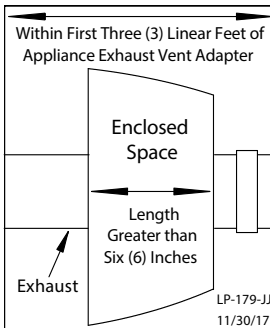

LP-179-JJ
11/30/17

Exhaust vent adaptors are not designed as load-bearing devices, and must not be used to support exhaust vent piping. All vent pipes must be properly connected, supported, and the exhaust vent must be pitched a minimum of 1/4" per foot back to the boiler to allow drainage of condensate. Failure to properly support vent piping and follow the information in this statement could result in product damage, severe personal injury, or death.

CAUTION

High heat sources (generating heat 100°F / 37°C or greater, such as boiler flue pipes, space heaters, etc.) may damage plastic components of the boiler as well as plastic vent pipe materials. Such damages ARE NOT covered by warranty. It is recommended to keep a minimum clearance of 8" from high heat sources. Observe heat source manufacturer instructions, as well as local, state, provincial, and national codes, laws, regulations, and ordinances when installing this boiler and related components near high heat sources.

B. Approved Materials for Exhaust Vent and Intake Pipe

Item	Material	Standards for Installation In:	
		United States	Canada
Pipe and Fittings Approved for Intake ONLY	ABS*	ANSI/ASTM D2661	NOT PERMITTED
Pipe Approved for Intake OR Exhaust Vent	PVC Schedule 40/80	ANSI/ASTM D1785	PVC, CPVC, and PP Venting Must be ULC-S636 Certified. IPEX is an approved manufacturer in Canada.
	PVC-DWV Schedule 40/80	ANSI/ASTM D2665	
	CPVC Schedule 40/80	ANSI/ASTM F441	
	Polypropylene	UL-1738 or ULC-S636	
	Stainless Steel AL29-4C	Certified for Category IV and Direct Vent Appliance Venting	
Pipe Fittings	PVC Schedule 40	ANSI/ASTM D2466 or D2665	PVC, CPVC, and PP Venting Must be ULC-S636 Certified. IPEX is an approved manufacturer in Canada.
	PVC Schedule 80	ANSI/ASTM D2467 or D2665	
	CPVC Schedule 40	ANSI/ASTM F438	
	CPVC Schedule 80	ANSI/ASTM F439	
Pipe Cement	ABS*	ANSI/ASTM D2235	NOT PERMITTED
	PVC	ANSI/ASTM D2564	IPEX System 636 Cements and Primers
	CPVC	ANSI/ASTM F493	
Pipe Primer	PVC / CPVC	ASTM F656	

DANGER

- The exhaust and intake components installed with this appliance must be used for near appliance piping BEFORE transitioning to the approved materials listed above. DO NOT REMOVE these installed components. Doing so WILL VOID appliance warranty.
- PVC / CPVC pipe and fittings of the same diameter are considered interchangeable.
- The use of cellular core PVC (ASTM F891), cellular core CPVC, or Radel® (polyphenolsulfone) in non-metallic venting systems is prohibited.
- Covering non-metallic vent pipe and fittings with thermal insulation is prohibited.
- DO NOT connect PVC/CPVC to Polypropylene without an approved vent connector.
- Any transition to Polypropylene MUST be done in the vertical within five (5) feet of the appliance.
- When installing AL29-4C vent piping, install a PVC-to-stainless adapter at the appliance vent connection, and at the termination when using a PVC termination kit. DO NOT mix AL29-4C piping from different manufacturers unless using adapters specifically designed for the purpose by the manufacturer.
- A double wall vent or insulated material may be used when using stainless steel vent material in a freezing climate.
- *ABS may be used for air intake applications ONLY. ABS is NOT PERMITTED for use in Canada.
- Contact the venting material manufacturer if there is any question about the applicability of the proposed venting material.

Failure to follow these directions will result in substantial property damage, severe personal injury, or death.

Table 13 - Approved Materials for Exhaust Vent and Intake Pipe

WARNING
DO NOT mix components from different venting systems. The vent system could fail, causing leakage of flue products into the living space. Use only the approved pipe and fitting materials, and primer and cement specifically designed for the material used, as listed in the above table. Failure to do so could result in property damage, serious injury, or death.
It is required to insert the provided exhaust and intake screens into the vent terminations to prevent blockage caused by debris or birds. Failure to keep terminations clear could result in property damage, severe personal injury, or death.

NOTE: The use of double-wall vent or insulated material for the combustion air intake pipe is recommended in cold climates to prevent the condensation of airborne moisture in the incoming combustion air.

DANGER
You must not use "B" vent in an exhaust application. "B" vent is for intake applications ONLY. Using "B" vent in an exhaust application will result in serious injury or death.

C. Additional Requirements for Installation in Canada

- Installations must be made with a vent pipe system certified to ULC-S636. IPEX is an approved vent manufacturer in Canada supplying vent material listed to ULC-S636. Additionally, you may use AL29-4C stainless steel venting to comply with Canadian requirements.
- The first three (3) feet of vent pipe from the boiler flue outlet must be readily accessible for visual inspection.
- The components of the certified vent system must not be interchanged with other vent systems or unlisted pipe / fittings.

D. Exhaust Vent and Intake Pipe Location

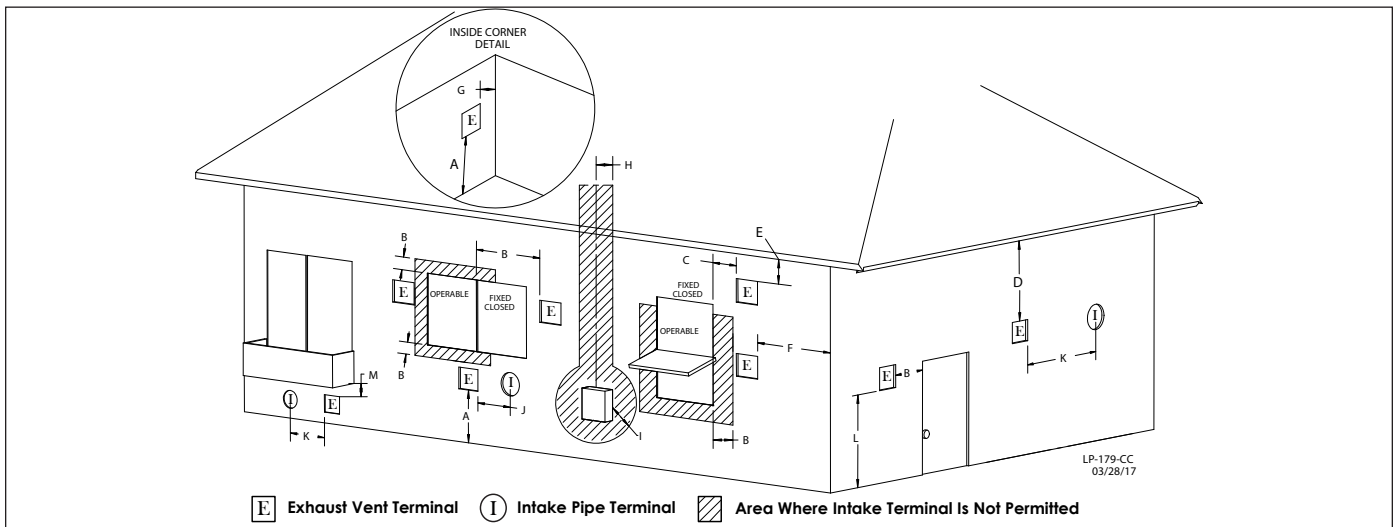

Figure 22 - Exit Terminals for Direct Vent Systems - ANSI Z223.1 / NFPA 54 for US and CAN/CSA B149.1 for Canada

DESCRIPTION		US	CANADA
A	Clearance above grade, veranda, porch, deck, or balcony	1 foot (30 cm)	
B	Clearance to window or door that may be opened	Direct Vent	3 feet (91 cm)
		Power Vent	
C	Clearance to permanently closed window	*	
D	Vertical clearance to ventilated soffit located above the terminal within a horizontal distance 2 feet (61 cm) from the center line of the terminal	*	
E	Clearance to unventilated soffit	*	
F	Clearance to outside corner	*	
G	Clearance to inside corner	*	
H	Clearance to each side of center line extended above meter / regulator assembly	*	
I	Clearance to service regulator vent outlet	*	Above a regulator within 3 feet (91 cm) horizontally of the vertical center line of the regulator vent outlet to a maximum vertical distance of 15 ft (4.5 m)
J	Clearance to nonmechanical air supply inlet to building or the combustion air inlet to any other appliance	Direct Vent	3 feet (91 cm)
		Power Vent	
K	Clearance to mechanical air supply inlet	3 feet above if within 10 feet horizontally	6 feet (1.83 m)
L	Clearance above paved sidewalk or paved driveway located on public property	Direct Vent	7 feet (2.13 m)
		Power Vent	
M	Clearance under veranda, porch deck, or balcony	*	

Table 14 - Vent Termination Clearances - *NOTE: For clearances not specified in ANSI Z223.1 / NFPA 54 for US and CAN/CSA B149.1 for Canada, please use clearances in accordance with local installation codes and the requirements of the gas supplier.

⚠ WARNING

The building owner is responsible for keeping the exhaust and intake terminations free of snow, ice, or other potential blockages, as well as scheduling routing maintenance. Failure to keep the vent piping terminations clear and properly maintain the boiler could result in property damage, severe personal injury, or death.

For each floor containing bedroom(s), a carbon monoxide detector and alarm shall be placed in the living area outside the bedrooms, as well as in the room that houses the boiler. Detectors and alarms shall comply with NFPA 720 (latest edition). Failure to comply with these requirements could result in product damage, severe personal injury, or death.

E. Exhaust Vent and Intake Pipe Sizing

- The exhaust vent and intake pipe size is 3".
- The total equivalent length of 2" exhaust vent and intake pipe **should not exceed fifty (50) feet**; 3" exhaust vent and intake pipe **should not exceed one hundred (100) feet**.

a. The equivalent length of elbows, tees, and other fittings are listed in the Friction Loss Table.

b. For example: If the exhaust vent has two 90° elbows and 10 feet of PVC pipe we will calculate:

Exhaust Vent Equivalent Length = $(2 \times 5) + 10 = 20$ feet.

Further, if the intake pipe has two 90° elbows, one 45° elbow, and 10 feet of PVC pipe, the following calculation applies:

Intake Pipe Equivalent Length = $(2 \times 5) + 3 + 10 = 23$ feet.

Finally, if a concentric kit is used we find:

Total Equivalent Length = $20 + 23 + 3 = 46$ feet.

The total equivalent length is 46 feet, well below the maximum of 100 feet.

c. Effort should be made to keep a minimum difference in equivalent length between the exhaust vent and intake pipe.

Friction Loss Equivalent in Piping and Fittings		
Fittings or Piping	Equivalent Feet	
	2"	3"
90 Degree Elbow*	5'	5'
45 Degree Elbow	3'	3'
Coupling	0'	0'
Air Inlet Tee	0'	0'
Straight Pipe	1'	1'
Concentric Kit	3'	3'
V500 2" Kit	1'	N/A
V1000 3" Kit	N/A	1'
V2000 4" Kit	N/A	1'

Table 15 - *Friction loss for long radius elbow is 1 foot less. NOTE: Consult Polypropylene venting instructions for friction loss and pressure drop equivalents.

3. The minimum total equivalent length is 14 feet.

NOTE: The intake pipe and exhaust vent lengths do not have to be of equal length. There is no balancing requirement between intake and exhaust.

2" Combined Vent Length		3" Combined Vent Length	
Minimum	Maximum	Minimum	Maximum
14' (4.2M)	50' (50M)	14' (4.2M)	100' (30M)
Maximum # of 90° Elbows (2" and 3" Vent Diameters)			
6			

Table 16 - Approved Vent Lengths

CAUTION
Do not exceed the maximum lengths for vent pipes. Excessive length could result in boiler shutdown and property damage.
Failure to provide a minimum total vent length of 14 equivalent feet could result in property damage and improper product operation.

F. Tightening Boiler Collar to Exhaust Vent and Intake Pipe

This appliance uses 2" or 3" diameter pipe for exhaust vent and intake pipe. In order to use 2" pipe, it is required to reduce pipe size in a vertical length of pipe with a 3" x 2" reducing coupling (not included). Follow the steps below to install 3" vent pipe into the appliance vent collar. See Figure 23 for additional details.

NOTE: Clean and dry the appliance connection. DO NOT use primer or cement on the appliance connection.

- Push the length of pipe into the connection until it touches the bottom of the fitting.
- Tighten the clamps using a screwdriver.
- Ensure the pipe is secure before continuing installation.
- For 2" installations, install the reducing coupling in a vertical section of pipe. At least a 6" length of 3" pipe **MUST BE INSTALLED** before reducing to 2". See Figure 24.

NOTE: A reducing coupling **MUST BE USED** when transitioning from 3" to 2" vent pipe. DO NOT use reducing bushings.

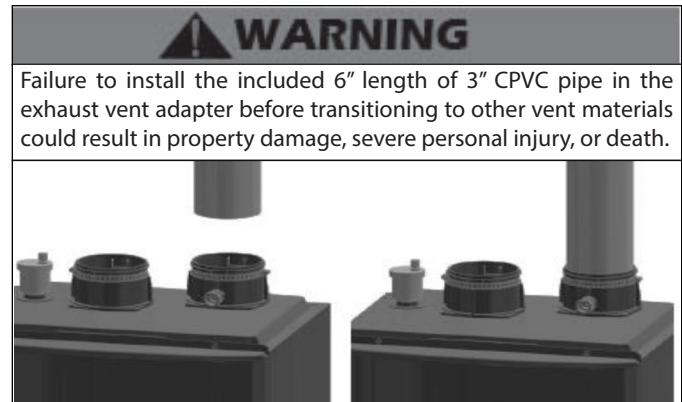

Figure 23 - Correct Installation into the Appliance Collar

NOTE: REDUCING VENT SIZE: TRANSITIONING FROM 3" TO 2" VENT PIPE MUST ALWAYS TAKE PLACE IN A VERTICAL POSITION TO PREVENT CONDENSATE BLOCKAGE

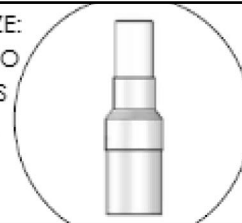

Figure 24 - Transitioning from 3" to 2" Vent Pipe

G. Exhaust Vent and Intake Pipe Installation

WARNING
All joints of positive pressure vent systems must be sealed completely to prevent leakage of flue products into the living space. Failure to do so could result in property damage, serious injury, or death.

- Use only solid PVC, CPVC, or stainless steel pipe or a Polypropylene vent system approved for use with Category IV appliances. ABS pipe material may be used on air inlet piping **only**.
- Remove all burrs and debris from joints and fittings.
- When using PVC or CPVC pipe, all joints must be properly cleaned, primed, and cemented. Use only cement and primer approved for use with the pipe material. Cement must conform to ASTM D2564 for PVC and ASTM F493 for CPVC pipe. **NOTE: DO NOT CEMENT POLYPROPYLENE PIPE.**
- Ensure the vent is located where it will not be exposed to prevailing winds.
- In all roof venting applications, exhaust discharge must point away from the pitch of the roof.
- To prevent water leakage, install adequate roof flashing where the pipe enters the roof.
- Do not locate vent over public walkways, driveways, or parking lots. Condensate could drip and freeze, resulting in a slip hazard or damage to vehicles and machinery.
- Due to potential moisture build-up, sidewall venting may not be the preferred venting option. To save time and cost, carefully consider venting installation and location.
- Horizontal lengths of exhaust vent must slope back towards the boiler not less than 1/4" per foot to allow condensate to drain from

the vent pipe.

10. The exhaust vent must terminate where vapors cannot make accidental contact with people or pets, or damage shrubs or plants.
11. In vacant chimney applications, install and seal a rain cap over existing chimney openings.
12. All piping must be fully supported. Use pipe hangers at a minimum of 4 foot intervals to prevent sagging of the pipe where condensate may form.
13. Do not use the boiler to support any piping.
14. A screened straight coupling is provided with the boiler for use as an outside exhaust termination.
15. A screened inlet air tee is provided with the boiler to be used as an outside intake termination.
16. Maximum Snow Level Determination: These installation instructions reference snow levels in establishing a minimum height for the installation of exhaust vent or air intake terminations. Snow levels shall be determined as follows:
 - a. The installation location may, by ordinance, designate how snow levels are calculated in that location; or
 - b. In the absence of specific ordinances, snow levels shall be calculated from the average monthly maximum depth of snow accumulation as indicated by the National Weather Service’s 10 year statistics for the installation location/geographical area.

In addition:

- Total length of vent piping shall not exceed the limits specified in this manual.
- The vent piping for this direct vented appliance is approved for zero clearance to combustible construction.
- The flue products coming from the exhaust vent will create a large plume when the boiler is in operation. Avoid venting in areas that will affect neighboring buildings or be considered objectionable.
- DO NOT locate exhaust vent or intake pipe in a parking area where machinery may damage the pipe.
- DO NOT vent near soffit vents, crawl space vents, or other areas where condensate or vapor could create a nuisance or hazard or cause property damage.
- DO NOT vent where condensate vapor could cause damage or could be detrimental to the operation of regulators, relief valve, or other equipment.

In the Commonwealth of Massachusetts and as Required by State and Local Codes:

- The vented gas fueled appliance shall not be installed so its combustion, ventilation, or dilution air is obtained from a bedroom or bathroom.
- Signage: Whenever any through-the-wall (horizontal or sidewall) vent is installed less than seven feet above the finished grade, a metal or plastic identification plate shall be permanently mounted to the exterior of the building at a minimum height of eight feet above grade directly in line with the exhaust vent terminal. The sign shall read, in print no less than 0.5 inches in size, "GAS VENT DIRECTLY BELOW. KEEP CLEAR OF ALL OBSTRUCTIONS".
- Marking of Exhaust Vent and Intake Pipe: Piping used for ventilation, make-up, or combustion air intake shall be labeled as follows:
 - a. Throughout the entire developed length:
 - i. Labels must be placed every ten feet for exposed/visible piping; or
 - ii. Labels must be placed every three feet for concealed piping.
 - b. At all changes of direction;
 - c. On each side of a penetration through a partition, wall or ceiling; and
 - d. The labels shall be black lettering that:
 - i. Indicates that the piping is used for ventilation, make-up,

or combustion air intake, and

- ii. The letters shall be sized equal to a minimum of the pipe diameter. However, for piping with a diameter exceeding two inches, said lettering does not need to be larger than two inches.

This table lists optional exhaust/intake terminations available from HTP:

Description	Stock Code
2" PVC Concentric Termination Kit	KGAVT0501CVT
3" PVC Concentric Termination Kit	KGAVT0601CVT
2" Stainless Steel Termination Kit	V500
3" Stainless Steel Termination Kit	V1000
3" Polypro Vent Kit	8400P-001

Table 17 - Optional Vent Kits

H. Applications

1. Direct Vent Installation of Exhaust and Intake

If installing a direct vent option, combustion air must be drawn from the outdoors directly into the boiler intake, and exhaust must terminate outside. There are three basic direct vent options detailed in this manual: 1. Side Wall Venting, 2. Roof Venting, and 3. Unbalanced Venting.

Be sure to locate the boiler such that the exhaust vent and intake pipe can be routed through the building and properly terminated. Different vent terminals can be used to simplify and eliminate multiple penetrations in the building structure (see Optional Equipment in Venting Section). The exhaust vent and intake pipe lengths, routing and termination methods must all comply with the methods and limits given in the Venting section of this manual.

When installing a combustion air intake from outdoors, care must be taken to utilize uncontaminated combustion air. **NOTE:** To prevent combustion air contamination, see Table 6.

 WARNING
All vent pipes must be glued, properly supported, and the exhaust pitched a minimum of 1/4" per foot back to the boiler to allow drainage of condensate. When placing support brackets on vent piping, the first bracket must be within 1 foot of the boiler and the balance of 4 foot intervals on the vent pipe. Venting must be readily accessible for visual inspection from the first three feet from the boiler.
Take extra precaution to adequately support the weight of vent pipes terminating through the roof. Failure to properly support roof terminated piping could result in property damage, serious injury, or death.

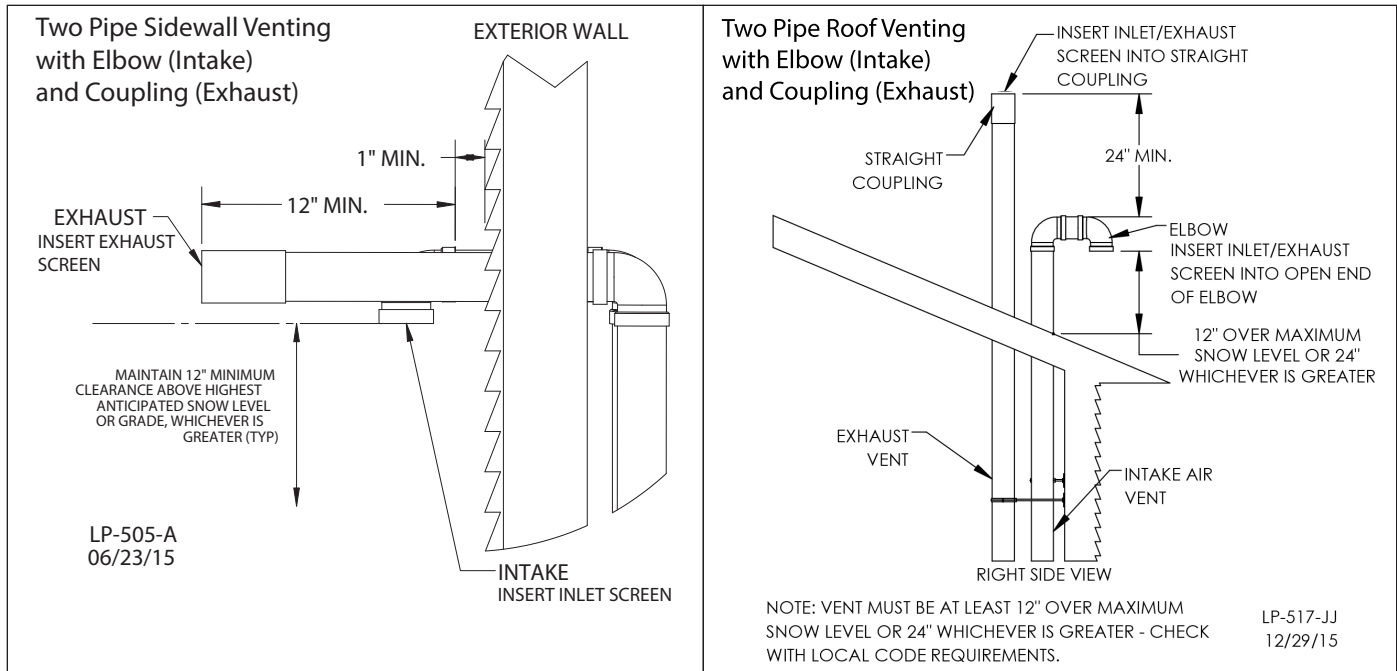

Figure 25 - Direct Vent, Roof and Sidewall Vent Terminations

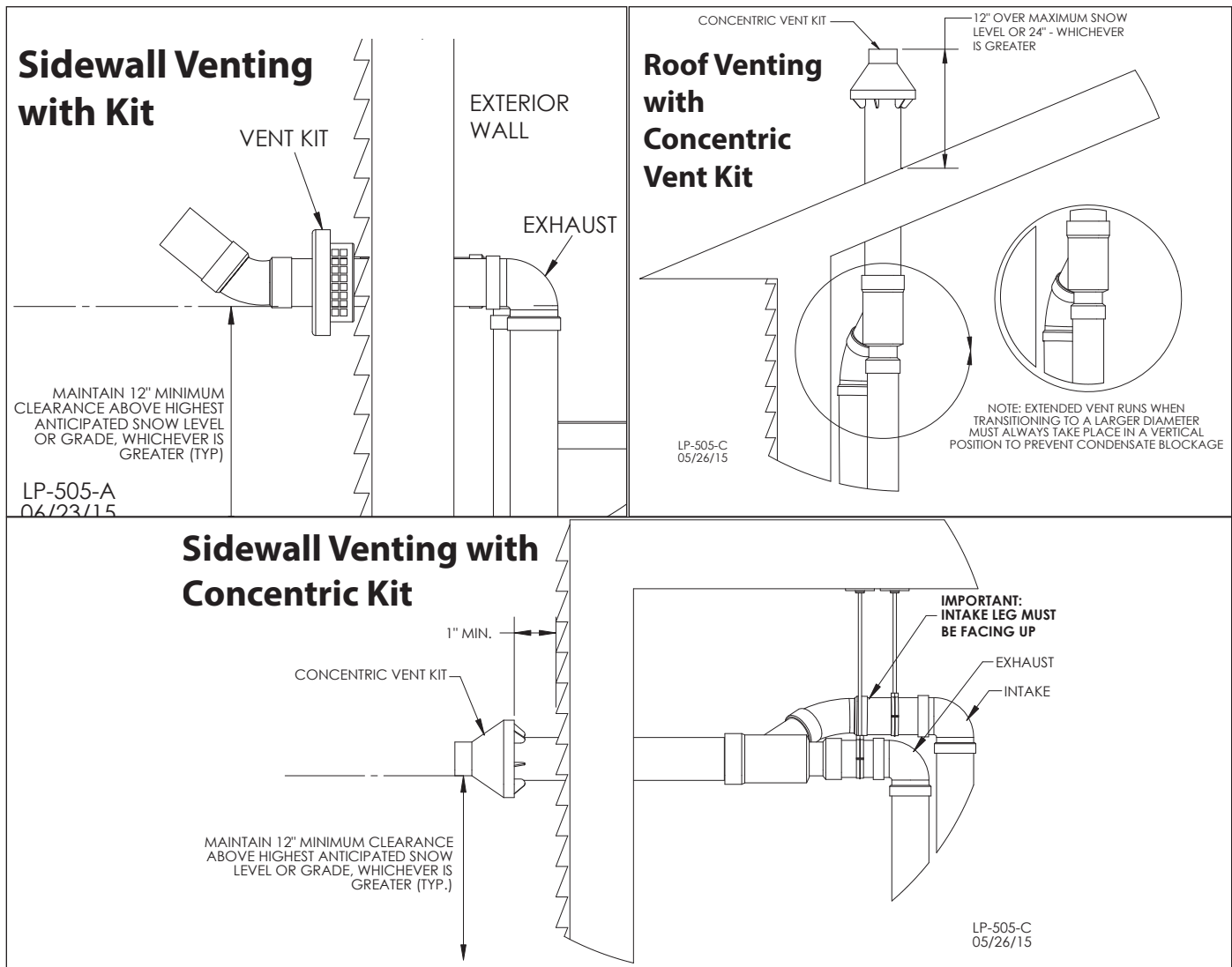

Figure 26 - Direct Vent, Vent Terminations with Optional Kits (NOT INCLUDED WITH THE APPLIANCE)

NOTE: These drawings are meant to demonstrate system venting only. The installer is responsible for all equipment and detailing required by local codes.

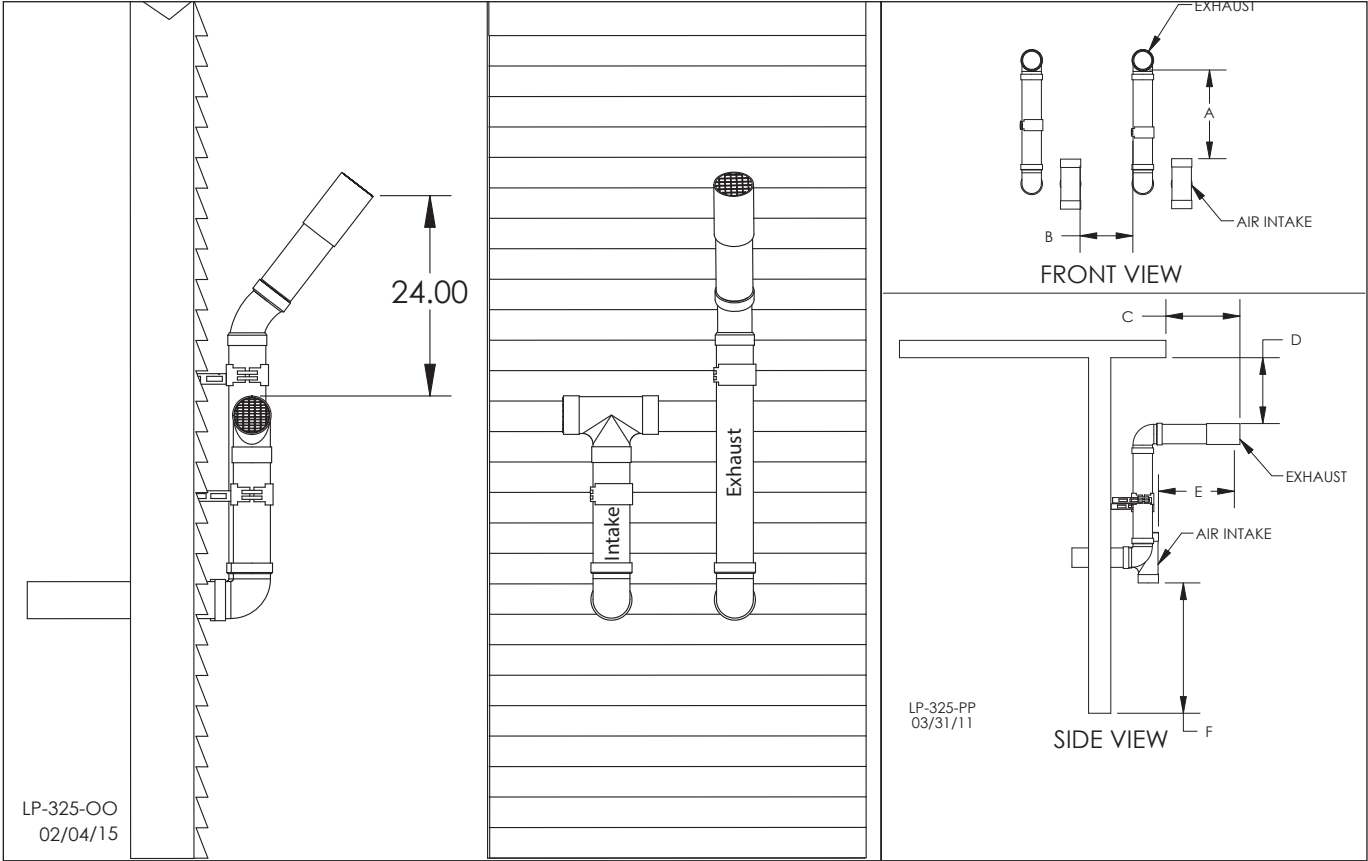

Figure 27 - Horizontal (Snorkel) Venting

NOTES:

- A. For every 1" of overhang, the exhaust vent must be located 1" vertical below overhang (overhang means top of building structure and not two adjacent walls [corner of building]).
- B. Typical installations require 12" minimum separation between bottom of exhaust outlet and top of air intake.
- C. Maintain 12" minimum clearance above highest anticipated snow level or grade (whichever is greater).
- D. Minimum 12" between vents when installing multiple vents.
- E. 12" minimum beyond air intake.

Screen Installation

After connecting the intake air and exhaust vent pipes, it is required to install the included screens into the exhaust vent and intake pipe terminations to prevent damages to the unit due to blockages. See Figure 28 for installation detail.

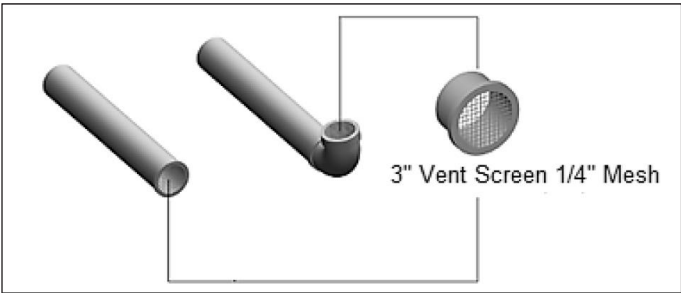

Figure 28 - Screen Installation - NOTE: Vent termination elbow is meant to be installed open end facing the ground. Orientation in Figure 28 is meant to demonstrate proper Vent Screen installation ONLY.

2. Venting Through an Existing System

This boiler may be vented through an existing unused vent system. The inner diameter of the existing vent system is utilized for the combustion air source. Two methods have been approved for such venting: Concentric Venting Through an Existing System and Venting as a Chase.

Concentric venting through an existing system must run vertically through the roof. See Table 18 for proper minimum vent sizing. Use only the approved venting materials specified in Table 13 for piping the system. All instructions listed in this Venting section apply. See Figures 29-1 and 29-2 for venting demonstrations.

⚠ DANGER

Do not install the boiler into a common existing vent with any other appliance. This will cause flue gas spillage or boiler malfunction, resulting in substantial property damage, serious personal injury, or death.

CAUTION

Contractors must check state and local codes before installing through an existing vent opening. State and local codes always take precedence over manufacturer's instructions. Failure to check state and local codes before installing through an existing opening could result in property damage and add significantly to installation costs.

If an existing venting system is converted for use with this boiler, the installer must ensure that the existing venting system is clean and free from particulate contamination that could damage the boiler. Failure to do so could result in property damage and boiler failure. Such failure IS NOT covered under warranty.

Vent / Air Inlet Size	Minimum Existing Vent / Chase Size
2"	4"
3"	5"
4"	7"

Table 18 - Minimum Existing Vent / Chase Sizing

⚠ DANGER

The upper and lower vent terminations as well as all joints in the venting system must be properly sealed to ensure that all combustion air is drawn properly and exhaust does not leak from the system. Failure to properly seal the venting system will result in property damage, serious personal injury, or death.

Chase Venting Through an Existing System

When venting as a chase, follow all instructions included in this Venting section, including those in the previous Concentric Venting Through an Existing System section. See Figure 29-3 for chase venting demonstration.

Concentric Venting Through an Existing System

NOTE: The following instructions refer only to venting through an existing vent system, and not to venting with HTP's optional concentric vent kits. Refer to Concentric Vent Kit installation manual (LP-166) for further information on venting with the optional concentric vent kits.

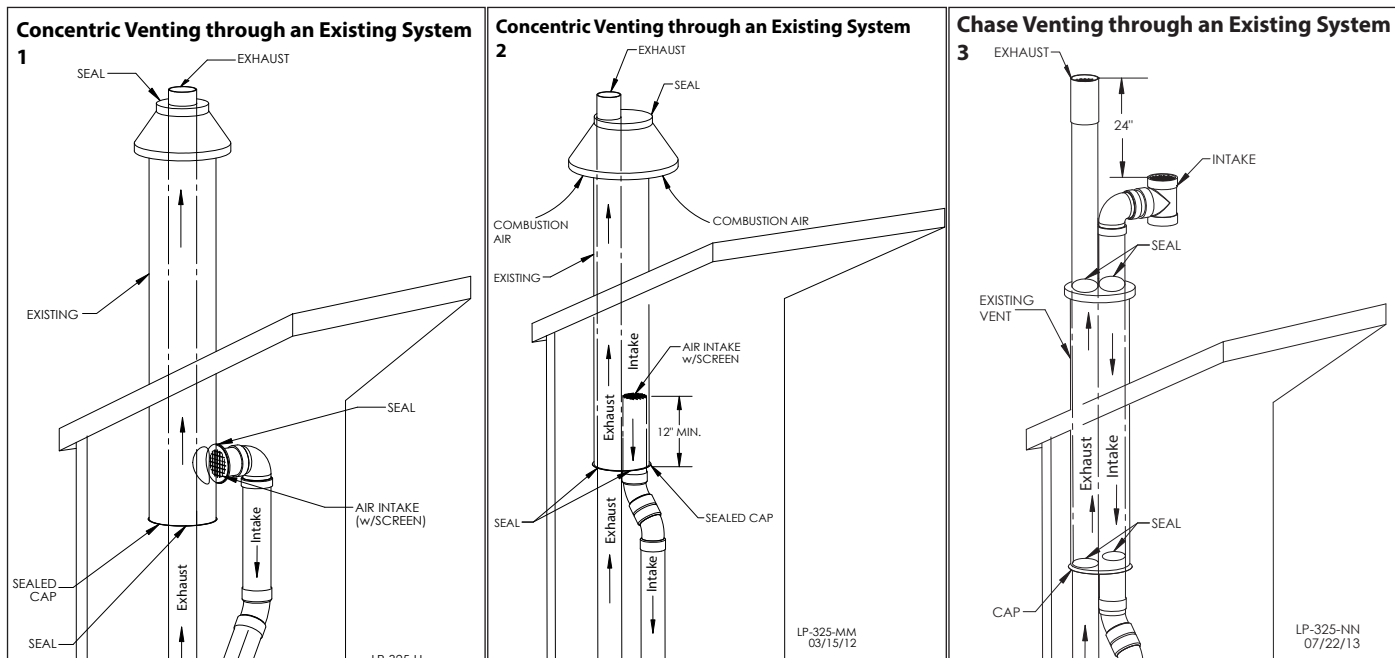

Figure 29 - 1, 2 - Concentric Venting Through an Existing System, 3, Chase Venting Through an Existing System

NOTE: These drawings are meant to demonstrate system venting only. The installer is responsible for all equipment and detailing required by local codes.

3. Power Venting, Indoor Combustion Air in Confined or Unconfined Space

This boiler requires fresh, uncontaminated air for safe operation and must be installed in a mechanical room where there is adequate combustion and ventilating air. **NOTE: To prevent combustion air contamination, see Table 6.**

Combustion air from the indoor space can be used if the space has adequate area or when air is provided through a duct or louver to supply sufficient combustion air based on the boiler input. **Never obstruct the supply of combustion air to the boiler.** If the boiler is installed in areas where indoor air is contaminated (see Figure 30) it is imperative that the boiler be installed as direct vent so that all combustion air is taken directly from the outdoors into the boiler intake connection.

Unconfined space is space with volume greater than 50 cubic feet per 1,000 Btu/hour (4.8 cubic meters per kW) of the total input rating of all fuel-burning appliances installed in that space. Rooms connected directly to this space, through openings not furnished with doors, are

considered part of the space.

Confined space is space with volume less than 50 cubic feet per 1,000 Btu/hour (4.8 cubic meters per kW) of the total input rating of all fuel-burning appliances installed in that space. Rooms connected directly to this space, through openings not furnished with doors, are considered part of the space.

When drawing combustion air from inside a conventionally constructed building to a confined space, such space should be provided with two permanent openings: one located 6" (15 cm) below the space ceiling, the other 6" (15cm) above the space floor. Each opening should have a free area of one square inch per 1,000 Btu/hr (22cm²/kW) of the total input of all appliances in the space, but not less than 100 square inches (645cm²).

If the confined space is within a building of tight construction, air for combustion must be obtained from the outdoors as outlined in the Venting section of this manual. See Figure 31.

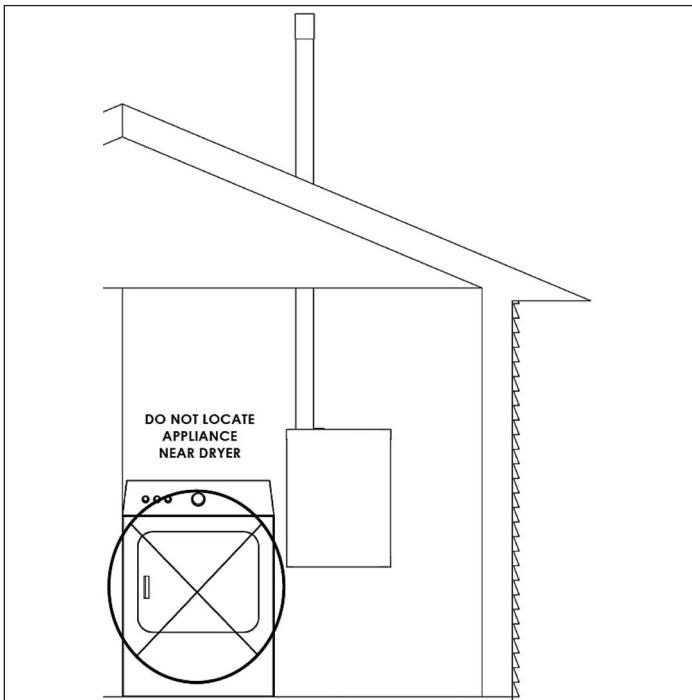



Figure 30 - Do Not Place Appliance Near Dryer

⚠ WARNING

Breathing Hazard - Carbon Monoxide Gas



- Do not operate heater if flood damaged.
- Install vent system in accordance with local codes and manufacturers installation instructions.
- Do not obstruct heater air intake or exhaust. Support all vent piping per manufacturers installation instructions.
- Do not place chemical vapor emitting products near unit.
- According to NFPA 720, carbon monoxide detectors should be installed outside each sleeping area.
- Never operate the heater unless it is vented to the outdoors.
- Analyze the entire vent system to make sure that condensate will not become trapped in a section of vent pipe and therefore reduce the open cross sectional area of the vent.

Breathing carbon monoxide can cause brain damage or death. Always read and understand instruction manual.

LP-304

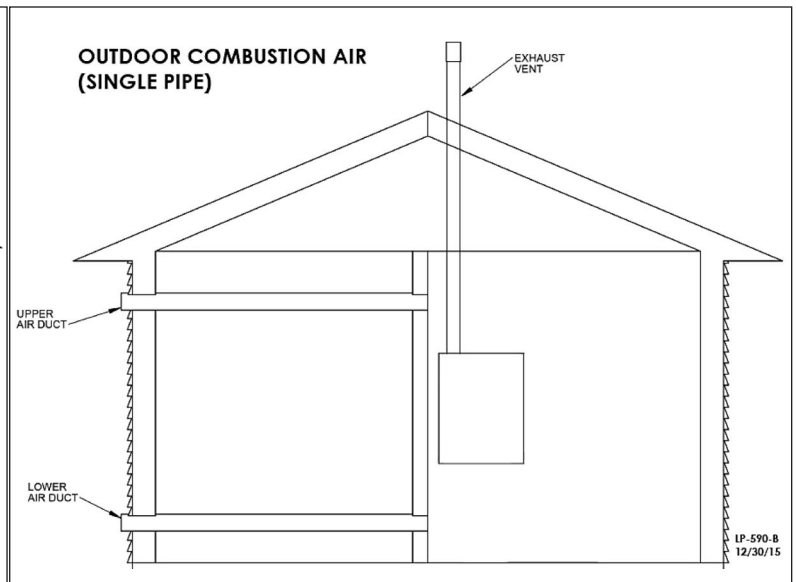
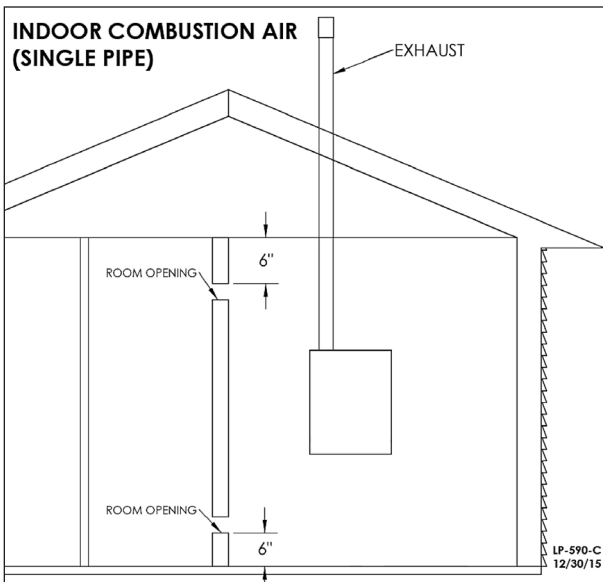

Figure 31 - Power Venting, Indoor and Outdoor Combustion Air - Single Pipe

NOTE: These drawings are meant to demonstrate system venting only. The installer is responsible for all equipment and detailing required by local codes.

Part 6 - Installing the Condensate Drain

CAUTION

This condensing high efficiency boiler has a condensate removal system. Condensate is water vapor derived from combustion products, similar to that produced by an automobile when it is initially started. It is very important that the condensate line is sloped down away from the boiler and to a suitable drain.

The condensate line must remain unobstructed. If allowed to freeze in the line or obstructed in any other manner, condensate can exit from the boiler tee, resulting in potential water damage to property. When installing a condensate pump, select one approved for use with condensing boilers and furnaces. The condensate pump should have an overflow switch to prevent property damage from spillage. Condensate from the boiler will be slightly acidic (pH from 3.2 to 4.5). Check with your local gas company to determine if combustion condensate disposal is permitted in your area. Install a neutralizing filter if required by local codes.

NOTES:

1. Due to its efficient design, the boiler produces condensate (water) as a normal by-product. This condensate is acidic, with a pH level between 3 and 4. This condensate must be drained away from the boiler and disposed in accordance with all local regulations.
2. Condensate line must be pitched at least $\frac{1}{4}$ " per foot to properly drain. If this cannot be done, or a very long length of condensate hose is used, increase the condensate line to a minimum of 1" ID and place a tee in the line after the condensate neutralizer to properly reduce vacuum lock in the drain line.
3. Use corrosion-resistant materials to drain condensate. Use the included flexible plastic hose or $\frac{1}{2}$ " PVC and CPVC drain pipe complying with ASTM D1785, F441, or D2665 may be used. Cement must comply with ASTM D2564 for PVC pipe or F493 for CPVC pipe. For Canadian applications, use CSA or ULC certified PVC or CPVC pipe, fittings, and cement.
4. A frozen condensate line could result in a blocked vent condition. It is very important to protect the condensate line from freezing temperatures or any type of blockage. In installations that may encounter sustained freezing conditions, the use of heat tape is recommended to avoid freezing of the condensate line. It is also recommended to bush up the condensate line size to 1" and terminate condensate discharge as close to the unit as possible. Longer condensate runs are more

prone to freezing. Damages due to frozen or blocked condensate lines ARE NOT covered by warranty.

5. Support of the condensate line may be necessary to avoid blockage of the condensate flow.
6. Local building codes may require an in-line neutralizer (1) to be installed (not included) to treat the condensate. If required by local authorities, a condensate filter of lime crystals, marble, or phosphate chips will neutralize slightly acidic condensate (p/n 7450P-212 available from HTP). Follow all the installation instructions included with the neutralizer. If a neutralizer is installed, periodic replacement of the limestone (or neutralizing agent) will be required. The rate of depletion of the limestone varies with usage of the boiler. During the first year of boiler operation, check the neutralizer every few months for depletion.
7. Route the drain line to a nearby floor drain (2), laundry tub (3), or condensate pump (4). If the boiler condensate outlet is lower than the drain, you must use a condensate removal pump (kit p/n 554200 available from HTP).

8. An error will appear on the boiler display if condensate line is blocked. The boiler will not operate with a blocked condensate line. It is extremely important to have this condition repaired by a qualified service technician.

NOTE: If a nearby laundry tub is used as a disposal for waste water from the washing machine, draining the condensate into this tub allows the soapy water discharge to neutralize the acidic condensate.

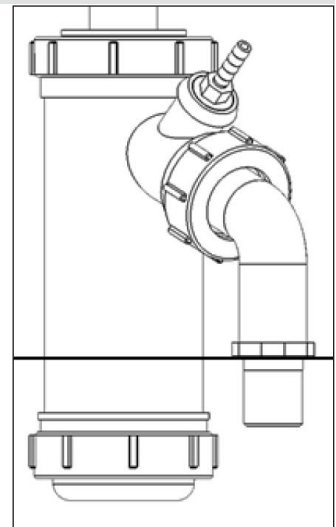

Figure 32 - Internal Condensate Trap

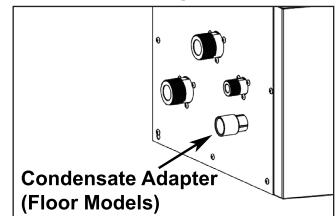

Figure 33 - Condensate Adapter (Floor Models)

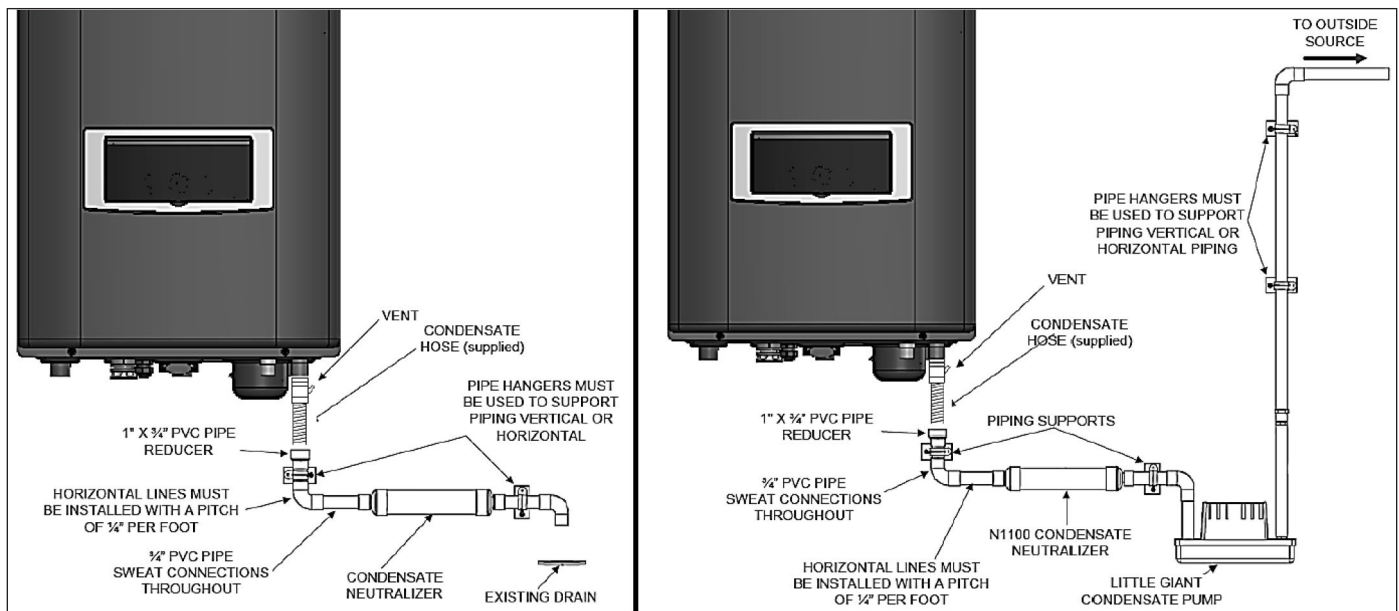

Figure 34 - Condensate Piping Details

Part 7 - Connecting Electrical Service

WARNING

Install wiring and electrically ground boiler in accordance with the authority having jurisdiction or, in the absence of such an authority, follow the National Electrical Code, NFPA 70, and/or CSA C22.1 Electrical Code-Part 1 in Canada. Failure to follow all applicable local, state, and national regulations, mandates, and building supply codes for guidelines to install the electrical power supply could result in property damage, serious personal injury, or death.

ELECTRICAL SHOCK HAZARD – To ensure safety, turn off electrical power supply at service entrance panel before making any electrical connections to avoid possible electric shock hazard. Failure to do so could result in property damage, serious personal injury, or death.

Jumping out control circuits or components WILL VOID product warranty and can result in property damage, personal injury, or death.

It is of extreme importance that this unit be properly grounded. It is very important that the building system ground is inspected by a qualified electrician prior to making this connection. Electrical power must only be turned on when the boiler is completely filled with cold water. Failure to follow these instructions could result in component or product failure, serious injury, or death.

CAUTION

Label all wires prior to disconnecting them when servicing the boiler. Wiring errors can cause improper and dangerous operation. Failure to follow these instructions may result in property damage or personal injury.

A. Wiring

The boiler is equipped with a three prong power cord. The boiler is limited to a maximum of 15 amps at 120 volts in use.

Ensure the Appliance is Properly Grounded

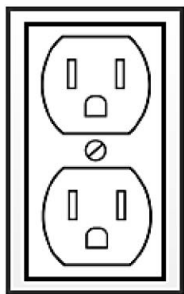

Grounded Electrical Outlet

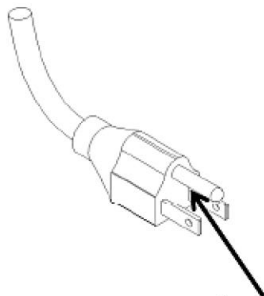

WARNING! DO NOT REMOVE THIS GROUNDING PRONG FROM THE APPLIANCE PLUG!

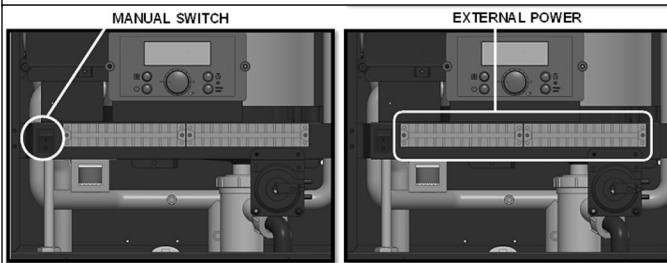

Figure 35 - Proper Grounding - Internal Manual Power Switch

1. This boiler must be properly grounded. Ensure the electrical receptacle is properly grounded. Do not remove the grounding prong from the boiler plug.
2. Do not attach the ground wire to either the gas or water piping.
3. The wiring diagrams in this manual are to be used for reference purposes only.
4. Refer to these diagrams and the wiring diagrams of any external controls used with the installation when wiring the boiler. Read, understand, and follow all wiring instructions supplied with the controls.
5. Do not disconnect the power supply when the boiler is in normal operation.

NOTE: For additional electrical protection, the use of a whole house surge protector is recommended. Damage caused by power surges IS NOT covered by the warranty.

NOTICE

If the boiler display does not turn on, first check the plug. Then check the electrical panel circuit breaker and reset if necessary. If the circuit breaker trips again, do not reset. Disconnect the plug and have a qualified technician diagnose the problem.

B. Dip Switches

There is one set of DIP switches. DIP switches 6 and 7 need to be set to OFF for the boiler to operate normally.

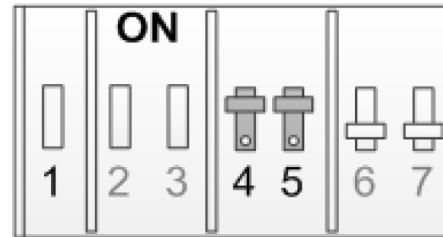

Figure 36 - Proper Grounding - Internal Manual Power Switch

DIP SWITCH		OFF	ON
1-3	Factory	Factory Settings - DO NOT CHANGE	
4	Vent Size	2"	3"
5	Gas Type	LP	NG
6	High Fire	Normal	High Fire
7	Low Fire	Normal	Low Fire

Table 19 - DIP Switch Group - NOTE: DO NOT CHANGE SWITCHES 1-3. THESE ARE FACTORY SETTINGS.

Maximum Flame Detecting Voltage	2.4V
Pre-Purge Time (Tp)	Maximum 10 seconds, Minimum 1 second
Safety Time (Igniting Time) (Ts)	3.5 seconds
Igniting Interval Time	20 seconds
Post-Purge Time (Tip)	3 minutes
Over-Heating 1, 2, 3, Protection Detection Time	<3 seconds
Pump 1 Post Circulating Time (T1pv)	1 minute
Pump 2 Post Circulating Time (T2pv)	1 minute
High and Low Water Level Detection Time	<6 seconds
High and Low Water Level Recovery Time	<6 seconds

Table 20 - System Control Settings

C. Wiring a Cascaded System

When wiring the boiler for Cascade operation, select one as the Master boiler. The remaining boilers will be designated Followers. See "Setting Up a Cascade System" for more details.

Connect the system sensor and outdoor sensor / 0-10V (if used) to the Master. For the Cascade System to work properly a system sensor must be installed. The system sensor should be located downstream of the boiler connections in the main system loop. The system sensor should be wired to the low voltage terminal strip marked for the system sensor. The Master control will use the water temperature from the system sensor to control operation of the Cascade System.

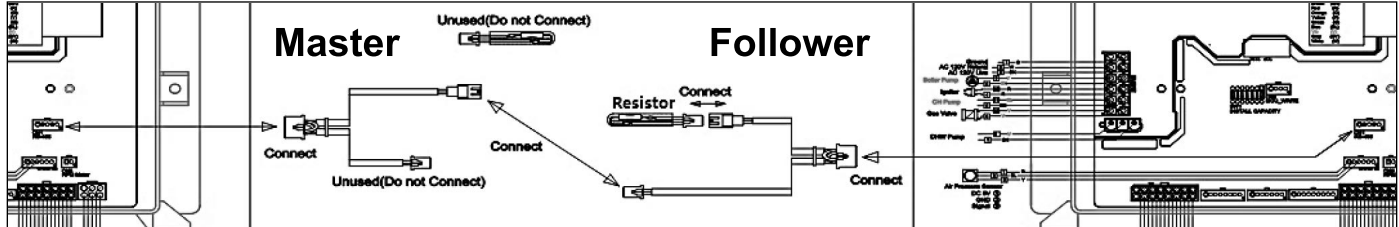

Figure 37 - Cascade Wiring Example

If outdoor reset / 0-10V is used, the outdoor sensor / 0-10V should be wired to the low voltage terminal strip marked for the outdoor sensor / 0-10V. If the outdoor sensor / 0-10V is connected, the Master control will calculate the water temperature set point based on the programmed reset curve parameters. If the outdoor sensor / 0-10V is not connected the Master control will maintain the fixed water temperature set point programmed into the control.

1. Connect the five pin connectors of the cascade communication cables to the control board of every unit. See Figures 37 and 38.
2. Connect the two pin male connector from the cascade communication cable of the first unit in the system to the open two pin female harness on the next unit in the system. Continue this for each unit in the system.

NOTE: The maximum distance between units is two and a half feet. See Figure 41. This maximum distance can be increased by connecting additional wire harnesses together. However, the number of units that can be cascaded will be reduced by one for every additional harness used.

3. Add a resistor to the cascade communication cable of the last unit. See Figure 39.

NOTE: Every cable comes with one resistor. Use only one resistor on the cascaded system. Discard the rest.

2. Connect the system sensor to the Master low voltage terminal strip. See Figure 41. Thermostat / outdoor sensor / 0-10V must be connected to the Master only.

NOTE: When using an outdoor sensor, the boiler's CH target will default to 20°F higher than the system sensor target temperature to 180°F.

NOTE: The DHW sensor / aquastat must be connected to the prioritized Follower boiler. When using more than one cascaded boiler for DHW priority, an aquastat must be used and wired in parallel to each boiler used for DHW priority.

NOTE: After the cascaded system is set, if you manually turn off the Cascade Master at the display the entire system will shut down.

NOTE: After the cascaded system is set, DO NOT turn off a Cascade Follower at the display until you disconnect the cascade cable.

CAUTION

When installing a cascaded system, it is important that the boilers are the same model.

When selecting more than one boiler for DHW priority in a cascade loop, an aquastat must be used, and connected in parallel to each boiler used for DHW priority.

Failure to follow these instructions will result in improper system operation, wasted time, money, and possible property damage and personal injury. Such damages ARE NOT covered by product warranty.

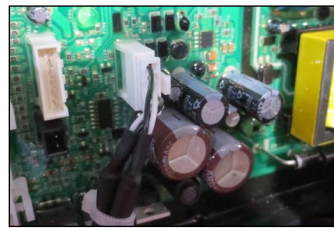

Figure 38 - Cable Wired to Board

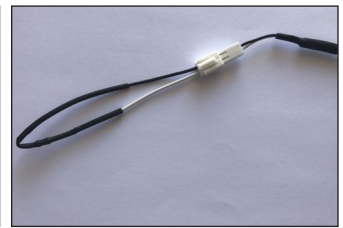

Figure 39 - Installed Resistor

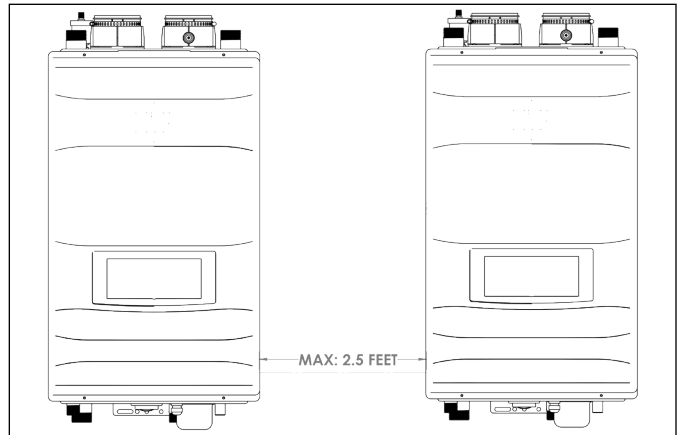

Figure 40 - Maximum Distance Between Wired Cascaded Units

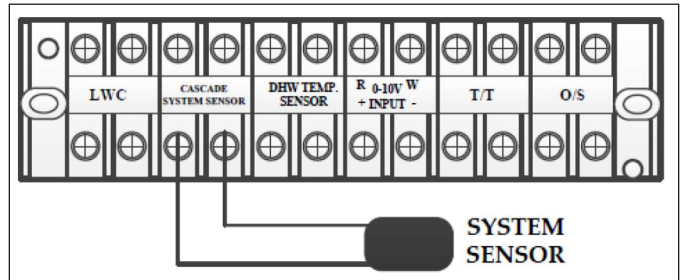

Figure 41 - Wired System Sensor

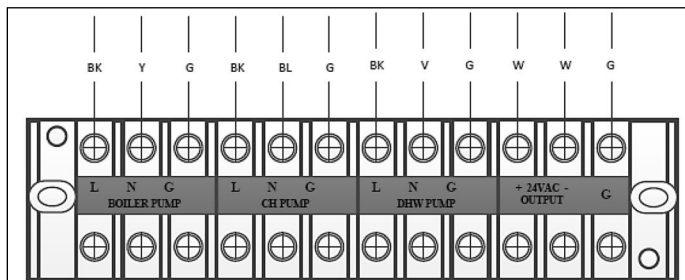

Figure 42 - Line Voltage Wiring Detail

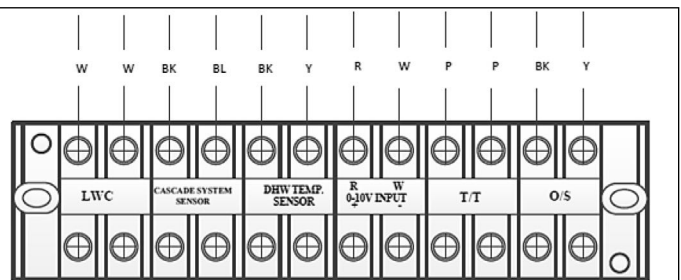

Figure 43 - Low Voltage Wiring Detail

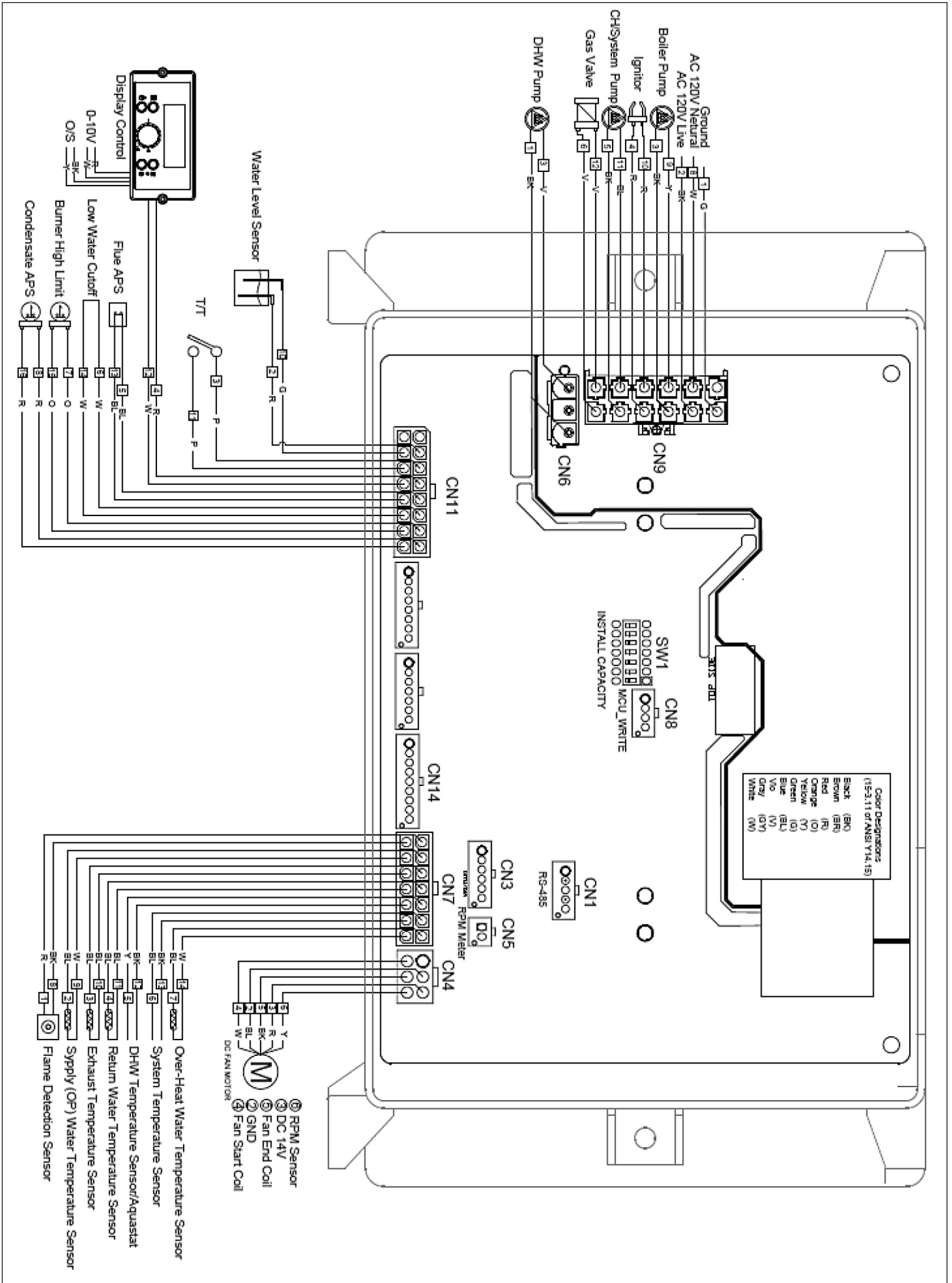

Figure 44 - Electrical Wiring Diagram

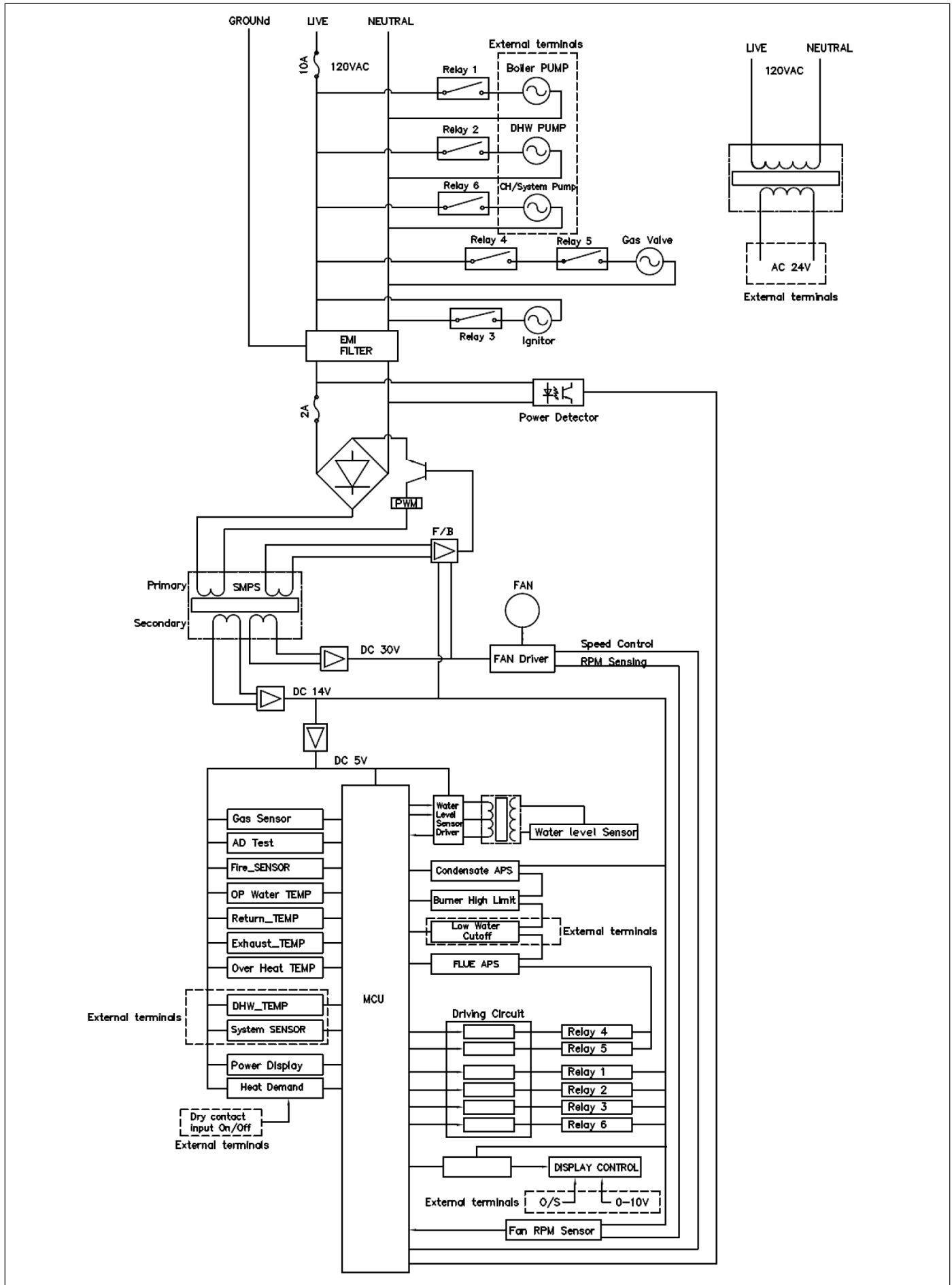

Figure 45 - Ladder Diagram



Connector			Description	HT Selv	
No. of Location	Pin	Board Silk			
CN9 65001WS-12	1		GROUND	HT (120V~) AC	
	2	L	Power Supply Line		
	3	CP1	Boiler Pump Power Supply (Live)		
	4	IT	Ignitor Power Supply		
	5	L/(HT)	CH / System Pump Power Supply (Live)		
	6	GV	Gas Valve Power Supply		
	7		-		
	8	N	Boiler Pump Power Supply (Neutral)		
	9-12		Power Supply (Neutral)		
CN6 LW6A4-03	1	CP2/3WAY	DHW Pump Power Supply (Live)		
	3		DHW Pump Power Supply (Neutral)		
CN1 SMW250-03	1	RS-485	RS-485 +	Cascade Connection	
	2		RS-485 -		
	3		-		
	4		RS-485 +		
	5		RS-485 -		
CN4 LWD1140-06	1	FAN	NOT USED	-	
	2		GND		
	3		VDD		SELV (14V) DC
	4		Fan power (start coil)		SELV (8 - 26V) AC
	5		Fan power (end coil)		
	6		Fan speed feedback signal		SELV (14V) DC
CN8 SMW250-04	1	MCU ISP	GND	SELV (5V) DC	
	2		ISP / Reset Port		
	3		ISP TOOL0 Data Port		
	4		VCC		
CN11 LWD1140-16	1	HWL	NOT USED	SELV (12V~) AC	
	8				
	2	LWL	Water Level Sensor		
	10				
	3	HD	Central Heating Demand (T/T)	SELV (5V) DC	
	11				
	4	TH	Display Control		
	12				
	5	APS	Flue Air Pressure Switch		
	13				
	6	EL	Low Water Cut-Off (External)	SELV (14V) DC	
	14				
	7	BL	Burner High Limit		
	15				
	8	HL	Condensate Air Pressure Switch		
	16				

Table 21 - Boiler Wiring 1

Connector			Description	HT SELV
No. of Location	Pin	Board Silk		
CN7 LWD1140-14	1	F.S	Flame Sensor	SELV (5V)
	8			
	2	O.P.S	Supply Operating Water Temperature Sensor	
	9			
	3	D.H.S	Exhaust Temperature Sensor	
	10			
	4	I.S	Return Water Temperature Sensor	
	11			
	5	B.G.S	External DHW Temperature Sensor / Aquastat	
	12			
	6	S.T.S	External System Temperature Sensor	
	13			
	7	S.P.S	Overheat Temperature Sensor	
	14			
CN14 SMW250-09	1 - 9	IWM	NOT USED	
CN3 SMW250-06	1 - 6	FLUX1	NOT USED	
CN5 SMW250-10	1	RPM	Fan RPM Check	
	2		GND	

Table 23 - Boiler Wiring 2

Part 8 - Gas Connections

WARNING

FIRE AND/OR EXPLOSION HAZARD

To avoid serious injury or death, the gas line installation and the gas line inlet pressure test must be done by a licensed professional.

Ensure the gas on which the boiler will operate is the same type specified on the rating plate (natural gas or LP gas). This boiler must be converted into propane operation unless specifically manufactured for use with propane. Follow Gas Conversion Manual instructions (separate document). Propane ready boilers have the suffix "LP" after the model serial number. Failure to follow these instructions could result in property damage, personal injury, or death.

Make sure the gas line pressures are within normal limits. Pressures outside normal limits can result in poor performance and hazardous operating conditions. Failure to do so could result in property damage, personal injury, or death.

A. Gas Pipe Sizing Tables

1. Gas Pipe Sizing

This information is for reference use only. Refer to gas pipe manufacturer specifications for actual delivery capacity. The DOE standard for Natural Gas is 1100 BTU/ft³. Contact the local gas supplier for actual BTU/ft³ rating.

2. Natural Gas Pipe Sizing

The following table lists maximum capacity of pipe in cubic feet of gas per hour for gas pressures of 14" or less and a pressure drop of 0.5 inches water column, based on a 0.60 specific gravity for natural gas.

Pipe Size (in.)	Length of Pipe (Feet)										BTU's Per Hour x 1,000
	10	20	30	40	50	60	80	100	150	200	
3/4	360	247	199	170	151	137	117	104	83	71	Schedule 40 Metallic Pipe (0.60 Specific Gravity, 0.5 WC Pressure Drop)
1	678	466	374	320	284	257	220	195	157	134	
1 1/4	1390	957	768	657	583	528	452	400	322	275	
1 1/2	2090	1430	1150	985	873	791	677	600	482	412	
2	4020	2760	2220	1900	1680	1520	1300	1160	928	794	
3	11300	7780	6250	5350	4740	4290	3670	3260	2610	2240	
4	23100	15900	12700	10900	9660	8760	7490	6640	5330	4560	

Table 22 - Natural Gas Delivery Capacity - Refer to ANSI Z223.1 - National Fuel Gas Code, Latest Edition

3. LP (Liquid Propane) Gas Pipe Sizing

Contact gas supplier to size pipes, tanks, and 100% lockup gas pressure regulator. Adjust propane supply regulator provided by the gas supplier for 14 inches w.c. maximum pressure.

B. Gas Connection Requirements

1. The gas connection fitting on the boiler is 3/4" NPT. **NOTE:** The pipe size must not be less than 3/4".
2. The supply line must be sized for the maximum output of the boiler being installed. If there are additional gas appliances from the main supply line, measure the size of the supply line according to the COMBINED total maximum BTUH draw for the appliances as if they were operating at the same time.
3. Measure the length of the gas supply line from the gas meter to the boiler. Boiler must be installed downstream of the gas meter to ensure adequate gas supply. Use the tables in this manual or refer to the gas line manufacturer's sizing information to determine the correct supply pipe size.
4. The National Fuel Gas Code (NFPA 54) requires that a sediment trap (drip leg) be installed in the gas line on appliances not so equipped. The drip leg must be accessible, a minimum of 3" in length, and not subject to freezing conditions. See Figures 46 and 47.
5. A manual gas shut-off valve should be installed in the gas supply line close to the boiler. See Figures 46 and 47 for detail.

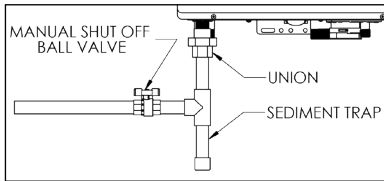

Figure 46 - Gas Line with Shut-Off and Sediment Trap Detail - Wall Model

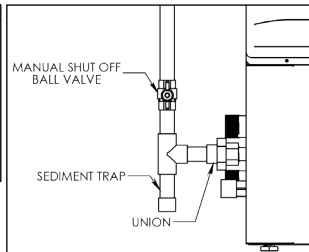

Figure 47 - Gas Line with Shut-Off and Sediment Trap Detail - Floor Model

6. To facilitate any future maintenance, it is also recommended that an approved gas union fitting be installed in the supply line between the shut-off valve and the 3/4" NPT connection on the boiler.
7. Use a manometer to test the gas pressure to make sure it meets the minimum standards and does not exceed the maximum standards of the boiler.
8. Leak test the gas line pipe before placing the boiler in operation. Only use approved leak detector liquid solutions to check for leaks.
9. Do not operate the boiler until all connections have been completed and the heat exchanger is filled with water.

C. Additional Precaution for Excess Flow Valve (EFV)

If an excess flow valve (EFV) is in the gas line, check the manufacturer's minimum and maximum flow capacity ratings. An improperly sized EFV will not allow for a full flow of gas to the boiler and will cause the boiler to malfunction. See Figure 48.



Figure 48 - Excess Flow Valve (EFV)

D. Checking Gas Pressure at the Boiler for Proper Operation

NOTE: Refer Figure 49 when checking gas pressure. Loosen the bolts before checking the gas inlet pressure.

1. The boiler and its individual shutoff valve must be disconnected from the gas supply piping system during any pressure testing of the system at test pressures greater than 1/2 psi (3.5 kPa).
2. The boiler must be isolated from the gas supply piping system by closing its individual manual shutoff valve during any pressure testing of the gas supply piping system at test pressures equal to or less than 1/2 psi (3.5 kPa).

The minimum and maximum inlet gas line pressures must meet the requirements shown in Table 24.

Natural or LP Gas	
Minimum Pressure	3.5"WC
Maximum Pressure	14"WC

Table 24 - Gas Pressure Requirements

NOTICE

Do not fire (operate) the boiler until all connections have been completed and the heat exchanger is filled with water. Doing so will damage the boiler and void the warranty.

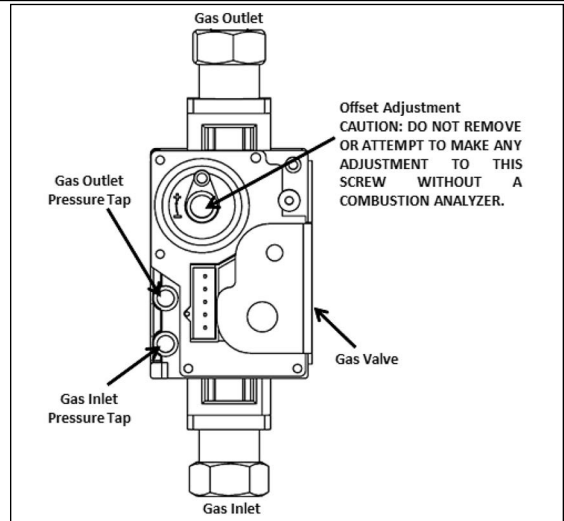

Figure 49 - Gas Valve Detail

E. Setting and Verifying the Combustion Setting

1. After the boiler has fired, flip DIP switch seven (7) to the ON position (low fire). Proceed to check boiler combustion values.

NOTE: Use a calibrated combustion analyzer to ensure CO and CO2 values are within the range shown in Table 25.

WARNING

It is required to use a calibrated combustion analyzer to verify final adjustment according to the combustion chart (Table 25). Failure to do so could result in serious personal injury or death.

If the readings obtained are lower or higher than the combustion readings in Table 25, use a 4mm Allen key to adjust the offset screw in a clockwise (positive) or counterclockwise (negative) direction (approximately 1/4 turn). See Figure 49. Check your combustion values. Repeat this procedure until the values obtained on the calibrated combustion analyzer agree with those stated in Table 25. **NOTE:** If the boiler makes a whistling sound (harmonics) at low fire, adjust the offset screw in a clockwise (positive) direction (approximately 1/8 turn). Check your combustion values and ensure they agree with those stated in Table 25 before proceeding.

2. When low fire settings have been obtained, flip DIP switch seven (7) to its original (OFF) position. This will return the boiler to normal operation.
 3. Flip DIP switch six (6) to ON (high fire). Again check combustion readings with a calibrated combustion analyzer.
- NOTE:** DO NOT adjust the gas valve offset screw at high fire. The offset screw is only used to adjust combustion values at low fire.
4. When complete, flip DIP switch six (6) to its original (OFF) position. This will return the boiler to normal operation.
 5. Allow boiler to operate normally. Ensure it is operating properly.
 6. Use a Phillips Head screwdriver to reinstall the boiler cover.

WARNING				
It is very important that the combustion system be set within the recommended CO measurements listed in Table 25. Visually looking at the burner does not determine combustion quality. Failure to measure combustion with a calibrated combustion analyzer and set the throttle within the recommended CO measurements could result in property damage, severe personal injury, or death.				
	Natural Gas		LP Gas	
Fan Speed	Low	High	Low	High
CO PPM	≤175		≤175	
CO ₂ (%)	8 - 9 1/2	8 1/2 - 10	9 - 10 1/2	9 1/2 - 11

Table 25 - Combustion Settings

⚠ **WARNING**

Breathing Hazard - Carbon Monoxide Gas



- Do not operate heater if flood damaged.
- Install vent system in accordance with local codes and manufacturers installation instructions.
- Do not obstruct heater air intake or exhaust. Support all vent piping per manufacturers installation instructions.
- Do not place chemical vapor emitting products near unit.
- According to NFPA 720, carbon monoxide detectors should be installed outside each sleeping area.
- Never operate the heater unless it is vented to the outdoors.
- Analyze the entire vent system to make sure that condensate will not become trapped in a section of vent pipe and therefore reduce the open cross sectional area of the vent.

Breathing carbon monoxide can cause brain damage or death. Always read and understand instruction manual.

LP-304

Part 9 - Controls

A. Control and Display Overviews

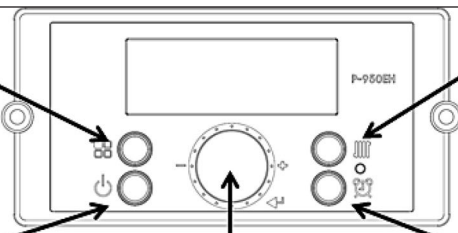

Hold this Button More than 5 Seconds
When Control Panel Power is ON
Status Display Mode
When Control Panel Power is OFF
Installer Mode

Press this Button Less than 5 Seconds
Change CH Set-Point Temperature
86 – 180°F (30 – 82°C)

Press this Button Less than 5 Seconds
Turns Control Power Panel ON/OFF

Press this Button Less than 5 Seconds
Select Menu by Pressing Dial Button
Scroll Through and Adjust Values by Turning Dial Clockwise(+) or Counterclockwise(-)

Hold this Button More than 5 Seconds
Change Current Time Setting
Year/Month/Date/Hour/Minute/Day of Week

Figure 50 - Control Panel Detail

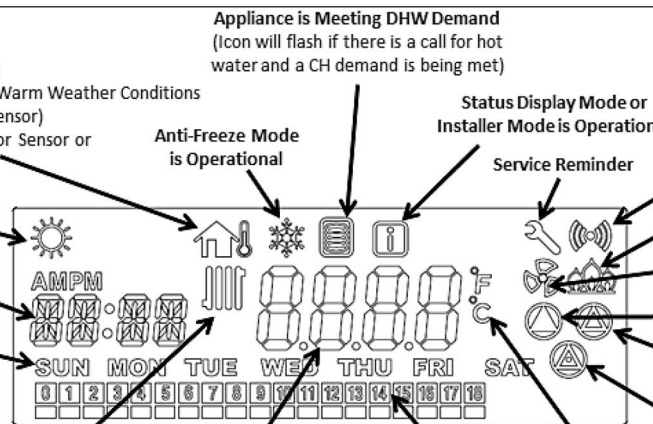

Outdoor Temperature Mode:
Shuts Down CH Mode during Warm Weather Conditions (Requires Optional Outdoor Sensor)
NOTE: Icon will Flash if Outdoor Sensor or 0-10 Volt is not Connected.

Appliance is Meeting DHW Demand
(Icon will flash if there is a call for hot water and a CH demand is being met)

Status Display Mode or Installer Mode is Operational

Warm Weather Shutdown Operational

Anti-Freeze Mode is Operational

Service Reminder

Current Time

Appliance is in a Communication State

Flame On

Current Day of Week

Fan On

Boiler Pump On

Appliance is Operating in CH Mode
(Icon will flash if there is a call for heat and a DHW demand is being met)

CH / System Pump On

DHW Pump On

Eight (8) Segment Display with Colon and Decimals Displays Numerals and Characters

Celsius and Fahrenheit Indicators

Cascade Status
Displayed Number Indicates Cascaded Unit
Full On Rectangular Icon Under Number Indicates Unit is Running
Flashing Rectangular Icon Under Number Indicates Unit Error

Figure 51 - LCD Display

The LCD display also features a backlit lamp that will illuminate:

- When a user action is detected (a button is pressed)
- The display has timed out for approximately 2 minutes

B. Start-Up Sequence

After the appliance is powered ON, the LCD display shows a sequence of information. The icons will flash, followed by various indicators that describe the appliance controller and software versions. It will take the appliance roughly 15 seconds to cycle through the Start-Up Sequence.

Display Items	Time for Display	Remarks
LCD Test	1 sec	All segments "ON"
	0.5 sec	All segments "OFF"
Category: UFT	1 sec	Pdn
	1 sec	0071
Software Version for Front Panel	1 sec	SPn
	1 sec	00.xx
Software Version for Boiler	1 sec	SFn
	1 sec	xx.xx
Hardware Version for Boiler	1 sec	Hdn
	1 sec	00xx

Table 26 - Start-Up Sequence

NOTE: When the boiler is powered ON, the fan will operate at maximum speed for 1 minute to purge the air and any fumes from the intake and exhaust pipes.

After start-up, the display appears as follows.

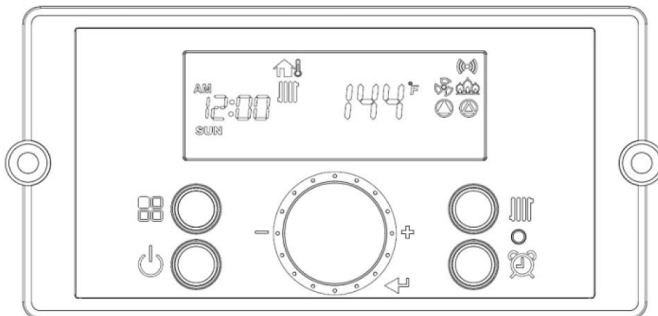

Figure 52 - Initial Display Screen

The Control System can operate through user and service modes that have specific LCD outputs and dedicated controls, including:

- Changing the CH Set-Point Temperature
- Changing Time
- Status Display
- Installer Mode
- Error Mode
- Outdoor Temperature Mode

C. Changing the CH Set-Point

Press the button when the display panel is powered ON to change the CH Set-Point. The display will appear as follows.

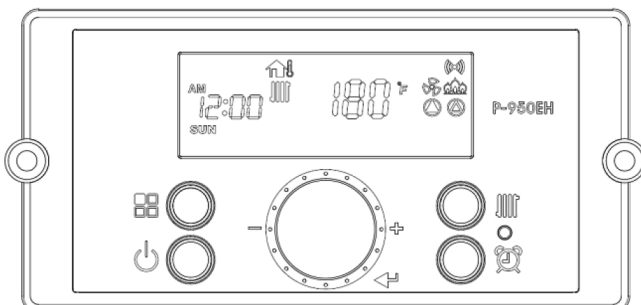

Figure 53 - CH Set-Point Screen

The set-point temperature will flash when the CH Set-Point can be changed.

Factory CH Set-Point is 180°F (82°C). CH Set-Point range is 40 – 180°F (4.44 – 82°C).

Turn the dial counterclockwise to lower and clockwise to raise the CH set-point. After changing the temperature, press the button to save the set-point.

NOTE: The CH Set-Point cannot be changed by pressing the button if an outdoor sensor or 0-10V is connected to the boiler. When using an outdoor sensor, the boiler will automatically change the target temperature based on the outdoor reset curve. When using 0-10V, the boiler will automatically change the target temperature based on input voltage.

NOTE: If input voltage is less than 1.5V the 0-10V will be ignored.

D. Changing the Time

Press and hold the button for five seconds when the display panel is powered ON to change the time. The settings can be adjusted as follows: Year / Month / Date / Hour / Minute / Day of Week.

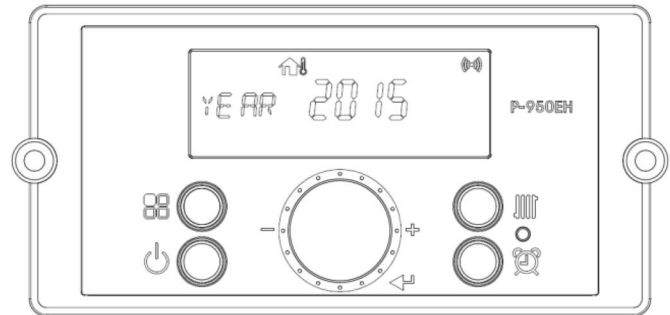

Figure 54 - Changing the Time Screen

Turn the dial counterclockwise to lower and clockwise to raise the current time setting. After changing the setting, press the button to save it. The next adjustable setting will appear. After the time and date have been set, press the button to save and return to the main screen.

E. Status Display

Status Display will activate when button  is pressed and held for five seconds at Standby Mode when the display panel is powered ON.

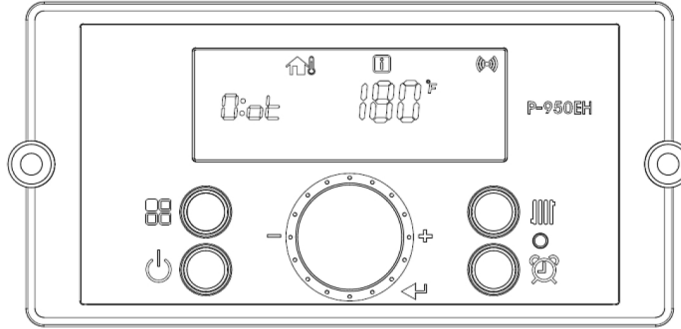







Figure 55 - Status Display Screen

Display (Main Menu)	Display (Sub Menu)	Detail		Description	
O:ot		Outdoor Temperature		Current Outdoor Sensor Temperature (When --- is displayed, outdoor sensor is not connected.)	
A:ln		0-10V Display		Current Voltage of 0-10V Input (When --- is displayed, 0-10V is not connected.)	
b:tt		CH target temperature		Current CH target temperature	
C:lt		CH return water temperature		Current CH return water temperature	
d:Fr		Fan speed (RPM)		Current fan speed (RPM)	
E:oP		CH supply water temperature		Current CH supply water temperature	
F:Eh		Exhaust temperature		Current exhaust temperature	
H:dH		Indirect DHW tank temperature * If OFF is displayed DHW sensor is not connected		Display: Current DHW tank temperature measured by the indirect tank sensor (7250P-325) Display: OFF – when a mechanical aquastat is connected and the contact is open, or no sensor is connected. Display: ON - When a mechanical aquastat is connected and the contact is shorted.	
I:oH		CH Overheat Temperature		Current CH Overheat Temperature	
L:rt	1:PH	Burner Operation Time	Power supply	L:rt on display on sub menu	Time boiler has been powered in 1000 hour units
	2:rh		Burner operating time		Time burner has operated in 1 hour units
	3:rH		Burner operating time		Time burner has operated in 1000 hour units
	4:lt		Ignition attempts		Number of ignition attempts: 10 times the displayed unit
	5:IH		Ignition attempts		Number of ignition attempts: 10,000 times the displayed unit
M:CC	SELF	Capacity of Master (percentage)		Percentage of Master Unit Running	
	ALL	Total Cascade Capacity (percentage). This icon will only be displayed when the units are in cascade mode. NOTE: This index will only be shown in cascade mode.		Percentage of cascade units running. This screen shows the overall cascade power output. The range of this value of boilers communicating with the Master x 100. For example, if eight (8) boilers are connected and communicating, the maximum cascade power is 800%. Range: 0-100%	
	F1 - F19	Capacity of individual boilers (percentage). This icon will only be displayed when the units are in cascade mode.		Percentage of each cascade units running. Ex. M, F1, F2,	
N:St		System Temperature (Cascade Mode)		Current System Temperature NOTE: This index will only be shown in Cascade Mode. If system sensor is not connected, the screen will display OF or OC.	

Table 27 - Status Display Screen Descriptions

Turn the dial  counterclockwise and clockwise to scroll through the displayed parameters. To view parameter details, press the  button at the appropriate screen. Press the  or  buttons to leave the parameter. Press the  button again to return to Operation Mode.

F. Installer Mode

Installer Mode will activate when button  is pressed and held for five seconds while the boiler display is powered Off.

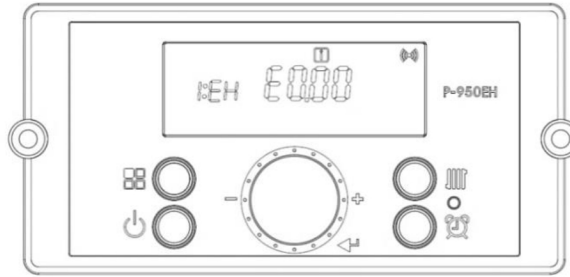





Figure 56 - Installer Mode Screens

Display	Default	Detail	Description
1:EH	E0.00	Error history up to 10	Check ten most recent Error Codes (E0 - E9)
2:cE	OFF	Clear Error History	Select "ON" to Clear Error History. Range: ON or OFF
3:ln	OFF	System Reset (Factory Setting)	Select "ON" to restore system to default factory settings (Burner operation time, Ignition cycles, and Supply power time will not be reset. See Functions 14 and 15.) Range: ON or OFF
4:OH	68F	Maximum Outdoor Temperature	When used with an outdoor sensor, sets the maximum outdoor design temperature for the system design. Maximum outdoor temperature must be set 9°F above the minimum outdoor temperature. Range: (Minimum Outdoor Temperature + 9°F) to 110°F
5:OL	5F	Minimum Outdoor Temperature	Sets the minimum outdoor design temperature for the system. Minimum outdoor temperature must be set 9°F below the maximum outdoor temperature. Range: -4°F to (Maximum Outdoor Temperature - 9°F)
6:cH	180F	Maximum Supply Temperature	Sets the maximum design supply temperature based on the minimum outdoor design temperature. Maximum supply temperature must be set at least 9°F above the minimum supply temperature. Range: (Minimum Supply Temperature + 9°F) - 180°F
7:cL	86F	Minimum Supply Temperature	Sets the design supply water temperature based on the maximum outdoor design temperature. Minimum supply temperature must be set at least 9°F below the maximum supply temperature. Range: 40°F to (Maximum Supply Temperature - 9°F) Default: 86°F
8:OF	68F	Warm Weather Shutdown	When outdoor temperature sensor is used, warm weather shut down will shut down CH Mode if the programmed outdoor temperature is exceeded. Range: 50 - 110°F
9:bt	0	Boost Function	When Outdoor Temperature Mode is used, Boost Function increases the CH set point temperature by the Boost Degree temperature [10:bd]) at time intervals (Boost In- terval [11:bl]). A space heating demand must be active without a DHW demand over the Boost Function set period of time (9:bt) for boost to activate. Boost continues until the boiler reaches the maximum supply temperature set point (6:cH) based on the outdoor reset curve. The boiler will return to normal operation after the thermo- stat is satisfied. Range: 0 - 120 min NOTE: "0" means boost function is OFF.
10:bd	10F	Boost Degree	Sets the temperature added to the boiler target set point based on the Outdoor Temperature reset curve. Range: 5 - 15F Default: 10F
11:bl	20 MIN	Boost Interval	Sets the interval time when the boiler will increase the temperature by the Boost Degree. Ex: Initial Boost: 10F. After 20 MIN Interval: Boost will increase CH set point temperature another 10F. After another 20 MIN Interval: Boost will increase CH set point temperature another 10F. This will continue until the boiler reaches the maxi- mum supply temperature set point (6:cH) based on the outdoor reset curve, or until the thermostat is satisfied. Range: 0 - 120 MIN Default: 20 MIN
12:FH	00	Maximum Fan Speed	Adjusts maximum fan speed. Range: -30 to +30
13:FL	00	Minimum Fan Speed	Adjusts minimum fan speed. Range: -30 to +30
14:dr	NO	Reset Burner Operation Time	Select "YES" to Reset Burner Operation Time Range: YES or NO
15:dl	NO	Reset Ignition Cycle	Select "YES" to Reset Ignition Cycles Range: YES or NO

Display	Default	Detail	Description	
16:Ft	1	CH Anti-Cycling Time	This function delays burner operation during CH mode Range: 0 - 20 min	
17:bo	30F	Set Differential Temperature to Turn Burner "ON"	When set, the appliance will operate to heat CH water when water temperature falls below a differential setting. Example: If set point is 180°F and differential is 30°F, the appliance will turn on when CH water temperature falls below 150°F. Range: 5 - 30°F	
18:cb	100	Heating capacity	Set heating combustion rate Range: 50 - 100%	
19:db	100	DHW capacity	Set DHW combustion rate Range: 50 - 100%	
20:PE	1 MIN	Heating Pump Post-Purge Time, T/T Satisfied	Allows the user to set the appliance pump post purge time once the thermostat is satisfied. Range: 0-5 minutes	
21:dH	120F	Indirect Storage Tank Temperature Storage Point	Sets Maximum Indirect Storage Tank Temperature Range: 95 - 180°F	
22:dd	7F	Indirect Storage Tank Differential Set Point	DHW Differential Set Point Range: 5-30 F	
23:Pr	1 MIN	DHW Pump Post Run Time	DHW Pump Post Run Time Range: 0-10 Min	
24:DP	30 MIN	DHW Priority Timer	DHW Priority Timer Range: 0 - 60 Min NOTE: If zero is selected DHW will always be priority.	
25:ST	180F	Boiler Supply Indirect Storage Tank Temperature	Boiler Supply Indirect Tank Temperature Range: 120 - 180 F	
26:FP	ON	System Freeze Protection Mode (Activates Based on Internal Supply Water Temperature)	Freeze Protection Operation	Range
			Stage 1 - If control detects water temperature of 46°F (8°C) and below, it turns the DHW indirect and CH pumps On for 600s and Off for 30s. This cycle repeats until the control detects water temperature of 50°F (10°C) and above.	ON or OFF (Default: ON) NOTE: If using boiler for Snow Melt applications, turn Freeze Protection OFF.
			Stage 2 - If control detects water temperature of 41°F (5°C) and below, it turns the burner on to meet a target temperature of 104°F (40°C). The burner and DHW indirect and CH pumps will run continuously during this stage until the control detects water temperature of 104°F (40°C) and above.	
			Stage 3 - If control detects water temperature of 34°F (1°C) and below, Er: 85 will appear on the display. The control turns the burner on to meet a target temperature of 104°F (40°C). The burner and DHW indirect and CH pumps will run continuously during this stage until the control detects water temperature of 104°F (40°C) and above.	
27:cn	0	Cascade Address	Cascade Address Range: 0 (Master), 1 (follower 1), ..., 20 (follower 19). Default: 0. NOTE: "28:cP" needs to be set with total number of units in the cascade parameter before setting "27: cn" NOTE: The Master boiler must always be addressed 0.	
28:cP	1	Cascade Parameter	Number of Units Cascaded Range: 01 - 20	
29:Eh	OFF	N/A	N/A	
30:Cr	Cr:at	Auto	Automatic Rotation (default)	The first unit to operate when there is a DHW call is the unit that ran the least amount of time during the prior heat calls (burner ON time).
	Cr:Ct	48	Cascade Rotation Time	Cascade Rotation Time NOTE: If unit is set to run continuously, the Timed parameter must be set, NOT Automatic Rotation (Cr:at) to ensure even unit run time. Range: 0 - 240 Hours
31:CT	180F	Cascade System Temperature	Cascade System temperature: Range: 40F - 180F	
32:Cd	10F	Cascade System Temperature Differential (Burner On)	Cascade System Temperature Differential (burner ON) Range: 5-30 F	

Display	Default	Detail	Description	
33:HA	0-2	High Elevation Mode	This boiler may be installed at elevations up to 10,000 feet and operate on either Natural or LP. The appliance will de-rate by 4% for each 1000 feet above sea level. Select the appropriate installation location as described below. Selects Installation Location for Proper Boiler Operation at Altitude: 0-2 for installation locations from sea level to 1999 feet 2-5 for locations from 2000 to 4999 feet 5-8 for locations from 5000 to 7999 feet, 8-10 for locations from 8000 to 10000 feet Default: 0 – 2 NOTE: Use a calibrated combustion analyzer to ensure CO and CO2 are within the ranges shown in this manual. Adjust the offset screw in the clockwise (positive) or counterclockwise (negative) directions (approximately 1/8 turn) if the measured CO2 value on LOW FIRE is out of range.	
34:AP	AP:cP	5	CH System Pump and DHW Indirect Pump Test Mode	This function sets the time to run Boiler pump, CH System pump or DHW Indirect pump to purge air from the system. Range: 1 – 30 minutes
	cP1:OFF or cP1:ON	OFF	Boiler and CH System Pumps Test Mode	Turn this function on to activate Boiler pump and CH System pump. Only works in Installation Mode. Turns off during normal operation.
	cP2:OFF or cP2:ON	OFF	DHW Indirect Pump Test Mode	Turn this function on to activate DHW Indirect pump. Only works in Installation Mode. Turns off during normal operation.
35:SS	SS:Sd	OFF	OFF	Sets the date of the next service reminder: XX/XX/XXXX (MONTH/DAY/YEAR). NOTE: A wrench will appear on the display panel when service is due.
		YEAR	Service Reminder Date	
		MON		
		DATE		
SS:br	00	Service Reminder Run Hours	Sets the next service reminder based on burner run hours. (OFF, 0 - 9000 hours)	
36:UC	FAH (F)	FAH(F)	Temperature Measurement Unit	Allows the user to change the temperature measurement unit from Fahrenheit to Celsius.
	CEL (C)			
37:CM	OFF	CH Step Modulation	Allows the user to turn ON the step modulation, which regulates burner output in six steps at one minute intervals. Step modulation will start at the last modulation rate of the boiler and work up one minute at a time. Default: OFF (Selection: OFF or ON).	
38:dM	OFF	DHW Step Modulation		
39:SA	AquA	AquA	Select AquA or SEnS	An aquastat or indirect sensor can be used when using an indirect water heater. Range: AquA or SEnS. Default: AquA NOTE: If an aquastat is used and SEnS is selected, the boiler will not operate and Er.32 will display. If a sensor is used and AquA is selected, the boiler will not operate. No error will display.
	SEnS			
40:BP	OFF	Boiler Pump Operation Mode	When turned "ON" the Boiler pump can operate while there is a DHW demand. NOTE: This can be useful when the boiler is used to retrofit an older unit and DHW piping is connected to the system loop.	

Table 28 - Installer Mode Descriptions

Turn the dial  counterclockwise and clockwise to scroll through the displayed parameters. To view parameter details, press the  button at the appropriate screen. Turn the dial  counterclockwise and clockwise to change the selected parameter. To save the setting press the  button.

To leave Installer Mode, press the  button again. The display will return to power off mode.

G. Setting Up a Cascaded System

CAUTION

A maximum of eighteen (18) models may be installed in a cascaded system. Installing more than the maximum amount of boilers in a cascaded system will result in system problems, property damage, and premature boiler failure. Such problems ARE NOT covered by product warranty.

WARNING

For each floor containing bedroom(s), a carbon monoxide detector and alarm shall be placed in the living area outside the bedrooms, as well as in the mechanical room that houses the boiler. Detectors and alarms shall comply with NFPA 720 (latest edition). Failure to comply with these requirements could result in product damage, severe personal injury, or death.

When setting up a cascade system, each individual boiler control must be programmed for cascade operation.

Program the Master and Follower Boilers:

To program the cascade system, first enter the Installer Mode. Scroll down to and select the following parameters on each boiler in the system:

1. **28:cP** – Set the number of units in the cascade loop [range from 1-20].
2. **27:cn** – Next, set the cascade address (Master should always be addressed 0) [range from 0-19]. 27:cn cannot be changed until 28:cP is set.

NOTE: The above parameters should be set on every unit in the cascade loop. To remove a follower from the cascade system, the Master display panel power needs to be turned off, or the cascade cable needs to be disconnected from the unit that is being removed from the cascade system.

Program the Master Boiler:

To finish programming the cascade system, enter the Installer Mode on the Master Boiler ONLY. Scroll down to and select the following parameters:

1. **30:Cr – MASTER ONLY** - Set cascade rotation mode to Automatic rotation or Timed rotation.
NOTE: If unit is set to run continuously, the Timed parameter must be set, NOT Automatic.
2. **31:Ct – MASTER ONLY** - Set system target temperature controlled by the system sensor (Range: 40-180°F, Default: 180°F).

NOTE: To ensure proper operation, the boiler set point is defaulted at 20°F higher than the system set point to a maximum of 180°F.

NOTE: The Master boiler will display Er: 30 if the boilers are set on Cascade mode and a system sensor is not connected. Boiler setpoint will be the same as the system sensor setpoint until the issue is remedied.

See Installer Mode for details.

CAUTION

When installing a cascaded system, it is important that the boilers are the same model.

When selecting more than one boiler for DHW priority in a cascade loop, an aquastat must be used and connected in parallel to each boiler used for DHW priority.

Failure to follow these instructions will result in improper system operation, wasted time, money, and possible property damage and personal injury. Such damages ARE NOT covered by product warranty.

H. Outdoor Temperature Mode (Optional)

NOTE: If the system requires a fixed operating temperature, the outdoor sensor is not required and should not be installed.

There is no connection required if an outdoor sensor is not used in the installation.

1. Use a minimum 22 AWG wire for runs of 100 feet or less and minimum 18 AWG wire for runs of up to 150 feet.

2. Mount the outdoor sensor on an exterior surface of the building, preferably on the north side in an area that will not be affected by direct sunlight and will be exposed to varying weather conditions.

NOTE: For correct mounting procedures, follow instructions provided with the sensor.

NOTE: If sensor wires are located in an area with sources of potential electromagnetic interference (EMI), the sensor wires should be shielded, or the wires routed in a grounded metal conduit. If using shielded cable, the shielding should be connected to the common ground of the boiler.

NOTE: Outdoor Temperature Mode Icon on the display will flash if an Outdoor Sensor or 0-10 Volt is not connected to the boiler.

See Figure 57 to set your Outdoor Reset Curve.

To check the CH Target Temperature while using Outdoor Temperature Mode, press the  button while the boiler is operational and the display panel is powered on.

I. 0-10 Volt Input

1. A signal from a building management system may be connected to the boiler to enable remote control. This signal should be a 0-10 volt positive-going DC signal. When the 0-10V input is wired to the boiler terminal strip, a building control system can be used to control the set point temperature of the boiler. The control interprets the 0-10 volt signal as follows; when the signal is between 0 and 1.5 volts, the boiler will be in standby mode, not firing. When the signal rises above 1.5 volts, the boiler will ignite. As the signal continues to rise towards its maximum of 10 volts, the boiler will increase in set point temperature.

2. Connect a building management system or other auxiliary control signal to the terminals marked for this purpose on the boiler terminal block (shown in Piping Diagrams, this manual). Caution should be used to ensure that the 0-10VOLT + connection does not become connected to ground.

NOTE: Ensure that the polarity of the connections from the external modulating boiler controller to the boiler is correct. Reversed polarity could lead to erratic and/or no response from the boiler controller.

NOTE: Outdoor Temperature Mode Icon on the display will flash if an Outdoor Sensor or 0-10 Volt is not connected to the boiler.

0-10 V INPUT TABLE:

When outside voltage is applied to the connector (2) in the wiring diagram,

1. The outdoor temperature sensor does not work.
2. The 0-10V symbol is displayed.
3. The heating temperature is automatically set according to the external voltage input.

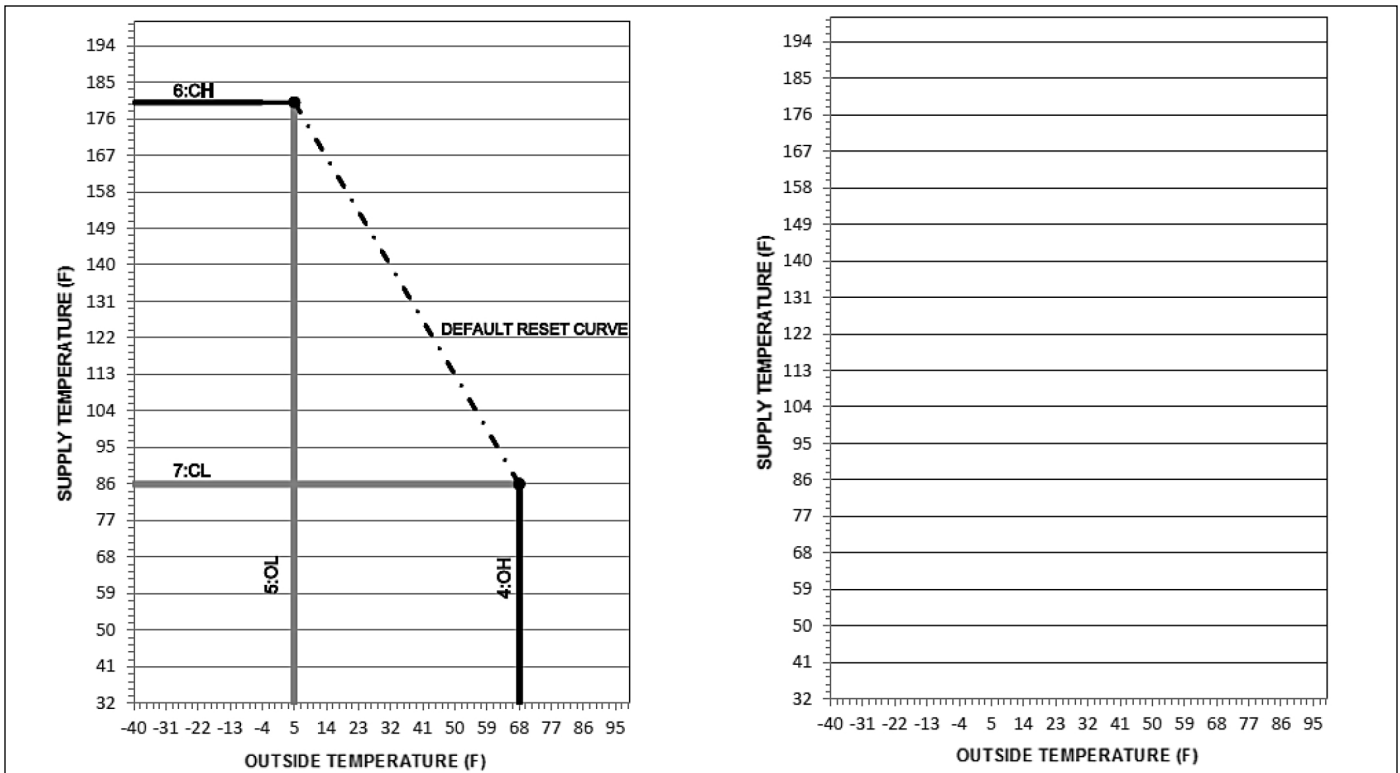

Figure 57 - Outdoor Reset Curve - See Installer Mode for Curve Setting Descriptions

NOTE: 0-10V is prioritized over Aquastat/Sensor. If input voltage is less than 1.5V then Aquastat/Sensor will operate. The range of input voltage is approximately 1.5[V] ~ 10[V] and the heating temperature settings according to this range are as follows.

Input voltage[V]	Heat temperature [°C]	Heat temperature [°F]
1.5	35.0	95
2.0	37.1	98.8
2.5	39.2	102.7
3.0	41.3	106.5
	...	
9.0	66.6	152
9.5	69	156.2
10	71.1	160

Table 29 - 0-10V Input Voltages and Associated Temperatures - NOTE: This example is for 0-10V CH Temperature when CL is 95°F and CH is 160°F. These numbers will change when CL or CH temperatures are set at different values.

CAUTION

Voltage exceeding 15V may damage internal parts. Such damages are not covered by product warranty.

J. Step Modulation

When the Step Modulation on/off parameter is active, step modulation limits the boiler firing rate when a heating cycle starts. There are six (6) limiting steps used to limit temperature overshoot and short cycles. See Figure 58. This feature can be turned on or off depending on the installation. This parameter can be changed by the installer by accessing parameter 37:CM or 38:dM. The control range of this parameter is OFF or ON. The default value is OFF. The percentage of each step can be decreased as low as 50% by decreasing the overall capacity of the boiler in the Installer Menu changing parameters 18:cb or 19:db.

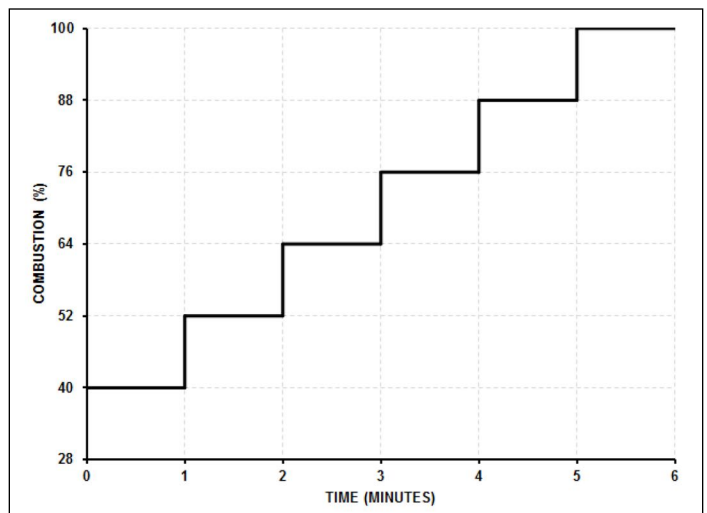

Figure 58 - Step Modulation

Part 10 - Troubleshooting

A. Error Code

When the boiler encounters an error, the display will flash "Er" followed by a numerical code. The boiler shall enter a soft lockout condition if the error is such that it can return to normal operation once the condition relieves itself (overheat conditions, NTC open or shorts, etc.). The boiler shall enter a hard lockout if the condition indicates something more serious (flame, ignition, condensate line, etc.) To clear a hard lockout Error Code, press the Power button. See Figure 59.

The following screen will display when the boiler encounters an error.

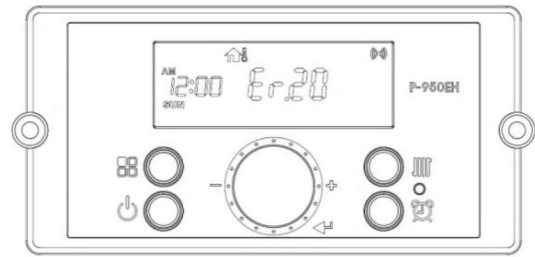

Figure 59 - Error Screen

Error Code	Error Code Description	Possible Remedies
Er:10	Flame has extinguished 5 (five) times	<p>Press the Power button to clear the Error Code. The Code will also automatically reset after one hour (up to three (3) times).</p> <p>If Error happens again:</p> <ol style="list-style-type: none"> 1. Monitor the gas pressure to the boiler while in operation. Ensure pressure is between 3.5 and 14"WC. 2. Check gas valve wire. Ensure connection is secure. 3. Check flame detection sensor. Ensure connections are secure. Normal operating settings are more than 2.5DC before ignition, less than 2.5DC after ignition. 4. Check vent terminations. Ensure there are no blockages. 5. Assure that the flame is stable when lit. 6. If the problem persists, replace the main control.
Er:11	Ignition has failed 5 (five) times	<p>Press the Power button to clear the Error Code. The Code will also automatically reset after one hour (up to three (3) times).</p> <p>If Error happens again:</p> <ol style="list-style-type: none"> 1. Monitor the gas pressure to the boiler while in operation. Ensure pressure is between 3.5 and 14"WC. 2. Check gas valve wire. Ensure connection is secure. 3. Check flame detection sensor. Ensure connections are secure. Normal operating settings are more than 2.5DC before ignition, less than 2.5DC after ignition. 4. Check igniter transformer for proper connection. 5. Clean the spark igniter with steel wool to remove oxides. Ensure proper separation (3-4 mm). 6. Replace the spark igniter if damaged. 7. Assure that the flame is stable when lit. 8. If the problem persists, replace the main control.
Er:16	CH Supply Temperature Sensor Detects Water Temperature Greater than 200°F (93.3°C) - Auto Reset	<p>This over temperature safety error code provides protection for the heat exchanger from damage due to overheating. Er:16 displays when the temperature at the CH Supply Sensor measures 200°F, which will shut down the burner and run the fan and pumps to cool the heat exchanger. The boiler will automatically restart once the temperature falls below 192°F and the programmed target setpoint. If the temperature reaches 210°F while Er:16 is displayed, the boiler will require a manual reset at the display.</p> <p>If Error happens again:</p> <ol style="list-style-type: none"> 1. Check if dip switch High Fire setting is ON. Switches 6 and 7 should be OFF for normal operation. 2. Check if CH inlet pipe is blocked. Ensure there is enough water flowing to the boiler. 3. Check CH sensor at CH outlet. If resistance is zero, replace the sensor. 4. Check Operating Temperature sensor at the heat exchanger. If resistance is zero, replace the sensor. 5. If the problem persists, replace the main control. <p>NOTE: During the error state, the pump will operate to cool the boiler until the temperature is below 192°F.</p>
	CH Supply Temperature Sensor Detects Water Temperature Greater than 210°F (98.8°C) - Manual Reset	
Er:20	Condensate - Closed is Normal, Open is Fault (Condensate Drain Trap)	<p>Press the Power button to clear the Error Code.</p> <ol style="list-style-type: none"> 1. Check Condensate and main controller connections. Ensure all are secure. 2. Check Condensate resistance. If resistance is not zero, replace the switch. 3. Check Condensate hose. Ensure it is connected and in good condition. 4. Check condensate line and termination for blockages. 5. Check exhaust vent for blockages. 6. If the problem persists, replace the main control.
Er:28	Overheat Sensor Open or Short	<p>This Error Code will go away when CH temperature decreases.</p> <p>If Error happens again:</p> <ol style="list-style-type: none"> 1. Check overheat temperature sensor. Ensure connections are secure. 2. Check overheat sensor resistance. If resistance is zero, replace the sensor. 3. If the problem persists, replace the main control.
Er:29	APS - Closed is Normal, Open is Fault	<p>Press the Power button to clear the Error Code.</p> <ol style="list-style-type: none"> 1. Check APS and main controller connections. Ensure all are secure. 2. Check APS resistance. If resistance is not zero, replace the switch. 3. Check APS hose. Ensure it is connected and in good condition. 4. Check condensate line and termination for blockages. 5. Check exhaust vent for blockages. 6. If the problem persists, replace the main control.

Error Code	Error Code Description	Possible Remedies
Er:30	System Sensor Fault	<p>NOTE: This error will only appear if the boiler is used in a cascaded system. This Error Code will go away when system sensor is repaired or replaced.</p> <ol style="list-style-type: none"> 1. Check system temperature sensor. Ensure connections are secure. 2. Check system sensor resistance. If resistance is zero, replace the sensor. 3. If the problem persists, replace the main control. <p>NOTE: During the error state the units will continue to operate. Boiler setpoint will be the same as the system sensor setpoint until the issue is remedied. During normal operation boiler setpoint is defaulted to 20°F higher than the system setpoint to a maximum of 180°F setting.</p>
Er:31	Return Temperature Sensor Open or Short	<p>This Error Code will go away when operating temperature decreases.</p> <p>If Error happens again:</p> <ol style="list-style-type: none"> 1. Check return temperature sensor. Ensure connections are secure. 2. Check return sensor resistance. If resistance is zero, replace the sensor. 3. If the problem persists, replace the main control.
Er:32	DHW Sensor Short	<p>NOTE: This error will only appear if an aquastat is installed and SEnS is selected in Installer Mode 39, or a sensor is used and it is shorted.</p> <p>This Error Code will go away if an aquastat is installed, AquA is selected in Installer Mode 39, and the boiler is powered OFF and ON, or the DHW sensor is repaired or replaced.</p> <ol style="list-style-type: none"> 1. Check DHW sensor. If an aquastat, ensure AquA is selected in Installer Mode 39. If a sensor, ensure connections are secure. 2. Check DHW sensor resistance. If resistance is zero or does not match that in Table 33, replace the sensor. 3. After completing steps 1 and 2, power the boiler OFF. Then turn it back ON. 4. If the problem persists, replace the main control.
Er:33	CH Temperature Sensor Open or Short	<p>This Error Code will go away when CH temperature decreases.</p> <p>If Error happens again:</p> <ol style="list-style-type: none"> 1. Check CH temperature sensor. Ensure connections are secure. 2. Check sensor resistance. If resistance is zero, replace the sensor. 3. If the problem persists, replace the main control.
Er:35	Exhaust Sensor Open or Short	<p>This Error Code will go away when exhaust temperature decreases.</p> <p>If Error happens again:</p> <ol style="list-style-type: none"> 1. Check exhaust temperature sensor. Ensure connections are secure. 2. Check sensor resistance. If resistance is zero, replace the sensor. 3. Check exhaust vent for blockage. 4. If the problem persists, replace the main control.
Er:37	Abnormal Supply Frequency	<p>Supply frequency is too high to operate. This Error Code will go away when supply frequency returns to normal operating range.</p> <p>If Error happens again:</p> <ol style="list-style-type: none"> 1. Ensure boiler is properly wired to a power source meeting the requirements on the rating plate. 2. If problem persists, replace the main control.
Er:38	Error Appears When Control Stores Data, but Data is not Saved	<p>Press the Power button to clear the Error Code.</p> <p>Replace the main control.</p>
Er:41	Fan Speed too high with flame on	<p>The Error Code will go away unless it occurs five (5) times in ten (10) minutes. Press the Power button to clear the Error Code.</p> <p>If Error happens again:</p> <ol style="list-style-type: none"> 1. Check the vent connections for blockages. 2. Check the burner assembly. 3. Check fan operation. If fan appears to be operating normally but RPMs are too low or too high, replace the fan. 4. If the problem persists, replace the main control.
Er:42	Low Water Cut-Off circuit is open	<p>Press the Power button to clear the Error Code.</p> <p>If Error happens again:</p> <ol style="list-style-type: none"> 1. Ensure that the LWCO jumper is installed if low water cut off is not use. 2. Ensure that the water LWCO wires are properly installed (if in use). 3. Ensure that the LWCO ground wire is properly grounded. 4. If the problem persists, replace the main control.
Er:43	Burner overheat switch open	<p>Press the Power button to clear the Error Code.</p> <p>If Error happens again:</p> <ol style="list-style-type: none"> 1. Check burner overheat switch connections. Ensure connections are secure. 2. Check switch resistance. If resistance is not zero, replace the switch. 3. If the problem persists, replace the main control. <p>NOTE: During the error state, the fan will operate to cool the burner until the switch closes.</p>
Er:61	Fan Speed Feedback Signal Abnormal	<p>This Error Code will go away when the condition is remedied.</p> <p>If Error happens again:</p> <ol style="list-style-type: none"> 1. Check the connections to the fan. Ensure all are secure. 2. If the fan does not rotate during the ignition sequence, check for 8Vac 26.5Vac power at the fan connection. If 8Vac 26.5Vac power is present at the control, replace the fan. If the blower does not have 8Vac 26.5Vac power, check power at the control. If 8Vac 26.5Vac power is not present at the control, replace the control. 3. If the problem persists, replace the main control.

Error Code	Error Code Description	Possible Remedies
Er:70	Register, Ram, Rom, I/O Port, AD Abnormal, Important EPROM Data or Safe Data Abnormal	This Error Code will go away when the condition is remedied. If Error happens again: 1. Turn power OFF and ON at the main power switch internal to the boiler. 2. If the problem persists, replace the main control.
Er:72	Flame Signal Detected before Ignition	This Error Code will go away when the condition is remedied. If Error happens again: 1. Check the boiler cover. Ensure it is secure. Flame detection sensor can detect an external light source. 2. Check flame detection sensor. Ensure connections are secure. Normal operating settings are more than 2.5DC before ignition, less than 2.5DC after ignition. 3. If the problem persists, replace the main control.
Er:76	Poor Communication	This Error Code will go away when the condition is remedied. If Error happens again: 1. Check connections from main control to display panel (error occurs if there is no communication for ten [10] minutes). 2. If the problem persists, replace the display and/or the main control.
Er:77	Outdoor Sensor Shorted	The Error Code will go away when the condition is remedied. If Error happens again: 1. Check outdoor sensor. Ensure all wiring connections are intact and secure. If the sensor wires were secured to the wall with staples, the wires may have been damaged. 2. Check outdoor sensor resistance. If resistance is zero, replace the sensor. 3. If the problem persists, replace the outdoor sensor. NOTE: When this error occurs, the boiler will still operate at the max setting of the Outdoor Reset Curve.
Er:78	Cascade Communication Error	NOTE: This error will only appear in a cascaded system. 1. Turn power OFF and ON at the boiler display panel. 2. If error reappears, ensure all cascaded boilers are powered ON. 3. If error reappears, check Installer Mode parameter 28 at the Master boiler. Ensure the number of cascaded units chosen in this parameter matches the number of cascaded units in the system. 4. If error reappears, check Installer Mode parameter 27 at all cascaded boilers. Ensure the address number matches that of the connected boiler (00 for Master, 01 for Follower 1, etc.) and that no numbers are skipped or repeated. 5. Ensure every unit in the cascade system is connected properly. Inspect the cascade cables and ensure all are connected without damage or defect. Repair or replace any damaged cables. 6. If the problem persists, replace the main control.
Er:80	Low Water Level Sensor (Low Water Level Detected four [4] Consecutive Times)	This Error Code will go away when the condition is remedied. If Error happens again: 1. Ensure all valves are open to the boiler and there are no leaks. 2. Ensure all air has been purged from the system. 3. Check wiring connections to low water level sensor. Ensure all are secure. 4. Check low water level sensor resistance. If resistance is zero, replace the sensor. 5. If the problem persists, replace the main control.
Er:81	Low Water Level Circuit	This Error Code will go away when the condition is remedied. If Error happens again: 1. Ensure the system is filled with water. Ensure all valves are open to the boiler and there are no leaks. 2. Check wiring connections to low water level sensor. Ensure all are secure. 3. Check low water level sensor resistance. If resistance is zero, replace the sensor. 4. If the problem persists, replace the main control.
Er:85	Freeze Protection (Boiler has detected water temperature below 34°F [1°C])	This Error Code will go away when the freezing condition is remedied. If Error happens again: 1. Ensure boiler is located in a mechanical room protected from freezing conditions. 2. Ensure all valves are open to the boiler, there are no leaks. 2. Check wiring connections to low water level sensor. Ensure all are secure. 3. Check low water level sensor resistance. If resistance is zero, replace the sensor. 4. If the problem persists, replace the main control.
Er:94	Exhaust NTC detects Vent Temperature is Greater than 190°F (88°C)	This Error Code will go away when the condition is remedied. If Error happens again: 1. Check if dip switch High Fire setting is ON. Switches 6 and 7 should be OFF for normal operation. 2. Check exhaust temperature sensor. Ensure connections are secure. 3. Check sensor resistance. If resistance is zero, replace the sensor. 4. Check exhaust vent for blockage. 5. If the problem persists, replace the control. 6. If the problem persists, replace the heat exchanger.

Table 30 - Error Codes and Suggested Corrective Actions

WARNING

This boiler is equipped with a blocked vent shutoff system. If Error Codes Er:29, Er:41, Er: 42, or Er:94 occur, turn off the gas valve at the manual shutoff. Check the vent terminations for obstructions. If no obstructions are found, reset the boiler by pressing the power button. If the error continues to occur, call a qualified service technician or the gas supplier to check the boiler. Failure to follow these instructions could result in property damage, personal injury, or death.

B. Error Tree Analysis
1. Flame Detection

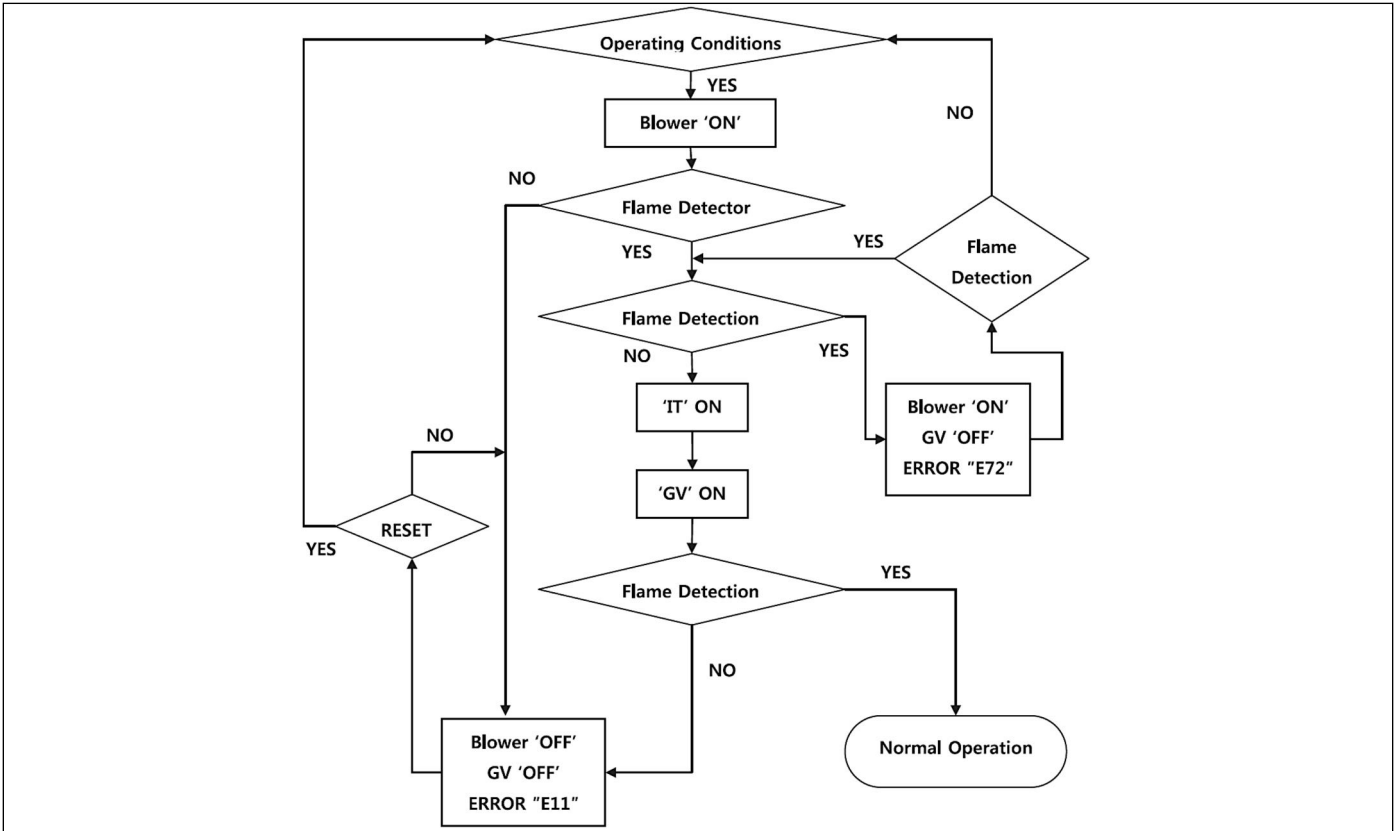

Figure 60 - Flame Detection Error Analysis Tree

2. Air Pressure Switch / Burner Overheat Limit / Condensate Block Switch

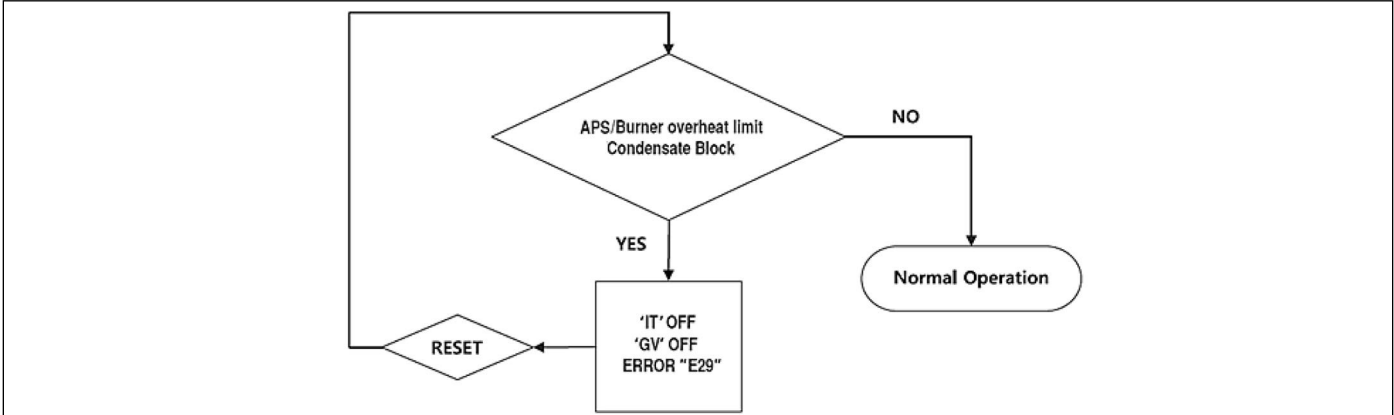

Figure 61 - APS / Burner Overheat Limit / Condensate Block Switch Error Analysis Tree

3. Storage / Operating Temperature / CH Overheat / Exhaust Sensors

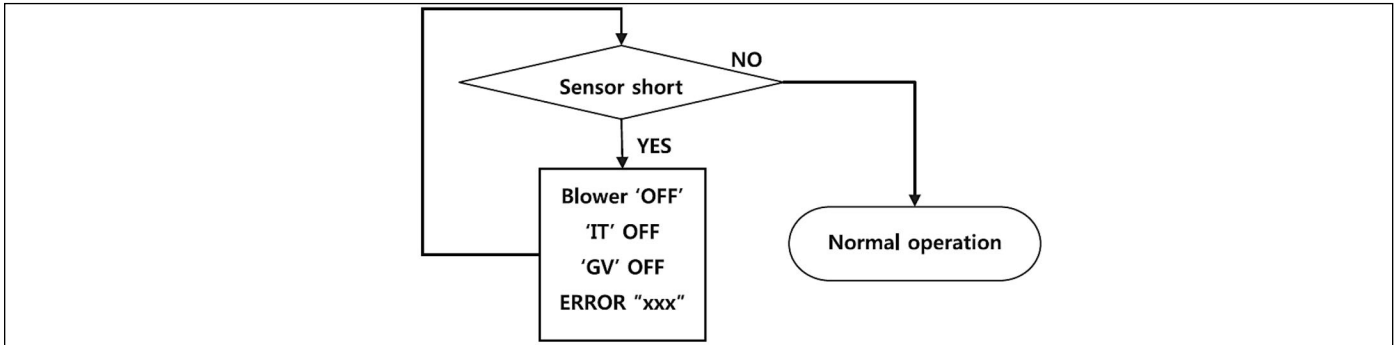

Figure 62 - Storage / Operating Temperature / CH Overheat / Exhaust Sensors Error Analysis Tree

C. Suggested Corrective Actions

Problem	Possible Causes	Possible Remedies
No electrical power to the boiler	<ol style="list-style-type: none"> 1. Is the plug on the power supply cord unplugged from the electrical outlet? 2. Is electrical panel's 10 Amp circuit breaker tripped? 3. Is the fuse on the circuit board good? 4. Is there a power outage to the home? 	<ol style="list-style-type: none"> 1. Reset the plug. 2. Reset the circuit breaker. 3. If the display panel is blank, unplug the unit or contact an authorized service technician. 4. Contact the power company.
House is not heating up	Is the CH temperature set too low?	Adjust the temperature setting.
Domestic hot water is too hot or not hot enough	Is the indirect water temperature set too high or low?	Adjust the temperature setting.
A fan can be heard even when the unit is not operating	<ol style="list-style-type: none"> 1. The fan continues to operate after the burner shuts off to clear the exhaust vent of combustion gases. 2. The fan may run to help prevent freezing. 	<ol style="list-style-type: none"> 1. This is normal operation – no action is required. 2. Protect the boiler from freezing temperatures or shut off and drain the unit.
White "smoke" can be seen coming out of the exterior exhaust gas vent	Depending on the outside temperature, water vapor can be produced as the exhaust is vented.	This is normal operation – no action is required.

Table 31 - Troubleshooting Chart

DIAGNOSTICS AND SUGGESTED CORRECTIVE ACTIONS

The boiler control is able to record information about the boiler's condition at the time of the ten previous faults or errors. This information is available to view in the Installer Mode under the History screen.

The following screens may be displayed when reviewing the boiler history. The table below also includes diagnostic information and possible corrective actions.

Display	Condition	Diagnostic	Possible Corrective Actions
Nothing appears on the display control panel but the fan runs at full speed	Control is not receiving power	Check wiring for short circuit or incorrect wiring	Correct wiring per wiring diagram including connection of transformer to the control.
		Check transformer connection to the control per wiring diagram. Check for 12V output of panel wire.	Push the Power button on the control panel. Replace transformer if it is receiving 120V, but not outputting 12 VAC.
Nothing appears on the display control panel and no other boiler components are operating	Control is not receiving 120V power	Ensure service switch and/or circuit breaker to boiler is turned ON	Turn on service switch or circuit breaker to power boiler
		Is there 120V at the service switch	Troubleshoot and correct the power supply to the manual switch
		Is the ON/OFF switch inside the boiler cabinet is turned on	Turn ON the manual power switch inside the boiler cabinet
		Check for 120V at the line voltage terminal block located inside the boiler cabinet	Correct wiring inside the boiler cabinet using the wiring diagram in the installation manual
		Inspect the fuse. Replace as necessary	Replace the fuse with the proper part found in the replacement part section of this manual. If fuse blows again, recheck the wiring per diagram
Nothing appears on the display control panel, but the boiler is operating	Occurs when communication is lost from the control to the display	Check for loose connections and proper pin alignment / engagement on the control's plug	Check for continuity on the wire harness from the display to the control. See repair parts section for proper replacement part.
		Cycle power off and on using boiler power switch and check for operation	Replace with new display module. See repair parts section for proper replacement part.
Display repeatedly goes through initialization sequence	Occurs when control does not receive signal from fan	Cycle power off and on using appliance power switch and check for operation	Replace fan

Table 32 - Diagnostics and Suggested Corrective Actions

CH Return Temperature Sensor (7855P-097) Exhaust Temperature Sensor (7850P-070)		CH Supply Temperature Sensor (7855P-030)		Outdoor Temperature Sensor (7855P-084)		Indirect Tank Sensor (7250P-325)	
Temperature (°F)	Resistance (Ω)	Temperature (°F)	Resistance (Ω)	Temperature (°F)	Resistance (Ω)	Temperature (°F)	Resistance (Ω)
-4	62162	-4	28409	-4	99200	32	32624
5	48440	5	22152	5	74229	41	25381
14	38045	14	17408	14	56090	50	19897
23	30107	23	13782	23	42790	59	15711
32	23998	32	10990	32	32930	68	12493
41	19261	41	8824	41	25550	77	10000
50	15562	50	7131	50	19990	86	8056
59	12655	59	5800	59	15760	95	6530
68	10353	68	4747	68	12510	104	5324
77	8520	77	3906	77	10000	113	4365
86	7051	86	3233	86	8050	122	3599
95	5867	95	2690	95	6520	131	2982
104	4908	104	2250	104	5310	140	2483
113	4125	113	1891	113	4350	149	2079
122	3485	122	1598	122	3590	158	1748
131	2957	131	1356			167	1476
140	2520	140	1155			176	1252
149	2157	149	989			185	1066
158	1854	158	850			194	912
167	1600	167	733			203	782
176	1386	176	635			212	674
185	1205	185	552				
194	1051	194	482				
203	920	203	421				
212	808	212	370				

Table 33 - Temperature Sensor Resistance

Part 11 - Start-Up

CAUTION

Thoroughly clean and flush any system that has used glycol before installing the boiler. Provide the customer with a material safety data sheet (MSDS) on the fluid used.

A. Check / Control Water Chemistry

CAUTION

Chemical imbalance of the water supply may affect efficiency and cause severe damage to the appliance and associated equipment. It is important that the water chemistry on both the domestic hot water and central heating sides are checked before installing the appliance. Water quality must be professionally analyzed to determine whether it is necessary to treat the water. Various solutions are available to adjust water quality. Adverse water quality will affect the reliability of the system. In addition, operating temperatures above 135°F will accelerate the build-up of lime scale and possibly shorten appliance service life. Failure of an appliance due to lime scale build-up, low pH, or other chemical imbalance IS NOT covered by the warranty.

To ensure extended service life, it is recommended to test water quality prior to installation. Listed below are some guidelines.

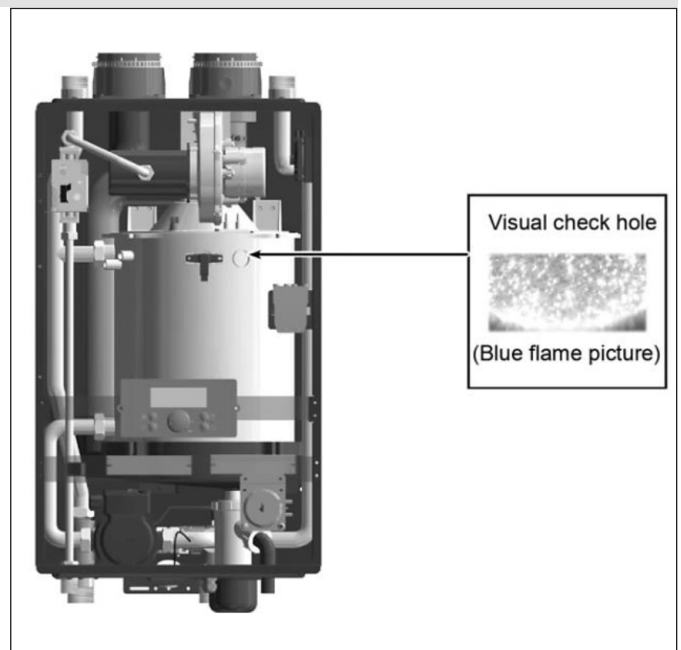

Figure 63 - Flame Sight Glass

CAUTION

Do not use petroleum-based cleaning or sealing compounds in the boiler system. Damage to elastomer seals and gaskets in the system could occur, resulting in substantial property damage.

Closed loop water must be free of corrosive chemicals, sand, dirt, and other contaminants. It is up to the installer to ensure the water does not contain corrosive chemicals or elements that can damage the heat exchanger.

If you suspect that your water is contaminated in any way, discontinue use of the appliance and contact an authorized technician or licensed professional.

Contaminant	Maximum Allowable Level
Total Hardness (Above 140°F water temperature)	120 mg/l (7 grains/gallon)
Aluminum	0.05 to 0.2 mg/l or PPM
Chloride	100 mg/l or PPM
Copper	1 mg/l or PPM
Iron	0.3 mg/l or PPM
Manganese	0.05 mg/l or PPM
pH	6.5 - 8.5
Sulfate	205 mg/l or PPM
Total Dissolved Solids (TDS)	500 mg/l or PPM
Zinc	5 mg/l or PPM
Dissolved Carbon Dioxide (CO ₂)	15 mg/l or PPM

Table 34 - Water Quality Specifications

***NOTE:** It is recommended to clean the heat exchanger at least once a year to prevent lime scale buildup. To clean the heat exchanger, follow the maintenance procedure in this manual.

Clean system to remove sediment*

1. You must thoroughly flush the system (without boiler connected) to remove sediment. The high-efficiency heat exchanger can be damaged by buildup or corrosion due to sediment.
2. For zoned systems, flush each zone separately through a purge valve. (If purge valves and isolation valves are not already installed, install them to properly clean the system.)
3. Check return Y strainer (if installed). Remove and clean sediment and debris if necessary.
4. Flush system until water runs clean and you are sure piping is free of sediment.

NOTE: Boiler failure due to improper water chemistry is not covered by warranty.

B. Check for Gas Leaks**WARNING**

Before starting the boiler, and during initial operation, smell near the floor and around the boiler for gas odorant or any unusual odor. Remove boiler front door and smell interior of boiler enclosure. Do not proceed with startup if there is any indication of a gas leak. Repair any leaks at once.

PROPANE BOILERS ONLY – The propane supplier mixes an odorant with the propane to make its presence detectable. In some instances the odorant can fade, and the gas may no longer have an odor. Before startup (and periodically thereafter), have the propane supplier verify the correct odorant level in the gas.

WARNING

If you discover any evidence of a gas leak, shut down the boiler at once. Find the leak source with a bubble test and repair immediately. Do not start the boiler again until the leak is repaired. Failure to comply could result in substantial property damage, severe personal injury, or death.

C. Freeze Protection (When Used)**WARNING**

NEVER use automotive or standard glycol antifreeze. Do not use ethylene glycol made for hydronic systems. Use only freeze-protection fluids certified by fluid manufacturer as suitable for use with stainless steel boilers, verified in the fluid manufacturer's literature. Thoroughly clean and flush any system that has used glycol before installing the new boiler. Provide the boiler owner with a material safety data sheet (MSDS) on the fluid used.

1. Determine the freeze protection fluid quantity using total system water content following the fluid manufacturer's instructions. Remember to include expansion tank water content.
2. Local codes may require back flow preventer or actual disconnect from city water supply.
3. When using freeze protection fluid with automatic fill, install a water meter to monitor water makeup. Freeze protection fluid may leak before the water begins to leak, causing concentration to drop, reducing the freeze protection level.
4. Glycol in hydronic applications should include inhibitors that prevent the glycol from attacking metallic system components. Make certain that the system fluid is checked for the correct glycol concentration and inhibitor level.
5. The glycol solution should be tested at least once a year or as recommended by the glycol manufacturer.
6. Anti-freeze solutions expand more than water. For example: A 50% by volume solution expands 4.8% in volume for a temperature increase from 32 - 80°F, while water expands 3% over the same temperature rise. Allowances must be made in system design for expansion.
7. A 30% mixture of glycol will result in a BTU output loss of 15% with a 5% increase in head against the system circulator.
8. A 50% mixture of glycol will result in a BTU output loss of 30% with a 50% increase in head against the system circulator.

CAUTION

It is highly recommended to carefully follow the glycol manufacturer's recommended concentrations, expansion requirements, and maintenance recommendations (pH additive breakdown, inhibitor reduction, etc.) You must carefully calculate the additional friction loss in the system as well as the reduction in heat transfer coefficients.

D. Fill and Test Water System**WARNING**

Ensure the boiler is full of water before firing the burner. Failure to do so will damage the boiler. Such damage IS NOT covered by warranty, and could result in property damage, severe personal injury, or death.

1. Fill the system only after ensuring water chemistry meets the requirements listed in this manual.
2. Close the manual and automatic air vents and boiler drain valve.
3. Fill to the correct system pressure. Correct pressure will vary with each application.
 - a. Typical cold water fill pressure for a residential system is 12 psi.
 - b. Pressure will rise when boiler is turned on and system water temperature increases. Operating pressure must never exceed the relief valve pressure setting.

4. At initial fill and during boiler startup and testing, check system thoroughly for leaks. Repair all leaks before proceeding further.

⚠ WARNING

Eliminate all system leaks. Continual fresh make-up water will reduce boiler life. Minerals can build up in the heat exchanger, reducing heat transfer, overheating the heat exchanger and causing heat exchanger failure.

5. The system may have residual substances that could affect water chemistry. After the system has been filled and leak tested, verify that water pH and chloride concentrations are acceptable by sample testing.















CAUTION

It is important to purge the system of air to avoid damage to the boiler.

E. Purge Air from Water System

CAUTION

IMPORTANT! While commissioning the system, the air vent on top of the boiler must remain fully open to allow the boiler to properly fill. Failure to keep the air vent open could lead to improper boiler and system operation.

1. Purge air from the system:
 - a. Connect a hose to the purge valve and route hose to an area where water can drain and be seen.
 - b. Close the boiler or system isolation valve between the purge valve and fill connection to the system.
 - c. Close zone isolation valves.
 - d. Open quick-fill valve on cold water make-up line.
 - e. Open purge valve.
 - f. Open the isolation valves one zone at a time. Allow water to run through the zone, pushing out the air. Run water until no noticeable air flow is present. Close the zone isolation valves and proceed with the next zone. Follow this procedure until all zones are purged.
 - g. Close the quick-fill water valve and purge valve and remove the hose. Open all isolation valves. Watch the system pressure rise to correct cold-fill pressure. It is recommended that you put the pumps into manual operation to assist in purging the circuits.
 - h. Disconnect the wires that are connected to the THERMOSTAT terminals of the terminal block. Apply power to the boiler. After the control goes through the start-up sequence, the display will turn off.
 - i. Press and hold the  button for five seconds. Then scroll to 34:AP by turning the dial . Press the  button. AP:cP will show on the display. Press the  button to change the test time. The default is five minutes. Turn the dial  counterclockwise to lower or clockwise to raise the displayed value. Press the  button again to save any changes.
 - j. Then use the dial  to scroll to cP1:off. Press the  button to turn on test mode. Turn the dial  counterclockwise to lower or clockwise to select on. Press the  button again to start test mode.
 - k. The boiler and CH system pumps will come on. Run pumps as required to help bleed out all entrapped air. Some good indicators that air is removed include the absence of gurgling noises in the pipes and pump operation becoming very quiet. Test mode will stop automatically after the set time (default is five minutes), or press the  button to leave it manually.
 - m. Then use the dial  to scroll to cP2:off. Press the  button to turn on test mode. Turn the dial  counterclockwise to lower or clockwise to select on. Press the  button again to start test

mode.

n. The DHW indirect pump will come on. Run pump as required to help bleed out all entrapped air. Some good indicators that air is removed include the absence of gurgling noises in the pipes and pump operation becoming very quiet. Test mode will stop automatically after the set time (default is five minutes), or press the  button to leave it manually.

o. After the system has operated for some time, eliminate any residual air by using the manual air vents located throughout the system.

p. If purge valves are not installed in the system, open manual air vents in the system one at a time, beginning with the lowest floor. Close vent when water squirts out. Repeat with remaining vents.

q. Refill to correct pressure.

F. Check Thermostat Circuit(s)

1. Disconnect the two external wires connected to the boiler thermostat terminals (low voltage terminal strip).
2. Connect a voltmeter across these two incoming wires with power supplied to the thermostat circuits. Close each thermostat, zone valve and relay in the external circuit one at a time and check the voltmeter reading across the incoming wires.
3. There should NEVER be a voltage reading.
4. If a voltage reading does occur under any condition, check and correct the external wiring. (This is a common problem when using 3-wire zone valves.)
5. Once the external thermostat circuit wiring is checked and corrected if necessary, reconnect the external thermostat circuit wires to the boiler low voltage terminal strip. Allow the boiler to cycle.

G. Condensate Removal

1. The boiler is a high efficiency condensing boiler. Therefore, the unit has a condensate drain. Condensate fluid is nothing more than water vapor, derived from combustion products, similar to that produced by an automobile when it is initially started. Condensation is slightly acidic (typically with a pH of 3 to 5) and must be piped with the correct materials. Never pipe the condensate using steel, copper, brass or other materials that will be subject to corrosion. Plastic PVC or CPVC pipe are the only approved materials. A condensate neutralizer, if required by local authorities, can be made up of lime crystals, marble or phosphate chips that will neutralize the condensate. This may be done by the installer or you may purchase a condensate neutralizer from HTP (7450P-212).
2. The boiler is equipped with a $\frac{3}{4}$ female socket weld fitting connection that must be piped to a local drain. It is very important that the condensate line is sloped downward away from the boiler to a suitable inside drain. If the condensate outlet on the appliance is lower than the drain, you must use a condensate removal pump, available from HTP (554200). This pump is equipped with two leads that can be connected to an alarm or another type of warning device to alert the user of a condensate overflow, which, if not corrected, could cause property damage.
3. If a long horizontal run is used, it may be necessary to create a vent in the horizontal run to prevent a vacuum lock in the condensate line.
4. Do not expose the condensate to freezing temperatures.
5. It is very important you support the condensation line to assure proper drainage.

Part 12 - Installation Checklist

Before Installing	Yes	No
Is there enough space to ensure proper installation?		
Does installation location allow for proper service clearances?		
Are water and gas lines properly sized and set at proper pressures for the installation?		
Is boiler location as near the exhaust vent / intake pipe terminations as possible?		
Have combustible materials been cleared from the installation location?		
Is there a drain close to the boiler?		
Water Piping	Yes	No
Does boiler loop piping meet the minimum sizing requirements listed? NOTE: Smaller piping will cause performance problems.		
Has water chemistry been checked?		
Does water chemistry meet requirements?		
If water chemistry does not meet requirements, have treatment measures been put in place?		
Has the system been cleaned and flushed?		
Install Exhaust Vent and Intake Piping	Yes	No
Has the boiler been vented with the approved materials listed in this manual or to meet local codes?		
Is air supply sufficient for proper boiler operation?		
Is total vent piping length within the maximum vent length restriction listed in this manual?		
Install Exhaust Vent and Intake Piping	Yes	No
Have venting lengths been minimized?		
Are terminations properly spaced from windows, doors, and other intake vents?		
Have all vent terminations been installed at least one foot above exterior grade and one foot above normal snow accumulation level?		
Is vent piping properly supported?		
Has vent piping been checked for leaks?		
Has the exhaust vent line been pitched back to the boiler at a rate of 1/4" per foot?		
Have the exhaust vent and intake pipes been properly installed to the boiler?		
Install Condensate Piping / Tubing and Components	Yes	No
Have all condensate components included with the boiler been installed?		
Is the condensate line piped with the approved materials listed in this manual?		
Has the condensate line been routed to a laundry tub or other drain?		
Install Gas Piping	Yes	No
Is the gas supply line a minimum of 3/4" in diameter?		
Is the gas supply line length and diameter adequate to deliver the required BTUs?		
Has gas supply line pressure been measured?		
Does the gas type match the type indicated on the boiler rating plate?		
Has a union and shut-off valve been installed?		
Relief Valve	Yes	No
Is the Pressure Relief Valve properly installed and discharge line run to open drain?		
Is the discharge line at least 3/4" in diameter and protected from freezing?		
Wiring	Yes	No
Has the power and control been wired per boiler wiring diagram, this manual?		
Have all DIP switches been set on the main boiler board?		
Is the electrical connection polarity within boiler requirements?		
Does the power supply voltage agree with the boiler rating plate? 120V AC?		

Start-Up, Adjust, and Test	Yes	No
Has the boiler been started?		
If necessary, has the boiler gas valve been adjusted?		
Has the installation been customized per installation location requirements?		
Have all customized system parameters been tested?		
Has proper boiler operation been confirmed?		
Burner Flame	Yes	No
Has the burner flame been checked?		
Have combustion values been verified with a calibrated combustion analyzer?		
If the flame does not appear normal, it may need to be cleaned by a qualified service technician. See Figure 63 for flame sight glass window location.		
Final Installation Approvals		
Signed by Technician	Date	

Table 35 - Installation Checklist

Part 13 - Maintenance

DANGER

The boiler must be inspected and serviced annually, preferably at the start of the heating season, by a qualified service technician. In addition, the maintenance and care of the boiler as outlined in this manual must be performed by the user/owner to assure maximum efficiency and reliability. Follow the maintenance procedures given throughout this manual. Failure to perform the service and maintenance or follow the directions in this manual could damage the boiler or system components, resulting in substantial property damage, severe personal injury, or death.

Check the Surrounding Area

DANGER

To prevent the potential of substantial property damage, severe personal injury, or death, eliminate all the materials listed in Table 6 from the area surrounding the boiler and the vicinity of the combustion air intake. If contaminants are found:

- Remove products immediately from area.
- If contaminants have been there for an extended period, call a qualified service technician to inspect the boiler for possible damage from acid corrosion.

If products cannot be removed, immediately call a qualified service technician to re-pipe the combustion air intake piping away from the contaminated areas.

Combustible/Flammable Materials

Do not store combustible materials, gasoline, or other flammable vapors or liquids near the boiler. If found, remove these materials immediately.

Air Contaminates

If allowed to contaminate combustion air, products containing chlorine or fluorine will produce acidic condensate that will cause significant damage to the boiler. Read the list of potential contaminants and areas likely to have these contaminants in Table 6. If any of these contaminants are in the room where the boiler is located, or combustion air is taken from one of the areas listed, the contaminants must be removed immediately or the intake pipe must be relocated to another area.

Ensure the Boiler Cabinet is Closed

Ensure the boiler cabinet is closed. Tighten the two upper and lower screws to secure it. The cabinet must be closed while the boiler is running.

Check the Power Source

Make sure the power cord is properly connected. The main power line is connected to the manual switch box inside the boiler.

Check the Status of the Control Panel

Observe the Control Panel to ensure the boiler is powered on, and to check for any error codes. Clear any debris from the panel.

Check Exhaust Vent and Intake Pipe Terminations

Verify that the boiler exhaust vent and intake pipe terminations are clean and free of obstructions. Remove any debris from the exhaust vent or intake pipe openings. If removing the debris does not allow the boiler to operate correctly, contact your qualified service technician to inspect the boiler and the vent system.

Check Exhaust Vent and Intake Piping

Visually inspect the exhaust vent for any signs of blockage, leakage, or deterioration of the piping. Inspect the exhaust vent bracing. Ensure bracing is undamaged and in good condition. Notify a qualified service technician immediately if any problems are found.

WARNING

Failure to inspect the venting system and have it repaired by a qualified service technician can result in vent system failure, causing severe personal injury or death.

Visually inspect the intake piping for any signs of blockage. Inspect the entire length of the intake pipe to ensure piping is intact and all joints are properly sealed. Inspect the intake pipe bracing. Ensure bracing is undamaged and in good condition. Notify a qualified service technician if any problems are found.

Check Pressure Relief Valve

- Visually inspect the primary pressure relief valve and discharge pipe for signs of weeping or leakage.
- If the pressure relief valve often weeps, the expansion tank may not be operating properly. Immediately contact a qualified service technician to inspect the boiler and system.

Check the Condensate Drain System

- While the boiler is running, check the discharge end of the condensate drain tubing. Ensure no flue gas is leaking from the condensate drain tubing by holding your fingers near the opening.
- If you notice flue gas leaking from the opening, this indicates a dry condensate drain trap. If problem persists, contact a qualified service technician to inspect the boiler and condensate line and refill the condensate trap.

- If applicable, check the condensate neutralizer and ensure it is full of condensate neutralizing marble chips.

Check Primary and Gas Piping

- Remove the boiler cover and perform a gas leak inspection following Operating Instructions, page 2, this manual. If gas odor or leak is detected, follow procedures on page 2. Call a qualified service technician.
- Visually inspect for leaks around the boiler water connections and around the heat exchanger. Visually inspect the external system piping, circulators, and system components and fittings. Immediately call a qualified service technician to repair any leaks

WARNING

Have leaks fixed at once by a qualified service technician. Failure to comply could result in substantial property damage, severe personal injury, or death.

Operate Pressure Relief Valve

- Before proceeding, verify that the relief valve outlet has been piped to a safe place of discharge, avoiding any possibility of scalding from hot water.
- Shut power off to the boiler. To avoid scalding, wait for boiler to cool before operating the relief valve.

WARNING

To avoid water damage or scalding due to relief valve operation, a discharge line must be connected to the valve outlet and directed to a safe place of disposal. This discharge line must be installed by a qualified service technician or heating/plumbing installer in accordance with the boiler installation manual. The discharge line must be terminated so as to eliminate possibility of severe burns or property damage should the valve discharge.

- Lift the relief valve lever. If water flows freely, release the lever and allow the valve to seat. Watch the end of the relief valve discharge pipe to ensure that the valve does not weep after the line has had time to drain. If the valve weeps, lift the lever again to attempt to clean the valve seat. If the valve does not properly seat and continues to weep, contact a qualified service technician to inspect the valve and system.
- If water does not flow from the valve when you completely lift the lever, the valve or discharge line may be blocked. Immediately shut the boiler down per instructions on page 2 and call a qualified service technician to inspect the valve and system.
- If relief valve seats properly, restore power to the boiler. Observe operation for five minutes and ensure it operates properly.

Check the Burner

Clean the exterior of the burner.

Flushing the Boiler

Flushing the heat exchanger is a complicated procedure that should only be performed by a qualified service technician.

NOTE: Improper maintenance WILL VOID boiler warranty.

1. Disconnect electrical power to the boiler.
2. Close the shutoff valves on both CH supply and return lines (V1 and V2). See Figure 64.
3. Connect one hose (D1, Figure 64) to the valve (V3) and place the free end in a bucket. Connect one of the hoses (D3) to the circulation pump outlet and the cold water inlet line to valve V4. Connect the other hose (D2) to the circulation pump inlet and place the free end in the bucket.

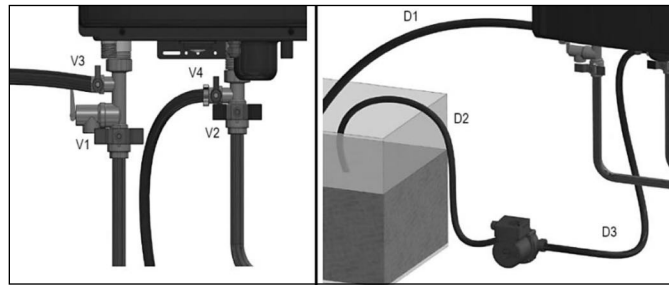

Figure 64 - Flushing the Boiler

4. Pour tankless boiler cleaning solution into the bucket. Ensure the cleaning solution is approved for potable water systems. Place the drain hose (D1) and hose D2 to the pump inlet in the cleaning solution.
5. Open service valves (V3 and V4) on the supply and return lines.
6. Turn on the pump. Operate the pump and allow the cleaning solution to circulate through the boiler for at least 1 hour at a rate of 4 gallons per minute. This will remove any possible harmful scale deposits.
7. Rinse the cleaning solution from the boiler as follows:
 - a. Remove the free end of drain hose D1 from the bucket.
 - b. Close service valve V4 and open shutoff valve V2.
 - c. Do not open shutoff valve V1.
 - d. Allow water to flow through the boiler for 5 minutes.
 - e. Close shutoff valve V2.
8. Disconnect all hoses.
9. Remove the cold water inlet filter from the boiler and clean out any residues.
10. Reinsert the filter and ensure the filter cap is securely tightened.
11. Connect electrical power to the boiler.
12. Open a hot water faucet. Run the boiler continuously for five minutes to ensure all cleaning solution is purged from the system. Check for leaks and ensure the boiler is operating properly.
13. Properly dispose of used cleaning solution.

Maintaining the Condensate System

⚠ DANGER

The condensate trap assembly **MUST BE PROPERLY INSTALLED** according to these instructions when operating the boiler. Operating the boiler without the condensate trap assembly will cause flue gases to leak and result in serious personal injury or death.

⚠ WARNING

When servicing is complete, make sure the condensate collector cap is replaced securely. Failure to do so will cause venting issues that will result in serious injury or death.

1. Ensure the boiler is powered off and has had time to cool.
2. Remove the hose clamp attaching the condensate trap to the condensate hose from the heat exchanger. Remove the clear plastic hose from the hose barb. Remove the condensate hose clamp to detach the condensate trap from the drain tube. Remove the condensate trap from the boiler.
3. Remove the bottom cap from the condensate trap.
4. Flush trap with fresh water to remove debris from the trap.

NOTE: Ensure the float moves freely within the trap. If the float does not move, **DO NOT** reinstall the trap.
5. When the condensate trap is sufficiently clean, reinstall the bottom cap on the trap.

NOTE: Ensure all parts shown in Figure 65, Condensate Detail, are installed with the condensate trap. If any parts are missing **DO NOT** reinstall the trap. Replace the entire assembly.

WARNING

Do not install the condensate assembly if a component is lost or missing. Replace the entire assembly. Failure to follow this warning could result in property damage, serious personal injury, or death.

6. Fill the condensate trap with fresh water prior to reassembly on the boiler.
7. Install the condensate trap on the condensate hose from the heat exchanger. Use the hose clamp to secure the trap. Attach the clear plastic hose onto the hose barb. Reinstall the condensate hose clamp to detach the condensate trap from the drain tube.

WARNING

Do not operate the boiler without the clear hose attached from the hose barb to the pressure switch. Failure to follow this warning could result in property damage, serious personal injury, or death.

8. If a condensate neutralizer kit is installed with the boiler, check the assembly when cleaning the condensate trap, and replenish the limestone chips if necessary. When replacing the limestone chips, take care to ensure chips are no smaller than 1/2" to avoid blockage in condensate piping (for piping details, refer to condensate neutralizer installation instruction.)
9. Check condensate piping for sagging and/or leakage. Repair any sags or leaks before restoring power to the boiler.

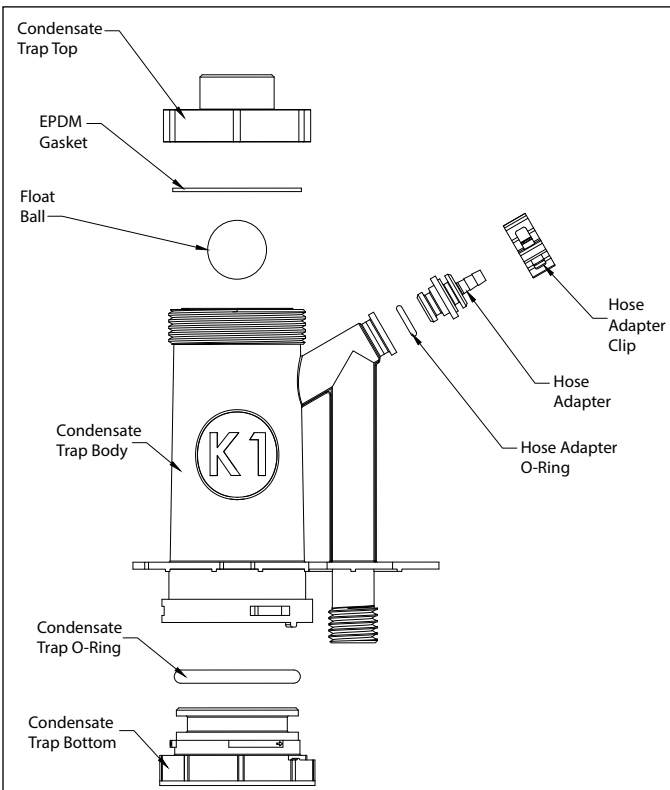

Figure 65 - Condensate Detail

CAUTION

It is very important that the condensate piping be no smaller than 3/4". To prevent sagging and maintain pitch, condensate piping should be supported with pipe supports, and pitched 1/4" per foot to allow for proper drainage.

The condensate line must remain unobstructed, allowing free flow of condensate. If condensate freezes in the line, or if line is obstructed in any other manner, condensate can exit from the tee, resulting in potential water damage to property.

10. If the boiler has a condensate pump, ensure the pump operates properly before considering maintenance complete.

Maintenance Report

CAUTION

In unusually dirty or dusty conditions, care must be taken to keep boiler cabinet door in place at all times. Failure to do so VOIDS WARRANTY!

WARNING

Allowing the boiler to operate with a dirty combustion chamber will hurt operation. Failure to clean the heat exchanger as needed by the installation location could result in boiler failure, property damage, personal injury, or death. Such product failures ARE NOT covered under warranty.

The combustion chamber insulation in this product contains ceramic fiber material. Ceramic fibers can be converted to cristobalite in very high temperature applications. The International Agency for Research on Cancer (IARC) has concluded, "Crystalline silica inhaled in the form of quartz or cristobalite from occupational sources is carcinogenic to humans (Group 1)."

- Avoid breathing dust and contact with skin and eyes.
- Use a NIOSH certified dust respirator (N95). This type of respirator is based on the OSHA requirements for cristobalite at the time this document was written. Other types of respirators may be needed depending on job site conditions. Current NIOSH recommendations can be found on the NIOSH website: <http://www.cdc.gov/niosh/homepage.html>. NIOSH approved respirators, manufacturers, and phone numbers are also listed on this website.
- Wear long-sleeved, loose fitting clothing, gloves, and eye protection.
- Apply enough water to the combustion chamber lining to prevent dust.
- Wash potentially contaminated clothes separately from other clothing. Rinse clothes washer thoroughly.

NIOSH stated First Aid.

- Eye: Irrigate immediately.
- Breathing: Fresh air.

The boiler requires minimal periodic maintenance under normal conditions. However, in unusually dirty or dusty conditions, periodic vacuuming of the cover to maintain visibility of the display and indicators is recommended.

Periodic maintenance should be performed once a year by a qualified service technician to assure that all the equipment is operating safely and efficiently. The owner should make necessary arrangements with a qualified heating contractor for periodic maintenance of the boiler. Installer must also inform the owner that the lack of proper care and maintenance of the boiler may result in a hazardous condition.

INSPECTION ACTIVITIES		DATE LAST COMPLETED			
PIPING		1 st YEAR	2 nd YEAR	3 rd YEAR	4 th YEAR*
Near boiler piping	Check boiler and system piping for any sign of leakage. Leaking pipes could cause property damage. Make sure all piping is properly supported. Flush tankless heat exchanger annually (more in hard water conditions). See User's Information manual for instructions.				
Vent	Check condition of all vent pipes and joints. Ensure all vent piping is properly supported. Check for obstructions exhaust and intake termination points.				
Gas	Check Gas piping, test for leaks and signs of aging. Make sure all pipes are properly supported.				
SYSTEM					
Visual	Do a full visual inspection of all system components.				
Functional	Test all functions of the system (Heat, Safeties)				
Temperatures	Verify safe settings on boiler or Anti-Scald Valve				
Temperatures	Verify programmed temperature settings				
ELECTRICAL					
Connections	Check wire connections. Make sure they are tight.				
Smoke and CO detector	Verify devices are installed and working properly. Change batteries if necessary.				
Circuit Breakers	Check to see that the circuit breaker is clearly labeled. Exercise circuit breaker.				
Switch and Plug	Verify ON/OFF switch and convenience plug are both functional				
CHAMBER/BURNER					
Combustion Chamber	Check burner tube and combustion chamber coils. Clean according to maintenance section of manual. Vacuum combustion chamber.				
Spark Electrode	Clean. Set gap at 1/8".				
CONDENSATE					
Condensate Trap	Clean debris from the condensate trap. Fill with clean water.				
Neutralizer	Check condensate neutralizer. Replace if necessary.				
Condensate hose	Disconnect condensate hose. Clean out dirt and re-install. (NOTE: Verify the flow of condensate, making sure that the hose is properly connected during final inspection.)				
GAS					
Pressure	Measure incoming gas pressure (3.5" to 14"W.C.)				
Pressure Drop	Measure drop in pressure on light off (no more than 1"W.C.)				
Check gas pipe for leaks	Check piping for leaks. Verify that all are properly supported.				
COMBUSTION					
CO/CO2 Levels	Check CO and CO2 levels in Exhaust. Record at high and low fire.				
SAFETIES					
ECO (Energy Cut Out)	Check continuity on Flue and Water ECO. Replace if corroded.				
FINAL INSPECTION					
Check list	Verify that you have completed entire check list. WARNING: FAILURE TO DO SO COULD RESULT IN SERIOUS INJURY OR DEATH.				
Homeowner	Review what you have done with the homeowner.				
TECH SIGN OFF					

Table 36 - *Continue annual maintenance beyond the 4th year as required.

Part 14 - Moving Adapters from Left to Right (Floor Models)

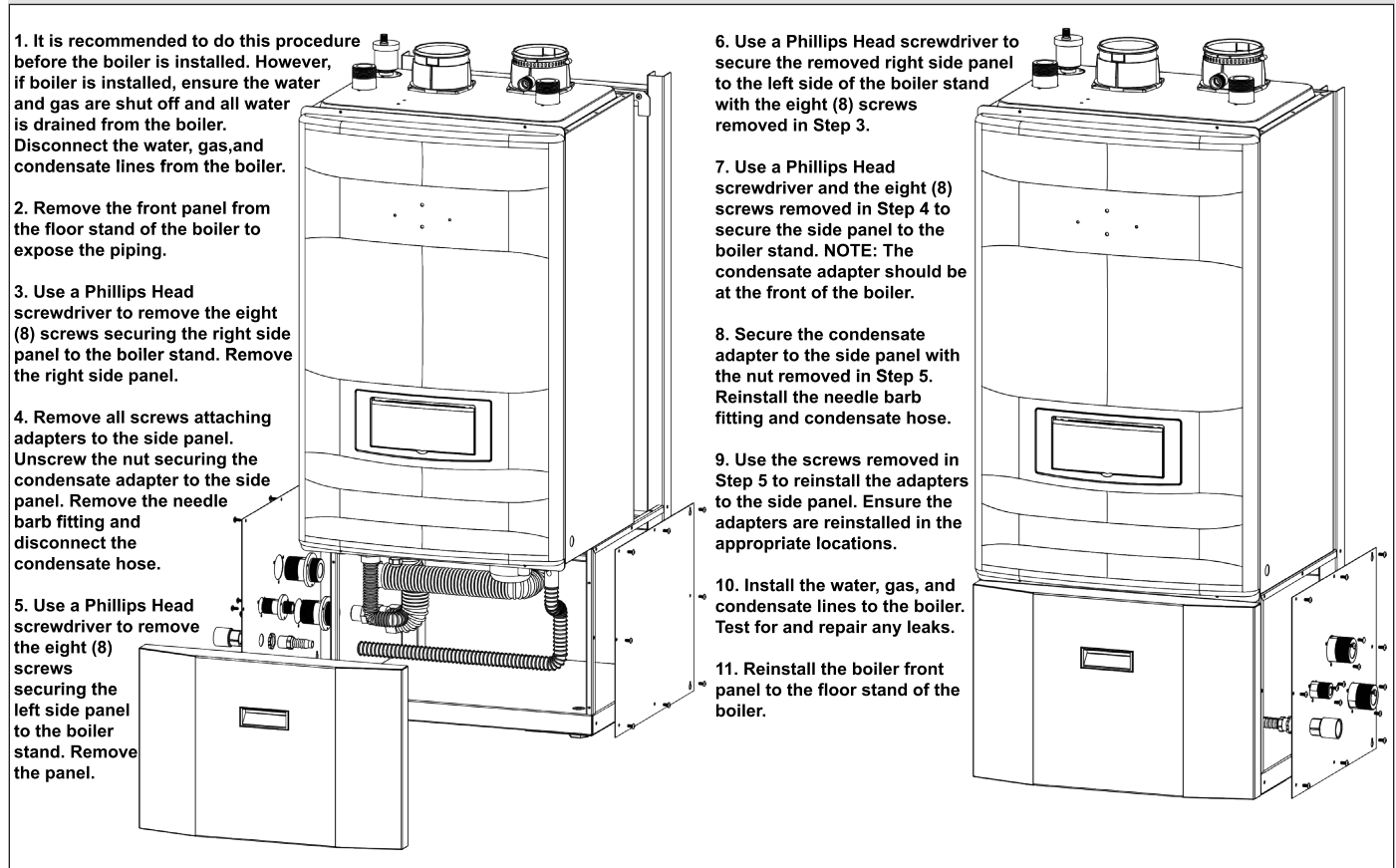

Figure 66 - Moving Adapters from Left to Right

Part 15 - Replacement Parts

NUMBER	DESCRIPTION	PART NUMBER	NUMBER	DESCRIPTION	PART NUMBER
B-1	M3 X 6 PH + M/S	7855P-384	B-10	M4 X 12 TH + M/S	7855P-393
B-2	M4 X 8 PH + Self Tapping	7855P-385	B-11	M4 X 14 PH + Self Tapping	7855P-394
B-3	M4 X 8 TH + Self Tapping	7855P-386	B-12	M4 X 15 PW + M/S	7855P-395
B-4	M4 X 8 TH + M/S	7855P-387	B-13	M4 X 20 TH + Self Tapping	7855P-396
B-5	M4 X 10 FH + M/S	7855P-388	B-14	M5 X 14 Flange Bolts + M/S	7855P-397
B-6	M4 X 10 TH + Self Tapping	7855P-389	B-15	M5 X 10 TH + M/S	7855P-453
B-7	M4 X 10 TH + M/S	7855P-390	B-26	M4 X 14 (S/W+P/W)	
B-8	M4 X 10 Flat Head	7855P-391	N-1	M4 Nut	7855P-398
B-9	M4 X 12 PH + M/S	7855P-392	N-2	M5 Nut	7855P-399

Table 37 - Replacement Bolts and Nuts - See Figures 67 - 74 for Where Used

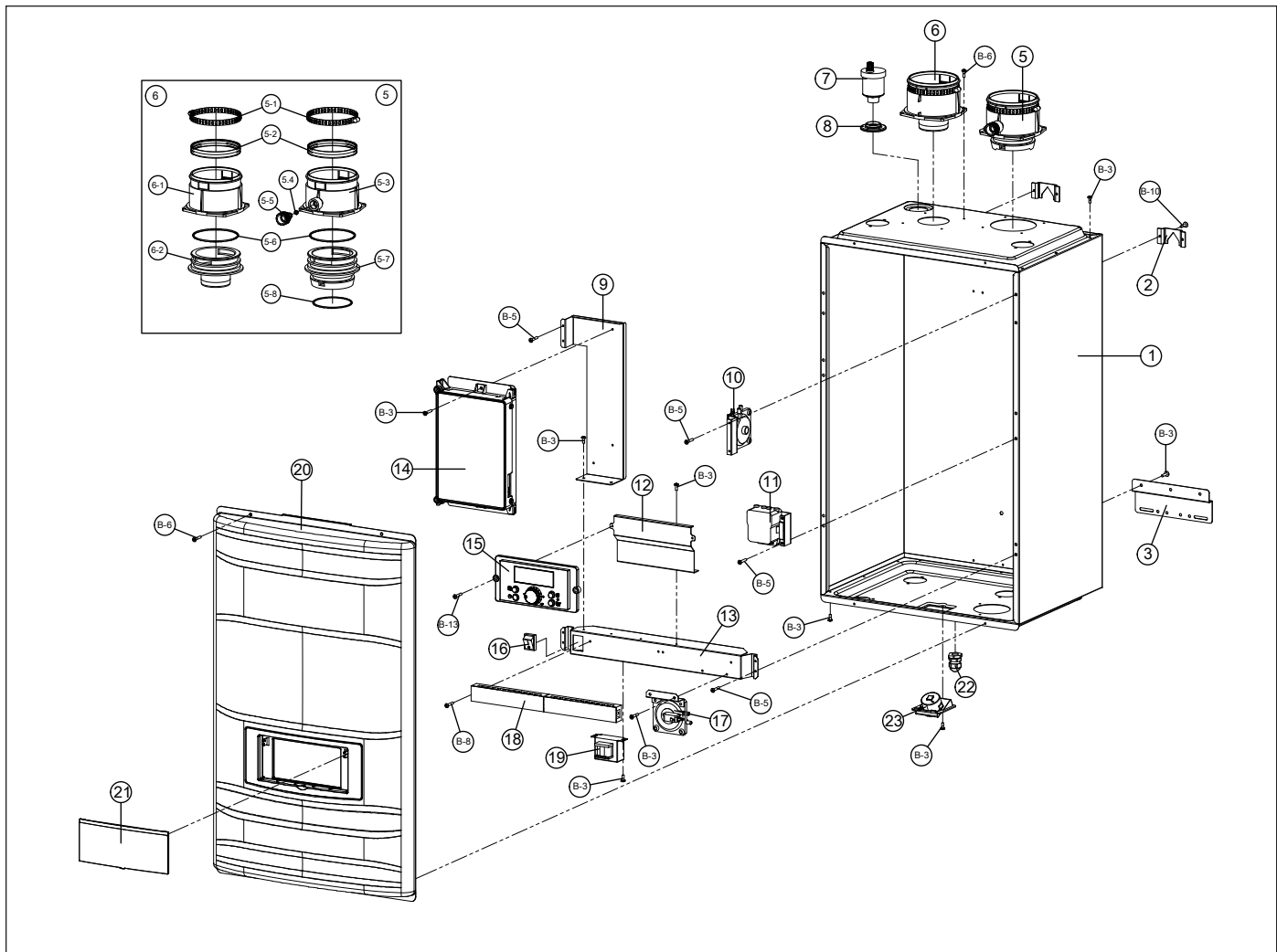
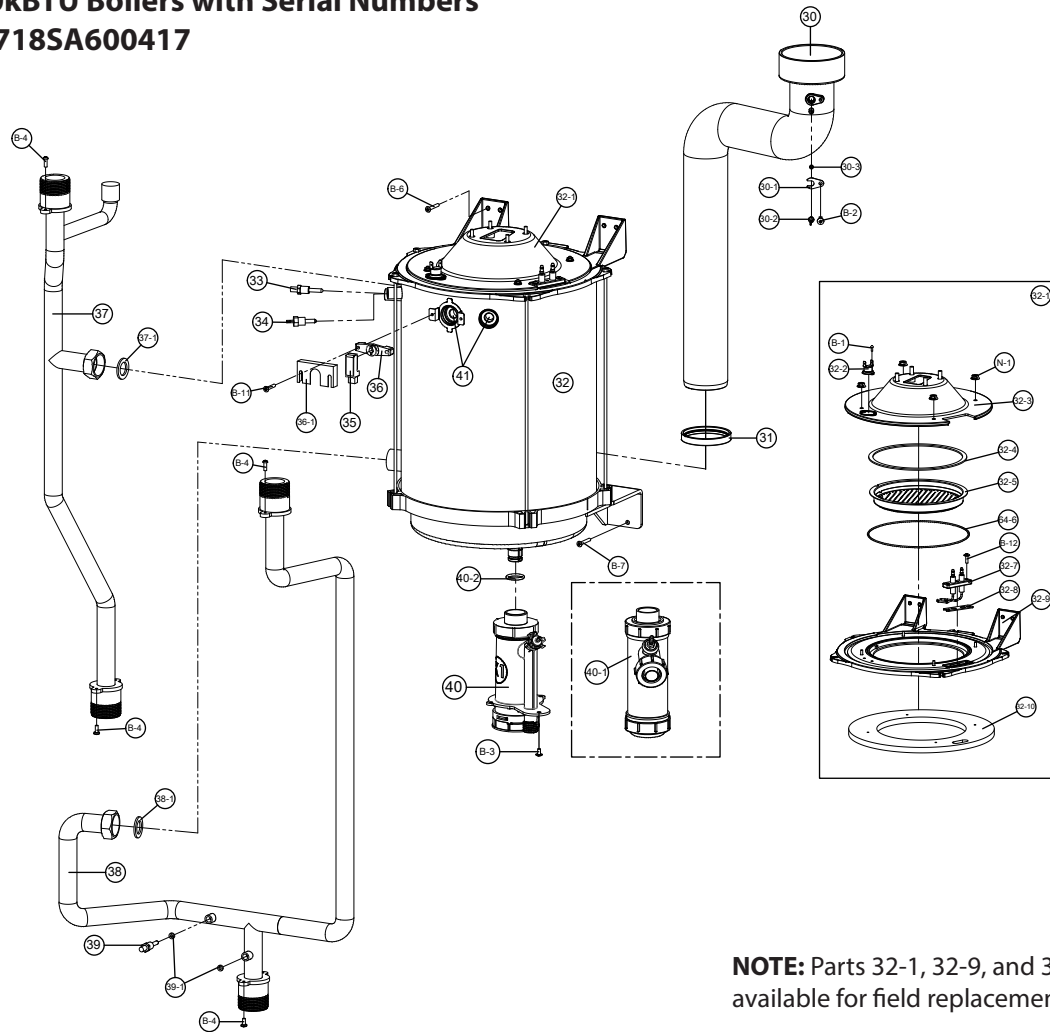

Figure 67 - Cabinet Replacement Parts - 80 - 140 Floor and Wall Mount Models

NUMBER	DESCRIPTION	PART NUMBER	NUMBER	DESCRIPTION	PART NUMBER
1	Cabinet Assembly	7855P-330	8	Air Vent Grommet	7855P-339
2	Top Wall Mount Bracket	7850P-068	9	Control Board Bracket	7855P-340
3	Bottom Wall Mount Bracket	7850P-092	10	Air Pressure Switch	7855P-262
4	N/A	N/A	11	Ignition Transformer	7855P-007
5	Exhaust Duct Assembly	7855P-002	12	Display Panel Bracket	7855P-341
5-1	Exhaust/Intake Duct Clamps (Φ100)	7855P-332	13	Terminal Blocks Bracket	7855P-342
5-2	Exhaust/Intake Gaskets	7850P-210	14	Control Board	80 7855P-308 100 7855P-309 120 7855P-310 140 7855P-311
5-3	Exhaust Duct	7855P-333	15	Display Panel	7855P-344
5-4	Combustion Analyzer Port Plug O-Ring	7855P-334	16	Manual Power Switch	7855P-014
5-5	Combustion Analyzer Port Plug	7855P-335	17	Condensate Block APS	7855P-017
5-6	Intake and Exhaust Adapter O-Ring (Φ85)	7855P-256	18	Terminal Block	7855P-345
5-7	Exhaust Duct Inner Adapter	7855P-004	19	Transformer	7855P-346
5-8	Exhaust Adapter O-Ring (Φ75)	7855P-254	20	Front Cover	7855P-347
6	Air Intake Cap Assembly	7855P-003	21	Display Panel Cover	7850P-023
6-1	Air Intake Cap	7855P-337	22	Wire Gland	7855P-348
6-2	Air Intake Inner Adapter	7855P-338	23	CH Pressure Gauge	7855P-222
7	Air Vent	7855P-063		Wire Harness (Not Shown)	7855P-468

Table 38 - Cabinet Replacement Parts - 80 - 140 Floor and Wall Mount Models

**For 80 - 140kBTU Boilers with Serial Numbers
Before 081718SA600417**



NOTE: Parts 32-1, 32-9, and 32-10 are not available for field replacement.

Figure 68 - Heat Exchanger Replacement Parts - 80 - 140 Floor and Wall Mount Models

NUMBER	DESCRIPTION	PART NUMBER	NUMBER	DESCRIPTION	PART NUMBER
30	Exhaust Pipe Assembly	7855P-237	33	CH Supply Temperature Sensor	7855P-030
30-1	Exhaust Temperature Sensor Clip	7855P-349	34	Water Level Detection Sensor (Low Water Cut-Off)	7855P-029
30-2	Exhaust Temperature Sensor	7855P-092	35	Flame Sensor	7855P-031
30-3	Exhaust Temperature Sensor O-Ring		36	Flame Sensor Bracket	7855P-356
31	Exhaust Pipe Gasket	7855P-351	36-1	Flame Sensor Cover	7855P-357
32	Heat Exchanger Assembly	80 / 100	37	CH Supply Pipe	80 / 100
		120 / 140			120 / 140
32-1	Burner Body Assembly	N/A	37-1	CH Supply Pipe Gasket	7855P-074
32-2	Burner Overheat Switch	7855P-066	38	CH Return Pipe	7855P-361
32-3	Burner Body	7855P-067	38-1	CH Return Pipe Gasket	7855P-074
32-4	Burner Gasket	7855P-266	39	CH Return Sensor	7855P-097
32-5	Ceramic Fiber Burner	7855P-069	39-1	CH Return Sensor Gasket	7855P-364
32-6	Burner Plate O-Ring	7855P-249	40	Condensate Trap Assembly (New Model)	7855P-605
32-7	Ignitor	7855P-068	40-1	Condensate Trap Assembly (Old Model)	7855P-053
32-8	Ignitor Gasket	7855P-252	40-2	O-Ring P22A	7855P-276
32-9	Heat Exchanger Top	N/A	41	Sight Glass	7855P-401
32-10	Burner Refractory	N/A			

Table 39 - Heat Exchanger Replacement Parts - 80 - 140 Floor and Wall Mount Models

For 80 - 140kBTU Boilers with Serial Number 081718SA600417 and After

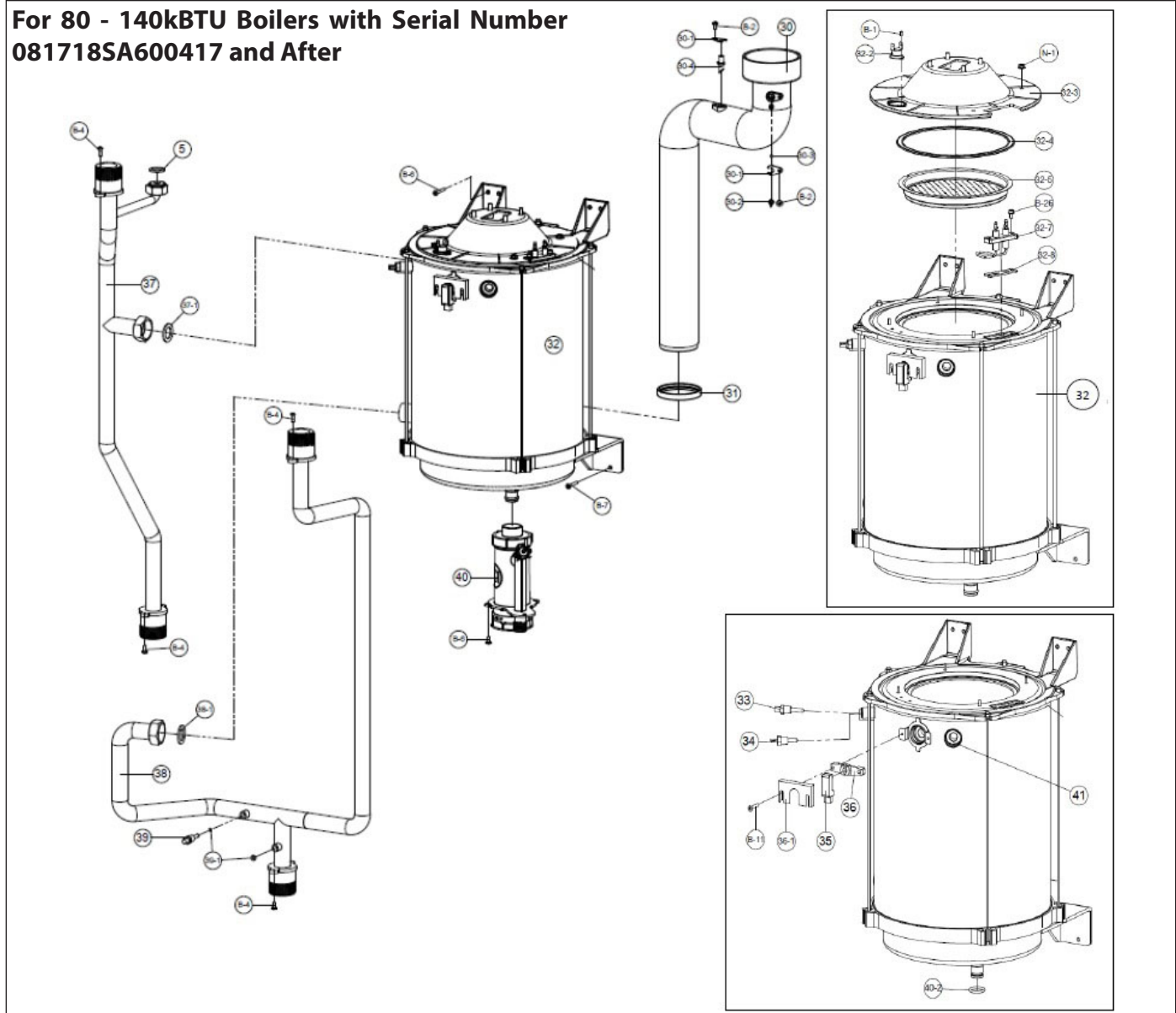

Figure 69 - Heat Exchanger Replacement Parts - 80 - 140 Floor and Wall Mount Models

NUMBER	DESCRIPTION	PART NUMBER	NUMBER	DESCRIPTION	PART NUMBER	
30	Exhaust Pipe Assembly	7855P-237	34	Water Level Detection Sensor (Low Water Cut-Off)	7855P-029	
30-1	Exhaust Temperature Sensor Clip	7855P-349	35	Flame Sensor	7855P-031	
30-2	Exhaust Temperature Sensor	7855P-092	36	Flame Sensor Bracket	7855P-356	
30-3	Exhaust Temperature Sensor O-Ring		36-1	Flame Sensor Cover	7855P-357	
30-4	Exhaust APS Hose Fitting	7855P-444	37	CH Supply Pipe	80 / 100	7855P-358
31	Exhaust Pipe Gasket	7855P-351			120 / 140	7855P-359
32	Heat Exchanger Assembly	80 / 100	7855P-352	37-1	CH Supply Pipe Gasket	7855P-074
		120 / 140	7855P-353	38	CH Return Pipe	7855P-361
32-2	Burner Overheat Switch	7855P-066	38-1	CH Return Pipe Gasket	7855P-074	
32-3	Burner Body	7855P-440	39	CH Return Sensor	7855P-097	
32-4	Burner Gasket	7855P-634	39-1	CH Return Sensor Gasket	7855P-364	
32-5	Ceramic Fiber Burner	7855P-069	40	Condensate Trap Assembly (New Model)	7855P-605	
32-7	Ignitor	7855P-068	40-1	Condensate Trap Assembly (Old Model)	7855P-053	
32-8	Igniter Gasket	7855P-252	40-2	Condensate Trap O-Ring P22A	7855P-276	
33	CH Supply Temperature Sensor	7855P-030	41	Sight Glass	7855P-401	

Table 40 - Heat Exchanger Replacement Parts - 80 - 140 Floor and Wall Mount Models

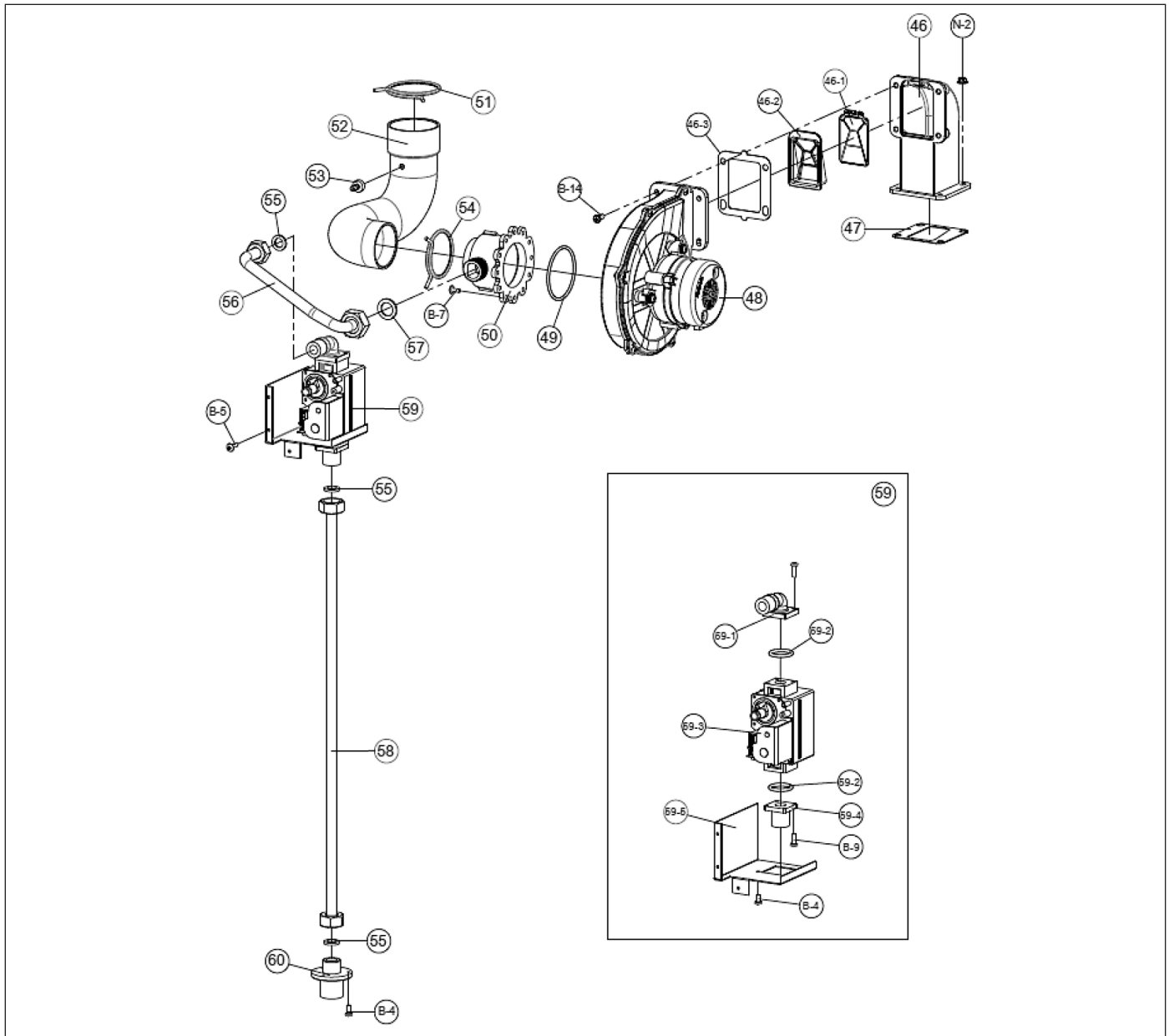

Figure 70 - Combustion System Replacement Parts - 80 - 140 Floor and Wall Mount Models

NUMBER	DESCRIPTION	PART NUMBER		NUMBER	DESCRIPTION	PART NUMBER	
46	Burner Inlet Channel (with Damper)	7855P-367		53	APS Hose Fitting	7855P-375	
46-1	Air Damper	7855P-368		54	Mixer Clamp	7855P-376	
46-2	Air Damper Guide	7855P-369		55	1/2" Gas Pipe Gasket	7855P-221	
46-3	Fan Outlet Gasket	7855P-425		56	Gas Pipe (to Mixer)	80 / 100	7855P-377
47	Burner Inlet Channel Gasket	7855P-370				120 / 140	7855P-378
48	Fan	7855P-025		57	3/4" Gas Pipe Gasket	7855P-379	
49	Fan O-Ring	7855P-371		58	Gas Pipe (to Gas Valve)	7855P-380	
50	Mixer	Model	NG	LP	59	Gas Valve Assembly	7855P-381
		80	7855P-300	7855P-301	59-1	Gas Valve Outlet Adapter	7855P-232
		100	7855P-302	7855P-303	59-2	Gas Valve O-Ring	7855P-076
		120	7855P-316	7855P-305	59-3	Gas Valve	7855P-034
		140	7855P-317	7855P-307	59-4	Gas Valve Inlet Adapter	7855P-033
51	Air Intake Hose Clamp	7855P-372		59-5	Gas Valve Bracket	7855P-234	
52	Air Intake Hose	80 / 100	7855P-373		60	Gas Inlet Adapter (3/4")	7855P-382
		120 / 140	7855P-374				

Table 41 - Combustion System Replacement Parts - 80 - 140 Floor and Wall Mount Models

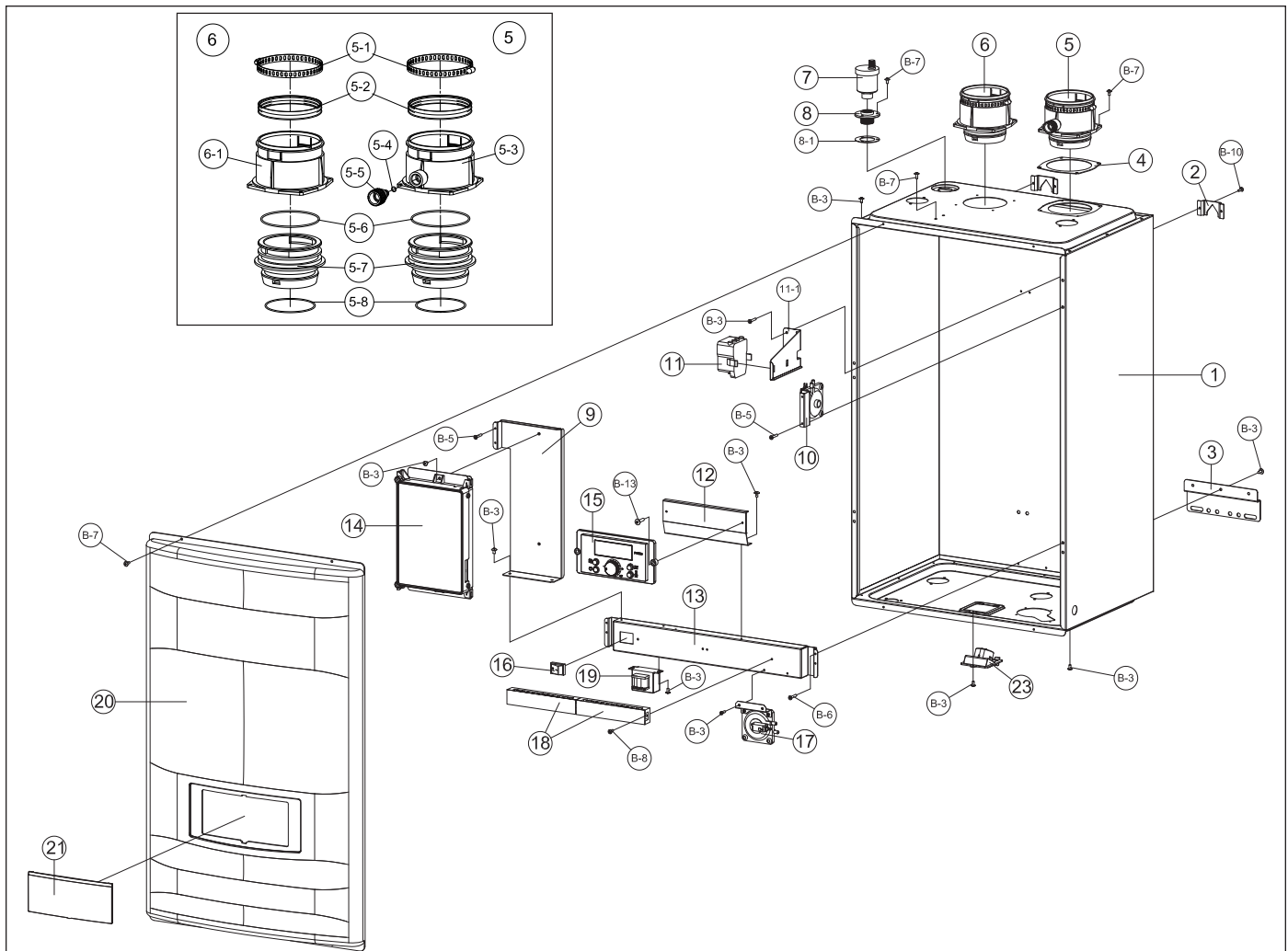

Figure 71 - Cabinet Replacement Parts - 175 - 199 Floor and Wall Mount Models

NUMBER	DESCRIPTION	PART NUMBER	NUMBER	DESCRIPTION	PART NUMBER
1	Cabinet Assembly	7855P-445	8-1	Air Vent Grommet	7855P-339
2	Top Wall Mount Bracket	7850P-068	9	Control Board Bracket	7855P-412
3	Bottom Wall Mount Bracket	7850P-092	10	Air Pressure Switch	7855P-262
4	Exhaust Adapter Sealing Gasket	7850P-041	11	Ignition Transformer	7850P-271
5	Exhaust Duct Assembly	7855P-002	11-1	Ignition Transformer Bracket	7855P-441
5-1	Exhaust/Intake Duct Clamps (Φ100)	7855P-332	12	Display Panel Bracket	7855P-413
5-2	Exhaust/Intake Gaskets	7850P-210	13	Terminal Blocks Bracket	7855P-434
5-3	Exhaust Duct	7855P-333	14	Control Board	175 7855P-404
					199 7855P-405
5-4	Combustion Analyzer Port Plug O-Ring	7855P-334	15	Display Panel	7855P-344
5-5	Combustion Analyzer Port Plug	7855P-335	16	Manual Power Switch	7855P-014
5-6	Intake and Exhaust Adapter O-Ring (Φ85)	7855P-256	17	Condensate Block APS	7855P-017
5-7	Exhaust Duct Inner Adapter	7855P-004	18	Terminal Block	7855P-345
5-8	Exhaust Adapter O-Ring (Φ75)	7855P-254	19	Transformer	7855P-346
6	Air Intake Assembly	7855P-411	20	Front Cover	7855P-414
6-1	Air Intake Cap	7855P-337	21	Display Panel Cover	7850P-023
6-2	Air Intake Inner Adapter	7855P-004	22	Wire Gland	7855P-348
7	Air Vent	7855P-063	23	CH Pressure Gauge	7855P-222
8	Air Vent Adapter	7855P-454		Wire Harness (Not Shown)	7855P-469

Table 42 - Cabinet Replacement Parts - 175 - 199 Floor and Wall Mount Models

For 175 - 199kBTU Boilers with Serial Numbers Before 082918SA900531

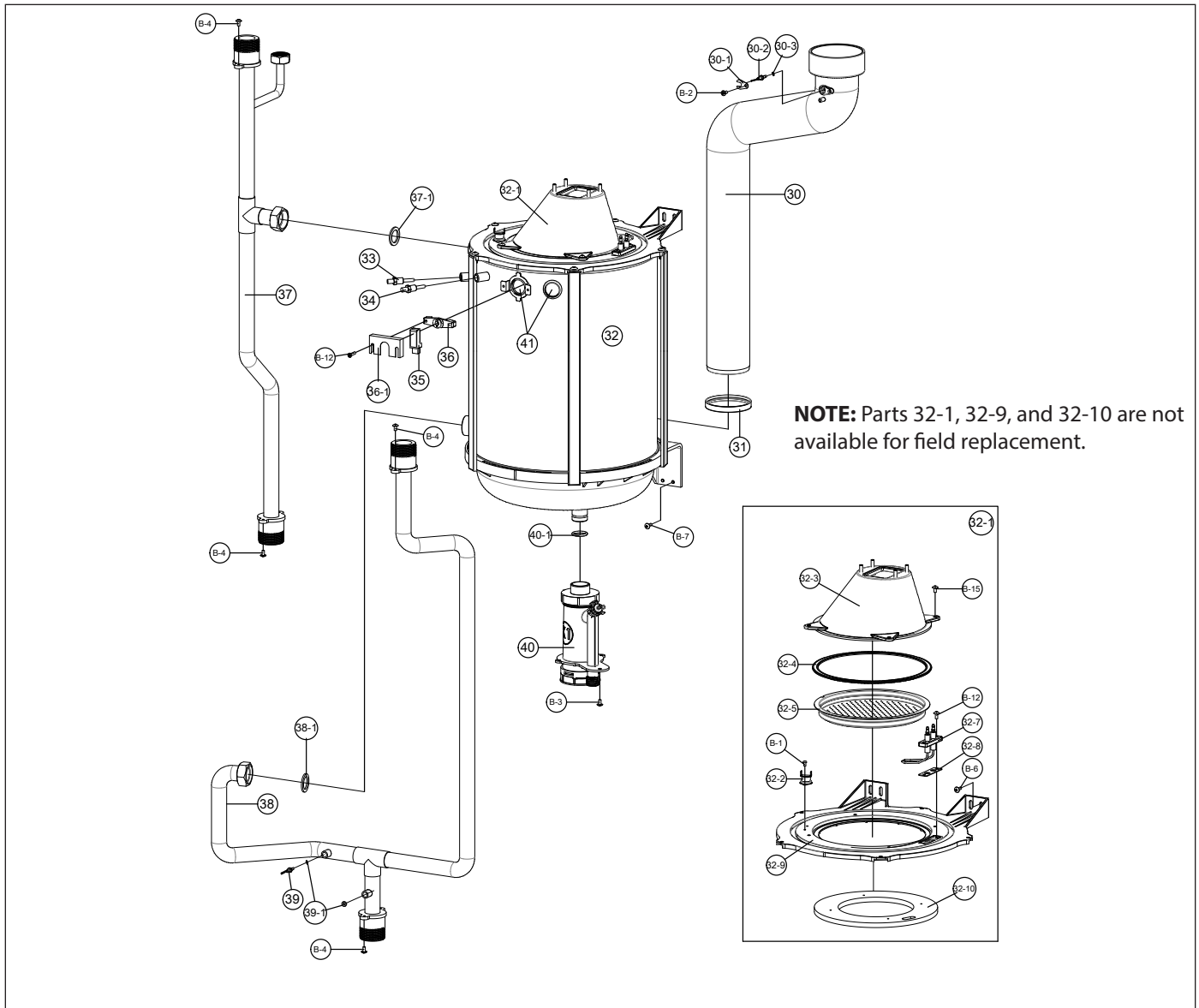

Figure 72 - Heat Exchanger Replacement Parts - 175 - 199 Floor and Wall Mount Models

NUMBER	DESCRIPTION	PART NUMBER	NUMBER	DESCRIPTION	PART NUMBER
30	Exhaust Pipe Assembly	7855P-415	32-10	Burner Refractory	N/A
30-1	Exhaust Temperature Sensor Clip	7855P-349	33	CH Supply Temperature Sensor	7855P-030
30-2	Exhaust Temperature Sensor	7855P-092	34	Water Level Detection Sensor (Low Water Cut-Off)	7855P-029
30-3	Exhaust Temperature Sensor O-Ring		35	Flame Sensor	7855P-031
31	Exhaust Pipe Gasket	7855P-418	36	Flame Sensor Bracket	7855P-356
32	Heat Exchanger Assembly	7855P-416	36-1	Flame Sensor Cover	7855P-357
32-1	Burner Body Assembly	N/A	37	CH Supply Pipe	7855P-421
32-2	Burner Overheat Switch	7855P-066	37-1	CH Supply Pipe Gasket	7855P-074
32-3	Burner Body	7855P-606	38	CH Return Pipe	7855P-422
32-4	Burner Gasket	7855P-419	38-1	CH Return Pipe Gasket	7855P-074
32-5	Ceramic Fiber Burner	7855P-420	39	CH Return Sensor	7855P-097
32-6	Burner Plate O-Ring	7855P-249	39-1	CH Return Sensor Gasket	7855P-364
32-7	Ignitor	7855P-607	40	Condensate Trap Assembly	7855P-605
32-8	Ignitor Gasket	7855P-252	40-1	O-Ring P22A	7855P-276
32-9	Heat Exchanger Top	N/A	41	Sight Glass	7855P-401

Table 43 - Heat Exchanger Replacement Parts - 175 - 199 Floor and Wall Mount Models

For 175 - 199kBTU Boilers with Serial Number 082918SA900531 and After

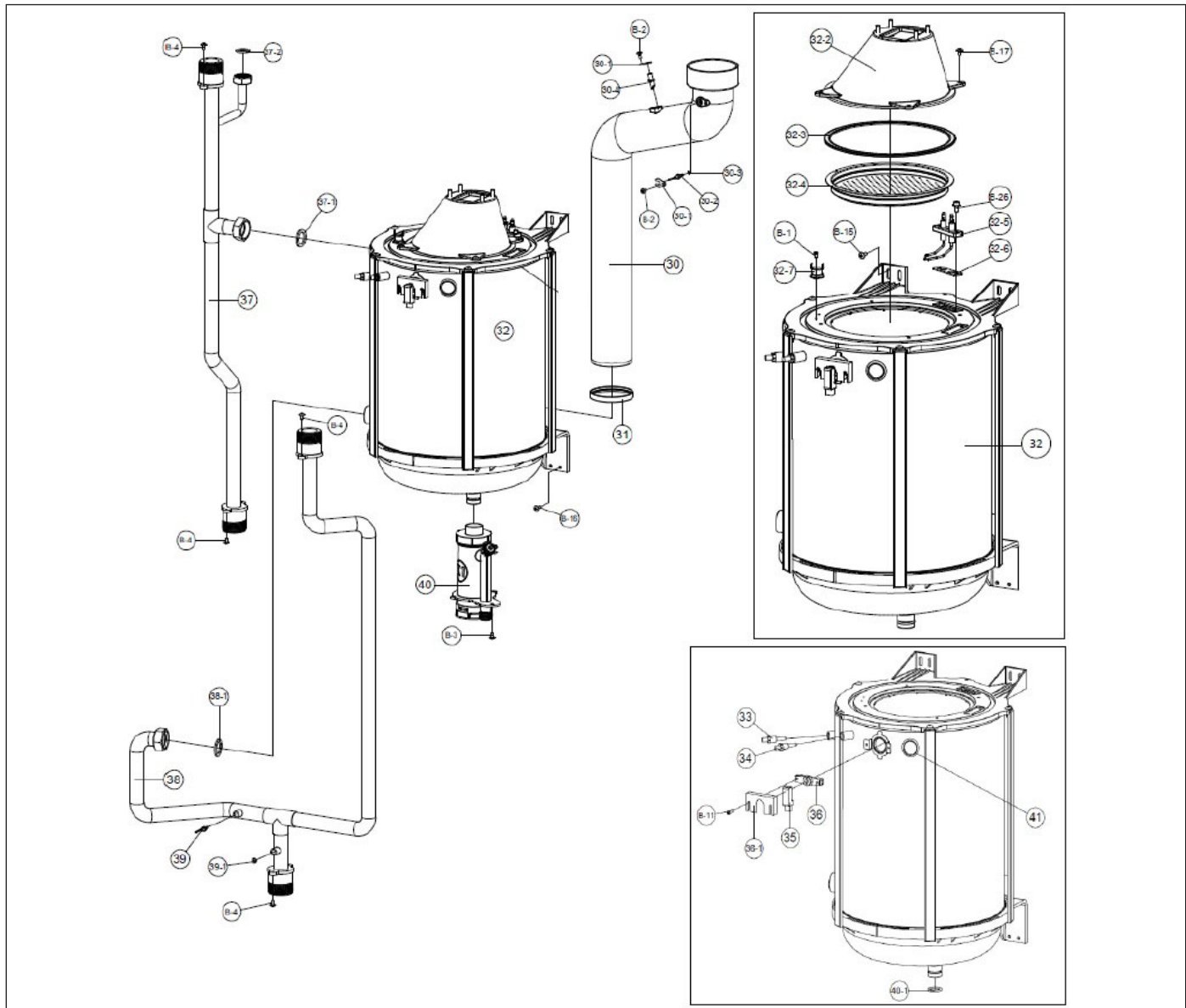

Figure 73 - Heat Exchanger Replacement Parts - 175 - 199 Floor and Wall Mount Models

NUMBER	DESCRIPTION	PART NUMBER	NUMBER	DESCRIPTION	PART NUMBER
30	Exhaust Pipe Assembly	7855P-415	34	Water Level Detection Sensor (Low Water Cut-Off)	7855P-029
30-1	Exhaust Temperature Sensor Clip	7855P-349	35	Flame Sensor	7855P-031
30-2	Exhaust Temperature Sensor	7855P-092	36	Flame Sensor Bracket	7855P-356
30-3	Exhaust Temperature Sensor O-Ring		36-1	Flame Sensor Cover	7855P-357
30-4?	Exhaust APS Hose Fitting	7855P-444	37	CH Supply Pipe	7855P-421
31	Exhaust Pipe Gasket	7855P-418	37-1	CH Supply Pipe Gasket	7855P-074
32	Heat Exchanger Assembly	7855P-416	37-2	3/4" Pipe Gasket	7855P-073
32-1	Burner Assembly	7855P-442	38	CH Return Pipe	7855P-422
32-2	Burner Body	7855P-606	38-1	CH Return Pipe Gasket	7855P-074
32-3	Burner Gasket	7855P-419	39	CH Return Sensor	7855P-097
32-4	Ceramic Fiber Burner	7855P-420	39-1	CH Return Sensor Gasket	7855P-364
32-5	Ignitor	7855P-607	40	Condensate Trap Assembly	7855P-605
32-6	Ignitor Gasket	7855P-252	40-1	Condensate Trap O-Ring P22A	7855P-276
32-7	Burner Overheat Switch	7855P-066	41	Sight Glass	7855P-401
33	CH Supply Temperature Sensor	7855P-030			

Table 44 - Heat Exchanger Replacement Parts - 175 - 199 Floor and Wall Mount Models

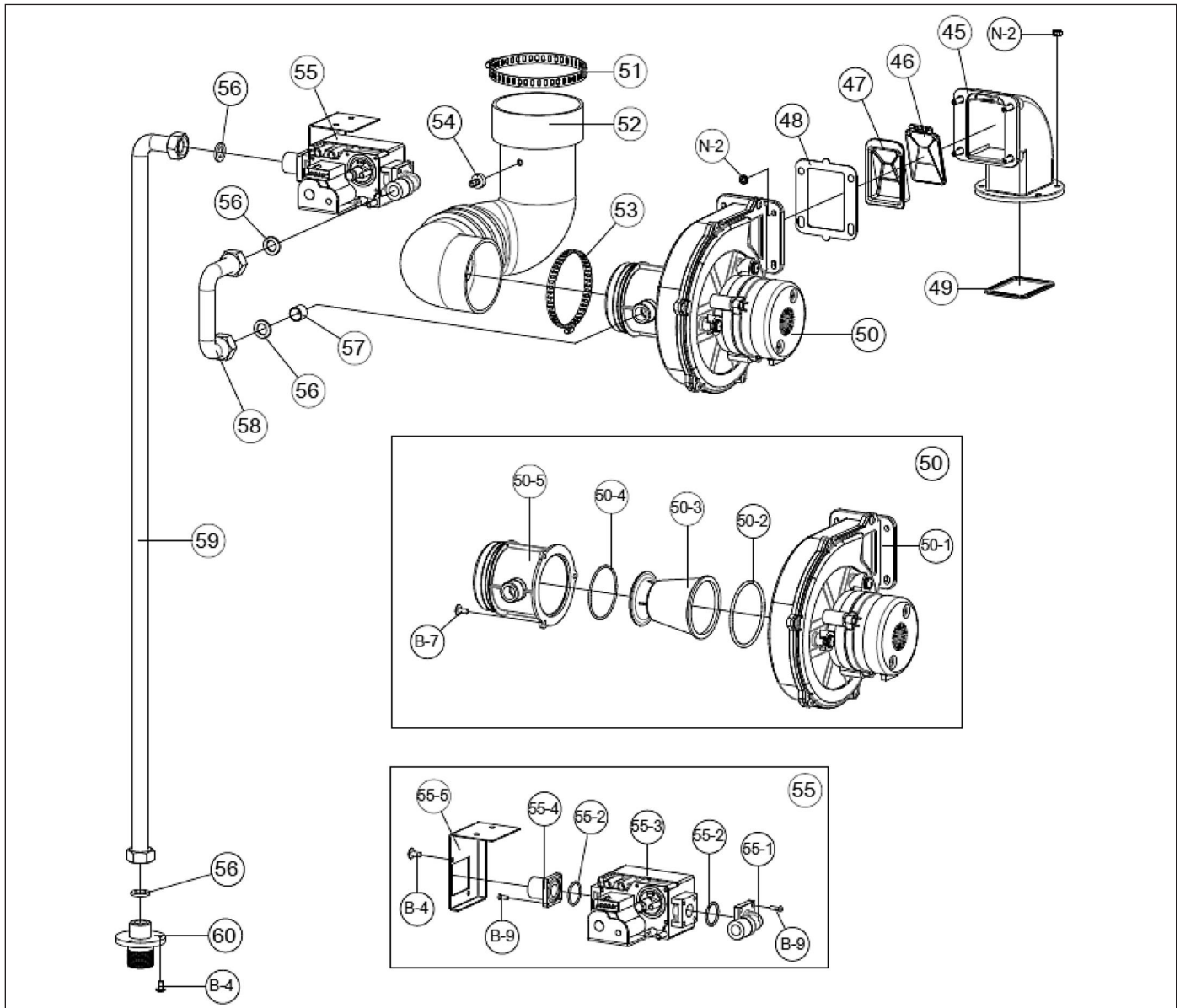
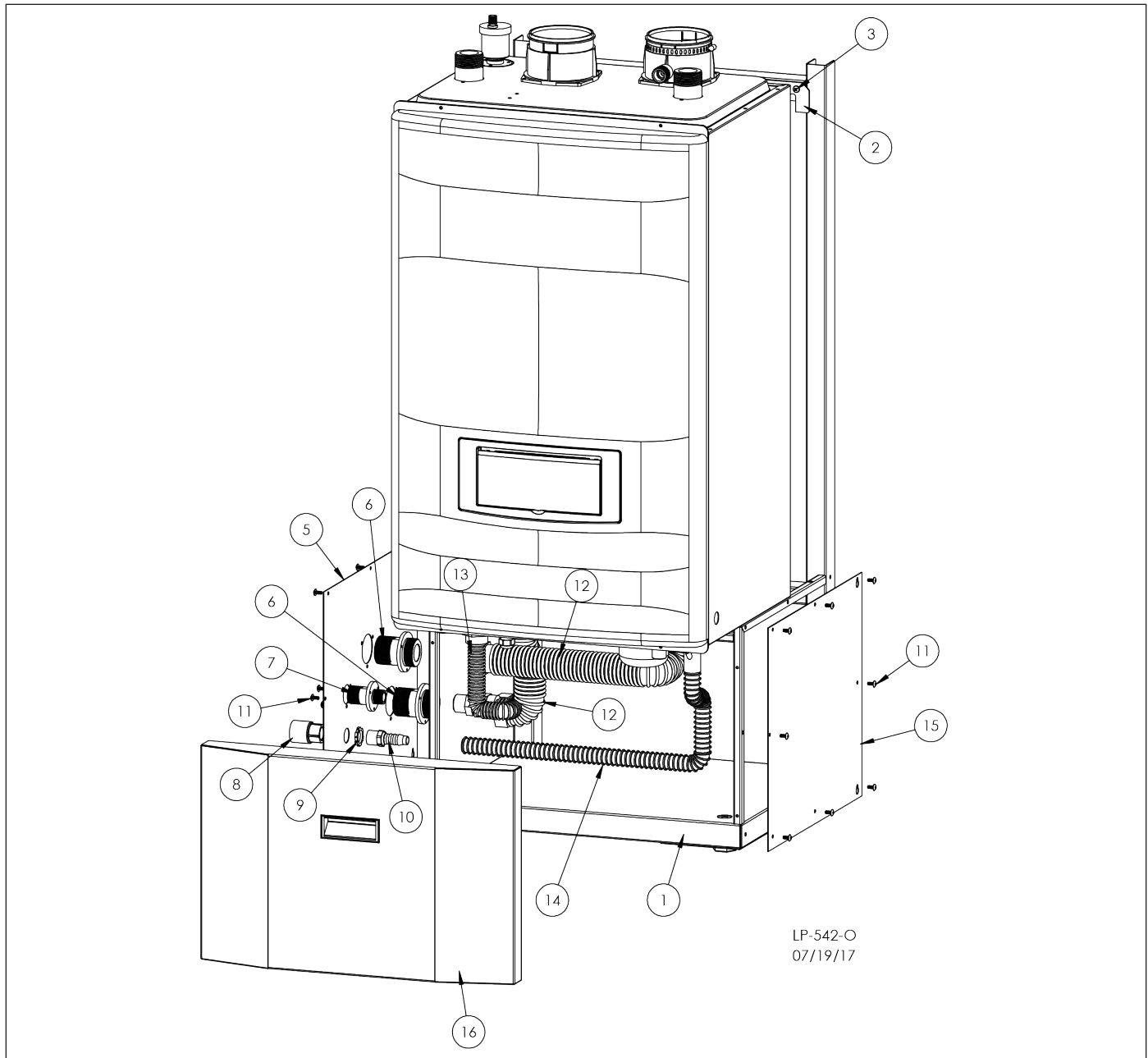

Figure 74 - Combustion System Replacement Parts - 175 - 199 Models

NUMBER	DESCRIPTION	PART NUMBER	NUMBER	DESCRIPTION	PART NUMBER
45	Burner Inlet Channel (with Damper)	7855P-424	51	Air Intake Hose Top Clamp	7855P-429
46	Air Damper	7855P-618	52	Air Intake Hose	7855P-430
			53	Air Intake Hose (Bottom Clamp)	7855P-429
47	Air Damper Guide	7855P-369	54	APS Hose Fitting	7855P-375
48	Fan Outlet Gasket	7855P-425	55	Gas Valve Assembly	7855P-431
49	Burner Inlet Channel Gasket	7855P-426	55-1	Gas Valve Outlet Adapter	7855P-232
50	Fan and Mixer Assembly	7855P-427	55-2	Gas Valve O-Ring	7855P-076
			55-3	Gas Valve	7855P-034
			55-4	Gas Valve Inlet Adapter	7850P-077
			55-5	Gas Valve Bracket	7855P-436
			56	1/2" Gas Pipe Gasket	7855P-221
50-1	Fan	7855P-025	57	Gas Orifice (NG) 8.3 mm	7855P-610
50-2	Fan O-Ring	7855P-371		Gas Orifice (LP) 6.3 mm	7855P-435
50-3	Air Gas Mixer (Inner Part)	7855P-609	58	Gas Pipe (to Mixer)	7855P-432
50-4	Air Gas Mixer Gasket	7855P-428	59	Gas Pipe (to Gas Valve)	7855P-433
50-5	Air Gas Mixer (Outer Part)	7855P-608	60	Gas Inlet Adapter (3/4")	7855P-382

Table 45 - Combustion System Replacement Parts - 175 - 199 Floor and Wall Mount Models



LP-542-O
07/19/17

Figure 75 - Floor Model Replacement Parts

Item #	Description	80 - 140 Model	175 - 199 Model	Item #	Description	80 - 140 Model	175 - 199 Model
1	Base Assembly, Floor Stand	7865P-001	7865P-002	10	Barb Fitting 1/2"	7100P-044	
2	Anchor and Wall Bracket		7850P-084	11	Screw M4 x 10MM	7855P-390	
3	Screw M5 x 12MM		7865P-023	12	1" ID SS Flex - 24" Long	7865P-014	
4	Screw M6 x 12MM (Not Shown)		7865P-024	13	SS Gas Flex - 18" Long	7865P-015	7865P-016
5	Right Side Panel w/ Labels	7865P-005	7865P-006	14	Condensate Hose	7855P-089	
6	Adapter, 1 1/4" x 1 1/4"		7865P-009	15	Left Side Panel, Floor Stand	7865P-007	7865P-008
7	Adapter, 3/4" x 1/2"		7865P-019	16	Front Cover Assy, Floor Stand	7865P-003	7865P-004
8	Adapter PVC, 3/4" x 1/2"		7450P-086	Not Shown	1 1/4" EPDM Gasket	7865P-020	
9	Locknut - Electrical - 1/2"		7700P-002				

Table 46 - Floor Model Replacement Parts

Limited Warranty for UFT Boilers

HTP warrants this boiler and its components to be free from defects in material and workmanship according to the following terms, conditions, and time periods. UNLESS OTHERWISE NOTED THESE WARRANTIES COMMENCE ON THE DATE OF INSTALLATION. This limited warranty is only available to the **original consumer purchaser** (hereinafter "Owner") of this boiler, and is non-transferable.

Residential Use Warranty
Ten (10) years – Heat Exchanger, Five (5) Years – Components
Commercial Use Warranty
Seven (7) years – Heat Exchanger, One (1) Year – Components
Use Definitions - Residential Heating means heating a single family dwelling. This dwelling must be either: a) owned and resided in by the original purchaser; or b) a residential rental property that services a single dwelling in which the original purchaser resides on a permanent basis. Commercial Use refers to all other applications.

COVERAGE

- A. Residential Use - During the first five (5) years after the original date of installation, HTP warrants that it will repair or replace, at its option, any defective or malfunctioning component of the boiler with a component of equivalent size and current model. Replacement components will be warranted for ninety (90) days. Commercial Use - During the first year after the original date of installation, HTP warrants that it will repair or replace, at its option, any defective or malfunctioning component of the boiler with a component of equivalent size and current model. Replacement components will be warranted for ninety (90) days.
- B. Should a defect or malfunction result in a leakage of water from the boiler within the above-stated warranty periods due to defective material or workmanship, malfunction, or failure to comply with the above warranty, with such defect or malfunction having been verified by an authorized HTP representative, HTP will replace the defective or malfunctioning boiler with a replacement of the nearest comparable model available at the time of replacement. The replacement boiler will be warranted for the unexpired portion of the applicable warranty period of the original boiler.
- C. In the event of a leakage of water of a replacement boiler due to defective material or workmanship, malfunction, or failure to comply with the above warranty, HTP reserves the right to refund to the Owner the published wholesale price available at the date of manufacture of the original boiler.
- D. If government regulations, industry certification, or similar standards require the replacement boiler or component(s) to have features not found in the defective boiler or component(s), the Owner will be charged the difference in price represented by those required features. If the Owner pays the price difference for those required features and/or to upgrade the size and/or other features available on a new replacement boiler or component(s), the Owner will also receive a complete new limited warranty for that replacement boiler or component(s).
- E. If at the time of a request for service the Owner cannot provide a copy of the original sales receipt or the warranty registration, the warranty period for the boiler shall then be deemed to have commenced thirty (30) days after the date of manufacture of the boiler and NOT the date of installation of the boiler.
- F. This warranty extends only to boilers utilized in heating applications that have been properly installed by qualified professionals based upon the manufacturer's installation instructions.
- G. It is expressly agreed between HTP and the Owner that repair, replacement, or refund are the exclusive remedies of the Owner.

OWNER RESPONSIBILITIES

The Owner or Qualified Installer / Service Technician must:

1. Have a relief valve bearing the listing marks of the American Society of Mechanical Engineers (ASME) installed with the boiler assembly in accordance with federal, state, and local codes.
2. Maintain the boiler in accordance with the maintenance procedure listed in the manufacturer's provided instructions. Preventive maintenance can help avoid any unnecessary breakdown of the boiler and keep it running at optimum efficiency.
3. Maintain all related system components in good operating condition.
4. Use the boiler in an open system, or in a closed system with a properly sized and installed thermal expansion tank.
5. Use the boiler at water pressures not exceeding the working pressure shown on the rating plate.
6. Keep the boiler free of damaging scale deposits.
7. Make provisions so if the boiler or any component or connection thereto should leak, the resulting flow of water will not cause damage to the area in which it is installed.

WARRANTY EXCLUSIONS

This limited warranty will not cover:

1. Any boiler purchased from an unauthorized dealer.
2. Any boiler not installed by a qualified heating installer/service technician, or installations that do not conform to ANSI, CSA, and/or UL standards, as well as any applicable national or local building codes.
3. Service trips to teach the Owner how to install, use, maintain, or to bring the boiler installation into compliance with local building codes and regulations.
4. The workmanship of any installer. The manufacturer disclaims and does not assume any liability of any nature caused by improper installation, repair, or maintenance.
5. Electricity or fuel costs, or increased or unrealized savings for same, for any reason whatsoever.
6. Any water damage arising, directly or indirectly, from any defect in the boiler or component part(s) or from its use.
7. Any incidental, consequential, special, or contingent damages or expenses arising, directly or indirectly, from any defect in the boiler or the use of the boiler.
8. Failure to locate the boiler in an area where leakage of the boiler or water line connections and the relief valve will not result in damage to the area adjacent to the boiler or lower floors of the structure, as well as failure to install the boiler with properly designed containment measures.
9. Any failed components of the system not manufactured by HTP as part of the boiler.
10. Boilers repaired or altered without the prior written approval of HTP.
11. Damages, malfunctions, or failures resulting from improper installation, or failure to install the boiler in accordance with applicable building codes/ordinances or good plumbing and electrical trade practices; or failure to operate and maintain the boiler in accordance with the manufacturer's provided instructions.
12. Damages, malfunctions, or failures resulting from failure to operate the boiler at pressures not exceeding the working pressure shown on the rating label.
13. Failure to operate the appliance in an open system, or in a closed system with a properly sized and installed thermal expansion tank.
14. Failure or performance problems caused by improper sizing of the boiler, expansion device, piping, or the gas supply line, the venting connection, combustion air openings, electric service voltage, wiring or fusing.
15. Damages, malfunctions, or failures caused by improper conversion from natural gas to LP gas or LP gas to natural gas.
16. Damages, malfunctions, or failures caused by operating the boiler with modified, altered, or unapproved components, or any component / attachment not supplied by HTP.
17. Damages, malfunctions, or failures caused by abuse, accident, fire, flood, freeze, lightning, electrochemical reaction, acts of God and the like.
18. Failures (leaks) caused by operating the boiler in a corrosive or

contaminated atmosphere.

19. Damages, malfunctions, or failures caused by operating an empty or partially empty boiler (“dry firing”), or failures caused by operating the boiler when it is not supplied with water, free to circulate at all times.

20. Any damage or failure of the boiler due to the accumulation of solid materials or lime deposits.

21. Any damage or failure resulting from improper water chemistry. See following page for water chemistry requirements.

Contaminant	Level
Total Hardness (140°F and above water temperature)	120 mg/l (7 grains/gallon)
Aluminum	0.05 to 0.2 mg/l
Chloride	100 mg/l
Color	15 color units
Copper	1.0 mg/l
Corrosivity	Non-corrosive
Fluoride	2.0 mg/l
Foaming Agents	0.5 mg/l
Iron	0.3 mg/l
Manganese	0.05 mg/l
Odor	3 threshold odor number
pH	6.5 – 8.5
Silver	0.1 mg/l
Sulfate	250 mg/l
Total Dissolved Solids (TDS)	500 mg/l
Zinc	5 mg/l
Dissolved Carbon Dioxide (CO2)	15 mg/l or ppm

22. Any damages, malfunctions, or failures resulting from the use of dielectric unions.

23. Boilers replaced for cosmetic reasons.

24. Components of the boiler that are not defective, but must be replaced during the warranty period as a result of reasonable wear and tear.

25. Components of the boiler that are subject to warranties, if any, given by their manufacturers; HTP does not adopt these warranties.

26. Damages, malfunctions, or failures resulting from the use of any attachment(s) not supplied by HTP.

27. Boilers installed outside the fifty states (and the District of Columbia) of the United States of America and Canada.

28. Boilers moved from the original installation location.

29. Boilers that have had their rating labels removed.

PROCEDURES FOR WARRANTY SERVICE REQUESTS

Any claim for warranty assistance must be made immediately upon finding the issue. First, please consult the HTP Warranty Wizard (<http://www.htproducts.com/Warranty-Wizard.html>) to check warranty eligibility. You may also contact HTP Technical Support at 1-800-323-9651 for questions or assistance. Warranty coverage requires review and approval of the issue with HTP Technical Support or through the Warranty Wizard prior to a full unit replacement. Any claim for warranty reimbursement will be rejected if prior approval from HTP is not obtained in advance of a full unit replacement. Final determination will be made as part of the warranty claim process.

When submitting a warranty claim the following items are required:

- 1. Proof of purchase or installation of the product** – Typically a copy of the invoice from the installing contractor, the receipt of the purchase of the product, or an original certificate of occupancy for a new home.
- 2. Clear pictures (or video) of the following:**
 - a. Serial number tag (sticker)
 - b. The product
 - c. The product issue / failure whenever possible
 - d. A picture of the piping near the product

e. For gas fired products, a picture of the venting, including how it exits the building

All claims will be reviewed by HTP within three (3) business days. If additional information is required and requested by the HTP Claims Department you will have thirty (30) days to provide it. When all requested information is provided HTP will respond within three (3) business days. The claim will be automatically closed if requested information is not provided within thirty (30) days. Claims will not be reopened without HTP Warranty Supervisor approval.

During the claims process a product that must be replaced will be given a designation of either a) field scrap, or b) return to HTP. If the product must be returned to HTP, the returned product must arrive at HTP within thirty (30) days of the date of our request to return the product. After receipt of the returned product HTP may require as many as thirty (30) additional days for product testing. **NOTE: Any components or heaters returned to HTP for warranty analysis will become the property of HTP and will not be returned, even if credit is denied.**

If you have questions about the coverage of this warranty, please contact HTP at the following address or phone number: HTP, 272 Duchaine Blvd., New Bedford, MA, 02745, Attention: Warranty Service Department, 1(800) 323-9651.

SERVICE, LABOR AND SHIPPING COSTS

Except when specifically prohibited by the applicable state law, the Owner, and not the Manufacturer, shall be liable for and shall pay for all charges for labor or other expenses incurred in the removal, repair, or replacement of the boiler or any component part(s) claimed to be defective or any expense incurred to remedy any defect in the product. Such charges include, but are not necessarily limited to:

1. All freight, shipping, handling, and delivery costs of forwarding a new boiler or replacement part(s) to the owner.
2. All costs necessary or incidental in removing the defective boiler or component part(s) and installing a new boiler or replacement part(s).
3. All administrative fees incurred by the Owner, as well as material required to complete, and/or permits required for, installation of a new boiler or replacement part(s), and
4. All costs necessary or incidental in returning the defective boiler or component part(s) to a location designated by the manufacturer.

LIMITATIONS OF YOUR HTP WARRANTY AND REMEDIES

THE FOREGOING WARRANTIES ARE EXCLUSIVE AND ARE GIVEN AND ACCEPTED TO THE FURTHEST EXTENT UNDER APPLICABLE LAW IN LIEU OF ANY AND ALL OTHER WARRANTIES, EXPRESS OR IMPLIED, INCLUDING WITHOUT LIMITATION THE IMPLIED WARRANTIES OF MERCHANTABILITY AND FITNESS FOR A PARTICULAR PURPOSE AND ANY OBLIGATION, LIABILITY, RIGHT, CLAIM OR REMEDY IN CONTRACT OR TORT, WHETHER OR NOT ARISING FROM HTP’S NEGLIGENCE, ACTUAL OR IMPUTED. THE REMEDIES OF THE OWNER SHALL BE LIMITED TO THOSE PROVIDED HEREIN TO THE EXCLUSION OF ANY OTHER REMEDIES INCLUDING WITHOUT LIMITATION, INCIDENTAL OR CONSEQUENTIAL DAMAGES, SAID INCIDENTAL AND CONSEQUENTIAL DAMAGES INCLUDING, BUT NOT LIMITED TO, PROPERTY DAMAGE, LOST PROFIT OR DAMAGES ALLEGED TO HAVE BEEN CAUSED BY ANY FAILURE OF HTP TO MEET ANY OBLIGATION UNDER THIS AGREEMENT INCLUDING THE OBLIGATION TO REPAIR AND REPLACE SET FORTH ABOVE. NO AGREEMENT VARYING OR EXTENDING THE FOREGOING WARRANTIES, REMEDIES OR THIS LIMITATION WILL BE BINDING UPON HTP. UNLESS IN WRITING AND SIGNED BY A DULY AUTHORIZED OFFICER OF HTP. THE WARRANTIES STATED HEREIN ARE NOT TRANSFERABLE AND SHALL BE FOR THE BENEFIT OF THE ORIGINAL OWNER ONLY.

NO OTHER WARRANTIES

This warranty gives the Owner specific legal rights. The Owner may also have other rights that vary from state to state. Some states do not allow the exclusion or limitation of incidental or consequential damages so this limitation or exclusion may not apply to the Owner.

These are the only written warranties applicable to this boiler manufactured and sold by HTP. HTP neither assumes nor authorizes anyone to assume for it any other obligation or liability in connection with said boilers. HTP reserves the right to change specifications or discontinue models without notice.

**This Page Intentionally
Left Blank**

**This Page Intentionally
Left Blank**

Customer Installation Record Form

The following form should be completed by the Qualified Installer / Service Technician for you to keep as a record of the installation in case of a warranty claim. After reading the important notes at the bottom of the page, please also sign this document.

Customer's Name	
Date of Installation	
Installation Address	
Product Name / Serial Number(s)	
Comments	
Installer's Code / Name	
Installers Phone Number	
Signed by Installer	
Signed by Customer	
Installation Notes	

IMPORTANT

Customer: Please only sign after the Qualified Installer / Service Technician has fully reviewed the installation, safety, proper operation, and maintenance of the system. If the system has any problems please call the Qualified Installer / Service Technician. If you are unable to make contact, please call your sales representative.

Distributor / Dealer: Please insert contact details.