



*Owner's
Manual.
Multi-Oil
Furnaces*

MODELS

***155, 200, 245, 315 ; 235, 350, & 500
(Single pass ; 3-Pass Units)***

All Installations Must Be In Accordance With State and Local Codes and it is the responsibility of the installer to assure all codes are met

For service, call your dealer or installer at

Date Installed:

WARRANTY NOTICE

Use of equipment on any equipment not manufactured or designed for use VOIDS the warranty - property or personal damage could occur.

Table of Contents

SPECIFICATIONS	3
PACKING LIST	5
COMPONENT IDENTIFICATION.....	5
FIELD ASSEMBLY INSTRUCTIONS - BLOWER.....	12
FIELD ASSEMBLY INSTRUCTIONS - BURNER.....	13
HEATER INSTALLATION PROCEDURE.....	14
INSTALLATION ILLUSTRATION –VERTICAL CHIMNEY	15
ALTERNATE STACK INSTALLATION WITH INDUCER.....	16
COMPRESSED AIR SUPPLY.....	17
OIL PUMP MOUNTING.....	17
FINISHING THE PLUMBING.....	17
ELECTRICAL CONNECTIONS.....	20
INITIAL START UP AND OPERATING SEQUENCE	33
FAN LIMIT SWITCH SETTINGS.....	35
FINE TUNING THE BURNER	36
PRIMARY CONTROL FUNCTION - SAFETY LOCKOUT	37
ROUTINE HEATER AND BURNER MAINTENANCE.....	38
WEEKLY MAINTENANCE	38
BURNER.....	38
ASSEMBLY OF NOZZLE	39
ASSEMBLY OF OIL AND AIR SOLENOID #57190.....	40
ASSEMBLY OF OIL REGULATOR #57129	41
END OF HEATING SEASON/SUMMER STORAGE.....	43
TROUBLE – SHOOTING GENERAL	44
PARTS REPLACEMENT IDENTIFICATION	65
HEATER PARTS LIST.....	47
FIRELAKE’S WARRANTY.....	71

SPECIFICATIONS

Model 'A' Oil Pump

1/4 " FNPT
 1/8 FNPT
 40-60 PSI
 6 GPH
 3450 RPM
 1/4
 CW Shaft End
 20" Hg
 10' Vertical
 <30', use 3/4" pipe
 30-90', use 1" pipe

Inlet Port
 Outlet Port
 Pressure Range
 Max. Flow
 Max Allowable Speed
 HP
 Rotation
 Max Operating Vacuum
 Maximum Suggested Lift
 Horizontal Suction Piping
 Horizontal Suction Piping

Model 'J' Oil Pump

1/4 " FNPT
 1/8 " FNPT
 20-40 PSI
 18 GPH
 3450 RPM
 1/4
 CW Shaft End
 20" Hg
 10' Vertical
 <30', use 3/4" pipe
 30-90', use 1" pipe

<i>Maximum Fuel Consumption</i>			<u>Model</u>	<u>U.S. Gal./Hr.</u>	<u>liters/hr</u>	<u>Model</u>	<u>U.S. Gal./Hr.</u>	<u>liters/hr</u>
			155	1.1	4.2	200	1.43	5.41
<u>Model</u>	<u>U.S. Gal./Hr.</u>	<u>liters/hr</u>	245	1.75	6.62	315	2.25	8.52
235	1.6	6	350	2.5	9.46	500	3.6	13.6

Air Pump (Burner mounted, fits all but Mdl 350, 500) 3450 rpm, filtered inlet, 20 psi discharge.

Minimum Heater Clearances

Above: 6"(15cm) Inlet Blower: 18"(46cm) Rear: 18"(46cm) Chimney Connector: 18"(46cm)
 Below: 18"(46cm) Outlet Louver: 84"(2.1m) Front: 24"(61cm)

Cabinet Dimensions (includes stack collars but not blower or burner)

<u>Model</u>	<u>Length</u>	<u>Width</u>	<u>Height</u>	<u>Weight</u>	<u>Hot Air Outlet</u>
155	66"(1.67m)	22"(56cm)	18"(46cm)	150#(68kg)	15" sq. (38cm)
200	79"(2m)	22"(56cm)	22"(56cm)	167#(76kg)	15" sq. (38cm)
245	82"(2.1m)	26"(66cm)	22"(56cm)	200#(91kg)	18" sq. (46cm)
315	96"(2.5m)	26"(66cm)	22"(56cm)	256#(116kg)	18" sq. (46cm)
235	42"(1.1m)	32"(0.8m)	33"(84cm)	350#(160kg)	23x29"(58x74cm)
350	55"(1.4m)	52"(1.32m)	33"(84cm)	800#(364kg)	23x29"(58x74cm)
500	55"(1.4m)	52"(1.32m)	33"(84cm)	800#(364kg)	23x41"(58x104cm)

Overall Dimensions of Heater with Burner and Blower

<u>Model</u>	<u>Length</u>	<u>Width</u>	<u>Height</u>	<u>Weight</u>
155	79.5"(2.0m)	22"(56m)	34.5"(88cm)	234#(106kg)
200	92.5"(2.3m)	22"(56m)	34.5"(88cm)	251#(114kg)
245	95.5"(2.3m)	26"(66m)	41"(1m)	348#(158kg)
315	109.5"(2.8m)	26"(66m)	41"(1m)	348#(158kg)
235	52"(1.3m)	42"(1.1m)	33"(0.84m)	480#(217kg)
350	59"(1.5m)	62"(1.57m)	33"(0.84m)	927#(421kg)
500	59"(1.5m)	62"(1.57m)	33"(0.84m)	927#(421kg)

Construction and Specifications: **Certified by UL and filed in MH16601 (US & Canada)**

Heat Exchanger : Stainless and/or aluminized steel. Exhaust collars 8" (20cm), 10" (25.4cm) model 500. Stack allows connection to either side (except 350,500). Cap provided must be installed on unused collar.

Cabinet : Mill coated appliance grade painted steel. The louvered opening may be rotated and/or placed on either side and filler panel is provided and installed on the side opposite the outlet (Except model 350, 500). Burner is attached to a hinged door that allows for easy clean out as well as inspection of nozzle area.

Blower HP (Min.) : Model 15, 20, 35: 3/4 HP. Model 24, 31, 50: 1HP

INTRODUCTION

Purchase of a multi-oil furnace is a wise investment. To maximize the return on this investment you must read and save this manual. It contains installation instructions, diagnostic procedures, burner cleaning, maintenance procedures and parts ordering information. Follow the installation instructions carefully. You can expect years of reliable performance with a properly installed and maintained system.

This furnace is: not for residential use; burns only oil generated on premise unless regulating authorities give written permission; required to have monthly ash removal from heat exchanger and flue; required to have monthly oil feed systems cleaned; required to have cleaning done by persons using proper protective clothing like masks and gloves; required to have only qualified service people adjust controls; requires a oil feed valve near the tank to be closed when burner is not being used over extended periods; to be installed by a qualified installer, one who is engaged in, responsible for or thoroughly familiar with the permitting, installation and operation of oil-fired appliances, who is experienced in such work and is familiar with the precautions required, and who will comply with all the requirements of the Authority having jurisdiction over the installation. Refer to details in this manual for other information.

The installation of equipment in the United States must consider the requirements of the following publications of the National Fire Protection Association, Battery March Park, Quincy, Massachusetts 02269:

N.F.P.A.	No. 30	Flammable and Combustible Liquid Codes
N.F.P.A.	No. 31	Standard for Installation of Oil Burning Equipment
N.F.P.A.	No. 88A	Standard for Parking Structures
N.F.P.A.	No. 88B	Standard for Repair Garages
N.F.P.A.	No. 211	Standard for Chimney, Fireplaces, Vents and Solid Fuel Burning Appliances

The installation of Equipment in Canada must consider the requirements of C.S.A., Standard B 139, B140, Installation Code for Oil Burning Equipment.

This heater is recommend for burning #2 fuel oil, used; motor oil, automatic transmission fluid, hydraulic oil and gear oil mixed not to exceed 50 SAE. Such oils may contain gasoline and specific precautions on the handling and storage of waste oils are to be observed.

Do Not add to oil supply or burn: unknown garbage oils, gasoline, naptha, chlorinated cleaning solvents or oil additives in this furnace.

Unpacking Heater Components

The heater should be completely removed from its shipping crate. Remove all bolts attaching the wood runners to the heater. Brackets can be left on heater for mounting heater to tank, wall, or suspended frame. Remove cleaning tool and parts from inside the chamber prior to installing heater. Be prepared to experience operating problems such as plugged nozzles, suction line leaks, etc. during the first few weeks of use. Follow start up instructions for purging fuel and air lines to help avoid these problems.

PACKING LIST

Components of a Model 155, 200, 245, 315 Heater:

Crated Heat Exchanger with Cabinet (remove clean out tool and parts from inside the chamber)

Burner (factory test fired burner in shaped foam packaging, save box should shipping be needed)

Blower Assembly (Save box.)

Accessory Carton (Cleanable Oil Filter, 1/2" Cutoff valve, 3/4" Suction Screen, 3/4" Check Valve, Wall Thermostat, 1/2" x 1/4" Swivel, 3/4" x 1/2" Swivel, 1/4" x 1/4" x 1/8" Tee, 1/4" x 1/2" Hex Nipple, 1/2" x 2 Hex Nipple, 1/4" x 2" Nipple, Warranty Card & Manual , (2) Pressure Gauge)

Barometric Damper (for chimney)

Oil Transfer Pump

COMPONENT IDENTIFICATION



Crated or Boxed Exchanger



Burner (appearance varies by model)

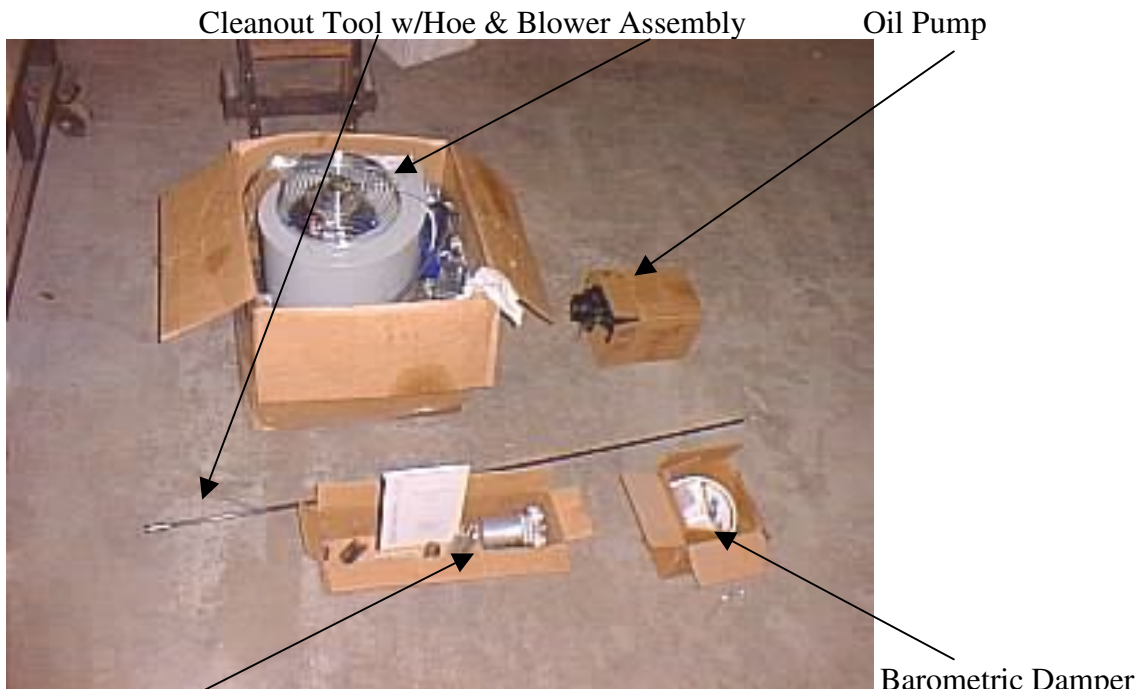

Accessory Carton

Components of a Model 235, 350, 500 Heater:

Heat Exchanger with Cabinet (remove fan, accessories, & target from inside the chamber)

Burner (factory test fired burner in shaped foam packaging, save box should shipping be needed)

Accessory Carton (Cleanable Oil Filter, Fan Motor, 1/2" Cutoff valve, 3/4" Suction Screen, 3/4" Check Valve, Wall Thermostat, 1/2" x 1/4" Swivel, 3/4" x 1/2" Swivel, 1/4" x 1/4" x 1/8" Tee, 1/4" x 1/2" Hex Nipple, 1/2" x 2 Hex Nipple, 1/4" x 2" Nipple, Warranty Card & Manual , (2) Pressure Gauge)

Barometric Damper (for chimney)

Oil Transfer Pump

Fan



Heat Exchanger w/ Cabinet

Remove this cabinet panel to slide out fan, accessories carton, damper, and access target.



BURNER (appearance varies by model)

MODEL 155, 200, 245, 315
HEATER COMPONENTS IDENTIFICATION

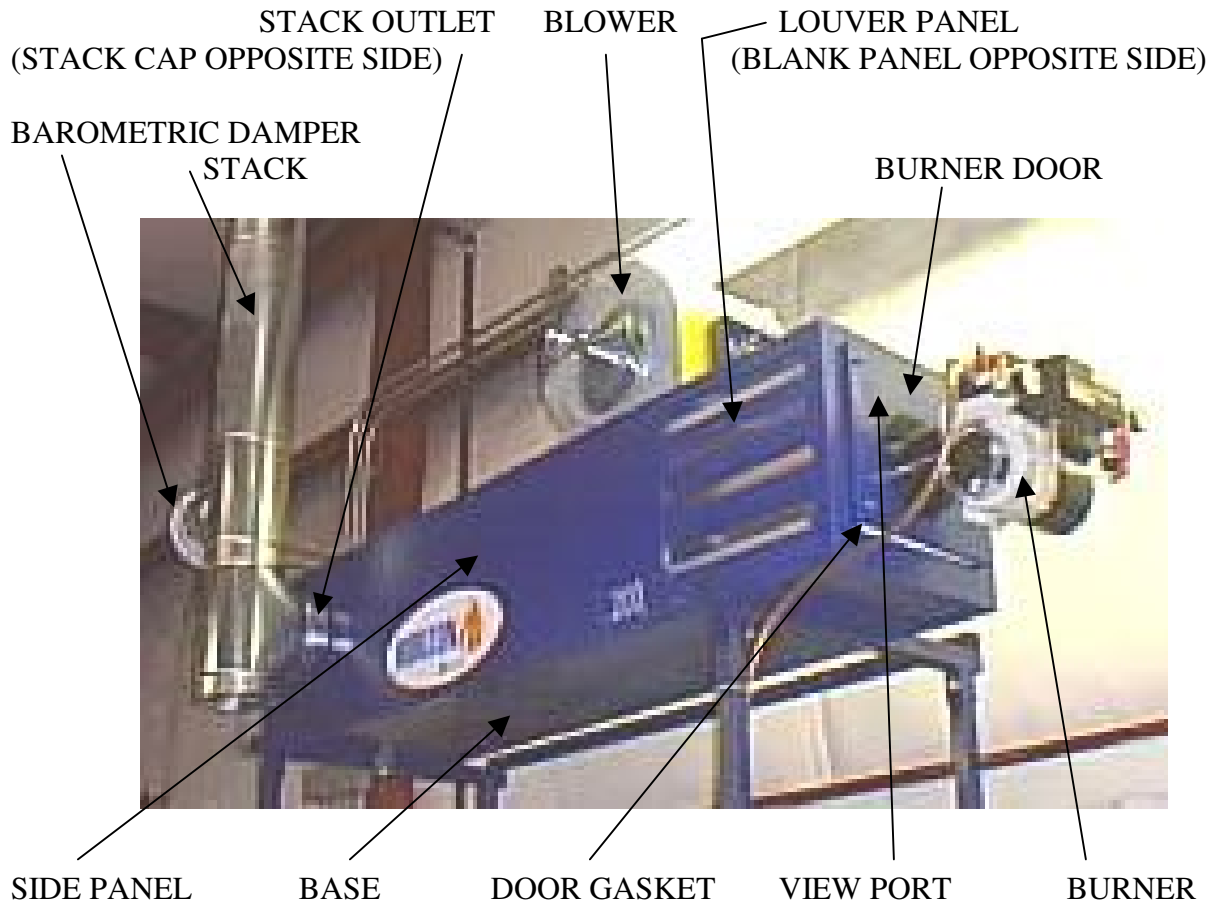

(2) Bolt on brackets each end for attaching to framework or rods. Can be put on lower edge too.
BLOWER/GUARD FAN SWITCH 6 X 6 ELECTRICAL BOX

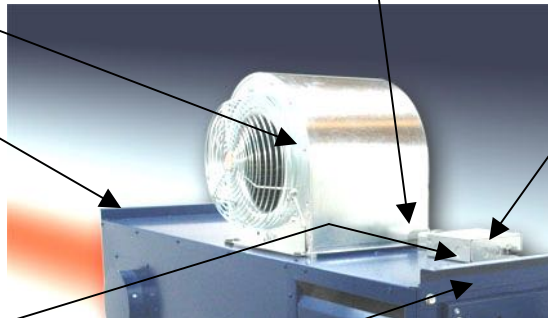

CORD LOCKING CLAMP BEHIND BRACKET PREVENTS BURNER DOOR FROM OPENING WHILE POWERED. TAKE SLACK FROM CORD WHEN INSTALLING.

MODEL 235, 350, 500 HEATER COMPONENTS IDENTIFICATION

LOUVERS (HOT AIR OUTLET) (LOUVERS ARE NOT USED WITH DUCTED MODELS)
FAN CONTROL (OFTEN CALLED FAN LIMIT SWITCH)
ELECTRICAL AND FAN RELAY JUNCTION BOXES



VIEW PORT HINGED BURNER MOUNT CLEANING ACCESS PANEL

FAN OPENING

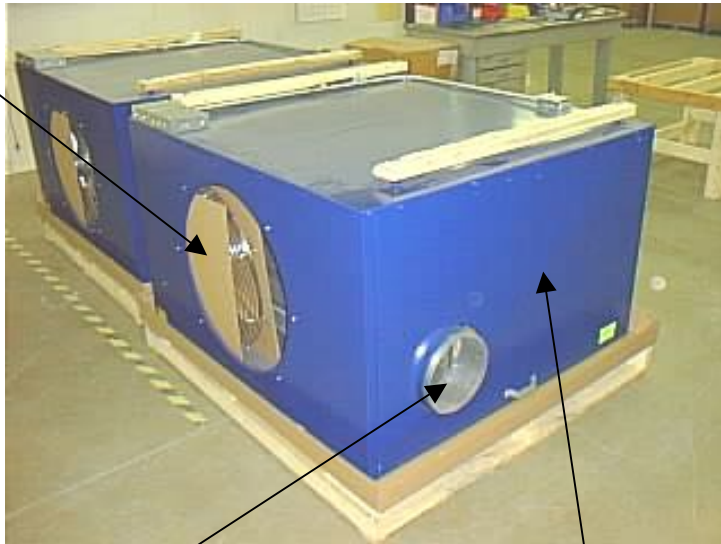

STACK COLLAR EXCHANGER CLEANING ACCESS PANEL

MODEL 235, 350, 500 AIR MOVER ASSEMBLY INSTRUCTIONS PROPELLER FAN ASSEMBLY



Remove fan motor from carton, attach it to the wire fan guard using motor studs and nuts/washers. Place fan blade on shaft, hub away from motor. Allow 1.5" clearance from wire guard to blades. Fan will flex toward motor when running. Secure blade to shaft **snugly** using set screws. Mark shaft to show hub's position. Align motor's conduit to reach electrical box. Align guard/fan assembly to pilot holes on rear cabinet panel, attach with screws. Fan blades must not contact heater parts when turning. After one day check the shaft mark regarding hub's position. If it has moved, reset and tighten set screws.

MODEL K5 (w/Air Pump) BURNER COMPONENTS IDENTIFICATION

(Actual parts may look different as Firelake often updates components to latest technologies)

AIR FILTER AIR PRESSURE SWITCH OIL PRESSURE GAUGE®ULATOR
OIL FEED PIPE IGNITER SAFETY

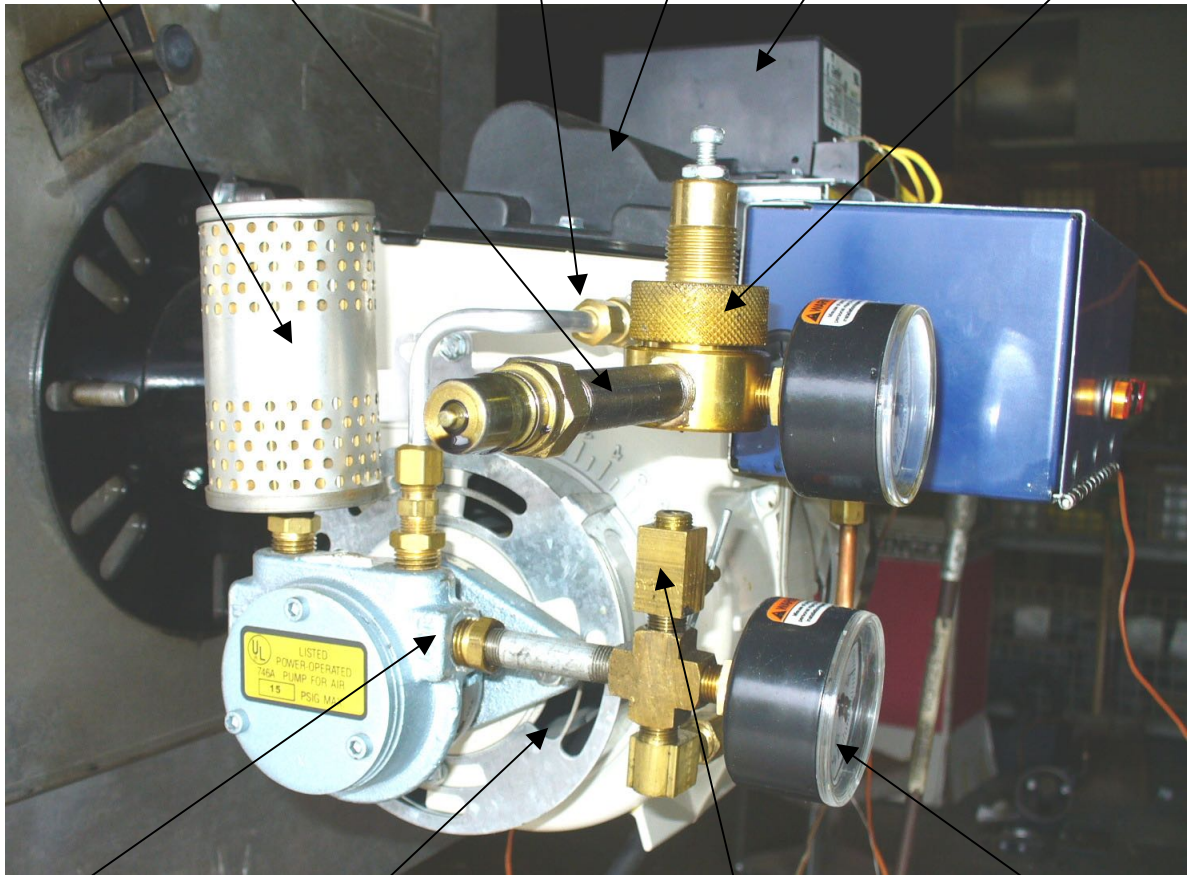

AIR PUMP OUTLET AIR PRESSURE ADJUSTING VALVE AIR GAUGE
COMBUSTION AIR INLET PORTS

NOT SHOWN IN ABOVE VIEW, THIS BURNER ALSO HAS A PRIMING TOGGLE SWITCH, SAFETY RESET BUTTON, FLAME RETENTION HEAD, AIR CONTROL BOX, & INDICATOR LIGHTS LIKE MODEL B5 BURNER (no Air Pump) PICTURE SHOWS.

MODEL B5 BURNER COMPONENTS IDENTIFICATION

(Actual parts may look different as Firelake often updates components to latest technologies)

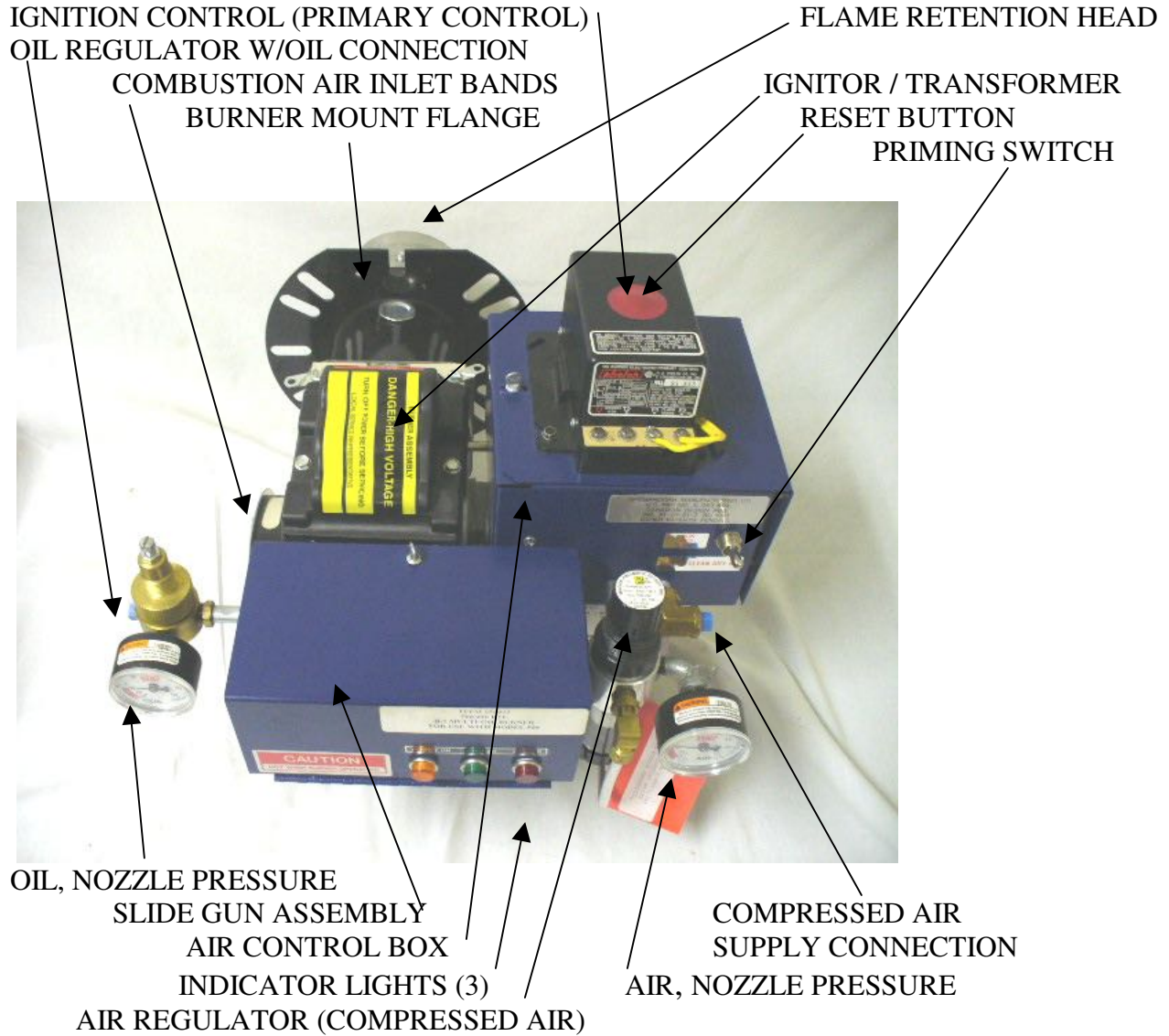

FIELD ASSEMBLY INSTRUCTIONS – MODEL 155/200/245/315 BLOWER



1. Position the Air Deflector, already in the cabinet, so that the upper lip sticks out of the cabinet near the burner end. The lower ends of the Air Deflector are curved to direct the path of the air from the blower to the chimney end. It also creates a barrier to prevent the blower air from bypassing the body of the heat exchanger and going directly to the louvered outlet. NOTE: Small gaps are acceptable between the air deflector, cabinet, and fire chamber.
2. Place the blower in the square opening on the top of the heater so that the top of the air deflector is pinched between the blower housing and edge of the cabinet opening. The blower is placed so that the flat blower housing side is facing the burner. The blower is then secured to the top of the heater with (4) cap screws through the weld nuts in the cabinet.
3. The fan limit switch attached to the 6 x 6 inch electrical box is factory located in a knockout hole beside the blower. Tighten all electrical conduit connections and confirm wires are secured in terminals.
4. The louvered panel and filler panel are interchangeable to control heated air discharge.
5. The stack cap fits both stack outlets and is to be secured to the opposite side of where the chimney will connect. Use two screws to hold the cap or it may work loose over time.

FIELD ASSEMBLY INSTRUCTIONS - BURNER

Upper fins are open to allow light to cad cell

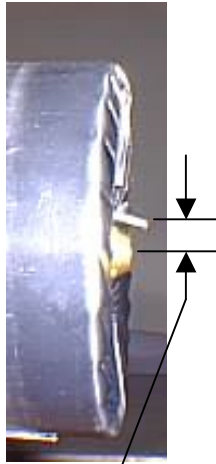

7/16" center of nozzle to electrode



1/8" to 3/16" closest gap

- 1) PRIOR TO INSTALLING BURNER, CHECK FOR SHIPPING DAMAGE TO FLAME RETENTION HEAD AND IGNITION ELECTRODE ALIGNMENT.**
- 2) If components are not as shown you can make adjustments to the electrodes by removing the hole plug on top of burner tube near mount flange. With screw driver, loosen the screw holding the electrode clamping plate. Adjust electrodes as shown. Re-tighten clamp screw. Do not over tighten or insulation on electrodes may crack. Examine electrode position after tightening to be sure position has not changed. Replace hole plug.
- 3) The electrodes should not touch surrounding metal parts or be too close together as they will restrict or divert the arc and not light the oil spray.
- 4) Position the large white insulation gasket(s) found in the blower carton between the furnace door and the face of the heat exchanger. Some models may have them factory installed. Pinch gasket with door and secure door with two nuts. Gaskets not used on model 350, 500.
- 5) Attach burner to furnace door/swing plate. Grasp burner by the mount flange and motor, slip burner's flange over studs on hinged burner door and secure with nuts.

HEATER INSTALLATION PROCEDURE

- 1) Select a location for your heater observing minimum clearance to combustibles. Consider that maintenance and cleaning will be required. Allow adequate work space around burner and stack. Mount heater as low as code allows, easing service and keeping your heat at floor level. Select a noncombustible area or observe minimum clearances to combustibles.
- 2) For best operation minimize distance of horizontal chimney runs. Do not exceed 8' in length. Horizontal runs must have a minimum 1/4" rise per foot. Clean horizontal runs every 500 hours of use or as needed. Ash will accumulate here and block draft. Poor draft causes poor flame, backpressure, oily buildup, unreliable ignition. Use a draft inducer if draft is marginal or inconsistent. Negative pressure is a must in the flame area.
- 3) If suspending the heater use (4) 3/8, 1/2, or 5/8 diameter all-thread and tie into the provided brackets at each end of the cabinet. The mount brackets are designed to attach at the top or bottom of the heater ends to meet various field mounting needs. Lock nuts and washers should be used for safety. Never let the weight of the heater rest on the weaker center portion of cabinet bottom, cabinet will flex. The larger models are more prone to this.
- 4) WASTE OIL FURNACES ARE DEPENDENT ON PROPER DRAFT FOR EFFICIENT BURNING. ASSURE THAT ADEQUATE MAKE-UP AIR IS AVAILABLE. NEGATIVE DRAFT REQUIREMENT: -.04 TO -.06 INCHES OF WATER COLUMN AT FURNACE OUTLET. BUILDING EXHAUST FANS OR COLD BUILDINGS AT NIGHT CAN REVERSE YOUR DRAFT AND CAUSE FUMES, POOR COMBUSTION, OR NUISANCE BURNER LOCKOUTS. TAKE MEASURES TO ASSURE FURNACE WILL HAVE PROPER DRAFT DIRECTION WHEN OPERATING.
- 5) If permanent masonry chimney is not available, use appropriate diameter multi-wall manufactured chimney and collars listed for use with oil fired furnaces per UL 103 or All Fuel Class A. Locate for easy connection to the furnace and install per manufacturers' instructions and local building and fire codes. Normal operation will produce a gross chimney temperature between 500F and 750F.
- 6) The chimney must extend a minimum 3' above the highest roof line within 10'. In general you will need a minimum of 2 feet of vertical for each foot of horizontal for best draft.
- 7) Use a stack that is equal diameter to the furnace outlet. Use minimum 24 gauge single wall connector pipe between furnace outlet and damper. Do not allow rain to come down the chimney and have a path into fire chamber. This will create a rusting environment. Install a chimney tee near the furnace to act as a cleanout / water trap.
- 8) Locate barometric damper near the furnace and face away from blower. Its opening must be visible from the floor and out of strong air flows that could falsely affect its ability to regulate. Read instruction sheet included with damper.

INSTALLATION ILLUSTRATION, ALL MODELS –VERTICAL CHIMNEY



CAUTION with ALL HEATERS & CHIMNEYS

Allow for adequate make-up air to enter the room where the burner operates. Allowing for a opening of 140 square inches per gallon of fuel consumed is normal. Starving the burner of air is more likely in smaller, and well insulated weather tight rooms.



In poor natural draft conditions a draft inducer placed near the outlet can be used to improve poor draft conditions and should be placed as near the roof as possible. Inducers will pull air better than push it. A 1/4 HP like Grainger 4C732 or is suggested. Smaller HP inducers and squirrel cage types will not be strong enough in some chimney installations.

ALTERNATE HORIZONTAL STACK INSTALLATION ALL MODELS USING INDUCER



- **Confirm local building codes will allow inducers & side wall vent**
- **Locate inducer as close to where chimney exits building as practical**
- **Never allow rain or condensation to flow back into heater**
- **Taper end of stack to keep rain out**
- **Place a screen (1/2" or 3/4" openings) over stack to keep animals out**
- **Extend stack away from building 18" or beyond gutters and eaves**
- **Observe clearance to combustible materials**

COMPRESSED AIR (applies to Model B5 burner only, the K5 burner has integral air pump)

1. A minimum 2 CFM at 40 psi is needed into the burner. Use a hydraulic quick disconnect or put ample flex in the line to swing burner open when servicing. A dedicated air compressor at the heater in lieu of using the shop's air system is acceptable. A compressor of 3/4 to 1.5 HP is typical, with a storage tank is a plus. Consult your installer for models available. Drain all compressors frequently to help keep moisture from entering burner.
2. Many burner service problems are from "rusty" air causing burner components to fail. It is wise to use a oiler and/or regulator to treat & reduce air pressure entering the burner to approximately 60 psi. Wear on burner parts will be reduced and ignition more reliable. Providing a drip leg with valve near the burner to trap water, scale, and rust is also a good idea. If water is present take all measures to remove it. The air solenoid may stick and other components may rust and fail.
3. SERVICE TIP: 80% of service problems can be avoided by keeping contaminants like rust chips, water, pipe dope, insects from reaching burner through the air and oil lines.

OIL PUMP MOUNTING

1. Consult your dealer for best plumbing methods before starting. Mount the pump as near the oil supply tank as possible. Minimize suction distance or lift for best operation. You may mount the pump above the tank to suction lift oil to the pump or another option is to place the pump below the tank level to gravity feed or siphon oil to the pump. Do not exceed 10 psi into the pump inlet in any arrangement or the seal may leak. Allow space for service. Be sure to meet all building and fire code requirements.
2. Any pump/motor orientation is acceptable as long as the pump shaft is horizontal. You may rotate the pump head on the mount to simplify plumbing connections. Be sure the motor and pump shafts are aligned and coupling set screws are tight before operating.



Above Tank Mount



Below Tank Level Mount

FINISHING THE PLUMBING.....

J Pump

.1/8" Outlet Air Bleeder .1/4" Inlets

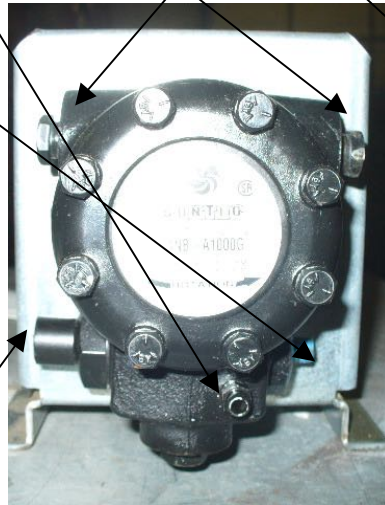

Pressure Adj.

A Pump

Air Bleeder .1/8" Outlet .1/4" Inlet

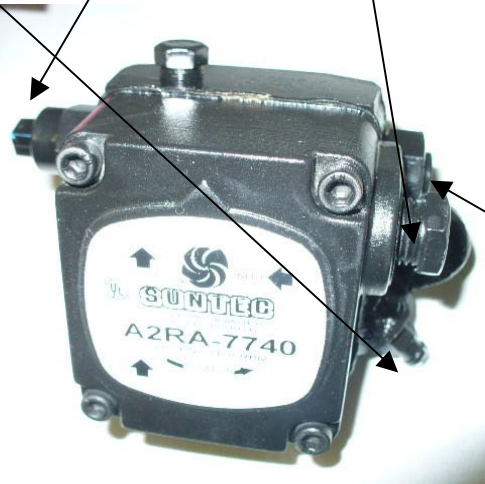

Pressure Adj.

[If Using a CDVF Pump follow instructions in CDVF Manual]

Consult your dealer for the best plumbing arrangement for your heater. There are many ways the plumbing can be done. Use pipe dope on threads, not tape ! Flared tubing & fittings are acceptable, never use compression fittings ! Meeting building codes and your needs may require deviation from the fittings provided in your accessory carton and described in the example below.

Components shown are provided with standard heater purchases and found in Accessory Carton. With new J1000 pumps 1/4x1/8 & 1/2x1/4 bushings provided for use in pump ports.

3/4 FPT Filter Gauges 3/4x1/2 Swivel 1/2 Nipple Pump 1/4 Nipple 1/4x1/4x1/8 Tee

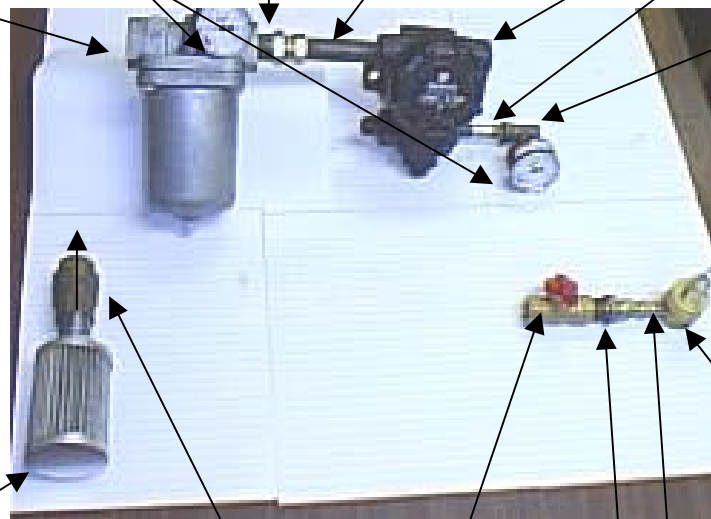

Note Flow Arrow Suction Strainer 3/4 FPT Check Valve 1/2 FPT Valve 1/2x1/4 Swivel Oil Regulator on Burner 1/4 Nipple

Suction Line: Field provides piping from Check Valve to Filter. Note Check Valve has flow direction arrow. Secure piping to keep the Strainer 6"+ off the bottom of the tank. Plan ahead for routine service of components. Use minimal number of fitting to reduce chances of suction leaks. Consult your dealer's experience for methods that work in your application. TIP: It is wise to fill the filters/plumbing on the suction side of the pump with clean oil prior to priming the system. This will minimize priming time and save wear on pump seals.

Pressure Line (Oil Pump Outlet): After the provided Nipple/Tee/Gauge the 1/4" Check Valve may be installed to help keep oil pressure for the burner. The field provides tubing or piping to reach from here to the 1/2" Valve near the Burner. A 3/8 inch or 1/2 inch FLARED (never use compression) soft copper tubing is commonly used. Hard metal tubing or metal pipe is acceptable but may incur more cost, has more potential for leaks, and is not flexible to swing the burner open for routine cleaning. Consult your dealer on sizing for your application.

Try to run the oil piping uphill from the pump to the burner to allow entrapped air to escape at the burner. Avoid high spots in the oil piping or looping the line above the burner as this creates a trap and collects air. Collected air will delay the oil getting to the nozzle, causing a weak flame, slow or failed ignition, or pressure gauge and flame pulsation.

[TIP: spiral or loop some excess tubing at the burner to allow the burner door to swing open w/o having to disconnect the oil line tubing.

Do not connect oil line to Valve at the Burner until after the oil line is purged of dirt and air.
[Suggestion: to ease future oil line purges, adding a tee and drain cock near the burner allows dirt and air to be purged without disconnecting the line from the burner.]

ELECTRICAL CONNECTIONS MODELS 155, 200, 245, 235, 315, 350

All electrical wiring must meet National Electrical Code, N.F.P.A. #70 for furnaces installed in U.S., and C.S.A. Standard C22.1, Canadian Electrical Code, Part 1, for Canada.

Install a panel mounted breaker for single phase 115V max 30 AMP grounded service. Run minimum of 10 gauge wire in metal conduit to the 6" x 6" junction box at furnace. Do this with the power still "OFF". TIP: If the main breaker is far from the heater, installing a manual switch or breaker near the heater may be required by code. It is also handy for cutting main power in an emergency or for servicing.

For field wiring of oil pump and accessories use min 14 gauge wiring.

[**BOLD Print is Field Wiring**]

Main power feed from panel; Hot, Neutral, Ground Prewired Blower Hot, Neutral

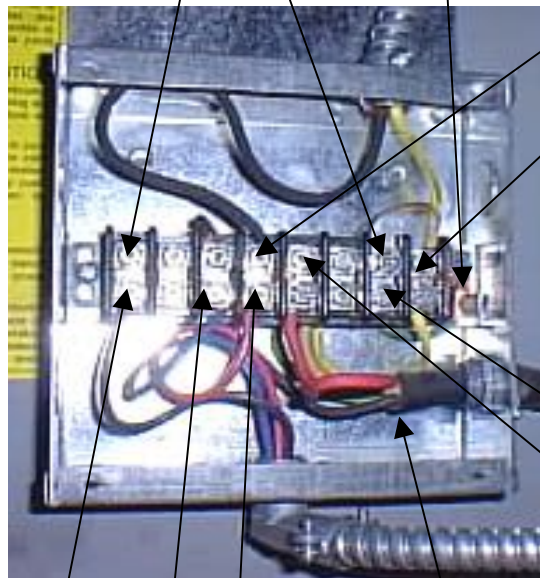

Prewired Fan Limit Black, Blue, and Red
(blue feeds black burner, red feeds blower)

Prewired Burner Cord

Oil Pump Hot, Neutral
(hot is opposite red burner wire)

1. Connect burner power cord coming from junction box to mating connection on burner. Do note force internal moldings, they permit only one orientation of connection. Tighten locking ring to secure. **Run cord through clamp located on top of cabinet, remove slack from burner cord, clamp and secure. This will prevent burner door from swinging open and burner capable of firing. Disconnect molded cord to open door and service burner.**
2. Install the room wall thermostat in work area to be heated. Mount it level or accuracy of settings will be affected. Run 18-2 wire between the thermostat, the snap disc on cabinet, and screws labeled T-T on primary control. Set the room thermostat in the "OFF" position.

APPLIES TO ALL HEATER MODELS EXCEPT MODEL 500

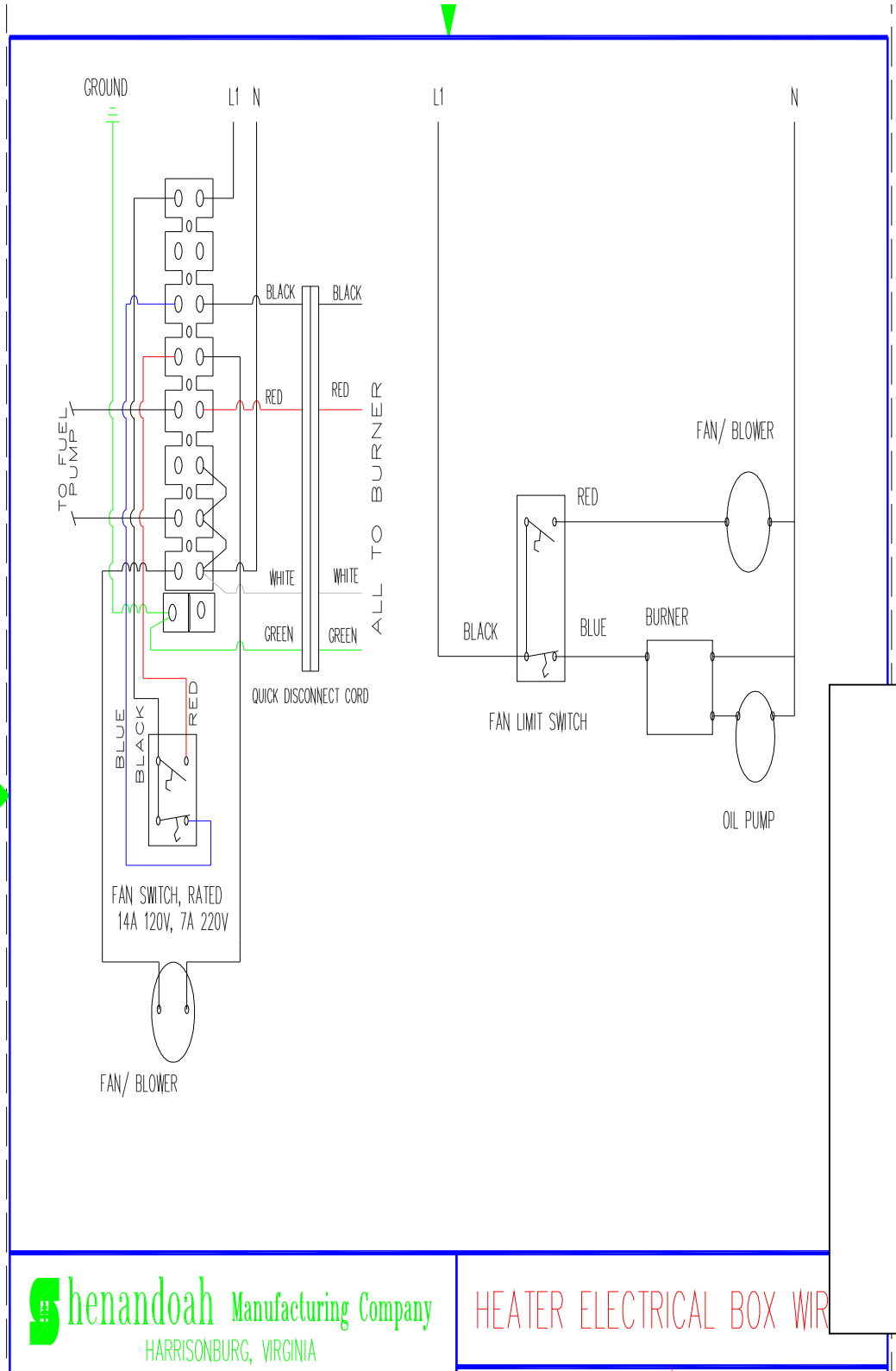

Shenandoah Manufacturing Company
HARRISONBURG, VIRGINIA

HEATER ELECTRICAL BOX WIR

ELECTRICAL CONNECTIONS MODELS 500

Main blower motor(s) are 220 vac. This 220 vac motor power is kept separate from the 120 vac burner and Fan Control by the Power Relay coil. The Power Relay coil is 120 vac and is activated by the RED Fan Control wire. Contacts of the Power Relay carry the two 120vac leads to the 220vac motor(s). Note that some dual blower kits may have the Power Relay mounted in the blower compartment. Slide the large aluminum air filters back to access the components.

[**BOLD Print** is Field Wiring]

Fan Motor leads to unused terminals on relay

Main power feed panel; (2) 120vac Hot feeds, Neutral, Ground

Burner Cord

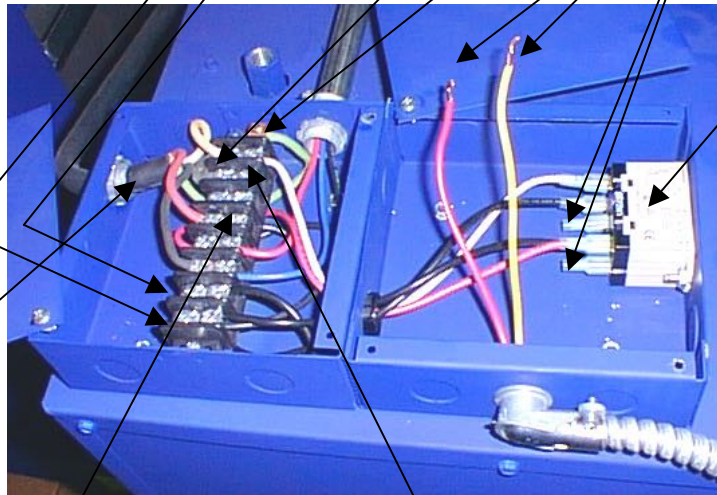

Power Relay

Oil Pump Hot to RED Burner wire, Pump Neutral to any WHITE

Picture is for reference, see following wiring diagrams

COMPLETING WIRING

3. Connect burner power cord coming from junction box to mating connection on burner. Do note force, Internal moldings permit only one orientation of connection. Tighten locking ring to secure. **Run cord through clamp located on top of cabinet, remove slack from burner cord, clamp and secure. This will prevent burner door from swinging open and burner capable of firing. Disconnect molded cord to open door and service burner.**
4. Install the room wall thermostat in work area to be heated. Mount it level or accuracy of settings will be affected. Run 18-2 wire from thermostat to primary control. Connect to screws labeled T-T on primary control. Set the room thermostat in the "OFF" position.

MODEL 500 HEATER ONLY, 220 VAC FEED

220 VAC FEED WITH 120 VAC BURNER

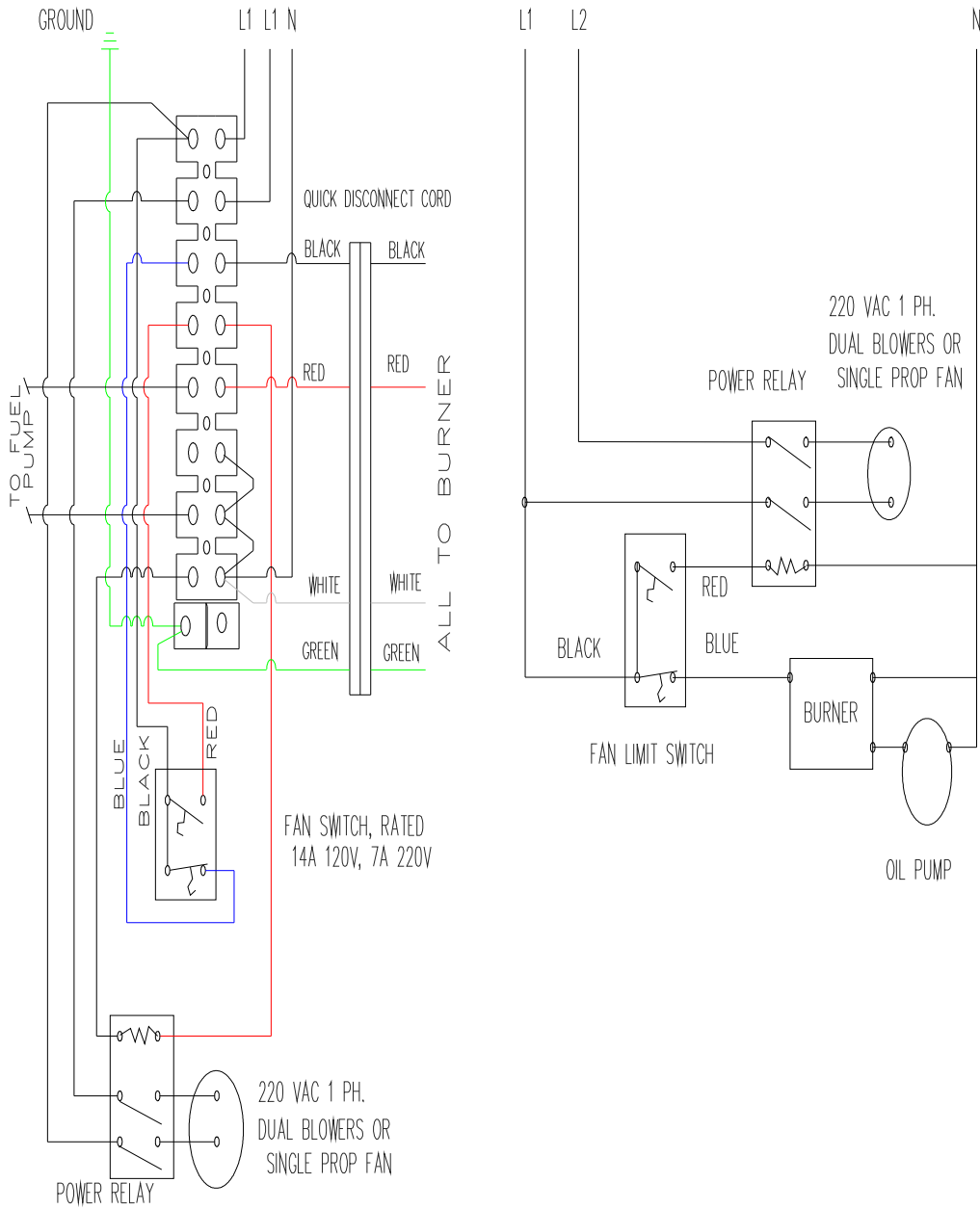

BURNERS

Operating sequences and wiring diagrams follow for each model burner. Burners are factory wired and just need to be field connected to the flexible cord on the heater box. Align quick connect ends properly, slide together, then twist the nut tight.

You need to know which burner you have. Three models are made: K5, B5, B5 Two Stage.

The easiest way to determine is :

Does the burner have an Air Pump & Filter attached at the side of the housing?

YES,

then it is a K5 model burner.
Use "K5" identified diagrams.

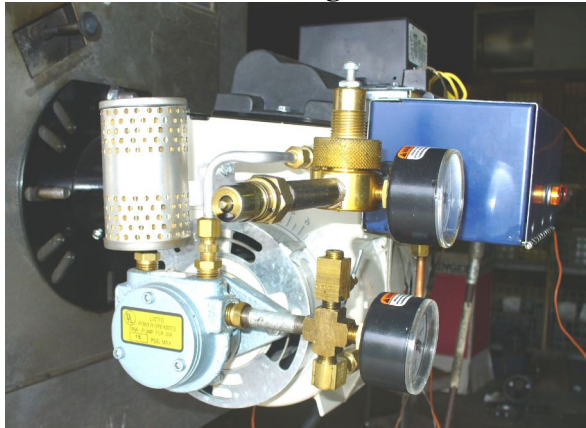

NO,

then it is a B5 model burner.
Two B5 models are made. See below.

The most common is the
standard B5 shown here.



The other burner is a B5 "Two Stage".
It has a Solenoid piped behind the Air
Regulator

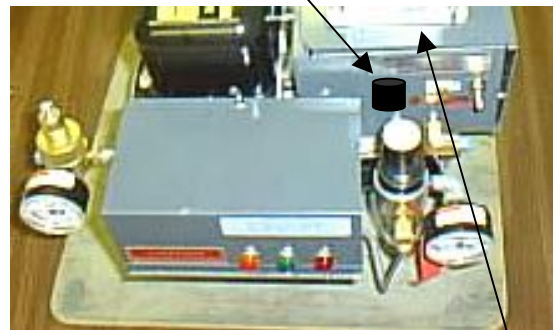

It also has two timers on the underside of the air box lid

INITIAL START UP AND OPERATING SEQUENCE B5 & K5 BURNERS (NOT B5 TWO STAGE BURNERS)

1. Place the 3-position toggle switch on the Burner to "OFF". Energize the heater circuit with electricity. The amber and red lights on the slide gun will come on. Flip the 3-position toggle switch on the Burner to "PRIME". The pump will start. Open the bleed valve on the pump to relieve air, have a shop towel ready, after a few minutes there will be oil and air sputtering from the bleeder. Close the bleeder when oil runs free of air. Oil will now start filling the line toward the burner.
2. Since the oil line is not attached to the burner yet have a bucket ready to catch oil, but be patient. It may take 20 minutes to prime the pump and get oil to the burner.
3. Once the line is filled you will start catching the contaminated oil in your bucket. When the oil is free of air and debris run another few gallons more and close the purge valve or connect the oil line to burner. Flip the 3-position toggle switch on the Burner to "RUN".
4. By now the red light indicating preheating of the oil may have gone off. If it has, turn the wall thermostat to a setting higher than room temperature. The burner will start.
5. The fuel pump, burner motor, igniter starts and compressed air pushes toward the nozzle. When air pressure of 12 psi is achieved at the air proving switch, the air proving switch closes providing power to the oil solenoid valve & green light. The green light comes on indicating the burner is firing, as air in the oil line escapes the nozzle the burner may sputter.
6. Adjust (Needle Valve on K5 burner)(Air Regulator on B5 burner) to have compressed air approximately 13 psi going to nozzle. Air regulator requires the cap to be popped up before twisting knob, push back down after adjusting.
7. The preheated oil and air are mixed at the nozzle and the fuel is atomized as the electrodes arc for ignition. The red light will cycle on/off to automatically to preheat oil in block.
8. Observe flame. A proper flame in Model 155, 200, 245, 315 will extend 1/4 to 1/3 the way down chamber approximately under where the blower is mounted. Three pass heater designs Model 235, 350, 500 will have flame approaching the target wall. **Excessive flame in any heater will damage metal, burn poorly, and void warranty. If an adjustment is needed, take a portable phone to the heater, call your equipment dealer and explain the situation. They will assist you to set oil or air flow for proper flame.**
On non-metering pump heaters to adjust flame loosen nut on brass oil regulator and slightly turn screw while observing flame.
On metering pump heaters they are factory set for oil flow. If you believe the flame is improper advise your dealer, they can confirm you have the proper pump and advise you of options. If there is a brass oil pressure regulator on the burner it is not required when using a metering pump, the regulator may be removed. If the brass oil regulator is left on the burner turn its screw full clockwise to 100% flow, it will then have no affect on oil flow.
9. If a consistent flame is not established during the initial 30 seconds the primary control will lockout.....**Beware some controls will retry ignition after 45 seconds automatically. DO NOT attempt to manual restart a control until the heater has time to cool down and any unburned oil mist has exited the chamber. Forcing a quick restart can put hot oil on the hot surfaces of the heat exchanger and may cause an explosion hazard, or excessive fire leading to personal or property damage.** It is not unusual to lock out one or two times at startup until air and oil have purged through the slide gun.

10. When ignition occurs and combustion is sustained, the heat exchanger temperatures will rise. When 120° F is achieved, the fan limit switch closes, thus starting the blower to push heated air into the room.
11. When the room thermostat is satisfied, the power to the ignition system will be interrupted thus causing the burner to shut down. The blower will continue to operate until the heat exchanger temperature reduces to 90° F at the fan limit switch.

K5 Burner w/ Air Pump, 1 of 2 Burner Drawing

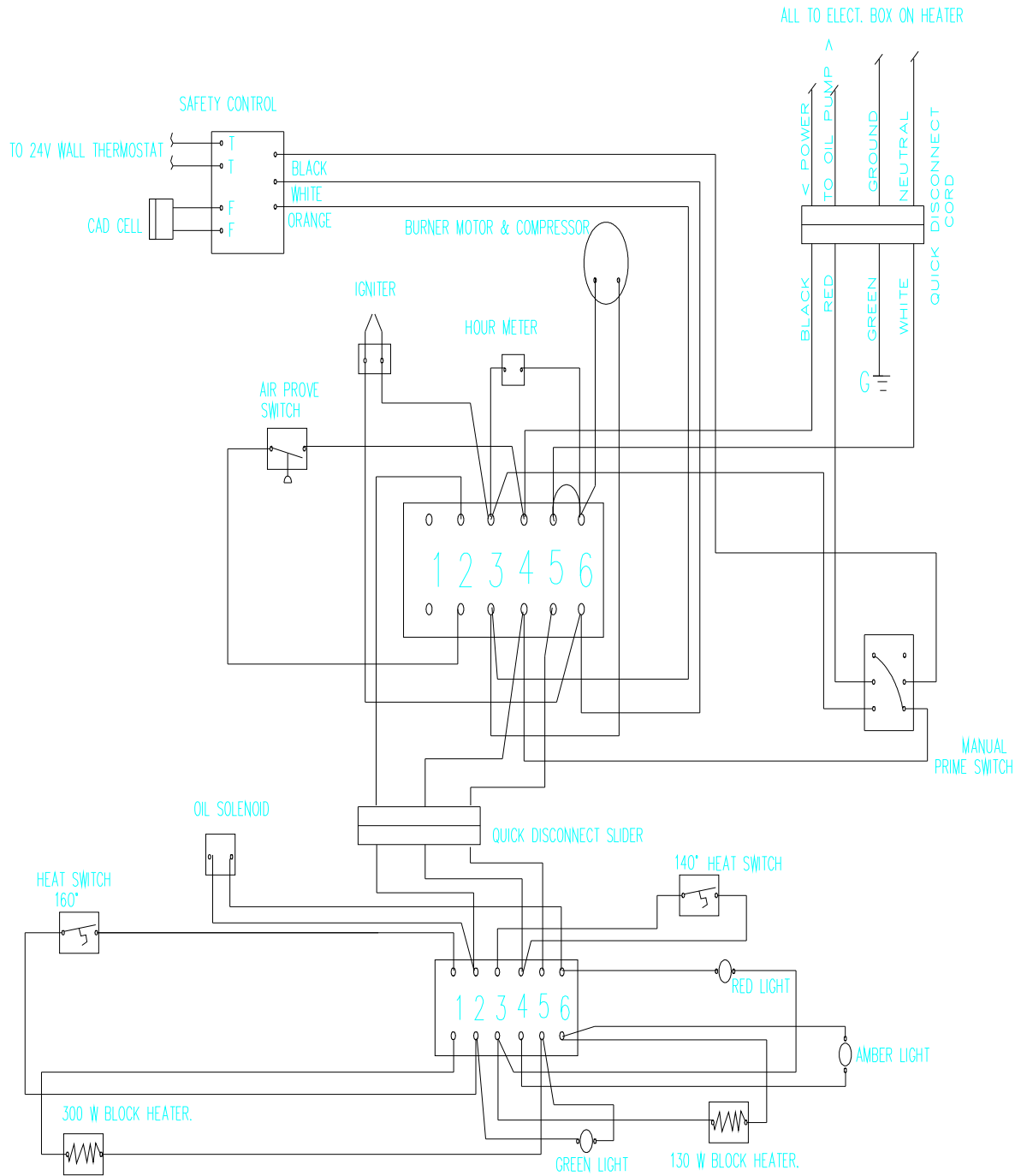

K5 Burner w/ Air Pump, 2 of 2 Burner Drawing

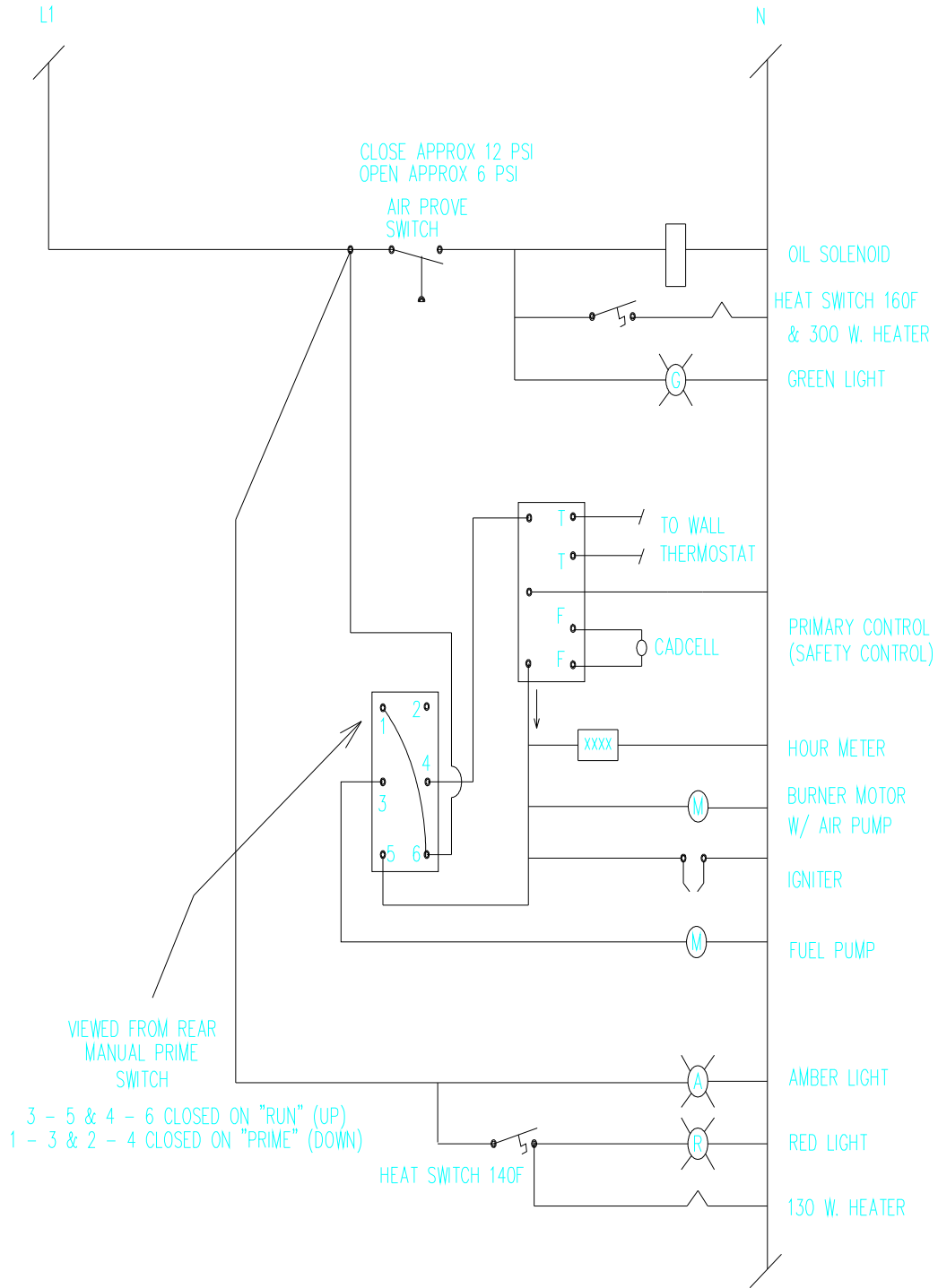

B5 Burner Drawing

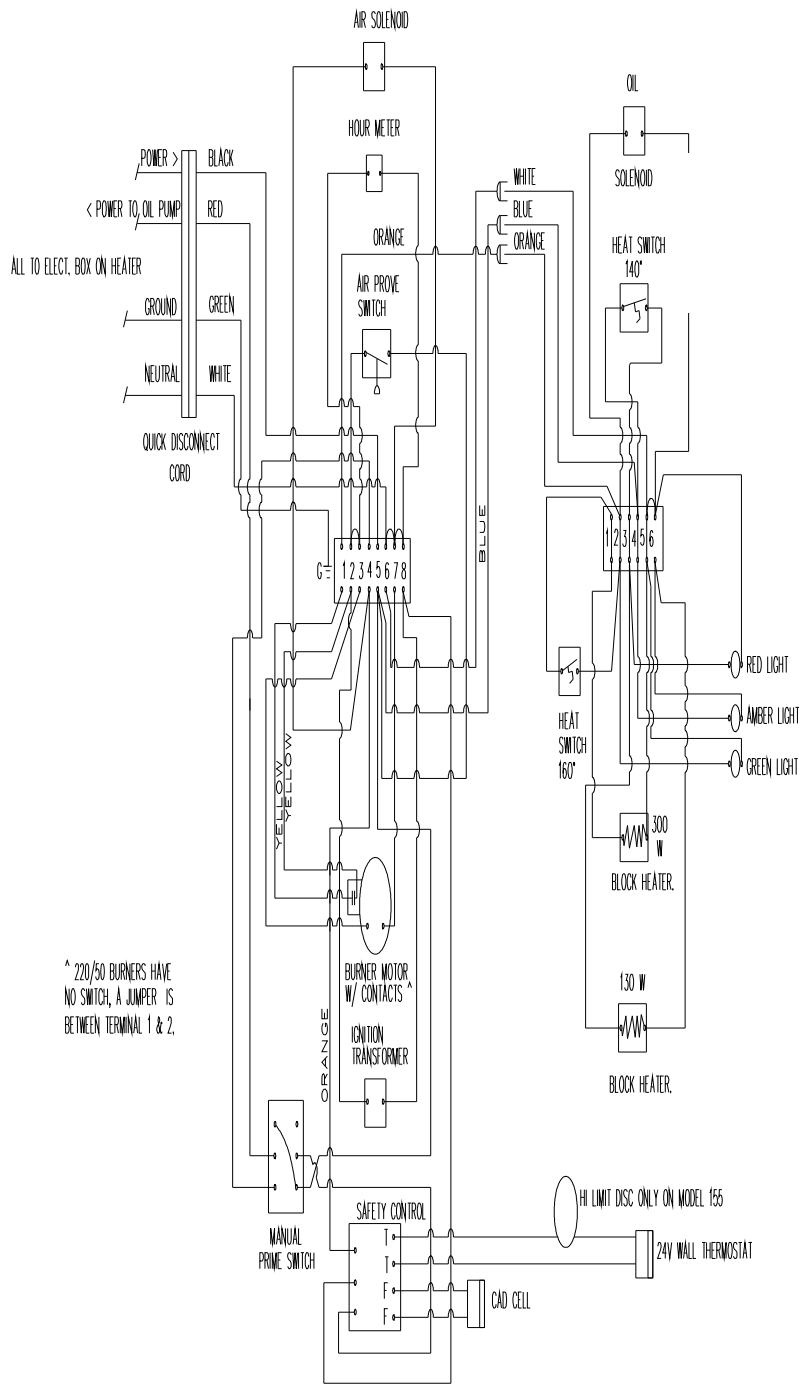

B5 Burner Drawing

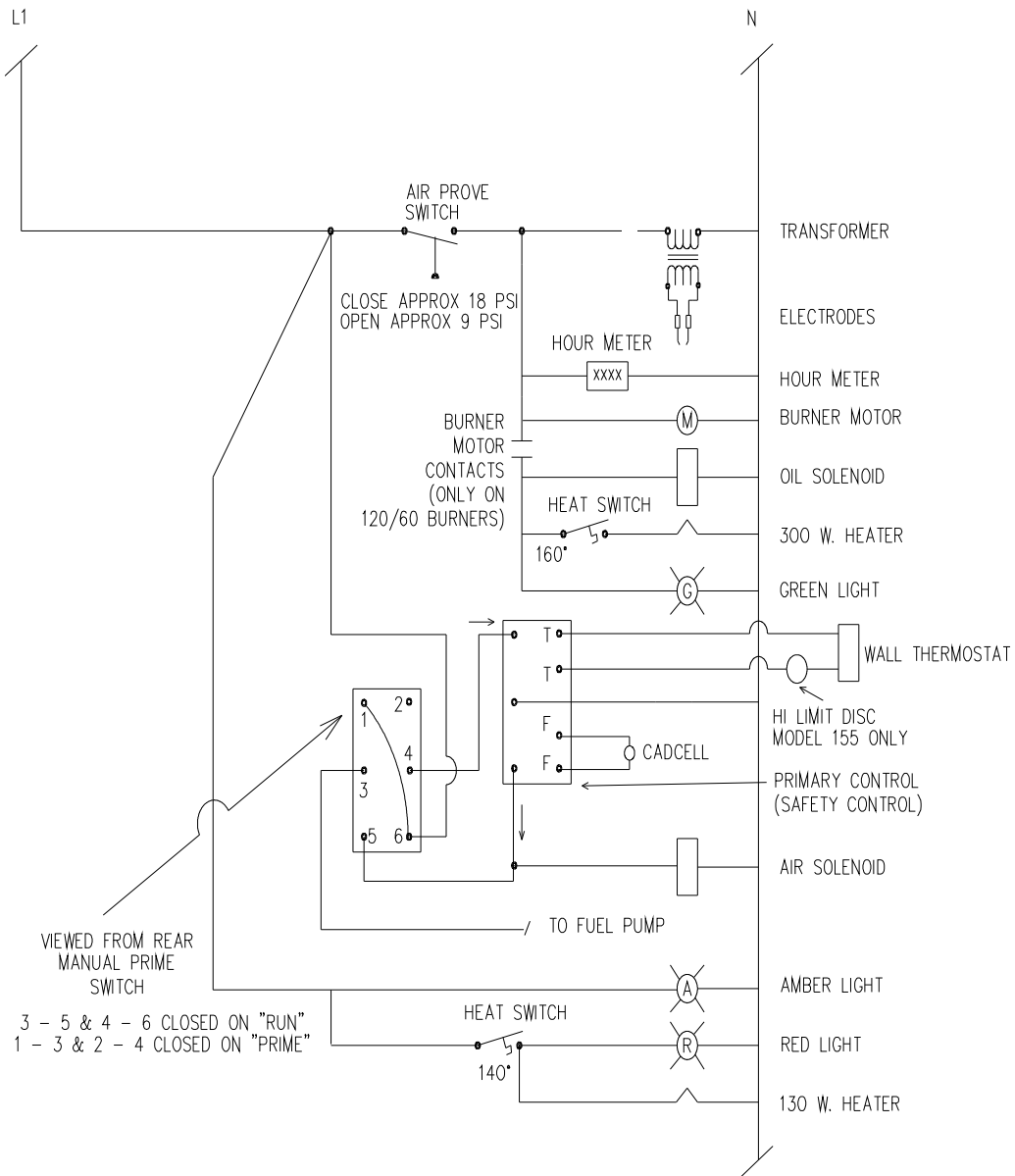

START UP AND OPERATING MODEL B5 TWO STAGE BURNER

1. Place the 3-position toggle switch on the Burner to “OFF”. Energize the heater circuit with electricity. The amber and red lights on the slide gun will come on. Flip the 3-position toggle switch on the Burner to “PRIME”. The pump will start. Open the bleed valve on the pump to relieve air, have a shop towel ready, after a few minutes there will be oil and air sputtering from the bleeder. Close the bleeder when oil runs free of air. Oil will now start filling the line to the burner.
2. Since the oil line is not attached to the burner yet have a bucket ready to catch oil, but be patient. It may take 20 minutes to prime the pump and get oil to the burner.
3. Once the line is filled you will start catching the contaminated oil at the burner in your bucket. When the oil is free of air and debris run another few gallons more and close the purge valve or connect the oil line to burner. Flip the 3-position toggle switch on the Burner to “RUN”.
4. By now the red light indicating preheating of the oil may have gone off. If it has, turn the wall thermostat to a setting higher than room temperature. The burner will start.
5. The burner motor and 2-stage air solenoid do not activate. They are delayed for three seconds by the first timer/relay.
6. A bypass circuit for the burner motor centrifugal switch is established for six seconds by the second timer/relay. The oil solenoid, 300 Watt heater, and green light receive power through the second timer/relay. Once the burner motor starts it has three seconds to close its centrifugal switch to establish power to the oil solenoid, 300 Watt heater, and green light. If the centrifugal switch fails to close, the oil solenoid, 300 Watt heater, and green light will lose power after six seconds when the second timer deactivates.
7. Air flow through the burner head toward the flame target (Remember the burner motor is not on to do this) is desired to have best ignition. This may be provided by natural or induced draft. If this air flow is not present the burner may not light consistently or hesitate and puff smoke out the viewpoint. If there is a ignition problem, never look directly through or stand in front of the viewpoint. Any pressure buildup will vent through the path of least resistance, the view port and stack. Never keep resetting the Primary Control if the flame fails to ignite. This could create a unsafe condition leading to excess oil in the fire chamber.
8. The air regulator on the burner should be adjusted to allow approximately 16 psi going to the nozzle while the burner is in full operation. At startup it is normal for the burner air gauge to climb to 10 psi, hold there for three seconds, and jump to 16 psi after the 2-stage air solenoid coil is energized. If greater than 12 psi is attained during the first three seconds a reduction in the air pressure coming to the burner is recommended.
9. The 2-stage air solenoid has a special orifice in it to allow air to pass through at a controlled

rate prior to being energized (opened). This feature allows a slow three second increase of air pressure from 0 to 12 psi going to the nozzle. This is when a soft flame is established. After the coil is energized (opened) the full flow of compressed air will flow to the air regulator and 20 psi is sent to the nozzle for a more intense flame.

10. Opening the combustion air bands is acceptable for clean combustion of the fuel. This will create a shorter and brighter flame. Open the bands only enough for a clean flame. Excessive air will cause irregular ignition or blow out flame.
11. Observe flame. A proper flame in Model 155, 200, 245, 315 will extend 1/4 to 1/3 the way down chamber approximately under where the blower is mounted. Three pass heater designs Model 235, 350, 500 will have flame approaching the target wall. **Excessive flame in any heater will damage metal, burn poorly, and void warranty. If an adjustment is needed, take a portable phone to the heater, call your equipment dealer and explain the situation. They will assist you to set oil or air flow for proper flame.**

On non-metering pump heaters to adjust flame loosen nut on brass oil regulator and slightly turn screw while observing flame.

On metering pump heaters they are factory set for oil flow. If you believe the flame is improper advise your dealer, they can confirm you have the proper pump and advise you of options. If there is a brass oil pressure regulator on the burner it is not required when using a metering pump, the regulator may be removed. If the brass oil regulator is left on the burner turn its screw full clockwise to 100% flow, it will then have no affect on oil flow.

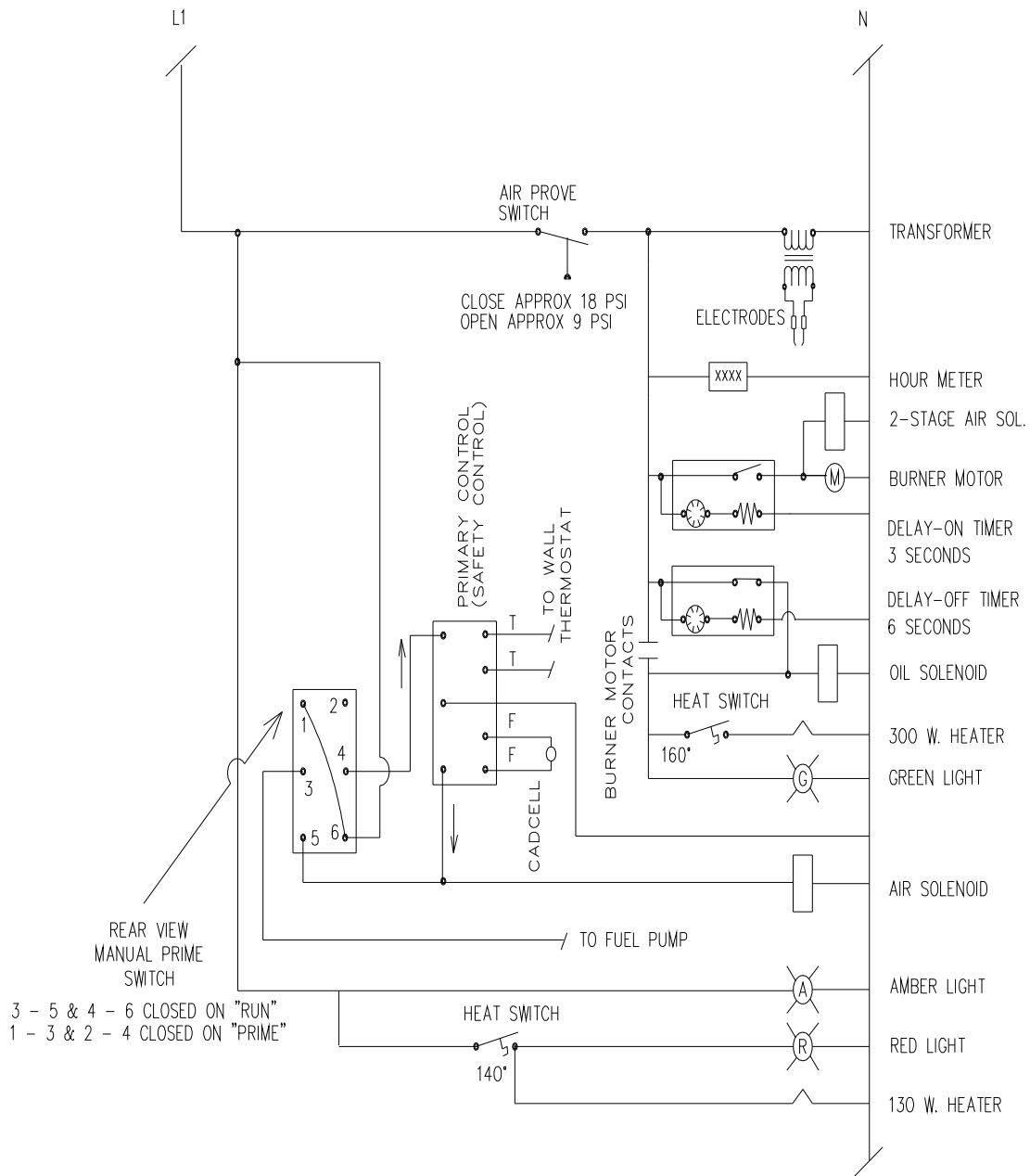

120 VOLT MODEL B5 TWO STAGE (w/AIR DELAY) BURNER WIRING

HAS EXTRA AIR SOLENOID AND TIMERS

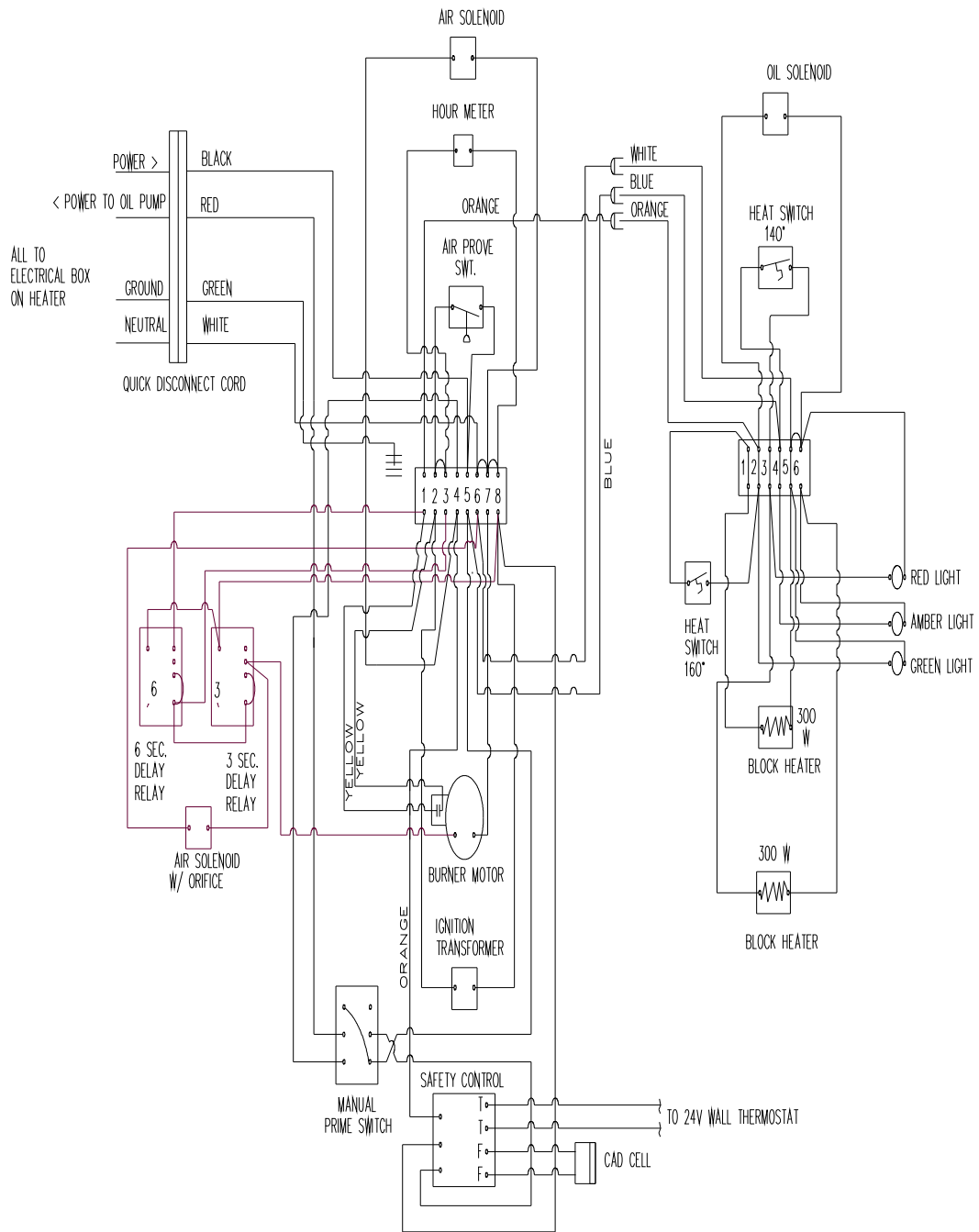

120 VOLT MODEL B5 TWO STAGE (w/AIR DELAY) BURNER WIRING

HAS EXTRA AIR SOLENOID AND TIMERS

FAN LIMIT SWITCH SETTINGS

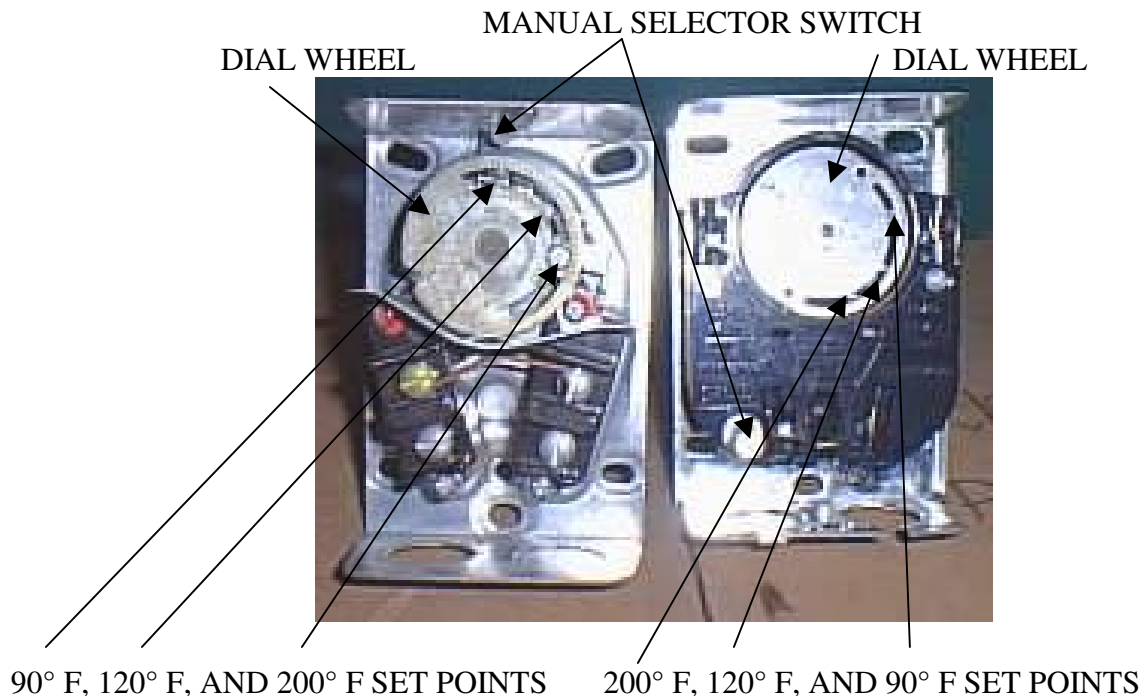

Similarly operating White Rogers and Honeywell fan limit controls respectively shown above. The manual selector switch should be at **AUTOMATIC** for heating applications. **MANUAL** setting can be used for constant air circulation with or without burner operation.

1. As the burner fires the heat exchanger temperature rises. The fan control starts the blower motor at 120° F and sends heated air into the room.
2. After the burner cycles off the heated air will gradually cool to 90° F, the fan limit switch will open and cut power to the blower motor.
3. If there is a malfunction and the heated air reaches 200° F, the control will cut the burner's power (amber light goes out) but the blower will continue to run trying to cool the exchanger. This is a problem that needs corrected. It may be due to excessive restriction of heated air from the heater, a failed blower motor, obstructed blower inlet, or too much oil being fired in the chamber. Once the heated air is cooled sufficiently the burner will be allowed to get power again (amber light on) and fire. This process will cycle repeatedly until the problem is corrected or the room thermostat stops calling for heat
4. The 90°F and 120°F settings can be adjusted if there is unusual cycling of the blower. To maintain warranty, consult your dealer on how to do this and get the flame sized properly.

If resetting of tabs is needed, hold dial wheel still or force from rotating will damage coil.

FINE TUNING THE BURNER

OBSERVE THE FLAME DAILY. ALLOWING HEATER TO OVER FIRE WILL DESTROY THE HEAT EXCHANGER AND VOID THE WARRANTY. UNDERFIRING MAY LEAD TO CONDENSATION AND RUST THE CHIMNEY OR HEATER.

Due to variations in used oils, the air and oil pressure gauge setting are approximate. Final adjustments need to be made with your specific fuel. Observe the flame pattern through the observation port and make all adjustments while observing the flame.

1. The ideal flame is bright yellow/white in color, no visible smoke emitting from the chimney.
2. If the flame appears dull yellow and red in color, it is fuel rich and oxygen starved. Open the air shutter on the side of the burner or reduce oil flow. Metering Pumps are factory set, no adjusting is available.
3. Combustion air is admitted through the adjustable air bands on the side of the burner. On models over 200,000 btu start with air band closed and face pointer at #10. On models under 200,000 btu start with air band closed and #5 for the face pointer. Add just enough air to allow clean combustion. Excess secondary air will reduce efficiency, choke draft, make ignition more difficult and possibly pulse or back pressure the chamber.
4. The draft and the combustion air required for clean burning, smooth ignition, and efficient combustion is proportional to the fuel flow rate. DO NOT exceed -.08 inches water column draft at the breech.
5. The fuel flow rate is controlled by nozzle size and oil pressure. If the flame is not clean or too large with oil pressure less than 2 PSI, replace the nozzle, it may have worn-out or a smaller nozzle may work better at slightly higher pressure. Metering Pumps are factory set, no adjusting is available.

PRIMARY CONTROL FUNCTION - SAFETY LOCKOUT

CAUTION: DO NOT PUSH THE RESET BUTTON IF THE BURNER FLAME FAILS AND THE FURNACE CHAMBER IS HOT! FORCING A REFIRE TOO SOON MAY PUT FUEL INTO THE HOT COMBUSTION CHAMBER AND CAUSE AN EXPLOSION HAZARD. SOME CONTROLS HAVE A AUTOMATIC RETRY FOR IGNITION AFTER 45 SECONDS. BEWARE THAT THIS CAN HAPPEN. DISCONNECT ALL POWER BEFORE SERVICING OR THE BURNER COULD ATTEMPT A REFIRE AT A UNWELCOME TIME. A SHOCK OR BURN HAZARD COULD OCCUR.

When the primary control locks out there is a malfunction. **Determine the cause.** The primary control is a safety device similar to a breaker in an electrical circuit. It will lock out when:

1. The cad cell (electronic eye) detects a reduced, dirty, or no flame for many seconds. A signal measured in ohms is communicated between the cad cell and the primary control. A poor or absent flame produces a high ohm reading. When this signal is > 1500 ohms the control may go into reset. A signal indicating a very good flame is < 500 ohms. A moderate flame would be 500 to 1000 ohms.
2. The cad cell has failed, lens is dirty, or retention head is dirty.
3. The retention head fins are not allowing light to pass to the cad cell.
4. The cad cell receptacle is not making good contact with the cell eye.
5. The primary control is defective allowing the reset button to pop too easily.
6. The control is located in a high ambient temperature like a furnace mounted in a alcove or small room that is retaining heat.
7. Once the chamber has cooled the control can be reset by depressing the red button for 5 seconds and releasing. Ignition will be attempted immediately if the wall thermostat is looking for heat.

ROUTINE HEATER AND BURNER MAINTENANCE

Weekly Maintenance

A flame inspection mirror is useful for a routine check of the nozzle, ignition, and retention head while the unit is operating.

1. Observe flame--adjust if needed.
2. Check all filters and water traps in the oil and air supply lines. Clean if needed.
3. Check barometric damper draft setting and be sure flap has freedom to move.
4. Inspect chimney integrity at elbows, tees, fire-stops, roof cap.

Be prepared to clean the exchanger and burner head area and nozzle every 500 to 2000 hours

Heat Exchanger

A properly cleaned & maintained furnace operates efficiently and prevents possible soot fires. A clean flame and good draft will allow longer intervals between cleanings.

To clean the exchanger remove the stack outlet cap. Disconnect burner electrical cord from burner. Disconnect oil line if it is not flexible and hinge burner door open by removing two nuts at corners of door – be careful with fragile door gasket. Use cleaning rod with hoe/brush end to move ash to ends of exchanger. Scoop or vacuum ash from exchanger. Remove stack sections as needed to get ash from inside of chimney. Horizontal runs will collect ash and create draft problems if not cleaned regularly.

CAUTION: Used oil may contain heavy metal compounds and foreign materials. When burned, the compounds are deposited in the furnace and chimney. Protective clothing, including gloves, face mask, and respirator must be worn when cleaning is done. All waste materials removed when cleaning the system should be stored in a closed noncombustible container until properly disposed. Do not store rags or cleaning solvent materials near the furnace, this is a fire hazard.

Burner

While burner door is open clean retention head and igniters. Using a torch to heat retention head and electrode tips can harden the buildup and make removal easier with a brush. Be sure not to damage shape of electrodes or fins.

Remove the nozzle with a 5/8 socket and disassemble it into 3 pieces. Clean thoroughly and reassemble. Be sure small distributor is seated properly in the ferrule or the cap will mash it when screwed on.

Another option to clean the nozzle is to remove the slide gun assembly from the burner.

1. Disconnect air line from underside of slide gun using 1/2 inch wrench.
2. Disconnect oil line if it is not flexible.
3. Loosen mount screw on left side of burner to free slide gun from housing.
4. Pull slide gun assembly straight back from burner, this disconnects the electrical as it is withdrawn from air box housing. Secure slide gun in vise by capturing the aluminum block.
5. Remove nozzle and disassemble into three pieces. Clean with solvents and soft cloth. If wear is evident install a new nozzle. Wear may be from burn marks from igniter arcing or abrasion by oil flow that enlarges the orifices.
6. Inspect o-ring; replace if worn, torn or deformed.

ASSEMBLY OF NOZZLE

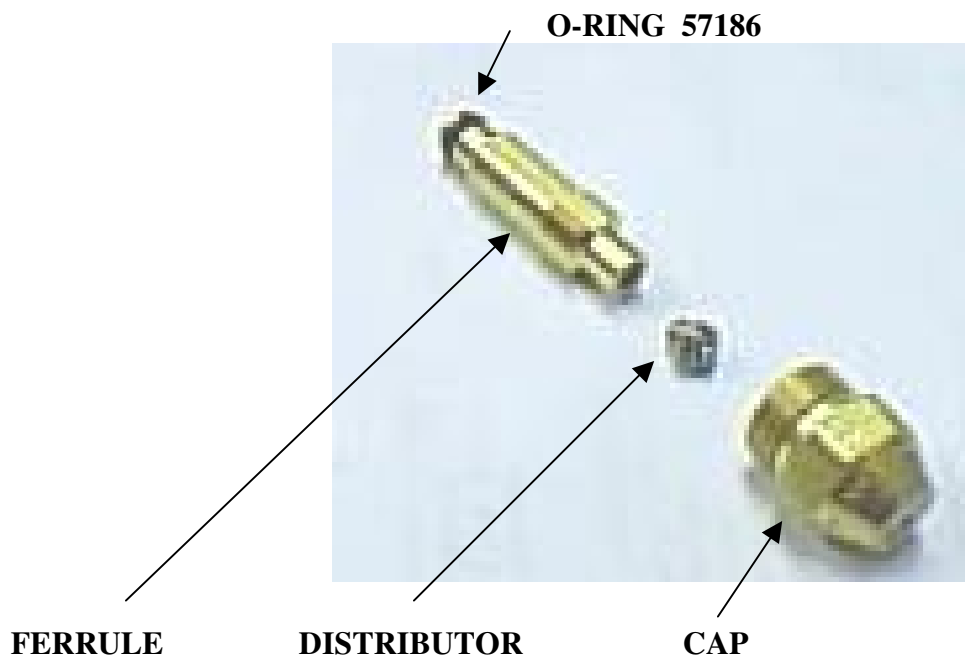

<u>NOZZLE</u>	<u>SIZE</u>	<u>FOR USE WITH</u>
57103	9-1	MODEL 155
57105	9-5	MODEL 200, 235, 245, & 315
57106	7-2	MODEL 350
57108	9-11	MODEL 500

For a more thorough service the following burner components can be cleaned as a preventative yearly maintenance.

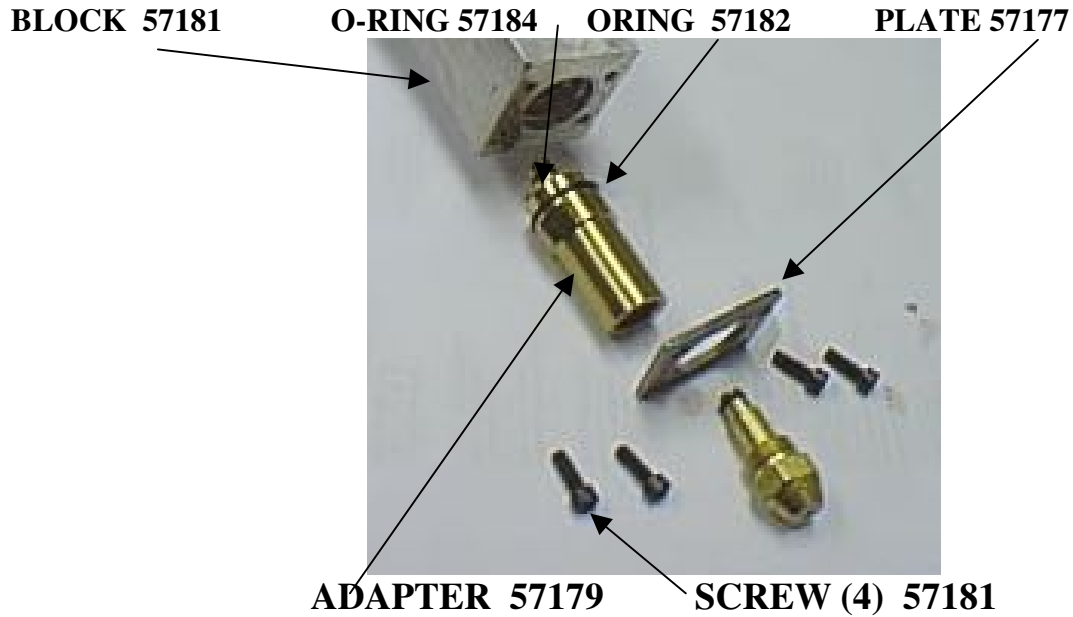

ASSEMBLY OF OIL AND AIR SOLENOID #57190

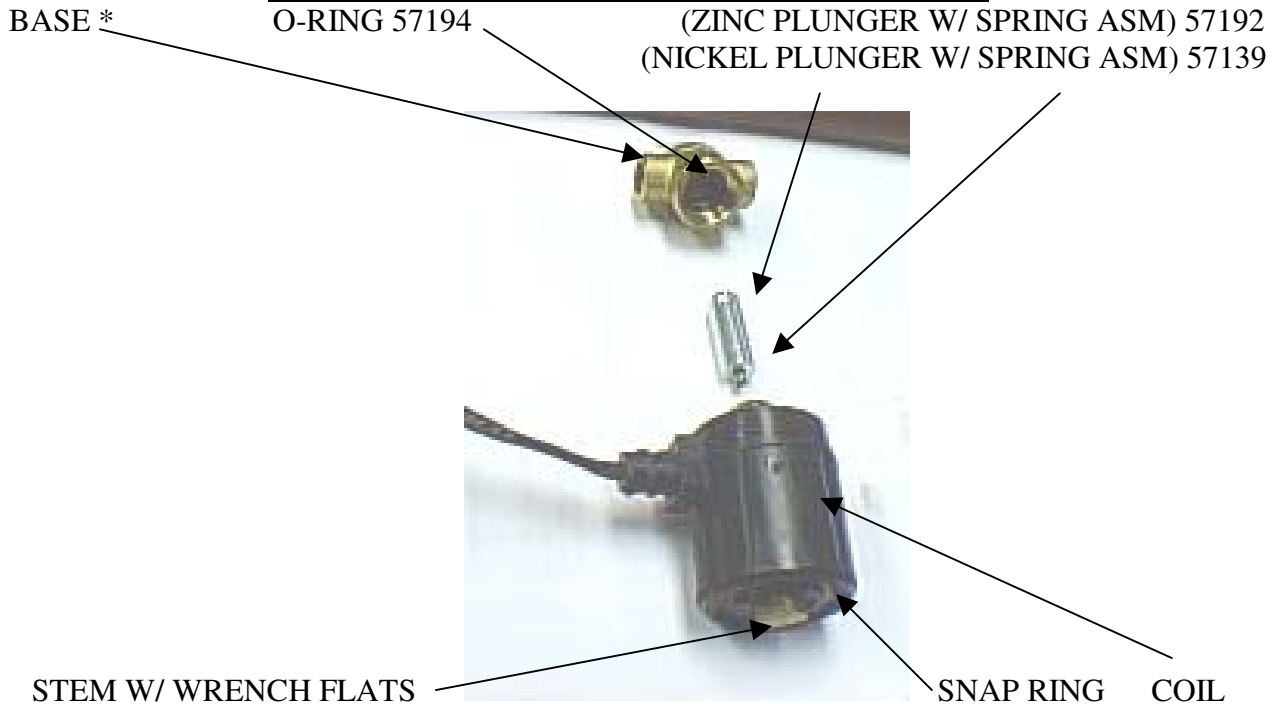

*** Pay attention to detail, the solenoid base has a specific inlet and outlet direction.**

ASSEMBLY OF SPECIAL MODEL 500 AIR SOLENOID #57185

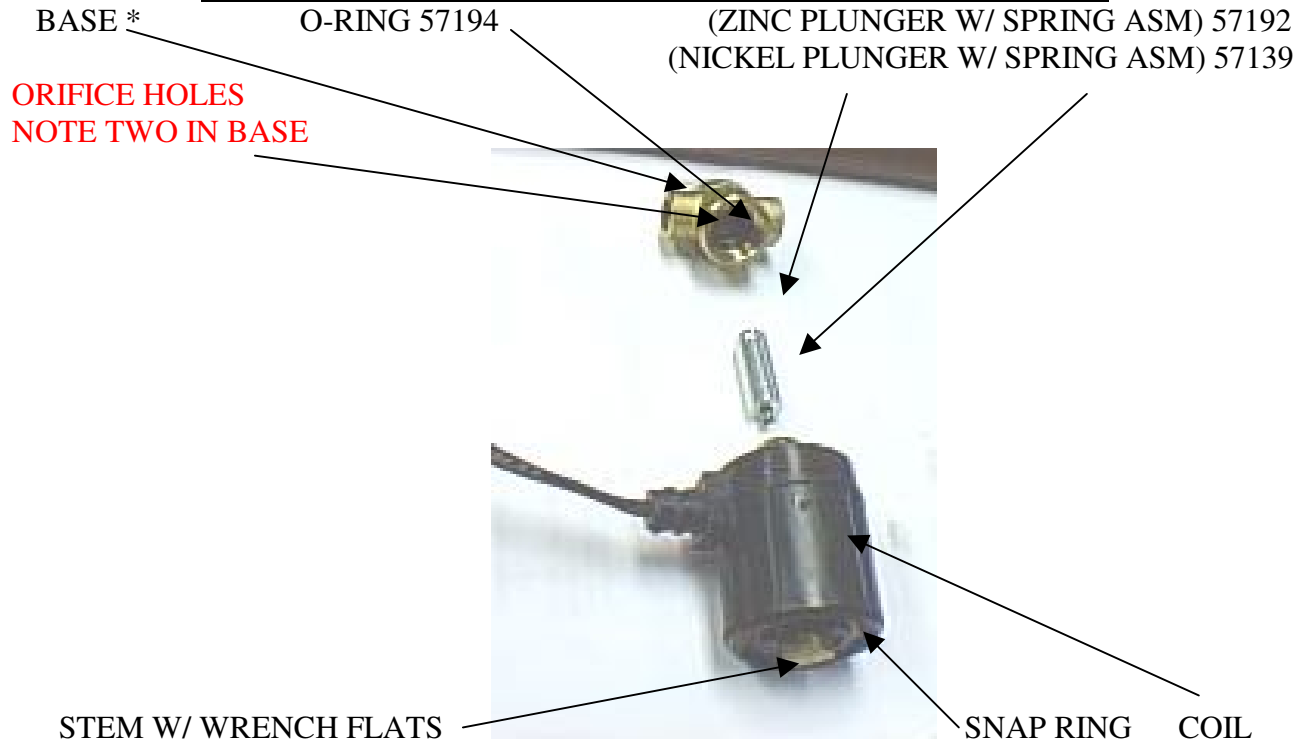

* Pay attention to detail, the solenoid base has a specific inlet and outlet direction.

ASSEMBLY OF OIL REGULATOR #57129

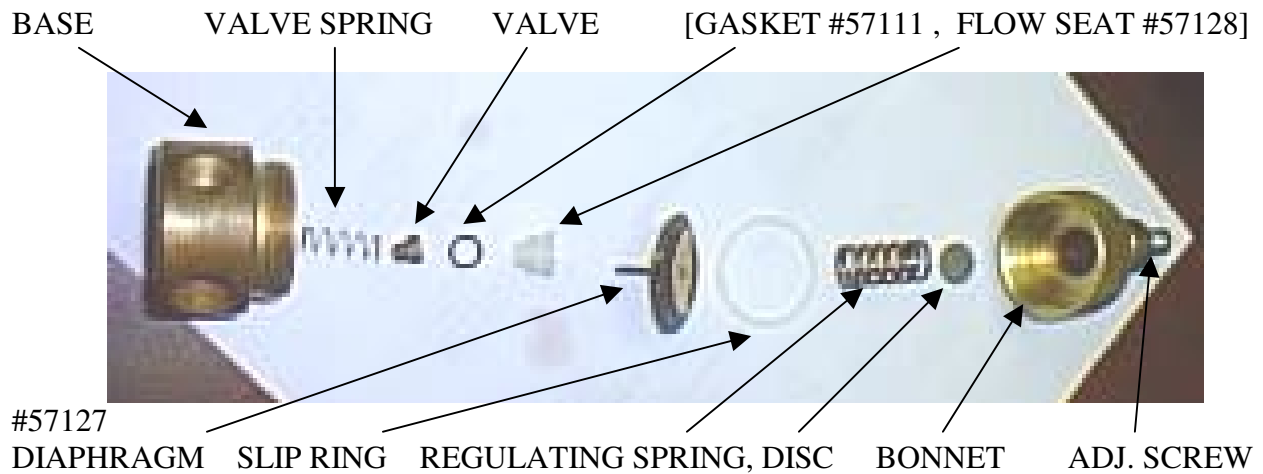

For a more thorough service the aluminum preheat block can be cleaned. The need to increase oil pressures to maintain a good flame is a indicator block passages may be restricted. How quickly a block becomes restricted varies with hours of use and oil quality. Block cleaning is a skilled service that inexperienced persons should not undertake. Improper methods could damage threads or passageways. Consult your dealer if you think this operation is needed on your burner.

ALUMINUM PREHEAT BLOCK

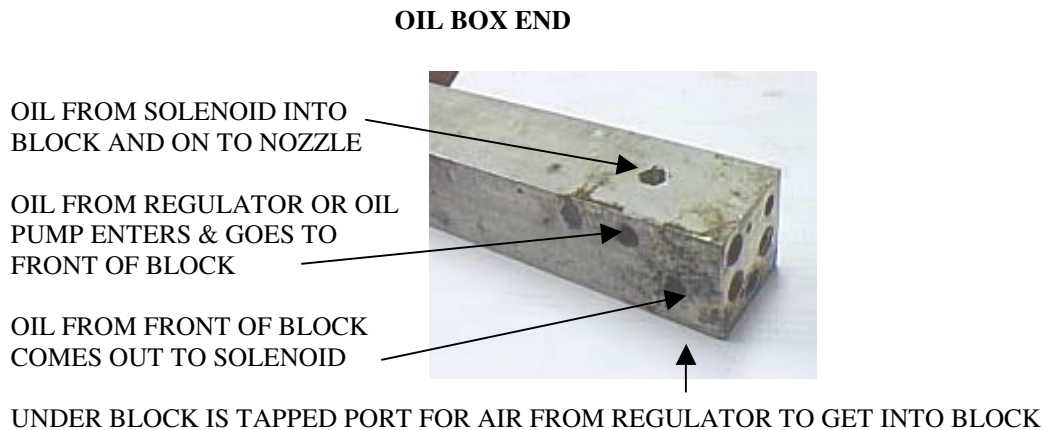
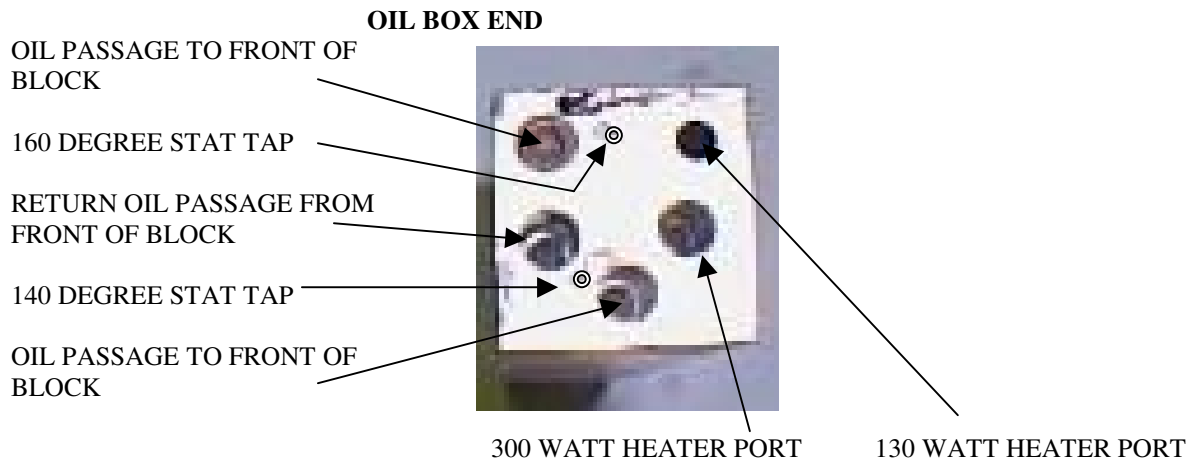
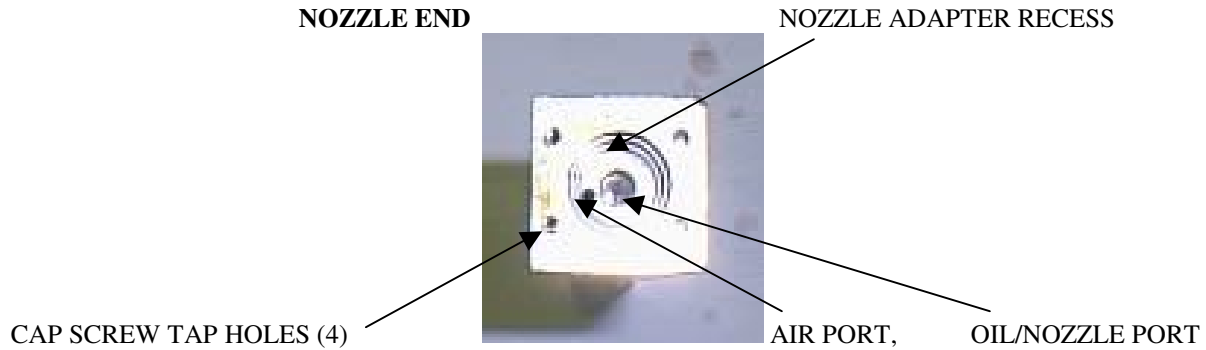

END OF HEATING SEASON/SUMMER STORAGE

Consult your Dealer, they can give advice on proven methods.

1. Turn off power to furnace and set room thermostat to "off".
2. Clean furnace and chimney thoroughly. See previous sections for details.
3. Spray interior of combustion chamber with light oil to protect against corrosion.
4. Separate electrical disconnect cord to burner. Remove oil and air lines. Take burner to work bench. Clean burner nozzle, electrodes, head and other burner parts. Replace any worn parts as needed. Replace burner on heater so it will be ready for next season. Some users flush burner with #2 fuel oil or kerosene before shutting it off for the season.
5. Service oil tank screens and filters and screen in head of pump. Pump gaskets are fragile so have a spare gasket available.
6. Flush oil pump with #2 fuel oil or kerosene. Reassemble pump.
7. Drain water and sludge from fuel tank.

Start up procedures for the new heating season is the same as a initial start up. Following these tips will help assure a longer life of the heater, and will be ready for the next heating season.

**For your safety switch off power supply before servicing.
Only qualified persons should service equipment.**

TROUBLE – SHOOTING GENERAL

Burner Fails To Ignite

A flame requires three components: 1. fuel 2. spark 3. air .

Success will come from determining which are not present and how to fix them.

1. Check oil pressure, it should hold constant and not fluctuate or drift up and down.
2. Be sure a spray of oil is going into chamber, if not, find obstruction. Cleaning the nozzle, oil solenoid, or regulator may be required. A fine mist can look like adequate oil is being sprayed but there may be inadequate volume to establish a flame. Determine whether the fuel supply is combustible. Antifreeze, paint, or water may have entered the oil lines.
3. Check oil filters in line. All filters in the oil line need to be checked and cleaned periodically. They will become blocked with continued use and slowly restrict oil flow.
4. Inspect check valve to see if they open as expected and in the proper direction. Check strainer in the oil tank for dirt. Check strainer in pump head for blockage but have replacement head gasket available as the gaskets are fragile.
5. Check for spark at electrodes. Check for proper gap, for shorting to nozzle or head. Be sure igniter is receiving power and creating voltage for a arc. Electrode tips should be free of carbon and ash buildup. Tips should diverge to fan the arc over the nozzle.
6. Check air pressure and volume in supply line. Starting pressure should be about 13 PSI but not fluctuate wildly or drift up and down. A falling air pressure or inability to adjust to higher pressure can indicate inadequate volume of air supply.
7. Check for condensation in compressed air line. Air solenoid could be sticking or air proving switch stuck in open position. This would keep power from igniter, burner motor, and oil valve. Indicator would be green light does not come on.

Fluttering Or Pulsating Flame

1. Vacuum leaks in oil pump or suction line. A dancing gauge pressure is good indicator.
2. Excessive combustion air or damaged, abnormal shaped retention head.
3. Dirty or plugged fuel filter. Dancing or low vacuum pressure is good indicator.
4. Nozzle or adapter o-rings in nozzle assembly defective, allowing bypass. If adjusting burner's air regulator pressure up and down between 0 and 15 psi will cause oil pressure to change with it the o-rings may not be sealing.
5. Water or antifreeze in the fuel. Confirm the fuel is combustible and consistent.
6. Condensation in the compressed air supply not delivering consistent air volume.

Flame Failure

1. Obstruction in nozzle, air or oil solenoid, or air or oil regulator - clean or replace. Having to operate at higher than normal pressures is indication.

2. Fuel pump not operating, coupler loose, bypass in pump stuck open.
3. Water, paint, or antifreeze in oil.
4. Failure of pre heater(s) in slide gun assembly. Slide gun underside should feel warm.
5. Electrodes improperly adjusted, broken, shorting, or ash covered.
6. Centrifugal switch in model 500 burner motor failing (green light flickers or never on).

Primary Control Locks Out On Safety

1. The cad cell (electronic eye) detects a reduced, dirty or no flame for over 30 seconds. A signal measured in ohms is communicated between the cad cell and the primary control "F – F" connections. A poor or absent flame produces a high ohm reading. When this signal is > 1500 ohms the control goes into reset. A signal indicating a very good flame is < 500 ohms. A moderate flame would be 500 to 1000 ohms. Contact your dealer for details on reading ohms at the safety control.
2. The cad cell has failed, lens is dirty, or retention head is dirty.
3. The retention head fins are not allowing light to pass to the cad cell.
4. The cad cell receptacle is not making good contact with the cell.
5. The primary control is defective allowing the reset button to pop too easily.
6. Exhaust fan in building reverses draft in chimney, or cold building at night creates down draft. The flame smokes on startup due to lack of proper draft and trips reset.

Smoke On Ignition

1. Oil flow too great--adjust flow downward.
2. Air pressure too low (set approximately 13 psi and adjust as needed).
3. Down draft, or improper draft adjustments, check barometric damper regulator. Install a draft inducer if reverse draft is present due to cold building or exhaust fans.

Heater Cycles On and Off Due to High Limit on Fan Switch

1. Indicator is the amber light cycles on & off. Causes may be: oil pressure is set too high and burner over fires, blower is restricted, or louvers are restrictive, or fan switch is failing. Check for air flow restrictions and set flame to proper size. Correct before damage is done to exchanger or chimney.

Poor Draft

1. Confirm there is -.04 to -.06 inches water column at breech of exchanger.
2. Firebox, flue outlet, or stack is plugged with ash.
3. Exhaust fan in building reverses draft in chimney.
4. Cold building at night creates down draft in chimney.
5. Height of chimney insufficient or pipe cap plugged or blown off.
6. Lack of make up air for combustion.
7. Install a draft inducer if reverse draft is present due to cold building or exhaust fans.

Trouble Shooting – Fan Control

NOTE JUMPERS STAY IN PLACE



BLACK, BLUE, RED WIRE

RED, BLACK BLUE WIRE

Wires should be in proper location, secure, and probe/dial free to turn.

PARTS REPLACEMENT IDENTIFICATION

BLUE CABINET MODEL 155

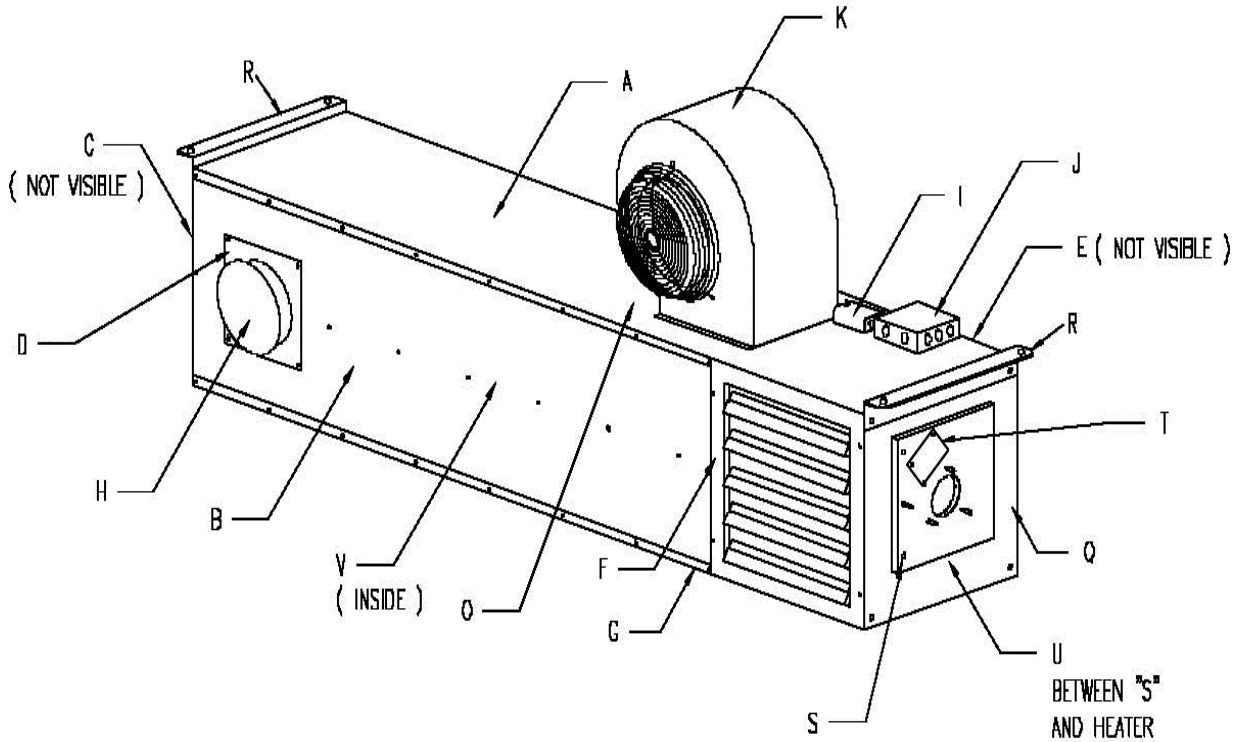

BURNER AND CORD OMITTED FOR CLARITY

Key	Part Number	Description
A	11240	CAB: Mdl 155 Top
B	11239	CAB: L or R Side
C	11430	CAB: Stack End, Mdl 155
D	100501	CAB: Stack Outlet Cover Donut
E	11437	CAB: Blank Filler Panel for 155
F	102309	CAB: Louvers(4)+ Panel Kit for 155
G	11242	CAB: Base for 155
	102358	Louver w/bolts for 155 / Each
H	102359	Stack Cap
	11230	AIR DEFLECTOR "U" SHAPE
	56803	PAINT: SPRAY 12OZ BLUE REFLEX
I	56419	SWITCH: FAN 5 IN UOF

J	56955	Juction Box (6"x6")
	57266	STRIP: TERMINAL 8 POLE 30 AMP
	57407	MOTOR: BLower MOTOR w/cap
K	11101	Blower Wheel & Housing for 155 &200
O	101140	Blower Guard for All , /Each
	11103	Left Blower Housing Leg for 155 & 200
	11104	Right Blower Housing Leg for 155 & 200
	11107	Rubber Bushing for Leg/Each
	56426	Motor Capacitor
	13142700	MT: CAPACITOR
	56421	Motor Capacitor 15 UFD
R	102200	Mounting Brackets: Each 155 & 200 (2 needed)
S	102365	Burner Door w/ internal Viewtube
T		No longer available
	11932	Cab: Painted Skin for Burner Door
	11124	Handle for Viewport Door (Screw/knob)
U	102153	Door Gasket: Each 1/16th inch (2 required)
V	11241	Air Divider for 155 Inside Cabinet
	101223	Cleaning Rod for Hoe Blade (6')
	102362	Hoe for Cleaning Rod
	101277	DECAL: "Horizon"
	102154	Insulation for Stack Cap
	11300	155 Heat Exchanger and Cabinet-Alumz
Q	11431	CAB: Burner End for 155
	11114	Snap Disc manual reset
	57459	Blower Wheel Only

BLUE CABINET MODEL 200

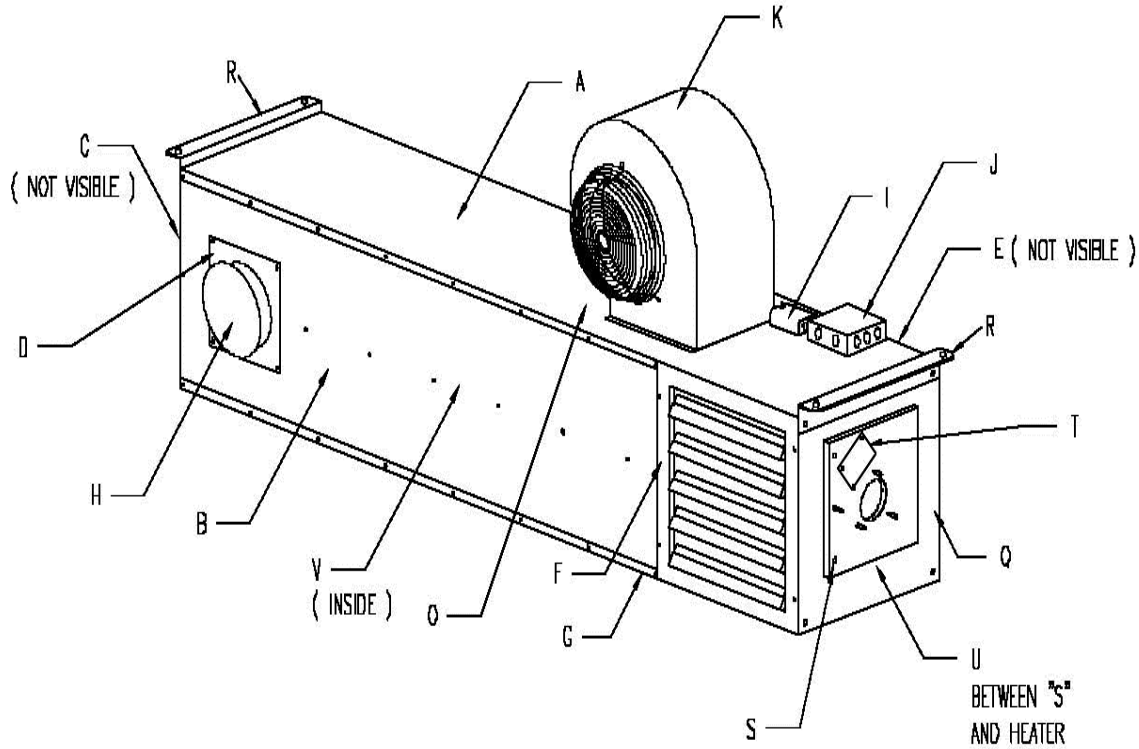

BURNER AND CORD OMITTED FOR CLARITY

Key	Part Number	Description
A	11440	CAB: Mdl 200 Top
B	11439	CAB: Mdl 200 L or R Side
C	11430	CAB: Stack End, Mdl 200
D	100501	CAB: Stack Outlet Cover Donut
E	11437	CAB: Blank Filler Panel for 200
F	12309	CAB: Louver Panel Kit for 200
G	11442	CAB: Base for 200
	102358	Louver w/bolts for 200/Each
H	102359	Stack Cap for all
	11457	AIR DEFLECTOR "U" SHAPE
	56803	PAINT: SPRAY 12OZ BLUE REFLEX
I	56419	SWITCH: FAN 5 IN UOF

J	56955	Junction Box (6"x6")
	57266	STRIP: TERMINAL 8 POLE 30 AMP
	57407	MOTOR: Blower Motor asm w/cap
K	11101	Blwer Wheel & Housing for 155 & 200
O	101140	Blower Guard for All /Each
	11103	Blower Housing Leg-LEFT for 155 & 200
	11104	Blower Housing Leg-RIGHT for 155 & 200
	11107	Rubber Bushing for leg / Each
	56421	Capacitor for motor , 15uf
	13142700	Mount for capacitor
Q	11431	CAB; Burner End for 200
R	102200	Mounting Brackets; Each 155 & 200 (2 required)
S	102365	Burner Door All w/ internal Viewtube
T		No longer available
	11932	Cab: Painted Skin for Burner Door
	11124	Handle for Viewport (Screw/Knob)
U	102153	Door Gasket: Each 1/16th inch (2 required)
V	11456	Air Divider for 200 Inside Cabinet 2 reqd
	101224	Clean Rod 5 ft: w/o Hoe Blade
	102362	Hoe for Cleaning Rod
	101277	DECAL: "Horizon"
	102154	Insulation for Stack Cap
	11400	200 Heat Exchanger and Cabinet-Alumz
	57459	Blower Wheel Only
	11114	Snap Disc manual reset

BLUE CABINET MODEL 245

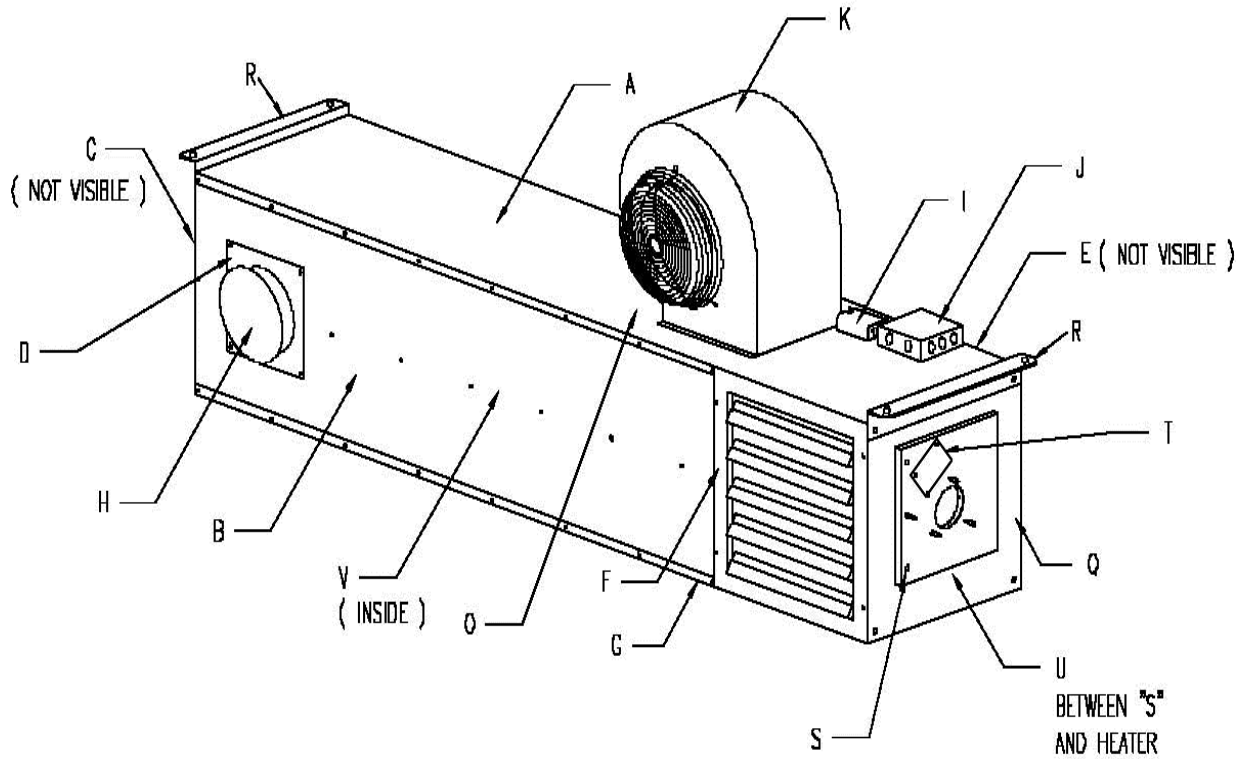

BURNER AND CORD OMITTED FOR CLARITY

Key	Part Number	Description
A	11740	CAB: Mdl 245 Top
B	11739	CAB: Mdl 245 L or R Side
C	11930	CAB: Stack End, Mdl 245
D	102353	CAB: Stack Opening Cover
E	11937	CAB: Blank Filler Panel for 245
F	100837	CAB: Louver Panel Kit for 245
G	11742	CAB: Base for 245
	56736	Louver wbolts for 245
H	102359	Stack Cap for all less insul.
	102154	Insulation for inside Stack Cap
	100506	AIR DEFLECTOR "U" SHAPE

I	56419	SWITCH: FAN 5 IN UOF
J	56955	Junction Box (6"x6")
	57266	STRIP: TERMINAL 8 POLE 30 AMP
	57406	MOTOR: Blower motor w/cap
K	11102	Blower Wheel & Housing for 245
O	101140	Blower Guard for All / Each
	11105	Blower Housing Leg-LEFT for 245
	11106	Blower Housing Leg-RIGHT for 245
	11107	Rubber Bushing for leg/Each
	55774	Motor Capacitor
	103534	STRAP: CAPACITOR BRACKET
	101300	1 H/P Motor Only for Blower
Q	11931	CAB: Burner End for 245
R	100200	Mounting Brackets/Each 245 (2 required)
S	102365	Burner Door all w/ internal Viewtube
T		OBSOLETE
	11932	Painted Skin for Burner Door
	11124	Handle for Viewport Door (Screw/knob)
U	102153	Door Gasket: Each 1/16th inch (2 required)
V	11741	Air Divider for 245 Inside Cabinet 2 reqd
	101223	Cleaning Rod for Hoe Blade(6')
	102362	Hoe for Cleaning Rod
	101277	DECAL" "Horizon"
	102154	Insulation for Stack Cap
	12107	245 heat Exchanger and Cabinet-Alumz
	11114	Snap Disc manual reset
	101231	Blwr Wheel & Housing w/ feet only

BLUE CABINET MODEL 315

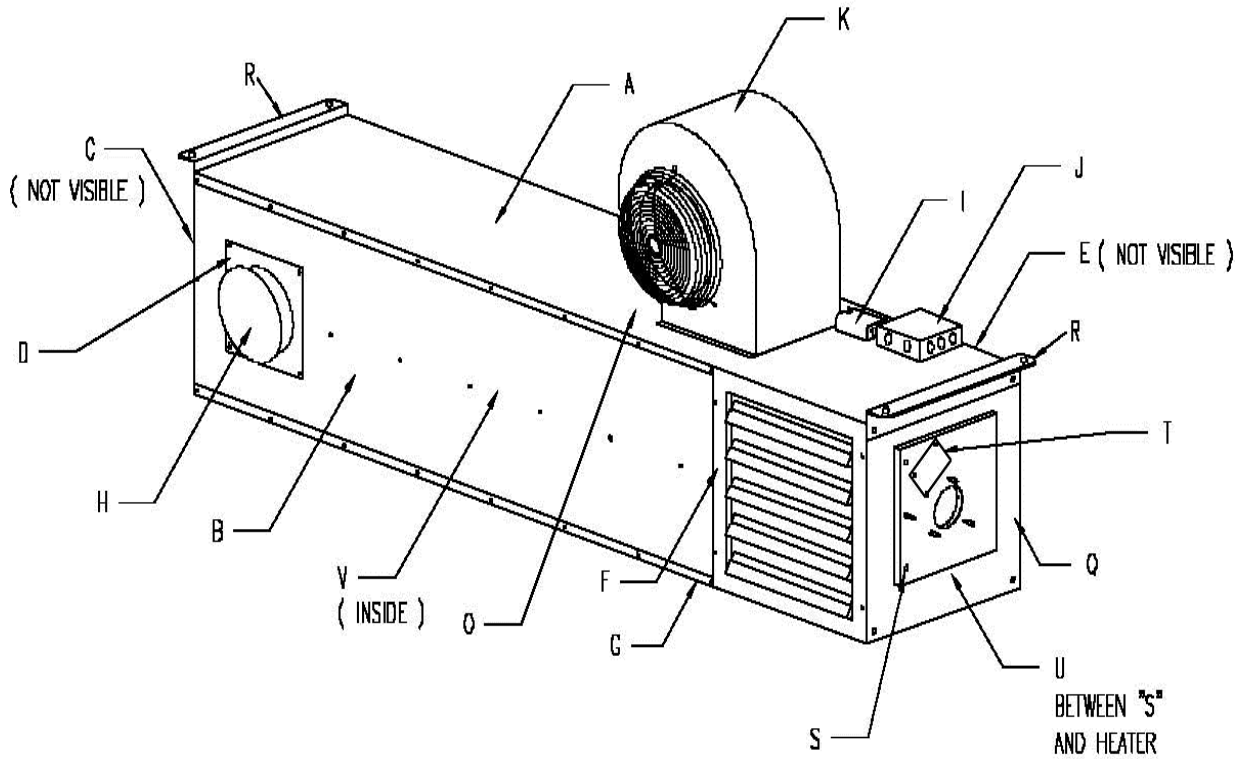

BURNER AND CORD OMITTED FOR CLARITY

Key	Part Number	Description
A	11940	CAB: Mdl 315 Top
B	11939	CAB: Mdl 315 L or R Side
C	11930	CAB: Stack End, Mdl 315
D	102353	CAB: Stack Outlet Cover Donut
E	11937	CAB: Blank Filler Panel for 315
F	100837	CAB: Louver Panel Kit for 315
G	11942	CAB: Base for 315
	56736	LOUVER W/BOLTS: REQS. 5 PER HTR
H	102359	Stack Cap
	56803	PAINT: SPRAY 12OZ BLUE REFLEX

I	56419	SWITCH: FAN 5 IN UOF
J	56955	Junction Box (6"x6")
	57266	STRIP: TERMINAL 8 POLE 30 AMP
	57406	MOTOR: Blower motor w/cap
K	11102	Blower Wheel & Housing for 315
O	101140	Blower Guard for All / Each
	11105	Blower Housing Leg-LEFT for 315
	11106	Blower Housing Leg-RIGHT for 315
	11107	Rubber Bushing for leg/Each
	55774	Motor Capacitor
	103534	STRAP: CAPACITOR BRACKET
	101300	1 H/P Motor Only for Blower
Q	11931	CAB: Burner End for 315
R	100200	Mounting Brackets/Each 315 (2 required)
S	102365	Burner Door all w/ internal Viewtube
T	100506	AIR DEFLECTOR "U" SHAPE
	11932	Painted Skin for Burner Door
	11124	Handle for Viewport Door, Screw/Knob
U	102153	Door Gasket: Each 1/16th inch (2 required)
V	100505	Air Divider for 315 Inside Cabinet 2 reqd
	101223	Cleaning Rod for Hoe Blade(6')
	102362	Hoe for Cleaning Rod
	101277	DECAL" "Horizon"
	102154	Insulation for Stack Cap
	11901	315 heat Exchanger and Cabinet-Alumz
	101231	Blwr Wheel & Housing w/ feet only

BLUE CABINET MODEL 235

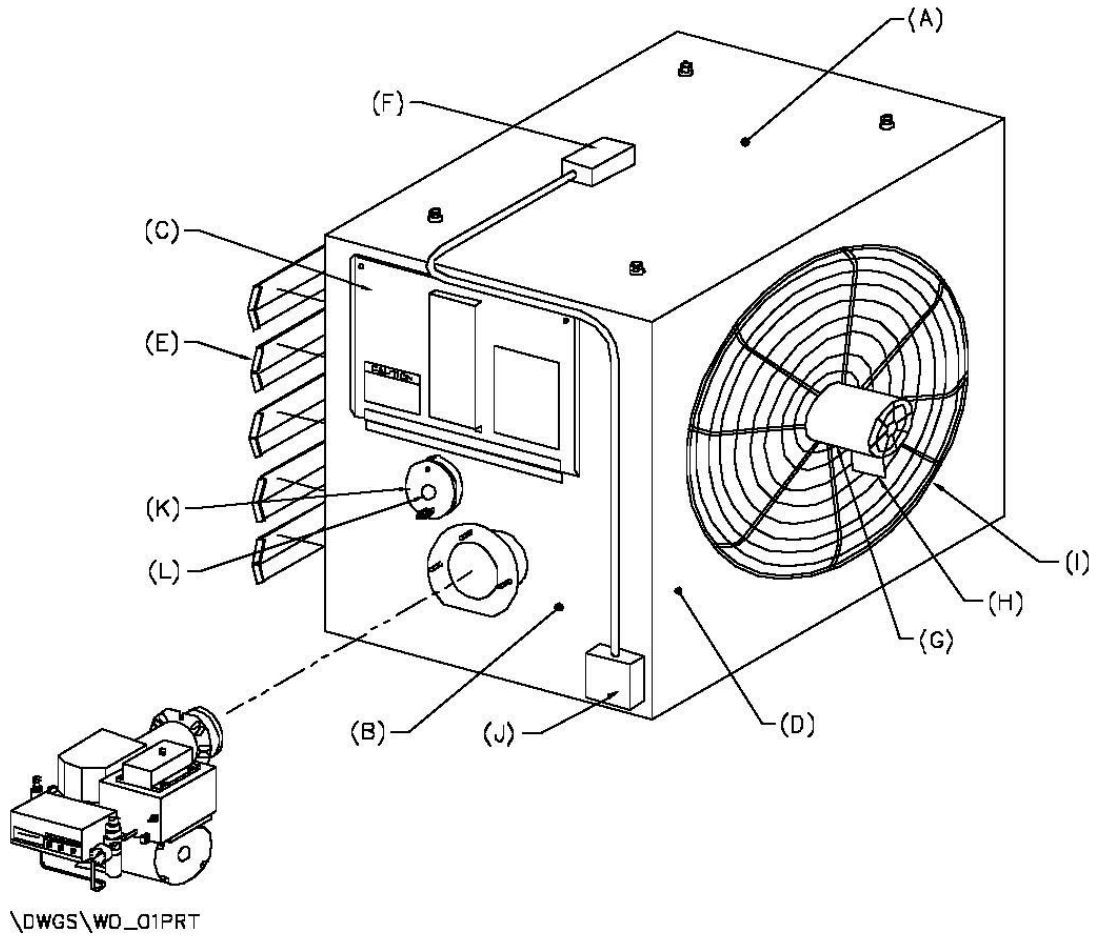

Cabinet, Heat Exchanger for WO-F235 3-pass (Previously Model WO-F200)

Key	Item #	Item	Description
Cabinet and Fan			
A	56451	CAB: TOP F/235	Cabinet, Top
B	56452	CAB: BRNR End F/235	Cabinet, Burner End
C	56443	CAB: Clean-out Door 175/235	Cabinet, Clean out Door
	56454	CAB: Door w handle F/175/235	Cabinet, Door with Handle (exhaust side)
D	56455	CAB: Fan Side 235	Cabinet, Fan Side
	56456	CAB: LVR Side Upper PNL 235	Cabinet, Louver Side – Upper Panel
	56457	CAB: LVR Side –Side PNL	Cabinet, Louver Side - Side Panel
	56458	CAB: LVR Side LWR PNL 235 PNTD	Cabinet, Louver Side – Lower Side
E	56846	LVR: w/ bolts 235/350	Louver with Bolts, Each (5 louvers required)
F	56419	Switch: Fan 5” UOF	5” Fan Switch (for top mounted switches)
	56420	Switch: 8”	8” Fan Switch (only for switches mounted next to burner)
G	56427	Motor: Fan ½ HP	½ HP Fan Motor Only, 1075 RPM
	56994	Fan Motor ASM: ½ HP	1/2HP Fan Motor Assembly (includes fan motor, capacitor, electrical box and wiring)
	57451	Strap: Fan MTR Capacitor MT	Fan Motor Capacitor Mount Kit
H	56426	Capacitor: Motor, 1 Ouf 6x656	Capacitor for ½ HP Fan Motor
	56430	Blade: Fan 175/235 14D ½ Bore	Fan Blade
I	56432	Guard: Fan	Fan Guard
	56433	Clamp: Fan Guard w/Screws (6)	Clamps for Fan Guard with Screws (set fo 6)
J	56955	Junction Box: WL60 & UOF	Junction Box
	56958	CVR: JCN Box Fan S/W UOF	Cover for Junction Box
	57266	Strip: Terminal 8 Pole 30 AMP	8 Pole Terminal Strip
Heat Exchanger			
	56678	Heat EX CAB: 235 L/BRNR & ACC	Heat Exchanger Aluminized with Cabinet, less Burner and Accessories
	56669	Heat EX L/CAB: 235 L/BRNR, ACC	Heat Exchanger Aluminized, less Cabinet, less Burner and Accessories
	56950	CLNOUT DR: HT EX 175/235	Clean-Out Door for heat Exchanger
K	57267	Sight Plate: New Style 175++	Sight Plate
	57270	Spring: Compression Music Wire	Compression Spring for Sight Glass Door
	56819	Sight Plate Retrofit Kit	Conversion Kit for sight Plate Assembly
L	57269	Glass: Sight	Sight Glass
	57279	DR: w/Outlet Collar 175/235	Door with Outlet Collar for Bolt in Baffle
	57272	Baffle: Bolt In	Stainless Steel Bolt in Baffle
	57276	Smoke Outlet W/SS Baffle	Door with Smoke Outlet Plate and Stainless Steel Baffle
	56824	Target Shield: SS +Nut 175/235	Stainless Steel Target Shield with Lock Nuts
	56965	Baffle: SS Repl W/GSKT RETNRS	Stainless Steel Replacement Baffle
	56608	Target: 175/235 Ceramic w/Bolts	Target Shield
	54756	Reinforcement Plate: Per pair	Reinforcement Plate
	56917	Rope: Fiberglass Braid 5/8”	5/8” Fiberglass Rope Gasket – per foot (14’ per unit required)

BLUE CABINET MODEL 350

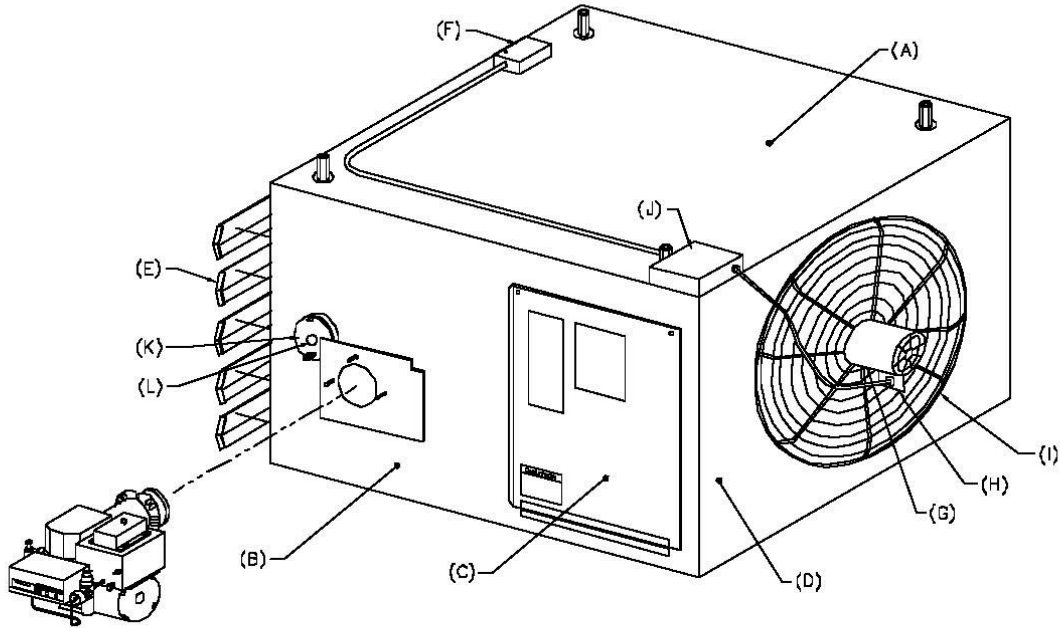

\\DWGS\WC_04.d

Key	Part Number	Description
A	56461	CAB: TOP
	8911	OPENING COVER FOR SUSPENSION LUGS
B	56462	CAB: BURNER SIDE
	11170	CAB: BASE SKIN
C	8887	CAB: DOOR PANEL
D	6882	CAB: FAN SIDE
E	6846	LOUVER: REQ. 5 PER HEATER
	6883	CAB: LOUVER SIDE UPPER PANEL
	6884	CAB: LOUVER SIDE LOWER PANEL
	100054	CAB: VERT. LOUVER PANEL (BURNER SIDE)
	6885	CAB: VERT. LOUVER PANEL (STACK SIDE)
	8782, 8783	CAB: VIEW/BRNR HOLE COVER, ORDER 1 EA.

	6775	CAB: STACK SIDE W/ 8" STACK HOLE
G	57453	Fan Motor only, no capacitor etc
	56993	Fan Mtr Asm: w/ capacitor, elect box, etc
	13142700	MT: CAPACITOR
H	56421	Capacitor 15 ufd
	56435	BLADE: FAN 350 30DEG 1/2BORE
	56437	COLLAR: SHAFT WRAP GRIP
I	56432	GUARD: FAN
J	56955	Junction Box (6"x6")
	56958	CVR: JCN BOX FAN - UOF
	57266	STRIP: TERMINAL 8 POLE 30 AMP
Heat Exchanger		
	56836	HEAT EX CAB: 350 L/ BRNR & ACC
F	56420	SWITCH: FAN 8 IN
	55778	Tube 3.5od, used Ht Exch, HRPO 19 reqd
K	57267	Sight Plate: New Style
	57270	Spring Handle for viewport
L	57269	GLASS: SIGHT
	58869	Hinged Burner Mt w/ rod, removable
	57274	SMOKE OUTLET PL A/W A: 350/98
	56966	REPAIR BAFFLE
	96872	TARGET: 350/500 Stainless Steel w/bolts
	56961	REINFORCEMENT PLATE:PER PAIR
	58360	Stainless Steel Tube Insert
	56917	ROPE: FbrGlass 5/8 (180" needed)

BLUE CABINET MODEL 500

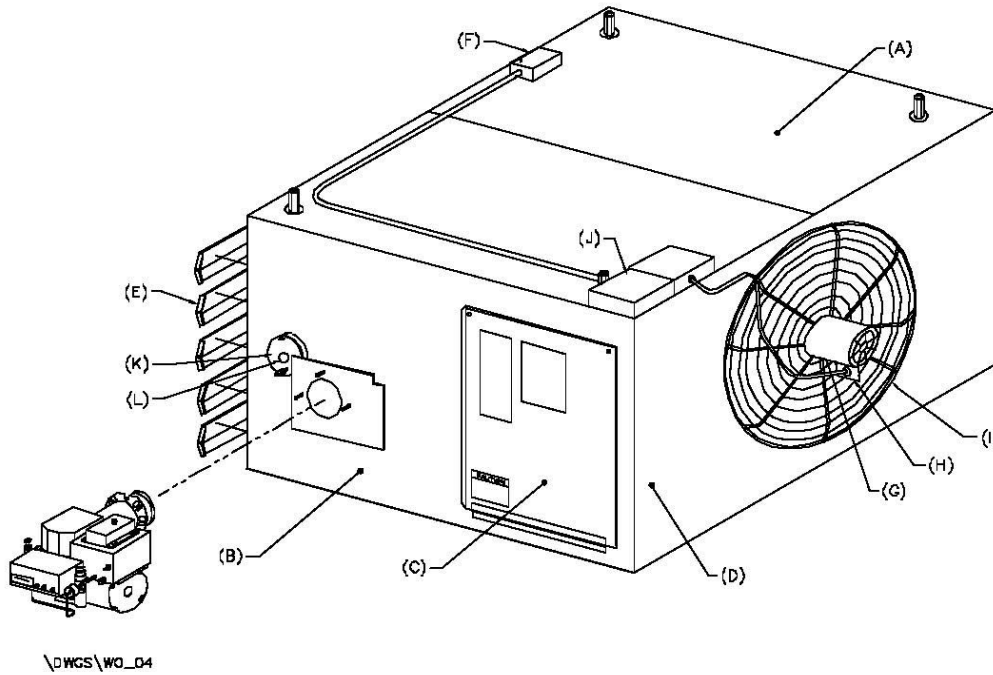

Key	Part Number	Description
	8889	CAB: TOP F500 BURNER SIDE
A	8890	CAB: TOP F500 STACK SIDE
	11175	CAB: BASE SKIN
B	8886	CAB: BURNER SIDE
C	8887	CAB: DOOR PANEL
	100054	CAB: VERT. LOUVER PANEL (BURNER SIDE)
	6885	CAB: VERT. LOUVER PANEL (STACK SIDE)
	8726	CAB: STACK SIDE, 10" OPENING W/ HANDLE
D	8888	CAB: FAN SIDE
	8782, 8783	CAB: VIEW/BRNR HOLE COVER, ORDER 1 EA.

	8891	CAB: LOUVER SIDE UPPER PANEL
	8895	CAB: LOUVER SIDE LOWER PANEL
	8911	CAB: DONUT COVER HANGING NUT
E	8962	LOUVER w/o bolts: 5 louvers/heater
F	56420	SWITCH: FAN 8 IN
G	55770	Motor only 1 Hp for fan (no capacitor etc)
	58832	Electrical Box for mounting to Fan Mtr
	58833	Lid for Elect Box on Fan Mtr
	56605	Fan Motor Asm, w/ capacitor etc
H	55774	CAPACITOR: MOTOR, 20uf 6X660
	55776	BLADE: FAN 500 40 DEG 24 IN
	56437	COLLAR: SHAFT WRAP GRIP
I	56432	GUARD: FAN
J	56955	Junction Box (6"x6")
	56958	CVR: JCN BOX FAN - UOF
	57266	STRIP: TERMINAL 8 POLE 30 AMP
	56951	FAN RELAY BOX UOF500UL
	56954	RELAY: FAN DPST NO 6 SPADE

Heat Exchanger		
	56856	HT EXCH W/ CAB. L/ACC , L/ BURNER
	86789	Tube Cover a/w asm w/ mt plates
K	57267	Sight Plate: New Style
	57270	Spring Handle for viewport
L	57269	GLASS: SIGHT
	58869	Hinged Burner Mt w/ rod, removable
	57277	SMOKE OUTLET A/W ASM: 500UL
	96872	TARGET: FOR MDL 350/500 Stainless Steel w/bolts
	56966	BAFFLE: SS, PREVENTS FLUE GAS TO STACK
	86790	Clean out door a/w asm
	56917	ROPE: FbrGlass 5/8 (180" needed)
	58360	Stainless Steel Tube Insert
	55778	Tube 3.5od, used Ht Exch, HRPO 19 reqd

ACCESSORIES FOR BLUE HEATERS

Key	Part Number	Description
	56400	SCREEN: SUCTION 3/4MPT, 2.6"OD, 3.6"LG
	56401	SCREEN ALT:SUCT 3.4"OD,8"LG,100MESH,1.5FPT
	56405	VALVE: CHECK, BRASS 3/4 FPTx3/4FPT
	100171	FILTER SS CLEANABLE (HEAD,BODY,ELEMENT)
	56410	FILTER ASM COMPLETE: INCL 56409,56411
	56409	BASE: USE W/ 56411 SPIN ON FILTER ELEMENT
	56411	FILTER ELEMENT (SPIN ON): USE W/ 56409
	57155	FILTER SS, 100171 W/ GAUGE
	57151	REPL. FILTER ELEMENT W/ ORING: FOR 100171
	57153	ORING ONLY: FOR ELEMENT IN 100171
	57158	FILTER: AIR IN-LINE 1/4 NPT
	15711	VALVE: BALL 1/2 NPT X 1/2 NPT
	57263	VALVE: BALL 1/2FNPT X 3/8FLARE
	56680	SWIVEL 1/2 MPT X 1/4 FPT UOF
	56681	SWIVEL: 3/4 MPT X 1/2 FPT UOF
	56683	TEE: BLACK 1/4 X 1/4 X 1/8
	56685	NIPPLE: HEX 1/4 NPT X 1/4 NPT
	56686	NIPPLE: HEX 1/2 NPT X 2 IN
	56688	NIPPLE: GALV 1/4 X 2
	57144	GAUGE: AIR/VACUUM 60 PSI
	56418	THERMOSTAT: WALL LOW VOLTAGE
	57218	RACK CLIP: TANK STAND UOF 500-
	56663	BUSHING: DBL TAP 2MPT X 3/4FPT

PUMP PARTS ALL MODELS

Key	Part Number	Description
A-Pump		
	55842	PUMP: MDL A, LIP, PUMP ONLY
	55712	MOTOR: OIL TRANS PUMP BASE MOU
	55715	COUPLING: F/TRANS PUMP
	56927	GASKET: FLAT, A PUMP COVER
	57264	SCREEN: FILTER STRAINER A-PUMP
	55892	ADAPTER: STEEL 1/4FPTX1/8MPT
J-Pump		
	56934	PUMP: MDL J, FACE, PUMP ONLY
	57201	MOTOR: BRNR 1/4 HP 1725 RPM
	57261	COUPLING: OIL TRANSFER PUMP
	56923	GASKET: FLAT, J PUMP COVER
	57265	SCREEN: FILTER STRAINER J PUMP
	55892	ADAPTER: STEEL 1/4FPTX1/8MPT

BURNERS

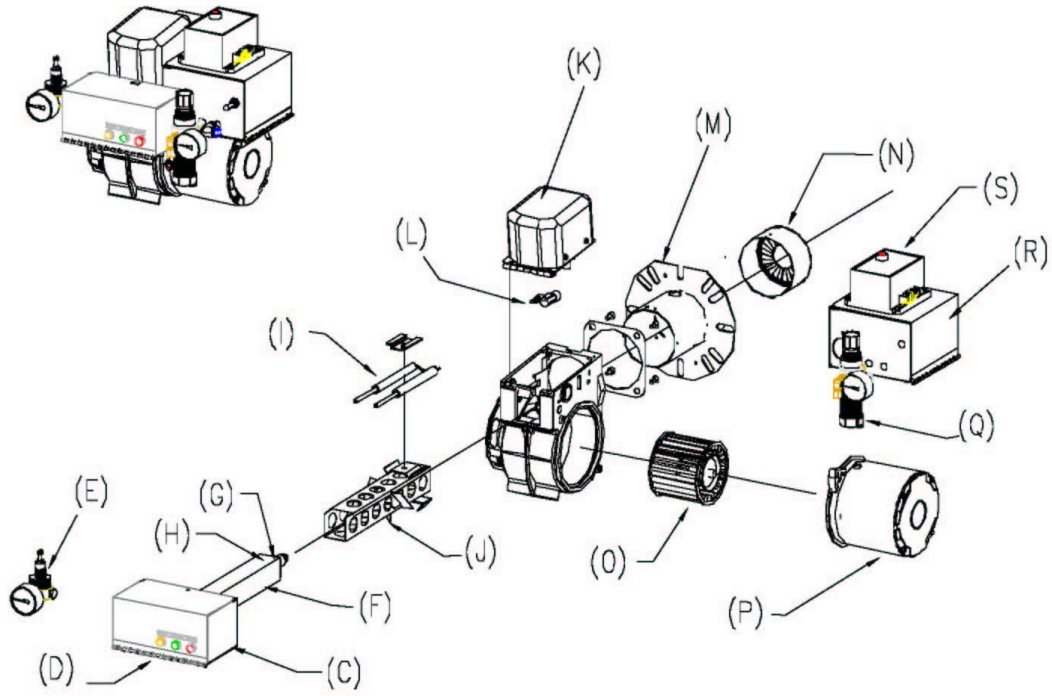

WOB5ALL.CGM

Key	Part Number	Description
Slide Gun Assemblies		
B	56899	Slide Gun Assy. For Models up to 155
	56904	Slide Gun Assy. For Model 175
	56905	Slide Gun Assy. Models 235 & Mdl s 200, 245, 315
	56908	Slide Gun Assy. For Model 350
	56914	Slide Gun Assy. For Model 500
C	56906	OIL CTRL BOX: PAINTED
	57118	STRIP: TERMINAL 6 POLE 20A BLK
D	57120	LIGHT: CTRL RED 120V
	57121	LIGHT: CTRL AMBER 120V
	57122	LIGHT: CTRL GREEN 120V
E	57130	REGULATOR: OIL W/ GAUGE
	57129	REGULATOR: OIL W/SET SCREW
	57144	GAUGE: AIR/VACUUM 60 PSI
	57197	SCREW: HEX WSHR TEK UNSL
	57198	BUSHING: BRASS 1/8 F X 1/4 M
	57127	DIAPHRAGM:
	101050	Thumb 10/24 x 1/2 screw
	57128	SEAT: OIL REGLTR FLOW-REGULAR
	57111	GASKET: REGULATOR SEAT
	57190	SOLENOID: OIL/AIR 115V/60HZ
F	57175	P-HEAT BLOCK: W/PLUG 57 ALUM
	101084	PLUG: SQUARE HEAD, W/VIBRASEAL
	101261	INSERT BIT: 7/16 X 3/16 ML SQ
	57195	TUBE: COPPER 1/4 OD UOB
	57196	NIPPLE: GALV 1/8 X 3-1/2 STD
	57206	FTG: 1/8 NPT X 1/4 COMP W/N&F
G	57103	Nozzle up to Model 155 (9-1)
	57107	Nozzle Model 175 (7-3)
	57105	Nozzle ,Model 200 to 315 (9-5)
	57106	Nozzle ,Model 350 (7-2)
	57108	Nozzle ,Model 500 (9-11)
	57177	NOZZLE RETAINER PLATE: W/SCRW
H	57181	SCREW: SOCKET 8-32 X 1/2

BURNERS CONTINUED

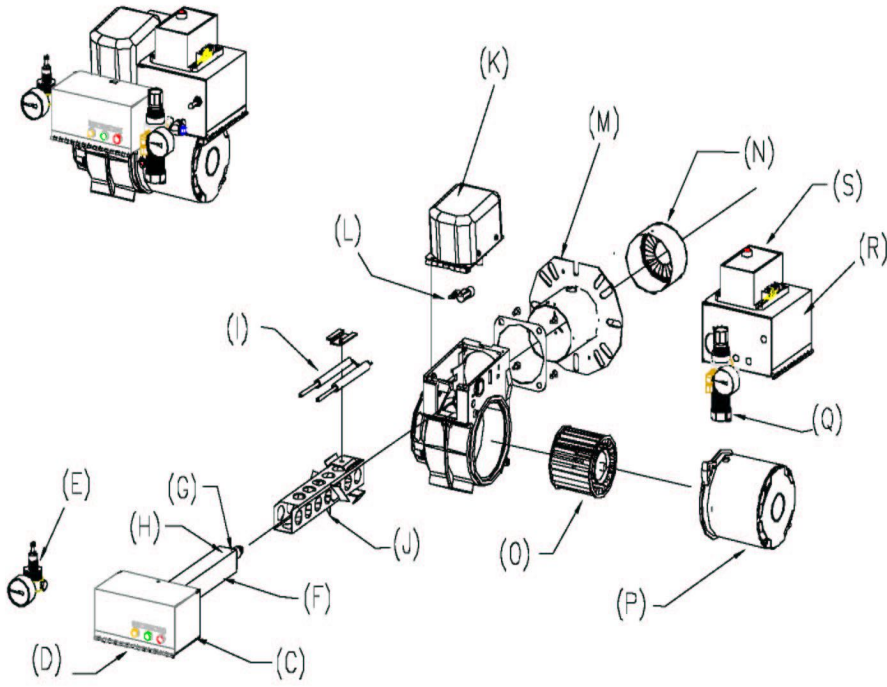

WOB5ALL.CGM

Key	Part Number	Description
Slide Gun Assemblies (continued)		
	57179	NOZZLE ADAPTOR: W/O-RING WOF
	57186	O-RING: F/ DELAVAN NOZZLE
	57182	O-RING: NOZZLE ADAPTOR 3/4 OD
	57184	O-RING: NOZZLE GLAND, 5/16 OD
	57146	SENSOR: TEMPERATURE 140 +/-8
	57149	SENSOR: TEMPERATURE 160 DEG
	57160	ELEMENT: HTR CART 130W 120V
	57165	ELEMENT: HTR CART 300W 1/4X905
	57172	PLUG: MALE ISO/GRND
I	57110	ELECTRODE: SET OF TWO
	56921	CLAMP: ELECTRODE SLIDE GUN
J	56920	SLEEVE SPPT ASM: NS W/FINS
Burner Housing		
	57189	HSG: BRNR ASM W/ NOTCH
K	57222	TRANSFORMER: WEBSTER 2 BUSSBAR
	56991	BUSS BAR: TRNSFMR W/EXT&SCRW
	56989	BAR: (SET OF 2) BUSS BNR WOF TRNSFR
L	57209	CELL: CADMIUM 60 IN LEADS
M	57205	AIR TUBE W/FLANGE: DRILLED UOF
N	57116	RETENTION HEAD: 45 DEG SS B5
O	57204	BLWR WHEEL: UOB125M - UOB500M
P1	57200	MOTOR: BRNR 1/7HP NOT FOR AIR PUMP
	56974	AIR RESTRICTOR PLATE: W/BOLTS
	10558530	1/2" Knock Out Seal for Burner Housing
	52321	SHUTTER: AIR F/ BURNER
	56377	BAND: AIR BECKETT BRNR
	10850270	LABEL: "Hot"
	57280	GROMMET: RBR5/8IDX1-1/8ODX5/16
Air Pump (K5 Burners)		
	11235	
	111826	Needle Valve (Pressure Adj. K5 burners)
	11236	Inlet Air Filter for K5 burners
	32340	Coupler (Motor to Air Pump, K5 Burner)
P2	57203	Motor: K5 burner (drives fan & air pump)
Air Control Box		
Q	57140	REGULATOR: AIR W/ GAUGE
	57156	REGULATOR: AIR FILTER L/GAUGE
	57143	BOWL: AIR REGULATOR ASM
	57157	ELEMENT: FILTER WHITE STONE
	56967	AIR PRESSURE TANK
	57144	GAUGE: AIR/VACUUM 60 PSI

BURNERS CONTINUED

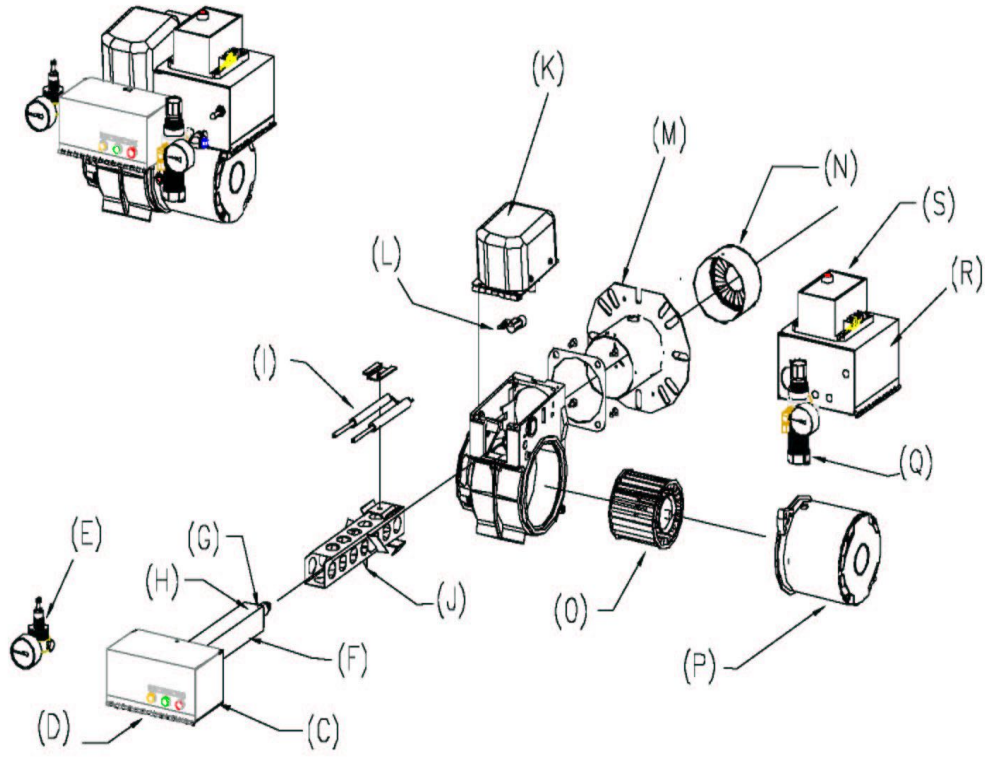

WOB5ALL.CGM

Key	Part Number	Description
Slide Gun Assemblies (continued)		
	57173	PLUG: FEMALE ISO/GRND
R	56913	AIR CTRL BOX: PAINTED 235
	100333	AIR CTRL BOX: ASM UOF500UL
	56932	BRKT: SPPT UOF AIR CTRL BOX
	57280	GROMMET: RBR5/8IDX1-1/8ODX5/16
	56967	AIR PRESSURE TANK: NS PAINTED
	57199	NIPPLE: BRASS NPT MALE HEX 1/8
	57119	STRIP: TERMINAL 8 POLE 20 AMP
	57193	ADAPTER: SWIVEL MALE 1/8 NPT
	57214	METER: HOUR W/2 LEADS
	57215	BRKT: HOBBS HR METER UOB
	57235	QUICK DISCONNECT:CORD-MALE
	57240	DISCONNECT ASM: QUICK CORD FEM
S	57207	CTRL ASM: PRIMARY W/BUTT SPLC
	57190	SOLENOID: OIL/AIR 115V/60HZ
	57194	O-RING: SOLENOID BOTTOM
	57252	KIT: CNVRT SNTEC>COMBU AIR SOL
	57169	TOGGLE SWITCH: OIL PRIME
	57180	AIR PROVING SWITCH, UNIVERSAL
	57174	AIR LINE ALUMINUM FOR NON AIR PUMP BRNR
	57211	ELL: 1/8 NPT X 1/4 COMP
	57192	PLUNGER: ZINC, W/ SPRG & SPCR
	57139	PLUNGER: NICKEL, W/SPRG & SPCR
	57212	ELBOW: BRAS STREET 1/8 NPT
	57213	ELL: GALV ST 90 DEG 1/8
	42209200	TIMER/RELAY: INFITEC 500UL BRN
	57185	SOLENOID: OIL/AIR COMBU W/ORIF

Ductable parts for WOH-350

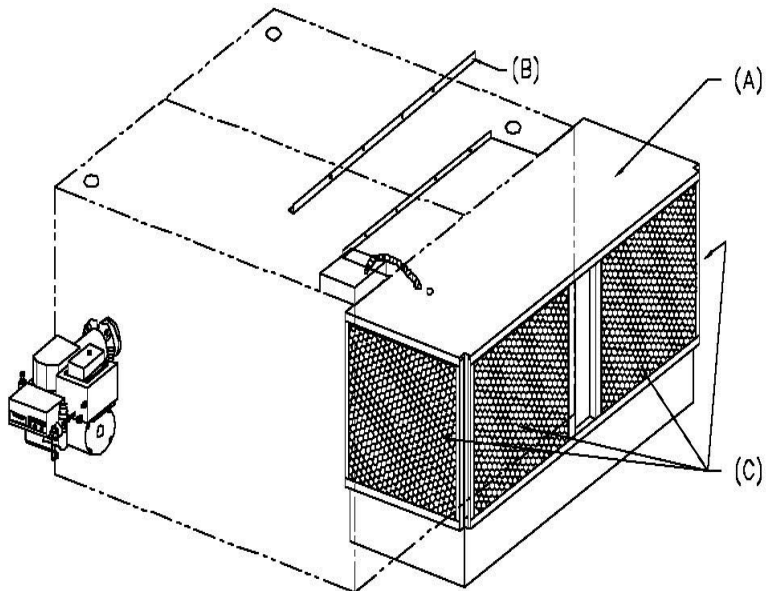

\\DWGS\WO_03PRT

Key	Part Number	Description
A	86744	BLWR CABINET A/W ASM ONLY 35D
	56746	CAB: BLOWER SIDE (REPLACES ROUND OPNG)
B	54792	ADAPTER ANGLE: 350 & 500
	54791	CONNECTOR: DUCT UOF-D
C	57400	FILTER: AIR ALUM
	57450	BLWR/MTR: KIT UOF350D 3/4 HP DIRECT DRIVE (2 REQUIRED) 115V/60HZ
	57449	BLWR/MTR: KIT UOF350D/220-3/4H DIRECRT DRIVE (2 REQUIRED) 220V/60HZ
	57453	MOTOR: BLWR 115V/60, 3/4 3M300
	57454	MOTOR: BLWR 220V/60, 3/4 3M222
	57458	BLWR: 3/4 HP 115/220 MTR
	57459	WHEEL: BLOWER B 3/4 HP
	57451	STRAP: FAN MTR CAPACITOR MT
	38869	RELAY: DPST 120V
	56118	STRIP: TERMINAL 6 POLE 20A WHT
	57452	CAPACITOR 7.5 UF 370V 50/60
	56421	CAPACITOR 15 UF 440V 50/60

Ductable parts for WOH-500

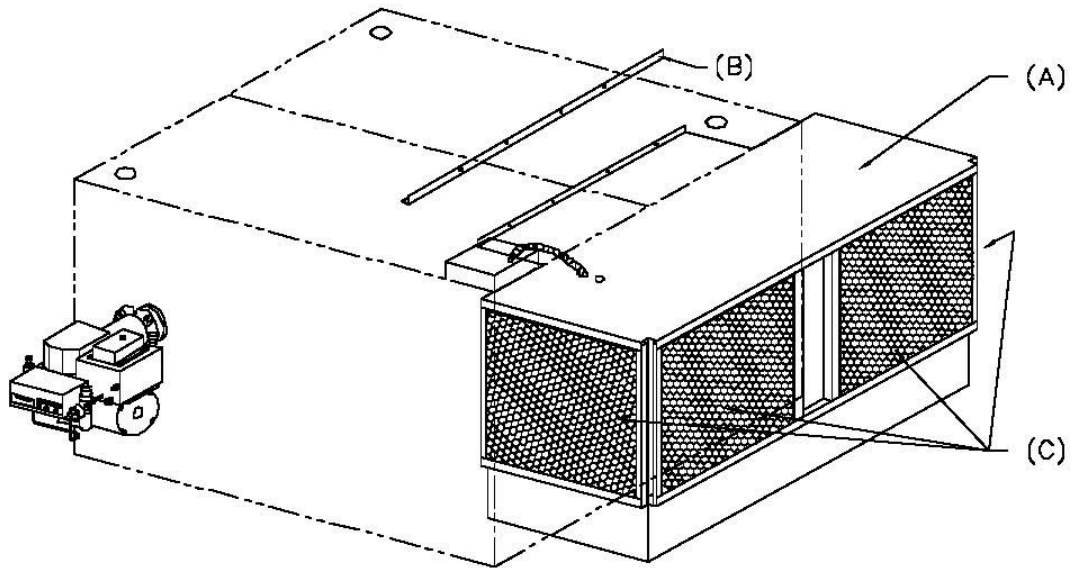

\\DWGS\WG_03PRT

Key	Part Number	Description
A	56762	BLWR CAB ASM ONLY: 500D RP
	56749	CAB: BLOWER SIDE (REPLACES ROUND OPNG)
B	54792	ADAPTER ANGLE: 350 & 500
	54791	CONNECTOR: DUCT UOF-D
C	57400	FILTER: AIR ALUM
	55787	BLWR/MTR: UOF500D 1HP/220V/60H
	55789	MOTOR: BLWR 1HP/220V/60HZ
	57405	BLWR: 175D-235D-500D (2C975)
	38869	RELAY: DPST 120V
	56118	STRIP: TERMINAL 6 POLE 20A WHT
	43015600	BELT: BLWR KIT (4L480)
1"	43015620	PULLEY: BLOWER KT
5/8"	43015610	PULLEY: BLOWER KT

WARRANTY

USED-OIL FIRED HEATER SYSTEMS (NOT BOILERS)

Firelake Mfg., LLC ("FIRELAKE") warrants each new SHENANDOAH® Used Oil-Fired product manufactured by it to be free from defects in material or workmanship for one (1) year from and after the date of initial installation by or for the original purchaser. If such a defect is found by the Manufacturer to exist within the one (1) year period, the Manufacturer will, at its option, (a) repair or replace such product free of charge, [F.O.B.] the factory of manufacture, or (b) refund to the original purchaser the original purchase price, in lieu of such repair or replacement. Labor costs associated with the removal, replacement, repair and/or reinstallation of the product are not covered by the Manufacturer. Notwithstanding the preceding paragraph, Heat Exchanger Firebox components of SHENANDOAH® Used Oil-Fired Heaters and Furnaces shall be subject to the prorated extended warranty period set forth below.

CONDITIONS AND LIMITATIONS

1. The product must be installed by and operated in accordance with the instructions published by the Manufacturer or Warranty will be void.
2. Warranty is void if all components of the system are not original equipment [supplied] [manufactured] by the Manufacturer.
3. This product must be purchased from and installed by an authorized dealer or certified representative thereof or the Warranty will be void.
4. Malfunctions or failure resulting from misuse, abuse, negligence, alteration, accident, or lack of proper maintenance shall not be considered defects under the Warranty.
5. Use of solvents or other highly flammable fluids, such as, but not limited to, benzene, methylethyl, ketones, toluene, xylene or naphtha with Used Oil-Fired products, shall void this Warranty.
6. Modification of products by a distributor, dealer or end-user shall void this Warranty, unless specifically authorized in writing by the Manufacturer. Use of parts for modification or repair of a product or any component thereof which is not authorized by or manufactured by FIRELAKE shall void this Warranty.

LIMITED WARRANTY PERIOD FOR 3-PASS HEAT EXCHANGER FIREBOXES:

The Warranty Period for Aluminized Heat Exchanger Fireboxes for Used Oil-Fired Heaters and Furnaces shall be ten (10) years from the date of from and after the date of initial installation by or for the original purchaser OR 20,000 hours, whichever occurs first, and shall be subject to the prorated table listed below:

0 to 1 year or 2,000 hours	full replacement parts
1 to 2 years or 2,001 to 4,000 hours	full replacement parts
2 to 3 years or 4,001 to 6,000 hours	full replacement parts
3 to 4 years or 6,001 to 8,000 hours	purchaser pays 40% of list price
4 to 5 years or 8,001 to 10,000 hours	purchaser pays 50% of list price
5 to 6 years or 10,001 to 12,000 hours	purchaser pays 60% of list price
6 to 7 years or 12,001 to 14,000 hours	purchaser pays 70% of list price
7 to 8 years or 14,001 to 16,000 hours	purchaser pays 75% of list price
8 to 9 years or 16,001 to 18,000 hours	purchaser pays 80% of list price
9 to 10 years or 18,001 to 20,000 hours	purchaser pays 90% of list price

On Line Registration: www.firelakemfg.com Click on "warranty"

LIMITED LIFETIME WARRANTY ON Single Pass™ HEAT EXCHANGER FIREBOXES:

The Limited Lifetime Warranty on Horizon™ shall be from the date of, from and after the date of initial installation by or for the original purchaser at a prorated schedule of years OR hours, whichever occurs first, and shall be subject to the prorated table listed below:

0 to 1 year or 2,000 hours	full replacement parts
1 to 2 years or 2,001 to 4,000 hours	full replacement parts
2 to 3 years or 4,001 to 6,000 hours	full replacement parts
3 to 4 years or 6,001 to 8,000 hours	purchaser pays 40% of list price
4 to 5 years or 8,001 to 10,000 hours	purchaser pays 50% of list price
5 to 6 years or 10,001 to 12,000 hours	purchaser pays 60% of list price
6 to 7 years or 12,001 to 14,000 hours	purchaser pays 70% of list price
7 to 8 years or 14,001 to 16,000 hours	purchaser pays 75% of list price
8 to 9 years or 16,001 to 18,000 hours	purchaser pays 80% of list price
9 to 10 years or 18,001 to 20,000 hours	purchaser pays 90% of list price
10+ years or 20,000+ hours	purchaser pays 90% of list price

All other conditions and limitations stated herein shall apply to the Warranty Period all heat exchangers.

The Manufacturer shall not be liable for any consequential or special damage which any purchaser may suffer or claim to suffer as a result of any defect in the product. "Consequential" or special damages" as used herein include, but are not limited to, lost or damaged products or goods, costs of transportation, lost sales, lost orders, lost income, increased overhead, labor and incidental costs and operational inefficiencies.

THIS WARRANTY CONSTITUTES THE MANUFACTURER'S ENTIRE AND SOLE WARRANTY AND THIS MANUFACTURER EXPRESSLY DISCLAIMS ANY AND ALL OTHER WARRANTIES, INCLUDING, BUT NOT LIMITED TO, EXPRESS AND IMPLIED WARRANTIES AS TO MERCHANTABILITY [Note that Shenandoah limited warranties of merchantability and fitness for particular purpose to 1 year – we should exclude], FITNESS FOR PARTICULAR PURPOSES SOLD AND DESCRIPTION OR QUALITY OF THE PRODUCT FURNISHED HEREUNDER.

FIRELAKE distributors and/or dealers are not authorized to modify or extend the terms and conditions of this Warranty in any manner or to offer or grant any other warranties for SHENANDOAH® products in addition to those terms expressly stated above.

An officer of Firelake Mfg., LLC must authorize any exceptions to this Warranty in writing. The Manufacturer reserves the right to change models and specifications at any time without notice or obligation to improve previous models. Effective October 1, 2004

The employees of FIRELAKE MFG., LLC would like to thank your for your recent SHENANDOAH® purchase. If a problem should arise, your SHENANDOAH® dealer can supply the necessary information to help you.

On Line Registration: www.firelakemfg.com Click on "warranty"