

CLICK ANYWHERE on THIS PAGE to RETURN to FER Ferroli HEATING SYSTEM AGE MANUALS & CONTACT INFO at InspectApedia.com

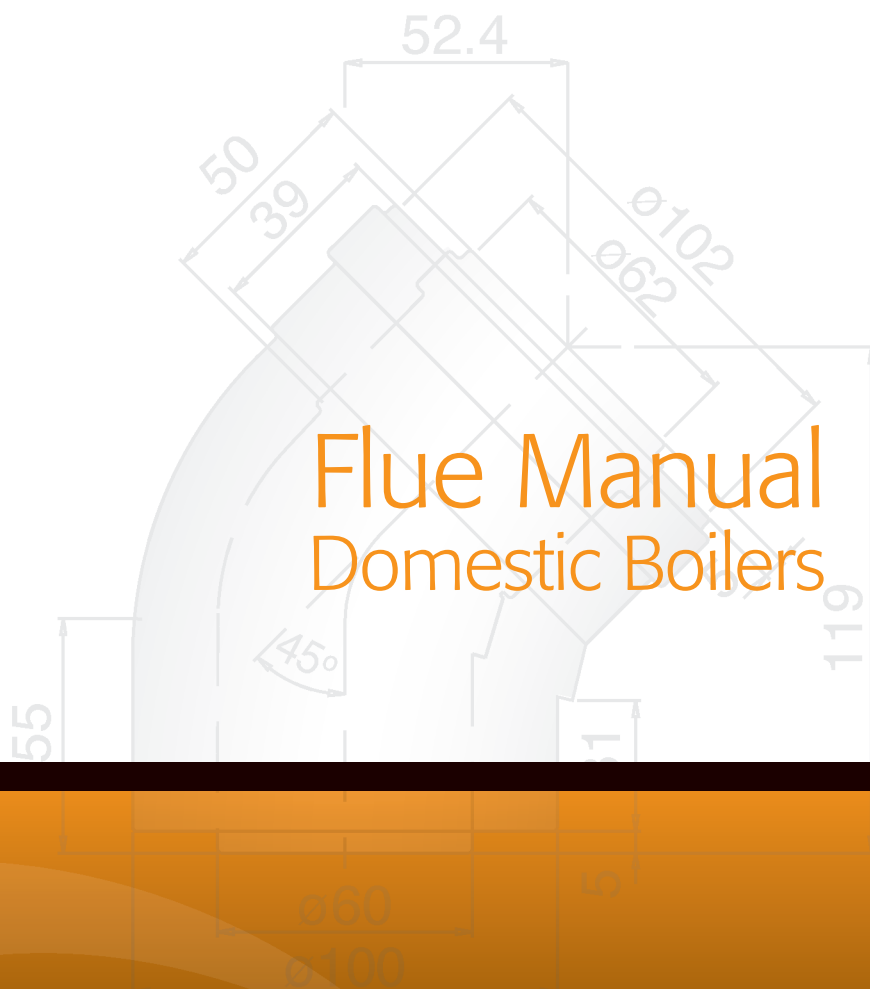

Flue Manual Domestic Boilers



Content

Section 1: Boiler dimensions and minimum clearances	Page number
MODENA C HE	4
MODENA S HE	5
T-ONE	6
DOMICONDENS HE 26C	7
OPTIMAX HE PLUS C	8
OPTIMAX HE PLUS S	9
OPTIMAX HE PLUS 18OV	10
OPTIMAX HE PLUS 25 OV	11
Section 2: Standard flue applications	
HORIZONTAL FLUES: IMPORTANT INFORMATION	12
MODENA C HE / MODENA S HE	13
T-ONE	14
DOMICONDENS HE 26C	15
OPTIMAX HE PLUS C	16
OPTIMAX HE PLUS S	17
OPTIMAX HE PLUS 18 OV	18
OPTIMAX HE PLUS 25 OV	19
Section 3: Flue options – coaxial horizontal and vertical flues	
Maximum permissible flue lengths / flue resistance factors	20
Extended horizontal flue application	21-22
Vertical flue application	23
Section 4: Flue options – 80mm two pipe flues	
Maximum permissible flue lengths / flue resistance factors	24-25
80mm horizontal/vertical applications	26-27
Section 5: Flue options	
Plume displacement kits	28-31
Flues in voids	32-33
Flue terminal positions	34-35
Section 6: Flue Components	
Ferrolì flue components	36-38

All flue pipe and flue components must be supplied by, or specified by, Ferrolì UK Ltd.

The installation must be in accordance with the following;

- 1) The Gas Safety (Installation and Use) Regulations
- 2) The Building Regulations
- 3) BS 5440: Parts 1 and 2
- 4) BS 6798

Modena C HE

Boiler Dimensions and Minimum Clearances

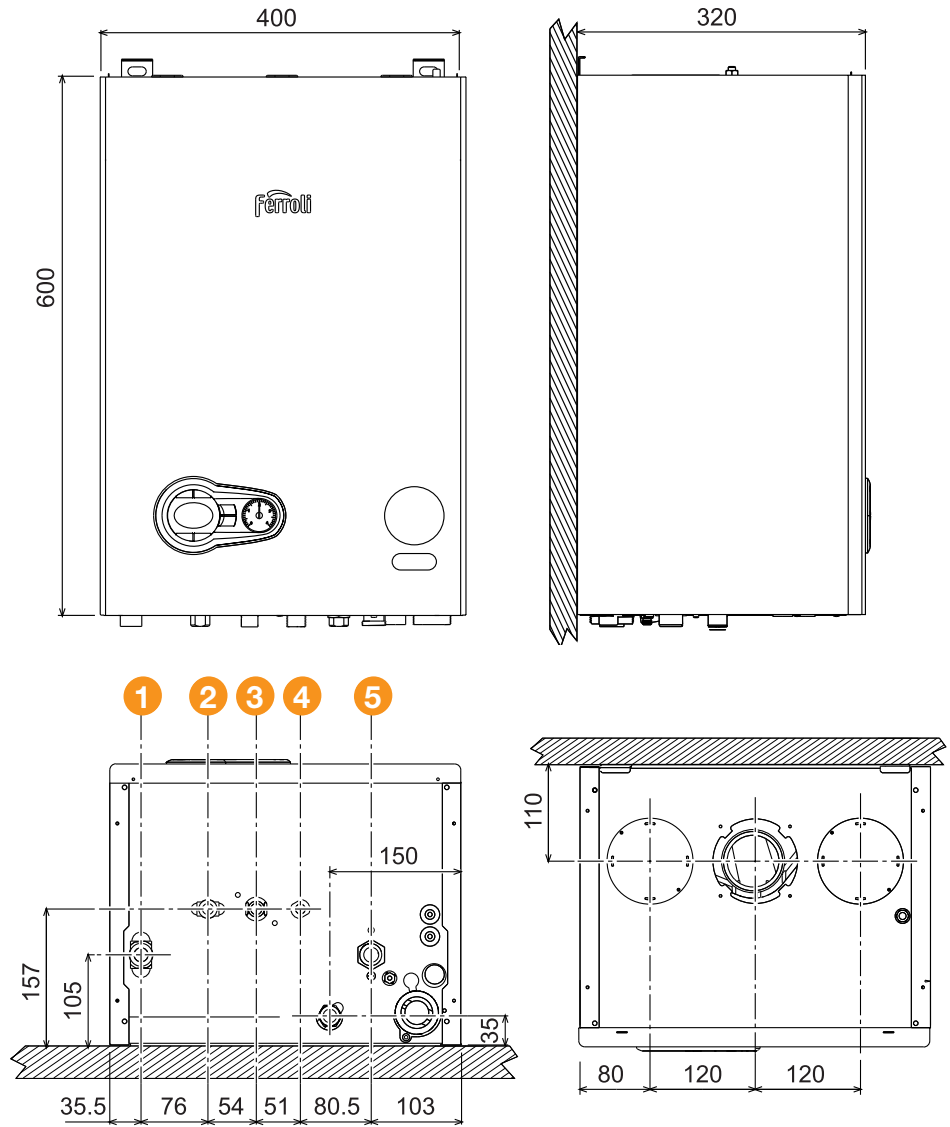

Minimum Clearances Required

Above	300mm
Sides	25mm
Front	50mm*
Below	200mm

* 50mm refers to minimum distance between any openable/removable panel (i.e. kitchen unit door).
A minimum 600mm must be available for servicing access.

Key

- 1 CH Flow
- 2 Hot Water Outlet
- 3 Gas Inlet
- 4 Cold Water Inlet
- 5 CH Return

Modena S HE

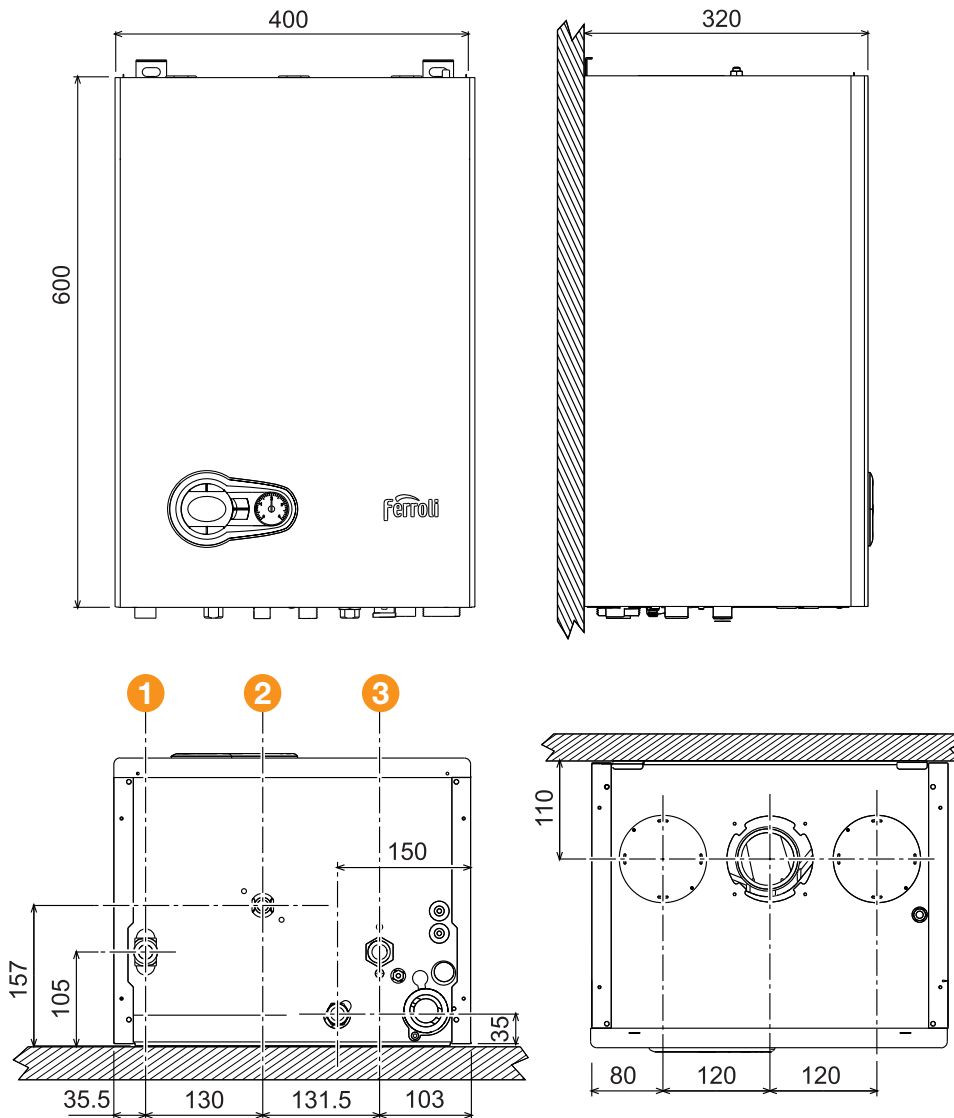

Minimum Clearances Required

Above	300mm
Sides	25mm
Front	50mm*
Below	200mm

* 50mm refers to minimum distance between any openable/removable panel (i.e. kitchen unit door).
A minimum 600mm must be available for servicing access.

Key

- ① CH Flow
- ② Gas Inlet
- ③ CH Return

T-ONE

Boiler Dimensions and Minimum Clearances

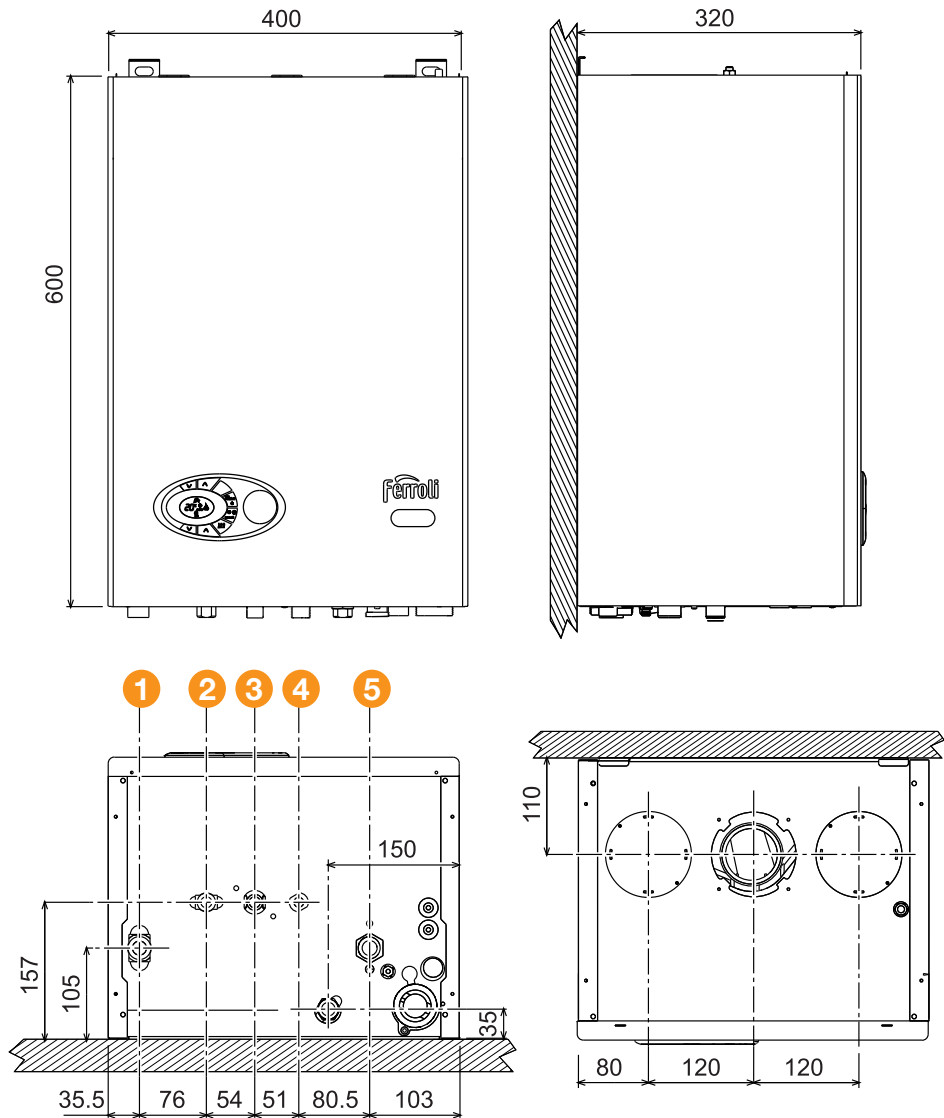

Minimum Clearances Required

Above	300mm
Sides	25mm
Front	50mm*
Below	200mm

* 50mm refers to minimum distance between any openable/removable panel (i.e. kitchen unit door).
A minimum 600mm must be available for servicing access.

Key

- 1 CH Flow
- 2 Hot Water Outlet
- 3 Gas Inlet
- 4 Cold Water Inlet
- 5 CH Return

DOMIcondens HE 26c

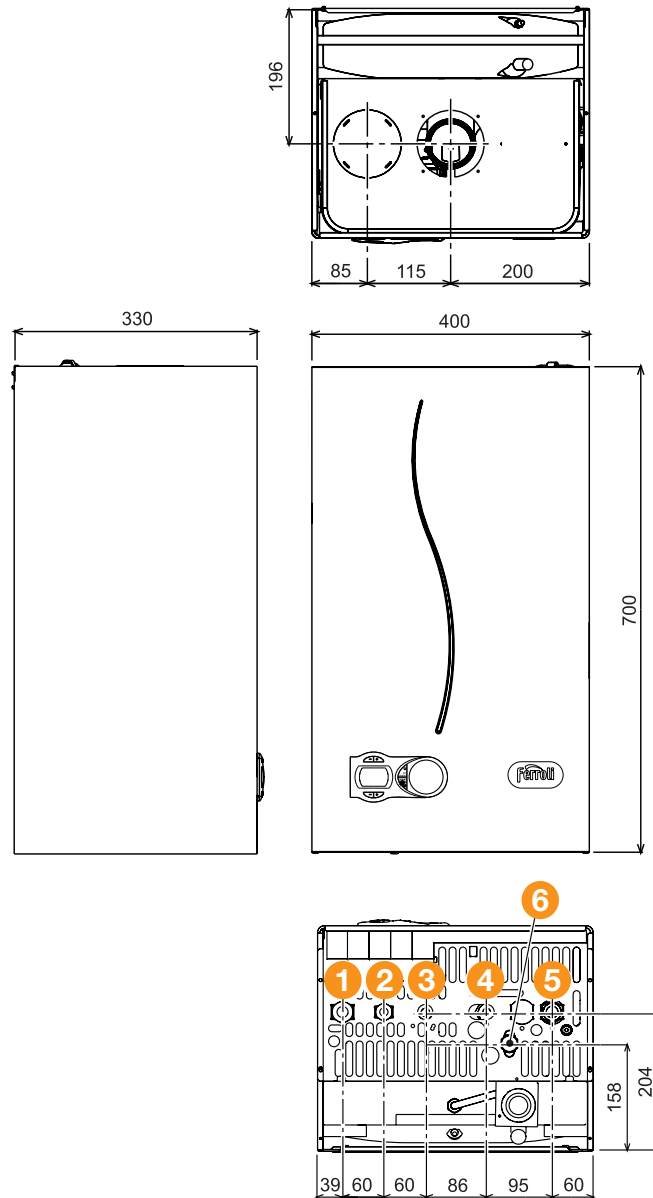

Minimum Clearances Required

Above	300mm
Sides	25mm
Front	50mm*
Below	200mm

* 50mm refers to minimum distance between any openable/removable panel (i.e. kitchen unit door).
A minimum 600mm must be available for servicing access.

Key

- | | |
|---|------------------|
| 1 | CH Flow |
| 2 | Hot Water Outlet |
| 3 | Gas Inlet |
| 4 | Cold Water Inlet |
| 5 | CH Return |
| 6 | Safety Valve |

Optimax HE Plus c

Boiler Dimensions and Minimum Clearances

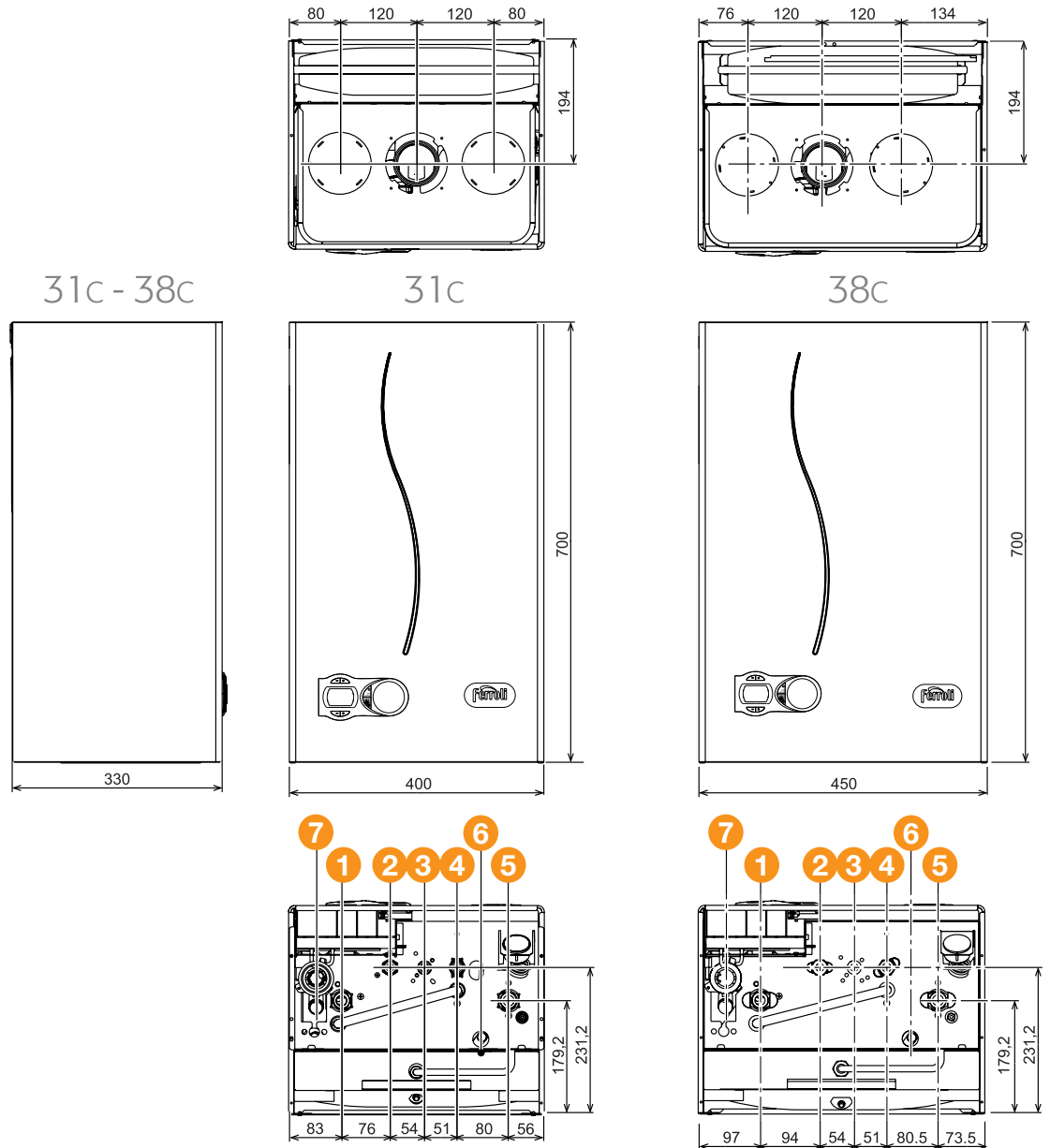

Minimum Clearances Required

Above	300mm
Sides	25mm
Front	50mm*
Below	200mm

* 50mm refers to minimum distance between any openable/removable panel (i.e. kitchen unit door).
A minimum 600mm must be available for servicing access.

Key

- 1 CH Flow
- 2 Hot Water Outlet
- 3 Gas Inlet
- 4 Cold Water Inlet
- 5 CH Return
- 6 Safety Valve
- 7 Condensate Outlet

Optimax HE Plus s

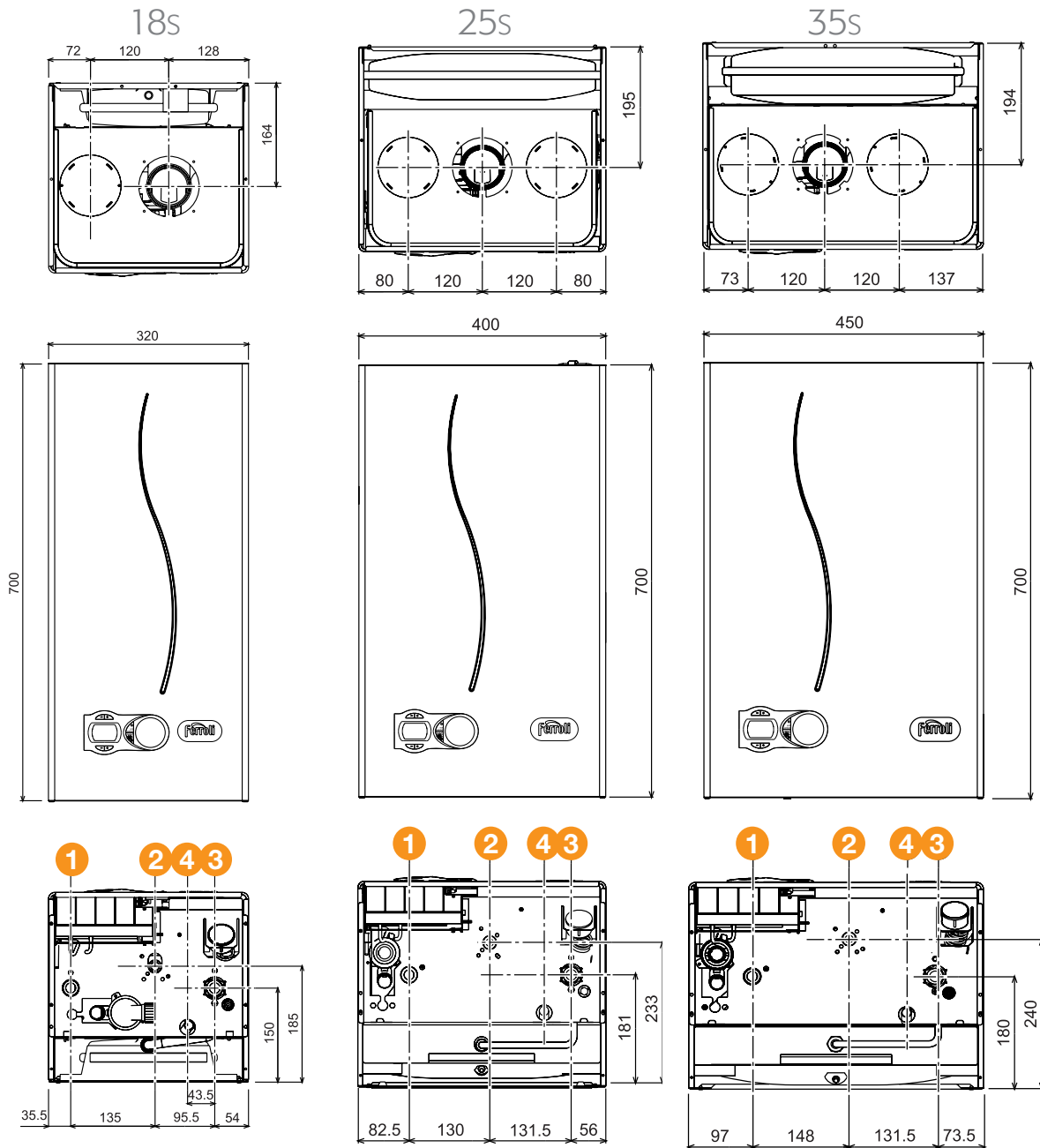

Minimum Clearances Required

Above	300mm
Sides	25mm
Front	50mm*
Below	200mm

* 50mm refers to minimum distance between any openable/removable panel (i.e. kitchen unit door).
A minimum 600mm must be available for servicing access.

Key

- ① CH Flow
- ② Gas Inlet
- ③ CH Return
- ④ Safety Valve

Optimax HE Plus 180v

Boiler Dimensions and Minimum Clearances

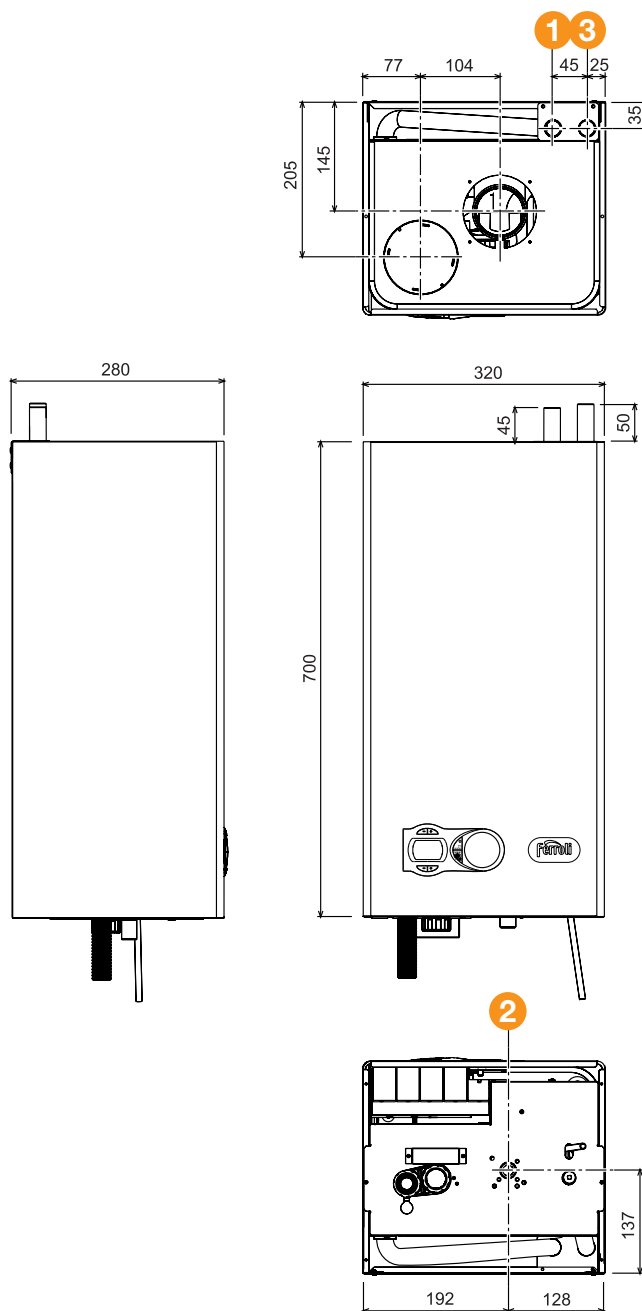

Minimum Clearances Required

Above	300mm
Sides	25mm
Front	50mm*
Below	200mm

Key

- 1 CH Flow
- 2 Gas Inlet
- 3 CH Return

* 50mm refers to minimum distance between any openable/removable panel (i.e. kitchen unit door).
A minimum 600mm must be available for servicing access.

Optimax HE Plus 250v

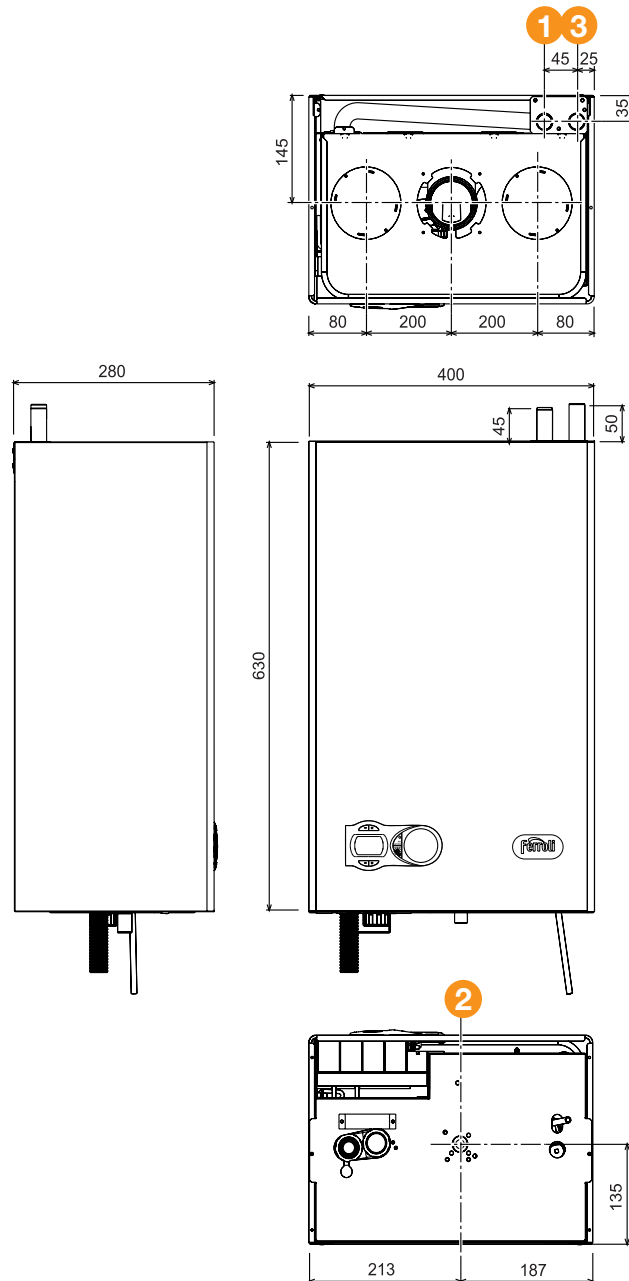

Minimum Clearances Required

Above	300mm
Sides	25mm
Front	50mm*
Below	200mm

Key

- 1 CH Flow
- 2 Gas Inlet
- 3 CH Return

* 50mm refers to minimum distance between any openable/removable panel (i.e. kitchen unit door).
A minimum 600mm must be available for servicing access.

Important Information

- When installing the standard horizontal flue (including both the 600mm telescopic flue terminal and the 1000mm horizontal non-telescopic flue terminal) IT IS IMPORTANT THAT THE FLUE TERMINAL (Fig.1. a) IS FITTED LEVEL. There is an inbuilt fall of the inner flue pipe to allow condensate to drain back to the boiler.
- If it is necessary to extend the flue then ALL EXTENSIONS (Fig. 1.b) MUST FALL BACK TO THE BOILER A MINIMUM OF 3° (55mm per metre) to enable any condensate to drain. All extensions and flue components must be installed with the socket end to the terminal and the spigot end to the boiler.

Fig 1

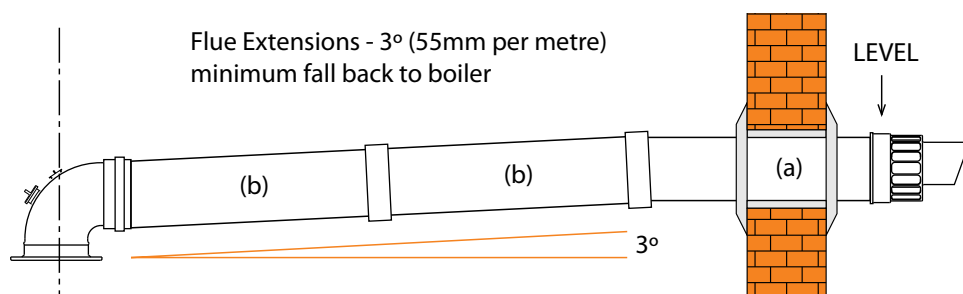

Make a hole of diameter 10-20 mm greater than the nominal diameter of the concentric pipe used. If necessary, cut the terminal length to size, ensuring that the external pipe protrudes from the wall by between 10 and 60mm. Remove the cutting burrs.

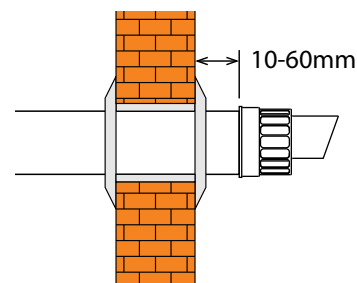

- The telescopic section of the flue should be secured using a self tapping screw and the joint then taped.
- Connect flue to the boiler, positioning the seals correctly. Seal the flue into the wall with silicone or sand + cement and cover with Wall Seals provided.
- Flue seals should be lubricated with a silicone type grease to prevent damage (grease not supplied).



Modena C HE / Modena S HE

Standard Telescopic Flue Kit

Code – 041049G0
 Please note: A nominal 1m
 non-telescopic flue terminal is available
 on request. Code – 1KWMA56W

Includes;

- 1 x Appliance Bend + gasket (a)
- 1 x 600mm Telescopic Flue Terminal (b)
- 2 x Wall Seal – inner and outer (c)

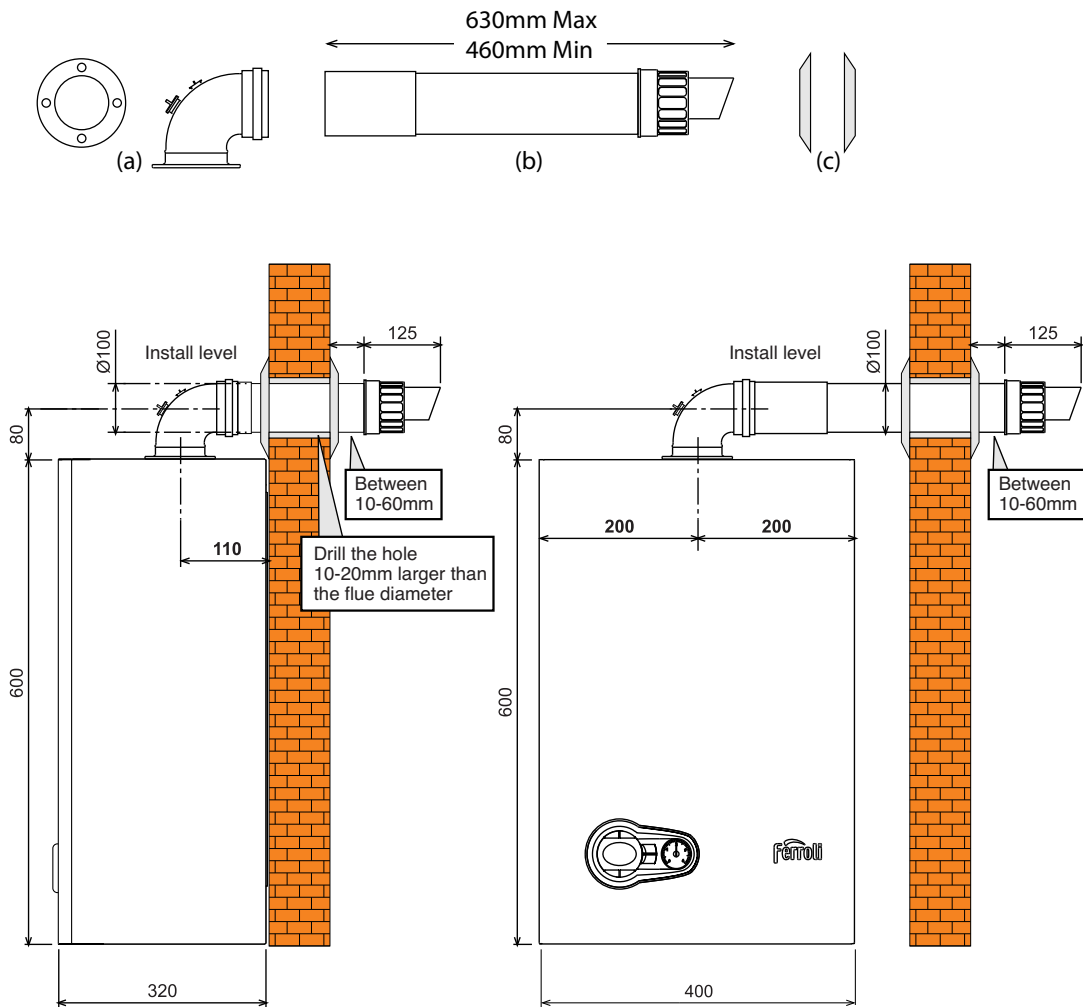

	100mm Concentric		125mm Concentric		80mm Two Pipe System
	Horizontal	Vertical	Horizontal	Vertical	
Maximum Flue Length	7m	8m	28m	28m	80m – 27C HE 70m – 32C HE 70m – S HE

For further flue options see Section 3

T-ONE

Standard Telescopic Flue Kit

Code – 041049G0
 Please note: A nominal 1m non-telescopic flue terminal is available on request. Code – 1KWMA56W

Includes;

- 1 x Appliance Bend + gasket (a)
- 1 x 600mm Telescopic Flue Terminal (b)
- 2 x Wall Seal – inner and outer (c)

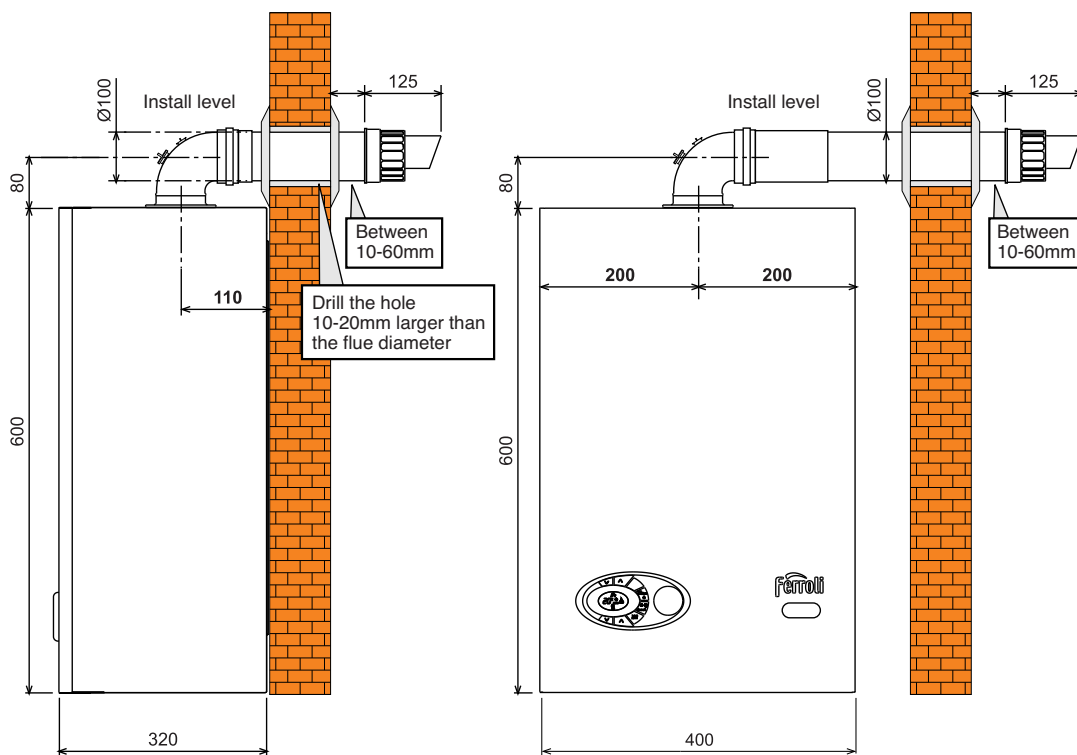
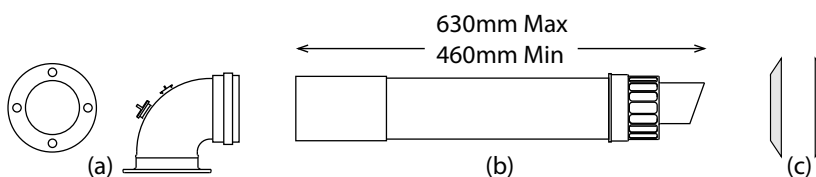

	100mm Concentric		125mm Concentric		80mm Two Pipe System
	Horizontal	Vertical	Horizontal	Vertical	
Maximum Flue Length	7m	8m	28m	28m	80m – 25C HE 70m – 30C HE

For further flue options see Section 3

DOMIcondens HE 26c

Standard Non-Telescopic Flue Kit

Code – 041025G0

Includes;

1 x Appliance Bend + gasket (a)

1 x 1 Metre Non-Telescopic Flue Terminal (b)

2 x Wall Seal – inner and outer (c)

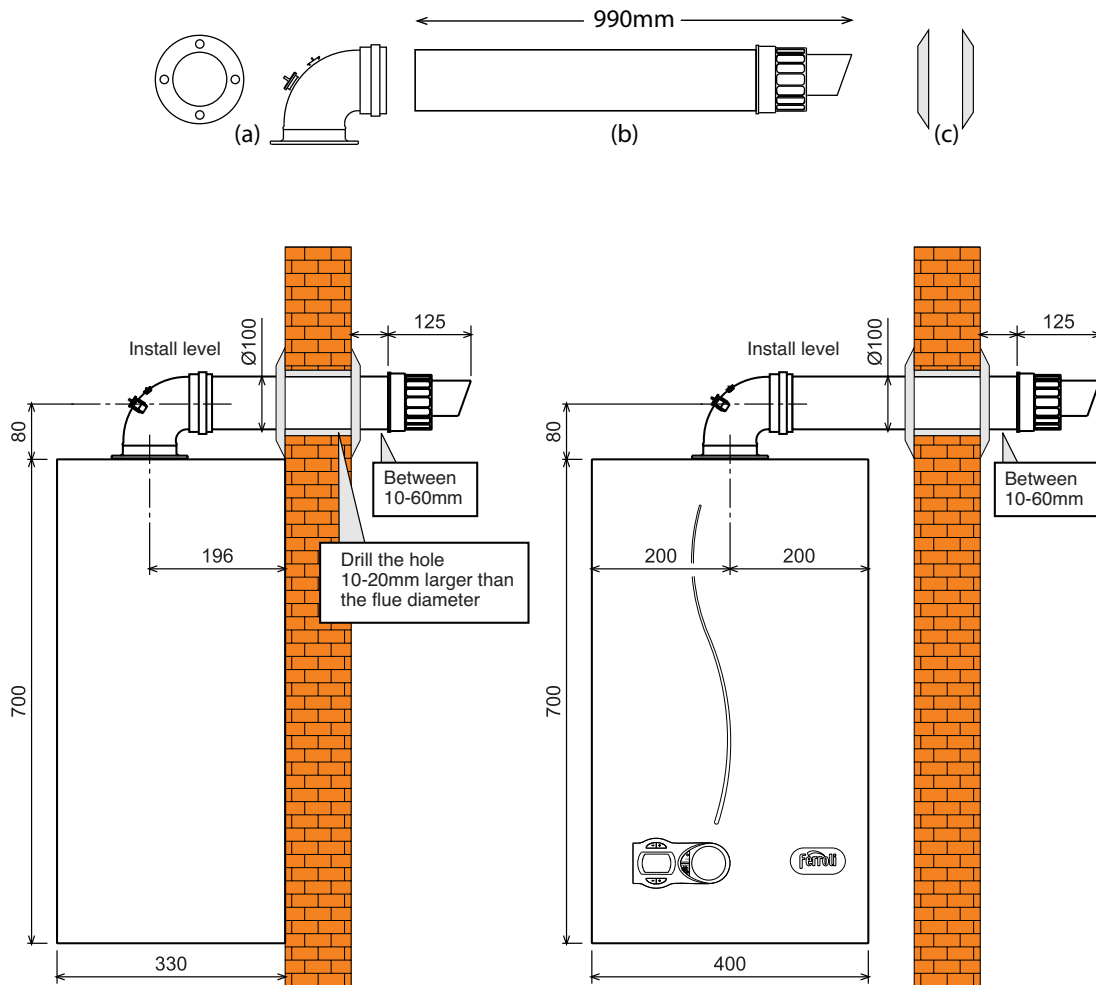

Please note: The pre-fitted 45mm flue baffle is correct for the Standard Flue Application.
If the flue is extended then refer to the installation instructions for the correct baffle size.

	100mm Concentric		125mm Concentric		80mm Two Pipe System
	Horizontal	Vertical	Horizontal	Vertical	
Maximum Flue Length	6m	6m	12m	12m	55m

For further flue options see Section 3

Optimax HE Plus c

Standard Non-Telescopic Flue Kit

Code – 041025G0

Includes;

- 1 x Appliance Bend + gasket (a)
- 1 x 1 Metre Non-Telescopic Flue Terminal (b)
- 2 x Wall Seal – inner and outer (c)

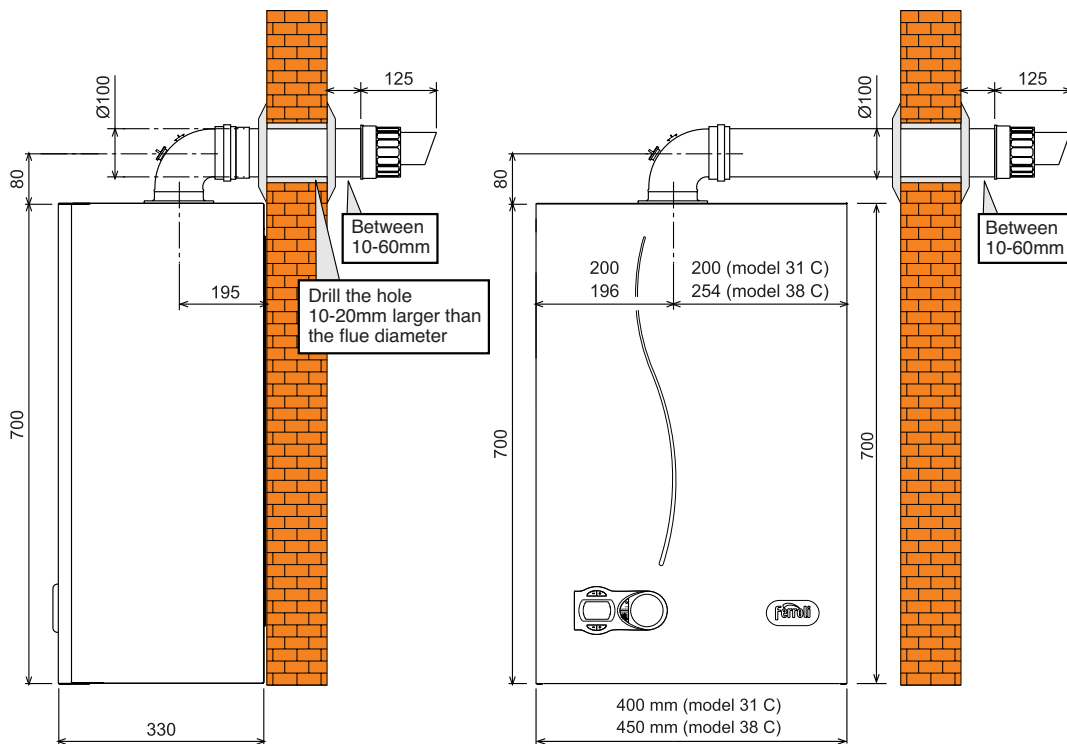
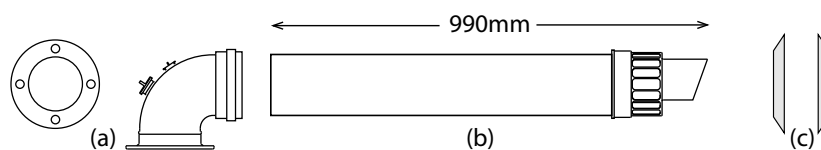

	100mm Concentric		125mm Concentric		80mm Two Pipe System
	Horizontal	Vertical	Horizontal	Vertical	
Maximum Flue Length	7m – HE+31C	8m – HE+31C	28m – HE+31C	28m – HE+31C	75m – HE+31C
	6m – HE+38C	7m – HE+38C	25m – HE+38C	25m – HE+38C	55m – HE+38C

For further flue options see Section 3

Optimax HE Plus s

Standard Non-Telescopic Flue Kit

Code – 041025G0

Includes;

- 1 x Appliance Bend + gasket (a)
- 1 x 1 Metre Non-Telescopic Flue Terminal (b)
- 2 x Wall Seal – inner and outer (c)

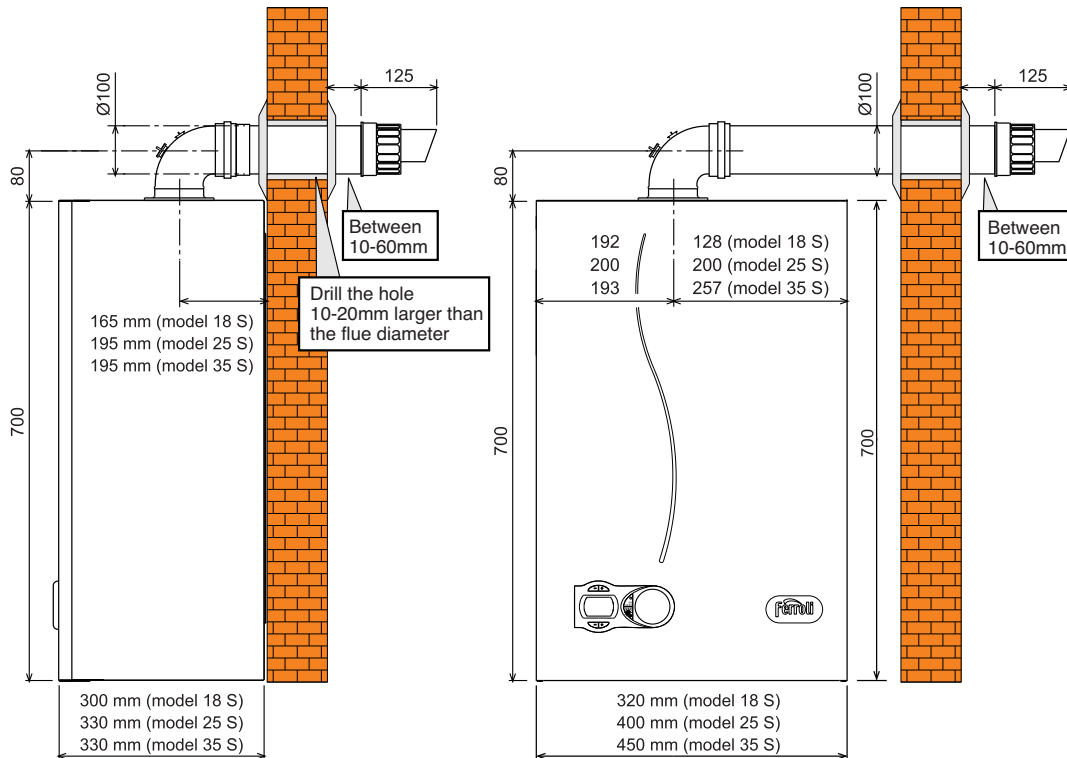
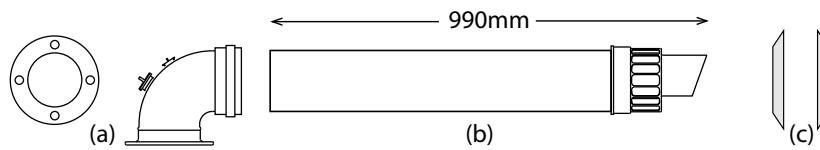

	100mm Concentric		125mm Concentric		80mm Two Pipe System
	Horizontal	Vertical	Horizontal	Vertical	
Maximum Flue Length	8m – 18S 7m – 25S 6m – 35S	9m – 18S 8m – 25S 7m – 35S	30m – 18S 28m – 25S 25m – 35S	30m – 18S 28m – 25S 25m – 35S	95m – 18S 75m – 25S 55m – 35S

For further flue options see Section 3

Optimax HE Plus 180v

Standard Non-Telescopic Flue Kit

Code – 041025G0

Includes;

1 x Appliance Bend + gasket (a)

1 x 1 Metre Non-Telescopic Flue Terminal (b)

2 x Wall Seal – inner and outer (c)

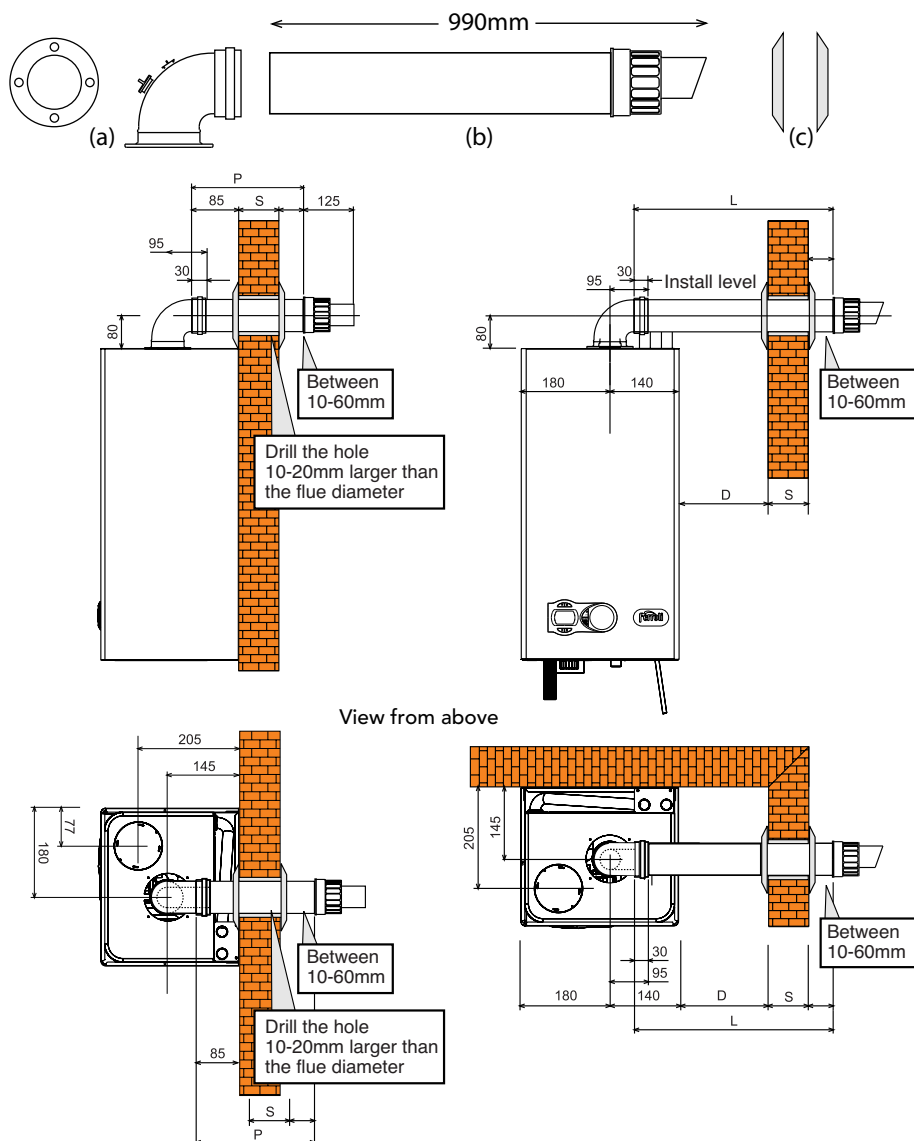

	100mm Concentric		125mm Concentric		80mm Two Pipe System
	Horizontal	Vertical	Horizontal	Vertical	
Maximum Flue Length	5m	6m	15m	16m	95m

For further flue options see Section 3

Optimax HE Plus 25ov

Standard Non-Telescopic Flue Kit

Code – 041025G0

Includes;

1 x Appliance Bend + gasket (a)

1 x 1 Metre Non-Telescopic Flue Terminal (b)

2 x Wall Seal – inner and outer (c)

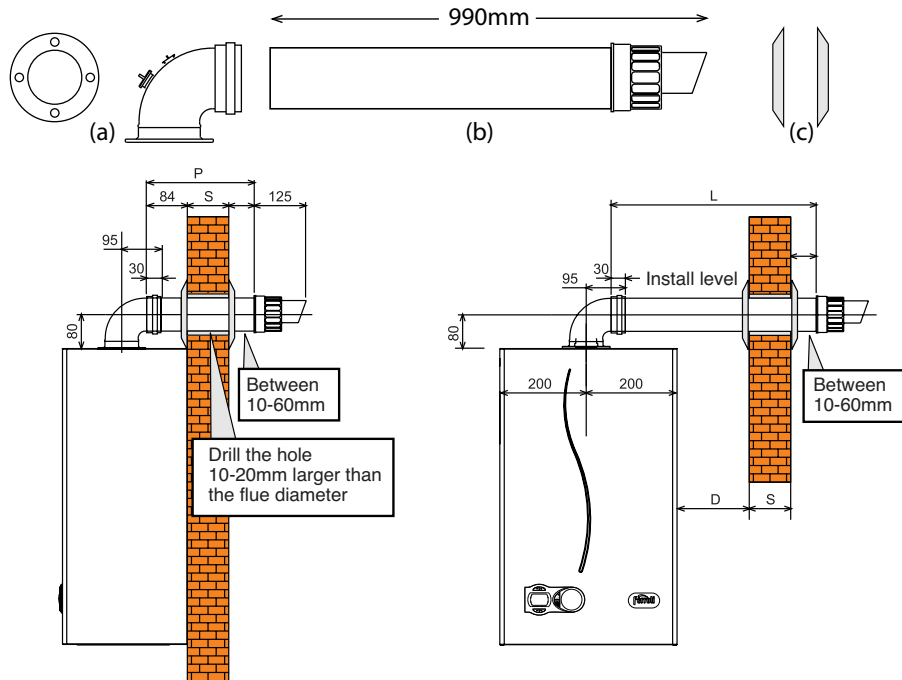

View from above

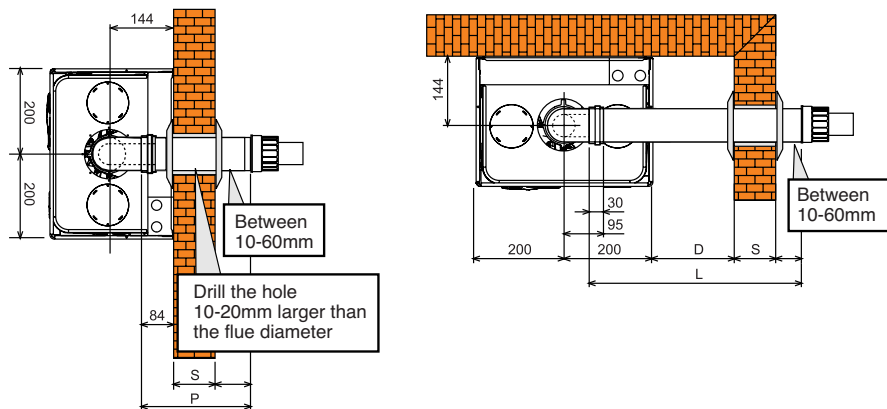

	100mm Concentric		125mm Concentric		80mm Two Pipe System
	Horizontal	Vertical	Horizontal	Vertical	
Maximum Flue Length	5m	6m	15m	16m	75m

For further flue options see Section 3

Maximum permissible flue lengths and flue component resistance tables

Table 1 Coaxial Flue: Maximum permissible flue length

Model	Horizontal		Vertical	
	60/100mm	80/125mm	60/100mm	80/125mm
Modena C HE / Modena S HE / T ONE	7m	28m	8m	28m
DOMIcondens HE 26 C	6m	12m	6m	12m
Optimax HE Plus 31 C	7m	28m	8m	28m
Optimax HE Plus 38 C	6m	25m	7m	25m
Optimax HE Plus 18 S	8m	30m	9m	30m
Optimax HE Plus 25 S	7m	28m	8m	28m
Optimax HE Plus 35 S	6m	25m	7m	25m
Optimax HE Plus 18 OV / 25 OV	5m	15m	6m	16m

When calculating resistance factors to determine maximum coaxial horizontal flue lengths, the appliance bend is already allowed for in the stated 'maximum permissible flue length'.



Appliance Bend



90° Bend



45° Bend

Table 2 Coaxial Flue: Resistance factors

Flue Component	Code	Resistance Factor
60/100mm 90° Bend	041051X0	1m
60/100mm 45° Bend	1KWMA64W	0.5m
80/125mm 90° Bend	1KWMA73W	0.5m
80/125mm 45° Bend	1KWMA72W	0.25m

For each additional flue bend the above resistance values must be added to the overall length of the flue, measured from the centre of the 'appliance bend' to the end of the 'terminal'.

Extended horizontal coaxial flue application

Extended horizontal flue application

Example: Modena C HE Description	Code
Standard Telescopic Flue	041049G0
60/100mm 1m Flue Extension	1KWMA57W

Fig 1 Maximum permissible flue length = L

When calculating resistance factors to determine maximum coaxial horizontal flue lengths, the appliance bend is already allowed for in the stated 'maximum permissible flue length'.

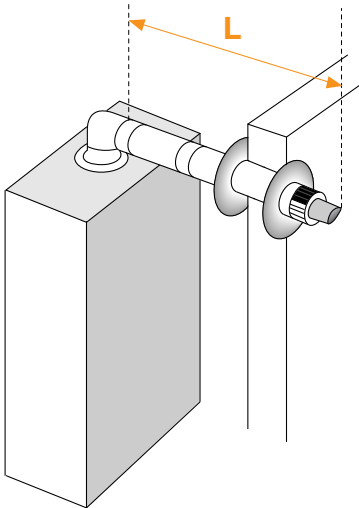

Vertical rise from boiler – terminating horizontally

Example: Optimax HE Plus C Description	Code
① 60/100 Vertical Adapter	041002X0
② 60/100 1m Flue Extension	1KWMA57W
③ 60/100 90° Bend	041051X0
④ 60/100 1m Non-Telescopic Terminal	1KWMA56W

Fig 2 Maximum permissible flue length = A+B+90° Bend

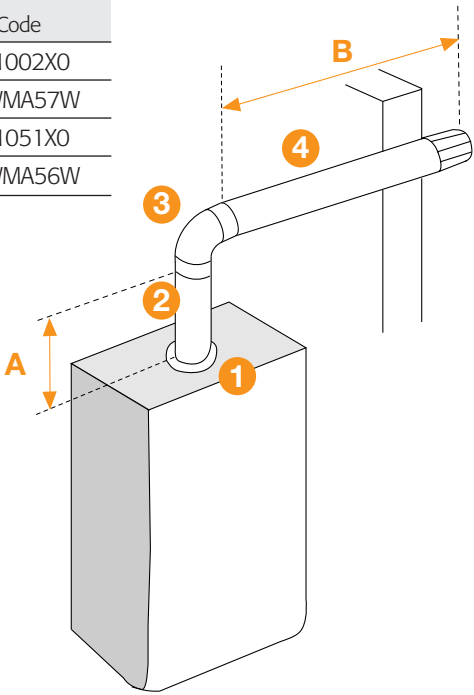

Extended horizontal coaxial flue application

Extended horizontal flue with additional 90° bend

Example: Optimax HE Plus (80/125mm flue)	
Description	Code
① 60/100 to 80/125 Vertical Adapter	041006X0
② 80/125 1m Flue Extension	1KWMA59W
③ 80/125 90° Bend	1KWMA73W
④ 80/125 1m Non-Telescopic Horizontal Terminal	1KWMA58W

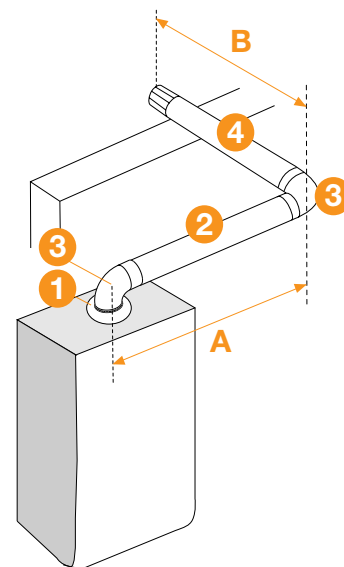

Fig 3

Maximum permissible flue length = A+B + (1 x 90° Bend)

Horizontal flue with 2 x 45° Bends

Example: Modena C HE	
Description	Code
① Appliance Bend	041001X0
② 60/100 1m Flue Extension	1KWMA57W
③ 45° Bend	041051X0
④ 1m Non-Telescopic Terminal	1KWMA56W

Fig 4

Maximum permissible flue length = A+B+C + (2 x 45° Bend)

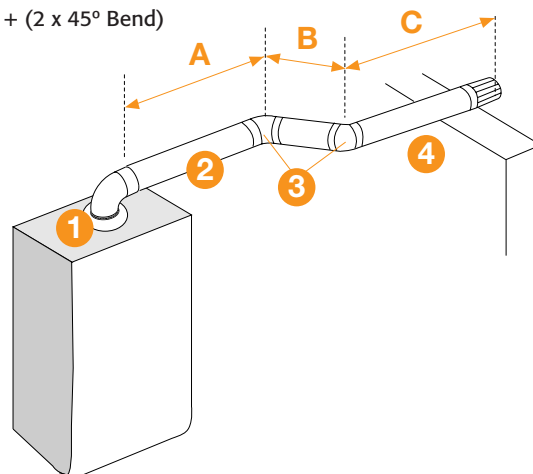

Refer to Tables 1 and 2, page 20

Please Note: When installing the 80/125mm Horizontal Flue it is always necessary to start with the 60/100 to 80/125 Vertical Adapter + the 80/125 – 90° Bend.

Vertical coaxial flue application

- The flue must be adequately supported throughout its length; the boiler must not be allowed to support the weight of the flue.
- This can be achieved by securing the flue with fixing brackets at each socket/spigot joint, every 1.0 metre horizontally and 1.8 metre intervals vertically.
- Each flue extension and flue component is configured with a spigot end and a socket end; the socket must always face uppermost towards the terminal and the spigot face downwards to the boiler.
- If it is necessary to shorten a flue extension, then the cut must be made at the spigot end.
- Under no circumstances must the upper section of the vertical flue terminal (item 4) be cut (i.e. black plastic section).
- The correct vertical adapter must be used directly off the boiler.

Vertical flue application - 60/100mm

Example: Modena C HE		
Description		Code
① 60/100 Vertical Adapter		041002X0
② 60/100 1m Flue Extension		1KWMA57W
③ Pitched Roof Slate		1KWMA82U
④ 60/100 Vertical Terminal		1KWUK356
⑤ 100mm Support Bracket		1KWMR46A

When using the 60/100mm vertical flue terminal the distance from the roof intersection (Fig.6 – D) is pre-determined by the compatible roof slate – Code: 1KWMA82U

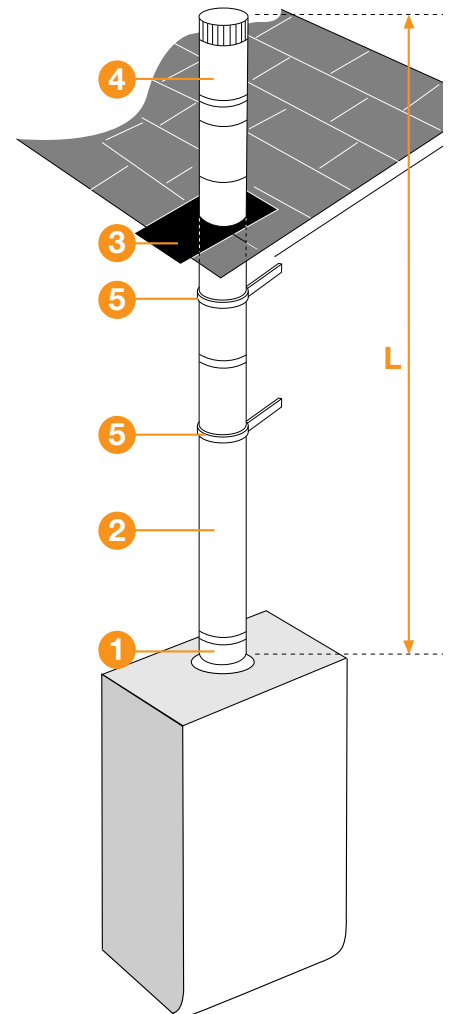

Fig 5 Maximum permissible flue length = L

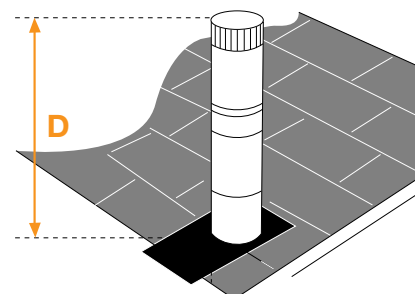

Fig 6

80mm two pipe flue application

- When installing 80mm two pipe horizontal flue system, it is important to incorporate a minimum fall of 3° (55mm per metre) to enable any condensate to drain back to the boiler. The air section is to be installed level or with a slight fall away from the boiler to avoid rain entry (see Fig.7). The air terminal should be fitted below or to the side of the flue gas terminal.
- The 80mm translucent pipe is not intended for external installation. Where the flue exits the wall the special external terminal section must be used. This section is specifically designed with spigot/spigot ends which allow for the push on terminal.
- All flue pipes and components are configured with a spigot and socket, these must be installed with the socket end to the terminal and the spigot end to the boiler.
- The flue must be adequately supported throughout its entire length. Fixing brackets must be installed at maximum intervals of 1m horizontally and 1.8m vertically.

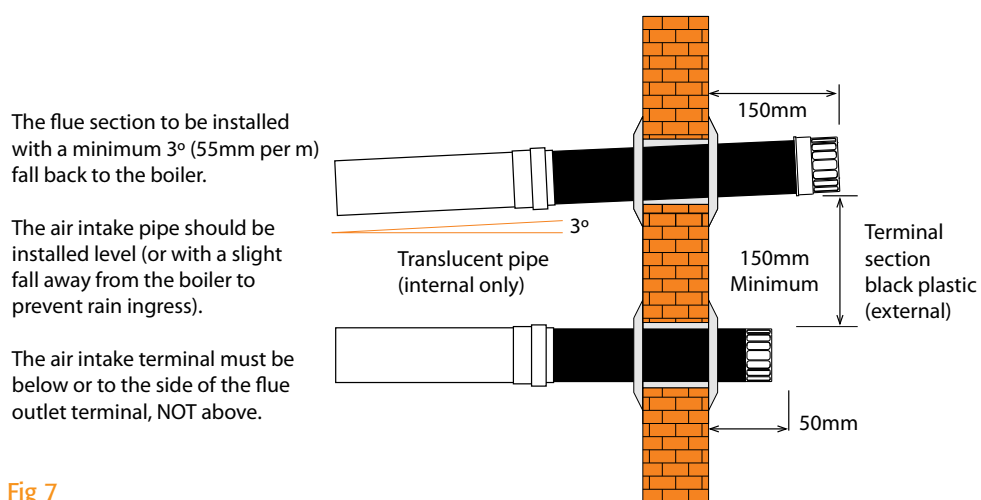

Fig 7

Table 3

80mm two pipe flue: Maximum permissible flue length

Model	Flue Length	Model	Flue Length
MODENA 27C HE	80m	OPTIMAX HE PLUS 18 S	95m
MODENA 32C HE	70m	OPTIMAX HE PLUS 25 S	75m
MODENA S HE (ALL MODELS)	70m	OPTIMAX HE PLUS 35 S	55m
DOMICONDENS HE 26 C	55m	OPTIMAX HE PLUS 18 OV	95m
OPTIMAX HE PLUS 31 C	75m	OPTIMAX HE PLUS 25 OV	75m
OPTIMAX HE PLUS 38 C	55m		

Flue calculations

To ensure this maximum length is not exceeded it is necessary to make a simple calculation prior to installation

- Each component is provided with an 'equivalent loss' in linear metres. This 'equivalent loss' is compared to the loss (resistance) of one metre of flue.
- This loss varies depending on the position of installation (i.e. horizontally or vertically) and whether the pipe or component is used on the flue gas/exhaust section or the air intake section (see table 4).
- Table 4 shows the resistance factors for each component (for example a 90° bend has a resistance factor of 2m if fitted on the flue gas section but only 1.5m if on the air intake section).
- A one metre length of 80mm pipe on the flue gas section has a resistance factor of 2m, when installed horizontally but only 1.6m vertically.
- Measure the total length of pipe (x by the resistance factor) and add the resistance of each fitting, using the resistance factors shown in Table 4.

Table 4

80mm two pipe flue: Resistance factors

Flue Component	Code	Resistance Factor
80mm Two Pipe Adapter (Flue Gas & Air)	041039X0	0.3m (each)
Horizontal Pipe – Flue	222952 (1m length)	2.0m
Horizontal Pipe – Air	222952 (1m length)	1.0m
Vertical Pipe – Flue	222952 (1m length)	1.6m
Vertical Pipe – Air	222952 (1m length)	1.0m
90° Bend – Flue	222955	2.0m
90° Bend – Air	222955	1.5m
45° Bend – Flue	222954	1.8m
45° Bend – Air	222954	1.2m
Flue Terminal – Horizontal	1KWMA86A	5.0m
Air Intake Terminal – Horizontal	1KWMA85A	2.0m
External terminal section (black plastic)	ZU800008127 (1m)	1.0m
Vertical Flue Terminal (80/80 to 80/125)	010027X0	12.0m

Horizontal flue

80mm two pipe horizontal flue

Example: Flue length A=1m B=9m C=9m D=1m					
Description	Code	Resistance Factor		Total	
		Flue	Air		
1 80mm Adapter	041039X0	0.3	0.3	0.6	
2 90° Bend	222955	2.0	1.5	3.5	
3 80mm Pipe (per 1m length)	222952	Horizontal	18.0	9.0	27.0
		Vertical	1.6	1.0	2.6
4 Terminal – Flue	1KWMA86A	5.0	-	5.0	
4 Terminal – Air	1KWMA85A	-	2.0	2.0	
Total resistance value in metres				40.7	

Maximum permissible flue length =

$A+B+C+D \times (\text{resistance factor}) + \text{Resistance of components 1, 2, and 4}$

Refer to Tables 3 and 4, pages 24/25

Fig 8

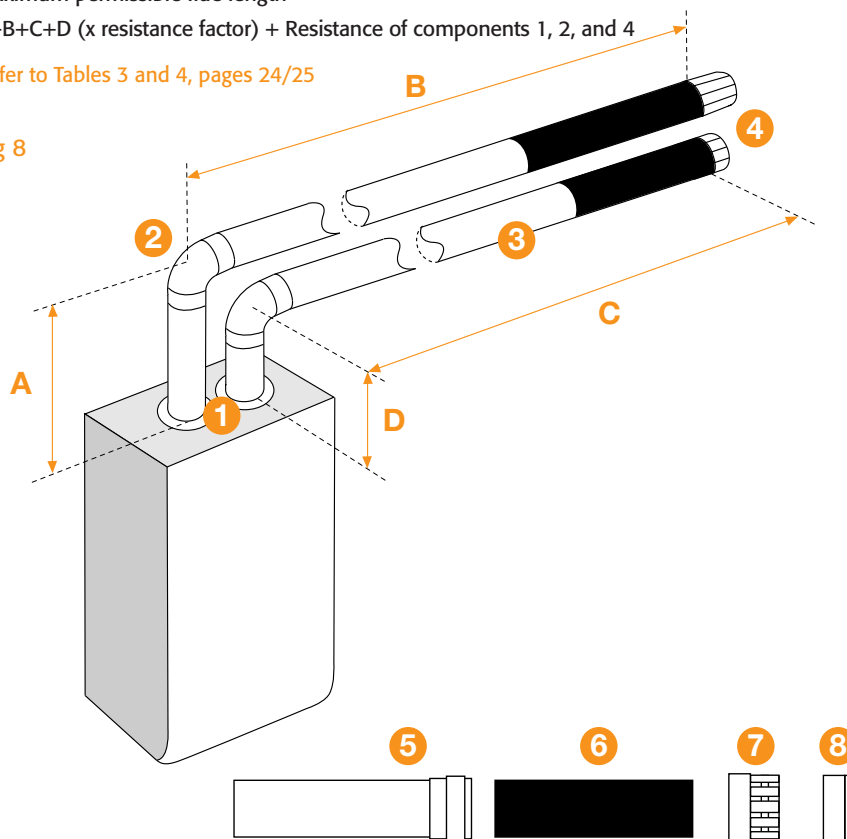

Description	Code
5 Translucent Pipe – spigot/socket	222952
6 Terminal Section – spigot/spigot (Black Plastic)	ZU800008127
7 Flue terminal	1KWMA86A
8 Air terminal	1KWMA85A

Vertical flue

80mm two pipe vertical flue

Example: Flue length A = 8m				
Description	Code	Resistance Factor		Total
		Flue	Air	
❶ 80mm Adapter	041039X0	0.3	0.3	0.6
❷ 80mm Pipe (per 1m length)	222952	Horizontal	–	–
		Vertical	12.8	8.0
❸ Vertical Flue Terminal (80/80 – 80/125)	010027X0			12.0
Total resistance value in metres				33.4

Maximum permissible flue length =

Distance A – Flue & Air (x resistance factor) + Resistance of Vertical Flue Terminal

Refer to Tables 3 and 4, pages 24/25

Fig 9

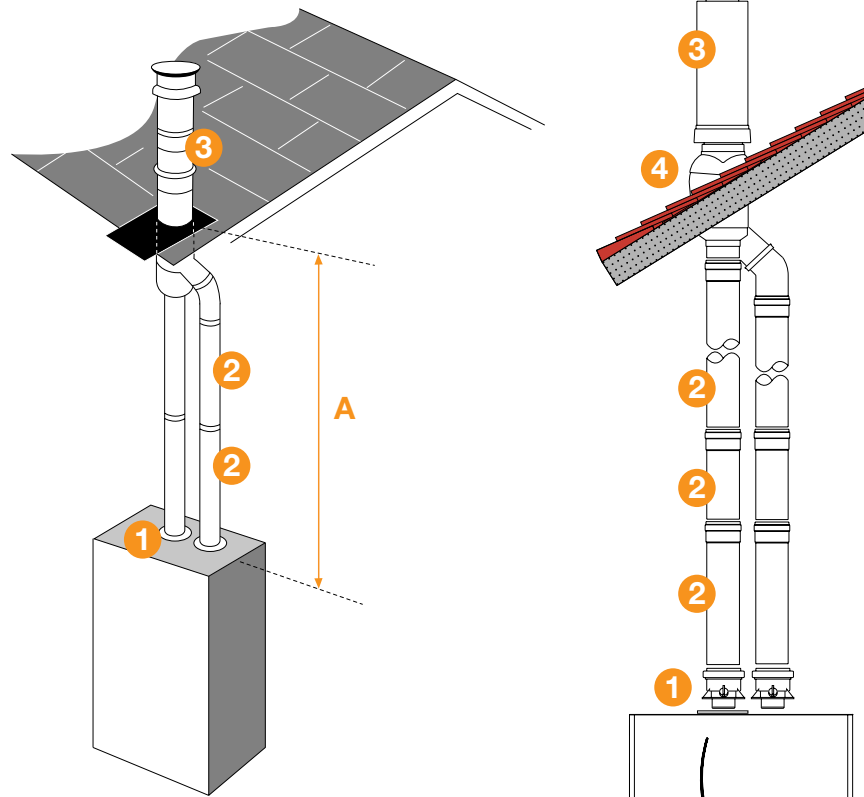

Description	Code
❶ 80mm Adapter	041039X0
❷ Translucent Pipe	222952
❸ Vertical Flue Terminal (80/80 – 80/125)	010027X0
❹ Pitched Roof Slate	1KWMA82U

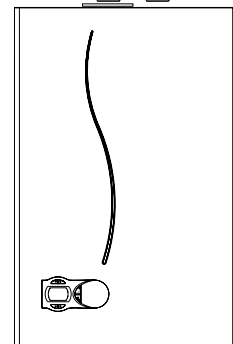

Plume displacement kit

Plume Displacement Kit – Code: 041042G0

The Plume displacement kit fits onto the Optimax HE Plus, DOMIcondens and Modena HE boilers.

This kit contains all components to allow for safe extraction and management of flue gases and to supply air for combustion.

This kit enables the flue products to be exhausted further away from the air inlet, thereby reducing the visual impact of pluming.

It can be used to overcome many site issues as illustrated in these instructions.

The flue outlet supplied terminates horizontally.

Siting can either be on a wall face with the terminal exhausting at right angles (or 45°) to the wall, or above the eaves of a building.

Terminals exhausting vertically above the eaves may need additional support.

Please note that the plume kit should not be used to circumvent correct terminal locations as described in BS 5440:1 and Building Regulations Approved Document J.

Vertical

Maximum installation length 10 metres from air inlet to top of horizontal terminal.

Minimum installation length 500mm from air inlet to top of horizontal terminal.

For each additional metre length on standard horizontal flue reduce Plume Management Kit equivalent length by 3 metres.

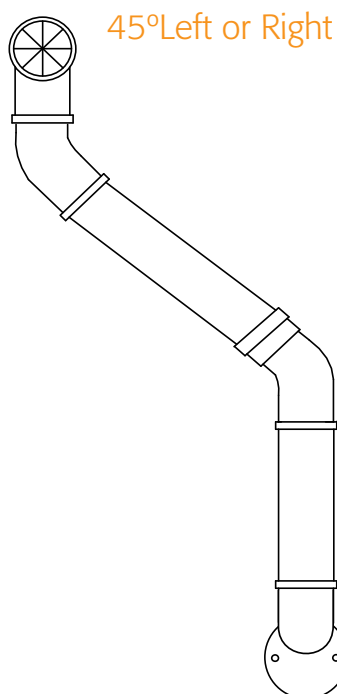
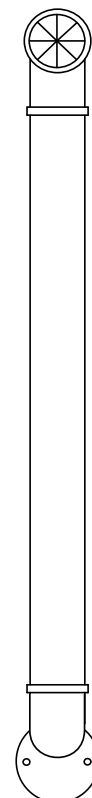

45° Left or Right

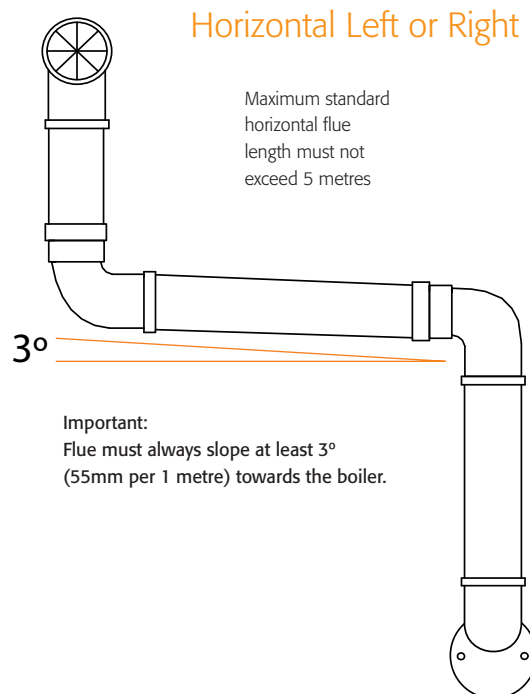

Horizontal Left or Right

Maximum standard horizontal flue length must not exceed 5 metres

Important:
Flue must always slope at least 3° (55mm per 1 metre) towards the boiler.

Plume displacement kit

Dimensions and Content

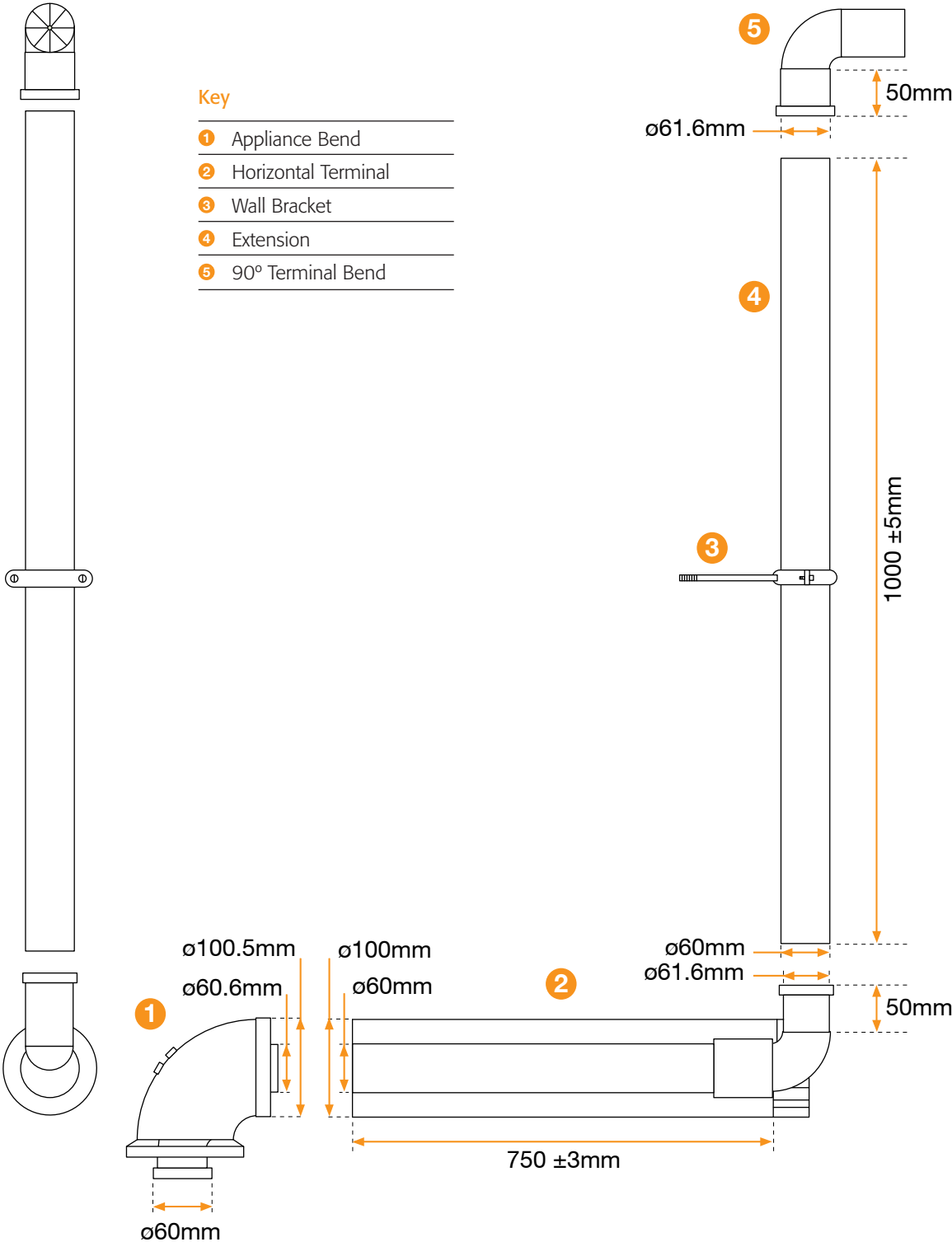

Plume displacement kit

Fixing Instructions

The standard length of the concentric flue is 750mm, this can be extended if required, but will reduce the distance the plume kit can travel (see maximum flue/plume length chart).

The concentric flue kit must be cut to size if the full length is not required. The air intake must terminate flush with the outer fabric of the property. This is to ensure the plume kit pipe does not stand off the wall.

If any cuts need to be made to any part of the flue system, the cuts need to be made square and burrs removed after cutting, failure to do this could result in the seals within the flue to be displaced or damaged.

Make sure any seals in the flue system are fully lubricated before assembly.

Installation

- Remove white flue label from top of the boiler and fully expose the screw holes. Fit the black flue gasket to the appliance bend. Fit elbow to top of boiler and secure with the four fixing screws. It is necessary to lubricate the inner flue seal before fitting.
- From the outside slide the concentric flue through the hole and ease the flue into the elbow making sure the inner flue seal is not being forced out.
- Check the flue is level.
- Seal the wall with silicone or sand and cement.
- The plume kit comes with 1m of plume pipe; extensions are available (see accessory list)
- The plume extension can be cut to size; make sure the cuts are square and any burrs are removed.
- The minimum length of plume kit allowed is 500mm this is to allow adequate fixing.
- When joining plume pipes together make sure and seals are lubricated. When the sections are pushed together take extra care not to damage or dislodge the seal.
- Every 1m section of plume pipe must be secured with a fixing bracket. If the plume kit is to terminate above the eaves additional securing brackets will be required.

Note: Any horizontal section of flue should always have a fall of at least 3° (55mm per metre) back to the boiler.

Code	Part Description	Dimensions
041002G0	Extension	Dia. 60mm x 1000mm
041001G0	Wall bracket	160mm Total
041005G0	45° Bend	Dia. 60mm x 50mm
041000G0	90° Bend	Dia. 60mm x 150mm

Plume displacement kit

Terminal Positions

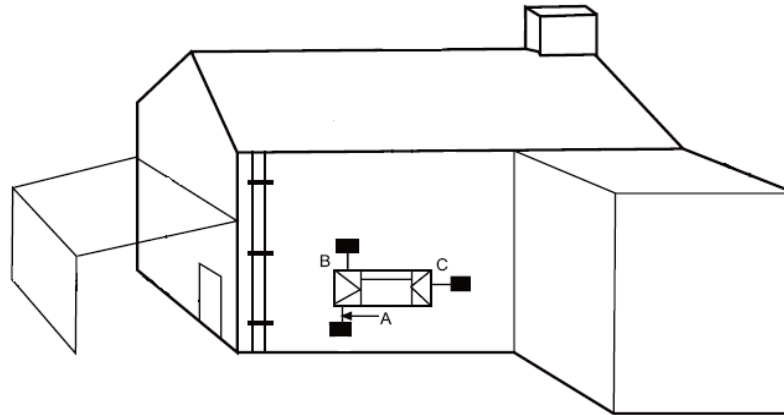

Minimum siting dimensions for terminal positions

A	Directly below an opening, air brick, opening windows	300mm
B	Directly above an opening, air brick, opening windows	300mm
C	Horizontally to an opening, air brick, opening windows	300mm

Minimum siting dimensions for air inlet

A	Directly below an opening window	150mm
B	Directly above an opening window	150mm
C	Horizontally to an opening window	150mm

Note: These measurements are only used in conjunction with the plume displacement kit. If the kit is removed please refer back to boiler installation manual for flue terminal positioning. For further guidance on siting requirements please see boiler installation manual.

Maximum Flue Lengths

Boiler Model	Flue/plume length inc. concentric pipe	Boiler Model	Flue/plume length inc. concentric pipe
MODENA 27C HE	5m	OPTIMAX HE PLUS 38 C	5m
MODENA 32C HE	5m	OPTIMAX HE PLUS 18 S	7m
MODENA S HE (ALL MODELS)	5m	OPTIMAX HE PLUS 25 S	6m
T-ONE	5m	OPTIMAX HE PLUS 35 S	5m
DOMICONDENS HE 26 C	4m	OPTIMAX HE PLUS 18 OV	7m
OPTIMAX HE PLUS 31 C	6m	OPTIMAX HE PLUS 25 OV	6m

OPTIMAX HE Range

- Maximum standard horizontal flue length must not exceed 4m
- For each additional metre length on standard horizontal flue reduce plume displacement kit length by 3m.

Flues in voids

Where the flue is installed in a ceiling or roof void, particular attention must be made to the current Building Regulations with respect to inspection hatches (Ref: GasSafe TB008 flues in voids). The inspection hatches are necessary to allow visual inspection of the entire flue system to ensure;

- The flue is continuous throughout its length
- All joints appear correctly assembled and are appropriately sealed
- The flue is adequately supported throughout its length
- The required gradient of fall back to the boiler has been provided.

Access points to allow visual inspection must be made available at distances shown in the following diagram (Fig 10).

All voids containing concealed flues should have at least one inspection hatch measuring at least 300mm square.

No flue joint within the void should be more than 1.5m distance from the edge of nearest inspection hatch, i.e. dimension 'X' in the diagram should be less than 1.5m.

Where possible inspection hatches should be located at changes of direction. Where this is not possible then bends should be viewable from both directions.

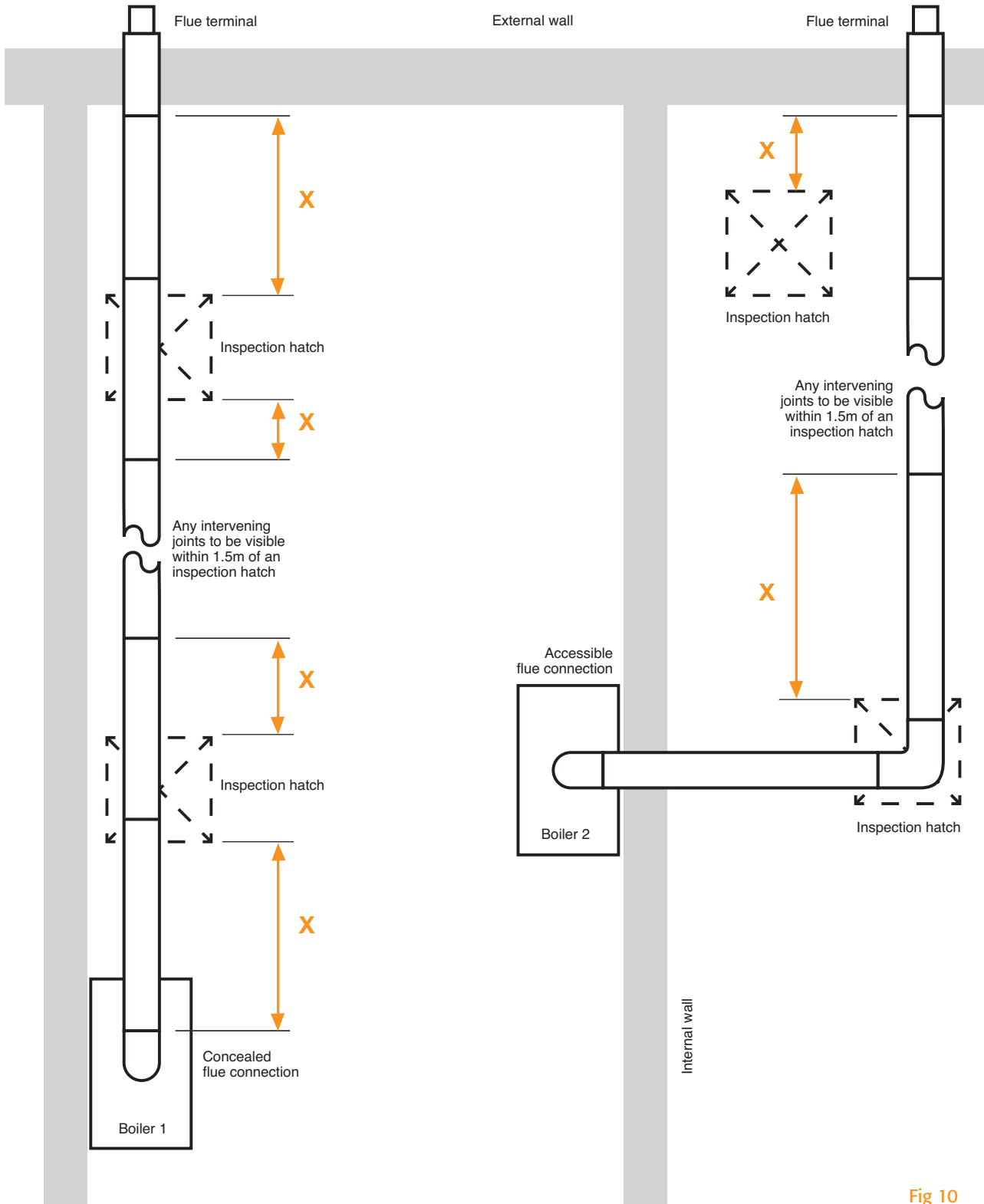
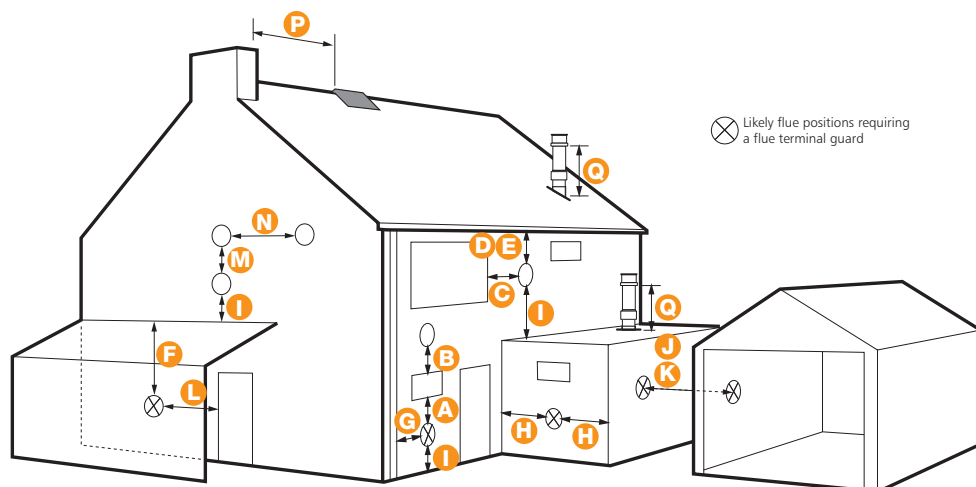

Fig 10

Flue terminal positions



Minimum dimensions of fume exhaust terminals

A	Directly below an opening, air brick, opening windows etc	300mm
B	Above an opening, air brick, opening windows etc	300mm
C	Horizontally to an opening, air brick, opening windows etc	300mm
D	Below gutters, soil pipes or drain pipes	75mm
E	Below eaves	200mm
F	Below balconies or car port	200mm
G	From a vertical drain pipe or soil pipe	150mm
H	From an internal or external corner	100mm
I	Above ground roof or balcony level	300mm
J	From a surface facing the terminal	600mm
K	From a terminal facing the terminal	1200mm
L	From an opening in the car port (i.e. door, window) into the dwelling	1200mm
M	Vertically from a terminal on the same wall	1500mm
N	Horizontally from a terminal on the same wall	300mm
O	From the wall on which the terminal is mounted	N/A
P	From a vertical structure on the roof	300mm
Q	Above intersection with roof	300mm

Note:

In addition the terminal must be at least 150mm (fanned draught) from an opening in the building fabric for the purpose of accommodating a built in element such as a window frame.

Terminal guards must be fitted if the flue is less than 2m from the ground or if a person could come into contact with the flue terminal.

To avoid nuisance 'plumbing' the installer may wish to adopt the guidance in 'The Guide to Condensing Boiler Installation Assessment Procedure for Dwellings' as suggested in Building Regulations Approved Document J.

Flue terminal positions

Where a vertical roof terminal is installed adjacent to a window or opening, it is necessary to ensure that the flue does not penetrate the shaded area as shown in the diagram.

The Flue should not penetrate the shaded area

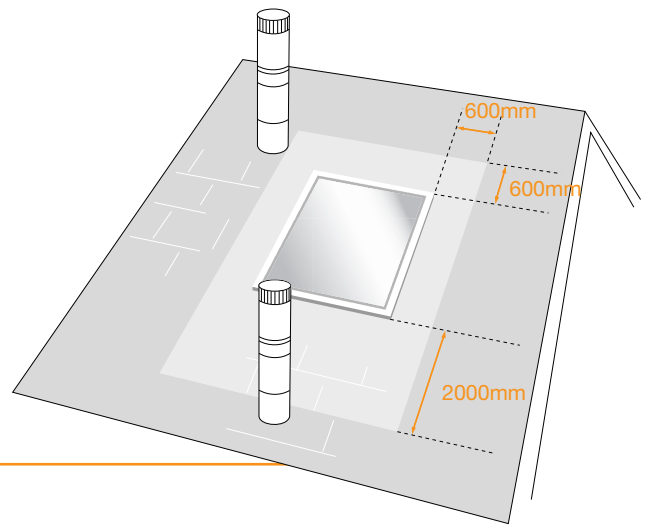

When installing a vertical flue on a flat or sloping roof the termination should be a minimum of 1500mm between the terminal and an opening window or dormer window.

If dimension 'A' is less than 1500mm then the flue must be extended so that dimension 'B' is at least 300mm above the Dormer Roof, window and/or opening into the building.

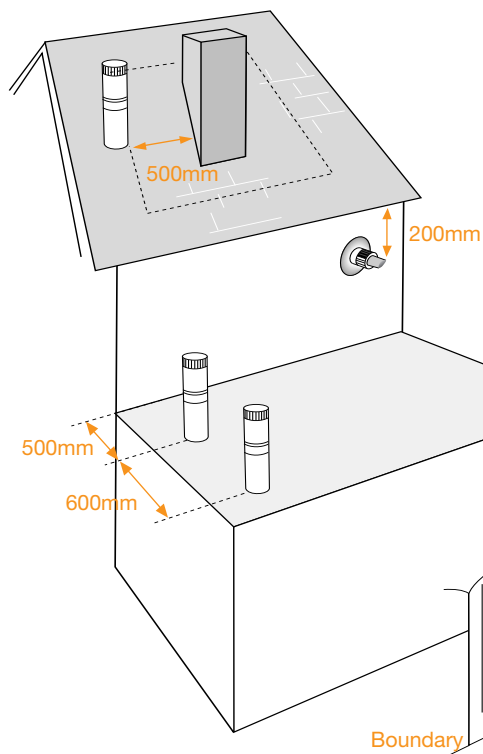
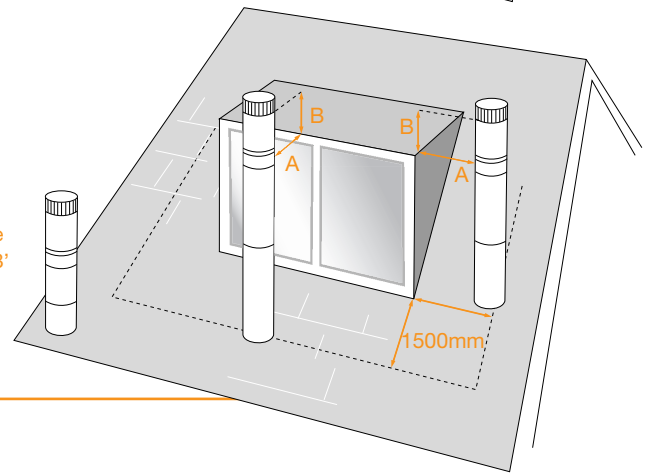

500mm clearance to any vertical structure on a roof. 600mm to another flue or 1500mm to an open flue.

200mm below eaves and 75mm below gutters, pipes and drains

600mm distance to a boundary, unless it will cause a nuisance. BS5440-1 recommends that care is taken when siting terminals in relation to boundaries.

60/100mm Flue components



1KWMA57W
60/100mm
1m Flue
Extension



041002X0
60/100mm
Vertical Adaptor



1KWMA64W
60/100mm
45° Bend



1KWUK356
60/100mm
Vertical Terminal



041051X0
60/100mm
90° Bend

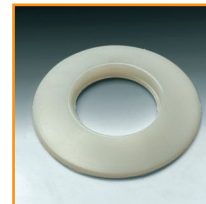

1KWMR11A
60/100mm
Wall Seal



1KWMR46A
100mm Flue
Support Bracket



1KWMA56W
60/100mm
Horizontal
Terminal

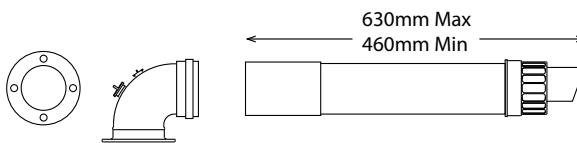

041049G0
60/100mm
Telescopic
Flue Kit

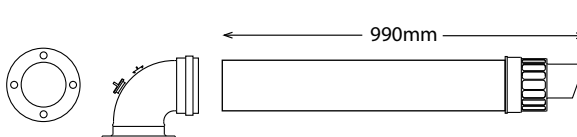

041025G0
60/100mm
Standard
Non-Telescopic
Flu Kit

80/125mm Flue components



1 KWMR43A
80/125mm
0.5m Flue
Extension



041006X0
80/125mm
Vertical Adapter



1 KWMA59W
80/125mm
1m Flue
Extension



010026X0
80/125mm
Vertical Roof
Terminal



1 KWMA72W
80/125mm
45° Bend

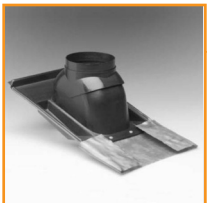

1 KWMA82U
Pitched
Roof Slate*



1 KWMA73W
80/125mm
90° Bend



1 KWMA81U
Flat Roof Slate*



1 KWMR49A
125mm Flue
Support Bracket



1 KWMR09A
125mm
Wall Flue Seal

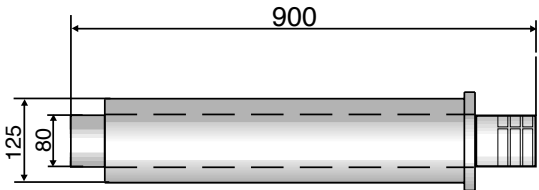

1 KWMA58W
80/125mm
Horizontal
Terminal

*Suitable for all Ferroli Vertical Roof Terminal Sets

80mm Flue components

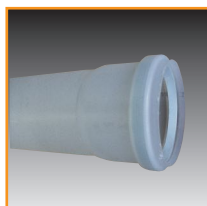

ZU00008115
80mm
0.5m Flue
Extension PP
(spigot/socket)

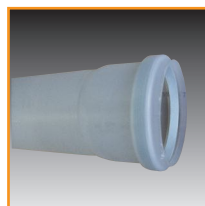

222953
80mm
2.0m Flue
Extension PP
(spigot/socket)

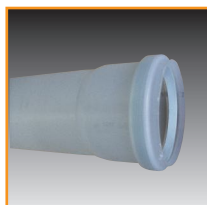

222952
80mm
1m Flue
Extension PP
(spigot/socket)

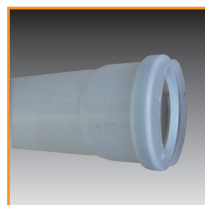

51608094
80mm
3.0m Flue
Extension PP
(spigot/socket)



222954
80mm
45° Bend

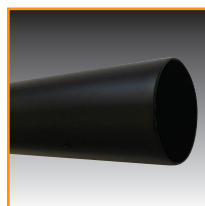

ZU00008127
80mm
Black Plastic
Terminal Section
(spigot/spigot)



222955
80mm
90° Bend



1KWMA86A
80mm
Horizontal Flue
Gas Terminal



010027X0
80mm Vertical
Roof Terminal



1KWMA85A
80mm
Horizontal Flue
Air Terminal



1KWMA84A
80mm Flue
Support Bracket



1KWMA84A
80mm Outer
Wall Flue Seal



041039X0
80mm
Vertical Adapter



Ferroli Limited

Lichfield Road, Branston Industrial Estate
Burton on Trent, Staffordshire, DE14 3HD

Sales t: 0843 479 4790 e: sales@ferroli.co.uk
Servicing t: 0843 479 0479 e: service@ferroli.co.uk
Technical t: 0843 479 0479 e: technical@ferroli.co.uk

Fax: 0843 479 0081

Calls to these numbers are charged at the national rate.

www.ferroli.co.uk

Whilst every effort is taken to ensure the accuracy of the information contained within the brochure, the details are offered in good faith and Ferroli Ltd. accepts no liability for matters arising as a result of errors and/or omissions.

The information in this brochure was correct at the time of printing, however specifications and designs may be changed owing to Ferroli's policy of continuous product research and development. The technical specifications in the product instruction manual supersedes and should always be referred to during installation and maintenance.

Reproduction of this publication, or any part, is not permitted without the written consent of Ferroli Ltd. Please contact our Marketing Communications via marketing@ferroli.co.uk for further information. The statutory rights of the consumer are not affected.

