

Standard Boiler

Owner and Installation Manual

Oil Heat Edition



This product meets the Energy Star[®] guidelines for efficiency

Manufactured By:
Energy Kinetics, Inc.
51 Molasses Hill Road
Lebanon, NJ 08833
(908) 735-2066
www.energykinetics.com



ASME certified by EKI.
Certificate plate is under the
jacket on the steel vessel.

- INSTALLER:** PLEASE HANG THIS INSTRUCTION MANUAL AND ASSESSORY INSTRUCTIONS VISIBLY NEXT TO THE BOILER USING THE SUPPLIED POUCH.
- CONSUMER:** PLEASE RETAIN THIS INSTRUCTION MANUAL AND ACCESSORY INSTRUCTIONS FOR FUTURE REFERENCE.

RECORD OF INSTALLATION

INSTALLER NAME: _____

INSTALLER ADDRESS: _____

INSTALLER CITY, STATE: _____

DATE INSTALLED: _____

NOTES: _____

INSTALLER NOTE:

ALL INSTALLATIONS MUST BE MADE IN ACCORDANCE WITH ALL STATE AND LOCAL CODES THAT MAY DIFFER FROM THIS MANUAL.

All installations must be made in accordance with all State and Local Codes, which may differ from this manual and in accordance with the following Codes, as applicable:

- N.F.P.A. No. 70: National Electrical Code
- A.N.S.I. / N.F.P.A. No. 31: Installation of Oil Burning Equipment
- A.N.S.I. / N.F.P.A. No. 211: Chimneys, Fireplaces, Vents and Solid Fuel Burning Appliances.

If this oil fired boiler is converted to gas fired by field mounting a listed gas conversion burner, then install in accordance with A.N.S.I. Z223.1/N.F.P.A. No. 54: National Fuel Gas Code

These codes are available from:
National Fire Protection Association
1 Batterymarch Park
Quincy, MA 02269-9101.

Table of Contents:

Page	Topic	Page	Topic
2	Record of Installation	12	Wiring and Controls
3	Table of Contents	12	Electrical Connection - Line Voltage
3	Please read this first	12	Line Voltage Wiring Diagram
4	SYSTEM 2000 Boiler - Principle of Operation	12	Low Voltage Wiring
5	Digital Energy Manager - Principle of Operation	13	Low Voltage Wiring Diagram
5	Receiving and Unpacking	13	Install Digital Manager
5	Location and Clearance	13	Digital Manager Option Switch Settings
6	Boiler Weight, Water Content, Air Inlet Sizes	14	Hydronic Control Settings
6	Combustion Air	14	Prepare for Start Up
7	Chimney Venting	14	Start Up Procedure
7	L-Vent Chimney	15	Oil Burner Operation
7	Sidewall Venting	16	Expanded Digital Manager Installation
8	Fuel Systems	16	Security System Interface Wiring
8	Oil Burner Settings	17	Digital Manager Operation Summary
8	Oil Burner Mounting	18	Complete Quick Check of the Digital Manager
9	General Assembly	19	Digital Manager Sensor Testing
9	Boiler Mounting	20	Troubleshooting with Digital Manager
10	Piping	20	Operation without the Digital Manager
10	Zone Control	20	Service Board Mode
10	Hot Water Storage Tank	21	Diagnostics with the Digital Manager
11	Heat Exchanger and Bypass	22	Annual Maintenance
11	Filling with Water, Venting, and Purging	23	Replacement Parts
11	Boiler Water Treatment	23	Amulet Replacement
11	Anti-Freeze	23	Combustion Chamber Replacement
11	Winterizing	24	Assembly Drawing
Inside Back Cover	Warranty Transfer Agreement	24	Parts List
		Back Cover	Limited Lifetime Warranty

Please Read This First...

Special Attention Flags

Please pay particular attention to the following flags when you see them throughout this manual.

- DANGER:** Notifies you of hazards that **WILL** cause severe personal injury, death or substantial property damage.
- WARNING:** Notifies you of hazards that **CAN** cause severe personal injury, death or substantial property damage.
- CAUTION:** Notifies you of hazards that **WILL or CAN** cause minor personal injury or property damage.
- NOTICE:** Notifies you of special instructions on installation, operation, or maintenance that are important, but not normally related to injury or property damage hazards.

WARNING: Do not store or use gasoline or other flammable vapors and liquids in the vicinity of this or any other combustion appliance.

CAUTION: DO NOT TAMPER WITH THE UNIT OR CONTROLS.

SYSTEM 2000® Standard Boiler

IMPORTANT MESSAGE TO HOMEOWNER: These instructions should be carefully read and kept for future reference to gain the best performance from your System 2000 boiler.

CONGRATULATIONS ON YOUR PURCHASE OF THE SYSTEM 2000 BOILER with its highly efficient low mass hydronic heat exchanger, the Energy Converter. It is the product of years of engineering and advanced design, which brings together in a single system all elements needed to provide efficient home heat and hot water. This operation and maintenance information has been prepared so that you may better understand and use your **Energy Kinetics System 2000 Boiler and Heating System**.

SYSTEM 2000 Boiler - Principle of Operation:

SYSTEM 2000 comprises a heat source, the energy converter, circulating water, a heavily insulated hot water storage tank and five (or more) zones controlled by an electronic control, the **Digital Manager**.

The Boiler sits cold until a thermostat calls for heat. The Digital Manager receives the call for heat and turns on the main circulator and burner. Water circulates within the boiler as it warms up to operating temperature. When ready, the zone valves open and deliver heat to the zones calling for heat. When the thermostats are satisfied, the Digital Manager turns off the burner and enters the energy recovery stage. The circulator and zone valve stay energized to deliver the heat remaining in the boiler to your home or to the domestic hot water storage tank.

When energy recovery is complete and the Boiler has been cooled off, the Digital Manager turns off the system and waits for another thermostat (or tank thermostat) to call for heat. **SYSTEM 2000** runs the burner only when you need heat and delivers that heat only where you need heat.

The System 2000 Energy Converter is the product of advanced thermal engineering. It is designed with two separate passageways, nearly 10 feet long, coiled around each other. Water travels along one passageway from your home toward the center of the unit and heated gases travel from the unit center toward the chimney. This is a "forced circulation counter-flow" design and it provides very efficient transfer of heat from the burning fuel to the circulating water. The superior insulation of the boiler minimizes heat losses to the surroundings, resulting in directing heat to your home in an efficient and quiet manner.

SYSTEM 2000 has an extremely high annual efficiency (over 99% of steady state) because it runs only when your home or hot water storage tank needs heat. Energy recovery is completed at the end of each heat or hot water call, virtually eliminating off cycle losses.

Your System 2000 holds a minimal quantity of water so it begins to supply heat in about 90 seconds. This rapid response means that your rooms can be heated quickly to temperature. Rapid response also means that domestic hot water is always available in the insulated storage tank and can be replaced almost as quickly as you use it. The System 2000 EK1 Boiler can heat water up to 120,000 BTU's per hour and the EK2 Boiler up to 240,000 BTU/hr.

A modern retention head oil burner fires into the center of System 2000 where a high temperature, light weight ceramic chamber provides ideal conditions for "near perfect" efficient, pollution-free combustion. Your System 2000 is tightly sealed so all products of combustion pass only to the chimney or sidewall vent.

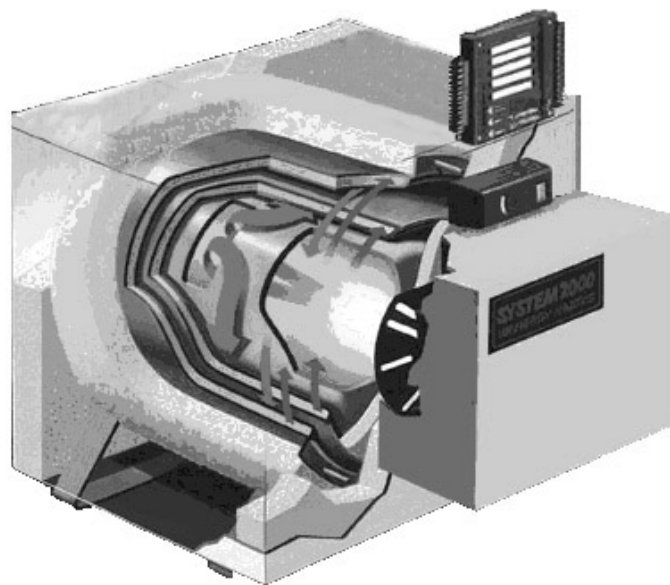

Digital Manager - Principle of Operation:

The left side of the Manager is the input side, which provides 24-volt power supply and connections for thermostats. The right side is the output side, which starts the burner, circulator, zone valves or zone circulators and the domestic hot water circulator. See photo of the Manager on the cover.

Lights on the Digital Manager indicate what is calling for heat (left side) and (right side) lights indicate active zone(s), burner operation and circulator operation. These function lights are an aid in servicing. The following is a typical cycle.

1. **SYSTEM WAITING FOR A CALL:** The boiler is turned off and sits cold, waiting until a call for heat. The red power light on the Manager is glowing.
2. **CALL FOR HEAT:** A room thermostat call or hot water call (aquastat) starts the cycle. The thermostat light on the left side will turn on for that zone.
3. **PRE-HEAT:** Output lights for the main circulator and burner turn on, the circulator starts, and the burner begins firing. The boiler water circulates through the energy converter via the bypass line, heating up the water.
4. **HEAT:** Once the boiler water has heated up to 140F (about 90 seconds), the Manager will turn on the zone output light on the right side. The zone valve will open and hot water will flow to the zone needing heat (for hot water, the zone output starts the hot water tank circulator). The burner runs as long as there is a thermostat calling and as long as heat is being delivered to the zone. The burner may shut off if the return temperature exceeds 170F/190F (RED burner light turns off) or if the high limit temperature is exceeded (RED burner light stays on, but the high limit aquastat shuts the burner off).
5. **ANOTHER CALL FOR HEAT:** If another zone calls for heat while the burner is already running and the return temperature is above 140F, the zone output will turn on, immediately supplying heat to the zone.
6. **MONITOR RETURN TEMPERATURE:** The Manager continually senses the return temperature and will turn off the zone outputs if the return temperature drops below 120° F (130° F if Option Switch #1 is ON). With the zone outputs closed, the boiler water will quickly reheat and once the return temperature reaches 140° F (150° F if Option Switch #1 is ON), then the Manager will reopen the zone valves.
7. **THERMOSTAT (or Aquastat) SATISFIED:** The thermostat light on the left side will go out. The burner light and the burner will then turn off.
8. **ENERGY RECOVERY:** The circulator and zone valve remain energized. The circulating water will remove the energy from the converter, sending the heat to the last zone that called. The energy recovery stage continues until the return temperature has dropped sufficiently or until maximum timing has been reached. The boiler is now sitting cold, waiting for the next call for heat. Maximum timing for heat recovery stage is usually set at twenty minutes for space heating zones and is fixed at five minutes for the Hot Water zone. (See *Digital Energy Manager Option Switch Settings*).

Receiving and Unpacking:

Inspect shipment upon receipt for external damage. When unpacking and uncrating, inspect each item for internal damage. Any damage found should immediately be reported to the freight carrier before installation. The receiver is responsible for following the claims procedure of the freight carrier. The freight carrier is responsible for taking prompt action on all claims. If freight cannot be inspected at the time of delivery, sign the bill of lading "Subject to Inspection" and inspect the shipment as soon as possible after receipt. Replacements for parts damaged in shipment are available upon receipt of a signed copy of a claim report (*concealed damage claims should be filed immediately against the freight carrier by the consignee*).

After unpacking, check each item against the packing list. Inspect it thoroughly for loose parts, instruction sheets and packing lists. Immediately report any missing items. It is wise to complete the installation before discarding packing material. Store all parts where they will not be damaged or lost during installation.

Location and Clearance:

DANGER: Provide clearance to combustible surfaces in accordance with all local and national codes. Follow National Fire Protection Association Bulletin NFPA Installation of Oil Burning Equipment and all applicable codes.

Installation Clearances	Clearance to Combustibles	Clearance for Service	
		Minimum	Recommended
FRONT	12"	12"	18"
EK1 BACK	6"	12"	18" OR MORE
EK2 BACK	6"	18"	24" OR MORE
RIGHT SIDE W/ FLUE	6"	12"	15"
LEFT SIDE/RIGHT W/OUT FLUE	6"	6"	15"
TOP	6"	6"	12"
FLUE CONNECTION	9"	6"	6"

Installations should utilize the Energy Kinetics prefabricated boiler stand to provide a solid, level, and smooth foundation for the boiler. Place the unit as near to the chimney or vent as possible allowing clearance for rear cleaning and service. If not using an Energy Kinetics supplied stand, provide a solid, level, and smooth foundation with clearance for door opening and service.

NOTICE: The stand must be **level** to allow for proper venting of air from the boiler. The System 2000 Boiler is manufactured with the front of the boiler *higher* than the back to assist in air removal.

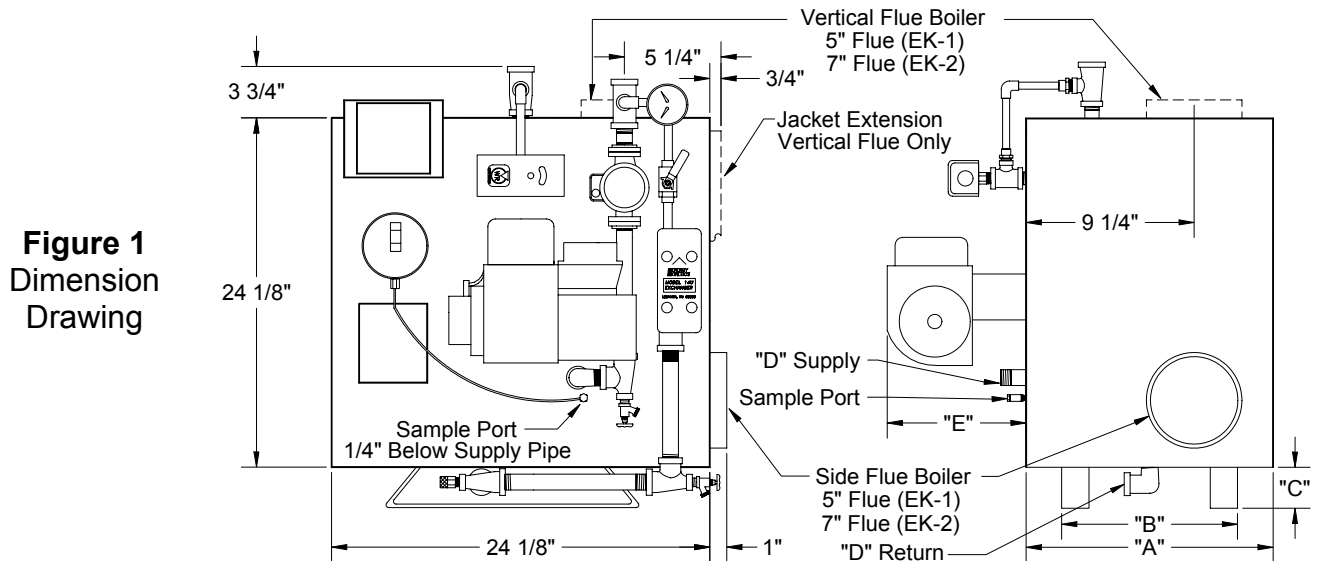

Clearances, Water Content, Weight, and Air Inlet Dimensions

Model	Water Content	Weight Lbs	Air Inlet Pipe Size	A	B	C	D	Burner	E	E With Air Box
EK1	2 ½ gal.	250	2"	17 ½"	13"	2 ½"	1"	Beckett	11"	13"
EK2	4 gal.	350	3"	24 ¾"	20 ¼"	3 ½"	1 ¼"	Carlin	14"	15 ½"
								Riello	13"	13"

COMBUSTION AIR

The System 2000 Boiler must be installed in an area where adequate fresh air is available to support combustion. The Frontier is provided with a sealed Air Box that can be piped to air outside the building. Piping of outside air directly to the boiler is highly recommended because it completely isolates the boiler from the home environment, as well as greatly reducing operating noise from the boiler.

Boiler with outside air piping:

In modern houses with tight construction, the connection of the Air Box to an outside air source to provide combustion air is highly recommended. The outside air source must be located high enough above grade to be at least 12" above expected snow accumulation.

WARNING: For systems with sidewall venting, combustion air piping from outside the building is required. The Energy Kinetics sidewall vent kit contains specific instructions for installation that must be followed. Combustion air may be supplied through PVC pipe. For EK1 use, 2" pipe up to 20 feet in length with up to (5) 90-degree elbows. For EK2 use, 3" pipe up to 20 feet in length with up to (5) 90-degree elbows. A total equivalent length of 45 feet is allowed. Each 90 degree elbow is the equivalent of 5 feet of straight pipe. For example, if three 90 degree elbows are used, then the length of pipe run may increase to 35 feet. For longer runs up to 40 feet with up to five 90 degree elbows, immediately increase pipe size by 1", to 3" for EK1 and 4" for EK2. An unglued or Tek-screw joint allows the door to swing down when the air inlet pipe is disconnected.

Boiler without outside air piping:

WARNING: The confined space shall be provided with two permanent openings, one near the top of the enclosure and one near the bottom. Each opening shall have a free area of not less than one square inch per 1,000 BTU per hour of the total input rating of all appliances in the enclosure, freely communicating with interior areas having adequate infiltration from the outside.

WARNING: Modern buildings of tight construction, as well as the operation of attic and exhaust fans, kitchen ventilation systems, clothes dryers or fireplaces may create conditions of unsatisfactory combustion or venting. Provisions must be made to use combustion air that communicates with a well-ventilated attic or with the outdoors (such as using a louver or grate). The opening should have a free area of not less than one (1) square inch per 4,000 BTU per hour of the total input rating.

CHIMNEY VENTING:

WARNING: Masonry chimneys must have a tile or metal liner. The liner must:

- 1) Extend above the masonry.
- 2) Have an insulating air gap, isolating the liner from the chimney, allowing for rapid heat-up and draft establishment.
- 3) Be sealed at each joint to prevent air infiltration and damage from condensation.

NOTICE: Inspect Chimney and Chimney base after initial three months of heating season.

The installation of a chimney cap is recommended. The base of the chimney must always have a drop leg below the flue connector to allow scale and condensation to accumulate without blocking the flue pipe.

CAUTION: If drop leg is in excess of 12 inches deep, backfill with loose gravel or sand to obtain a maximum of 12-inch depth. All clean out doors must be sealed to prevent cold air entry into chimney.

In retrofit installations, have chimney thoroughly cleaned. Carefully inspect chimney, base of chimney, and liner prior to installation of System 2000 Boiler.

CAUTION: If liner is not sound, or if existing tile liner fails to contain intermittent condensation, or if excessive debris is found at the base of the chimney, then it is recommended to install a properly sized metal liner approved for use with oil heat appliances.

The metal liner diameter and length should be as recommended by the metal liner manufacturer. Corrugated metal liners should be at least 5" diameter for EK1 and 6" diameter for EK2. Connection of a flexible metal liner directly to the flue collar of the boiler is an acceptable connection method and is recommended. Energy Kinetics does not recommend use of a base tee when a corrugated metal liner is installed. Alternatively, a flexible metal vent connector may be used between the flue collar of the boiler and a flexible metal liner. Call Energy Kinetics for details on metal liners.

Chimney connectors should be positioned to create the shortest possible run of flue pipe to the chimney. The overall horizontal length of flue piping should not exceed 15 feet. Long runs or low firing rates may require insulated flue pipe such as L-Vent or All-Fuels to keep the temperature at base of chimney adequate for draft and to prevent corrosion of piping and connectors.

Because the System 2000 boiler uses a power burner, the flue pipe may experience some positive pressure on start up. Energy Kinetics recommends that all pipe joints be sealed with high temperature silicone sealant to ensure passage of all combustion products to the chimney.

Normally, pitch horizontal flue pipe up toward chimney approximately ¼" per foot. For existing installations, it is permissible for the flue connection of the boiler to be higher than the chimney thimble, provided adequate draft is established.

If a minimum of -0.02" w.c. draft overfire is not present after sufficient burner run time to heat up the chimney, there is a problem that will need to be corrected. Call Energy Kinetics for help resolving draft problems. Under normal circumstances, there is **NO** need for a DRAFT REGULATOR and one should not be installed. Call Energy Kinetics with questions about flue pipe sizing.

WARNING: No solid fuel appliance or fireplace should be installed in a flue common with this heating appliance. The flue gas exit of the venting system must be at least three (3) feet above the point at which it passes through the roof and at least two (2) feet higher than any portion of a building within 10 feet horizontally of its location.

L-Vent Chimney:

SYSTEM 2000 Boilers typically have flue gas temperatures between 350F and 450F during normal operation. Due to the low flue gas temperatures, L-Vent chimney pipe is suitable for use with SYSTEM 2000 Boilers. L-Vent chimney pipe may require smaller chase dimensions than other chimney pipe materials and should be considered for new installations with SYSTEM 2000 Boilers. Call Energy Kinetics for help locating sources of L-Vent.

1. L-Vent must be U.L. Listed to U.L. 641.
2. L-Vent to be installed in accordance with the vent manufacturer's instructions.
3. System 2000 and L-Vent must be installed in strict compliance with all State and Local Codes and with the regulations of the authorities having jurisdiction, which may differ from and which take precedence over these instructions or the vent manufacturer's instructions.

Sidewall Venting:

1. System 2000 Boilers may be installed with Energy Kinetics' sidewall vent kit in accordance with kit instructions.
2. **WARNING:** Sidewall vent systems **must** have outside air connected to the air box **and** both air box air intake and vent hood **must** be located on the same side of the structure.
3. **NOTICE:** The sidewall vent inducer should be located above the boiler flue outlet, preferably a minimum of four feet vertical distance, which will provide some natural draft to the boiler (and cooling of the burner) in case of a power failure.
4. When installing a sidewall venting system from another manufacturer, ensure that the manufacturer's instructions are followed. Vent manufacturer should confirm that the equipment is suitable for use with System 2000.
5. Set the draft over fire through the puff switch opening between -.10" to -.12" w.c. with the burner running, after allowing time for sufficient warm-up. Check/adjust CO₂. Re-check the draft over fire and adjust draft if necessary.
6. To provide power to the sidewall vent, install the plug-in relay supplied with the sidewall vent kit into the junction box relay board and set the Digital Manager Option Switch #2 to the "ON" (down) position. This enables the "Inducer" light and allows the Digital Manager to control the inducer. Refer to Digital Manager section for option switch settings and inducer timing details.

Fuel System:

NOTICE: Inspect and if needed, replace oil lines according to local codes. Oil lines must be absolutely airtight. Use only flared joints on all copper tubing and use thread sealant suitable for oil on all iron pipe threaded joints. Do not use teflon tape on fuel system joints. Check all joints and connections for leaks after installation. A high quality fuel filter should be installed in the fuel line. Energy Kinetics' "Smart Filter" or equivalent 10-micron filter is recommended. When changing the Smart Filter, be sure to *lubricate cartridge gasket with motor oil*, not heating oil.

All piping systems should conform with pump manufacturer's specifications that are attached to each new pump. The burner is capable of burning No. 1 or No. 2 heating oil. A fusible link shutoff valve should be installed on the supply line.

NOTICE: A two-stage pump is required if lift from oil tank exceeds approximately ten (10) feet. Follow instructions provided by pump manufacturer on single and two pipe connections for bypass plug usage and other specific installation requirements.

Oil Burner Settings:

EK1 Boilers are shipped from the factory preset for 0.85 GPH firing rate and EK2 Boilers are shipped from the factory preset for 1.40 GPH firing rate. The SYSTEM 2000 Boiler can be fired over a range of firing rates to suit the needs of the application. The following table lists approximate settings for oil burners based on testing performed at Energy Kinetics.

CAUTION: Final settings for each burner and firing rate for a particular installation **must** be determined by using combustion test equipment and following the instructions given under "Start Up Procedure".

CAUTION: Because the energy converter removes heat from the combustion flue gas so efficiently, low firing rates may not provide high enough flue gas temperature for proper draft in a chimney. The Columns labeled 'Chimney' and 'Sidewall' show the suitability of the firing rate for a particular combination.

Model	Input GPH	Chimney	Sidewall Vent	Nozzle@ Pump Pressure	Beckett AFG ¹ Delavan 70°A		Carlin 99FRD Single Slot Air band Delavan 60°A		Riello 40F5 Delavan 60°B	
					Air band: 0	Shutter: 4	Head: 1.0	Air: 25	Head: 1.0	Air: 2.25
EK1	.68	N	Y	.60@130 psi	Air band: 0	Shutter: 4	Head: 1.0	Air: 25	Not Recommended	
	.74	N	Y	.65@130 psi	Air band: 0	Shutter: 5.5	Head: 1.0	Air: 35	Head: 1.0	Air: 2.25
	.85*	Y	Y	.75@130 psi	Air band: 0	Shutter: 7	Head: 1.5	Air: 45	Head: 1.5	Air: 2.5
	1.0	Y	Y	.85@136 psi	Air band: 1	Shutter: 8	Head: 2.5	Air: 60	Head: 2.0	Air: 2.75

¹ the Beckett AFG at 0.68 gph firing rate can be retrofitted with the Beckett Low Firing Rate Baffle. If used, set air band: 0, shutter: 8.5.

Model	Input GPH	Chimney	Sidewall Vent	Nozzle@ Pump Pressure	Beckett AFG	Carlin 99FRD Dual Slot Air band Delavan 60°B		Riello 40F5 Delavan 60°A	
						Head: 2.5	Air: 55	Head: 3.0	Air: 3.5
EK2	1.20	N	Y	1.00@145 psi	Not Recommended	Head: 2.5	Air: 55	Head: 3.0	Air: 3.5
	1.40*	Y	Y	1.25@125 psi	Not Recommended	Head: 3.0	Air: 55	Head: 3.5	Air: 5.5
	1.60	Y	Y	1.35@140 psi	Not Recommended	Head: 4.0	Air: 60	Not Recommended	
	1.75	Y	N	1.50@135 psi	Not Recommended	Head: 4.5	Air: 80	Not Recommended	

* Factory Setting

Oil Burner Mounting:

SYSTEM 2000 Boilers are shipped from the factory with the oil burner pre-mounted. The burner flanges are designed to insert the burner head 2-3/8" into the boiler. Energy Kinetics installs a ceramic sleeve, (the amulet), to protect the burner head from the heat of combustion, and then seals the air tube flange joint with a high-grade retort cement. **NOTICE:** Oil burners for field installation or for field replacement should be installed according to burner manufacturer instructions, according to installation instructions below, and with consultation with Energy Kinetics for any special considerations or adjustments.

Follow these instructions for field installation of Energy Kinetics supplied burners. Start by checking nozzle and electrode position per manufacturer's specifications prior to assembly to unit. Test fit the amulet by inserting the amulet into the boiler opening. If the amulet doesn't easily slide into the boiler, then gently sand the outside diameter of the amulet until it will fit into the boiler opening. Test fit the amulet onto the burner head. Note that the amulet designed for the Beckett AFG burner has interior slots to accept the screws on the sides of the head. The amulet for the Beckett AFG has a small drain hole in the front face, that must be mounted at the bottom (at 6 o'clock position). The amulet for the Carlin and Riello

burners have smooth interiors. If the amulet is a tight fit on the burner head, then slightly moisten inside the amulet with water.

Place a 3/8" bead of retort cement onto the burner head at the flange to air tube joint, and slide the (moistened) amulet over the burner head and against the flange. Ensure proper seating of the amulet by pressing the amulet onto the burner with a flat object. Leave the excess retort cement at the amulet to flange joint and the cement will provide an airtight seal of the air tube flange to the boiler face.

The Beckett amulet has an inside edge that will cover the edge of the Beckett burner head. The Beckett retention head air slots must not be blocked or obstructed by the amulet. If needed, trim a 45 degree chamfer on the inside of the amulet using a sharp utility knife and maintain a 1/8" clearance to retention head air slots. The Carlin and Riello amulets do not have an edge and when fully seated the amulets will be flush with the front of the Carlin or Riello burner heads. If needed, trim the front edge of the amulet to be flush with the front of the burner head.

Once the amulet has been seated and trimmed, then install the burner into the boiler by carefully inserting the air tube with amulet into the boiler opening while aligning the burner flange holes with the boiler studs. Install flat washers and nuts onto the boiler studs and tighten all nuts evenly.

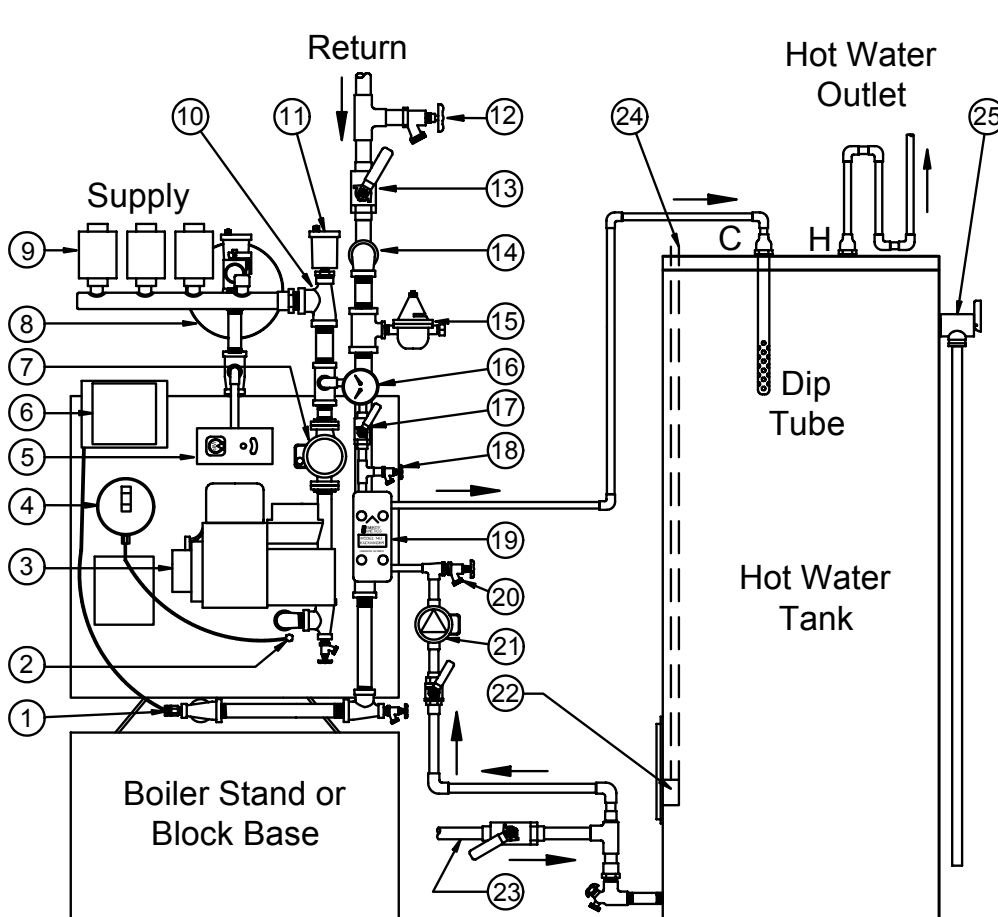

General Assembly:

Assembly of various packaged units is illustrated throughout this manual. The use of non-Energy Kinetics supplied pump, controls and accessories should follow good practices. The diagrams and locations presented in the manual are recommended.

Boiler Mounting:

BOILER MOUNTING on STANDARD BASE, FIGURE 2A: Follow base assembly instructions packed in the base carton, or mount on solid, level blocks.

BOILER PITCH: The System 2000 Boiler pressure vessel is manufactured with the front 1/2 to 1 bubble higher to allow for proper air removal. This pitch is carefully set at the factory when the boiler is built. Be sure to **level the stand** prior to mounting the boiler on the stand. When the stand is level, the pitch is correct and the front of the boiler will be higher than the back. The EK1 System 2000 Boiler is pitched 1/4" and the EK2 System 2000 Boiler is pitched 7/16".

Figure 2A

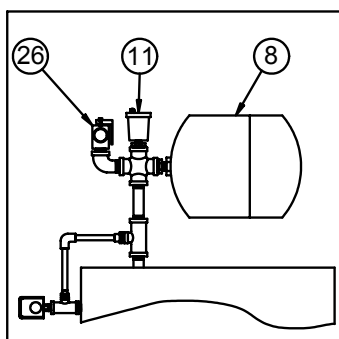

**Side View
(Top of Boiler)**

- | | |
|------------------------------------|--------------------------------------|
| 1. Digital Temperature Sensor | 14. Return 1" EK-1 / 1-1/4" EK2 |
| 2. Combustion Test Port | 15. Boiler Feeder (Premier Pkg Only) |
| 3. Burner | 16. Tridicator Gauge |
| 4. Puff Switch | 17. Bypass Valve |
| 5. High Limit Aquastat | 18. Boiler Side Backflush (Optional) |
| 6. Digital Manager | 19. Plate Heat Exchanger |
| 7. Main Circulator | 20. Domestic Side Backflush Valve |
| 8. Expansion Tank (Not Supplied) | 21. Smart Pump w/Internal Flow Check |
| 9. Zone Valves | 22. Tank thermostat (Under Cover) |
| 10. Supply 1" EK-1 / 1-1/4" EK2 | 23. Cold Water Supply |
| 11. Air Vent (on boiler supply) | 24. Aquastat Leads |
| 12. Purge Valve (Premier Pkg Only) | 25. Hot Water T&P Relief Valve |
| 13. Ball Valve (Premier Pkg Only) | 26. Boiler Relief Valve |

Figure 2B
Typical Flow
Schematic

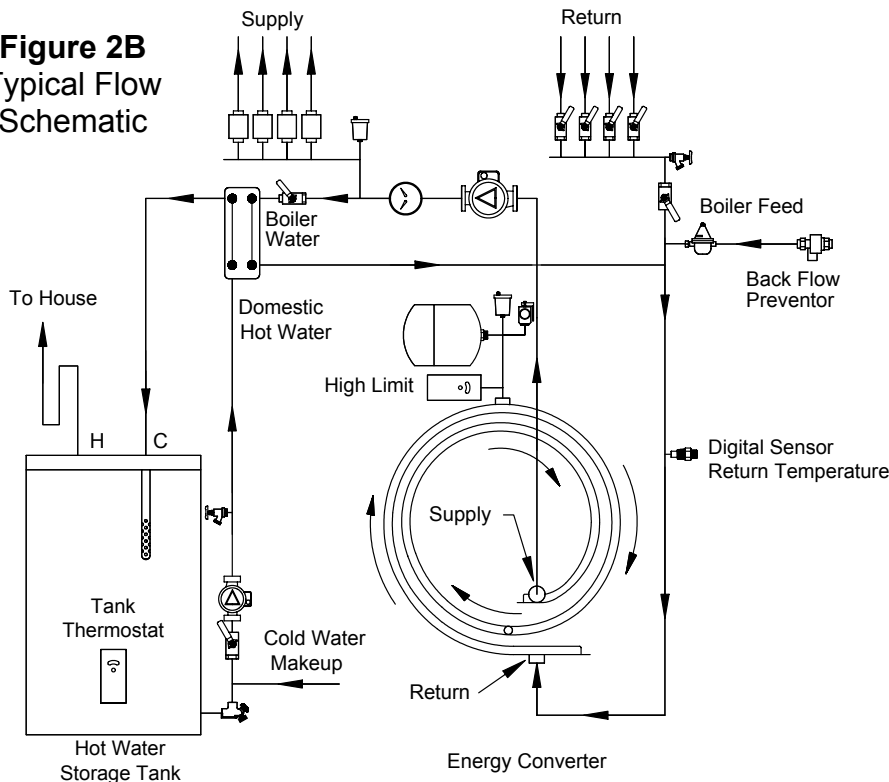

Piping:
All piping and accessory connections should follow good practice using approved joint sealants. **Figure 2B** indicates general system piping arrangement and options.
Figure 2B indicates a typical flow schematic for boiler water and domestic water. Each system will vary according to job location.
Call Energy Kinetics to obtain piping and wiring instructions for alternate applications, such as radiant heating, swimming pool heating, multiple boilers, injection loops, etc.

Zone Control:

Zone Control By Valve: The SYSTEM 2000 Boiler is designed to provide multi-zone control of the heating system and domestic hot water. Energy Kinetics recommends and supplies two wire, full port, 24 volt zone valves for control of each heating zone. A system with a single heating zone still requires a zone valve to provide control for preheat of unit and to maintain minimum temperature during operation.

Zone Control By Circulator: Zone control by circulators requires a flow valve, circulator and 24-volt relay (fan type such as Honeywell R8225B) for each zone. The main circulator, domestic heat exchanger and bypass line are still used in these cases. **NOTICE:** An additional tee must be installed into the supply **on the inlet side** of the main circulator. This tee is the supply for circulators with returns for these zones into normal return location. Call Energy Kinetics and request "Zoning with Circulators" diagram.

Zone Purging: Valves to isolate and purge individual zones should be installed according to good piping practices.

Expansion Tank Sizing: The type and size of expansion tank depends on the total system water volume. The EK1 System 2000 Boiler contains 2-1/2 gallons of water and the EK2 System 2000 Boiler contains 4 gallons of water.

NOTICE: Sizing must consider **cold start** and **hot operation** due to system concepts of energy recovery and rapid heat up.

Hot Water Storage Tank:

Figure 2A indicates a typical arrangement of the domestic hot water system. The tank may be located adjacent to or in any other convenient location. If greater than 10 feet away, use 3/4" lines and an air vent on a high return. Insulation of water lines between the storage tank and Energy Converter and on the hot water supply to the house is recommended for best fuel efficiency. Energy Kinetics supplied storage tanks come complete with high-density foam insulation, a properly located aquastat, a temperature/pressure relief valve, and a specially designed dip tube.

DANGER:

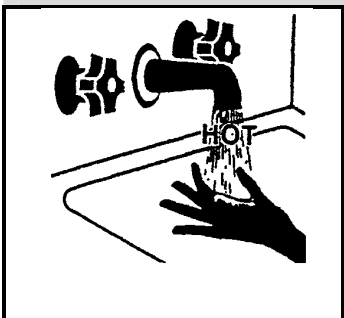

Hot water temperature over 125F can cause severe burns instantly or death by scalding. Children, disabled, and elderly are at the highest risk of being scalded. Test water temperature before bathing or showering. Temperature limiting, anti-scald mixing valves are available and recommended.

Hot water storage tank thermostat does not limit the maximum delivered water temperature. The plate heat exchanger will always provide water that is hotter than 125F into the hot water storage tank where it will mix with the water in the storage tank. The hot water storage tank can deliver water hotter than 125F depending on the degree of tank temperature stratification. If codes place limits on maximum delivered water temperature, an anti-scald mixing valve **MUST** be installed on hot water tank outlet.

Heat Exchanger and Bypass:

NOTICE: The heat exchanger is piped at the factory and its location and orientation should not be altered without consulting with Energy Kinetics. The heat exchanger is mounted in the bypass line at the boiler with a ball valve. Systems without a heat exchanger are piped at the factory with the bypass line and ball valve. The bypass valve must be at least partially open for the boiler to operate properly.

Pipe domestic water to the connections as marked on the plate heat exchanger. When ordering a replacement, order the part number shown in the Assembly Drawing.

WARNING:

The single wall plate heat exchanger complies with 1990 N.S.P.C. provided that both of the following are true:

- A) The boiler water (including additives) is practically non-toxic, having a toxicity rating or class of 1 as listed in Clinical Toxicology of Commercial Products, 5th Edition.
- B) The pressure of the boiler water is limited to a max of 30 psig by an approved safety or relief valve.

Filling With Water, Venting, and Purging:

When piping is completed and all accessories installed the Converter and piping should be filled with water. The Converter purges itself of air when properly installed. **NOTICE: AIR VENT CAP MUST REMAIN OPEN.** Vent cap should be removed and kept in a safe location. Each zone should be purged until a steady stream of water without air passes out of purge hose. Vent all radiation.

NOTICE: DO NOT START BURNER UNTIL CONVERTER AND SYSTEM ARE FULL OF WATER. Fill to normal cold system pressure, 10 to 12 psi on pressure gauge. Before placing system in operation, carefully check for leaks throughout system. Tighten pipe joints, circulator flanges, check gaskets, etc., as needed.

Boiler Water Treatment:

Addition of boiler water treatment is recommended to reduce lime buildup inside the boiler. Energy Kinetics recommends addition of one quart of 8-Way Boiler Treatment per 30 gallons system water. 8-Way Boiler Treatment is recommended to treat water up to medium hardness. Call Energy Kinetics for more details about boiler water treatment and about hard water conditions.

Anti-Freeze:

Only non-toxic antifreeze (such as Propylene Glycol) should be used if adding anti-freeze to a system that produces domestic hot water. Hard water should not be used in combination with generic antifreeze. Energy Kinetics supplies a quality inhibited Propylene Glycol anti-freeze with orange dye and an antifoam agent. 8-Way Boiler Treatment can be added to Energy Kinetics anti-freeze and is recommended in areas of medium water hardness. **NOTICE: Thoroughly clean system prior to adding antifreeze.** TSP is recommended for removing flux and other oil based compounds. Once system has been cleaned and flushed, then add antifreeze to obtain approximately a 30% by volume mixture of antifreeze in water. Call Energy Kinetics for assistance in calculating how much anti-freeze to add to system.

Winterizing:

NOTICE: If the SYSTEM 2000 Boiler may be exposed to freezing temperatures, such as a vacation home shut down for the winter, then anti-freeze should be added. When a home is winterized by draining all domestic water piping, then the SYSTEM 2000 Boiler must be protected. It is not recommended to drain the SYSTEM 2000 Boiler, because introducing air into the boiler can cause rusting inside the boiler shell and also because the Energy Converter has a spiral water passage that cannot be completely drained of water. When draining the domestic water piping system, be sure to drain the domestic side of the plate heat exchanger. If the hydronic system will not be drained, then add enough anti-freeze to protect the entire hydronic system including the boiler, piping, radiation, circulators, etc. If the hydronic system will be drained, then add shut off valves to isolate the boiler and add anti-freeze to the boiler only, as follows. Drain water from the boiler and then add anti-freeze to the boiler. Refill boiler with water and run boiler circulator through the bypass to distribute antifreeze within boiler. Propylene Glycol in water will provide the following freeze protection: 30% down to +8F, 40% to -8F, and 50% to -27F. Energy Kinetics recommends using 30% anti-freeze to obtain the best boiler performance. Use over 30% anti-freeze only if lower temperature freeze protection is mandatory.

CAUTION: Always keep the fuel supply valve shut off if the burner is shut down for an extended period of time.

Wiring and Controls:

The System 2000 Boiler Heating System is furnished with controls and basic accessories as illustrated and described in this manual. Control, burner and accessory instruction sheets and system wiring diagrams should be attached to this manual for future reference. **DANGER:** All wiring must comply with the NEC and any local codes.

Electrical Connection - Line Voltage:

POWER SUPPLY: 120 VOLT 60 HZ, 7.5 Amperes

DANGER: Make All Connections with Power Off at Main Circuit Box

Figures 3A and 3B: Connect power from a separate 15 AMP fused circuit. Install 3rd wire grounding for proper bond between all electrical accessories. The system switch is included so power can be shut off at the unit for servicing.

Pigtails are provided for the line voltage power connection. Connect black pigtail to hot, white pigtail to neutral, and the green pigtail to ground. **WARNING:** The junction box is wired at the factory with the service outlet always powered, even with the System Emergency Switch turned off. To have the service outlet controlled by the System Emergency Switch, move the service outlet black lead to top lug of system switch. A low water cut-off may be field installed if required by local codes and is available from Energy Kinetics.

Line Voltage Wiring Diagram:

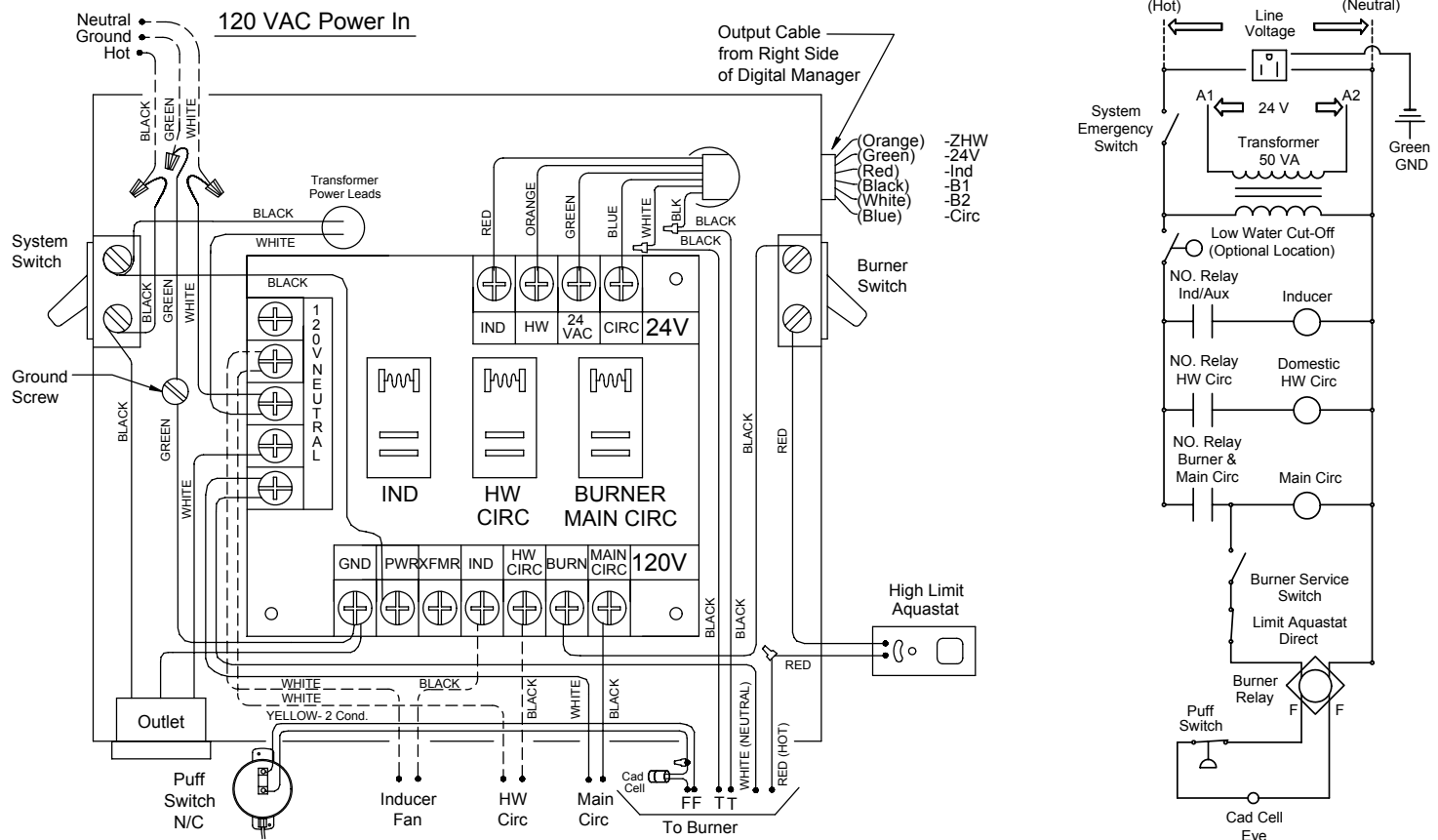

Figures 3A & 3B

Low Voltage Wiring:

DIGITAL MANAGER OPERATES ONLY ON 24 VOLT 60 HZ POWER

WARNING: Make All Connections with Power Off at Main Circuit Box

A typical low voltage wiring diagram for the Digital Energy Manager is shown in **Figure 4A**. Thermostats must be located on inside walls away from cold drafts, windows or heat from fireplaces, appliances or sunlight. Set thermostat heat anticipators to 0.1 amps (or "gas" if gas/electric option). Call Energy Kinetics to request alternate low voltage wiring diagrams to handle special situations such as air handler wiring, heat pump wiring, isolation relays for thermostats, and isolation relays for heat motors or circulators, etc.

The single 24-volt/50VA transformer is suitable for the Digital Manager and five zone outputs (zone valves or relays).

NOTICE: Additional load such as extra valves may require greater transformer capacity. To add transformers, wire in parallel as follows: wire terminal "A" on one transformer to "A" on the other. Repeat with other low voltage terminal "B". Be sure to verify 24VAC output from all transformers.

FIELD WIRING - - - - -
USE COPPER CONDUCTORS ONLY

The Digital Energy Manager is designed for hot water and up to four (4) heating zones. Use Energy Kinetics supplied zone valves with two wire connections. For more than four heating zones, use Energy Kinetics expanded 10 or 15 zone Digital Energy Manager, or call Energy Kinetics for alternatives.

Low Voltage Wiring Diagram:

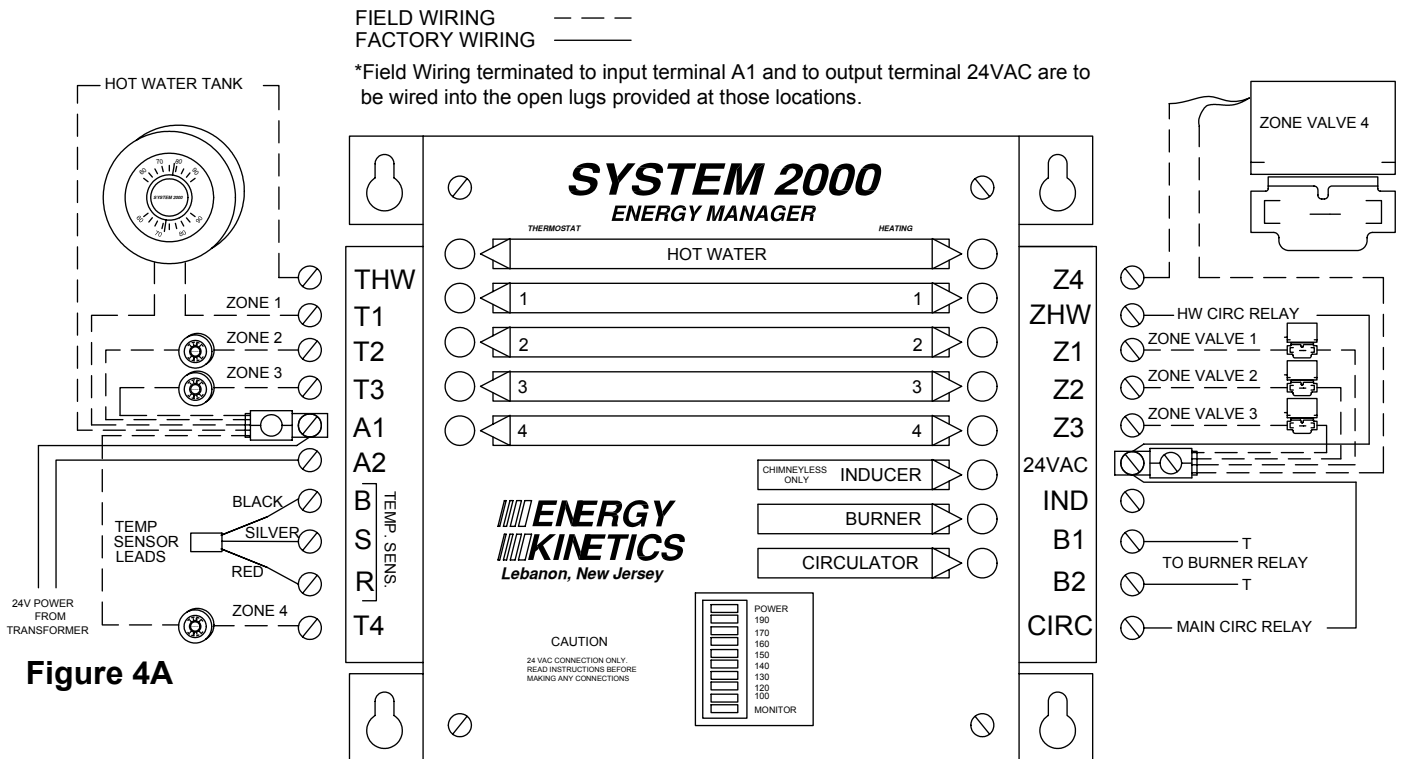

Figure 4A

Install Digital Manager:

The Digital Energy Manager is shipped in its own protective shipping box. **NOTICE:** The option switches can be set very easily before the Manager is installed. Locate the pre-wired quick connectors fastened to the front of the junction box by two cable ties. Cut the two cable ties and discard. Fasten the Digital Manager to the junction box with the four corner screws. Slide the two quick connectors onto the Digital Manager. Label each zone on the manager, using the adhesive on labels supplied.

Digital Manager Option Switch Settings

Switches are located on bottom of Digital Energy Manager

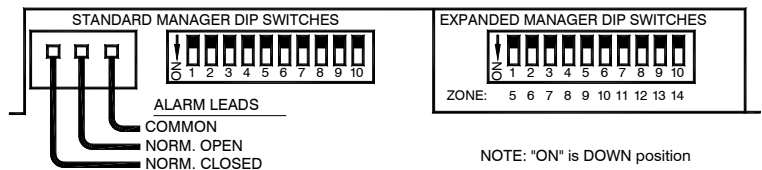

Figure 4B

Option Switch	Description	Function	
		ON = DOWN	OFF = UP
1	Low Return Temp.	ON = 130° / 150° F. (Gas)	OFF = 120° / 140° F. (Oil)
2	Inducer/Chimney	ON = Inducer Venting	OFF = Chimney Venting
3	Inducer Purge Temp.	ON = stop purge when Boiler Return Temp cools down to 120° F	OFF = stop purge when Boiler Return Temp cools down to 140° F (See Switch # 4)
4	Inducer Purge Time	ON = 3 minutes minimum After purge time, purge controlled by return temperature. (See Switch # 3)	OFF = 5 minutes minimum
5	Zone 1 Purge Time	ON = max 5 minutes energy recovery	OFF = max 20 minutes energy recovery
6	Zone 2 Purge Time	ON = max 5 minutes energy recovery	OFF = max 20 minutes energy recovery
7	Zone 3 Purge Time	ON = max 5 minutes energy recovery	OFF = max 20 minutes energy recovery
8	Zone 4 Purge Time	ON = max 5 minutes energy recovery	OFF = max 20 minutes energy recovery
9	High Return Temp.	ON = 190° / 175° F.	OFF = 170° / 155° F. (Normal)
10	Hot Water Priority	ON = Priority	OFF = No Priority

For a typical oil fired boiler with a sound chimney, supplying domestic hot water and properly sized heat zones, all option switch settings will be "OFF". Turn switch 1 on to provide increased condensing protection (recommended for gas fired boilers). For sidewall vent applications, turn switch 2 on and then usually leave switches 3 and 4 off.

Switches 5 through 8 are usually off, but can be turned on if the heat zone tends to overheat during energy recovery. Switch 9 is usually off, but can be turned on to supply higher temperature water to under-radiated heating zones or during very cold weather. Switch 10 is usually off, but when turned on the Manager will close heat zones 1 through 4 during a hot water call for up to 25 minutes.

Hydronic Control Settings

Control	Model No.	Normal Setting
HIGH LIMIT AQUASTAT <i>(Located front and center of boiler)</i>	White Rodgers Model 1145-42 Energy Kinetics PN: 10-0415	215° Maximum 10° Differential: 215°– 205° F.
HOT WATER TANK THERMOSTAT <i>(Located on domestic storage tank)</i>	Energy Kinetics PN: 10-0414	120° Normal <i>(To suit individual installation)</i>

Prepare For Start Up:

DANGER: MAKE CERTAIN THE FOLLOWING REQUIREMENTS HAVE BEEN SATISFIED BEFORE START UP:

1. The boiler and piping are completely filled with water.
2. Re-check wiring to ensure that it is correct and in accordance with appropriate wiring diagrams and codes.
3. Verify that proper nozzle is used and installed correctly.
4. Verify electrode settings.
5. Verify the burner settings for air band position and head position *(See "Oil Burner Settings" Table)*.
6. Oil supply is connected to burner. Oil supply lines and shut-off valves are open.
7. Fuel pump and fuel lines are purged.
8. Verify operating oil pressure at gauge port.
9. Adjust bypass valve on boiler side to heat exchanger ½ way open. *(See #4 under "Oil Burner Operation")*
10. Flue pipe properly connected from unit to chimney. All joints are secured and sealed.
11. Combustion air supply is available and sufficient. *(See "Combustion Air")*
12. Adjust valve in domestic hot water circuit under circulator approximately ¾ of the way open.
13. Punch a ¼" sampling hole in flue pipe as near to unit as possible in flue outlet and loosen 1/8" brass plug in front jacket (under the burner) for use as the overfire sampling location.
14. **Caution:** All covers, enclosures, and guards must be maintained in place at all times, except during maintenance and servicing.
15. **Caution:** Do not start burner unless the rear cover is closed and the nuts have been properly tightened

Start Up Procedure:

1. Turn on system supply switch and burner supply switch. The Digital Manager lights should come on briefly, the circulator relay should close briefly, and then the Digital Manager should only show one red light next to 'power'.
2. The hot water tank thermostat should call for heat, if not, adjust a thermostat to call for heat. Burner and main circulator should come on at the same time. If not, check primary control and reset it if necessary.
3. Check for burner light off. On an oil supply system with one pipe, it will be necessary to bleed air from fuel pump. On a two pipe system, several starts may be required to clear air from fuel pump, or bleed air from pump.
4. On light off, water temperature and chimney temperature will start to rise. A slight odor is common on initial light off as combustion chamber and converter surfaces warm for the first time.
5. **NOTICE:** Perform smoke test immediately after light off. Smoke test should show yellow after initial one minute of operation due to the combustion chamber sizing heating up. If the smoke test shows dark gray or black after one minute of operation, shut off boiler immediately and repeat "Prepare for Start Up" checklist.
6. As Unit reaches temperature, Digital Manager "Heating" light will signal heat distribution to zone(s) calling for heat. (On first start up, this will usually be the hot water storage tank zone.) Once boiler water temperature reaches 160° – 180° F., adjust hot water temperature flowing to storage tank. With hot water flowing fully from a domestic faucet, adjust valve under domestic circulator pump so water temperature going into tank is approximately 140° F. (Hand can be held on pipe just briefly.) Water must be flowing fully from a household hot water tap to accurately adjust flow and temperature entering tank.
7. Allow system to run about 15 minutes before testing and recording burner operation. *(See "Oil Burner Operation")*
8. **Caution:** Do not attempt to start the burner when excess oil has accumulated, when the unit is full of vapor, or when the combustion chamber is very hot.

Oil Burner Operation:

NOTICE: For reliable operation, set Air-Fuel mixture conservatively based on installation conditions. CO₂/O₂ reading should be taken through 1/4" test port in the puff switch opening just underneath burner. Use 1/4" steel or copper sample tube and extend at least eight (8) inches into front cover to obtain accurate readings. Smoke test and stack temperature should be taken at flue outlet.

NOTICE: For accurate efficiency calculations, measure flue gas temperature in flue pipe. Flue box and over fire temperatures may be higher than flue gas temperature measured in the flue pipe.

Installation Conditions	CO₂ Setting	O₂ Setting
Normal Conditions	11%	6.5%
Active Area (Washer, Dryer, Shop)	10 1/2%	6.8%
Outside Oil Tank	10%	7.1%

Note 1: For combinations of above, use lowest CO₂ level or highest O₂ level.

Note 2: When Air Box is used, CO₂ must be checked with **air box cover in place.**

AFTER 15 MINUTES RUNNING, CHECK AND RECORD:

1. DRAFT OVER FIRE/CHIMNEY -0.02" to -0.12" w.c.
2. DRAFT OVER FIRE/POWER VENT -0.10" to -0.12" w.c.
3. CO₂/O₂ See table above
4. STACK TEMPERATURE 350° to 450° F
5. SMOKE TEST Verify 0 smoke at breech

Draft over fire with a chimney should be a minimum of -.02" w.c.

If not, recheck chimney, chimney base and flue pipe for blockage or clean out door openings.

Draft over fire with a power vent (sidewall vent) should be -0.10" to -0.12" w.c.

If not, adjust power vent damper, check power vent fan is turning, or vent blockage.

1. **DANGER:** Verify proper operation of high limit aquastat by closing the bypass valve temporarily and allowing system temperature to rise. At approximately 205° F to 215° F, the high limit aquastat should shut off burner.
2. **DANGER:** Verify proper operation of boiler pressure relief valve by following instructions on pressure relief valve, which calls for a 'try lever test'. Make sure discharge pipe is properly placed to safely contain discharge and open relief valve using the try lever.
3. **NOTICE:** Check that each thermostat operates proper zone.
4. **NOTICE:** Bypass valve must be adjusted to raise return water temperature to approximately 120° F. on start up after any zone valve opens. This prevents condensation from occurring in boiler passages. The digital manager provides condensing protection by closing the zone valves when the return drops below 120° F (130° F when Option switch #1 is on).

The following adjustments will help minimize zone cycling.

- a. On copper baseboard systems, valve normally should be 1/2 open.
- b. On large water volume systems or high heat load systems, where the return temperature from the system is below 120° F, open bypass completely and throttle zone returns to increase bypass flow. If returns are still below 120° F, set option switch 1 to on.

Expanded Digital Manager:

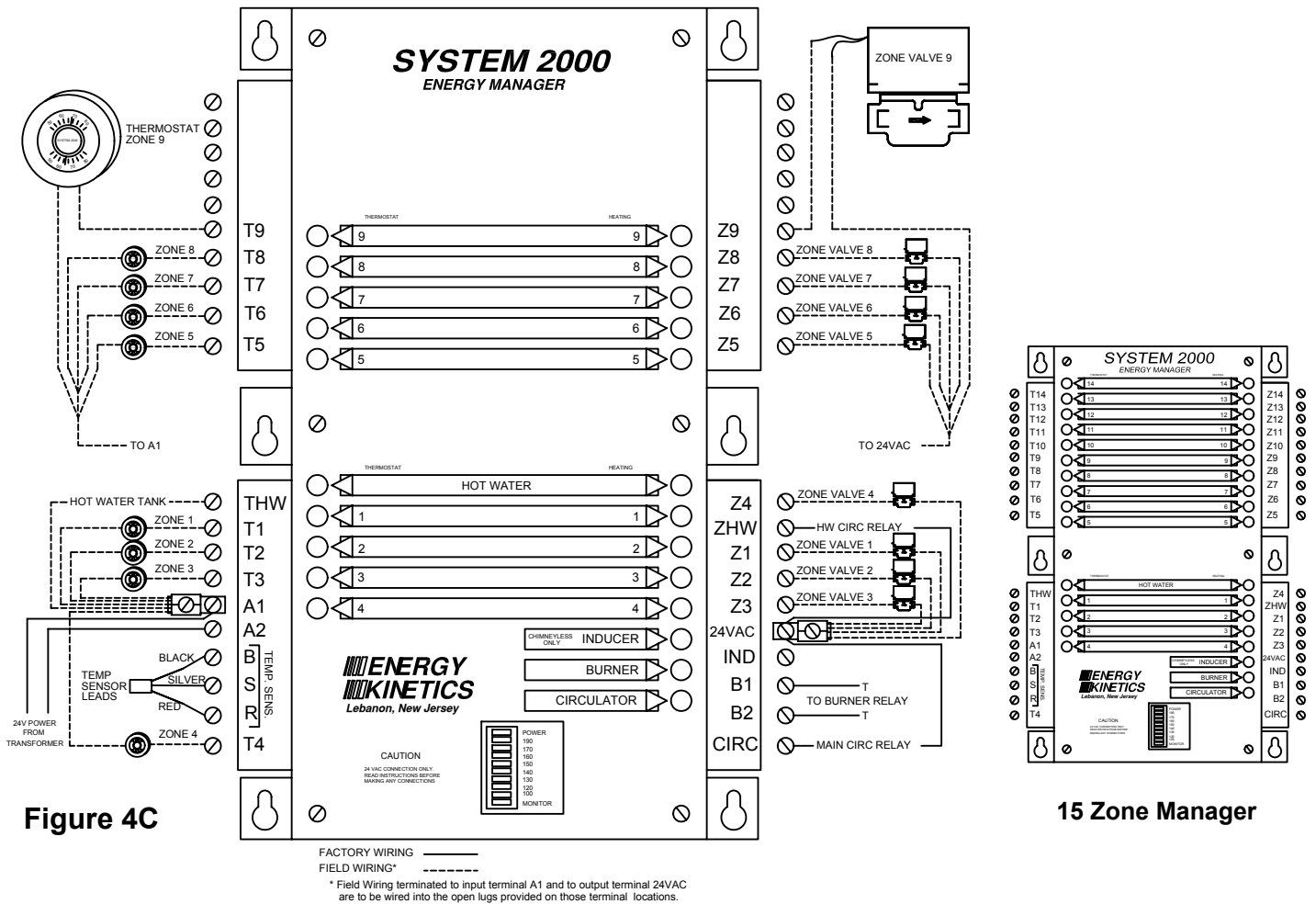

Figure 4C

15 Zone Manager

10 Zone Manager

10 & 15 Zone Manager Installation Instructions:

1. Remove cover from junction box. Use a free knockout on the top of the junction box to mount a second or third transformer, wire black lead to "XFMR" and white lead to "NEUTRAL" on relay board in box. (Use sections marked "120 VOLTS" only.) A second junction box is not needed for the expanded Digital Energy Manager. Wire additional transformer(s) in parallel with first transformer. To wire in parallel, wire terminal "A" on one transformer to "A" on the other. Repeat with other low voltage terminal "B". Verify 24VAC output from all transformers BEFORE reconnecting the Manager.
2. Mount long panel on top of box cover with long screws provided in lower 4 holes with spacers down.
3. Mount expanded Digital Energy Manager to cover plate over four long screws and two wide bolts (top 2 holes).
4. Wire the bottom half of expanded manager as five zone Digital Energy Manager. For top half, attach one thermostat lead to a zone and the other to A1 on lower half of manager. Attach one lead from zone valve or relay to corresponding zone output and the other lead to 24VAC on lower half.
5. Option switches control energy recovery for extra zone outputs (see Location of Switches: **Figure 4B**)

NOTICE: When operating without an expanded manager, use a service card for the bottom half and jumper upper zones from T_(x) to Z_(x).

Security System Interface Wiring:

The Digital Energy Manager features a monitor interface system, which allows the Manager to alert a home security system or other signal light or device when a problem is detected. A three-terminal connector is supplied with each Manager. The wiring detail is shown in Figure 4B. **NOTICE:** Home security systems may require an "abort delay" of one second to avoid a transient signal on Manager power-up. If an abort delay is not available, use Energy Kinetics System Monitor (provided separately part # 10-0168). Alarm contacts are "dry" (no voltage is provided).

Digital Manager Operation:

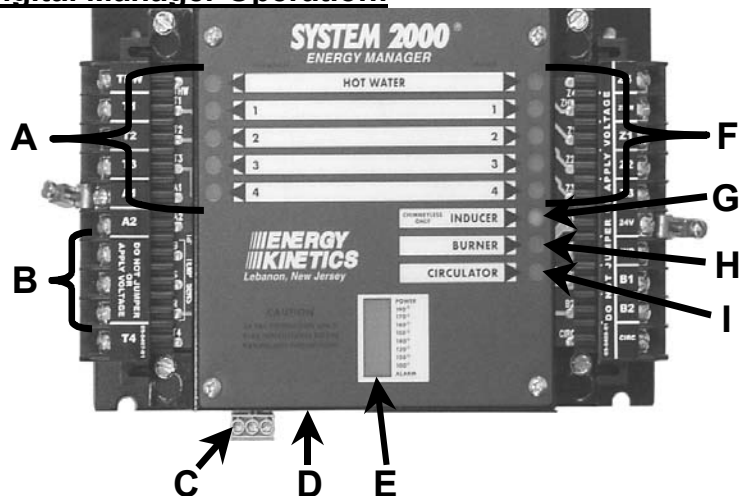

WARNING: Do Not Jump!

If you apply 24VAC to any digital sensor lead with the sensor connected to the Manager, you will burn out both the sensor and the Manager in less than a second.

NOTE: The Manager cannot lockout the primary control on the burner. The 140°F light flashing will usually indicate that a burner lockout has occurred.

Testing Manager Lights: To confirm operation of the Manager lights, turn power off briefly and power up the Manager. On startup, all outputs and temperature lights will turn on for a brief moment.

A) Thermostat Lights:

Indicate a thermostat calling for heat. If all lights are OFF, the burner will not run because there is no call for heat. T₄ is located on the bottom. SET HEAT ANTICIPATORS FOR 0.1 AMPS.

B) Digital Temperature Sensor:

Senses return temperature and is required for manager to work properly. 100°F light flashes if sensor is not working properly. Disconnect RED lead to run in the "Service Board Mode".

C) Monitor Contacts:

For connection to System Monitor or security systems are located here.

D) Option Switches:

Used to customize system settings. Set option switch 2 to **ON** for sidewall vent systems.

E) Temperature Display:

Indicates boiler RETURN temperature, not supply temperature.

- The Manager is the **operating aquastat** and will turn off the burner if **return** temperature reaches 170°F (operating limit).
- The zone outputs will open when the return temperature is above 140°F and close zone outputs when the return temperature drops below 120°F. If a new zone calls when the returns are below 140°F, the new zone will not open until the temperature exceeds 140°F (even if other zones are open).
- The boiler will typically take about 2 minutes to reach 140°F from a cold start.

When the Manager is working properly and has found a condition that needs service, the 100°, 120°, 130°, or 140° light will flash.

F) Heating or Zone Lights:

Indicate 24-volt power from 24VAC to Z_x (Z_{HW}, Z₁, Z₂, Z₃, and Z₄). This provides power to 24-volt zone valves or zone circulator relays. **NEVER JUMPER THIS CONNECTION!**

G) Inducer Light On:

Indicates 24 volts from IND to 24VAC. This pulls in the 24-volt coil on the inducer relay, providing 120-volts to the power vent. *This will only operate with option switch 2 ON.*

H) Burner Light On:

Indicates a closed contact between B₁ to B₂. This is wired to T-T on the burner primary control.

If the burner light goes off, it will delay restart for two minutes to prevent short-cycling the burner (45 seconds for a hot water call).

I) Circulator Light:

On indicates 24 volts from manager CIRC to manager 24VAC. This pulls in the 24-volt coil on the Burner/Main circulator relay, providing 120-volt power to both the main circulator and the burner.

Digital Energy Manager Check

Troubleshooting

The burner will not run unless there is a call for heat (thermostat call) or a call for domestic hot water (tank aquastat).

Note: Do NOT Jumper Connections or Apply Voltage to Test the Manager.

Follow these simple steps: (Continued on next page)

- 1) Look at the Manager
- 2) See what it is telling you is supposed to be happening.
- 3) See if it is happening, and if it is not, find out why (see below).
- 4) If you do not find the problem, perform the 2 Minute Digital Manager Diagnostic to check all Manager functions.

These are **input lights**. These lights indicate when a thermostat or tank aquastat is calling and only come on when there is an external connection.

- If the light is not ON, check the thermostat(s) and thermostat wiring.
- If the light is ON, the thermostat or tank aquastat is calling

These are **zone output lights**.
If the light is ON, the zone valve will be open. For hot water, the bronze circulator will be running.
If the zone valve is not open with the light on, check the zone valve and it's wiring. For hot water, check the hot water relay, wiring and the bronze circulator.

SYSTEM 2000[®]
ENERGY MANAGER

THERMOSTAT HEATING

HOT WATER	
1	LIVING ROOM
2	KITCHEN
3	DEN/FAMILY ROOM
4	BEDROOM

ENERGY KINETICS
Lebanon, New Jersey

CHIMNEYLESS ONLY

INDUCER

BURNER

CIRCULATOR

POWER

190°

170°

160°

150°

140°

130°

120°

100°

MONITOR

CAUTION
24 VAC CONNECTION ONLY.
READ INSTRUCTIONS BEFORE
MAKING ANY CONNECTIONS

INPUT SIDE
(THERMOSTATS)

OUTPUT SIDE

This is the **sidewall vent inducer output**.
This light will only operate if option switch 2 is on.

- If the light is ON, the inducer will be running.
- If the light is ON and the inducer is not running, check the inducer, wiring inducer relay and it's wiring.

This is the **burner output**. This light indicates T-T is made on the burner.

- If the light is ON, the burner will be running.
- If the light is ON and the burner is not running, check the burner, limit tank thermostat, wiring, burner/main circulator relay and burner service switch.

This is the **burner/main circulator output**. This indicates 24 volts is applied to the burner/main circulator relay coil.

- If the light is ON, the main circulator will be running and the primary control will have line voltage.
- If the light is on and the circulator is not running, check the burner/main circulator relay, the circulator and associated wiring.

Remember:
Most no heat problems are not caused by the Manager.
and
The Manager *cannot* cause a burner lockout.

2-Minute Digital Energy Manager Diagnostic

Most no-heat problems are not caused by the manager. Perform this test to prove proper manager function. Do **NOT** replace the manager if it functions properly in these tests.

Step 1: Make sure you have no thermostat calls (turn thermostats down or disconnect after labeling zones).

Step 2: Turn System Switch OFF for 5 seconds. Turn System Switch ON while carefully observing the temperature LED bars. Temperature bars should briefly light *at random*, and then all the temperature lights will turn ON and then OFF. The power light will stay ON.*
If each temperature light comes on and goes off, this proves:

- All the temperature lights work
- The processor is functioning properly



Example of brief random temperature lights on startup

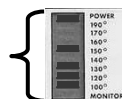

(Continued on next page)

Step 3: Turn System Switch OFF for 5 seconds.

Turn System Switch ON while carefully observing the output lights. Output lights should briefly light at random, and then all output lights will turn ON and then OFF.*

This proves the following:

- All the output lights and outputs work
- The lights (except Burner) are in the output circuit, so 24 VAC should be present
- The processor works (second verification)

System Switch

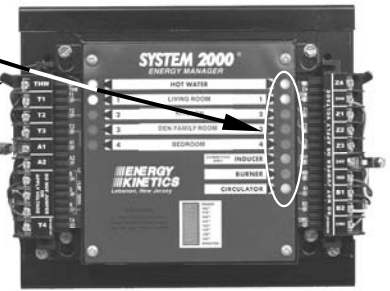

***If you observe problems in step 2 or step 3,** turn Burner Service Switch OFF, disconnect the right hand (output) quick connector and repeat steps 1, 2, and 3. If problem persists, call technical support or replace manager. Note malfunction on warranty tag and return manager to Energy Kinetics. If problem goes away, there is a problem with the output wiring – check all wiring, re-connect quick connector and repeat steps 1, 2 and 3 until problem is resolved.

You're done. The manager is functioning properly. **Remember** to reset thermostats to original set point, to re-connect wiring connections, connect the quick connector and to turn the Service Switch ON.

Additional Manager Tests

Note: If you have a burner lockout, trouble shoot as any conventional burner lockout.

Perform the following tests ONLY if you have either of the following:

Case 1: Zones heating intermittently

Step 1: Have all connected thermostats including hot water aquastat call continuously for at least 10 minutes. Service Switch must be ON. Turn burner switch off to prevent zone overheating and to maintain thermostat calls continuously.

Step 2: Observe thermostat Lights.

- If any thermostat input lights (left side) are not ON, check wiring and thermostats.
- If thermostat input light (left side) is OFF within 10 minutes, and with thermostat call present, thermostat input LED is bad. **Solution:** Move thermostat wire lead and zone valve wire lead to an open zone if available or replace manager.

Case 2: 140 F light Flashing without burner lockout (monitor light is ON)

Step 1: Turn service switch OFF and disconnect right hand (output) quick connector.

Step 2: Using a multi-meter, check the resistance from B1 to B2 on the manager solder strips. This will be an open circuit (infinite resistance).

Step 3: Turn service switch ON and start a thermostat call while observing the resistance from B1 to B2. Burner light should come on.

- If resistance is less than 3 ohms, manager is functioning properly. Look elsewhere for a problem.
- If resistance is greater than 3 ohms after 3 seconds of operation, B1-B2 contact is bad. **Solution:** Replace manager. Note: For 140F light flashing with a good B1-B2 manager relay (step 3 above), see next page.

Digital Manager Sensor Testing

The temperature sensor in the return line allows better boiler control, and virtually eliminates condensation caused by cold returns.

The temperature sensor is a mini computer chip sealed with epoxy inside a copper well. The chip communicates continuously with the Manager thousands of times a minute.

The Digital Manager is *the tester* of the digital temperature sensor. It verifies that it is connected and working properly.

- **The sensor cannot be tested with an ohm meter/volt meter or other device. Doing so could cause it to fail!**
- **The sensor operates on 5 volts DC. Never connect 24 volts to the black, silver or red sensor terminals (labeled B, S, or R.)**
- **A caution: T4 thermostat input is adjacent to R, the red sensor terminal. When making thermostat connections, never do so with power on.**
- **Once firm proper connections have been made, power up.**
- We believe many sensors and Managers have been damaged by 24V being jumped or connected to B, S, or R. Look carefully while making **any** connections to the Manager.

WARNING: Do Not Jump!

If you apply 24V to any digital sensor lead with the sensor connected to the Manager, you will burn out the sensor, the Manager or both in less than a second.

To test the functioning of each output zone, never apply a jumper to the Digital Manager output terminals. The easiest way to test each zone output is to remove the red sensor lead. The Manager should go into Service Board mode. Adjust each thermostat to call for heat and the corresponding zone should come on if working properly.

- Rule #1: Never use a jumper to test the function of the Digital Manager.
- Rule #2: Never use a jumper to test the function of the Digital Sensor.
- Rule #3: Never use a jumper to test the zones outputs.
- Rule #4: Only use a jumper from A1 to the thermostat inputs, if you can't reach the thermostats.
- Rule #5: Always carry a Service Board with you.

Line Voltage Relays

Remember that behind the Manager is the junction box with the line voltage relays. The line voltage relays are controlled by the Manager.

The burner and circulator power is controlled by one line voltage relay. If both burner and circulator are without power, check the relay.

If the domestic hot water circulator does not have power, check the hot water relay.

If equipped with an inducer and the inducer does not have power, check the inducer relay. Also, check to be sure dipswitch #2 is turned "on".

Line Voltage

System 2000 requires 120 VAC. The supply voltage must be within 108 VAC min / 132 VAC max for reliable operation of the boiler and the Manager. An easy way to check the supply voltage is to plug a volt meter in at the service outlet located on the system junction box.

Surge Suppression

The Relay Board located in the system junction box is equipped with built-in surge suppression on the 120VAC circuit. Older systems can be retrofitted using plug-in surge suppressors which we have in stock.

Troubleshooting With the Digital Manager:

Flashing Light indicates that Digital Manager has detected a problem.

Monitor light comes on after a twenty-minute period during which the system attempts to recover.

	<ul style="list-style-type: none"> ● 100° Light Flashing ● Monitor Light ON 	<ul style="list-style-type: none"> ✓ Digital temperature sensor wiring loose or not functional. ✓ Check Sensor wiring. <i>Check lead for damage.</i> ✓ Digital Energy Manager will function in service board mode. Circulator and inducer run constantly, burner runs on high limit aquastat. All inputs turn on respective outputs. ✓ If Manager is left in this mode, <i>reset limit aquastat to 165°/180° F.</i>
	<ul style="list-style-type: none"> ● 120° light flashing, or ● 130° light flashing ● Monitor light ON 	<ul style="list-style-type: none"> ✓ Digital Energy Manager detected a problem. ✓ 120° light flashing: Freeze condition was detected. ✓ 130° light flashing: Excessive temperature condition. Zones could not extract heat from boiler. <i>Check zone valves, heat exchanger and boiler circulation. High limit aquastat may not be functioning.</i>
	<ul style="list-style-type: none"> ● 140° light flashing ● Monitor light ON 	<ul style="list-style-type: none"> ✓ Digital Energy Manager detected a problem. ✓ 140° light flashing: Burner failure or boiler circulation failure. <i>Boiler return temperature has not increased enough to open zones in 20 minutes for fuel oil (80 minutes if option switch #1 is ON)</i> ✓ Does Primary Control need to be reset? YES: Troubleshoot as standard burner lockout. NO: Did homeowner reset control? YES: Troubleshoot as standard burner lockout. NO: Reset Manager. Run through standard heat cycle.
<p style="text-align: center;"><u>TO RESET MANAGER</u></p> <p><i>The Manager can be reset to normal operation by turning the system switch off and back on again.</i></p> <p><i>If condition is not corrected, the appropriate temperature light will flash and again set the monitor light.</i></p>		<ul style="list-style-type: none"> ✓ Does boiler return heat up properly? NO: Check circulator. Possible closed or blocked bypass. YES: Intermittent problem. Check low voltage wiring for tightness from Manager through relay board and cad cell relay to TT. Check line voltage at burner, in and out of cad cell relay. Check limit aquastat for proper operation. See if burner/main circulator relay is properly plugged in and working properly.

Operation without the Digital Manager:

Service Board Mode:

The Digital Manager can be placed into "SERVICE BOARD MODE" by turning off the system switch and removing the RED temperature sensor lead from the left side input connector, and turning power back on. Removing the RED lead does exactly the same thing as inserting the traditional green "Service Board". The traditional service board may still be used if desired. SERVICE BOARD MODE allows the boiler to run like a conventional boiler. The burner is controlled by the high limit aquastat and the circulator runs continuously. If this mode is used, *temporarily reset high limit aquastat to 165°/180° F.*

Temporary Operation with Jumpers: (with partially functional Manager still in place and without service board)

If a particular function of the Manager fails, use appropriate jumper action below *with Manager in place.*

Burner: Jumper BB or TT on burner control. Burner will run on limit whenever Manager calls circulator. The boiler may overheat slightly during energy recovery. Temporarily reset limit aquastat to 165°/180° F.

Main Circulator: Remove blue CIRC lead from right side and connect to A2 on the left side, using an extension lead. The circulator will run constantly and the burner runs on Manager call.

Zone/Hot Water Control: Remove zone valve and thermostat leads for zone. Connect a thermostat lead to A1. Connect a zone valve lead to A2. Wire the remaining thermostat and zone valve leads together. Zone valves will open whenever the Thermostat calls but it will not activate manager.

If a Plug-In Relay Fails: Replace with spare relay. If a spare is not available, temporarily install a relay with 24VAC coil and 120VAC contacts. Contact Energy Kinetics for connection details.

Diagnostics with the Digital Manager:

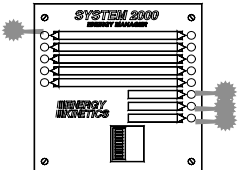
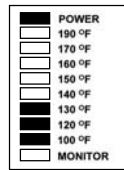
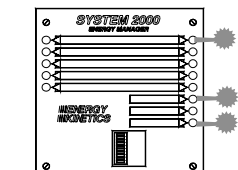
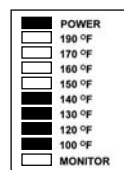
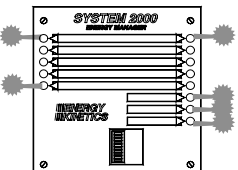
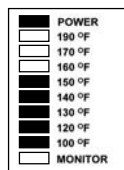
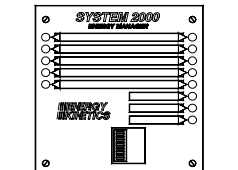
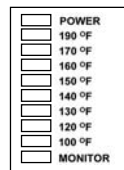
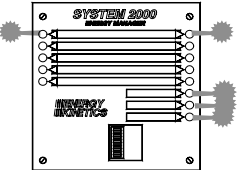
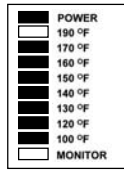
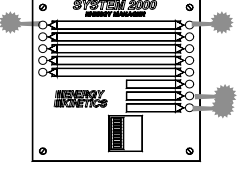
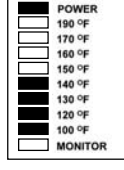
Manager Lights	Temperature	Description	DIAGNOSIS
		(1) <u>Normal Operation</u> • Thermostat calling • No Zone output lights	<ul style="list-style-type: none"> • Preheat cycle – zones will open when boiler return is above 140° F (150° F if option switch 1 is on). • Return temperature dropped during call. Zones close until boiler is up to temperature.
		(2) <u>Normal Operation</u> No Thermostat Call • Zone Outputs On • Circulator On	<ul style="list-style-type: none"> • Energy Recovery cycle will run until time or return temperature is reached. (See option switches 5 through 8.)
		(3) <u>Normal Operation</u> • Hot Water Calling • Thermostat Calling • Only Output zone is hot water	<ul style="list-style-type: none"> • Check option switch 10, hot water priority. "ON" sets up to 25 minutes priority to hot water zone, then other calling zones open.
		(4) <u>Problem</u> • No Lights on Manager	<ul style="list-style-type: none"> • Check Main Power • Check Transformer for 24 volts • Check A1, A2 terminals on Manager for 24 volts
		(5) <u>Problem</u> • Burner Light On • Burner Not Running	<ul style="list-style-type: none"> • Check boiler temperature and high limit aquastat. Set higher for test. Check for boiler circulation failure. • Check burner for power in. • Check burner and/or cad cell relay. Reset if necessary. If still no heat, jumper TT terminals on burner relay to test burner.
		(6) <u>Problem</u> • Inducer Light does not come on	<ul style="list-style-type: none"> • Check option switch 2: "ON" = Power Venting "OFF" = Chimney Venting

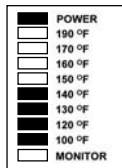
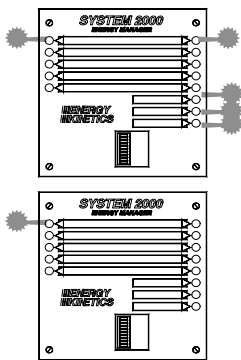

(7) Problem

- Zone Output Light On
- Zone Valve does not open

- Check for 24 volts between 24VAC common and zone in question.
- Check zone valve or circulator on zone calling for operation.

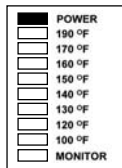

(8) Normal Operation

- Dim light on thermostat calling.

- A dull yellow light is common with a power-stealing thermostat. It is not a call for heat.

- **Burner Restart: A two (2) minute delay is built into the control. (45 seconds for a Hot Water call).**
- **Reset the Digital Manager by turning system switch off and back on again.**
- **Service Board Mode- With power off, remove the RED lead of the temperature sensor to run in this mode.**
- **A Service Board for temporary operation without Manager is available. This is interchangeable with the Classic and Digital Managers. Rebuilt Managers are available for nominal rebuild charge and require the return of a Manager (Manager must be re-buildable).**

Annual Maintenance:

Summary: Each year an efficiency check is recommended as part of basic maintenance. It is recommended that smoke test, CO₂/O₂, stack temperature, breech draft and front draft (over fire) be checked. A draft loss through boiler of up to .04" w.c. (.05" w.c. for EK2 at maximum firing rate) is normal. If greater, inspect and clean as below. If readings compare favorably with those of the original installation combustion tests, no further cleaning may be required.

Draft Loss Definition: The 0.04" w.c. draft loss through boiler is found by subtracting the over fire draft reading from the breech draft reading. For example, if the breech draft is -0.04" w.c., and over fire draft is -0.02" w.c., then subtracting the two readings gives a draft loss of 0.02" w.c., which is acceptable.

1. Check system efficiency and draft loss when you arrive. If it is about the same as the prior year, it is quite certain that not much has changed.
2. Loss in efficiency or excessive draft loss indicates a build up within boiler and the boiler should be cleaned.
3. For sidewall vent systems, inspect and clean entire sidewall vent system, including fan wheel.
4. **CAUTION: A DUST MASK SHOULD ALWAYS BE WORN AS A PRECAUTIONARY MEASURE PRIOR TO ACCESSING ANY INTERNAL BOILER SURFACES.**
5. Prior to opening the rear cover, ensure that power to the boiler is shut off and that all objects that may interfere with the opening cover are removed. Shut off the fuel supply.
6. **OPENING THE BOILER:** Remove nuts at back of unit uniformly. Loosen jacket screws at back, sides and top.
7. Pull rear cover and insulation as a single unit straight back, by placing one hand under jacket top and one hand underneath rear cover. A slight tap may be required to loosen cover.
8. Remove chamber liner, but do not attempt to remove combustion chamber.
9. Inspect the insulation and liner components for any signs of damage. Replace if necessary.
10. Inspect the flue passages and the flue box for accumulations of soot or scale.
11. Clean passages only if dirty. Follow the procedure below, otherwise skip to #12.

CLEANING PROCEDURE

- a. **CAUTION: DO NOT TOUCH SCRAPE, VACUUM, OR MUTILATE COMBUSTION CHAMBER.** The first inner pass should not require any cleaning. Insert vacuum tube into back of bottom passage and then brush outer passages from top of unit to bottom on left and right in each circuit. Vacuum loose scale and soot at the bottom of the outer pass and in the flue box.
 - b. If there is a large accumulation of scale, then the boiler is probably operating with cold return temperatures. Open bypass valve fully. Set the Digital Manager Option Switch 1 to "ON" to maintain a higher return temperature during operation. If scaling persists, increase firing rate (see "Oil Burner Operation" section and "Oil Burner Settings" Table).
 - c. Check flue pipe and base of chimney to be certain there is no blockage of flue passage.
12. Replace the chamber liner and cover by pushing end cover with 2" insulation as a single unit back on. Tighten nuts and jacket screws uniformly. Do not over tighten; tighten snugly enough to compress the door insulation.
 13. Inspect and check the following. Adjust/replace parts as necessary.
 - Ignitor
 - Porcelain Conditions (remove drawer assembly)
 - Fan/Air Inlet for dirt and lint
 - Electrode Setting
 - Burner End Cone (through tube opening)
 - Nozzle for coking or heat

14. Inspect the amulet for cracking or other physical damage. Replace the amulet if necessary (see section "Amulet Replacement"). Check the condition of the oil filter. Change annually or as conditions require.
15. Lubricate motors. Open/close zone valves several times to check that they move freely.
16. Back flush plate heat exchanger.
17. Start burner. Check safety functions as described under "Oil Burner Operation", including high limit aquastat, pressure relief valve, puff switch, and cad cell relay.
18. Measure and reset air for CO₂/O₂.
19. Check and record:
 - a. DRAFT OVER FIRE/CHIMNEY: -0.02 to -0.12 in w.c.
If not, re-check chimney, chimney base and flue pipe for blockage or clean out door openings.
 - b. DRAFT OVER FIRE/SIDEWALL VENT: -0.10 to -0.12 in w.c.
If not, adjust power vent damper, check power vent fan rotation, or vent blockage.
 - c. DRAFT IN FRONT (test over-fire, remove brass plug): Should be negative.
 - d. CO₂/O₂ (test over-fire, combustion test port): See "Oil Burner Operation" for suggested levels.
 - e. STACK TEMPERATURE: 350 ° to 450 ° F
 - f. SMOKE TEST: Verify 0 smoke at breech
20. All cover plates, enclosures, and guards must be maintained in place at all times, except during maintenance and servicing.
21. **Caution:** Do not attempt to start the burner when excess oil has accumulated, when the unit is full of vapor, or the when the combustion chamber is very hot.
22. **Caution:** Always keep the fuel supply valve shut off if the burner is shut down for an extended period of time.
23. **Caution:** Do not start the burner unless the rear cover is closed and the nuts have been properly tightened.

Replacement Parts:

To order replacement parts, specify serial number stamped onto nameplate, part description and part number from parts list and assembly drawing on the next page.

Amulet Replacement

It is recommended that a new ceramic sleeve "amulet" be installed each time the air tube is removed from unit. See instructions that come with each amulet. Not using an amulet will allow excessive heat back to the front jacket and may damage burner tube. Be sure to order the proper part number shown in the Assembly Drawing.

Combustion Chamber Replacement

The combustion chamber is of high quality material and will normally not need to be replaced. A replacement chamber, if required, is available from Energy Kinetics. The proper part number for the System 2000 Boiler chamber must be specified when ordering. For interim operation, the unit may be run without a combustion chamber if necessary. Ensure that the burner head is protected by the amulet, wet pack or a similar material.

To install the replacement. CAUTION: A dust mask should be worn during procedure:

1. Open boiler by removing burner, back cover, back chamber liner, and chamber.
2. Spray chamber with a water mist to minimize disturbance and breakage of chamber material.
3. Clean out the old chamber completely where it passes through the front cover.
4. Coat all front surfaces of combustion chamber with a coat of good grade retort cement and re-insert chamber with key in proper orientation until it is flush with front cover.
5. Cement foot support in place at back end of chamber.
6. Replace back chamber liner and back cover.
7. Tighten nuts securely. Do not over tighten; tighten snugly enough to compress the door insulation.
8. Seal chamber at front cover with retort cement.
9. Re-install burner, with a new ceramic sleeve "amulet" (see "Oil Burner Mounting").
10. Confirm proper setup and operation of burner (see "Oil Burner Operation").

Replacement Parts

Obtain replacement parts from your local Energy Kinetics dealer.
 Contact Energy Kinetics at 800-323-2066 or www.energykinetics.com for help locating your nearest authorized dealer.

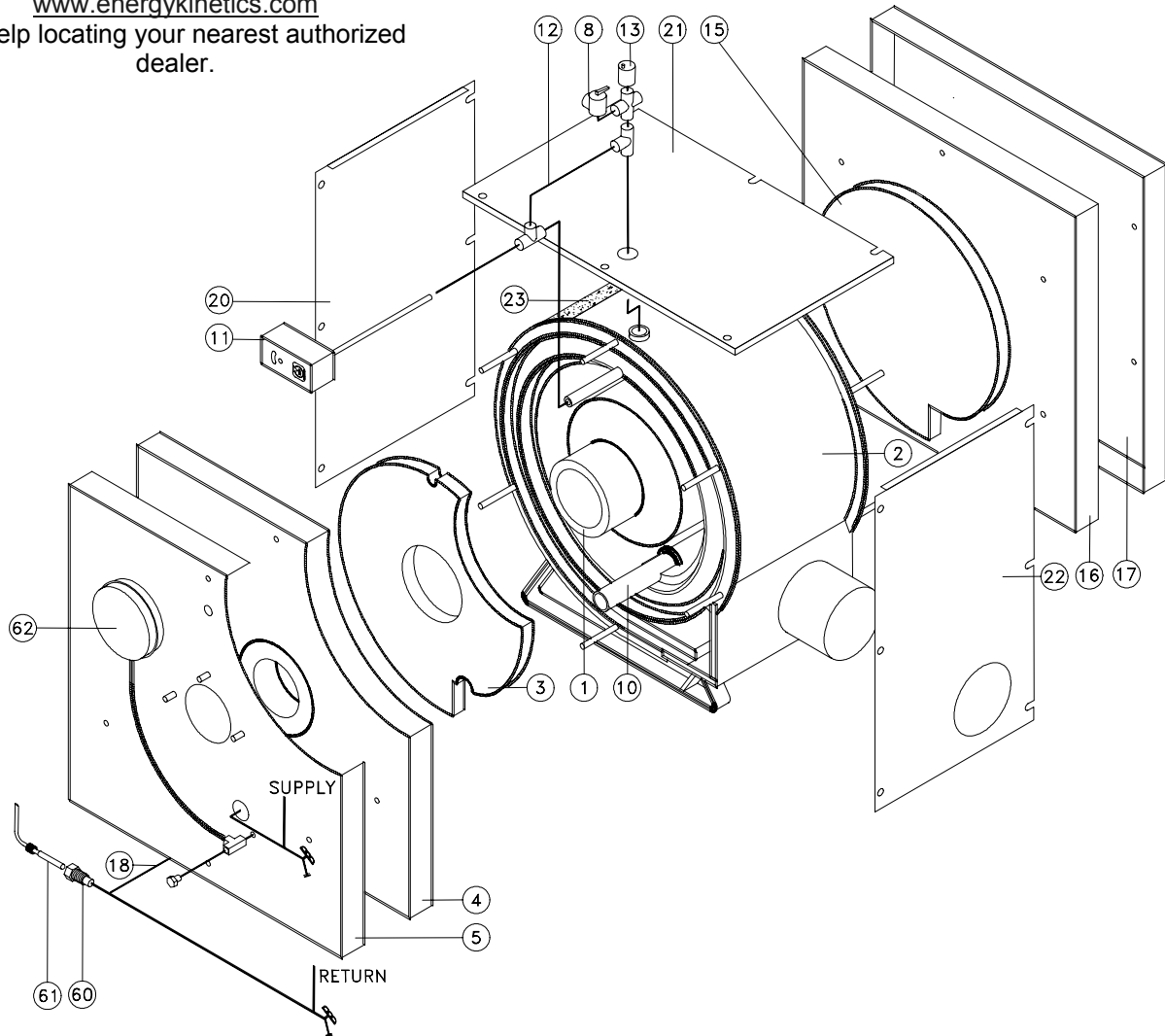

ITEM	PART NO.	DESCRIPTION	ITEM	PART NO.	DESCRIPTION	
1	10-0401	Combustion Chamber w/foot (EK1)	17	10-0405	Jacket: Back (EK1)	
	10-0472	Combustion Chamber w/foot (EK2)		10-0405-2	Jacket: Back (EK2)	
2	10-0390	Energy Converter (EK1)	18		Return Pipe Header	
	10-0390-2	Energy Converter (EK2)	20	10-0408	Jacket: Left Side (EK1)	
3	10-0402	Chamber Liner: Front (EK1)		10-0408-2	Jacket: Left Side (EK2)	
	10-0402-2	Chamber Liner: Front (EK2)	21	10-0409	Jacket: Top for side flue opening (EK1)	
4	10-0403	Insulation Board: Front (EK1)		10-0409-1	Jacket: Top for vertical flue opening (EK1)	
	10-0403-2	Insulation Board: Front (EK2)		10-0409-2	Jacket: Top for side flue opening (EK2)	
5	10-0404	Cover: Front w/Studs (EK1)		10-0409-2T	Jacket: Top for vertical flue opening (EK2)	
	10-0404-2	Cover: Front w/Studs (EK2)	22	10-0410	Jacket: Right Side for side flue (EK1)	
6 & 7		(No Longer Used)		10-0410-1	Jacket: Right Side for vertical flue (EK1)	
8	10-0516	Relief Valve ASME 30 psi		10-0410-2	Jacket: Right Side for side flue (EK2)	
9	10-0420	Tridicator Gauge (not shown)		10-0410-2T	Jacket: Right Side for vertical flue (EK2)	
10		Supply Pipe Header	23		Insulation for Jacket	
11	10-0413	Limit Aquastat	60	10-0175	Temperature Sensor Well	
12		Vent Piping	61	10-0417DS	Temperature Sensor	
13	10-0434	Air Vent Valve	62	10-0178	Puff Switch	
14	10-0050	(Previously Baffle, No longer used)	ITEMS NOT SHOWN			
15	10-0406	Chamber Liner: Back (EK1)				
	10-0406-2	Chamber Liner: Back (EK2)	10-0418D	Digital Manager 5 zone	10-0456	Air Tube/Flange
16	10-0407	Insulation Board: Back (EK1)	10-0412A	Relay (Main Circ/HW Tank)	10-0121	Service Board
	10-0407-2	Insulation Board: Back (EK2)	10-0450	Amulet (Ceramic Sleeve)	10-0418	Classic Manager



LIMITED LIFETIME WARRANTY For Residential Water Boilers

By this Warranty Statement, Energy Kinetics, Inc of Clinton Township, New Jersey, issues limited warranties subject to terms, conditions, exceptions and exclusions listed below.

These Warranties are issued only to the person or entity which owns the building in which the boiler is installed at the time of original installation and only for such portion of the warranty periods as such person or entity owns such building (hereinafter, the "End User").

I. THREE YEAR -LIMITED WARRANTY FOR RESIDENTIAL WATER BOILERS

Energy Kinetics warrants that its residential heating System 2000, with residential water boiler, Models EK1 and EK2, is free from defects in material and workmanship for three years from the date of installation. If any parts are found to be defective in manufacture, Energy Kinetics will repair or replace the defective parts. Exception: Honeywell Zone Valves

II. ADDITIONAL COMPONENT LIMITED WARRANTIES

1. Energy Kinetics warrants that its Digital Energy Manager is free from defects in material and workmanship for a period of five years from the date of installation. The warranty is extended to the End User for the lifetime of the unit by a manufacturer sponsored rebuild program offered at nominal cost.
2. Energy Kinetics hereby assigns to the End User limited warranties of the original manufacture of components supplied by Energy Kinetics to the extent or duration assignable.
3. If any such component is found defective, Energy Kinetics' responsibility is solely to repair or replace the defective part at its or the original manufacturer's option.

LIMITED LIFETIME WARRANTY FOR THE PRESSURE VESSEL

During the lifetime of the original owner in the original place of installation, Energy Kinetics warrants that those parts, which comprise the pressure vessel of the residential hot water boiler, remain free of defects in material or workmanship under normal usage.

In the event that such pressure vessel is found to be defective in material or workmanship during the first ten years, Energy Kinetics will repair or replace the pressure vessel at its option and include a labor allowance per the published schedule. After 10 years, there will be a proportionate charge based upon the time the defective assembly was in service. The proportionate charge will be equal to the appropriate percentage of the trade list price of such pressure vessel at the time the warranty claim is made as determined in the following:

YEAR:	1 st	11 th	12 th	13 th	14 th	15 th	16 th	17 th
	Percent of Trade list Price:							
	0%	5%	10%	15%	20%	25%	30%	35%
YEAR:	18 th	19 th	20 th	21 st	22 nd	23 rd	24 th	25 th
	Percent of Trade list Price:							
	40%	45%	50%	55%	60%	65%	70%	75%
YEAR:	25 TH and Above: 75% of Trade list Price							

IMPLIED WARRANTIES OF FITNESS FOR A PARTICULAR PURPOSE AND MERCHANTABILITY SHALL BE LIMITED TO THE DURATION OF THE EXPRESS WARRANTY-ENERGY KINETICS EXPRESSLY DISCLAIMS AND EXCLUDES ANY LIABILITY FOR CONSEQUENTIAL OR INCIDENTAL DAMAGES FOR BREACH OF ANY EXPRESS OR IMPLIED WARRANTY.

This Warranty gives you specific legal rights and you may have, also, other rights which vary from state to state.

EXCEPTIONS AND EXCLUSIONS

1. The warranty is subject to the condition that the residential boiler must have been installed and serviced in accordance with Energy Kinetics instructions, the basic BOCA Building Code, local statutes and ordinances and accepted good industry practice.
2. This warranty does not cover components that are part of the heating system but which were not furnished by Energy Kinetics.
3. This warranty does not cover the workmanship of any installer of Energy Kinetics residential water boiler. In addition, it does not assume any liability of any nature for unsatisfactory performance caused by improper installation.
4. This warranty does not cover improper burner adjustments, control settings, care or maintenance.
5. This warranty does not cover any labor for removal or reinstallation of the alleged defective part, transportation to Energy Kinetics if necessary and other materials necessary to perform the exchange.
6. This warranty does not cover failure of the pressure vessel other than defects in material or workmanship and shall specifically exclude any other reason including but not limited to a) lack of water b) freezing c) excessive pressure d) floods e) fire f) acts of God g) corrosion of internal or fireside surfaces h) improper water conditioning l) improper maintenance of external fireside surfaces j) operation with defective fuels or other additives which cause deposits to collect or corrosion to occur in or on the pressure vessel.



LIMITED WARRANTY
(Continued from Previous Page)

7. Systems installed with chimneyless, through the wall venting option may have less than complete or poor combustion which may cause sooty fumes, odors or gradual discoloration of the area near the vent (exhaust) outlet. Poor combustion is generally the result of a burner being out of adjustment for a number of reasons, including but not limited to fuel condition and combustion air supply. Energy Kinetics does not guarantee nor warranty that all times the exhaust contents will be without a trace of soot or odor for reasons described above. Periodic cleaning and repainting of the area around the vent hood may be required if the appearance is objectionable in the view of the end user. Such cleaning or repainting is not the responsibility of the service company, installer or manufacturer.

WARRANTY TRANSFER

Within five years from the date of installation, by completion of the Warranty Transfer Agreement, the original owner may transfer the warranty to a new owner by payment of a \$75 registration fee.

WARRANTY SERVICE

For prompt warranty service, notify the installer who in turn will notify Energy Kinetics that the purchaser believes there is a defect in material or workmanship covered by this warranty statement.

If within 30 days of the discovery, this action does not produce a prompt response, notify Energy Kinetics, Inc. 51 Molasses Hill Road, Lebanon, NJ 08833, in writing with details to support the warranty claim.

The End User is required to make available for inspection by Energy Kinetics or its representative, the parts claimed to be defective and, if requested by Energy Kinetics, to ship said parts prepaid to Energy Kinetics at the above address for inspection or repair. In addition, the homeowner agrees to make all reasonable efforts to settle any disagreement arising in connection with this claim before resorting to legal remedies in courts. If you have any questions about the coverage of this warranty, contact Energy Kinetics at the above address.

Warranty Transfer Agreement

(I/We), the undersigned, as the original purchaser of the **SYSTEM 2000**[®] home heating system, and is forwarded the *Warranty Registration* within three (3) months of installation of (my/our) **SYSTEM 2000** to Energy Kinetics, Inc., and this being within five (5) years of the date of the original installation, (I/we) hereby transfer our Lifetime Limited Warranty to the new owner(s) of the home located as noted below. Warranty coverage begins on the date of original installation.

SYSTEM 2000 Serial Number: _____ **Date of Original Installation:** _____

Name of original purchaser of **SYSTEM 2000**: _____
Print or Type full Name(s)

Located at this street address: _____

City: _____ State: _____ Zip: _____

TRANSFER TITLE of ENERGY KINETICS' WARRANTY TO: _____
Print or Type full Name(s)

New Owner(s) of the **SYSTEM 2000** located at the address noted above. Title to be effective, _____
and continues uninterrupted coverage as is left on the original warranty. Enter Date of Title Transfer

(Example: If the original owner has used 4 years, 3 months and 10 days of the warranty, the new homeowner warranty transfer begins at 4 years, 3 months and 11 days and continues to the end of the warranty as described on the back of this agreement or until the new homeowner sells the residence).

Enclosed is a check for \$75.00 to register and maintain the warranty as described on the back of this Warranty Transfer Agreement to the new homeowner named above. Please make check payable to Energy Kinetics, Inc.

Agreed to by the Original Homeowner: _____ Accepted: _____
Original Homeowner Signature New Homeowner Signature

***** For Office Use Only *****

Energy Kinetics, Inc. Received Transfer Information: _____ \$75.00 Received _____ Check No. _____
Date Received and Registered

Confirmation of Transfer mailed to New Homeowner: _____ By: _____
Date Office Personnel