

CLICK ANYWHERE on THIS PAGE to RETURN to AIRCO OLSEN ECR FURNACE MANUALS & INFORMATION at InspectApedia.com

DUOMATIC-OLSEN ULTRAMAX

CONDENSING
GAS
FURNACE

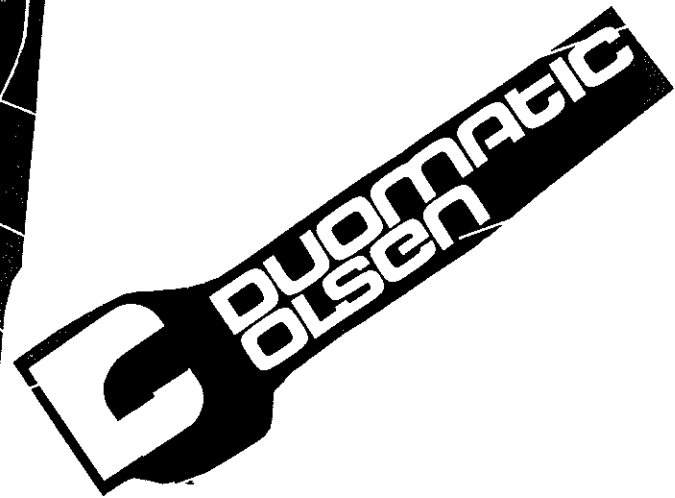

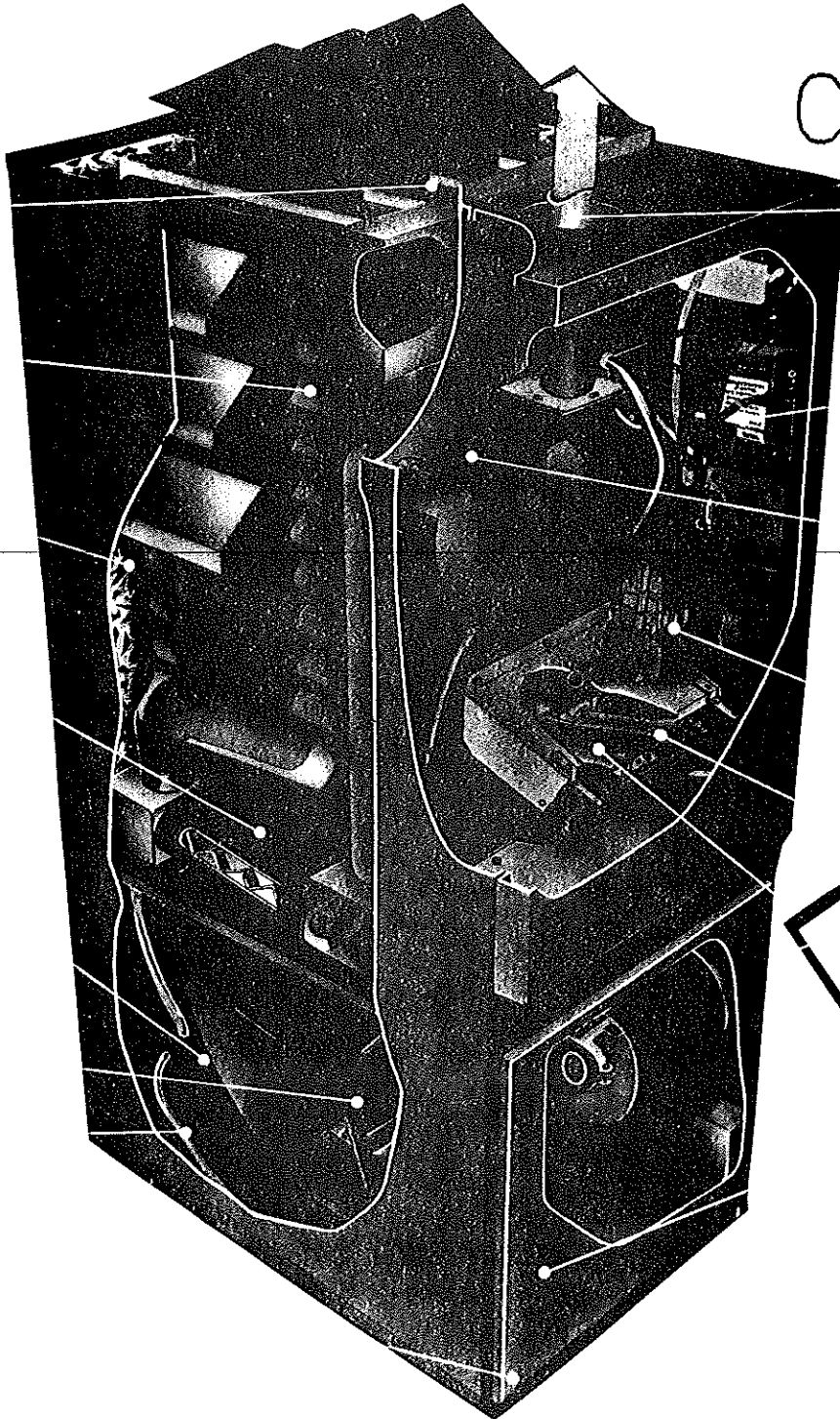
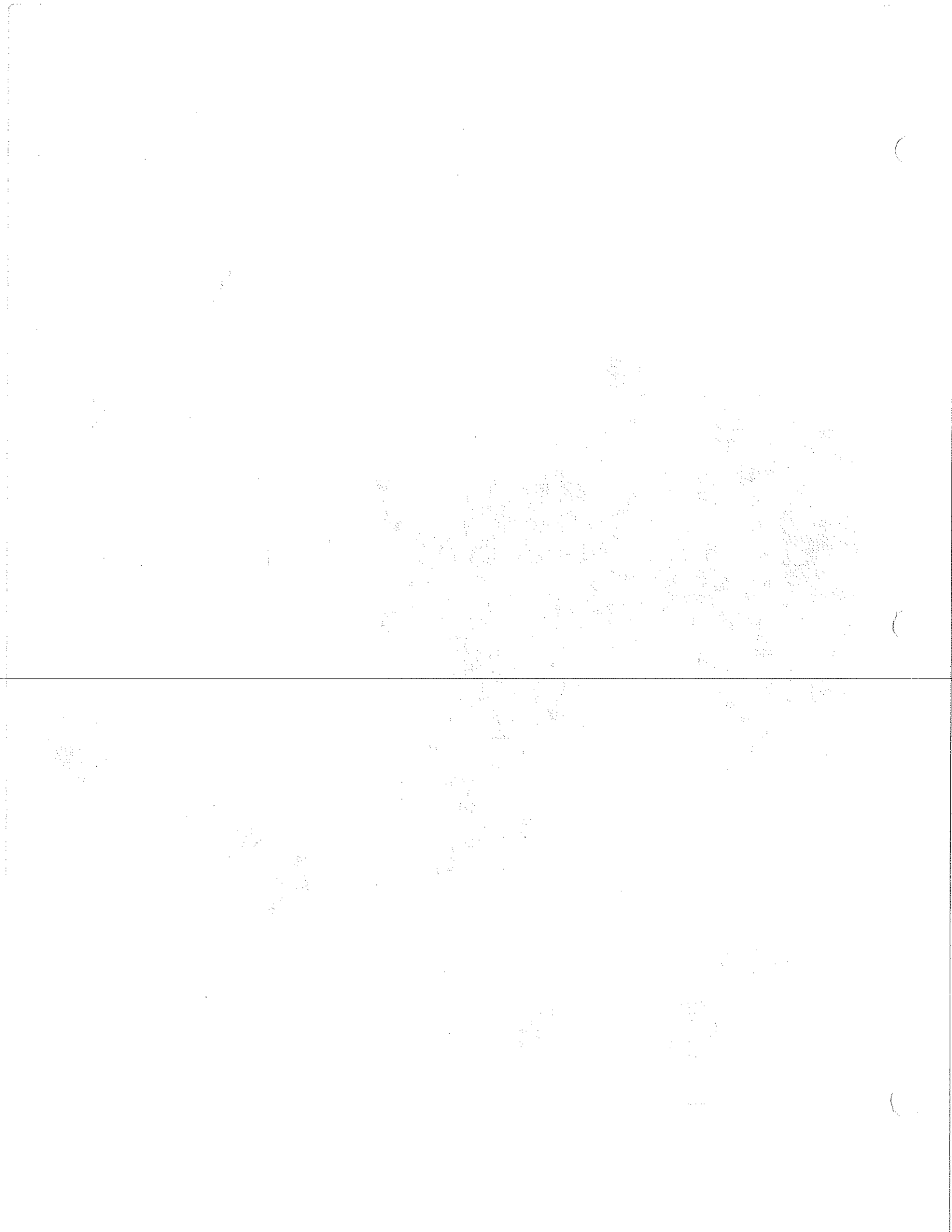

GENERAL REQUIREMENTS

Installation should be in accordance with the National Fuel Gas Code ANSI Z223.1-1984, and other applicable local codes, including requirements of local utilities.

Adequate clearances must be provided as per the rating plate and installation instructions.

The furnace shall not be installed directly on carpeting, tile or other combustible material other than wood flooring.

This unit has been certified for closet installation.

COMBUSTION AIR REQUIREMENTS

Standard combustion air requirements as per the Customer Service Manual.

GAS PIPING

The furnace and its individual shut-off valve must be disconnected from the gas supply piping system during any pressure testing of that system at test pressures in excess of 1/2 p.s.i.g.

DERATION

Standard deration as per the Customer Service Manual. If furnace is installed at altitudes over 2,000 ft. above sea level, the furnace should be derated 4% for each 1,000 ft. above sea level.

MANIFOLD PRESSURE

Only small variations in gas input may be made by adjusting the regulator. In no case should the final manifold pressure vary more than 0.3" W.C. from the specified pressure.

THERMOSTAT ANTICIPATION

The thermostat heat anticipator should be set with ampmeter, according to the current drawing of the induced draft blower relay and spark ignition control being used, or by table in installation instructions.

VENTING

- A. Materials:
Schedule 40, ABS or PVC 2 inch plastic pipe and fittings.

WARNING: Due to the low temperatures of the combustion products, the moisture contained in the flue gases will condense when they meet the cooler outdoor temperatures. This condensate is slightly acidic and may cause some discoloration of the building's exterior finish or may freeze on the building exterior. Follow installation instructions closely to minimize the effect of the condensate on the structure.

- B. Vent Length:

The maximum overall equivalent vent length is 60 ft. (maximum 4 -90 degree ells to be installed).

Fittings: A 90 degree elbow is equivalent to 10 feet of straight pipe. A 45 degree elbow is equivalent to 5 feet of straight pipe.

- C. Slope of Venting

The vent should be sloped upward from the furnace a minimum of 1/4 inch per foot.

The vent should not be attached directly to the floor beams, but should be adequately supported every 3 feet.

D. Vent Termination

The vent termination for this unit is supplied and must be used for vent termination.

E. Insulation

When vent piping passes through an unheated space it must be insulated.

F. Location of Vent Terminal

The vent terminal must not be located:

1. Less than 6 ft. from a combustion air inlet of another appliance.
2. Less than 3 ft. from any building opening.
3. Directly above a gas meter or service regulator.
4. Directly above a walkway unless 7 ft. above grade.
5. It is recommended that the vent terminal be located 3 ft. above grade; 1 ft. minimum above grade must be maintained.

G. Location Of Vent Terminal

It is recommended that the vent terminal be located:

1. No less than four feet from an inside corner formed from two exterior walls.
2. No less than four feet from building soffit.
3. On the sides of the building which are not exposed to the prevailing winds.
4. Where it is accessible for maintenance and inspection.

H. Methods of Vent Termination

NOTE: It is recommended that the unit be vented horizontally where possible.

HORIZONTAL VENTING

Horizontal venting must terminate in the supplied terminal kit as per pictures #1 and #2.

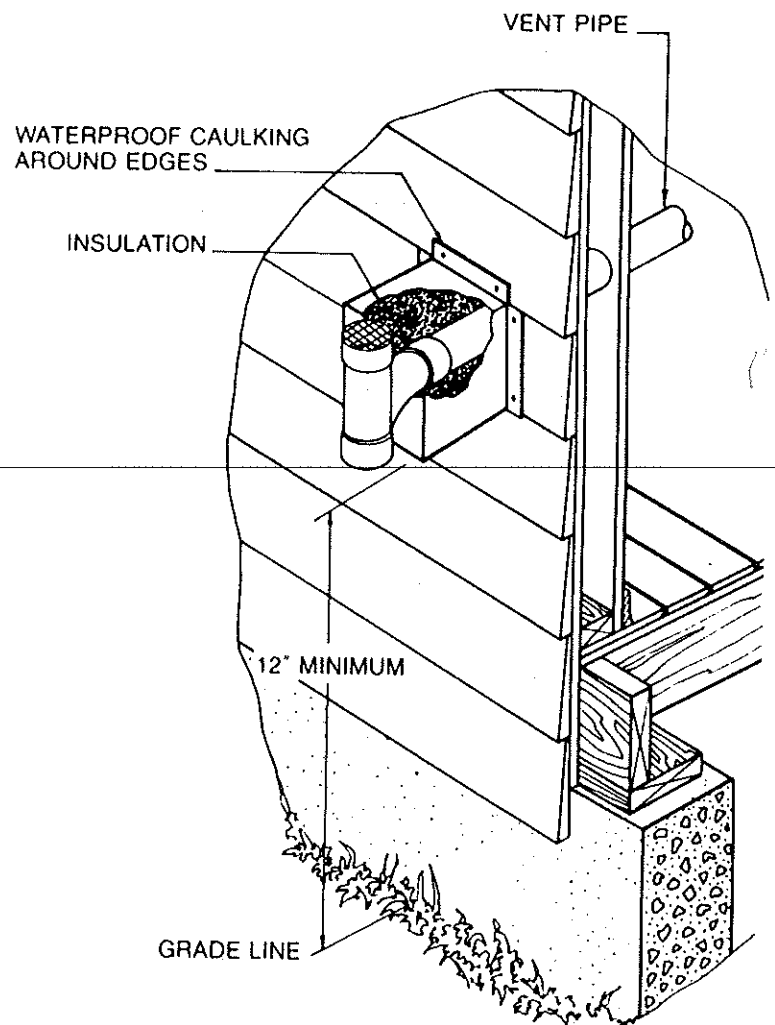

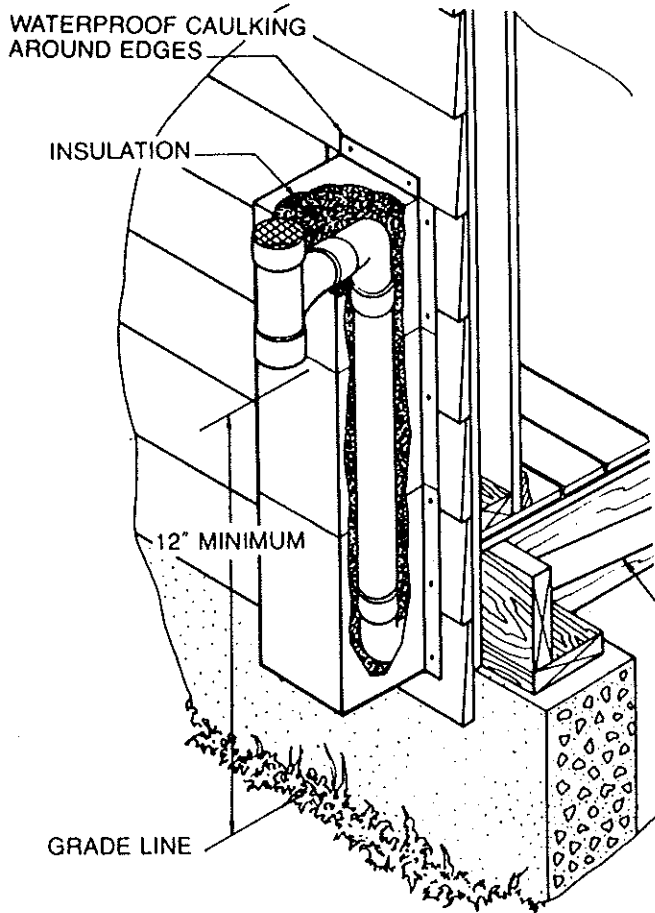

VERTICAL VENTING

A. Using existing vent or chimney

The ABS or PVC plastic pipe can be run through an existing chimney which is not shared by another appliance. The plastic vent pipe must be run from the furnace, up the existing chimney to the factory supplied vent terminal.

At the end of the existing chimney a casing should be made to house the plastic pipe. This casing should extend one foot above existing chimney and be made of an acid resistant material.

The entire casing must be insulated, and the top sealed to become water-tight.

It is necessary to use the 90 degree elbow and the Y-tee terminal supplied, as shown in Figure A. NO OTHER METHOD OF

VENTING IS APPROVED.

See Figure A for venting through an existing vent or chimney.

B. Using New Vent Or Chimney

When vertical venting through the roof in a new installation, or when an existing vent or chimney is not available.

The venting method for this type of installation is similar to the method used with an existing vent or chimney. A vent casing should be fabricated which is a minimum of 5 inches in diameter.

It should be equipped with a cap which is sealed against the weather. It must go through a flashing at the roof and be secured to the roof in the attic space.

The vent pipe must be insulated where it goes through an unheated space.

The 90 degree elbow and the Y-tee from the supplied terminal kit must be used.

See Figure B for venting vertically through a new vent casing.

NOTE: This vent casing must hold the Y-tee outlet at least two feet above the roof.

NOTE: This appliance cannot be vented into a conventional chimney.

SEQUENCE OF OPERATION

1. Thermostat calls for heat.
2. Induced draft blower relay is activated.
3. Induced draft blower starts.

4. When induced draft blower reaches near full R.P.M., static pressure switch closes.
5. 30 second pre-purge timing sequence is activated on spark ignition control.
6. When 30 seconds has elapsed, pilot valve opens and electrode spark begins.
7. When pilot flame is established, and proven, the spark will cease and the main valve will open.
8. Main burner will open.
9. System will remain in this state until the call for heat is satisfied.
10. Thermostat opens.
11. Induced draft blower relay opens, ignition control is de-energized, closing main and pilot valves. The induced draft blower begins to coast to a stop.

Models HCS (70, 70M), HCS (60, 60M) are preset at $-.65''$ W.C. or $-.5''$ W.C.

For HCS 60A and HCS 60 AM at $-0.4''$ W.C.

For HCS (60S, 60SM), HCS (50, 50M) at $-0.95''$ W.C.

For HCS 40, 40M at $-0.6''$ W.C.

FAN AND LIMIT CONTROL

The unit comes with a Honeywell or White-Rodgers combination control.

These controls do not use a heater for pre-starting the blower motor.

The limit is preset at a setting of 250°F for Honeywell and 240°F for White-Rodgers.

12. As the induced blower begins to slow down the pressure switch will open.
13. The system will remain idle until the next call for heat.

CONTROLS

Intermittent Control Lock-Out. (Used on S86E and G, S860 C and 50C49 ignition systems). If pilot flame is not established and proven within 90 seconds the intermittent ignition system will lock-out indefinitely. Turn thermostat down for 1 minute and backup to restart control.

PRESSURE SAFETY SWITCH

The pressure switch on models HCS (90, 90M), HCS (80, 80M) is factory preset at $-.65''$ W.C.

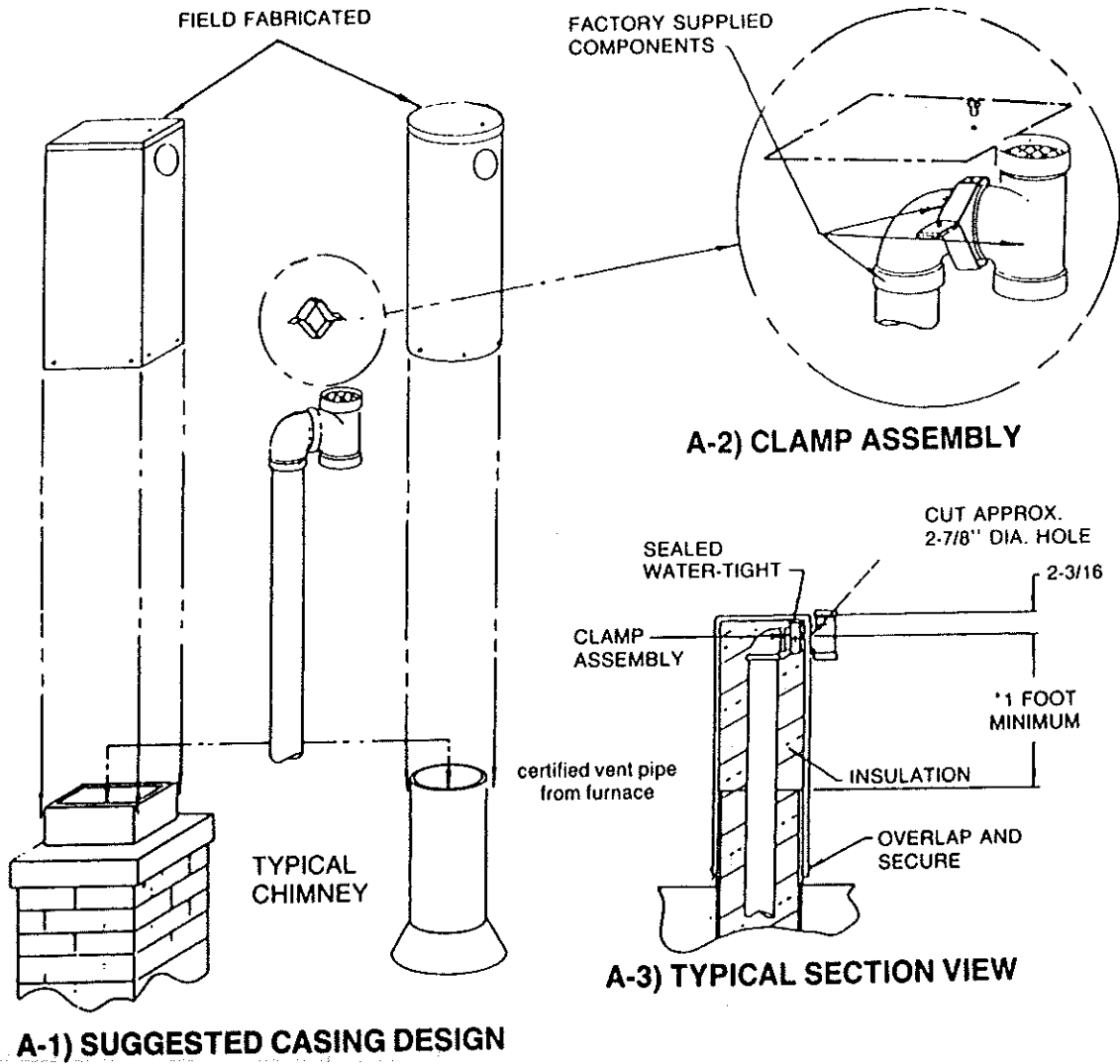

CASING BUILT BY INSTALLER:

1. Must raise "tee" one foot above existing vent.
2. Must be made of acid resistant material.
3. Must use 90° elbow and "tee" as shown.
4. Must be insulated.
5. Must be water-tight.
6. Must be mounted securely to existing vent or chimney.

NOTE: All connections are to be cemented with U.L certified cement.

*CONSIDER MAXIMUM SNOW ACCUMULATION FOR LOCALITY.

FIG. A – VENTING USING EXISTING CHIMNEY

FIELD FABRICATED

FACTORY SUPPLIED COMPONENTS

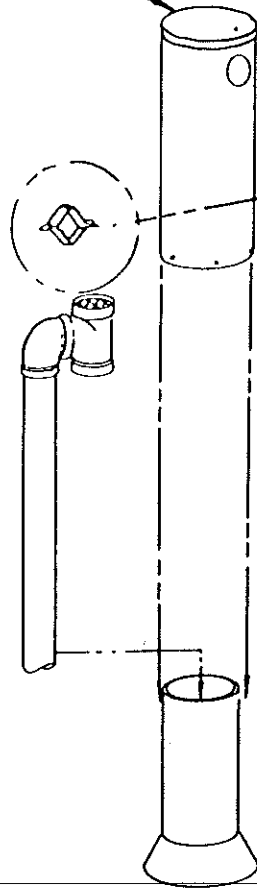

B-2) CLAMP ASSEMBLY

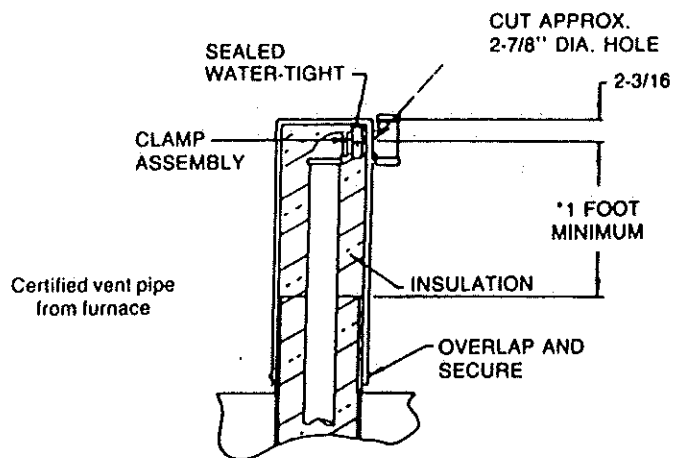
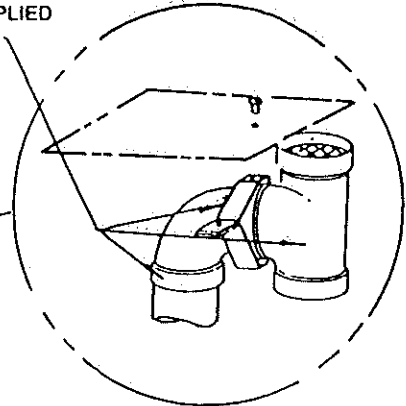

B-3) TYPICAL SECTION VIEW

B-1) SUGGESTED CASING DESIGN

CASING BUILT BY INSTALLER:

1. Must raise "tee" one foot above existing vent.
2. Must be made of acid resistant material.
3. Must use 90° elbow and "tee" as shown.
4. Must be insulated.
5. Must be water-tight.
6. Must be mounted securely to existing vent or chimney.

NOTE: All connections are to be cemented with U.L certified cement.

*CONSIDER MAXIMUM SNOW ACCUMULATION FOR LOCALITY.

FIG. B - VENTING USING NEW CHIMNEY

WIRING DIAGRAM HIGH EFFICIENCY HCS SERIES

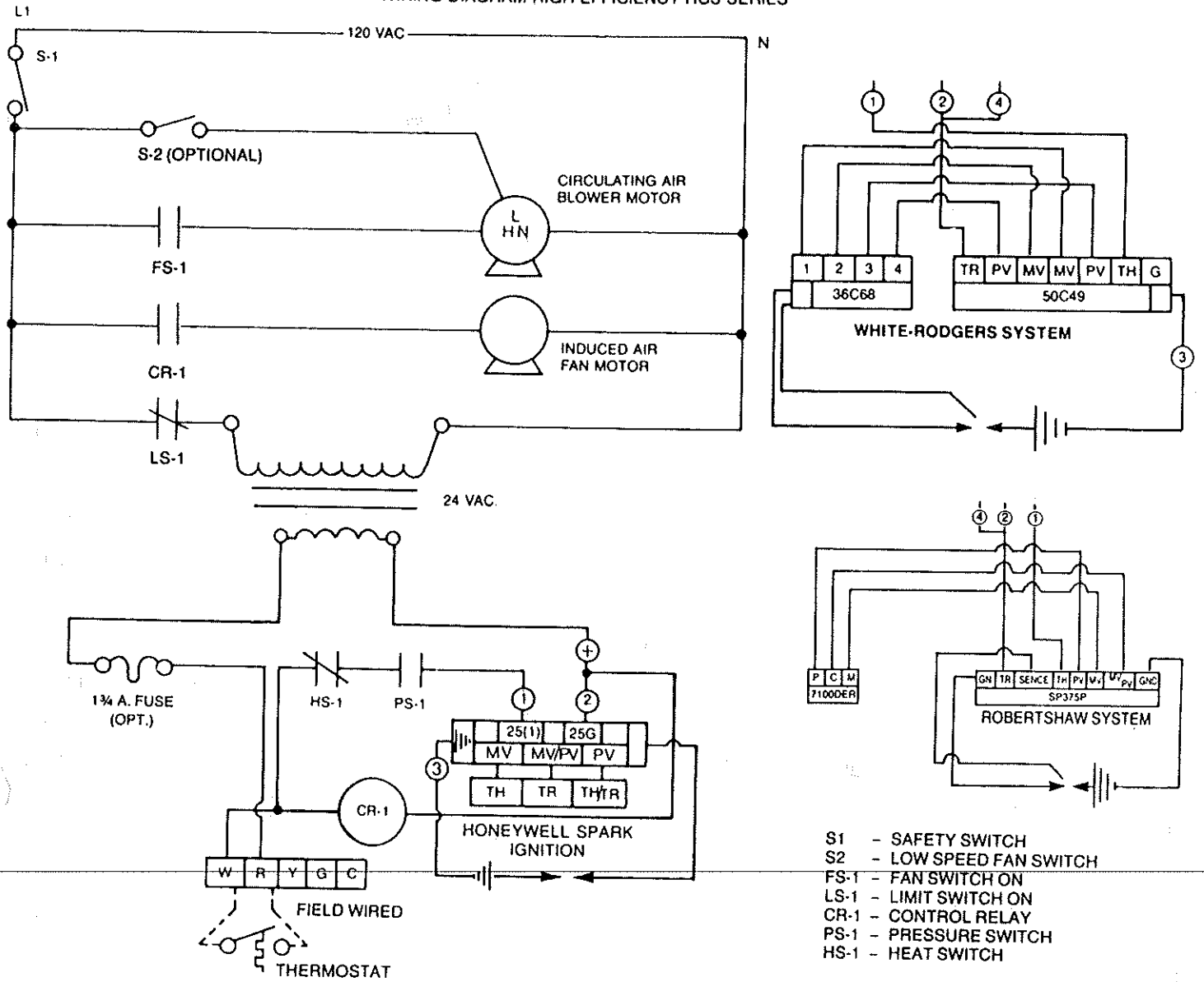

- S1 - SAFETY SWITCH
- S2 - LOW SPEED FAN SWITCH
- FS-1 - FAN SWITCH ON
- LS-1 - LIMIT SWITCH ON
- CR-1 - CONTROL RELAY
- PS-1 - PRESSURE SWITCH
- HS-1 - HEAT SWITCH

WIRING DIAGRAM

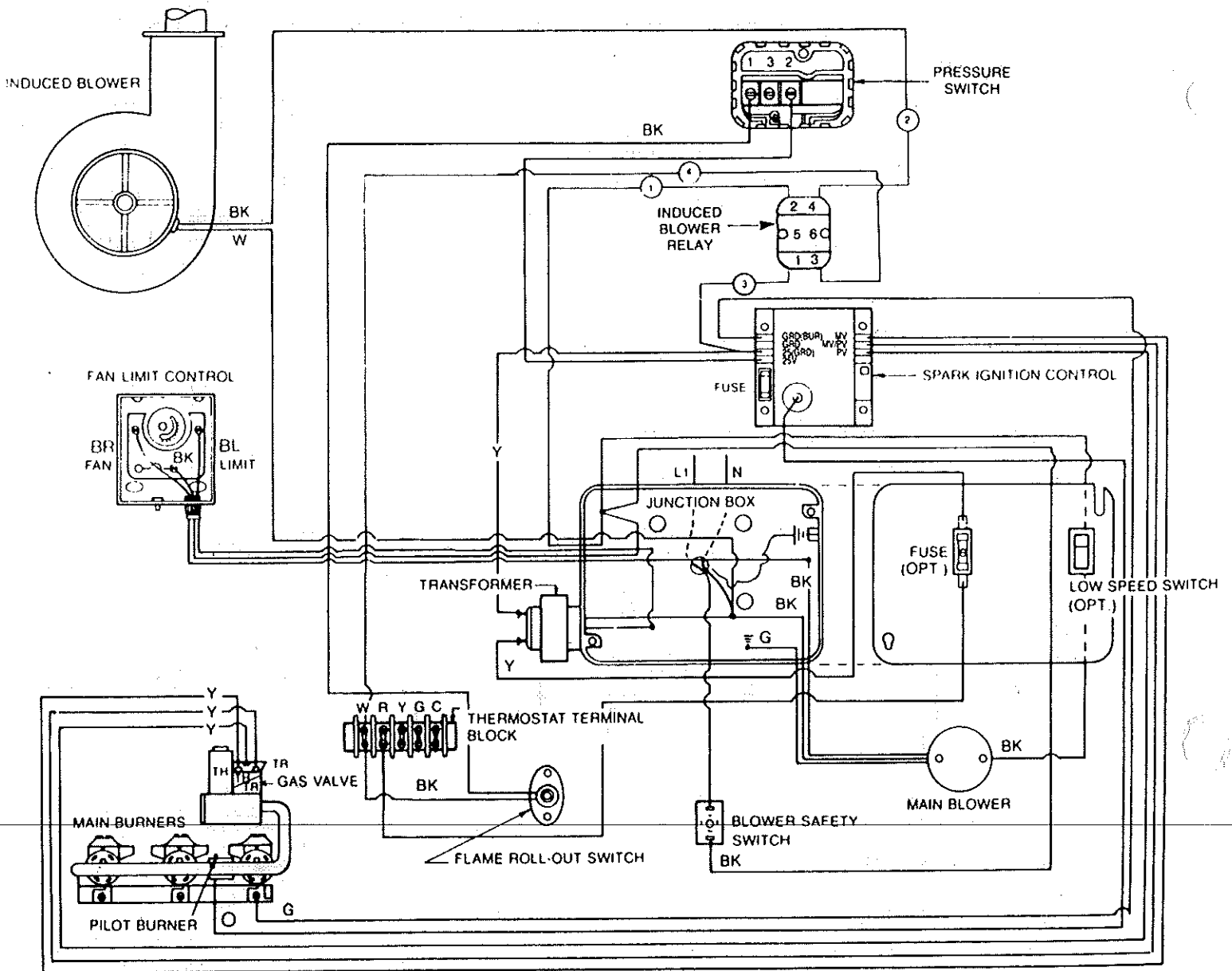

HONEYWELL WIRING SCHEMATIC

DUOMATIC-OLSEN ULTRAMAX CONDENSING FURNACE UPDATE

JULY, 1988

FURNACE CHANGES

This line of furnaces has been upgraded to the "Ultramax II" as well as taking on a new line called "Airco."

In this new line of "Ultramax II" furnaces there are internal, controls, and venting changes.

Inducer Motor--The new line of "Ultramax II" furnaces has a one piece plastic inducer motor housing.

Fan Motor--The new line of "Ultramax II" furnaces now have available a direct-drive multi-speed fan motor, as well as the belt-drive motors.

Condensate Drain--The new line of "Ultramax II" furnaces now have a condensate trap/vent drip leg assemble supplied with the furnace.

Heat Anticipator Setting--The heat anticipator should be set according to the current draw of the inducer draft blower and the ignition control (0.9 or more).

Ignition Systems--The new line of "Ultramax II" furnaces will now have available both spark ignition and the new White Rodgers hot surface ignition system.

SEQUENCE OF OPERATION FOR THE WHITE RODGERS HOT SURFACE IGNITION SYSTEM

1. Thermostat calls for heat.
2. Induced draft blower relay contacts close.
3. Induced draft blower starts.
4. When induced draft blower reaches near full RPM, pressure switch closes.
5. 45 second pre-purge and igniter warm up time is activated on HSI controller.
6. Once the igniter is fully warmed, both valves are opened and main burners will light.
7. System will remain in this state until the call for heat is satisfied.
8. Thermostat opens.
9. Induced draft blower relay opens, ignition control is de-energized closing main valves. The induced draft blower begins to coast to a stop.
10. As the induced draft blower slows down, the pressure switch will open.
11. The system will remain idle until the next call for heat.

NOTE: If flame is not established within the initial start up, the system will lockout. The ignition sequence will be repeated up to three times and a 60 second wait between each trail.

VENTING

The furnace must not be vented in common with any other appliance and it may not be connected to any portion of a factory built or masonry chimney.

A. MATERIAL

Schedule 40, PVC, or CPVC plastic pipe and fittings with a nominal inside diameter of 2" is recommended to be used.

WARNING: Due to the low temperatures of the combustion products, the moisture contained in the flue gases will condense when they meet with the cooler outdoor temperatures. This condensate is slightly acidic and may cause some discoloration of the building's exterior finish or may freeze on the building exterior. Follow these instructions closely to minimize the effect of the condensate on the structure.

B. VENT LENGTH

1. The maximum overall equivalent vent length for this unit is 60 feet. The minimum equivalent vent length is 20 feet.

2. FITTINGS:

A 90 degrees elbow is equivalent to ten feet of straight pipe.

A 45 degrees elbow is equivalent to five feet of straight pipe.

C. SLOPE OF VENTING:

The vent should be sloped upwards from the furnace a minimum of 1/4 inch per running foot to allow for

drainage of condensate in the vent.

D. PIPE SUPPORT

The vent should be adequately supported every three feet to prevent sagging. Plastic or rubber strapping is suggested to prevent vibration where it may be noticeable. The vent should not be attached directly to the floor beams.

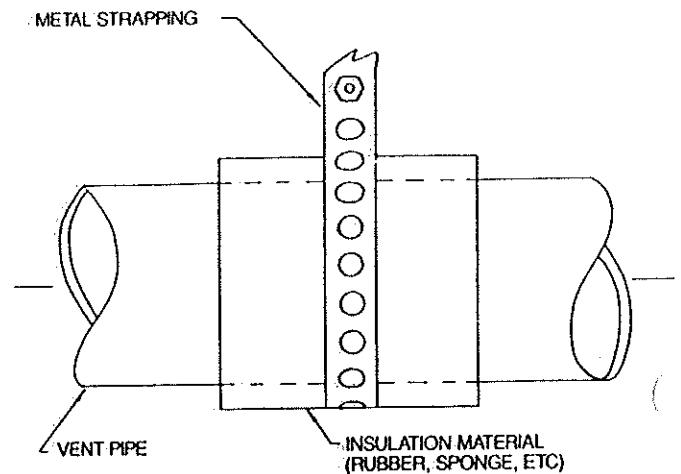

E. VENT TERMINATION

The vent may be terminated through the roof or through the wall using the vent terminal Tee supplied with the furnace. A wall riser kit is available from the furnace manufacturer.

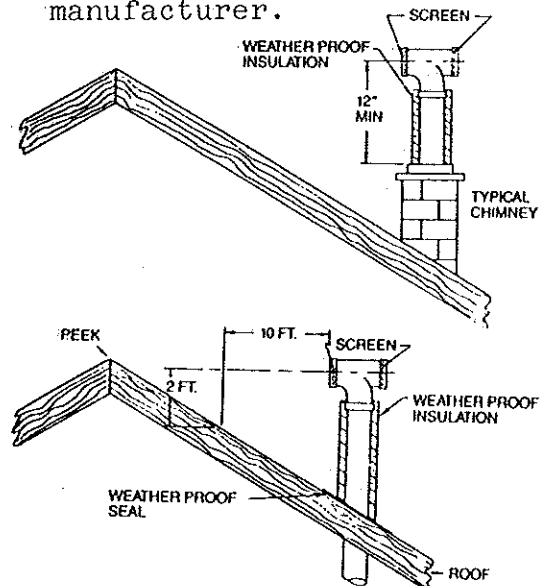

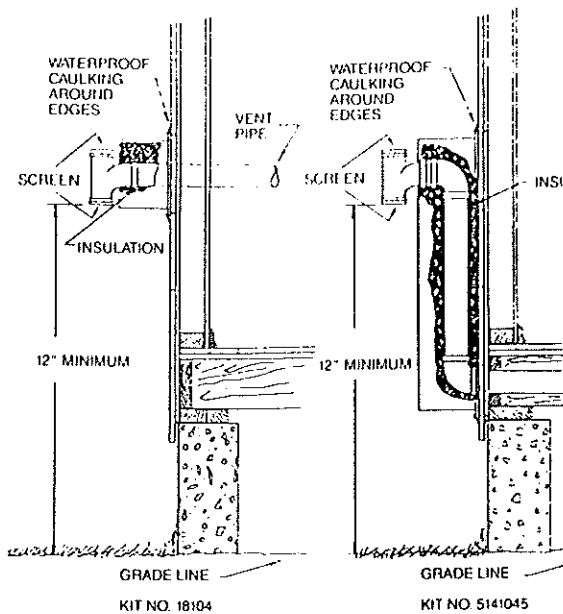
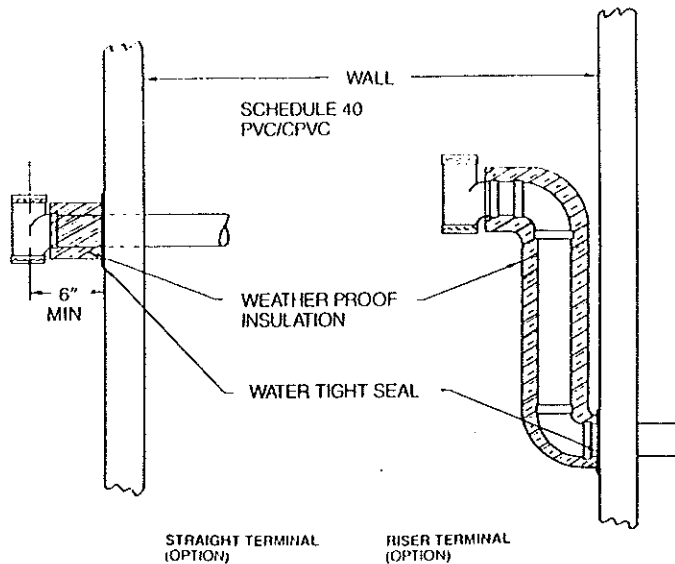

F. LOCATION OF VENT TERMINAL

1. The vent terminal must not be located:
 - a. less than three feet from the combustion air inlet of the furnace
 - b. less than six feet from a combustion air inlet of another appliance
 - c. less than three feet from any building opening

- d. directly above a gas meter or service regulator
- e. directly above a walkway unless 7" above grade

1. It is recommended that the vent terminal be located:
 - a. more than four feet below building soffit
 - b. more than four feet from an inside corner formed from two exterior walls
 - c. three feet above grade; one foot minimum above grade must be maintained
 - d. on the sides of the building which are not exposed to the prevailing winds
 - e. where it is accessible for maintenance and inspection

G. VENT INSULATION

Whenever the exhaust vent pipe is exposed to extreme weather conditions, insulation used must be of a weatherproof type suitable for outdoor use. If the insulation is not a weatherproof type then the exhaust vent pipe insulation must be enclosed in a suitable weatherproof enclosure to protect the insulation from the effects of the weather. A vent termination box is available from the manufacturer which is suitable to protect non-weather resistant insulation in most applications.

Whenever the exhaust vent pipe passes through an unheated space within a building, a suitable form of insulation must be wrapped and secured around the exhaust pipe.

H. VENT TESTING

All vent pipe connections should be checked for leaks with a soapy solution, the induced draft blower running and the outlet blocked. All leaking joints must be sealed and checked again.

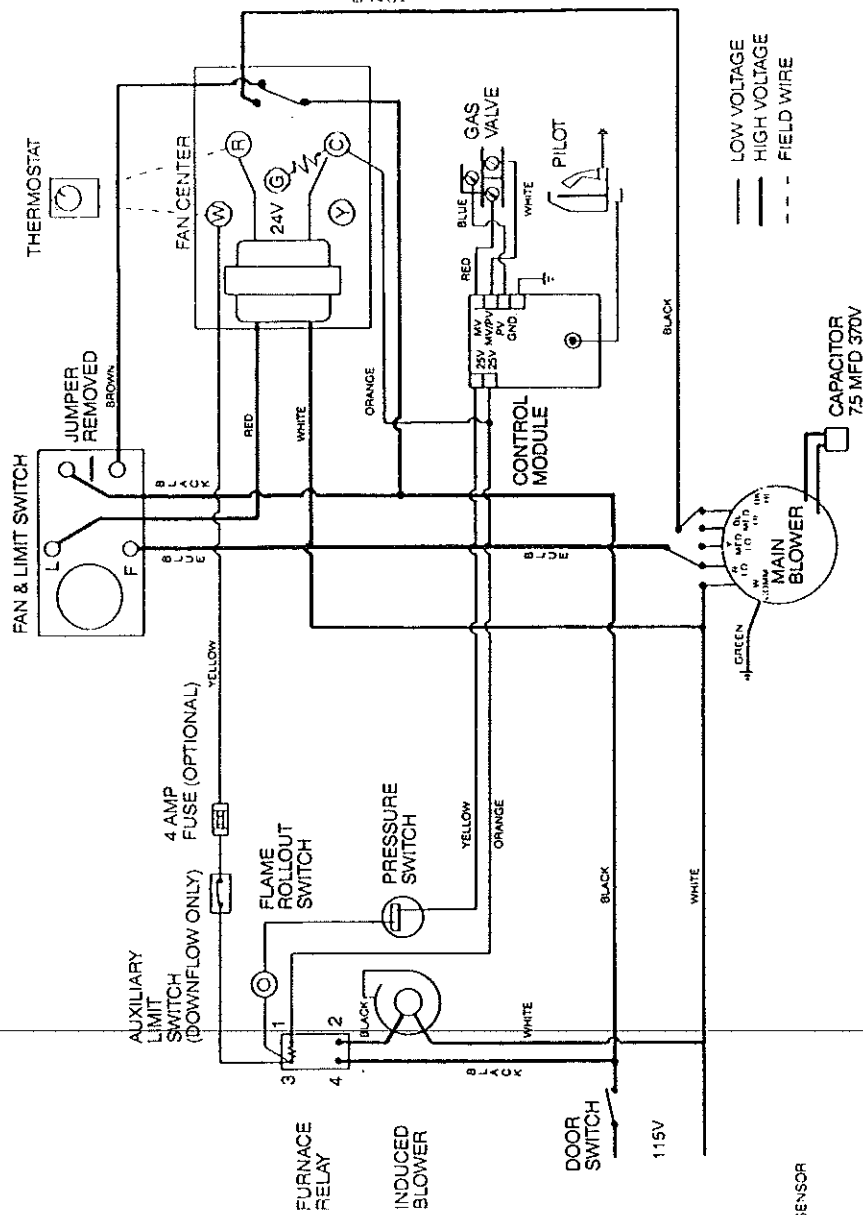
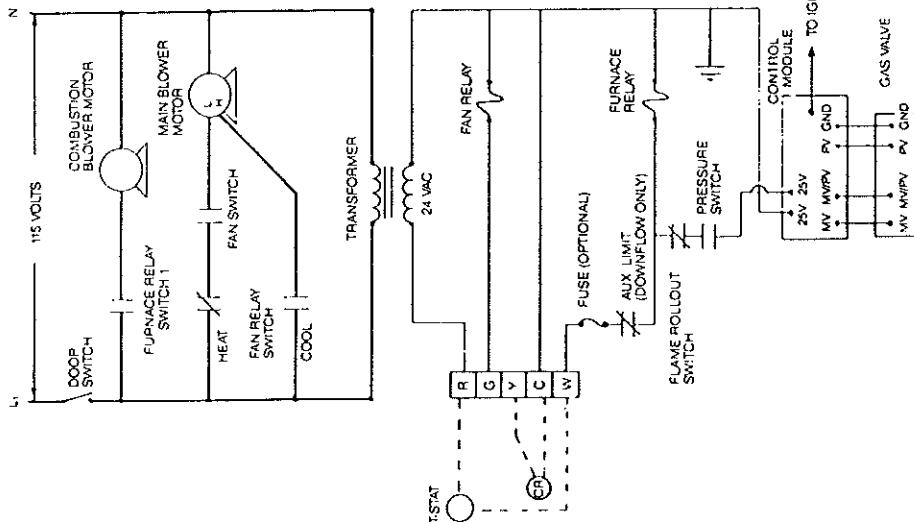

DIRECT DRIVE WIRING DIAGRAM

