

INSTALLATION INSTRUCTIONS

A95UH1E & 95G1UHE

Warm Air Gas Furnace

Upflow/Horizontal Left and Right Air Discharge



This manual must be left with the homeowner for future reference.



This is a safety alert symbol and should never be ignored. When you see this symbol on labels or in manuals, be alert to the potential for personal injury or death.

CAUTION

As with any mechanical equipment, personal injury can result from contact with sharp sheet metal edges. Be careful when you handle this equipment.

WARNING

Improper installation, adjustment, alteration, service or maintenance can cause property damage, personal injury or loss of life. Installation and service must be performed by a licensed professional installer (or equivalent), service agency or the gas supplier.

TABLE OF CONTENTS

Unit Dimensions	2	Vent Piping Guidelines	18
Parts Arrangement.....	3	Gas Piping.....	39
Gas Furnace.....	4	Electrical.....	42
Shipping and Packing List.....	4	Unit Start-Up.....	45
Safety Information	4	Gas Pressure Adjustment.....	47
Use of Furnace as a Construction Heater	5	High Altitude Information	47
General	6	Other Unit Adjustments.....	50
Combustion, Dilution & Ventilation Air	6	Blower Motor Performance.....	51
Setting Equipment	10	Service	53
Filters	14	Planned Service	55
Duct System.....	14	Diagnostic Codes	55
Pipe & Fittings Specifications.....	14	Repair Parts List.....	56
Joint Cementing Procedure.....	16	Start-Up & Performance Check List	57
Venting Practices.....	17		



(P) 507276-03

Manufactured By
Allied Air Enterprises LLC
A Lennox International, Inc. Company
215 Metropolitan Drive
West Columbia, SC 29170

A95UH1E & 95G1UHE Unit Dimensions - inches (mm)

1 NOTE - C20 and D20 (5 Ton) size units installed in upflow applications that require air volumes of 1800 cfm (850 L/s) or greater must have one of the following:

1. Single side return air with transition, to accommodate 20 x 25 x 1 in. (508 x 635 x 25 mm) cleanable air filter. (Required to maintain proper air velocity.)
2. Single side return air with optional "RAB" Return Air Base.
3. Bottom return air.
4. Return air from both sides.
5. Bottom and one side return air.

See "Blower Performance Tables" for additional information.

2 Optional External Side Return Air Filter kit is not for use with optional Return Air Base.

* Consider sizing requirements for optional IAQ equipment before cutting side return opening.

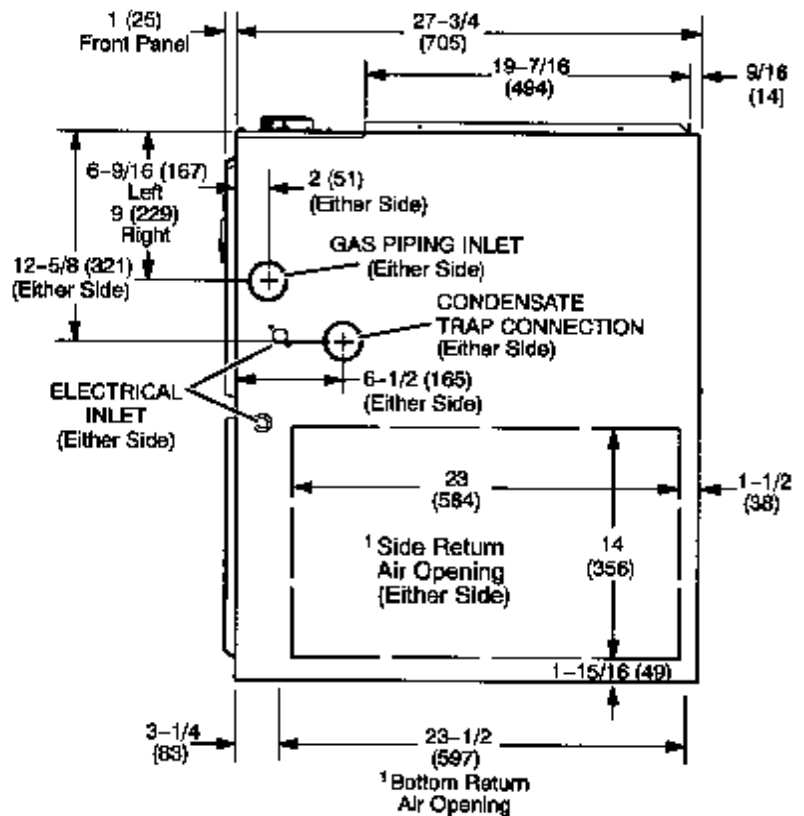
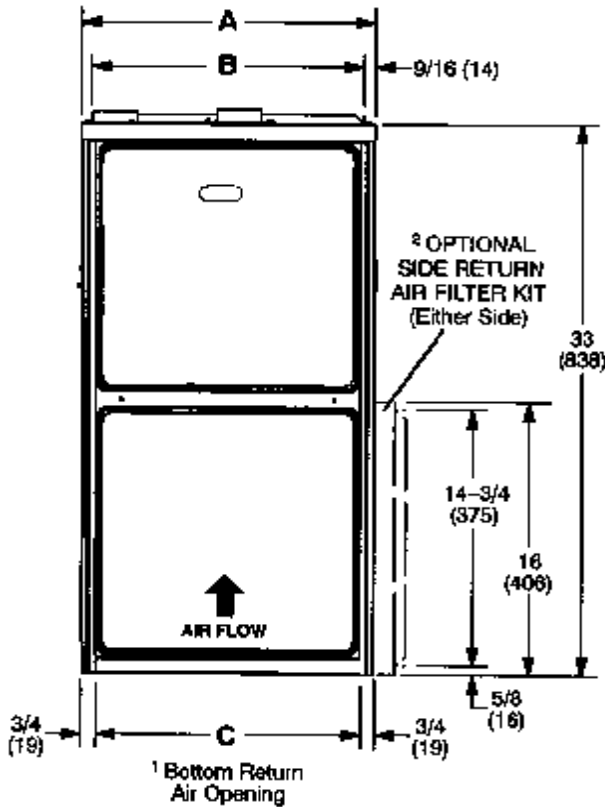
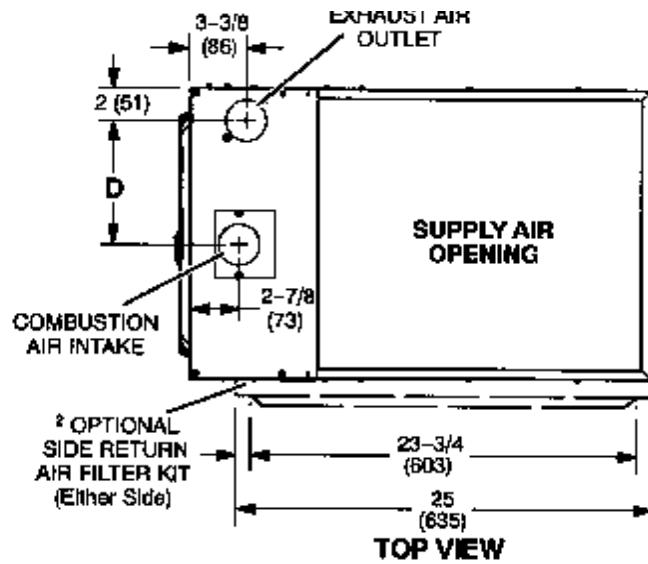

Model A95UH1E & 95G1UHE	A		B		C		D	
	in.	mm	in.	mm	in.	mm	in.	mm
030-08 045-08 045-12 070-08 070-12	17-1/2	446	16-3/8	416	16	406	7-5/8	194
090-12 090-16 110-12 110-16 110-20	21	533	19-7/8	505	19-1/2	495	9-3/8	238
135-20	24-1/2	622	23-3/8	594	23	584	11-1/8	283

EXPANDED VIEW

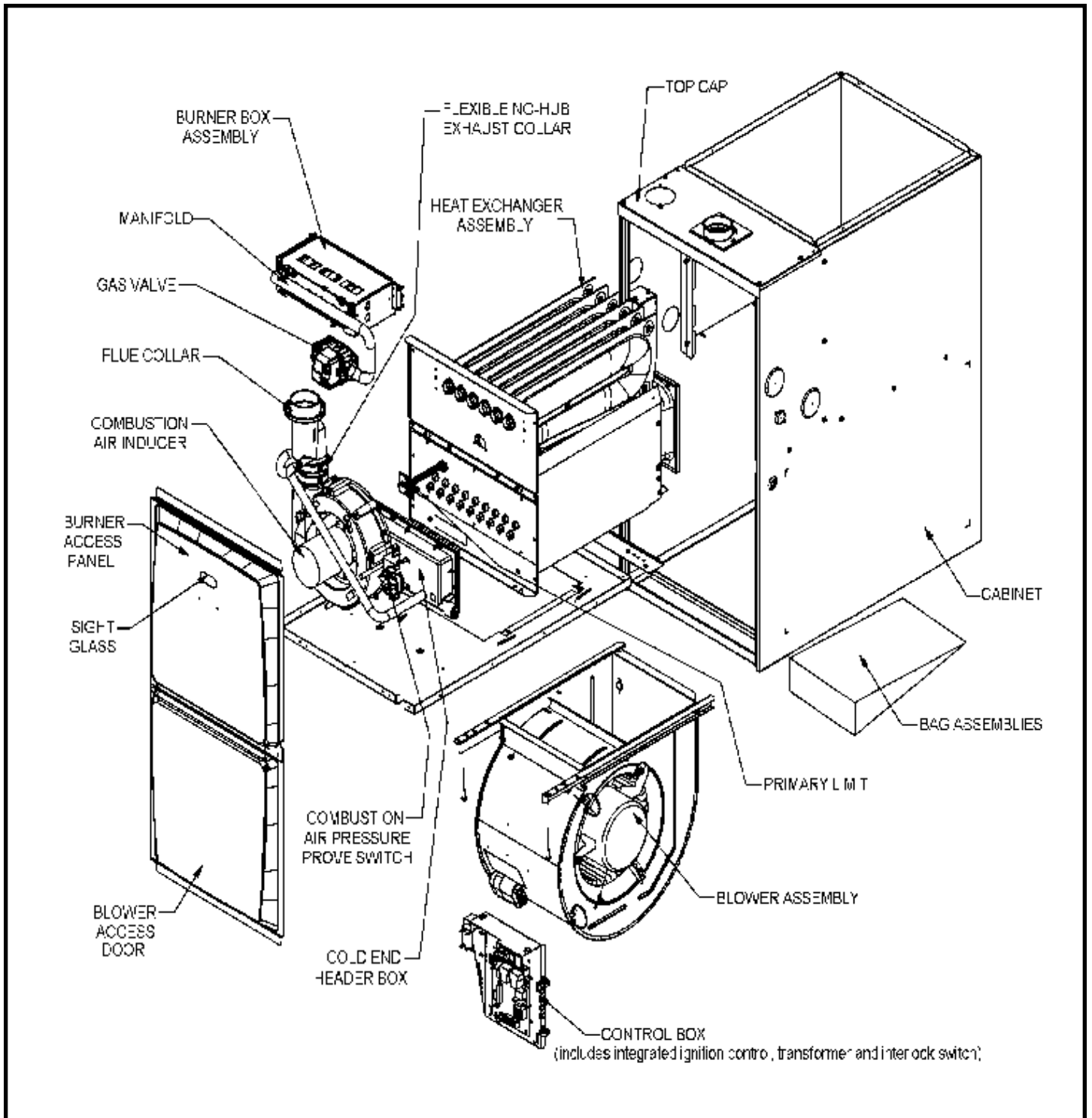

Figure 1

A95UH1E & 95G1UHE Gas Furnace

The A95UH1E and 95G1UHE Category IV gas furnace is shipped ready for installation in the upflow or horizontal position. The furnace is shipped with the bottom panel in place. The bottom panel must be removed if the unit is to be installed in horizontal or upflow applications with bottom return air.

The A95UH1E and 95G1UHE can be installed as either a Direct Vent or a Non-Direct Vent gas central furnace

The furnace is equipped for installation in natural gas applications. A conversion kit (ordered separately) is required for use in propane/LP gas applications.

NOTE: In Direct Vent installations, combustion air is taken from outdoors and flue gases are discharged outdoors. In Non-Direct Vent installations, combustion air is taken from indoors or ventilated attic or crawlspace and flue gases are discharged outdoors. See Figures 2 and 3 for applications involving roof termination.

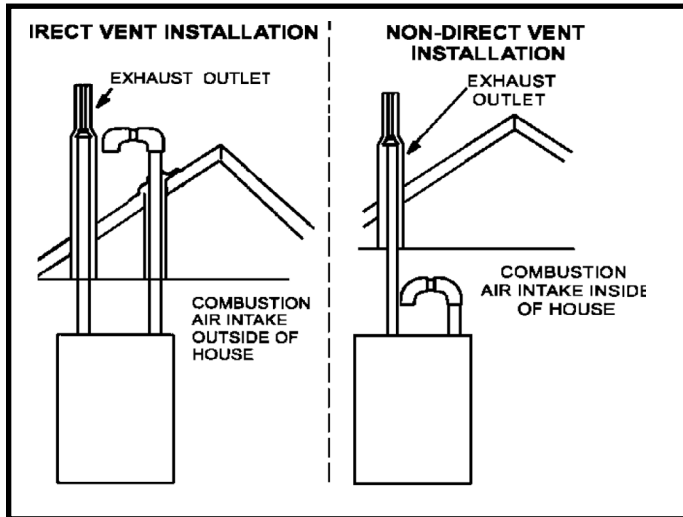

Figure 2

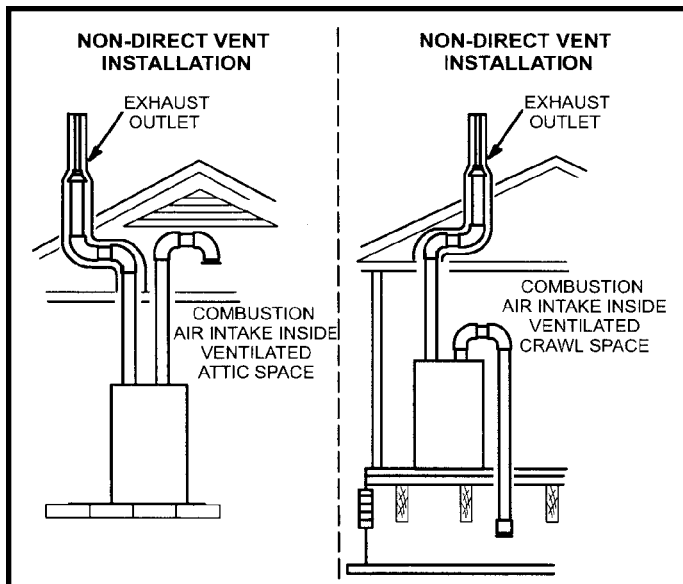

Figure 3

Shipping and Packing List

- 1 - Assembled Gas Furnace
- 1 - Bag assembly containing the following:
 - 1 - Snap bushing
 - 1 - Snap Plug
 - 1 - Wire tie
 - 1 - Condensate trap
 - 1 - Condensate trap cap
 - 1 - Condensate trap clamp
 - 1 - 2" diameter debris screen
 - 1 - 3/4" Threaded street elbow

Check equipment for shipping damage. If you find any damage, immediately contact the last carrier.

Please refer to specification sheets for available accessories.

Safety Information

WARNING

Improper installation, adjustment, alteration, service or maintenance can cause property damage, personal injury or loss of life. Installation and service must be performed by a licensed professional installer (or equivalent), service agency or the gas supplier.

CAUTION

As with any mechanical equipment, personal injury can result from contact with sharp sheet metal edges. Be careful when you handle this equipment.

DANGER

DANGER OF EXPLOSION!

There are circumstances in which odorant used with LP/Propane gas can lose its scent. In case of a leak, LP/Propane gas will settle close to the floor and may be difficult to smell. An LP/Propane leak detector should be installed in all LP applications.

Use only the type of gas approved for use with this furnace. Refer to unit nameplate.

A95UH1E & 95G1UHE units are CSA International certified to ANSI Z21.47 and CSA 2.3 standards.

Building Codes

In the USA, installation of gas furnaces must conform with local building codes. In the absence of local codes, units must be installed according to the current National Fuel Gas Code (ANSI Z223.1/NFPA 54). The National Fuel Gas Code is available from the **American National Standards Institute, Inc., 11 West 42nd Street, New York, NY 10036.**

In Canada, installation must conform with current National Standard of Canada CSA-B149 Natural Gas and Propane Installation Codes, local plumbing or waste water codes and other applicable local codes.

In order to ensure proper unit operation in non-direct vent applications, combustion and ventilation air supply must be provided according to the current National Fuel Gas Code or CSA-B149 standard.

Installation Locations

This furnace is CSA International certified for installation clearances to combustible material as listed on the unit nameplate and in the table in Figure 13 and 18. Accessibility and service clearances must take precedence over fire protection clearances.

NOTE: For installation on combustible floors, the furnace shall not be installed directly on carpeting, tile, or other combustible material other than wood flooring.

For installation in a residential garage, the furnace must be installed so that the burner(s) and the ignition source are located no less than 18 inches (457 mm) above the floor. The furnace must be located or protected to avoid physical damage by vehicles. When a furnace is installed in a public garage, hangar, or other building that has a hazardous atmosphere, the furnace must be installed according to recommended good practice requirements and current National Fuel Gas Code or CSA B149 standards.

NOTE: Furnace must be adjusted to obtain a temperature rise within the range specified on the unit nameplate. Failure to do so may cause erratic limit operation and premature heat exchanger failure.

This furnace must be installed so that its electrical components are protected from water.

Installed in Combination with a Cooling Coil

When this furnace is used with cooling units (Figure 4), it shall be installed in parallel with, or on the upstream side of, cooling units to avoid condensation in the heating compartment. With a parallel flow arrangement, a damper (or other means to control the flow of air) must adequately prevent chilled air from entering the furnace. If the damper is manually operated, it must be equipped to prevent operation of either the heating or the cooling unit, unless it is in the full **HEAT** or **COOL** setting.

When installed, this furnace must be electrically grounded according to local codes. In addition, in the United States, installation must conform with the current National Electric Code, ANSI/NFPA No. 70. The National Electric Code (ANSI/NFPA No. 70) is available from the following address:

National Fire Protection Association
 1 Battery March Park
 Quincy, MA 02269

In Canada, all electrical wiring and grounding for the unit must be installed according to the current regulations of the Canadian Electrical Code Part I (CSA Standard C22.1) and/or local codes.

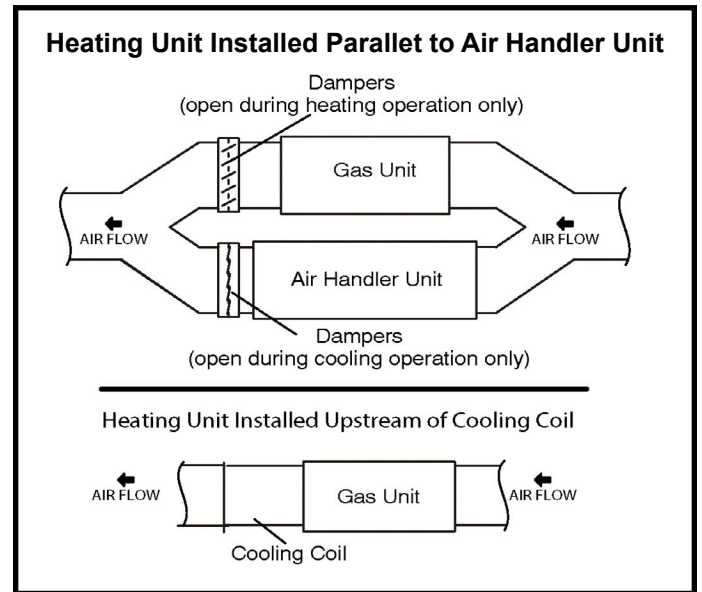

Figure 4

NOTE: This furnace is designed for a minimum continuous return air temperature of 60°F (16°C) or an intermittent operation down to 55°F (13°C) dry bulb for cases where a night setback thermostat is used. Return air temperature must not exceed 85°F (29°C) dry bulb.

This furnace may be installed in alcoves, closets, attics, basements, garages, and utility rooms in the upflow or horizontal position.

This furnace design has not been CSA certified for installation in mobile homes, recreational vehicles, or outdoors.

Use of Furnace as a Construction Heater

These units are not recommended for use as a construction heater during any phase of construction. Very low return air temperature, harmful vapors and operation of the unit with clogged or misplaced filters will damage the unit.

These units may be used for heating of buildings or structures under construction, if the following conditions are met:

- The vent system must be permanently installed per these installation instructions.
- A room thermostat must control the furnace. The use of fixed jumpers that will provide continuous heating is not allowed.
- The return air duct must be provided and sealed to the furnace.
- Return air temperature range between 60°F (16°C) and 80°F (27°C) must be maintained.
- Air filters must be installed in the system and must be maintained during construction.
- Air filters must be replaced upon construction completion.

- The input rate and temperature rise must be set per the furnace rating plate.
- One hundred percent (100%) outdoor air must be provided for combustion air requirements during construction. Temporary ducting may supply outdoor air to the furnace. Do not connect duct directly to the furnace. Size the temporary duct following the instructions in section for Combustion, Dilution and Ventilation Air in a confined space with air from outside.
- The furnace heat exchanger, components, duct system, air filters and evaporator coils must be thoroughly cleaned following final construction cleanup.
- All furnace operating conditions (including ignition, input rate, temperature rise and venting) must be verified according to these installation instructions.

General

These instructions are intended as a general guide and do not supersede local codes in any way. Consult authorities having jurisdiction before installation.

In addition to the requirements outlined previously, the following general recommendations must be considered when installing one of these furnaces:

- Place the furnace as close to the center of the air distribution system as possible. The furnace should also be located close to the vent termination point.
- When the furnace is installed in non-direct vent applications, do not install the furnace where drafts might blow directly into it. This could cause improper combustion and unsafe operation.
- When the furnace is installed in non-direct vent applications, do not block the furnace combustion air opening with clothing, boxes, doors, etc. Air is needed for proper combustion and safe unit operation.
- When the furnace is installed in an attic or other insulated space, keep insulation away from the furnace.
- When the furnace is installed in an unconditioned space, consider provisions required to prevent freezing of condensate drain system.

NOTE: *The Commonwealth of Massachusetts stipulates these additional requirements:*

- Gas furnaces shall be installed by a licensed plumber or fitter only.
- The gas cock must be "T handle" type.
- When a furnace is installed in an attic, the passageway to and service area surrounding the equipment shall be floored.

CAUTION

These units should not be installed in areas normally subject to freezing temperatures.

WARNING

The State of California has determined that this product may contain or produce a chemical or chemicals, in very low doses, which may cause serious illness or death. It may also cause cancer, birth defects or other reproductive harm.

Combustion, Dilution & Ventilation Air

If this unit is installed as a Non-Direct Vent Furnace, follow the guidelines in this section.

NOTE: *In Non-Direct Vent Installations, combustion air is taken from indoors and flue gases are discharged outdoors.*

WARNING

Insufficient combustion air can cause headaches, nausea, dizziness or asphyxiation. It will also cause excess water in the heat exchanger resulting in rusting and premature heat exchanger failure. Excessive exposure to contaminated combustion air will result in safety and performance related problems. Avoid exposure to the following substances in the combustion air supply:

- Permanent wave solutions
- Chlorinated waxes and cleaners
- Chlorine base swimming pool chemicals
- Water softening chemicals
- De-icing salts or chemicals
- Carbon tetrachloride
- Halogen type refrigerants
- Cleaning solvents (such as perchloroethylene)
- Printing inks, paint removers, varnishes, etc.
- Hydrochloric acid
- Cements and glues
- Antistatic fabric softeners for clothes dryers
- Masonry acid washing materials

In the past, there was no problem in bringing in sufficient outdoor air for combustion. Infiltration provided all the air that was needed. In today's homes, tight construction practices make it necessary to bring in air from outside for combustion. Take into account that exhaust fans, appliance vents, chimneys, and fireplaces force additional air that could be used for combustion out of the house. Unless outside

air is brought into the house for combustion, negative pressure (outside pressure is greater than inside pressure) will build to the point that a down draft can occur in the furnace vent pipe or chimney. As a result, combustion

gases enter the living space creating a potentially dangerous situation.

In the absence of local codes concerning air for combustion and ventilation, use the guidelines and procedures in this section to install these furnaces to ensure efficient and safe operation. You must consider combustion air needs and requirements for exhaust vents and gas piping. A portion of this information has been reprinted with permission from the National Fuel Gas Code (ANSI-Z223.1/NFPA 54). This reprinted material is not the complete and official position of ANSI on the referenced subject, which is represented only by the standard in its entirety.

In Canada, refer to the CSA B149 Installation codes. All gas-fired appliances require air for the combustion process. If sufficient combustion air is not available, the furnace or other appliance will operate inefficiently and unsafely. Enough air must be provided to meet the needs of

CAUTION

Do not install the furnace in a corrosive or contaminated atmosphere. Meet all combustion and ventilation air requirements, as well as all local codes.

all fuel-burning appliances and appliances such as exhaust fans which force air out of the house. When fireplaces, exhaust fans, or clothes dryers are used at the same time as the furnace, much more air is required to ensure proper combustion and to prevent a down draft. Insufficient air causes incomplete combustion which can result in carbon monoxide.

In addition to providing combustion air, fresh outdoor air dilutes contaminants in the indoor air. These contaminants may include bleaches, adhesives, detergents, solvents and other contaminants which can corrode furnace components.

The requirements for providing air for combustion and ventilation depend largely on whether the furnace is installed in an unconfined or a confined space.

Unconfined Space

An unconfined space is an area such as a basement or large equipment room with a volume greater than 50 cubic feet (1.42 m³) per 1,000 Btu (.29 kW) per hour of the combined input rating of all appliances installed in that space. This space also includes adjacent rooms which are not separated by a door. Though an area may appear to be unconfined, it might be necessary to bring in outdoor air for combustion if the structure does not provide enough air by infiltration. If the furnace is located in a building of tight construction with weather stripping and caulking around the windows and doors, follow the procedures in the “Air from Outside” section.

one 90° elbow. The minimum length certified for use with this furnace is 5' and one elbow, not including the vent and air intake terminals.

infiltration. If the furnace is located in a building of tight construction with weather stripping and caulking around the windows and doors, follow the procedures in the “Air from Outside” section.

Confined Space

A confined space is an area with a volume less than 50 cubic feet (1.42 m³) per 1,000 Btu (.29 kW) per hour of the combined input rating of all appliances installed in that space. This definition includes furnace closets or small equipment rooms.

When the furnace is installed so that supply ducts carry air circulated by the furnace to areas outside the space containing the furnace, the return air **must be** handled by ducts which are sealed to the furnace casing and which terminate outside the space containing the furnace. This is especially important when the furnace is mounted on a platform in a confined space such as a closet or small equipment room. Even a small leak around the base of the unit at the platform or at the return air duct connection can cause a potentially dangerous negative pressure condition. Air for combustion and ventilation can be brought into the confined space either from inside the building or from outside.

Air from Inside

If the confined space that houses the furnace adjoins a space categorized as unconfined, air can be brought in by providing two permanent openings between the two spaces. Each opening must have a minimum free area of 1 square inch (645 mm²) per 1,000 Btu (.29 kW) per hour of total input rating of all gas-fired equipment in the confined space. Each opening must be at least 100 square inches (64516 mm²). One opening shall be within 12 inches (305 mm) of the top of the enclosure and one opening within 12 inches (305 mm) of the bottom. See Figure 5.

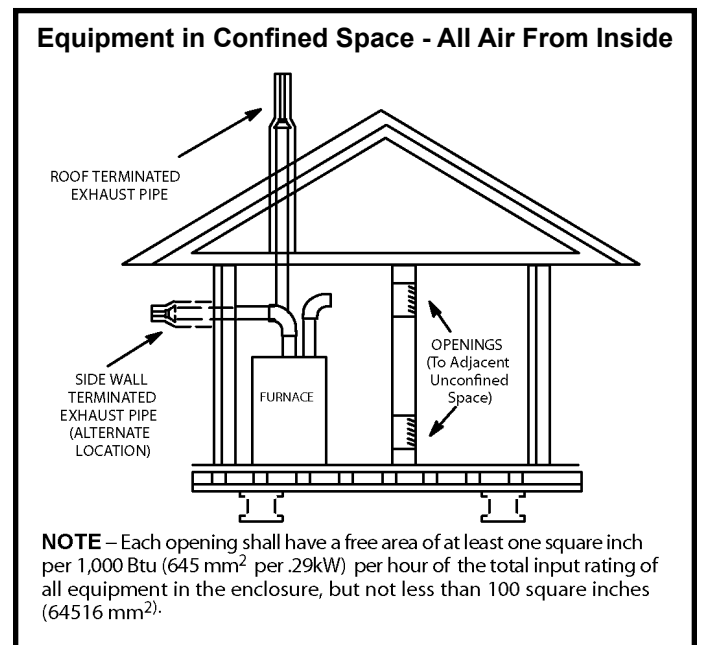

Figure 5

Air from Outside

If air from outside is brought in for combustion and ventilation, the confined space shall be provided with two permanent openings. One opening shall be within 12" (305 mm) of the top of the enclosure and one within 12" (305 mm) of the bottom. These openings must communicate directly or by ducts with the outdoors or spaces (crawl or attic) that freely communicate with the outdoors or indirectly through vertical ducts. Each opening shall have a minimum free area of 1 square inch per 4,000 Btu (645 mm² per .59 kW) per hour of the total input rating of all equipment in the enclosure (See Figures 6 and 7). It is also permissible to bring in air for combustion from a ventilated attic (Figure 9) or ventilated crawl space (Figure 10).

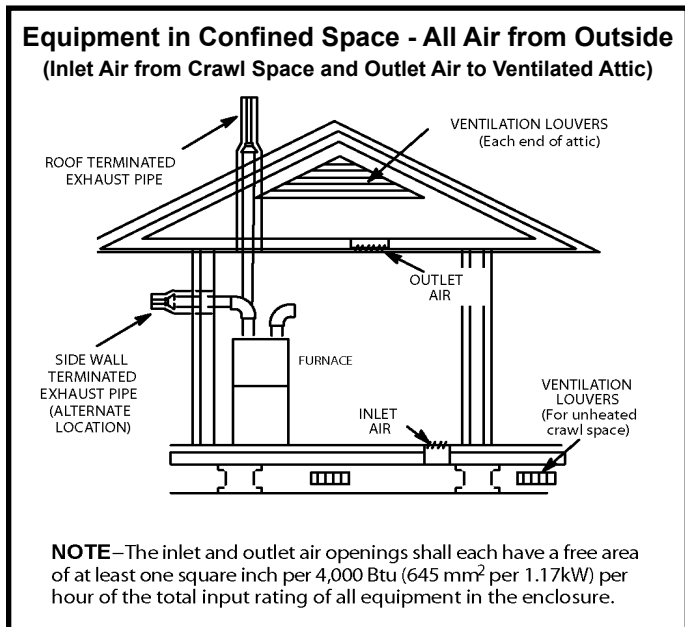

Figure 6

When communicating with the outdoors through horizontal ducts, each opening shall have a minimum free area of 1 square inch (645 mm²) per 2,000 Btu (.56 kW) per hour of the total input rating of all equipment in the enclosure. See Figure 8.

When ducts are used, they shall be of the same cross-sectional area as the free area of the openings to which they connect. The minimum dimension of rectangular air ducts shall be no less than 3 inches (75 mm). In calculating free area, the blocking effect of louvers, grilles, or screens must be considered. If the design and free area of protective covering is not known for calculating the size opening required, it may be assumed that wood louvers will have 20 to 25 percent free area and metal louvers and grilles will have 60 to 75 percent free area. Louvers and grilles must be fixed in the open position or interlocked with the equipment so that they are opened automatically during equipment operation.

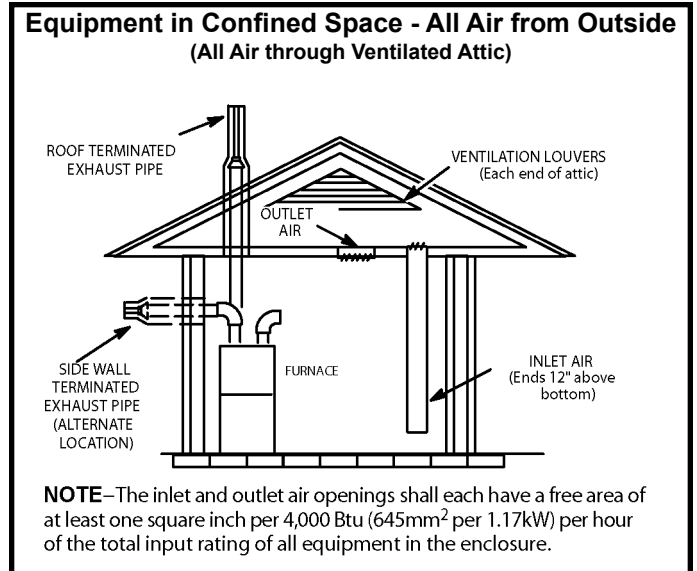

Figure 7

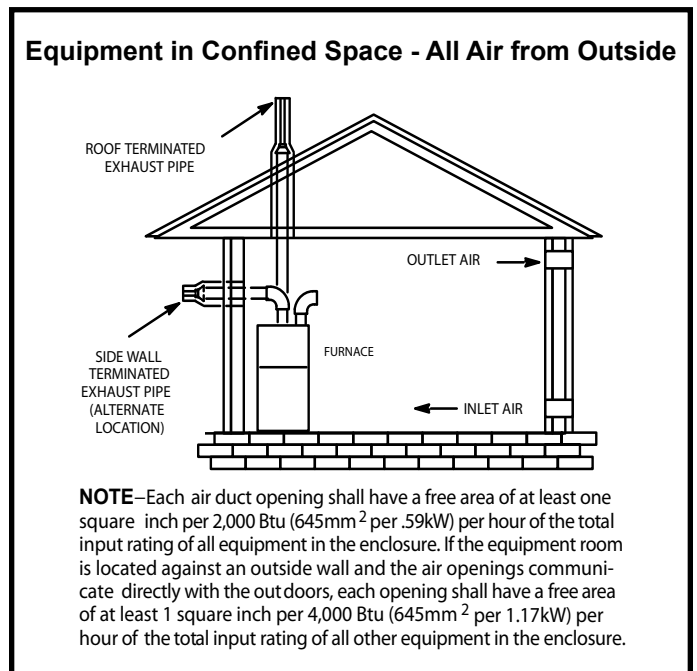

Figure 8

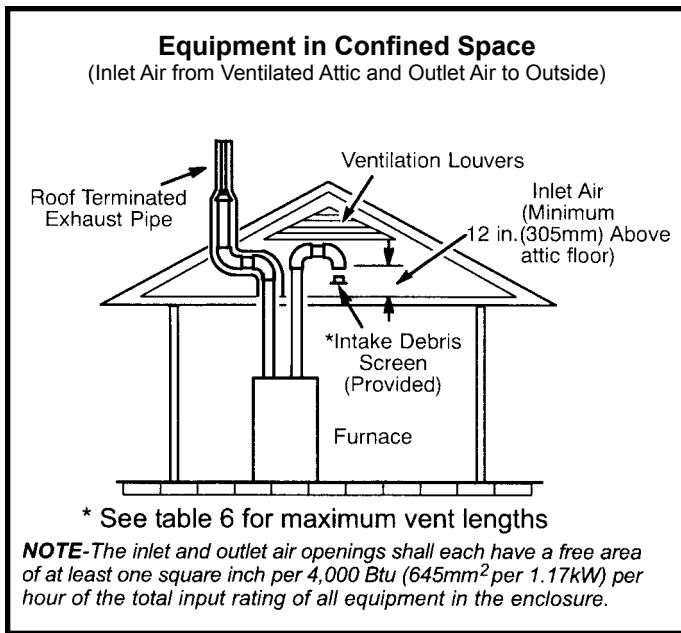

Figure 9

Shipping Bolt Removal

Units with 1/2 hp & 3/4 hp blower motor are equipped with three flexible legs and one rigid leg. The rigid leg is equipped with a shipping bolt and a flat white plastic washer (rather than the rubber mounting grommet used with a flexible mounting leg). See Figure 11. **The bolt and washer must be removed before the furnace is placed into operation.** After the bolt and washer have been removed, the rigid leg will not touch the blower housing.

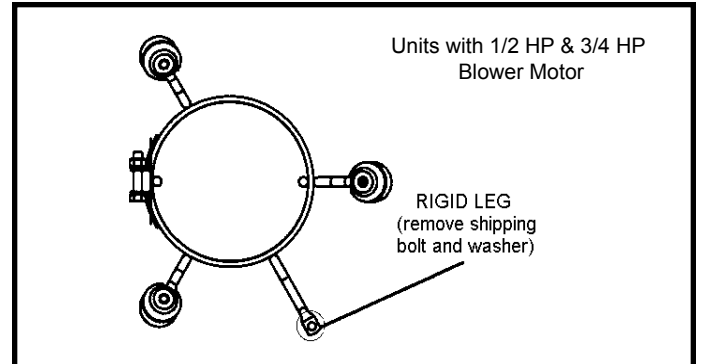

Figure 11

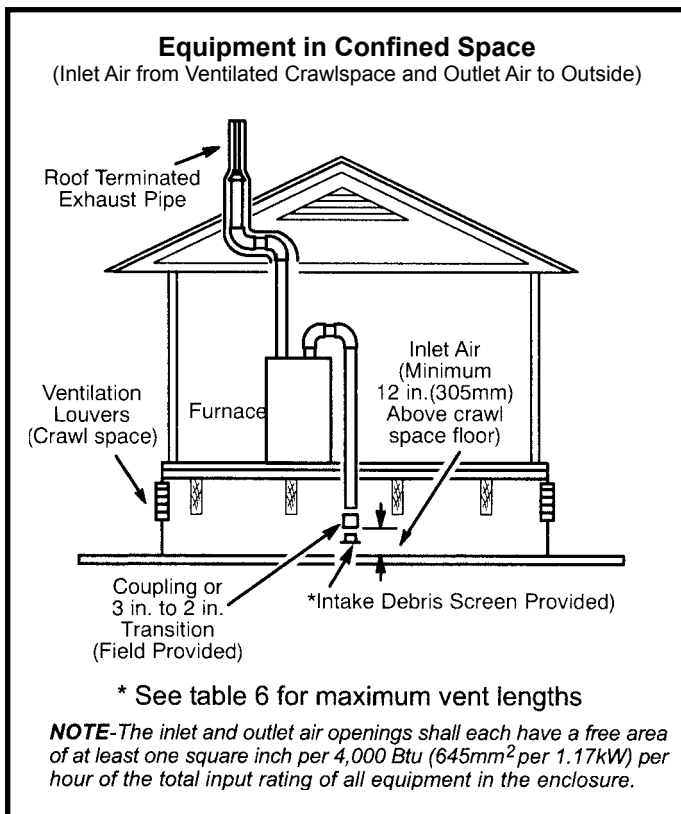

Figure 10

INSTALLATION
Setting Equipment

⚠ WARNING

Do not connect the return air ducts to the back of the furnace. Doing so will adversely affect the operation of the safety control devices, which could result in personal injury or death.

⚠ WARNING

Blower access panel must be securely in place when blower and burners are operating. Gas fumes, which could contain carbon monoxide, can be drawn into living space resulting in personal injury or death.

Upflow Applications

The gas furnaces can be installed as shipped in the upflow position. Refer to Figure 13 for clearances. Select a location that allows for the required clearances that are listed on the unit nameplate. Also consider gas supply connections, electrical supply, vent connection, condensate trap and drain connections, and installation and service clearances [24 inches (610 mm) at unit front]. **The unit must be level from side to side. Tilt the unit slightly (maximum 1/2 in. from level) from back to front to aid in the draining of the heat exchanger.** See Figure 12.

Allow for clearances to combustible materials as indicated on the unit nameplate.

Setting Equipment

Unit must be level side-to-side in all applications.

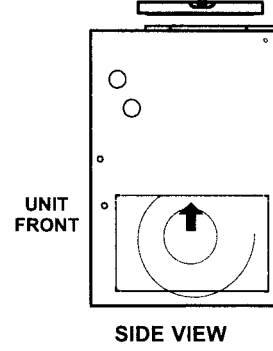
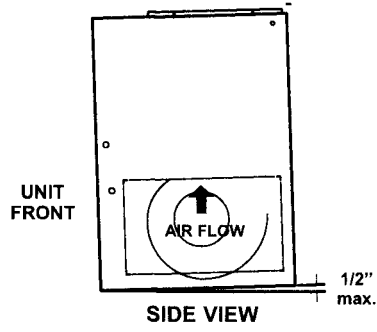
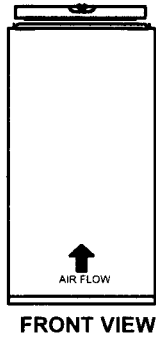

HORIZONTAL APPLICATION

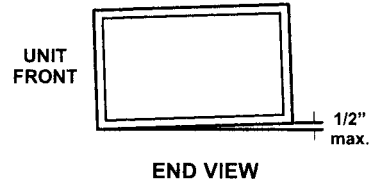
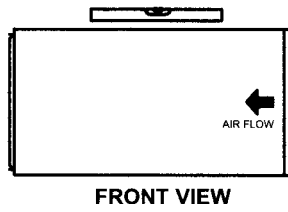

Tilt the unit slightly (Max. 1/2") from back to front to aid in the draining of the heat exchanger.

Figure 12

WARNING

Improper installation of the furnace can result in personal injury or death. Combustion and flue products must never be allowed to enter the return air system or air in the living space. Use sheet metal screws and joint tape to seal return air system to furnace.

In platform installations with furnace return, the furnace should be sealed airtight to the return air plenum. A door must never be used as a portion of the return air duct system. The base must provide a stable support and an airtight seal to the furnace. Allow absolutely no sagging, cracks, gaps, etc.

For no reason should return and supply air duct systems ever be connected to or from other heating devices such as a fireplace or stove, etc. Fire, explosion, carbon monoxide poisoning, personal injury and/or property damage could result.

Installation Clearances

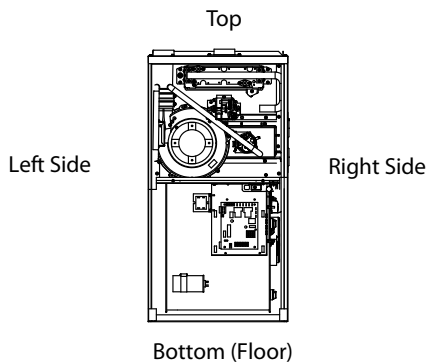

Top/Plenum	1 in. (25 mm)
*Front	0
Back	0
Sides	0†
Vent	0
Floor	0‡

*Front clearance in alcove installation must be 24 in. (610 mm). Maintain a minimum of 24 in. (610 mm) for front service access.
 †Allow proper clearances to accommodate condensate trap.
 ‡For installations on a combustible floor, do not install the furnace directly on carpeting, tile or other combustible materials other than wood flooring.

Figure 13

Return Air Guidelines

Return air can be brought in through the bottom or either side of the furnace installed in an upflow application. If the furnace is installed on a platform with bottom return, make an airtight seal between the bottom of the furnace and the platform to ensure that the furnace operates properly and safely. The furnace is equipped with a removable bottom panel to facilitate installation.

Markings are provided on both sides of the furnace cabinet for installations that require side return air. Cut the furnace cabinet at the maximum dimensions shown on page 2.

Furnace applications which include side return air and a condensate trap installed on the same side of the cabinet (trap can be installed remotely within 5 ft.) require either a return air base or field-fabricated transition to accommodate an optional IAQ accessory taller than 14.5". See Figure 14.

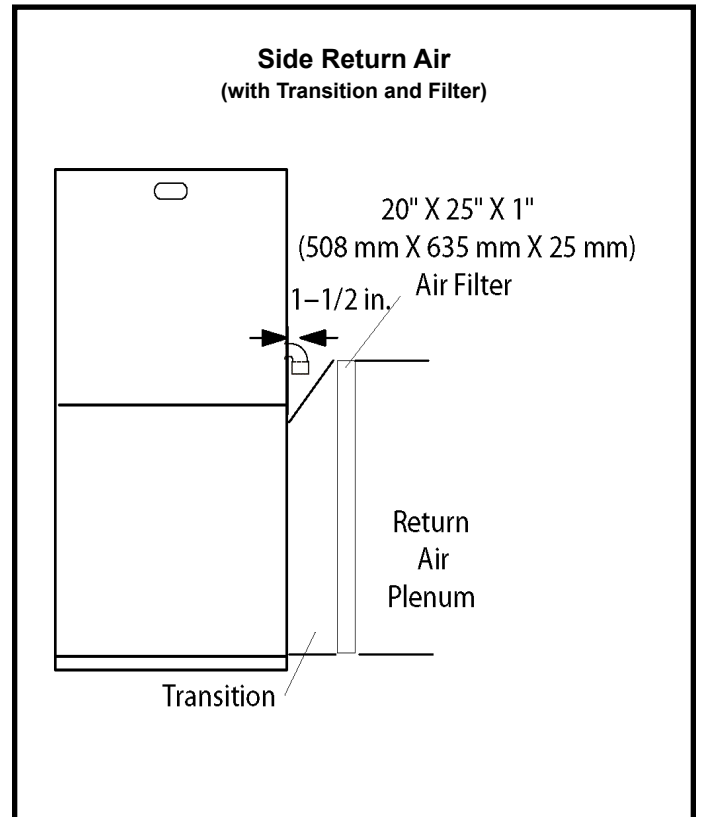

Figure 14

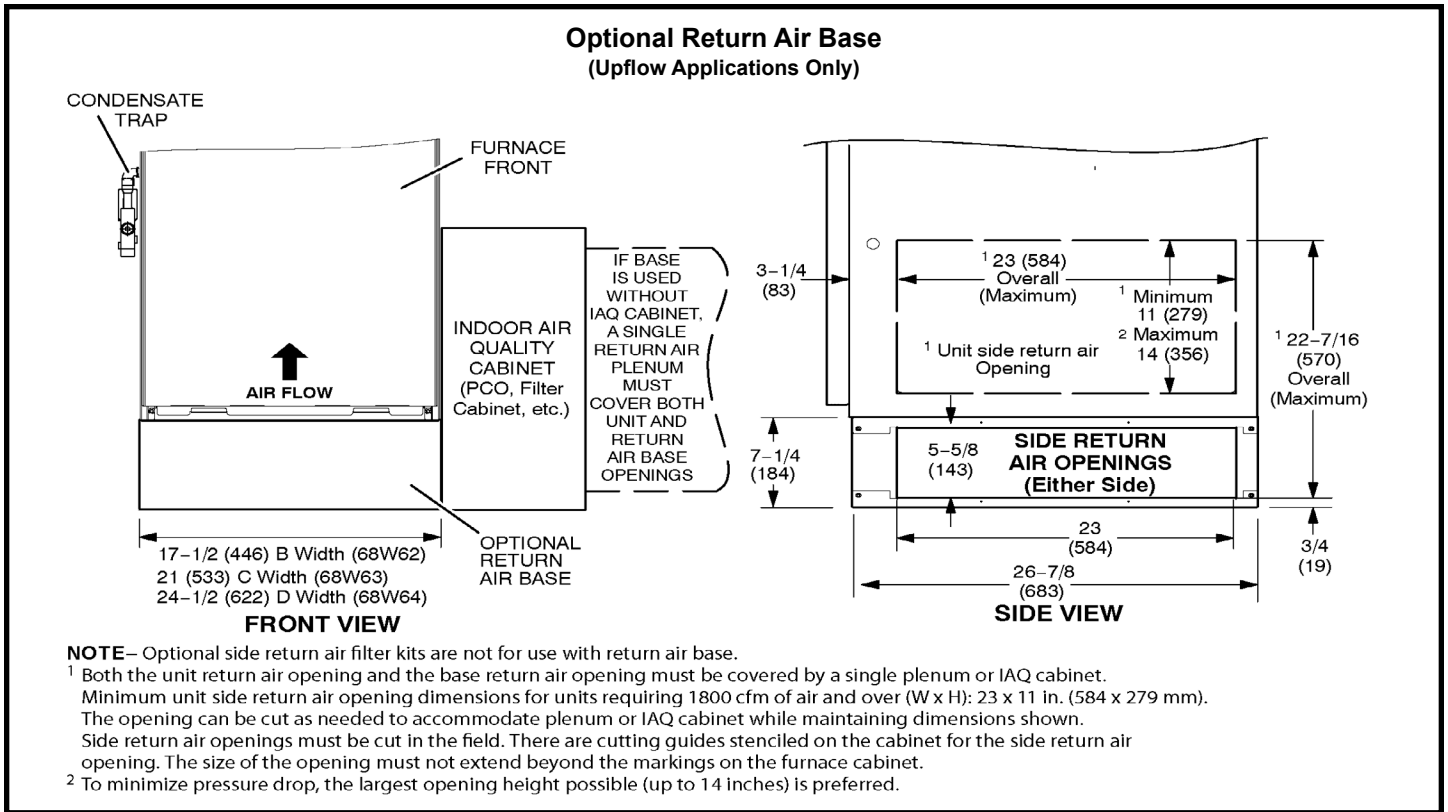

Figure 15

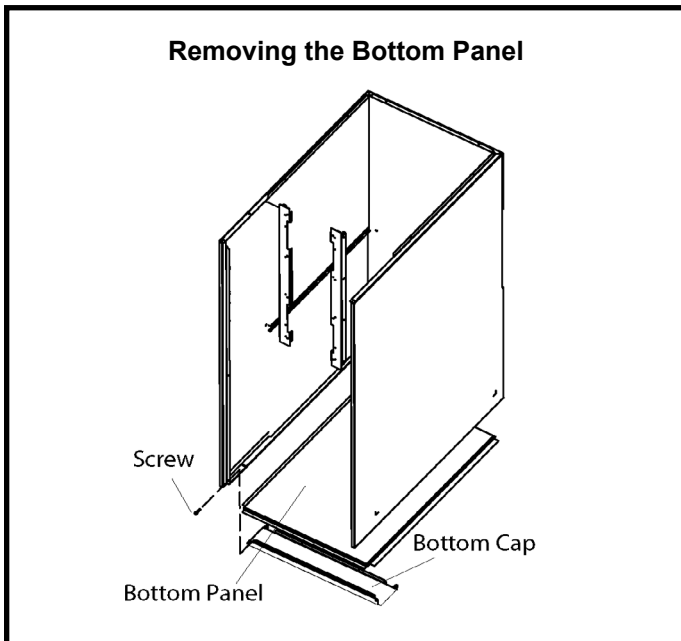

Figure 16

Removing the Bottom Panel

Remove the two screws that secure the bottom cap to the furnace. Pivot the bottom cap down to release the bottom panel. Once the bottom panel has been removed, reinstall the bottom cap. See Figure 16.

Horizontal Applications



Do not install the furnace on its front or its back. See Figure 17.

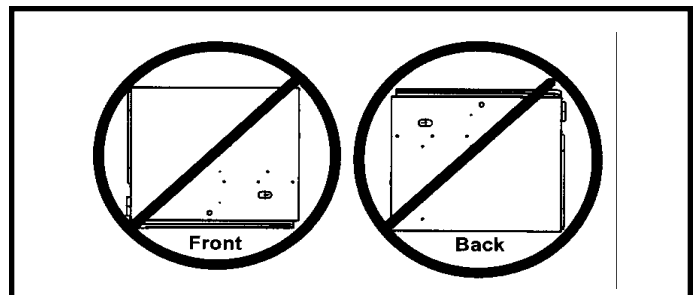

Figure 17

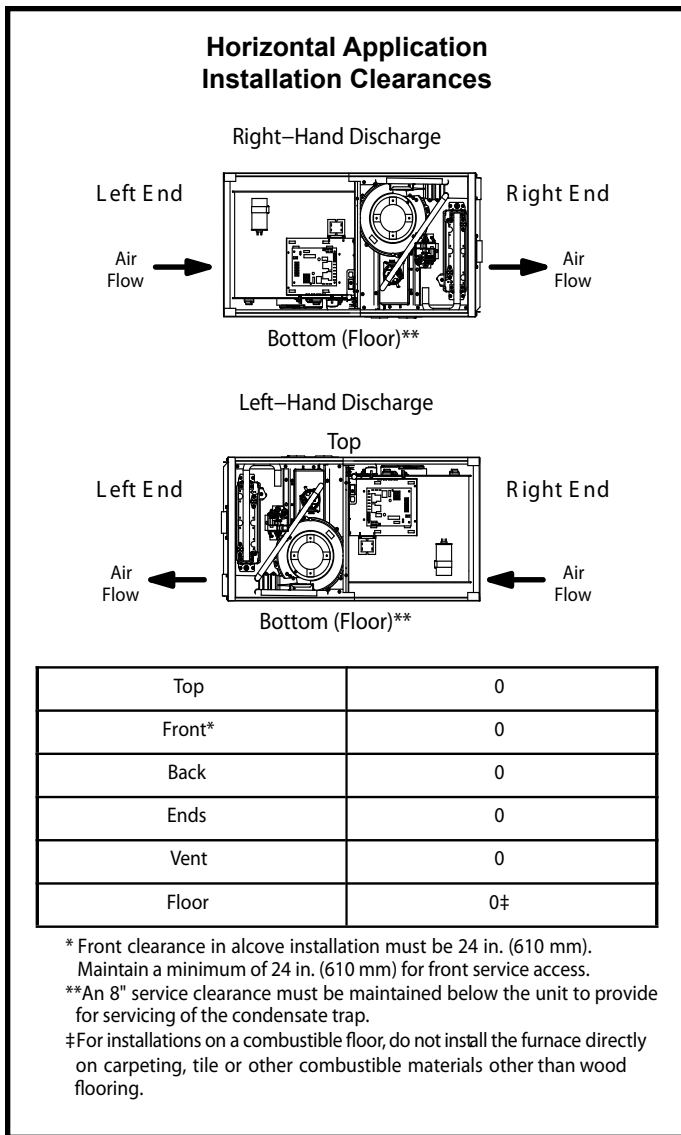

Figure 18

This furnace can be installed in horizontal applications with either right or left hand air discharge.

Refer to Figure 18 for clearances in horizontal applications.

Suspended Installation of Horizontal Unit

This furnace may be installed in either an attic or a crawl space. Either suspend the furnace from roof rafters or floor joists, as shown in Figure 19, or install the furnace on a platform, as shown in Figure 20. A horizontal suspension kit (51W10) may be ordered from your distributor or use equivalent.

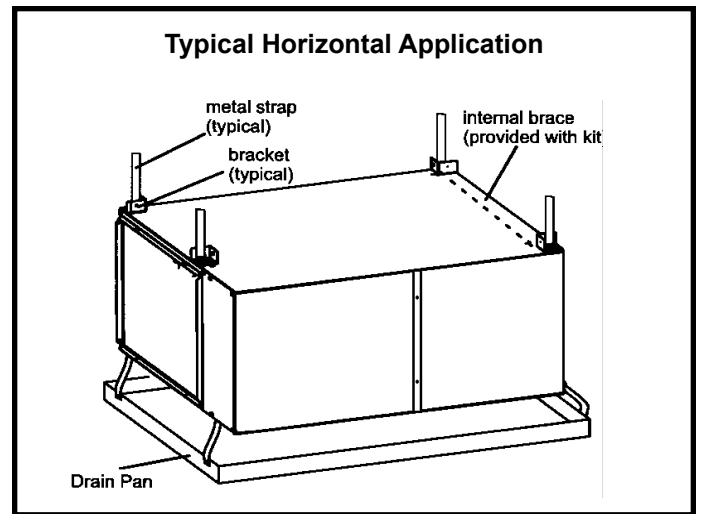

Figure 19

NOTE: Heavy-gauge sheet metal straps may be used to suspend the unit from roof rafters or ceiling joists. When straps are used to suspend the unit in this way, support must be provided for both the ends. The straps must not interfere with the plenum or exhaust piping installation.

Cooling coils and supply and return air plenums must be supported separately.

NOTE: When the furnace is installed on a platform or with the horizontal suspension kit in a crawl space, it must be elevated enough to avoid water damage, accommodate drain trap and to allow the evaporator coil to drain.

Platform Installation of Horizontal Unit

1. Select location for unit keeping in mind service and other necessary clearances. See Figure 18.
2. Construct a raised wooden frame and cover frame with a plywood sheet. If unit is installed above finished space, fabricate an auxiliary drain pan to be installed under unit. Set unit in drain pan as shown in Figure 20. Leave 8 inches for service clearance below unit for condensate trap.
3. Provide a service platform in front of unit. When installing the unit in a crawl space, a proper support platform may be created using cement blocks.
4. Route auxiliary drain line so that water draining from this outlet will be easily noticed by the homeowner.
5. If necessary, run the condensate line into a condensate pump to meet drain line slope requirements. The pump must be rated for use with condensing furnaces. Protect the condensate discharge line from the pump to the outside to avoid freezing.
6. Continue with exhaust, condensate and intake piping installation according to instructions.

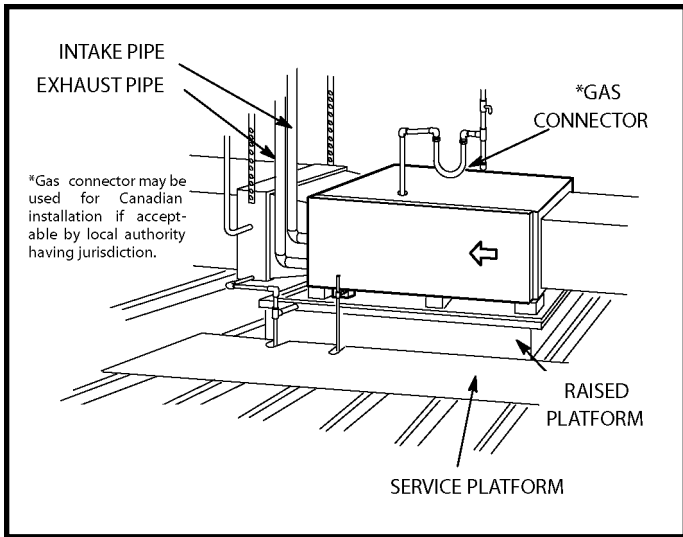

Figure 20

Return Air - Horizontal Applications

Return air may be brought in only through the end of a furnace installed in the horizontal position. The furnace is equipped with a removable bottom panel to facilitate installation. See Figure 16.

Filters

This unit is not equipped with a filter or rack. A field provided filter is required for the unit to operate properly. Table 1 list recommended filter sizes.

A filter must be in place whenever the is operating.

Furnace Cabinet Width	Filter Size	
	Side Return	Bottom Return
17-1/2"	16 X 25 X 1 (1)	16 X 25 X 1 (1)
21"	16 X 25 X 1 (1)	20 X 25 X 1 (1)
24-1/2"	16 X 25 X 1 (2)	24 X 25 X 1 (1)

Table 1

Duct System

Use industry approved standards to size and install the supply and return air duct system. This will result in a quiet and low-static system that has uniform air distribution.

NOTE: *This furnace is not certified for operation in heating mode (indoor blower operating at selected heating speed) with an external static pressure which exceeds 0.5 inches w.c. Operation at these conditions may result in improper limit operation.*

Supply Air Plenum

If the furnace is installed without a cooling coil, a removable access panel should be installed in the supply air duct. The access panel should be large enough to permit inspection (by reflected light) of the heat exchanger for leaks after the furnace is installed. The furnace access panel must always be in place when the furnace is operating and it must not allow leaks into the supply air duct system.

Return Air Plenum

NOTE: *Return air must not be drawn from a room where this furnace, or any other gas fueled appliance (i.e., water heater), or carbon monoxide producing device (i.e., wood fireplace) is installed.*

When return air is drawn from a room, a negative pressure is created in the room. If a gas appliance is operating in a room with negative pressure, the flue products can be pulled back down the vent pipe and into the room. This reverse flow of the flue gas may result in incomplete combustion and the formation of carbon monoxide gas. This raw gas or toxic fumes might then be distributed throughout the house by the furnace duct system.

Return air can be brought in through the bottom or either side of the furnace. If a furnace with bottom return air is installed on a platform, make an airtight seal between the bottom of the furnace and the platform to ensure that the unit operates properly and safely. Use fiberglass sealing strips, caulking, or equivalent sealing method between the plenum and the furnace cabinet to ensure a tight seal. If a filter is installed, size the return air duct to fit the filter frame.

Pipe & Fittings Specifications

All pipe, fittings, primer and solvent cement must conform with American National Standard Institute and the American Society for Testing and Materials (ANSI/ASTM) standards. The solvent shall be free flowing and contain no lumps, undissolved particles or any foreign matter that adversely affects the joint strength or chemical resistance of the cement. The cement shall show no gelation, stratification, or separation that cannot be removed by stirring. Refer to Table 2 for approved piping and fitting materials.

⚠ CAUTION

Solvent cements for plastic pipe are flammable liquids and should be kept away from all sources of ignition. Do not use excessive amounts of solvent cement when making joints. Good ventilation should be maintained to reduce fire hazard and to minimize breathing of solvent vapors. Avoid contact of cement with skin and eyes.

⚠ IMPORTANT

A95UH1E & 95G1UHE exhaust and intake connections are made of PVC. Use PVC primer and solvent cement when using PVC vent pipe. When using ABS vent pipe, use transitional solvent cement to make connections to the PVC fitting in the unit.

PIPING AND FITTINGS SPECIFICATIONS

Schedule 40 PVC (Pipe)	D1785
Schedule 40 PVC (Cellular Core Pipe)	F891
Schedule 40 PVC (Fittings)	D2466
Schedule 40 CPVC (Pipe)	F441
Schedule 40 CPVC (Fittings)	F438
SDR-21 PVC or SDR-26 PVC (Pipe)	D2241
SDR-21 CPVC or SDR-26 CPVC (Pipe)	F442
Schedule 40 ABS Cellular Core DWV (Pipe)	F628
Schedule 40 ABS (Pipe)	D1527
Schedule 40 ABS (Fittings)	D2468
ABS-DWV (Drain Waste & Vent) (Pipe & Fittings)	D2661
PVC-DWV (Drain Waste & Vent) Pipe & Fittings)	D2665
PRIMER & SOLVENT CEMENT	ASTM SPECIFICATION
PVC & CPVC Primer	F656
PVC Solvent Cement	D2564
CPVC Solvent Cement	F493
ABS Solvent Cement	D2235
PVC/CPVC/ABS All Purpose Cement For Fittings & Pipe of the same material	D2564, D2235, F493
ABS to PVC or CPVC Transition Solvent Cement	D3138
CANADA PIPE & FITTING & SOLVENT CEMENT	MARKING
PVC & CPVC Pipe and Fittings	ULCS636
PVC & CPVC Solvent Cement	
ABS to PVC or CPVC Transition Cement	
POLYPROPYLENE VENTING SYSTEM	ULC-S636
PolyPro® by Duravent	
InnoFlue® by Centrotherm	

Table 2

Use PVC primer and solvent cement or ABS solvent cement meeting ASTM specifications, refer to Table 2. As an alternate, use all purpose cement, to bond ABS, PVC, or CPVC pipe when using fittings and pipe made of the same materials. Use transition solvent cement when bonding ABS to either PVC or CPVC.

Low temperature solvent cement is recommended during cooler weather. Metal or plastic strapping may be used for vent pipe hangers. Uniformly apply a liberal coat of PVC primer for PVC or use a clean dry cloth for ABS to clean inside socket surface of fitting and male end of pipe to depth of fitting socket.

Canadian Applications Only

Pipe, fittings, primer and solvent cement used to vent (exhaust) this appliance must be certified to ULC S636 and supplied by a single manufacturer as part of an approved vent (exhaust) system. When bonding the vent system to the furnace, use ULC S636 approved One-Step Transition Cement to bond the pipe to the flue collar, or to bond the 90° elbow or reducing 90° elbow to the flue collar. In addition, the first three feet of vent pipe from the furnace flue collar must be accessible for inspection.

OUTDOOR TERMINATION KITS USAGE

A96UH2E 95G1UHE	VENT PIPE DIA. (in.)	STANDARD			CONCENTRIC		
		Outdoor Exhaust Accelerator (Dia. X Length)	Outdoor Exhaust Accelerator (Dia. X Length)	Flush Mount Kit	1-1/2" Concentric Kit	2" Concentric Kit	3" Concentric Kit
		1-1/2" x12"	2" x12"	51W11**	71M80 OR +44W92++	69M29 OR +44W92++	60L46 OR 44W93+
030 045	2	YES		YES	YES		
	2-1/2"	YES		YES	YES		
	3	YES		YES	YES		
70	2	YES		YES	YES		
	2-1/2"	YES		YES	YES		
	3	YES		YES	YES		
90	2		YES	YES		YES	YES
	2-1/2"		YES	YES		YES	YES
	3		YES	YES		YES	YES
110	2		YES	YES		YES	YES
	2-1/2"		YES	YES		YES	YES
	3		YES	YES		YES	YES
135	3		YES	YES			YES

* Requires field provided end installed 1-1/2" exhaust accelerator.

** kit 51W11 is provided with e 1-1/2" ecellerator which must be used for all 45,000 and 70,000 furnace installations.

+Termination kits 44W92, 44W93, 30g28 & 81J20 approved for use in Canadian installations to meet CSAB149.

++The 44W92 Concentric kit is provided with a 1-1/2" accelerator which must be installed on the exhaust outlet when this kit is used with the 45,000 and 70,000 furnaces.

Table 3

Joint Cementing Procedure

All cementing of joints should be done according to the specifications outlined in ASTM D 2855.

NOTE: A sheet metal screw may be used to secure the *intake* pipe to the connector, if desired. Use a drill or self tapping screw to make a pilot hole.



DANGER OF EXPLOSION!

Fumes from PVC glue may ignite during system check. Allow fumes to dissipate for at least 5 minutes before placing unit into operation.

1. Measure and cut vent pipe to desired length.
2. Debur and chamfer end of pipe, removing any ridges or rough edges. If end is not chamfered, edge of pipe may remove cement from fitting socket and result in a leaking joint.
3. Clean and dry surfaces to be joined.
4. Test fit joint and mark depth of fitting on outside of pipe.
5. Uniformly apply a liberal coat of PVC primer for PVC or use a clean dry cloth for ABS to clean inside socket surface of fitting and male end of pipe to depth of fitting socket.

NOTE: Time is critical at this stage. Do not allow primer to dry before applying cement.

6. Promptly apply solvent cement to end of pipe and inside socket surface of fitting. Cement should be applied lightly but uniformly to inside of socket. Take care to keep excess cement out of socket. Apply second coat to end of pipe.
7. Immediately after applying last coat of cement to pipe, and while both inside socket surface and end of pipe are wet with cement, forcefully insert end of pipe into socket until it bottoms out. Turn PVC pipe 1/4 turn during assembly (but not after pipe is fully inserted) to distribute cement evenly. Do not turn ABS or cellular core pipe.

NOTE: Assembly should be completed within 20 seconds after last application of cement. Hammer blows should not be used when inserting pipe.

8. After assembly, wipe excess cement from pipe at end of fitting socket. A properly made joint will show a bead around its entire perimeter. Any gaps may indicate an improper defective assembly due to insufficient solvent.
9. Handle joints carefully until completely set.

Venting Practices

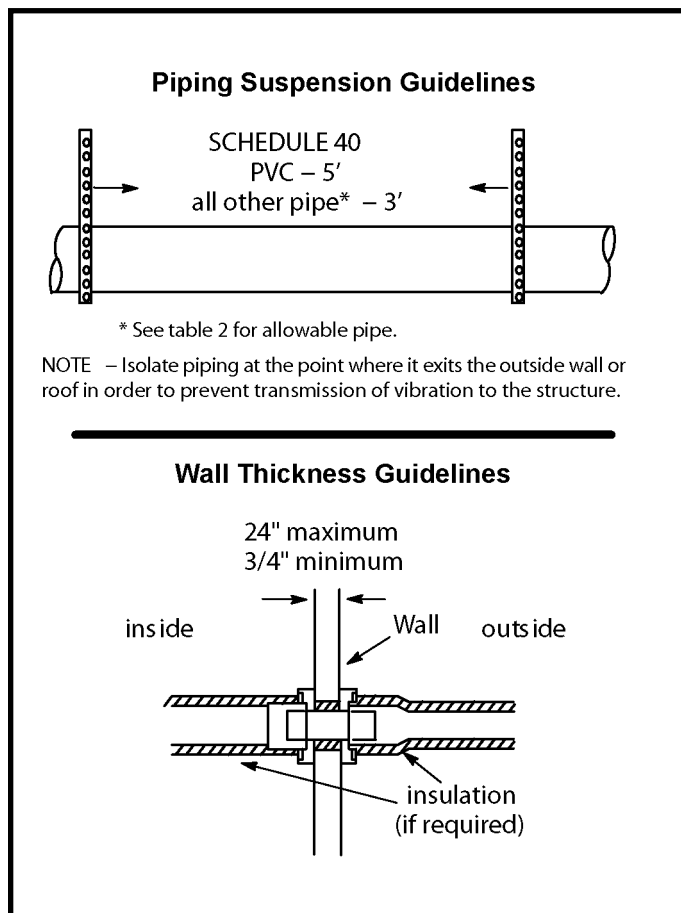

Figure 21

Removal of the Furnace from Common Vent

In the event that an existing furnace is removed from a venting system commonly run with separate gas appliances, the venting system is likely to be too large to properly vent the remaining attached appliances.

Conduct the following test while each appliance is operating and the other appliances (which are not operating) remain connected to the common venting system. If the venting system has been installed improperly, you **must** correct the system as indicated in the general venting requirements section.

WARNING

CARBON MONOXIDE POISONING HAZARD

Failure to follow the steps outlined below for each appliance connected to the venting system being placed into operation could result in carbon monoxide poisoning or death.

The following steps shall be followed for each appliance connected to the venting system being placed into operation, while all other appliances connected to the venting system are not in operation.

1. Seal any unused openings in the common venting system.
2. Inspect the venting system for proper size and horizontal pitch. Determine that there is no blockage, restriction, leakage, corrosion, or other deficiencies which could cause an unsafe condition.
3. Close all building doors and windows and all doors between the space in which the appliances remaining connected to the common venting system are located and other spaces of the building. Turn ON clothes dryers and any appliances not connected to the common venting system. Turn ON any exhaust fans, such as range hoods and bathroom exhausts, so they will operate at maximum speed. Do not operate a summer exhaust fan. Close fireplace dampers.
4. Follow the lighting instructions. Turn ON the appliance that is being inspected. Adjust the thermostat so that the appliance operates continuously.

5. After the main burner has operated for 5 minutes, test for leaks of flue gases at the draft hood relief opening. Use the flame of a match or candle.
6. After determining that each appliance connected to the common venting system is venting properly, (step 3) return all doors, windows, exhaust fans, fireplace dampers, and any other gas burning appliances to their previous mode of operation.
7. If a venting problem is found during any of the preceding tests, the common venting system must be modified to correct the problems.

Resize the common venting system to the minimum vent pipe size determined by using the appropriate tables in Appendix G. (These are in the current standards of the National Fuel Gas Code ANSI Z223.1.

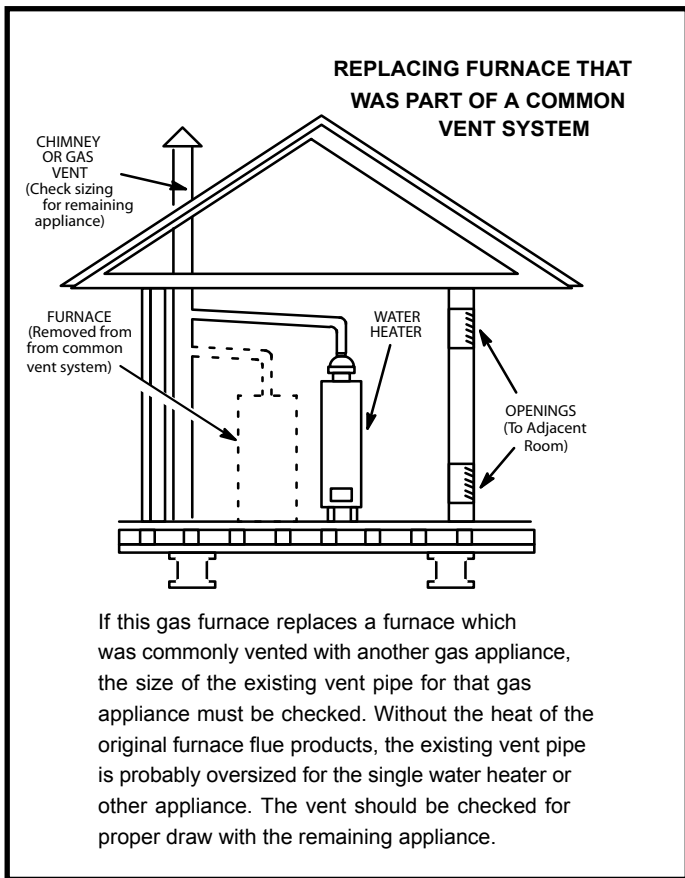

Figure 22

Exhaust Piping (Figures 25 and 26)

1. In areas where piping penetrates joist or interior walls, hole must be large enough to allow clearance on all sides of pipe through center of hole using a hanger.
2. When furnace is installed in a residence where unit is shut down for an extended period of time, such as a vacation home, make provisions for draining condensate collection from trap and lines.
3. Route piping to outside of structure. Continue with installation following instructions given in piping termination section.



Do not discharge exhaust into an existing stack or stack that also serves another gas appliance. If vertical discharge through an existing unused stack is required, insert PVC pipe inside the stack until the end is even with the top or outlet end of the metal stack.



The exhaust vent pipe operates under positive pressure and must be completely sealed to prevent leakage of combustion products into the living space.

Vent Piping Guidelines

This gas furnace can be installed as either a Non-Direct Vent or a Direct Vent gas central furnace.

NOTE: *In non-Direct Vent installations, combustion air is taken from indoors and flue gases are discharged outdoors. In Direct Vent installations, combustion air is taken from outdoors and flue gases are discharged outdoors.*

*Intake and exhaust pipe sizing - Size pipe according to Tables 4, 5 and 6. Table 4 lists the **minimum** vent pipe lengths permitted. Table 5 and 6 list the **maximum** pipe lengths permitted.*

Regardless of the diameter of pipe used, the standard roof and wall terminations described in section *Exhaust Piping Terminations* should be used. Exhaust vent termination pipe is sized to optimize the velocity of the exhaust gas as it exits the termination. Refer to Table 8.

In some applications which permit the use of several different sizes of vent pipe, a combination vent pipe may be used. Contact Allied Air Technical Service for assistance in sizing vent pipe in these applications.

NOTE: It is acceptable to use any pipe size which fits within the guidelines allowed in Table 5.

NOTE: The exhaust collar on all models is sized to accommodate 2" Schedule 40 vent pipe. In horizontal applications, transition to exhaust pipe larger than 2" must be made in vertical runs of the pipe. A 2" elbow must be added before the pipe is transitioned to any size larger than 2". This elbow must be added to the elbow count used to determine acceptable vent lengths. Contact the Application Department for more information concerning sizing of vent systems which include multiple pipe sizes.

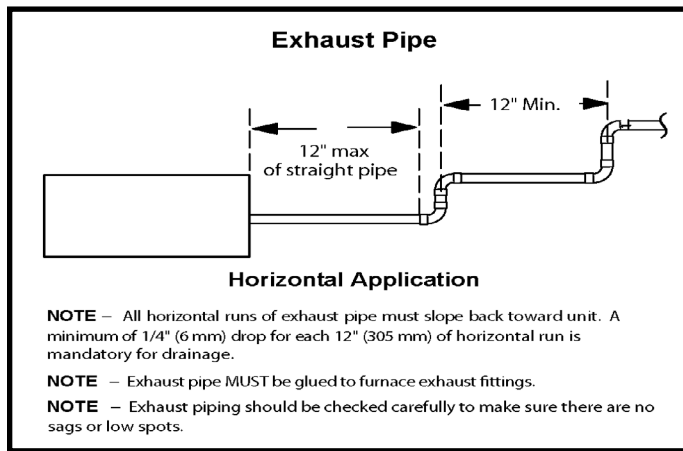

Figure 23

⚠ IMPORTANT

Do not use screens or perforated metal in exhaust or intake terminations. Doing so will cause freeze-ups and may block the terminations.

MINIMUM VENT PIPE LENGTHS	
A95UH1E/95G1UHE MODELS	MIN. VENT LENGTH*
030,045,070,090,110	15 ft or 5 ft plus 2 elbows or 10 ft plus 1 elbow
135 **	

*Any approved termination may be added to the minimum length listed.
 ** This gas furnace must have 3" to 2" reducing elbow (supplied or field replacement Canadian kit) installed directly

Table 4

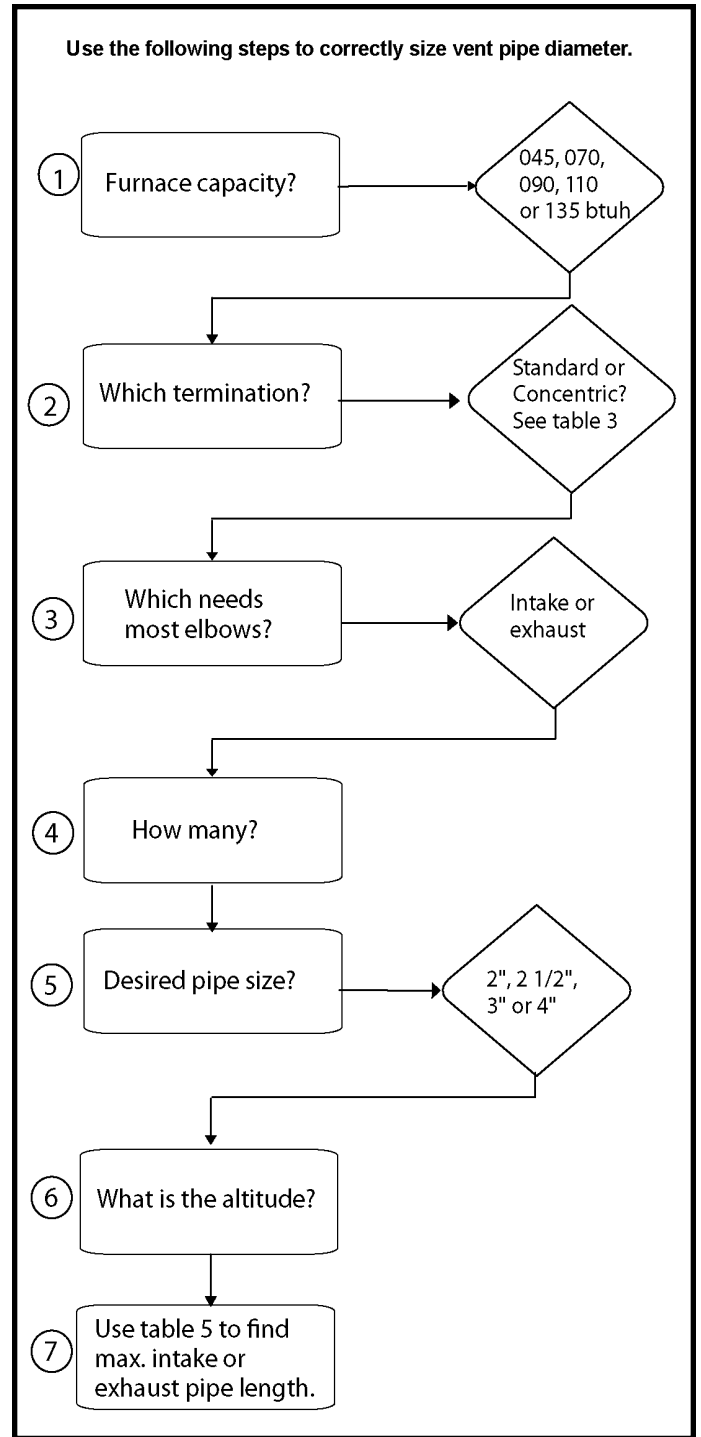

Figure 24

A95UH1E & 95G1UHE Maximum Allowable Intake or Exhaust Vent Length in Feet

Standard Termination at Elevation 0 - 4,500 ft															
Number Of 90° Elbows Used	2nd Pipe					2-1/2" Pipe					3" Pipe				
	Modal					Modal					Modal				
	030 045	70	90	110	135	030 045	70	90	110	135	030 045	70	90	110	115
1	76	61	39	19	n/a	110	95	63	38	n/a	132	132	113	113	109
2	71	56	34	14		105	90	58	33		127	127	108	108	104
3	66	51	29	9		100	85	53	28		122	122	103	103	99
4	61	46	24	9		95	80	48	23		117	117	98	98	94
5	56	41	19	9		90	75	43	18		112	112	93	93	89
6	51	36	14	9		85	70	38	13		107	107	88	88	84
7	46	31	9	9		80	65	33	8		102	102	83	83	79
8	41	26	9	9		75	60	28	8		97	97	78	78	74
9	36	21	9	9		70	55	23	n/a		92	92	73	73	69
10	31	16	9	9		65	50	18	n/a		87	87	68	68	64

Standard Termination at Elevation 4,500 - 10,000 ft															
Number Of 90° Elbows Used	2nd Pipe					2-1/2" Pipe					3" Pipe				
	Modal					Modal					Modal				
	030 045	70	90	110	135	030 045	70	Om	110	135	030 045	70	90	110	135
1	76	61	39	n/a	n/a	110	95	63	38	n/a	132	132	113	113	109
2	71	56	34			105	90	58	33		127	127	108	108	104
3	66	51	29			100	85	53	28		122	122	103	103	99
4	61	46	24			95	80	48	23		117	117	98	98	94
5	56	41	19			90	75	43	18		112	112	93	93	89
6	51	36	14			85	70	38	13		107	107	88	88	84
7	46	31	9			80	65	33	8		102	102	83	83	79
8	41	26	9			75	60	28	8		97	97	78	78	74
9	36	21	9			70	55	23	n/a		92	92	73	73	69
10	31	16	9			65	50	18	n/a		87	87	68	68	64

Maximum Allowable Intake or Exhaust Vent Length in Feet

Concentric Termination at Elevation 0 - 4,500 ft															
Number Of 90° Elbows Used	2" Pipe					2-1/2" Pipe					3" Pipe				
	Modal					Modal					Modal				
	030 045	70	90	110	135	030 045	70	90	110	135	030 045	70	90	110	135
1	68	53	37	17	n/a	100	85	59	34	n/a	116	116	109	109	100
2	63	48	32	12		95	80	54	29		111	111	104	104	95
3	58	43	27	7		90	75	49	24		106	106	99	99	90
4	53	38	22	7		85	70	44	19		101	101	94	94	85
5	48	33	17	7		80	65	39	14		96	96	89	89	80
6	43	28	12	7		75	60	34	14		91	91	84	84	75
7	38	23	7	7		70	55	29	n/a		86	86	79	79	70
8	33	18	7	7		65	50	24	n/a		81	81	74	74	65
9	28	13	7	7		60	45	19	n/a		76	76	69	69	60
10	23	8	7	7		55	40	14	n/a		71	71	64	64	55

Concentric Termination Elevation 4500 - 10,000 ft															
Number Of 90° Elbows Used	2" Pipe					2-1/2" Pipe					3" Pipe				
	Modal					Modal					Modal				
	030 045	70	90	110	135	030 045	70	90	110	135	030 045	70	0	110	135
1	68	53	37	n/a	n/a	100	85	59	34	n/a	116	116	109	109	100
2	63	48	32			95	80	54	29		111	111	104	104	95
3	58	43	27			90	75	49	24		106	106	99	99	90
4	53	38	22			85	70	44	19		101	101	94	94	85
5	48	33	17			80	65	39	14		96	96	89	89	80
6	43	28	12			75	60	34	14		91	91	84	84	75
7	38	23	7			70	55	29	n/a		86	86	79	79	70
8	33	18	7			65	50	24	n/a		81	81	74	74	65
9	28	13	7			60	45	19	n/a		76	76	69	69	60
10	23	8	7			55	40	14	n/a		71	71	64	64	55

*Size intake and exhaust pipe length separately. Values in table are for intake OR Exhaust, not combined total. Both Intake and Exhaust must be same pipe size.

Table 5

Maximum Allowable Exhaust Vent Lengths with Furnace Installed in a Closet or Basement Using Ventilated Attic or Crawl Space for Intake Air in Feet

Standard Termination at Elevation 0 - 4,500 ft																
Number Of 90° Elbows Used	2" Pipe					2-1/2" Pipe					3" Pipe					
	Model					Model					Model					
	030 045	70	90	110	135	030 045	70	90	110	135	030 045	70	90	110	135	
1	66	51	29	9	n/a	95	95	73	38	n/a	113	112	93	93	89	
2	61	46	24	4		90	90	68	33		108	107	88	88	88	84
3	56	41	19	n/a		85	85	63	28		103	102	83	83	83	79
4	51	36	14			80	80	58	23		98	97	78	78	78	74
5	46	31	9			85	75	53	18		93	92	73	73	73	69
6	41	26	4			70	70	48	13		88	87	68	68	68	64
7	36	21	n/a			65	65	43	8		83	82	63	63	63	59
8	31	16				60	60	38	3		78	77	58	58	58	54
9	26	11	n/a			55	55	33	n/a		73	72	53	53	53	49
10	21	6				50	50	28			68	67	48	48	44	
Standard Termination Elevation 4,500 - 10,000 ft																
.....																
Number Of 90° Elbows Used	2" Pipe					2-1/2" Pipe					3" Pipe					
	Model					Model					Model					
	030 045	70	90	110	135	030 045	70	90	110	135	030 045	70	90	110	135	
1	66	51	29	n/a	n/a	95	95	73	38	n/a	113	112	93	93	89	
2	61	46	24			90	90	68	33		108	107	88	88	88	84
3	56	41	19			85	85	63	28		103	102	83	83	83	79
4	51	36	14			80	80	58	23		98	97	78	78	78	74
5	46	31	9			85	85	53	18		93	92	73	73	73	69
6	41	26	4			70	70	48	13		88	87	68	68	68	64
7	36	21	n/a			65	65	43	8		83	82	63	63	63	59
8	31	16				60	60	38	3		78	77	58	58	58	54
9	26	11	n/a			55	55	33	n/a		73	72	53	53	53	49
10	21	6				50	50	28			68	67	48	48	44	

* Size intake and exhaust pipe length separately. Values in table are for intake OR Exhaust, not combined total. Both Intake and Exhaust must be same pipe size.
 * Additional vent pipe and elbows used to terminate the vent pipe outside the structure must be included in the total vent length calculation.

Table 6

TYPICAL EXHAUST PIPE CONNECTIONS IN UPFLOW DIRECT OR NON-DIRECT VENT APPLICATIONS

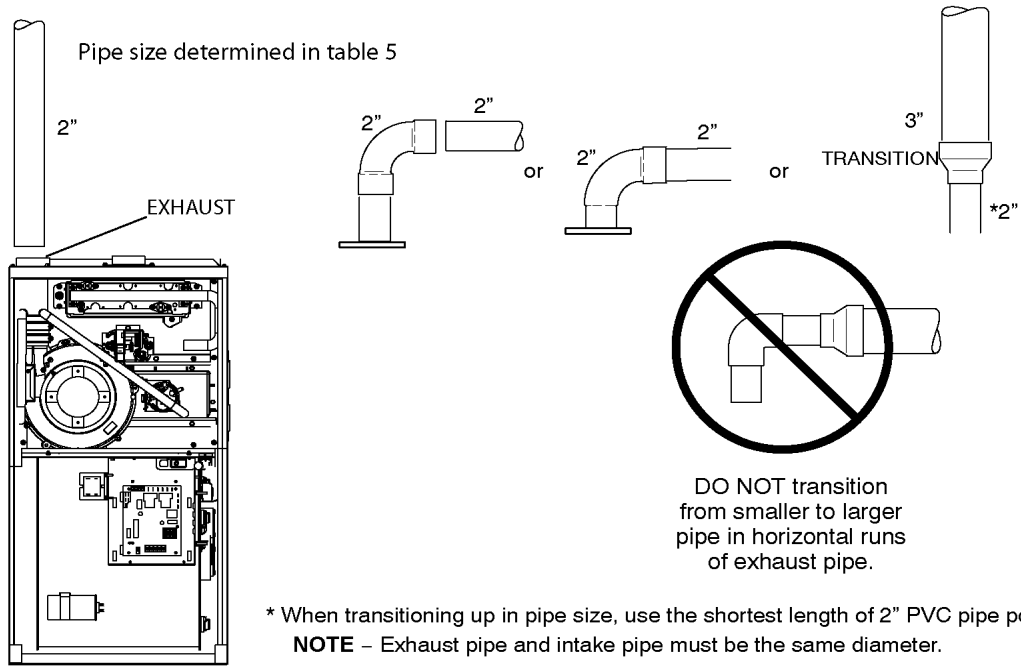

Figure 25

TYPICAL EXHAUST PIPE CONNECTIONS IN HORIZONTAL DIRECT OR NON-DIRECT VENT APPLICATIONS (RIGHT HAND DISCHARGE SHOWN)

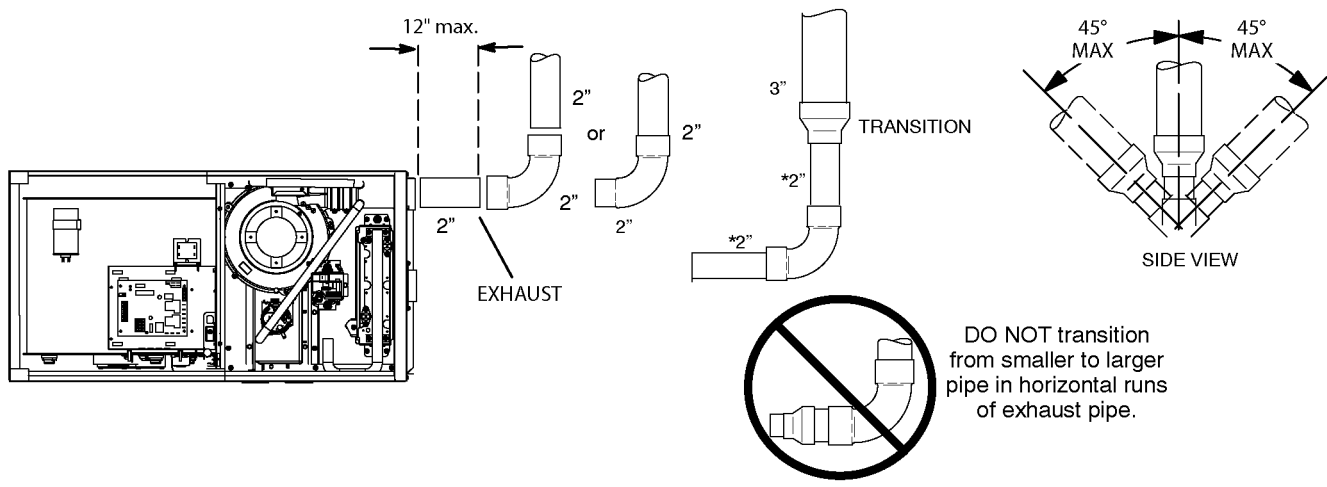

Figure 26

TYPICAL AIR INTAKE PIPE CONNECTIONS IN UPFLOW DIRECT VENT APPLICATIONS

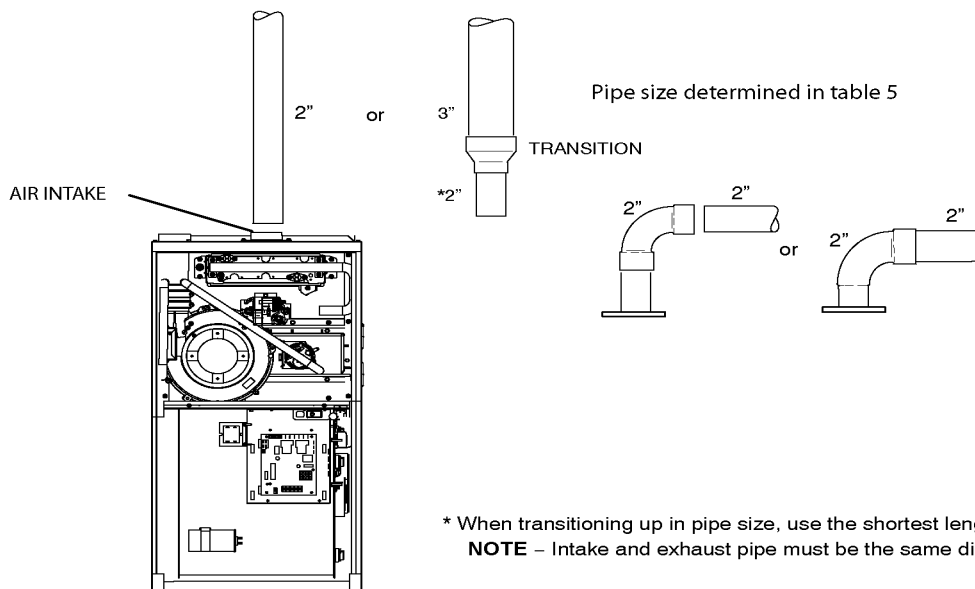

Figure 27

TYPICAL AIR INTAKE PIPE CONNECTIONS IN HORIZONTAL DIRECT VENT APPLICATIONS (RIGHT HAND DISCHARGE SHOWN)

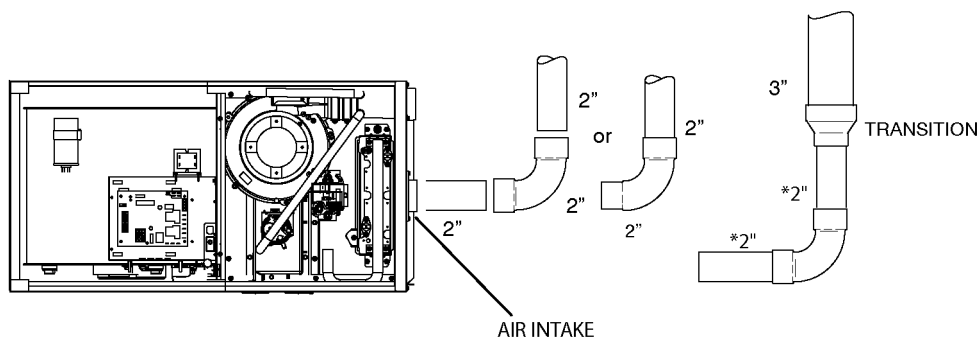

Figure 28

Intake Piping (Figures 27 through 28)

This gas furnace may be installed in either **direct vent** or **non-direct vent** applications. In non-direct vent applications, when intake air will be drawn into the furnace from the surrounding space, the indoor air quality must be considered and guidelines listed in Combustion, Dilution and Ventilation Air section must be followed.

Follow the next two steps when installing the unit in **Direct Vent applications**, where combustion air is taken from outdoors and flue gases are discharged outdoors. **The provided air intake screen must not be used in direct vent applications (outdoors).**

1. Use transition solvent cement or a sheet metal screw to secure the intake pipe to the inlet air connector.
2. Route piping to outside of structure. Continue with installation following instructions given in general guide lines for piping terminations and in intake and exhaust piping terminations for direct vent sections. Refer to Table 5 for pipe sizes.

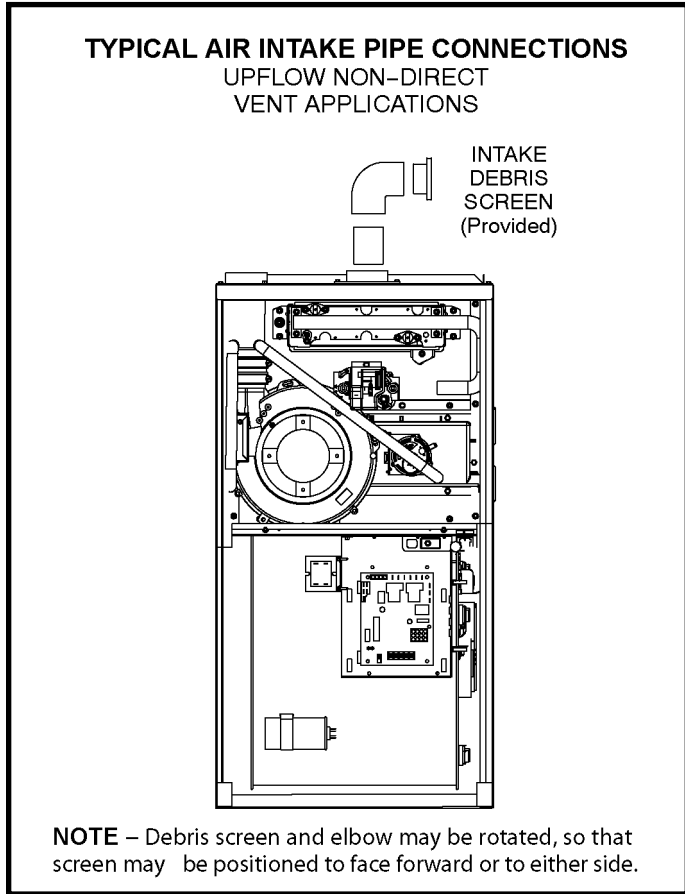

Figure 29

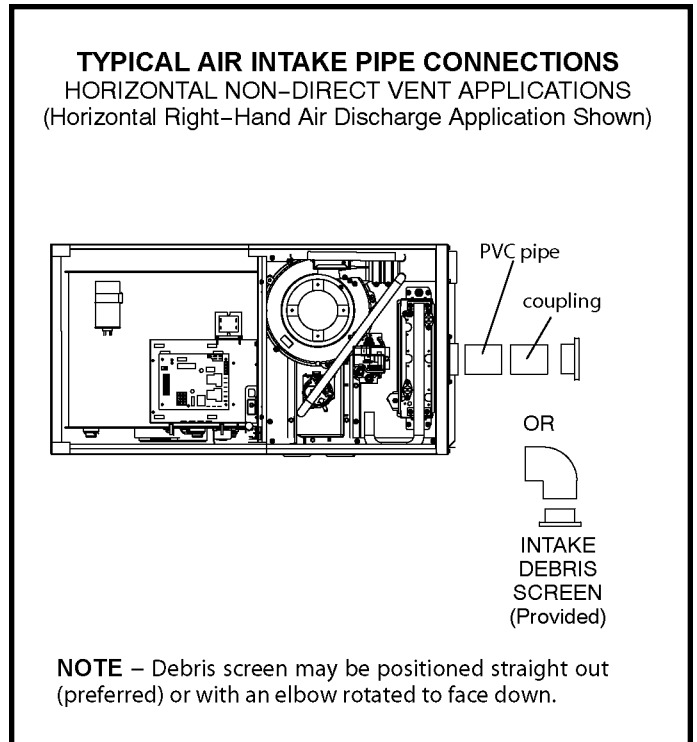

Figure 30

Follow the next two steps when installing the unit in **Non-Direct Vent applications** where combustion air is taken from indoors and flue gases are discharged outdoors.

1. Use field-provided materials and the factory-provided air intake screen to route the intake piping as shown in Figure 29 or 30. Maintain a minimum clearance of 3" (76 mm) around the air intake opening. The air intake opening (with the protective screen) should always be directed forward or to either side in the upflow position, and either straight out or downward in the horizontal position.

The air intake piping must not terminate too close to the flooring or a platform. Ensure that the intake air inlet will not be obstructed by loose insulation or other items that may clog the debris screen.

2. If intake air is drawn from a ventilated attic (Figure 31) or ventilated crawlspace (Figure 32) the exhaust vent length must not exceed those listed in Table 6. If 3" diameter pipe is used, reduce to 2" diameter pipe at the termination point to accommodate the debris screen.
3. Use a sheet metal screw to secure the intake pipe to the connector, if desired.

CAUTION

If this unit is being installed in an application with combustion air coming in from a space serviced by an exhaust fan, power exhaust fan, or other device which may create a negative pressure in the space, take care when sizing the inlet air opening. The inlet air opening must be sized to accommodate the maximum volume of exhaust air as well as the maximum volume of combustion air required for all gas appliances serviced by this space.

**EQUIPMENT IN CONFINED SPACE
(Inlet Air from Ventilated Attic and Outlet Air to Outside)**

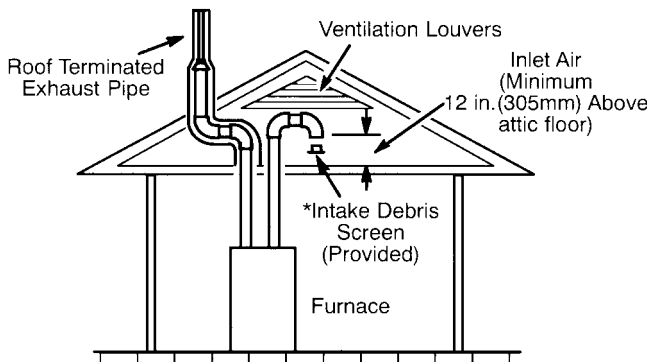

* See table 6 for maximum vent lengths

NOTE-The inlet and outlet air openings shall each have a free area of at least one square inch per 4,000 Btu (645 mm² per 1.17kW) per hour of the total input rating of all equipment in the enclosure.

Figure 31

**EQUIPMENT IN CONFINED SPACE
(Inlet Air from Ventilated Crawlspace and Outlet Air to Outside)**

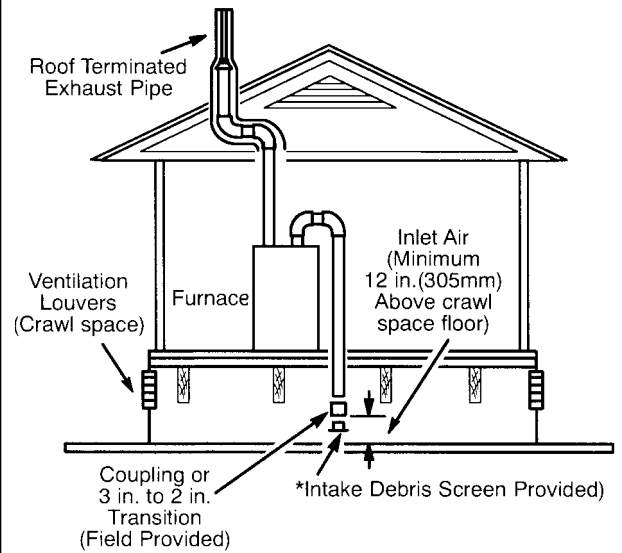

* See table 6 for maximum vent lengths

NOTE-The inlet and outlet air openings shall each have a free area of at least one square inch per 4,000 Btu (645 mm² per 1.17kW) per hour of the total input rating of all equipment in the enclosure.

Figure 32

General Guidelines for Vent Terminations

In Non-Direct Vent applications, combustion air is taken from indoors and the flue gases are discharged to the outdoors. This furnace is then classified as a non-direct vent, Category IV gas furnace.

In Direct Vent applications, combustion air is taken from outdoors and the flue gases are discharged to the outdoors. This furnace is then classified as a direct vent, Category IV gas furnace.

In both Non-Direct Vent and Direct Vent applications, the vent termination is limited by local building codes. In the absence of local codes, refer to the current National Fuel Gas Code ANSI Z223-1/NFPA 54 in U.S.A., and current CSA-B149 Natural Gas and Propane Installation Codes in Canada for details.

Position termination according to location given in Figure 33 or 34. In addition, position termination so it is free from any obstructions and 12" above the average snow accumulation.

At vent termination, care must be taken to maintain protective coatings over building materials (prolonged exposure to exhaust condensate can destroy protective

coatings). It is recommended that the exhaust outlet not be located within 6 feet (1.8 m) of a condensing unit because the condensate can damage the painted coating.

NOTE: See Table 7 for maximum allowed exhaust pipe length without insulation in unconditioned space during winter design temperatures below 32°F (0°C). If required exhaust pipe should be insulated with 1/2" (13 mm) Armaflex or equivalent. In extreme cold climate areas, 3/4" (19 mm) Armaflex or equivalent may be necessary. Insulation on outside runs of exhaust pipe must be painted or wrapped to protect insulation from deterioration. Exhaust pipe insulation may not be necessary in some specific applications.

NOTE: During extremely cold temperatures, below approximately 20° F (6.7° C), units with long runs of vent pipe through unconditioned space, even when insulated, may form ice in the exhaust termination that prevents the unit from operating properly. Longer run times of at least 5 minutes will alleviate most icing problems. Also, a heating cable may be installed on exhaust piping and termination to prevent freeze-ups. Heating cable installation kits are available. See unit specification sheets for part numbers.

! IMPORTANT

Do not use screens or perforated metal in exhaust terminations. Doing so will cause freeze-ups and may block the terminations.

! IMPORTANT

For Canadian Installations Only:

In accordance to CSA International B149 installation codes, the minimum allowed distance between the combustion air intake inlet and the exhaust outlet of other appliances shall not be less than 12 inches (305 mm).

Maximum Allowable Exhaust Vent Pipe Length (in ft.) Without Insulation
In Unconditioned Space For Winter Design Temperatures Single - Stage High Efficiency Furnace

Winter Design Temperatures ¹ °F (°C)	Vent Pipe Diameter	Unit Input Size									
		030/045		070		090		110		135	
		PVC	² PP	PVC	² PP	PVC	² PP	PVC	² PP	PVC	² PP
32 to 21 (0 to -6)	2 in.	18	16	31	28	50	48	30	30	N/A	N/A
	2-1/2 in.	13	N/A	24	N/A	42	N/A	56	N/A	N/A	N/A
	3 in.	9	9	18	18	35	35	47	47	52	52
20 to 1 (-7 to -17)	2 in.	9	8	18	16	32	29	30	30	N/A	N/A
	2-1/2 in.	5	N/A	13	N/A	24	N/A	34	N/A	N/A	N/A
	3 in.	N/A	N/A	8	8	19	19	26	26	30	30
0 to -20 (-18 to -29)	2 in.	5	3	12	10	22	19	30	27	N/A	N/A
	2-1/2 in.	N/A	N/A	7	N/A	15	N/A	22	N/A	N/A	N/A
	3 in.	N/A	N/A	N/A	N/A	10	10	16	16	18	18

¹ Refer to 99% Minimum Design Temperature table provided in the current edition of the ASHRAE Fundamentals Handbook.

² Poly-Propylene vent pipe (PP) by Duravent and Centrotherm

NOTE - Concentric terminations are the equivalent of 5' and should be considered when measuring pipe length.

NOTE- Maximum uninsulated vent lengths listed may include the termination (vent pipe exterior to the structure) and cannot exceed 5 linear feet or the maximum allowable intake or exhaust vent length listed in table 5 or 6.

NOTE - If insulation is required an unconditioned space, it must be located on the pipe closed to the furnace.

Table 7

VENT TERMINATION CLEARANCES FOR NON-DIRECT VENT INSTALLATIONS IN THE USA AND CANADA

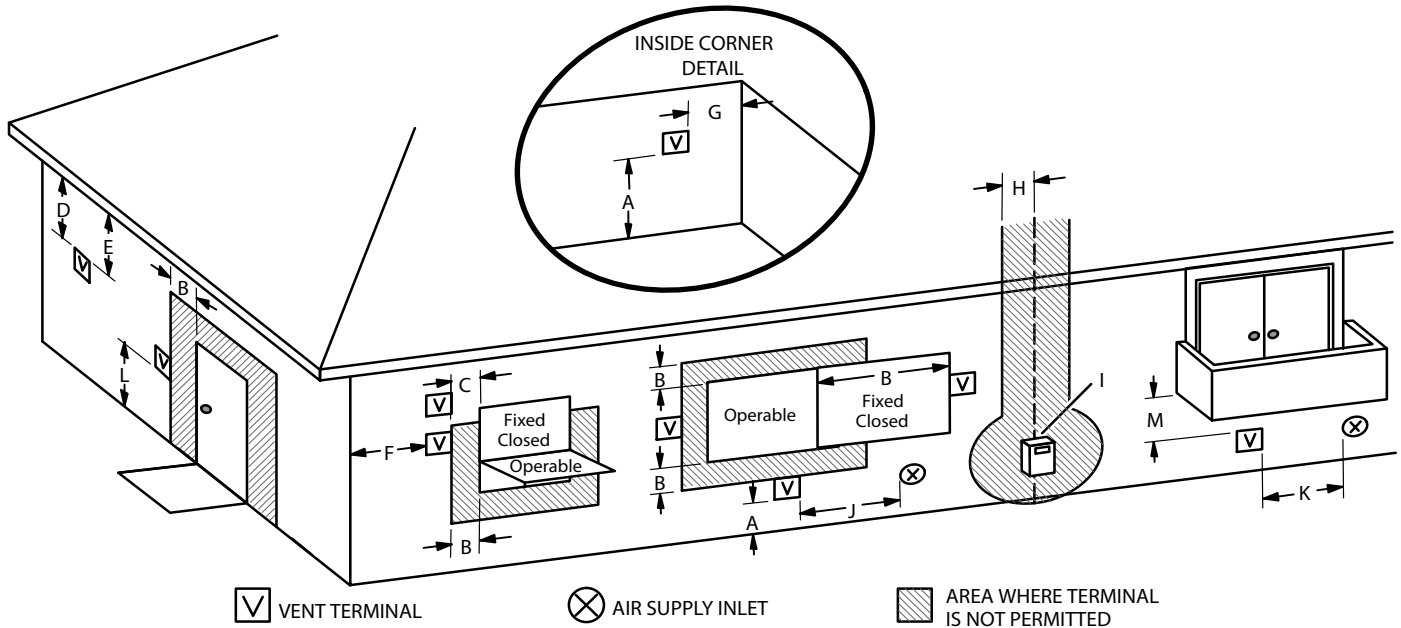

	US Installations ¹	Canadian Installations ²	
A =	Clearance above grade, veranda, porch, deck or balcony	12 inches (305mm) or 12 in. 305mm above average snow accumulation.	12 inches (305mm) or 12 in. 305mm above average snow accumulation.
B =	Clearance to window or door that may be opened	4 feet (1.2 m) below or to side of opening; 1 foot (30 cm) above opening	6 inches (152mm) for appliances <10,000 Btuh (3kw), 12 inches (305mm) for appliances > 10,000 Btuh (3kw) and <100,000 Btuh (30kw), 36 inches (.9m) for appliances > 100,000 Btuh (30kw)
C =	Clearance to permanently closed window	* 12"	* 12"
D =	Vertical clearance to ventilated soffit located above the terminal within a horizontal distance of 2 feet (mm) from the center line of the terminal	* Equal to or greater than soffit depth.	* Equal to or greater than soffit depth.
E =	Clearance to unventilated soffit	* Equal to or greater than soffit depth.	* Equal to or greater than soffit depth.
F =	Clearance to outside corner	* No minimum to outside corner	* No minimum to outside corner
G =	Clearance to inside corner	*	*
H =	Clearance to each side of center line extended above meter / regulator assembly	* 3 feet (.9m) within a height 15 feet (4.5m) above the meter / regulator assembly	3 feet (.9m) within a height 15 feet (4.5m) above the meter / regulator assembly
I =	Clearance to service regulator vent outlet	* 3 feet (.9m)	3 feet (.9m)
J =	Clearance to non-mechanical air supply inlet to building or the combustion air inlet to any other appliance	4 feet (1.2 m) below or to side of opening; 1 foot (30 cm) above opening	6 inches (152mm) for appliances <10,000 Btuh (3kw), 12 inches (305mm) for appliances > 10,000 Btuh (3kw) and <100,000 Btuh (30kw), 36 inches (.9m) for appliances > 100,000 Btuh (30kw)
K =	Clearance to mechanical air supply inlet	3 feet (.9m) above if within 10 feet (3m) horizontally	6 feet (1.8m)
L =	Clearance above paved sidewalk or paved driveway located on public property	7 feet (2.1m)†	7 feet (2.1m)†
M =	Clearance under veranda, porch, deck or balcony	*12 inches (305mm)‡	12 inches (305mm)‡

¹ In accordance with the current ANSI Z223.1/NFPA 54 Natural Fuel Gas Code

² In accordance with the current CSA B149.1, Natural Gas and Propane Installation Code

† A vent shall not terminate directly above a sidewalk or paved driveway that is located between two single family dwellings and serves both dwellings.

‡ Permitted only if veranda, porch, deck or balcony is fully open on a minimum of two sides beneath the floor. Lennox recommends avoiding this location if possible.

*For clearances not specified in ANSI Z223.1/NFPA 54 or CSA B149.1, clearance will be in accordance with local installation codes and the requirements of the gas supplier and these installation instructions."

Figure 33

VENT TERMINATION CLEARANCES FOR DIRECT VENT INSTALLATIONS IN THE USA AND CANADA

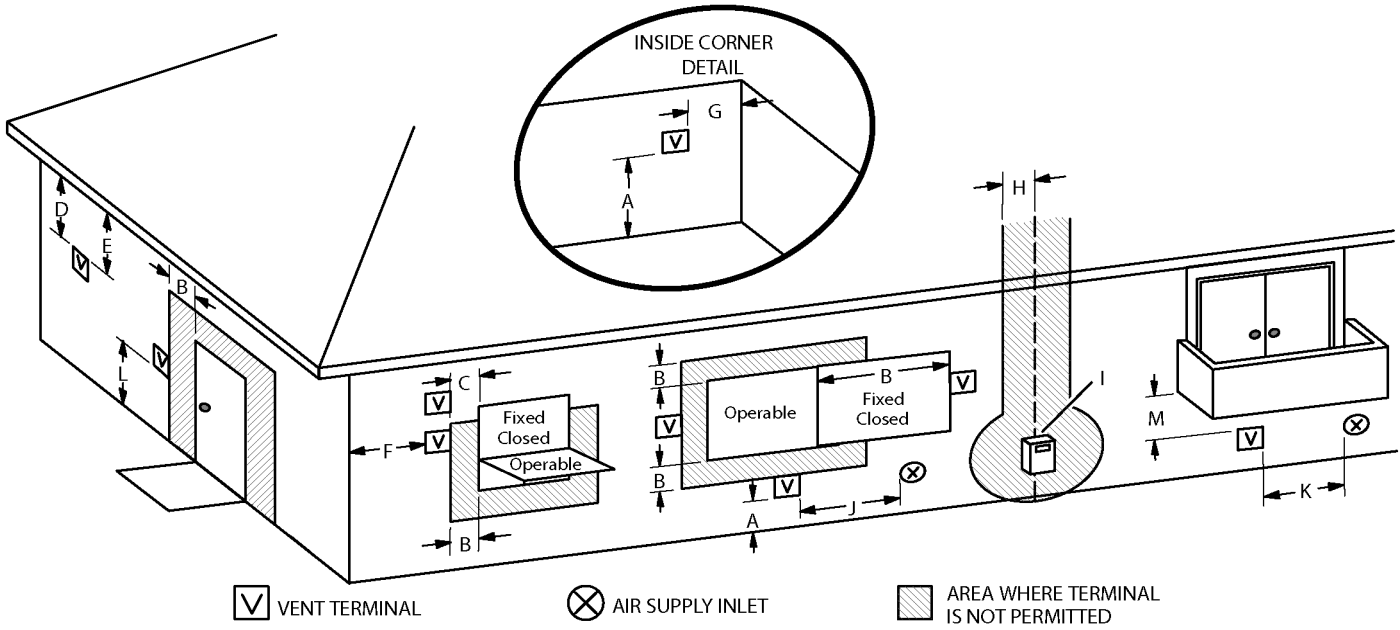

	US Installations ¹	Canadian Installations ²	
A =	Clearance above grade, veranda, porch, deck or balcony	12 inches (305mm) or 12 in. 305mm above average snow accumulation.	12 inches (305mm) or 12 in. 305mm above average snow accumulation.
B =	Clearance to window or door that may be opened	6 inches (152mm) for appliances <10,000 Btuh (3kw), 9 inches (mm) for appliances > 10,000 Btuh (3kw) and <50,000 Btuh (15 kw), 12 inches (305mm) for appliances > 50,000 Btuh (15kw)	6 inches (152mm) for appliances <10,000 Btuh (3kw), 12 inches (305mm) for appliances > 10,000 Btuh (3kw) and <100,000 Btuh (30kw), 36 inches (.9m) for appliances > 100,000 Btuh (30kw)
C =	Clearance to permanently closed window	* 12"	* 12"
D =	Vertical clearance to ventilated soffit located above the terminal within a horizontal distance of 2 feet (mm) from the center line of the terminal	* Equal to or greater than soffit depth	* Equal to or greater than soffit depth
E =	Clearance to unventilated soffit	* Equal to or greater than soffit depth	* Equal to or greater than soffit depth
F =	Clearance to outside corner	* No minimum to outside corner	* No minimum to outside corner
G =	Clearance to inside corner	*	*
H =	Clearance to each side of center line extended above meter / regulator assembly	3 feet (.9m) within a height 15 feet (4.5m) above the meter / regulator assembly	3 feet (.9m) within a height 15 feet (4.5m) above the meter / regulator assembly
I =	Clearance to service regulator vent outlet	* 3 feet (.9m)	3 feet (.9m)
J =	Clearance to non-mechanical air supply inlet to building or the combustion air inlet to any other appliance	6 inches (152mm) for appliances <10,000 Btuh (3kw), 9 inches (mm) for appliances > 10,000 Btuh (3kw) and <50,000 Btuh (15 kw), 12 inches (305mm) for appliances > 50,000 Btuh (15kw)	6 inches (152mm) for appliances <10,000 Btuh (3kw), 12 inches (305mm) for appliances > 10,000 Btuh (3kw) and <100,000 Btuh (30kw), 36 inches (.9m) for appliances > 100,000 Btuh (30kw)
K =	Clearance to mechanical air supply inlet	3 feet (.9m) above if within 10 feet (3m) horizontally	6 feet (1.8m)
L =	Clearance above paved sidewalk or paved driveway located on public property	* 7 feet (2.1m)	7 feet (2.1m)†
M =	Clearance under veranda, porch, deck or balcony	*12 inches (305mm)‡	12 inches (305mm)‡

¹ In accordance with the current ANSI Z223.1/NFPA 54 Natural Fuel Gas Code

² In accordance with the current CSA B149.1, Natural Gas and Propane Installation Code

† A vent shall not terminate directly above a sidewalk or paved driveway that is located between two single family dwellings and serves both dwellings.

‡ Permitted only if veranda, porch, deck or balcony is fully open on a minimum of two sides beneath the floor. Lennox recommends avoiding this location if possible.

*For clearances not specified in ANSI Z223.1/NFPA 54 or CSA B149.1, clearance will be in accordance with local installation codes and the requirements of the gas supplier and these installation instructions."

Figure 34

Details of Intake and Exhaust Piping Terminations for Direct Vent Installations

NOTE: In Direct Vent installations, combustion air is taken from outdoors and flue gases are discharged to outdoors.

NOTE: Flue gas may be slightly acidic and may adversely affect some building materials. If any vent termination is used and the flue gases may impinge on the building material, a corrosion-resistant shield (minimum 24 inches square) must be used to protect the wall surface. If the optional tee is used, the protective shield is required. The shield should be constructed using wood, plastic, sheet metal or other suitable material. All seams, joints, cracks, etc. in the affected area should be sealed using an appropriate sealant. See Figure 36.

Intake and exhaust pipes may be routed either horizontally through and outside wall or vertically through the roof. In attic or closet installations, vertical termination through the roof is preferred. Figures 35 through 43 show typical terminations.

1. Intake and exhaust terminations are not required to be in the same pressure zone. You may exit the intake on one side of the structure and the exhaust on another side (Figure 36). You may exit the exhaust out the roof and the intake out the side of the structure (Figure 37).
2. Intake and exhaust pipes should be placed as close together as possible at termination end (refer to illustrations). Maximum separation is 3" (76 mm) on roof terminations and 6" (152 mm) on sidewall terminations.
3. On roof terminations, the intake piping should terminate straight down using two 90° elbows (See Figure 35).
4. Exhaust piping must terminate straight out or up as shown. A reducer may be required on the exhaust piping at the point where it exits the structure to improve the velocity of exhaust away from the intake piping. See Table 8.

EXHAUST PIPE TERMINATION SIZE REDUCTION		
MODEL	Exhaust Pipe Size	Termination Pipe Size
030, 045 & 070	2" (51mm), 2 1/2" (64mm), 3" (76mm)	1-1/2" (38mm)
90		2" (51mm)
110		2" (51mm)
135		2" (51mm)

* -045, -070 and -090 Units with the flush mount termination must use the 1-1/2" accelerator supplied with the kit.

Table 8

NOTE: Care must be taken to avoid recirculation of exhaust back into intake pipe.

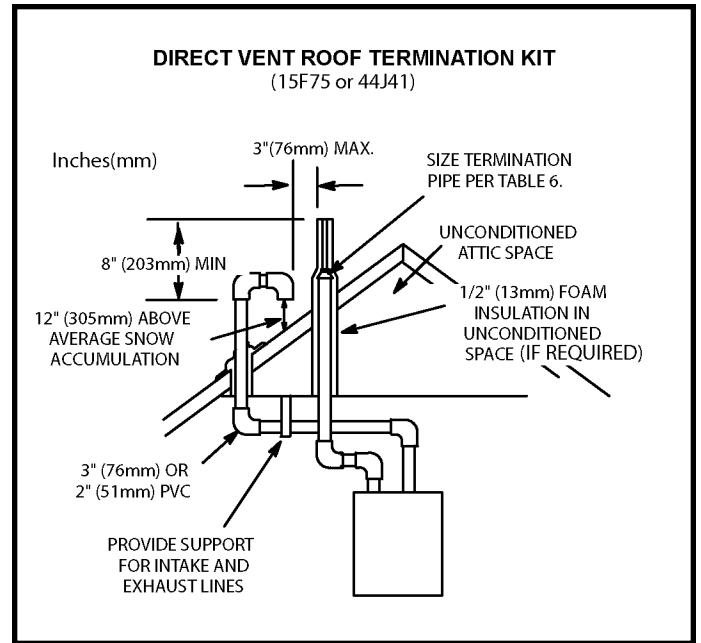

Figure 35

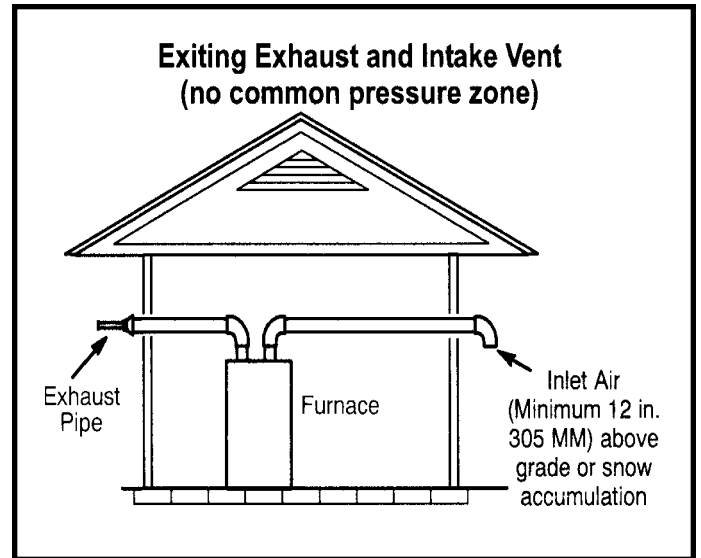

Figure 36

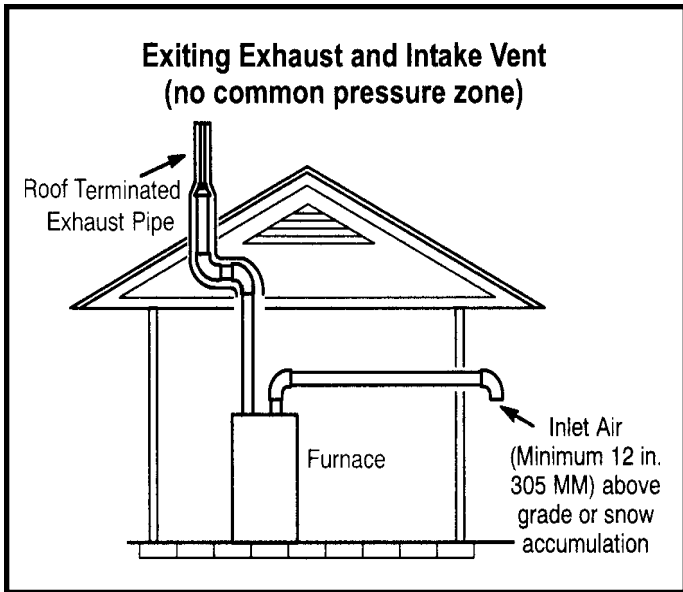

Figure 37

Field Supplied Wall Termination

NOTE – FIELD PROVIDED REDUCER MAY BE REQUIRED TO ADAPT LARGER VENT PIPE SIZE TO TERMINATION

1/2" (13 mm) ARMAFLEX INSULATION IN UNCONDITIONED SPACE (IF REQUIRED)
SIZE TERMINATION PER TABLE 8

STRAIGHT APPLICATION

1/2" (13 mm) ARMAFLEX INSULATION IN UNCONDITIONED SPACE (IF REQUIRED)

EXTENDED APPLICATION

See venting Table 5 for maximum venting lengths with this arrangement.

* Use wall support every 24" (610 mm). Use two wall supports if extension is greater than 24" (610 mm) but less than 48" (1219 mm).
NOTE – One wall support must be 6" (152 mm) from top of each pipe (intake and exhaust)

	2" (51 mm) Vent Pipe	3" (76 mm) Vent Pipe
A – Minimum clearance above grade or average snow accumulation	12" (508 mm)	12" (508 mm)
B – Maximum horizontal separation between intake and exhaust	6" (152 mm)	6" (152 mm)
C – Minimum from end of exhaust to inlet of intake	8" (203 mm)	8" (203 mm)
D – Maximum exhaust pipe length	12" (305 mm)	20" (508 mm)
E – Maximum wall support distance from top of each pipe (intake/exhaust)	6" (152 mm)	6" (152 mm)

Figure 38

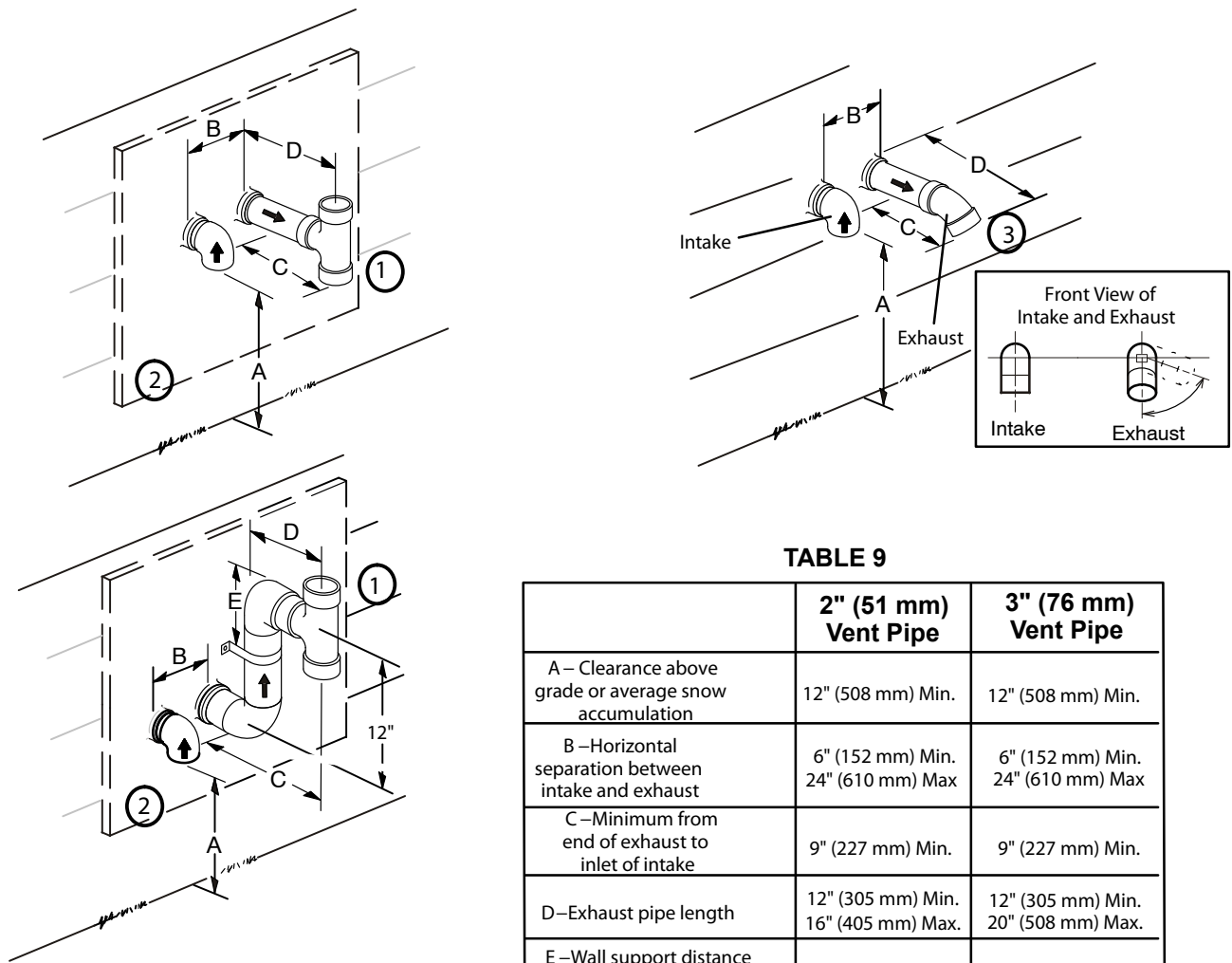

TABLE 9

	2" (51 mm) Vent Pipe	3" (76 mm) Vent Pipe
A – Clearance above grade or average snow accumulation	12" (508 mm) Min.	12" (508 mm) Min.
B – Horizontal separation between intake and exhaust	6" (152 mm) Min. 24" (610 mm) Max	6" (152 mm) Min. 24" (610 mm) Max
C – Minimum from end of exhaust to inlet of intake	9" (227 mm) Min.	9" (227 mm) Min.
D – Exhaust pipe length	12" (305 mm) Min. 16" (405 mm) Max.	12" (305 mm) Min. 20" (508 mm) Max.
E – Wall support distance from top of each pipe (intake/exhaust)	6" (152 mm) Max.	6" (152 mm) Max.

NOTE – See unit installation instructions for proper exhaust pipe termination size reduction.

¹ The exhaust termination tee should be connected to the 2" or 3" PVC flue pipe as shown in the illustration. Do not use an accelerator in applications that include an exhaust termination tee. The accelerator is not required.

² As required. Flue gas may be acidic and may adversely affect some building materials. If a side wall vent termination is used and flue gases will impinge on the building materials, a corrosion-resistant shield (24 inches square) should be used to protect the wall surface. If optional tee is used, the protective shield is recommended. The shield should be constructed using wood, sheet metal or other suitable material. All seams, joints, cracks, etc. in affected area, should be sealed using an appropriate sealant.

³ Exhaust pipe 45° elbow can be rotated to the side away from the combustion air inlet to direct exhaust away from adjacent property. The exhaust must never be directed toward the combustion air inlet.

Figure 39

Field Supplied Wall Termination

NOTE – FIELD PROVIDED REDUCER MAY BE REQUIRED TO ADAPT LARGER VENT PIPE SIZE TO TERMINATION

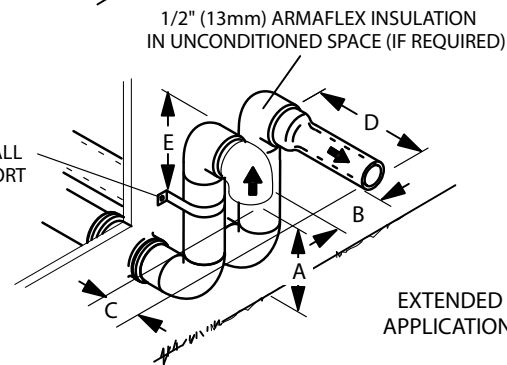
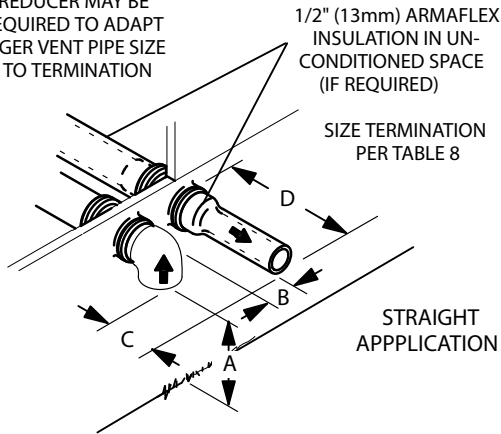

See venting Table 5 for maximum venting lengths with this arrangement.

* Use wall support every 24" (610 mm). Use two wall supports if extension is greater than 24" (610 mm) but less than 48" (1219 mm).
NOTE – One wall support must be 6" (152 mm) from top of each pipe (intake and exhaust)

	2" (51 mm) Vent Pipe	3" (76 mm) Vent Pipe
A – Minimum clearance above grade or average snow accumulation	12" (508 mm)	12" (508 mm)
B – Maximum horizontal separation between intake and exhaust	6" (152 mm)	6" (152 mm)
C – Minimum from end of exhaust to inlet of intake	6" (152 mm)	6" (152 mm)
D – Maximum exhaust pipe length	12" (305 mm)	20" (508 mm)
E – Maximum wall support distance from top of each pipe (intake/exhaust)	6" (152 mm)	6" (152 mm)

Figure 40

- On field supplied terminations for sidewall exit, exhaust piping may extend a maximum of 12 inches (305 mm) for 2" PVC and 20 inches (508 mm) for 3" (76 mm) PVC beyond the outside wall. Intake piping should be as short as possible. See Figures 38 and 40.
- On field supplied terminations, a minimum distance between the end of the exhaust pipe and the end of the intake pipe without a termination elbow is 8" and a minimum distance of 6" with a termination elbow. See Figures 38 and 40.
- If intake and exhaust piping must be run up a side wall to position above snow accumulation or other obstructions, piping must be supported every 24" (610 mm) as shown in Figures 38 and 40. When exhaust and intake piping must be run up an outside wall, the exhaust piping must be terminated with pipe sized per Table 8. The intake piping may be equipped with a 90° elbow turndown. Using turndown will add 5 feet (1.5 m) to the equivalent length of the pipe.
- A multiple furnace installation may use a group of up to four terminations assembled together horizontally, as shown in Figure 44.

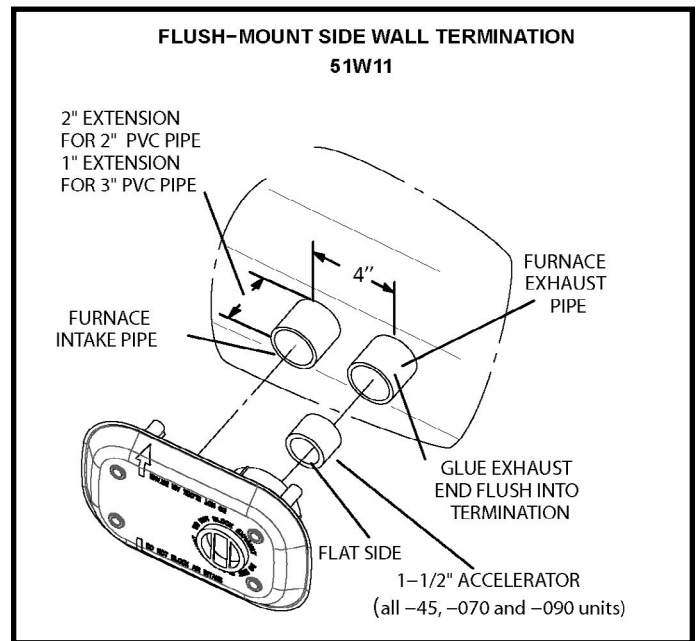

Figure 41

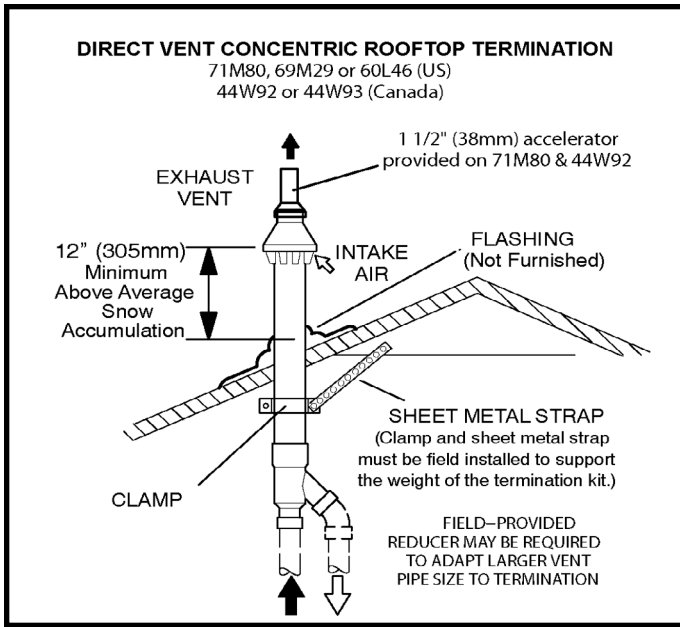

Figure 42

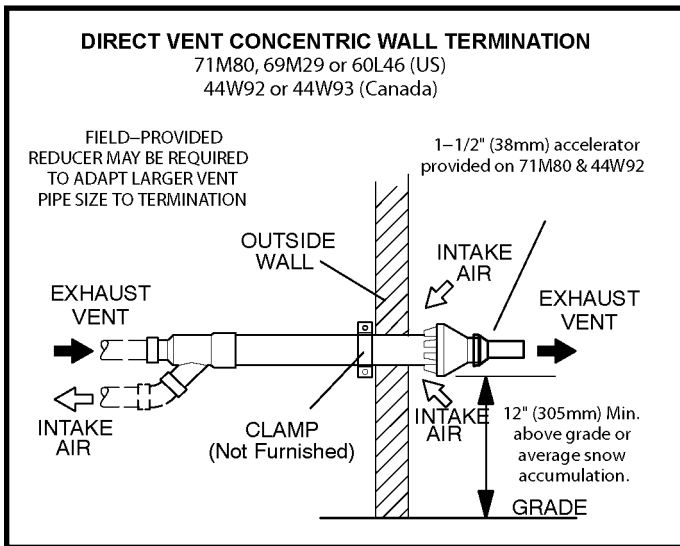

Figure 43

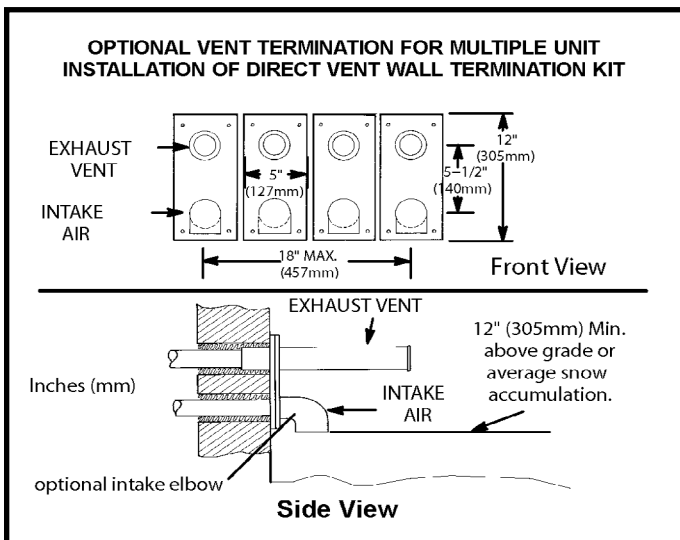

Figure 44

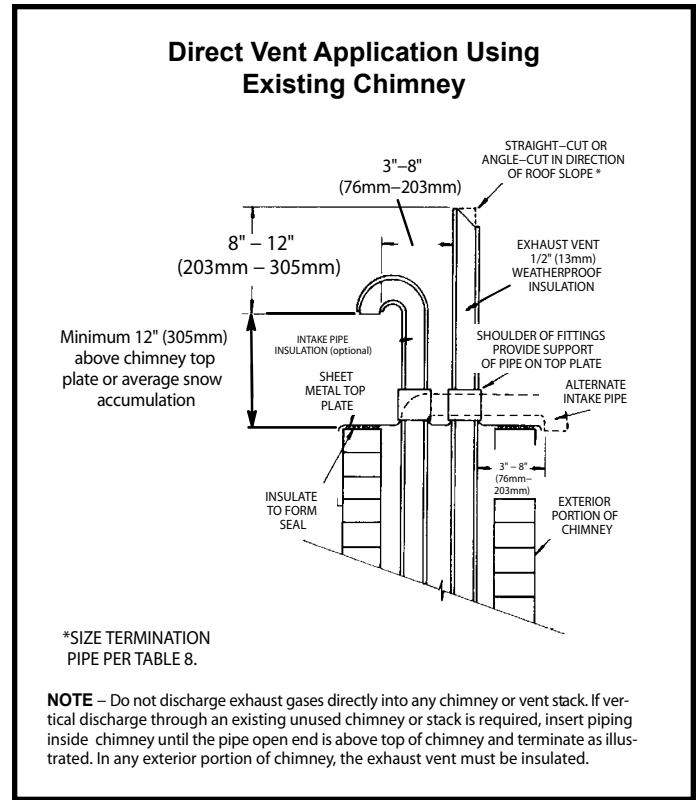

Figure 45

Details of Exhaust Piping Terminations for Non-Direct Vent Applications

Exhaust pipes may be routed either horizontally through an outside wall or vertically through the roof. In attic or closet installations, vertical termination through the roof is preferred. Figures 46 through 49 show typical terminations.

1. Exhaust piping must terminate straight out or up as shown. The termination pipe must be sized as listed in Table 8. The specified pipe size ensures proper velocity required to move the exhaust gases away from the building.
2. On field supplied terminations for side wall exit, exhaust piping may extend a maximum of 12 inches (305 mm) for 2" PVC and 20" (508 mm) for 3" (76 mm) PVC beyond the outside wall. See Figure 47.

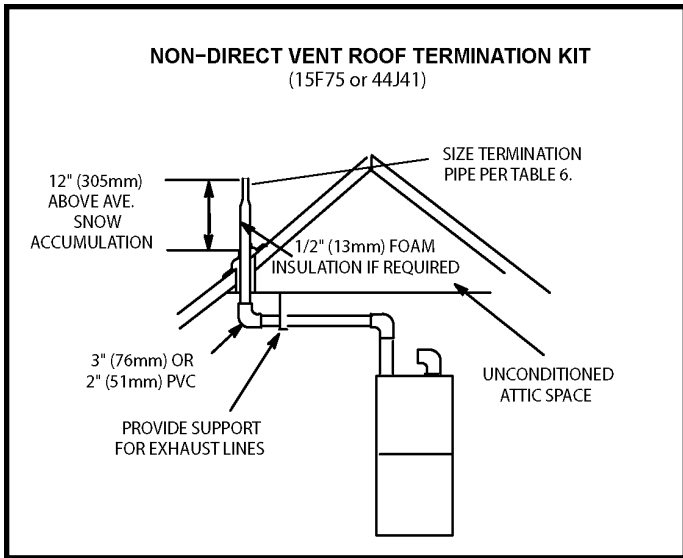

Figure 46

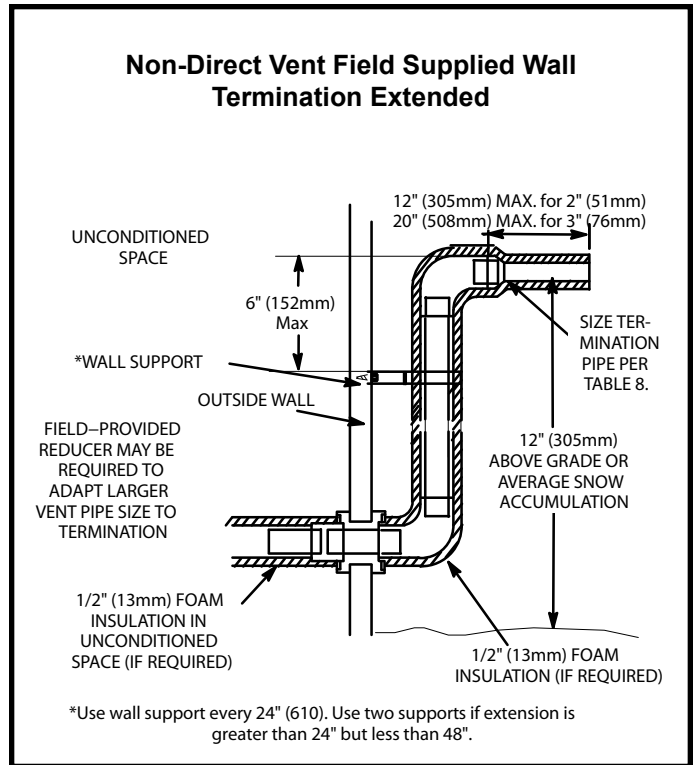

Figure 48

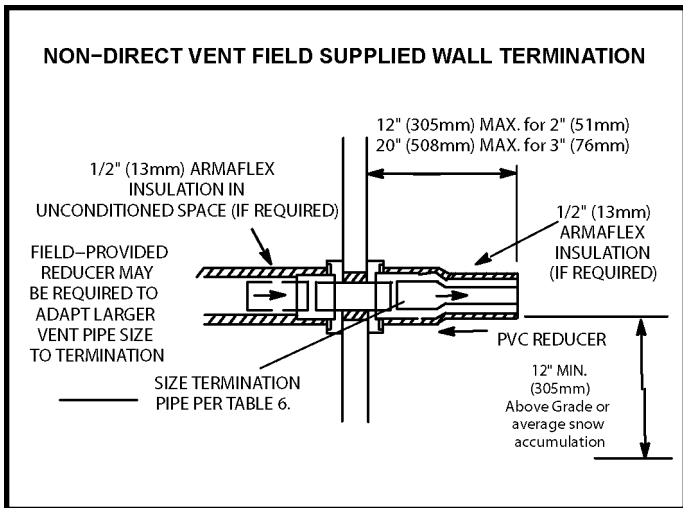

Figure 47

3. If exhaust piping must be run up a sidewall to position above snow accumulation or other obstructions, piping must be supported every 24" (610 mm) as shown in Figure 48. When exhaust piping must be run up an outside wall, any reduction in exhaust pipe size must be done after the final elbow.

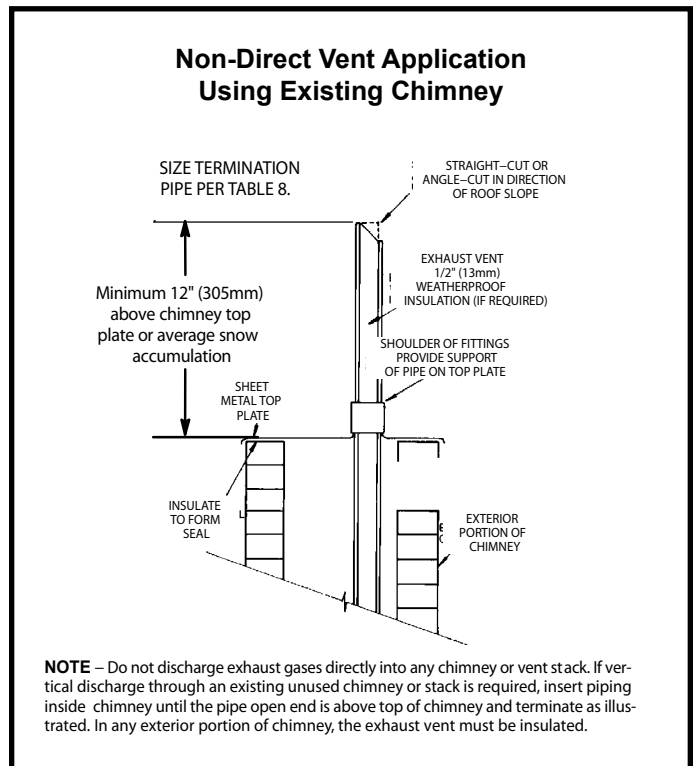

Figure 49

NOTE – Do not discharge exhaust gases directly into any chimney or vent stack. If vertical discharge through an existing unused chimney or stack is required, insert piping inside chimney until the pipe open end is above top of chimney and terminate as illustrated. In any exterior portion of chimney, the exhaust vent must be insulated.

Condensate Piping

This unit is designed for either right or left side exit of condensate piping in upflow applications. In horizontal applications, the condensate trap must extend below the unit. An 8" service clearance is required for the condensate trap. Refer to Figure 50 for condensate trap locations. Figure 57 shows trap assembly using 1/2" PVC or 3/4" PVC.

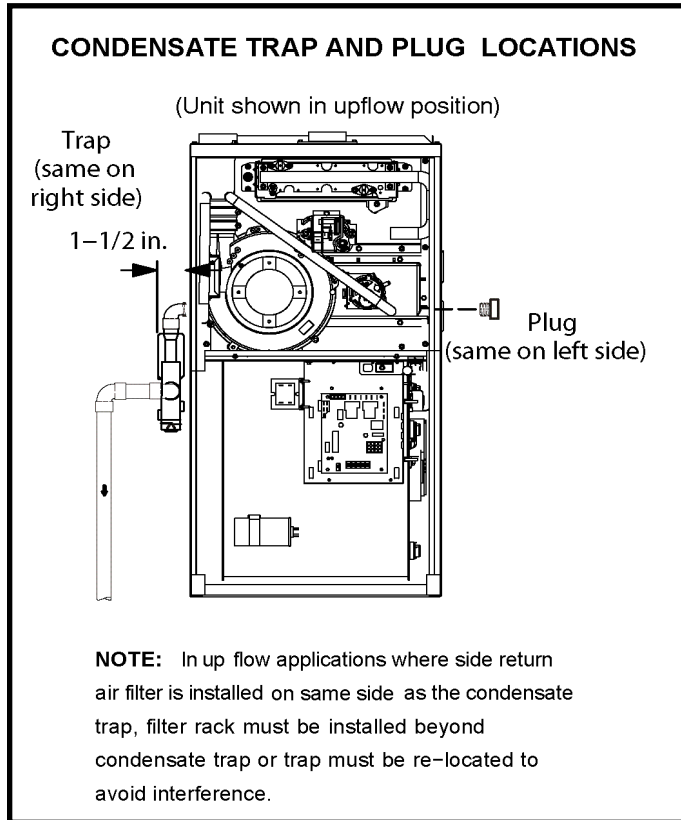

Figure 50

NOTE: If necessary the condensate trap may be installed up to 5' away from the furnace. Use PVC pipe to connect trap to furnace condensate outlet. Piping from furnace must slope down a minimum of 1/4" per ft. toward trap.

1. Determine which side condensate piping will exit the unit, location of trap, field-provided fittings and length of PVC pipe required to reach available drain.
2. Use a large flat head screw driver or a 1/2" drive socket extension and remove plug (Figure 50) from the cold end header box at the appropriate location on the side of the unit. Install provided 3/4 NPT street elbow fitting into cold end header box. Use Teflon tape or appropriate pipe dope.
3. Install the cap over the clean out opening at the base of the trap. Secure with clamp. See Figure 57.

4. Install drain trap using appropriate PVC fittings, glue all joints. Glue the provided drain trap as shown in Figure 57. Route the condensate line to an open drain. *Condensate line must maintain a 1/4" downward slope from the furnace to the drain.*
5. Figures 52 and 53 show the furnace and evaporator coil using a separate drain. If necessary the condensate line from the furnace and evaporator coil can drain together. See Figure 55 and 56.

Upflow furnace (Figure 51) - In upflow furnace applications the field provided vent must be a minimum 1" to a maximum 2" length above the condensate drain outlet connection. Any length above 2" may result in a flooded heat exchanger if the combined primary drain line were to become restricted.

Horizontal furnace (Figure 53) - In horizontal furnace applications the field provided vent must be minimum 4" to a maximum 5" length above the condensate drain outlet connection. Any length above 5" may result in a flooded heat exchanger if the combined primary drain line were to become restricted.

NOTE: In horizontal applications it is recommended to install a secondary drain pan underneath the unit and trap assembly.

NOTE: Vinyl tubing may be used for condensate drain. Tubing must be 1-1/4" o.d. X 1" i.d. and should be attached to the drain on the trap using a hose clamp.

CAUTION

Do not use copper tubing or existing copper condensate lines for drain line.

6. If unit will be started immediately upon completion of installation, prime trap per procedure outlined in Unit Start-Up section.

Condensate line must slope downward away from the trap to drain. If drain level is above condensate trap, condensate pump must be used. Condensate drain line should be routed within the conditioned space to avoid freezing of condensate and blockage of drain line. If this is not possible, a heat cable kit may be used on the condensate trap and line. Heating cable kit is available in various lengths; 6 ft. (1.8 m) - kit no. 26K68; 24 ft. (7.3 m) - kit no. 26K69; and 50 ft. (15.2 m) - kit no. 26K70.

CAUTION

A separate drain line must be run to the drain from the condensate trap to ensure proper drainage and pressure switch operation. DO NOT connect the condensate trap drain into the drain line from the evaporator coil.

Condensate Trap Locations

(Unit shown in upflow position with remote trap)

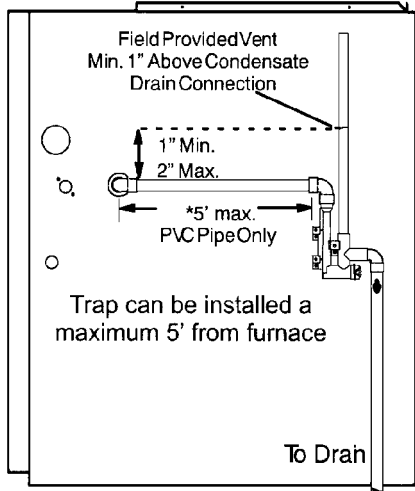

* Piping from furnace must slope down a minimum of 1/4" per ft. toward trap.

Figure 51

Unit with Cooling Coil

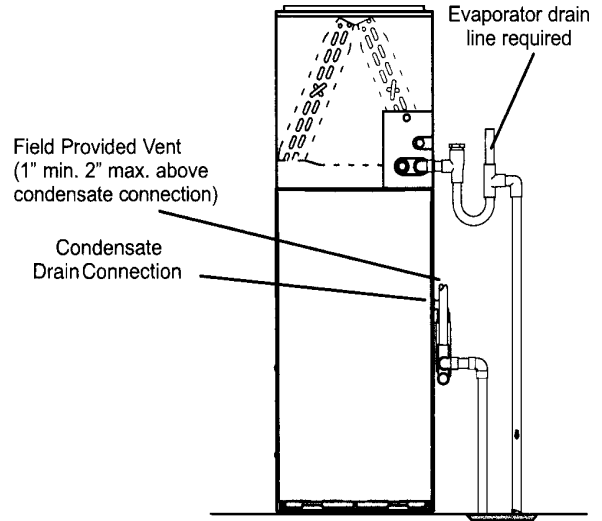
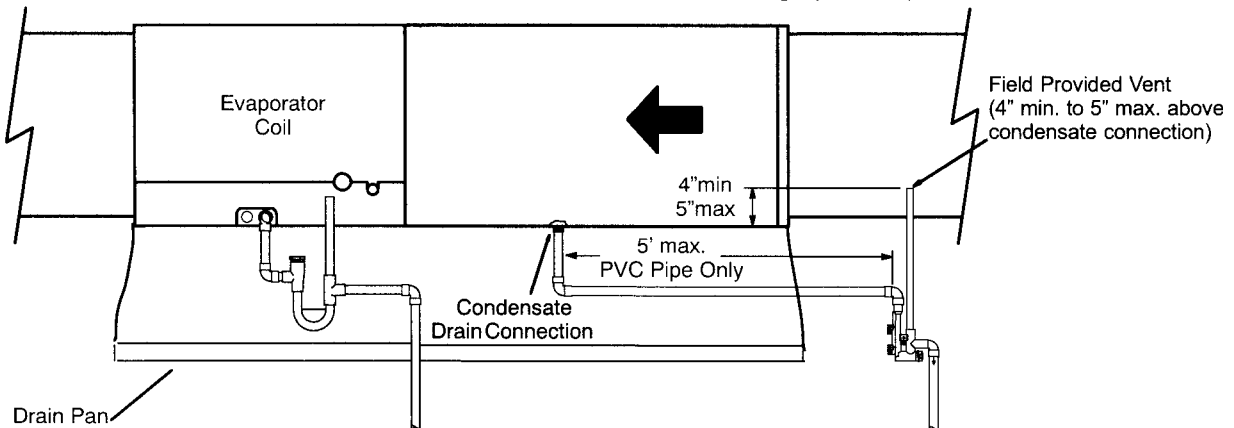

Figure 52

CAUTION

Do not use copper tubing or existing copper condensate lines for drain line.

Condensate Trap Locations



* Piping from furnace must slope down a minimum of 1/4" per ft. toward trap.

Figure 53

WARNING

When combining the furnace and evaporator coil drains together, the A/C condensate drain outlet must be vented to relieve pressure in order for the furnace pressure switch to operate properly.

Condensate Trap with Optional Overflow Switch

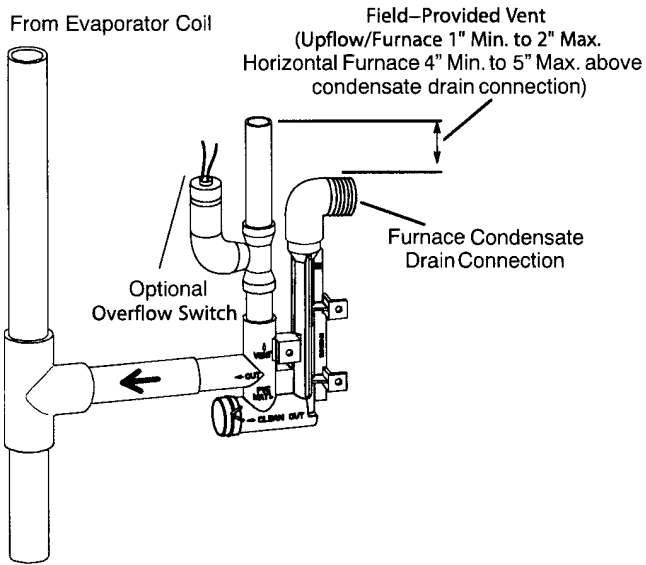

Figure 54

Evaporator Coil Using a Common Drain

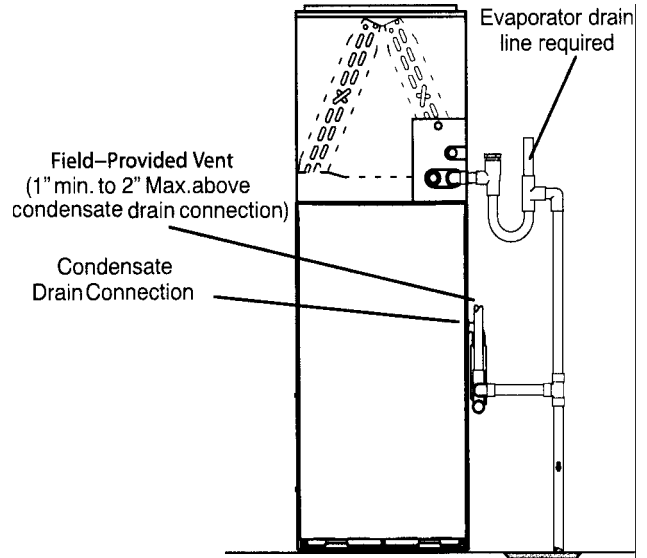
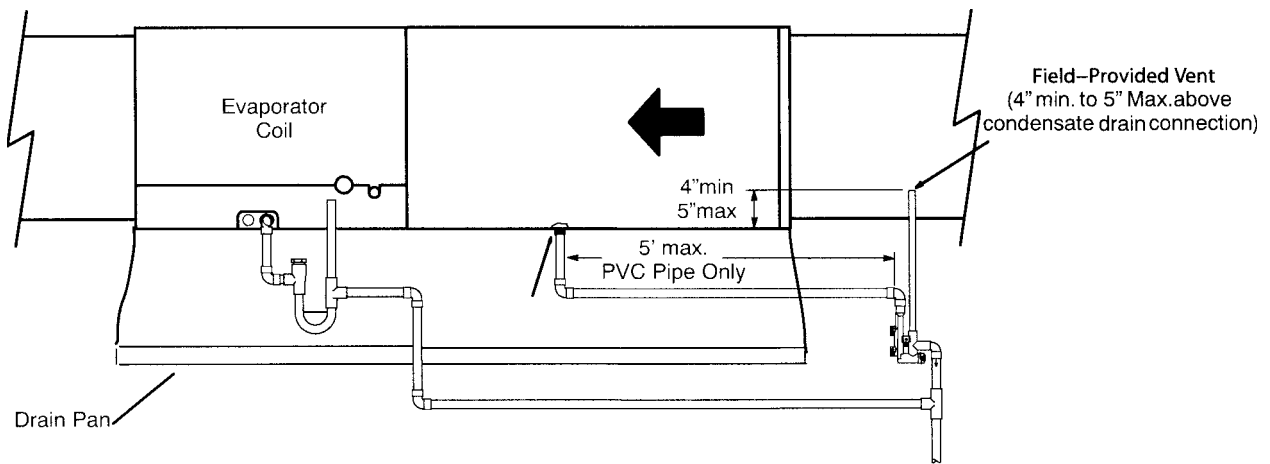

Figure 55

Evaporator Coil Using a Common Drain



Piping from furnace and evaporator coil must slope down a minimum 1/4" per ft. toward trap.

Figure 56

Trap / Drain Assembly Using 1/2" PVC or 3/4" PVC

Optional Condensate Drain Connection

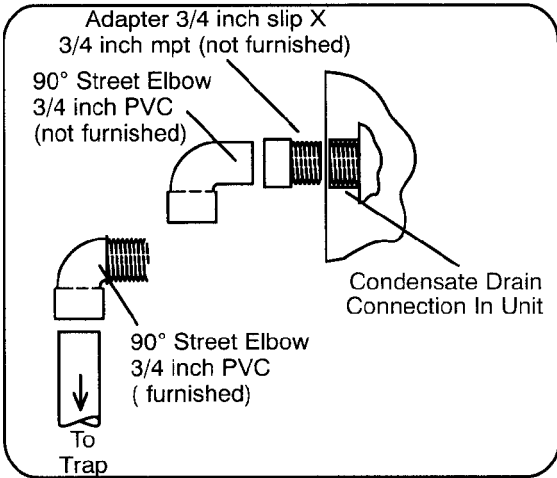

Optional Drain Piping From Trap

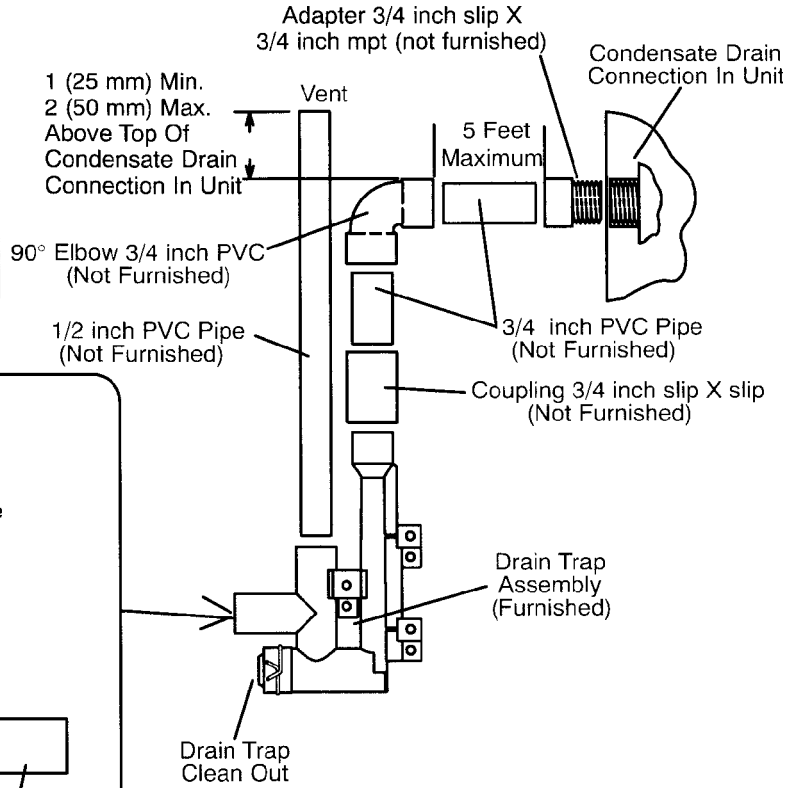
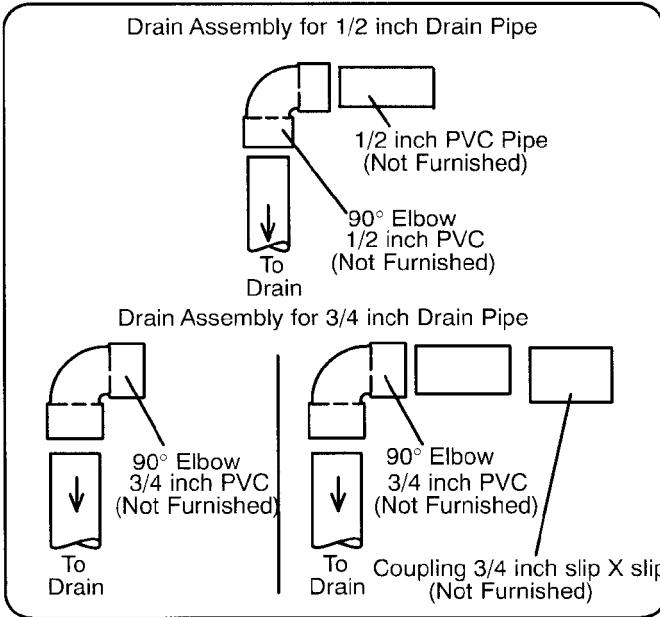

Drain Trap Assembly with 1/2 inch Piping

1 (25 mm) Min. 2 (50 mm) Max. Above Top Of Condensate Drain Connection In Unit

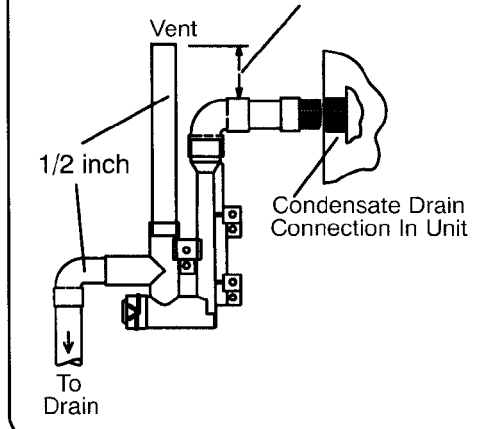

Drain Trap Assembly with 3/4 inch Piping

1 (25 mm) Min. 2 (50 mm) Max. Above Top Of Condensate Drain Connection In Unit

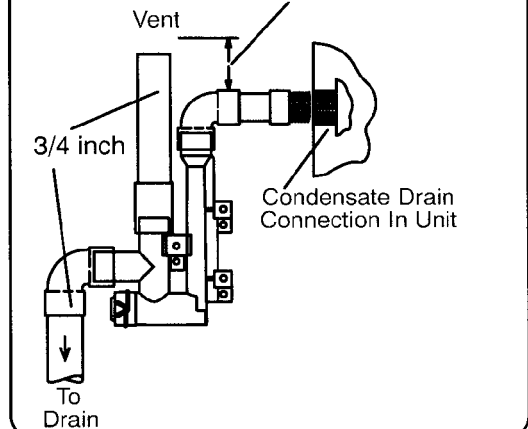

Drain Trap Assembly (Furnished)

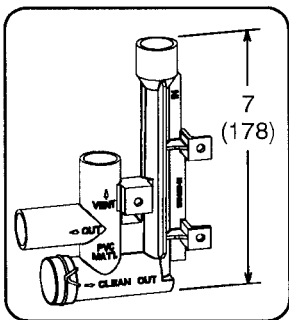

Figure 57

Gas Piping

CAUTION

If a flexible gas connector is required or allowed by the authority that has jurisdiction, black iron pipe shall be installed at the gas valve and extend outside the furnace cabinet. The flexible connector can then be added between the black iron pipe and the gas supply line.

WARNING

Do not exceed 600 in.-lbs. (50 ft.-lbs.) torque when attaching the gas piping to the gas valve.

1. Gas piping may be routed into the unit through either the left or right hand side. Supply piping enters into the gas valve from the side of the valve as shown in Figure 54. Move Bellows grommet to side which gas line enters. Ensure opposite gas line hole is plugged with supplied plug.

IMPORTANT

A low inlet pressure switch in LP/propane applications is recommended.

2. When connecting gas supply, factors such as length of run, number of fittings and furnace rating must be considered to avoid excessive pressure drop. Table 10 list recommended pipe sizes for typical applications.

NOTE: Use two wrenches when connecting gas piping to avoid transferring torque to the manifold.

3. Gas piping must not run in or through air ducts, clothes chutes, chimneys or gas vents, dumb waiters or elevator shafts. Center gas line through piping hole. Gas line should not touch side of unit. See Figures 59 and 60.
4. Piping should be sloped 1/4 " per 15 feet (6 mm per 5.6 m) upward toward the gas meter from the furnace. The piping must be supported at proper intervals, every 8 to 10 feet (2.44 to 3.05 m), using suitable hangers or straps. Install a drip leg in vertical pipe runs to serve as a trap for sediment or condensate.
5. A 1/8" N.P.T. plugged tap or pressure post is located on the gas valve to facilitate test gauge connection. See Figure 67.

6. In some localities, codes may require installation of a manual main shut-off valve and union (furnished by installer) external to the unit. Union must be of the ground joint type.

IMPORTANT

Compounds used on threaded joints of gas piping must be resistant to the actions of liquified petroleum gases.

Leak Check

After gas piping is completed, carefully check all piping connections (factory and field installed) for gas leaks. Use a leak detecting solution or other preferred means.

Never use an open flame to test for gas leaks. Check all connections using a commercially available soap solution made specifically for leak detection.

The furnace must be isolated from the gas supply system by closing its individual manual shut-off valve during any pressure testing of the gas supply system at pressures more than or equal to 1/2 psig (3.48 kPa, 14 inches w.c.).

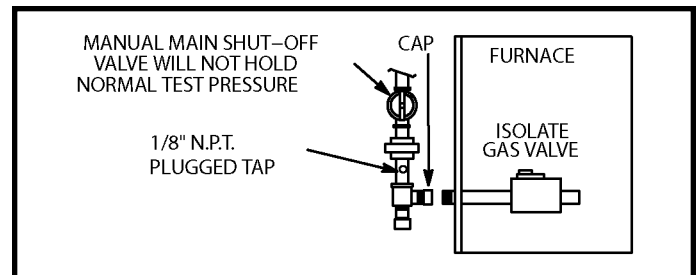

Figure 58

IMPORTANT

When testing pressure of gas lines, gas valve must be disconnected and isolated. See Figure 58. Gas valves can be damaged if subjected to pressures greater than 1/2 psig (3.48 kPa).

WARNING

FIRE OR EXPLOSION HAZARD

Failure to follow the safety warnings exactly could result in serious injury, death, or property damage. Never use an open flame to test for gas leaks. Check all connections using a commercially available soap solution made specifically for leak detection. Some soaps used for leak detection are corrosive to certain metals. Carefully rinse piping thoroughly after leak test has been completed.

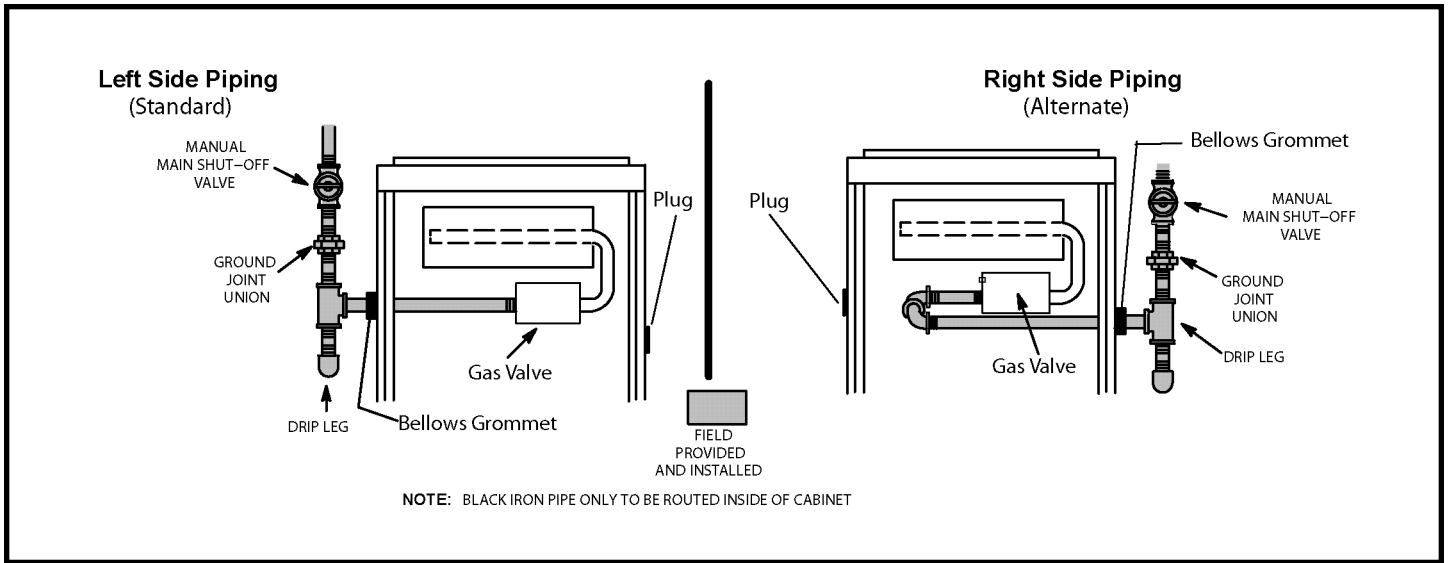

Figure 59

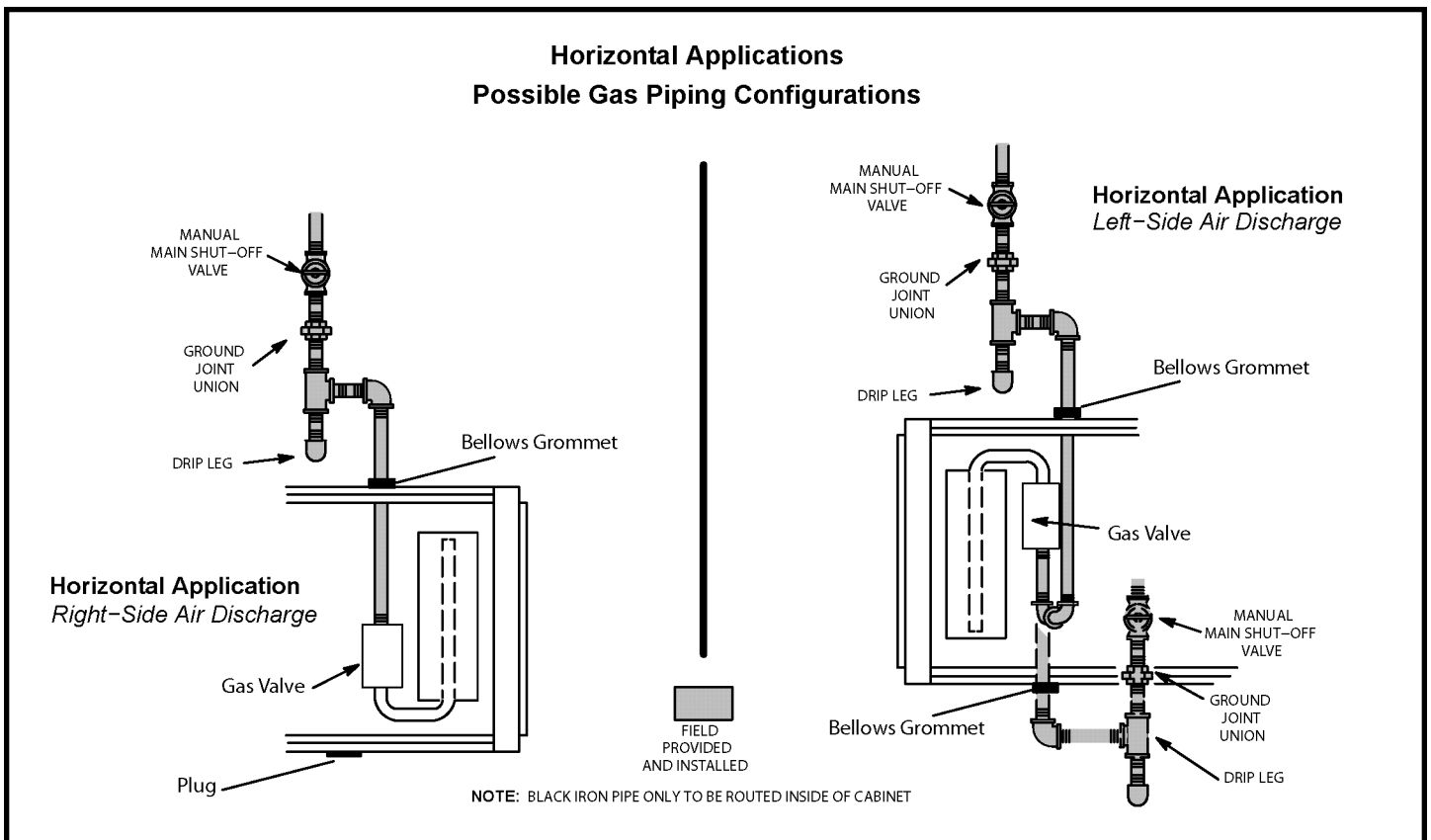

Figure 60

GAS PIPE CAPACITY – FT³/HR (kL/HR)

Nominal Iron Pipe Size Inches(mm)	Internal Diameter Inches(mm)	Length of Pipe–Feet(m)									
		10 (3.048)	20 (6.096)	30 (9.144)	40 (12.192)	50 (15.240)	60 (18.288)	70 (21.336)	80 (24.384)	90 (27.432)	100 (30.480)
1/2 (12.7)	.622 (17.799)	175 (4.96)	120 (3.40)	97 (2.75)	82 (2.32)	73 (2.07)	66 (1.87)	61 (1.73)	57 (1.61)	53 (1.50)	50 (1.42)
3/4 (19.05)	.824 (20.930)	360 (10.19)	250 (7.08)	200 (5.66)	170 (4.81)	151 (4.28)	138 (3.91)	125 (3.54)	118 (3.34)	110 (3.11)	103 (2.92)
1 (25.4)	1.049 (26.645)	680 (19.25)	465 (13.17)	375 (10.62)	320 (9.06)	285 (8.07)	260 (7.36)	240 (6.80)	220 (6.23)	205 (5.80)	195 (5.52)
1–1/4 (31.75)	1.380 (35.052)	1400 (39.64)	950 (26.90)	770 (21.80)	660 (18.69)	580 (16.42)	530 (15.01)	490 (13.87)	460 (13.03)	430 (12.18)	400 (11.33)
1–1/2 (38.1)	1.610 (40.894)	2100 (59.46)	1460 (41.34)	1180 (33.41)	990 (28.03)	900 (25.48)	810 (22.94)	750 (21.24)	690 (19.54)	650 (18.41)	620 (17.56)
2 (50.8)	2.067 (52.502)	3950 (111.85)	2750 (77.87)	2200 (62.30)	1900 (53.80)	1680 (47.57)	1520 (43.04)	1400 (39.64)	1300 (36.81)	1220 (34.55)	1150 (32.56)
2–1/2 (63.5)	2.469 (67.713)	6300 (178.39)	4350 (123.17)	3520 (99.67)	3000 (84.95)	2650 (75.04)	2400 (67.96)	2250 (63.71)	2050 (58.05)	1950 (55.22)	1850 (52.38)
3 (76.2)	3.068 (77.927)	11000 (311.48)	7700 (218.03)	6250 (176.98)	5300 (150.07)	4750 (134.50)	4300 (121.76)	3900 (110.43)	3700 (104.77)	3450 (97.69)	3250 (92.03)
4 (101.6)	4.026 (102.260)	23000 (651.27)	15800 (447.39)	12800 (362.44)	10900 (308.64)	9700 (274.67)	8800 (249.18)	8100 (229.36)	7500 (212.37)	7200 (203.88)	6700 (189.72)

NOTE: Capacity given in cubic feet of gas per hour (kilo liters of gas per hour) and based on 0.60 specific gravity gas.

Table 10

Electrical

ELECTROSTATIC DISCHARGE (ESD) Precautions and Procedures



Electrostatic discharge can affect electronic components. Take precautions during furnace installation and service to protect the furnace's electronic controls. Precautions will help to avoid control exposure to electrostatic discharge by putting the furnace, the control and the technician at the same electrostatic potential. Neutralize electrostatic charge by touching hand and all tools on an unpainted unit surface, such as the gas valve or blower deck, before performing any service procedure.

INTERIOR MAKE-UP BOX INSTALLATION

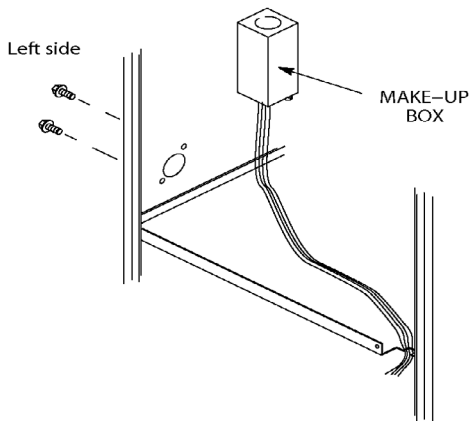

Figure 61

INTERIOR MAKE-UP BOX INSTALLATION

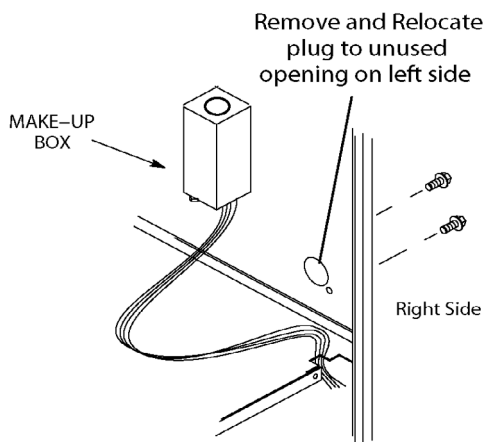

Figure 62

The unit is equipped with a field makeup box. The makeup box may be moved to the right side of the furnace to facilitate installation. Seal unused openings on left side with plugs removed from right side. Secure the excess wire to the existing harness to protect it from damage.

Refer to Figure 64 for field wiring and Figure 65 for schematic wiring diagram and troubleshooting.

The power supply wiring must meet Class I restrictions. Protected by either a fuse or circuit breaker, select circuit protection and wire size according to unit nameplate.

NOTE: *Unit nameplate states maximum current draw. Maximum Over-Current Protection allowed is 15 AMP.*

Holes are on both sides of the furnace cabinet to facilitate wiring.

Install a separate (properly sized) disconnect switch near the furnace so that power can be turned off for servicing.

Before connecting the thermostat check to make sure the wires will be long enough for servicing at a later date. Make sure that thermostat wire is long enough to facilitate future removal of blower for service.

Complete the wiring connections to the equipment. Use the provided unit wiring diagram and the field wiring diagram shown in Figure 64. Use 18 gauge wire or larger that is suitable for Class II rating for thermostat connections.

Electrically ground the unit according to local codes or, in the absence of local codes, according to the current National Electric Code (ANSI/HFPA No. 70) for the USA and current Canadian Electric Code Part 1 (CSA standard C22.1) for Canada. A green ground wire is provided in the field makeup box.

NOTE: *The gas furnace contains electronic components that are polarity sensitive. Make sure that the furnace is wired correctly and is properly grounded.*

Accessory Terminals

One line voltage "EAC" 1/4" spade terminal is provided on the furnace control board. Any accessory rated up to one amp can be connected to this terminal with the neutral leg of the circuit being connected to one of the provided neutral terminals. If an accessory rated at greater than one amp is connected to this terminal, it is necessary to use an external relay. See Figure 66 for control board configuration. This terminal is energized when the indoor blower is operating.

One line voltage "HUM" 1/4" spade terminal is provided on the furnace control board. Any humidifier rated up to one amp can be connected to this terminal with the neutral leg of the circuit being connected to one of the provided neutral

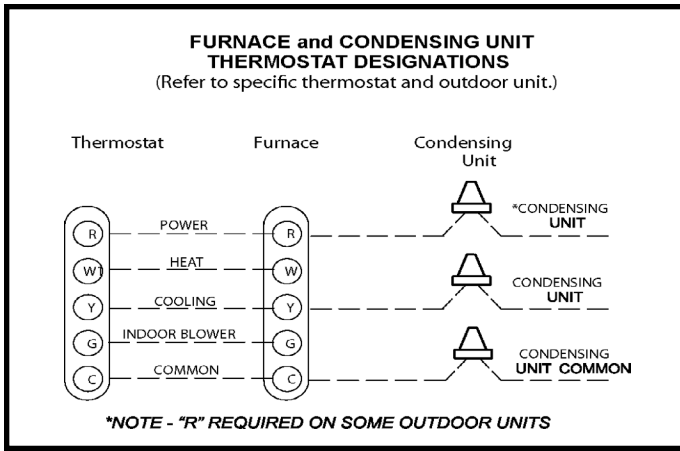

Figure 63

terminals. If a humidifier rated at greater than one amp is connected to this terminal, it is necessary to use an external relay. See Figure 66 for control board configuration. This terminal is energized in the heating mode when the combustion air inducer is operating.

One 24V "H" 1/4" spade terminal is provided on the furnace control board. Any humidifier rated up to 0.5 amp can be connected to this terminal with the ground leg of the circuit connected to ground or the "C" terminal. See Figure 66 for control board configuration. This terminal is energized in the heating mode when the combustion air inducer is operating.

Install the room thermostat according to the instructions provided with the thermostat. See Figure 63 for thermostat designations. If the furnace is being matched with a heat pump, refer to the FM21 installation instruction or appropriate dual fuel thermostat instructions.

Indoor Blower Speeds

1. When the thermostat is set to "FAN ON", the indoor blower will run continuously on the fan speed when there is no cooling or heating demand.
2. When the furnace is running in the heating mode, the indoor blower will run on the heating speed.
3. When there is a cooling demand, the indoor blower will run on the cooling speed.

Generator Use - Voltage Requirements

- The furnace requires 120 volts \pm 10% (Range: 108 volts to 132 volts)
- The furnace operates at 60 Hz \pm 5% (Range: 57 Hz to 63 Hz)
- The furnace integrated control requires both proper polarity and proper ground. Both polarity and proper grounding should be checked before attempting to operate the furnace on either permanent or temporary power.
- Generator should have a wave form distortion of less than 5% THD (total harmonic distortion).

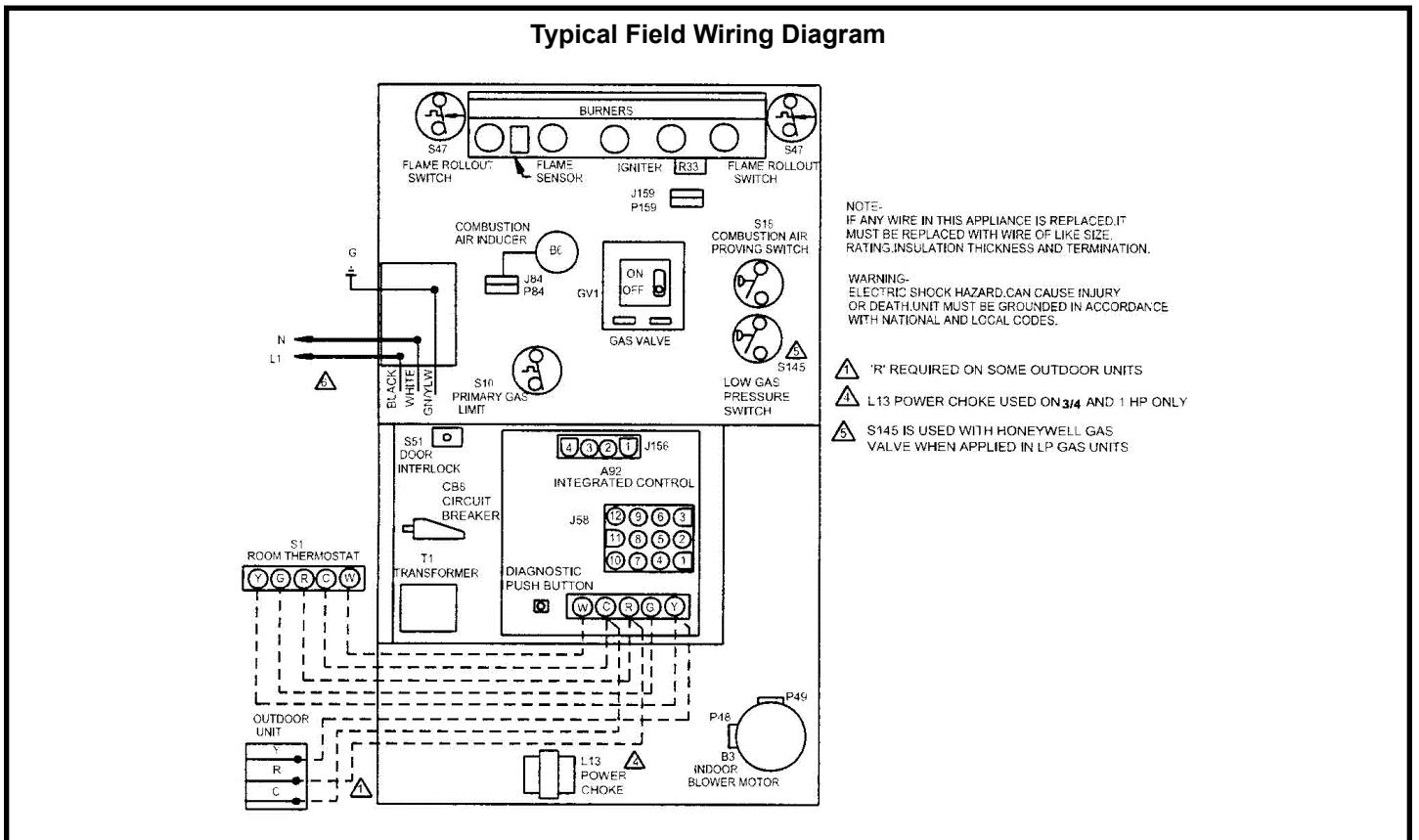

Figure 64

TYPICAL WIRING DIAGRAM

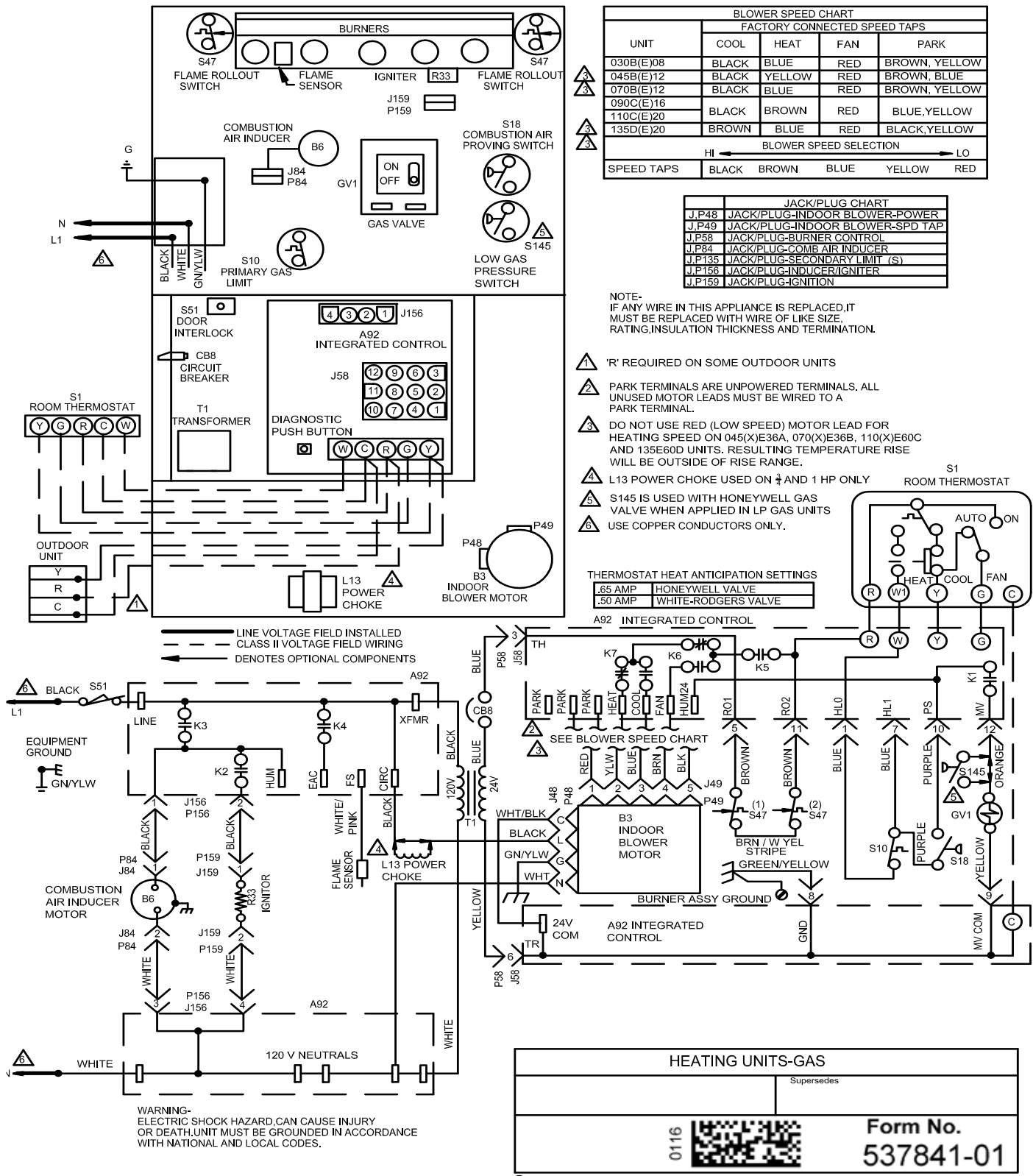
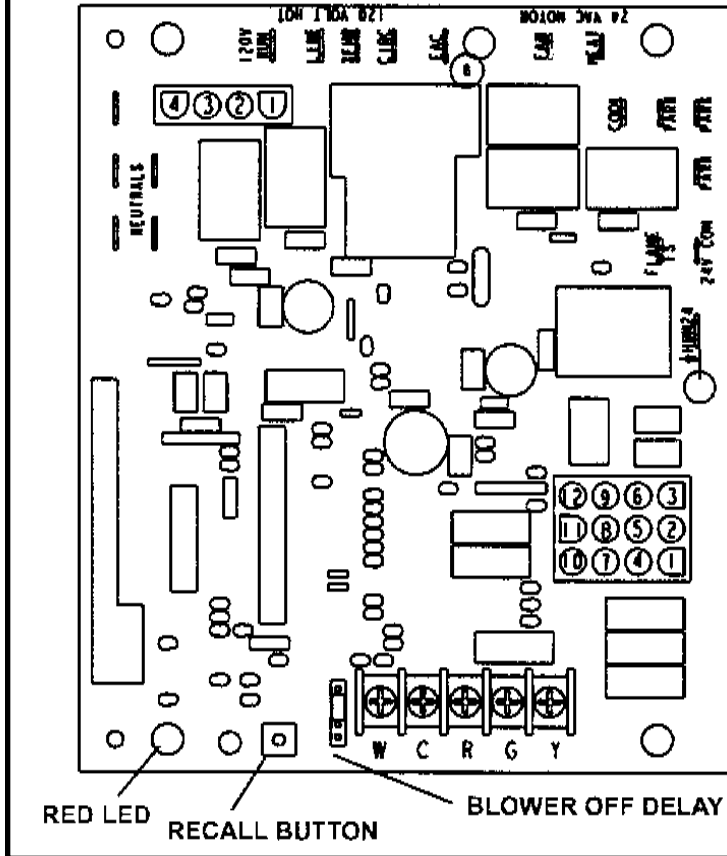

Figure 65

**INTEGRATED CONTROL
(Automatic Hot Surface Ignition System)**



Terminal Designations	
120 HUM	Humidifier (120 VAC)
LINE	Input (120 VAC)
XFMR	Transformer (120 VAC)
CIRC	Indoor Blower (120 VAC)
EAC	Electronic Air Cleaner (120 VAC)
COOL	Blower - Cooling Speed (24 VAC)
HEAT	Blower - Heating Speed (24 VAC)
FAN	Blower - Fan Speed (24 VAC)
PARK	Dead Terminals to Park all Speed Taps
NEUTRALS	Neutral Terminals (120 VAC)
FS	Flame Sense
24 COM	Common (24 VAC)
HUM 24	Humidifier (24 VAC)

Figure 66

Unit Start-Up

FOR YOUR SAFETY READ BEFORE OPERATING

⚠ WARNING

Do not use this furnace if any part has been underwater. A flood-damaged furnace is extremely dangerous. Attempts to use the furnace can result in fire or explosion. Immediately call a qualified service technician to inspect the furnace and to replace all gas controls, control system parts, and electrical parts that have been wet or to replace the furnace, if deemed necessary.

⚠ WARNING



Danger of explosion. Can cause injury or product or property damage. Should the gas supply fail to shut off or if overheating occurs, shut off the gas valve to the furnace before shutting off the electrical blower deck, before performing any service procedure.

⚠ CAUTION

Before attempting to perform any service or maintenance, turn the electrical power to unit OFF at disconnect switch.

BEFORE LIGHTING the unit, smell all around the furnace area for gas. Be sure to smell next to the floor because some gas is heavier than air and will settle on the floor.

The gas valve on the unit is equipped with a gas control switch (lever). Use only your hand to move switch. Never use tools. If the switch will not move by hand, do not try to repair it. Force or attempted repair may result in a fire or explosion.

Placing the furnace into operation:

This furnace is equipped with an automatic hot surface ignition system. Do not attempt to manually light burners on this furnace. Each time the thermostat calls for heat, the burners will automatically light. The ignitor does not get hot when there is no call for heat on these units.

Priming Condensate Trap

The condensate trap should be primed with water prior to start-up to ensure proper condensate drainage. Either pour 10 fl. oz. (300 ml) of water into the trap, or follow these steps to prime the trap:

1. Follow the lighting instructions to place the unit into operation.
2. Set the thermostat to initiate a heating demand.
3. Allow the burners to fire for approximately 3 minutes.
4. Adjust the thermostat to deactivate the heating demand.
5. Wait for the combustion air inducer to stop. Set the thermostat to initiate a heating demand and again allow the burners to fire for approximately 3 minutes.
6. Adjust the thermostat to deactivate the heating demand and wait for the combustion air inducer to stop. At this point, the trap should be primed with sufficient water to ensure proper condensate drain operation.

WARNING

If you do not follow these instructions exactly, a fire or explosion may result causing property damage, personal injury or death.

Gas Valve Operation (Figure 67)

1. **STOP!** Read the safety information at the beginning of this section.
2. Set the thermostat to the lowest setting.
3. Turn **OFF** all electrical power to the unit.
4. This furnace is equipped with an ignition device which automatically lights the burners. Do **not** try to light the burners by hand.
5. Remove the upper access panel.
6. Move gas valve switch to **OFF**. See Figure 67.
7. Wait five minutes to clear out any gas. If you then smell gas, **STOP!** Immediately call your gas supplier from a neighbor's phone. Follow the gas supplier's instructions. If you do not smell gas go to next step.
8. Move gas valve switch to **ON**. See Figure 67.

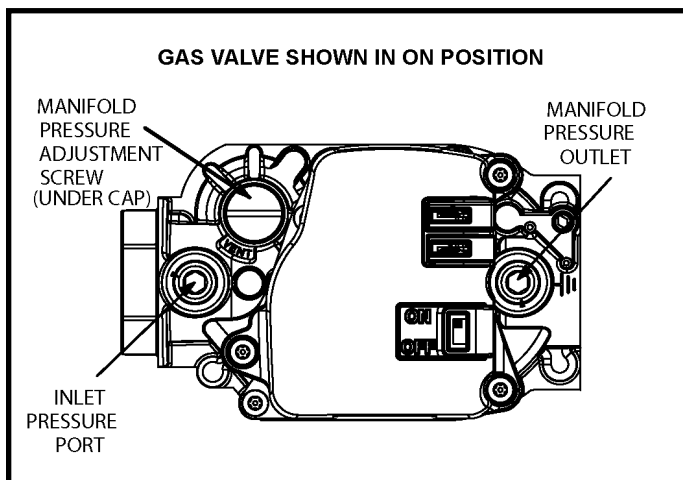

Figure 67

9. Replace the upper access panel.
10. Turn on all electrical power to the unit.
11. Set the thermostat to desired setting.

NOTE: When unit is initially started, steps 1 through 11 may need to be repeated to purge air from gas line.

12. If the appliance will not operate, follow the instructions "Turning Off Gas to Unit" and call your service technician or gas supplier.

Turning Off Gas to Unit

1. Set the thermostat to the lowest setting.
2. Turn off all electrical power to the unit if service is to be performed.
3. Remove the upper access panel.
4. Move gas valve switch to **OFF**.
5. Replace the upper access panel.

Failure To Operate

If the unit fails to operate, check the following:

1. Is the thermostat calling for heat?
2. Are access panels securely in place?
3. Is the main disconnect switch closed?
4. Is there a blown fuse or tripped breaker?
5. Is the filter dirty or plugged? Dirty or plugged filters will cause the limit control to shut the unit off.
6. Is gas turned on at the meter?
7. Is the manual main shut-off valve open?
8. Is the internal manual shut-off valve open?
9. Is the unit ignition system in lockout? If the unit locks out again, inspect the unit for blockages.

Heating Sequence Of Operation

1. When thermostat calls for heat, combustion air inducer starts.
2. Combustion air pressure switch proves blower operation. Switch is factory set and requires no adjustment.
3. After a 15 second prepurge, the hot surface ignitor energizes.
4. After a 20 second ignitor warm-up period, the gas valve solenoid opens. A 4-second "Trial for Ignition" period begins.
5. Gas is ignited, flame sensor proves the flame, and the combustion process continues.
6. If flame is not detected after first ignition trial, the ignition control will repeat steps 3 and 4 four more times before locking out the gas valve. The ignition control will then automatically repeat steps 1 through 6 after 60 minutes. To interrupt the 60 minute period, move thermostat from "Heat" to "OFF" then back to "Heat". Heating sequence then restarts at step 1.

Gas Pressure Adjustment

Gas Flow (Approximate)

GAS METER CLOCKING CHART				
MODEL	Seconds for One Revolution			
	Natural		LP	
	1 cu ft Dial	2 cu ft Dial	1 cu ft Dial	2 cu ft Dial
-30	120	240	300	600
-45	80	160	200	400
-70	55	110	136	272
-110	33	66	82	164
-135	27	54	68	136
Natural-1000 btu/cu ft LP-2500 btu/cu ft				

Table 11

Furnace should operate at least 5 minutes before checking gas flow. Determine time in seconds for **two** revolutions of gas through the meter. (Two revolutions assures a more accurate time.) **Divide by two** and compare to time in Table 11. If manifold pressure matches Table 12 and rate is incorrect, check gas orifices for proper size and restriction. Remove temporary gas meter if installed.

NOTE: To obtain accurate reading, shut off all other gas appliances connected to meter.

Supply Pressure Measurement

When testing supply gas pressure, use the 1/8" N.P.T. plugged tap or pressure post located on the gas valve to facilitate test gauge connection. See Figure 67. Check gas line pressure with unit firing at maximum rate. Low pressure may result in erratic operation or underfire. High pressure can result in permanent damage to gas valve or overfire.

On multiple unit installations, each unit should be checked separately, with and without other units operating. Supply pressure must fall within range listed in Table 12.

Manifold Pressure Measurement

1. Remove the threaded plug from the outlet side of the gas valve and install a field provided barbed fitting. Connect to a manometer to measure manifold pressure.
2. Start unit and allow 5 minutes for unit to reach steady state.

Manifold and Supply Line Pressure 0-10,000ft.

Unit	Gas	Manifold Pressure in. wg.					Supply Line Pressure in. w.g. 0 - 10000 ft.	
		0-4500 ft.	4501-5500 ft.	5501-6500 ft.	6501 - 7500ft.	7501 - 10000ft.		
All Sizes	Natural	3.5	3.3	3.2	3.1	3.5	4.5	13.0
	LP/propane	10.0	9.4	9.1	8.9	10.0	11.0	13.0

NOTE - A natural to L.P. propane gas changeover kit is necessary to convert this unit. Refer to the changeover kit installation instruction for the conversion procedure.

Table 12

3. While waiting for the unit to stabilize, observe the flame. Flame should be stable and should not lift from burner. Natural gas should burn blue.
4. After allowing unit to stabilize for 5 minutes, record manifold pressure and compare to value given in Table 12.

NOTE: Shut unit off and remove manometer as soon as an accurate reading has been obtained. Take care to remove barbed fitting and replace threaded plug.

Proper Combustion

Furnace should operate minimum 15 minutes with correct manifold pressure and gas flow rate before checking combustion. Take combustion sample beyond the flue outlet and compare to the tables below.

Unit	CO ₂ % for Nat	CO ₂ % for L.P.
All	7.2 - 7.9	8.6 - 9.3

The maximum carbon monoxide reading should not exceed 100 ppm.

Table 13

High Altitude Information

NOTE: In Canada, certification for installations at elevations over 4500 feet (1371 m) is the jurisdiction of local authorities.

Units may be installed at altitudes up to 10,000 ft. above sea level. See table 12 for de-rate manifold values. Units installed at altitude of 7501 - 10,000 feet require an orifice change. Units installed at altitudes of 4,501 - 10,000 feet (1371 -3048 m) may require a pressure switch change which can be ordered separately.

Table 14 lists required pressure switch changes and orifice conversion kits at varying altitudes.

The combustion air pressure switches are factory set and require no adjustment.

Burner Orifice Conversion Kits at Varying Altitudes				
Unit Size	0-7,500 ft (0-2,286m)		7,501 - 10,000 ft (2,286 - 3,048 m)	
	Natural to LP/Propane	LP/Propane to Natural	High Altitude Natural Burner Orifice Kit	High Altitude LP/Propane Burner Orifice Kit
045	11K50+	73W80*	51W01	11K45+
070				
090				
110				
135				
030	14U96+	N/A	N/A	N/A
<p>* Conversion requires installation of a gas valve regulator spring which is provided with the gas conversion kit. + LP Kits include low line pressure switch.</p>				

A95 and 95G1 Pressure Switch Requirements at Varying Altitudes

Unit Size	0 - 4500 ft (0 - 1,371m)	4501 - 7500 ft (1371 - 2286m)	7501 - 10000 ft (2286 - 3048m)
030/045	No Change	No Change	11J09
070	No Change	11J12	10U93
090	No Change	11J11	10U93
110	No Change	11J12	10U93
135	No Change	11J11	10U93

Pressure switch is factory set. No adjustment necessary. All models use the factory-installed pressure switch from 0-4500 feet (0-1371 m).

Table 14

Testing for Proper Venting and Sufficient Combustion Air for Non-Direct Vent Applications



CARBON MONOXIDE POISONING HAZARD

Failure to follow the steps outlined below for each appliance connected to the venting system being placed into operation could result in carbon monoxide poisoning or death.

The following steps shall be followed for each appliance connected to the venting system being placed into operation, while all other appliances connected to the venting system are not in operation.

After the gas furnace has been started, the following test should be conducted to ensure proper venting and sufficient combustion air has been provided to the unit as well as to other gas-fired appliances which are separately vented.

If this furnace replaces a Category I furnace which was commonly vented with another gas appliance, the size of the existing vent pipe for that gas appliance must be checked. Without the heat of the original furnace flue products, the existing vent pipe is probably oversized for the single water heater or other appliance. The vent should be checked for proper draw with the remaining appliance.

The test should be conducted while all appliances (both in operation and those not in operation) are connected to the venting system being tested. If the venting system has been installed improperly, or if provisions have not been made for sufficient amounts of combustion air, corrections must be made as outlined in the previous section.

1. Seal any unused openings in the venting system.
2. Visually inspect the venting system for proper size and horizontal pitch. Determine there is no blockage or restriction, leakage, corrosion, or other deficiencies which could cause an unsafe condition.
3. To the extent that it is practical, close all building doors and windows and all doors between the space in which the appliances connected to the venting system are located and other spaces of the building.
4. Close fireplace dampers.
5. Turn on clothes dryers and any appliances not connected to the venting system. Turn on any exhaust fans, such as range hoods and bathroom exhausts, so they will operate at maximum speed. Do not operate a summer exhaust fan.
6. Follow the lighting instruction to place the appliance being inspected into operation. Adjust thermostat so appliance will operate continuously.
7. Use the flame of match or candle to test for spillage of flue gases at the draft hood relief opening after 5 minutes of main burner operation.
8. If improper venting is observed during any of the above tests, the venting system must be corrected or sufficient combustion/makeup air must be provided. The venting system should be re-sized to approach the minimum size as determined by using the appropriate tables in appendix G in the current standards of the National Fuel Gas Code ANSI-Z223.1/NPFA 54 in the U.S.A., and the appropriate Natural Gas and Propane appliances venting sizing tables in the current standard of the CSA-B149 Natural Gas and Propane Installation Codes in Canada.
9. After determining that each appliance remaining connected to the common venting system properly vents when tested as indicated in step 3, return doors, windows, exhaust fans, fireplace dampers and any other gas burning appliance to their previous condition of use.

Other Unit Adjustments

Primary Limit

The primary limit is located on the heating compartment vestibule panel. This limit is factory set and requires no adjustment.

Flame Rollout Switches (Two)

These manually reset switches are located on the front of the burner box. These limits are factory set and require no adjustment.

Pressure Switch

The pressure switch is located in the heating compartment on the cold end header box. This switch checks for proper combustion air inducer operation before allowing ignition trial. The switch is factory set and must not be adjusted.

Temperature Rise

After the furnace has been started and supply and return air temperatures have been allowed to stabilize, check the temperature rise. If necessary, adjust the blower speed to maintain the temperature rise within the range shown on the unit nameplate. Increase the blower speed to decrease the temperature. Decrease the blower speed to increase the temperature rise. Failure to adjust the temperature rise may cause erratic limit operation.

Fan Control

The fan ON time of 30 seconds is not adjustable. The fan OFF delay (amount of time that the blower operates after the heat demand has been satisfied) may be adjusted by changing the jumper position across the five pins on the integrated control. The unit is shipped with a factory heat fan OFF setting of 90 seconds. The fan OFF delay affects comfort and is adjustable to satisfy individual applications. Adjust the fan OFF delay to achieve a supply air temperature between 90° and 110° F at the moment that the blower is de-energized. Longer OFF delay settings provide lower return air temperatures; shorter settings provide higher return air temperatures. See Figure 68.

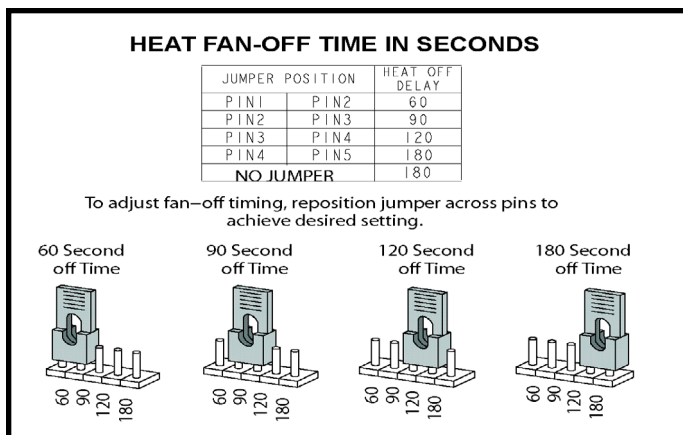

Figure 68

Constant Torque Motor

These units are equipped with a constant torque ECM motor. It has a DC motor coupled to an electronic control module both contained in the same motor housing. The motor is programmed to provide constant torque at each of the five selectable speeds. The motor has five speed taps. Each tap requires 24 volts to energize.

Thermostat Heat Anticipation

Set the heat anticipator setting (if adjustable) according to the amp draw listed on the wiring diagram that is attached to the unit.

Electrical

1. Check all wiring for loose connections.
2. Check for the correct voltage at the furnace (with furnace operating). Correct voltage is 120 VAC \pm 10%
3. Check amp-draw on the blower motor with the blower access panel in place.

Motor Nameplate _____ Actual _____

Blower Speeds

Follow the steps below to change the blower speeds.

1. Turn off electrical power to furnace.
2. Remove blower access panel.
3. Disconnect existing speed tap at control board speed terminal.

NOTE: Termination of any unused motor leads must be insulated.

4. Place unused blower speed tap on integrated control "PARK" terminal or insulate.
5. Refer to blower speed selection chart on unit wiring diagram for desired heating or cooling speed. See Blower performance data beginning on the next page.
6. Connect selected speed tap at control board speed terminal.
7. Re-secure blower access panel.
8. Turn on electrical power to furnace.
9. Recheck temperature rise.

Electronic Ignition

The integrated control has an added feature of an internal Watchguard control. The feature serves as an automatic reset device for integrated control lockout caused by ignition failure. This type of lockout is usually due to low gas line pressure. After one hour of continuous thermostat demand for heat, the Watchguard will break and remake thermostat demand to the furnace and automatically reset the integrated control to begin the ignition sequence.

Blower Data A95UH1E & 95G1UHE

A95UH1E / 95G1UHE 045*B12 PERFORMANCE (Less Filter)

External Static Pressure in. w.c.	Air Volume / Watts at Various Blower Speeds									
	High		Medium-High		Medium		Medium-Low		Low	
	cfm	Watts	cfm	Watts	cfm	Watts	cfm	Watts	cfm	Watts
0.00	1345	340	1255	245	1150	185	895	105	845	95
0.10	1305	345	1225	250	1105	200	855	110	810	95
0.20	1290	360	1190	260	1080	205	825	120	780	105
0.30	1275	370	1150	270	1045	215	785	125	720	110
0.40	1220	385	1120	280	1015	220	735	135	690	120
0.50	1215	390	1090	290	980	230	705	140	635	125
0.60	1190	395	1060	300	950	240	650	150	600	135
0.70	N/A	N/A	1015	300	900	250	620	155	555	140
0.80	N/A	N/A	1000	310	870	260	580	160	520	145

A95UH1E / 95G1UHE 070*B12 PERFORMANCE (Less Filter)

External Static Pressure in. w.c.	Air Volume / Watts at Various Blower Speeds									
	High		Medium-High		Medium		Medium-Low		Low	
	cfm	Watts	cfm	Watts	cfm	Watts	cfm	Watts	cfm	Watts
0.00	1380	315	1305	250	1190	200	965	105	920	100
0.10	1360	325	1270	255	1180	205	915	115	865	100
0.20	1310	335	1250	265	1130	215	880	120	815	110
0.30	1275	340	1205	275	1100	225	835	125	775	115
0.40	1250	355	1175	280	1065	230	795	135	730	125
0.50	1215	370	1145	295	1045	240	745	145	670	130
0.60	1200	380	1100	310	995	245	705	150	640	140
0.70	1145	380	1070	310	960	255	670	160	585	145
0.80	N/A	N/A	1035	320	925	265	610	165	550	155

A95UH1E / 95G1UHE 090*C16 PERFORMANCE (Less Filter)

External Static Pressure in. w.c.	Air Volume / Watts at Various Blower Speeds									
	High		Medium-High		Medium		Medium-Low		Low	
	cfm	Watts	cfm	Watts	cfm	Watts	cfm	Watts	cfm	Watts
0.00	1740	370	1505	250	1370	195	1285	160	1135	125
0.10	1695	390	1470	265	1325	205	1240	170	1090	135
0.20	1660	405	1435	280	1290	220	1195	185	1045	145
0.30	1615	415	1390	295	1240	235	1140	200	995	160
0.40	1590	425	1350	305	1200	245	1110	210	945	165
0.50	1560	440	1310	320	1155	260	1055	225	895	175
0.60	1525	455	1255	335	1105	270	1005	230	855	190
0.70	1475	470	1220	340	1065	285	960	245	805	200
0.80	N/A	N/A	1170	355	1010	295	920	255	760	210

NOTES: All air is measured external to unit without filter (filter not furnished - field provided)

Blower Data

A95UH1E & 95G1UHE 030* B08 PERFORMANCE (Less Filter)

External Static Pressure in. w.g.	Air Volume / Watts at Various Blower Speeds									
	High		Medium-High		Medium		Medium-Low		Low	
	cfm	Watts	cfm	Watts	cfm	Watts	cfm	Watts	cfm	Watts
0.00	1025	122	935	97	855	76	820	76	765	69
0.10	985	129	910	104	820	82	775	72	700	63
0.20	955	139	875	114	770	87	640	62	575	52
0.30	915	145	830	120	730	96	575	67	375	40
0.40	875	155	790	130	680	101	530	74	330	47
0.50	830	161	750	136	635	110	470	79	260	51
0.60	800	172	700	146	580	115	420	82	210	47
0.70	765	181	650	150	550	124	385	90	180	51
0.80	715	187	615	159	500	127	325	94	135	52

Blower Data A95UH1E & 95G1UHE

External Static Pressure in. w.c.	Air Volume / Watts at Different Blower Speeds																			
	Bottom Return Air, Side Return Air with Optional Return Air Base, Return Air from Both Sides or Return Air from Bottom and One Side.										Single Side Return Air - Air volumes in bold require field fabricated transition to accommodate 20 x 25 x 1 in. air filter in order to maintain proper air velocity.									
	High		Medium-High		Medium		Medium-Low		Low		High		Medium-High		Medium		Medium-Low		Low	
	cfm	Watts	cfm	Watts	cfm	Watts	cfm	Watts	cfm	Watts	cfm	Watts	cfm	Watts	cfm	Watts	cfm	Watts	cfm	Watts
0.00	2220	645	1940	435	1765	335	1635	280	1435	200	2185	655	1915	440	1745	340	1620	275	1430	195
0.10	2170	660	1920	460	1715	350	1595	290	1380	205	2160	660	1880	460	1705	345	1570	285	1380	205
0.20	2130	680	1865	475	1670	370	1560	305	1345	220	2115	680	1835	470	1670	365	1535	305	1325	220
0.30	2095	700	1835	490	1640	390	1525	325	1285	230	2060	705	1795	495	1630	380	1505	320	1285	230
0.40	2065	720	1785	510	1600	405	1465	335	1250	245	2050	720	1760	510	1570	400	1455	330	1235	245
0.50	2030	740	1755	525	1560	415	1425	355	1215	260	2000	740	1720	530	1535	415	1410	345	1195	260
0.60	1995	760	1705	550	1525	435	1380	370	1150	270	1950	760	1685	550	1505	435	1380	365	1145	275
0.70	1955	770	1660	560	1475	450	1350	375	1100	290	1935	775	1650	555	1455	450	1325	375	1100	285
0.80	1930	790	1635	575	1445	460	1300	395	1050	305	1890	790	1610	575	1425	460	1285	390	1050	295

A95UH1E / 95G1UHE 135*D20 PERFORMANCE (Less Filter)

External Static Pressure in. w.c.	Air Volume / Watts at Different Blower Speeds																			
	Bottom Return Air, Side Return Air with Optional Return Air Base, Return Air from Both Sides or Return Air from Bottom and One Side.										Single Side Return Air - Air volumes in bold require field fabricated transition to accommodate 20 x 25 x 1 in. air filter in order to maintain proper air velocity.									
	High		Medium-High		Medium		Medium-Low		Low		High		Medium-High		Medium		Medium-Low		Low	
	cfm	Watts	cfm	Watts	cfm	Watts	cfm	Watts	cfm	Watts	cfm	Watts	cfm	Watts	cfm	Watts	cfm	Watts	cfm	Watts
0.00	2405	940	2235	735	2070	545	1830	390	1620	280	2395	925	2235	710	2020	550	1800	380	1610	275
0.10	2365	960	2210	745	2020	565	1770	400	1585	295	2360	935	2175	735	2005	555	1760	395	1550	295
0.20	2330	975	2180	770	1950	580	1745	420	1535	315	2360	955	2160	760	1955	565	1725	415	1510	300
0.30	2295	1000	2120	785	1925	595	1690	435	1480	325	2290	990	2195	775	1890	590	1700	435	1420	325
0.40	2275	1015	2075	805	1885	615	1640	460	1445	340	2255	995	2060	795	1850	615	1635	445	1390	340
0.50	2225	1025	2035	815	1845	630	1605	475	1395	360	2230	1010	2040	815	1845	625	1590	470	1375	360
0.60	2185	1010	2020	835	1815	645	1565	485	1330	365	2170	1025	2000	820	1795	640	1580	485	1335	370
0.70	n/a	n/a	1940	850	1736	665	1520	500	1310	385	n/a	n/a	1935	845	1725	660	1520	500	1295	385
0.80	n/a	n/a	1890	860	1715	680	1465	510	1285	400	n/a	n/a	1880	855	1705	680	1470	510	1260	405

NOTES: All air is measured external to unit without filter (filter not furnished - field provided)

Service



ELECTRICAL SHOCK, FIRE, OR EXPLOSION HAZARD.

Failure to follow safety warnings exactly could result in dangerous operation, serious injury, death or property damage.

Improper servicing could result in dangerous operation, serious injury, death, or property damage.

Before servicing, disconnect all electrical power to furnace.

When servicing controls, label all wires prior to disconnecting. Take care to reconnect wires correctly. Verify proper operation after servicing.

At the beginning of each heating season, system should be checked as follows by a qualified service technician:

Blower

Check the blower wheel for debris and clean if necessary. The blower motors are prelubricated for extended bearing life. No further lubrication is needed.



The blower access panel must be securely in place when the blower and burners are operating. Gas fumes, which could contain carbon monoxide, can be drawn into living space resulting in personal injury or death.

Filters

All air filters are installed external to the unit. Filters should be inspected monthly. Clean or replace the filters when necessary to ensure proper furnace operation. Table 1 lists recommended filter sizes.

Exhaust and air intake pipes

Check the exhaust and air intake pipes and all connections for tightness and to make sure there is no blockage.

NOTE: *After any heavy snow, ice or frozen fog event the furnace vent pipes may become restricted. Always check the vent system and remove any snow or ice that may be obstructing the plastic intake or exhaust pipes.*

Electrical

1. Check all wiring for loose connections.
2. Check for the correct voltage at the furnace (with furnace operating). Correct voltage is 120 VAC \pm 10%
3. Check amp-draw on the blower motor with the blower access panel in place.
Motor Nameplate _____ Actual _____

Winterizing and Condensate Trap Care

1. Turn off power to the furnace.
2. Have a shallow pan ready to empty condensate water.
3. Remove the clean out cap from the condensate trap and empty water. Inspect the trap then reinstall the clean out cap.

Cleaning Heat Exchanger

If cleaning the heat exchanger becomes necessary, follow the below procedures and refer to Figure 1 when disassembling unit. Use papers or protective covering in front of furnace while removing heat exchanger assembly.

1. Turn off electrical and gas supplies to the furnace.
2. Remove the burner access panel.
3. Mark all gas valve wires and disconnect them from valve.
4. Remove gas supply line connected to gas valve.
5. Remove sensor wire from flame sensor. Disconnect 2-pin plug from the ignitor.
6. Disconnect wires from flame rollout switches.
7. Remove four burner assembly screws at the vestibule panel and remove gas valve /manifold and burner box as a single unit.
8. If necessary, clean burners at this time. Follow procedures outlined in Burner Cleaning section.
9. Remove the clean-out cap on trap and drain. Replace cap.
10. Disconnect condensate drain line from the condensate trap. Remove condensate trap (it may be necessary to cut drain pipe). Remove the 1/2" NPT fitting from the cold end header box. Disconnect drain tubes from cold end header collector box.
11. Disconnect condensate drain tubes from flue collar. Remove screws that secures flue collar in place. Remove flue collar. It may be necessary to cut the exiting exhaust pipe for removal of the fitting.
12. Loosen two clamps from flexible no-hub exhaust collar.
13. Disconnect the 2-pin plug from the combustion air inducer. Remove screws which secure combustion air inducer to collector box. Remove combustion air inducer assembly. Remove ground wire.
14. Mark and disconnect all combustion air pressure tubing from cold end header collector box.
15. Mark and remove wires from pressure switch. Remove pressure switch. Keep tubing attached to pressure switch.

16. Remove electrical junction box from the side of the furnace.
17. Remove blower access panel.
18. Mark and disconnect any remaining wiring to heating compartment components. Disengage strain relief bushing and pull wiring and bushing through the hole in the blower deck.
19. Remove the primary limit from the vestibule panel.
20. Remove top cap screws to allow top cap to be tilted upward to allow clearance for removing heat exchanger.
21. Remove two screws from the front cabinet flange at the blower deck. Spread cabinet sides slightly to allow clearance for removal of heat exchanger.
22. Remove screws along vestibule sides and bottom which secure vestibule panel and heat exchanger assembly to cabinet. Remove two screws from blower rails which secure bottom heat exchanger flange. Remove heat exchanger from furnace cabinet.
23. Back wash heat exchanger with soapy water solution or steam. If steam is used it must be below 275°F (135°C).
24. Thoroughly rinse and drain the heat exchanger. Soap solutions can be corrosive. Take care to rinse entire assembly.
25. Reinstall heat exchanger into cabinet making sure that the rear baffle of the heat exchanger assembly is nested under the support located at the rear of the cabinet. Remove the indoor blower to view this area through the blower opening.
26. Re-secure the supporting screws along the vestibule sides.
27. Reinstall blower assembly and reinstall two screws through rails.
28. Reinstall cabinet screws on front flange at blower deck.
29. Reinstall screws securing top cap.
30. Reinstall the primary limit on the vestibule panel.
31. Route heating component wiring through hole in blower deck and reinsert strain relief bushing.
32. Reinstall pressure switch and reconnect pressure switch wiring.
33. Carefully connect combustion air pressure switch hosing from pressure switch to proper stubs on cold end header collector box.
34. Reinstall 1/2" NPT (if removed) in the cold end header box. Reconnect drain tubing to collector box.
35. Reinstall condensate trap pipe. Reconnect condensate drain line to the condensate trap.
36. Reinstall electrical junction box.
37. Reinstall the combustion air inducer and flexible no hub connector. Reconnect the 2 pin plug to the wire harness.
38. Reconnect drain tubes between flue collar and cold end header box.
39. Secure burner assembly to vestibule panel using four existing screws. Burners are self aligning to center of clam shells.
40. Reconnect gas supply line to gas valve.
41. Reconnect flame rollout switch wires.
42. Reconnect sensor wire and reconnect 2 pin plug from ignitor.
43. Reconnect wires to gas valve.
44. Replace the blower compartment access panel.
45. Refer to instruction on verifying gas and electrical connections when reestablishing supplies.
46. Follow lighting instructions to light and operate furnace for 5 minutes to ensure that heat exchanger is clean and dry and that furnace is operating properly.
47. Replace heating compartment access panel.

Cleaning the Burner Assembly

1. Turn off gas and electrical power to the furnace. Remove heating compartment access panel.
2. Disconnect the gas supply line from the gas valve.
3. Disconnect and label wires from gas valve.
4. Disconnect ignitor wiring at 2 circuit plug.
5. Disconnect and label wires from rollout switch.
6. Disconnect and label flame sensor wire.
7. Disconnect and label ground wire from burner/manifold assembly.
8. Remove four screws that secures burner/manifold assembly to vestibule. Remove the assembly and make note not to allow ignitor plate to dislodge from the assembly.
9. Gently clean the face of the burners using the soft brush attachment on a vacuum cleaner. Visually inspect the inside of the burners and crossovers for any blockage caused by foreign matter. Remove any blockage
10. Reinstall the burner/manifold assembly using the existing four screws. **Burners are self aligning to center of clam shells.**
11. Reconnect ground wire.
12. Reconnect flame sensor wire.
13. Reconnect rollout switch wires.
14. Reconnect ignitor wires.
15. Reconnect gas valve wires.
16. Reconnect gas supply line to gas valve.
17. Refer to instructions on verifying gas and electrical connections when re-establishing supplies.
18. Follow instructions to place furnace in operation. Run furnace 5 minutes to ensure burners are clean and operating correctly.
19. Replace heating compartment access panel.

Planned Service

A service technician should check the following items during an annual inspection. Power to the unit must be shut off for safety.

Fresh air grilles and louvers (on the unit and in the room where the furnace is installed) - Must be open and unobstructed to provide combustion air.

Burners - Must be inspected for rust, dirt, or signs of water.

Vent pipe - Must be inspected for signs of water, cracked, damaged or sagging pipe, or disconnected joints.

Unit appearance - Must be inspected for rust, dirt, signs of water, burnt or damaged wires, or components.

Blower access door - Must be properly in place and provide a seal between the return air and the room where the furnace is installed.

Return air duct - Must be properly attached and provide an air seal to the unit.

Operating performance - Unit must be observed during operation to monitor proper performance of the unit and the vent system.

Combustion gases - Flue products should be analyzed and compared to the unit specifications.

Problems detected during the inspection may make it necessary to temporarily shut down the furnace until the items can be repaired or replaced.

Instruct the homeowners to pay attention to their furnace. Situations can arise between annual furnace inspections that may result in unsafe operation. For instance, items innocently stored next to the furnace may obstruct the combustion air supply. This could cause incomplete combustion and the production of carbon monoxide gas.

Diagnostic Codes

RED LED Flash Code	Diagnostic Codes / Status of Furnace
Off	No power to control or board fault detected
Heartbeat ¹	Control powered - displayed during all modes of operation if no errors are detected
1 Flash	Reverse Line Voltage Polarity
2 Flashes	Improper Earth Ground
3 Flashes	Burner failed to light, or lost flame during heat demand
4 Flashes	Low Flame Signal - check flame sensor
5 Flashes	Watchguard - burner failed to light, exceeded maximum number of retries or recycles.
6 Flashes	Not Used
7 Flashes	Primary or Secondary Limit Open or Watchguard Mode - Limit Switch Open Longer than 3 minutes
8 Flashes	Rollout Switch Open
9 Flashes	Pressure Switch failed to close or opened during heat demand
10 Flashes	Watchguard - Pressure Switch opened 5 times during one heat demand
11 Flashes	Pressure switch stuck closed prior to activation of combustion air inducer
12 Flashes	Flame Sensed without gas valve energized
13 Flashes	Low Line Voltage

Repair Parts List

The following repair parts are available through Allied Air dealers. When ordering parts, include the complete furnace model number listed on the CSA nameplate. All service must be performed by a licensed professional installer (or equivalent), service agency, or gas supplier.

Cabinet Parts

- Upper Access Panel
- Blower Access Panel
- Top Cap

Control Panel Parts

- Transformer
- Integrated Control Board
- Door Interlock Switch

Blower Parts

- Blower Wheel
- Motor
- Motor Mounting Frame
- Motor Capacitor
- Blower Housing Cutoff Plate

Heating Parts

- Flame Sensor
- Heat Exchanger Assembly
- Gas Manifold
- Combustion Air Inducer
- Gas Valve
- Main Burner Cluster
- Main Burner Orifices
- Pressure Switch
- Ignitor
- Primary Limit Control
- Flame Rollout Switches

Start-Up & Performance Check List

UNIT SET UP

Furnace:
Model Number _____

Serial Number _____

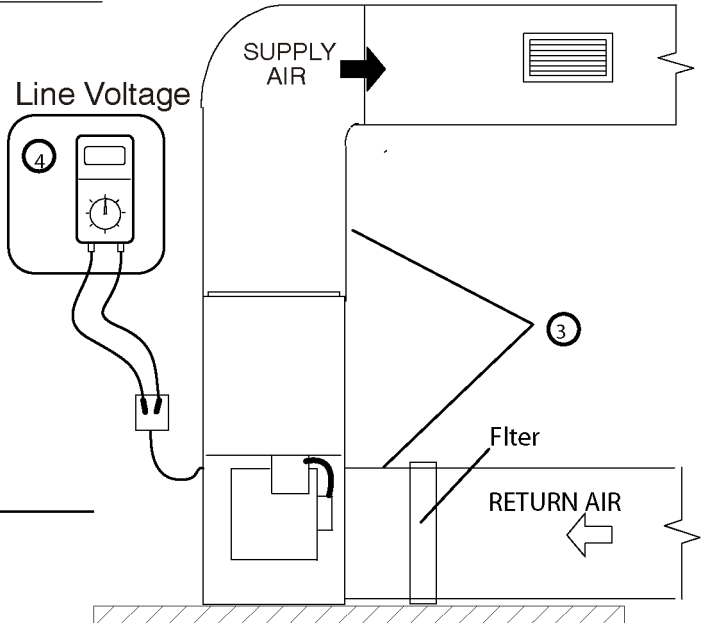
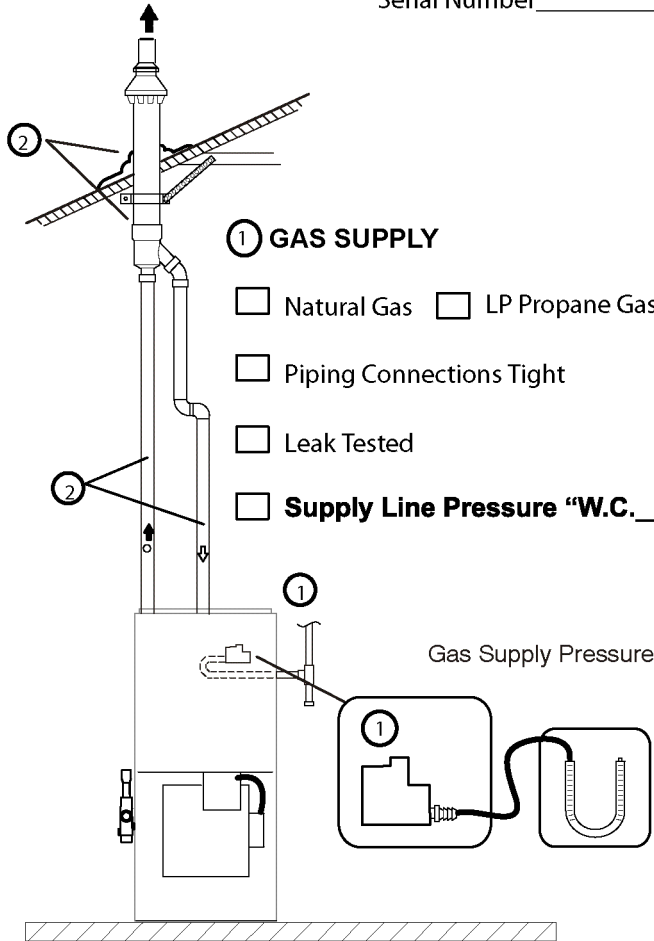

- ③ DUCT SYSTEM**
- SUPPLY AIR DUCT**
- Sealed
 - Insulated (if necessary)

- RETURN DUCT**
- Sealed
 - Filter Installed and Clean
 - Grilles Unobstructed

- ④ VOLTAGE CHECK**
- Supply Voltage _____
- Electrical Connections Tight

- ② INTAKE / EXHAUST PIPE**
- All Joints Primed and Glued
 - Terminations Installed Properly
 - Horizontal Pipes Sloped (if applicable)
 - Condensate Trap Primed / Line Sloped
 - Pipes Supported
 - Heat Cable Installed and Operable (if applicable)

UNIT OPERATION

HEATING MODE

COOLING MODE

- ① GAS MANIFOLD PRESSURE "W.C. _____
- ② COMBUSTION SAMPLE CO ₂% _____ CO PPM _____
- ③ INDOOR BLOWER AMPS _____
- ④ TEMPERATURE RISE
Supply Duct Temperature _____
Return Duct Temperature - _____
Temperature Rise = _____
- ⑤ TOTAL EXTERNAL STATIC
Supply External Static _____
Return External Static + _____
Total External Static = _____

- ③ INDOOR BLOWER AMPS _____
- ④ TEMPERATURE DROP
Return Duct Temperature _____
Supply Duct Temperature - _____
Temperature Drop = _____
- ⑤ TOTAL EXTERNAL STATIC (dry coil)
Supply External Static _____
Return External Static + _____
Total External Static = _____
- ⑧ DRAIN LINE
 Leak Free
- ⑨ THERMOSTAT
 Adjusted and Programmed
 Explained Operation to Owner

- ⑥ CONDENSATE LINE
 Leak Free
- ⑦ VENT PIPE
 Leak Free

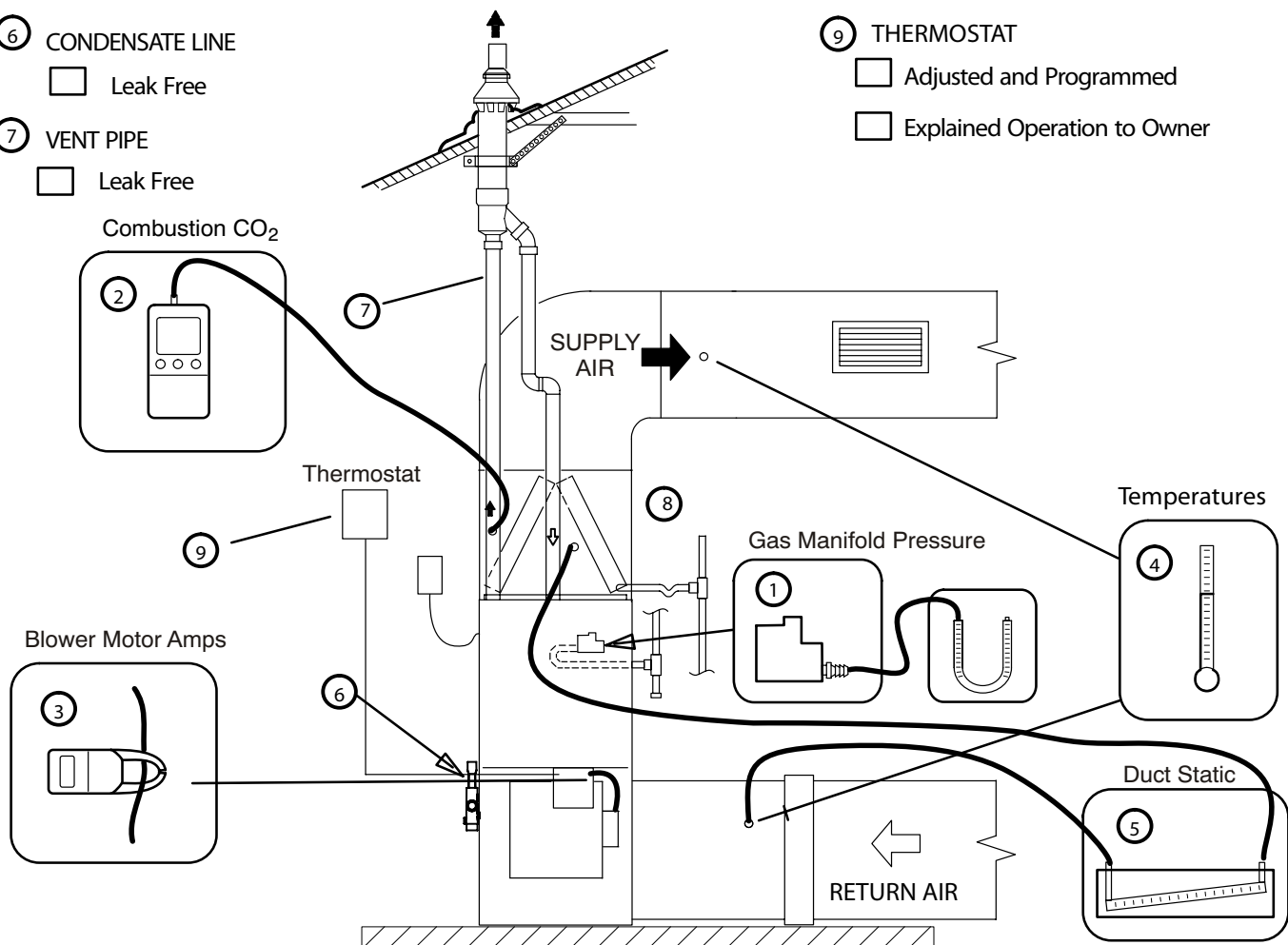

Contractor's: Name _____ Telephone _____ Checklist Completed _____

Job Address _____ Technician's Name _____

REQUIREMENTS for COMMONWEALTH of MASSACHUSETTS

Modifications to NFPA-54, Chapter 10 - Revise NFPA-54 section 10.8.3 to add the following requirements:

For all side wall, horizontally vented, gas-fueled equipment installed in every dwelling, building or structure used in whole or in part for residential purposes, including those owned or operated by the Commonwealth and where the side wall exhaust vent termination is less than seven (7) feet above the finished grade in the area of the venting, including but not limited to decks and porches, the following requirements shall be satisfied:

1. **INSTALLATION OF CARBON MONOXIDE DETECTORS.** At the time of installation of the side wall, horizontally vented, gas-fueled equipment, the installing plumber or gas fitter shall observe that a hard-wired carbon monoxide detector with an alarm and battery backup is installed on the floor level where the gas equipment is to be installed. In addition, the installing plumber or gas fitter shall observe that a battery-operated or hard-wired carbon monoxide detector with an alarm is installed on each additional level of the dwelling, building or structure served by the side wall, horizontally vented, gas-fueled equipment. It shall be the responsibility of the property owner to secure the services of qualified licensed professionals for the installation of hard-wired carbon monoxide detectors.
 - a. In the event that the side wall, horizontally vented, gas-fueled equipment is installed in a crawl space or an attic, the hard-wired carbon monoxide detector with alarm and battery backup may be installed on the next adjacent floor level.
 - b. In the event that the requirements of this subdivision cannot be met at the time of completion of installation, the owner shall have a period of thirty (30) days to comply with the above requirements; provided, however, that during said thirty (30) day period, a battery-operated carbon monoxide detector with an alarm shall be installed.
2. **APPROVED CARBON MONOXIDE DETECTORS.** Each carbon monoxide detector as required in accordance with the above provisions shall comply with NFPA 720 and be ANSI/UL 2034 listed and IAS certified.
3. **SIGNAGE.** A metal or plastic identification plate shall be permanently mounted to the exterior of the building at a minimum height of eight (8) feet above grade directly in line with the exhaust vent terminal for the horizontally vented, gas-fueled heating appliance or equipment. The sign shall read, in print size no less than one-half (1/2) inch in size, **“GAS VENT DIRECTLY BELOW. KEEP CLEAR OF ALL OBSTRUCTIONS.”**

4. **INSPECTION.** The state or local gas inspector of the side wall, horizontally vented, gas-fueled equipment shall not approve the installation unless, upon inspection, the inspector observes carbon monoxide detectors and signage installed in accordance with the provisions of 248 CMR 5.08(2)(a) 1 through 4.

EXEMPTIONS: The following equipment is exempt from 24 CMR 5.08(2)(a) 1 through 4:

1. The equipment listed in Chapter 10 entitled “Equipment Not Required to Be Vented” in the most current edition of NFPA 54 as adopted by the Board; and
2. Product Approved side wall, horizontally vented, gas-fueled equipment installed in a room or structure separate from the dwelling, building or structure used in whole or in part for residential purposes.

MANUFACTURER REQUIREMENTS - GAS EQUIPMENT VENTING SYSTEM PROVIDED.

When the manufacturer of Product Approved side wall, horizontally vented, gas-fueled equipment provides a venting system design or venting system components with the equipment, the instructions provided by the manufacturer for installation of the equipment and the venting system shall include:

1. Detailed instructions for the installation of the venting system design or the venting system components; and
2. A complete parts list for the venting system design or venting system.

MANUFACTURER REQUIREMENTS - GAS EQUIPMENT VENTING SYSTEM NOT PROVIDED.

When the manufacturer of Product Approved sidewall, horizontally vented, gas-fueled equipment does not provide the parts for venting the flue gases, but identifies “special venting systems,” the following requirements shall be satisfied by the manufacturer:

1. The referenced “special venting system” instructions shall be included with the appliance or equipment installation instructions; and
2. The “special venting systems” shall be Product Approved by the Board, and the instructions for that system shall include a parts list and detailed installation instructions.

A copy of all installation instructions for all Product Approved side wall, horizontally vented, gas-fueled equipment, all venting instructions, all parts lists for venting instructions, and/or all venting design instructions shall remain with the appliance or equipment at the completion of the installation.