

BDS SERIES

Oil-Fired Hot Water BOILERS

INSTALLATION INSTRUCTIONS

These instructions must be affixed on or adjacent to the boiler.

MODELS

- * BDS-080
- * BDS-092
- BDS-119
- * BDS-111
- BDS-150
- BDS-178
- * BDS-147
- BDS-209
- BDS-236

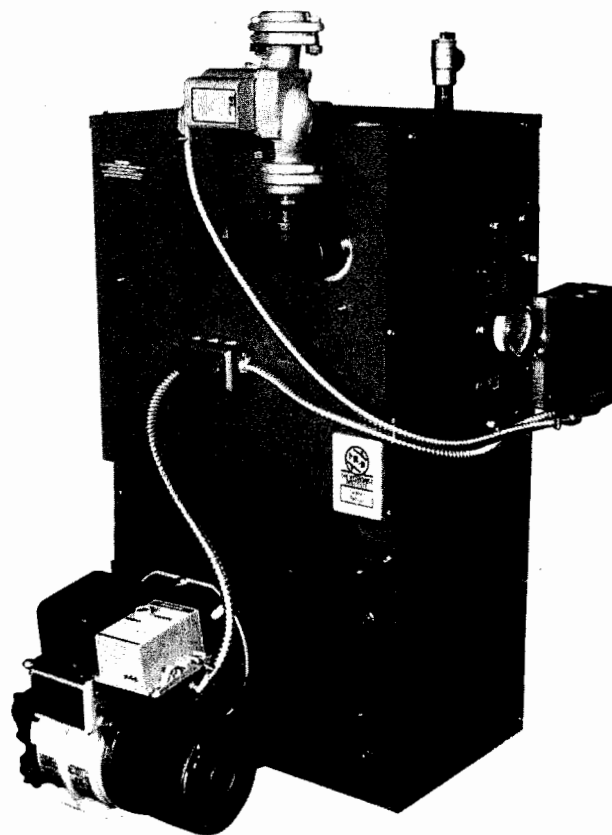

* As an ENERGY STAR Partner, Crown Boiler Company has determined that this product meets the ENERGY STAR guidelines for energy efficiency.

WARNING: Improper installation, adjustment, alteration, service or maintenance can cause property damage, injury, or loss of life. For assistance or additional information consult a qualified installer or service agency.



CROWN BOILER CO

P.O. Box 14818 3633 "I" Street Philadelphia, PA 19134

WWW.CROWNBOILER.com

BOILER RATINGS AND CAPACITIES

Fig. 1

DIMENSIONS (In Inches)

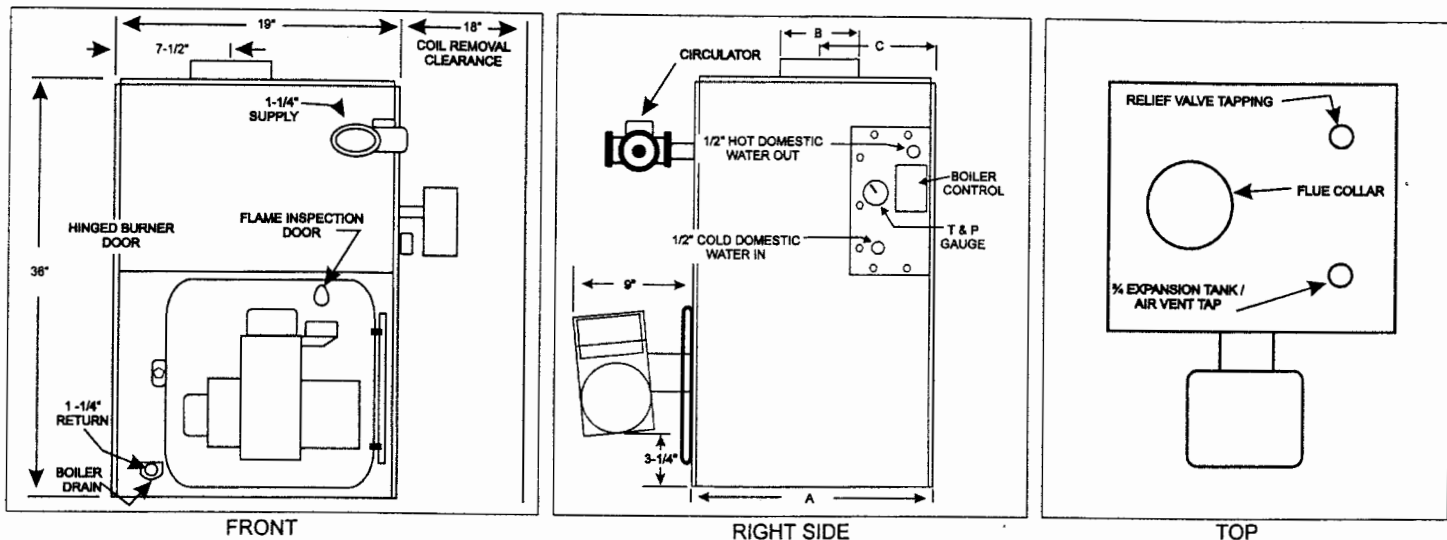

SPECIFICATIONS

MODEL	NO. OF SECS.	D.O.E. HEATING CAPACITY BTU/HR	IBR NET WATER RATING BTU/HR 1	NET RATING WATER SQ. FT. 2	BURNER CAPACITY GPH	TANKLESS HEATER GPM	CHIMNEY SIZE IN. X IN. X FT.	DIMENSIONS IN INCHES			APPROX. SHIPPING WEIGHT PACKAGED	DOE ANNUAL EFFICIENCY (AFUE)
								A	B	C		
BDS-80	3	80,000	70,000	467	.65	2.00	8 x 8 x 15	14 - 1/2	6	8	470	86.3
BDS-92	3	92,000	80,000	533	.75	2.50	8 x 8 x 15	14 - 1/2	6	8	470	85.2
BDS-119	3	119,000	103,000	687	1.00	3.00	8 x 8 x 15	14 - 1/2	6	8	470	83.4
BDS-111	4	111,000	97,000	647	.90	2.75	8 x 8 x 15	17 - 3/4	6	9 - 5/8	545	86.0
BDS-150	4	150,000	133,000	867	1.25	3.25	8 x 8 x 15	17 - 3/4	6	9 - 5/8	545	83.9
BDS-178	4	178,000	155,000	1033	1.50	3.50	8 x 8 x 15	17 - 3/4	6	9 - 5/8	545	82.4
BDS-147	5	147,000	128,000	853	1.20	3.15	8 x 8 x 15	21	6	11 - 1/2	630	86.5
BDS-209	5	209,000	182,000	1213	1.75	4.00	8 x 8 x 20	21	6	11 - 1/2	630	83.6
BDS-236	5	236,000	205,000	1367	2.00	4.50	8 x 8 x 20	21	6	11 - 1/2	630	82.0

1. Net Ratings shown are based on a piping and a pick-up allowance of 1.15.
2. Net Ratings in sq. ft. are based on 170 deg. Average water temperature in radiators. For higher water temperatures, select boiler on basis of net ratings in BTU/HR. Consult the manufacturer for installation having unusual piping and pick-up requirements such as intermittent system operation, extensive piping systems, etc.

3. Firing rate in GPH based on oil having a heat value of 140,000 BTU/GAL.
4. Tankless heater ratings based on Average Temperature Rise of 90 deg. With 200 deg. Boiler water temperature and 40 deg. Heater inlet temperature. (Intermittent draw).

* Specifications and dimensions are subject to change without notice

BOILER NOT FOR INSTALLATION ON COMBUSTIBLE FLOORS

Selection of boiler size should be based upon:

1. "Net I=B=R Rating MBH" being equal to or greater than the calculated heat loss of the building.
2. Sq. Ft. 185 Btuh (@ 190 deg. F.) Being equal to or greater than radiation already installed in the building.

The Net I=B=R Ratings shown are based on an allowance of 1.15 in accordance with the factors shown on the I=B=R Standard as published by The Hydronics Institute.

These boilers must have a non-combustible base if installed on a combustible floor. Two-inch concrete patio blocks may be used. These boilers are low pressure sectional cast iron boilers constructed and hydrostatically tested for a maximum working pressure of 30 psi in accordance with A.S.M.E. (American Society of Mechanical Engineers) Code IV Standards for cast iron boilers. They are capacity rated in accordance with the code of the I=B=R (Hydronics Institute).

Rules for Safe Installation and Operation

1. Read the owners manual for Safe Operation carefully. Failure to follow the rules for safe operation and the instructions can cause a malfunction of the boiler and result in death, serious bodily injury, and/or property damage.
2. Check your local codes and utility requirements before installation. The installation must be in accordance with their directives. In the absence of any local codes, install in accordance with the latest edition of NFPA 31.
3. Before servicing, allow boiler to cool. Always shut off any electricity and oil to boiler when working on it. This will prevent any electrical shocks or burns.
4. Inspect oil line and connections for leaks.
5. Be certain oil burner nozzle size is required. Overfiring will result in early failure of the boiler sections. This will cause dangerous operation.
6. Never vent this boiler into an enclosed space. Always connect the boiler to a chimney and vent to the outside. Never vent to another room or inside a building.
7. Be sure there is adequate air supply for complete combustion.
8. Follow a regular service and maintenance schedule for efficient and safe operation.
9. Keep boiler area clean and free of combustible material, gasoline and other flammable vapors and liquids.

Before You Start

Check to be sure you have the right size boiler before starting the installation. See rating and capacity table on preceding page. Check the rating plate on the right side of the boiler.

You must see that the boiler is supplied with the proper oil, fresh air for combustion and a suitable electrical supply. Also, the boiler must be connected to a suitable chimney and an adequate piping system. Finally, a thermostat, properly located, is needed for control of the heating system. If you have any doubts as to the various requirements, check with local authorities and obtain professional help where needed. THE FINAL CHECKS AND ADJUSTMENTS starting on page 13 are vital to the proper and safe operation of the heating system. Take the time to be sure they are all done.

The following steps are all necessary for proper installation and safe operation of your boiler.

1. LOCATING THE BOILER
2. OIL SUPPLY AND PIPING
3. FRESH AIR FOR COMBUSTION
4. PIPING CONNECTIONS
5. CHIMNEY & VENT PIPE CONNECTIONS
6. ELECTRICAL WIRING
7. THERMOSTAT LOCATION
8. CHECKING & ADJUSTING

Power ("Side Wall") Venting - Important Note

Two problems arise when power venting any oil appliance:

1. There is sometimes an accelerated rate at which soot builds up on the cad-cell, spinner, etc.
2. There is the potential for severe damage to the side of the structure in the event that the boiler operates at a high smoke level. This can happen for many reasons, some of which are out of the control both the installer and appliance manufacturer.

Crown Boiler Company recommends the use of a chimney to vent our residential oil boilers. If a power venter must be used, it is the responsibility of the installer and power vent manufacturer to "engineer" the power vent system. **CROWN WILL ASSUME NO RESPONSIBILITY FOR DAMAGE TO SIDING, ETC. FROM A POWER VENTED OIL BOILER. THIS APPLIES REGARDLESS OF THE CAUSE OF THE SOOTING.**

Locating the Boiler

If the boiler is to be part of an existing system, it is usually best to put it where the old one was. If you plan to change location, you will need additional materials as well as an adequate base. The following rules apply:

1. The boiler must be level.
2. Use a raised base if floor can become wet or damp.
3. The vent pipe connection should be as short as possible. The center of the chimney opening must be at least 52" above the floor on which the boiler stands.
4. Maintain clearances for fire safety as well as servicing. See fig. 2 for minimum clearances. 18" clearance must be maintained at a side where passage is required for access to another side for cleaning or servicing, inspection or replacement of any parts that normally may require such attention. Boilers must be installed at least 12" from combustible material on all sides. Allow at least 18" front and right side for servicing.
5. FRESH AIR for combustion must be available at the front of the boiler. FRESH AIR for ventilation must be available to the front AND rear of the boiler. If the enclosure is small (like a closet), provide two openings: one 6 in. below ceiling and one 6 in. above floor. If larger (like a utility room) but closed off, provide at least one opening. Openings should preferably be to outside (by duct or grille), but may be into the living area if this is not tightly weather stripped or vented by

an exhaust fan. Area of each opening must equal 150 sq. in. for each GPH of burner firing rate. Air passages must be free of obstructions at all times. Ventilating and combustion air must enter boiler room without restrictions.

6. The floor supporting the boiler must be non-combustible. If it is combustible, place the boiler on 2" concrete patio blocks. The blocks must be under the entire boiler to protect the floor.
7. Be sure installation is in accordance with the requirements of the local authorities having jurisdiction. Compliance with these regulations is required.

FIG. 2 - MINIMUM CLEARANCE DIMENSIONS

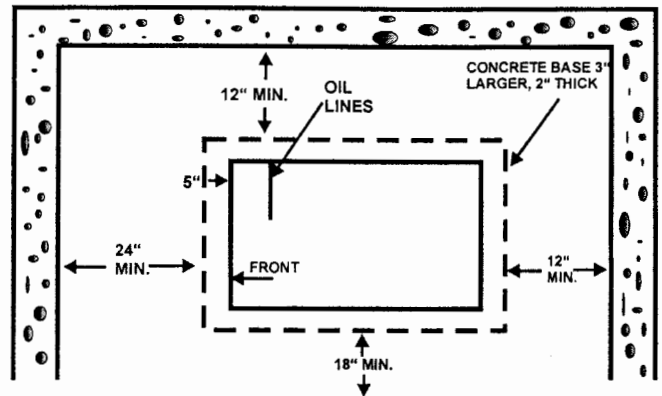

Installation Requirements

FIG. 3

ALWAYS KEEP THE MANUAL FUEL SUPPLY VALVE SHUT OFF, IF THE BURNER IS SHUT DOWN FOR AN EXTENDED PERIOD OF TIME.

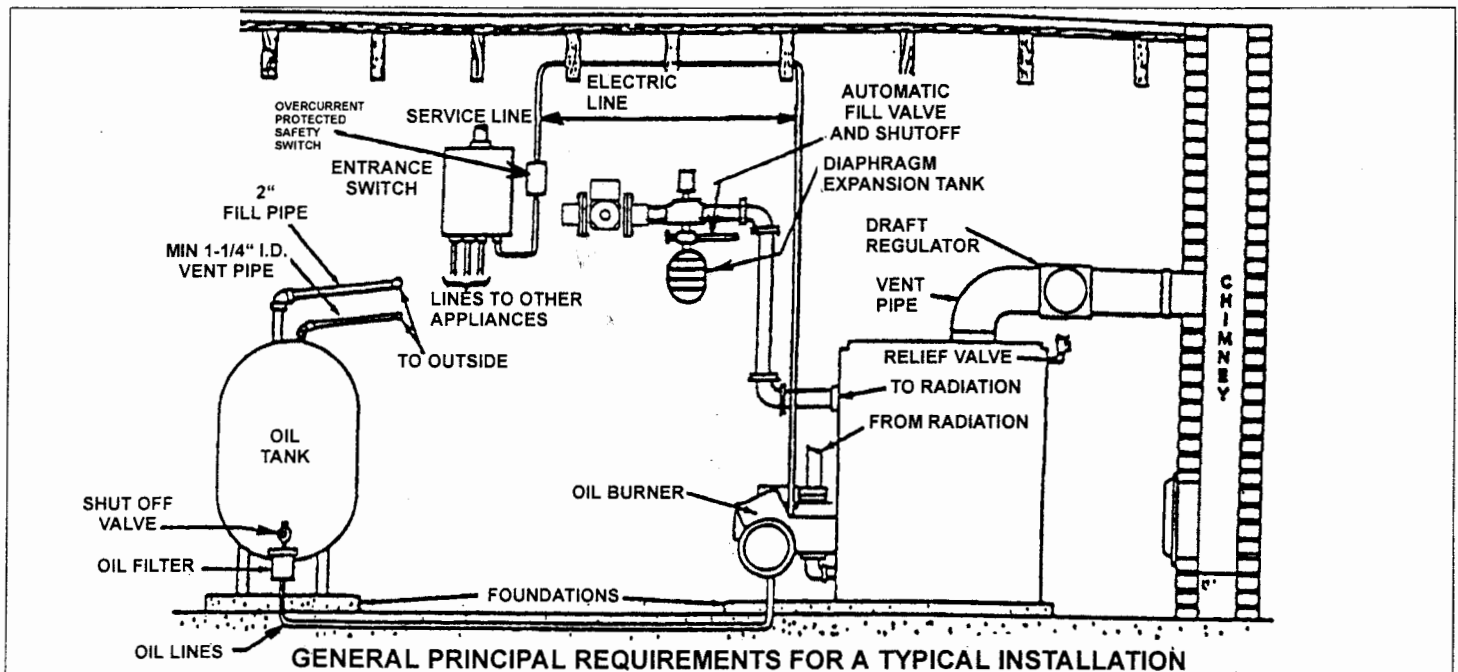

Fresh Air for Combustion

WARNING

Be sure to provide enough fresh air for combustion.

You must provide for enough fresh air to assure proper combustion. The fire in the boiler uses oxygen. It must have a continuous supply. The air in a house contains only enough oxygen to supply the burner for a short time. Outside air must enter the house to replace that used by the burner. Study following examples 1 and 2 to determine your fresh air requirements.

EXAMPLE 1: Boiler located in unconfined Space

- A. If your boiler is in an open area (unpartitioned basement) in a conventional house, the air that leaks through the cracks around doors and windows will usually be adequate to provide air for combustion.
- B. When the boiler is in a building of tight construction where the windows are weather-stripped, air for combustion and ventilation must be obtained from outdoors by means of an air intake. See example 2, paragraph B.

EXAMPLE 2: Boiler Located in Confined Space

- A. When the boiler is in a closet or utility room, install two open grilles in a wall or door opening to the rest of the house. One grille is to supply combustion air. Locate it near the floor. The other grille is for ventilation. Locate it near the ceiling. Each grille must have a FREE (actual open) area of not less than one square inch for each 1,000 Btu/Hr. of the total input rating of all the appliances in the confined space.

Example: Your boiler is rated at 100,000 Btu per hour. The water heater is rated at 30,000 Btu per hour. The total is 130 square inches of FREE opening. Metal grilles have about 60% FREE area. To find the louvered area needed, multiply the FREE required by 1.7 ($130 \times 1.7 = 221.0$ sq. in. louvered area.) In this example two grilles, each having an 8" x 30" (240 sq. in.) Louvered area would be used. Fig. 4 shows the grille locations.

- B. If the house is of tight construction with weather-stripped windows, not enough outside air will enter for safe combustion. Install a duct or pipe from a point near the burner, to a ventilated attic or crawl space or the the outside where fresh air is freely available. The duct should have a net free area of 1 square inch for each 5,000 Btu per hour input of all appliances. Screen the openings to keep animals or birds from entering. Refer to Fig. 6. Fig. 5 shows the Btu per hour capacities of ducts with several screening methods.

WARNING

Enough air insures proper combustion and assures that no hazard will develop due to the lack of oxygen.

FIG. 4 - AIR OPENINGS FOR CLOSET OR UTILITY ROOM INSTALLATIONS

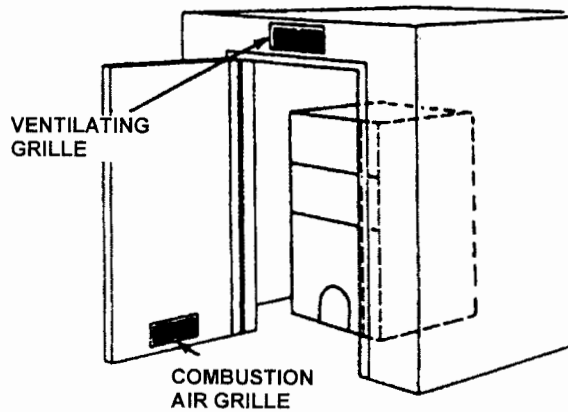

FIG. 5 - FRESH AIR DUCT CAPACITIES

Fresh Air Duct Capacities for Ducts Supplying Fresh Air to boiler in tightly constructed houses. British Thermal Units per hour Input (Btuh)*

FRESH AIR DUCT SIZE	1/4" MESH SCREEN Btuh	WOOD LOUVERS Btuh	METAL LOUVERS Btuh
3-1/2" x 12"	144,000	36,000	108,000
8" x 8"	256,000	64,000	192,000
8" x 12"	384,000	96,000	288,000
8" x 16"	512,000	128,000	384,000

* Based on opening covered by 1/4" mesh screen, wood louvers, or metal louvers.

FIG. 6 FRESH AIR DUCT FOR TIGHTLY SEALED HOUSE

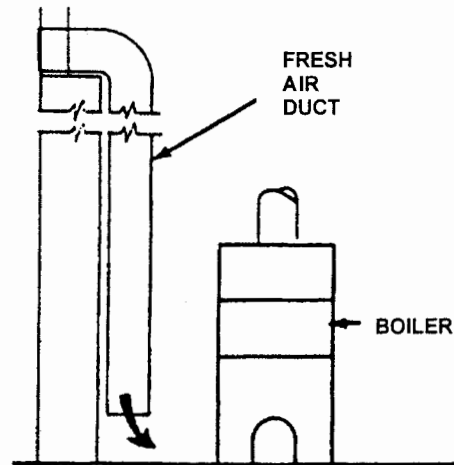

Tankless Heater Coil Installation

Tankless Heater Coil is optional.

The use of this coil eliminates the need for a hot water storage tank. Instantaneous heating of water in the coil will provide a flow of hot water for domestic use - if proper water supply line controls are used.

IMPORTANT

Do not use a tankless coil if your water is excessively hard with lime or other deposits which will accumulate inside the coil.

1. Unpack coil, gasket. Be sure all the parts are in good order.
2. Drain boiler and system.
3. Remove jacket cover panel.
4. Remove screws holding cover plate and gasket. Remove cover plate and gasket and discard.
5. Place gasket over the coil and up against inside face plate. Insert coil into boiler opening. be sure arrow stamped in the face plate points upward and the word "TOP" (if shown) is at the top. Replace the ten 3/8" x 3/4" hex head cap screws. Tighten evenly and snug. Do not exert extreme pressure and snap the bolts.

6. Re-install the jacket panel.
7. Set limits as per instruction sheet with control.
8. Fill boiler and system.

FIG. 7

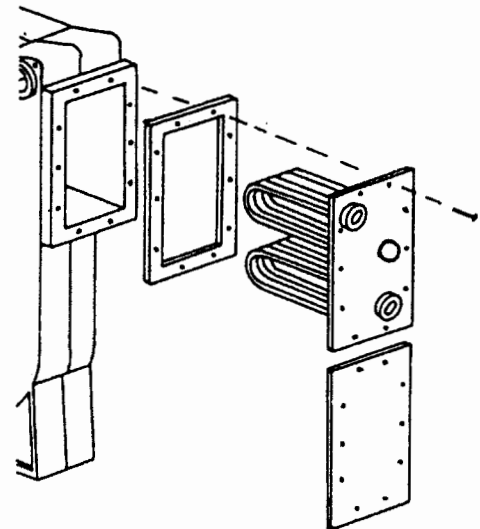

Installation System Piping

1. Place boiler in the selected location (as near flue as possible) (Refer to Figure 3). Your boiler is shipped assembled, you need only to install the relief valve provided.
2. Install Relief Valve in rear section on 3/4" x 5" nipple. Connect a drain line of the same pipe size (3/4") to carry any water away to a drain or 6" above ground.
3. Install Drain Valve on the lower left side of the boiler as marked.

Connect Supply and Return Lines to boiler. The connections may require certain additional fittings and parts, as shown on diagram (Figs. 8 & 10).

If you are installing an entire new heating system, first install all of your radiation units (panels, radiators or cabinets) and the Supply and Return Mains - then make the connections at the boiler.

In connecting the cold water supply to the reducing valve, make sure that a clean water supply is available. When the water supply is from a well or pump, a sand strainer should be installed at the pump.

When boiler is used in connection with refrigeration systems it shall be installed so that the chilled medium is piped in parallel with the heating boiler with appropriate valves to prevent the chilled medium from entering the heating boiler.

FIG. 8

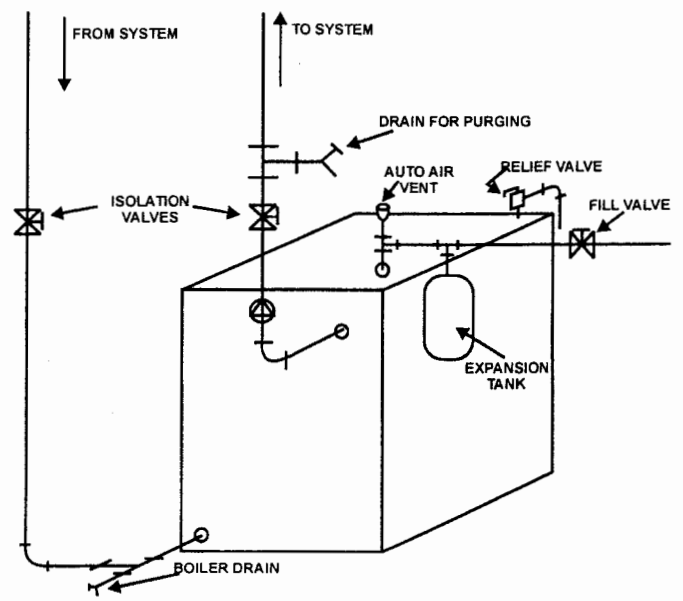

NOTE

- Do not use 1 1/4" tappings on back of boiler.
- 3/4" Tap on back of boiler may be used for an alternative relief valve location. If this is done, mount the relief valve on an elbow so that the relief valve spindle is vertical.

FIGURE 10 - LARGE WATER CONTENT SYSTEMS

Systems such as converted gravity systems, old systems with cast iron radiators, and newer systems that employ outdoor reset control, present a potential problem with low return water temperatures and condensation. The boiler must be protected from condensation in such cases by using a by-pass.

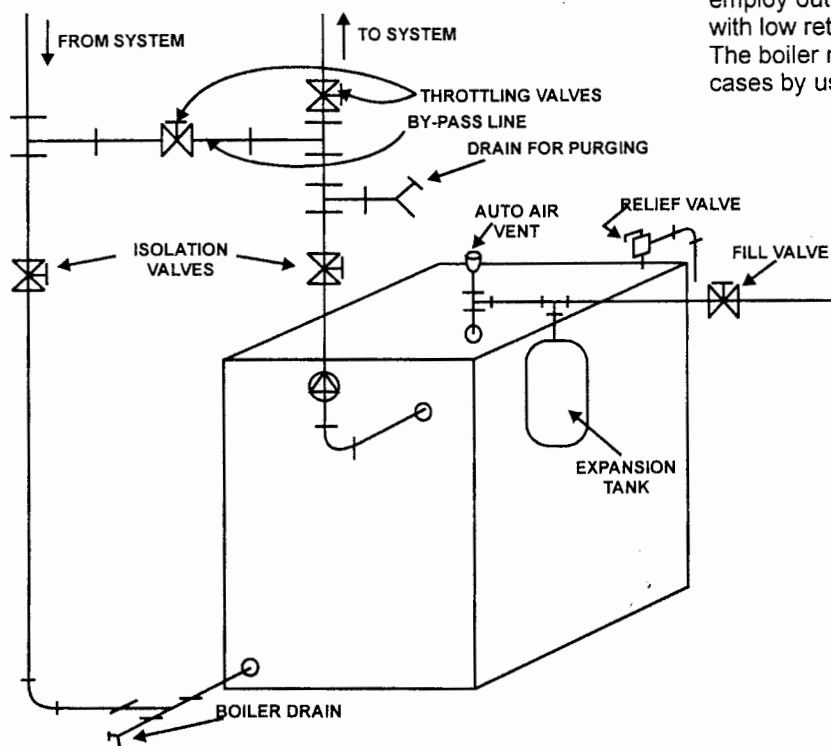

Chimney and Vent Pipe Connection

CHECK YOUR CHIMNEY

This is a very important part of your heating system. No boiler, however efficient its design, can perform satisfactory if the chimney that serves it is inadequate. Check your chimney to make certain that it is the right size, properly constructed and in sound condition.

If yours is an old masonry chimney, a new steel liner or a new prefabricated chimney may be the best solution.

RECOMMENDED MINIMUM CHIMNEY SIZES

FIRING RATE (gph)	CHIMNEY HEIGHT (ft)	NOMINAL CHIMNEY AREA	ROUND LINER - INSIDE DIAMETER	SQUARE LINER - INSIDE DIMENSIONS
0.60 - 1.30	15	8" x 8"	6"	6-3/4" x 6-3/4"
1.31 - 1.80	15	8" x 8"	7"	6-3/4" x 6-3/4"
1.81 - 2.00	20	8" x 8"	8"	6-3/4" x 6-3/4"

For elevations above 2,000 feet sea level, add 3 feet to the chimney heights.

For additional chimney design and sizing information, consult the ASHRAE 1996 HVAC Systems and Applications Handbook, Chapter 30, Gas Vent and Fireplace Systems, or the National Standard for Chimneys, Fireplaces, Vents and Solid Fuel Burning Appliances, ANSI/NFPA 211.

If your home is located more than 2,000 ft. above sea level, add 3 feet to chimney heights (Refer to Figure 11.)

VENT PIPE AND DRAFT REGULATOR

Your boiler requires 6" dia. vent pipe on all models. You must also use a draft regulator packed with boiler. Properly installed, the regulator will control the draft automatically. It is better to install it in a horizontal section of pipe; But it may be in an angled or vertical section. Just make certain that the "top" is at the top - and that the short pipe section which holds the vane is horizontal. Install it as close as practicable to the boiler.

To install the vent pipe run, start at the boiler with a vertical pipe and then an elbow - then install the draft regulator next, making it horizontal. When the regulator is in place, start at the chimney and work back to the regulator. Join the two sections with a Drawband. The horizontal pipe must slope upward the chimney at least 1/4 inch per foot. It must not leak and must be firmly supported. Join sections with at least two sheet-metal screws. Support every second section with a stovepipe wire.

MINIMUM VENT PIPE CLEARANCE

Wood and other combustible materials must not be closer than 18" from any surface of the vent pipe.

FIG. 11

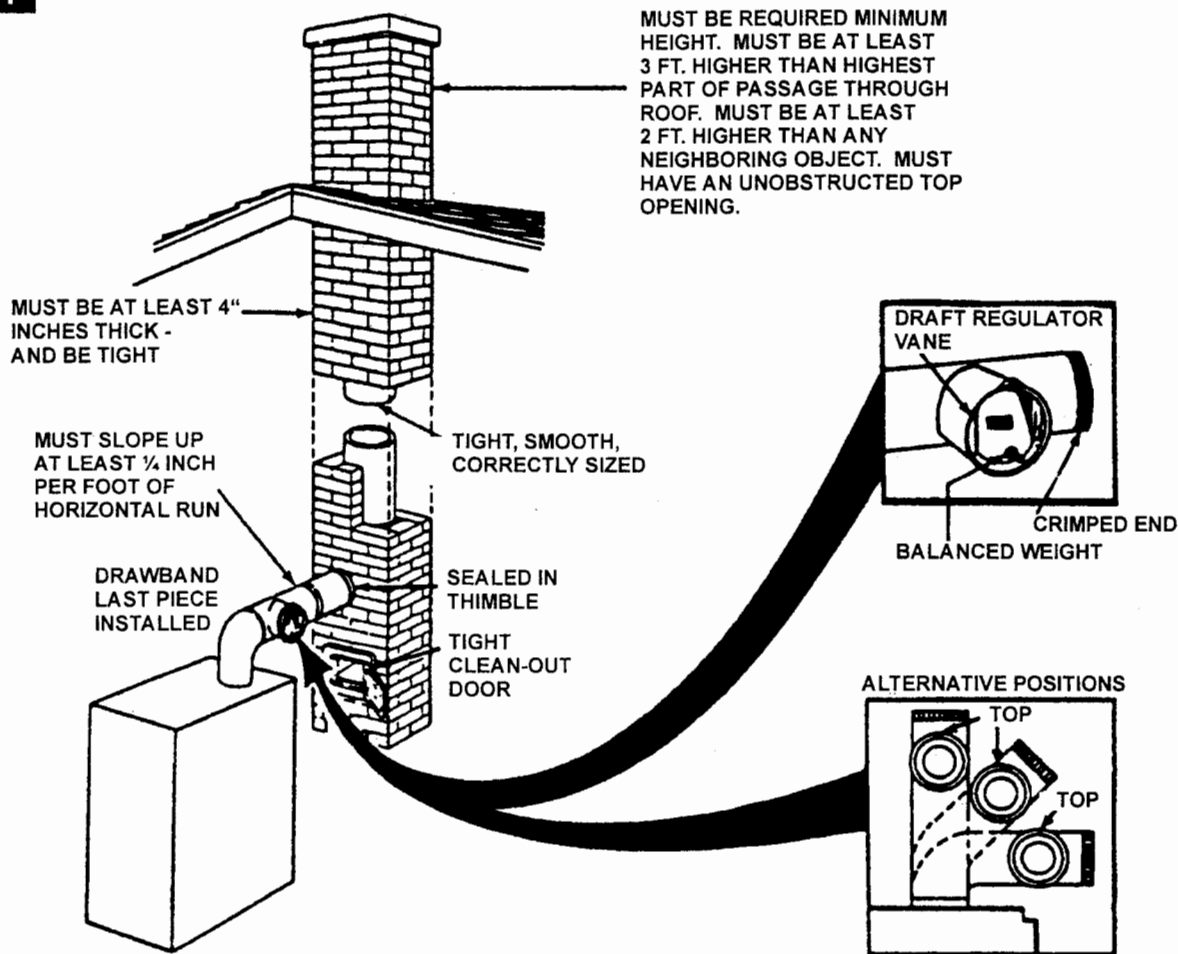

Electrical Wiring

INSTALL YOUR THERMOSTAT (Not Provided)

The 24-volt thermostat location has an important effect on the operation of your boiler system. **BE SURE TO FOLLOW THE INSTRUCTIONS INCLUDED WITH YOUR THERMOSTAT.**

GROUNDING

Permanently ground your boiler according to local codes and the National Electrical Code. Run a 14 gauge or heavier copper wire from the boiler to a grounded connection in the service panel or a properly driven and electrically grounded ground rod.

ELECTRICAL POWER SUPPLY

All electrical work must conform to your local codes as well as the National Electrical Code. If you are not familiar with wiring and codes in general, have a competent electrician do this job. Run a separate circuit from a separate fuse in your electrical service entrance panel. This should be a 15 ampere circuit.

The boiler controls are all wired at the factory. You need only connect a 115 volt electric supply and the thermostat wires to the Honeywell relay Hot Water Control on the front of the boiler.

WARNING

Turn off electric power at fuse box before making any line voltage connections. Follow local electrical codes.

CONNECTING 115 ELECTRIC WIRING TO BOILER

Connect the 115 volt electric supply wires to terminals L1 and L2 on the relay (Fig. 12).

THERMOSTAT CONNECTIONS

The two wires from the thermostat connect to terminals T and T on the relay.

FIG. 12

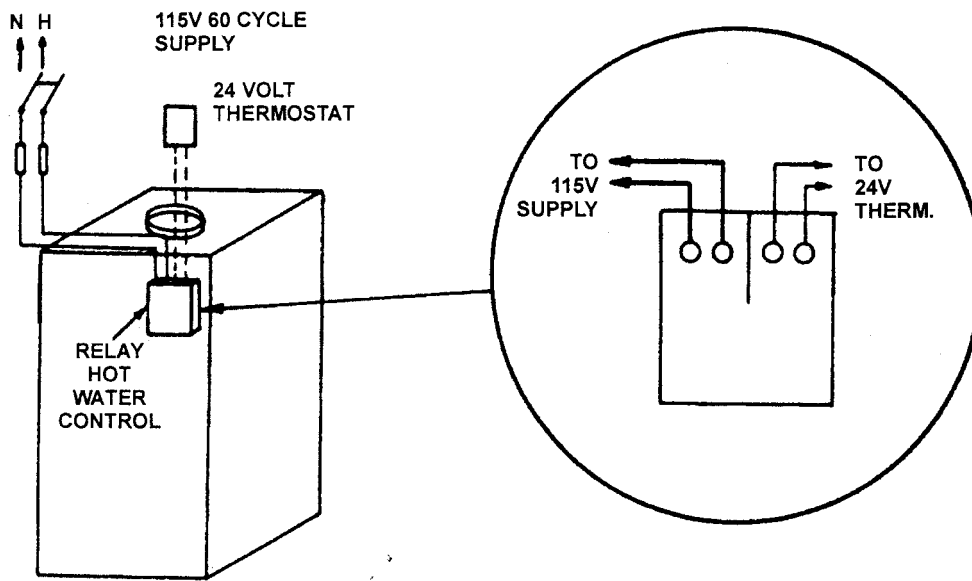

Equipment and Optional Accessories - What They Do

RELIEF VALVE (Provided)

You must have a relief valve on your boiler. Water expands as it is heated. If there is no place for the water to expand into, water pressure will build up inside the boiler and system. Should this happen, the Relief Valve will automatically open at a predetermined pressure. This will relieve the strain on the boiler and system. Run a pipe from the relief valve outlet (pipe must be same size as outlet and the open end must not be threaded) to an open drain, tub or sink, or other suitable drainage point not subject to freezing. Failure to do so may cause water damage or injury should relief valve release. Do not cap off the drain line from this valve !

EXPANSION TANK (Not Provided)

In a properly assembled system, the expanding water flows into an expansion tank. This tank should be of the correct size.

The tank is filled with air. As the water expands it compresses the air in the tank to form an air pressure cushion. This "spring-like" cushion serves to maintain correct operating water pressure regardless of water temperature. This assures a "full measure" of water, even in the highest radiation unit of the system. It also prevents blowing off of the relief valve.

The air in the tank in the beginning (with the system filled with cold water) is sufficient for proper operation. The tank also serves as a trap for excess air in the system. The air would cause gurgling in the pipes and inefficient circulation in the radiators if left in the system.

WARNING

Turn off electric power at fuse box before making any line voltage connections. Follow local electrical codes.

It is possible for a tank to become "water-logged" (filled with water). It can also become overfilled with air. This can happen after filling the system with new water. Fittings provided on the tank and in the line to the tank are for bleeding off excessive water or air.

When installing this tank, it is important: 1) That the tank be higher than the boiler top. 2) That the pipe to the tank continuously rises up to the (so that air can "bubble" up through it).

DIAPHRAGM TYPE EXPANSION TANK (Not Provided)

The Diaphragm Type expansion Tank (EX-TROL) takes the place of the conventional expansion tank. Carefully read the instructions packed with your EX-TROL Tank Assembly.

The EX-TROL Tank comes to you with a 10-12 pounds per square inch air charge. This is the same as the pressure produced in the system is first filled, EX-TROL Tank will contain little or no water.

As the water is heated its pressure increases. It expands into the EX-TROL Tank, compressing the air in the tank. This compressed air cushion permits the water in the system to expand as the temperature changes.

The Diaphragm Type Tank can be mounted on the air purger fitting or at any other convenient place in the supply or return line.

**AIR ELIMINATING FITTING (AIR PURGER)
(Not Provided)**

An Air Purger is used to remove excess air from the system. It is installed in the supply line. It will eliminate air from the water before it reaches the radiators and bleed off this air.

**MAIN AIR VENT FOR DOWN FLOW SYSTEMS OR
DIAPHRAGM TYPE EXPANSION TANK
(Not Provided)**

Before a system is filled with water, there is air in the pipes and radiation units. Some of it will be trapped as the system is filled. It is possible to eliminate most of this air through the air vents on the radiation units. A Main Air vent will speed and simplify this. It should be installed on the highest point in the supply main when all radiation is below top of boiler.

RELAY HOT WATER CONTROL (Provided)

The water temperature limit control in the relay hot water is adjustable and may be set as necessary. It may be set as low as 140 deg. F., or as high as 230 deg. F. This depends on the type and amount of radiation involved and weather conditions.

AUTOMATIC FILL VALVE (Not Provided)

For safe, efficient operation, a hot water system must be filled with water. Adding new water, when needed can be done manually (by use of a hand valve in the water supply line). This requires regular attention to the system's needs. An Automatic Fill Valve accomplishes this without attention. It is installed in the Supply Line on hot water boilers only. The Valve operates through water pressure differentials. It does not require an electrical connection.

DRAIN VALVE (Provided)

This manual valve provides a means of draining all the water from the boiler and systems. It is often installed in the 3/4" tapping at the bottom of the left boiler section. Or it can be installed in a tee where the return line enters the boiler.

CIRCULATING PUMP (Provided)

Every forced Hot-Water system requires a Circulating Pump. A separate pump or zone valve is required for each zone, if you have two or more Zone Systems. This pump must have the capacity to provide the circulation required by your system. The pump may be connected to the supply or the return of the boiler. It is also wired to the electrical system.

Starting Your Boiler

HOW A HOT-WATER SYSTEM OPERATES

Your entire heating system (boiler, piping and radiation units) is filled with water. As the water in the boiler is heated, it is pumped from the top of the boiler through the supply main to the radiation units. The cooler the water in them flows back through the return main to the boiler. This provides positive and rapid response to the thermostat.

FILLING SYSTEM WITH WATER

Close the air vents on all radiation units. Open the Valves to these units. Make sure the boiler and Expansion Tank Drain Cocks are closed. The Air Bleed Screw on the tank Drain Fitting should be closed. Open the valve in the line from the boiler to the expansion tank. Open the water inlet to your boiler and leave it open. Start with the lowest radiation unit. Open the air vent on this unit. When all the air has escaped and water starts to flow from the vent, close it. Go to the next radiation unit, and repeat this process. Repeat until you have covered every radiation unit in the system (ending up at the highest unit in the system). If your units have automatic vents, this manual venting is unnecessary but will speed up the proper filling of your system.

NOTE

After filling - and before operating boiler - check all piping connections for leaks. Slight leaks (which often occur in a newly installed system) are no cause for alarm. They will usually plug themselves in a short time. Leaks which cause a steady trickle must be stopped, however, by tightening the joints.

If your system is a closed expansion tank system, you should have an Automatic Fill Valve. You may leave it open to refill the system automatically as needed. Check the temperature/pressure gauge. Note the position of the hand indicating pressure. This should be between 10 and 15 psi. Any lowering of this movable hand below 10 lbs. will indicate loss of water due to leakage. The automatic fill valve should compensate for this. If it does not, manually open this valve to refill the system until the hand is again pointing to the same pressure reading. Instructions are packaged with the valve.

Operating Your Boiler

IMPORTANT - You or your installer must follow these instructions carefully.

TO START

Fill entire system with water. Vent all air from system. Refer to the instructions included for the oil burner.

FUEL UNITS AND OIL LINES

The oil burner is provided with a single-stage 3450 RPM fuel unit with the by-pass plug removed for a single pipe installation. This is satisfactory where the fuel supply is on the same level, or above burner, permitting gravity flow of oil. never exceed 3 PSI pressure to the suction side of fuel unit. A pressure of over 3 PSI may cause damage to the shaft seat and allow it to leak oil. When it is necessary to lift the oil to the burner, a return line should be run between fuel unit and oil supply. (If lift exceeds 10 feet, a two stage fuel unit must be used with a return line.) When a two line installation is made, the by-pass plug must be installed. This is supplied with the burner attached to fuel unit, along with an information pump data sheet in a plastic bag. When oil lines are installed, continuous runs of heavy wall copper tubing is recommended. Be sure that all connections are absolutely air-tight. Check all connections and joints. Flared fittings are recommended. Do not use compression fittings. See pump data sheet for sizing, lift and length for tubing recommendations. Use an oil filter of adequate size for all installations. Install inside the building between the tank shutoff valve and the burner. For ease of servicing, locate the shutoff valve and filter near the burner.

AIR SUPPLY FOR COMBUSTION

Do not install in rooms with insufficient air to supply combustion. Occasionally, it is necessary to install windows or cut holes in a door to these rooms to obtain sufficient air and to prevent less than atmospheric air pressure in the room. If there is a lack of combustion air, the burner flame will be yellow and formation of soot will occur in the heating unit. In buildings of conventional frame, brick, or stone construction without utility rooms, basement windows, or stair doors, infiltration is normally adequate to provide air for combustion and for operation of the barometric draft control. For installation in an enclosed utility room with an outside wall, a fresh air opening to the outside should be made with a free cross sectional area of twice the area of the outlet or 100 square inches for each gallon nozzle size. (Example: 10 x 10 for 1.00 GPH.) For each 1,000 feet above sea level, increase the fresh air opening by at least four percent. The room should be isolated from any area served by exhaust fans. Do not install an exhaust fan in this room.

DRAFT REGULATORS (Provided)

If a draft regulator is required, it should preferably be mounted in the smoke pipe. Use a draft gauge to adjust to proper opening. When the burner air supply and draft is properly adjusted, the combustion chamber draft will be approximately a negative 0.01" to 0.02" WC and the stack draft will be a negative 0.02" to 0.04" WC. The larger the installation, the greater the draft will be required at the stack to obtain the negative 0.01" to 0.02" WC at the combustion chamber.

NOZZLES (Provided)

Use the proper size, type and spray pattern nozzle. To install nozzle, loosen clamping screw on the retention ring assembly and slide the assembly off the adapter. Install and tighten the nozzle in the adapter. Be careful not to damage the electrode insulators or bend the electrodes. Replace the retention ring assembly on the adapter. Make sure the clamp is tight against the shoulder on the adapter. Tighten the clamping screw. Check electrode setting.

FINAL ADJUSTMENTS (see page 19)

A final adjustment should be made by the use of a COMBUSTION TEST KIT. After operating ten minutes to warmup unit, a smoke tester should be used to take a smoke reading. Smoke test should read no greater than #1 (Shell Bacarach scale), and less than a #1 smoke id desired. At times, a new boiler requires more time than this to burn clean due to the oil film on the new heat exchanger. Recheck draft and take a CO₂ reading over the fire and in the stack. If a large differential between CO₂ readings is noted, air leakage is the most common cause. CO₂ readings must all be taken ahead of draft control, if used. Units should be started and stopped several times to assure good operation. Check operation of limit controls and thermostat. Check for oil leaks.

MAINTENANCE

OIL MOTOR - Only a few drops of non-detergent type oil at both motor holes are needed. Refer to burner manual.
FILTER - The oil filter cartridge should be replaced once each year so the fuel oil will not become contaminated and plug up fuel pump and nozzle of oil burner.
NOZZLE - The nozzle should be changed at least once each year before the start-up of the heating season. Replace with proper nozzle.
COMPONENTS - If for any reason any of the burner parts have to be replaced, always use parts recommended by the manufacturer. Specify part numbers and description when ordering. (IN ALL COMMUNICATIONS STATE BURNER MODEL AND SERIAL NUMBERS.)
ELECTRODE SETTINGS - This is very important for reliable ignition of the oil. Check these once a year in accordance with the instructions provided in this manual.
FAN AND BLOWER HOUSING - This must be kept clean, free of dirt and lint. Open transformer and off cycle damper to check fan blades from above. Be sure the electric power is off on burner when the transformer is opened up for this inspection.

Checking and Adjusting

IMPORTANT - You or your installer must follow these instructions carefully.

OIL BURNER ADJUSTMENT

Refer to your oil burner owners manual for checking and adjusting the burner.

ADJUST OPERATING CONTROLS

Instructions for each control and burner are included. Use the following settings for the first adjustment.

Forced Hot Water - Set limit control at 200 deg. F.

Refer to the instructions for the relay hot water control.

These settings can be changed after you have had some idea how the system works. **Example:** If your Forced Hot Water System does not give quite enough heat in very cold

weather you can raise the limit setting to 220 deg. F. Use the boiler gauge yo check your setting. Make the adjustments according to its readings.

CHECK THERMOSTAT OPERATION

When set above temperature indicated on the thermometer, boiler burner should start. make certain the thermostat turns off the boiler when room temperature reaches the selected setting and starts the boiler operating when room temperature falls a few degrees.

Finally, set the thermostat for the desired temperature. Special conditions in your home and the location of the thermostat will govern this setting.

System Checks After First Starting

These checks and adjustments pertain to the various controls and are to be made in accordance with instructions packaged with the controls and burner.

Set the thermostat for the desired room temperature. Next, adjust the Relay Hot Water Control, which regulates the temperature of the water in the boiler. The temperatures listed in the table (below) have been found to be satisfactory for most installations. They can be varied if necessary, to suit the climate in which you live.

When the thermostat and Relay Hot Water control have been set, start the burner. Watch the thermometer gauge as the boiler warms up and note the temperature at which it stabilizes. If this temperature is not the same as the dial reading on the limit control, re-adjust the control to obtain the desired thermometer indication. (Any difference between this gauge and the control gauge will be due to their different locations. Always use the thermometer gauge when adjusting the controls, for it is the more accurate of the two.)

RECOMMENDED HIGH LIMIT SETTINGS	
Type of Heating Unit	Limit Control Setting
Standing Radiators	180 deg. F.
Baseboard and Convector Radiators	200 deg. F.

RELIEF VALVE

This valve should open automatically when the system pressure exceeds the safe limit (30 pounds per sq. inch). Should it ever fail to open under this condition, shut down you system. Drain it until pressure is reduced below the safe limit. Then have the valve replaced immediately.

EXPANSION TANK

As previously noted, this tank may become waterlogged, or may receive an excess of air. Frequent automatic opening of the relief valve indicates water logging. A higher boiler temperature accompanied by unusually low radiation unit temperature (and "knocking") indicates excess air in tank.

To correct either condition, close the valve between the boiler and the tank. Drain the tank until it is empty. Check all the tank plugs and fittings. Tighten as necessary. Open the valve between the boiler and tank. Water will rise to the normal height in the tank if you have an automatic fill valve (otherwise, manually refill the system).

BOILER FLUE PASSAGES

Under normal operating conditions, with the burners properly adjusted, it should not be necessary to clean the boiler flue gas passages. However, to assure trouble-free operation, we recommend that you have the flue passages, burner adjustment, and operation of the controls checked once each year by a competent Service Technician.

Before the start of each season (or whenever system has been shut down for some time) recheck the whole system for leaks... and recheck the boiler and vent pipe for leaks. Replace or patch any boiler cement seals that are faulty.

WATER SYSTEM

If system is to remain out of service during freezing weather always drain it completely (water left in to freeze will crack the pipes and/or boiler).

Oil Burner Cleaning Instructions

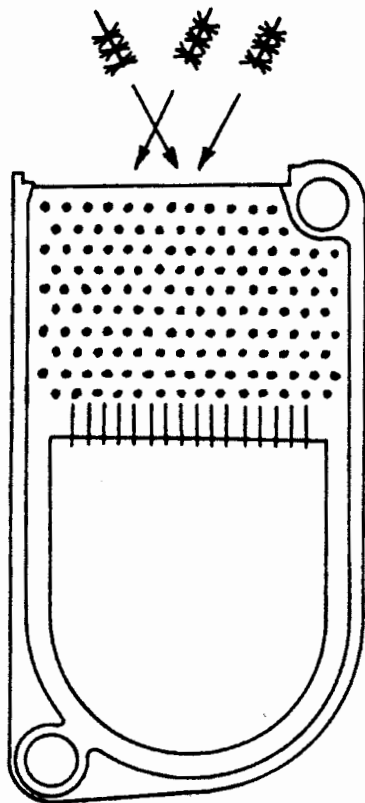

IMPORTANT OPERATING AND MAINTENANCE REQUIREMENTS:
KEEP YOUR BOILER AND THE AREA AROUND IT CLEAN
NEVER BURN REFUSE OR ANY MATERIAL OTHER THAN
THE SPECIFIED FUEL IN YOUR BOILER
HAVE YOUR BOILER CHECKED EACH YEAR BY AN EXPERIENCED TECHNICIAN

STEP 1

Remove the breeching connection to the boiler and remove the top jacket panel. Remove the flue collector by removing the two wing nuts which hold it down.

STEP 2

Remove soot by brushing flue surface diagonally through opening exposed in Step 1.

STEP 3

Vacuum residue from combustion chamber. The best way to do this is to swing out the burner door and carefully insert the vacuum hose into the chamber, then vacuum.

STEP 4

Reassemble boiler. Make sure that flue collector cover is properly sealed. Clean the base of the chimney and replace the breeching. Before leaving the job site, run a combustion test on the unit and make any adjustments needed to obtain the combustion characteristics in the combustion information chart.

OIL BURNER CLEANING:

These are general instructions for cleaning an oil burner. For specifics, consult the burner manufacturer's instructions.

1. Make sure all electrical power to the boiler / burner and the fuel supply to the burner are shut off.
2. With the swing door open, clean any soot accumulations from the end of the burner and if applicable burner head.
3. Remove the burner drawer assembly, clean the electrodes and then reset the electrode spark gap per the manufacturer's recommendations. Refer back to the BURNER MANUFACTURER'S INSTRUCTION MANUAL.
4. Replace the oil nozzle with the exact same size and type recommended for use on this boiler.
5. Reinstall the burner drawer assembly making sure the head location (and size if applicable) are per the burner manufacturer's recommendations. If the burner being used has a damaged head, replace the head with the exact same head recommended for use on this boiler.
6. Inspect and clean the blower wheel.
7. Remove the oil pump cover and clean / replace the pump screen. Carefully reassemble ensuring the pump cover makes a proper seal.
8. Securely fasten the swing door shut.
9. Replace the fuel filter (if applicable).
10. Reconnect the electrical and fuel supplies.
11. Fire the burner, checking for proper combustion using combustion test equipment and making adjustments as necessary. Refer to the section in this manual on OPERATING THE BOILER - Final Burner Adjustments.
12. Insure that all safety controls and operating controls are functioning properly.

Service Hints

You may avoid inconvenience and service calls by checking these points before you call for service.

<p>Possible Cause</p> <p>Thermostat is not set correctly</p> <p>Boiler and/or Burner may be dirty</p> <p>Burner may not be firing at proper rate</p> <p>Burner may be short-cycling</p> <p>No power to boiler</p> <p>Controls out of adjustment</p> <p>Radiators not heating</p> <p>Circulating pump not running</p> <p>Poor electrical contact</p>	<p>What to do</p> <p>Reset thermostat above room temperature.</p> <p>Clean all flue passages and the vent pipe. Have burner cleaned and readjusted.</p> <p>Check nozzle size if there is any doubt. Have burner adjusted.</p> <p>Short-cycling (too frequent off and on) of burner will cause sooting. If boiler and/or burner become dirty at frequent intervals, after correcting the "dirt condition" also correct the control setting (or other cause of the short-cycling). Check thermostat heat anticipator and correct setting, if necessary, per instruction sheet packed with thermostat.</p> <p>Check fuse. If blown, replace. Check to be sure power supply circuit is "ON".</p> <p>Reset according to instructions packed with controls.</p> <p>Open radiator vents to vent excess air. Check flow valve control (if used). It may be in closed position.</p> <p>Check relay operation.</p> <p>Check all control terminals and wire joints.</p>
<p>Possible Cause</p> <p>Oil burner fan wheel may be dirty</p> <p>Draft regulator may be stuck</p>	<p>What to do</p> <p>Clean fan wheel with a stiff brush and cleaning solvent. Readjust oil burner.</p> <p>Check to see if vane swings freely. Clean, if vane is stuck.</p>
<p>Possible Cause</p> <p>Air in system</p>	<p>What to do</p> <p>Open radiator vents to vent air. Check expansion tank.</p>
<p>Possible Cause</p> <p>Dirt on seat</p> <p>Water logged expansion tank</p>	<p>What to do</p> <p>Open valve manually. Allow water to run and clear valve seat.</p> <p>Drain tank, see instructions.</p>

HAVE YOUR SERVICE TECHNICIAN CHECK ANY PROBLEM YOU ARE UNABLE TO CORRECT.

Electrical Wiring

BOILER WITH TANKLESS HEATER COIL

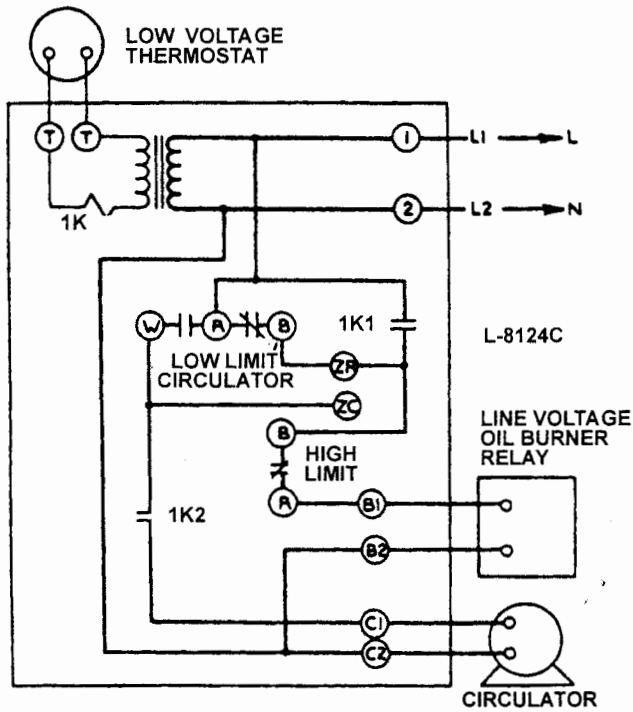

BOILER WITHOUT TANKLESS HEATER COIL

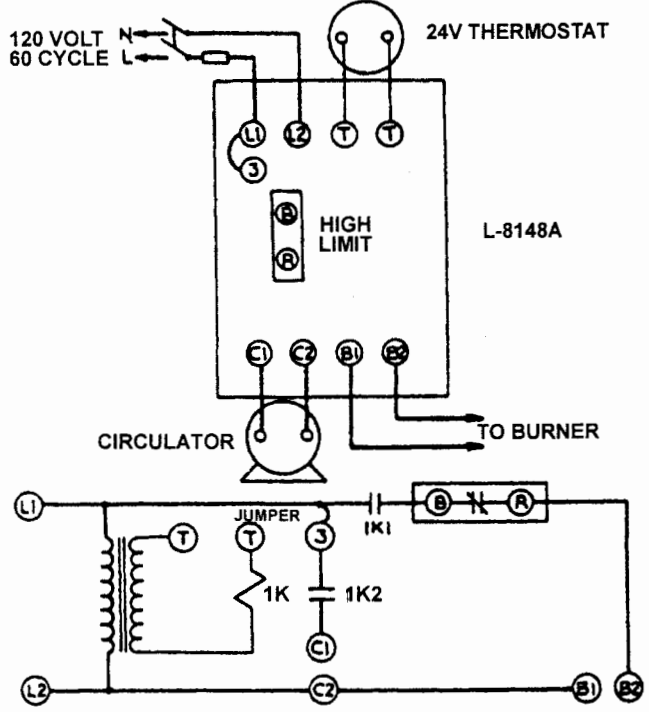

FOR OPTIONAL WIRING - SEE BACK PAGE

Recommended Tankless Coil Piping

**BDS BOILER WITH COIL
(AQUASTAT NOT SHOWN)**

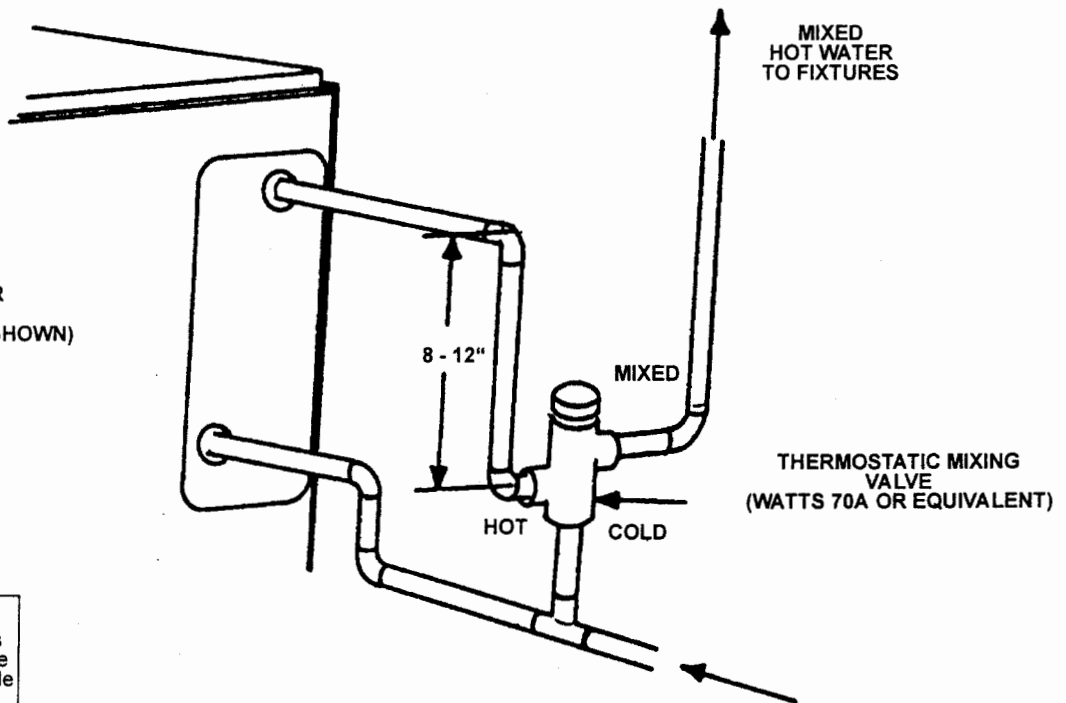

WARNING
Thermostatic mixing valves are intended to increase the supply of hot water available from the coil. they are not intended to prevent a scald hazard.

Repair Parts

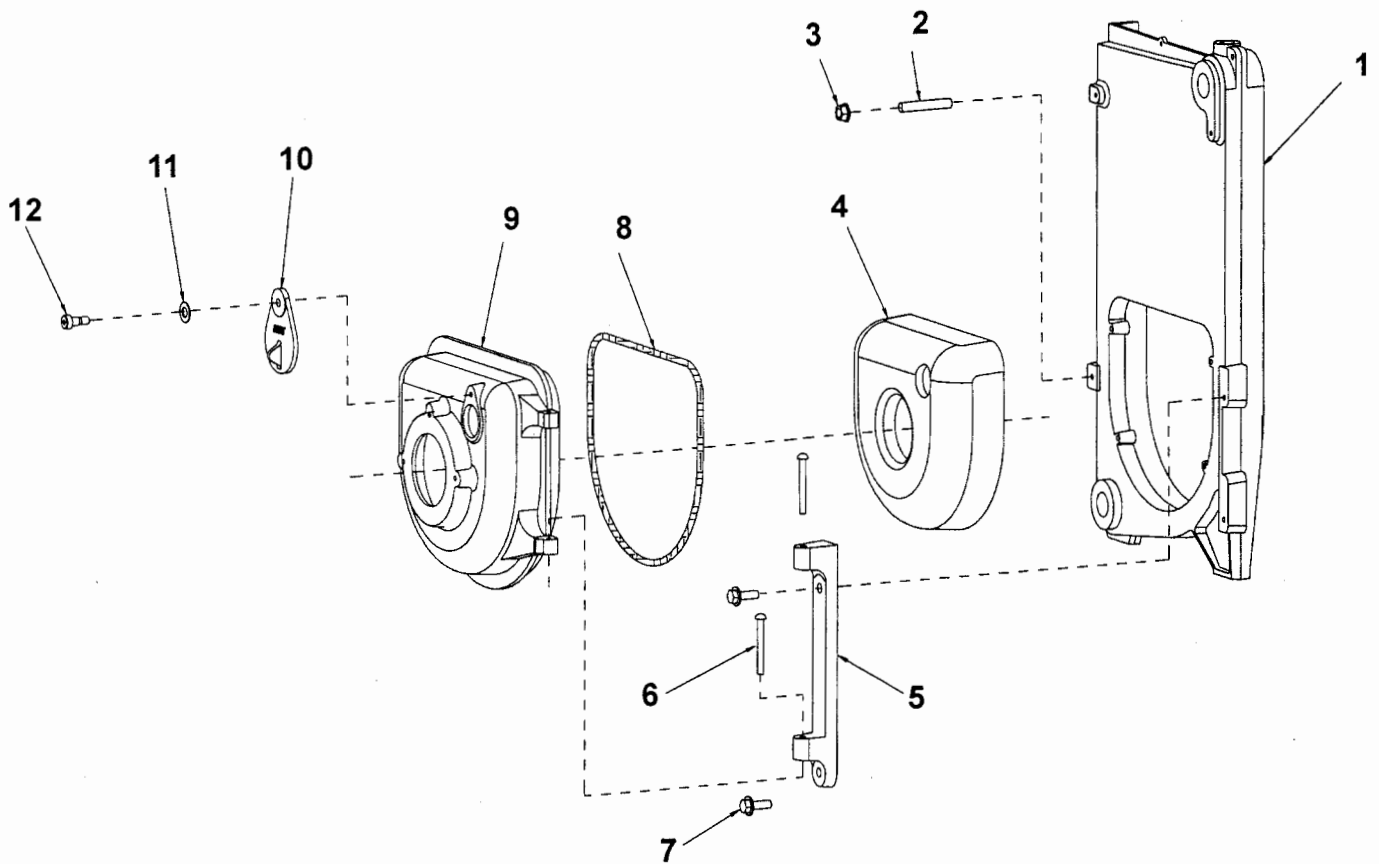

KEY	DESCRIPTION	PART #	QTY
1	Front Section	403-00-006	1
2	3/8" - 16 x 2-1/4" Stud	146-95-125	1
3	3/8" Whizlock Nut	146-95-126	1
4	Swing Door Insulation	146-14-014	1
5	Swing Door Hinge	403-00-010	1
6	1/4" x 2" Round Head Rivet	146-95-121	2
7	3/8" x 1" Hex Head Serrated Flange Bolt	146-95-124	2
8	3/8" x 48" Fiberfrax Round Braid	433-00-905	1
9	Swing Door	403-00-009	1
10	Flame Observation Door	403-00-014	1
11	5/16" Lock Washer	146-95-123	1
12	3/8" x 3/8" Shoulder Bolt 5/16" - 18 Thread	146-95-122	1

Jacket Parts

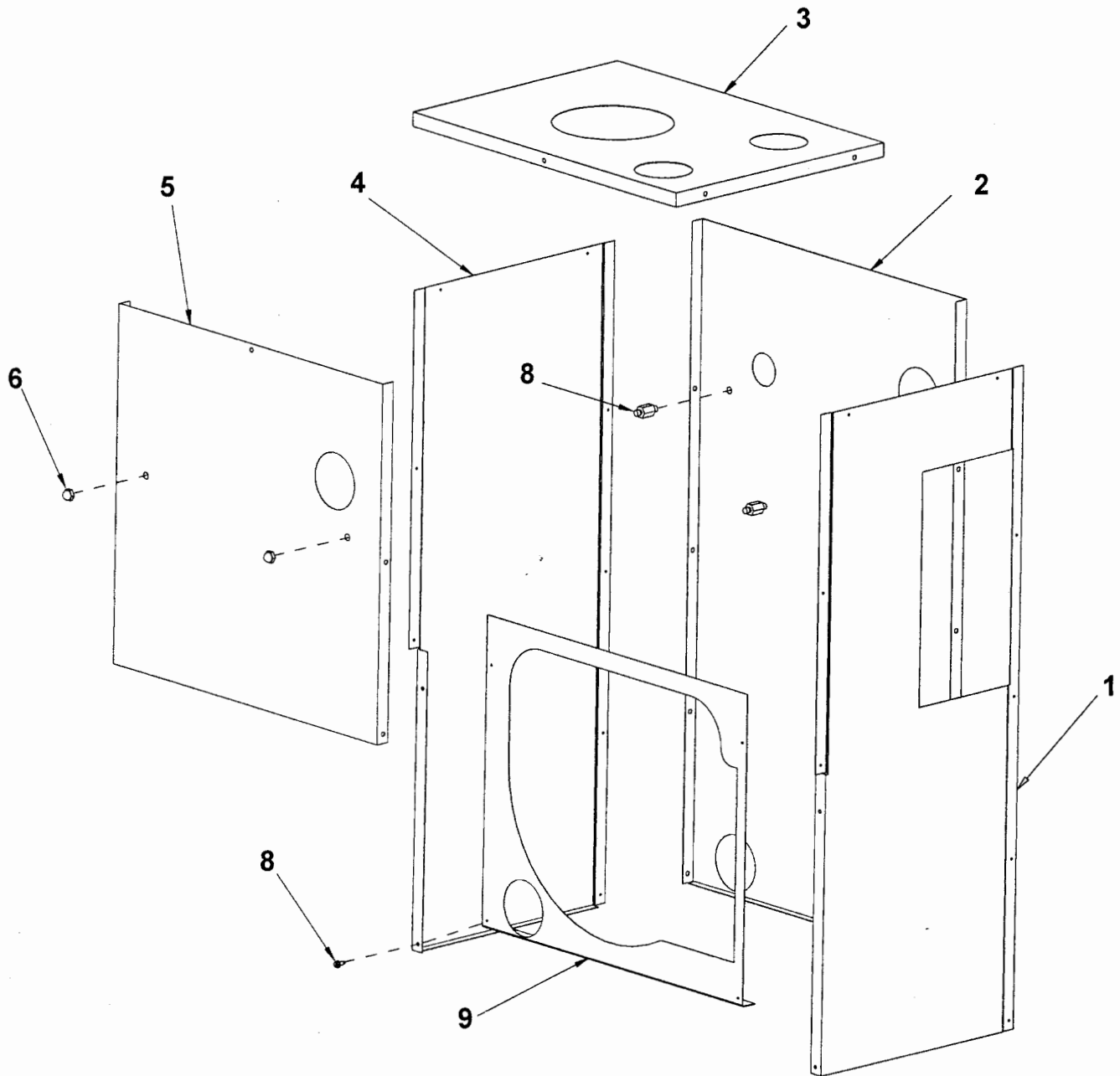

KEY	DESCRIPTION	QTY	BDS 080-119	BDS 111-178	BDS 147-236
1	Right Side Jacket Panel	1	425-00-244	425-00-245	425-00-246
2	Back Jacket panel	1	425-00-269	425-00-269	425-00-269
3	Top jacket Panel	1	425-00-254	425-00-255	425-00-256
4	Left Side Jacket Panel	1	425-00-264	425-00-265	425-00-266
5	Upper Front Jacket Panel	1	425-00-267	425-00-267	425-00-267
6	5/16" Acorn Nut	4	146-95-042	146-95-042	146-95-042
7	#10 x 1/2" Jacket Screw	21	146-95-074	146-95-074	146-95-074
8	Stand Off	4	146-95-103	146-95-103	146-95-103
9	Lower Front Jacket Panel (boiler w/ swing door)	1	425-00-268	425-00-268	425-00-268
xx	Complete Jacket for Boiler with Swing Door	XX	425-00-289	425-00-290	425-00-291

Block Parts

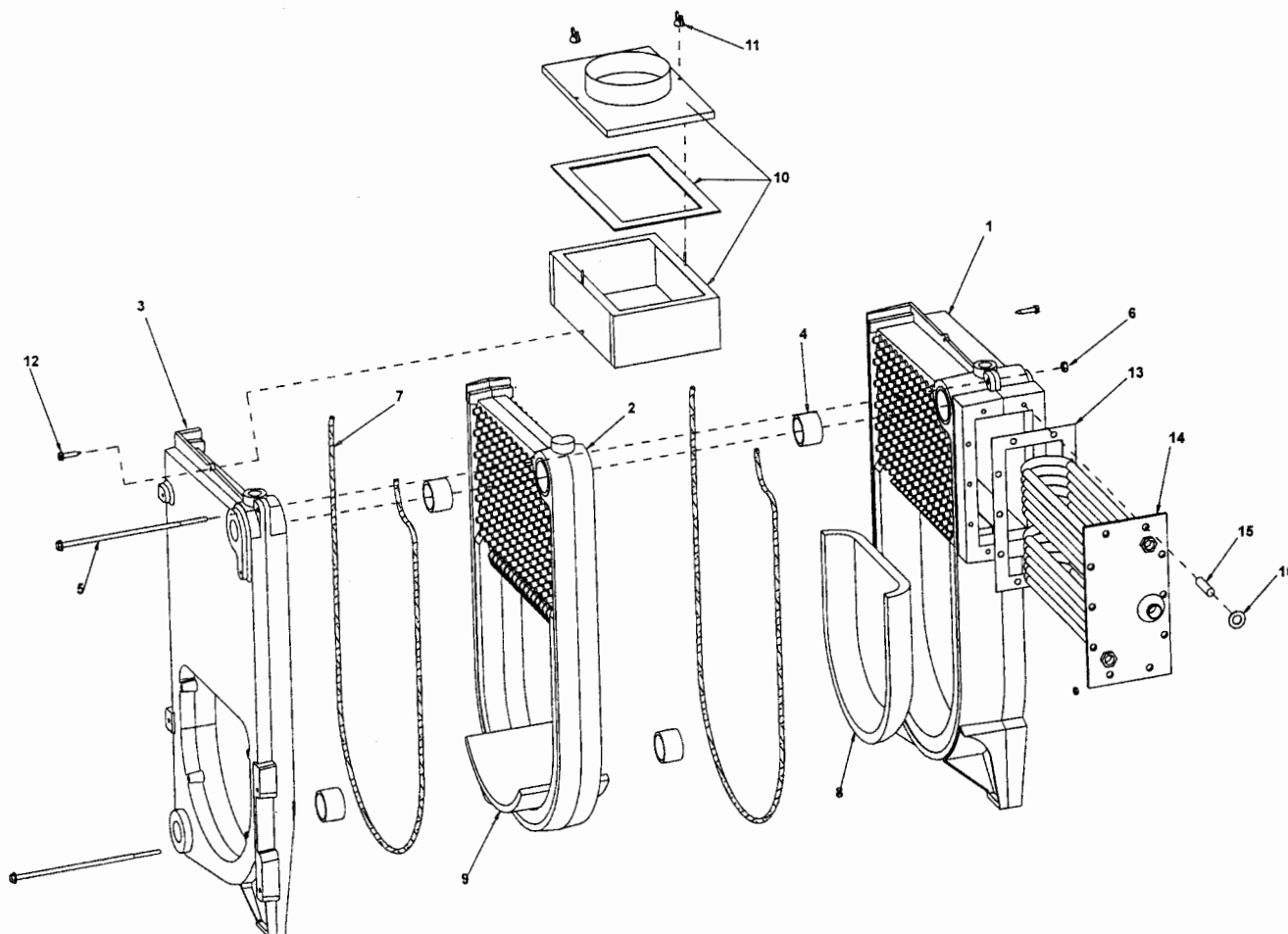

KEY	DESCRIPTION	QTY	BDS 080-119	BDS 111-178	BDS 147-236
1	BDS Rear Section	1	403-00-008	403-00-008	403-00-008
2	BDS Mid Section	xx	403-00-007	403-00-007	403-00-007
3	BDS Front Section	1	403-00-006	403-00-006	403-00-006
4	Cast Iron Push Nipple 2"	xx	433-00-976	433-00-976	433-00-976
5	1/4" Tie Rods	2	146-05-002	146-05-051	146-05-053
6	Tie Rod 1/4" - 20 Hex Head Nut	2	146-95-041	146-95-041	146-95-041
7	5/16" x 70-1/2" Braided Rope	1	433-00-955	433-00-955	433-00-955
8	Target Wall	1	146-19-003	146-19-003	146-19-003
9	Insulation Blanket	1	17-010	17-011	17-012
10	Flue Collector	1	425-00-279	425-00-280	425-00-281
11	8/32" Brass Wing Nut	2	137-04-007	137-04-007	137-04-007
12	#14 x 3/4" Hex Washer Head Screw	2	146-95-070	146-95-070	146-95-070
13	Coil Gasket	1	17-001	17-001	17-001
14	Tankless Coil	1	17-002	17-002	17-002
15	(Coil Bolt) 3/8" - 16 x 3/4" Cap Screw	10	90-035	90-035	90-035
16	(Coil Bolt Washer) 3/8" USS Flat Washer	10	90-036	90-036	90-036
17	Blank Coil Plate	1	17-003	17-003	17-003

REPAIR PARTS

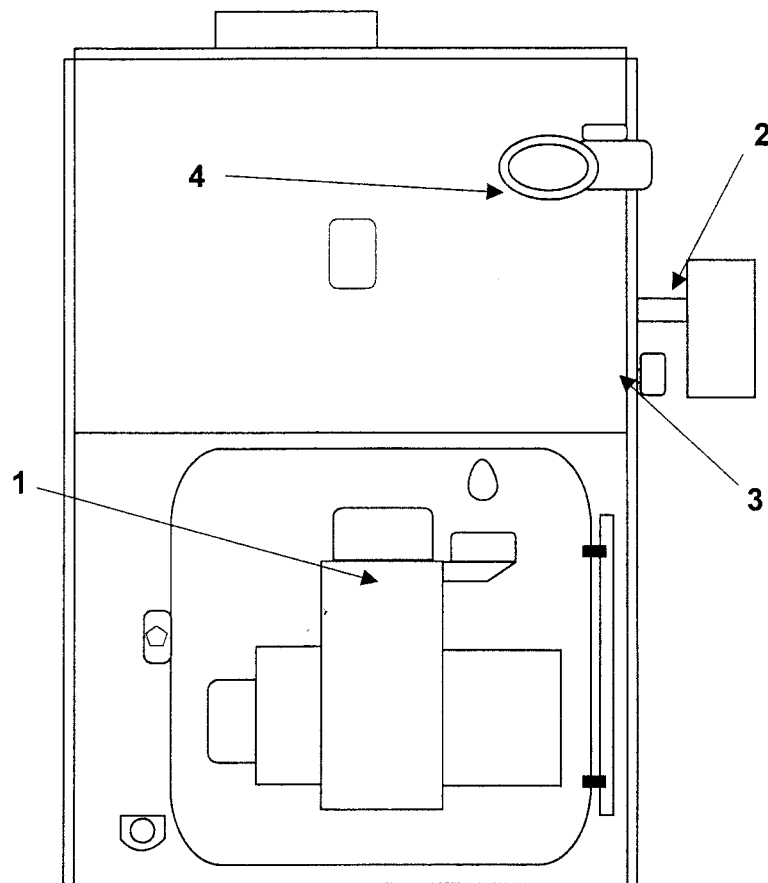

CROWN BAHAMA (BDS-SERIES) COMPONENT PARTS

KEY #	PART #	DESCRIPTION
1	13-016	C11407 BECKETT AFG-MB BURNER
1	13-017	C11408 BECKETT AFG-MD BURNER
2	35-3030	L8124C1102 AQUASTAT RELAY (W/COIL)
2	35-3010	L8148A1124 AQUASTAT RELAY (L/COIL)
3	95-038	TEMP. / PRESS. GAUGE (RESIDENTIAL)
4	95-012	TACO 007 CIRCULATOR
4	95-013	GRUNDFOS UP15-42F CIRCULATOR
*** NOT PICTURED ***		
***	35-1010	123870A SHORT WELL
***	13-020	6" BAROMETRIC DRAFT REGULATOR
***	35-5100	R8184G1427 BURNER PRIMARY RELAY
***	13-038	SUNTEC C642N OIL SOLENOID VALVE KIT
***	13-095	5878-U BECKETT TRANSFORMER
***	13-096	2460-U BECKETT 140psi 1-STAGE OIL PUMP
***	13-099	2456-U BECKETT BURNER MOTOR

BURNER COMBUSTION DATA

BECKETT	BDS-80	BDS-92	BDS-119	BDS-111	BDS-150	BDS-178	BDS-147	BDS-209	BDS-236
BURNER MODEL	AFG	AFG	AFG	AFG	AFG	AFG	AFG	AFG	AFG
INSERTION LENGTH	2 1/4	2 1/4	2 1/4	2 1/4	2 1/4	2 1/4	2 1/4	2 1/4	2 1/4
AIR TUBE COMBO.	AFG50MB	AFG50MB	AFG50MB	AFG50MB	AFG50MD	AFG50MD	AFG50MD	AFG50MD	AFG50MD
COMBU VALVE	E7	E7	E7	E7	E7	E7	E7	E7	E7
LOW FIRING RATE BAFFLE	BECKETT #31760	-	-	BECKETT #31760	-	-	-	-	-
HEAD SETTING	-	-	-	-	0	2	0	2	3
STANDARD NOZZLE	DELAVAN 0.60/80B*	DELAVAN 0.65/70B	MONARCH 0.85/80AR	DELAVAN 0.75/70B	DELAVAN 1.10/70B	DELAVAN 1.25/60B	DELAVAN 1.00/70B	DELAVAN 1.50/60B	DELAVAN 1.65/60B
ALTERNATE NOZZLE	-	-	DELAVAN 0.85/60B	-	-	-	-	-	MONARCH 1.65/45R
PUMP PRESS (psi)	140	140	140	140	140	140	140	140	140
SHUTTER TYPE	STD.	STD.	STD.	STD.	STD.	STD.	STD.	STD.	STD.
STARTING: SHUTTER SETTING	6	6	10	10	10	10	10	10	10
BAND SETTING	0	0	1	1	2	2	1	4	3
DRAFT IN FLUE (in w.c.)	-0.02	-0.02	-0.02	-0.02	-0.02	-0.02	-0.02	-0.02	-0.02
MAX. SMOKE (bacharach scale)	#1	#1	#1	#1	#1	#1	#1	#1	#1
MIN. CO2 (%)	11.0	11.0	11.0	11.0	11.0	11.0	11.0	11.0	11.0
MAX. CO2 (%)*	13.0	13.0	13.0	13.0	13.0	13.0	13.0	13.0	13.0

* "DEL-O-FLOW" NOZZLE PREFERRED

RIELLO	BDS-80	BDS-92	BDS-119	BDS-111	BDS-150	BDS-178	BDS-147	BDS-209	BDS-236
BURNER MODEL	F5	F5	F5	F5	F5	F5	F5	F10	F10
INSERTION LENGTH	2 1/4	2 1/4	2 1/4	2 1/4	2 1/4	2 1/4	2 1/4	2 1/4	2 1/4
TURBULATOR SETTING	0.5	2.0	2.0	1.5	2.5	4.0	2.5	2.0	2.5
STANDARD NOZZLE	DELAVAN 0.50/70W	DELAVAN 0.65/70W	DELAVAN 0.85/70W	DELAVAN 0.75/70W	DELAVAN 1.00/70W	DELAVAN 1.25/70W	DELAVAN 1.00/70W	DELAVAN 1.50/70W	DELAVAN 1.75/70W
PUMP PRESS (psi)	145	145	145	145	145	145	145	145	145
AIR SHUTTER SETTING	2.0	2.2	3.2	2.6	3.8	7.0	3.5	3.8	4.1
DRAFT IN FLUE (in w.c.)	-0.02	-0.02	-0.02	-0.02	-0.02	-0.02	-0.02	-0.02	-0.02
MAX. SMOKE (bacharach scale)	#1	#1	#1	#1	#1	#1	#1	#1	#1
MIN. CO2 (%)	11.0	11.0	11.0	11.0	11.0	11.0	11.0	11.0	11.0
MAX. CO2 (%)*	13.0	13.0	13.0	13.0	13.0	13.0	13.0	13.0	13.0

CARLIN	BDS-80	BDS-92	BDS-119	BDS-111	BDS-150	BDS-178	BDS-147	BDS-209	BDS-236
BURNER MODEL	EZ-1 HP	EZ-1 HP	EZ-1 HP	EZ-1 HP	EZ-1 HP	EZ-1 HP	EZ-1 HP	EZ-2 HP	EZ-2 HP
INSERTION LENGTH	2 1/4	2 1/4	2 1/4	2 1/4	2 1/4	2 1/4	2 1/4	2 1/4	2 1/4
HEAD BAR	0.50	0.60/0.65	0.85/1.00	0.75	0.85/1.00	1.10/1.25	0.85/1.00	1.50	1.65/1.75
STANDARD NOZZLE	DELAVAN 0.55/70B	DELAVAN 0.65/60B	DELAVAN 0.85/60B	DELAVAN 0.75/60B	DELAVAN 1.00/60B	DELAVAN 1.25/60B	DELAVAN 1.00/60B	DELAVAN 1.50/60B	DELAVAN 1.65/70B
PUMP PRESS (psi)	150	150	150	150	150	150	150	150	150
AIR SHUTTER SETTING	0.52	0.60	0.80	0.75	0.90	1.25	0.90	1.65	1.95
DRAFT IN FLUE (in w.c.)	-0.02	-0.02	-0.02	-0.02	-0.02	-0.02	-0.02	-0.02	-0.02
MAX. SMOKE (bacharach scale)	#1	#1	#1	#1	#1	#1	#1	#1	#1
MIN. CO2 (%)	11.0	11.0	11.0	11.0	11.0	11.0	11.0	11.0	11.0
MAX. CO2 (%)*	13.0	13.0	13.0	13.0	13.0	13.0	13.0	13.0	13.0

OPTIONAL WIRING

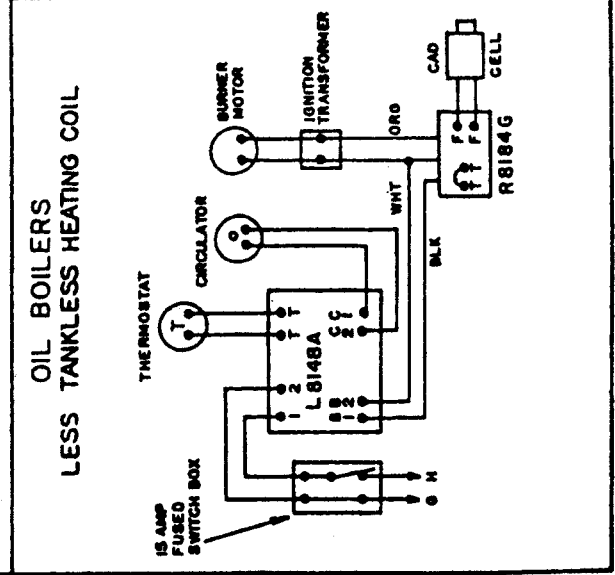
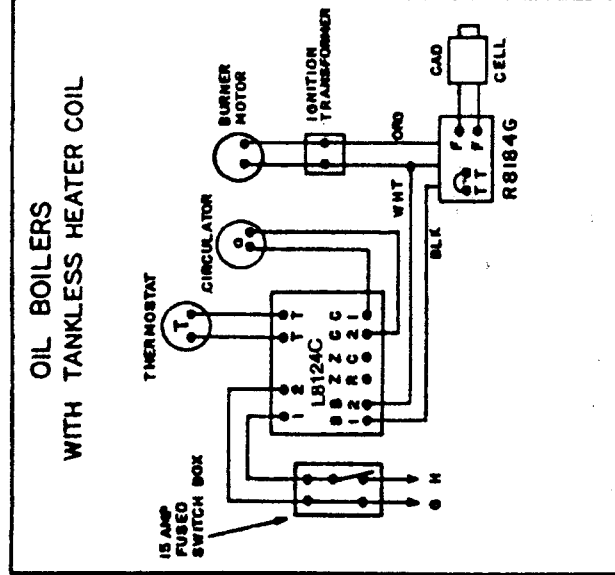
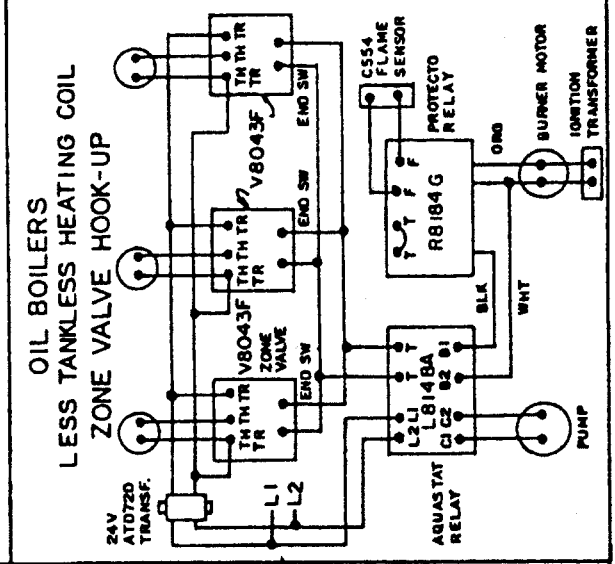
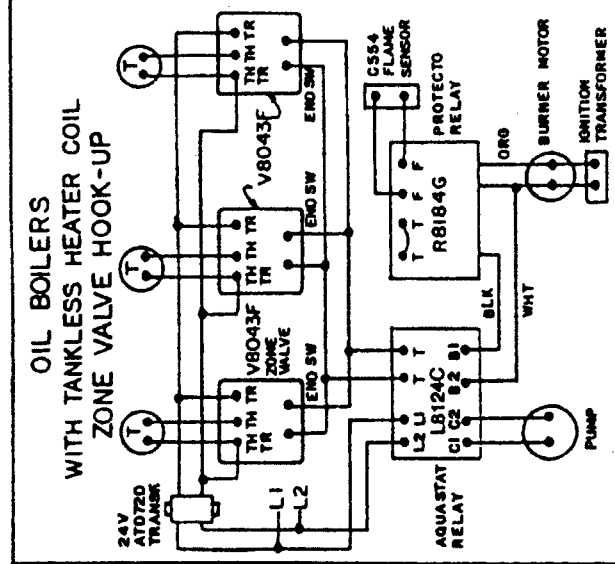
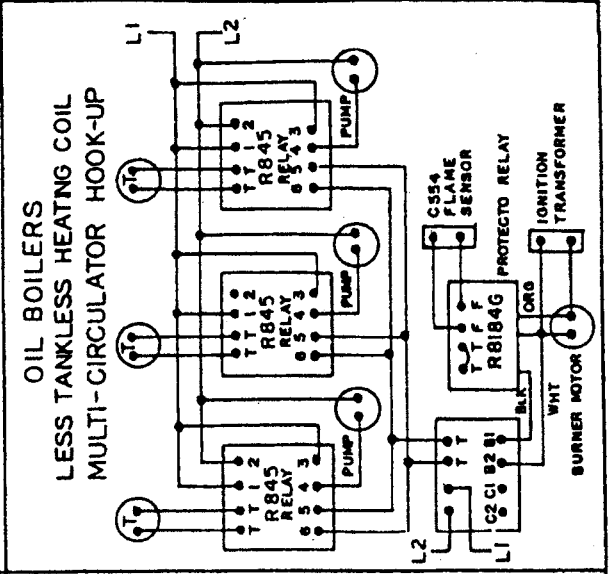
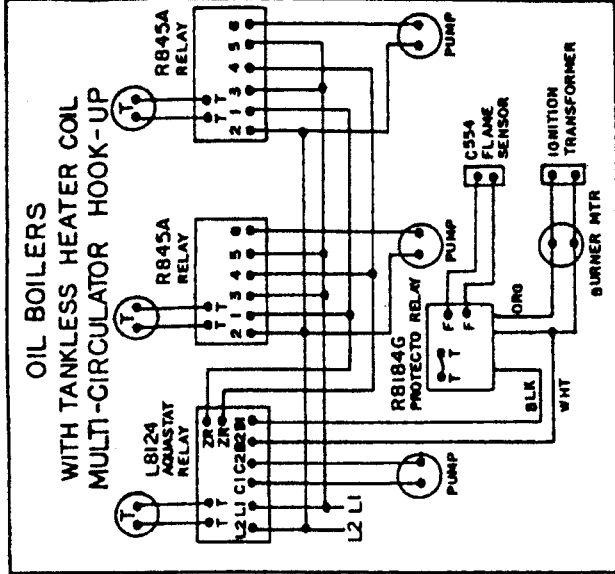

NOTES



CROWN BOILER CO

P.O. Box 14818 3633 "I" Street Philadelphia, PA 19134

WWW.CROWNBOILER.com