

INSTALLATION MANUAL

DOWNFLOW/UPFLOW ELECTRIC FURNACE

MODELS: EB

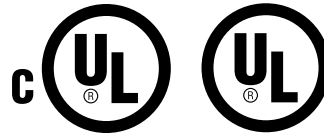

LIST OF SECTIONS

GENERAL	1	THERMOSTAT INSTALLATION	8
SAFETY	2	OPTIONAL AIR CONDITIONING ACCESSORIES	9
UNIT INSTALLATION	2	WIRING DIAGRAMS	10
DOWNFLOW FURNACE INSTALLATION	3		

LIST OF FIGURES

Furnace Dimensions	1	Blower Bracket and Duct Flange Attachment	6
Upflow Closet Clearances	3	Control Box	7
Duct Connector Depth (7990 Series)	3	Field Wiring Shield	8
Duct Connector Dimensions (7990 Series)	4	Thermostat Wiring	8
Recommended Floor Cut-out (7990 Series)	4	Thermostat Wiring	8
Duct Connector Screw Attachment (7990 Series)	4	EB10C Wiring Diagram	10
Duct Connector Tab Attachment (7990 Series)	4	EB12C Wiring Diagram	10
Duct System Configuration	5	EB15C Wiring Diagram	11
Installation of Furnace	5	EB17C Wiring Diagram	11
Hanger Angle Attachment	5	EB20C Wiring Diagram	12
		EB23C Wiring Diagram	12

LIST OF TABLES

Duct Connector for Electric Furnaces	3	EB Series Blower Performance	7
Wiring Requirements	6	Electrical Data	7

SECTION I: GENERAL

The following list includes important facts and information regarding the EB furnace and its packaging inclusions:

1. Furnace is rated at 240 volts, 60 Hz, single phase.
2. Heating and Cooling thermostat is packed with furnace.
3. Filters are furnished with each model, and are the same for all models - 16 x 20 x 1.
4. Furnace size is the same for all models. See Figure 1.
5. Four-wire thermostat operation for heating and cooling.
6. Coil cavity built into furnace.
7. All furnaces are equipped with an air conditioner blower and is A/C or Heat Pump ready.
8. Holding strap furnished on top rear of furnace.
9. This furnace is designed for downflow application; however, it may be converted to an upflow application. (See Page 6 for upflow conversion instruction.)
10. This furnace must not be operated without the front panel installed.

NOTE: This furnace and its components listed on the A/C and Heat Pump equipment sticker were listed in combination as a system by Underwriter's Laboratories for the United States and Canada.

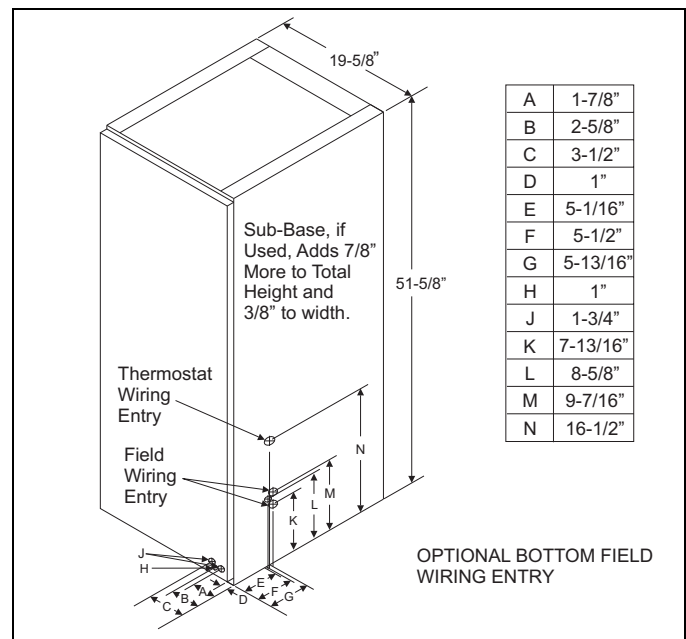

FIGURE 1: Furnace Dimensions

CLICK ANYWHERE on THIS PAGE to RETURN to COLEMAN HVAC HISTORY & GUIDES at InspectApedia.com

SECTION II: SAFETY



This is a safety alert symbol. When you see this symbol on labels or in manuals, be alert to the potential for personal injury.

Understand and pay particular attention to the signal words **DANGER**, **WARNING**, or **CAUTION**.

DANGER indicates an **imminently** hazardous situation, which, if not avoided, **will result in death or serious injury**.

WARNING indicates a **potentially** hazardous situation, which, if not avoided, **could result in death or serious injury**.

CAUTION indicates a potentially hazardous situation, which, if not avoided **may result in minor or moderate injury**. It is also used to alert against unsafe practices and hazards involving only property damage.

WARNING

Improper installation may create a condition where the operation of the product could cause personal injury or property damage. Improper installation, adjustment, alteration, service or maintenance can cause injury or property damage. Refer to this manual for assistance or for additional information, consult a qualified contractor, installer or service agency.

CAUTION

This product must be installed in strict compliance with the installation instructions and any applicable local, state, and national codes including, but not limited to building, electrical, and mechanical codes.

WARNING

FIRE OR ELECTRICAL HAZARD
Failure to follow the safety warnings exactly could result in serious injury, death or property damage. A fire or electrical hazard may result causing property damage, personal injury or loss of life.

1. Install this electric furnace only in a location and position as specified in SECTION III of these instructions.
2. Always install the electric furnace to operate within the electric furnace's intended maximum outlet air temperature. Only connect the air handler to a duct system which has an external static pressure within the allowable range, as specified on the EB rating plate.
3. When an electric furnace is installed so that supply ducts carry air circulated by the air handler to areas outside the space containing the air handler, the return air shall also be handled by duct(s) sealed to the air handler casing and terminating outside the space containing the air handler.
4. The electric furnace is not to be used for temporary heating of buildings or structures under construction.
5. The size of the unit should be based on an acceptable heat loss or gain calculation for the structure. ACCA, Manual J or other approved methods may be used.

SAFETY REQUIREMENTS

1. This electric furnace should be installed in accordance with all national and local building/safety codes and requirements, local plumbing or wastewater codes, and other applicable codes.
2. Refer to the unit rating plate for the EB model number, and then see the dimensions page of this instruction for supply air plenum dimensions in Figure 3. The plenum must be installed according to the instructions.

3. Provide clearances from combustible materials as listed under Clearances to Combustibles.
4. Provide clearances for servicing ensuring that service access is allowed for electric furnace elements and blower.
5. Failure to carefully read and follow all instructions in this manual can result in electric furnace malfunction, death, personal injury and/or property damage.
6. Check the rating plate and power supply to be sure that the electrical characteristics match.
7. Electric furnace shall be installed so the electrical components are protected from water.
8. Installing and servicing heating/cooling equipment can be hazardous due to the electrical components. Only trained and qualified personnel should install, repair, or service heating/cooling equipment. Untrained service personnel can perform basic maintenance functions such as cleaning and replacing the air filters. When working on heating/cooling equipment, observe precautions in the manuals and on the labels attached to the unit and other safety precautions that may apply.
9. These instructions cover minimum requirements and conform to existing national standards and safety codes. In some instances these instructions exceed certain local codes and ordinances, especially those who have not kept up with changing residential and non-HUD modular home construction practices. These instructions are required as a minimum for a safe installation.

INSPECTION

As soon as a unit is received, it should be inspected for possible damage during transit. If damage is evident, the extent of the damage should be noted on the carrier's freight bill. A separate request for inspection by the carrier's agent should be made in writing. Also, before installation the unit should be checked for screws or bolts, which may have loosened in transit. There are no shipping or spacer brackets which need to be removed.

Also check to be sure all accessories such as heater kits, suspension kits, and coils are available. Installation of these accessories or field conversion of the unit should be accomplished before setting the unit in place or connecting any wiring, electric heat, ducts or piping.

CODES

The electric furnace must be installed in accordance with the following codes:

- Standard for the Installation of Air Conditioning and Ventilating Systems (NFPA 90A)
- Standard for the Installation of Warm Air Heating and Air Conditioning Systems (NFPA 90B)
- National Electric Code (NFPA 70)
- Canadian Electrical Code, Part I (CSA C22.1)
- All local codes (state/county/township).

NOTE: All applicable codes take precedence over any recommendation made in these instructions.

SECTION III: UNIT INSTALLATION

LOCATION

Access for servicing is an important factor in the location of any furnace. Provide a minimum of 24" (61 cm) in front of the furnace for access to the heating elements and controls. This access may be provided by a closet door or by locating the furnace 24" (61 cm) from a facing wall or partition.

FURNACE CLEARANCE

Electric furnace is approved for zero (0) in. clearance to combustible material on all or any part of the furnace exterior and the inlet or outlet duct work. For furnaces installed in upflow application, there must be 1" (2.54 cm) clearance from the outlet duct work for a distance of 3 feet (91.4 cm) from the supply air opening.

RETURN AIR

In order for the furnace to work properly, a closet or alcove must have a certain total free area opening for return air.

For Heating Only Furnace

Minimum 200 in² (1290 cm²) free area opening.
Use Return Grille 7900-287P/B, or any Return Grille with minimum 200 in² free area opening.

For A/C and HP Applications (Standard Blower)

Minimum 250 in² (1613 cm²) free area opening. Use accessory blower package 3500-7901, or use Return Grille 7900-287P/B, 1FG0620BK (hinged), or Louvered Door 3500-1581, 3500-5851 (bulk pack), or any Return Grille with minimum 250 in² (1613 cm²) free area opening.

For A/C and HP Applications (Accessory Blower)

Minimum 330 in² (2129 cm²) free area opening. Use 5 ton blower accessory 3500-7901 use Return Grille 1RF1025BK, 1FG0125 (hinged), or Louvered Door 3500-1591, 3500-5861 (bulk pack), or any Return Grille with minimum 330 in² (2129 cm²) free area opening.

The return air opening can be located in a closet front door or a sidewall above the furnace casing, or in a louvered door on the furnace. If opening for the return air is located in the floor, side walls or closet door anywhere below furnace casing height, 6" (15.2 cm) minimum clearance must be provided on the furnace side where return is located to provide for proper air flow. See Figure 2. The 6" (15.2 cm) minimum clearance is not required if there is a return grille installed above the furnace height. This return grille cannot start more than three feet above the furnace height.

For Upflow installations, a closet 32" (81.3 cm) wide by 30" (76.2 cm) deep with a 30" (76.2 cm) wide door is necessary. See Figure 3.

When installing furnace in a separate closet or room which is accessible only through an outside door, a minimum of 200 in² (1290 cm²) free opening for return air must be provided. The supply and return air must be ducted, securely attached and be sealed to the furnace casing if there are grilles in the outside door to the closet. Openings where ducts pass through walls, the floor or the ceiling must be sealed to prevent air leakage into or from closet and the living area.

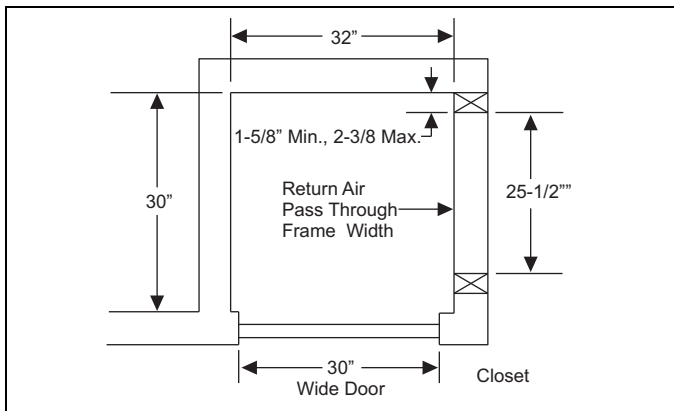

FIGURE 2: Upflow Closet Clearances

Provisions shall be made to permit the return of circulating air from all rooms and living spaces, except the bathroom(s) to the circulating air supply inlet of the furnace. Failure to comply may cause improper heating and may cause the furnace to cycle on the limit.

DUCT SYSTEM DESIGN

Electric furnace is designed to operate at a given static pressure. In order to assure proper air flow through the furnace, the distribution system must be designed so that the static pressure external to the furnace does not exceed the static pressure rating shown on the furnace rating plate.

The number, size and placement of registers should be such that even distribution of heat is provided throughout the home.

SECTION IV: DOWNFLOW FURNACE INSTALLATION

7900 SERIES DUCT CONNECTOR

We have designed our duct connector to eliminate a sub-base requirement. Table 1 will help you in deciding the part number of the duct connector you need.

Provide adequate clearance for servicing.

1. Locate furnace conveniently away from wall facing or partitions to permit easy removal of components.
2. A six (6) inch space minimum should be maintained between the furnace and closet door when door is used for return air.
3. Two (2) feet of space must be available in front of furnace for future servicing (blower, element or furnace removal, etc.).

TABLE 1: Duct Connector for Electric Furnaces

FLOOR TO DUCT DIMENSIONS	FINGERED STYLE	SCREW TAB STYLE
1" (2.54 cm)	7990-6211	7990-6011
2" (5.1 cm)	7990-6221	7990-6021
3" (7.6 cm)	↑↓	↑↓
4" (10.2 cm)	7990-6241	7990-6041
5" (12.7 cm)	↑↓	↑↓
6" (15.2 cm)	7990-6261	7990-6061
7" (17.8 cm)	7990-6271	7990-6071
8" (20.3 cm)	7990-6281	7990-6081
9" (22.8 cm)	↑↓	↑↓
10" (25.4 cm)	7990-6301	7990-6101
11" (28.2 cm)	↑↓	↑↓
12" (30.5 cm)	7990-6321	7990-6121
13" (33 cm)	↑↑	↑↑

- ↑↓ - Indicates connector above or below could be used depending on tolerance in floor to duct dimension.
- ↑↑ - Indicates connector above could be used depending on tolerance in floor to duct dimension.
- ↓↓ - Indicates connector below could be used depending on tolerance in floor to duct dimension.

DUCT CONNECTORS (7990 SERIES)

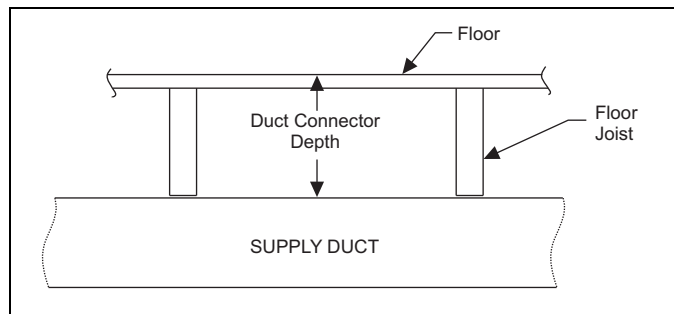

FIGURE 3: Duct Connector Depth (7990 Series)

These duct connectors are for connecting the furnace to an under the floor supply duct system. The furnace may be installed on combustible flooring without a separate sub-base.

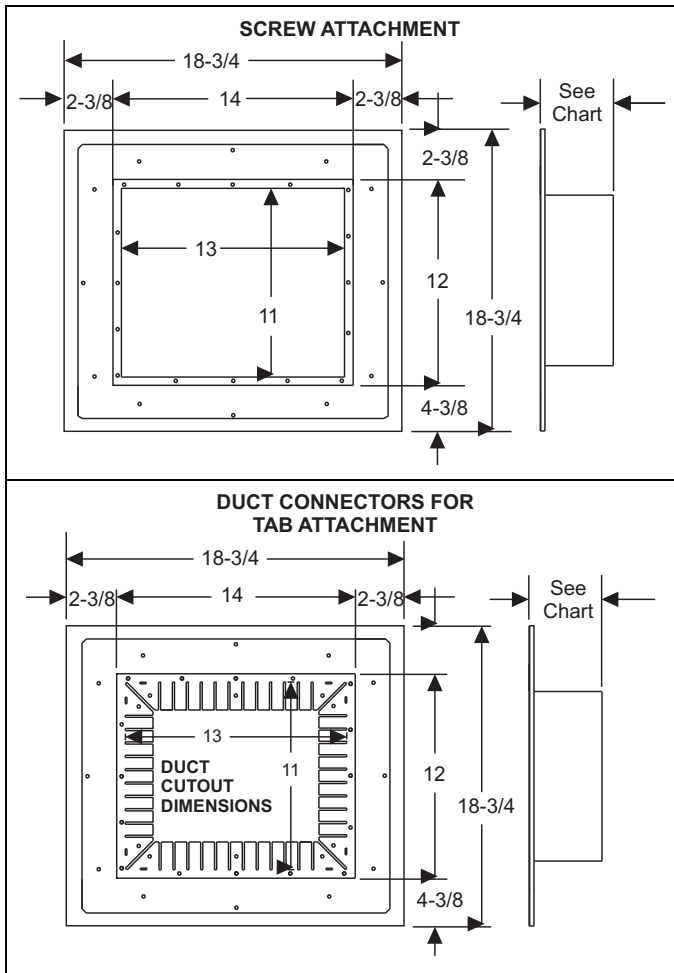

FIGURE 4: Duct Connector Dimensions (7990 Series)

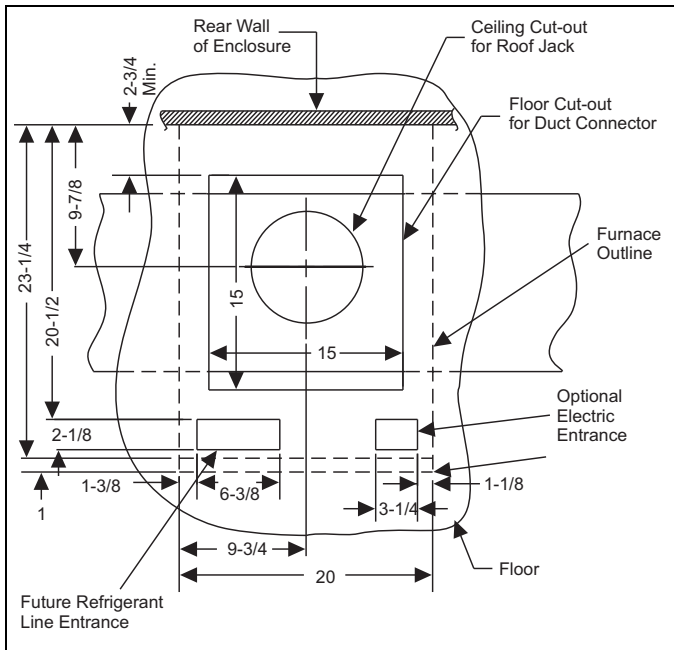

FIGURE 5: Recommended Floor Cut-out (7990 Series)

INSTALLATION OF SCREW ATTACHMENT DUCT CONNECTOR (7990 SERIES)

1. Make floor cut out as shown in Figure 5.
2. Determine the depth of the floor cavity from the surface of the floor to the top of the supply air duct and select the appropriate duct connector from the chart.
3. Place locating bracket (supplied with the duct connector) to the back edge of the floor opening. See Figure 6.

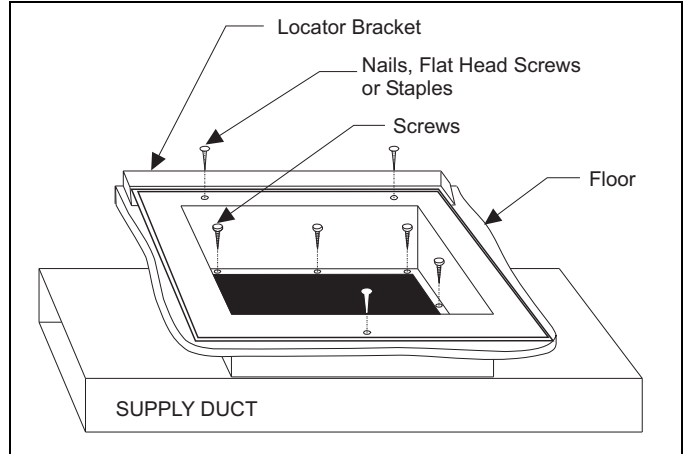

FIGURE 6: Duct Connector Screw Attachment (7990 Series)

4. Apply a water based duct sealant to the 1/2" supply duct attachment flange of the duct connector.
5. Determine which of the four positions the duct connector best centers over the supply duct and insert it through the floor cutout.
6. When properly aligned with the supply duct, secure the duct connector to the floor with nails, flat head screws or staples.
7. Use screws as required to secure duct connector to supply duct.
8. Cut out the opening to the supply duct. If sealant was not used, the installer should tape the mating flanges to provide a good air seal.

NOTE: Duct sealant and tape must be classified as meeting HUD Standard 3280.715, U.L. Standard 181A.

INSTALLATION OF TAB ATTACHMENT DUCT CONNECTOR (7990 SERIES)

1. Make floor cut out as shown in Figure 5.
2. Determine the depth of the floor cavity from the surface of the floor to the top of the supply air duct and select the appropriate duct connector from the chart.
3. Place locating bracket (supplied with the duct connector) to the rear of the floor area for the furnace. See Figure 7.

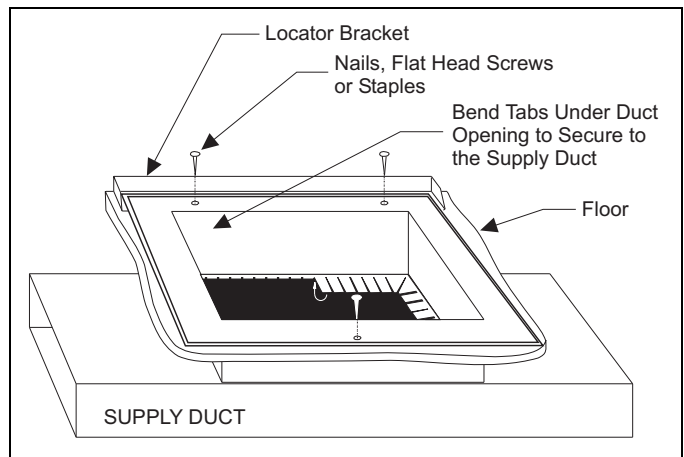

FIGURE 7: Duct Connector Tab Attachment (7990 Series)

4. Determine which of the four positions the duct connector best centers over the supply duct and insert it through the floor cutout.
5. Mark cut-out location on the supply duct and remove the duct connector.
6. Cut out the opening to the supply duct.
7. Bend tabs down through and back up under the supply duct.
8. Secure the duct connector to the floor with nails, flat head screws or staples.

The duct connector is designed for use on ducts down to 12" in width. When using the connector on smaller width ducts, there will not be sufficient clearance to bend the tabs on two sides of the duct connector.

In such cases the tabs may be attached to the sides of the duct by using sheet metal screws or other suitable fasteners. Holes for sheet metal screws are provided in three (3) tabs on each side of the duct connector. If more than 3 tabs need to be used to provide a more secure and air tight connection, the remaining tabs can also be fastened to the duct with screws after drilling the required screw holes.

PARALLEL DUCT SYSTEM

The EB Duct Connector Insert 37323716001 may be used on EB Series Electric Furnaces where the duct system runs parallel to the furnace. See Figure 8. The EB Duct Connector Insert should not be used if the duct system runs perpendicular to the furnace or if the duct system extends only one direction from the furnace.

The Duct Connector Insert cannot be used with 1" and 2" Duct Connectors (7990-6011, 7990-6021, 7990-6211, and 7990-6221).

Follow Accessory Kit Installation Instruction 035-20632-001 provided with the Duct Connector Insert.

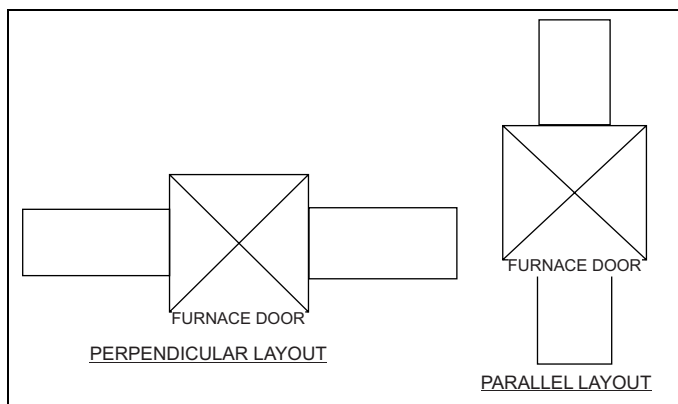

FIGURE 8: Duct System Configuration

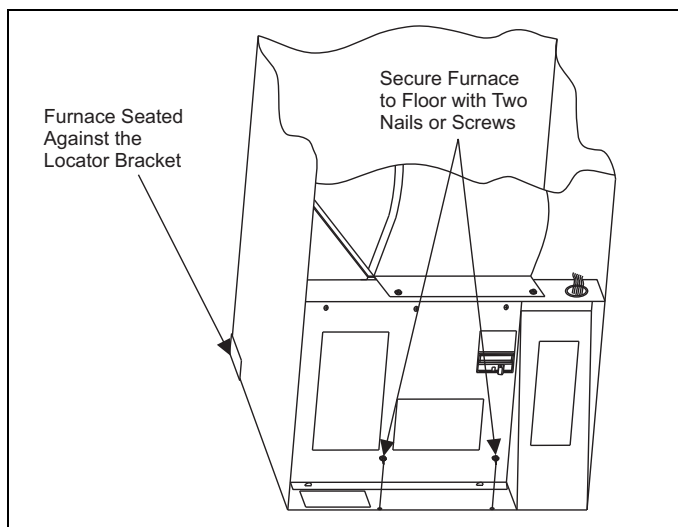

FIGURE 9: Installation of Furnace

INSTALLATION OF THE FURNACE

1. Remove the front panels and set the furnace onto the duct connector. Slide it back until the rear of the unit engages the locator bracket.
2. Secure the front of the furnace with two screws at the mounting holes provided. See Figure 9.
3. Secure the top of the furnace to a structural member using screw through the strap at the top of the furnace. Strap may be moved to any of the holes located along the top back of the furnace. Installer may provide an equivalent method, such as screws through the casing side.

FURNACE CONVERSION TO UPFLOW APPLICATION

Upflow furnace conversion is easily accomplished by following the steps listed below:

Provide adequate clearance for servicing:

1. Before Conversion, locate the furnace conveniently away from wall facing or partitions to permit easy removal and installation of components.
2. Two (2) feet of space must be available in front of furnace for future servicing (blower or element removal, furnace removal, etc.).

3500-5451* Adapter Box and/or 3500-7211* Upflow Flange Plate Kit are needed prior to following steps below:

1. Assemble the 3500-5451 filter box per instructions provided with kit.
2. Remove furnace panel.
3. Remove air filter.
4. Remove strap on the top of the unit, saving the screw and strap for later use.
5. Turn entire unit upside-down, so the filter box is on the floor.
6. Remove two (2) screws that are on the front of the unit at the top. Obtain front panel hanger angle from the upflow kit 3500-7211*. Secure the hanger angle with two (2) screws removed from the furnace casing See Figure 10.

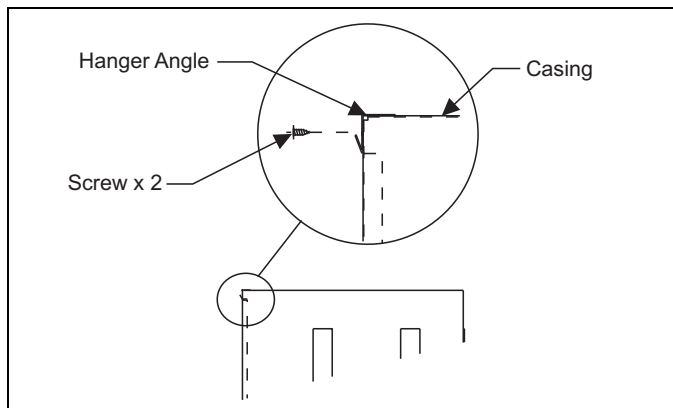

FIGURE 10: Hanger Angle Attachment

7. Attach the strap that was removed in Step 4 to the top, side or back of the furnace.
8. Install the duct flange plate on top of the inverted furnace as shown in Figure 11.
9. If installing a POS, Standard or Deluxe Air Systems, proceed to Step 10. Optional start collar for the Economy POS system shipped with 3500-7211* can be used for blend air flex duct installation. Punch the lineset knockout out and position the start collar over it. Duct connector edge can be pushed under the casing flange and screws provided can be used to capture the other end of duct connector. Secure collar to top of furnace.

10. Flange plate shipped with 3500-7211* is mounted to the furnace with eight (8) screws provided. Two (2) blunt screws are for the holes in the front of the furnace. See Figure 11.
11. If upflow adapter box kit 3500-5451* is not used, then our optional filter bracket is provided with 3500-7211* kit. This filter bracket maybe used to retain filter inside its original location in the furnace.
12. Secure the top of the furnace to a structural member using screws and the strap on top of the furnace. The mobile home manufacturer may provide an equivalent strap, if required, to secure the furnace.
13. If excessive movement is expected, then some blower support is recommended.

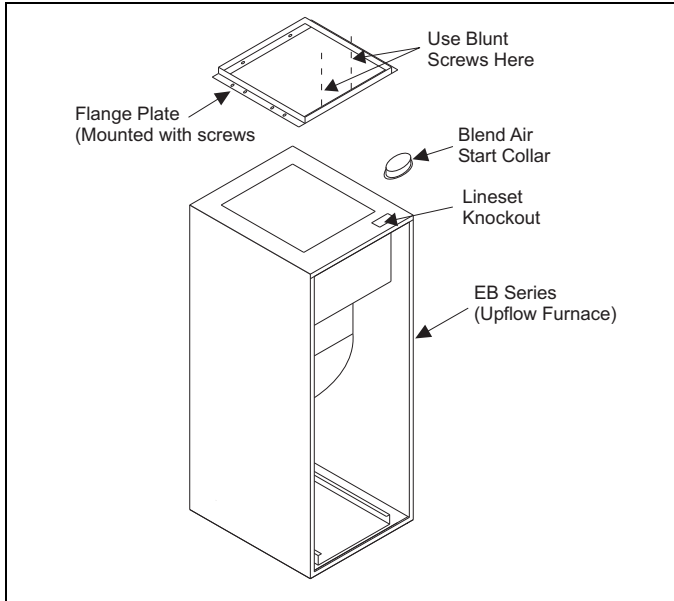

FIGURE 11: Blower Bracket and Duct Flange Attachment

WIRING

Furnace wiring is complete except for the power supply and the thermostat wires. See wiring diagrams (Figures 16-21) for wire and fuse size. See Table 2 for ground wire sizes. Thermostat wires connect through side of furnace and should also be no smaller than 22 gauge. Power wires can enter through the side of the unit or through the auxiliary entrance, located in the bottom of the unit. (See Figure 1). When bringing wiring through the bottom of the furnace, cable connectors must be installed to hold wiring in place and to relieve any strain on the wiring. These connectors will also serve as a seal between the furnace and the floor. Thus, additional sealing is not required.

Refer to the National Electrical Code, Canadian Electrical Code and local codes for wiring material requirements.

NOTE: The furnaces are equipped with either one or two 60 amp circuit breakers. These circuit breakers protect the wiring inside of the furnace in the event of a short circuit. Additionally, these breakers provide a means of disconnecting the power to the unit. The circuit breakers in the furnace are not meant to protect the branch circuit wiring between the furnace and the home's breaker panel. General wire and breaker sizes are shown in Table 2. If sheathed cable is used, refer to National Electrical Code, Canadian Electrical Code and local codes for additional requirements concerning supply circuit wiring. Electrical Data can be found in Table 4.

IMPORTANT: All installation on field wiring must be rated at 60°C or higher.

Models for EB23C, EB20C, EB17C and EB15C may be connected to a single or dual branch circuit.

These units are shipped from the factory set up for dual power supply connections. For single power supply connections, jumper bars (P/N 3500-378P*) are required and are available from the factory. EB12C is factory shipped with jumper bars in place. See Figure 12.

TABLE 2: Wiring Requirements

MODELS	EB23C*		EB20C*		EB17C*		EB15C*		EB12C	EB10C
Single Branch Circuit Service	2 Leads + 1 Ground CKT#1									
Nominal Circuit Load - Amps	94.0		84.0		70.7		64.0		50.7	44.0
Minimum Wire Size (90°C)	#2		#3		#4		#4		#6	#8
Minimum Wire Size (75°C)	#1		#2		#3		#4		#6	#6
Minimum Wire Size (60°C)	#0		#1		#2		#3		#4	#6
Ground Wire Size +	#6		#6		#8		#8		#8	#10
Max. Fuse (or C.B.) - Amps	125		110		90		80		70	60
Dual Branch Circuit Service	CKT #1	CKT #2	CKT #1	CKT #2	CKT #1	CKT #2	CKT #1	CKT #2	NOT APPROVED	
Branch Circuit Load - Amps	47.3	46.7	44.0	40.0	47.3	23.4	44.0	20.1		
Branch Circuit Min. - Amps	59.2	58.4	55.0	50.0	59.2	29.3	55.0	25.2		
Minimum Wire Size (90°C)	#6	#6	#8	#8	#6	#10	#8	#10		
Minimum Wire Size (75°C)	#6	#6	#6	#8	#6	#10	#6	#10		
Minimum Wire Size (60°C)	#4	#4	#6	#6	#4	#10	#6	#10		
Ground Wire Size +	#10	#10	#10	#10	#10	#10	#10	#10		
Max. Fuse (or C.B.) - Amps	60	60	60	50	60	30	60	30		

* Requires Jumper Bars (P/N 3500-378P) - Dual Supply for U.S. Only.

+ Refer to National Electrical Code. Table 250-95 for Non-Sheathed Conductor Ground Wire.

TABLE 3: EB Series Blower Performance

Static Pressure (inches of w.c.)		0.0	0.1	0.2	0.3	0.4	0.5	0.6	0.7	0.8
Low Speed - Heating Speed Models EB10, 12, 15	CFM (STD. Air)	945	936	936	924	915	889	870	813	705
Medium Speed - Heating Speed Models EB17, 20, 23	CFM (STD. Air)	1160	1145	1145	1140	1129	1109	1073	1027	935
Medium High - with A-Coil in place	CFM (STD. Air)	1340	1317	1290	1252	1208	1158	1095	1021	876
High - with A-Coil in place	CFM (STD. Air)	1573	1534	1490	1435	1369	1309	1237	1135	1019

TABLE 4: Electrical Data

MODEL NUMBER			EB23C	EB20C	EB17C	EB15C	EB12C	EB10C
D.O.E. Output	240 VAC 60 Hz. 1 Phase	BTU	77,000	67,000	56,000	51,000	39,000	34,000
		kW	22.6	19.6	16.4	15.0	11.4	10.0
OUTPUT CAPACITY	230 VAC 60 Hz. 1 Phase	BTU	71,000	61,000	52,000	47,000	36,000	31,000
		kW	20.8	17.9	15.2	13.8	10.6	9.1
	220 VAC 60 Hz. 1 Phase	BTU	65,000	57,000	48,000	43,000	33,000	29,000
		kW	19.1	16.7	14.1	12.6	9.7	8.5
Element Capacity @ 240 VAC		kW	21.6	19.2	16.0	14.4	11.2	9.6
		Amps	90.0	80.0	66.7	60.0	46.7	40.0
Motor Amps @ 240 V.			4.0 Maximum					
Circuit Load Amps @ 240 V.		CKT 1	47.3	44.0	47.3	44.0	50.7 ¹	44.0 ¹
		CKT 2	46.7	40.0	23.4	20.0	NA	NA

Casing or cabinet must be permanently grounded in accordance with National Electrical Code or other applicable codes.

1. Approved for Single Branch Circuit Service Only.

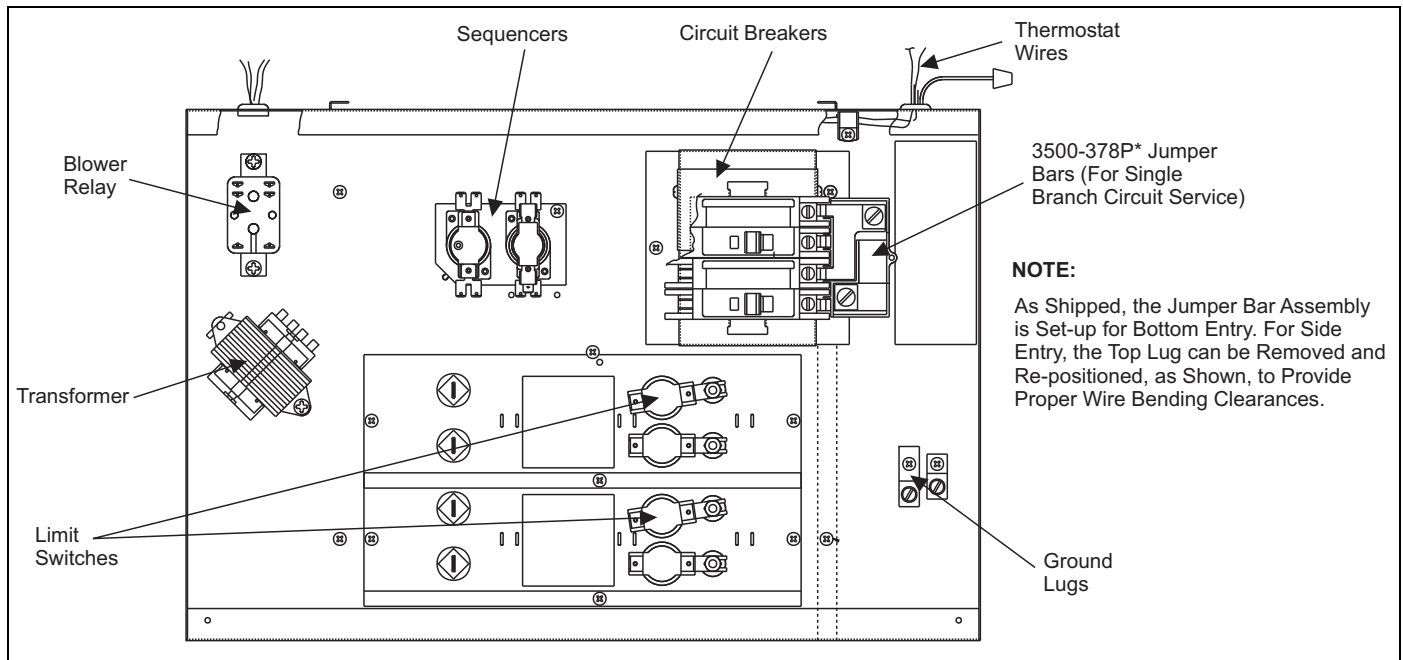

FIGURE 12: Control Box

WARNING

For personal safety be sure to turn the electrical power OFF at the household service box and at the furnace circuit breakers before attempting any service or maintenance operations. Homeowners should never perform any maintenance which requires opening electric box door.

Furnace is equipped with a protective shield over field wiring connection. When field wiring is completed, shield must be replaced to prevent hazard of electrical shock when using furnace disconnect. (See Figure 13.)

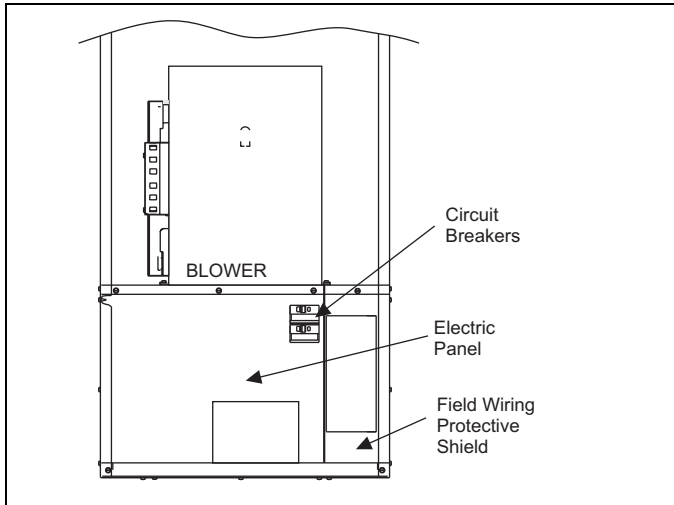

FIGURE 13: Field Wiring Shield

SECTION V: THERMOSTAT INSTALLATION

The adjustable heat anticipator in the thermostat is pre-set at 0.4 Amps. This setting should be checked at the time of installation.

In some cases the thermostat may be a "self-setting" type in which case no amp setting will be found on the thermostat, eliminating the need for any field adjustment.

Thermostat should be located on an inside wall in an open area to more

closely regulate average room air, preferably, where there is air movement back to furnace. Care should be used to locate thermostat away from hot air discharge openings, lights, etc. Locating height of thermostat is important. Thermostat should be located 52" to 66" (132 - 167.6 cm) above the floor. This is sometimes called the comfort zone.

If a condenser with its own Transformer shares a Heat/Cool Thermostat with this furnace, use a thermostat with isolating contacts to prevent interconnection of Class II 24 Volt Systems.

Cycle furnace using the thermostat to make sure it will operate correctly.

Maintenance and operating instructions are in the customer envelope accompanying the furnace. Give the customer envelope to the home owner.

CAUTION

When using separate thermostats, a thermostat interlock system must be provided to prevent simultaneous operation of the furnace and air conditioner. Simultaneous operation can result in coach overheating, equipment damage and energy waste. (See Figures 14 and 15.)

Do not connect Yellow wire to thermostat until an outdoor unit is installed.

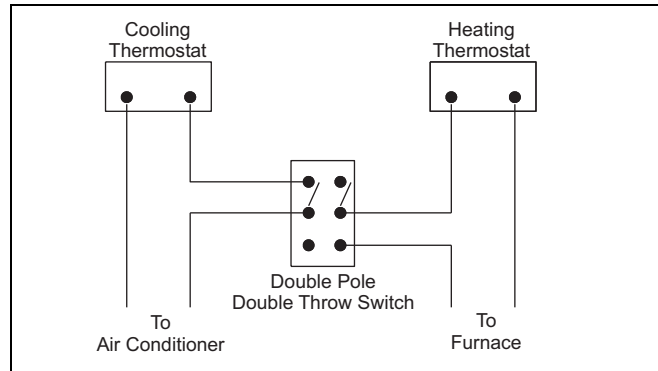
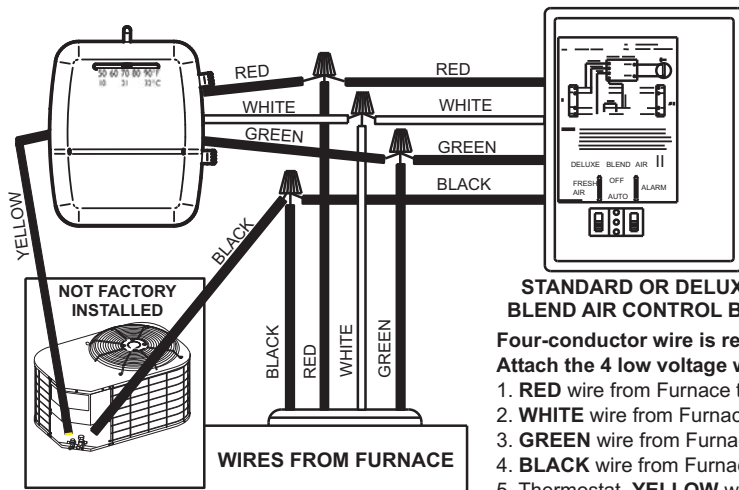

FIGURE 14: Thermostat Wiring

The EB*C* Furnaces are A/C ready. All furnaces installations should include a minimum of four conductor thermostat wiring to accommodate future air conditioning installations.

THERMOSTAT WIRING SCHEMATIC FOR: BLEND AIR AND FURNACE



- Four-conductor wire is required for thermostat connection. Attach the 4 low voltage wires extending from the control box as follows:
1. RED wire from Furnace to thermostat RED wire.
 2. WHITE wire from Furnace to thermostat WHITE wire.
 3. GREEN wire from Furnace to thermostat GREEN wire.
 4. BLACK wire from Furnace to condensing unit contactor.
 5. Thermostat YELLOW wire to condensing unit contactor.

FIGURE 15: Thermostat Wiring

SECTION VI: OPTIONAL AIR CONDITIONING ACCESSORIES

WARNING

Failure to install this insulation and coil shelf kit could result in damage to equipment and/or personal injury. Liability and warranty from the manufacturer could also be void.

This furnace is already equipped with a blower and control system to add-on air conditioning and heat pump. Insulation and coil shelf kit (3500-8941* for downflow or 3500-8961* for upflow) must be installed when adding on such remote air conditioning systems.

HIGH PERFORMANCE BLOWER ACCESSORY PACK- AGE

CAUTION

All areas around the line sets, drain hoses and other openings in the coil shelf should be sealed air tight. Use some moldable compound or caulking to seal the area. Failure to do so may result in loss of performance and premature compressor failure.

All EB furnaces are equipped with a blower and control system to add-on air conditioning and heat pumps to specified sizes. If the requirement is to achieve more air flow or cooling than specified, then the blower inside the furnace has to be replaced with an accessory blower package 3500-7901*. This accessory blower package would deliver air conditioning up to 5-tons, and heat pump up to 4-tons. Accessory package (3500-7901*) includes blower, insulation, coil shelf, trap, clamps, etc. Please refer to the installation instructions packed with the accessory package for more information.

SECTION VII: WIRING DIAGRAMS

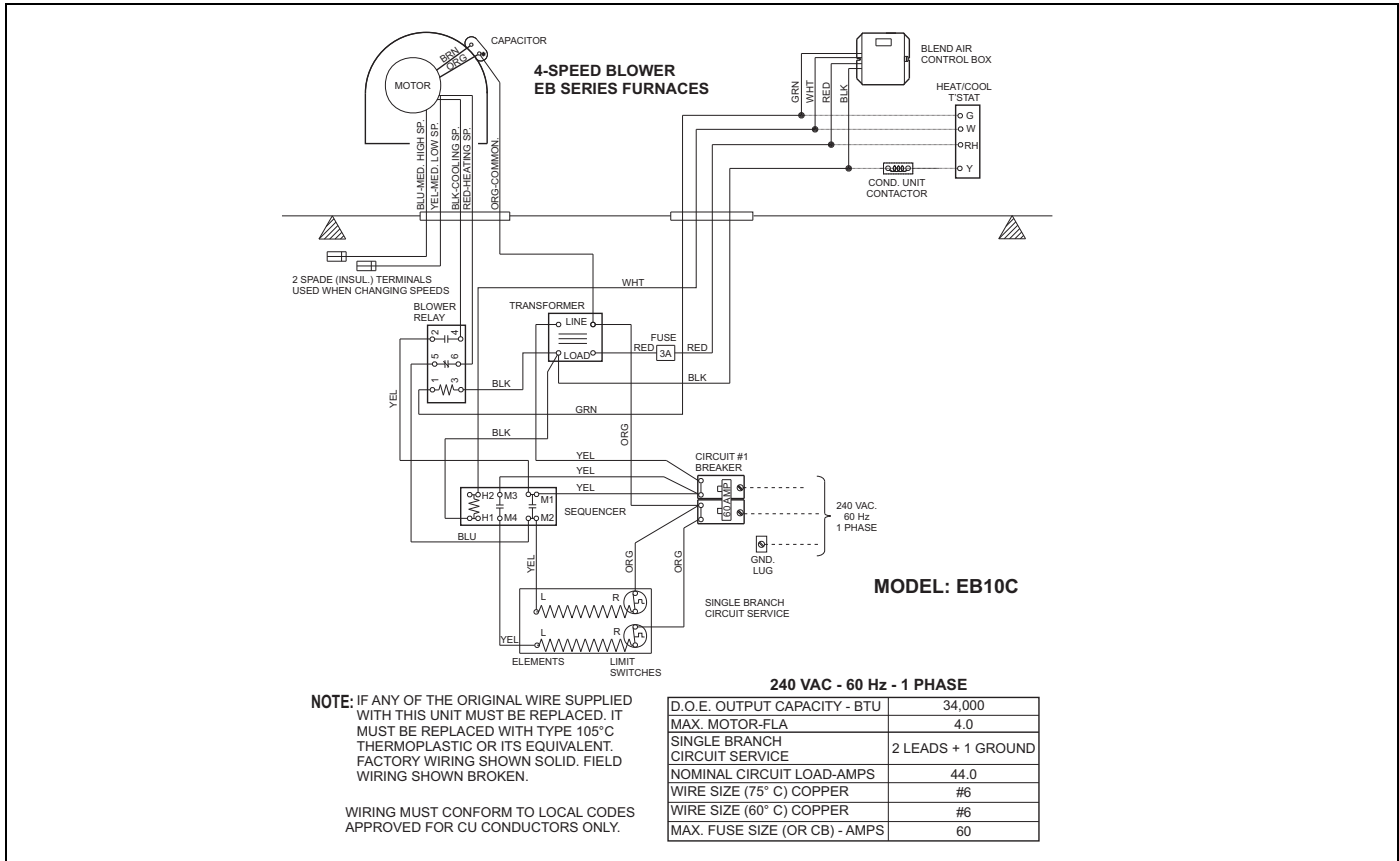

FIGURE 16: EB10C Wiring Diagram

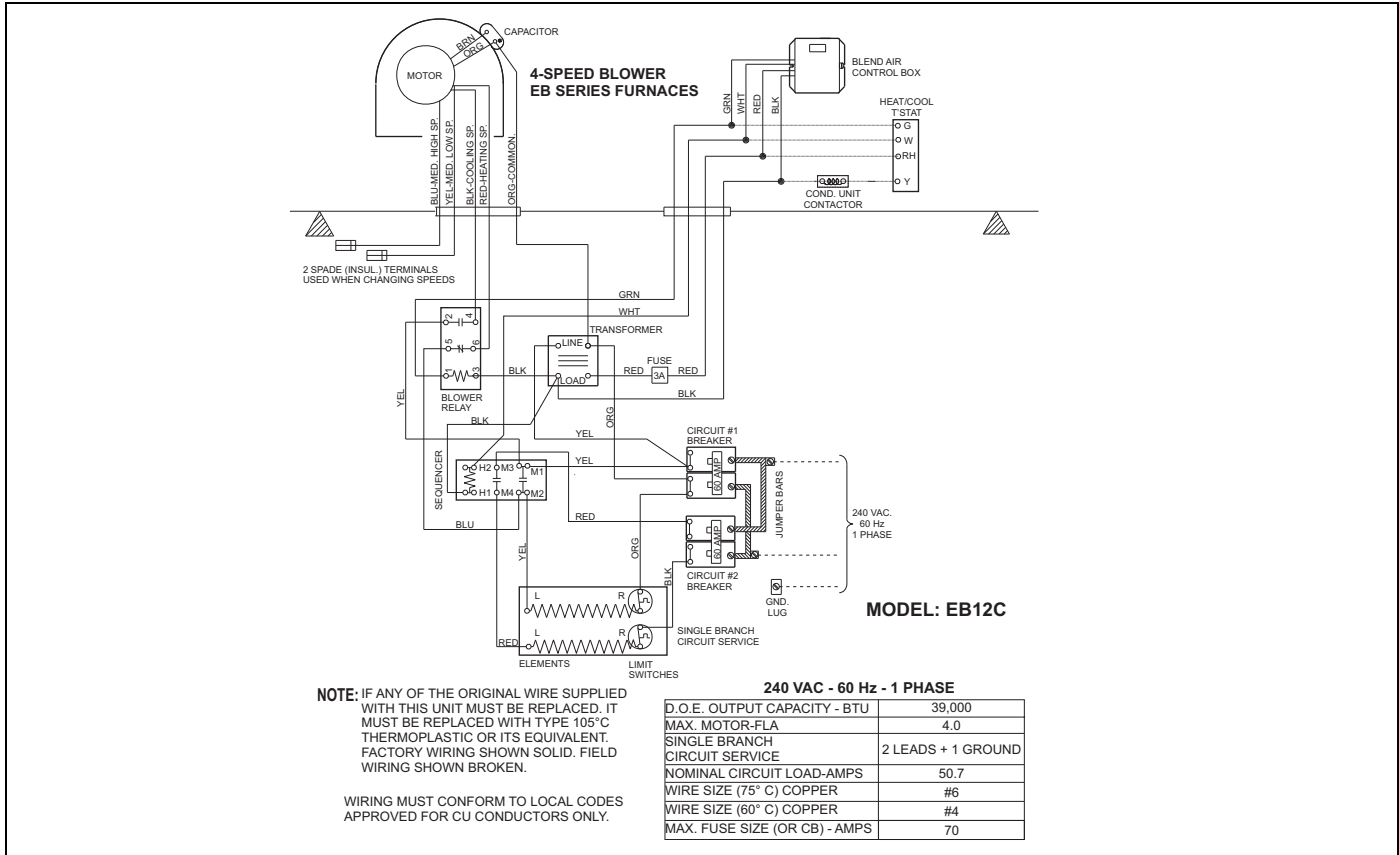

FIGURE 17: EB12C Wiring Diagram

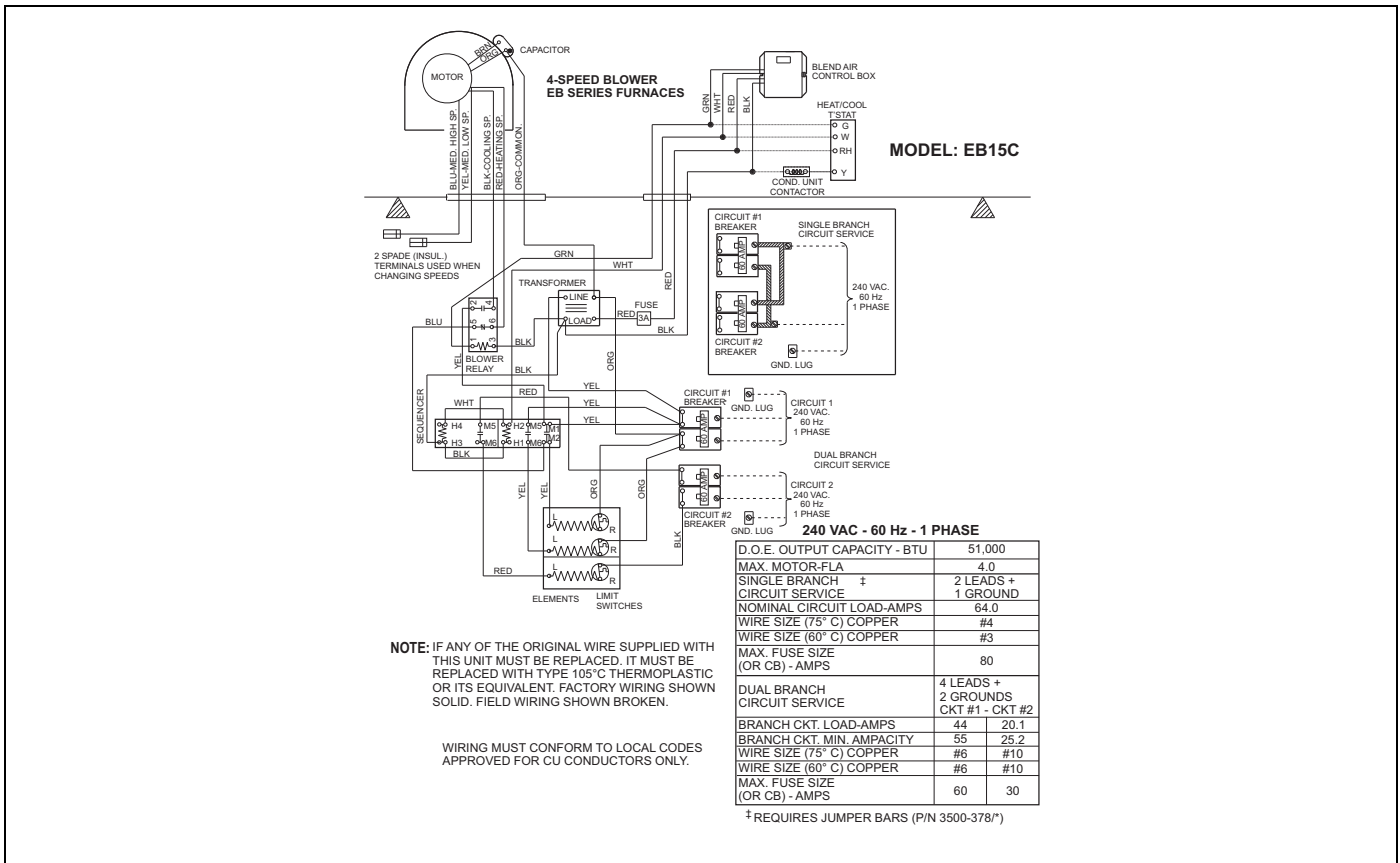

FIGURE 18: EB15C Wiring Diagram

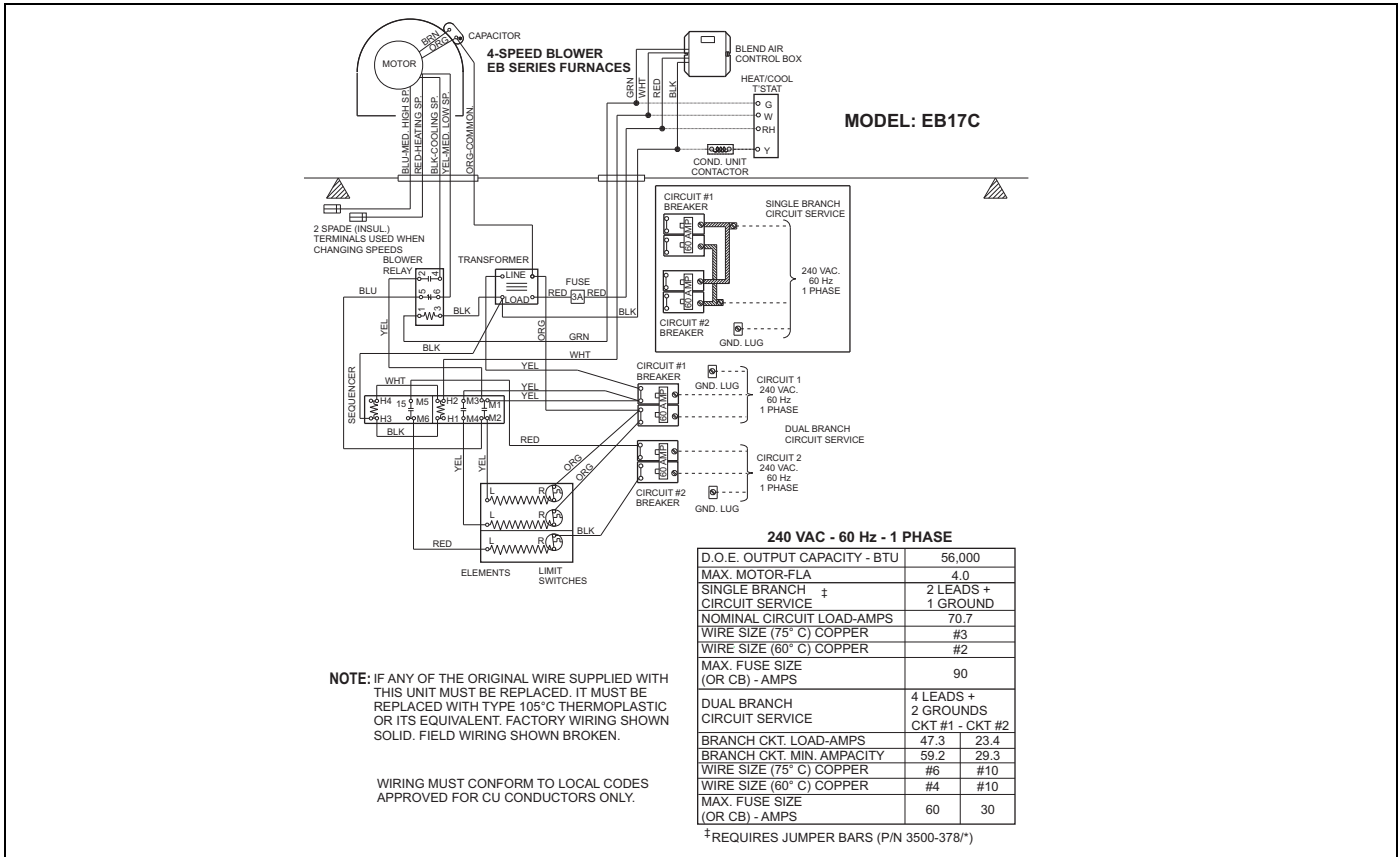

FIGURE 19: EB17C Wiring Diagram

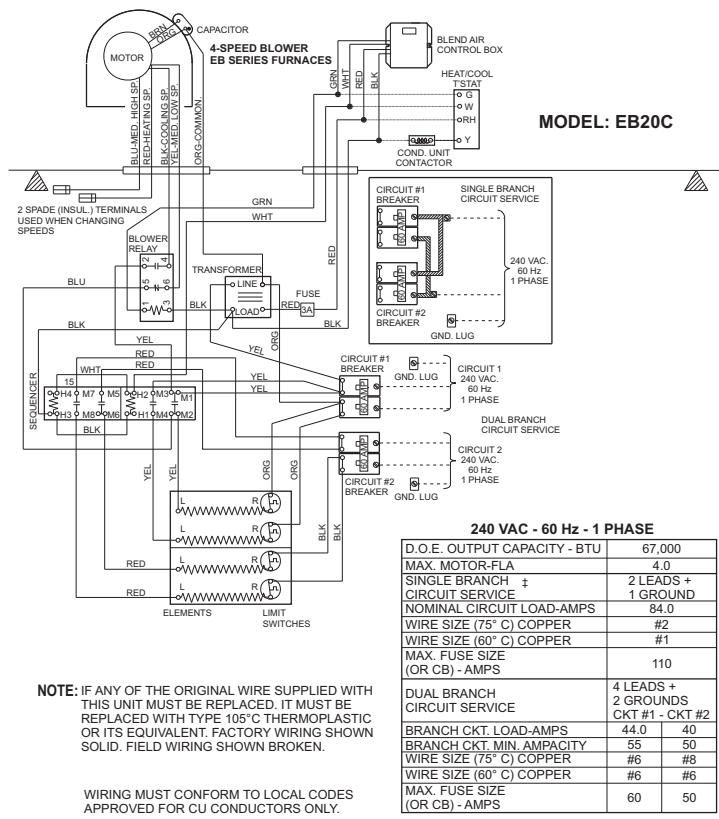

FIGURE 20: EB20C Wiring Diagram

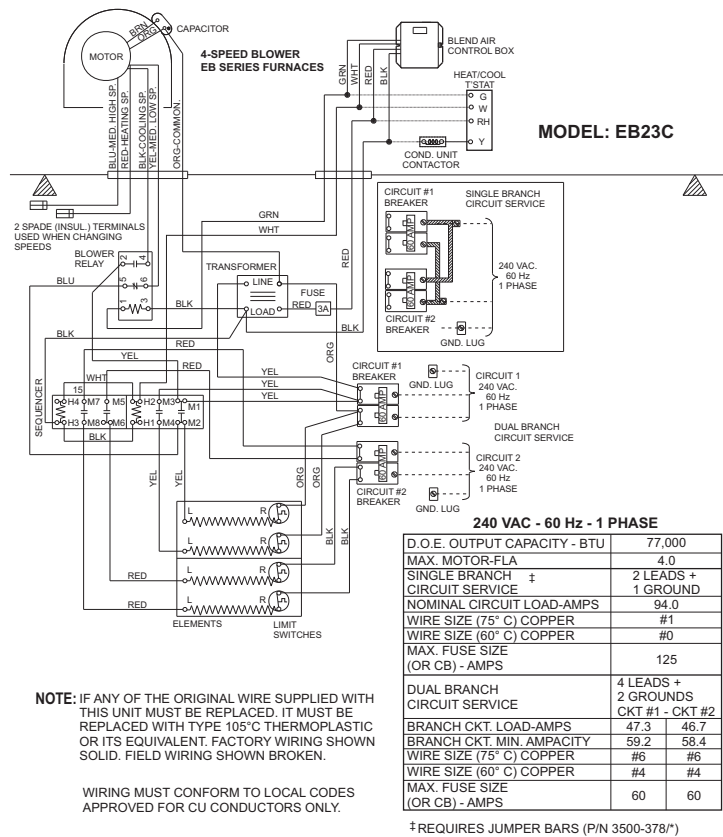

FIGURE 21: EB23C Wiring Diagram