



MODEL **97406**
Combustion air
intake system

Instruction manual

Applies to air intake assemblies:

97406 on EZ-1 burners

97406C on EZ-LF burners

97406A or 97406B on EZ-Gas burners

Installation also requires a Field Controls
Model CAS-1 air hood and vacuum relief
valve, supplied by installer.

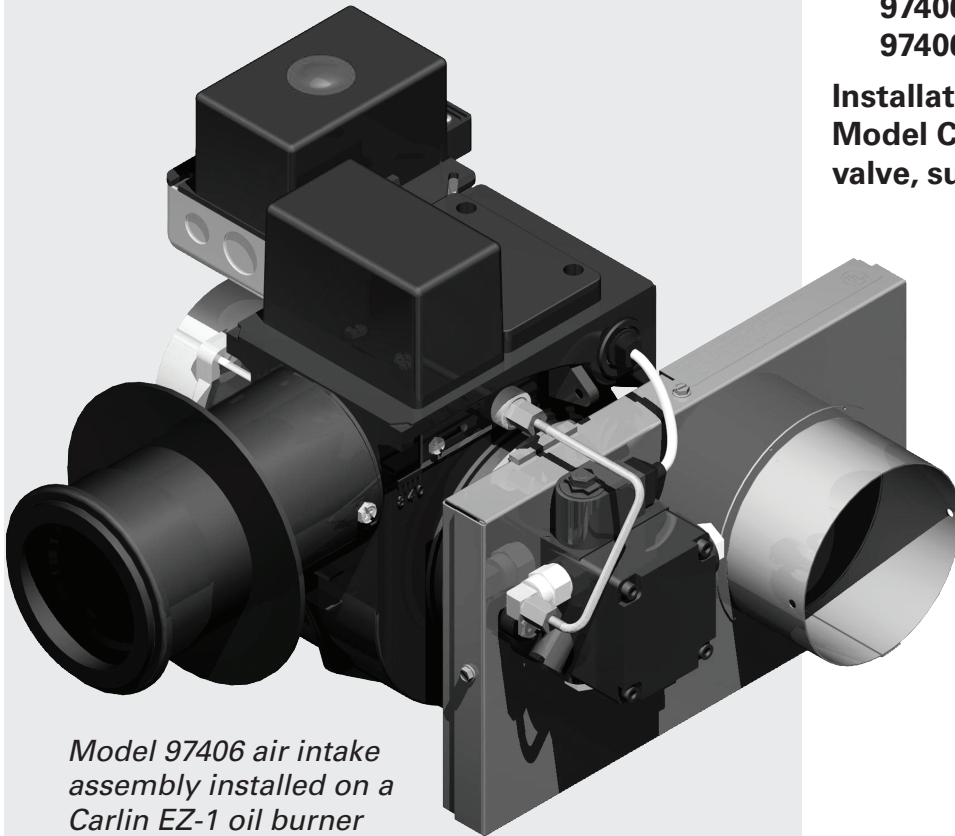

Model 97406 air intake
assembly installed on a
Carlin EZ-1 oil burner

WARNING

Connecting an outside air supply directly to the burner, using the Carlin air intake system, requires the following:

- Use only a Carlin 97406 for an EZ-1 oil burner, 97406C for an EZ-LF oil burner, or a 97406A (horizontal) or 97406B (vertical) air boot for an EZ-Gas burner.
- Obtain and install only a Field Controls Model CAS-1, with 4" inlet air hood and 4" vacuum relief valve.
- The burner and all components must be installed by a qualified service technician.
- The burner must be started and set up (using combustion test instruments) according to the burner and appliance manuals and this air intake system manual.
- Because inlet air temperature affects how much air enters the burner, the installer must use the combustion set-up table in this manual to compensate for the air temperature at the time of combustion adjustment.

WARNING

Installer/servicer — Except where specifically stated otherwise, this manual must be used only by a **qualified service technician**. (In the state of Massachusetts, this product must be installed by a licensed Plumber or Gas Fitter.) Failure to comply with this or other requirements in this manual could result in severe personal injury, death or substantial property damage.

Code compliance — Follow all applicable state and local codes regarding installation of the burner, appliance, venting and air supply.

© Copyright 2007 — Carlin Combustion Technology, Inc.

Carlin Combustion Technology, Inc.

70 Maple Street
Ph 413-525-7700

East Longmeadow, MA 01028
Fx 413-525-8306

TECH SUPPORT 800-989-2275

carlincombustion.com

1. Assemble air intake assembly to the burner (EZ-1 or EZ-LF oil burner)

Assembly of 97406 to an EZ-1 or 97406C to an EZ-LF burner

1. Disconnect oil lines as shown above. For burners with integral oil valve fuel units, just disconnect the oil line fitting at the knurled nut as shown. For burners with separate oil valves, disconnect both fuel unit oil lines as shown in Figure 1. Bend the oil lines to fit the new configuration.
2. Remove the two bolts that secure the fuel unit to the burner housing. Then move the fuel unit out of the way (integral oil valve type) or remove the fuel unit as shown in Figure 1 (separate oil valve type).
3. Remove the burner air shutter and air band and discard them.
4. Assemble the air intake assembly to the burner as shown in Figure 1.
5. Reattach the fuel unit to the burner housing with the two bolts removed in step 2.
6. Integral oil valve fuel unit type — Reattach the oil valve at the knurled nut. Separate oil valve type — Bend the oil lines to fit and reattach both lines to the fuel unit and burner as shown in Figure 1.

Where appliance instructions differ from this manual, follow the appliance instructions.

Figure 1 Assembling an air intake assembly to a Carlin EZ-1 or EZ-LF oil burner

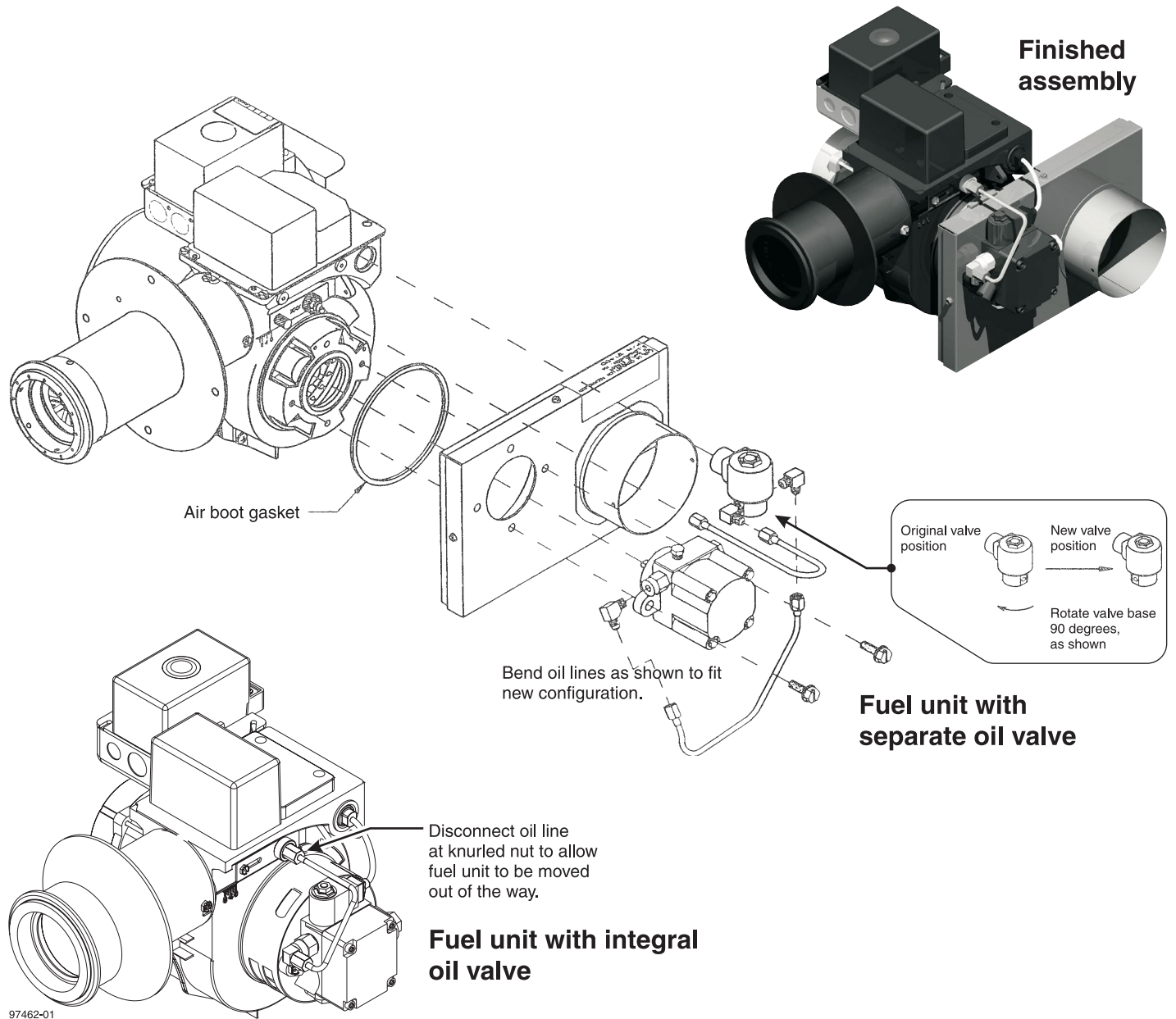

1. Assemble air intake assembly to the burner (EZ-Gas gas burner)

Assembly of 97406A or B to an EZ-Gas burner

1. Remove the two bolts that secure the airflow switch bracket to the burner housing. Move the airflow switch out of the way.
2. Then remove and discard the air band. Install the air intake assembly and gaskets as shown.
3. Reattach the airflow switch bracket to the burner housing with the two bolts. Make sure the airflow sensing lines are inserted into the holes in the burner housing.

Where appliance instructions differ from this manual, follow the appliance instructions.

Figure 2 Assembling a 97406A or B air intake assembly to a Carlin EZ-Gas gas burner

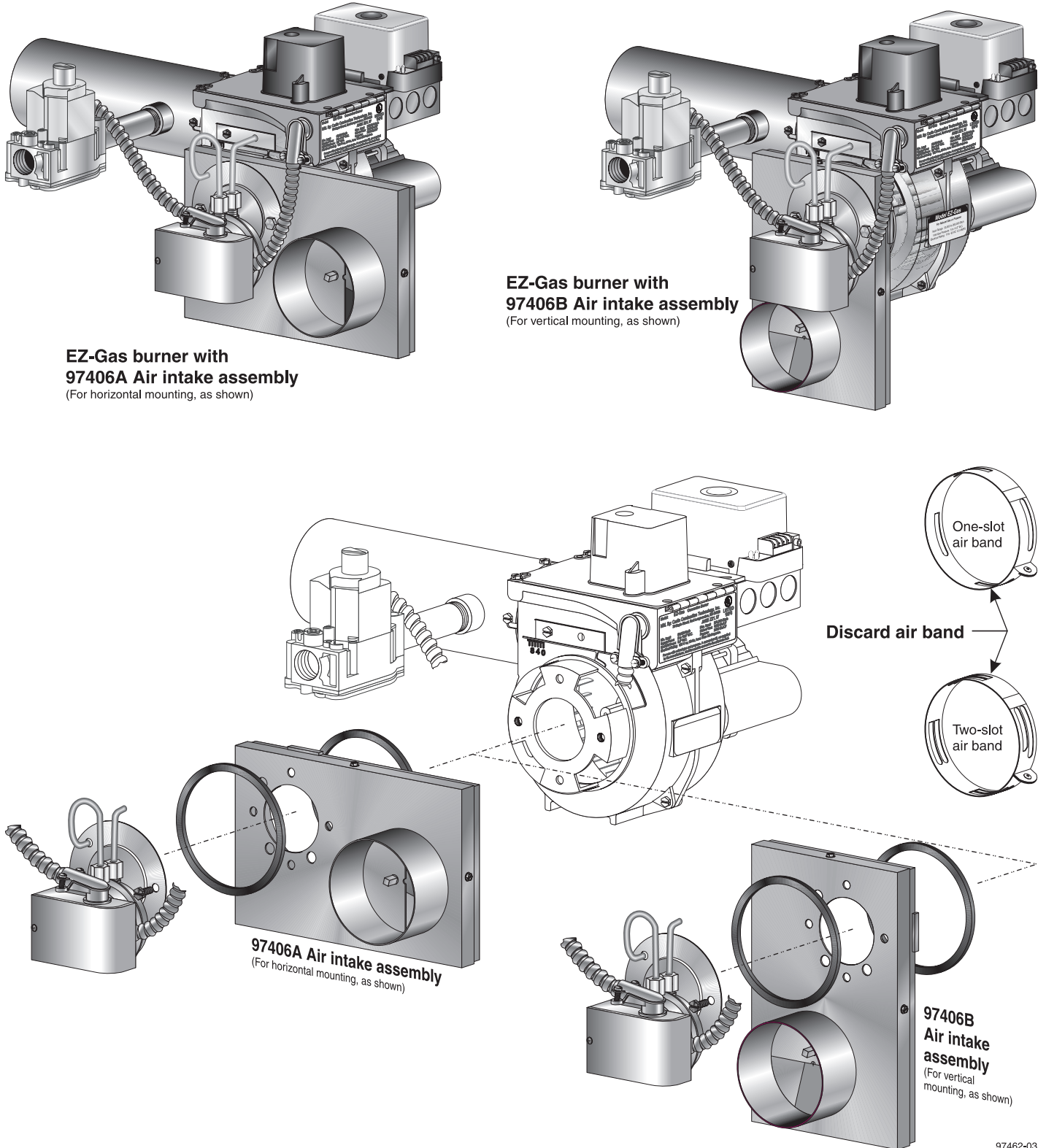

2. Install combustion air piping

Air piping components

Field CAS-1 combustion air system

The installer must obtain a Field Controls Model CAS-1 inlet air system. The vent piping must include the vacuum relief valve (4" VRV) and intake air hood (4" IAH Hood) provided in the Model CAS-1 kit. (See Figure 3.)

Material

Use only corrosion-resistant metal pipe 4 inches in diameter.

Joints

Air pipe joints must be sealed with duct tape or silicone adhesive sealant.

Supports

Provide piping supports located to prevent pipe sagging and to support the air piping independently from the burner.

Maximum length

When using smooth metal pipe, the maximum allowable length of air piping is 30 feet with two or less elbows. Each additional elbow reduces the maximum length of air piping by 7 feet. See the following table.

Number of elbows in air piping	Maximum total air pipe length
2	30
3	23
4	16
5	9

Insulation

Cold inlet air can cause condensation to form on the outside of the air piping. For installations where the inlet air temperature can be -10°F or lower, insulate at least the first 10 feet of air pipe (beginning at the air pipe intake air hood location).

Component installation

Field Controls vacuum relief valve

1. Install the VRV tee in the air piping as shown in Figure 3. Adjust the tee so the opening for the gate is plumb.
2. Install the VRV balance weight on the gate as shown in Figure 3, bottom left.
3. Mount the gate assembly in the VRV tee. Level across the gate pivot points as shown in Figure 3, bottom right.

Field Controls intake air hood

Air hood location – air hood must be:

1. Always mounted with the intake pointed down.

Figure 3 Air piping components

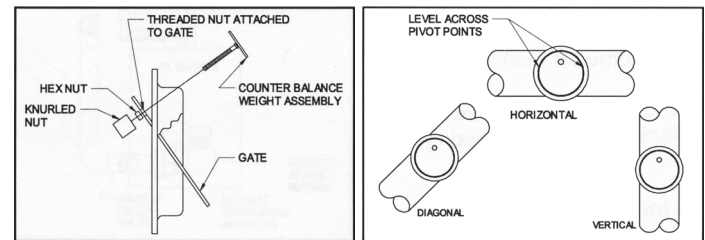
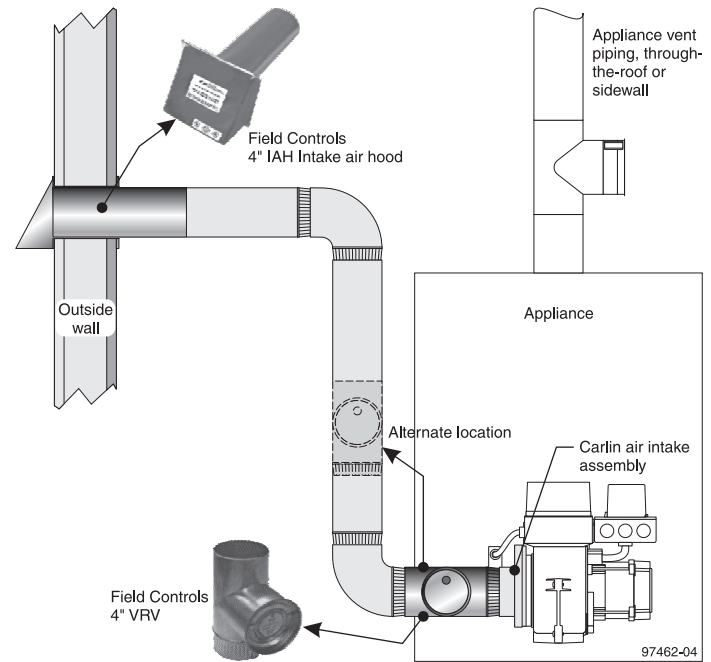

2. At least 12 inches above grade (and at least 12 inches above the highest possible snow line).
3. No closer than 12 inches in any direction to the appliance vent outlet if sidewall vented.

Air hood installation

1. Cut a 4¼"-diameter hole through the sidewall of the building.
2. Slide the inlet air hood pipe through the opening.
3. Seal the mounting plate with silicone adhesive sealant.
4. Secure the air hood assembly to the wall with appropriate fasteners.

Vent pipe installation

1. Secure all joints with screws. Seal all joints using silicone sealant or duct tape.
2. Secure all air piping so the weight is carried completely by the supports.
3. Do not exceed the maximum length given in this manual.
4. Insulate the air pipe if inlet air temperature can be -10°F or colder, or if there is a likelihood of condensation on the vent pipe for any reason.

Where appliance instructions differ from this manual, follow the appliance instructions.

1. Burner/appliance operation

Field Controls vacuum relief valve

The vacuum relief valve should open **temporarily** to allow the burner to use inside air if the air intake piping develops a negative pressure. Negative pressure can occur due to blockage or icing of the air intake or to wind effects on the building. The vacuum relief valve should only open occasionally, and should not remain open for long periods.

WARNING **Vacuum relief valve operation** — For installations where the appliance space may not be able to provide sufficient air for sustained operation using inside air, instruct the building owner to check the vacuum relief valve periodically.

- If the vacuum relief valve remains open for sustained periods, the owner should check the air inlet hood to see if it is obstructed. He should clear any obstructions and check to see if the problem persists.
- If the air inlet hood is not obstructed, or if removing obstructions does not solve the problem, the owner must contact the burner technician immediately to diagnose and correct the reasons for negative pressure in the air piping.
- Failure to follow these guidelines could result in severe personal injury or death.

Adjust the burner using test instruments

After installing the Carlin air intake system and air piping, you must adjust the burner air settings as directed below.

WARNING **The burner air setting must be adjusted** — Adjust the Carlin air intake boot damper to starting setting given in the burner (or appliance) manual. Then follow the burner instruction manual procedure to start the burner and set combustion, using combustion test instruments.

EXCEPTION to burner manual combustion settings: Because the inlet air temperature will vary during the year, you must set the CO₂ (O₂) at different values for different inlet air temperatures. Adjust the burner, following the burner manual, to achieve the CO₂ (O₂) values given in Table 1 or Table 2. Make sure to apply the oil values for oil burners (Table 1) and the gas values for gas burners (Table 2). When final adjustments are complete, the CO₂ or O₂ values must be between the min and max values given in Table 1 or Table 2. Smoke number, as stated in the burner manual, must be zero for oil firing.

Failure to properly adjust the burner/appliance following the burner/appliance manuals and the guidelines in this manual could result in severe personal injury, death or substantial property damage.

Table 1 EZ-1 oil burner combustion air settings

Inlet air temperature during setup	CO ₂ Max and O ₂ Min at setup			
	#2 Fuel oil			
	CO ₂ min	CO ₂ max	O ₂ max	O ₂ min
-20 °F to 0 °F	8.8 %	10.6 %	8.9 %	6.4 %
5 °F to 30 °F	9.9 %	11.9 %	7.4 %	4.7 %
35 °F to 60 °F	10.5 %	12.5 %	6.6 %	3.9 %
65 °F or higher	11.0 %	13.2 %	5.9 %	2.9 %

Table 2 EZ-Gas gas burner combustion air settings

Inlet air temperature during setup	CO ₂ Max and O ₂ Min at setup			
	Natural gas			
	CO ₂ min	CO ₂ max	O ₂ max	O ₂ min
-20 °F to 0 °F	7.0 %	8.3 %	8.8 %	6.0 %
5 °F to 30 °F	7.5 %	9.4 %	7.9 %	4.8 %
35 °F to 60 °F	8.0 %	9.9 %	7.0 %	3.6 %
65 °F or higher	8.5 %	10.4 %	6.0 %	3.0 %

Inlet air temperature during setup	CO ₂ Max and O ₂ Min at setup			
	Propane gas			
	CO ₂ min	CO ₂ max	O ₂ max	O ₂ min
-20 °F to 0 °F	7.5 %	9.4 %	8.7 %	5.8 %
5 °F to 30 °F	8.0 %	10.6 %	8.0 %	4.6 %
35 °F to 60 °F	8.5 %	11.2 %	7.3 %	3.5 %
65 °F or higher	9.5 %	11.8 %	6.0 %	2.9 %

Model 97406 Combustion air intake system – Instruction manual

Where appliance instructions differ from this manual, follow the appliance instructions.