

INSTALLATION, OPERATING AND SERVICE INSTRUCTIONS FOR

V11 SERIES

COMMERCIAL CAST IRON BOILER



For service or repairs to boiler, call your heating contractor. When seeking information on boiler, provide Boiler Model Number and Serial Number as shown on Rating Label.

Boiler Model Number _V11_ _ _	Boiler Serial Number 64_ _ _ _ _	Installation Date
Heating Contractor		Type Firing
Address		Phone Number



www.burnhamcommercialcastiron.com

IMPORTANT INFORMATION - READ CAREFULLY

All boilers must be installed in accordance with National, State and Local Plumbing, Heating and Electrical Codes and the regulations of the serving utilities. These Codes and Regulations may differ from this instruction manual. Authorities having jurisdiction should be consulted before installations are made.

In all cases, reference should be made to the following Standards:

USA BOILERS

- A. Current Edition of American National Standard ANSI/NFPA 31, "Installation of Oil Burning Equipment", for recommended installation practices.
- B. Current Edition of National Fuel Gas Code, NFPA 54/ANSI Z223.1.
- C. Current Edition of American National Standard ANSI/NFPA 211, "Chimneys, Fireplaces, Vents, and Solid Fuel Burning Appliances", For Venting requirements.
- D. Current Edition of American Society of Mechanical Engineers ASME CSD-1, "Controls and Safety Devices for Automatically Fired Boilers", for assembly and operations of controls and safety devices.
- E. All wiring on boilers installed in the USA shall be made in accordance with the National Electrical Code and/or Local Regulations.

CANADIAN BOILERS

- A. Current Edition of Canadian Standards Association CSA B139, "Installation Code for Oil Burning Equipment", for recommended Installation Practices.
- B. The equipment shall be installed in accordance with the current Installation Code for Gas Burning Appliances and Equipment, CSA B149, and applicable Provincial Regulations for the class; which should be carefully followed in all cases.
Authorities having jurisdiction should be consulted before installations are made.
- C. All wiring on boilers installed in Canada shall be made in accordance with the Canadian Electrical Code and/or Local Regulations.

DANGER

Indicates an imminently hazardous situation which, if not avoided, will result in death, serious injury or substantial property damage.

CAUTION

Indicates a potentially hazardous situation which, if not avoided, may result in moderate or minor injury or property damage.

WARNING

Indicates a potentially hazardous situation which, if not avoided, could result in death, serious injury or substantial property damage.

NOTICE

Indicates special instructions on installation, operation, or maintenance which are important but not related to personal injury hazards.

NOTICE

This boiler has a limited warranty, a copy of which is printed on the back of this manual. It is the responsibility of the installing contractor to see that all controls are correctly installed and are operating properly when the installation is complete. The warranty for this boiler is valid only if the boiler has been installed, maintained and operated in accordance with these instructions.

DANGER

DO NOT store or use gasoline or other flammable vapors or liquids in the vicinity of this or any other appliance.

WARNING

Improper installation, adjustment, alteration, service or maintenance can cause property damage, personal injury or loss of life. Failure to follow all instructions in the proper order can cause personal injury or death. Read and understand all instructions, including all those contained in component manufacturers manuals which are provided with the appliance before installing, starting-up, operating, maintaining or servicing this appliance. Keep this manual and literature in legible condition and posted near appliance for reference by owner and service technician.

This boiler requires regular maintenance and service to operate safely. Follow the instructions contained in this manual. Installation, maintenance, and service must be performed only by an experienced, skilled and knowledgeable installer or service agency. All heating systems should be designed by competent contractors and only persons knowledgeable in the layout and installation of hydronic heating systems should attempt installation of any boiler. It is the responsibility of the installing contractor to see that all controls are correctly installed and are operating properly when the installation is completed. Installation is not complete unless a pressure relief valve is installed into the specified tapping located at the rear of appliance - See Section III of this manual for details.

This boiler is suitable for installation on combustible flooring. Do not install boiler on carpeting. Do not operate on floors where heat affected material is below.

Do not tamper with or alter the boiler or controls. Retain your contractor or a competent serviceman to assure that the unit is properly adjusted and maintained.

Clean boiler at least once a year - preferably at the start of the heating season to remove soot and scale.

The inside of combustion chamber should also be cleaned and inspected at the same time.

Have Burner and Controls must be checked at least once a year or as may be necessitated.

Do not operate unit with jumpered or absent controls or safety devices.

Do not operate unit if any control, switch, component, or device has been subject to water.

Return water cannot be lower than 135°F for prolonged periods of time. Operation under these conditions will result in sustained condensing within the combustion chamber and potentially reduce boiler longevity. In addition, the return water cannot be introduced into the boiler if it is more than 40°F less than the idle boiler temperature. Continued operation under these conditions may result in premature boiler failure through thermal shock.

Example: A boiler that has been idle for some time since the last heat demand cycle may have its boiler water temperature reduced to 150°F. The return temperature from the next zone activation cannot be less than 110°F.

If the above conditions exist, an RTC (or similar type of control system) system must be installed to protect the boiler from sustained condensing operation and thermal shock. See separate RTC Manual, P/N 8146382.

WARNING

Appliance materials of construction, products of combustion and the fuel contain alumina, silica, heavy metals, carbon monoxide, nitrogen oxides, aldehydes and/or other toxic or harmful substances which can cause death or serious injury and which are known to the state of California to cause cancer, birth defects and other reproductive harm. Always use proper safety clothing, respirators and equipment when servicing or working nearby the appliance.

This boiler contains very hot water under high pressures. Do not unscrew any pipe fittings nor attempt to disconnect any components of this boiler without positively assuring the water is cool and has no pressure. Always wear protective clothing and equipment when installing, starting up or servicing this boiler to prevent scald injuries. Do not rely on the pressure and temperature gauges to determine the temperature and pressure of the boiler. This boiler contains components which become very hot when the boiler is operating. Do not touch any components unless they are cool.

This appliance must be properly vented and connected to an approved vent system in good condition. Do not operate boiler with the absence of an approved vent system.

This boiler needs fresh air for safe operation and must be installed so there are provisions for adequate combustion and ventilation air.

The interior of the venting and air intake systems must be inspected and cleaned before the start of the heating season and should be inspected periodically throughout the heating season for any obstructions. Clean and unobstructed venting and air intake systems are necessary to allow noxious fumes that could cause injury or loss of life to vent safely and will contribute toward maintaining the boiler's efficiency.

This boiler is supplied with controls which may cause the boiler to shut down and not re-start without service. If damage due to frozen pipes is a possibility, the heating system should not be left unattended in cold weather; or appropriate safeguards and alarms should be installed on the heating system to prevent damage if the boiler is inoperative.

This boiler is designed to burn No. 2 fuel oil, natural and/or LP gas only. Do not use gasoline, crankcase drainings, or any oil containing gasoline. Never burn garbage or paper in this boiler. Do not convert to any solid fuel (i.e. wood, coal). All flammable debris, rags, paper, wood scraps, etc., should be kept clear of the boiler at all times. Keep the boiler area clean and free of fire hazards.

Always keep the oil supply valve shut off if the burner is shut down for an extended period of time.

Probe and float type low water cutoff devices require annual inspection and maintenance. Refer to instructions in Section V, Paragraph C for inspection and cleaning instructions.

NOTICE

All V11 Series cast iron boilers are designed, built, marked and tested in accordance with the ASME Boiler and Pressure Vessel Code, Section IV, Heating Boilers. An ASME Data Label is factory applied to each V11 jacket, which indicates the boiler Maximum Allowable Working Pressure (MAWP). Each cast iron section is permanently marked with the MAWP listed on the boiler's ASME Data Label. Those values for the V11 are as follows:

MAWP, Steam - 15 psi

MAWP, Water (USA) - 80 psi

MAWP, Water (Canada) - 50 psi

It is common and acceptable practice to install these boilers in lower pressure systems, below the boiler MAWP. Therefore, Burnham offers safety relief valves set at or below the MAWP of the boiler. See Table 1 for available safety relief valve set pressures.

TABLE OF CONTENTS

SECTION I - GENERAL INFORMATION

Dimensional Information	8
Ratings/Data	9
Locating the Unit	10
Air Supply/Venting.....	11

SECTION II - CAST IRON BLOCK ASSEMBLY (Knockdown Only)

Assembly of Sections, Manual Draw-up	14
Assembly of Sections, Hydraulic Draw-up	19
Hydrostatic Test	20

SECTION III - INSTALLATION INSTRUCTIONS

Knockdown

Canopy	23
Flue Cover Plates	25
Rear Observation Port Cover.....	25
Inspect All Boiler Seals	25
Ceramic Fiber Firewall Plates	25
Jacket Assembly	26
Burner Mounting Plate / Burner Adapter Plate	30
Steam Trim	31
Water Trim	33
Burner Installation	33

Package Boilers

Preparation for Installation	33
------------------------------------	----

Common Installation Requirements

Boiler Piping - Heating Applications	34
Boiler Piping - Steam Applications	42
Boiler Piping - Domestic Hot Water (DHW) Applications	44
Tankless Heater Piping	45
Electric Wiring.....	46

SECTION IV - OPERATING INSTRUCTIONS

Filling System.....	50
Adjusting Controls	50
Adjusting Burner	51
Test Controls	51
Initial Cleaning, Steam Boilers	51
Initial Cleaning, Water Boilers	52
Frequent Water Addition	53
Oxygen Corrosion	53

SECTION V - SERVICE INSTRUCTIONS

Cleaning Boiler Heating Surfaces	54
Maintenance of Low Water Cutoff Devices	55
Checking Burner & Controls.....	56
Lubrication	56
General Maintenance Considerations.....	56
Attention to Boiler While Not in Operation.....	56

TABLE OF CONTENTS - Continued

SECTION VI - BURNER SPECIFICATIONS

Beckett Burners (Table VI).....	57
Power Flame Burners (Table VII).....	58
Webster Burners (Table VIII).....	61
Carlin Burners (Table IX).....	64

SECTION VII - REPAIR PART

Regional Office Directory	65
Jacket Assembly	66
Bare Boiler Assembly.....	70
Steam/Water Trim.....	74

WARRANTY	REAR COVER
-----------------------	------------



TABLE I - RATINGS/DATA



(1)

(2)

(3)

BOILER MODEL	BOILER HORSEPOWER	I=B=R GROSS OUTPUT MBH	NET I=B=R RATING			I=B=R BURNER INPUT		HEATING SURFACE (SQ. FT.)		NET FIREBOX VOLUME (CU. FT.)	PRESSURE IN FIREBOX (INCHES WTR. COLUMN)	WATER CONTENT (GALLONS)		BOILER WEIGHT W / WATER (LBS.)		I=B=R VENT DIA. (INCHES)
			SQ. FT. STEAM	MBH STEAM	MBH WATER	OIL (GPH)	GAS (MBH)	STEAM	WATER			STEAM	WATER	STEAM	WATER	
V1104	19.9	667	2083	500	580	5.8	837	64.6	74.4	7.9	0.35	59	72	2596	2704	8
V1105	25.6	857	2679	643	745	7.4	1068	83.5	96.2	10.6	0.36	68	84	3076	3210	8
V1106	31.9	1069	3342	802	930	9.2	1328	102.4	118.0	13.2	0.37	77	96	3561	3720	8
V1107	38.3	1281	4013	963	1114	11.0	1588	121.3	198.8	15.9	0.42	87	108	4050	4225	10
V1108	45.3	1517	4829	1159	1319	13.0	1876	140.2	161.6	18.5	0.42	96	120	4533	4733	10
V1109	51.7	1729	5563	1335	1503	14.8	2136	159.1	183.4	21.1	0.39	105	132	5022	5247	10
V1110	58.0	1941	6279	1507	1688	16.6	2396	177.0	204.2	23.8	0.42	115	144	5515	5757	12
V1111	64.3	2154	6967	1672	1873	18.4	2656	195.9	226.0	26.5	0.40	124	156	5997	6263	12
V1112	69.7	2334	7550	1812	2030	20.0	2887	214.8	247.8	29.1	0.42	133	169	6482	6782	12
V1113	74.8	2503	8096	1943	2177	21.5	3103	233.7	296.6	31.8	0.40	143	181	6962	7279	12
V1114	81.6	2730	8833	2120	2374	23.5	3392	252.6	291.4	34.4	0.38	152	193	7450	7792	14
V1115	88.3	2957	9567	2296	2571	25.5	3680	271.5	313.2	37.1	0.36	161	205	7942	8309	14
V1116	93.4	3126	10113	2427	2718	27.0	3897	290.4	335.0	39.7	0.38	171	217	8432	8816	14
V1117	100.2	3353	10846	2603	2916	29.0	4186	309.3	356.8	42.4	0.41	180	229	8916	9325	14
V1118	106.9	3580	11583	27780	3113	31.0	4474	328.7	377.6	45.0	0.39	189	241	9397	9831	16
V1119	111.7	3739	12096	2903	3251	32.5	4691	346.1	399.4	47.7	0.38	199	253	9889	10338	16
V1120	118.2	3957	12800	3072	3441	34.5	4979	365.0	421.2	50.3	0.38	208	265	10371	10845	16
V1121	124.7	4174	13504	3241	3630	36.5	5268	383.9	443.0	53.0	0.40	217	277	10861	11360	16
V1122	129.5	4334	14021	3365	3769	38.0	5485	402.8	464.8	55.6	0.41	227	290	11347	11872	18
V1123	136.0	4551	14721	3533	3957	40.0	5733	421.7	486.6	58.3	0.43	236	302	11831	12381	18

(1) SUFFIX "S" INDICATES STEAM BOILER, "W" INDICATES WATER BOILER. SUFFIX "G" INDICATES GAS-FIRED, "O" INDICATES OIL-FIRED, "GO" INDICATES COMBINATION GAS-OIL FIRED.

(2) I=B=R NET RATINGS SHOWN ARE BASED ON PIPING AND PICKUP ALLOWANCES WHICH VARY FROM 1.333 TO 1.288 FOR STEAM AND 1.15 FOR WATER.

CONSULT MANUFACTURER FOR INSTALLATIONS HAVING UNUSUAL PIPING AND PICKUP REQUIREMENTS, SUCH AS INTERMITTENT SYSTEM OPERATION, EXTENSIVE PIPING SYSTEMS, ETC.

THE I=B=R BURNER CAPACITY IN GPH IS BASED ON OIL HAVING A HEAT VALUE OF 140,000 BTU PER GALLON.

(3) BOILER RATINGS ARE BASED ON 13.0% CO₂ (OIL) AND 10.0% CO₂ (NATURAL GAS) AND + .10" WATER COLUMN PRESSURE AT BOILER FLUE OUTLET.

RATINGS SHOWN ABOVE APPLY AT ALTITUDES UP TO 1000 FEET ON OIL AND 2000 FEET ON GAS. FOR ALTITUDES ABOVE THOSE INDICATED, THE RATINGS SHOULD BE REDUCED AT THE RATE OF 4% FOR EACH 1000 FEET ABOVE SEA LEVEL.

SAFETY (RELIEF) VALVE SET PRESSURE:

USA BOILER

STEAM - 15 PSI

WATER - 50 PSI

OPTIONAL WATER - 30 PSI

- 80 PSI

CANADIAN BOILER

STEAM - 15 PSI

WATER - 50 PSI

OPTIONAL WATER - 30 PSI

SECTION I - GENERAL INFORMATION (continued)

A. INSPECT SHIPMENT carefully for any signs of damage.

1. ALL EQUIPMENT is carefully manufactured, inspected and packed. Our responsibility ceases upon delivery of crated Boiler to the carrier in good condition.
2. ANY CLAIMS for damage or shortage in shipment must be filed immediately against the carrier by the consignee. No claims for variances from, or shortage in orders, will be allowed by the manufacturer unless presented within sixty (60) days after the receipt of goods.

B. LOCATE THE UNIT

NOTICE

Recommended clearance for service may be reduced to minimum clearance to combustible material. However, increased service and maintenance difficulty will result.

1. RECOMMENDED SERVICE CLEARANCE

- Locate the unit in the boiler room so as to provide ease of venting and adequate clearance for maintenance, serviceability, and installation of piping. Refer to Figure 1 for boiler dimensional data.

FRONT --- Provide 54" service clearance for removal, maintenance, and servicing of burner and controls.

REAR --- Provide a minimum service clearance from the boiler jacket for access to pressure relief door, flame observation port, rear flue damper and vent piping, relief valve, and boiler return piping. See following chart.

LEFT SIDE --- Provide a minimum clearance from the boiler jacket of 36" for cleaning of flueways.

RIGHT SIDE --- Less Tankless Heater - Provide a minimum clearance from boiler jacket of 12".

With Tankless Heater - Provide a minimum clearance from the boiler jacket of 35" for installation and removal of tankless heater(s).

TOP --- Provide a minimum clearance from the boiler jacket of 24".

2. FOR MINIMUM CLEARANCES to combustible materials, See Table II.
3. PROVIDE ADEQUATE FOUNDATION for the unit. Refer to Figure 2.

Table II: Minimum Installation Clearances To Combustible Materials (Inches)

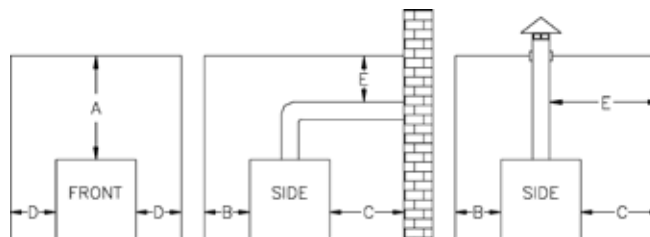

Boilers with Top Flue Outlet

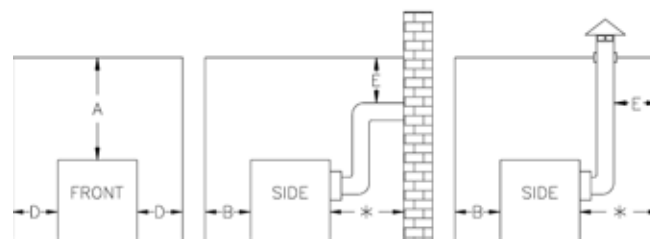

Boilers with Rear Flue Outlet

A	B	C	D	E
Above	Front	Rear	Sides	Vent Connector
6	24	6	6	18

*** See Table III for recommended service clearance to access rear of boiler.**

NOTE 1: Listed clearances comply with American National Standard ANSI/NFPA 31, Installation of Oil Burning Equipment.

NOTE 2: V11 Series boilers can be installed in rooms with clearances from combustible material as listed above. Listed clearances cannot be reduced for alcove or closet installations.

NOTE 3: For reduced clearances to combustible material, protection must be provided as described in the above ANSI/NFPA 31 standard.

Table III: Recommended Rear Service Clearance

Flue Outlet Size	Top Flue Outlet	Rear Flue Outlet	
		Combustible Surfaces	Non-Combustible Surfaces
8" Dia.	18"	42"	27"
10" Dia.		45"	30"
12" Dia.		48"	33"
14" Dia.		49"	34"
16" Dia.		52"	37"
18" Dia.		54"	39"

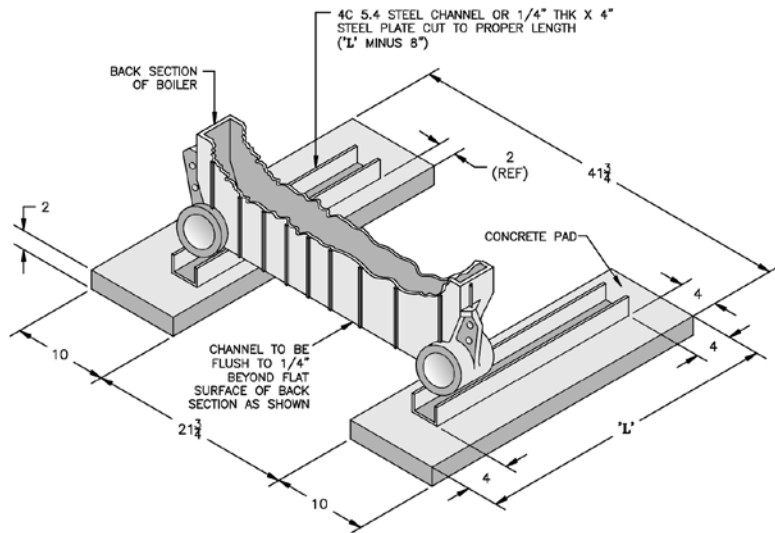

NO. OF SECTIONS	'L' CONCRETE LENGTH	NO. OF SECTIONS	'L' CONCRETE LENGTH
4	32	14	93-1/4
5	38-1/4	15	99-1/2
6	44-1/4	16	105-1/2
7	50-1/2	17	111-3/4
8	56-1/2	18	117-3/4
9	62-3/4	19	124
10	68-3/4	20	130
11	75	21	136-1/4
12	81	22	142-1/4
13	87-1/4	23	148-1/2

Figure 2: Boiler Foundation

WARNING

Boiler is suitable for installation on combustible floor. Do not install boiler on carpeting.

Floor construction should have adequate load bearing characteristics to bear the weight of the boiler filled with water (see Table 1). A boiler foundation similar to the one shown in Figure 2 is recommended if the boiler room floor is weak or uneven or if a water condition exists.

- PROVIDE AIR SUPPLY AND VENTILATION to accommodate proper combustion.

WARNING

Failure to supply adequate air to the boiler will result in unsafe boiler operation.

For commercial and industrial equipment, permanent facilities for supplying an ample amount of outside air shall be provided in accordance with the following.

For boiler rooms adjacent to outside walls, and where combustion air is provided by natural ventilation from the outside, there shall be a permanent air supply inlet having a total free area of not less than 1 sq. in. per 4,000 Btu per hr. (35 sq. in. per gal. per hr.) (5.5 cm² per kw.) of total input rating of the burner or burners and in no case less than 35 sq. in. (0.425 m²).

For boiler rooms not adjacent to outside walls, the combustion air shall be supplied in a manner acceptable to the authority having jurisdiction.

- In the absence of local requirements, the confined space shall be provided with two

permanent openings, one in or near the top of the room and one near the bottom. The openings shall communicate by means of ducts, with the outdoors or to such spaces (crawl or attic) that communicate with the outdoors.

- Where communicating by means of vertical ducts, each opening shall have a free area of not less than 1 sq. in. per 4,000 Btuh (35 sq. in. per gph.) (5.5 cm² per kw) of total input rating of all appliances in the enclosure.
- If horizontal ducts are used, each opening shall have a free area of not less than 1 sq. in. per 2,000 Btuh (70 sq. in. per gph.) (11 cm² per kw) of total input of all appliances in the enclosure.

5. CHIMNEY OR VENT

NOTICE

When a V11 gas fired boiler is connected to a venting system that is designed so that it will operate under a negative pressure, the use of Type C, B, or other manufactured vent systems designed for negative pressure is acceptable.

When a V11 oil fired or combination gas/oil fired boiler is connected to a venting system that is designed so that it will operate under a negative pressure, the use of Type C, L or other manufactured vent systems designed for negative pressure is acceptable.

Unlined masonry chimneys are not acceptable. Lined masonry chimneys are acceptable with the appropriate vent connectors using materials described above.

WARNING

When a V11 gas fired boiler is connected to a venting system that is designed so that it will operate under a positive pressure, manufactured vent systems, designed and approved for positive pressure application per UL1738, must be used (for example, Van-Packer model CS, Protech Model FasNSeal / FasNSeal W2, Heatfab Saf-T-Vent or equivalent).

When a V11 oil fired or combination gas/oil fired boiler is connected to a venting system that is designed so that it will operate under a positive pressure, manufactured vent systems, designed and approved for positive pressure application, must be used (for example, Selkirk Metalbestos Model PS / IPS, Van-Packer Model ES or equivalent).

The V11 Series boiler is designed for forced draft firing and may be used with a conventional natural draft stack (15' minimum height) or a stub vent, sometimes called a diesel stack (see Figure 3a). See Table I for the proper vent outlet size. For low silhouette vent terminations, see Figure 3b. Draft controls are not normally required, although they may be used on installations where a natural draft stack is used or on multiple boiler installations with a common stack. The boiler is provided with a breeching damper, which should be adjusted to maintain a positive pressure of 0.1" W.C. in the vent connector box during burner high fire operation (see breeching pressure sensing port in Figure 1).

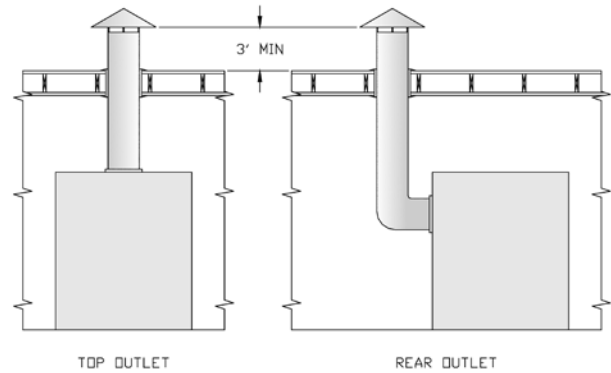

Figure 3a: Typical Arrangement For Stub Vent

If the venting system is designed for positive or forced draft venting, the boiler, vent connector and stack will operate under positive pressure. Gas tight vent systems designed for pressure systems must be used to prevent flue by-product leakage. The vent height is usually limited to prevent negative draft, typically three (3) feet above the roof line (see Figure 3a). The damper shall be adjusted to maintain a positive pressure of 0.1" W.C. in the vent connector box during burner high fire operation (see breeching pressure sensing port in Figure 1).

If the venting system is designed for negative pressure (natural draft), the boiler still operates with positive pressure in the chamber and up to the fixed damper on the flue collar. However, if the venting system is larger than what is required, the stack will provide a surplus draft (or negative pressure) that may require the use of a barometric damper to maintain the positive 0.1" W.C. pressure at the flue outlet. Multiple forced draft boiler stacks should always be designed as negative to ensure the products of combustion do not exit a boiler that is not firing.

WARNING

Venting instructions are recommendations only. Consult a venting expert on the design of a specific vent system for your application. The ASHRAE Venting Guide and The National Fuel Gas Code, NFPA 54 should be considered in all venting systems.

Conventional vent material may not be suitable for the application. Flue gases can leak carbon monoxide from the joints on these materials and can result in severe personal injury or death.

Installations having long horizontal runs or an excessive amount of tees or elbows will restrict the flow of combustion gases and can result in condensation, flue gas leakage of carbon monoxide, resulting in severe personal injury or death.

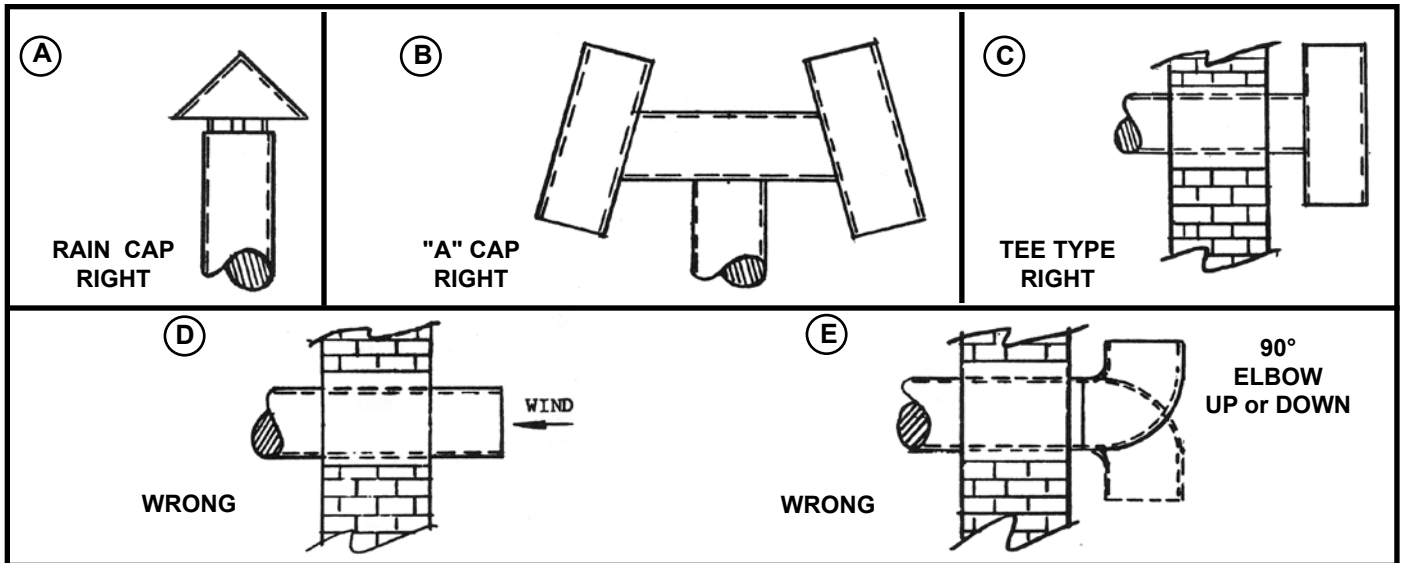

VENT SIZING - Area must be the same as or greater than the boiler breeching (Smoke Outlet). A barometric damper may be required on installations with a high draft condition.

FAULTY BOILER BURNER OPERATION

1. If improper vent is suspected, remove pipe at breeching and operate boiler. This will determine if excessive down draft, blocked or restricted flue, etc. is causing the problem.
2. If using type shown in A above, be sure cap is raised sufficiently above main pipe to allow flue gases to vent unimpeded.
3. A popular type cap is shown in B.
4. The tee is frequently used as shown in C.
5. D and E should not be used due to possible fluctuations in back pressure.

Figure 3b: Vents — Faults & Suggestions
Typical Vents that are used on Forced Draft Boilers, on Low Silhouette Buildings

SECTION II - CAST IRON BLOCK ASSEMBLY

A. FACTORY ASSEMBLED SECTIONS - The assemblage should be set in the proper location as outlined in Section I. Lifting arrangement and weights are given in Figure 4.

THEN THE DRAW-UP ROD NUTS SHOULD BE LOOSENED UNTIL FINGER TIGHT AND THEN TIGHTENED ½ TURN WITH A WRENCH. Now proceed to Paragraph C of this section, "HYDRO-STATIC TEST".

B. FIELD ASSEMBLED SECTIONS - If the boiler was ordered to be field assembled, follow the assembly procedure outlined on the following pages.

1. ASSEMBLY OF SECTIONS (MANUAL DRAW-UP)

These sections are designed to be drawn together one section at a time using the 11" long draw-up rods (provided) and ordinary hand tools.

Tools required:

- (1) ¾" Drive Ratchet
- (1) 1¼" Socket
- (1) 1¼" Combination or Open End Wrench
- (1) Can Thread Cutting Oil or Grease

WHEN ASSEMBLING SECTIONS WITHOUT HYDRAULIC DRAW-UP EQUIPMENT, NEVER ASSEMBLE MORE THAN ONE SECTION AT A TIME.

- a. Place the rear section in its approximate final position, as outlined in Section I and support it with a suitable prop. See Figure 5.

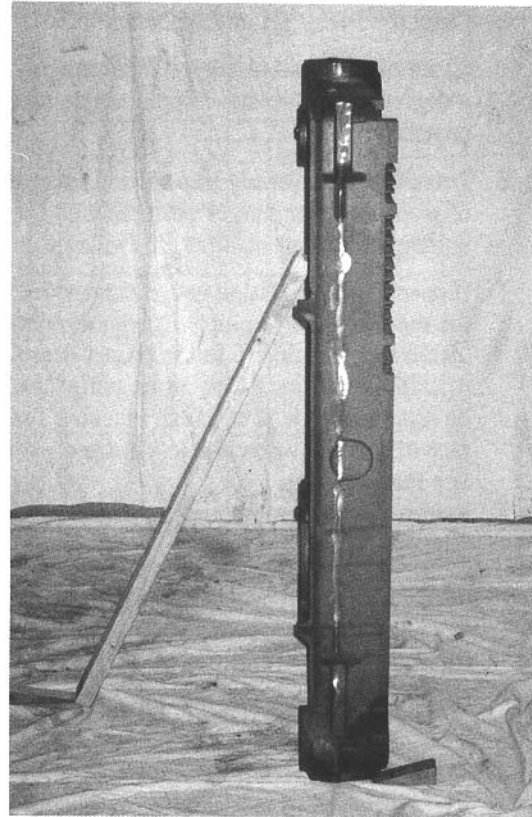

Figure 5: Positioning of Back Section

NUMBER OF SECTIONS	LIFTING WEIGHT (LBS)	MIN. SLING LENGTH 'L'
4	1833	7'
5	2226	8'
6	2618	8'
7	3010	9'
8	3403	9'
9	3795	10'
10	4188	10'
11	4580	11'
12	4972	11'
13	5365	12'
14	5757	12'
15	6150	13'
16	6542	13'
17	6934	14'
18	7327	14'
19	7719	15'
20	8112	15'
21	8504	16'
22	8896	16'
23	9289	17'

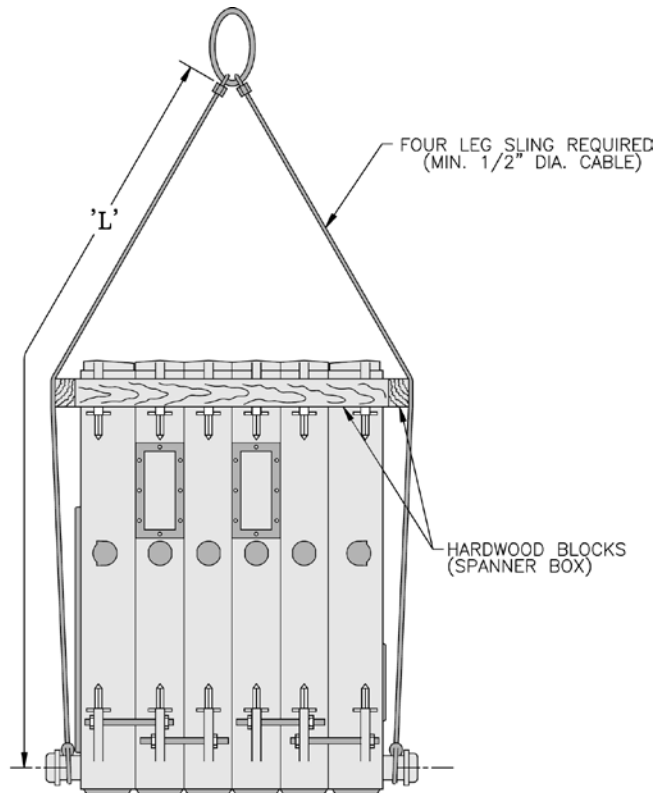

Figure 4: Lifting Instruction

- b. On sizes 1104 thru 1106 only - Open target wall carton, apply silastic to back of target wall and secure target wall to rear section.
- c. Clean the groove in the ground joint along the edge of the section with the wire brush.
- d. Open the Boiler Assembly Carton(s) and remove the bottle of adhesive. Using the dauber supplied in the bottle, apply the adhesive to the groove. Be sure to use enough adhesive to sufficiently coat the entire groove surface. If so desired, a multi-purpose spray adhesive (supplied by others) may be used instead. **HOWEVER, GREAT CARE MUST BE TAKEN TO ENSURE THAT THE ADHESIVE DOES NOT COME IN CONTACT WITH THE NIPPLES OR NIPPLE PORTS.**
- e. While the adhesive is becoming tacky, clean the nipples and nipple ports thoroughly with a degreasing solvent. Use the Loctite #592 supplied to lubricate the nipples and nipple ports. Apply the lubricant to the nipples and nipple ports, then use a brush to disperse it evenly around the nipples and nipple ports. Use approximately 25 ml of Loctite #592 per flueway [(1) 7" and (2) 3" nipples and their (6) corresponding nipple ports].
- f. Drive nipples squarely into section using block of wood and hammer, or preferably, an aluminum head hammer. Burnham offers a polyethylene block for setting the nipples (part no. 8052601). Place block over entire nipple edge and hit the wood with the hammer.

WARNING

Nipples must be driven in evenly and to the proper depth to assure tight joints. Most nipple leaks are caused by tilted or cocked nipples.

DO NOT use steel/iron head hammer to drive nipples without using a wood block. Nipple damage may result.

- g. A special nipple setting gauge is provided for the nipples. Gauge nipple at 90° angles to insure that it is driven to the proper depth into the nipple opening (nipple port). Cut-out in gauge must rest on nipple, with the legs of the gauge touching finished face of section, when nipple is properly driven. See Figure 6.
- h. Remove a 127" length of fiberglass rope from the assembly carton. Starting with the area around the upper 7" nipple port, firmly press the rope into the groove, so that the adhesive holds it in place. (If more than 25 minutes have passed since the adhesive was applied, it may be necessary to reapply.) Continue to affix the rope to the groove in this fashion around the perimeter of the section. Make sure that the rope does not droop or hang outside of the groove. When the

end of the groove is reached, cut off the excess rope. Push the length of the excess rope into the groove at the top corner of the section face end of the groove is reached, cut off the excess rope. Push the length of the excess rope into the groove at the top corner of the section face (opposite of the 7" nipple port). Cut off and discard any remaining rope after groove is filled. See Figure 7.

- i. From the "Section Arrangement" chart, select the next section according to the "Identification Code" at the top of the chart. See Figure 8.

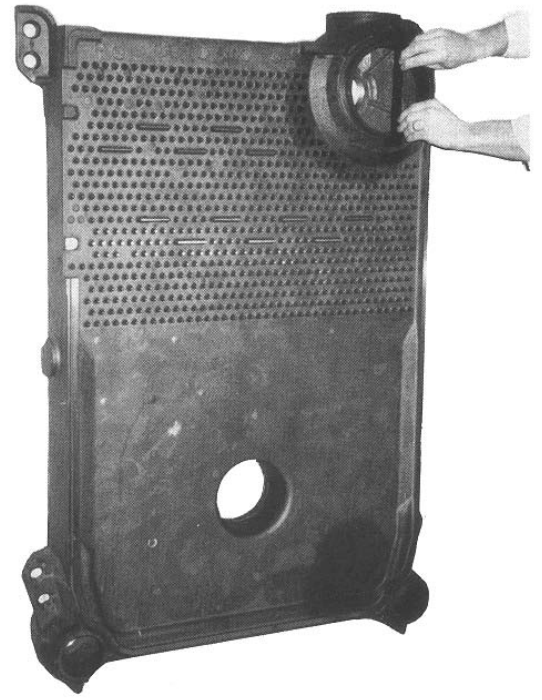

Figure 6: Setting of Nipples



Figure 7: Affixing the Fiberglass Rope

NOTICE

The sections must be assembled according to the arrangement shown to ensure proper operation, proper assembly of canopy, jacket and alignment of piping and tankless heaters with jacket knockouts. Start with the back section and work towards the front.

Use a brush to clean the groove in the face of the next section. Then, using a cartridge of RTV 6500 or RTV 736 sealant in a caulking gun, fill the groove in this section with the silastic sealant. Touch-up any missed spots before draw-up. Touch-up after draw-up has no value.

WARNING

This is a forced draft fired boiler and sealant must be applied where specified for proper and safe performance. Burnham Commercial has approved section joint sealants (silastics) manufactured by Dow-Corning under the product number RTV 736, and Sil-Bond under the product number RTV 6500.

WARNING

Sections must be drawn-up tight immediately after properly applying sealant for best results. Although sections may be joined within two (2) hours of applying sealant, humidity and temperature affect cure time. If a "thick skin" has been formed on the sealant bead, remove and re-apply sealant.

Sealant must be properly applied to ALL boiler joints. Failure to properly seal the boiler joints will result in combustion gas leaks through the joint. DO NOT operate boiler with combustion gas leaks.

- j. Clean and lubricate nipple ports on next section to be assembled and place on nipples previously installed in rear section. To facilitate assembly, it is advisable to enter the upper nipple first in its port. Then enter the lower nipples in their respective ports. If necessary, place a lifting bar (crowbar) under the center of the section and lift the nipple port onto the upper nipple. Drive section in place with a heavy block of wood, striking blows as squarely as possible over nipple ports.
- k. Large draw-up rod lugs with dual holes are cast in the four corners of each casting. STARTING WITH THE UPPER HOLES, install four 3/4" x 11" long draw-up rods along with washers and nuts (see Figure 9).

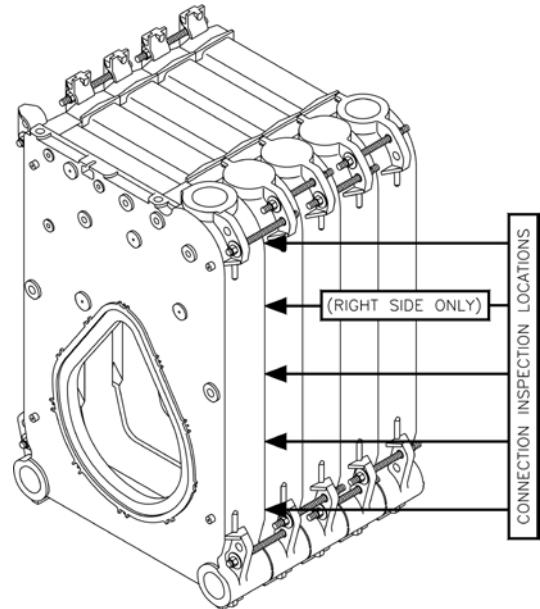

Figure 9: Connection Inspection Locations and Manual Draw-Up Tie Rod Pattern

CAUTION

To avoid damage to the draw-up rod threads while drawing up sections, apply oil or other lubricant to tie rod threads while assembling sections to prevent stripping of threads on rod and to make assembling easier.

1. DRAW UP SECTION SLOWLY AND EVENLY using an alternating pattern starting with the upper right lug (closest to the 7" port) and proceeding to the lower left, lower right and finishing with upper left lug. When you start, grind surfaces between adjoining sections should be approximately 3/8" apart. Use three (3) or four (4) passes at tightening the four (4) draw-up rods a little at a time so that sections are pulled up evenly. During the last pass, pay close attention to the silastic sealant as it squeezes when the sections come in close contact. The silastic sealant should continue to squeeze out wafer thin until the sections are connected metal to metal. If the silastic has stopped squeezing out from the connection and the sections still do not appear to be drawn metal to metal, use a feeler gauge to measure any gaps at the locations identified in Figure 9. (Unless specified otherwise, gaps should be measured at these locations on both sides of the sections). A maximum gap of .025" is acceptable. Measure gaps at the outer edge of the connection only, making sure not to puncture the gasket created by the silastic and rope.

WARNING

When tightening the draw-up nuts, **DO NOT EXCEED 165 FT -LB. OF TORQUE.** If the maximum torque limit has been reached and a gap greater than .025" still exists between the sections, consult the sales representative.

KEEP NIPPLES ALIGNED WITH NIPPLE PORTS. If necessary, tap edge of nipples lightly with a blunt tool or rod to keep nipples from cocking while sections are being drawn-up. **DO NOT DRAW UP SECTION WHEN NIPPLES ARE COCKED.** If the torque required becomes excessive, periodically place a heavy block of wood over each nipple port and strike as squarely as possible with several blows to relieve tension on the draw-up rods.

- m. CONTINUE ASSEMBLING SECTIONS IN THEIR RESPECTIVE ORDER alternating the draw-up rods from the upper to lower set of holes in draw-up lugs. Be certain that all sections are drawn up IRON-TO-IRON at all three (3) nipple ports.

BE SURE TO APPLY THE FIBERGLASS ROPE AND SEALANT to the grooves in the ground joints between adjacent sections as the boiler operates with a positive pressure in the firebox and products of combustion will escape between sections unless they are properly sealed. The rope and sealant should be applied before each section is placed on the assembly.

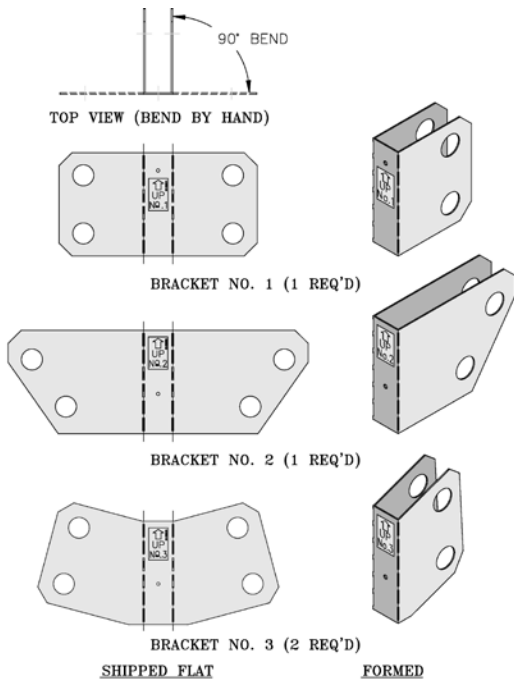

Figure 10: Jacket Intermediate Panel Mounting Brackets

(Required on Boiler Models V1113 thru V1123)

IMPORTANT

JACKET SUPPORT BRACKETS must be attached to the appropriate center section during the assembly process on boiler sizes V1113 thru V1123. Check "Section Arrangement" Chart for location of center section to which jacket support brackets must be attached (see Figure 8 on Page 16).

- i. LOCATE JACKET INTERMEDIATE PANEL MOUNTING BRACKETS NO. 1, NO. 2 AND NO. 3 IN JACKET CARTON. Brackets are shipped flat and must be formed by hand, bend as shown in Figure 10.
- ii. WHEN APPROPRIATE SECTION is being assembled to block, slide brackets over draw-up rod lugs prior to inserting draw-up rods, washers and nuts. To prevent the brackets from turning during the draw-up process, insert a large punch or draw-up rod through second hole in each

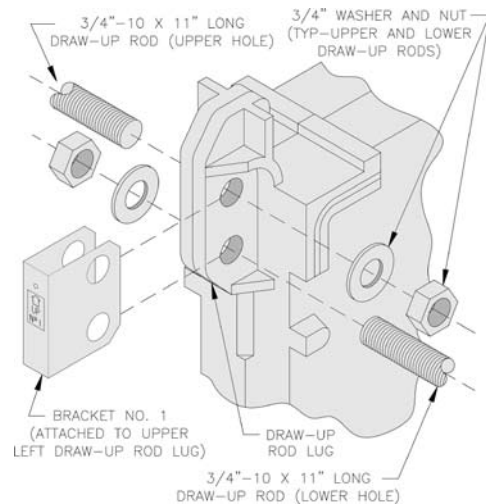

Figure 11: Bracket Placement

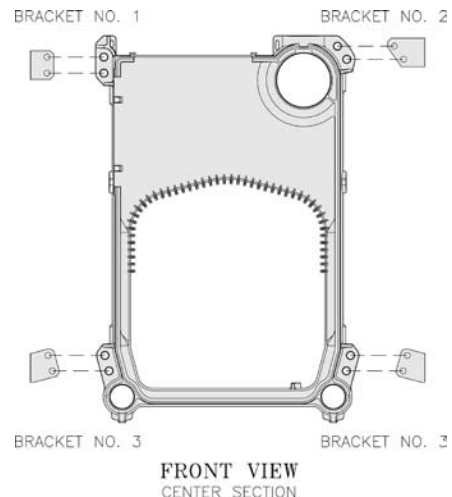

Figure 12: Bracket Attachment to Center Section

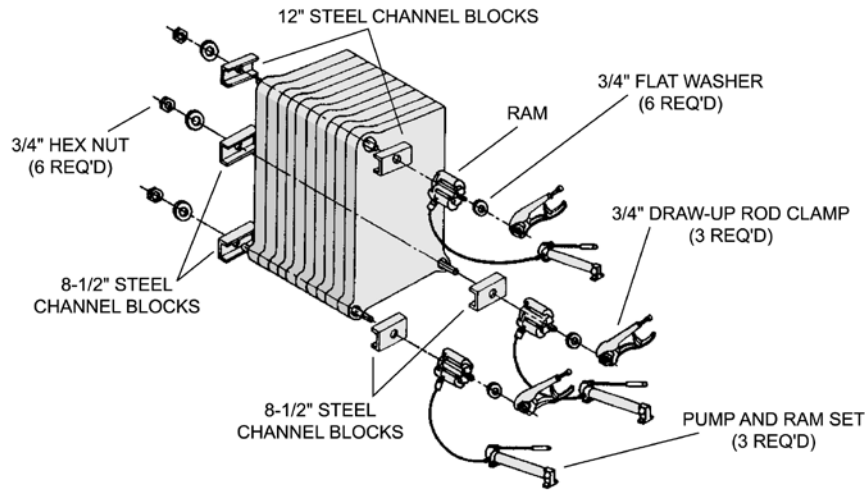

Figure 13: Hydraulic Draw-Up of Sections

bracket. Refer to Figures 11 and 12 for proper location of each bracket and typical attachment.

Spacing of more than 3/8" will limit number of sections that can be drawn up in one unit and could indicate cocked nipples.

- n. If a joint springs apart it must be re-drawn tight within four (4) hours of the time of application of Silastic to that joint.
- o. EXCESS LENGTH OF DRAW-UP RODS must not extend beyond front and rear sections to ensure proper fit of jacket, adjust accordingly.
- p. AFTER ALL SECTIONS HAVE BEEN DRAWN UP, THE DRAW-UP ROD NUTS SHOULD BE LOOSENED UNTIL FINGER TIGHT AND THEN TIGHTENED ½ TURN WITH A WRENCH.
- q. Now Proceed to Paragraph C of this section, Hydrostatic Test.

2. ASSEMBLY OF SECTIONS (HYDRAULIC DRAW-UP)

V1104 through V1112 Section Assemblies

The entire assemblage may be drawn-up at one time using the hydraulic draw-up equipment providing the operation is completed within four (4) hours after application of the sealant.

V1113 through V1123 Section Assemblies

The total assemblage should be first drawn-up into two (2) sub-assemblies. Each sub-assembly may be drawn-up at one time using the hydraulic draw-up equipment providing the operation is completed within four (4) hours after the application of the sealant.

"Hydraulic Draw-Up Equipment" is available through Burnham by ordering part number 6196008.

- a. Repeat steps 1a through 1j under "Field Assembled Sections (Manual Draw-Up)".
- b. Continue driving sections in place (in their respective order) until all sections are in the assemblage. Ground surfaces between adjoining sections should be spaced 1/4" to 3/8" apart.

WARNING

Sealant must be properly applied to ALL grooves. Failure to properly seal the boiler joints will result in combustion gas leaks through the joint. DO NOT operate boiler with combustion gas leaks. The sealant should be applied before each section is placed on the assembly.

On long boiler assemblies, it may be necessary to draw up a partial block if the entire boiler is not ready to be drawn up tight within four (4) hours of the first application of the Silastic. If the block assembly time extends overnight, the partial block completed must be drawn up tight before leaving the boiler overnight. If a joint springs out, it must be re-drawn tight within four (4) hours of first application of Silastic to the joint.

- c. Insert the three 3/4" draw-up rods (and couplings, if appropriate) through the tapped holes in the rear section extending them through the tapped holes in the front section. Be sure to screw draw-up rods into couplings far enough to prevent stripping threads.
- d. Place a 12" long steel channel on each end of the upper draw-up rod and an 8½" long steel channel on each end of the lower draw-up rods. Install nuts and washers on one end of the draw-up rods and the hydraulic rams, washers and draw-up rod clamps on the other. See Figure 13.
- e. Draw-Up Sections
Use hydraulic rams to draw up sections by applying pressure alternately on the draw-up rods. When rams reach stroke limit, release pressure in ram pumps and then move clamps to new position.

CAUTION

Do not apply pressure directly on threaded tappings on front and rear sections with draw-up channels during assembly procedures.

Rods should be approximately centered in openings so that rods and couplings (when used) do not drag on pipe thread in end section tappings.

WARNING

READ THE STATEMENTS BELOW BEFORE ATTEMPTING TO USE HYDRAULIC EQUIPMENT.

- Release pressure in ram pumps before attempting to remove clamps.
 - Do not stand in line with draw-up rods at either end when hydraulic pressure is being applied. As a safety measure, ends of draw-up rods should be covered while sections are being drawn in case rods should snap while under tension.
 - Do not operate ram against draw-up coupling.
 - Do not operate pump after ram has reached stroke limit.
- f. Continue to draw-up until all sections make contact at the ground joints.
- g. After all sections have been drawn up, but before removing the hydraulic rams and draw-up rods, the 11" long tie-rods must be installed.
- Large draw-up rod lugs with dual holes are cast in the four (4) corners of each casting. Starting with the upper holes in the back section, install four (4) $\frac{3}{4}$ " x 11" long tie rods along with washers and nuts. Continue installing the tie rods alternating from the upper to lower set of holes in draw-up lugs until front section is secured. Be certain that all sections are drawn up iron to iron at all three nipple ports.

IMPORTANT

Jacket Support Brackets must be attached to the appropriate center section during this process. Check "Section Arrangement" chart for location of center section to which jacket support brackets must be attached (see Figure 8).

- i. LOCATE JACKET INTERMEDIATE PANEL MOUNTING BRACKETS NO. 1, NO. 2, AND NO. 3 IN JACKET CARTON. Brackets are shipped flat and must be formed by hand, bend as shown in Figure 10.

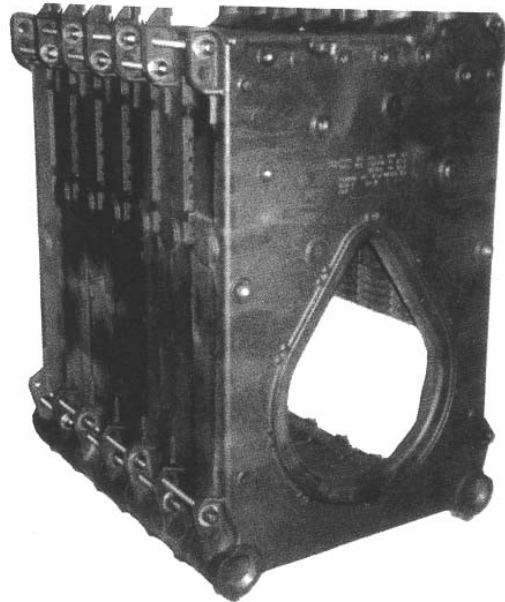

Figure 14: Boiler Section Assemblage

Brackets are shipped flat and must be formed by hand, bend as shown in Figure 10.

- ii. Slide brackets over draw-up rod lugs prior to inserting the 11" long tie rods, washers and nuts. Refer to Figures 11 and 12 for proper location of each bracket and typical attachment method.

- h. Excess length of draw-up rods must not extend beyond front and rear section to ensure proper fit of jacket, adjust accordingly. **TIGHTEN ALL TIE ROD NUTS UNTIL FINGER TIGHT. THEN TIGHTEN THEM AN ADDITIONAL $\frac{1}{2}$ TURN WITH A WRENCH.**

- C. HYDROSTATIC TEST** - After the boiler sections have been assembled, it is essential that the boiler be hydrostatically tested before the canopy, flue cover plates, jacket, or piping is installed.

1. Tankless Heater Installation

If boiler is ordered with tankless heaters, install heaters with the gaskets provided. Table V gives the maximum number of heaters permissible per assemblage and the heater ratings.

2. Plug all boiler tappings and fill entirely with cold water.

CAUTION

DO NOT install gauge until after hydrostatic testing the boiler. Gauge failure may result.

3. All completed boilers shall satisfactorily pass the prescribed hydrostatic test.
- a. STEAM BOILERS: The assembled boiler shall be subjected to a hydrostatic test of not less than 45 psig.

b. **HOT WATER BOILERS:** The assembled boiler shall be subjected to a hydrostatic test of not less than 1½ times the maximum allowable working pressure, as established by the relief valve provided with the boiler. For example, a boiler with a 50 psi relief valve must be subjected to a test pressure of 75 psig to 85 psig.

WARNING

Failure to properly hydrotest all boilers at the correct pressure may result in section assembly failure in operations.

4. **EXAMINE BOILER CAREFULLY, INSIDE AND OUTSIDE**, to insure against leaks from cocked nipples or through concealed breakage caused in shipping and handling. This precaution is for your protection and will simplify handling of necessary replacements and adjustment claims.
5. After making certain that there are no leaks, drain boiler and remove plugs for boiler trim and other connections.

SECTION III - INSTALLATION INSTRUCTIONS (continued)

A. CANOPY/FLUE OUTLET ASSEMBLY, Refer to Figures 15, 16 and 17.

1. Open canopy carton.
2. Two piece canopies should be joined together using the 1/8" x 1" wide self-adhesive fiber gasket and seventeen (17) #10 x 1/2" sheet metal screws.
3. Attach the canopy bracket to the front end cap of canopy with four (4) #10 x 1/2" sheet metal screws.
4. Across the top of the front section and along the top ledges running back each side of the sections, place continuous 2" wide strips of cerafelt and overlap joints at front corners. Cerafelt strip should extend 1/4" beyond raised flange on rear surface of back section. Cut off excess.
5. Place the canopy on the sections.
6. Position rear flange (end with studs) of canopy flush with raised flange on rear of back section.
7. Loosely attach the canopy bracket to the lug on the front of the section assembly with 5/16" carriage bolt, flat washer and lock-nut.
8. Attach canopy hold down channels to center sections with appropriate canopy 'J' bolts. Insert threaded end through holes in channels and hook 'J' bolts on center section lugs (hooks should face forward). Loosely secure canopy with 5/16" flat washers, lock washers and brass nuts.
9. Check to see if rear flange of canopy is still flush with raised flange on back section. Tighten rear set of canopy 'J' bolts only.
10. Open either the rear flue outlet carton (standard) or top flue outlet carton (optional).
11. Attach the 1/8" x 1" wide self-adhesive fiber gasket to the surface of either the rear flue outlet damper assembly or rear flue outlet cover that mounts against the canopy and back section. Gasket must be centered over all attachment holes. Do not overlap corners, cut butt joints.
12. Attach either the rear flue outlet damper assembly or rear outlet canopy cover to the canopy with the six (6) 5/16" flat washers, lock-washers and brass nuts. Attach the rear flue outlet damper assembly or cover to the back section with the six (6) 5/16" flat washers and cap screws.
13. Tighten front canopy carriage bolt and remaining 'J' bolts until canopy is secure.
14. Attach the 1/8" x 1" wide self-adhesive fiber gasket to the surfaces of either the top flue outlet damper assembly or top outlet canopy cover that mounts against the canopy. Gasket must be centered over all attachment holes. Do not overlap corners, cut butt joints.

15. Secure either the top flue outlet damper assembly or top outlet canopy cover with #10 x 1/2" sheet metal screws.
16. 1" thick piece of fiberglass insulation provided in canopy carton will be installed during jacket assembly, set aside until then.

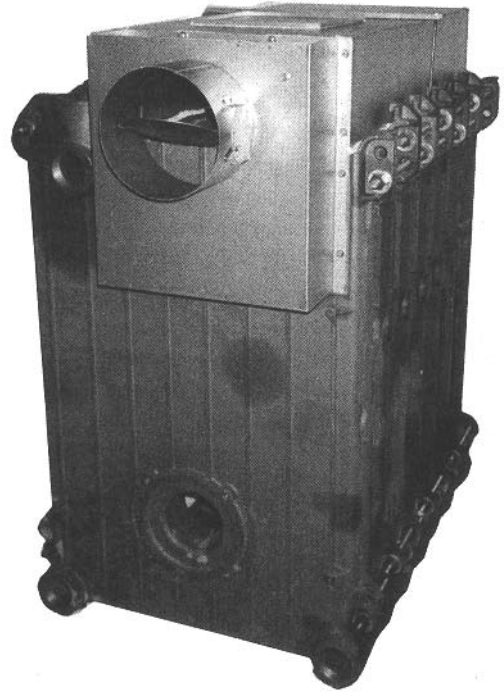

Figure 16: Canopy with Rear Flue Outlet Damper Assembly

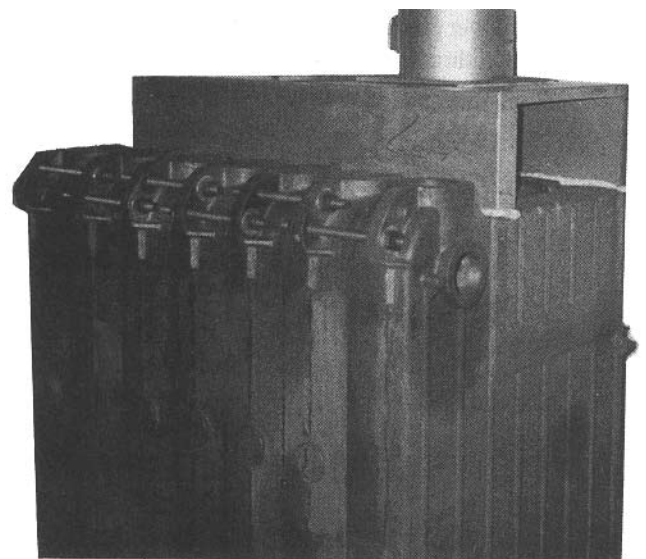

Figure 17: Canopy with Top Flue Outlet Damper Assembly (Rear Cover Removed)

Important Product Safety Information **Refractory Ceramic Fiber Product**

Warning:

The Repair Parts list designates parts that contain refractory ceramic fibers (RCF). RCF has been classified as a possible human carcinogen. When exposed to temperatures about 1805°F, such as during direct flame contact, RCF changes into crystalline silica, a known carcinogen. When disturbed as a result of servicing or repair, these substances become airborne and, if inhaled, may be hazardous to your health.

AVOID Breathing Fiber Particulates and Dust

Precautionary Measures:

Do not remove or replace RCF parts or attempt any service or repair work involving RCF without wearing the following protective gear:

1. A National Institute for Occupational Safety and Health (NIOSH) approved respirator
 2. Long sleeved, loose fitting clothing
 3. Gloves
 4. Eye Protection
- Take steps to assure adequate ventilation.
 - Wash all exposed body areas gently with soap and water after contact.
 - Wash work clothes separately from other laundry and rinse washing machine after use to avoid contaminating other clothes.
 - Discard used RCF components by sealing in an airtight plastic bag. RCF and crystalline silica are not classified as hazardous wastes in the United States and Canada.

First Aid Procedures:

- If contact with eyes: Flush with water for at least 15 minutes. Seek immediate medical attention if irritation persists.
- If contact with skin: Wash affected area gently with soap and water. Seek immediate medical attention if irritation persists.
- If breathing difficulty develops: Leave the area and move to a location with clean fresh air. Seek immediate medical attention if breathing difficulties persist.
- Ingestion: Do not induce vomiting. Drink plenty of water. Seek immediate medical attention.

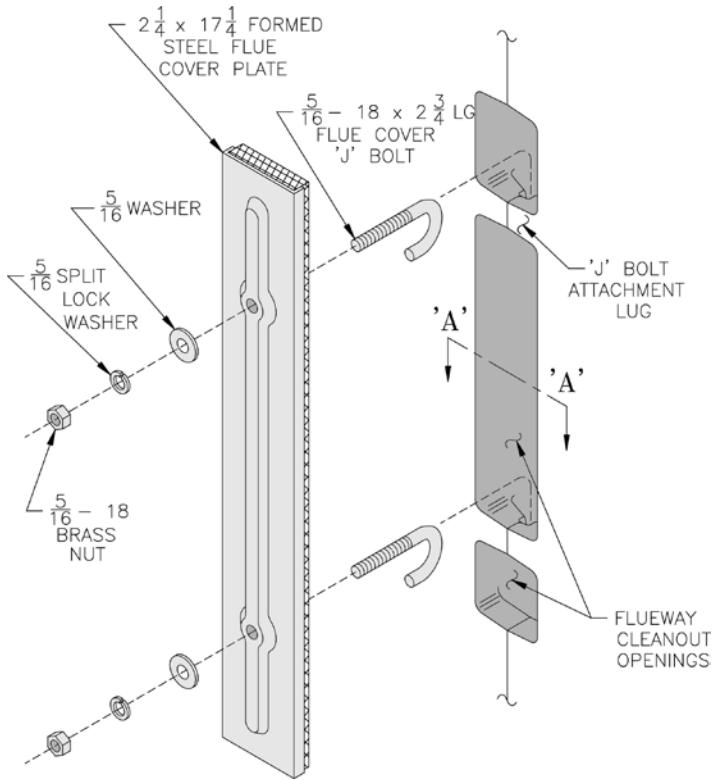

Figure 18: Flue Cover Plate Attachment

B. INSTALL FLUE COVER PLATES over cleanout openings on left side of boiler as shown in Figure 18.

WARNING

See Important Product Safety Information on Page 24 of this manual, regarding refractory ceramic fiber product warning.

1. Locate the cover plates, carriage bolts, nuts and washers in the boiler assembly carton(s).
2. Remove insulation from two 3/8" diameter holes in flue cover plates using a 3/8" drill bit which can be rotated through insulation by hand.
3. Hook flue cover 'J' bolts over attachment lugs.
4. With one hand, hold top 'J' bolt between your index and middle fingers. With the other hand, hold flue plate on a slight inward angle, align top hole with end of 'J' bolt and force it through as far as possible. Repeat similar process for bottom 'J' bolt.
5. Holding threaded end of top 'J' bolt, pull outward and at the same time push flue cover plate against castings. Place one finger across 'J' bolt at base of flue cover plate hole. Place 5/16" washer, split lock washer and brass nut on end of 'J' bolt. Hand tighten only. Repeat similar process for bottom 'J' bolt.
6. Push upward on bottom edge of flue cover plate to eliminate sag in hardware. Tighten brass nuts with a deep socket or wrench until insulation on cover plate provides an adequate seal to casting. If after

tightening, a gap is still evident where the sections join, apply silastic along top and bottom edge of insulation board.

7. Repeat steps 3 through 6 for mounting remaining flue cover plates.

C. MOUNT REAR OBSERVATION PORT COVER, Refer to Figure 15.

1. Apply a 1/4" bead of Silastic sealant along the groove on the inside face of the rear observation port cover.
2. Mount the rear observation port cover onto the rear section (with the word "Top" in the upright position) using the (4) 5/16"-18 X 1" cap screws and washers provided.

D. INSPECT SEALS

1. A visual inspection should be made of all sealed joints and repairs made if necessary. A darkened boiler room with a light source in the combustion space and canopy will aid this inspection.

E. INSTALL THE CERAMIC FIBER FIREWALL PLATES on the right side of the center sections starting at the front and working toward the back, see Figure 15 and 19. Firewall plates are shipped in the canopy carton, see chart below for quantities required.

Boiler Model	Front Firewall Plate	Common Firewall Plate
V1104/1105	1	0
V1106/1107	1	1
V1108/1109	1	2
V1110/1111	2	3
V1112/1113	1	4
V1114/1123	1	5

1. There are two different types of firewall plates identified as "Front" and "Common". All builds start with one (1) "front" firewall plate and "common" firewall plates are added as the boiler grows in size.

IMPORTANT

Models V1104 and V1106 Only. Cut-off 3/4" of excess material from rear edge of firewall plate to eliminate interference with rear target wall.

Model V1104: Remove excess from front firewall plate.

Model V1106: Remove excess from common firewall plate.

2. Firewall plates have two (2) notches located along the bottom edge which interlock with lugs cast on each center section, making them self positioning. The "front" firewall plate must be positioned as far forward as possible.

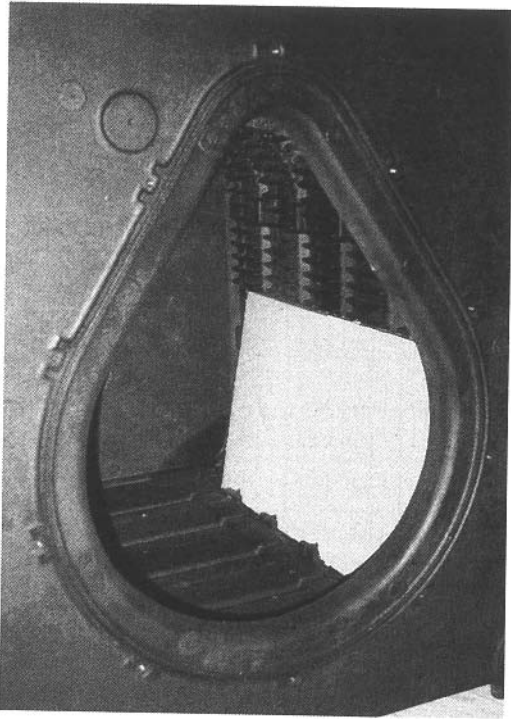

Figure 19: Firewall Plates

3. Install firewall plates using silastic (provided) on each upper and lower edge of firewall plate where plate rests against section. Apply a minimum bead of 1/2" diameter to all contact points to form a good bond to the casting.

F. JACKET ASSEMBLY

FOR V1104 thru 1112 JACKET ASSEMBLY DRAWING, SEE FIGURE 20.

FOR V1113 thru 1123 JACKET ASSEMBLY DRAWING, SEE FIGURE 21.

1. Open jacket carton(s) and jacket hardware package. Unless otherwise stated, all jacket components are fastened with #8 x 1/2" hex head sheet metal screws. Do not drive sheet metal screws tight until jacket assembly is complete.
2. Remove square knockout from jacket rear panel. To remove knockout, use a single hacksaw blade with handle or aviation snips to cut metal tabs between slotted holes.
3. Attach jacket front panel to front section and jacket rear panel to back section using the eight (8) #10 self tapping screws. Tighten these screws securely.
4. **JACKET INTERMEDIATE PANEL ATTACHMENT** - required on V1113 thru 1123 jacket assemblies only.
Use two (2) sheet metal screws each to secure jacket intermediate panels to brackets previously attached during the section assembly process. Tighten these screws securely. For bracket attachment refer to Section II, Paragraph B, Step m, item *i*.

5. Each jacket channel has a three (3) digit identification number stamped on the bottom flange. The last two (2) digits identify their nominal length. Refer to single and multiple channel usage charts, See Figures 22 and 23.
 - a. Attach each jacket 'J' channel to one of the jacket 'U' channels of equal length (last two digits match) as shown in the exploded jacket detail on each of the jacket assembly drawings.
 - b. A support bracket with adjustable leg is required on 'J'/'U' channel assemblies 46" and longer. Attach each support bracket with three (3) sheet metal screws and thread adjustable support leg (1/4" cap screw) into bottom of support bracket approximately 1" as shown in exploded jacket detail.
6. **Channel Attachment - V1104 thru 1112 Jacket Assembly** (refer to single channel usage chart, Figure 22).
 - a. Attach each 'J'/'U' channel assembly to the bottom of the front and rear jacket panels using four (4) sheet metal screws.
 - b. On 'J'/'U' channel assemblies with support bracket, adjust support leg (1/4" cap screw) down until leg touches floor, then add 1/2 to 1 full additional turn.
 - c. Attach each remaining 'U' channel to the top of the front and rear jacket panels ('U' side down) using (2) sheet metal screws.
7. **Channel Attachment - V1113 thru 1123 Jacket Assembly** (refer to multiple channel usage chart, Figure 23).
 - a. Attach the appropriate length 'J'/'U' channel assembly to the bottom of the front and intermediate jacket panels using four (4) sheet metal screws. Repeat for opposite side.
 - b. Attach remaining 'J'/'U' channel assemblies between the bottom of intermediate and rear jacket panels on each side in the same manner.
 - c. On 'J'/'U' channel assemblies with support bracket, adjust support leg (1/4" cap screw) down until leg touches floor, then add 1/2 to 1 full additional turn.
 - d. Using two (2) sheet metal screws each, attach the remaining 'U' channels ('U' side down) between the tops of the front, intermediate and rear jacket panels according to channel length.
8. Position the loose piece of 1" thick x 36" wide fiberglass insulation, provided in the canopy carton, against left side 'U' channel(s), across top of canopy and down over right side between canopy and supply piping. Remove insulation from collar on top flue outlet damper assembly, if so equipped.
9. **Jacket Top Panel Attachment**
 - a. On the top flue outlet damper assembly, remove octagon shaped knockout. To remove knockout,

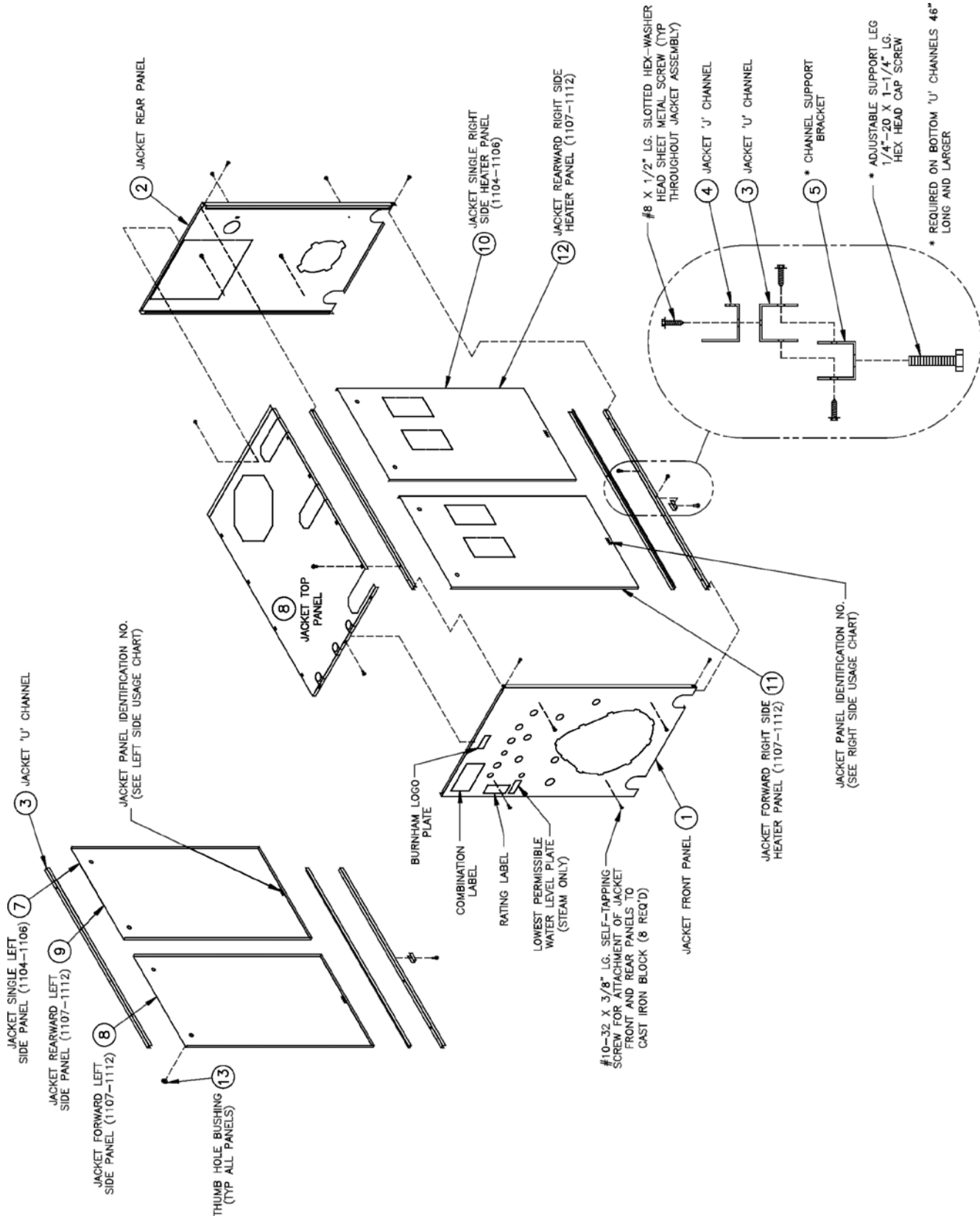

Figure 20: V11 Series Jacket Assembly (Boiler Models V1104 Thru V1112)

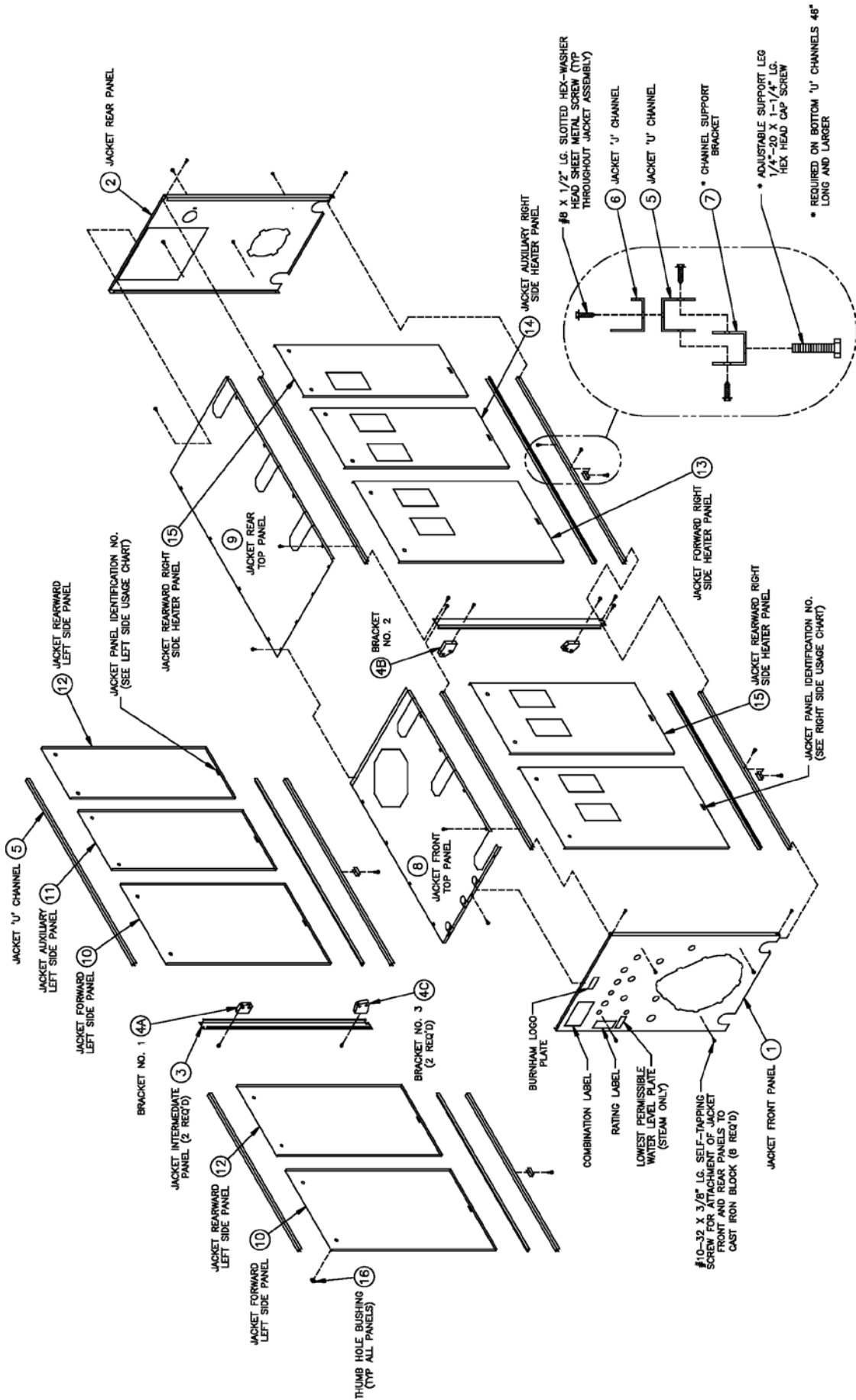

Figure 21: V11 Series Jacket Assembly (Boiler Models V1113 Thru V1123)

SINGLE CHANNEL USAGE		
Boiler Size	'U' Channel No. (4 Req'd.)	'J' Channel No. (2 Req'd.)
V1104	U26	J26
V1105	U32	J32
V1106	U38	J38
V1107	U44	J44
V1108	U50	J50
V1109	U56	J56
V1110	U63	J63
V1111	U69	J69
V1112	U75	J75

Figure 22: Single Channel Usage Chart

MULTIPLE CHANNEL USAGE				
Boiler Size	Front 'U' Channel No. (4 Req'd.)	Front 'J' Channel No. (2 Req'd.)	Rear 'U' Channel No. (4 Req'd.)	Rear 'J' Channel No. (2 Req'd.)
V1113	U46	J46	U34	J34
V1114	U46	J46	U40	J40
V1115	U46	J46	U46	J46
V1116	U52	J52	U46	J46
V1117	U52	J52	U52	J52
V1118	U52	J52	U58	J58
V1119	U65	J65	U58	J58
V1120	U65	J65	U58	J58
V1121	U65	J65	U65	J65
V1122	U65	J65	U71	J71
V1123	U65	J65	U77	J77

Figure 23: Multiple Channel Usage Chart

LEFT SIDE USAGE CHART						
Boiler Size	Single Left Side Panel	MULTIPLE SIDE PANELS (FRONT TO REAR)				
		Panel No. 1	Panel No. 2	Panel No. 3	Auxiliary Panel	Panel No. 4
		Forward Left Side Panel	Rearward Left side Panel	Forward Left side Panel	Auxiliary Left Side Panel	Rearward Left Side Panel
V1104	SLS24	---	---	---	---	---
V1105	SLS30	---	---	---	---	---
V1106	SLS36	---	---	---	---	---
V1107	---	FLS27	RLS15	---	---	---
V1108	---	FLS27	RLS21	---	---	---
V1109	---	FLS27	FLS27	---	---	---
V1110	---	FLS27	RLS33	---	---	---
V1111	---	FLS39	RLS27	---	---	---
V1112	---	FLS39	RLS33	---	---	---
V1113	---	FLS27	RLS17	FLS17	---	RLS15
V1114	---	FLS27	RLS17	FLS17	---	RLS21
V1115	---	FLS27	RLS17	FLS17	---	RLS27
V1116	---	FLS33	RLS17	FLS29	---	RLS15
V1117	---	FLS33	RLS17	FLS29	---	RLS21
V1118	---	FLS33	RLS17	FLS29	---	RLS27
V1119	---	FLS33	RLS29	FLS29	---	RLS21
V1120	---	FLS33	RLS29	FLS29	---	RLS27
V1121	---	FLS33	RLS29	FLS29	---	RLS33
V1122	---	FLS33	RLS29	FLS29	ALS24	RLS15
V1123	---	FLS33	RLS29	FLS29	ALS24	RLS21

Figure 24: Left Side Panel Usage Chart

RIGHT SIDE USAGE CHART						
Boiler Size	Single Right Side Heater Panel	MULTIPLE SIDE PANELS (FRONT TO REAR)				
		Panel No. 1	Panel No. 2	Panel No. 3	Auxiliary Panel	Panel No. 4
		Forward Right Side Heater Panel	Rearward Right Side Heater Panel	Forward Right Side Heater Panel	Auxiliary Right Side Heater Panel	Rearward Right Side Heater Panel
V1104	SRH24	---	---	---	---	---
V1105	SRH30	---	---	---	---	---
V1106	SRH36	---	---	---	---	---
V1107	---	FRH27	RRH15	---	---	---
V1108	---	FRH27	RRH21	---	---	---
V1109	---	FRH27	FRH27	---	---	---
V1110	---	FRH27	RRH33	---	---	---
V1111	---	FRH39	RRH27	---	---	---
V1112	---	FRH39	RRH33	---	---	---
V1113	---	FRH27	RRH17	FRH17	---	RRH15
V1114	---	FRH27	RRH17	FRH17	---	RRH21
V1115	---	FRH27	RRH17	FRH17	---	RRH27
V1116	---	FRH33	RRH17	FRH29	---	RRH15
V1117	---	FRH33	RRH17	FRH29	---	RRH21
V1118	---	FRH33	RRH17	FRH29	---	RRH27
V1119	---	FRH33	RRH29	FRH29	---	RRH21
V1120	---	FRH33	RRH29	FRH29	---	RRH27
V1121	---	FRH33	RRH29	FRH29	---	RRH33
V1122	---	FRH33	RRH29	FRH29	ARH24	RRH15
V1123	---	FRH33	RRH29	FRH29	ARH24	RRH21

Figure 25: Right Side Panel Usage Chart

use a single hacksaw blade with handle or aviation snips to cut metal tabs between slotted holes.

- b. Remove knockout(s) for necessary supply piping in a similar manner.
- c. Attach jacket top panel(s) to the front panel, rear panel and upper 'U' channels with sheet metal screws. Secure seam on two piece top panel (V1113-1123) with sheet metal screws.

10. Install Jacket Side Panels

- a. Snap black thumb hole bushings into all side panel holes.
- b. Use left side panel and right side panel usage charts to determine correct positions of side panels. The five (5) digit panel identification numbers shown in the charts are also stamped along the bottom edge of each panel. Refer to Figures 24 and 25.
- c. Forward and auxiliary panels have reverse bend flanges on one side of panel. These panels must be installed prior to rearward panels.
- d. If boiler is equipped with tankless heaters they should be installed at this time if they were not installed for hydrostatic test outlined on Page 20.
- e. Install left side panels into position by inserting top of panel into upper 'U' channel, pushing bottom of panel in toward boiler, and sliding panel down into bottom 'J' channel.
- f. Remove the knockouts necessary for tankless heater operation on right side panels.
- g. Install right side panels.

11. Combination Label and Burnham Logo Plate applied by manufacturer. If loose or peeling, apply pressure to reset adhesive.
12. Place the rating label (from Instruction envelope) over the top of front panel label that identifies the proper location.
13. On steam boilers, attach lowest permissible water level plate (from steam trim carton) to the front panel using sheet metal screws.
14. Tighten all sheet metal screws to complete jacket assembly.

G. MOUNT BURNER MOUNTING PLATE, refer to Figures 15 and 26.

1. Install ten (10) 5/16" x 2" long tap-end studs with the short length of threads into the boiler front section.
2. With the use of silastic, secure the 3/16" diameter rope gasket to the groove along the mounting plate opening in the front section.
3. Place burner mounting plate over studs and secure with 5/16" flat washer, lock washers and brass nuts.

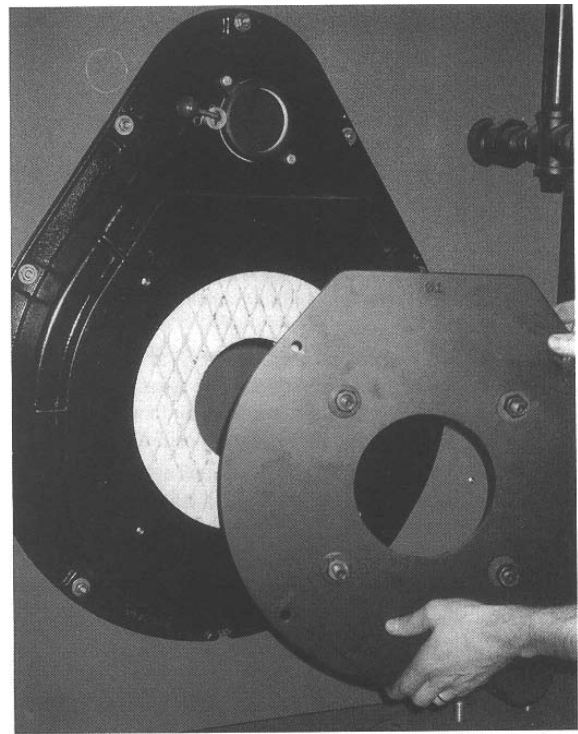
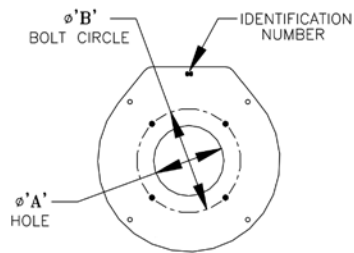
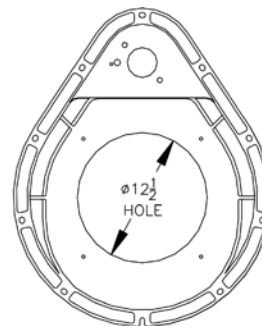

Figure 26: Burner Mounting Plate and Burner Adapter Plate

H. MOUNT BURNER ADAPTER PLATE TO BURNER MOUNTING PLATE, refer to Figures 26 and 27.



STANDARD BURNER ADAPTER PLATE



STANDARD CAST IRON BURNER MOUNTING PLATE

POWER FLAME ('C' SERIES) BURNER ADAPTER PLATE

BOILER MODEL	PART NO.	I.D. NO.	'A'	'B'
V1104 AND 1105	602263401	40	7 $\frac{1}{2}$	10 $\frac{1}{2}$
V1106 THRU 1110	602263411	41	9	12
V1111 THRU 1121	602263421	42	10 $\frac{3}{8}$	14 $\frac{1}{8}$
V1122 AND 1123	ADAPTER FURNISHED WITH BURNER			

BECKETT ('CF' SERIES) BURNER ADAPTER PLATE

BOILER MODEL	PART NO.	I.D. NO.	'A'	'B'
V1104 THRU 1109 V1112 AND 1113	602263001	00	6 $\frac{3}{4}$	10
V1110, 1111, 1114 AND 1115	602263011	01	8 $\frac{1}{4}$	10
V1116	602263021	02	10 $\frac{1}{4}$	11

POWER FLAME ('JR' SERIES) BURNER ADAPTER PLATE

BOILER MODEL	PART NO.	I.D. NO.	'A'	'B'
V1104 AND 1105	602263451	45	6 $\frac{3}{8}$	10 $\frac{1}{4}$
V1106 THRU 1108	602263461	46	8 $\frac{3}{8}$	11 $\frac{1}{16}$

BECKETT ('CG' SERIES) BURNER ADAPTER PLATE

BOILER MODEL	PART NO.	I.D. NO.	'A'	'B'
V1104 THRU 1105	602263031	03	5	10
V1106	602263041	04	6	10
V1107 THRU 1110	602263071	07	7 $\frac{1}{4}$	10
V1111 THRU 1119	602263081	08	8 $\frac{1}{8}$	11

WEBSTER ('JB' SERIES) BURNER ADAPTER PLATE

BOILER MODEL	PART NO.	I.D. NO.	'A'	'B'
V1104 THRU 1110	602263601	60	7 $\frac{7}{8}$	10 $\frac{3}{4}$
V1111 THRU 1123	602263611	61	9 $\frac{5}{8}$	12 $\frac{3}{4}$

CARLIN ('CRD/FFD' SERIES) BURNER ADAPTER PLATE

BOILER MODEL	PART NO.	I.D. NO.	'A'	'B'
V1105 THRU 1109	602263301	30	6 $\frac{1}{8}$	10
V1110 THRU 1112	602263311	31	9	10
V1114 THRU 1117	602263321	32	10 $\frac{1}{4}$	11

Figure 27: Burner Mounting Plate/Burner Adapter Plate Options

ALSO, REFER TO BURNER INSTALLATION MANUAL FOR INSTRUCTIONS SPECIFIC TO EACH BURNER.

1. In most cases the burner adapter plate carton for the specified burner will be provided by Burnham. Power Flame V1122 and V1123 burners require special adapters that will be provided with the burner.
2. If adapter is provided by Burnham, open carton and remove contents. Apply four (4) small dabs of silastic on rear surface of adapter plate to temporarily hold gasket in place. Hold adapter plate in position against burner mounting plate, align holes and secure with four (4) 3/8" lock washers and 3/8" - 16 x 7/8" lg. cap screws.
3. If adapter is furnished with burner, follow manufacturer's instructions using gasket material and hardware provided with burner.
 - a. Power Flame burners for the V1122 and V1123 are furnished with special adapter plates.
 - b. All other burners connect directly to the adapter plate supplied by Burnham.
4. USE A HOLE SAW OR KNIFE TO CUT BURNER MOUNTING PLATE INSULATION TO MATCH HOLE SIZE ON BURNER ADAPTER PLATE. After cutting, remove any and all loose pieces of insulation which may become lodged or interfere with the head of a burner air tube after insertion.
5. Confirm that hole in insulation fits snugly around burner blast tube. If hole is oversized, remove burner mounting plate (with burner attached) from boiler. Use additional fiberglass rope gasket provided with burner to fill in any space between insulation and blast tube. If additional rope gasket is not provided with the burner, use 3/8" fiberglass rope rated for 2300°F (provided by others). Reinstall burner mounting plate when finished.

CAUTION

Failure to properly fill all gaps between the insulation and burner blast tube may result in damage to the burner.

6. For boilers without tankless heaters, proceed to Paragraph I (Install Steam Trim) or J (Install Water Trim).
7. For boilers with tankless heaters, install the tankless heater manifolds according to Figure 28.

IMPORTANT

Water heater manifolds must be removable to allow for heater repair and replacement, also for the removal of jacket right side panels for boiler repair and inspection.

Therefore, the recommended use and placement of shut off valves and unions on all manifold assemblies is crucial to providing easy access for future servicing.

I. STEAM BOILERS - INSTALL STEAM TRIM

Items for steam trim are located in the steam trim carton (except for the separately ordered low cutoff and tankless heater control). Table IV and Figure 29 show the proper tappings for each item.

1. Install the gauge glass set.
2. Install the low water cutoff. When using two LWCO's on a V11 steam boiler, a probe type LWCO cannot be used in conjunction with a float type. See Figure 39 for illustration of two float LWCO's. Also follow manufacturers instructions furnished with control.
3. Install the Pressuretrol to the boiler using the 1/4" x 90° (1-7/8" x 4") siphon and the 3/4" NPT x 1/4" FPT hex bushing.
4. The Pressuretrol must be accurately leveled for proper operation. It is level when the leveling indicator hangs freely with its pointer directly over the index mark inside the back of the case. Level the controller by carefully bending the steam trap (siphon loop).
5. Install drain valve supplied by others in tapping B using the appropriate bushing
6. Install the steam gauge using the 1/2" NPT x 1/4" FPT hex bushing.
7. Install the safety valve to the back section as shown in Figure 43. The safety valve is installed in the tee provided for blowoff piping.

NOTICE

The L404 Pressure Limit contains mercury in a sealed tube. Do *not* place limit in the trash at the end of its useful life.

If this limit is replacing a limit that contains mercury in a sealed tube, do *not* place your old limit in the trash.

Contact your local waste management authority for instructions regarding recycling and the proper disposal of this limit, or of an old limit containing mercury in a sealed tube.

If you have questions, call Honeywell Inc. at 1-800-468-1502

WARNING

Safety valve discharge piping must be piped to within six (6) inches of floor or to floor drain to eliminate potential of severe burns. Do not pipe in any area where freezing could occur. Do not install any shut-off valves, plugs or caps in discharge piping.

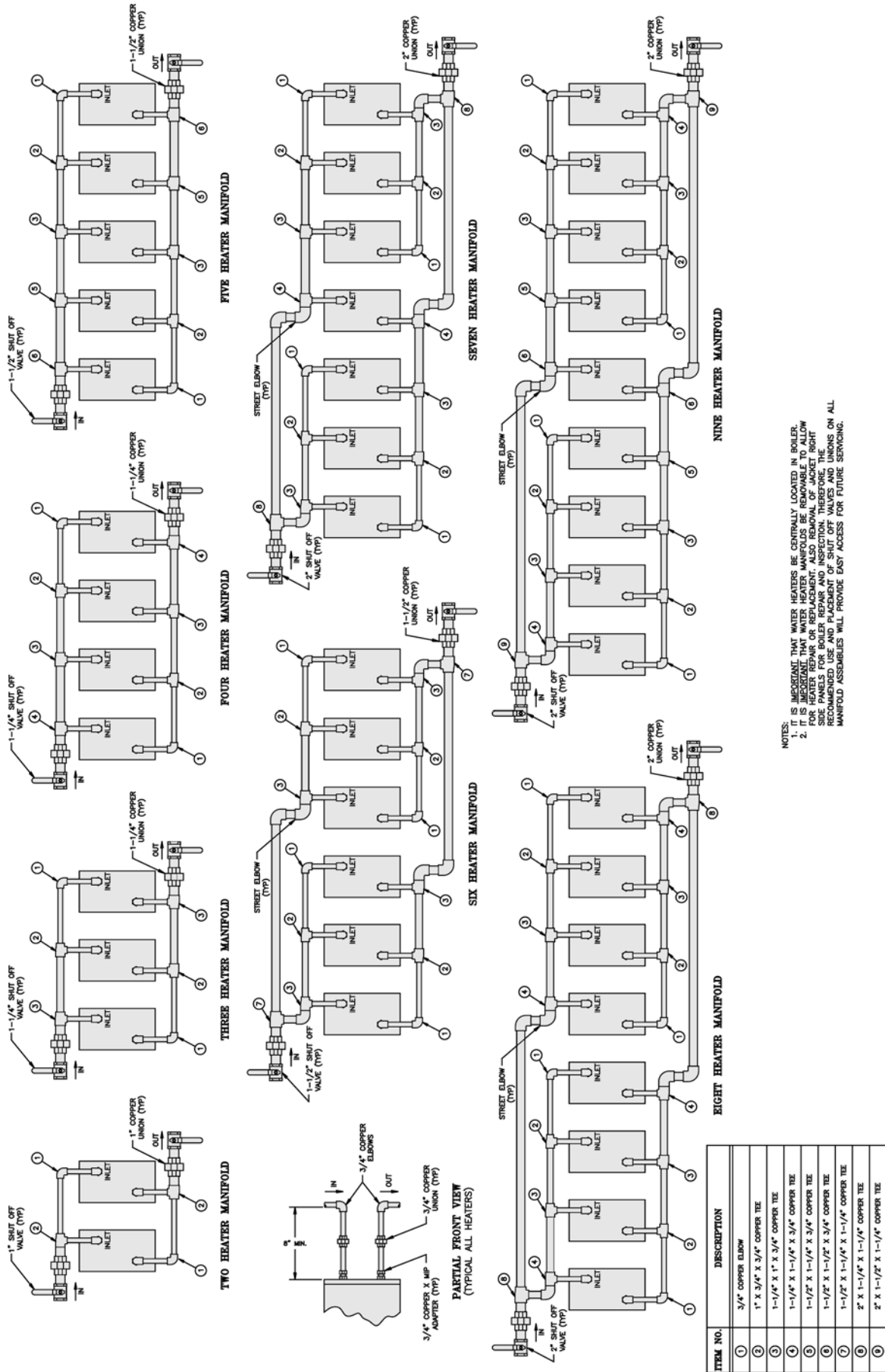

Figure 28: Minimum Piping Recommendations for V11 Series Tankless Heater Manifolds

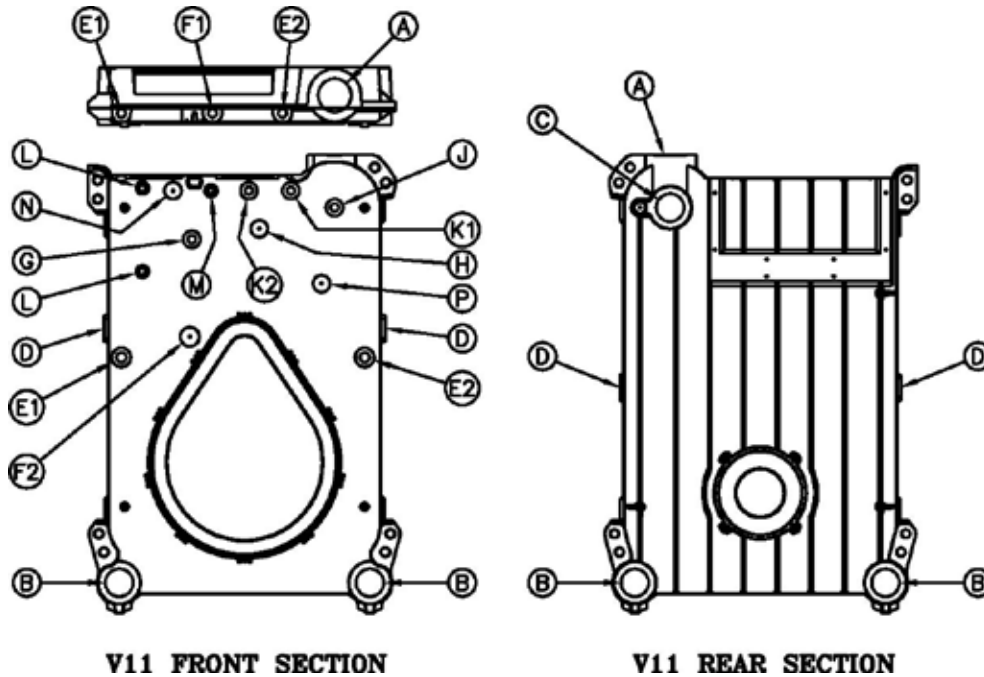

Figure 29: Purpose of Tappings

Table IV: Purpose of Tappings

TAPPING	SIZE	STEAM BOILER	WATER BOILER
A	4"	Supply	Supply
B	3"	Return	Return
C	3"	Safety Valve	Relief Valve
D	1½"	Crown Inspection / Washout *	Crown Inspection / Washout *
E1	1"	Float L.W.C.O.	Float L.W.C.O.
E2	1"	Float L.W.C.O.	Float L.W.C.O.
F1	1"	Upper Auxiliary Float L.W.C.O. Connection *	----
F2	1"	Lower Auxiliary Float L.W.C.O. Connection	----
G	¾"	----	Probe L.W.C.O.
H	¾"	----	Auxiliary Probe L.W.C.O.
J	¾"	Firing Rate Pressure Control	Firing Rate Temperature Control
K1	¾"	Operating Pressure Limit Control	Operating Temperature Limit Control
K2	¾"	High Pressure Limit Control/ Manual Reset	High Temperature Limit Control/ Manual Reset
L	½"	Gauge Glass	Not Used - Plug
M	½"	Steam Gauge (Bush to ¼")	Temperature/Pressure Gauge
N	¾"	----	Auxiliary Tapping *
P	¾"	Low Fire Hold Control	Low Fire Hold Control

* Special Order Only

8. For boilers with tankless heaters, install the operating control in an unused tapping through one of the heater plates.
9. Plug extra tappings.

J. WATER BOILERS - INSTALL WATER TRIM

Items for water trim are located in the water trim carton (except for the separately ordered low water cutoff and tankless heater control). Table IV and Figure 29 show the proper tappings for each item.

1. Install the temperature pressure gauge.
2. Install the low water cutoff. Follow manufacturers instructions furnished with controls.
3. Install the immersion well and mount the aquastat onto the well.

4. Install the drain valve supplied by others in tapping B using the appropriate bushing.
5. Install the pressure relief valve as shown in Figure 44.
6. Plug extra tappings.

K. BURNER INSTALLATION

Refer to burner manufacturer's installation manual for proper installation, fuel piping, wiring, burner adjustment and service instruction.

L. PACKAGED BOILER

1. The packaged boiler comes on its own shipping skid (see Figure 30) and the assembled block is hydrostatically tested at the factory. Once the boiler is in its final position, perform another hydrostatic test at 1½ times the working pressure of the boiler. The shipping skid can be used as a housekeeping pad unless local codes say otherwise. All controls are pre-wired down to the burner. If burner is equipped with a lead lag panel, lead lag controls will be shipped loose for header mounting. The power can be supplied to the burner if equipped with a control panel. If burner has no panel, the power is supplied to the J-box on the front jacket.
2. SUPPLY CONNECTIONS - Removal of top jacket is not required to connect the supply riser(s), however one may find it easier. Refer to Figure(s) 31 and/or 32 for water boilers and Figure 37 for steam boilers.
3. RETURN CONNECTIONS - The boiler is secured to the shipping skid with U bolts and 3" shipping nipples. REMOVE THE BOLTS AND NIPPLES. Using 3" plugs and an appropriate pipe sealant,

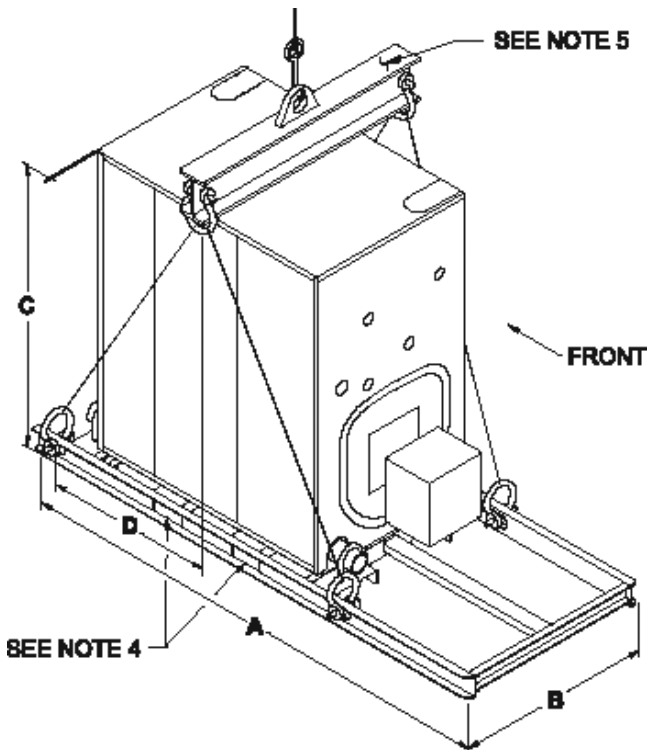

Figure 30: Shipping Information

plug the unused return connections according to the minimum piping recommendations. Refer to Figure(s) 31 and/or 32 for water boilers and Figure 37 for steam boilers.

4. If the boiler burner unit was factory fire tested, the burner was adjusted to approximately 10% CO₂ (gas) or 13% CO₂ (oil) with an overfire pressure as listed in the Burner Specifications, Section VI of this manual. Final adjustments should be made once the unit is installed and adjusted.

M. BOILER PIPING - HEATING APPLICATIONS

Connect supply and return piping to heating system (see Figures 31 to 37). Flow direction for hot water boilers must be from the rear return out through the top front supply. Steam boilers can pipe return to the front as an alternate location. Some boiler sizes may require the use of additional supply and return tapings. Check Table IV, Figure 29 and applicable piping diagram for the boiler size you are installing.

WARNING

Failure to properly pipe boiler may result in improper, unsafe system operation and void manufacturer's warranty. DO NOT improperly pipe boiler.

NOTICE

All steam and hot water pipes must have clearances of at least 1/2" from all combustible construction.

Boiler Number	Number of Sections	Length A	Width B *	Height C **	Approx. Center of Gravity D ***	Approx. Shipping Weight LBx *
V1104	4	71½	48	68	22	2438
V1105	5	77½	48	68	25½	2899
V1106	6	89½	48	68	28¼	3360
V1107	7	95½	48	68	31¼	3806
V1108	8	101¼	48	68	35	4254
V1109	9	108	48	68	38½	4689
V1110	10	114	48	68	41½	5129
V1111	11	120	48	68	44½	5597
V1112	12	130¼	48	68	47½	6029
V1113	13	136½	48	68	50¼	6537
V1114	14	142½	48	68	53¼	6880
V1115	15	148½	48	68	56¼	7408
V1116	16	154¼	48½	70	59¼	7835
V1117	17	161	48½	70	63	8265
V1118	18	167	48½	70	67	8691
V1119	19	173	48½	70	70	9140
V1120	20	179¼	48½	70	73	9567
V1121	21	185½	48½	70	76¼	10005
V1122	22	197½	48½	70	79¼	10429
V1123	23	203½	48½	70	82¼	10859

* Width can vary with gas train configuration.

** Add 6½" to dimension C when equipped with optional top outlet.

*** Varies slightly with burner and gas train configuration.

1. Do not tilt. Exercise caution when lifting to avoid damage.
2. This boiler can be lifted by fork tuck. Do not truck from front.
3. When lifting from rear, forks must extend from beyond center of gravity and second skid cross bar.
4. When lifting from side, forks must extend to opposite skid rail and straddle center of gravity.
5. Cablespreader is to prevent jacket damage. Spreader width should equal B (width of skid) + 12". Adjust cable lengths to lift at approximate center of gravity per chart.

WARNING

A hot water boiler installed above radiation level must be provided with a low water cutoff device as part of the installation.

1. HOT WATER HEATING - This boiler must be installed in strict accordance with this installation manual. Deviations from these installation instructions may void manufacturer's warranty. Also consult I=B=R Installation and Piping Guides.

WARNING

Continued boiler operation for prolonged periods of time under conditions when temperature differential across the system exceeds 40°F and/or, return water temperature stays below 135°F, may result in premature boiler failure due to flue gas condensation and/or thermal shock.

- a. If the boiler is used in connection with refrigeration systems, boiler must be installed with chilled medium piped in parallel with heating boiler using appropriate valves to prevent chilled medium from entering boiler. See Figure 40.
- b. If the boiler is connected to heating coils located in air handling units where they may be exposed to refrigerated air, boiler piping must be equipped with flow control valves to prevent gravity circulation of boiler water during cooling system operation.

- c. Burnham Commercial recommends maintaining temperature differential (drop) across the system at 40°F or less, and return water temperature at minimum of 135°F for optimum operation and long-term reliability.
 - i. If minimum return water temperature can be maintained at 135°F and temperature differential across the system is at 40°F or less, refer to Figure 31 or 32 for recommended minimum boiler piping details.
 - ii. If minimum return water temperature cannot be maintained at 135°F or the temperature differential across the system varies, a blend pump is recommended as a minimum to help protect the boiler from flue gas condensation and/or thermal shock. See piping details in Figure 33. Primary secondary piping with a by-pass is an alternate to the blend pump method and is shown in Figure 34.
- d. If conditions exist where the boiler is subjected to prolonged periods of operating conditions below 135°F, other mixing methods such as three or four way valves or variable speed injection should be used. Burnham Commercial offers an RTC Return Temperature Control kit to protect the boiler. See separate RTC manual.
- e. Multiple Boilers - Recommended minimum multiple boiler piping is shown in Figure 35 as primary secondary with a by-pass. The boiler circulator will maintain a constant flow through the boiler during every heat demand while the by-pass diverts a portion of hot water back to

the return. Alternate minimum multiple boiler piping is shown in Figure 36. The blend pump will maintain constant flow through the boiler during every heat demand and provide a hot water blend back to the return.

- f. Glycol Antifreeze Solutions - Many systems today use ethylene or propylene glycol antifreeze solutions as a measure for freeze protection, as well as a pump lubricator and corrosion inhibitor. The properties of the glycol mixture have an impact on valve and pump sizing. All glycol solutions have a lower specific heat than water. This means that the glycol solution cannot transfer heat as well as pure water, resulting in the need for higher flow rates. In addition, the viscosity of the glycol solution is usually higher than water, requiring a higher pump head for the same given flow. Consult factory for specific applications, pump selection and flow rate.

WARNING

A properly constructed Hartford Loop must be installed on all gravity return steam systems. Hartford Loop is not required on pumped return systems.

- 2. STEAM HEATING, consult I=B=R Installation and Piping Guide No. 200. For piping details, see Figure 37. Figure 38 shows a typical pumped return/boiler feed unit arrangement. Figure 39 illustrates the required elevations for McDonnell and Miller 150 and 63 float low water cut-offs.

BOILER MODEL	SUPPLY PIPING SIZE						RETURN PIPING SIZE					
	① SUPPLY		①A SUPPLY HEADER		①B SUPPLY RISER (CITY SIZE)		② RETURN		②A RETURN HEADER		②B RETURN BRANCH (CITY SIZE)	
	20°F DROP	40°F DROP	20°F DROP	40°F DROP	20°F DROP	40°F DROP	20°F DROP	40°F DROP	20°F DROP	40°F DROP	20°F DROP	40°F DROP
V1104	2 1/2"	2"	—	—	—	—	2 1/2"	2"	—	—	—	—
V1105	2 1/2"	2"	—	—	—	—	2 1/2"	2"	—	—	—	—
V1106	2 1/2"	2"	—	—	—	—	2 1/2"	2"	—	—	—	—
V1107	3"	2"	—	—	—	—	3"	2"	—	—	—	—
V1108	3"	2"	—	—	—	—	3"	2"	—	—	—	—
V1109	4"	2 1/2"	—	—	—	—	4"	2 1/2"	3"	—	(2) 3"	—
V1110	4"	2 1/2"	—	—	—	—	4"	2 1/2"	3"	—	(2) 3"	—
V1111	4"	2 1/2"	—	—	—	—	4"	2 1/2"	3"	—	(2) 3"	—
V1112	4"	3"	—	—	—	—	4"	3"	3"	—	(2) 3"	—
V1113	4"	3"	—	—	—	—	4"	3"	3"	—	(2) 3"	—
V1114	4"	3"	—	—	—	—	4"	3"	3"	—	(2) 3"	—
V1115	4"	3"	—	—	—	—	4"	3"	3"	—	(2) 3"	—
V1116	5"	3"	—	—	(2) 3"	—	5"	3"	3"	—	(2) 3"	—
V1117	5"	3"	—	—	(2) 3"	—	5"	3"	3"	—	(2) 3"	—
V1118	5"	4"	—	—	(2) 4"	—	5"	4"	4"	3"	(3) 3"	(2) 3"
V1119	5"	4"	—	—	(2) 4"	—	5"	4"	4"	3"	(3) 3"	(2) 3"
V1120	5"	4"	—	—	(2) 4"	—	5"	4"	4"	3"	(3) 3"	(2) 3"
V1121	5"	4"	—	—	(2) 4"	—	5"	4"	5"	3"	(3) 3"	(2) 3"
V1122	5"	4"	—	—	(2) 4"	—	5"	4"	5"	3"	(3) 3"	(2) 3"
V1123	5"	4"	—	—	(2) 4"	—	5"	4"	5"	3"	(3) 3"	(2) 3"

NOTES:

1. ALL PIPING IS SCHEDULE 40.
2. PIPE SIZES LISTED ARE BASED ON A 20°F OR 40°F DIFFERENCE IN TEMPERATURE DROP. SELECT ONE TO MATCH APPLICATION.
- * 3. SWING JOINT ON TWO RISER SYSTEMS MAY BE PIPED OVER THE TOP OF THE BOILER IF SPACE IS LIMITED.
4. WHEN SPECIFIED RETURN PIPING SIZE IS LESS THAN 3" INSTALL 3" X 12" NIPPLE AND APPROPRIATE SIZE BELL REDUCER DIRECTLY INTO BOILER RETURN TAPPING AS SHOWN.
5. BALL VALVE PREFERRED. GATE VALVE ACCEPTABLE ALTERNATE (SUPPLIED BY OTHERS). MINIMUM VALVE SIZE PER ASME CODE: 3/4" NPT.

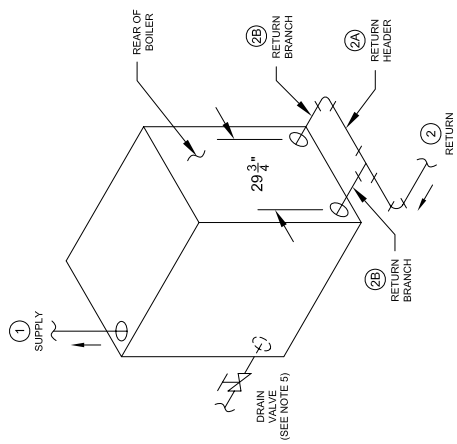

V1104 THRU V1108 (W/20°F DROP)
V1104 THRU V1117 (W/40°F DROP)

V1109 THRU V1115 (W/20°F DROP)
V1118 THRU V1123 (W/40°F DROP)

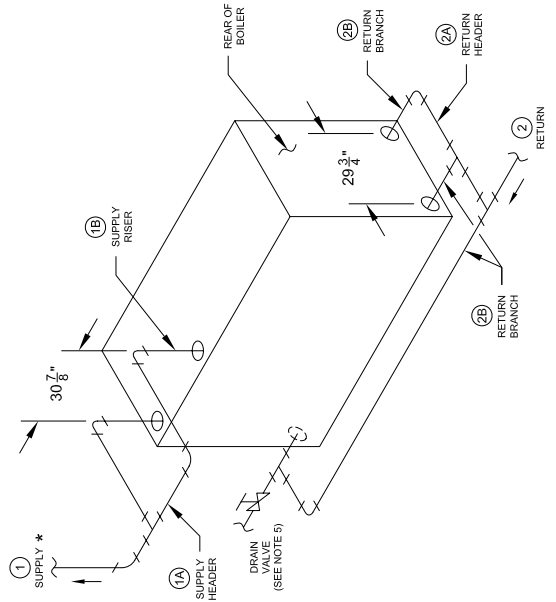

V1116 AND V1117 (W/20°F DROP)

V1118 THRU V1123 (W/20°F DROP)

Figure 31: V11 Series Minimum Piping Recommendation — Parallel — Water

BOILER MODEL	SUPPLY PIPING SIZE				RETURN PIPING SIZE							
	(1) SUPPLY		(A) SUPPLY HEADER		(B) SUPPLY RISER (QTY SIZE)		(2) RETURN		(2A) RETURN HEADER		(2B) RETURN BRANCH (QTY SIZE)	
	20°F DROP	40°F DROP	20°F DROP	40°F DROP	20°F DROP	40°F DROP	20°F DROP	40°F DROP	20°F DROP	40°F DROP	20°F DROP	40°F DROP
V1104	2 1/2"	2"	2 1/2"	2"	2 1/2"	2"	2 1/2"	2"	2 1/2"	2"	2 1/2"	2"
V1105	2 1/2"	2"	2 1/2"	2"	2 1/2"	2"	2 1/2"	2"	2 1/2"	2"	2 1/2"	2"
V1106	2 1/2"	2"	2 1/2"	2"	2 1/2"	2"	2 1/2"	2"	2 1/2"	2"	2 1/2"	2"
V1107	3"	2"	3"	2"	3"	2"	3"	2"	3"	2"	3"	2"
V1108	3"	2"	3"	2"	3"	2"	3"	2"	3"	2"	3"	2"
V1109	4"	2 1/2"	4"	2 1/2"	4"	2 1/2"	4"	2 1/2"	4"	2 1/2"	4"	2 1/2"
V1110	4"	2 1/2"	4"	2 1/2"	4"	2 1/2"	4"	2 1/2"	4"	2 1/2"	4"	2 1/2"
V1111	4"	2 1/2"	4"	2 1/2"	4"	2 1/2"	4"	2 1/2"	4"	2 1/2"	4"	2 1/2"
V1112	4"	3"	4"	3"	4"	3"	4"	3"	4"	3"	4"	3"
V1113	4"	3"	4"	3"	4"	3"	4"	3"	4"	3"	4"	3"
V1114	4"	3"	4"	3"	4"	3"	4"	3"	4"	3"	4"	3"
V1115	4"	3"	4"	3"	4"	3"	4"	3"	4"	3"	4"	3"
V1116	5"	3"	5"	3"	(2) 3"	3"	(2) 3"	3"	5"	3"	(2) 3"	3"
V1117	5"	3"	5"	3"	(2) 3"	3"	(2) 3"	3"	5"	3"	(2) 3"	3"
V1118	5"	4"	5"	4"	(2) 4"	4"	(2) 4"	4"	5"	4"	(2) 4"	4"
V1119	5"	4"	5"	4"	(2) 4"	4"	(2) 4"	4"	5"	4"	(2) 4"	4"
V1120	5"	4"	5"	4"	(2) 4"	4"	(2) 4"	4"	5"	4"	(2) 4"	4"
V1121	5"	4"	5"	4"	(2) 4"	4"	(2) 4"	4"	5"	4"	(2) 4"	4"
V1122	5"	4"	5"	4"	(2) 4"	4"	(2) 4"	4"	5"	4"	(2) 4"	4"
V1123	5"	4"	5"	4"	(2) 4"	4"	(2) 4"	4"	5"	4"	(2) 4"	4"

NOTES:

1. ALL PIPING IS SCHEDULE 40.
2. PIPE SIZES LISTED ARE BASED ON A 20°F OR 40°F DIFFERENTIAL (TEMPERATURE DROP). SELECT ONE TO WHICH APPLICATION.
3. OVER THE TOP OF THE BOILER IF SPACE IS LIMITED.
4. WHEN SPECIFIED RETURN PIPING SIZE IS LESS THAN 3" INSTALL 3" X 1/2" NIPPLE AND APPROPRIATE SIZE BELL REDUCER DIRECTLY INTO BOILER RETURN TAPPING AS SHOWN.
5. DRAIN VALVE - BALL VALVE PREFERRED. GATE VALVE ACCEPTABLE ALTERNATIVE (SUPPLIED BY OTHERS).
6. ALL PIPE REDUCTIONS SHALL BE MADE ONLY AT THE BOILER SUPPLY AND RETURN, UNLESS OTHERWISE NOTED.

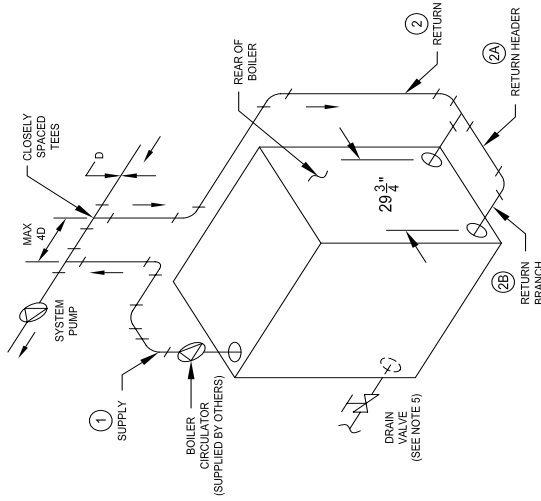

V1104 THRU V1108 (W/20°F DROP)
V1104 THRU V1117 (W/40°F DROP)

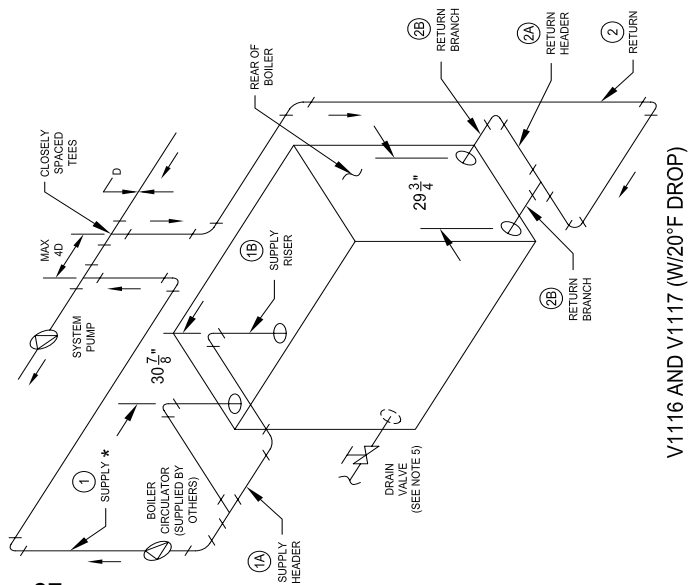
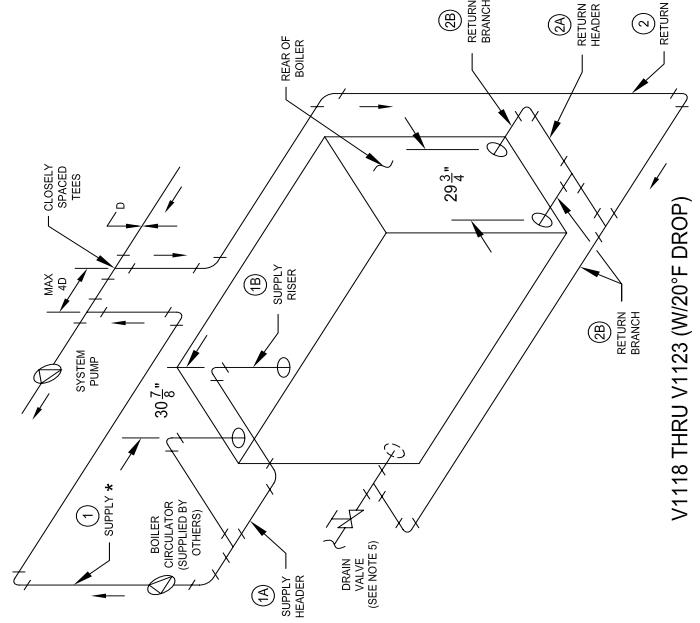
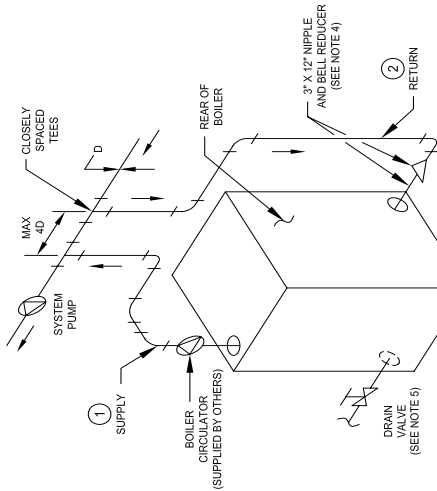
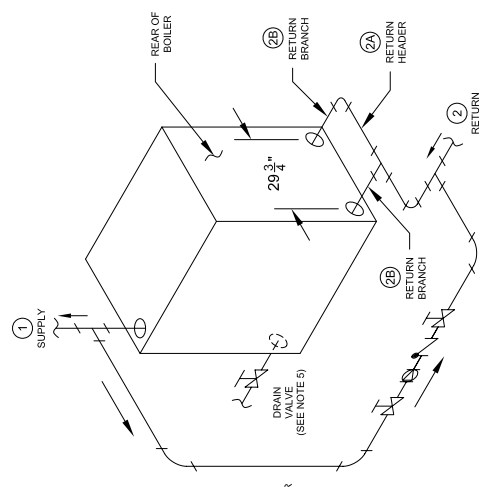

Figure 32: V11 Series Minimum Piping Recommendation — Primary Secondary — Water

BOILER MODEL	BOILER HP	GROSS OUTPUT MBH	BLEND PUMP GPM	SUPPLY PIPING SIZE						RETURN PIPING SIZE								
				1		1A		1B		2		2A		2B				
				20°F DROP	40°F DROP	20°F DROP	40°F DROP	20°F DROP	40°F DROP	20°F DROP	40°F DROP	20°F DROP	40°F DROP	20°F DROP	40°F DROP			
V1104	19.9	667	10.0	2 1/2"	2 1/2"	2 1/2"	2 1/2"	2 1/2"	2 1/2"	2 1/2"	2 1/2"	2 1/2"	2 1/2"	2 1/2"	2 1/2"	2 1/2"	2 1/2"	2 1/2"
V1105	25.6	857	12.8	2 1/2"	2 1/2"	2 1/2"	2 1/2"	2 1/2"	2 1/2"	2 1/2"	2 1/2"	2 1/2"	2 1/2"	2 1/2"	2 1/2"	2 1/2"	2 1/2"	2 1/2"
V1106	31.9	1069	16.0	2 1/2"	2 1/2"	2 1/2"	2 1/2"	2 1/2"	2 1/2"	2 1/2"	2 1/2"	2 1/2"	2 1/2"	2 1/2"	2 1/2"	2 1/2"	2 1/2"	2 1/2"
V1107	38.3	1281	19.1	3"	3"	3"	3"	3"	3"	3"	3"	3"	3"	3"	3"	3"	3"	3"
V1108	45.3	1517	22.7	3"	3"	3"	3"	3"	3"	3"	3"	3"	3"	3"	3"	3"	3"	3"
V1109	51.7	1729	25.8	4"	4"	4"	4"	4"	4"	4"	4"	4"	4"	4"	4"	4"	4"	4"
V1110	58.0	1941	29.0	4"	4"	4"	4"	4"	4"	4"	4"	4"	4"	4"	4"	4"	4"	4"
V1111	64.3	2154	32.2	4"	4"	4"	4"	4"	4"	4"	4"	4"	4"	4"	4"	4"	4"	4"
V1112	69.7	2334	34.9	4"	4"	4"	4"	4"	4"	4"	4"	4"	4"	4"	4"	4"	4"	4"
V1113	74.8	2503	37.4	4"	4"	4"	4"	4"	4"	4"	4"	4"	4"	4"	4"	4"	4"	4"
V1114	81.6	2730	40.8	4"	4"	4"	4"	4"	4"	4"	4"	4"	4"	4"	4"	4"	4"	4"
V1115	88.3	2957	44.2	4"	4"	4"	4"	4"	4"	4"	4"	4"	4"	4"	4"	4"	4"	4"
V1116	93.4	3126	46.7	5"	5"	5"	5"	5"	5"	5"	5"	5"	5"	5"	5"	5"	5"	5"
V1117	100.2	3353	50.1	5"	5"	5"	5"	5"	5"	5"	5"	5"	5"	5"	5"	5"	5"	5"
V1118	106.9	3580	53.5	5"	5"	5"	5"	5"	5"	5"	5"	5"	5"	5"	5"	5"	5"	5"
V1119	111.7	3739	55.9	5"	5"	5"	5"	5"	5"	5"	5"	5"	5"	5"	5"	5"	5"	5"
V1120	118.2	3957	59.1	5"	5"	5"	5"	5"	5"	5"	5"	5"	5"	5"	5"	5"	5"	5"
V1121	124.7	4174	62.4	5"	5"	5"	5"	5"	5"	5"	5"	5"	5"	5"	5"	5"	5"	5"
V1122	129.5	4334	64.7	5"	5"	5"	5"	5"	5"	5"	5"	5"	5"	5"	5"	5"	5"	5"
V1123	136.0	4551	68.0	5"	5"	5"	5"	5"	5"	5"	5"	5"	5"	5"	5"	5"	5"	5"

- NOTES:
1. ALL PIPING IS SCHEDULE 40.
 2. PIPE SIZES LISTED ARE BASED ON A 20°F OR 40°F DIFFERENTIAL (TEMPERATURE DROP). SELECT ONE TO MATCH APPLICATION.
 3. SUPPLY RISER SYSTEMS MAY BE PIPED OVER THE TOP OF THE BOILER IF SPACE IS LIMITED.
 4. WHEN SPECIFIED RETURN PIPING SIZE IS LESS THAN 3" INSTALL 3" X 12" NIPPLE AND APPROPRIATE SIZE BELL REDUCER DIRECTLY INTO BOILER RETURN TAPPING AS SHOWN.
 5. DRAIN VALVE - BALL VALVE PREFERRED, GATE VALVE ACCEPTABLE ALTERNATIVE (SUPPLIED BY OTHERS). MINIMUM VALVE SIZE PER ASME CODE 3" NPT.



V1109 THRU V1115 (W/20°F DROP)
V1118 THRU V1123 (W/40°F DROP)

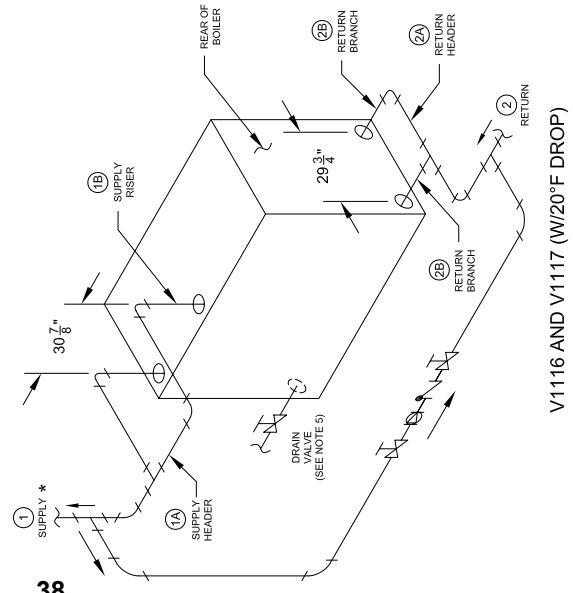

V1116 AND V1117 (W/20°F DROP)
V1118 THRU V1123 (W/20°F DROP)

Figure 33: Minimum Piping Details, Bypass With Blend Pump

BOILER MODEL	SUPPLY PIPING SIZE				RETURN PIPING SIZE							
	① SUPPLY		①A SUPPLY HEADER		①B SUPPLY RISER (PIPE SIZE)		② RETURN		②A RETURN HEADER		②B RETURN BRANCH	
	20°F DROP	40°F DROP	20°F DROP	40°F DROP	20°F DROP	40°F DROP	20°F DROP	40°F DROP	20°F DROP	40°F DROP	20°F DROP	40°F DROP
V1104	2"	2"	2"	2"	2"	2"	2"	2"	2"	2"	2"	2"
V1105	2 1/2"	2 1/2"	2 1/2"	2 1/2"	2 1/2"	2 1/2"	2 1/2"	2 1/2"	2 1/2"	2 1/2"	2 1/2"	2 1/2"
V1106	2 1/2"	2 1/2"	2 1/2"	2 1/2"	2 1/2"	2 1/2"	2 1/2"	2 1/2"	2 1/2"	2 1/2"	2 1/2"	2 1/2"
V1107	3"	3"	3"	3"	3"	3"	3"	3"	3"	3"	3"	3"
V1108	3"	3"	3"	3"	3"	3"	3"	3"	3"	3"	3"	3"
V1109	4"	2 1/2"	4"	2 1/2"	4"	2 1/2"	4"	2 1/2"	4"	2 1/2"	4"	2 1/2"
V1110	4"	2 1/2"	4"	2 1/2"	4"	2 1/2"	4"	2 1/2"	4"	2 1/2"	4"	2 1/2"
V1111	4"	2 1/2"	4"	2 1/2"	4"	2 1/2"	4"	2 1/2"	4"	2 1/2"	4"	2 1/2"
V1112	4"	3"	4"	3"	4"	3"	4"	3"	4"	3"	4"	3"
V1113	4"	3"	4"	3"	4"	3"	4"	3"	4"	3"	4"	3"
V1114	4"	3"	4"	3"	4"	3"	4"	3"	4"	3"	4"	3"
V1115	4"	3"	4"	3"	4"	3"	4"	3"	4"	3"	4"	3"
V1116	5"	3"	5"	3"	(2) 3"	5"	3"	5"	3"	(2) 3"	5"	3"
V1117	5"	3"	5"	3"	(2) 3"	5"	3"	5"	3"	(2) 3"	5"	3"
V1118	5"	4"	5"	4"	(2) 4"	5"	4"	5"	4"	(2) 4"	5"	4"
V1119	5"	4"	5"	4"	(2) 4"	5"	4"	5"	4"	(2) 4"	5"	4"
V1120	5"	4"	5"	4"	(2) 4"	5"	4"	5"	4"	(2) 4"	5"	4"
V1121	5"	4"	5"	4"	(2) 4"	5"	4"	5"	4"	(2) 4"	5"	4"
V1122	5"	4"	5"	4"	(2) 4"	5"	4"	5"	4"	(2) 4"	5"	4"
V1123	5"	4"	5"	4"	(2) 4"	5"	4"	5"	4"	(2) 4"	5"	4"

- NOTES:
- ALL PIPING IS SCHEDULE 40.
 - PIPE SIZES LISTED ARE BASED ON A 20°F OR 40°F DIFFERENTIAL (TEMPERATURE DROP). SELECT ONE TO MATCH APPLICATION.
 - SWING JOINT ON TWO RISER SYSTEMS MAY BE PIPED THROUGH THE DRAIN VALVE. THE DRAIN VALVE SHALL BE INSTALLED WITH THE DRAIN PIPING SIZE LESS THAN 3" UNLESS SPECIFIED OTHERWISE.
 - INSTALL 3" X 1/2" NIPPLE AND APPROPRIATE SIZE BELL REDUCER DIRECTLY INTO BOILER RETURN TAPPING AS SHOWN.
 - DRAIN VALVE - BALL VALVE PREFERRED, GATE VALVE ACCEPTABLE ALTERNATIVE (SUPPLIED BY OTHERS).
 - MINIMUM VALVE SIZE PER ASME CODE: 3/4" NPT.
 - ALL PIPE REDUCTIONS SHALL BE MADE ONLY AT THE BOILER SUPPLY, RETURN, VALVE AND PUMP FLANGES UNLESS OTHERWISE NOTED.

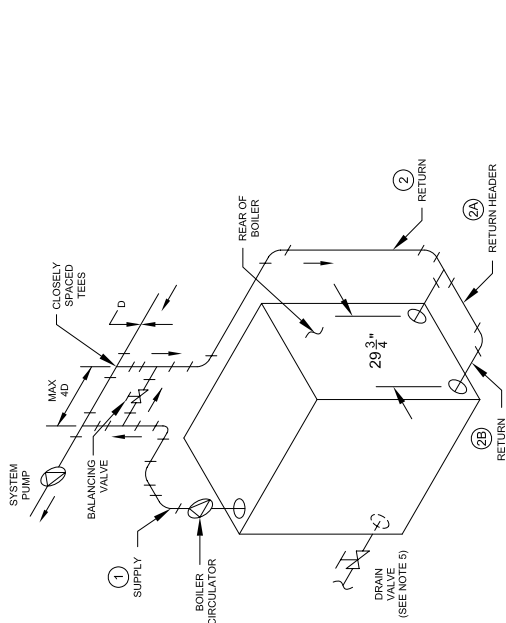

V1109 THRU V1115 (W/20°F DROP)
V1118 THRU V1123 (W/40°F DROP)

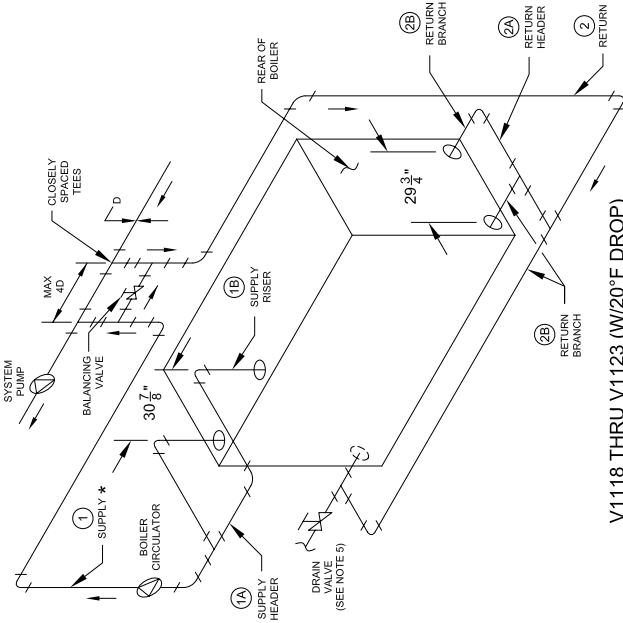

V1116 AND V1117 (W/20°F DROP)
V1118 THRU V1123 (W/20°F DROP)

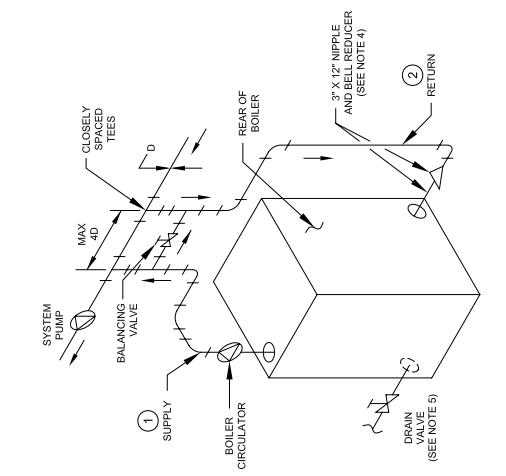

V1104 THRU V1110 (W/20°F DROP)
V1104 THRU V1117 (W/40°F DROP)

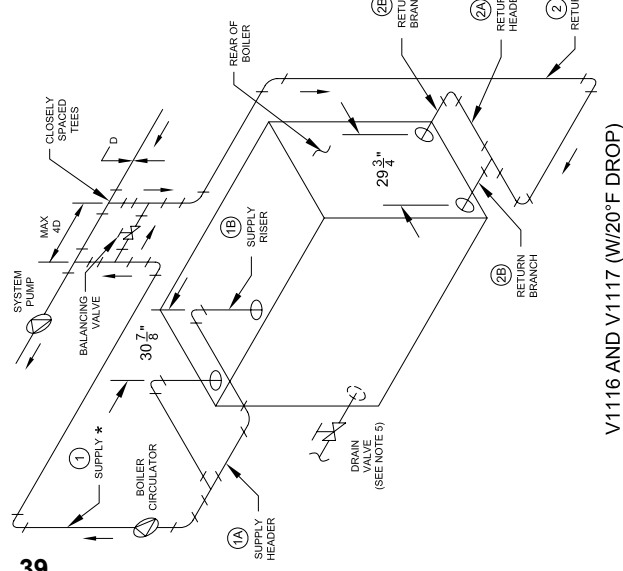

V1111 THRU V1117 (W/20°F DROP)

Figure 34: Minimum Piping Details, Primary/Secondary Piping With Bypass

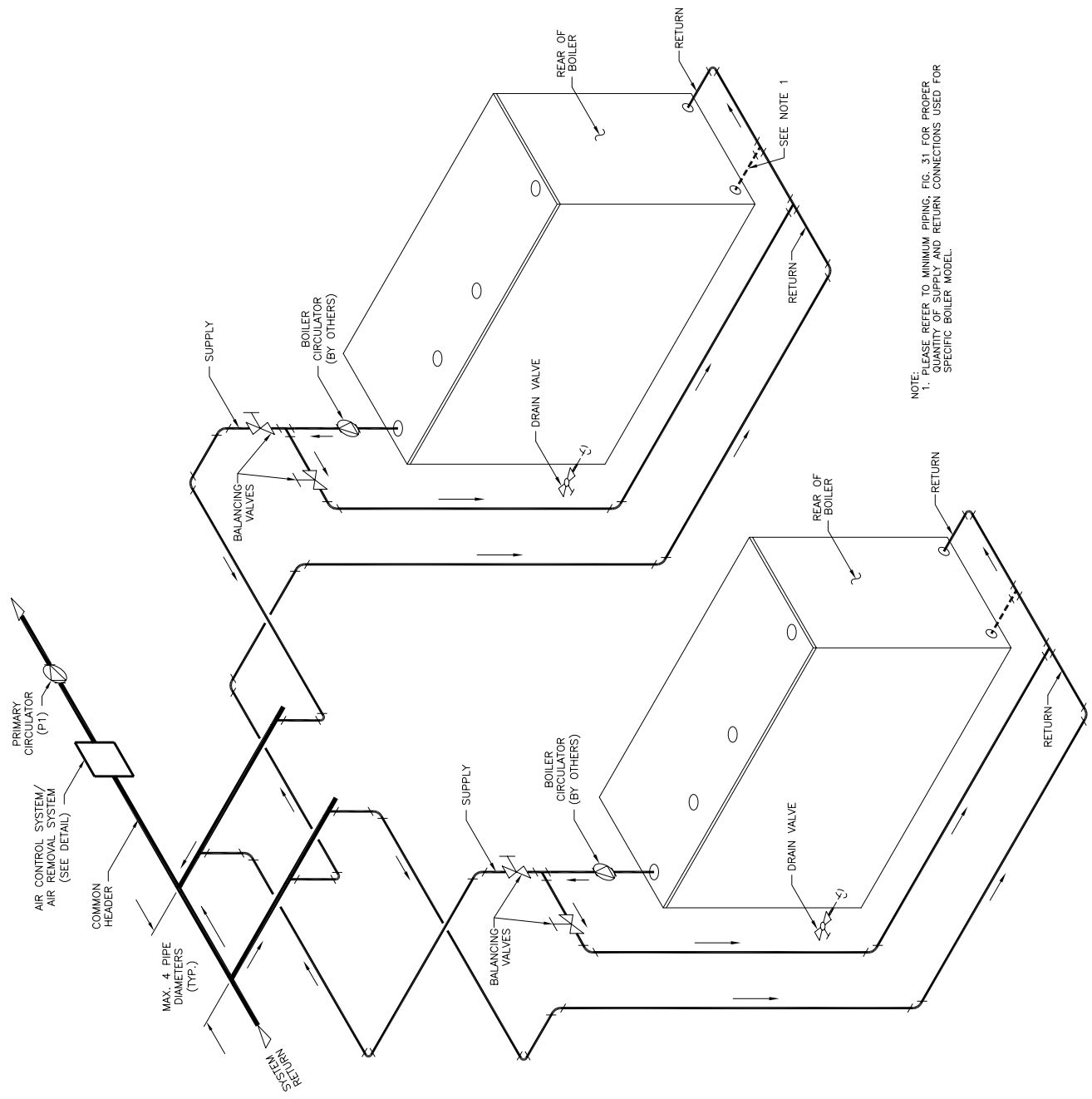

NOTE:
1. PLEASE REFER TO MINIMUM PIPING, FIG. 31 FOR PROPER
SIZES AND SUPPLY AND RETURN CONNECTIONS USED FOR
SPECIFIC BOILER MODEL.

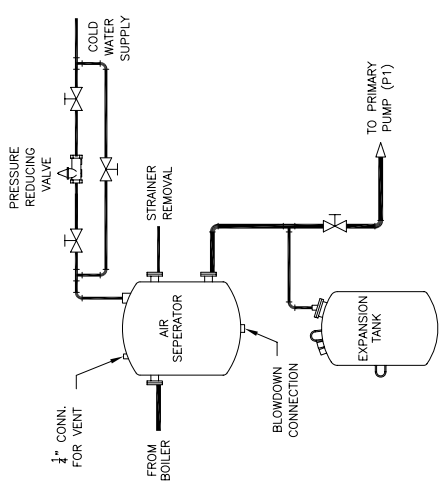

AIR REMOVAL TYPE SYSTEM W/SEPARATOR

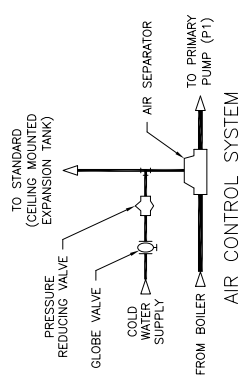

AIR REMOVAL TYPE SYSTEM W/ AIR SCOOP

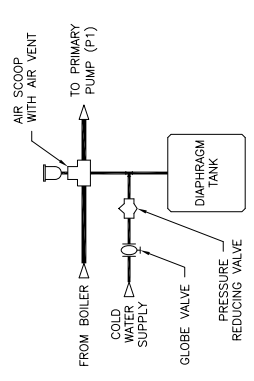

AIR REMOVAL SYSTEM W AIR SCOOP

Figure 35: Minimum Piping Details - Multiple Boiler Application, Primary/Secondary Piping With Bypass

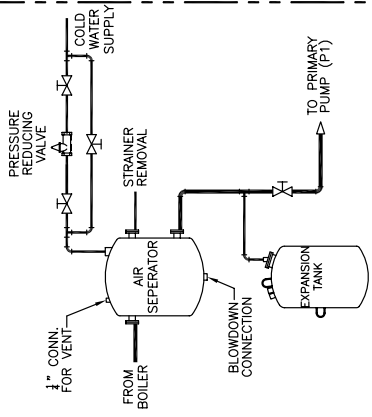
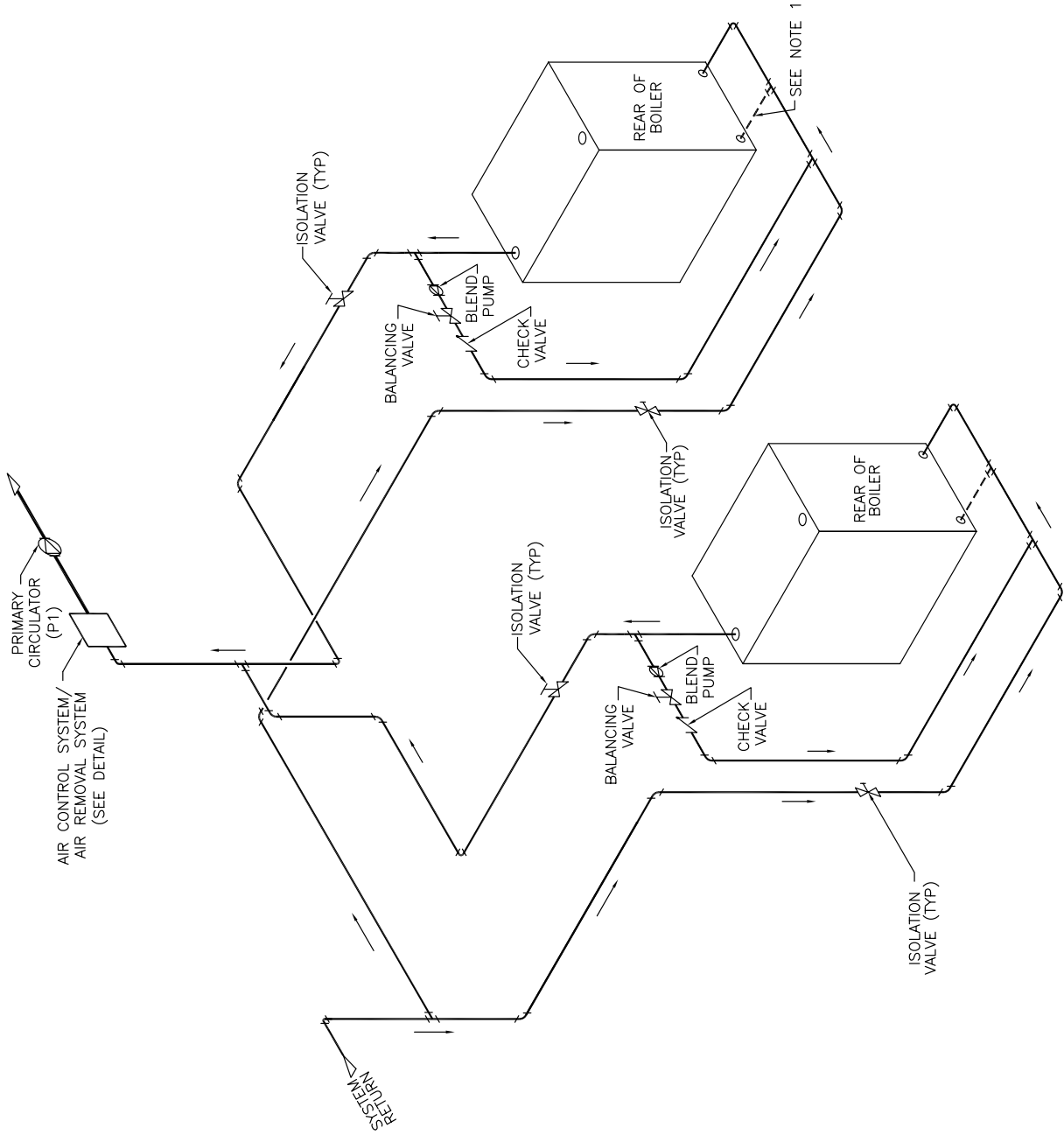

AIR REMOVAL TYPE SYSTEM W/SEPARATOR

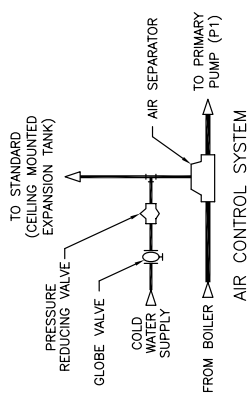

AIR CONTROL SYSTEM

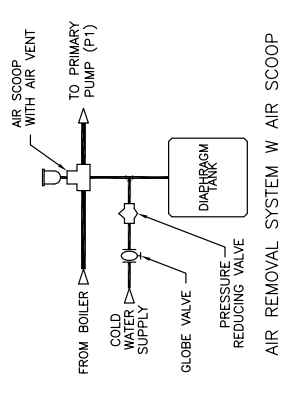

AIR REMOVAL SYSTEM W AIR SCOOP

NOTE:
 1. PLEASE REFER TO MINIMUM PIPING, FIG. 31 FOR PROPER QUANTITY OF SUPPLY AND RETURN CONNECTIONS USED FOR SPECIFIC BOILER MODEL.

Figure 36: Minimum Piping Details - Multiple Boiler Application, Parallel Piping With Blend Pump

BOILER NUMBER	PIPING SIZE			RISER SPACING						
	① RISER (QTY)	② RETURN	③ HEADER	④ EQUALIZER	⑤ BLOWOFF	'A'	'B'	'C'	'D'	'E'
V1104	(1)	4"	2"	4"	2 1/2"	1"	—	—	—	—
V1105	(1)	4"	2"	4"	2 1/2"	1"	—	—	—	—
V1106	(2)	4"	2 1/2"	6"	2 1/2"	1 1/4"	3 1 1/2"	—	—	—
V1107	(2)	4"	2 1/2"	6"	2 1/2"	1 1/4"	3 7 1/2"	—	—	—
V1108	(2)	4"	2 1/2"	6"	2 1/2"	1 1/4"	4 3 3/8"	—	—	—
V1109	(2)	4"	2 1/2"	6"	2 1/2"	1 1/4"	4 9 1/2"	—	—	—
V1110	(3)	4"	2 1/2"	6"	2 1/2"	1 1/4"	2 4 1/2"	3 6 3/8"	—	—
V1111	(3)	4"	3"	8"	4"	1 1/4"	3 7"	2 4 1/2"	—	—
V1112	(3)	4"	3"	8"	4"	1 1/4"	3 7"	3 6 3/8"	—	—
V1113	(3)	4"	3"	8"	4"	1 1/4"	3 7"	—	—	—
V1114	(4)	4"	3"	8"	4"	1 1/4"	2 4 1/2"	2 4 1/2"	3 6 3/8"	—
V1115	(4)	4"	3"	8"	4"	1 1/4"	2 4 1/2"	2 4 1/2"	3 7"	—
V1116	(4)	4"	3"	8"	4"	1 1/4"	3 0 3/8"	3 6 3/8"	2 4 1/2"	—
V1117	(4)	4"	3"	8"	4"	1 1/4"	3 0 3/8"	3 6 3/8"	3 6 3/8"	—
V1118	(5)	4"	3"	8"	4"	1 1/4"	3 0 3/8"	2 4 1/2"	2 4 1/2"	—
V1119	(5)	4"	3"	10"	4"	1 1/4"	3 0 3/8"	2 4 1/2"	2 4 1/2"	3 0 3/8"
V1120	(5)	4"	3"	10"	4"	1 1/4"	3 0 3/8"	2 4 1/2"	3 6 3/8"	2 4 1/2"
V1121	(5)	4"	3"	10"	4"	1 1/4"	3 0 3/8"	2 4 1/2"	3 6 3/8"	3 0 3/8"
V1122	(6)	4"	3"	10"	4"	1 1/4"	3 0 3/8"	2 4 1/2"	2 4 1/2"	2 4 1/2"
V1123	(6)	4"	3"	10"	4"	1 1/4"	3 0 3/8"	2 4 1/2"	2 4 1/2"	3 6 3/8"

NOTES:

- All piping is schedule 40.
- To prevent condensate from being trapped in header, do not reduce equalizer elbow at header connection.
- Ball valve preferable, gate valve acceptable alternative (supplied by others).
- Minimum valve size per ASME code is 1" NPT (V1104-1106).
- 1-1/4" NPT (V1107-1112), 1-1/2" NPT (V1113-1123).
- In all cases, piping connecting blowoff valve to boiler shall be full size to the point of discharge.
- Increasing the valve size will improve the blowdown operation
- Header piping may be run over the top of boiler if space does not allow for piping arrangement shown. Increases service requirements will result, however.
- Supply from boiler header must be connected between the first boiler riser and the header drip (or hartford loop). Do not connect supply between risers or opposite end of boiler header.

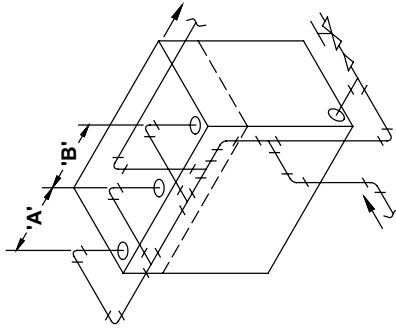

V1104 AND V1113

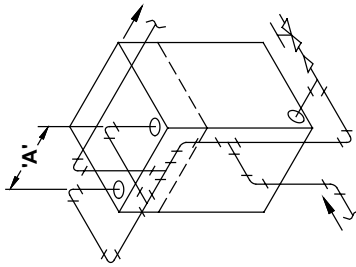

V1106 AND V1109

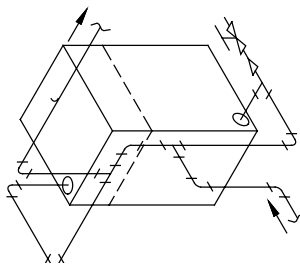

V1104 AND V1105

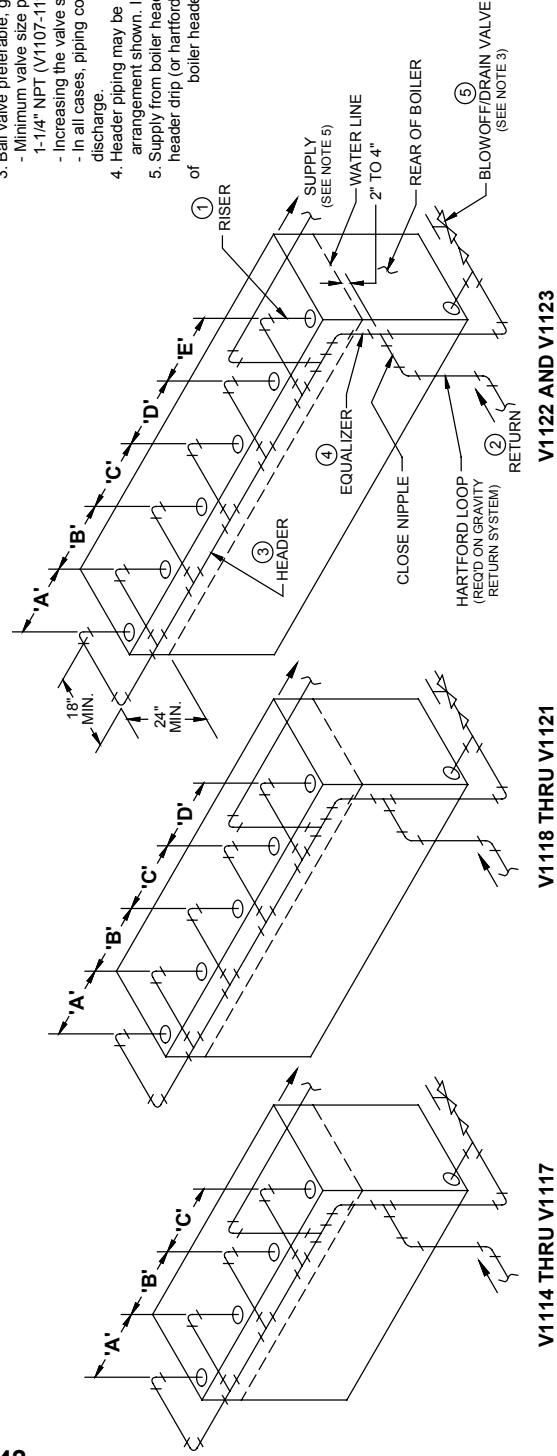

V1114 THRU V1117

V1118 THRU V1121

V1122 AND V1123

Figure 37: Minimum Piping Requirements V11 Series Steam Boilers - Gravity Return

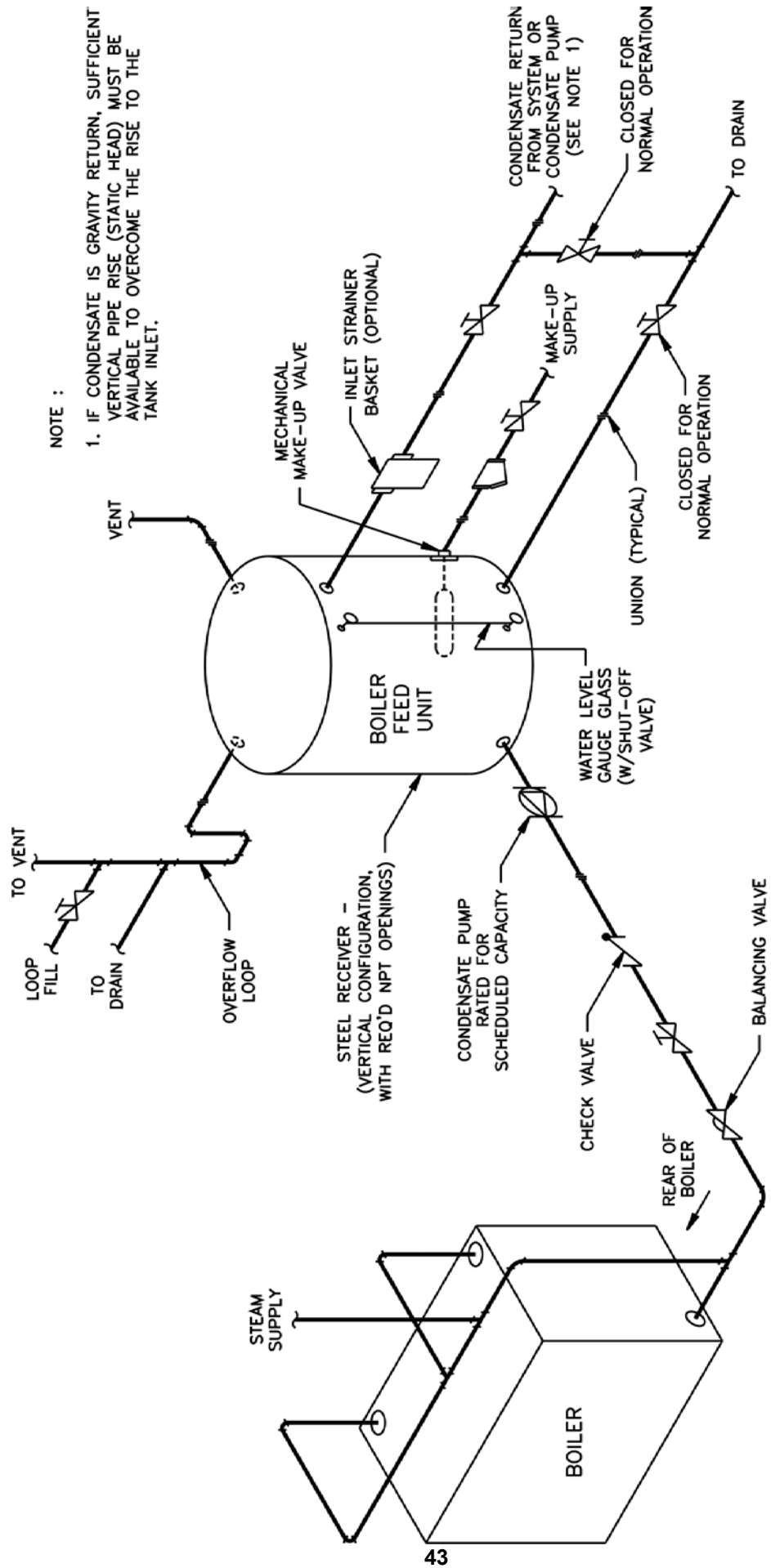

Figure 38: Typical Steam Piping Arrangement for Boilers with Pumped Condensate Return and Boiler Feed Unit

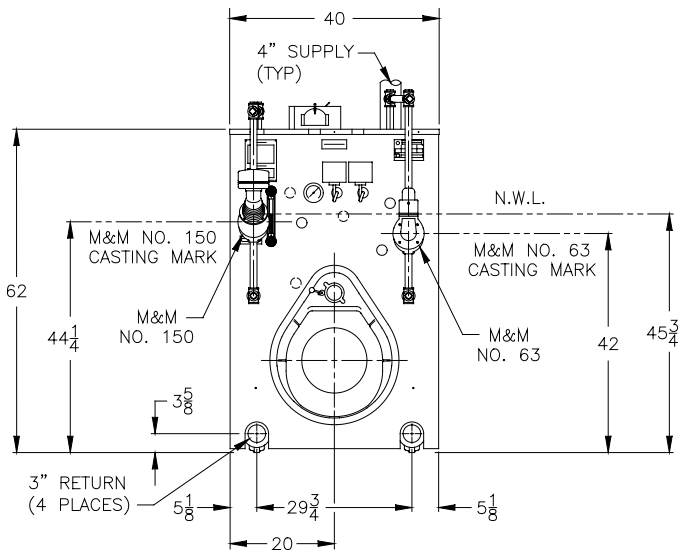

Figure 39: Mounting Elevations of M&M 150 and 63 Float Low Water Cut-offs.

N. BOILER PIPING, DOMESTIC HOT WATER (DHW) APPLICATION – The V11 boiler can be used in many different piping applications to produce Domestic Hot Water (DHW). In some applications, depending on the control strategy (outdoor reset, setpoint operation, etc.) and size of the boiler, it is recommended to isolate the space heating load from the DHW load. For example, if the domestic load is more than the space heating load, it is beneficial to dedicate one or more boilers solely to DHW production and one or more boilers solely to space heating, since during mild weather conditions, the boiler(s) will have more capacity than is required. Piped in the recommended manner, the space heating boiler(s) can be shut down during the summer months to conserve energy and to avoid short cycling. This section will address three methods of piping and controlling domestic hot water generation.

1. Hot Water Boiler/Tankless Coil(s) – Tankless coils, mounted into the side of the boiler(s), have been used successfully for many years and may be used in single and multiple boiler applications. When a boiler is arranged with tankless coils, it is not recommended that outdoor reset be used, unless there are controls in place to prevent overheating of the space heating zones. Figure 41 depicts

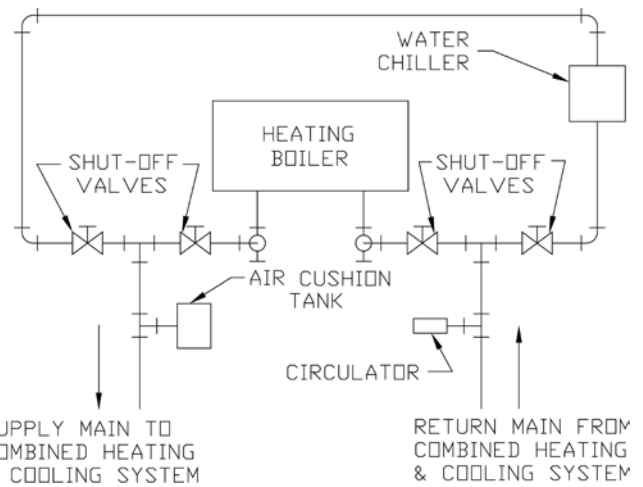

Figure 40: Recommended Piping for Combination Heating & Cooling (Refrigeration) Systems Water Boilers

the addition of an automatic mixing valve to the tankless heater piping to obtain a dual temperature domestic system. The mixing valve provides tempered water to the fixtures, while the branch prior to the valve provides high temperature water for dishwashing, washing machines and other appliances.

2. Hot Water Boiler/Tankless Coils/Storage Tank – This application involves the use of several tankless coils piped in parallel, emptying into a large storage tank, and is typically used in larger DHW production applications, such as hotel showers and laundries. See Figure 42a for recommended piping and wiring details for this type of application. The tempering valve and recirculation loop are advantageous in these applications, because they provide both high temperature and tempered domestic water to the system, eliminating the need to purge and waste water until it reaches the desired temperature. In the case where the boiler is used for domestic production only, and there is no space heating involved, a destratification pump is utilized to provide flow within the boiler. This flow acts as a means of preventing the hot water from stratifying at the top of the boiler. Destratification pump flow rates are given in the table in Figure 42a.

NOTICE

When possible, domestic hot water production should utilize a dedicated boiler(s). This will allow the other boiler(s) to be shut down and isolated during the summer months. If the boiler load is shared between heating and domestic hot water, then one needs to determine if a hot water priority is required. If a priority is not selected, erratic domestic hot water production may result during the beginning and end of every heating season. Conversely, a priority for domestic hot water production may cause a significant heating zone activation delay, in an improperly balanced system. Parallel piping conversions may require isolation from the heating system to prevent system flow influence on DHW performance. Consult a qualified system heating professional to design for the proper application.

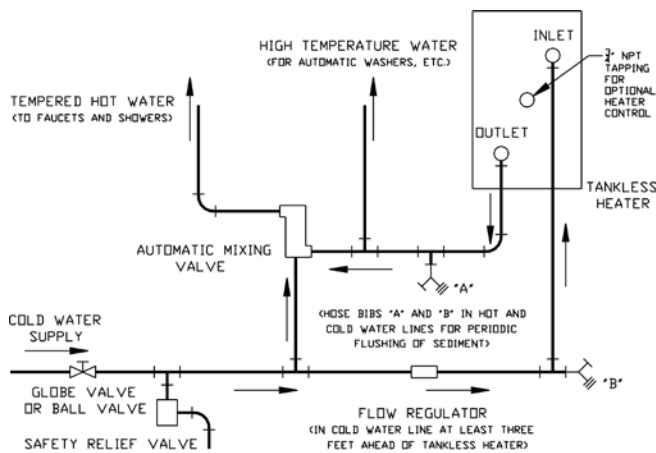

Figure 41: Schematic Tankless Heater Piping

3. Hot Water Boiler/Indirect Water Heater - The use of indirect water heaters for domestic hot water generation is common and somewhat advantageous over tankless coils alone, since they also provide DHW storage. A tempering valve and recirculating pump are again recommended for a dual temperature system, to provide a constant temperature to the fixtures without waiting for cooler water to warm up. Figure 42b shows a typical indirect heater piping application with no space heating. Indirect pump flow rates are calculated based on a 20°FΔT.

NOTICE

DO NOT use the boiler circulator as an indirect domestic hot water system circulator.

O. CONNECT TANKLESS HEATER PIPING as shown in Figure 41. See Table V for Tankless Heater Ratings.

THE FOLLOWING GUIDELINES SHOULD BE FOLLOWED WHEN PIPING THE TANKLESS HEATER:

1. Flow Regulation

If flow through the heater is greater than its rating, the supply of adequate hot water may not be able to keep up with the demand. For this reason a FLOW REGULATOR matching the heater rating should be installed in the cold waterline to the heater. Refer to Figure 41 for piping recommendations. The flow regulator should preferably be located below the inlet to the heater and a minimum of 3 feet away from the inlet so that the regulator is not subjected to excess temperatures that may occur during “off” periods when it is possible for heat to be conducted back through the supply line. The flow regulator also limits the flow of supply water regardless of inlet pressure variations in the range of 20 to 125 psi.

Table V: Tankless Heater Ratings

TANKLESS HEATER RATINGS *
(STEAM AND WATER)

BOILER MODEL	NUMBER OF V11-2 HEATERS INSTALLED								
	1	2	3	4	5	6	7	8	9
V1104	8	-	-	-	-	-	-	-	-
V1105	8	16	-	-	-	-	-	-	-
V1106	8	16	-	-	-	-	-	-	-
V1107	8	16	24	-	-	-	-	-	-
V1108	8	16	24	-	-	-	-	-	-
V1109	8	16	24	32	-	-	-	-	-
V1110	8	16	24	32	-	-	-	-	-
V1111	8	16	24	32	-	-	-	-	-
V1112	8	16	24	32	40	-	-	-	-
V1113	8	16	24	32	40	-	-	-	-
V1114	8	16	24	32	40	-	-	-	-
V1115	8	16	24	32	40	48	-	-	-
V1116	8	16	24	32	40	48	-	-	-
V1117	8	16	24	32	40	48	-	-	-
V1118	8	16	24	32	40	48	56	-	-
V1119	8	16	24	32	40	48	56	-	-
V1120	8	16	24	32	40	48	56	64	-
V1121	8	16	24	32	40	48	56	64	-
V1122	8	16	24	32	40	48	56	64	72
V1123	8	16	24	32	40	48	56	64	72

* RATINGS ARE GIVEN IN GALLONS PER MINUTE CONTINUOUS FLOW OF WATER HEATED FROM 40°F TO 140°F WITH 200°F BOILER WATER. PRESSURE DROP THROUGH EACH COIL IS 33 PSI AT 8 GPM.

FOR TANKLESS HEATER QUANTITIES LESS THAN MAXIMUM ALLOWABLE, IT IS IMPORTANT THAT WATER HEATERS BE CENTRALLY LOCATED IN BOILER. SEE FIGURE 8 FOR APPROPRIATE LOCATIONS.

2. Tempering of Hot Water

WARNING

Install a mixing valve at the tankless heater outlet to avoid risk of burns or scalding due to excessively hot water at fixtures. Do not operate the boiler when equipped with a tankless heater unless mixing valve is operating properly.

Installation of a tempering or mixing valve will also lengthen the delivery of the available hot water by mixing some cold water with the hot. In addition, savings of hot water will be achieved since the user will not waste as much hot water while seeking water temperatures to his liking. Higher temperature hot water required by dishwashers and automatic washers is possible by piping the hot water from the heater prior to entering the mixing valve. The mixing valve should be “trapped” by installing it below the cold water inlet to heater to prevent lime formation in the valve.

3. Flushing of Heater

All water contains some sediment which settles on the inside of the coil. Consequently, the heater should be periodically backwashed. This is accomplished by installing hose bibs as illustrated in Figure 41 and allowing water at city pressure to

run into hose bib A, through the heater, and out hose bib B until the discharge is clear. The tees in which the hose bibs are located should be the same size as heater connections to minimize pressure drop.

4. **HARD WATER** - A water analysis is necessary to determine the hardness of your potable water. This is applicable to some city water and particularly to well water. An appropriate water softener should be installed based on the analysis and dealer's

recommendation. This is not only beneficial to the tankless heater but to piping and fixtures plus the many other benefits derived from soft water.

- P. INSTALL ELECTRIC WIRING** in accordance with National Electric Code and local regulations. A separate **ELECTRICAL CIRCUIT** should be run from meter with a Fused Disconnect Switch in this Circuit.

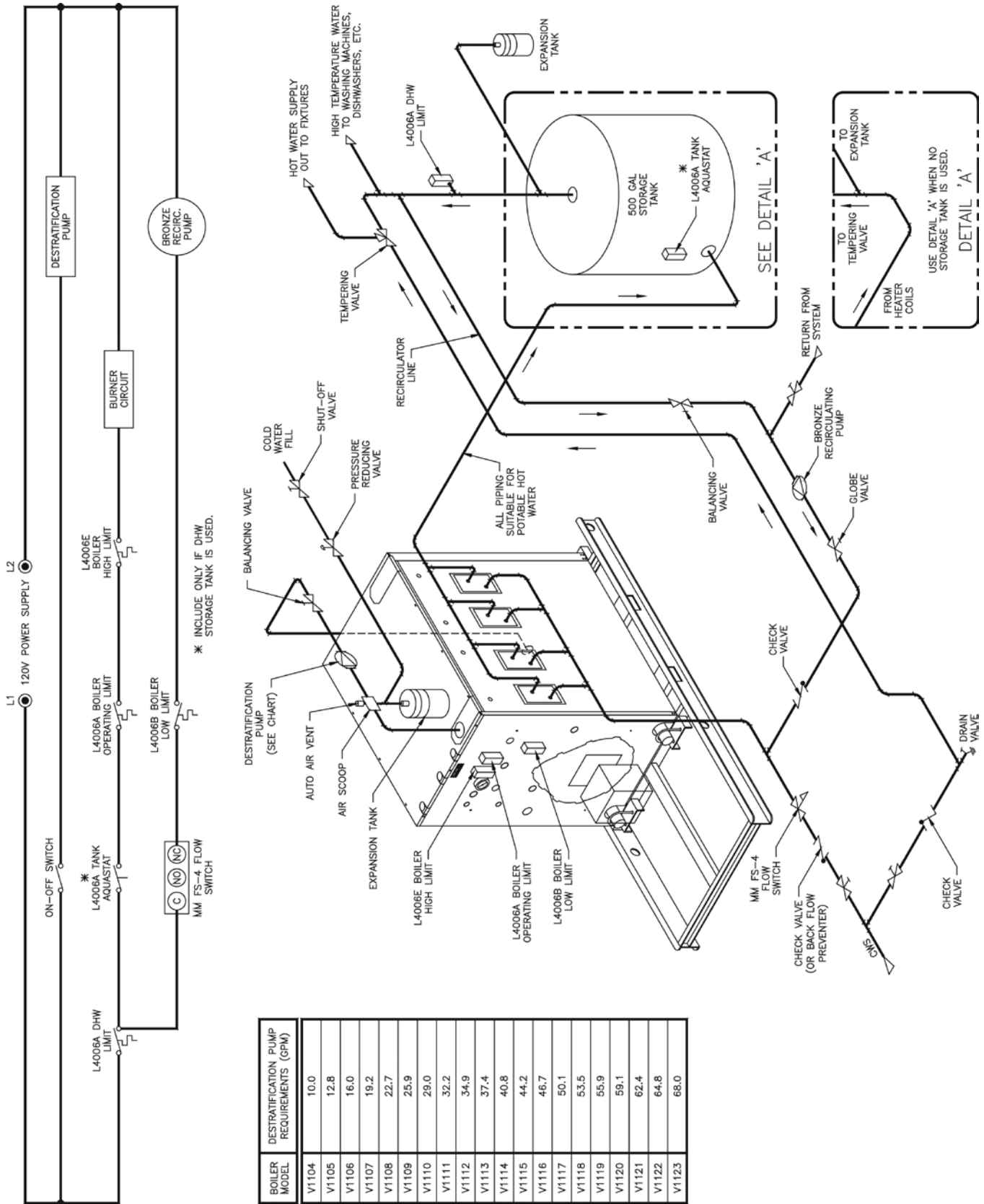

BOILER MODEL	DESTRATIFICATION PUMP REQUIREMENTS (GPM)
V1104	10.0
V1105	12.8
V1106	16.0
V1107	19.2
V1108	22.7
V1109	25.9
V1110	29.0
V1111	32.2
V1112	34.9
V1113	37.4
V1114	40.8
V1115	44.2
V1116	46.7
V1117	50.1
V1118	53.5
V1119	55.9
V1120	59.1
V1121	62.4
V1122	64.8
V1123	66.0

Figure 42a: DHW Generation with Tankless Coils, Storage Tank and Destratification Pump

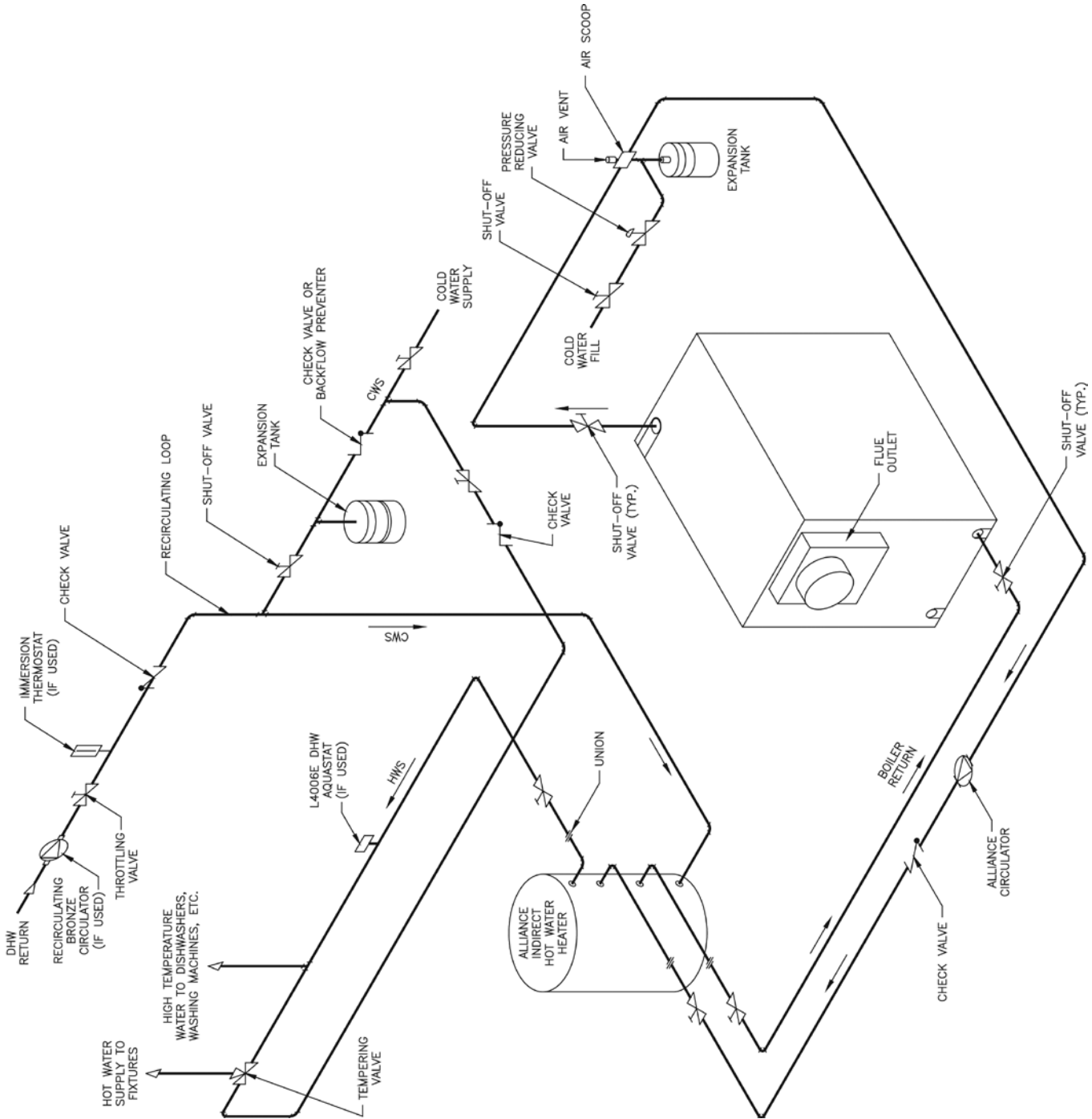

Figure 42b: DHW Generation with Indirect Water Heater

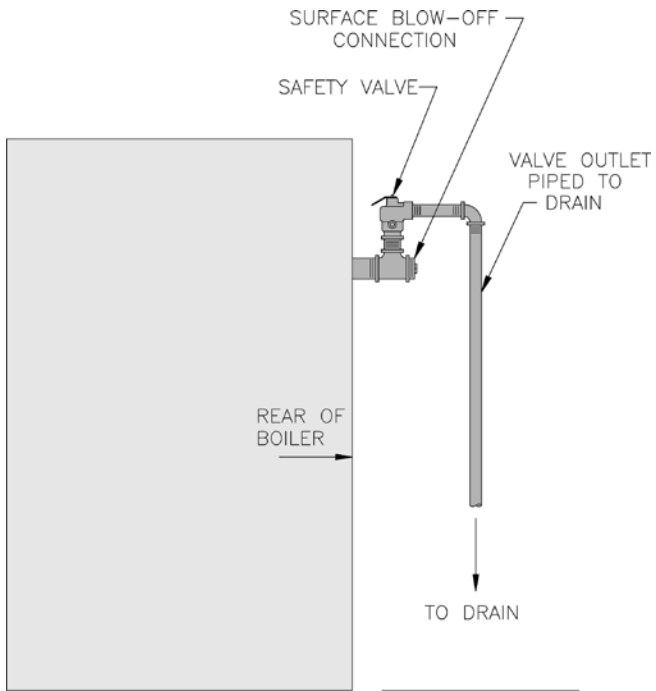

Figure 43: Steam Boiler - Safety Valve Hook-Up

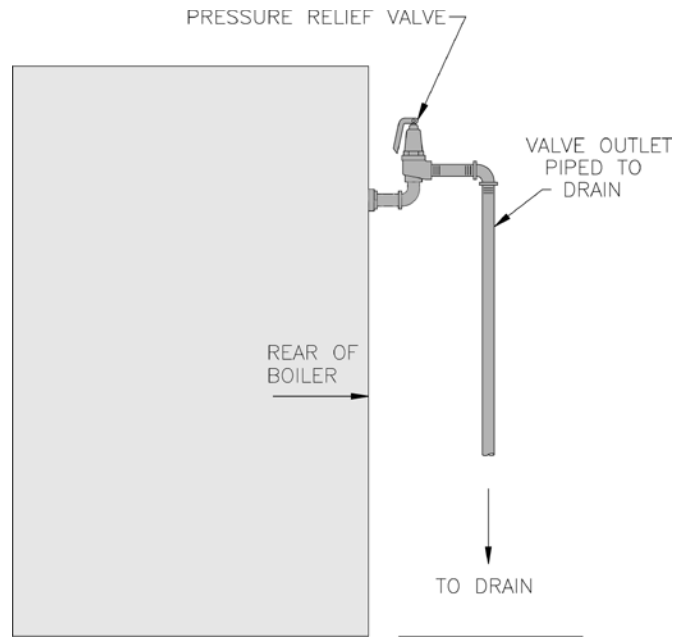

Figure 44: Water Boiler - Pressure Relief Valve Hook-Up

SECTION IV - OPERATING INSTRUCTIONS

WARNING

If you do not follow these instructions exactly, a fire or explosion may result causing property damage or personal injury.

If any unusual or improper operation or site conditions are observed, turn the boiler off and contact an experienced and skilled service agency.

Follow component manufacturer's instructions. Component manufacturer's instructions were provided with the boiler. Contact component manufacturer for replacement if instructions are missing. Do not install, start up, operate, maintain or service this boiler without reading and understanding all of the component instructions. Do not allow the boiler to operate with altered, disconnected or jumpered components. Only use replacement components identical to those originally supplied with the boiler and burner.

A. ALWAYS INSPECT INSTALLATION BEFORE STARTING BURNER.

B. FILL HEATING SYSTEM WITH WATER.

CAUTION

Failure to clean the system will result in erratic water lines and surging, and other improper system operations.

CLEAN HEATING SYSTEM IF boiler water or condensate return water is dirty or if erratic water lines or surging exist after a few days of boiler operation. Refer to Paragraph (F) for proper cleaning instructions for steam and water boilers.

1. STEAM BOILERS - Fill boiler to normal water line. As shown in Figure 1, the normal water line is 45 $\frac{3}{4}$ " from the floor. At the start of each heating season and once or twice during the season try SAFETY VALVE to be sure it is in working condition. To do this, fasten wire or cord to lever of valve and pull lever — standing safe distance away from valve.
2. HOT WATER BOILERS - Fill entire Heating System with water and vent air from system. Use the following procedure on a Series Loop or Multi-zoned System to remove air from system when filling:
 - a. Close isolation valve in boiler supply piping.
 - b. Isolate all circuits by closing zone valves or balancing valves.

- c. Attach a hose to hose bib located just below isolation valve in boiler supply piping.
(Note - Terminate hose in five gallon bucket at a suitable floor drain or outdoor area).
- d. Starting with one circuit, open zone valve.
- e. Open hose bib.
- f. Open fill valve (Make-up water line should be located directly above isolation valve in boiler supply piping).
- g. Allow water to overflow from bucket until discharge from hose is bubble free for 30 seconds.
- h. Open zone valve to the second zone to be purged, then close the first. Repeat this step until all zones have been purged, but always have one zone open. At completion, open all zone valves.
- i. Close hose bib, continue filling the system until the pressure gauge registers normal system design operating pressure. Close fill valve.
(Note - If make-up water line is equipped with pressure reducing valve, system will automatically fill to normal system design operating pressure. Leave globe valve open).
- j. Open isolation valve in boiler supply piping.
- k. Remove hose from hose bib.

DANGER

Do not operate boiler with pressure above maximum allowable working pressure listed on the Boiler Rating Label.

DO NOT draw water from boiler while in use. When adding water while boiler is in operation, do not open supply valve fully but add water slowly.

- C. SET CONTROLS with burner service switch turned "OFF".
 1. PRESS RESET BUTTON on primary control and release.
 2. On STEAM BOILERS set cutout pressure (MAIN scale) on L404 Pressuretrol for five (5) PSI and differential pressure (DIFF scale) for two (2) PSI. These pressures may be varied to suit individual requirements of installation.
 3. On STEAM BOILERS WITH TANKLESS DOMESTIC WATER HEATERS, set boiler water temperature dial on low limit operating control at 190°F (max.). Set differential at 10°.
 4. ON WATER BOILERS WITHOUT TANKLESS HEATERS, set high limit dial on L4006A at 210°F. This temperature may be varied to suit requirements of installation.

5. ON WATER BOILERS WITH TANKLESS HEATERS, set low limit operating control dial at 190°F and high limit dial 210°F. Operating control must be a minimum of 20 below high limit setting. Set differential at 25°.

D. ADJUST BURNER according to the Burner Manual.

1. FLAME FAILURE

The V11 boiler controls operate the burner automatically. If for unknown reasons the burner ceases to fire and the reset button on the primary control is tripped, the burner has experienced ignition failure. Before pressing the reset button, call your serviceman immediately.

WARNING

Do not attempt to start the burner when excess oil or gas has accumulated in the combustion chamber, when the unit is full of vapor, or when the combustion chamber is very hot.

E. TEST CONTROLS

WARNING

Before installation the boiler is considered complete, the operation of the boiler controls should be checked, particularly the low water cutoff and the high limit control.

1. CHECK OPERATING CONTROL OPERATION.
Raise and lower operating control setting as required to start and stop burner.
2. CHECK OPERATION OF HIGH LIMIT CONTROL—
Jumper Operating Control Terminals. Allow burner to operate until shutdown by limit. Installation is not considered complete until this check has been made.
REMOVE JUMPER.
3. CHECK LOW WATER CUTOFF control with water level at normal water line (see Figure 1). Raise operating control setting to allow burner to operate. Open boiler drain to allow water level to drop to bottom of sight glass until burner operation is shut down by low water cutoff.
Close boiler drain and refill to normal water line. Burner should automatically restart during fill.
RESET OPERATING CONTROL.

CAUTION

Probe and float type low water cutoff devices require annual inspection and maintenance.

Refer to Section V, Paragraph (C) for proper cleaning instructions.

4. CHECK OPERATING CONTROL on boiler equipped with tankless heaters. With burner off, draw hot water until burner starts, then turn off hot water and check burner shutdown.

F. BOILER AND SYSTEM CLEANING - STEAM BOILER

NOTICE

A qualified water treatment chemical specialist should be consulted for recommendations regarding appropriate chemical compounds and concentrations which are compatible with local environmental regulations.

WARNING

Chemicals used in treating boiler water are toxic and/or harmful. Always use protective clothing and equipment when working with/near chemicals. Contact local authorities to determine if treated boiler water can be discharged into local waste water system.

1. Oil, greases & sediments which accumulate in a new boiler and piping must be removed in order to prevent an unsteady water line and carry over of the water into the supply main above boiler. Operate the boiler with steam in the entire system for a few days allowing the condensate to return to the boiler. If the condensate can temporarily be wasted, operate boiler only for the length of time it takes for condensate to run clear. If the latter cannot be achieved or if the condensate is returned to the boiler, boil out the boiler using the SURFACE BLOWOFF connection. See Figure 43.
 - a. Drain boiler until water is just visible in gauge glass. Run temporarily 1½" pipe line from the surface blowoff connection to an open drain or some other location where hot water may be discharged safely. Do not install valve in this line.
 - b. Add an appropriate amount of recommended boilout compounds.
 - c. Start burner and operate sufficiently to boil the water without producing steam pressure. Boil for about 5 hours. Open boiler feed pipe sufficiently to permit a steady trickle of water from the surface blowoff pipe. Continue this slow boiling and trickle of overflow for several hours until the water coming from the overflow is clear.
 - d. Stop burner and drain boiler in a manner and to a location that hot water can be discharged with safety.
 - e. Refill boiler to normal water line. If water in gauge glass does not appear to be clear, repeat

steps (a. thru e.), and boil out the boiler for a longer time.

2. Low pressure steam boilers such as the V11 Series should be maintained with appropriate water treatment compounds. Add water treatment compounds as recommended by your local qualified water treatment company.
3. Remove temporary surface blowoff piping, plug tapping and reinstall safety valve. Boil or bring water temperature to 180°F promptly in order to drive off the dissolved gases in the fresh water.
4. If unsteady water line, foaming or priming persist, install gate valve in Hartford Loop and drain valves in return main and at boiler and proceed as follows:
 - a. Connect hoses from drain valves to floor drain. Close gate valve in Hartford Loop and open drain valve in return main. Fill boiler to normal water level, turn on burner and operate boiler at this water level for at least 30 minutes after the condensate begins to run hot, then turn off burner.
Close all radiator valves. Remove all supply main air valves and plug the openings in supply main.
 - b. Draw about 5 gallons of hot water from boiler into a container and dissolve into it appropriate amount of a recommended boilout compound. Remove safety valve and pour this solution into boiler, then reinstall safety valve.
 - c. Turn on burner and keep operating while feeding water to boiler slowly. This will raise water level in boiler slowly so that water will be boiling hot and will rise slowly into supply main and back through return main, flowing from drain hose at about 180°F. Continue until water runs clear from drain hose for at least 30 minutes.
 - d. Stop feeding water to boiler but continue operating burner until excess water in boiler flows out through supply main and water lowers (by steaming) until it reaches normal level in boiler. Turn off burner. Drain boiler. Open all radiator valves. Reinstall all supply main air valves. Open gate valve in Hartford Loop.
 - e. When boiler has cooled down sufficiently (crown sheet of sections are not too hot to touch), close the drain valves at boiler and in return main and feed water slowly up to normal level in boiler. Turn on burner and allow boiler to steam for 10 minutes then turn off burner. Draw off one quart of water from bottom gauge glass fitting and discard. Draw off another quart sample and if this sample is not clear, repeat the cycle of draining the boiler and return main and refilling the boiler until sample is clear.
 - f. If the boiler water becomes dirty again at a later date due to additional sediment loosened up in the piping, close gate valve in Hartford Loop,

open drain valve in return main, turn on burner and allow condensate to flow to drain until it has run clear for at least 30 minutes while feeding water to boiler so as to maintain normal water level. Turn off burner, drain boiler, open gate valve in Hartford Loop, then repeat step (a) above.

5. Make pH or Alkalinity Test.

After boiler and system have been cleaned and refilled as previously described, test the pH of the water in the system. This can easily be done by drawing a small sample of boiler water and testing hydron paper which is used in the same manner as litmus paper, except it gives specific readings. A color chart on the side of the small hydron dispenser gives the reading in pH. Hydron paper is inexpensive and obtainable from any chemical supply house or through your local druggist. The pH should be higher than 7, but lower than 11. Add some appropriate water treatment chemicals, if necessary to bring the pH within the specified range.

6. Boiler is now ready to be put into service.

G. BOILER AND SYSTEM CLEANING - WATER BOILERS

1. Filling of Boiler and System --- General --- In a hot water heating system, the boiler and entire system (other than the expansion tank) must be full of water for satisfactory operation. Water should be added to the system until the boiler pressure gauge registers normal system design operating pressure. To insure that the system is full, water should come out of all air vents when opened.
2. Boiling Out of Boiler and System. The oil and grease which accumulate in a new hot water boiler can be washed out in the following manner.
 - a. Remove safety relief valve using extreme care to avoid damaging it.
 - b. Add an appropriate amount of recommended boilout compound.
 - c. Reinstall safety relief valve.
 - d. Fill the entire system with water.
 - e. Start firing the boiler.
 - f. Circulate the water through the entire system.
 - g. Vent the system, including the radiation.
 - h. Allow boiler water to reach operating temperature, if possible.
 - i. Continue to circulate the water for a few hours.
 - j. Stop firing the boiler.
 - k. Drain the system in a manner and to a location that hot water can be discharged with safety.
 - l. Remove plugs from all available returns and wash the water side of the boiler as thoroughly as possible, using a high-pressure water stream.
 - m. Refill the system with fresh water.

3. Add appropriate boiler water treatment compounds as recommended by your local qualified water treatment company.
4. Make pH or Alkalinity Test.

After boiler and system have been cleaned and refilled as previously described, test the pH of the water in the system. This can easily be done by drawing a small sample of boiler water and testing with hydrion paper which is used in the same manner as litmus paper, except it gives specific readings. A color chart on the side of the small hydrion dispenser gives the reading in pH. Hydrion paper is inexpensive and obtainable from any chemical supply house or thru your local druggist. The pH should be higher than 7 but lower than 11. Add some appropriate water treatment chemicals, if necessary to bring the pH within the specified range. With this lower level of protection, care must be exercised to eliminate all of the free oxygen in the system.

5. Boiler is now ready to be put into service.

H. FREQUENT WATER ADDITION

IMPORTANT

IF, DURING NORMAL OPERATION, IT IS NECESSARY TO ADD WATER MORE FREQUENTLY THAN ONCE A MONTH, CONSULT A QUALIFIED SERVICE TECHNICIAN TO CHECK YOUR SYSTEM FOR LEAKS.

A leaky system will increase the volume of make-up water supplied to the boiler which can significantly shorten the life of the boiler. Entrained in make-up water are dissolved minerals and oxygen. When the fresh, cool make-up water is heated in the boiler the minerals fall out as sediment and the oxygen escapes as a gas. Both can result in reduced boiler life. The accumulation of sediment can eventually isolate the water from contacting the cast iron. When this

happens the cast iron in that area gets extremely hot and eventually cracks. The presence of free oxygen in the boiler creates a corrosive atmosphere which, if the concentration becomes high enough, can corrode the cast iron through from the inside. Since neither of these failure types are the result of a casting defect the warranty does not apply. Clearly it is in everyone's best interest to prevent this type of failure. The maintenance of system integrity is the best method to achieve this.

I. OXYGEN CORROSION:

WARNING

Oxygen contamination of the boiler water will cause corrosion of iron and steel boiler components, and can lead to boiler failure. Burnham's standard warranty does not cover problems caused by oxygen contamination of boiler water or scale (lime) build-up caused by frequent addition of water.

There are many possible causes of oxygen contamination such as:

- a. Addition of excessive make-up water as a result of system leaks.
- b. Absorption through open tanks and fittings.
- c. Oxygen permeable materials in the distribution system.

In order to ensure long product life, oxygen sources should be eliminated. This can be accomplished by taking the following measures:

- a. Repairing system leaks to eliminate the need for addition of make-up water.
- b. Eliminating open tanks from the system.
- c. Eliminating and/or repairing fittings which allow oxygen absorption.
- d. Use of non-permeable materials in the distribution system.
- e. Isolating the boiler from the system water by installing a heat exchanger.

SECTION V - SERVICE INSTRUCTIONS

DANGER

This boiler used flammable gas, high voltage electricity, moving parts, and very hot water under high pressure. Assure that all gas and electric power supplies are off and that the water temperature is cool before attempting any disassembly or service.

More than one gas shut-off valve and electrical disconnect switch are used on the boiler. Assure that all gas valves and electrical disconnect switches are off before attempting any disassembly or service.

**Do not attempt any service work if gas is present in the air in the vicinity of the boiler.
Never modify, remove or tamper with any control device.**

WARNING

This boiler must only be serviced and repaired by skilled and experienced service technicians.

If any controls are replaced, they must be replaced with identical models.

Read, understand and follow all the instructions and warnings contained in all the sections of this manual.

If any electrical wires are disconnected during service, clearly label the wires and assure that the wires are reconnected properly.

NEVER operate boiler without all sight glasses and brackets in place and securely fastened and sealed. Very HOT combustion gas may cause burn injury.

Read, understand and follow all the instructions and warnings contained in ALL of the component instruction manuals.

Assure that all safety and operating controls and components are operating properly before placing the boiler back in service.

IMPORTANT - See Section IV, Paragraph (H), under Operating Instructions if it becomes necessary to add water to the boiler more frequently than once a month.

A. GENERAL - Inspection should be conducted annually. Service as frequently as specified in paragraphs below. While service or maintenance is being done, electrical power to the boiler must be "off".

B. CLEAN THE BOILER HEATING SURFACES AND FLUE at least once each year, preferably at the end of the heating season.

1. **CLEAN THE VENT SYSTEM** - Vent system should be checked annually for:
 - a. Obstructions.
 - b. Accumulations of soot.
 - c. Deterioration of vent pipe or vent accessories due to condensation or other reasons.
 - d. Proper support - no sags, particularly in horizontal runs.
 - e. Tightness of joints.Remove all accumulations of soot with wire brush and vacuum. Remove all obstructions. Replace all deteriorated parts and support properly. Seal all joints.

2. **CLEAN THE BOILER FLUEWAYS**
 - a. Remove the smokepipe.
 - b. Remove the jacket top and left side panels.
 - c. Remove the canopy being careful not to damage the cerafelt gasket.
 - d. Loosen nuts securing the flue cleanout plates and remove the plates. The insulation should be removed with the plates taking care not to damage the insulation.
 - e. Using a 1¼" diameter wire or fibre bristle brush (36" handle) to clean the flueways. Start at the top of each flueway opening and work down the pin rows using two or three horizontal strokes per row for best results.
3. **CLEAN TOP OF BOILER SECTIONS.**
Brush and vacuum the tops of the boiler sections.
4. **CLEAN THE FIREBOX**
 - a. Disconnect fuel line(s) and remove burner and burner mounting plate.
 - b. Using wire or fibre bristle brush clean crown of boiler and inside of water legs.
 - c. Inspect firewall plates for damage or deterioration. Replace as needed per instructions outlined in Section III, Paragraph (E).

5. REASSEMBLE BOILER

CAUTION

Do not start the burner unless canopy, smokepipe, burner mounting plate and all flue plates are secured in place.

- a. Install the canopy taking care to align the cerafelt strips. If strips are damaged replace as needed.
- b. Reinstall burner mounting plate to front section making sure 3/16" diameter rope gasket is in place and forms gas tight seal. If gasket is damaged, replace.
- c. Bolt burner to burner mounting plate. Inspect gasket to assure adequate seal. Replace if damaged. Connect oil line(s) and/or gas line(s).
- d. Reinstall flue plates making sure gasket on each plate is in place and forms gas tight seal. If damaged, all edges of the cleanout plates should be sealed with Silastic sealant when reinstalled until insulation can be replaced.
- e. Reinstall jacket top and left side panels.
- f. Reinstall smokepipe.

C. MAINTENANCE OF LOW WATER CUTOFF DEVICES

NOTICE

Probe and float type low water cutoff devices require annual inspection and maintenance.

1. PROBE TYPE LOW WATER CUTOFF

Although these devices are solid state in their operation, the probe is exposed to possible contamination in the boiler water and subject to fouling.

It is important to physically remove the probe from the boiler tapping annually and inspect that probe for accumulation of scale or sediment.

Follow these steps to inspect, clean and /or replace the probe:

- a. Turn off electric service to the boiler.
- b. Drain boiler water to a level below the tapping for the probe.
- c. Disconnect wiring connections between the low water cutoff control and the probe.

DANGER

Assure that the boiler is at zero pressure before removing the LWCO probe. Do not rely on the pressure gauge to indicate that the boiler is at zero pressure. Open the safety valve to relieve all internal pressure prior to proceeding. Safety valve discharge piping must be piped such that the potential for burns is eliminated.

- d. Dismount the low water cutoff control from the probe.
- e. Unscrew the probe from the boiler tapping.
- f. Inspect that portion of the probe that is exposed to the boiler water for a scale or sediment buildup.
- g. Light deposits may be removed by wiping the probe with a damp cloth. Wiping the probe with a cloth soaked in vinegar will remove more tenacious lime deposits. The most stubborn deposits may be removed from the probe by using a diluted amount (3 part of water to 1 part) of phosphoric acid (H_2PO_4).

WARNING

Exercise caution when handling phosphoric acid and follow the instructions on container label. Always use protective clothing and equipment when working with/near chemicals.

- h. Wire brushing of the probe is not recommended as the soft platinum guard ring sandwiched between the ceramic insulators may be damaged. Care must be taken not to damage this ring in any way or the useful life of the probe may be shortened.
 - i. Clean the pipe threads of the probe to remove old, hardened pipe dope and other foreign matter.
 - j. Apply a moderate amount of good quality pipe dope to the pipe threads on the probe, leaving the two end threads bare. Do not use PTFE (Teflon) tape.
 - k. Screw the probe into the boiler tapping.
 - l. Mount the low water cutoff control on the probe.
 - m. Reconnect the control to probe wiring.
 - n. Fill the boiler to its normal waterline.
 - o. Add boiler water treatment compound as needed.
 - p. Restore electric service to the boiler.
 - q. Fire burner to bring the water in the boiler to a boil to drive off free oxygen.
 - r. **BEFORE RETURNING BOILER TO SERVICE:** Follow the low water cutoff check out procedure on page 51.
- #### 2. FLOAT TYPE LOW WATER CUTOFF

During the heating season, if an external low water cutoff is on the boiler, the blow off valve should be opened once a month (use greater frequency where conditions warrant), to flush out the sediment chamber so the device will be free to function properly.

Low water cutoffs and water feeders should be dismantled annually by qualified personnel, to the extent necessary to insure freedom from obstructions and proper functioning of the working parts. Inspect connecting lines to boiler for accumulation of mud, scale, etc., and clean as required. Examine

all visible wiring for brittle or worn insulation and make sure electrical contacts are clean and that they function properly. Give special attention to solder joints on bellows and float when this type of control is used. Check float for evidence of collapse and check mercury bulb (where applicable) for mercury separation or discoloration. **DO NOT ATTEMPT TO REPAIR MECHANISMS IN THE FIELD.** Complete replacement mechanisms, including necessary gaskets and installation instructions, are available from the manufacturer.

D. CHECK BURNER AND CONTROLS at least once a year. See Section IV, Paragraph (E) under Operating Instructions for control checks. See Burner Manual for burner tests and adjustments.

E. LUBRICATE BOILER COMPONENTS according to manufacturer's instructions. Generally, this involves the oil burner and circulator. This includes the type of lubricant to use, frequency of lubrication, and points to lubricate.

F. GENERAL MAINTENANCE CONSIDERATIONS

1. Keep radiators and convectors clean.
2. If a hot water radiator is hot at the bottom but not at the top, it indicates that air has accumulated inside and should be vented. To vent radiator, hold small cup under air vent (located near top of radiator), open vent until water escapes and then close.
3. If much water is added to system, it is advisable to heat system to a high temperature and vent again. This will make less venting necessary during the winter.

4. Where an expansion tank is used, make sure that neither the tank nor its drain pipe is exposed to freezing temperatures. Never place valves in piping leading to or from expansion tank.
5. Boiler and system cleaning will help assure trouble free operation. See Section IV, Paragraphs (F and G) under Operating Instructions for procedure.

G. ATTENTION TO BOILER WHILE NOT IN OPERATION

WARNING

If boiler is not used during winter time, it must be fully drained to prevent freeze damage.

1. Spray inside surfaces with light lubricating or crankcase oil using gun with extended stem so as to reach all corners.
2. With steam boilers, at end of season add sufficient water to fill boiler to top of water column and leave it that way until fall when water should be drained again to proper level. If at this time boiler water is dirty, drain water, flush out boiler, and refill with clean water to prescribed water level.
3. Always keep the manual fuel supply valve shut off if the burner is shut down for an extended period of time.
4. To recondition the heating system in the fall season after a prolonged shut down, follow the instructions outlined in Section IV - Operating Instructions, Paragraphs (B) through (E).

SECTION VI - BURNER SPECIFICATIONS

NOTICE

V11 boiler ratings and capacities are based upon the following burners, pump pressures, nozzle sizes and manifold pressures. Refer to instructions furnished with burner for additional information regarding proper installation, fuel piping, wiring details, burner adjustments, service instructions and burner start-up.

Table VIa: Beckett Oil Burner Specifications

Boiler Model	Burner Input (GPH)	Burner Mfr.	Burner Model	Air Tube Comb.	Burner Settings			Pump Pressure (PSI)		Nozzle Make	Nozzle Data GPH x Angle - Type
					Head	Low Fire Air or Shutter	High Fire Air or Band	Low Fire	High Fire		
V1104	5.8	Beckett	CF1400	CG66KD	0	2.5	5.0	150	300	Hago	3.50 x 45° - P
V1105	7.4	Beckett	CF1400	CF66KE	0	3.0	5.0	150	300	Hago	4.50 x 45° - P
V1106	9.2	Beckett	CF1400	CF66KE	2	3.0	6.0	150	300	Hago	4.50 x 45° - P
V1107	11.0	Beckett	CF2300A	CF66KG	2	3.0	6.0	150	300	Hago	6.50 x 45° - P
V1108	13.0	Beckett	CF2300A	CF66KG	4	3.5	6.0	150	300	Hago	7.50 x 45° - P
V1109	14.8	Beckett	CF2300A	CF66KG	4	3.5	7.5	150	300	Hago	8.50 x 45° - P
V1110	16.6	Beckett	CF2300A	CF44KS	4	3.0	5.5	150	300	Hago	9.50 x 45° - P
V1111	18.4	Beckett	CF2300A	CF66KS	6	4.0	6.0	150	300	Hago	10.50 x 45° - P
V1112	20.0	Beckett	CF2500	CF66KP	4	1.5	4.5	300	300	Hago	(L) 5.50 x 45° - P (H) 5.50 x 45° - P
V1113	21.5	Beckett	CF2500	CF66KP	5	1.0	5.5	300	300	Hago	(L) 6.00 x 45° - P (H) 6.00 x 45° - P
V1114	23.5	Beckett	CF3500A	CF80KH	2	2.0	8.0	300	300	Hago	(L) 6.50 x 45° - P (H) 6.50 x 45° - P
V1115	25.5	Beckett	CF3500A	CF80KM	3	1.5	9.0	300	300	Hago	(L) 7.00 x 45° - P (H) 7.00 x 45° - P
V1116	27.0	Beckett	CF3500A	CF114KR	6	2.5	8.5	300	300	Hago	(L) 7.50 x 45° - P (H) 7.50 x 45° - P

Table VIb: Beckett Gas Burner Specifications

Boiler Model	Burner Input (MBH)	Burner Mfr.	Burner Model	Damper Settings				Manifold Pressure - "WC		Minimum Inlet Pressure - "WC
				Low Fire	High Fire	Shutter	Band	Low Fire (Start)	High Fire	
V1104	837	Beckett	CG10.6S	---	---	8	1	(1)	3.3	4.53
V1105	1068	Beckett	CG10.6S	---	---	10	5	(1)	4.75	6.51
V1106	1328	Beckett	CG15.4S	25	67	---	---	1.15	3.55	6.16
V1107	1588	Beckett	CG25.2S	12	38	---	---	0.8	3.1	5.16
V1108	1876	Beckett	CG25.3S	15	44	---	---	0.8	3.36	4.94
V1109	2136	Beckett	CG25.4S	20	53	---	---	0.8	3.32	5.11
V1110	2396	Beckett	CG25.5S	22	95	---	---	0.8	2.94	5.19
V1111	2656	Beckett	CG50.2S	9	29	---	---	0.8	2.95	5.7
V1112	2887	Beckett	CG50.3S	12	30	---	---	0.8	2.5	4.27
V1113	3103	Beckett	CG50.3S	12	32	---	---	0.8	3.4	5.62
V1114	3392	Beckett	CG50.4S	14	35	---	---	0.8	2.97	5.62
V1115	3680	Beckett	CG50.4S	14	39	---	---	0.8	2.95	6.07
V1116	3897	Beckett	CG50.5S	16	50	---	---	0.8	3.0	5.27
V1117	4186	Beckett	CG50.5S	16	65	---	---	0.8	3.44	6.06
V1118	4474	Beckett	CG50.5S	16	80	---	---	0.8	3.85	6.85
V1119	4691	Beckett	CG50.5S	16	95	---	---	0.8	3.95	7.24

Table VIIa: Power Flame Oil Burner Specifications

Boiler Model	Burner Input (GPH)	Burner Mfr.	Burner Model	Diffuser Blade Setting	Approx. Damper Settings Top/Bottom Damper		Pump Pressure (PSI)		Nozzle Make	Nozzle Data GPH x Angle - Type
					Low Fire	High Fire	Low Fire	High Fire		
V1104	5.8	Power Flame	CR1 - OS	1/4"	1/4" / 1/4"	1" / 1"	100	300	Delavan	3.5 x 90° - B
V1105	7.4	Power Flame	CR1 - OS	3/8"	1/4" / 1/4"	1" / 1"	100	300	Delavan	4.5 x 90° - B
V1106	9.2	Power Flame	CR2 - OAS	3/16"	Closed / 1/4"	3/4" / 1/4"	100	280	Delavan	5.5 x 80° - B
V1107	11.0	Power Flame	CR2 - OAS	3/16"	Closed / 1/4"	3/4" / 1/4"	100	290	Delavan	6.5 x 80° - B
V1108	13.0	Power Flame	CR2 - OAS	1/4"	Closed / 1/4"	3/4" / 1/2"	100	300	Delavan	7.5 x 80° - B
V1109	14.8	Power Flame	CR2 - OAS	3/8"	1/4" / 1/4"	1" / 1"	100	300	Delavan	8.5 x 80° - B
V1110	16.6	Power Flame	CR2 - OAS	3/8"	1/2" / 1/2"	1-1/4" / 1-1/4"	100	300	Delavan	9.5 x 70° - B
V1111	18.4	Power Flame	CR3 - O	3/8"	1/2" / 1/2"	1-3/4" / 1-1/2"	100	300	Delavan	10.0 x 80° - 33769
V1112	20.0	Power Flame	CR3 - O	1/4"	3/16" / 3/16"	1-1/4" / 1-1/4"	100	280	Delavan	12.0 x 80° - 33769
V1113	21.5	Power Flame	CR3 - O	1/4"	3/16" / 3/16"	1-1/2" / 1-1/2"	100	300	Delavan	12.0 x 80° - 33769
V1114	23.5	Power Flame	CR3 - O	1/4"	1/4" / 1/4"	1-3/4" / 1-3/4"	100	300	Delavan	16.0 x 80° - 33769
V1115	25.5	Power Flame	CR3 - O	3/8"	1/4" / 1/4"	1-7/8" / 1-7/8"	100	285	Delavan	16.0 x 80° - 33769
V1116	27.0	Power Flame	CR3 - O	3/16"	1/8" / 1/8"	1-1/4" / 1-1/4"	100	300	Delavan	16.0 x 80° - 33769
V1117	29.0	Power Flame	CR3 - O	1/4"	1/8" / 1/8"	1-1/4" / 1-1/4"	100	285	Delavan	18.0 x 80° - 33769
V1118	31.0	Power Flame	CR3 - OB	1/4"	1/8" / 1/8"	1-3/8" x / 1-3/8"	100	300	Delavan	18.0 x 80° - 33769
V1119	32.5	Power Flame	CR3 - OB	1/4"	1/4" / 1/4"	1-1/2" / 1-1/2"	100	300	Delavan	20.0 x 80° - 33769
V1120	34.5	Power Flame	CR3 - OB	3/8"	1/4" / 1/4"	1-7/8" / 1-7/8"	100	300	Delavan	20.0 x 80° - 33769
V1121	36.5	Power Flame	CR3 - OB	1/2"	1/4" / 1/4"	1-7/8" / 1-7/8"	100	300	Delavan	22.0 x 80° - 33769
V1122	38.0	Power Flame	CR4 - OA	1/4"	Closed / 1/2"	1-1/4" / 1/2"	100	300	Delavan	40.0 x 80° - 30630
V1123	40.0	Power Flame	CR4 - OA	3/8"	Closed / 1/2"	1-1/2" / 1/2"	100	300	Delavan	40.0 x 80° - 30630

Table VIIb: Power Flame Gas Burner Specifications

Boiler Model	Burner Input (MBH)	Burner Mfr.	Burner Model	Diffuser Blade Setting	Approx. Damper Settings		Approx. Nat. Gas Manifold Pressure "WC (at orifice tee)	** Minimum Inlet Pressure "WC	Side Orifice Size for Natural Gas (Inch)
					Top/Bottom Damper	High Fire			
V1104	837	Power Flame	CR1 - G - 12	1/4"	1/4" / 1/4"	1" / 1"	3.1	4.7	5/8"
V1105	1068	Power Flame	CR1 - G - 12	3/8"	1/4" / 1/4"	1" / 1"	2.2	4.8	N/A
V1106	1328	Power Flame	CR2 - G - 15	3/16"	Closed / 1/4"	3/4" / 1/4"	1.4	5.4	N/A
V1107	1588	Power Flame	CR2 - G - 15	3/16"	Closed / 1/4"	3/4" / 1/4"	2.1	6.4	1-1/16"
V1108	1876	Power Flame	CR2 - G - 15	1/4"	Closed / 1/4"	3/4" / 1/2"	1.9	7.5	N/A
V1109	2136	Power Flame	CR2 - G - 15	3/8"	1/4" / 1/4"	1" / 1"	1.3	5.6	N/A
V1110	2396	Power Flame	CR2 - G - 20A	3/8"	1/2" / 1/2"	1-1/4" / 1-1/4"	1.5	5.8	N/A
V1111	2656	Power Flame	CR3 - G - 20	3/8"	1/2" / 1/2"	1-3/4" / 1-1/2"	3.2	5.8	1-1/8"
V1112	2887	Power Flame	CR3 - G - 20	1/4"	3/16" / 3/16"	1-1/4" / 1-1/4"	2.9	6.0	1-1/4"
V1113	3103	Power Flame	CR3 - G - 20	1/4"	3/16" / 3/16"	1-1/2" / 1-1/2"	3.2	6.8	1-1/4"
V1114	3392	Power Flame	CR3 - G - 20	1/4"	1/4" / 1/4"	1-3/4" / 1-3/4"	3.1	7.4	1-3/8"
V1115	3680	Power Flame	CR3 - G - 20	3/8"	1/4" / 1/4"	1-7/8" / 1-7/8"	2.2	7.3	N/A
V1116	3897	Power Flame	CR3 - G - 25	3/16"	1/8" / 1/8"	1-1/4" / 1-1/4"	3.0	6.6	1-1/2"
V1117	4186	Power Flame	CR3 - G - 25	1/4"	1/8" / 1/8"	1-1/4" / 1-1/4"	3.0	7.1	1-5/8"
V1118	4474	Power Flame	CR3 - G - 25B	1/4"	1/8" / 1/8"	1-3/8" / 1-3/8"	3.0	7.7	1-3/4"
V1119	4691	Power Flame	CR3 - G - 25B	1/4"	1/4" / 1/4"	1-1/2" / 1-1/2"	3.0	6.5	1-7/8"
V1120	4979	Power Flame	CR3 - G - 25B	3/8"	1/4" / 1/4"	1-7/8" / 1-7/8"	3.1	7.0	2"
V1121	5268	Power Flame	CR3 - G - 25B	1/2"	1/4" / 1/4"	1-7/8" / 1-7/8"	2.7	7.0	N/A
V1122	5485	Power Flame	CR4 - G - 25	1/4"	Closed / 1/2"	1-1/4" / 1/2"	2.6	6.3	N/A
V1123	5773	Power Flame	CR4 - G - 25	3/8"	Closed / 1/2"	1-1/2" / 1/2"	2.8	6.9	N/A

** Minimum inlet pressure for UL gas trains only. Consult factory for additional information.

Table VIIc: Power Flame Combination Gas/Oil Burner Specifications *

Boiler Model	Burner Input		Burner Mfr.	Burner Model	Diffuser Blade Setting	Approx. Damper Settings Top/Bottom Damper		Approx. Nat. Gas Manifold Pressure "WC (at orifice tee)	** Minimum Inlet Pressure "WC	Side Orifice Size for Natural Gas (Inch)
	Oil (GPH)	Gas (MBH)				Low Fire	High Fire			
V1104	5.8	837	Power Flame	CR1 - GO - 12	1/4"	1/4" / 1/4"	1" / 1"	3.1	4.7	5/8"
V1105	7.4	1068	Power Flame	CR1 - GO - 12	3/8"	1/4" / 1/4"	1" / 1"	2.2	4.8	N/A
V1106	9.2	1328	Power Flame	CR2 - GO - 15	3/16"	Closed / 1/4"	3/4" / 1/4"	1.4	5.4	N/A
V1107	11.0	1588	Power Flame	CR2 - GO - 15	3/16"	Closed / 1/4"	3/4" / 1/4"	2.1	6.4	1-1/16"
V1108	13.0	1876	Power Flame	CR2 - GO - 15	1/4"	Closed / 1/4"	3/4" / 1/2"	1.9	7.5	N/A
V1109	14.8	2136	Power Flame	CR2 - GO - 15	3/8"	1/4" / 1/4"	1" / 1"	1.3	5.6	N/A
V1110	16.6	2396	Power Flame	CR2 - GO - 20A	3/8"	1/2" / 1/2"	1-1/4" / 1-1/4"	1.5	5.8	N/A
V1111	18.4	2656	Power Flame	CR3 - GO - 20	3/8"	1/2" / 1/2"	1-3/4" / 1-1/2"	3.2	5.8	1-1/8"
V1112	20.0	2887	Power Flame	CR3 - GO - 20	1/4"	3/16" / 3/16"	1-1/4" / 1-1/4"	2.9	6.0	1-1/4"
V1113	21.5	3103	Power Flame	CR3 - GO - 20	1/4"	3/16" / 3/16"	1-1/2" / 1-1/2"	3.2	6.8	1-1/4"
V1114	23.5	3392	Power Flame	CR3 - GO - 20	1/4"	1/4" / 1/4"	1-3/4" / 1-3/4"	3.1	7.4	1-3/8"
V1115	25.5	3680	Power Flame	CR3 - GO - 20	3/8"	1/4" / 1/4"	1-7/8" / 1-7/8"	2.2	7.3	N/A
V1116	27.0	3897	Power Flame	CR3 - GO - 25	3/16"	1/8" / 1/8"	1-1/4" / 1-1/4"	3.0	6.6	1-1/2"
V1117	29.0	4186	Power Flame	CR3 - GO - 25	1/4"	1/8" / 1/8"	1-1/4" / 1-1/4"	3.0	7.1	1-5/8"
V1118	31.0	4474	Power Flame	CR3 - GO - 25B	1/4"	1/8" / 1/8"	1-3/8" / 1-3/8"	3.0	7.7	1-3/4"
V1119	32.5	4691	Power Flame	CR3 - GO - 25B	1/4"	1/4" / 1/4"	1-1/2" / 1-1/2"	3.0	6.5	1-7/8"
V1120	34.5	4979	Power Flame	CR3 - GO - 25B	3/8"	1/4" / 1/4"	1-7/8" / 1-7/8"	3.1	7.0	2"
V1121	36.5	5268	Power Flame	CR3 - GO - 25B	1/2"	1/4" / 1/4"	1-7/8" / 1-7/8"	2.7	7.0	N/A
V1122	38.0	5485	Power Flame	CR4 - GO - 25	1/4"	Closed / 1/2"	1-1/4" / 1/2"	2.6	6.3	N/A
V1123	40.0	5773	Power Flame	CR4 - GO - 25	3/8"	Closed / 1/2"	1-1/2" / 1/2"	2.8	6.9	N/A

* See oil burner data for nozzle sizes and pump pressure settings.

** Minimum inlet pressure for UL gas trains only. Consult factory for additional information.

Table VIIIa: Webster Oil Burner Specifications

Boiler Model	Burner Input (GPH)	Burner Mfr.	Burner Model	Burner Settings			Air Inlet Settings		Pump Pressure (PSI)		Nozzle Make	Nozzle Data GPH x Angle - Type
				Nozzle to Diffuser	Diffuser Blade Settings	Inner Fire Cylinder	Low Fire	High Fire	Low Fire	High Fire		
V1104	5.8	Webster	JB10 - 03	1/16"	1/8"	1/4"	N/A	1/2"	N/A	280	Delavan	(2) 1.75 x 80° - B
V1105	7.4	Webster	JB10 - 03	3/8"	1/8"	1/4"	N/A	7/8"	N/A	300	Delavan	(2) 2.25 x 80° - B
V1106	9.2	Webster	JB10 - 03	1/4"	1/8"	1/4"	5/8"	7/8"	100	300	Delavan	(2) 2.70 x 80° - B
V1107	11.0	Webster	JB10 - 05	1/4"	1/8"	1/2"	3/8"	7/8"	100	300	Delavan	(2) 3.20 x 80° - B
V1108	13.0	Webster	JB10 - 05	1/4"	1/8"	3/4"	5/8"	1"	100	300	Delavan	(1) 3.50; (1) 4.00 x 80° - B
V1109	14.8	Webster	JB10 - 07	1/4"	1/8"	1/4"	1-1/16"	1"	100	271	Delavan	(2) 4.50 x 80° - B
V1110	16.6	Webster	JB10 - 07	1/4"	1/8"	1/4"	3/4"	1-1/16"	100	276	Delavan	(2) 5.00 x 80° - B
V1111	18.4	Webster	JB20 - 10	3/8"	0.015"	5/16"	7/8"	1-1/8"	100	286	Delavan	(2) 5.50 x 80° - B
V1112	20.0	Webster	JB20 - 10	3/8"	0.015"	5/16"	3/4"	1-1/4"	100	292	Delavan	(2) 6.00 x 80° - B
V1113	21.5	Webster	JB20 - 10	3/8"	0.015"	5/16"	3/4"	1-1/4"	100	287	Delavan	(2) 6.50 x 80° - B
V1114	23.5	Webster	JB20 - 10	3/8"	0.015"	5/16"	3/4"	1-1/4"	100	294	Delavan	(2) 7.00 x 80° - B
V1115	25.5	Webster	JB20 - 10	3/8"	0.015"	5/16"	1-1/8"	1-3/4"	100	300	Delavan	(2) 7.50 x 80° - B
V1116	27.0	Webster	JB20 - 15	5/16"	0.015"	1/2"	7/8"	1-1/2"	100	300	Delavan	(2) 5.50; (1) 5.00 x 80° - B
V1117	29.0	Webster	JB20 - 30	5/16"	0.015"	1/2"	5/16"	3/4"	100	300	Delavan	(2) 5.50; (1) 6.00 x 80° - B
V1118	31.0	Webster	JB20 - 30	5/16"	0.015"	3/8"	15/16"	1-5/32"	100	300	Delavan	(3) 6.00 x 80° - B
V1119	32.5	Webster	JB20 - 30	5/16"	0.015"	3/8"	1"	1-3/8"	100	300	Delavan	(2) 6.50; (1) 6.00 x 80° - B
V1120	34.5	Webster	JB20 - 30	3/8"	0.015"	1/2"	1"	1-1/2"	100	300	Delavan	(2) 6.50; (1) 7.00 x 80° - B
V1121	36.5	Webster	JB20 - 50	3/8"	0.015"	1/2"	1"	1-1/4"	100	300	Delavan	(3) 7.00 x 80° - B
V1122	38.0	Webster	JB20 - 50	5/16"	0.015"	1-1/8"	1"	1-3/8"	100	300	Delavan	(3) 7.50 x 80° - B
V1123	40.0	Webster	JB20 - 50	5/16"	0.015"	1-1/8"	1"	1-1/2"	100	285	Delavan	(3) 8.00 x 90° - B

Table VIIIb: Webster Gas Burner Specifications

Boiler Model	Burner Input (MBH)	Burner Mfr.	Burner Model	Burner Settings			Air Inlet Settings		Manifold Pressure
				Nozzle to Diffuser	Drawer Assembly	Inner Fire Cylinder	Low Fire	High Fire	
V1104	837	Webster	JB1G - 03	1/16"	1/8"	1/4"	N/A	5/8"	1.8
V1105	1068	Webster	JB1G - 03	3/8"	1/8"	1/4"	N/A	7/8"	2.4
V1106	1328	Webster	JB1G - 03	1/4"	1/8"	1/4"	5/8"	7/8"	3.0
V1107	1588	Webster	JB1G - 05	1/4"	1/8"	1/2"	3/8"	7/8"	3.6
V1108	1876	Webster	JB1G - 05	1/4"	1/8"	3/4"	5/8"	1-1/4"	4.5
V1109	2136	Webster	JB1G - 07	1/4"	1/8"	1/4"	3/4"	1"	2.6
V1110	2396	Webster	JB1G - 07	1/4"	1/8"	1/4"	3/4"	1-1/16"	3.1
V1111	2656	Webster	JB2G - 10	3/8"	0.015"	5/16"	7/8"	1-1/8"	2.4
V1112	2887	Webster	JB2G - 10	3/8"	0.015"	5/16"	3/4"	1-1/4"	2.6
V1113	3103	Webster	JB2G - 10	3/8"	0.015"	5/16"	3/4"	1-1/4"	2.9
V1114	3392	Webster	JB2G - 10	3/8"	0.015"	5/16"	3/4"	1-1/4"	3.2
V1115	3680	Webster	JB2G - 10	3/8"	0.015"	5/16"	1-1/8"	1-3/4"	3.7
V1116	3897	Webster	JB2G - 15	5/16"	0.015"	1/2"	7/8"	1-1/2"	4.0
V1117	4186	Webster	JB2G - 30	5/16"	0.015"	1/2"	3/4"	15/16"	4.3
V1118	4474	Webster	JB2G - 30	5/16"	0.015"	3/8"	15/16"	1-5/32"	4.7
V1119	4691	Webster	JB2G - 30	5/16"	0.015"	3/8"	1"	1-3/8"	5.4
V1120	4979	Webster	JB2G - 30	3/8"	0.015"	1/2"	1"	1-1/8"	5.8
V1121	5268	Webster	JB2G - 50	3/8"	0.015"	1/2"	1"	1-1/4"	6.2
V1122	5485	Webster	JB2G - 50	5/16"	0.015"	1-1/8"	1"	1-3/8"	7.2
V1123	5773	Webster	JB2G - 50	5/16"	0.015"	1-1/8"	1"	1-1/2"	7.5

Table VIIIc: Webster Combination Gas/Oil Burner Specifications

Boiler Model	Burner Input		Burner Mfr.	Burner Model	Burner Settings			Air Inlet Settings		Manifold Pressure	Pump Pressure (PSI)		Nozzle Make	Nozzle Data GPH x Angle - Type
	Oil (GPH)	Gas (MBH)			Nozzle to Diffuser	Drawer Assembly	Inner Fire Cylinder	Low Fire	High Fire		Low Fire	High Fire		
V1104	5.8	837	Webster	JB1C - 03	1/16"	3/32"	1/4"	N/A	1/2"	1.8	N/A	280	Delavan	(2) 1.75 x 80° - B
V1105	7.4	1068	Webster	JB1C - 03	3/8"	3/32"	1/4"	N/A	5/8"	2.4	N/A	300	Delavan	(2) 2.25 x 80° - B
V1106	9.2	1328	Webster	JB1C - 03	1/4"	3/32"	1/4"	5/8"	7/8"	3.0	100	300	Delavan	(2) 2.70 x 80° - B
V1107	11.0	1588	Webster	JB1C - 05	1/4"	3/32"	1/2"	3/8"	7/8"	3.6	100	300	Delavan	(2) 3.20 x 80° - B
V1108	13.0	1876	Webster	JB1C - 05	1/4"	3/32"	3/4"	5/8"	1"	4.5	100	300	Delavan	(1) 3.50; (1) 4.00 x 80° - B
V1109	14.8	2136	Webster	JB1C - 07	1/4"	3/32"	1/4"	11/16"	1"	2.6	100	271	Delavan	(2) 4.50 x 80° - B
V1110	16.6	2396	Webster	JB1C - 07	1/4"	3/32"	1/4"	3/4"	1-1/16"	3.1	100	276	Delavan	(2) 5.00 x 80° - B
V1111	18.4	2656	Webster	JB2C - 10	3/8"	0.015"	5/16"	7/8"	1-1/8"	2.4	100	286	Delavan	(2) 5.50 x 80° - B
V1112	20.0	2887	Webster	JB2C - 10	3/8"	0.015"	5/16"	3/4"	1-1/4"	2.6	100	292	Delavan	(2) 6.00 x 80° - B
V1113	21.5	3103	Webster	JB2C - 10	3/8"	0.015"	5/16"	3/4"	1-1/4"	2.9	100	287	Delavan	(2) 6.50 x 80° - B
V1114	23.5	3392	Webster	JB2C - 10	3/8"	0.015"	5/16"	3/4"	1-1/4"	3.2	100	294	Delavan	(2) 7.00 x 80° - B
V1115	25.5	3680	Webster	JB2C - 10	3/8"	0.015"	5/16"	1-1/8"	1-3/4"	3.7	100	300	Delavan	(2) 7.50 x 80° - B
V1116	27.0	3897	Webster	JB2C - 15	5/16"	0.015"	1/2"	7/8"	1-1/2"	4.0	100	300	Delavan	(2) 5.50; (1) 5.00 x 80° - B
V1117	29.0	4186	Webster	JB2C - 30	5/16"	0.015"	1/2"	5/16"	3/4"	4.3	100	300	Delavan	(2) 5.50; (1) 6.00 x 80° - B
V1118	31.0	4474	Webster	JB2C - 30	5/16"	0.015"	3/8"	15/16"	1-5/32"	4.7	100	300	Delavan	(3) 6.00 x 80° - B
V1119	32.5	4691	Webster	JB2C - 30	5/16"	0.015"	3/8"	1"	1-3/8"	5.4	100	300	Delavan	(2) 6.50; (1) 6.00 x 80° - B
V1120	34.5	4979	Webster	JB2C - 30	3/8"	0.015"	1/2"	1"	1-1/2"	5.8	100	300	Delavan	(2) 6.50; (1) 7.00 x 80° - B
V1121	36.5	5268	Webster	JB2C - 50	3/8"	0.015"	1/2"	1"	1-1/4"	6.2	100	300	Delavan	(3) 7.00 x 80° - B
V1122	38.0	5485	Webster	JB2C - 50	5/16"	0.015"	1-1/8"	1"	1-3/8"	7.2	100	300	Delavan	(3) 7.50 x 80° - B
V1123	40.0	5773	Webster	JB2C - 50	5/16"	0.015"	1-1/8"	1"	1-1/2"	7.5	100	285	Delavan	(3) 8.00 x 90° - B

Table IX: Carlin Burner Specifications

Boiler Model	Burner Input (GPH)	Burner Mfr.	Burner Model	Air Tube Comb.	Burner Settings		Pump Pressure (PSI)		Nozzle Make	Nozzle Data GPH x Angle - Type
					Head	Air Shutter	Low Fire	High Fire		
V1105	7.4	Carlin	702CRD	97979	9/16"	1/2"	100	300	Delavan	4.50 x 60° - B
V1106	9.2	Carlin	702CRD	97979	9/16"	1/2"	100	300	Delavan	5.50 x 60° - B
V1107	11.0	Carlin	801CRD	97980	1/8"	1/2"	150	150	Hago	(1) 5.50; (1) 4.50 x 45° - H
V1108	13.0	Carlin	801CRD	97980	1/2"	1/2"	150	150	Hago	(2) 5.50 x 45° - H
V1109	14.8	Carlin	801CRD	97980	3/4"	1/2"	150	150	Hago	(2) 6.00 x 45° - H
V1110	16.6	Carlin	1050FFD	97981	1/4"	1/8"	100	100	Hago	(1) 9.00; (2) 3.75 x 45° - SS
V1111	18.4	Carlin	1050FFD	97981	7/16"	11/16"	100	100	Hago	(1) 9.00; (2) 4.50 x 45° - SS
V1112	20.0	Carlin	1050FFD	97981	3/8"	9/16"	100	100	Hago	(1) 9.00; (2) 5.50 x 45° - SS
V1113	21.5	Carlin	1050FFD	97981	9/16"	1/2"	100	100	Hago	(1) 9.00; (1) 6.50; (1) 6.00 x 45° - SS
V1114	23.5	Carlin	1150FFD	97986	0	1/4"	100	100	Hago	(1) 12.00; (1) 6.00; (1) 5.50 x 45° - SS
V1115	25.5	Carlin	1150FFD	97986	1/8"	1/2"	100	100	Hago	(1) 12.00; (1) 7.00; (1) 6.50 x 45° - SS
V1116	27.0	Carlin	1150FFD	97986	3/8"	1/2"	100	100	Hago	(1) 12.00; (2) 7.50 x 45° - SS
V1117	29.0	Carlin	1150FFD	97986	5/8"	1/2"	100	100	Hago	(1) 12.00; (2) 8.50 x 45° - SS

SECTION VII - REPAIR PARTS

All V11 Series repair parts may be obtained through your local Burnham Wholesale Distributor. Should you require assistance in locating a Burnham Distributor in your area, or have questions regarding the availability of Burnham products or repair parts, please contact Burnham Customer Service at (717) 481-8400 or Fax (717) 481-8408.

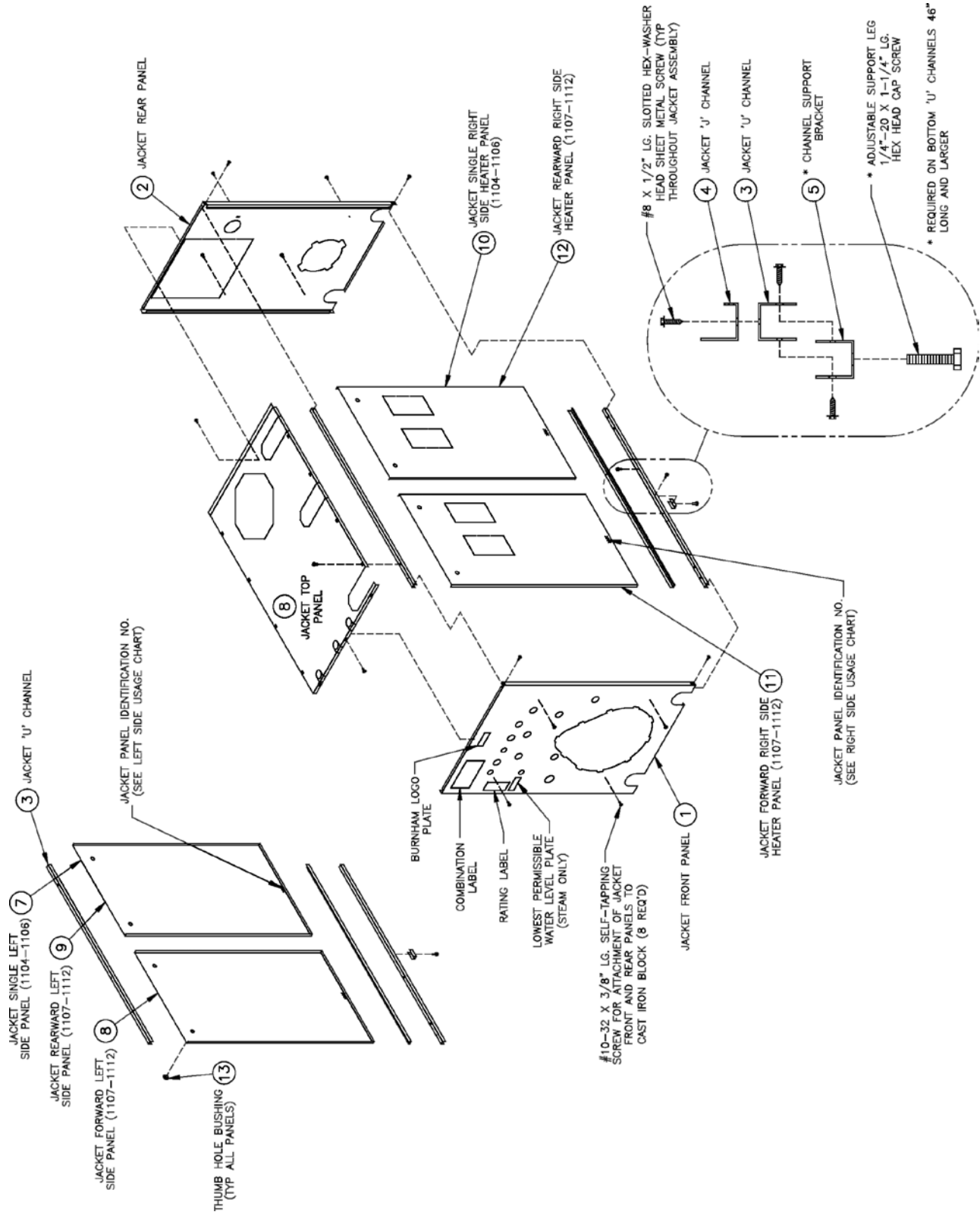

Figure 45: V11 Series Jacket Assembly (Boiler Models V1104 Thru V1112)

JACKET REPAIR PARTS (Models V1104 Thru 1112)

ITEM NO.	DESCRIPTION	B1OILER SECTIONS / QUANTITY									PART NO.
		V1104	V1105	V1106	V1107	V1108	V1109	V1110	V1111	V1112	
1	Jacket Front Panel Assembly	1	1	1	1	1	1	1	1	1	60426001
2	Jacket Rear Panel Assembly	1	1	1	1	1	1	1	1	1	60426002
3	Jacket 'U' Channels:										
	3A 'U' Channel No. U26	4									6042665
	3B 'U' Channel No. U32		4								6042666
	3C 'U' Channel No. U38			4							6042668
	3D 'U' Channel No. U44				4						6042670
	3E 'U' Channel No. U50					4					6042672
	3F 'U' Channel No. U56						4				6042674
	3G 'U' Channel No. U63							4			6042676
	3H 'U' Channel No. U69								4		6042678
	3 I 'U' Channel No. U75									4	6042680
4	Jacket 'J' Channels:										
	4A 'J' Channel No. J26	2									6042648
	4B 'J' Channel No. J32		2								6042649
	4C 'J' Channel No. J38			2							6042651
	4D 'J' Channel No. J44				2						6042653
	4E 'J' Channel No. J50					2					6042655
	4F 'J' Channel No. J56						2				6042657
	4G 'J' Channel No. J63							2			6042659
	4H 'J' Channel No. J69								2		6042661
	4 I 'J' Channel No. J75									2	6042663
5	Jacket Channel Support Bracket (Required on Bottom 'U' Channels 46" Lg. and Larger)					1	1	1	1	1	60426004
6	Jacket Top Panel Assemblies:										
	6A Jacket Top Panel Assembly, V1104	1									60426040
	6B Jacket Top Panel Assembly, V1105		1								60426050
	6C Jacket Top Panel Assembly, V1106			1							60426060
	6D Jacket Top Panel Assembly, V1107				1						60426070
	6E Jacket Top Panel Assembly, V1108					1					60426080
	6F Jacket Top Panel Assembly, V1109						1				60426090
	6G Jacket Top Panel Assembly, V1110							1			60426100
	6H Jacket Top Panel Assembly, V1111								1		60426110
	6 I Jacket Top Panel Assembly, V1112									1	60426120
7	Jacket Single Left Side Panel Assemblies:										
	7A Single L.S. Pnl. Assy., No. SLS24	1									60426043
	7B Single L.S. Pnl. Assy., No. SLS30		1								60426053
	7C Single L.S. Pnl. Assy., No. SLS36			1							60426063
8	Jacket Forward Left Side Panel Assemblies:										
	8A Forward L.S. Pnl. Assy., No. FLS27				1	1	1	1			6042636
	8A Forward L.S. Pnl. Assy., No. FLS39								1	1	6042637
9	Jacket Rearward Left Side Panel Assemblies:										
	9A Rearward L.S. Pnl. Assy., No. RLS15				1						6042641
	9B Rearward L.S. Pnl. Assy., No. RLS21					1					6042642
	9C Rearward L.S. Pnl. Assy., No. RLS27						1		1		6042643
	9D Rearward L.S. Pnl. Assy., No. RLS33							1		1	6042644
10	Jacket Single Right Side Heater Panel Assemblies:										
	10A Single R.S. Htr. Pnl. Assy., No. SRH24	1									60426042
	10B Single R.S. Htr. Pnl. Assy., No. SRH30		1								60426052
	10C Single R.S. Htr. Pnl. Assy., No. SRH36			1							60426062
11	Jacket Forward Right Side Heater Panel Assemblies:										
	11A Forward R.S. Htr. Pnl. Assy., No. FRH27				1	1	1	1			6042624
	11B Forward R.S. Htr. Pnl. Assy. No. FRH39								1	1	6042625
12	Jacket Rearward Right Side Heater Panel Assemblies:										
	12A Rearward R.S. Htr., Pnl. Assy., No. RRH15				1						6042629
	12B Rearward R.S. Htr., Pnl. Assy., No. RRH21					1					6042630
	12C Rearward R.S. Htr., Pnl. Assy., No. RRH27						1		1		6042631
	12D Rearward R.S. Htr., Pnl. Assy., No. RRH33							1		1	6042632
13	Thumb Hole Bushing, Heyco SB-1093-15, #2166 Black	4	4	4	6	8	8	8	8	8	8136257

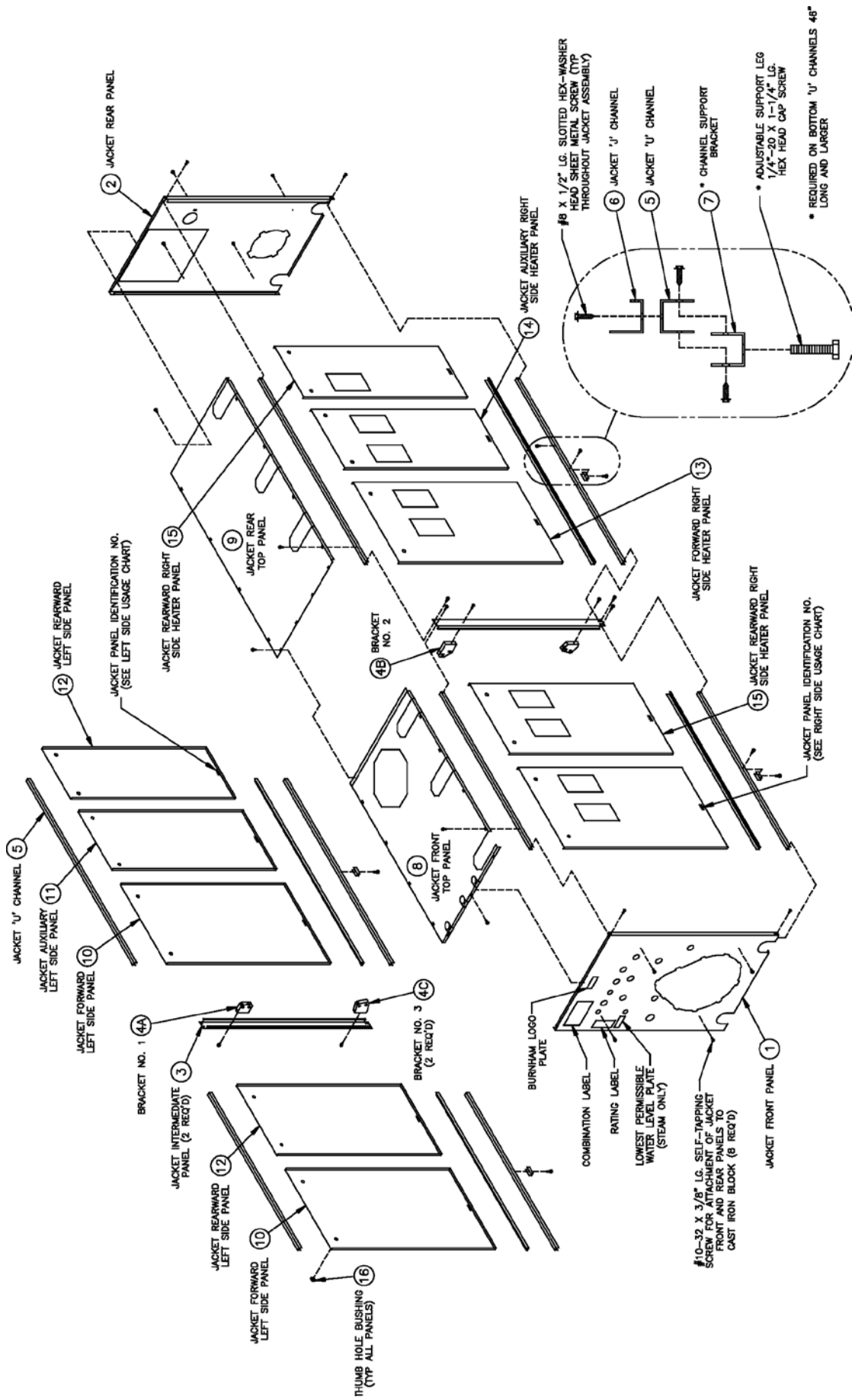
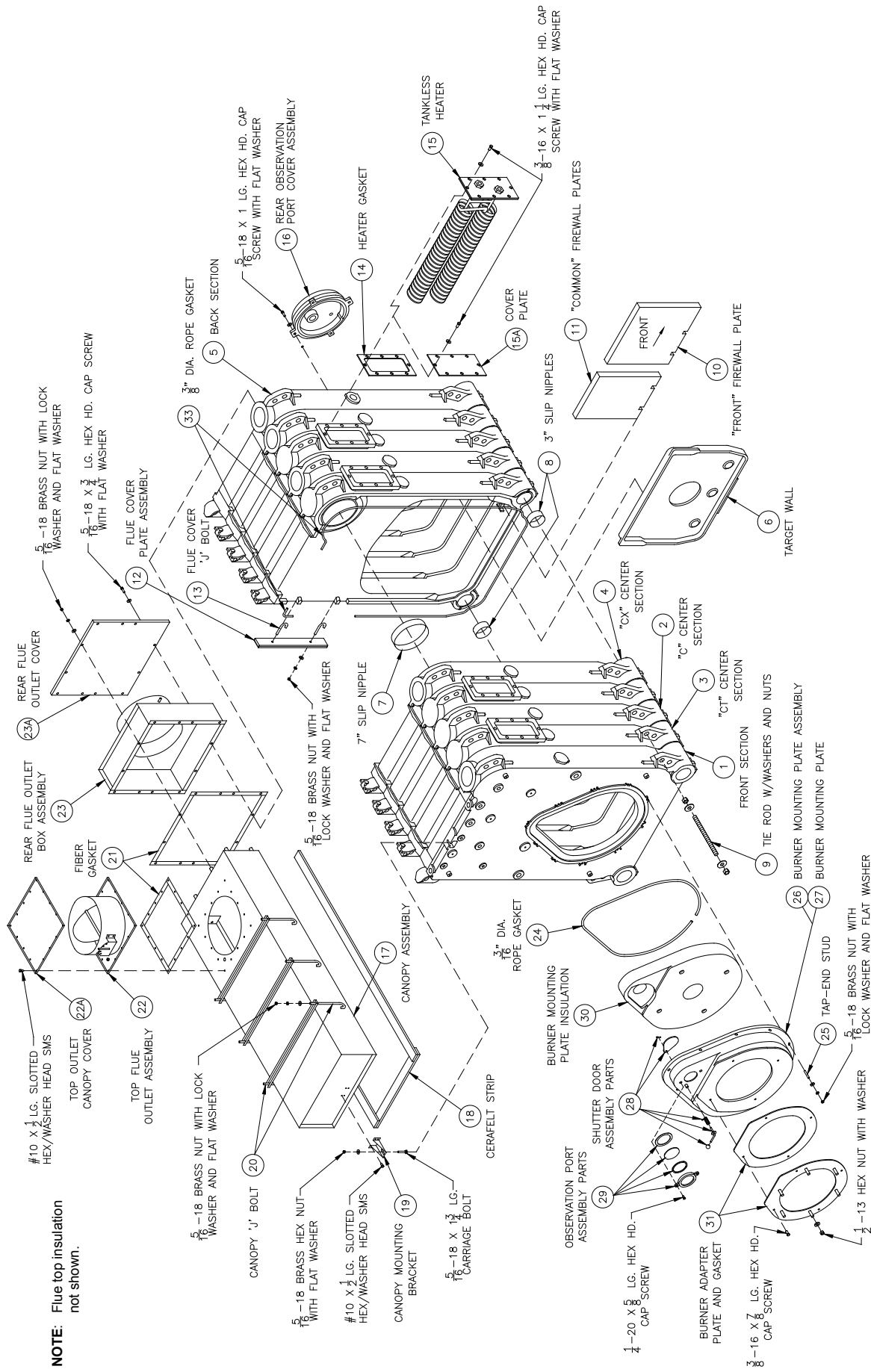

Figure 46: V11 Series Jacket Assembly (Boiler Models V1113 Thru V1123)

JACKET REPAIR PARTS (Models V1113 Thru 1123)

ITEM NO.	DESCRIPTION	B1OILER SECTIONS / QUANTITY											PART NO.
		V1113	V1114	V1115	V1116	V1117	V1118	V1119	V1120	V1121	V1122	V1123	
1	Jacket Front Panel Assembly	1	1	1	1	1	1	1	1	1	1	1	60426001
2	Jacket Rear Panel Assembly	1	1	1	1	1	1	1	1	1	1	1	60426002
3	Jacket Intermediate Panel Assembly	2	2	2	2	2	2	2	2	2	2	2	60426003
4	Jacket Intermediate Panel Mounting Brackets:												
	4A Bracket No. 1	1	1	1	1	1	1	1	1	1	1	1	6042601
	4B Bracket No. 2	1	1	1	1	1	1	1	1	1	1	1	6042602
	4C Bracket No. 3	2	2	2	2	2	2	2	2	2	2	2	6042603
5	Jacket 'U' Channels:												
	5A 'U' Channel No. U34	4											6042667
	5B 'U' Channel No. U40		4										6042669
	5C 'U' Channel No. U46	4	4	8	4								6042671
	5D 'U' Channel No. U52				4	8	4	4					6042673
	5E 'U' Channel No. U58						4						6042675
	5F 'U' Channel No. U65							4	4	8	4	4	6042677
	5G 'U' Channel No. U71										4		6042679
	5H 'U' Channel No. U77											4	6042681
6	Jacket 'J' Channels"												
	6A 'J' Channel No. J34	2											6042650
	6B 'J' Channel No. J40		2										6042652
	6C 'J' Channel No. J46	2	2	4	2								6042654
	6D 'J' Channel No. J52				2	4	2	2					6042656
	6E 'J' Channel No. J58						2		2				6042658
	6F 'J' Channel No. J65							2	2	4	2	2	6042660
	6G 'J' channel No. J71										2		6042662
	6H 'J' Channel No. J77											2	6042664
7	Jacket Channel Support Bracket (Required on Bottom 'U' Channels 46" Lg. and Larger)	2	2	4	4	4	4	4	4	4	4	4	60426004
8	Jacket Front Top Panel Assemblies:												
	8A Jacket Front Top Panel Assy., V1113	1											60426130
	8B Jacket Front Top Panel Assy., V1114/15		1	1									60426140
	8C Jacket Front Top Panel Assy., V1116/17				1	1							60426160
	8D Jacket Front Top Panel Assy., V1118						1						60426180
	8E Jacket Front Top Panel Assy., V1119/21							1	1	1			60426190
	8F Jacket Front Top Panel Assy., V1122/23										1	1	60426200
9	Jacket Rear Top Panel Assemblies:												
	9A Jacket Rear Top Panel Assy., V1113	1											60426134
	9B Jacket Rear Top Panel Assy., V1114		1										60426144
	9C Jacket Rear Top Panel Assy., V1115			1									60426154
	9D Jacket Rear Top Panel Assy., V1116				1								60426164
	9E Jacket Rear Top Panel Assy., V1117					1							60426174
	9F Jacket Rear Top Panel Assy., V1118						1						60426184
	9G Jacket Rear Top Panel Assy., V1119							1					60426194
	9H Jacket Rear Top Panel Assy., V1120								1				60426204
	9I Jacket Rear Top Panel Assy., V1121									1			60426214
	9J Jacket Rear Top Panel Assy., V1122										1		60426224
	9K Jacket Rear Top Panel Assy., V1123											1	60426234
10	Jacket Forward Left Side Panel Assemblies:												
	10A Forward L.S. Panel Assy., No.FLS17	1	1	1									6042639
	10B Forward L.S. Panel Assy., No.FLS27	1	1	1									6042636
	10C Forward L.S. Panel Assy., No.FLS29				1	1	1	1	1	1	1	1	6042640
	10D Forward L.S. Panel Assy., No.FLS33				1	1	1	1	1	1	1	1	6042638
11	Jacket Auxiliary L.S. Panel Assy., No. ALS24												
12	Jacket Rearward Left Side Panel Assemblies:												
	12A Rearward L.S. Panel Assy., No. RLS15	1			1						1		6042641
	12B Rearward L.S. Panel Assy., No. RLS17	1	1	1	1	1	1						6042645
	12C Rearward L.S. Panel Assy., No. RLS21		1			1		1				1	6042642
	12D Rearward L.S. Panel Assy., No. RLS27			1			1		1				6042643
	12E Rearward L.S. Panel Assy., No. RLS29							1	1	1	1	1	6042646
	12F Rearward L.S. Panel Assy., No. RLS33									1			6042644
13	Jacket Forward Right Side Heater Panel Assemblies:												
	13A Forward R.S. Htr. Pnl. Assy., No. FRH17	1	1	1									6042627
	13B Forward R.S. Htr. Pnl. Assy., No. FRH27	1	1	1									6042624
	13C Forward R.S. Htr. Pnl. Assy., No. FRH29				1	1	1	1	1	1	1	1	6042628
	13D Forward R.S. Htr. Pnl. Assy., No. FRH33				1	1	1	1	1	1	1	1	6042626
14	Jacket Auxiliary Right Side Heater Panel Assy., No. ARH24												
15	Jacket Rearward Right Side Heater Panel Assemblies:												
	15A Rearward R.S. Htr. Pnl. Assy., No. RRH15	1			1						1		6042629
	15B Rearward R.S. Htr. Pnl. Assy., No. RRH17	1	1	1	1	1	1						6042633
	15C Rearward R.S. Htr. Pnl. Assy., No. RRH21		1			1		1				1	6042630
	15D Rearward R.S. Htr. Pnl. Assy., No. RRH27			1			1		1				6042631
	15E Rearward R.S. Htr. Pnl. Assy., No. RRH29							1	1	1	1	1	6042634
	15F Rearward R.S. Htr. Pnl. Assy., No. RRH33									1			6042632
16	Thumb Hole Bushing, Heyco #2166, Black	10	12	12	12	14	14	16	16	16	16	20	8136257



NOTE: Flue top insulation not shown.

Figure 47: Bare Boiler Assembly

REPAIR PARTS FOR BARE BOILER ASSEMBLY

ITEM NO.	DESCRIPTION	BOILER SECTIONS / QUANTITY																				PART NO.
		04	05	06	07	08	09	10	11	12	13	14	15	16	17	18	19	20	21	22	23	
1	Front Section	1	1	1	1	1	1	1	1	1	1	1	1	1	1	1	1	1	1	1	1	7172614
2	"C" Center Section - Steam Boiler	2	3	4	5	6	7	7	8	9	10	10	11	12	13	13	14	15	16	16	17	7172617
	Water Boiler	2	3	4	5	6	7	8	9	10	11	12	13	13	14	15	16	17	18	19	20	7172617
	Optional - "CT" Center Section w/Tankless Heater Opening -																					
3	Max. No. Heater - ("CT") Replaces "C" Center Section	1	2	2	3	3	4	4	4	5	5	5	6	6	6	7	7	8	8	9	9	7172619
4	"CX" Center Section with 4" Supply Tapping - Steam Boiler							1	1	1	1	2	2	2	2	3	3	3	3	4	4	7172618
	Water Boiler														1	1	1	1	1	1	1	7172618
5	Back Section	1	1	1	1	1	1	1	1	1	1	1	1	1	1	1	1	1	1	1	1	7172616
6	Target Wall (V1104 thru V1106 only)	1	1	1																		6202601
	Silastic, 500°F, 10 oz. Tube	2	2	3	4	5	5	6	7	8	8	9	10	11	11	12	13	14	14	15	16	9056060
7	7" Cast Iron Slip Nipple	3	4	5	6	7	8	9	10	11	12	13	14	15	16	17	18	19	20	21	22	7066004
8	3" Cast Iron Slip Nipple	6	8	10	12	14	16	18	20	22	24	26	28	30	32	34	36	38	40	42	44	7066002
	Nipple Gauge, 3" & 7"	1	1	1	1	1	1	1	1	1	1	1	1	1	1	1	1	1	1	1	1	806600023
	Nipple Lubricant, Loctite® #592, 50 ml	2	2	3	3					1	1	2	2	3	3							8056254
	250 ml					1	1	1	1	1	1	1	1	1	1	2	2	2	2	2	2	8056255
9	3/4" - 10 x 11" Lg. Tie Rod	12	16	20	24	28	32	36	40	44	48	52	56	60	64	68	72	76	80	84	88	80861092
10	"Front" Firewall Plate	1	1	1	1	1	1	1	1	1	1	1	1	1	1	1	1	1	1	1	1	8202603
11	"Common" Firewall Plate			1	1	2	2	3	3	4	4	5	5	5	5	5	5	5	5	5	5	8202604
12	Formed Steel Flue Cover Plate	3	4	5	6	7	8	9	10	11	12	13	14	15	16	17	18	19	20	21	22	6112601
13	Flue Cover "J" Bolt, 5/16" -18 x 2-3/4" Lg.	6	8	10	12	14	16	18	20	22	24	26	28	30	32	34	36	38	40	42	44	80861680
14	Tankless Heater/Cover Plate Gasket	(One Required for each "CT" Section)																				8032601
15A	V11-2 Tankless Heater Assembly	(One Required for each "CT" Section)																				6032601
	- OR -																					
15B	Blank Heater Cover Plate Only	(One Required for each "CT" Section)																				6032602
16	Rear Observation Port Cover (Incls. gasket & mounting hdwe)	1	1	1	1	1	1	1	1	1	1	1	1	1	1	1	1	1	1	1	1	609600011
17	Canopy Assemblies																					
	<u>One Piece Canopy</u>																					
17A	Canopy Assembly, V1104	1																				6112604
17B	Canopy Assembly, V1105		1																			6112605
17C	Canopy Assembly, V1106			1																		6112606
17D	Canopy Assembly, V1107				1																	6112607
17E	Canopy Assembly, V1108					1																6112608
17F	Canopy Assembly, V1109						1															6112609
17G	Canopy Assembly, V1110							1														6112610
17H	Canopy Assembly, V1111								1													6112611
17I	Canopy Assembly, V1112									1												6112612
	<u>Two Piece Canopy</u>																					
17J	Canopy Front Portion Assembly, V1113										1											6112624
17K	Canopy Front Portion Assembly, V1114 / V1117											1	1	1	1							6112625
17L	Canopy Front Portion Assembly, V1118 / V1121															1	1	1	1			6112626
17M	Canopy Front Portion Assembly, V1122 / V1123																			1	1	61126260
17N	Canopy Front Portion Assembly, V1113										1											6112613
17O	Canopy Front Portion Assembly, V1114											1										6112614
17P	Canopy Front Portion Assembly, V1115												1									6112615
17Q	Canopy Front Portion Assembly, V1116													1								6112616
17R	Canopy Front Portion Assembly, V1117														1							6112617
17S	Canopy Front Portion Assembly, V1118															1						6112618
17T	Canopy Front Portion Assembly, V1119																1					6112619
17U	Canopy Front Portion Assembly, V1120																	1				6112620
17V	Canopy Front Portion Assembly, V1121																		1			6112621
17W	Canopy Front Portion Assembly, V1122																			1		6112622
17X	Canopy Front Portion Assembly, V1123																				1	6112623
18	Cerafelt Gasket (1/2" x 2" Wide x L.F.)	7	8	9	10	11	12	13	14	15	16	17	18	19	20	21	22	23	24	25	26	9206003
19	Canopy Mounting Bracket	1	1	1	1	1	1	1	1	1	1	1	1	1	1	1	1	1	1	1	1	71126002

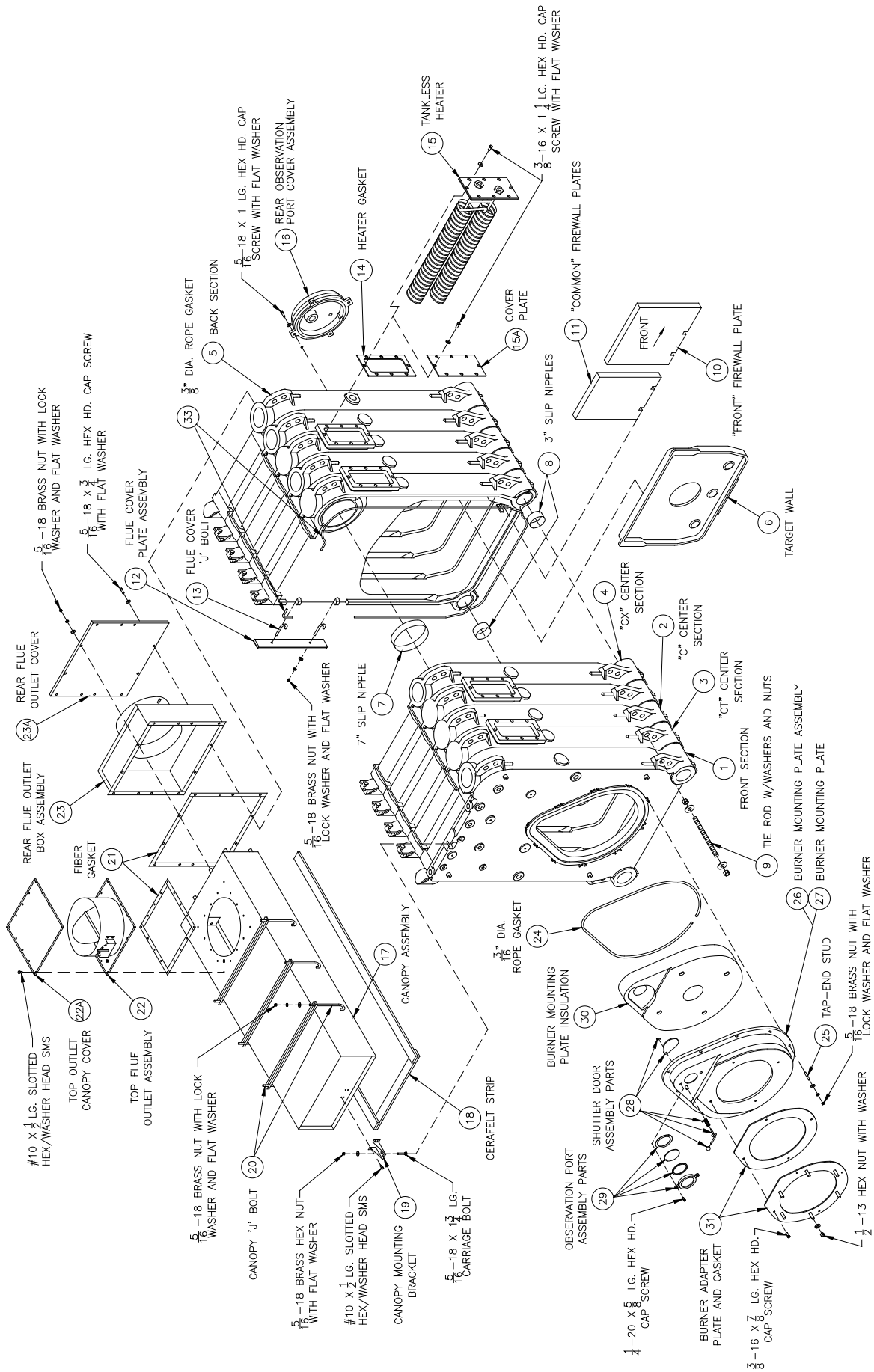

Figure 47: Bare Boiler Assembly

REPAIR PARTS FOR BARE BOILER ASSEMBLY (continued)

ITEM NO.	DESCRIPTION	BOILER SECTIONS / QUANTITY																							PART NO.
		04	05	06	07	08	09	10	11	12	13	14	15	16	17	18	19	20	21	22	23				
20	Canopy 'J' Bolt, 5/16 - 18 x 7-3/4 Lg.	2	2	2	2	4	4	6	6	8	8	10	10	12	12	14	14	16	16	18	18	80861679			
21	Adhesive Fiber Gasket, 1/8" x 1" Wide x L.F.	12	12	12	13	13	13	13	13	13	17	17	17	17	17	18	18	18	18	19	19	9206032			
22	Top Flue Outlet Assembly, 8"	1	1	1																		6112627			
	10"				1	1	1															6112628			
	12"							1	1	1	1											6112629			
	14"										1	1	1	1								6112630			
	16"														1	1	1	1				6112631			
	18"																		1	1		6112637			
22A	Top Outlet Canopy Cover, 8" Opening	1	1	1																		7112638			
	10"				1	1	1															7112639			
	12"							1	1	1	1											7112640			
	14"										1	1	1	1								7112641			
	16"														1	1	1	1				7112642			
	18"																		1	1		71126420			
	- OR -																								
23	Rear Flue Outlet Assembly, 8" Collar	1	1	1																		6112632			
	10"				1	1	1															6112633			
	12"							1	1	1	1											6112634			
	14"										1	1	1	1								6112635			
	16"														1	1	1	1				6112636			
	18"																		1	1		6112638			
23A	Rear Flue Outlet Cover	1	1	1	1	1	1	1	1	1	1	1	1	1	1	1	1	1	1	1	1	7112632			
24	3/16" Dia. Rope Gasket x L.F.	7	7	7	7	7	7	7	7	7	7	7	7	7	7	7	7	7	7	7	7	72026021			
25	5/16" - 18 x 2" Lg. Tap-end Stud	10	10	10	10	10	10	10	10	10	10	10	10	10	10	10	10	10	10	10	10	80861606			
26	Standard Burner Mounting Plate Assembly (Above Assembly Includes Items 27A, 28 and 29)	1	1	1	1	1	1	1	1	1	1	1	1	1	1	1	1	1	1	1	1	6022601			
27	Standard C.I. Burner Mounting Plate (Machined)	1	1	1	1	1	1	1	1	1	1	1	1	1	1	1	1	1	1	1	1	7172601			
28	Shutter Door Assembly Parts:																								
28A	Handle Knob	1	1	1	1	1	1	1	1	1	1	1	1	1	1	1	1	1	1	1	1	8026036			
28B	Shutter Handle	1	1	1	1	1	1	1	1	1	1	1	1	1	1	1	1	1	1	1	1	8026033			
28C	Shutter Spring	1	1	1	1	1	1	1	1	1	1	1	1	1	1	1	1	1	1	1	1	8026034			
28D	Observation Port Shutter (Machined & painted)	1	1	1	1	1	1	1	1	1	1	1	1	1	1	1	1	1	1	1	1	70260051			
28E	Spring Pin	1	1	1	1	1	1	1	1	1	1	1	1	1	1	1	1	1	1	1	1	8026035			
29	Observation Port Assembly Parts:																								
29A	Observation Port Cover (Machined & Painted)	1	1	1	1	1	1	1	1	1	1	1	1	1	1	1	1	1	1	1	1	70260041			
29B	Observation Port Outer Gasket	1	1	1	1	1	1	1	1	1	1	1	1	1	1	1	1	1	1	1	1	8206001			
29C	Observation Port Glass	1	1	1	1	1	1	1	1	1	1	1	1	1	1	1	1	1	1	1	1	8026032			
29D	Observation Port Inner Gasket	1	1	1	1	1	1	1	1	1	1	1	1	1	1	1	1	1	1	1	1	8206002			
30	Standard Burner Mounting Plate Insulation	1	1	1	1	1	1	1	1	1	1	1	1	1	1	1	1	1	1	1	1	8202601			
31	Burner Adapter Plate Assembly w/Gasket and Hardware:																								
31A	Beckett ("CF") BAP No. "00", 6-3/4" Dia. Hole	1	1	1	1	1	1				1	1										602263001			
31B	Beckett ("CF") BAP No. "01", 8-1/4" Dia. Hole							1	1			1	1									600263011			
31C	Beckett ("CF") BAP No. "02", 10-1/4" Dia. Hole														1							602263021			
	- OR -																								
31D	Power Flame ("C") BAP No. "40", 7-1/2" Dia. Hole	1	1																			602263401			
31E	Power Flame ("C") BAP No. "41", 9" Dia. Hole			1	1	1	1															602263411			
31F	Power Flame ("C") BAP No. "42", 10-3/8" Dia. Hole									1	1	1	1	1	1	1	1	1	1	1	1	602263421			
	- OR -																								
31G	Power Flame ("JR") BAP No. "45", 6-3/8" Dia. Hole	1	1																			602263451			
31H	Power Flame ("JR") BAP No. "46", 8-3/8" Dia. Hole			1	1	1																602263461			
32	Burner Adapter Plate Gasket Only	1	1	1	1	1	1	1	1	1	1	1	1	1	1	1	1	1	1	1	1	8022601			
33	3/8" Dia. Rope Gasket	3	4	5	6	7	8	9	10	11	12	13	14	15	16	17	18	19	20	21	22	7202648			

STEAM TRIM / WATER TRIM

STEAM TRIM	V1104-6	V1107-9	V1110-12	V1113-17	V1118-20	V1121-23	PART NO.
Pressuretrol, Honeywell L404A1354	1	1	1	1	1	1	80160301
Steam Gauge, 4" Dia., 30" -0-30 PSI, 1/4" NPT	1	1	1	1	1	1	8056022
Gauge Glass Set, Conbraco #20-104-10 (8-5/8")	1	1	1	1	1	1	8056150
Safety Valve Piping:							
Nipple, 3" NPT x Close, Black	1	1	1	1	1		806600223
Nipple, 3" NPT x 4", Black						1	806600110
Tee, 3" NPT, Black	1	1	1	1	1	1	806601064
Hex Bushing, 3" NPT x 1 1/4" FPT, Black	1						806600560
Hex Bushing, 3" NPT x 1 1/2" FPT, Black		1					806600542
Hex Bushing, 3" NPT x 2" FPT, Black			1				806600557
Hex Bushing, 3" NPT x 2 1/2" FPT, Black				1			806600543
Safety Valve, Conbraco #13-213-08, 1 1/4" MPT x 1 1/2" FPT	1						81660505
Safety Valve, Conbraco #13-214-08, 1 1/2" MPT x 2" FPT		1					81660503
Safety Valve, Conbraco #12-205-08, 2" MPT x 2" FPT			1				81660507
Safety Valve, Conbraco #12-206-08, 2 1/2" MPT x 2 1/2" FPT				1			81660508
Safety Valve, Conbraco #12-208-08, 3" MPT x 3" FPT					1		81660509
Safety Valve, Conbraco #14-207-08, 3" MPT x 3" FPT						1	81660521
Hex Bushing, 3/4" MPT x 1/2" FPT, Black (Mount Syphon)	1	1	1	1	1	1	806600508
Hex Bushing, 3" MPT x 3/4" FPT, Black (Mount Drain Valve)	1	1	1	1	1	1	806600509
Hex Bushing, 1/2" MPT x 1/4" FPT, Black (Mount Steam Gauge)	1	1	1	1	1	1	806600524
Drain Valve, 3/4" x 1 1/2" Lg. Conbraco #31-606-02	1	1	1	1	1	1	806603011
Syphon, 1/4" x 90°, 1-7/8" x 4" Extended Leg	1	1	1	1	1	1	806603010
Plug Extra Tappings:							
Pipe Plug, 3/4" NPT, Countersunk, Black	1	1	1	1	1	1	806603504
Pipe Plug, 1" NPT, Countersunk, Black	1	1	1	1	1	1	806603517
Pipe Plug, 3/4" NPT, Square Head, Black	2	2	2	2	2	2	806603512
Pipe Plug, 1" NPT, Square Head, Black	3	3	3	3	3	3	806603501
Pipe Plug, 3" NPT, Square Head, Black	1	1	1	1	1	1	806603514
Lowest Permissible Water Level Plate, Form No. 1204A	1	1	1	1	1	1	81460009

WATER TRIM	V1104-7	V1108-11	V1112-20	V1121-23	PART NO.
Aquastat Controller, Honeywell L4006A2015	1	1	1	1	80160400U
Immersion Well, Honeywell #123871A, 3/4" NPT	1	1	1	1	80160452
Temperature Pressure Gauge, 100 PSI, 80-320°F, 1/2" NPT	1	1	1	1	8056028
Relief Valve Piping:					
Hex Bushing, 3" NPT x 3/4" FPT, Black	1				806600509
Hex Bushing, 3" NPT x 1" FPT, Black		1			806600559
Hex Bushing, 3" NPT x 1 1/4" FPT, Black			1		806600560
Hex Bushing, 3" NPT x 1 1/2" FPT, Black				1	806600542
Nipple, 3/4" NPT x 3" Lg., Black	1				806600002
Nipple, 1" NPT x 3" Lg., Black		1			806600027
Nipple, 1 1/4" NPT x 3" Lg., Black			1		806600005
Nipple, 1 1/2" NPT x 3" Lg., Black				1	806600006
Street Elbow, 3/4" NPT x 90°, Malleable	1				806601501
Street Elbow, 1" NPT x 90°, Malleable		1			806601514
Street Elbow, 1 1/4" NPT x 90°, Malleable			1		806601516
Street Elbow, 1 1/2" NPT x 90°, Malleable				1	806601517
Relief Valve, Conbraco #10-614-10, 3/4" x 1" FPT, 50# Working Pressure	1				81660359
Relief Valve, Conbraco #10-615-10, 1" x 1 1/4" FPT, 50# Working Pressure		1			81660362
Relief Valve, Conbraco #10-616-10, 1 1/4" x 1" FPT, 50# Working Pressure			1		81660357
Relief Valve, Conbraco #10-617-10, 1 1/2" x 2" FPT, 50# Working Pressure				1	81660364
Hex Bushing, 3" NPT x 3/4" FPT, Black (Mount Drain Valve)	1	1	1	1	806600509
Drain Valve, 3/4" NPT x 1 1/2" Lg., Conbraco #31-606-02	1	1	1	1	806603011
Plug Extra Tappings:					
Pipe Plug, 1/2" NPT, Countersunk, Black	2	2	2	2	806603510
Pipe Plug, 3/4" NPT, Countersunk, Black	1	1	1	1	806603504
Pipe Plug, 1" NPT, Countersunk, Black	1	1	1	1	806603517
Pipe Plug, 3/4" NPT, Square Head, Black	2	2	2	2	806603512
Pipe Plug, 1" NPT, Square Head, Black	3	3	3	3	806603501
Pipe Plug, 3" NPT, Square Head, Black	2	2	1		806603514
Pipe Plug, 4" NPT, Square Head, Black	1	1	1	1	806603590

Limited Warranty

For Commercial Grade Boilers

Using Cast Iron, Carbon Steel,
or Stainless Steel Heat Exchangers
and Parts/Accessories

Subject to the terms and conditions set forth below, Burnham Commercial, Lancaster, Pennsylvania hereby extends the following limited warranties to the original owner of a commercial grade water or steam boiler or Burnham Commercial supplied parts and/or accessories manufactured and shipped on or after October 1, 2009:

ONE YEAR LIMITED WARRANTY ON COMMERCIAL GRADE BOILERS AND PARTS / ACCESSORIES SUPPLIED BY BURNHAM COMMERCIAL.

Burnham Commercial warrants to the original owner that its commercial grade water and steam boilers and parts/accessories comply at the time of manufacture with recognized hydronic industry standards and requirements then in effect and will be free of defects in material and workmanship under normal usage for a period of one year from the date of original installation. If any part of a commercial grade boiler or any part or accessory provided by Burnham Commercial is found to be defective in material or workmanship during this one year period, Burnham Commercial will, at its option, repair or replace the defective part (not including labor).

HEAT EXCHANGER WARRANTIES

Burnham Commercial warrants to the original owner that the heat exchanger of its commercial grade boilers will remain free from defects in material and workmanship under normal usage for the time period specified in the chart below to the original owner at the original place of installation. If a claim is made under this warranty during the "No Charge" period from the date of original installation, Burnham Commercial will, at its option, repair or replace the heat exchanger (not including labor). If a claim is made under this warranty after the expiration of the "No Charge" period from the date of original installation, Burnham Commercial will, at its option and upon payment of the pro-rated service charge set forth below, repair or replace the heat exchanger. The service charge applicable to a heat exchanger warranty claim is based upon the number of years the heat exchanger has been in service and will be determined as a percentage of the retail price of the heat exchanger model involved at the time the warranty claim is made as follows:

Years in Service	Service Charge as a % of Retail Price									
	1	2	3	4	5	6	7	8	9	10+
Cast Iron	No Charge									100
Carbon Steel	No Charge		100							
Stainless Steel	No Charge			20	40	60	80	100		

NOTE: If the heat exchanger involved is no longer available due to product obsolescence or redesign, the value used to establish the retail price will be the published price as set forth in Burnham Commercial Repair Parts Pricing where the heat exchanger last appeared or the current retail price of the then nearest equivalent heat exchanger, whichever is greater.

ADDITIONAL TERMS AND CONDITIONS

- Applicability: The limited warranties set forth above are extended only to the original owner at the original place of installation within the United States and Canada. These warranties are applicable only to boilers, parts, or accessories designated as commercial grade by Burnham Commercial and installed and used exclusively for purposes of commercial space heating or domestic hot water generation through a heat exchanger (or a combination for such purposes) and do not apply to residential grade products or industrial uses.
- Components Manufactured by Others: Upon expiration of the one year limited warranty on commercial grade boilers, all boiler components other than heat exchangers manufactured by others but furnished by Burnham Commercial (such as oil burner, circulator and controls) will be subject only to the manufacturer's warranty, if any.
- Proper Installation: The warranties extended by Burnham Commercial are conditioned upon the installation of the commercial grade boiler, parts, and accessories in strict compliance with Burnham Commercial installation instructions. Burnham Commercial specifically disclaims liability of any kind caused by or relating to improper installation.
- Proper Use and Maintenance: The warranties extended by Burnham Commercial conditioned upon the use of the commercial grade boiler, parts, and accessories for its intended purposes and its maintenance accordance with Burnham Commercial recommendations and hydronics industry standards. For proper installation, use, and maintenance, see all applicable sections of the Installation and Operating, and Service Instructions Manual furnished with the unit.
- This warranty does not cover the following:
 - Expenses for removal or reinstallation. The owner will be responsible for the cost of removing and reinstalling the alleged defective part or its replacement and all labor and material connected therewith, and transportation to and from Burnham Commercial.
 - Components that are part of the heating system but were not furnished by Burnham Commercial as part of the commercial boiler.
 - Improper burner adjustment, control settings, care or maintenance.
 - This warranty cannot be considered as a guarantee of workmanship of an installer connected with the installation of the Burnham Commercial boiler, or as imposing on Burnham Commercial liability of any nature for unsatisfactory performance as a result of faulty workmanship in the installation, which liability is expressly disclaimed.

- Boilers, parts, or accessories installed outside the 48 contiguous United States, the State of Alaska and Canada.
- Damage to the boiler and/or property due to installation or operation of the boiler that is not in accordance with the boiler installation and operating instruction manual.
- Any damage or failure of the boiler resulting from hard water, scale buildup or corrosion the heat exchanger.
- Any damage caused by improper fuels, fuel additives or contaminated combustion air that may cause fireside corrosion and/or clogging of the burner or heat exchanger.
- Any damage resulting from combustion air contaminated with particulate which cause clogging of the burner or combustion chamber including but not limited to sheetrock or plasterboard particles, dirt, and dust particulate.
- Any damage, defects or malfunctions resulting from improper operation, maintenance, misuse, abuse, accident, negligence including but not limited to operation with insufficient water flow, improper water level, improper water chemistry, or damage from freezing.
- Any damage caused by water side clogging due to dirty systems or corrosion products from the system.
 - Any damage resulting from natural disaster.
- Damage or malfunction due to the lack of required maintenance outlined in the Installation and Operating Manuals furnished with the unit.
- Exclusive Remedy: Burnham Commercial obligation for any breach of these warranties is limited to the repair or replacement of its parts (not including labor) in accordance with the terms and conditions of these warranties.
- Limitation of Damages: Under no circumstances shall Burnham Commercial be liable for incidental, indirect, special or consequential damages of any kind whatsoever under these warranties, including, but not limited to, injury or damage to persons or property and damages for loss of use, inconvenience or loss of time. Burnham Commercial liability under these warranties shall under no circumstances exceed the purchase price paid by the owner for the commercial grade boiler involved. Some states do not allow the exclusion or limitation of incidental or consequential damages, so the above limitation or exclusion may not apply to you.
- Limitation of Warranties: These warranties set forth the entire obligation of Burnham Commercial with respect to any defect in a commercial grade boiler, parts, or accessories and Burnham Commercial shall have no express obligations, responsibilities or liabilities of any kind whatsoever other than those set forth herein. These warranties are given in lieu of all other express warranties.

ALL APPLICABLE IMPLIED WARRANTIES, IF ANY, INCLUDING ANY WARRANTY OF MERCHANTABILITY OR FITNESS FOR A PARTICULAR PURPOSE ARE EXPRESSLY LIMITED IN DURATION TO A PERIOD OF ONE YEAR EXCEPT THAT IMPLIED WARRANTIES, IF ANY, APPLICABLE TO THE HEAT EXCHANGER IN A COMMERCIAL GRADE BOILER SHALL EXTEND TO THE ORIGINAL OWNER FOR THE TIME SPECIFIED IN THE HEAT EXCHANGER SECTION SHOWN ABOVE AT THE ORIGINAL PLACE OF INSTALLATION. SOME STATES DO NOT ALLOW LIMITATION ON HOW LONG AN IMPLIED WARRANTY LASTS, SO THE ABOVE LIMITATION MAY NOT APPLY TO YOU.

PROCEDURE FOR OBTAINING WARRANTY SERVICE

In order to assure prompt warranty service, the owner is requested to complete and mail the Warranty Card provided with the product or register product online at www.burnhamcommercialcastiron.com within ten days after the installation of the boiler, although failure to comply with this request will not void the owner's rights under these warranties. Upon discovery of a condition believed to be related to a defect in material or workmanship covered by these warranties, the owner should notify the installer, who will in turn notify the distributor. If this action is not possible or does not produce a prompt response, the owner should write to Burnham Commercial, P.O. Box 3939, Lancaster, PA 17604, giving full particulars in support of the claim. The owner is required to make available for inspection by Burnham Commercial or its representative the parts claimed to be defective and, if requested by Burnham Commercial to ship these parts prepaid to Burnham Commercial at the above address for inspection or repair. In addition, the owner agrees to make all reasonable efforts to settle any disagreement arising in connection with a claim before resorting to legal remedies in the courts.

THIS WARRANTY GIVES YOU SPECIFIC LEGAL RIGHTS AND YOU MAY ALSO HAVE OTHER RIGHTS WHICH VARY FROM STATE TO STATE.



Burnham Commercial, P.O. Box 3939, Lancaster, PA 17604

Revised November 1, 2009