

# INSTALLATION, OPERATING AND SERVICE INSTRUCTIONS FOR RSA BOILERS



For service or repairs to boiler, call your heating contractor. When seeking information on boiler, provide Boiler Model Number and Serial Number as shown on Rating Label.

Boiler Model Number _RSA _ _ _ _ _	Boiler Serial Number 6 _ _ _ _ _	Installation Date
Heating Contractor		Phone Number
Address		

---

## IMPORTANT INFORMATION - READ CAREFULLY

---

All boilers must be installed in accordance with National, State and Local Plumbing, Heating and Electrical Codes and the regulations of the serving utilities. These Codes and Regulations may differ from this instruction manual. Authorities having jurisdiction should be consulted before installations are made.

In all cases, reference should be made to the following Standards:

All wiring on boilers installed in the USA shall be made in accordance with the National Electrical Code and/or Local Regulations.

All wiring on boilers installed in Canada shall be made in accordance with the Canadian Electrical Code and/or Local Regulations.

### USA BOILERS

- A. Current Edition of American National Standard ANSI/NFPA 31, "Installation of Oil Burning Equipment", for recommended installation practices.
- B. Current Edition of American National Standard ANSI/NFPA 211, "Chimneys, Fireplaces, Vents, and Solid Fuel Burning Appliances", For Venting requirements.
- C. Current Edition of American Society of Mechanical Engineers ASME CSD-1, "Controls and Safety Devices for Automatically Fired Boilers", for assembly and operations of controls and safety devices.

### CANADIAN BOILERS

- A. Current Edition of Canadian Standards Association CSA B139, "Installation Code for Oil Burning Equipment", for recommended Installation Practices.

The following terms are used throughout this manual to bring attention to the presence of hazards of various risk levels, or to important information concerning product life.

### **DANGER**

Indicates an imminently hazardous situation which, if not avoided, will result in death, serious injury or substantial property damage.

### **CAUTION**

Indicates a potentially hazardous situation which, if not avoided, may result in moderate or minor injury or property damage.

### **WARNING**

Indicates a potentially hazardous situation which, if not avoided, could result in death, serious injury or substantial property damage.

### **NOTICE**

Indicates special instructions on installation, operation, or maintenance which are important but not related to personal injury hazards.

### **NOTICE**

This boiler has a limited warranty, a copy of which is printed on the back of this manual. It is the responsibility of the installing contractor to see that all controls are correctly installed and are operating properly when the installation is complete. The warranty for this boiler is valid only if the boiler has been installed, maintained and operated in accordance with these instructions.

## **DANGER**

**DO NOT store or use gasoline or other flammable vapors or liquids in the vicinity of this or any other appliance.**

## **WARNING**

**Improper installation, adjustment, alteration, service or maintenance can cause property damage, personal injury or loss of life. Failure to follow all instructions in the proper order can cause personal injury or death. Read and understand all instructions, including all those contained in component manufacturers manuals which are provided with the appliance before installing, starting-up, operating, maintaining or servicing this appliance. Keep this manual and literature in legible condition and posted near appliance for reference by owner and service technician.**

**This boiler requires regular maintenance and service to operate safely. Follow the instructions contained in this manual. Installation, maintenance, and service must be performed only by an experienced, skilled and knowledgeable installer or service agency. All heating systems should be designed by competent contractors and only persons knowledgeable in the layout and installation of hydronic heating systems should attempt installation of any boiler. It is the responsibility of the installing contractor to see that all controls are correctly installed and are operating properly when the installation is completed. Installation is not complete unless a pressure relief valve is installed into the tapping located on top of appliance - See Section III of this manual for details.**

**This boiler is not suitable for installation on combustible flooring, unless installed with a combustible floor shield (available at extra cost). Do not install boiler on carpeting.**

**Do not tamper with or alter the boiler or controls. Retain your contractor or a competent serviceman to assure that the unit is properly adjusted and maintained.**

**Have Firetubes cleaned at least once a year - preferably at the start of the heating season to remove soot and scale. The inside of combustion chamber should also be cleaned and inspected at the same time.**

**Have Oil Burner and Controls checked at least once a year or as may be necessitated.**

**Do not operate unit with jumpered or absent controls or safety devices.**

**Do not operate unit if any control, switch, component, or device has been subject to water.**

## **WARNING**

Appliance materials of construction, products of combustion and the fuel contain alumina, silica, heavy metals, carbon monoxide, nitrogen oxides, aldehydes and/or other toxic or harmful substances which can cause death or serious injury and which are known to the state of California to cause cancer, birth defects and other reproductive harm. Always use proper safety clothing, respirators and equipment when servicing or working nearby the appliance.

---

This boiler contains very hot water under high pressures. Do not unscrew any pipe fittings nor attempt to disconnect any components of this boiler without positively assuring the water is cool and has no pressure. Always wear protective clothing and equipment when installing, starting up or servicing this boiler to prevent scald injuries. Do not rely on the pressure and temperature gauges to determine the temperature and pressure of the boiler. This boiler contains components which become very hot when the boiler is operating. Do not touch any components unless they are cool.

---

This appliance must be properly vented and connected to an approved vent system in good condition. Do not operate boiler with the absence of an unapproved vent system.

---

This boiler needs fresh air for safe operation and must be installed so there are provisions for adequate combustion and ventilation air.

---

The interior of the venting and air intake systems must be inspected and cleaned before the start of the heating season and should be inspected periodically throughout the heating season for any obstructions. Clean and unobstructed venting and air intake systems are necessary to allow noxious fumes that could cause injury or loss of life to vent safely and will contribute toward maintaining the boiler's efficiency.

---

This boiler is supplied with controls which may cause the boiler to shut down and not re-start without service. If damage due to frozen pipes is a possibility, the heating system should not be left unattended in cold weather; or appropriate safeguards and alarms should be installed on the heating system to prevent damage if the boiler is inoperative.

---

This boiler is designed to burn No. 2 fuel oil only. Do not use gasoline, crankcase drainings, or any oil containing gasoline. Never burn garbage or paper in this boiler. Do not convert to any solid fuel (i. e. wood, coal) or gaseous fuel (i. e. natural gas, LP/propane). All flammable debris, rags, paper, wood scraps, etc., should be kept clear of the boiler at all times. Keep the boiler area clean and free of fire hazards.

---

Do not operate boiler on combustible floor without a factory supplied floor shield. Concrete over wood joists is considered combustible flooring. Do not operate on masonry floors, which may contain moisture.

# Tables of Contents

I. Pre-Installation .....	7	VI. Oil Piping .....	28
II. Knockdown Boiler Assembly .....	9	VII. System Start-Up .....	30
III. Water Piping and Trim .....	12	VIII. Service and Cleaning .....	36
IV. Venting .....	18	IX. Repair Parts .....	38
V. Electrical and Sequence of Operation	20		

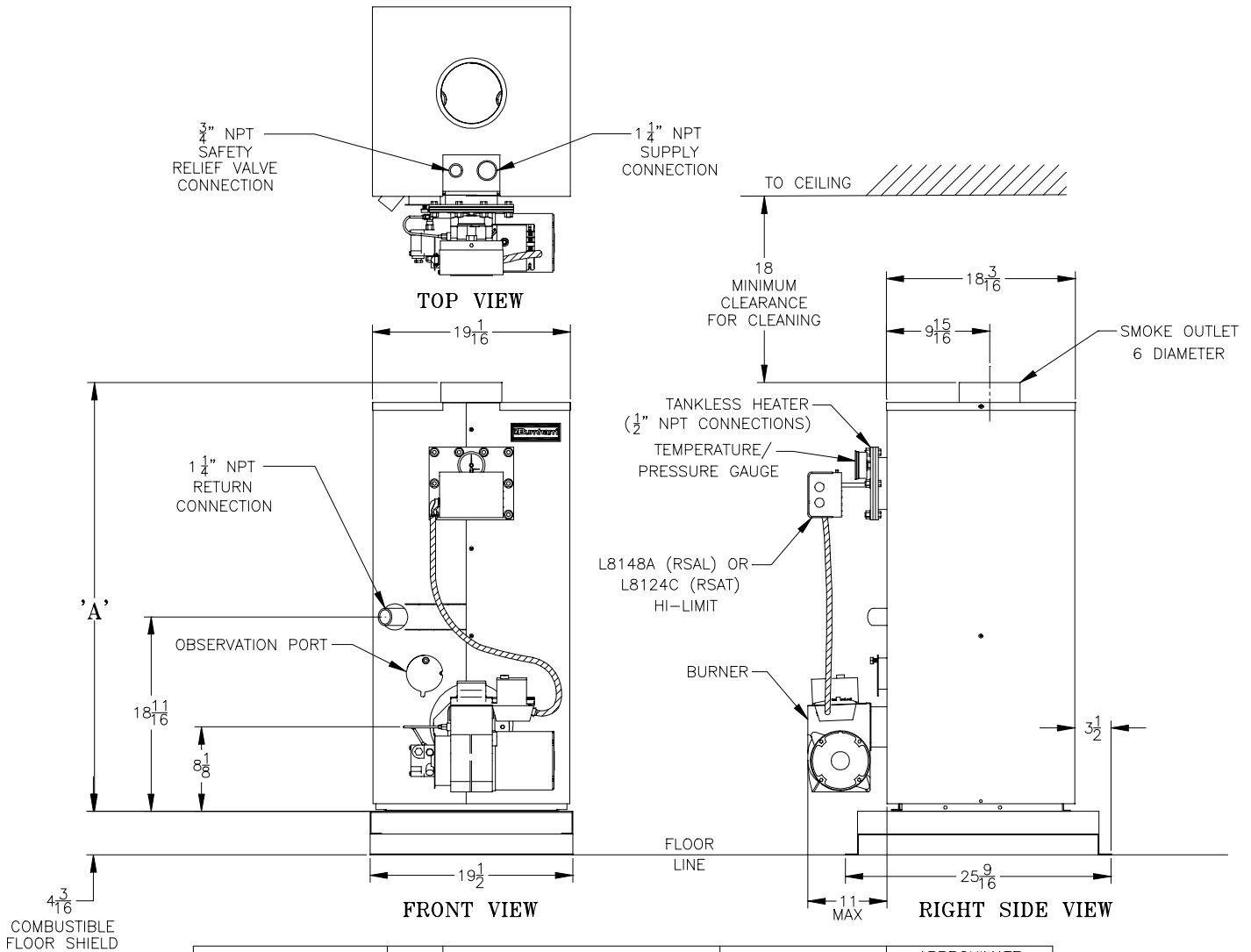

BOILER MODEL	DIM. 'A'	RECOMMENDED CHIMNEY SIZES		WATER CAPACITY (GALLONS)	APPROXIMATE SHIPPING WEIGHT (LB)
		RECTANGULAR	ROUND		
RSA-85 & RSAH-85	$34\frac{3}{4}$	8" X 8" X 20' MIN.	6" X 15' MIN.	9.1	300
RSA-110 & RSAH-110				8.5	
RSA-125 & RSAH-125	$41\frac{1}{4}$		7" X 15' MIN.	13.9	340
RSA-135 & RSAH-135				13.0	355

Figure 1: RSA Packaged Boiler (RSA85 / RSA135)

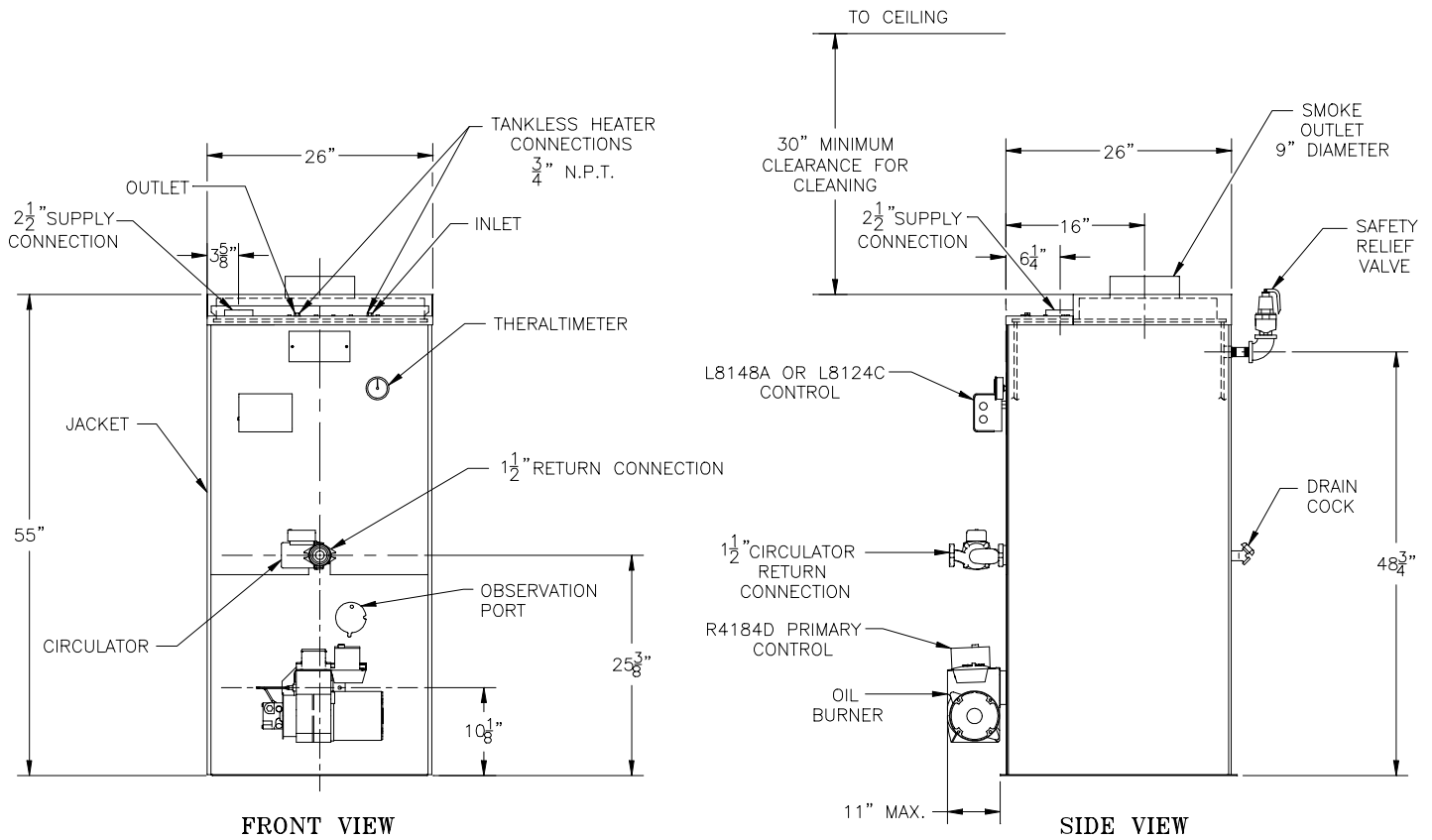

**Figure 1A: RSA Packaged Boiler (RSA170 / RSA285)**

Boiler Model Number	Bare Boiler Assembly	Minimum Chimney Sizes		Water Capacity Gallons	Approx. Shipping Weight
		In. x In. x Ft. (height)	In. (dia.) x Ft. (height)		
RSA170	WV-29-10	8 x 8 x 20	7" x 20'	42.6	600 lb.
RSA195	WV-29-13A	8 x 8 x 20	8" x 20'	39.9	630 lb.
RSA240	WV-29-16A	8 x 12 x 20	8" x 20'	37.3	660 lb.
RSA285	WV-29-19A	8 x 12 x 20	9" x 20'	34.6	690 lb.

# I. Pre-Installation

- A. INSPECT SHIPMENT** carefully for any signs of damage.
1. ALL EQUIPMENT is carefully manufactured, inspected and packed. Our responsibility ceases upon delivery of the crated boiler to the carrier in good condition.
  2. ANY CLAIMS for damage or shortage of shipment must be filed immediately against the carrier by the consignee. No claims for variances from, or shortage in orders, will be allowed by the manufacturer unless presented within sixty (60) days after receipt of goods.
- B. LOCATE BOILER** in front of final position before removing crate.

supplied by Burnham, is used. DO NOT install on carpeting.

2. FOR BASEMENT INSTALLATION, provide a solid base, such as concrete, if floor is not level, or if water may be encountered on floor around boiler.
3. PROVIDE SERVICE CLEARANCE of at least 48" from the front of the jacket for servicing of burner and removal of tankless heater.

For minimum clearances to combustible materials. See Figure 2.

1. LOCATE so that smoke pipe connection to chimney will be short and direct. BOILER IS NOT SUITABLE FOR INSTALLATION ON COMBUSTIBLE FLOOR unless combustible floor shield,

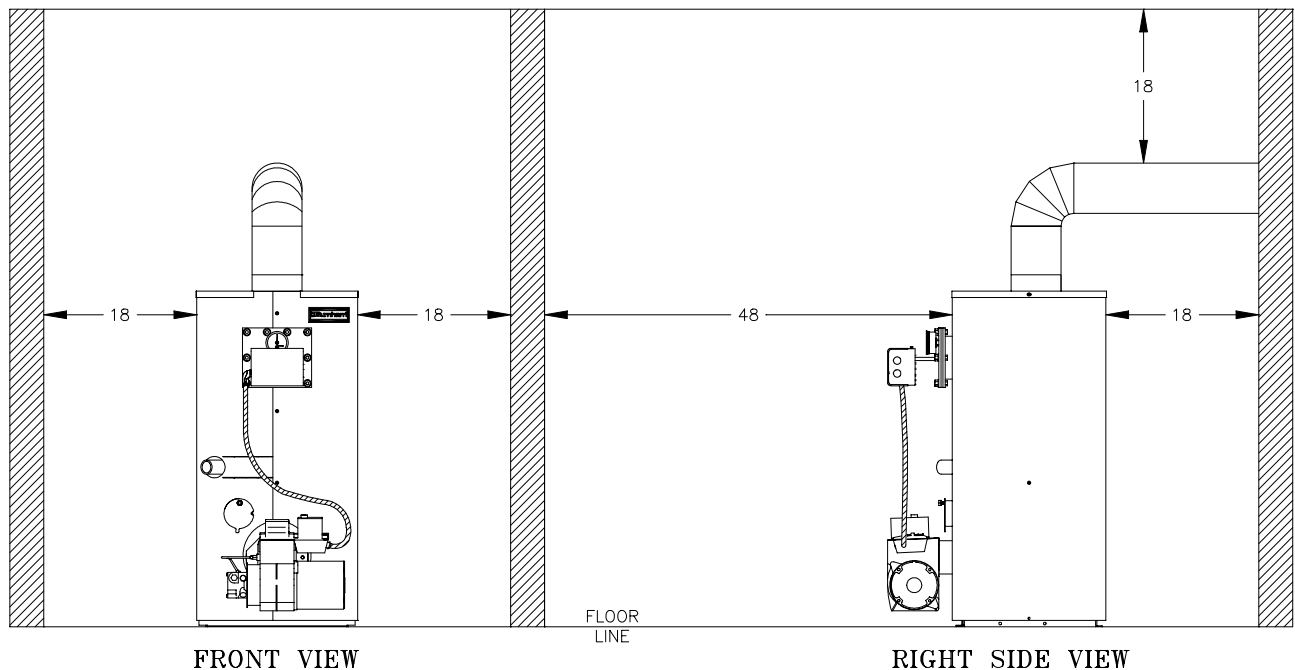

**Figure 2: Minimum Clearances to Combustible Materials**

**NOTE:**

1. Listed clearances comply with American National Standard ANSI/NFPA 31, Installation of Oil Burning Equipment.
2. RSA boilers can be installed in rooms with clearances from combustible material as listed above. Listed clearances can not be reduced for alcove or closet installations.
3. For reduced clearances to combustible material, protection must be provided as described in the above ANSI/NFPA 31 standard.

- C.** PROVIDE AIR SUPPLY AND VENTILATION to accommodate proper combustion. If natural ventilation is inadequate, provide a screened opening or duct from the boiler room to the outside. The opening or duct must be sized so the boiler input will not exceed 4,000 BTUH/Sq. In. of free area. If other air consuming appliances are near the boiler, the air inlet should be larger. Consult respective manufacturers.
- D.** VENTILATION AIR must be provided to maintain the ambient temperature at safe limits. Local and national codes may apply and should be referenced.
1. In unconfined spaces (basement) in buildings of conventional frame, brick, or stone construction, infiltration normally is adequate to provide air for ventilation.
  2. In confined spaces, two permanent openings, one near the top of the enclosure and one near the bottom, shall be provided. Each opening shall have a free area of not less than 1 sq. inch per 1000 BTUH of the total input of all appliances in the space.
- 3.** PROVIDE COMBUSTION AND VENTILATION AIR. Local code provisions may apply and should be referenced.

- A.** Determine volume of space (boiler room). Rooms communicating directly with the space in which the appliances are installed, through openings not furnished with doors, are considered a part of the space.
- $$\text{Volume(ft}^3\text{)} = \text{Length(ft)} \times \text{Width(ft)} \times \text{Height(ft)}$$
- B.** Determine total input of all appliances in the space. Add inputs of all appliances in the space and round the result to the nearest 1000 BTU per hour.
- C.** Determine type of space. Divide Volume by total input of all appliances in space. If the result is greater than or equal to 50 ft<sup>3</sup>/1000 BTU per hour, then it is considered an *unconfined space*. If the result is less

than 50 ft<sup>3</sup>/1000 BTU per hour then the space is considered a *confined space*.

- D.** For boiler located in an *unconfined space of a conventionally constructed building*, the fresh air infiltration through cracks around windows and doors normally provides adequate air for combustion and ventilation.
- E.** For boiler located in a confined space or an unconfined space in a building of unusually tight construction, provide outdoor air with the use of two permanent openings which communicate directly or by duct with the outdoors or spaces (crawl or attic) freely communicating with the outdoors. Locate one opening within 12 inches of top of space. Locate remaining opening within 12 inches of bottom of space. Minimum dimension of air opening is 3 inches. Size each opening per following:
1. **Direct communication with outdoors.** Minimum free area of 1 square inch per 4,000 BTU per hour input of all equipment in space.
  2. **Vertical ducts.** Minimum free area of 1 square inch per 4,000 BTU per hour input of all equipment in space. Duct cross-sectional area shall be same as opening free area.
  3. **Horizontal ducts.** Minimum free area of 1 square inch per 2,000 BTU per hour input of all equipment in space. Duct cross-sectional area shall be same as opening free area.
- Alternate method for boiler located within confined space.* Use indoor air if two permanent openings communicate directly with additional space(s) of sufficient volume such that combined volume of all spaces meet criteria for unconfined space. Size each opening for minimum free area of 1 square inch per 1,000 BTU per hour input of all equipment in spaces, but not less than 100 square inches.

**F.** Louvers and Grilles of Ventilation Ducts

1. All outside openings should be screened and louvered. Screens used should not be smaller than 1/4 inch mesh. Louvers will prevent the entrance of rain and snow.
2. Free area requirements need to consider the blocking effect of louvers, grilles, or screens protecting the openings. If the free area of the louver or grille is not known, assume wood louvers have 20-25 percent free area and metal louvers and grilles have 60-75 percent free area.
3. Louvers and grilles must be fixed in the open position, or interlocked with the equipment to open automatically during equipment operation.



## II. Knock-Down Boiler Assembly

### A. REMOVAL OF BOILER.

1. Remove, all boiler to skid, hold down fasteners.  
Refer to Figure 3.
2. Carefully walk boiler to the edge of skid. Tilt the boiler back, allowing an edge to rest on the floor, and remove the skid.

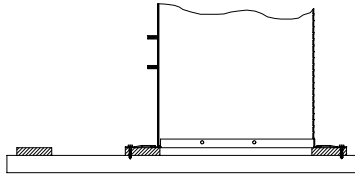

Figure 3: Base on Skid

### B. TEST HEAT EXCHANGER FOR LEAKS before proceeding with jacket assembly. Heat exchanger, canopy, and base are preassembled.

1. Install pressure gauge supplied, a hose to the city water and a valve in the supply tapping. Plug remainder of tappings.
2. Fill boiler with water and apply a pressure of at least 10 psig but no more than 30 psig.

### H. INSTALLING THE JACKET

1. Before jacket can be secured to boiler assembly tankless heater coil or blank plate must be attached. Using rubber gasket and bolts provided secure heater coil or blank plate to boiler extension by inserting the bolts from the backside of the extension. Refer to Figure 4.

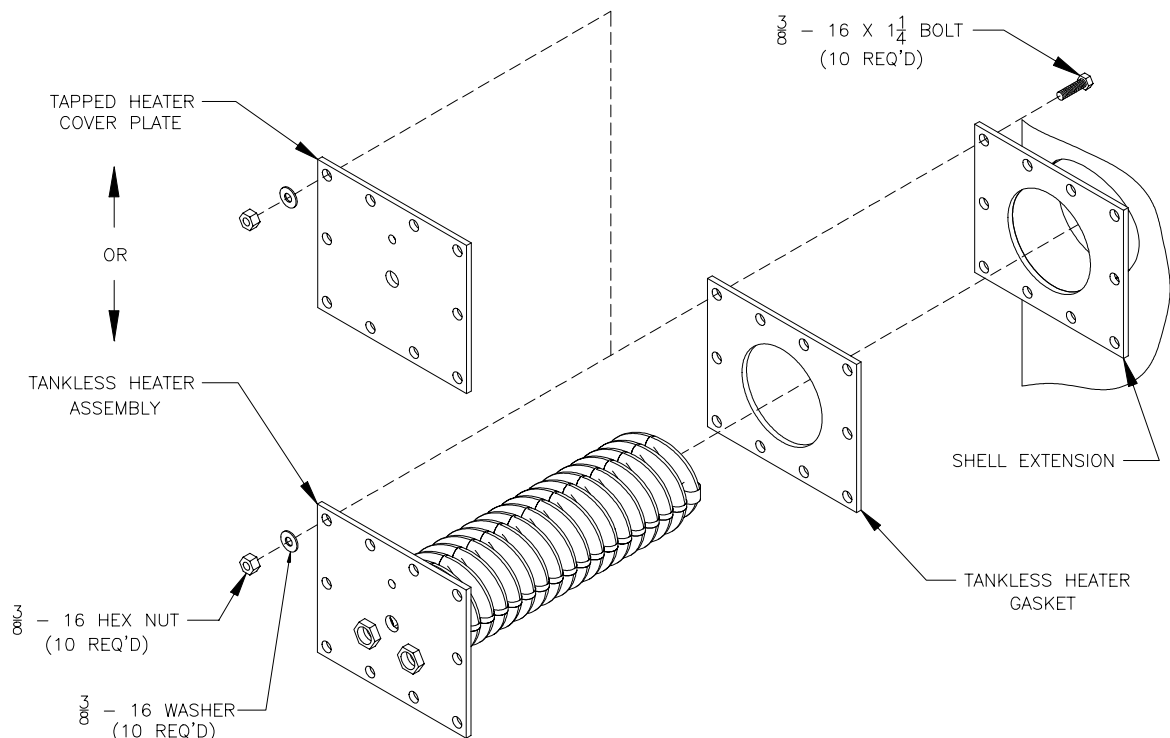
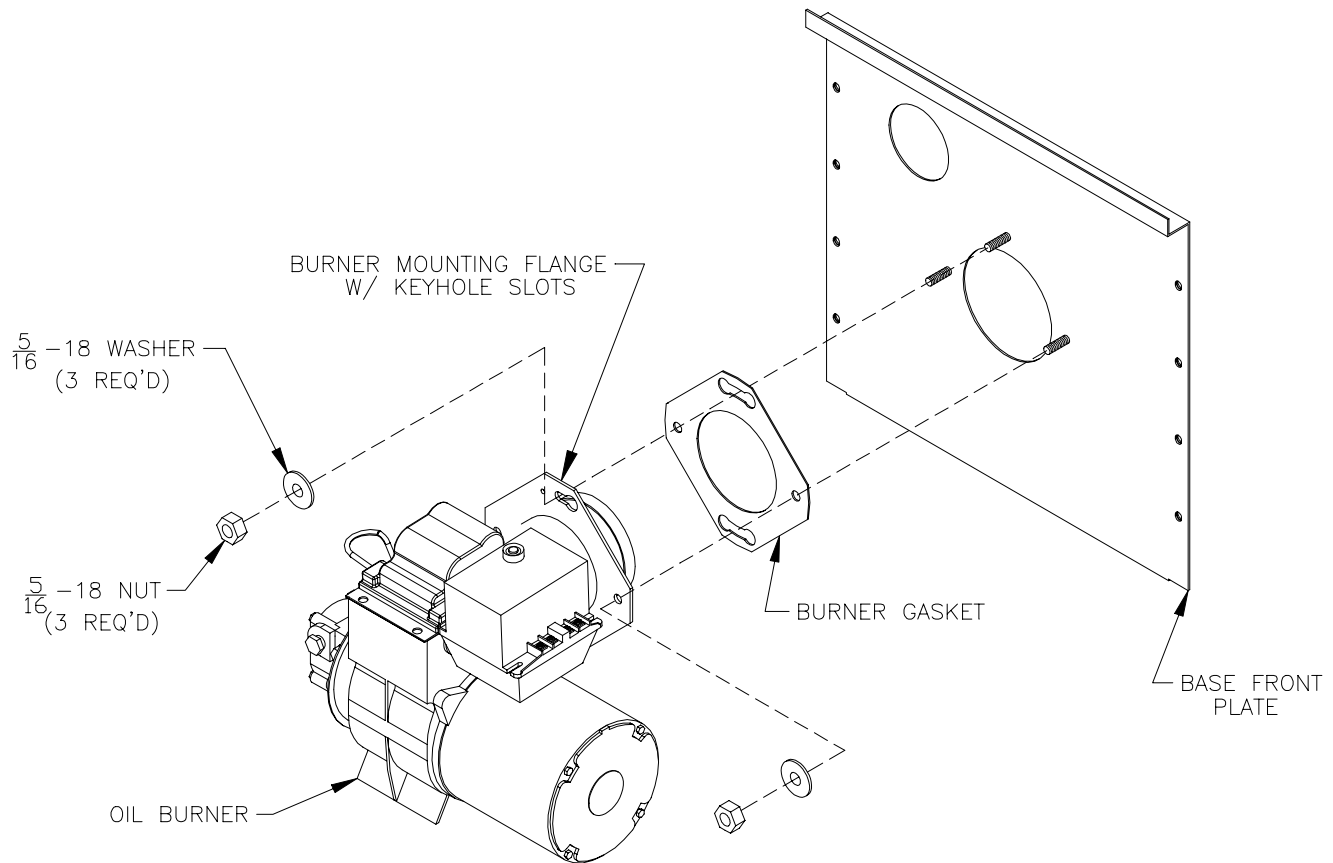

Figure 4: Coil Plate Attachment

2. Bend jacket according to Figure 6. Starting from the front, wrap the jacket around the boiler. Make sure that return pipe, observation port and shell extension fit proper into there corresponding clearance holes. Continue bending jacket around until front panels meet.
3. Attach jacket to boiler assembly with provided screws at appropriate locations. Make sure that the jacket is at least ½" to ¾" off of the floor before attaching.
4. Attach top panel with provided screws.

## I. INSTALLATION OF BOILER CONTROLS

1. Install provided pressure/temperature gauge and immersion well into appropriate holes on tankless heater coil plate. Tighten so not to have any water leaks.
2. Mount the aquastat control onto the immersion well. Wire the control according to Figure 14 or 15, in the Electrical and Sequence of Operation Section.
3. Mount burner on Base front panel and wire according to instructions provided with the burner. Refer to Figure 5.



**Figure 5: Burner Mounting**

11

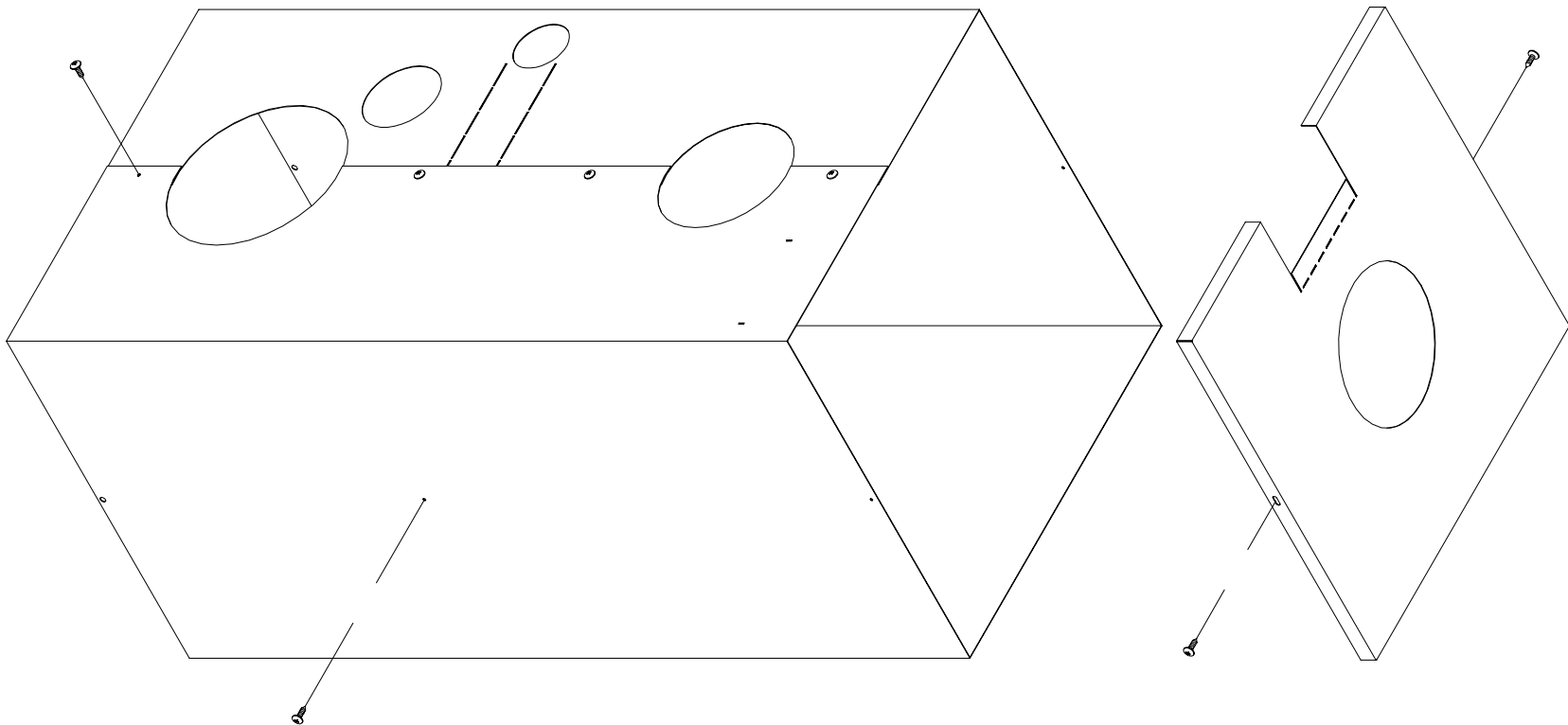

Figure 6: RSA Jacket Assembly

### III. Water Piping and Trim

#### WARNING

Failure to properly pipe boiler may result in improper operation and damage to boiler or structure.

Oxygen contamination of boiler water will cause corrosion of iron and steel boiler components, and can lead to boiler failure. Burnham's Standard Warranty does not cover problems caused by oxygen contamination of boiler water or scale (lime) build-up caused by frequent addition of water.

- A. Design a piping system and install boiler which will prevent oxygen contamination of boiler water and frequent water additions.
1. There are many possible causes of oxygen contamination such as:
    - a. Addition of excessive make-up water as a result of system leaks.
    - b. Absorption through open tanks and fittings.
    - c. Oxygen permeable materials in the distribution system.
  2. In order to insure long product life, oxygen sources should be eliminated. This can be accomplished by taking the following measures:
    - a. Repairing system leaks to eliminate the need for addition of make-up water.
    - b. Eliminating open tanks from the system.
    - c. Eliminating and/or repairing fittings which allow oxygen absorption.
    - d. Use of non-permeable materials in the distribution system.
    - e. Isolating the boiler from the system water by installing a heat exchanger.

#### WARNING

System supply and return piping must be connected to correct boiler pipe.

Burnham recommends sizing the system circulator to supply sufficient flow (GPM) to allow a 20°F temperature differential in the system. When sizing the system circulator, the pressure drop of all radiators, baseboard and radiant tubing and all connecting piping must be considered.

3. Connect System supply and return piping to boiler. See Figures 8 and 9. Also, consult I=B=R Installation and Piping Guides. Maintain minimum ½

inch clearance from hot water piping to combustible materials.

- a. If this boiler is used in connection with refrigeration systems, the boiler must be installed so that the chilled medium is piped in parallel with the heating boiler using appropriate valves to prevent the chilled medium from entering the boiler. See Figure 7. Also, consult I=B=R Installation and Piping Guides.
- b. If this boiler is connected to heating coils located in air handling units where they may be exposed to refrigerated air, the boiler piping must be equipped with flow control valves to prevent gravity circulation of boiler water during the operation of the cooling system.
- c. If boiler is used with an Alliance™ Indirect-Fired Domestic Water Heater, install the Alliance™ as a separate heating zone. Refer to the Alliance™ Installation, Operating, and Service Instructions for additional information.
- d. Use a system bypass if the boiler is to be operated in a system which has a large volume or excessive radiation where low boiler water temperatures may be encountered (i.e. converted gravity circulation system, etc.) The bypass should be the same size as the supply and return lines with valves located in the bypass and return line as illustrated in Figure 10 in order to regulate water flow for maintenance of higher boiler water temperature. Set the bypass and return valves to a half throttle position to start. Operate boiler until the system water temperature reaches its normal operating range. Adjust the valves to maintain 180°F to 200°F boiler water temperature and greater the 120°F return temperature. Adjust both valves simultaneously. Closing the boiler return valve while opening the bypass valve will raise the boiler return temperature. Opening the boiler return valve while closing the by-pass valve will lower the boiler return temperature.
- e. A water boiler installed above radiation level must be provided with a low water cutoff device as part of the installation.

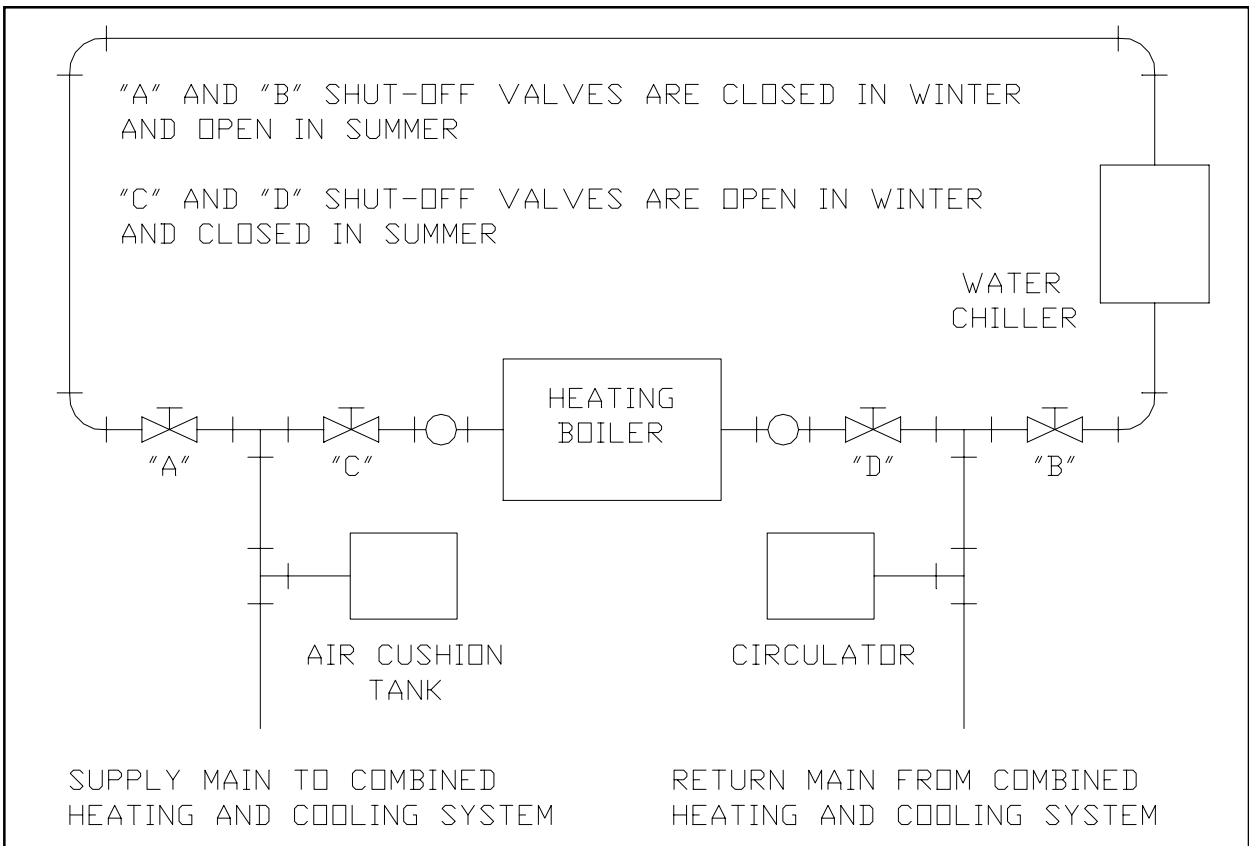

**Figure 7: Recommended Piping for Combination Heating and Cooling (Refrigeration) System**

- B.** Install Pressure Relief Valve. See Figures 8 and 9. Pressure Relief Valve must be installed with spindle in the vertical position. Installation of the relief valve must be consistent with ANSI/ASME Boiler and Pressure Vessel Code, Section IV.
- C.** Install Drain Valve in return piping. See Figures 8 and 9.
- D.** Oil, grease, and other foreign materials which accumulate in new hot water and a new or reworked system should be boiled out, and then thoroughly flushed. A qualified water treatment chemical specialist should be consulted for recommendations regarding appropriate chemical compounds and concentrations which are compatible with local environmental regulations.
- E.** After the boiler and system have been cleaned and flushed, and before refilling the entire system add appropriate water treatment chemicals, if necessary, to bring the pH between 7 and 11.

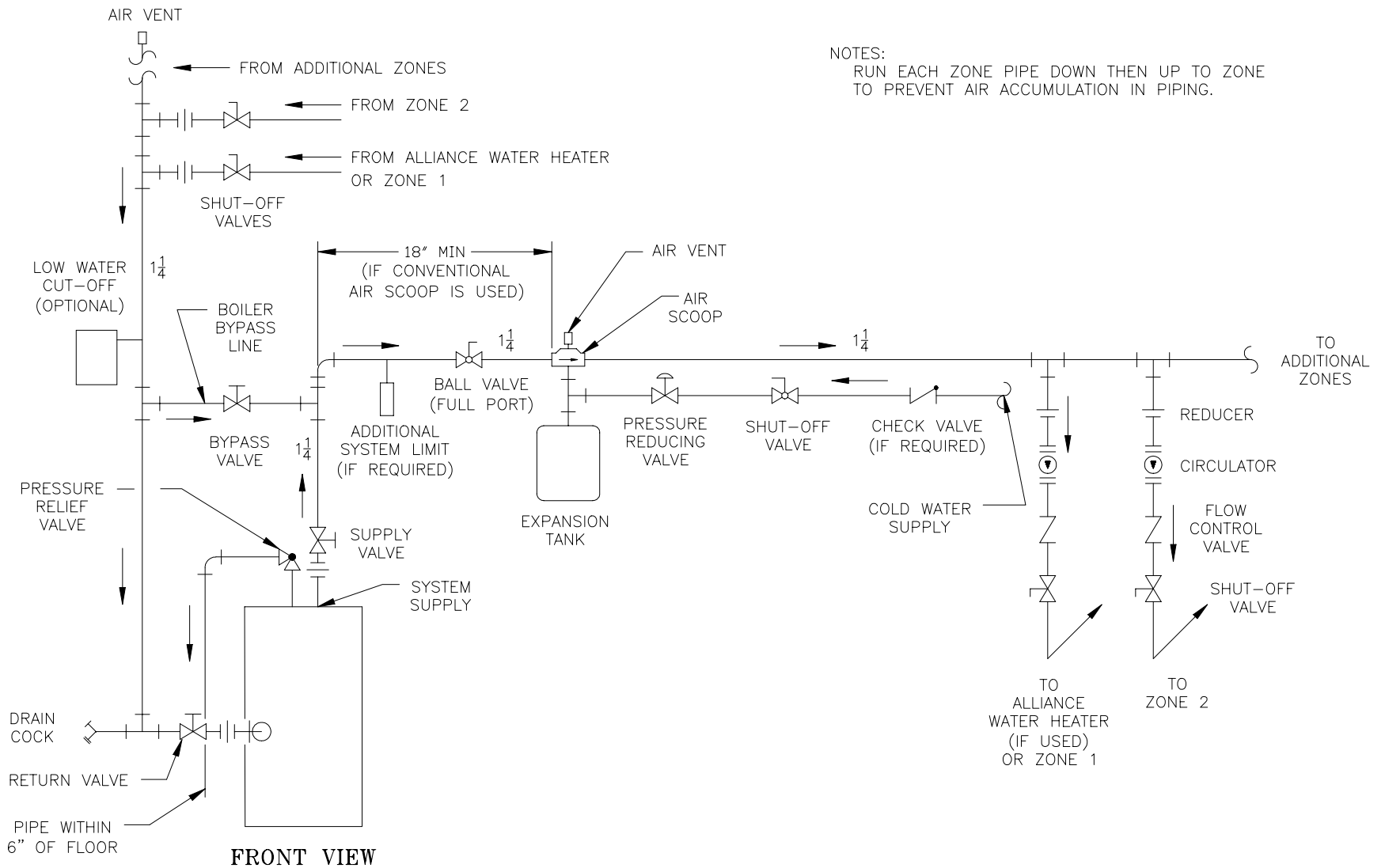

Figure 8: Recommended Boiler Piping for Circulator Zoned Heating Systems

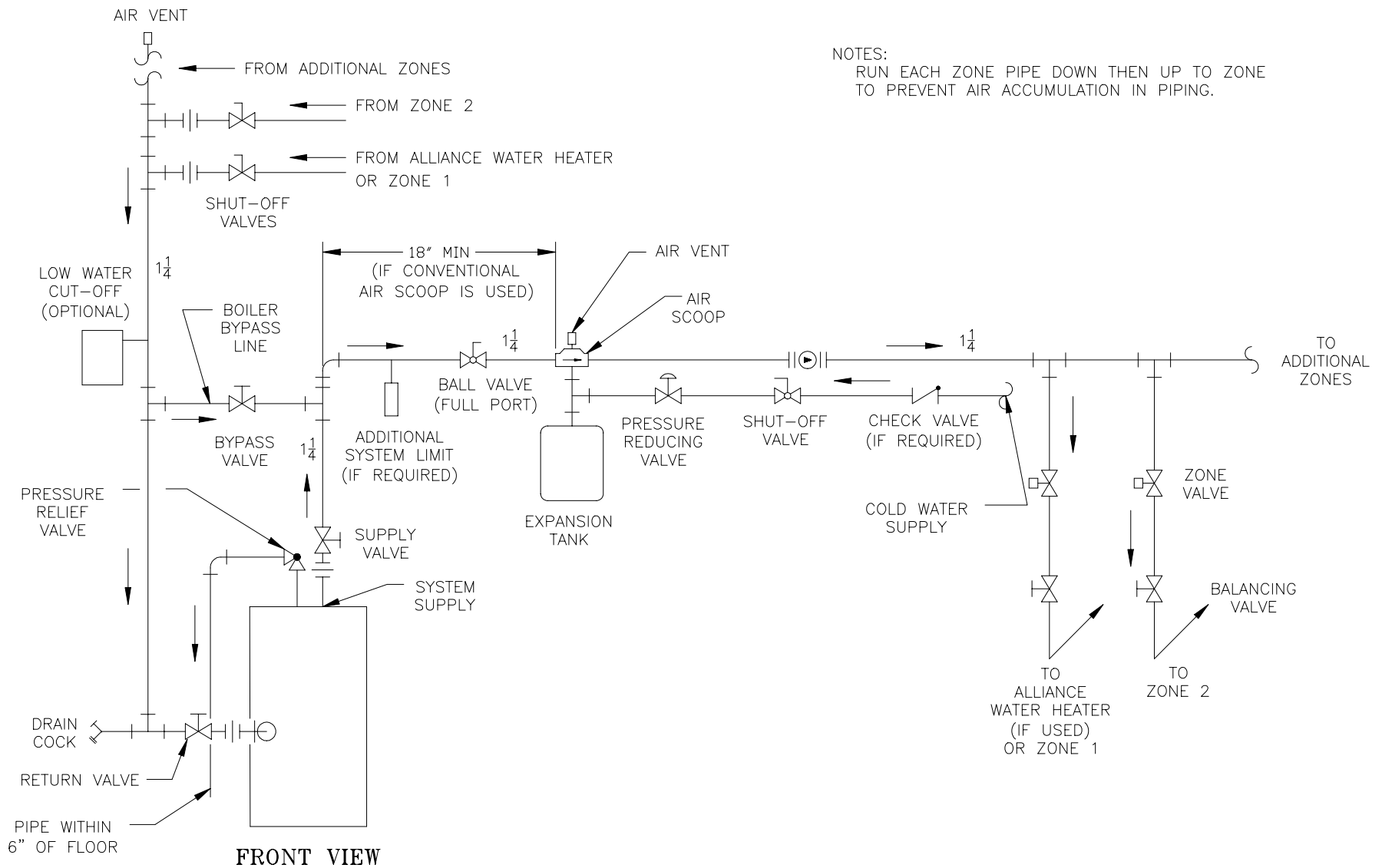

Figure 9: Boiler Piping for Zone Valve Zoned Heating Systems

**F. CONNECT TANKLESS HEATER PIPING AS SHOWN IN FIGURE 11.** See Table 1 for Tankless Heater Rating.

**WARNING**

**Install automatic mixing valve at tankless heater outlet to avoid risk of burns or scalding due to excessively hot water at fixtures. Adjust and maintain the mixing valve in accordance with the manufacturer's instructions. Do not operate tankless heater without mixing valve.**

THE FOLLOWING GUIDELINES SHOULD BE FOLLOWED WHEN PIPING THE TANKLESS HEATER:

1. **FLOW REGULATION** — If flow through the heater is greater than its rating, the supply of adequate hot water may not be able to keep up with the demand. For this reason a flow regulator matching the heater rating should be installed in the cold water line to the heater. The flow regulator should preferably be located below the inlet to the heater and a minimum of 3' away from the inlet so that the regulator is not subjected to excess temperatures that may occur during “off” periods when it is possible for heat to be conducted back through the supply line. The flow regulator also limits the flow of supply water regardless of inlet pressure variations in the range of 20 to 125 psi.

2. **TEMPERING OF HOT WATER** — Installation of an automatic mixing valve will lengthen the delivery of the available hot water by mixing some cold water with the hot. This prevents the possibility of scalding hot water at the fixtures. In addition, savings of hot water will be achieved since the user will not waste as much hot water while seeking a water temperature. Higher temperature hot water required by dishwashers and automatic washers is possible by piping the hot water from the heater prior to entering the mixing valve. The mixing valve should be “trapped” by installing it below the cold water inlet to heater to prevent lime formation in the valve. Refer to Figure 11.
3. **FLUSHING OF HEATER** — All water contains some sediment which settles on the inside of the coil. Consequently, the heater should be periodically backwashed. This is accomplished by installing hose bibs as illustrated and allowing water at city pressure to run into hose bib A, through the heater, and out hose bib B until the discharge is clear. The tees in which the hose bibs are located should be the same size as heater connections to minimize pressure drop.
4. **HARD WATER** — A water analysis is necessary to determine the hardness of your potable water. This is applicable to some city water and particularly to well water. An appropriate water softener should be installed based on the analysis and dealer’s recommendation. This is not only beneficial to the tankless heater but to piping and fixtures plus the many other benefits derived from soft water.

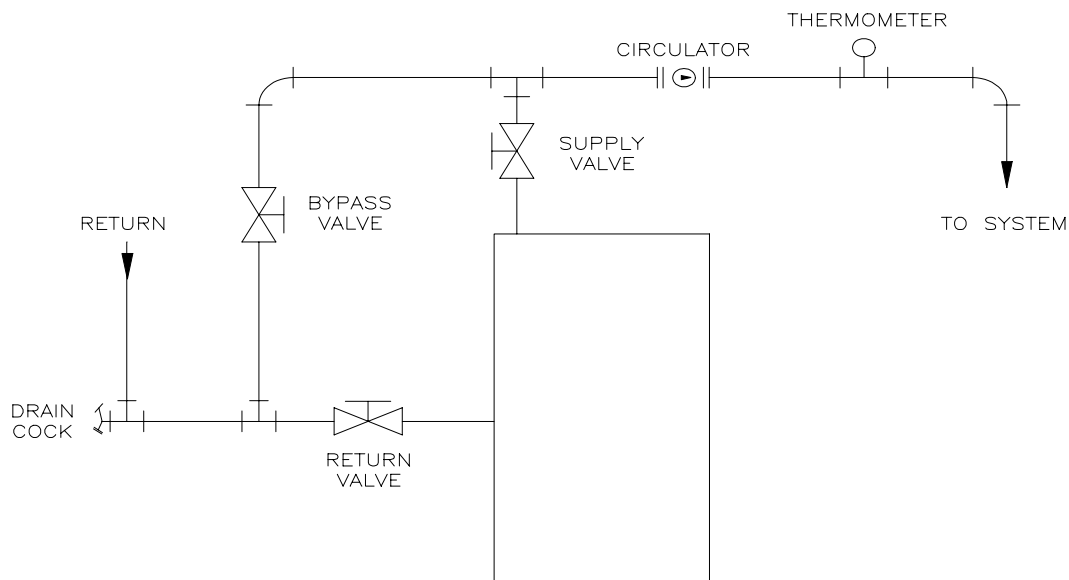

**Figure 10: Recommended System Bypass Piping**



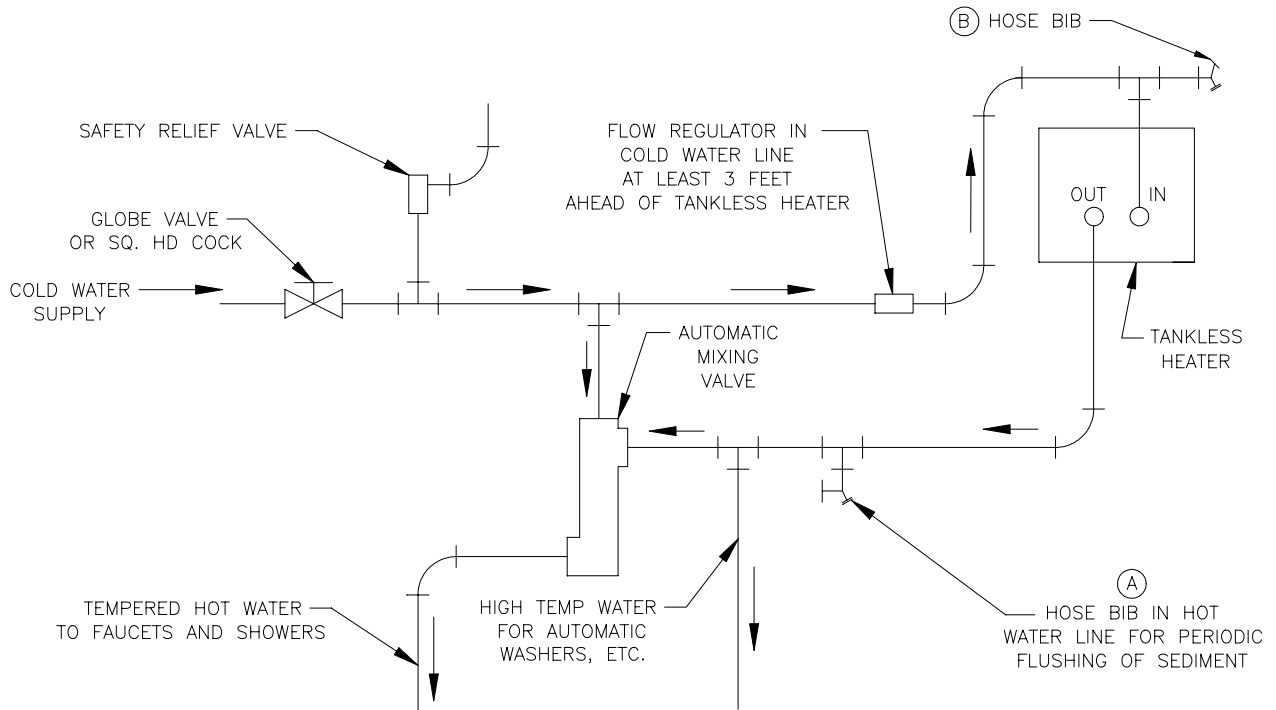

**Figure 11: Schematic Tankless Heater Piping**

**Table 1: Tankless Heater Ratings**

Boiler Model	S350		S375	
	GPM	PSID	GPM	PSID
RSA(H)85 & 110	3	12	3½	15
RSA110(H)125 & 135	3¼	16	3¾	25
RSA125 & 135	3½	19		

Boiler Model	STD. #7524		OPT. #7530	
	GPM	PSID	GPM	PSID
RSA170	3¾	25½	4	26½
RSA195, 240, & 285	4	29	4¼	31

---

## IV. Venting

---

### A. General Guidelines.

1. Vent system installation must be in accordance with these instructions and applicable provisions of local building codes. Contact local building or fire officials about restrictions and installation inspection in your area.
2. The RSA Series is designed to be vented into a fireclay tile-lined masonry chimney or chimney constructed from type-L vent or a factory built chimney that complies with the type HT requirements of UL103. The chimney or vent pipe shall have a sufficient draft at all times, to assure safe proper operation of the boiler. See Figure 12 for recommended installation.
  - a. Install a draft regulator (supplied by installer) following the instructions furnished with the regulator. See Figure 13 for alternate regulator locations.
  - b. With any new or replacement installation the chimney has to be considered. Chimneys that have a high heat loss become less suitable as the heat loss of the home goes down and the efficiency of the boiler goes up. Most homes have a chimney appropriate for the fuel and the era in which the home was built. That may have been a coal fired or an inefficient oil fired boiler built into a home without insulation or storm windows. With increasing fuel prices that home probably has been insulated and fitted with storm windows so that the heat loss of the home has been reduced. This requires less fuel to be burned and sends less heat up the chimney. A new boiler probably has a higher efficiency

than the boiler being replaced. That probably means that the stack temperature from the new boiler will be lower than that from the old boiler and with less room air being drawn up the chimney to dilute the stack gases. The combination of a large uninsulated chimney, reduced firing rate, reduced firing time, lower stack temperature and less dilution air can, in some cases, contribute to the condensing of small amounts of water vapor in the chimney. Such condensation, when it occurs, can cause chimney deterioration. In extreme cases, the chimney may have to be lined to insulate the chimney and thus prevent the condensation. The addition of dilution air into the chimney may assist in drying the chimney interior surfaces. A massive chimney on a cold, or exposed outside wall may have produced adequate draft when it was fired with a higher input and greater volumes of heated gases. With reduced input and volume, the draft may be severely affected. In one instance our research showed a new chimney of adequate sizing produced only - .035" W.C. after 30 minutes of continuous firing at 13.0% CO<sub>2</sub>. Outside wall chimneys take longer to heat up and can have .00" W.C. draft at burner start-up. You may have to consider a special alloy chimney flue liner with insulation around it and stabilizing draft cap or even a draft inducing fan in severe cases.

- c. For the same reasons as in (2.) above, heat extractors mounted into the breeching are not recommended.
3. For minimum clearances to combustible materials refer to Figure 2.

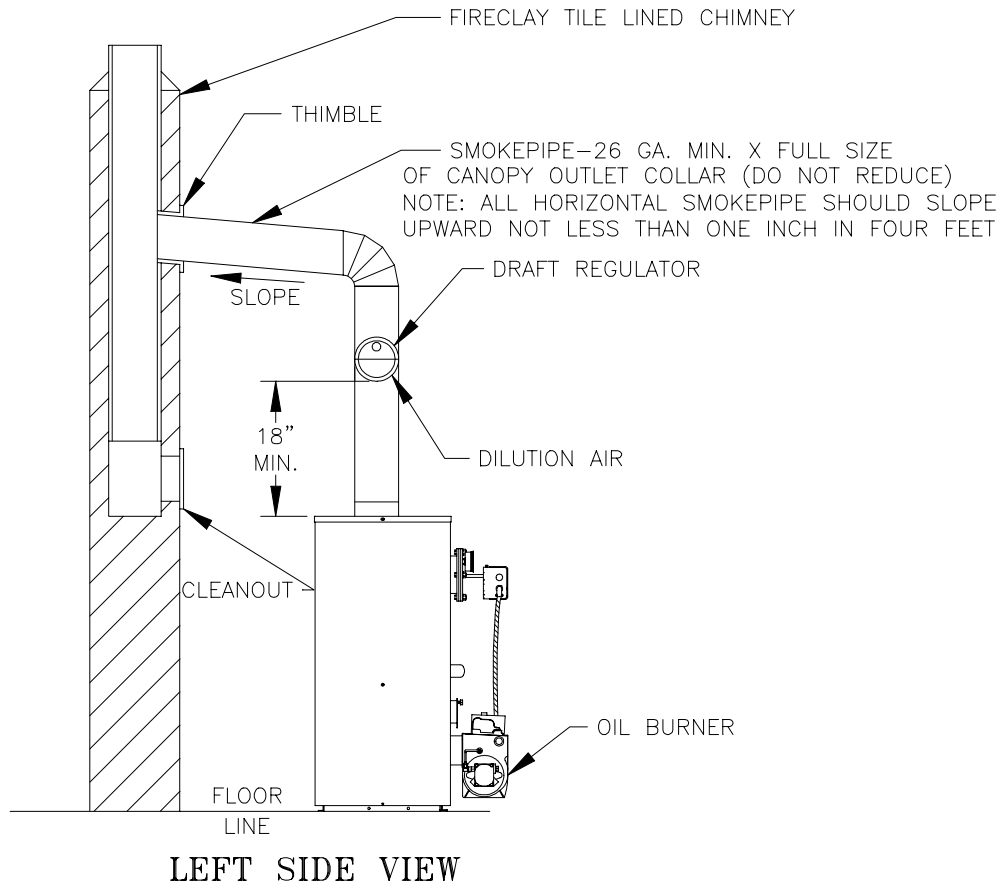

**Figure 12: Recommended Smokepipe Arrangement and Chimney Requirements**

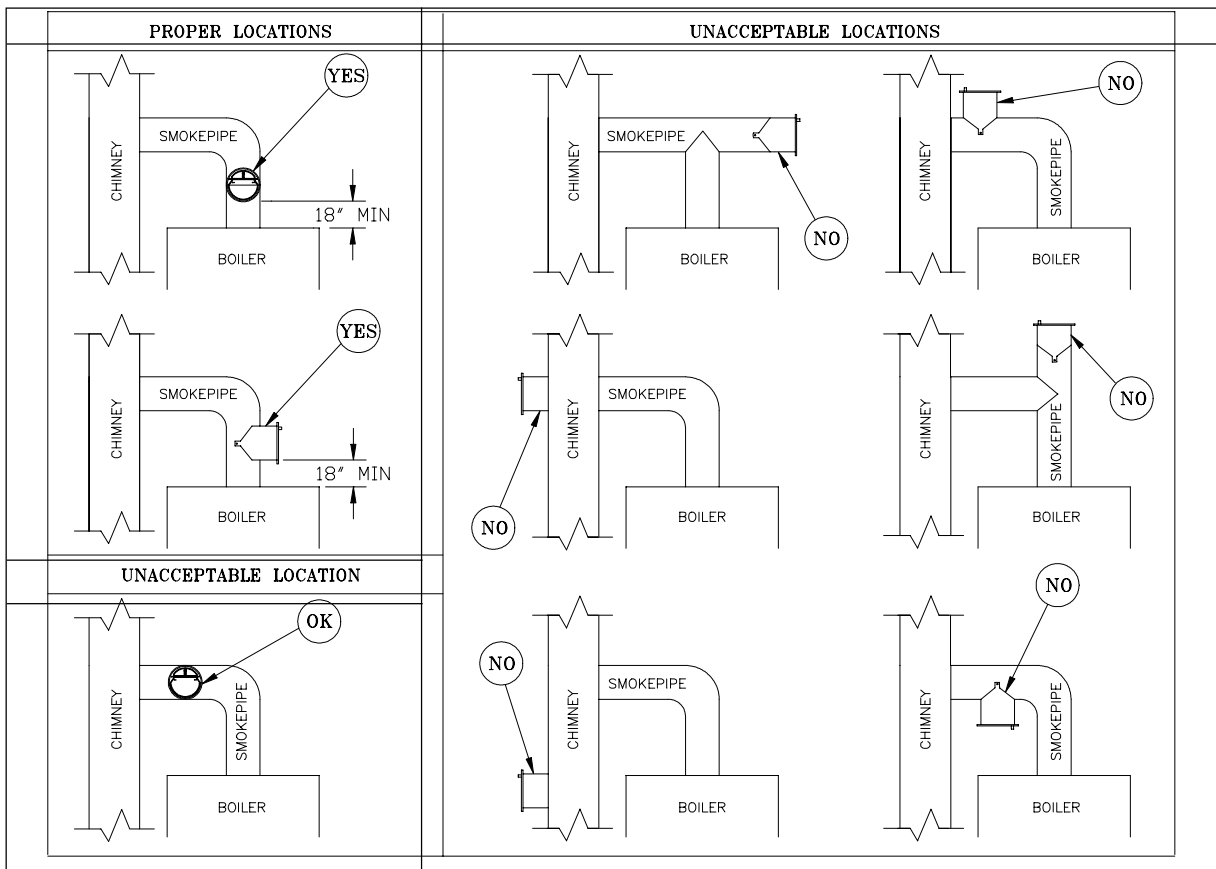

**Figure 13: Draft Regulator Locations**

## V. Electrical

### DANGER

**Positively assure all electrical connections are unpowered before attempting installation or service of electrical components or connections of the boiler or building. Lock out all electrical boxes with padlock once power is turned off.**

### WARNING

**Failure to properly wire electrical connections to the boiler may result in serious physical harm.**

**Electrical power may be from more than one source. Make sure all power is off before attempting any electrical work.**

**Each boiler must be protected with a properly sized fused disconnect.**

**Never jump out or make inoperative any safety or operating controls.**

**The wiring diagrams contained in this manual are for reference purposes only. Refer to the wiring diagram of any controls used with the boiler. Read, understand and follow all wiring instructions supplied with the controls.**

#### A. General

1. Install wiring and electrically ground boiler in accordance with requirements of the authority having jurisdiction, or in absence of such requirements the National Electrical Code, ANSI/NFPA 70, and/or the CSA C22.1 Electric Code.
2. A separate electrical circuit should be run from the main electrical service with a fused disconnect switch in the circuit.
3. Wiring should conform to Figure 14 and/or 15.

#### B. System Controls and Wiring

1. Refer to National Electric Code or Local Electric Codes for proper size and type of wire required. Follow Code.
2. Use anti-short bushings on all wiring passing through boiler jacket, junction boxes and/or control boxes.
3. Use armored cable (BX) over all exposed line voltage wiring.
4. If an Alliance indirect water heater is used, use priority zoning. Do not use priority zoning for Hydro-Air Systems.
5. Single Zone System – Refer to Figure 14 or 15 of

this manual for the electrical diagram for this type of system. Connect the system circulator wire leads to the proper locations on the Aquastat control, L8124C/L8148A. See Figure 14 or 15. Connect the thermostat to the ‘T-T’ terminals on the L8124C/L8148A control. Set thermostat heat anticipator settings to 0.60 amps.

6. Conventional Circulator Zoned System – Refer to Figure 16 of this manual for the electrical diagram for this type of system. Read, understand and follow all of the instructions provided with the Honeywell R8888 control.
7. Conventional Zone Valve Zoned System – Refer to Figure 17. Wiring to the most popular models of zone valves are given in Figure 18. Locate C1 and C2 inside the L8124C Honeywell control. Connect the two (2) terminals to the system circulator wire leads, supplied with boiler. Connect the H1 and H2 terminals inside the R8889 to the ‘T-T’ terminals in the L8124C Honeywell Control. Refer to Figure 17. Connect the thermostat of each zone and the circulator for that zone to R8889 panel. If an Alliance indirect water heater is used, connect the Alliance thermostat and circulator to the Zone 1 terminals of the R8889. Set thermostat anticipator settings to 0.12 amps.

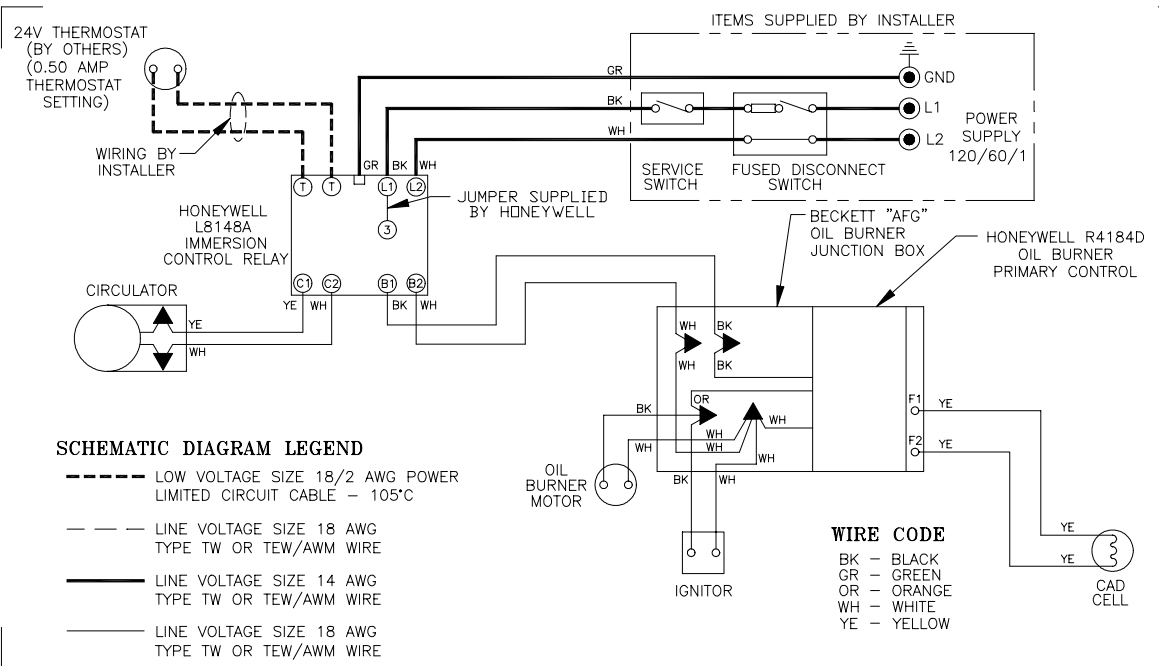

**NOTES:**

1. IF ANY OF THE ORIGINAL WIRE AS SUPPLIED WITH THE APPLIANCE MUST BE REPLACED, IT MUST BE REPLACED WITH WIRE AS SHOWN OR ITS EQUIVALENT.

**Figure 14: "RSAL" Wiring Less Tankless, Single Circulator**

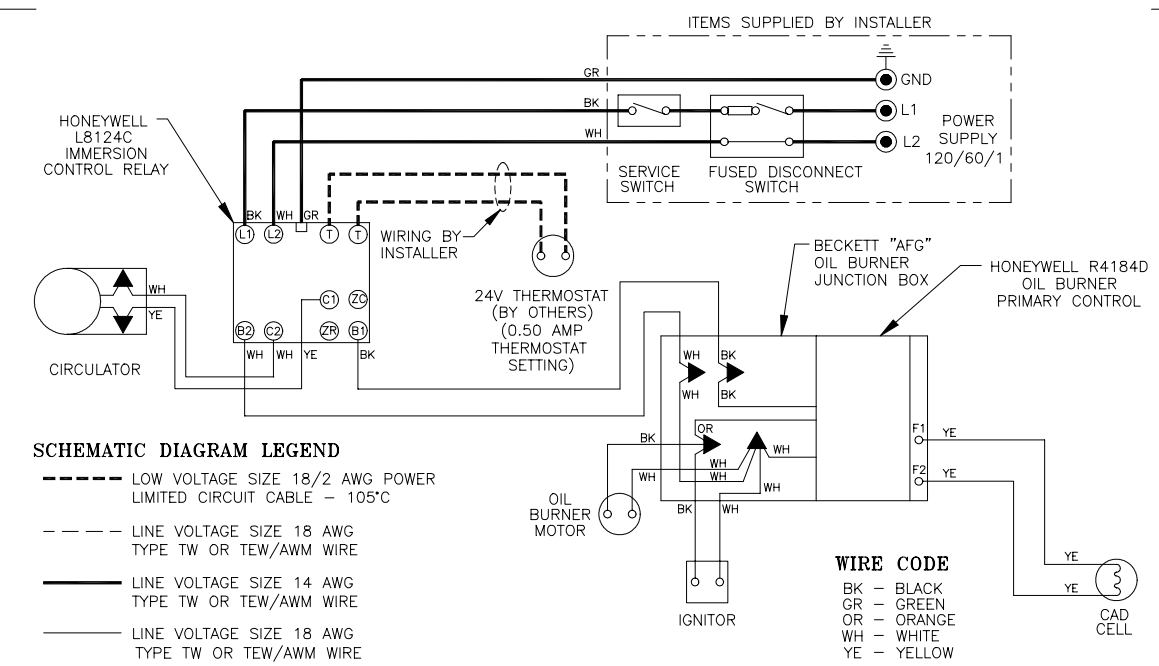

**NOTES:**

1. IF ANY OF THE ORIGINAL WIRE AS SUPPLIED WITH THE APPLIANCE MUST BE REPLACED, IT MUST BE REPLACED WITH WIRE AS SHOWN OR ITS EQUIVALENT.

**Figure 15: "RSAT" or "RSAR" Wiring with Tankless, Single Circulator**

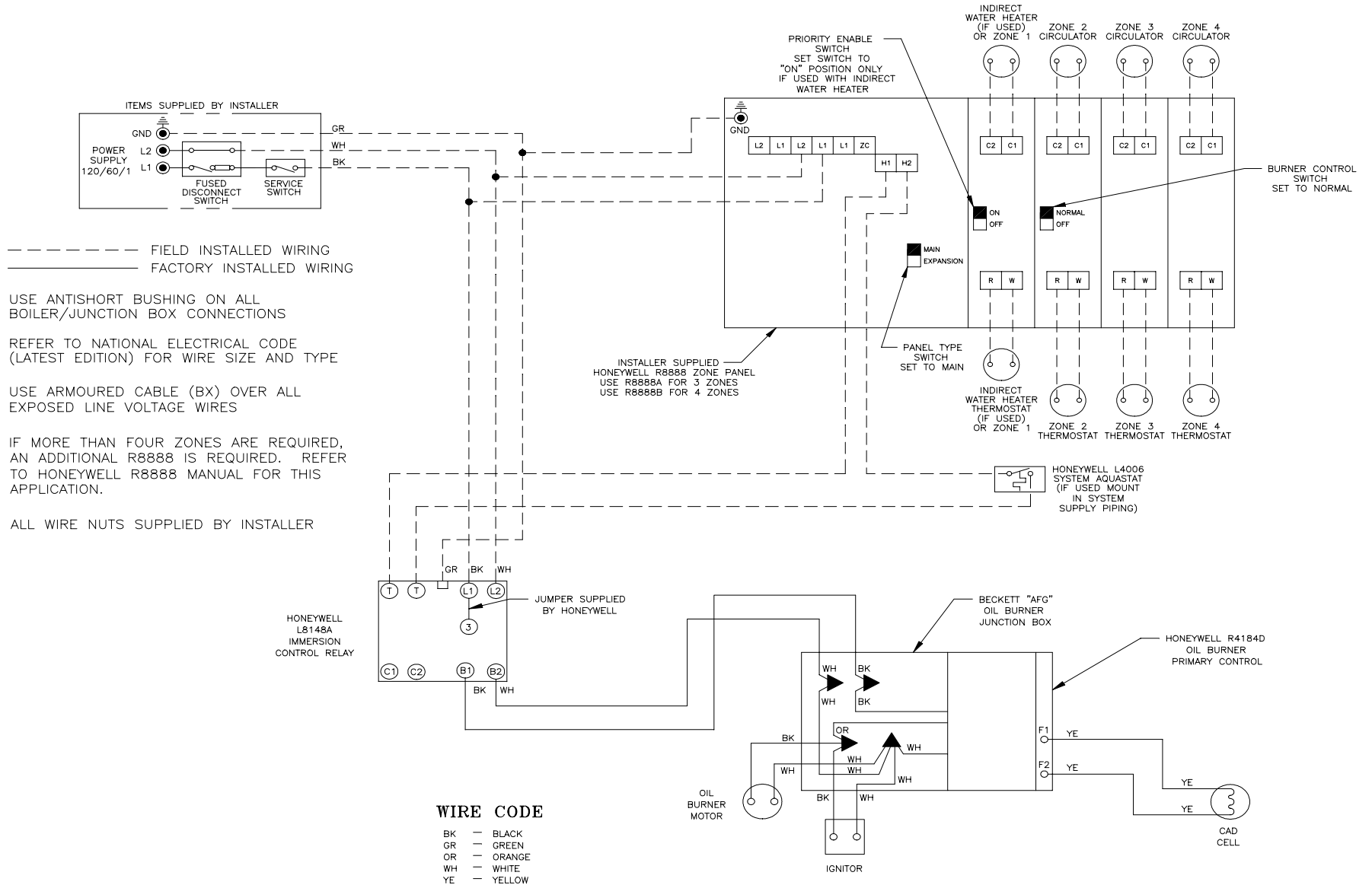

Figure 16: Circulator Zoned Wiring for Honeywell R8888

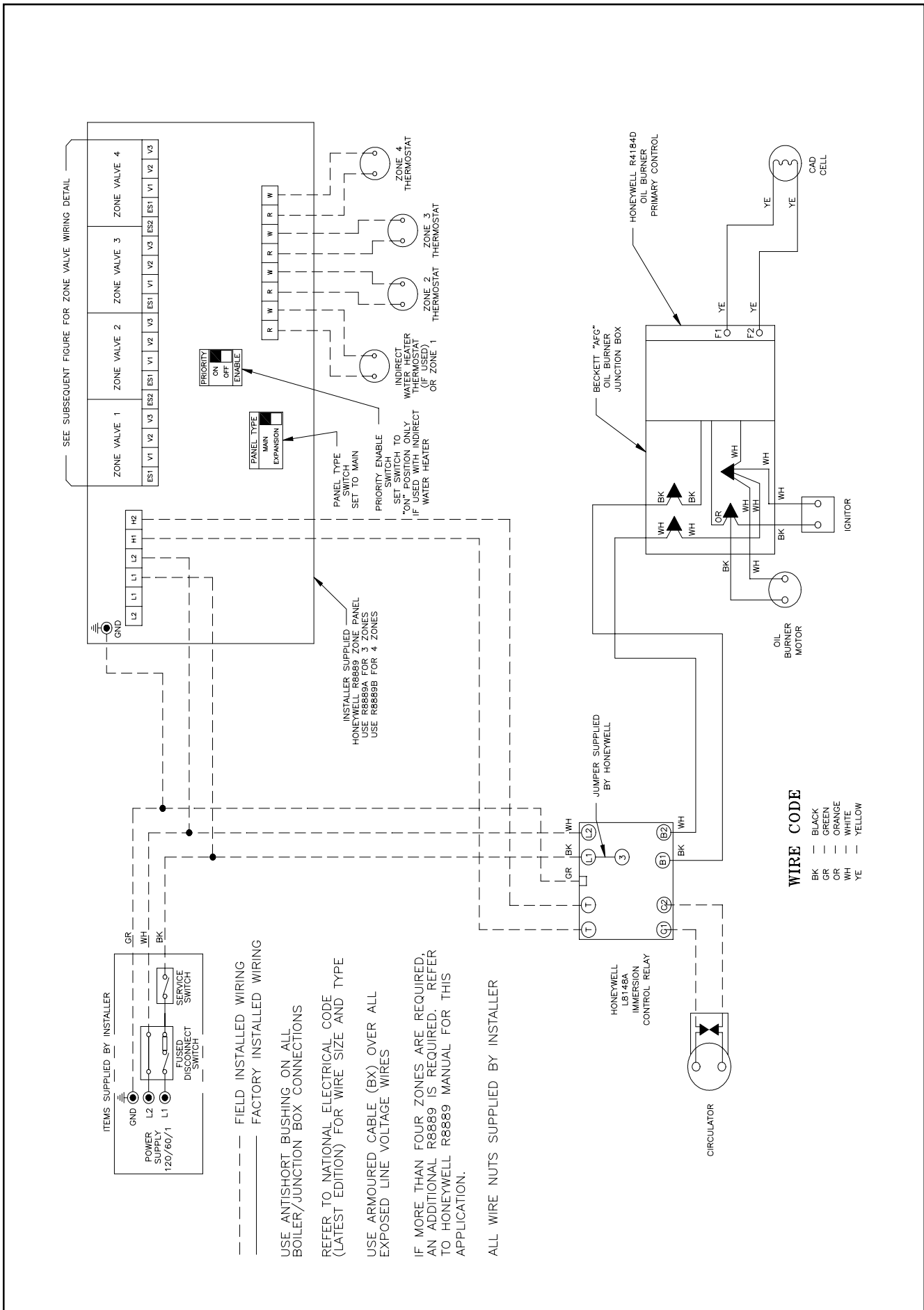
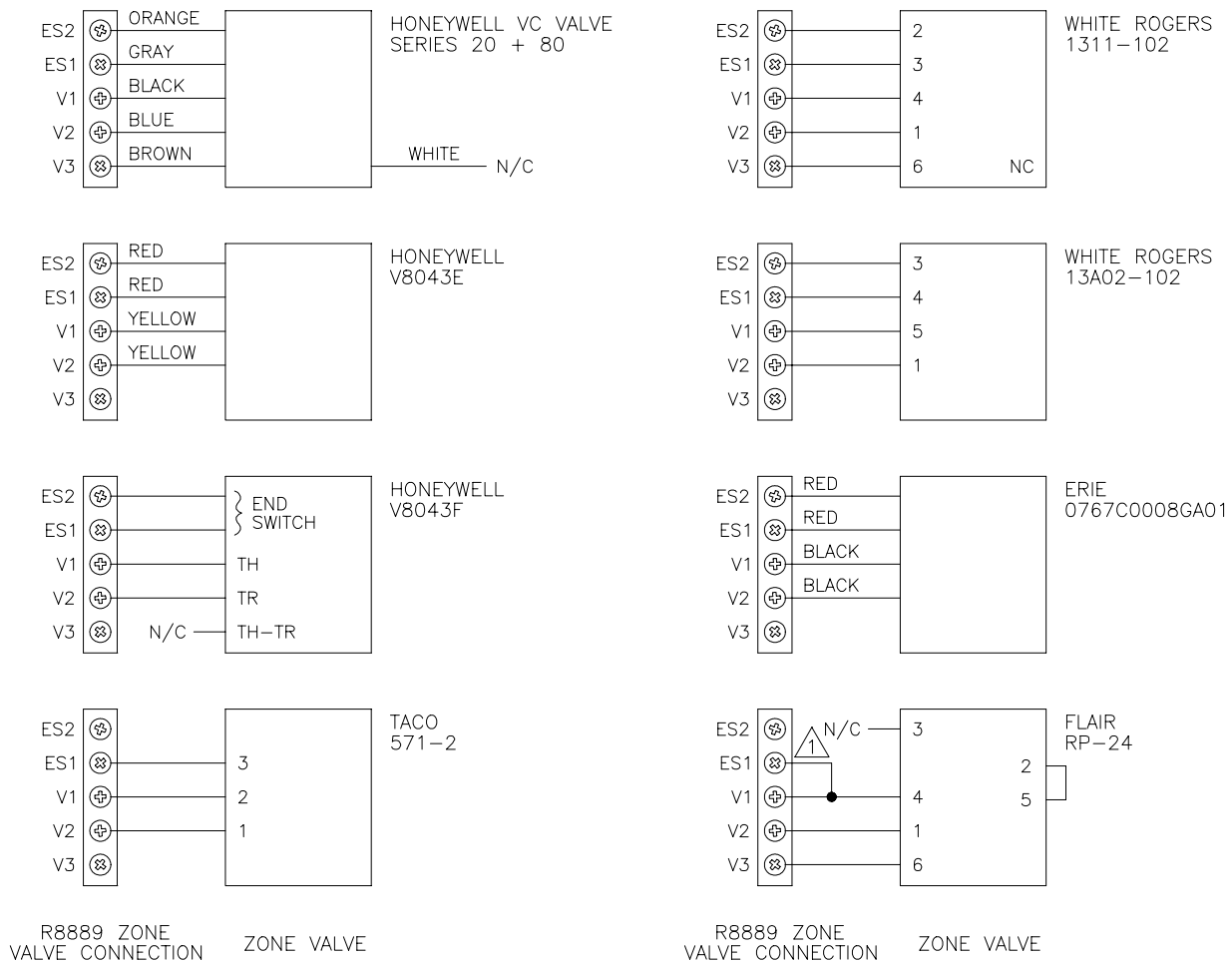

Figure 17: Zone Valve Zoned Wiring for R8889

# NOTICE

The Honeywell R8889 Control is available in two three (3) zone models and two four (4) zone models. Burnham recommends using Model R8889A for three (3) zone systems and Model R8889B for four (4) zone systems. Models R8889C and R8889D have less load capacity and may not operate with certain types of zone valves. Up to four (4) R8889's may be used together to provide up to sixteen (16) individual zones. Only one (1) zone, the first zone of the main control will provide priority zoning for the Alliance indirect water heater. If more than four (4) zones are required, connect additional R8889's by wiring the A, B and C terminals of each control together. Each R8889 requires a 120 volt power supply. If more than one (1) R8889 is used, set the panel type switch to "main" on the first R8889 and set the panel type switch to "expansion" on the second, third or fourth R8889.



JUMPER V1 TO ES1 WHEN USING ZONE VALVES WITHOUT END SWITCHES.

**Figure 18: Different Manufacturer's Zone Valve Connections to Honeywell R8889**



## NOTICE

**The Burnham EC5000 Control includes a water temperature sensor. Mount this sensor to the system supply piping.**

8. Burnham EC5000 Circulator Zoned System – Refer to Figure 19 of this manual for the electrical diagram for this type of system. Wire the system as indicated in that diagram. Refer to the manual provided with the Burnham EC5000 Control for control operation and setup details.
9. Burnham EC5000 Zone Valve Zoned System – Refer to Figure 20 of this manual for the electrical diagram for this type of system. Wire the system as indicated in that diagram. Refer to the manual provided with the Burnham EC5000 for control operation and setup details.

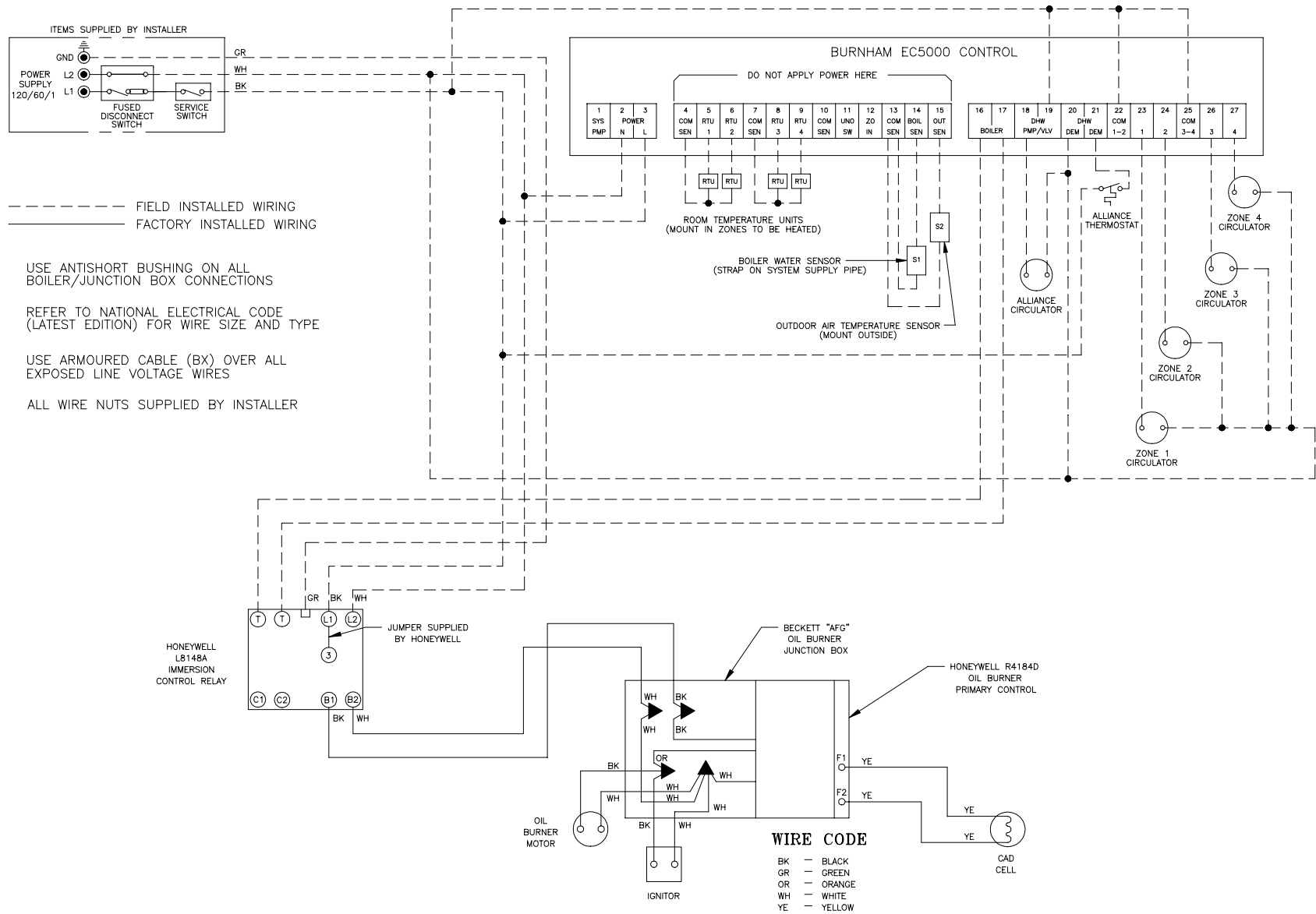

Figure 19: Circulator Zoning with EC5000 Wiring Schematic

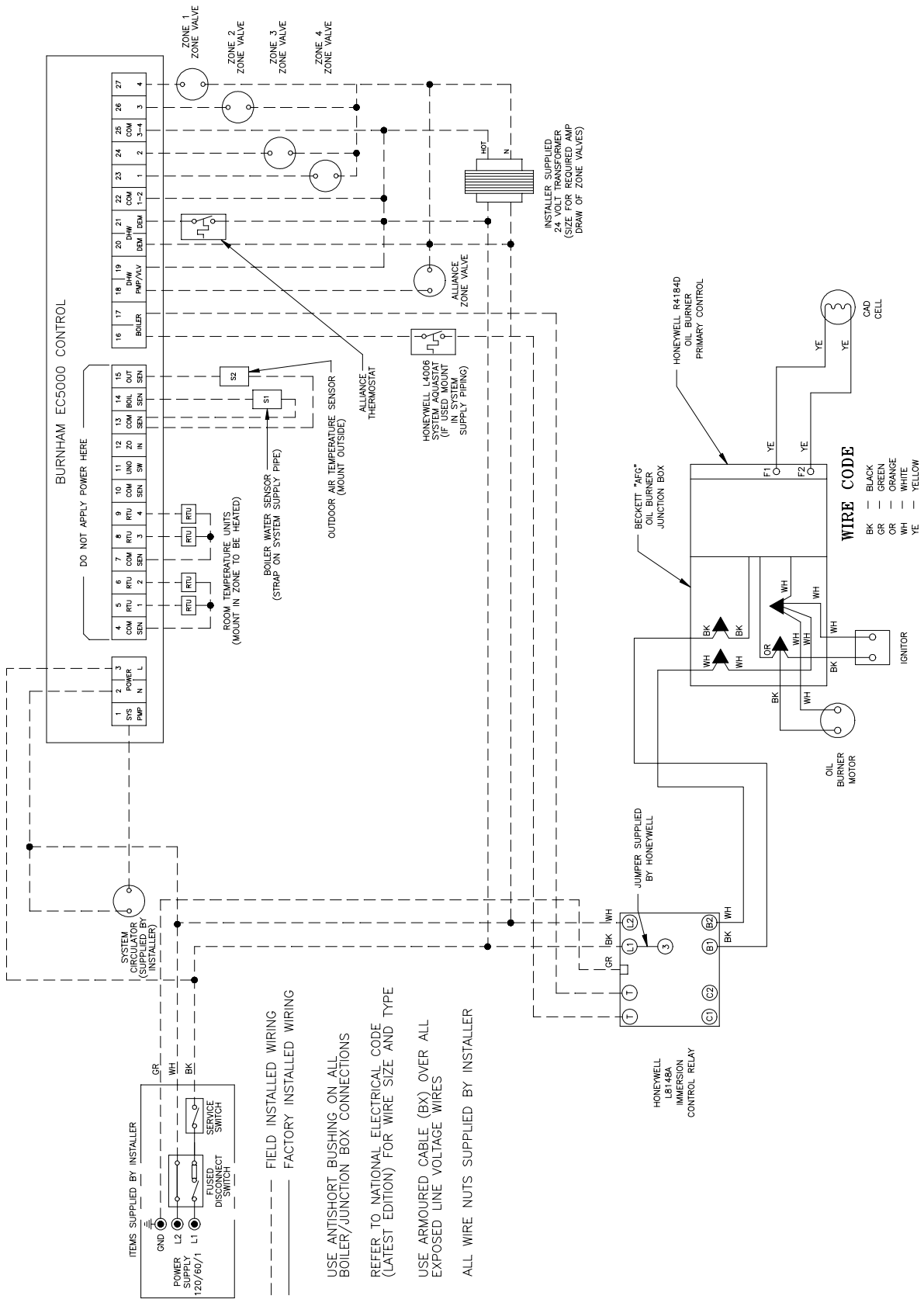

Figure 20: Zone Valve Zoned with EC5000 Wiring Schematic

## VI. Oil Piping

### A. General.

1. Use flexible oil line(s) so that burner can be removed without disconnecting the oil supply.
2. A supply line fuel oil filter is recommended as a minimum for all firing rates but a pleated paper fuel oil filter is recommended for the lowest firing rate application to prevent nozzle fouling.
3. Use Flared fittings only. Do not use compression fittings.
4. Use of a high efficiency micron filter (Garber or equivalent) in addition to conventional filter is highly recommended.

### B. Single-pipe Oil Lines.

1. Standard burners are provided with single-stage 3450 rpm fuel units with the bypass plug removed for single-pipe installations.
2. The single-stage fuel unit may be installed single-pipe with gravity feed or lift. Maximum allowable lift is 8 feet. See Figure 21.

## NOTICE

**Oil piping must be absolutely airtight or leaks or loss of prime may result. Bleed line and fuel unit completely.**

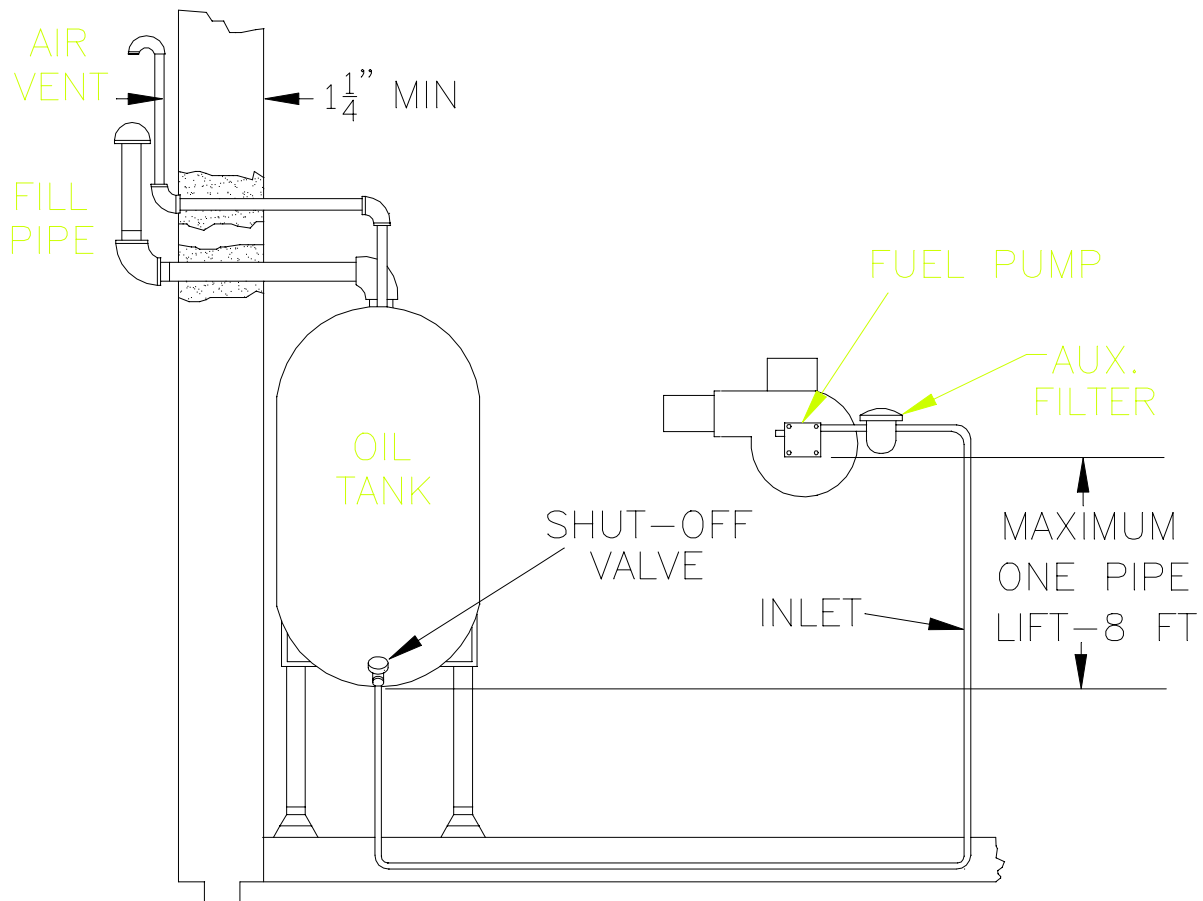

**Figure 21: Single-Pipe Installation**

TABLE 2: SINGLE STAGE UNITS (3450 RPM) TWO PIPE SYSTEMS		
Lift "H" (See Figure)	Maximum Length of Tubing "H" + "R" (See Figure)	
	3/8" OD Tubing (3 GPH)	1/2" OD Tubing (3 GPH)
0'	84'	100'
1'	78'	100'
2'	73'	100'
3'	68'	100'
4'	63'	100'
5'	57'	100'
6'	52'	100'
7'	47'	100'
8'	42'	100'
9'	36'	100'
10'	31'	100'
11'	26'	100'
12'	21'	83'
13'	---	62'
14'	---	41'

TABLE 3: TWO-STAGE UNITS (3450 RPM) TWO-PIPE SYSTEMS		
Lift "H" (See Figure)	Maximum Length of Tubing "H" + "R" (See Figure)	
	3/8" OD Tubing	1/2" OD Tubing
0'	93'	100'
2'	85'	100'
4'	77'	100'
6'	69'	100'
8'	60'	100'
10'	52'	100'
12'	44'	100'
14'	36'	100'
16'	27'	100'
18'	---	76'

C. Two-Pipe Oil Lines

1. For two-piped systems, where more lift is required, the two-stage fuel unit is recommended. Table 2 (single-stage) and Table 3 (two-stage) show allowable lift and lengths of 3/8 inch and 1/2 inch OD tubing for both suction and return lines. Refer to Figure 22.

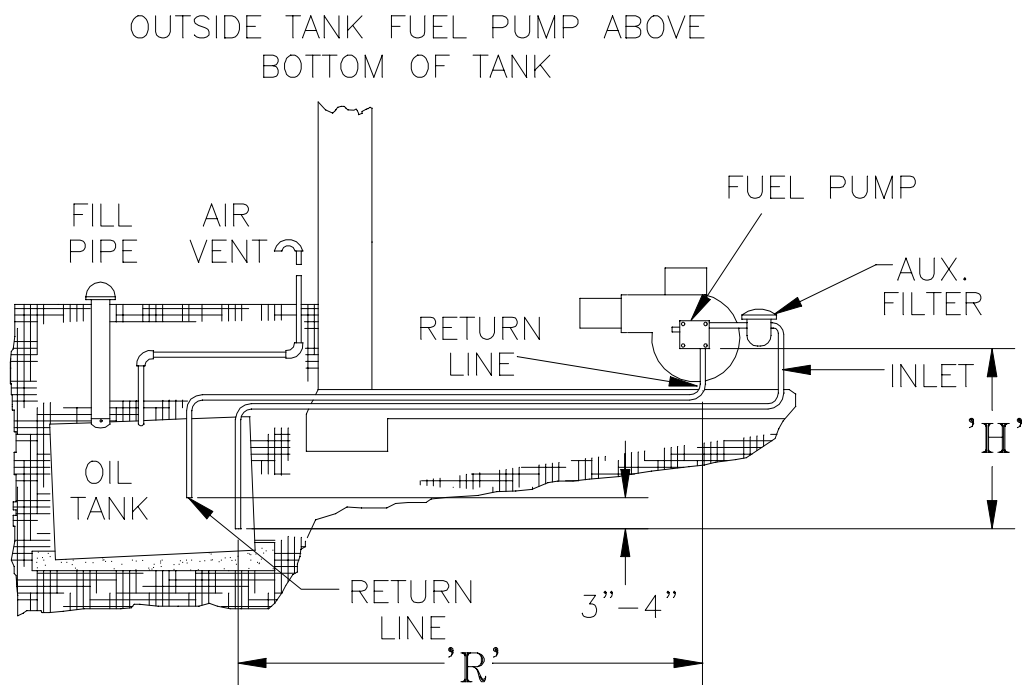

Figure 22: Two-Pipe Installation

---

## VII. System Start-Up

---

- A.** Verify that the venting, water piping, oil piping, and electrical system are installed properly. Refer to installation instructions contained in this manual.
- B.** Confirm all electrical, water and oil supplies are turned off at the source and that the vent is clear from obstructions.
- C.** Fill entire heating system with water and vent air from system. Use the following procedure on a Series Loop or multi-zoned system installed as per Figure 8 or 9.
1. Close isolation valve in boiler supply piping.
  2. Isolate all circuits by closing zone valves or balancing valves.
  3. Attach a hose to bib cock located just below isolation valve in boiler supply piping. (Note - Terminate hose at a suitable floor drain or outdoor area).
  4. Starting with one circuit at a time, open zone valve or valve.
  5. Open bib cock.
  6. Open fill valve (Make-up water line should be located directly after isolation valve in boiler supply piping between air scoop and expansion tank).
  7. Allow water to flow into drain until discharge from hose is bubble free for 30 seconds.
  8. When zone is completely purged of air, close zone valve or balancing valve. Open the zone valve for the next zone to be purged. Repeat this step until all zones have been purged. At completion, open all zone valves or valves.
  9. Close bib cock, continue filling the system until the pressure gauge reads 12 psig. Close fill valve. (Note - If make-up water line is equipped with pressure reducing valve, system will automatically fill to 12 psig.
  10. Open isolation valve in boiler supply piping.
  11. Remove hose from bib cock.
- D.** CONFIRM that the boiler and system have no water leaks.
- E.** CHECK CONTROLS, WIRING AND BURNER to be sure that all connections are tight and burner is rigid. Verify that all electrical connections have been completed, fuses installed, that the oil tank is filled and oil lines have been tested.
- F.** LUBRICATION. Follow instruction on burner and circulator label to lubricate, if oil lubricated. Most motors currently used on residential type burners employ permanently lubricated bearings and thus do not require any field lubrication. Water lubricated circulators do not need field lubrication.
- G.** SET CONTROLS with burner service switch turned "OFF".
1. SET ROOM THERMOSTAT about 10° above room temperature.
  2. PRESS RED RESET BUTTON on R4184D Oil Primary Control and release.
  3. SET HIGH LIMIT dial on L8124C/L8148A at temperature to suit requirements of installation.
- H.** REMOVE GUN ASSEMBLY
1. Check nozzle size, head size, gun setting, and positioning of electrodes. This information is shown in Figure 23, and Tables 4 and 4A.
  2. Reinstall gun assembly.
- I.** VERIFY OIL BURNER SETTINGS BEFORE STARTING
1. BURNER AIR BAND AND AIR SHUTTER SETTINGS, see Tables 4 and 4A.
  2. OPEN ALL OIL LINE VALVES.
  3. Attach a plastic hose to fuel pump vent fitting and provide a container to catch the oil.
  4. REMOVE GAUGE PORT PLUG from fuel pump and install pressure gauge.
- J.** START OIL BURNER
1. Open vent fitting on fuel pump.
  2. TURN 'ON' BURNER service switch and allow burner to run until oil flows from vent fitting in a

**Table 4: Beckett AFG, AF, & SF Burners**

Boiler Model	Firing Rate (GPH)	Hago Nozzle	Air		Settings	
			Shutter	Band	Head (stop screw)	Pump Pressure
RSA85	.85	.75 x 70B	10	0	N/A	140
RSA110	1.10	.90 x 80B	8	0	N/A	140
RSA125	1.25	1.0 x 80B	7	0	N/A	140
RSA135	1.35	1.10 x 80B	9	0	N/A	140
RSA170	1.70	1.65 80 A	7	0	N/A	100
RSA195	1.95	2.00 80 B	7	0	N/A	100
RSA240	2.40	2.50 80 B	7	0	N/A	100
RSA285	2.85	3.00 80 B	7	0	N/A	100

**Table 4A: Becket AFG Burner**

Boiler Model	Firing Rate (GPH)	Hago Nozzle	Air		Settings	
			Shutter	Band	Head (stop screw)	Pump Pressure
RSAH85	.75	.65 x 80B	6	0	N/A	140
RSAH110	1.0	.85 x 80B	7	0	N/A	140
RSAH125	1.1	.90 x 80B	7	0	N/A	140
RSAH135	1.25	1.0 x 80B	9	0	N/A	140

SOLID stream without air bubbles for approximately 10 seconds.

- Close vent fitting and burner flame should start immediately.
- If the burner does not start immediately, check the manual overload switch on the motor, if so equipped, and the safety switch on the burner primary control.

#### K. ADJUST OIL PRESSURE

- Locate oil pressure adjusting screw and turn screw until Pressure Gauge reads the correct pump pressure required for the specific boiler. Refer to table 4 & 4A.
- DO NOT REMOVE PRESSURE GAUGE until later.

#### L. OTHER ADJUSTMENTS

- ADJUST THE AIR BAND AND/OR AIR SHUTTER.

Beckett Burners:

- Adjust air supply by loosening lock screws and moving the air shutter and if necessary the air band. Refer to Table 4 and 4A preliminary settings.
- ADJUST DRAFT REGULATOR for a draft of -.02" (water gauge) over the fire after chimney has reached operating temperature and while burner is running.
  - READJUST AIR BANDS on burner for a light orange colored flame while draft over the fire is -.02" w.c. Use a smoke test and adjust air for minimum smoke (not to exceed #1) with a minimum of excess air. Make final check using suitable

(Non-Burnham Drawing  
Copy from other Manual)

**Figure 23: Electrode / Head Setting**

instrumentation to obtain a  $\text{CO}_2$  of 11.5 to 12.5% with draft of  $-.02''$  w.c. in fire box. These settings will assure a safe and efficient operating condition. If the flame appears stringy instead of a solid flame, try another nozzle of the same type. Flame should be solid and compact. After all adjustments have been made, recheck for a draft of  $-.02''$  w.c. over the fire.

4. TURN "OFF" BURNER and remove pressure gauge. Install gauge port plug and tighten. Start burner again.

**M. FLAME FAILURE**

The RSA boiler controls operate the burner automatically. If for unknown reasons the burner ceases to fire and the rest button on the primary control has tripped, the burner has experienced ignition failure. Before pressing the rest button, call your serviceman immediately.

**N. CHECK FOR CLEAN CUT OFF OF BURNER**

1. AIR IN THE OIL LINE between fuel unit and nozzle will compress when burner is on and will expand when burner stops, causing oil to squirt from nozzle at low pressure as burner slows down and causing nozzle to drip after burner stops. Usually cycling the burner operation about 5 to 10 times will rid oil line of this air.

2. IF NOZZLE CONTINUES TO DRIP, repeat step N.1. If this does not stop the dripping, remove cut off valve and seat, and wipe both with a clean cloth until clean. Then replace and readjust oil pressure. If dripping or after burn persist replace fuel pump.

**O. HINTS ON COMBUSTION**

- a. NOZZLES— Although the nozzle is a relatively inexpensive device, its function is critical to the successful operation of the oil burner. The selection of the nozzle supplied with the RSA boiler is the result of extensive testing to obtain the best flame shape and efficient combustion. Other brands of the same spray angle and spray pattern may be used but may not perform at the expected level of  $\text{CO}_2$  and smoke. Nozzles are delicate and should be protected from dirt and abuse. Nozzles are mass produced and can vary from sample to sample. For all of those reasons a spare nozzle is a desirable item for a serviceman to carry.
- b. FLAME SHAPE — Looking into the combustion chamber through the flame plug hole, the flame should appear straight with no sparklers rolling up toward the top of the chamber. If the flame drags to the right or left, sends sparklers upward or makes wet spots on the combustion chamber, the nozzle should be replaced. If the condition persists look for fuel leaks, air leaks, water or dirt in the fuel as described below.
- c. FUEL LEAKS— Any fuel leak between the pump and the nozzle will be detrimental to good combustion results. Look for wet surfaces in the air tube, under the ignitor, and around the air inlet. Any such leaks should be repaired as they may cause erratic burning of the fuel and in the



extreme case may become a fire hazard.

- d. AIR LEAKS— Any such leaks should be repaired, as they may cause erratic burning of the fuel and in extreme cases may become a fire hazard.

There may be many possible causes of leaks in oil lines such as:

- i. Fitting leaks due to misflared tubing or damaged fitting.
- ii. Fuel line leak due to crushed or bent tubing.
- iii. Filter connection leaks.
- iv. Tank connection leaks.

The following actions can eliminate air leaks:

- i. Bleed pump as detailed in System Start-Up Section of this manual.
  - ii. Replace flare fittings.
  - iii. Replace oil supply line.
  - iv. Repair oil filter leaks
  - v. Replace or repair tank fittings.
- e. GASKET LEAKS— If 11.5% to 12.5% CO<sub>2</sub> with a #1 smoke cannot be obtained in stack, look for air leaks around the canopy seal. Such air leaks will cause a lower CO<sub>2</sub> reading in the stack. The smaller the firing rate the greater effect an air leak can have on CO<sub>2</sub> readings.
  - f. DIRT— A fuel filter is a good investment. Accidental accumulation of dirt in the fuel system can clog the nozzle strainer and produce a poor spray pattern from the nozzle.
  - g. WATER— Water in the fuel, in large amounts, will stall the fuel pump. Water in the fuel pump, in smaller amounts, will cause excessive wear on the pump, but more importantly water does not burn. It chills the flame, causes smoke, and allows unburned fuel to pass through the combustion chamber and clog the flueways of the boiler.
  - h. COLD OIL— If the oil temperature approaching the fuel pump is 40°F or lower, poor combustion or delayed ignition may result. Cold

oil is harder to atomize at the nozzle. Thus, the spray droplets get larger and the flame shape gets longer. An outside fuel tank that is above grade or has fuel lines buried in the ground above the frost line is a good candidate for cold oil. The best solution is to place the tank and oil lines in the ground below the frost line.

#### i. HIGH ALTITUDE INSTALLATIONS

Typically, the rule to use for high altitudes is to increase the air supply by 4% per each 1000 ft. above 2000 ft. altitude from sea level. This means that the air setting will have to be higher than the calibration marks in proportion to the altitude. Use instruments and set for 11.5 to 12.5% CO<sub>2</sub>.

- j. START-UP NOISE — Late ignition is the cause of start-up noises. If it occurs recheck for electrode settings, flame shape, air or water in the fuel lines.

- k. SHUT DOWN NOISE — If the flame runs out of air before it runs out of fuel, an after burn with noise may occur. That may be the result of a faulty cut-off valve in the fuel pump, or it may be air trapped in the nozzle line. It may take several firing cycles for that air to be fully vented through the nozzle. Water in the fuel or poor flame shape can also cause shut down noises.

### P. TEST CONTROLS

1. CHECK THERMOSTAT OPERATION. Raise and lower thermostat setting as required to start and stop burner.
2. VERIFY PRIMARY CONTROL SAFETY FEATURES using procedures outlined in Instructions furnished with control (See back of Control Cover) or Instructions as follows:

## NOTICE

**CHECK TEST PROCEDURE. A very good test for isolating fuel side problems is to disconnect the fuel system and with a 24" length of tubing, fire out of an auxiliary five gallon pail of clean, fresh, warm #2 oil from another source. If the burner runs successfully when drawing out of the auxiliary pail then the problem is isolated to the fuel or fuel lines being used on the jobsite.**

- a. **Simulate flame failure:**
    - Follow the starting procedure to turn on the burner.
    - Close the hand valve in the oil supply line.
    - Safety switch should lock out in approximately 15 seconds. Ignition should stop and oil valve should close. Blower will stop after postpurge period.
    - Push red reset button to reset safety switch.
  - b. **Simulate ignition failure:**
    - Follow the starting procedure to turn on the burner, but do not open the oil supply hand valve.
    - Safety switch should lock out in approximately 15 seconds. Ignition and motor should stop and oil valve should close.
    - Push red reset button to reset safety switch.
  - c. **Simulate power failure:**
    - Follow the starting procedure to turn on the burner.
    - With the burner running, turn off the power to the system by tripping the circuit breaker or removing the fuse.
    - Burner should stop.
    - Restore power. Burner should start.
3. **VERIFY HIGH LIMIT OPERATION.**
- a. Adjust thermostat to highest setting.
  - b. Observe temperature gauge. When temperature is indicated, adjust limit to setting below observed temperature. Burner should stop.
  - c. Adjust limit to setting above observed temperature. Burner should start.
  - d. Adjust thermostat to lowest setting. Adjust limit to desired setting.

4. **CHECK LOW WATER CUTOFF** (if so equipped).
  - a. Adjust thermostat to highest setting.
  - b. With boiler operating, open drain valve and slowly drain boiler.
  - c. Burner should stop when water level drops below low water cutoff probe. Verify limit, thermostat or other controls have not shut off boiler.
  - d. Adjust thermostat to lowest setting. Refill boiler.

**Q.** Boiler is now ready to be put into service.

A leaky system will increase the volume of make-up water supplied to the boiler which can significantly shorten the life of the boiler. Entrained in make-up water are dissolved minerals and oxygen. When the fresh, cool make-up water is heated in the boiler the minerals fall out as sediment and the oxygen escapes as a gas. Both can result in reduced boiler life. The accumulation of sediment can eventually isolate the water from contacting the steel. When this happens the steel in that area gets extremely hot and eventually cracks. The presence of free oxygen in the boiler creates a corrosive atmosphere which, if the concentration becomes high enough, can corrode the steel through from the inside. Since neither of these failure types are the result of a manufacturing defect the warranty does not apply. Clearly it is in everyone's best interest to prevent this type of failure. The maintenance of system integrity is the best method to achieve this.

# INSTALLATION INSTRUCTIONS FOR SHIELD REQUIRED FOR COMBUSTIBLE FLOOR

This shield for combustible floors is intended for use **only** with the following Burnham oil-fired boilers:

Use Part Number 6183504 for the following models:

RSA(H)85    RSA(H)110    RSA(H)125    RSA(H)135  
ADDS 4-3/16" TO BOILER HEIGHT

Use Part Number 6183505 for the following models:

RSA170    RSA195    RSA240    RSA285  
ADDS 5-3/8" TO BOILER HEIGHT

- 1) Place shield on combustible floor with "TOP" surface upward and "FRONT" surface directly below the expected position of the oil burner.
- 2) Locate shield such that clearances to combustible walls are as indicated in Figure 24. These dimensions will assure that the boiler jacket will be at least 18" from the side and rear walls and 48" from the front wall, as required by ANSI/NFPA 31.
- 3) Fasten shield to combustible floor to keep shield from shifting position during setting of boiler.
- 4) Set boiler squarely on top of shield such that base plate of boiler rests flat on top surface of shield and does not over-hang shield on any side. Confirm clearance to combustible walls. Refer to Figure 2.
- 5) Do not enclose boiler (including shield) on all four sides. Boiler may be enclosed on any three sides while maintaining minimum clearance shown in Figure 24 for each of those three sides.

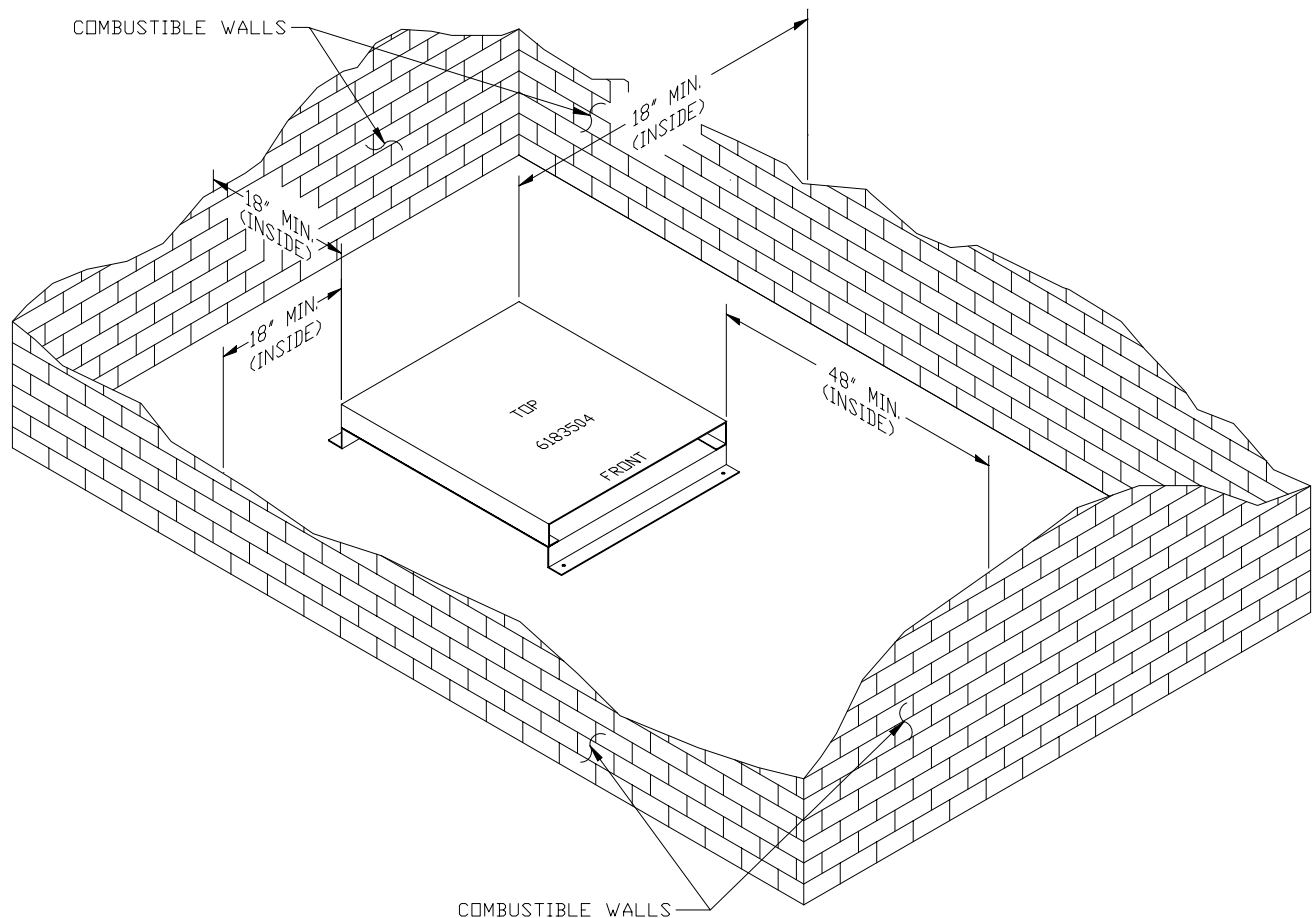

Figure 24

# VIII. Service and Cleaning

## NOTICE

**BURNER SHUTDOWN:** Open Service Switch to turn off burner.

**Manual Oil Supply Valve should be closed and Electric Service to boiler turned off if boiler will not be operated for an extended period of time.**

**A. General.** Inspection service and cleaning should be conducted annually. Turn off electric power and close oil supply valve while conducting service or maintenance.

**B. Firetubes and Combustion Chamber.** (See Figure 25)

### 1. CLEAN THE FIRETUBES

- a. Disconnect electric to burner and remove stack.
- b. For access to the firetubes, pull top jacket panel off. Loosen wing nuts, that hold canopy down. Without taking wing nuts off carriage bolts, disengage bolts from slots on tubesheet. Pull canopy off.
- c. Remove turbulators.
- d. Using a firetube brush clean firetubes. **DO NOT** extend brush past the end of the bottom tubesheet.
- e. Assemble the boiler in reverse order.

Units should be cleaned at least once a year, preferably at the end of each heating season.

It is not necessary to remove burner to clean boiler.

Brush, scrape, or vacuum from **top**.

NOTE: UNITS SHOULD BE CLEANED AT LEAST ONCE A YEAR, PREFERABLY AT THE END OF EACH HEATING SEASON.

IT IS NOT NECESSARY TO REMOVE BURNER TO CLEAN BOILER.

BRUSH, SCRAPE OR VACUUM CLEAN FLUE TUBES CAREFULLY FROM TOP WITHOUT EXTENDING CLEANING TOOLS BEYOND BOTTOM OF FLUE TUBES TO PREVENT DAMAGE TO COMBUSTION CHAMBER.

**CAUTION**

COMBUSTION CHAMBER IS A LIGHTWEIGHT CERAMIC TYPE. **DO NOT** EXTEND CLEANING TOOLS BEYOND BOTTOM OF FLUE TUBES TO PREVENT DAMAGE TO COMBUSTION CHAMBER.

BOILER MODEL	DIMENSION 'X'
RSA-85/110	13.375
RSA-125/135	19.875

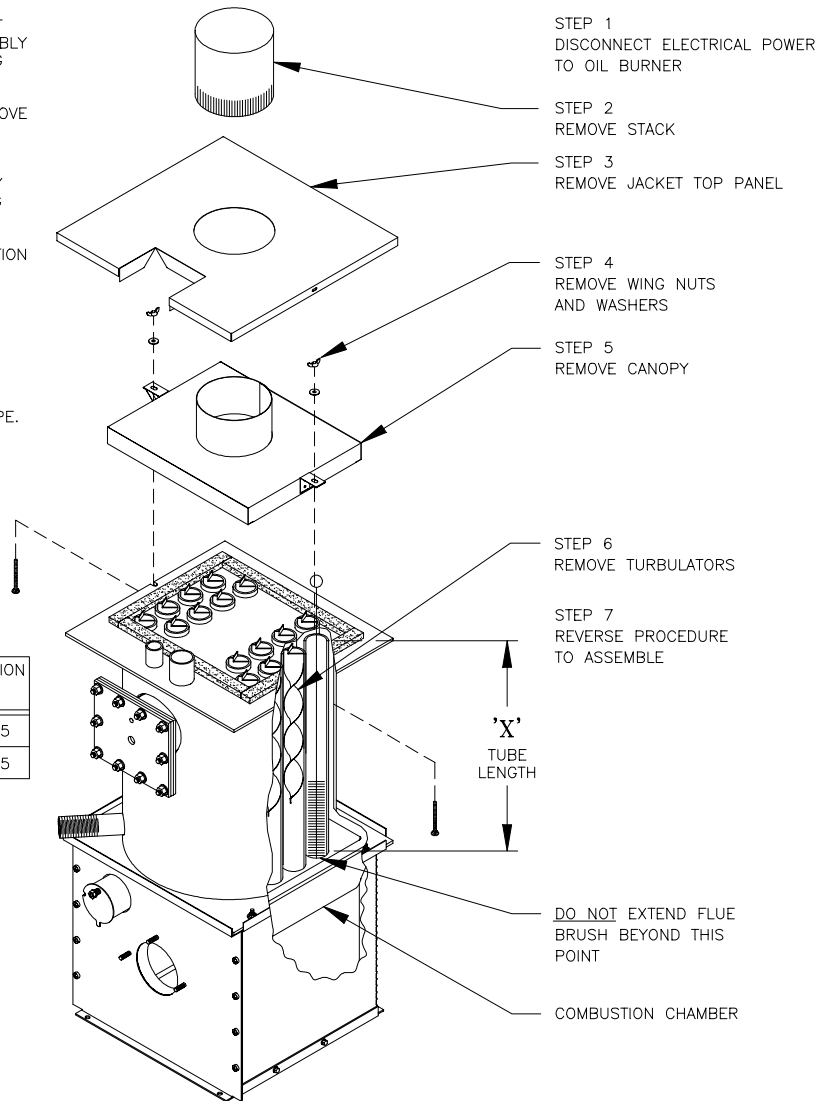

CLEANING INSTRUCTIONS

Figure 25: Cleaning of RSA Boiler

## IX. Repair Parts

All RSA Repair Parts may be obtained through your local Burnham Wholesale distributor. Should you require assistance in locating a Burnham distributor in your area, or have questions regarding the availability of Burnham products or repair parts, please contact your Burnham Regional Sales Office as listed below.

### Burnham Corporation Regional Offices

<p>A. Burnham Corporation - Central &amp; Western Regions  P.O. Box 3079  Lancaster, PA 17604-3079  Phone: (717) 481-8400  FAX: (717) 481-8408</p>	<p>C. Burnham Corporation - Metropolitan Region  P.O. Box 3079  Lancaster, PA 17604-3079  Phone: (717) 481-8400  FAX: (717) 481-8409</p>
<p>B. Burnham Sales Corporation - Northeast Region  19-27 Mystic Avenue  Somerville, MA 02145  Phone: (617) 625-9735  FAX: (617) 625-9736</p>	<p>D. Burnham Corporation - Mid-Atlantic Region  P.O. Box 3079  Lancaster, PA 17604-3079  Phone: (717) 481-8400  FAX: (717) 481-8409</p>

### Contact Regional Office Indicated for your State

Alabama	A	Nebraska	A	Oregon	A		
Alaska	A	Nevada	A	Pennsylvania	D		
Arizona	A	New Hampshire	B	Rhode Island	B		
Arkansas	A	New Jersey <i>Atlantic, Burlington, Camden, Cape May, Cumberland, Gloucester, Mercer, Monmouth, Ocean, Salem Counties All other Counties</i>	D	South Carolina	A		
California	A			South Dakota	A		
Colorado	A			Tennessee	A		
Connecticut	B			Texas	A		
Delaware	D			Utah	A		
Florida	A			Vermont	B		
Georgia	A			Virginia <i>Arlington, Accomack, Clarke, Fairfax, Frederick, Fauquier, Loudoun, Northampton and Prince William Counties All other Counties</i>	D	Washington	A
Hawaii	A					Washington, D.C.	D
Idaho	A					West Virginia	D
Illinois	A					Wisconsin	A
Indiana	A	Wyoming	A				
Iowa	A						
Kansas	A						
Kentucky	A						
Louisiana	A						
Maine	B	North Carolina	A	Oklahoma	A		
Maryland	D	North Dakota	A				
Massachusetts	B	Ohio <i>Athens, Belmont, Gallia, Jefferson, Lawrence, Meigs, Monroe, and Washington Counties All other Counties</i>	D				
Michigan	A						
Minnesota	A						
Mississippi	A						
Missouri	A						
Montana	A					Canada	A

## REPAIR PARTS

NOTE: When ordering parts always give the serial number and model number shown on the boiler. Also provide the name of the part(s) shown below:

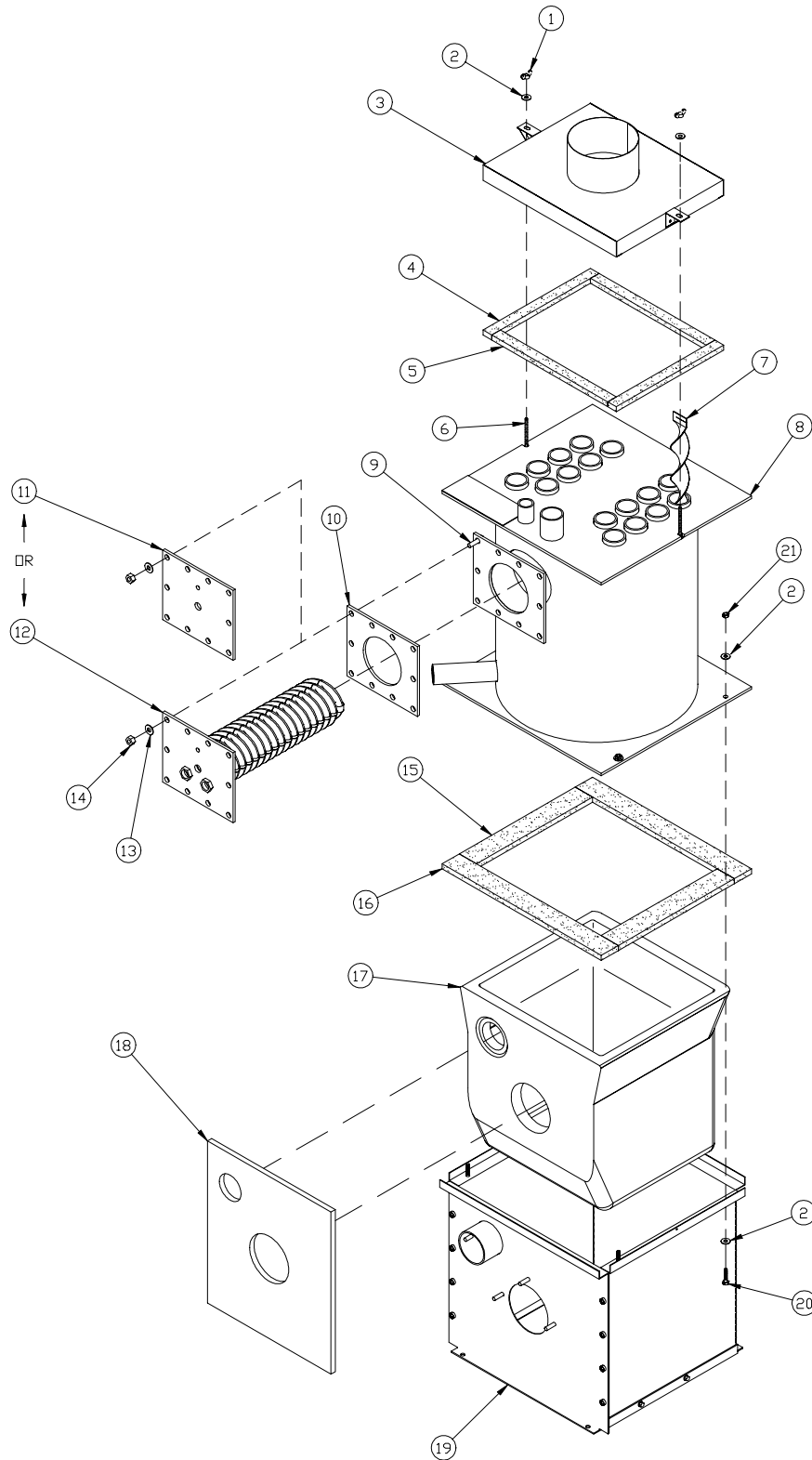

Figure 26: RSA85-135 Bare Boiler Repair Parts

ITEM NO.	QTY.	DESCRIPTION	PART NO.
1	2	Wing Nut, 1/4 - 20	80860910
2	10	Washer, Flat 1/4 (SAE)	80860633
3	1	Canopy Assembly	6113509
4	2	1/2" Thick x 1" x 12-3/8" Cerafelt Strip	9206005
5	2	1/2" Thick x 1" x 13-3/8" Cerafelt Strip	9206005
6	2	Carriage Bolt, 1/4 - 20 x 3" Lg.	80860111
7	<b>'A'</b>	Turbulator	8113501
8	1	Heat Exchanger Assembly	<b>'B'</b>
9	10	SA307B 3/8-16 x 1-1/4" Bolt	80861360
10	1	Tankless Heater Gasket	8206036
11	1	Tapped Heater Cover Plate	7036030
12	1	Tankless Heater Coil, (Standard S350)	6036038
		Tankless Heater Coil, (Optional S375)	6036039
13	10	Washer, Flat (USS), 3/8"	80860600
14	10	Hex Nut, 3/8 - 16, Steel, Plain	80860400
15	2	1/2" Thick x 2" x 13-3/4" Cerafelt Strip	9206003
16	2	1/2" Thick x 2" x 18-1/2" Cerafelt Strip	9206003
17	1	Combustion Chamber	8203006
18	1	Cerablanket	8203512
19	1	Base Assembly	6183508
20	4	Machine Screw, Hex Head, 1/4 - 2 x 1/4"	80860810
21	4	Hex Nut, 1/4 - 20 (Heavy Hex)	80860407

BOILER MODEL	<b>'A'</b>	<b>'B'</b>
RSA85	12	603350112
RSA110	16	603350116
RSA125	12	603350212
RSA135	16	603350216

NOTE: When ordering parts always give the serial number and model number shown on the boiler. Also provide the name of the part(s) shown below:

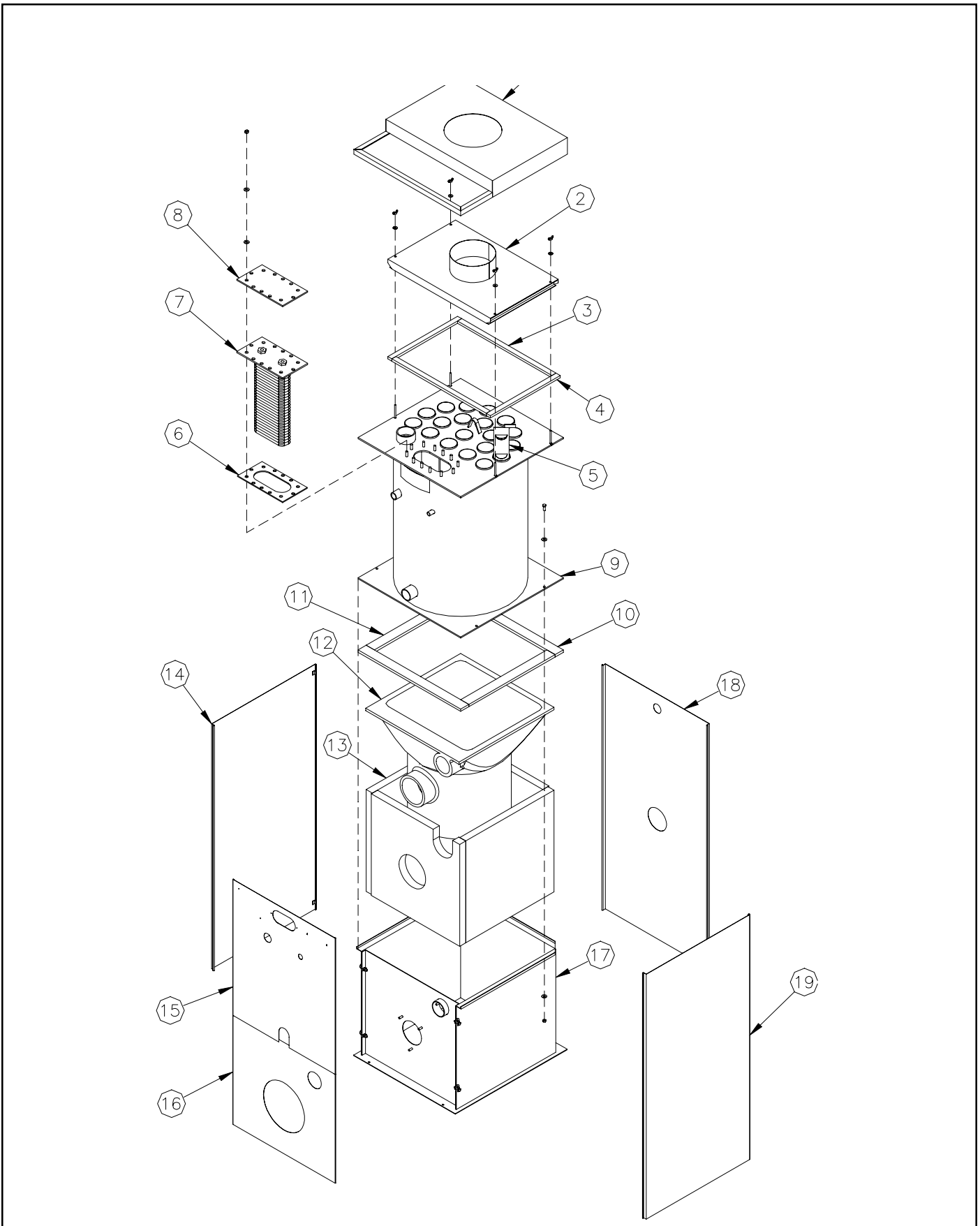

Figure 27: RSA170-285 Boiler Repair Parts



ITEM NO.	DESCRIPTION	PART NO.
1	Jacket Top Panel Assembly	60435022
2	Canopy Assembly	6113510
3	½" Thick x 1" x 23" Cerafelt Strip	9206005
4	½" Thick x 1" x 17" Cerafelt Strip	9206005
5	Turbulator, See 'A' for Quantity	6113504
6	Tankless Heater Gasket	8036025
7	#7524 Tankless Heater Assembly	6036015
	#7530 Tankless Heater Assembly	6036016
8	Tapped Heater Cover Plate	7033501
9	Heat Exchanger Assembly	<b>'B'</b>
10	½ x 2" x 25" Cerafelt Strip	9206003
11	½ x 2" x 21" Cerafelt Strip	9206003
12	Combustion Chamber	8203003
13	Block Insulation Assembly	Supplied with Item #12
14	Jacket Left Side Panel Assembly	60435061
15	Jacket Upper Front Panel Assembly	60435033
16	Jacket Lower Front Panel Assembly	60435042
17	Base Assembly	6186304
18	Jacket Rear Panel Assembly	60435071
19	Jacket Right Side Panel Assembly	60435051

Boiler Model	'A'	'B'
RSA170	10	6306332
RSA195	13	6306329
RSA240	16	6306309
RSA285	19	6306310

ITEM	DESCRIPTION	PART NUMBER
1	Jacket Top Panel	60435086
2	Jacket Wrap-A-Round Panel, RSA85/110	60435087
	Jacket Wrap-A-Round Panel, RSA125/135	60435088
3	Temperature / Pressure Gauge	8056169U
4	Honeywell L8148A1090 Hi-Limit Control	80160449U
	Honeywell L8124C1102 Limit Control	80160406
5	Observation Port Cover / Hardware	8026015
6	Burner Primary Control, R4184D1027	80160473

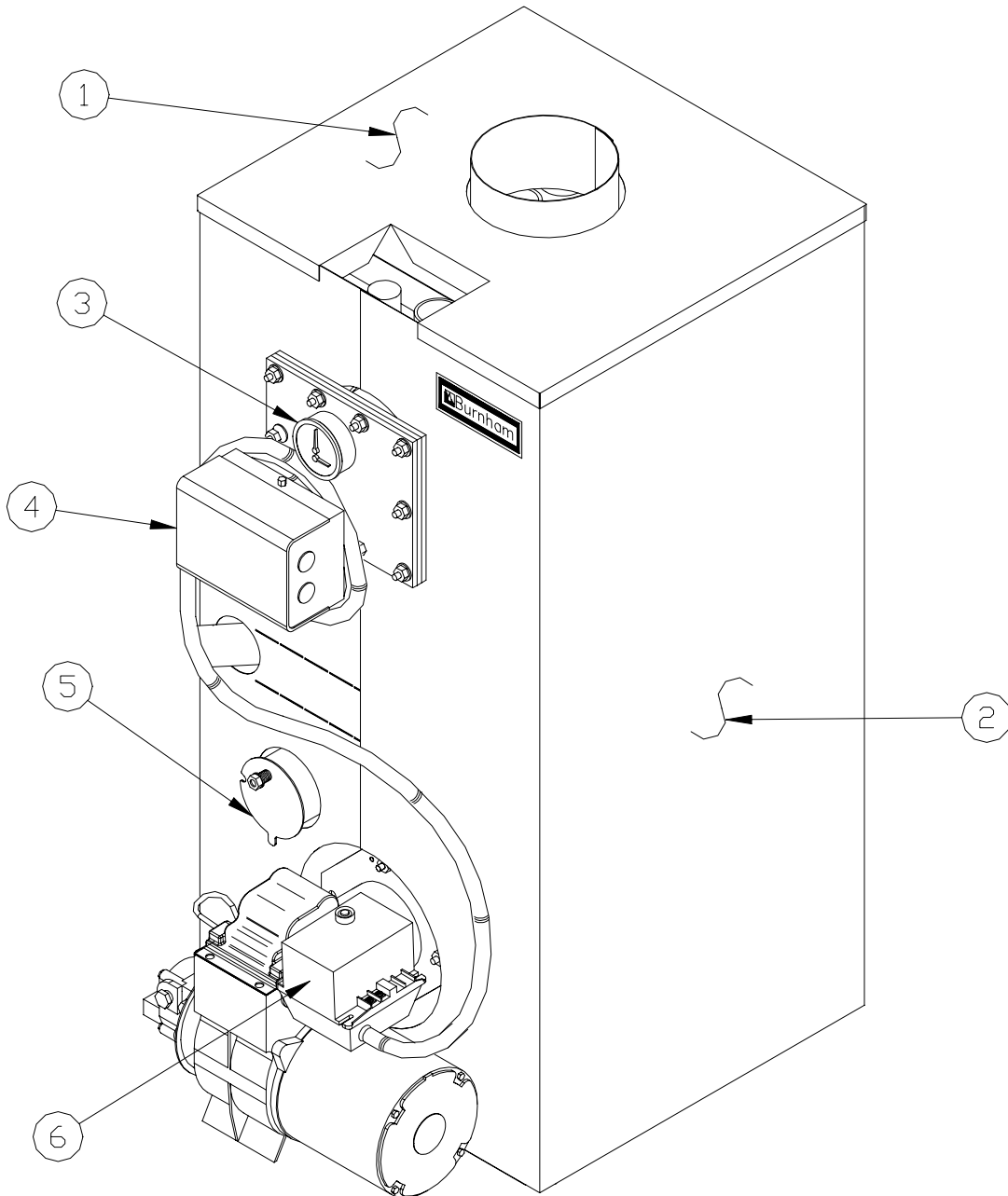

# SERVICE SCHEDULE

DATE

SERVICE PERFORMED

## BECKETT BURNER PARTS LIST FOR RSA SERIES STEEL BOILERS

FOR REPLACEMENT OIL BURNER PARTS, CONTACT YOUR WHOLESALER OR THE BURNER MANUFACTURER:

R. W. BECKETT CORP.  
38251 CENTER RIDGE RD.  
P. O. BOX 1289  
ELYRIA, OHIO 44036  
1-800-645-2876

NOTE: When ordering parts always give the serial and model numbers shown on the boiler and burner. Also, provide the name of the part(s) and part(s) number as listed below.

Boiler Model	RSA85	RSA110	RSA125	RSA135
Burner Model	AFG	AFG	AFG	AFG
Air Tube Combination	AF60BN	AF60XN	AF60J2	AF60JZSS
Spec. No.	BCB6201	BCB6202	BCB6203	BCB6204
1) Air Band	3492BKA	3492BKA	3492BKA	3492BKA
Air Band Nut	4150	4150	4150	4150
Air Band Screw	4198	4198	4198	4198
2) Air Shutter	3709BK	3709BK	3709BK	3709BK
Air Shutter Screw	4198	4198	4198	4198
6) Blower	2999	2999	2999	2999
7) Bulkhead Fitting	3488	3488	3488	3488
8) Bulkhead Fitting Locknut	3666	3666	3666	3666
9) Connector Tube Assembly	5636	5636	5636	5636
10) Coupling	2454	2454	2454	2454
11) Electrode Clamp	149	149	149	149
Electrode Clamp Screw	4219	4219	4219	4219
12) Electrode Insulator Assembly	EA21502	EA21502	EA21502	EA21502
15) Spider Spacer Assembly	5653	5653	5653	5653
16) Escutcheon Plate	3493	3493	3493	3493
18) Flange and Air Tube Assembly	3146812	3146812	3146812	3146812
Gasket	31498	31498	31498	31498
19) Head	360003	360003	360006	360006
Head Screws	4221	4221	4221	4221
Hole Plug	2139	2139	2139	2139
20) Housing Assembly w/Inlet Bell	5624	5624	5624	5624
21) Motor	2456	2456	2456	2456
22) Nozzle Adapter	213	213	213	213
23) Nozzle Line Electrode Assembly	NC6058	NC6058	NC6058	NC6048
25) Pump	2460	2460	2460	2460
27) Static Plate	31646	3383P	31646	31646
28) Ignitor	7440	7440	7440	7440
29) Ignitor Hinge Screw	4217	4217	4217	4217
30) Ignitor Holding Screw	4198	4198	4198	4198
31) Ignitor Gasket Kit	51304	51304	51304	51304
32) Wire Guard	3345	3345	3345	3345
33) Baffle	3708	N/A	N/A	N/A

# Ordering Information for Quality Replacement Parts

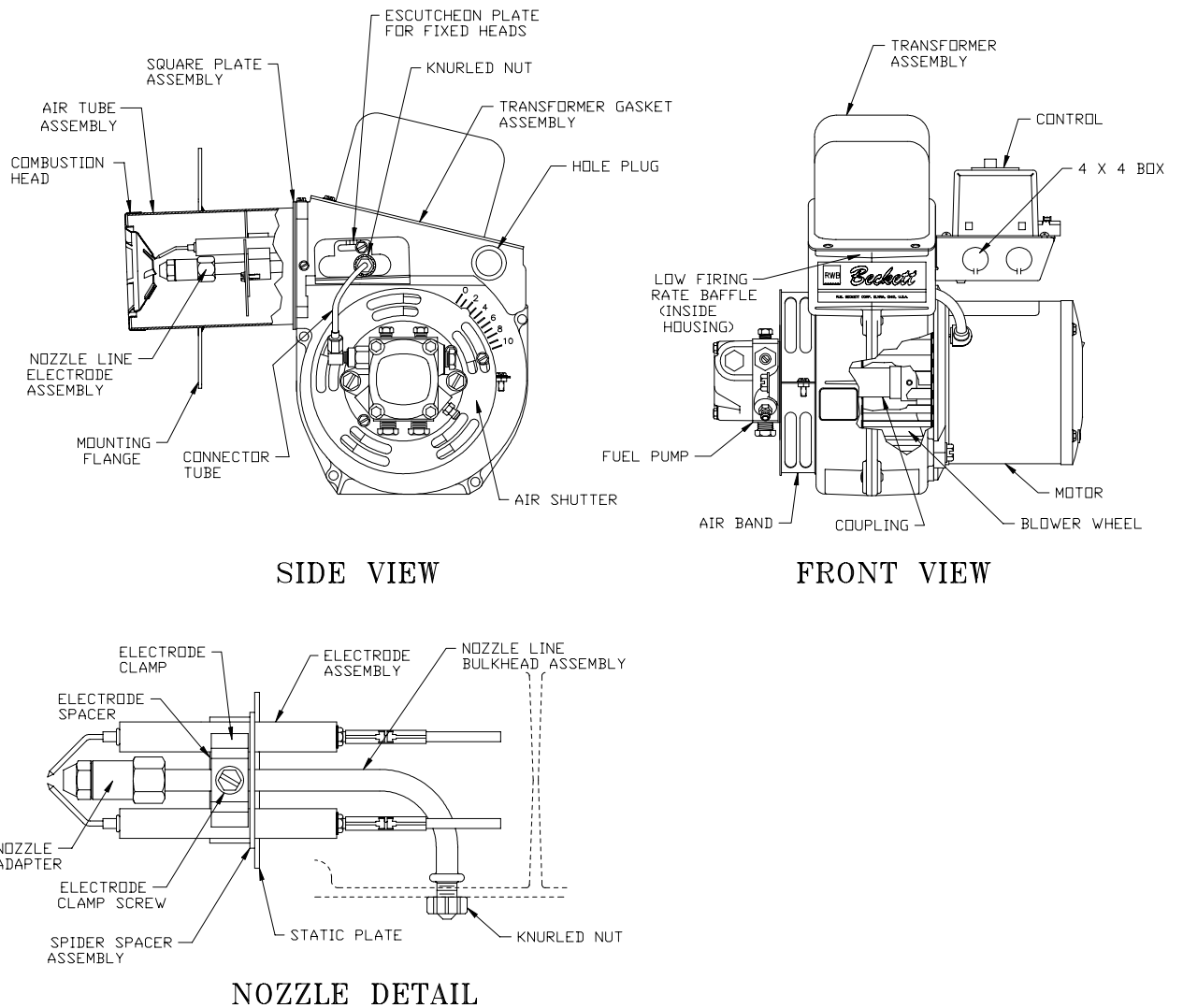

**Figure 29: BECKETT AFG MODEL BURNER**

## BECKETT BURNER PARTS LIST FOR RSA SERIES STEEL BOILERS

FOR REPLACEMENT OIL BURNER PARTS, CONTACT YOUR WHOLESALER OR THE BURNER MANUFACTURER:

R. W. BECKETT CORP.  
38251 CENTER RIDGE RD.  
P. O. BOX 1289  
ELYRIA, OHIO 44036  
1-800-645-2876

Boiler Model	RSA170	RSA195	RSA240/285
Burner Model	AF	AF	AF
Air Tube Combination	AF60XO	AF60XP	SF60FY
Spec. No.	647104	647106	647201
1) Air Band	3492	3492	3217
Air Band Nut	4150	4150	460
Air Band Screw	4198	4198	4219
2) Air Shutter	3494	3494	3215
Air Shutter Screw	4198	4198	493
6) Blower	2459	2459	2288
7) Bulkhead Fitting	3488	3488	3488
8) Bulkhead Fitting Locknut	3666	3666	3666
9) Connector Tube Assembly	5636	5636	5636
10) Coupling	2454	2454	2433
11) Electrode Clamp	149	149	149
Electrode Clamp Screw	4219	4219	4219
12) Electrode Insulator Assembly	EA21502	EA21502	E21502
15) Spider Spacer Assembly	5653	5653	5653
16) Escutcheon Plate	3493	3493	3493
18) Flange and Air Tube Assembly	58115	58115	58115
Gasket	3616	3616	3616
19) Head	360012	360022	5434
Head Screws	4221	4221	4221
Hole Plug	2139	2139	2139
20) Housing Assembly w/Inlet Bell	5624	5624	53485
21) Motor	2456	2456	2364
22) Nozzle Adapter	213	213	213
23) Nozzle Line Electrode Assembly	NC6048	NC6058	NC6048
25) Pump	2460	2460	2460
27) Static Plate	3383	3383	3383
28) Ignitor	7440	7440	7440
29) Ignitor Hinge Screw	4217	4217	4217
30) Ignitor Holding Screw	4198	4198	4198
31) Ignitor Gasket Kit	51304	51304	51304
32) Wire Guard	3345	3345	3345

# Ordering Information for Quality Replacement Parts

---

**Figure 30: BECKETT AF and SF MODEL BURNERS**

