

## Table of Contents

4	Building HVAC Requirements	1
4.1	Overview	1
4.1.1	Introduction and Organization	1
4.1.2	What's New for the 2019 Energy Standards	1
4.1.3	California Appliance Standards and Equipment Certification	3
4.2	Heating Equipment	4
4.2.1	Mandatory Measures for Heating Equipment	4
4.2.2	Prescriptive Requirements for Heating Equipment	13
4.2.3	Performance Compliance Options for Heating Equipment	13
4.3	Cooling Equipment	14
4.3.1	Mandatory Measures for Cooling Equipment	14
4.3.2	Prescriptive Requirements for Cooling Equipment	22
4.3.3	Performance Compliance Options for Cooling Equipment	24
4.4	Air Distribution System Ducts, Plenums, Fans, and Filters	26
4.4.1	Mandatory Measures for Air Distribution System Ducts, Plenums, Fans, and Filters	27
4.4.2	Prescriptive Requirements for Air Distribution System Ducts, Plenums, and Fans	53
4.4.3	Compliance Options for Air Distribution System Ducts, Plenums, and Fans	59
4.4.4	Duct Installation Standards	63
4.5	Controls	69
4.5.1	Thermostats	69
4.5.2	Zonal Control for Compliance Credit	70
4.6	Indoor Air Quality and Mechanical Ventilation	73
4.6.1	Compliance and Enforcement	76
4.6.2	Typical Solutions for Single-Family Dwelling Unit Ventilation	79
4.6.3	Typical Solutions for Multifamily Dwelling Unit Ventilation	85
4.6.4	Dwelling Unit Ventilation Airflow Measurement	86
4.6.5	Dwelling Unit Ventilation Rate (Section 4 of ASHRAE 62.2)	87
4.6.6	Dwelling Unit Mechanical Ventilation Energy Consumption	94
4.6.7	Local Exhaust (Section 5 of ASHRAE 62.2)	96
4.6.8	Other Requirements (Section 6 of ASHRAE 62.2)	101

---

4.6.9	Air-Moving Equipment (Section 7 of ASHRAE 62.2)	110
4.7	Alternative Systems	116
4.7.1	Hydronic Heating Systems	116
4.7.2	Radiant Floor System	120
4.7.3	Evaporative Cooling	124
4.7.4	Ground-Source Heat Pumps	126
4.7.5	Solar Space Heating	126
4.7.6	Wood Space Heating	126
4.7.7	Gas Appliances	129
4.7.8	Evaporatively Cooled Condensers	129
4.7.9	Nonducted Systems	129
4.7.10	Ventilation Cooling	129
4.8	Refrigerant Charge	139
4.8.1	Refrigerant Charge Verification	139
4.9	Compliance and Enforcement	147
4.9.1	Design-Phase Documentation	147
4.9.2	Construction-Phase Documentation	148
4.9.3	Field Verification and/or Diagnostic Testing	149

---

## 4 Building HVAC Requirements

---

### 4.1 Overview

#### 4.1.1 Introduction and Organization

This chapter addresses the requirements for heating, ventilating, and air-conditioning (HVAC) systems. The requirements are a source of information for mechanical system designers and installers, as well as energy consultants, Home Energy Rating System (HERS) Raters, and enforcement personnel.

Each section in this chapter outlines the mandatory measures and, when applicable, the prescriptive requirements or compliance options. These prescriptive requirements vary by climate zone and building type. If the building design does not achieve the minimum prescriptive requirements, consider using the performance compliance option that allows for making up the deficiencies with other HVAC or building features.

Each section of this chapter includes mandatory measures, prescriptive requirements, and performance options. The chapter is organized under the following sections:

1. **Section 4.2** – Heating Equipment.
2. **Section 4.3** – Cooling Equipment.
3. **Section 4.4** – Air Distribution System Ducts, Plenums, and Fans.
4. **Section 4.5** – Controls.
5. **Section 4.6** – Indoor Air Quality and Mechanical Ventilation.
6. **Section 4.7** – Alternative Systems.
7. **Section 4.8** – Compliance and Enforcement.
8. **Section 4.9** – Refrigerant Charge.

Chapter 9 covers the heating and cooling requirements for additions to existing dwellings and for alterations to existing heating and cooling systems.

#### 4.1.2 What's New for the 2019 Energy Standards

The following is an overview of the new HVAC measures for the *2019 Building Energy Efficiency Standards* (Energy Standards), including new compliance options that provide greater flexibility in complying with the Energy Standards when using the performance method.

**4.1.2.1 Mandatory Features and Devices - §150.0**

1. Fan efficacy requirements are 0.45 watts/cubic feet per minute (CFM) or less for gas furnace air-handling units or 0.58 watts/CFM or less for air-handling units that are not gas furnaces. This requirement applies to single zone and zonally controlled forced air systems (§150.0(m)13B and 13C).
2. Small-duct, high-velocity forced-air systems must meet a fan efficacy of 0.62 Watts/CFM or less and an airflow requirement of 250 CFM/ton or greater (§150.0(m)13D).
3. Two exceptions allow portions of a duct system to be uninsulated if specific conditions are met, as explained in Section 4.4.1 (Exceptions 1 and 2 to §150.0(m)1B).
4. Exceptions to requirements for a porous inner core flex duct is allowable if it has a nonporous layer or air barrier between the inner core and outer vapor barrier (§150.0(m)10).
5. There are changes to the mandatory air filtration requirements for space-conditioning systems with 10 feet or more of duct attached. The requirements affect the pressure drop and labeling of the filtration devices (§150.0(m)12).
6. Air filtration is now required on supply and balanced mechanical ventilation systems.
7. With the adoption of ASHRAE Standard 62.2-2016, higher mechanical ventilation rates will be required for single family units which vary by climate zone.

**4.1.2.2 Prescriptive and Performance Compliance Approaches – §150.1**

1. The refrigerant charge requirement in the prescriptive tables applies to all air conditioners and heat pumps, including small duct high, velocity systems (§150.1(c)7A).
2. Central fan-integrated ventilation systems used in prescriptive compliance must meet the mandatory fan efficacy requirement of 0.45 watts/CFM or less for gas furnace air-handling units or 0.58 watts/CFM or less for air-handling units that are not gas furnaces (§150.1(c)10).
3. Heat pumps used in performance compliance may require HERS verification of the heating seasonal performance factor (HSPF) and heating capacity as explained in Section 4.2.3 (§150.1(b)3).
4. Whole house fans used in performance compliance may require HERS verification of the airflow rate and fan efficacy as explained in Section 4.3.3 (§150.1(b)3).
5. Central fan ventilation cooling systems used in performance compliance may require HERS verification of the system airflow rate and fan efficacy at ventilation speed, as explained in Section 4.3.3 (§150.1(b)3).

#### 4.1.2.3 Additions and Alterations – §150.2

The Energy Standards requirements for altered or new HVAC systems in existing homes are summarized and discussed in Chapter 9.

#### 4.1.3 California Appliance Standards and Equipment Certification

##### §110.0 and §110.1

Most heating and cooling equipment installed in new California homes is regulated by the National Appliance Efficiency Conservation Act (NAECA) and/or the California *Appliance Efficiency Regulations (Title 20)*. Both the federal and state appliance standards apply to the manufacturing and sale of new equipment, whether for new construction, replacements, or repairs. The *Appliance Efficiency Regulations* are enforced at the point of sale (except central split-system air conditioners and central single package air conditioners, see Table 4-6), while the Energy Standards explained in this compliance manual are enforced by local enforcement agencies.

The equipment listed below is covered by the *Appliance Efficiency Regulations*. The manufacturer must certify that the equipment complies with the current *Appliance Efficiency Regulations* at the time of manufacture.

Appliances covered by the *Appliance Efficiency Regulations* include:

1. Room air conditioners
2. Room air-conditioning heat pumps
3. Central air conditioners with a cooling capacity of less than 135,000 British thermal units per hour (Btu/hr)
4. Central air conditioning heat pumps
5. Gas-fired central furnaces
6. Gas-fired boilers
7. Gas-fired furnaces
8. Gas-fired floor furnaces
9. Gas-fired room heaters
10. Gas-fired duct furnaces
11. Gas-fired unit heaters

The *Appliance Efficiency Regulations* do not require certification for:

1. Electric resistance space heaters.
2. Oil-fired wall furnaces, floor furnaces, and room heaters. (Some are voluntarily listed with certified gas-fired furnaces.)

Equipment that does not meet the federal appliance efficiency standards may not be sold in California. Any equipment covered by the *Appliance Efficiency Regulations* and sold in California must have the date of manufacture permanently displayed in an accessible place on that equipment. This date is frequently included as part of the serial number.

Generally, equipment manufactured before the effective date of a new standard may be sold and installed in California indefinitely as long as the performance approach demonstrates energy compliance of the building using the lower efficiency of the relevant appliances. An exception is central split-system air conditioners and central single package air conditioners *installed* in California. The U.S. Department of Energy (DOE) requires compliance with the minimum efficiencies specified in Table 4-6 at the time of installation.

The compliance and enforcement processes should ensure that all installed HVAC equipment regulated by the *Appliance Efficiency Regulations* is certified by the California Energy Commission.

#### 4.1.3.1 Plan Review (Compliance)

During the plan review, the builder is responsible for demonstrating compliance with the *Appliance Efficiency Regulations* by providing the efficiency of the HVAC equipment that is to be installed. Typically, the builder does not identify the exact make or model at this point of the process. The plans examiner is responsible for verifying that the specified equipment efficiency complies with the *Appliance Efficiency Regulations*.

#### 4.1.3.2 Field Inspection (Enforcement)

It is the field inspector's responsibility to visually verify that the product information on the installed HVAC equipment matches the efficiency approved by the plans examiner. To simplify the inspection, the field inspector may reference the CF2R-MCH-01-H form submitted by the builder/installing contractor.

---

## 4.2 Heating Equipment

This section addresses the requirements for heating equipment, including furnaces, boilers, heat pumps, and electric resistance equipment.

### 4.2.1 Mandatory Measures for Heating Equipment

#### 4.2.1.1 Equipment Efficiency

§110.1 and §110.2(a)

The efficiency of most heating equipment is regulated by the National Appliance Energy Conservation Act of 1987 (NAECA, the federal appliance standard) and the California Appliance Efficiency Regulations. These regulations are not contained in the Energy Standards but are published separately. These regulations are referenced in §110.1. The Appliance Efficiency Regulations include definitions for all types of equipment and are regularly updated.

Note: The Appliance Efficiency Regulations that are in effect when the building permit is applied for will determine the minimum efficiency of the appliances identified in the compliance documentation.

The energy efficiency of other equipment is regulated by §110.2(a). Also, see the *Nonresidential Compliance Manual* for more information on larger equipment.

**A. Gas and Oil-Fired Furnaces**

The Appliance Efficiency Regulations (Title 20) require gas- and oil-fired central furnaces with outputs less than 225,000 Btu/hr to be rated according to the associated annual fuel utilization efficiency (AFUE). Gas- and oil-fired central furnaces with outputs greater than or equal to 225,000 Btu/hr are rated according to the respective thermal (or steady-state) efficiency. Refer to Table 4-1 for the applicable efficiency requirements.

**Table 4-1: Minimum Efficiency for Gas- and Oil-Fired Central Furnaces**

Appliance	Rated Input (Btu/hr)	Minimum Efficiency (%) AFUE	Minimum Efficiency (%) Thermal Efficiency
Weatherized gas central furnaces with single phase electrical supply	< 225,000	81	—
Non-weatherized gas central furnaces with single phase electrical supply	< 225,000	80	—
Weatherized oil central furnaces with single phase electrical supply	< 225,000	78	—
Non-weatherized oil central furnaces with single phase electrical supply	< 225,000	83	—
Gas central furnaces	≥ 225,000	—	80
Oil central furnaces	≥ 225,000	—	81

Source: *California Appliance Efficiency Regulations Title-20* - Table E-5 and E-6

Noncentral gas furnaces and space heaters manufactured on or after April 16, 2013, shall be certified to have AFUE values greater than or equal to those listed in Table 4-2.

**Table 4-2: Minimum Heating Efficiency for Nonducted, Noncentral, Gas-Fired Heating Equipment**

Type	Capacity	AFUE
Wall Furnace (fan type)	≤ 42,000 Btu/hr	75%
Wall Furnace (fan type)	> 42,000 Btu/hr	76%
Wall Furnace (gravity type)	≤ 27,000 Btu/hr	65%
Wall Furnace (gravity type)	> 27,000 to ≤ 46,000 Btu/hr	66%
Wall Furnace (gravity type)	> 46,000 Btu/hr	67%
Floor Furnace	≤ 37,000 Btu/hr	57%
Floor Furnace	> 37,000 Btu/hr	58%
Room Heater	≤ 20,000 Btu/hr	61%
Room Heater	> 20,000 to ≤ 27,000 Btu/hr	66%
Room Heater	> 27,000 to ≤ 46,000 Btu/hr	67%
Room Heater	> 46,000 Btu/hr	68%

Source: *California Appliance Efficiency Regulations Title 20 - Table E-2*

### **B. Heat Pumps and Electric Heating**

Heat pumps shall be certified to have a HSPF or coefficient of performance (COP) equal to or better than those listed in Table 4-3.

There are no minimum appliance efficiency standards for electric-resistance or electric-radiant heating systems.

### **C. Gas- and Oil-Fired Central Boilers and Electric Boilers**

Gas- and oil-fired central boilers shall be certified to have an AFUE or *Combustion Efficiency* equal to or better than those listed in Table 4-4.



**Table 4-3: Minimum Heating Efficiency for Heat Pumps**

<b>Equipment Type</b>	<b>Reference</b>	<b>Configuration/Size</b>	<b>Minimum Heating Efficiency</b>
Packaged terminal heat pumps (heating mode)	Table 110.2 E	Newly constructed or newly conditioned buildings or additions	$3.7 - (0.052 \times \text{Cap}^1/1000) = \text{COP}$
Packaged terminal heat pumps (heating mode)	Table 110.2 E	Replacements	$2.9 - (0.026 \times \text{Cap}^1/1000) = \text{COP}$
Single-phase air source heat pumps (NAECA)	Table C-3	< 65,000 Btu/hr cooling	Packaged 8.0 HSPF Split 8.2 HSPF
Single-phase air source heat pumps (NAECA)	Table C-3	Space constrained < 65,000 Btu/hr cooling capacity	7.4 HSPF
Single-phase air source heat pumps (NAECA)	Table C-3	Small duct, high velocity < 65,000 Btu/hr cooling capacity	7.2 HSPF
Three-phase air source heat pumps	Table C-4	< 65,000 Btu/hr	7.7 HSPF
Three-phase air source heat pumps	Table C-4	≥ 65,000 and <135,000	3.3 COP
Three-phase air source heat pumps	Table C-4	≥ 135,000 and <240,000	3.2 COP
Three-phase air source heat pumps	Table C-4	≥ 240,000 and <760,000	3.2 COP
Water-source heat pumps	Table C-5	≥ 65,000 and < 135,000 Btu/hr	4.2 COP
Water-source heat pumps	Table C-5	≥ 135,000 Btu/hr, < 240,000 Btu/hr	3.9 COP
Single package vertical heat pumps	Table C-5	< 65,000 single-phase	3.0 COP
Single package	Table C-5	< 65,000 3-Phase	3.0 COP

Equipment Type	Reference	Configuration/Size	Minimum Heating Efficiency
vertical heat pumps			
Single package vertical heat pumps	Table C-5	≥ 65,000 and < 135,000	3.0 COP
Single package vertical heat pumps	Table C-5	≥ 135,000 and < 240,000	2.9 COP

1. Cap = Cooling Capacity

Source: *California Appliance Efficiency Regulation Title 20 and Energy Efficiency Standards*

**Table 4-4: Minimum Efficiency for Gas- and Oil-Fired Central Boilers**

Appliance	Rated Input (Btu/hr)	Minimum Efficiency (%)	Minimum Efficiency (%)
Gas steam boilers with single-phase electrical supply	< 300,000	80 <sup>1</sup>	AFUE
Gas hot water boilers with single-phase electrical supply	< 300,000	82 <sup>1,2</sup>	AFUE
Oil steam boilers with single-phase electrical supply	< 300,000	82	AFUE
Oil hot water boilers with single-phase electrical supply	< 300,000	84 <sup>2</sup>	AFUE
Electric steam residential boilers	< 300,000	—	—
Electric hot water residential boilers	< 300,000	—	—
All other boilers with single-phase electrical supply	< 300,000	—	—
Steam boilers; gas-fired, except natural draft;	≥ 300,000	Thermal Efficiency 79	Combustion Efficiency 80
Steam boilers; gas-fired, natural draft	≥ 300,000	77	80
Steam boilers; oil-fired	≥ 300,000	81	83

<sup>1</sup> No constant burning pilot light design standard.

<sup>2</sup> Automatic means for adjusting temperature design standard. Source: *California Appliance Efficiency*

---

Regulations Title 20 Table E-3 and E-4

#### 4.2.1.2 Heating System Controls

§150.0(i), §110.2(b), Exceptions to §110.2(b), §110.2(c), Exception to §110.2(c)

All heating systems, including heat pumps, must be controlled by a central energy management control system (EMCS) or by a setback thermostat. The setback thermostat must be capable of allowing the occupant to program temperature set points for at least four periods within a 24-hour time span.

No setback thermostat control is required for gravity gas wall heaters, floor heaters, room heaters, fireplaces, wood stoves, and noncentral electric heaters.

Any heat pump with supplementary electric resistance heating requires controls with two capabilities to limit the electric resistance heating. The first required capability is to set the cut-on and cut-off temperatures for the heat pump and supplementary electric resistance heating at different levels.

For example, if the heat pump begins heating when the inside temperature reaches 68°F, the electric resistance heating may be set to come on if the temperature goes below 65°F if the heat pump alone could not maintain the set point of 68°F. Also, there must be an “off” mode that automatically shuts off the electric resistance when the inside temperature reaches 68°F.

The second control capability must prevent the supplementary electric resistance heater from operating if the heat pump alone can meet the heating load, except during defrost. There is a limited exception to this second function for “smart thermostats” that provides: intelligent recovery, staging, ramping, or another control mechanism that prevents the unnecessary operation of supplementary electric resistance heating when the heat pump alone can meet the heating load.

To meet the thermostat requirements, a thermostat for a heat pump must be a “smart thermostat” that minimizes the use of supplementary heating during startup and recovery from setbacks.

Note: Room air conditioner heat pumps are not required to comply with the thermostat requirements.

#### 4.2.1.3 Equipment Sizing

§150.0(h)1 and 2

The Energy Standards do not set limits on the sizing of heating equipment, but they do require that heating loads be calculated for new heating systems. Oversized equipment typically operates less efficiently and can create comfort problems due to excessive cycling and improper airflow.

Acceptable load calculation procedures include methods described in the following publications:

1. *The ASHRAE Handbook – Equipment*

2. *The ASHRAE Handbook – Applications*
3. *The ASHRAE Handbook – Fundamentals*
4. *The SMACNA Residential Comfort System Installation Manual*
5. *ACCA Manual J*

The Energy Standards require that the outdoor design conditions for load calculations be selected from Reference Joint Appendix JA2 and that the indoor design temperature for heating load calculations be 68°F.

The outdoor design temperature must be no lower than the “heating winter median of extremes,” as listed in the Reference Joint Appendix JA2.

If the actual city location for a project is not included in Reference Joint Appendix JA2, or if the data given for a particular city do not match the conditions at the actual site as well as that given for another nearby city, consult the local building department for guidance.

The load calculations must be submitted with the compliance documentation when requested by the building department.

The load calculations may be prepared by 1) a mechanical engineer, 2) the mechanical contractor who is installing the equipment or 3) someone who is qualified to do so in the State of California according to Division 3 of the Business and Professions Code.

The Business and Professions Code does not prohibit an unlicensed person from preparing plans, drawings, or specifications for single-family dwelling units of wood-frame construction not more than two stories and basement in height, or for certain buildings containing no more than four dwelling units of wood-frame construction not more than two stories and basement in height. However, licensure is required for apartment or condominium complexes.

#### 4.2.1.4 **Standby Losses and Pilot Lights**

**§110.5 and §110.2(d)**

Fan-type central furnaces may not have a continuously burning pilot light. This requirement does not apply to wall furnaces, floor furnaces, or any gravity-type furnace. Household cooking appliances also must not have a continuously burning pilot light, except for those without an electrical supply voltage connection and in which each pilot consumes less than 150 Btu/hr.

Larger gas-fired and oil-fired forced air furnaces with input ratings equal to or greater than 225,000 Btu/h (which is bigger than a typical residential furnace) must also have an intermittent ignition device (IID) and either power venting or a flue damper.

A vent damper is an acceptable alternative to a flue damper for furnaces where combustion air is drawn from the conditioned space. All furnaces with input ratings equal to or greater than 225,000 Btu/h, including electric furnaces, that are not within

the conditioned space must have jacket losses not exceeding 0.75 percent of the input rating.

#### 4.2.1.5 Pipe Insulation

§150.0(j)2C, §150.0(j)3, §120.3

The piping for heat pumps and for steam and hydronic heating systems shall meet the insulation requirements provided below in Table 4-5 when the insulation is outside conditioned space, it requires protection from damage caused by environmental conditions. The insulation must be rated for outdoor use or covered with a material that can withstand outdoor conditions. Examples of these types of coverings are aluminum, sheet metal, painted canvas, plastic cover, or, if the insulation is cellular foam, a coating that is water-retardant and shields from solar radiation. Moreover, the insulation used for the refrigerant suction line of a heat pump must be Class I or Class II vapor retardant.

Table 4-5: Insulation Requirements for Heating System Piping

<u>Fluid Operatin</u> <u>g</u> <u>Tempera</u> <u>ture</u> <u>Range</u> <u>(°F)</u>	<u>Insulation</u> <u>Conductivity</u>		<u>Nominal Pipe Diameter (in inches)</u>							
	<u>Conducti</u> <u>vity</u> <u>(in</u> <u>Btu·in/h·f</u> <u>t<sup>2</sup>· °F)</u>	<u>Mean</u> <u>Rating</u> <u>Tempera</u> <u>ture (°F)</u>	<u>≤ 1</u>	<u>1 to &lt;1.5</u>	<u>1.5 to &lt;</u> <u>4</u>	<u>4 to &lt; 8</u>	<u>8 and</u> <u>larger</u>			
<b><u>Space-Heating and Service Water-Heating Systems (Steam, Steam Condensate, Refrigerant, Space Heating, Service Hot Water)</u></b>			<b><u>Minimum Pipe Insulation Required (Thickness in inches or R-value)</u></b>							
<u>Above</u> <u>350</u>	<u>0.32-0.34</u>	<u>250</u>	<u>Inches</u>	<u>4.5</u>	<u>5.0</u>	<u>5.0</u>	<u>5.0</u>	<u>5.0</u>		
			<u>R-value</u>	<u>R 37</u>	<u>R 41</u>	<u>R 37</u>	<u>R 27</u>	<u>R 23</u>		
<u>251-350</u>	<u>0.29-0.32</u>	<u>200</u>	<u>Inches</u>	<u>3.0</u>	<u>4.0</u>	<u>4.5</u>	<u>4.5</u>	<u>4.5</u>		
			<u>R-value</u>	<u>R 24</u>	<u>R 34</u>	<u>R 35</u>	<u>R 26</u>	<u>R 22</u>		
<u>201-250</u>	<u>0.27-0.30</u>	<u>150</u>	<u>Inches</u>	<u>2.5</u>	<u>2.5</u>	<u>2.5</u>	<u>3.0</u>	<u>3.0</u>		
			<u>R-value</u>	<u>R 21</u>	<u>R 20</u>	<u>R 17.5</u>	<u>R 17</u>	<u>R 14.5</u>		
<u>141-200</u>	<u>0.25-0.29</u>	<u>125</u>	<u>Inches</u>	<u>1.5</u>	<u>1.5</u>	<u>2.0</u>	<u>2.0</u>	<u>2.0</u>		
			<u>R-value</u>	<u>R 11.5</u>	<u>R 11</u>	<u>R 14</u>	<u>R 11</u>	<u>R 10</u>		
<u>105-140</u>	<u>0.22-0.28</u>	<u>100</u>	<u>Inches</u>	<u>1.0</u>	<u>1.5</u>	<u>1.5</u>	<u>1.5</u>	<u>1.5</u>		
			<u>R-value</u>	<u>R 7.7</u>	<u>R 12.5</u>	<u>R 11</u>	<u>R 9</u>	<u>R 8</u>		
			<b><u>Nominal Pipe Diameter (in inches)</u></b>							
			<b><u>≤ 1</u></b>	<b><u>1 to &lt;1.5</u></b>	<b><u>1.5 to &lt;</u></b> <b><u>4</u></b>	<b><u>4 to &lt; 8</u></b>	<b><u>8 and</u></b> <b><u>larger</u></b>			
<b><u>Space-Cooling Systems (Chilled Water, Refrigerant and Brine)</u></b>			<b><u>Minimum Pipe Insulation Required (Thickness in inches or R-value)<sup>1</sup></u></b>							
<u>40-60</u>	<u>0.21-0.27</u>	<u>75</u>	<u>Inches</u>	<u>Nonr</u> <u>es</u> <u>0.5</u>	<u>Re</u> <u>s</u> <u>0.7</u> <u>5</u>	<u>Nonr</u> <u>es</u> <u>0.5</u>	<u>Re</u> <u>s</u> <u>0.7</u> <u>5</u>	<u>1.0</u>	<u>1.0</u>	<u>1.0</u>
			<u>R-value</u>	<u>Nonr</u> <u>es</u> <u>R 3</u>	<u>Re</u> <u>s</u> <u>R 6</u>	<u>Nonr</u> <u>es</u> <u>R 3</u>	<u>Re</u> <u>s</u> <u>R 5</u>	<u>R 7</u>	<u>R 6</u>	<u>R 5</u>
<u>Below 40</u>	<u>0.20-0.26</u>	<u>50</u>	<u>Inches</u>	<u>1.0</u>	<u>1.5</u>	<u>1.5</u>	<u>1.5</u>	<u>1.5</u>	<u>1.5</u>	
			<u>R-value</u>	<u>R 8.5</u>	<u>R 14</u>	<u>R 12</u>	<u>R 10</u>	<u>R 9</u>		

**Footnote to TABLE 4-5:**

1. These thickness are based on energy efficiency considerations only. Issues such as water vapor permeability or surface condensation sometimes require vapor retarders or additional insulation.

From Table 120.3 A of the *Building Energy Efficiency Standards*

## 4.2.2 Prescriptive Requirements for Heating Equipment

### §150.1(c)6

Prescriptive component compliance requires the installation of a gas heating system or heat pump that meets the required minimum energy efficiency. (See Table 4-1 through Table 4-4)

Supplemental heating systems are allowed prescriptively, and the designer may elect to provide supplemental heating to a space such as a bathroom. In this instance, the supplemental heating system must be installed in a space that is served by the primary heating system and must have a thermal capacity of less than 2 kilowatts (kW) or 7,000 Btu/hr while being controlled by a time-limiting device not exceeding 30 minutes. Electric resistance and electric radiant heating installation are allowed as the primary heating system only when using the performance compliance method.

When using the prescriptive compliance approach, no additional credit is given for selecting equipment that is higher efficiency than what is required by the prescriptive component package.

## 4.2.3 Performance Compliance Options for Heating Equipment

### §150.1(b)3

There is one option for receiving compliance credit related to the heating system. This credit is available through the performance compliance method.

### 4.2.3.1 High-Efficiency Heating

Heating system efficiencies are explained in Section 4.2.1.1. The minimum efficiency is required for prescriptive compliance. When the performance compliance approach is used, additional compliance credit may be available from higher efficiency heating equipment which can be used to offset less efficient building features.

When a heat pump is providing space heating, if the efficiency used for compliance is higher than the minimum required HSPF, the system efficiency must be verified by a HERS Rater. Moreover, because the capacity of the heat pump affects the amount of back-up electric resistance heating required to attain and maintain comfort conditions, if the capacity proposed for compliance is different than the default capacity used in the performance compliance software, the Air Conditioning, Heating, and Refrigeration Institute (AHRI) ratings for heating capacity of the installed heat pump must be verified by a HERS Rater to confirm the heating

capacities at 47 degrees F and 17 degrees F are equal or greater than the heating capacities given on the certificate of compliance. See Residential Appendix RA3.4.4.2 for more information about this HERS verification

---

## 4.3 Cooling Equipment

This section addresses the requirements for space-cooling equipment.

### 4.3.1 Mandatory Measures for Cooling Equipment

#### 4.3.1.1 Equipment Efficiency

§110.1 and §110.2(a)
----------------------

The efficiency of most cooling equipment is regulated by NAECA (the federal appliance standard) and the California Appliance Efficiency Regulations. These regulations are not contained in the Energy Standards but are referenced in §110.1. The energy efficiency of larger equipment is regulated by §110.2(a). See the *Nonresidential Compliance Manual* for information on larger equipment.

#### **A. Central, Single-Phase Air Conditioners and Air Source Heat Pumps (Under 65,000 Btu/hr)**

The central, single-phase air conditioners and air source heat pumps that are most commonly installed in homes have a capacity less than 65,000 Btu/hr. The *Appliance Efficiency Regulations* for this equipment require minimum seasonal energy efficiency ratios (SEER).

The SEER of all new central, single-phase air conditioners and air source heat pumps with output less than 65,000 Btu/h shall be certified to the Energy Commission to have values no less than the values listed in Table 4-6.



**Table 4-6: Minimum Cooling Efficiencies for Central Air Conditioners and Heat Pumps (Cooling Capacity Less Than 65,000 Btu/hour) (NR = No Requirement)**

Appliance	Type	SEER	EER
Central Air Conditioners <sup>1</sup>	Split-System <45,000 Btuh	14	12.2
Central Air Conditioners <sup>1</sup>	Split-System ≥45,000 Btuh	14	11.7
Central Air Conditioners <sup>1</sup>	Single-Package	14	11.0
Central Air Source Heat Pumps	Split-System	14	NR
Central Air Source Heat Pumps	Single-Package	14	NR
Space-Constrained Air Conditioner	Split-System	12	NR
Space-Constrained Air Conditioner	Single-Package	12	NR
Space-Constrained Heat Pump	Split-System	12	NR
Space-Constrained Heat Pump	Single-Package	12	NR
Small-Duct, High-Velocity Air Conditioner	All	12	NR
Small-Duct, High-Velocity Heat Pump	All	12	NR

Source: *California Appliance Efficiency Regulations, Title 20, Table C-3* and Federal Appliance Standards (NAECA)

**B. Other Air Conditioners and Heat Pumps**

*Appliance Efficiency Regulations*

The current *Appliance Efficiency Regulations* for three-phase models, larger-capacity central air conditioners and heat pumps, and all room air conditioners and room air conditioner heat pumps shall be certified to the Energy Commission by the manufacturer to have values no less than the values listed in Table 4-7 and Table 4-8.

**Table 4-7: Minimum Cooling Efficiency for Three-Phase Models and Larger Capacity Central Air Conditioners and Heat Pumps**

Equipment Type	Size Category	SEER or EER
Central Air-Conditioners	< 65,000 Split-System*	13.0 SEER
Central Air-Conditioners	< 65,000 Single-Packaged*	13.0 SEER

Equipment Type	Size Category	SEER or EER
Central Air-Conditioners	≥65,000 Btu/h but <135,000 Btu/hr	11.2 <sup>1</sup> EER 11.0 <sup>2</sup> EER
Central Air-Conditioners	≥135,000 Btu/hr but <240,000 Btu/hr	11.0 <sup>1</sup> EER 10.8 <sup>2</sup> EER
Central Air-Conditioners	≥240,000 Btu/hr but <760,000 Btu/hr	10.0 <sup>1</sup> EER 9.8 <sup>2</sup> EER
Central Air-Source Heat Pumps	< 65,000 Split-System*	13.0 SEER
Central Air-Source Heat Pumps	< 65,000 Single-Packaged*	13.0 SEER
Central Air-Source Heat Pumps	≥ 65,000 Btu/h but <135,000 Btu/hr	11.0 <sup>1</sup> EER 10.8 <sup>2</sup> EER
Central Air-Source Heat Pumps	≥135,000 Btu/h but <240,000 Btu/hr	10.6 <sup>1</sup> EER 10.4 <sup>2</sup> EER
Central Air-Source Heat Pumps	≥240,000 Btu/h but <760,000 Btu/hr	9.5 <sup>1</sup> EER 9.3 <sup>2</sup> EER
Central Water-Source Heat Pumps	< 17,000 Btu/hr	11.2 EER
Central Water-Source Heat Pumps	≥ 17,000 Btu/h and < 65,000 Btu/hr	12.0 EER
Central Water-Source Heat Pumps	≥ 65,000 Btu/h and < 135,000 Btu/hr	11.9 EER
Central Water-Source Heat Pumps	≥ 135,000 Btu/h and < 240,000 Btu/hr	12.3 EER
Central Water-Source Heat Pumps	≥ 240,000 Btu/h and < 760,000 Btu/hr	12.2 EER
Water-Cooled Air Conditioners	< 17,000 Btu/hr	12.1 EER
Water-Cooled Air Conditioners	< 17,000 < 65,000 Btu/hr	12.1 EER
Water-Cooled Air Conditioners	≥ 65,000 Btu/hr and < 135,000 Btu/hr	12.1 <sup>3</sup> EER
Water-Cooled Air Conditioners	≥ 135,000 Btu/hr and < 240,000 Btu/hr	12.5 <sup>3</sup> EER
Water-Cooled Air Conditioners	≥ 240,000 Btu/hr and < 760,000 Btu/hr	12.4 <sup>3</sup> EER

\* Three-phase models only

1 Applies to equipment that has electric resistance heat or no heating.

2 Applies to equipment with all other heating-system types that are integrated into the unitary equipment. Deduct 0.2 from the required EER for units with heating sections other than electric resistance heat.

Source: California Appliance Efficiency Regulations Table C-4, C-5

**Table 4-8: Minimum Cooling Efficiency for Noncentral Space-Cooling Equipment**

<b>Equipment Type</b>	<b>Size Category (Input)</b>	<b>Minimum Efficiency</b>
Room Air Conditioners, With Louvered Sides	< 6,000 Btu/hr	11.0 EER
Room Air Conditioners, With Louvered Sides	≥ 6,000 Btu/hr and < 7,999 Btu/hr	11.0 EER
Room Air Conditioners, With Louvered Sides	≥ 8,000 Btu/hr and < 13,999 Btu/hr	10.9 EER
Room Air Conditioners, With Louvered Sides	≥ 14,000 Btu/hr and < 19,999 Btu/hr	10.7 EER
Room Air Conditioners, With Louvered Sides	≥ 20,000 Btu/h and < 27,999 Btu/h	9.4 EER
Room Air Conditioners, With Louvered Sides	≥ 28,000 Btu/h	9.0 EER
Room Air Conditioners, Without Louvered Sides	< 6,000 Btu/h	10.0 EER
Room Air Conditioners, Without Louvered Sides	≥ 6,000 Btu/hr and < 7,999 Btu/hr	10.0 EER
Room Air Conditioners, Without Louvered Sides	≥ 8,000 Btu/hr and < 10,999 Btu/hr	9.6 EER
Room Air Conditioners, Without Louvered Sides	≥ 11,000 Btu/hr and < 13,999 Btu/hr	9.5 EER
Room Air Conditioners, Without Louvered Sides	≥ 14,000 Btu/hr and < 19,999 Btu/hr	9.3 EER
Room Air Conditioners, Without Louvered Sides	≥ 20,000 Btu/hr	9.4 EER
Room Air Conditioner Heat Pumps With Louvered Sides	< 20,000 Btu/hr	9.8 EER
Room Air Conditioner Heat Pumps With Louvered Sides	≥ 20,000 Btu/hr	9.3 EER
Room Air Conditioner Heat Pumps Without Louvered Sides	< 14,000 Btu/hr	9.3 EER
Room Air Conditioner Heat Pumps Without Louvered Sides	≥ 14,000 Btu/hr	8.7 EER
Casement-Only Room Air Conditioner	All Capacities	9.5 EER
Casement-Slider Room Air Conditioner	All Capacities	10.4 EER
PTAC (cooling mode) Newly Constructed or Newly Conditioned Buildings or Additions	All Capacities	$14.0 - (0.300 \times \text{Cap}/1000) = \text{EER}$
PTAC (cooling mode) Replacements	All Capacities	$10.9 - (0.213 \times \text{Cap}/1000) = \text{EER}$
PTHP (cooling mode) Newly Constructed or newly conditioned buildings or Additions	All Capacities	$14.0 - (0.300 \times \text{Cap}/1000) = \text{EER}$
PTHP (cooling mode) Replacements	All Capacities	$10.8 - (0.213 \times \text{Cap}/1000) = \text{EER}$
SPVAC (cooling mode)	< 65,000 Btu/hr	11.0 EER
SPVAC (cooling mode)	≥ 65,000 Btu/hr and < 135,000 Btu/hr	10.0 EER

Equipment Type	Size Category (Input)	Minimum Efficiency
SPVAC (cooling mode)	≥ 135,000 Btu/hr and < 240,000 Btu/hr	10.0 EER
SPVHP (cooling mode)	< 65,000 Btu/hr	11.0 EER
SPVHP (cooling mode)	≥ 65,000 Btu/hr and < 135,000 Btu/hr	10 EER
SPVHP (cooling mode)	≥ 135,000 Btu/hr and < 240,000 Btu/hr	10 EER

Cap. = Cooling Capacity (Btu/hrr)

*Note:* Including room air conditioners and room air conditioner heat pumps, package terminal air conditioners (PTAC), package terminal heat pumps (PTHP), single-package vertical air conditioners (SPVAC), and heat pumps (SPVHP).

Source: *California Appliance Efficiency Regulations Title 20*, Table B-3, the Energy Standards Table 110.2-E

#### 4.3.1.2 Insulation for Refrigerant Lines in Split-System Air Conditioners

§150.0(j)2 and 3, §150.0(m)9

Two refrigerant lines connect the indoor and outdoor units of split-system air conditioners and heat pumps: the liquid line (the smaller diameter line) and the suction line (the larger diameter line).

If the liquid line is at an elevated temperature relative to outdoor and indoor temperatures, it should not be insulated. In those areas, heat escaping from it is helpful.

The suction line carries refrigerant vapor that is cooler than ambient in the summer and (with heat pumps) warmer than ambient in the winter. This line must be insulated to the required thickness (in inches) as specified in Table 4-9.

**Table 4-9: Insulation Requirements for Split-System Refrigerant Piping**

<u>Fluid Operating Temperature Range</u> (°F)	<u>Insulation Conductivity</u>			<u>Nominal Pipe Diameter (in inches)</u>	
	<u>Conductivity (in Btu·in/h·ft<sup>2</sup>·°F)</u>	<u>Mean Rating Temperature (°F)</u>		<u>≤ 1</u>	<u>1 to &lt;1.5</u>
<u>Space heating and Service Water Heating Systems (Steam, Steam Condensate, Refrigerant, Space Heating, Service Hot Water)</u>				<u>Minimum Pipe Insulation Required (Thickness in inches or R-value)</u>	
105-140	0.22-0.28	100	<u>Inches</u>	<u>1.0</u>	<u>1.5</u>
			<u>R-value</u>	<u>R 7.7</u>	<u>R 12.5</u>

<b>Space-Cooling Systems (Chilled Water, Refrigerant and Brine)</b>				<b>Minimum Pipe Insulation Required (Thickness in Inches or R-value)<sup>1</sup></b>			
<u>40-60</u>	<u>0.21-0.27</u>	<u>75</u>	<u>Inches</u>	<u>Nonres 0.5</u>	<u>Res 0.75</u>	<u>Nonres 0.5</u>	<u>Res 0.75</u>
			<u>R-value</u>	<u>Nonres R 3</u>	<u>Res R 6</u>	<u>Nonres R 3</u>	<u>Res R 5</u>
<u>Below 40</u>	<u>0.20-0.26</u>	<u>50</u>	<u>Inches</u>	<u>1.0</u>		<u>1.5</u>	
			<u>R-value</u>	<u>R 8.5</u>		<u>R 14</u>	

Footnote to TABLE 4-9:

1. These thickness are based on energy efficiency considerations only. Issues such as water vapor permeability or surface condensation sometimes require vapor retarders or additional insulation.

Source: Table 120.3-A of the Energy Standards

Insulation used for refrigerant suction lines located outside a condition space, must include a Class I or Class II vapor retarder. The vapor retarder and insulation must be protected from physical damage, UV deterioration, and moisture with a covering that can be removed for equipment maintenance without destroying the insulation. Insulation is typically protected by aluminum, sheet metal jacket, painted canvas, or plastic cover. Adhesive tape should not be used as insulation protection because removal of the tape will damage the integrity of the original insulation during preventive maintenance.

**Figure 4-1: Refrigerant Line Insulation**



Source: Airex Manufacturing Inc.

**4.3.1.3 Outdoor Condensing Units**

§150.0(h)3

Any obstruction of the airflow through the outdoor unit of an air conditioner or heat pump lowers efficiency. Dryer vents are prime sources for substances that clog outdoor coils and sometimes discharge substances that can cause corrosion. Therefore, condensing units shall not be placed within 5 feet of a dryer vent. This requirement is applicable to new installations and to replacements. Regardless of location, condenser coils should be cleaned regularly in all homes. The manufacturer installation instructions may include requirements for minimum horizontal and vertical distance to surrounding objects that should be met if greater than the minimum distance required by the Energy Standards.

**Figure 4-2: Noncompliant Condensing Unit Clearance From Dryer Vents**



Source: California Energy Commission

Liquid line filter driers are components of split system air-conditioners and split system heat pumps that are installed in the refrigerant line to remove moisture and particles, from the refrigerant stream. These contaminants may be introduced in the refrigerant as a result of improper flushing, evacuation, and charging procedures, causing the efficiency and capacity of the air conditioner to be impaired, or damaging components. If required by manufacturer's instructions, liquid line filter driers must be installed. Sometimes, liquid line filter driers are preinstalled by manufacturers within condensing units, which makes it difficult for technicians to access. Because of this difficulty, manufacturers have begun changing this practice by installing liquid line filter driers outside condensers, so that they can be easily serviced by technicians and more easily verified by HERS Raters.

The quality of the filter dryer installation impacts the effectiveness of the liquid line filter dryer, as some liquid line filter driers can be installed without regard to the direction of refrigerant flow. Heat pumps, for example, allow refrigerant flow in both directions. However, in other air conditioners where refrigerant flow occurs in only one direction, correct orientation of the liquid line filter dryer is important.

#### 4.3.1.4 Equipment Sizing

§150.0(h)

Similar to heating equipment, the Energy Standards do not set limits on the size of cooling equipment, but they do require that cooling loads be calculated for new cooling systems. Avoid oversizing the cooling components since oversizing may adversely affect the efficiency of the system. Ducts must be sized correctly, otherwise the system airflow rate may be restricted, adversely affecting the efficiency of the system and preventing the system from meeting the mandatory minimum airflow rate requirements.

The outdoor design conditions for load calculations must be selected from Reference Joint Appendix JA2, Table 2-3, using values no greater than the “1.0 percent cooling dry bulb” and “mean coincident wet bulb” values listed. The indoor design temperature for cooling load calculations must be 75°F. Acceptable load calculation procedures include methods described in:

1. *The ASHRAE Handbook – Equipment*
2. *The ASHRAE Handbook – Applications*
3. *The ASHRAE Handbook – Fundamentals*
4. The SMACNA Residential Comfort System Installation Manual.
5. *ACCA Manual J*

Cooling load calculations must be submitted with compliance documentation when requested by the building department. The load calculations may be prepared by 1) a mechanical engineer, 2) the mechanical contractor who is installing the equipment or 3) someone who is qualified to do so in the State of California according to Division 3 of the Business and Professions Code.

#### 4.3.1.5 Hole for Static Pressure Probe (HSPP) or Permanently Installed Static Pressure Probe (PSPP)

§150.0(m)13

Space-conditioning systems that use forced air ducts to cool occupiable space shall have a hole for the placement of a static pressure probe (HSPP) or permanently installed static pressure probe (PSPP) installed downstream from the evaporator coil.

The HSPP or PSPP must be installed in the required location, in accordance with the specifications detailed in Reference Residential Appendix RA3.3. The HSPP or PSPP is required to promote system airflow measurement when using devices/procedures that depend on supply plenum pressure measurements. The HSPP or PSPP allows HERS Raters to perform the required diagnostic airflow testing in a nonintrusive manner, by eliminating the necessity for the raters to drill holes in the supply plenum for placement of pressure measurement probes.

The size and placement of the HSPP/PSPP shall be in accordance with RA3.3.1.1 and shall be verified by a HERS Rater. In the event that the HSPP/PSPP cannot be installed as shown in Figure RA3.3-1 because of the configuration of the system or that the location is not accessible, an alternative location may be provided that can accurately measure the average static pressure in the supply plenum. If an

alternative location cannot be provided, then the HSPP/PSPP is not required to be installed. The HERS Rater will verify this. Not installing an HSPP/PSPP will limit the airflow measurement method to either a powered flow hood or passive (traditional) flow hood.

When the mandatory measure for minimum system airflow rate is in effect (entirely new systems), there must be a hole in the supply plenum, provided by the installing contractor, for the placement of a static pressure probe (HSPP). Alternatively, a permanently installed static pressure probe (PSPP) must be installed in the same location.

This requirement also applies when the plenum pressure matching method or the flow grid method of airflow measurement is used by either the installer or the rater to verify airflow in an altered system. The HSPP/PSPP must be installed by the installer, not the rater.

See Air Distribution Ducts, Plenums, and Fans Section 4.4 for discussion regarding mandatory sizing/airflow requirements for ducted systems with cooling.

### 4.3.2 Prescriptive Requirements for Cooling Equipment

§150.1(c)7
------------

Prescriptive compliance does not require that a cooling system be installed. However, if one is to be installed, the cooling equipment efficiency requirements are specified by the mandatory measures (See Section 4.3.1 above)

Using the prescriptive compliance approach, no additional credit is given for selecting equipment that is higher than what is required by the prescriptive component package.

Prescriptive requirements for air-cooled air conditioners and air-source heat pumps installed in Climate Zones 2 and 8 through 15 necessitates the installation of a measurement access hole (MAH), refrigerant charge verification (RCV), and minimum system airflow verification. The minimum system airflow installation and RCV must be performed by the installer and/or HERS Rater. The MAH provides a nonintrusive means of measuring return air temperature, which is a parameter important to the RCV process. The alternative to RCV by a HERS Rater is the installation of a refrigerant fault indicator display. When installing a fault indicator display, the installer must still perform a RCV.

*Note:* The refrigerant charge verification is discussed below (4.3.2.3) and in greater detail later in Section 4.8.

#### 4.3.2.1 Measurement Access Hole (MAH).

The MAH provides a nonintrusive means for refrigerant charge verification by HERS Raters and other third-party inspectors. They eliminate the need for raters/inspectors to drill holes into the installed air conditioning equipment enclosures for placement of the temperature sensors required by the refrigerant charge verification test procedures described in the Reference Residential Appendix RA3.2.



Installation of MAH must be performed by the installer of the air conditioner or heat pump equipment according to the specifications given in Reference Residential Appendix RA3.2.

The MAH feature consists of one 5/8-inch (16 millimeters [mm]) diameter hole in the return plenum, upstream from the evaporator coil. (See Figure RA3.2-1 in Reference Residential Appendix RA3.2.)

#### 4.3.2.2 Minimum System Airflow

Ducted forced air cooling systems must comply with the minimum system airflow rate of greater than or equal to 350 CFM per ton, or 250 CFM/ton for small duct, high velocity systems, when performing the refrigerant charge verification. The airflow is important when performing the refrigerant charge verification to validate the measured values for pressure and temperature. The correct airflow will also improve the performance of the air-conditioning equipment.

The airflow verification procedure is documented in Reference Residential Appendix RA3.3.

#### 4.3.2.3 Refrigerant Charge Verification (RCV)

The prescriptive standards for Climate Zones 2 and 8-15 require that a HERS rater verify that ducted air-cooled air conditioners, ducted air-source heat pumps, small-duct high-velocity systems; and mini-split systems have the correct refrigerant charge. The RCV procedures are documented in Reference Residential Appendix RA1.2, RA2.4.4, and RA3.2.

*Refrigerant charge* refers to the actual amount of refrigerant present in the system. Excessive refrigerant charge (overcharge) reduces system efficiency and can lead to premature compressor failure. Insufficient refrigerant charge (undercharge) also reduces system efficiency and can cause compressors to overheat. Ensuring correct refrigerant charge can significantly improve the performance of air-conditioning equipment. *Refrigerants* are the working fluids in air-conditioning and heat-pump systems that absorb heat energy from one area (through the evaporator), transfer, and reject it to another (through the condenser).

#### 4.3.2.4 Fault Indicator Display

The installation of a fault indicator display (FID) may be used as an alternative to the prescriptive requirement for HERS diagnostic testing of the refrigerant charge in air conditioners and heat pumps. The installation of an FID does not preclude the HVAC installer from having to properly charge the system with refrigerant. The FID provides real-time information to the building occupant about the status of the system refrigerant charge, metering device, and system airflow. The FID will monitor and determine the operating performance of air conditioners and heat pumps and provide visual indication to the system owner or operator if the refrigerant charge, airflow, or metering device performance of the system does not conform to approved target parameters for minimally efficient operation. Thus, if the FID signals the owner/occupant that the system requires service or repair, the occupant can

immediately call for a service technician to make the necessary adjustments or repairs. An FID can provide significant benefit to the owner/occupant by alerting the owner/occupant to the presence of inefficient operation that could result in excessive energy use/costs over an extended period. An FID can also indicate system performance faults that could result in system component damage or failure if not corrected, thus helping the owner/occupant avoid unnecessary repair costs.

Fault indicator display technologies are expected to be installed at the factory; otherwise, they may be installed in the field according to manufacturer's specifications. Reference Joint Appendix JA6 contains more information about FID technologies.

The presence of an FID on a system must be field-verified by a HERS Rater. See Reference Residential Appendix RA3.4.2 for the HERS verification procedure, which consists of a visual verification of the presence of the installed FID technology. The rater must inspect to see that the visual indication display component of the installed FID technology is mounted adjacent to the thermostat of the split system. When the outdoor temperature is greater than 55°F, the rater must also observe that the system reports no system faults when the system is operated continuously for at least 15 minutes when the indoor air temperature returning to the air conditioner is at or above 70°F. When the outdoor temperature is below 55°F, the rater must observe that the FID performs a self-diagnosis and indicates that the sensors and internal processes are operating properly.

### **4.3.3 Performance Compliance Options for Cooling Equipment**

There are several options for receiving compliance credit related to the cooling system. These credits are available through the performance compliance method.

#### **4.3.3.1 High-Efficiency Air Conditioner**

Air conditioner efficiencies are determined according to federal test procedures. The efficiencies are reported in terms of seasonal energy efficiency ratio (SEER) and energy efficiency ratio (EER). Savings can be achieved by choosing an air conditioner that exceeds the minimum efficiency requirements.

The EER is the full-load efficiency at specific operating conditions. It is possible that two units with the same SEER can have different EERs. In cooling climate zones of California, for two units with a given SEER, the unit with the higher EER is more effective in saving energy. Using the performance compliance method, credit is available for specifying an air conditioner with an EER greater than the minimum (Table 4-6). When credit is taken for a high EER and/or SEER, field verification by a HERS Rater is required. (See Reference Residential Appendix RA3.4.4).

#### **4.3.3.2 Air Handler Fan Efficacy and System Airflow**

It is mandatory that central forced-air systems operate at fan efficacy values less than or equal to

- 0.58 watts/CFM for air handlers that are not gas furnaces.

- 0.45 watts/CFM for gas furnaces.
- 0.62 watts/CFM for small-duct high-velocity system air handlers.

These central forced-air systems also must operate at airflow rates of at least 350 CFM per nominal cooling ton, or 250 CFM/ton for small-duct high-velocity systems. Performance compliance credits are available for demonstrating the installation of a high-efficiency system with a lower fan wattage and/or higher airflow than the mandatory requirements. Compliance with these credits can be achieved by installing a well-designed duct system and can be assisted by a high-efficiency fan. There are two possible performance compliance credits:

1. The performance compliance method allows the user's proposed fan efficacy to be entered and credit earned if it is lower than the default mandatory values. To obtain this credit for a system with cooling, the system airflow must meet the mandatory requirement of at least 350 CFM/ton of nominal cooling capacity.
2. The performance compliance method allows the user's proposed system airflow to be entered and credit earned if it is higher than the default of 350 CFM/ton of nominal cooling capacity. To obtain this credit, the fan efficacy must meet the mandatory requirements listed above.

#### 4.3.3.3 Whole-House Fan Ventilation Cooling

A whole-house fan (WHF) is not a mandatory requirement. It is required in some climate zones when using prescriptive compliance. The three performance compliance options are the following:

1. No WHF is assumed in the performance compliance software (no ventilation cooling). This will be either energy-neutral, or there will be an energy penalty if the applicable climate zone assumes the effects of a WHF.
2. A default WHF means this proposed feature is equivalent to the standard feature used to establish the energy budget of the building (The performance of the fan is derated to account for deficiencies from installing undersized or inefficiently designed WHF).
3. The HERS-verified WHF option allows for modeling the effects of the WHF without derating the system performance. The HERS-verified option also allows modeling a WHF with a higher airflow rate or lower fan efficacy than the default, which improves the compliance credit.

#### 4.3.3.4 Central Fan Ventilation Cooling

Central fan ventilation cooling (CFVC) performs a function similar to a WHF using the central space-conditioning ducts to distribute outside air. When using the performance compliance approach, a CFVC system may be selected in the compliance software instead of a conventional whole-house fan. Three compliance options are:

1. No CFVC is assumed in the performance compliance software (no ventilation cooling). This will be either energy-neutral, or an energy penalty will be assessed if the applicable climate zone assumes the effects of a WHF.
2. A default CFVC system means the proposed system is equivalent in size and features to a derated WHF.
3. The HERS verified CFVC system option allows for the effects of the system without derating system performance. It also allows for modeling a system with greater capacity, a higher airflow rate or lower fan efficacy than default.

After installation, the contractor must test the actual fan power and airflow of the system using the procedure in *Reference Residential Appendix RA3.3* and show that it is equal or better than what was proposed in the compliance software analysis.

Field verification by a HERS Rater is required. (See Reference Residential Appendix RA3.3.)

---

#### **4.4 Air Distribution System Ducts, Plenums, Fans, and Filters**

Air distribution system performance can have a big effect on overall HVAC system efficiency. Therefore, air distribution systems are required to meet several mandatory and prescriptive requirements as discussed below.

The *2019 Energy Standards* specify mandatory requirements for air distribution ducts to be sealed and tested in all climate zones. There are also several compliance credits available related to duct system design.

Duct efficiency is affected by the following parameters:

1. Duct location (attic, crawlspace, basement, inside conditioned space, or other)
2. Specific conditions in the unconditioned space, for example, presence of a radiant barrier
3. Duct insulation characteristics
4. Duct surface area
5. Air leakage of the duct system

In performance calculations, duct efficiency can be calculated in one of two ways:

1. Default input assumptions
2. Diagnostic measurement values

The computer program will use default assumptions for the proposed design when the user does not intend to make improvements in duct efficiency.

#### 4.4.1 Mandatory Measures for Air Distribution System Ducts, Plenums, Fans, and Filters

##### 4.4.1.1 Minimum Insulation

###### §150.0(m)1

Ducts that are installed entirely in conditioned space must have an R-value of R-4.2, except for some portions of a duct system in wall cavities inside the thermal envelope, or in directly conditioned space (see Exceptions 1 and 2 to Section 150.0(m)1). In all other cases, the minimum allowed duct insulation value is R-6. Higher values may be required by the prescriptive requirements, as described below.

To determine whether ducts are entirely in conditioned space as defined in §100.1, a rater must field verify by visual inspection and by using the protocols of RA 3.1.4.3.8.

RA 3.1.4.3.8 describes the duct leakage to outside test that determines whether the ducts are within the pressure boundary of the space being served by the duct system. Also, a basic visual inspection of the ducts is required to ensure that no portion of the duct system is obviously outside the apparent pressure/thermal boundary.

Leakage to “outside” means conditioned air leaking from the ducts to anywhere outside the pressure boundary of the dwelling unit conditioned space served by the duct system, which includes leakage to outside the building, and leakage to adjacent dwelling units.

Exception to §150.0(m)1: Ducts and fans integral to a wood heater or fireplace are exempt from §150.0(m)1.

###### §150.0(m)5

For determining the installed R-value of duct insulation based on thickness, when not an integral part of a manufacturer-labeled, insulated duct product such as vinyl flex duct, the following shall be used:

1. For duct wrap, the installed thickness of insulation must be assumed to be 75 percent of the nominal thickness due to compression.
2. For duct board, duct liner, and factory-made rigid ducts not normally subjected to compression, the nominal insulation thickness shall be used.

##### 4.4.1.2 Connections and Closures

###### §150.0(m)1 - §150.0(m)3

The Energy Standards set a number of mandatory measures related to duct connections and closures. These measures address the materials and methods used for duct sealing. The following is a summary. Refer to the sections of the Energy Standards listed above for details.

#### 4.4.1.3 Factory-Fabricated Duct Systems

Factory-fabricated duct systems must comply with the following requirements:

1. All factory-fabricated duct systems must comply with UL 181 for ducts and closure systems, including collars, connections, and splices, and be labeled as complying with UL 181.
2. All pressure-sensitive tapes, heat-activated tapes, and mastics used in the manufacture of rigid fiberglass ducts must comply with UL 181 and UL 181A.
3. All pressure-sensitive tapes and mastics used with flexible ducts must comply with UL 181 and UL 181B.
4. Joints and seams of duct systems and related components cannot be sealed with cloth-backed rubber adhesive duct tapes unless such tape is used in combination with mastic and draw bands, or
5. It has on its backing the phrase "CEC approved," a drawing of a fitting to plenum joint in a red circle with a slash through it (the international symbol of prohibition), and a statement that it cannot be used to seal fittings to plenums and junction box joints.

#### 4.4.1.4 Field-Fabricated Duct Systems

Field-fabricated duct systems must comply with the following requirements:

1. Factory-made rigid fiberglass and flexible ducts for field-fabricated duct systems must comply with UL 181. All pressure-sensitive tapes, mastics, aerosol sealants, or other closure systems used for installing field-fabricated duct systems shall meet the applicable requirements of UL 181, UL 181A, and UL 181B.
2. Mastic sealants and mesh:
  - a. Sealants must comply with the applicable requirements of UL 181, UL 181A, and/or UL 181B and be nontoxic and water-resistant.
  - b. Sealants for interior applications must be tested in accordance with ASTM C731 and D2202.
  - c. Sealants for exterior applications must be tested in accordance with ASTM C731, C732, and D 2202.
  - d. Sealants and meshes must be rated for exterior use.
3. Pressure-sensitive tapes must comply with the applicable requirements of UL 181, UL 181A, and UL 181B.
4. Joints and seams of duct systems and their components must not be sealed with cloth-backed rubber adhesive duct tapes unless such tape is used in combination with mastic and draw bands, or

5. It has on its backing the phrase "CEC approved," a drawing of a fitting to plenum joint in a red circle with a slash through it (the international symbol of prohibition), and a statement that it cannot be used to seal fittings to plenums or junction box joints.

#### 4.4.1.5 Draw Bands Used With Flexible Duct

1. Draw bands must be either stainless-steel worm-drive hose clamps or UV-resistant nylon duct ties.
2. Draw bands must have a minimum tensile strength rating of 150 pounds.
3. Draw bands must be tightened as recommended by the manufacturer with an adjustable tensioning tool.

#### 4.4.1.6 Aerosol-Sealant Closures

1. Aerosol sealants shall meet the requirements of UL 723 and be applied according to manufacturer specifications.
2. Tapes or mastics used in combination with aerosol sealing shall meet the requirements of this section.

If mastic or tape is used to seal openings greater than 1/4 inch, the combination of mastic and either mesh or tape must be used.

Building spaces such as cavities between walls, support platforms for air handlers, and plenums defined or constructed with materials other than sealed sheet metal, duct board, or flexible duct must not be used for conveying conditioned air, including return air and supply air. Using drywall materials as the interior surface of a return plenum is not allowed. Building cavities and support platforms may contain ducts. Ducts installed in cavities and support platforms must not be compressed to cause reductions in the cross-sectional area of the ducts. Although a HERS Rater may examine this as a part of his or her responsibilities when involved in a project, the enforcement of these minimum standards for ducts is the responsibility of the building official.

*§150.0(m)2D, §150.0(m)3D*

Duct systems may not use cloth-backed, rubber-adhesive duct tape (typical, "old fashioned," nonrated duct tape) unless it is installed in combination with mastic and draw bands. Mastic and drawbands alone are adequate for sealing most connections. Cloth-backed, rubber-adhesive duct tape may be used to hold the outer vapor barrier in place or for some purpose other than prevention of duct leakage. Cloth-backed rubber adhesive duct tape alone is not adequate to serve as an air-sealing method or as a mechanical connection.

The enforcement of these minimum standards is normally the responsibility of the building official; however, HERS Raters will also verify compliance with this requirement in conjunction with duct leakage verification.

#### 4.4.1.7 Product Markings

§150.0(m)2A, §150.0(m)6

All factory-fabricated duct systems must meet UL 181 for ducts and closure systems and be labeled as complying with UL 181. Collars, connections, and splices are considered to be factory-fabricated duct systems and must meet the same requirement.

Insulated flexible duct products installed to meet this requirement must include labels, in maximum intervals of 3 ft, showing the R-value for the duct insulation (excluding air films, vapor barriers, or other duct components), based on the tests and thickness specified in §150.0(m)4 and §150.0(m)5C.

#### 4.4.1.8 Dampers to Prevent Air Leakage

§150.0(m)7

Fan systems that exhaust air from the building to the outside must be provided with back draft or automatic dampers.

§150.0(m)8

Gravity ventilating systems must have an automatic or readily accessible, manually operated damper in all openings to the outside, except combustion inlet and outlet air openings and elevator shaft vents. This includes clothes dryer exhaust vents when installed in conditioned space.

#### 4.4.1.9 Protection of Insulation

§150.0(m)9

Insulation must be protected from damage, including damage from sunlight, moisture, equipment maintenance, and wind, but not limited to the following:

1. Insulation exposed to weather must be suitable for outdoor service – for example, protected by aluminum, sheet metal, painted canvas, or plastic cover.
2. Cellular foam insulation shall be protected as above or painted with a coating that is water-retardant and shields from solar radiation that can degrade the material.

#### 4.4.1.10 Ducts in Concrete Slab

Ducts in a concrete slab must have R-6 insulation, but other issues will come into play. If ducts are in the soil beneath the slab or embedded in the slab, the insulation material should be designed and rated for such installation. Insulation installed in below-grade applications should resist moisture penetration. (Closed-cell foam is one moisture-resistant product.) Common premanufactured duct systems are not suitable for below-grade installations. If concrete is to be poured directly over the



ducts, then the duct construction and insulation system should be sturdy enough to resist the pressure and not collapse. Insulation should be of a type that will not compress, or it should be inside a rigid duct enclosure. The only time that common flex ducts are suitable in a below-grade application is when a channel is provided in the slab.

#### 4.4.1.11 Porous Inner Core Flex Duct

§150(m)10

Over time, the outer vapor barrier of flex duct can degrade and be easily damaged. Therefore, porous inner core flex duct must have a non-porous layer or air barrier between the inner core and the outer vapor barrier.

#### 4.4.1.12 Duct System Sealing and Leakage Testing

§150(m)11

Duct system sealing and leakage testing is mandatory in all climate zones. Duct systems in newly constructed single-family dwellings, townhouses, and multifamily dwellings are required to comply with the requirements. For single-family dwellings and townhouses where the air-handling unit is installed and ducts are connected directly to the air handler, the total leakage of the duct system must be 5 percent or less of the nominal system air handler airflow. For single-family dwellings and townhouses inspected at the "rough-in" stage of construction, where the air-handling unit is not installed, the total leakage of the duct system shall not exceed 4 percent of the nominal systems air handler airflow.

For multifamily dwellings with the air-handling unit installed and the ducts connected directly to the air handler, the total leakage of the duct system shall not exceed 12 percent of the nominal system air handler airflow or the duct system leakage to outside shall not exceed 6 percent of the nominal system air handler airflow.

The duct system leakage must be verified according to the applicable procedures outlined in Reference Residential Appendix Section RA3.1.4.

Alterations and additions to ducted systems in existing buildings in all climate zones are also required to comply with applicable maximum leakage criteria. Refer to Chapter 9 for more information on duct sealing and leakage testing for existing buildings.

#### 4.4.1.13 Duct Leakage Testing for Multiple Duct Systems With Common Return Ducts

If there are two or more duct systems in a building that are tied together at a common return duct, then each duct system should be tested separately, including the shared portion of the return duct system in each test. Under this scenario, the portions of the second duct system that is not being tested must be completely isolated from the portions of the ducts that are being tested, so the leakage from

second duct system does not affect the leakage rate from the side that is being tested.

Figure 4-3 represents the systems that are attached to a shared return boot or remote return plenum. In this case, the point in the return system that needs to be blocked off is readily accessible through the return grille.

The “duct leakage averaging,” where both systems are tested together as though it is one large system and divided by the combined tonnage to get the target leakage, may not be used as it allows a duct system with more the 5 percent leakage to pass if the leakage of the combined system is 5 percent or less.

**Figure 4-3: Two Duct Systems With a Common Return Duct**

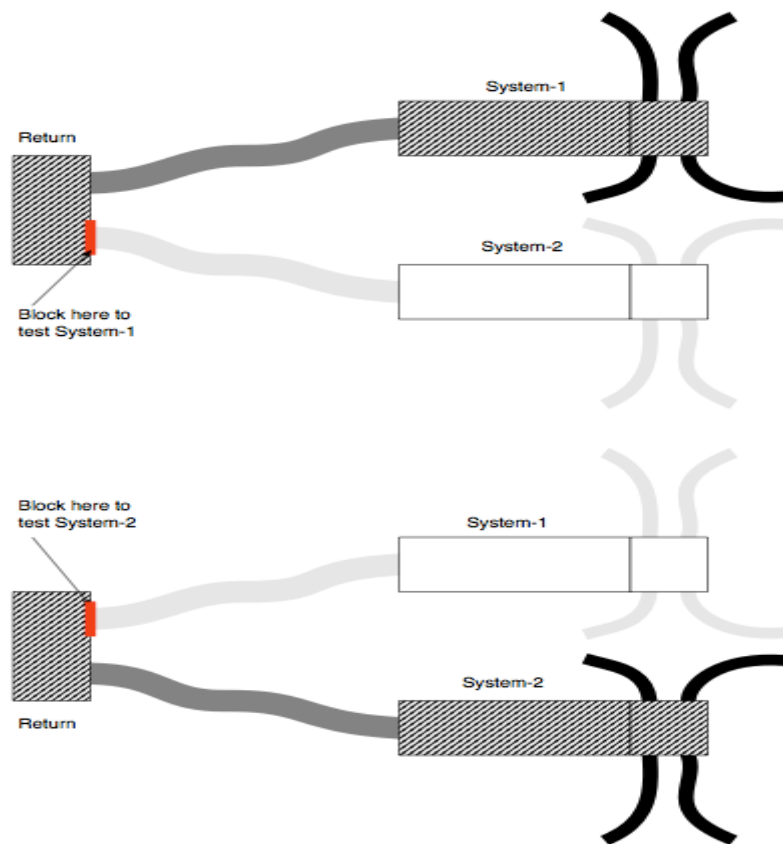

Source: California Energy Commission

#### 4.4.1.14 Air Filtration

§150.0(m)12

Air filtration is used in forced air systems to protect the equipment from dust accumulation that could reduce the capacity or efficiency of the system. Preventing dust buildup may also prevent the system from becoming a host to biological contaminants such as mold, especially if dust is deposited on cooling coils that

become wet from water condensation during comfort cooling operation. Air filter efficiencies of Minimum Efficiency Reporting Value (MERV) 6 to MERV 8 are sufficient for protection from these large airborne dust particles. Air filter efficiencies of at least MERV 13 are needed to protect occupants from exposure to the smaller airborne particles that are known to adversely affect respiratory health. These smaller particles are often referred to as PM 2.5 which refers to particulate matter of 2.5 microns. PM2.5 is produced from combustion such as that resulting from cooking in the kitchen and from exhaust from motor vehicles that enters a dwelling through ventilation openings and infiltration.

#### 4.4.1.14.1 Air Filter Pressure Drop

Standards Section 150.0(m)12Bii requires all systems to be designed to accommodate the clean-filter pressure drop imposed by the system air filter device(s). This applies to space-conditioning systems and to the ventilation system types described in Section 4.4.1.14.2 below. The design airflow rate, and maximum allowable clean-filter pressure drop at the design airflow rate applicable to each air filter device shall be determined and posted on a sticker or label by the installer inside the filter grille or near the filter rack, according to Section 4.4.1.14.5 below.

Designers of space-conditioning systems must determine the total of the system external static pressure losses from filters, coils, ducts, and grilles, such that the sum is not greater than the available static pressure of the air handling unit at the design airflow rate. Therefore, air filters should be sized to minimize static pressure drop across the filter during system operation. The air filter pressure drop can be reduced by increasing the amount of air filter media surface area available to the system airflow. Increased media surface area can be accomplished by adjusting one, two, or all three of the following factors:

- a. Adjust the number of pleats of media per inch inside the air filter frame. The number of pleats per inch inside the filter frame is determined by the manufacturer's filter model design and is held constant for all filter sizes of the same manufacturer's model. For example, all 3M Filtrete 1900 filters will have the same media type, the same MERV rating, and the same number of pleats of media per inch inside the filter frame regardless of whether the nominal filter size is 20" X 30" or 24" X 24", and so forth. Generally, as the number of pleats per inch is increased, the pressure drop is reduced if all other factors remain constant. The pressure drop characteristics of air filters vary widely between air filter manufacturers and between air filter models, largely because of the number of pleats per inch in the manufacturer's air filter model design. System designers and system owners cannot change the manufacturer's filter model characteristics, but they can select a superior air filter model from a manufacturer that provides greater airflow at a lower pressure drop by comparing the filter pressure drop performance shown on the air filter manufacturer's product label (see example label in Figure 4-5).
- b. Adjust the face area of the air filter and filter grille. Face area is the nominal cross-sectional area of the air filter, perpendicular to the direction of the

airflow through the filter. Face area is also the area of the filter grille opening in the ceiling or wall. The face area is determined by multiplying the length times width of the filter face (or filter grille opening). The nominal face area for a filter corresponds to the nominal face area of the filter grille in which the filter is installed. For example, a nominal 20" X 30" filter has a face area of 600 in<sup>2</sup> and would be installed in a nominal 20" X 30" filter grille. Generally, as the total system air filter face area increases, the pressure drop is reduced if all other factors remain constant. Total system air filter face area can be increased by specifying a larger area filter/grille, or by using additional/multiple return filters/grilles, summing the face areas. The filter face area is specified by the system designer or installer.

- c. Adjust the depth of the filter and filter grille. Air filter depth is the nominal filter dimension parallel to the direction of the airflow through the filter. Nominal filter depths readily available for purchase include one, two, four, and six inches. Generally, as the system air filter depth increases, the pressure drop is reduced if all other factors remain constant. For example, increasing filter depth from one inch to two inch nominally doubles the filter media surface area without increasing the filter face area. The filter depth is specified by the system designer or installer.

#### 4.4.1.14.2 Air Filter Particle Removal Efficiency Requirements – MERV 13

An air filter with a particle removal efficiency equal to or greater than MERV 13, or a particle size efficiency rating equal to or greater than 50 percent in the 0.30-1.0 µm range, and equal to or greater than 85 percent in the 1.0-3.0 µm range is required for the following systems:

- a. Mechanical space conditioning (heating or cooling) systems with a total of more than 10 feet of duct. The total is determined by summing the lengths of all the supply and return ducts for the forced-air system.
- b. Mechanical supply-only ventilation systems that provide outside air to an occupiable space.
- c. The supply side of mechanical balanced ventilation systems, including heat recovery ventilation systems and energy recovery ventilation systems that provide outside air to an occupiable space.

Evaporative coolers are exempt from the air filtration requirements

#### 4.4.1.14.3 Air Filter Requirements for Space-Conditioning Systems:

Space-conditioning systems may use any of the three following compliance approaches:

- a. Install a filter grille or accessible filter rack that accommodates a minimum 2-inch depth filter and install the appropriate filter.

- b. Install a filter grille or accessible filter rack that accommodates a minimum 1" depth filter and install the appropriate filter. The filter/grille must be sized for a velocity of  $\leq 150$  ft per minute. The installed filter must be labeled to indicate the pressure drop across the filter at the design airflow rate for that return is  $\leq 0.1$  inch water column (w.c. [25 PA]).

Use the following method to calculate the 1" depth filter face area required. Divide the design airflow rate (ft<sup>3</sup>/min) for the filter grille/rack by the maximum allowed face velocity 150 ft/min. This yields a value for the face area in ft<sup>2</sup>. Since air filters are sold using nominal sizes in terms of inches, convert the face area to in<sup>2</sup> by multiplying the face area (ft<sup>2</sup>) by a conversion factor of 144 in<sup>2</sup>/ft<sup>2</sup>. Summarizing:

$$\text{Filter Nominal Face Area (in}^2\text{)} = \text{airflow (CFM)} \div 150 \times 144$$

- c. Comply with Standards Tables 150.0-B and C (Table 4-10 and Table 4-11), which prescribe the minimum total system nominal filter face area and return duct size(s). The installed filter must be labeled to indicate the pressure drop across the filter at the design airflow rate for that return is  $\leq 0.1$  inch w.c. (25 PA). This option is an alternative to the Section 150.0(m)13 requirement for HERS-verified fan efficacy and airflow rate but requires instead a HERS verification of the return duct design.

#### 4.4.1.14.4 Air Filter Requirements for Ventilation Systems

- a. Filters with a depth of 1" or greater are allowed.
- b. The design airflow rate, and maximum allowable clean-filter pressure drop at the design airflow rate applicable to each air filter device must be determined by the system designer or installer and that information must be posted on a sticker by the installer inside or near the filter grille/rack according to Section 4.4.1.14.5 below.
- c. Ventilation systems must deliver the volume of air specified by §150.0(o) with filters in place.

#### 4.4.1.14.5 Filter Access and Filter Grille Sticker – Design Airflow and Pressure Drop

All filters used in all system types must be accessible to facilitate replacement.

- a. **Air filter grille sticker.** The design airflow rate and maximum allowable clean-filter pressure drop at the design airflow rate applicable to each air filter grille/rack must be determined by the designer/installer and posted on a sticker placed by the installer inside or near the filter grille/rack. The design airflow and initial resistance posted on this sticker should correspond to the conditions used in the system design calculations. This requirement applies to space conditioning systems and to the ventilation system types described in Section 4.4.1.14.2 above.

An example of an air filter grille sticker showing the design airflow and pressure drop for the filter grille/rack is shown in Figure 4-4.

- b. **Air filter manufacturer label.** Space-conditioning system filters are required to be labeled by the manufacturer to indicate the pressure drop across the filter at several airflow rates. For the system to comply, and to ensure adequate airflow for efficient heating and cooling equipment operation, the manufacturer's air filter label (Figure 4-5) must display information that indicates the filter can meet the design airflow rate for that return grille/rack at a pressure drop  $\leq$  the value shown on the installer's filter grille sticker (Figure 4-4). This requirement does not apply to the ventilation system types described in Section 4.4.1.14.2.

**Figure 4-4: Example of Installer's Filter Grille Sticker**

Air Filter Performance Requirement	Air Filter Performance Requirement	Maintenance Instructions
<b>Airflow Rate (CFM)</b> Must be greater than or equal to the value shown	<b>Initial Resistance (IWC)</b> Must be less than or equal to the value shown	Use only replacement filters that are rated to simultaneously meet both of the performance requirements specified on this sticker:
750	0.1	

Source: California Energy Commission

**Figure 4-5: Example Manufacturer's Filter Label**

MERV	( $\mu$ m)	0.30-1.0	1.0-3.0	3.0-10	Airflow Rate (CFM)	615	925	1230	1540	2085*	*Max Rated Airflow
13	PSE (%)	62	87	95	Initial Resistance (IWC)	0.07	0.13	0.18	0.25	0.38	

Source: California Energy Commission

#### 4.4.1.14.6 Air Filter Selection

For a filter to meet the system specifications for airflow and pressure drop, it must be rated by the manufacturer to provide more than the specified airflow at less than the specified pressure drop. It is unlikely that a filter will be available that is rated to have the exact airflow and pressure drop ratings specified, so filters should be selected that are rated to have less than the specified pressure drop at the specified airflow rate, otherwise select filters that are rated to have greater than the specified airflow rate at the specified pressure drop. See Figure 4-4 for an example of an installer's filter grille sticker that provides an air filter rating specification for minimum airflow of 750 CFM at maximum pressure drop 0.1 inch w.c.

Manufacturers of air filters may make supplementary product information available to consumers that will assist with selecting the proper replacement filters. This product information may provide more detailed information about the filter model airflow and pressure drop performance – details such as airflow and pressure drop values that are intermediate values that lie between the values shown on their product label. The information may be published in tables, graphs, or presented in software applications available on the internet or at the point of sale.

Figure 4-6 below shows a graphical representation of the initial resistance (pressure drop) and airflow rate ordered pairs given on the example air filter manufacturer's label shown in Figure 4-5 above. The graph in Figure 4-6 makes it possible to visually determine the airflow at 0.1 inch w.c. pressure drop for which the values are not shown on the manufacturer's filter label.

If there is no supplementary manufacturer information available, and it is necessary to determine the performance of a filter model at an airflow rate or pressure drop between two values shown on a manufacturer's label, linear interpolation may be used. Linear interpolation apps are readily available on the internet, and formulas for linear interpolation are shown below.

The linear interpolation method may be used to determine an unknown pressure drop corresponding to a known airflow rate by use of Equation 4-1a, or it may also be used to determine an unknown airflow rate corresponding to a known pressure drop by use of Equation 4-1b.

$$p = p_1 + [(f-f_1) \div (f_2-f_1)] \times (p_2 - p_1) \quad \text{Equation 4-1a}$$

where:

f = a known flow value between  $f_1$  and  $f_2$

p = the unknown pressure drop value corresponding to f.

$p_1$  and  $p_2$  = known values that are less than and greater than p respectively.

$f_1$  and  $f_2$  are the known values corresponding to  $p_1$  and  $p_2$ .

$$f = f_1 + [(p-p_1) \div (p_2-p_1)] \times (f_2 - f_1) \quad \text{Equation 4-1b}$$

where:

p = a known pressure drop value between  $p_1$  and  $p_2$

f = the unknown flow value corresponding to p.

$f_1$  and  $f_2$  = known values that are less than and greater than f respectively.

$p_1$  and  $p_2$  are the known values corresponding to  $f_1$  and  $f_2$ .

See Example 4-1 for sample calculations that determine the rated airflow of the filter corresponding to a known pressure drop specification (0.1 inch w.c.).

**Figure 4-6. Plot of Pressure drop vs. Airflow for a 20" X 30" X 1" Depth Air Filter  
From Manufacturer Label Information**

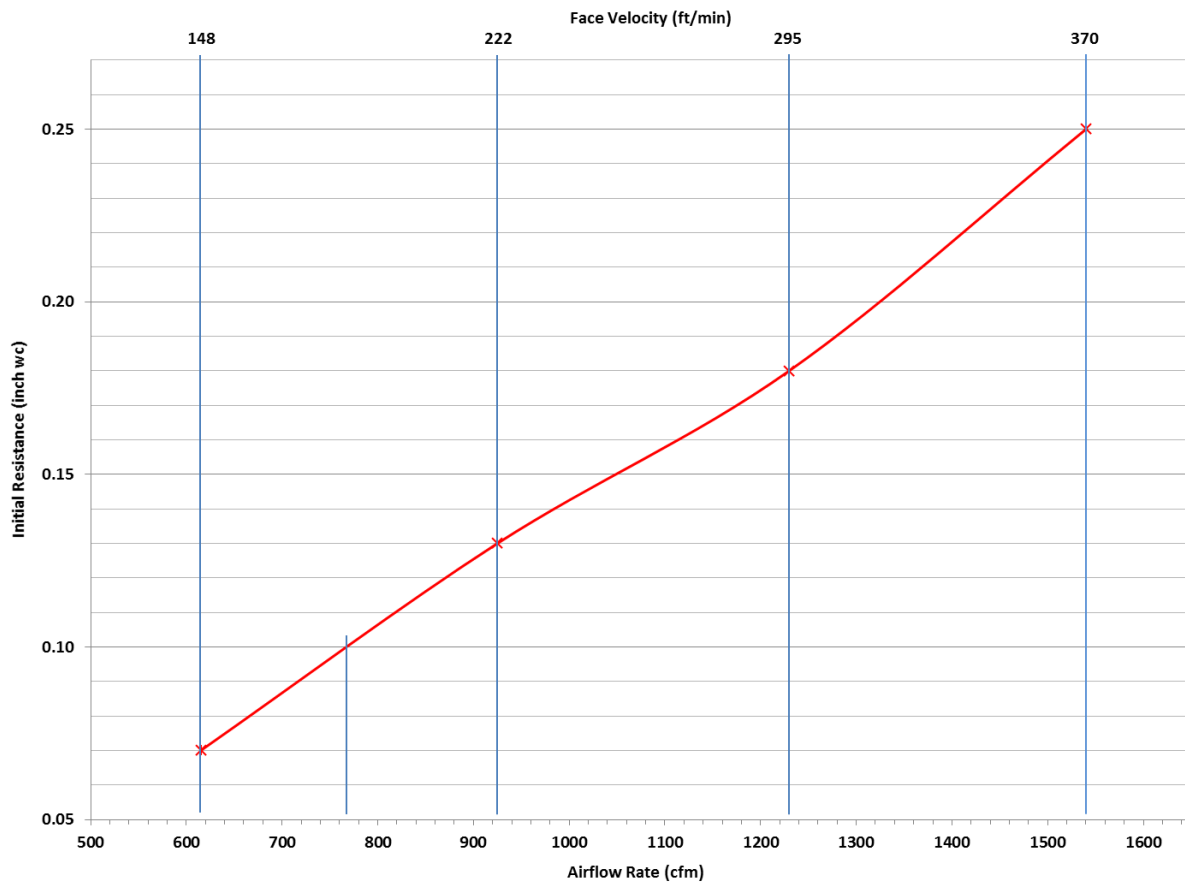

Source: California Energy Commission

#### Example 4-1– Filter Selection Using Linear Interpolation

##### Question:

Does the air filter label in Figure 4-5 indicate the filter would meet the airflow (750 CFM) and pressure drop (0.1 inch w.c) requirements shown on the installer filter grille sticker in Figure 4-4? How can I determine the filter's airflow rate at 0.1 inch w.c. for the manufacturer's filter label shown in Figure 4-5?

##### Answer:



The filter must be rated to provide greater than 750 CFM at the specified 0.1 inch w.c. pressure drop, or equivalently: the filter must be rated to provide a pressure drop less than 0.1 inch w.c at the specified 750 CFM.

Referring to Equation 4-1b, we calculate the unknown value " $f$ " in CFM that corresponds to the known value " $p$ " of 0.1 inch w.c..

Referring to Figure 4-5:  $p_1=0.07$ ,  $p_2=0.13$ ,  $f_1=615$ ,  $f_2=925$ , and applying Equation 4-1b:  $615 + [(0.1-0.07) \div (0.13-0.07)] \times (925-615)$  yields 770 CFM

Therefore, since the filter is rated for greater than 750 CFM at 0.1 inch w.c, the filter complies.

#### Example 4-2– Filter Sizing

**Question:**

I am installing a 1,200 CFM furnace in a new house. It has a 20" x 20" x 1" inch filter rack furnished with a 1" depth filter installed in the unit. Is this filter in compliance?

**Answer:**

The nominal face area of the filter rack is 20" x 20" = 400 in<sup>2</sup>, and since it is a 1" filter, the face area may not be less than 1,200 (CFM)/150x144 (in<sup>2</sup> / ft<sup>2</sup>) = 1,152 in<sup>2</sup>. Therefore, this filter installation does not comply.

#### Example 4-3

**Question:**

For the same 1,200 CFM furnace, what other options do I have?

**Answer:**

Option 1: The filter will comply if it has a depth of 2 inches or more and is properly sized by the system designer such that the duct system as a whole will be capable of meeting the HERS verification for fan efficacy specified in Section 150.0(m)13.

Otherwise, the required total system filter face area of 1,152 in<sup>2</sup> must be met using multiple remote wall or ceiling filter grilles for which the sum of the face areas are equal to or greater than 1152 in<sup>2</sup>, and the filters must be rated for pressure drop of 0.1 inch w.c. or less at the design airflow rates of each filter grille.

Option 2: Table 150.0-B may be used for compliance. If the air conditioner is rated at 3 tons and two return ducts sized at 16" and 14" or larger are provided, the total filter/grille nominal area may be reduced to 900 in<sup>2</sup>, or 450 in<sup>2</sup> per filter grille. However, the filters still must have a pressure drop of 0.1 inch or less at 600 CFM (based on filter manufacturer label data).

For any filter, the pressure drop, efficiency, and length of time the filter can remain in operation without becoming fully loaded with dust, can all be improved by using filters that are deeper than 1". As the depth of the filter is increased, the pressure drop across the filter at the same face area will be greatly reduced.

---

**Example 4-4****Question:**

I am installing a ductless split system in a space that is being added on to the house. Must I use the designated MERV 13 filter?

**Answer:**

No. The filtration requirements do not apply unless there is at least 10 feet of duct attached to the unit.

**Example 4-5****Question:**

My customer has allergies and wants a MERV 16 or better filter. Is this in compliance?

**Answer:**

Yes. MERV rated filtration greater than MERV 13 meets (exceeds) the minimum particle removal efficiency requirement; thus, it may be used provided all other applicable requirements in Section 150.0(m)12 are complied with.

**4.4.1.15 Forced-Air System Duct Sizing, Airflow Rate, and Fan Efficacy****§150.0(m)13**

Adequate airflow is critical for cooling equipment efficiency. Further, it is important to maintain adequate airflow without expending excessive fan power.

Section 150.0(m)13 requires system airflow and watt draw to be HERS-verified. See Reference Residential Appendices RA3.3 for the applicable HERS verification procedures.

Forced-air systems that provide cooling must comply with either the airflow rate and fan efficacy verification, or may comply with the return duct design specifications given in Tables 150.0-B and C.

**1. Airflow and watt draw measurement and determination of fan efficacy:**

When using the airflow (CFM/ton) and fan efficacy (watt/CFM) method, the following criteria must be met:

- a. Provide airflow through the return grilles that is equal to or greater than
  - 350 CFM per ton of nominal cooling capacity for systems that are not small-duct high-velocity systems.
  - 250 CFM per ton for small duct, high velocity systems.

Nominal cooling capacity. To determine the required airflow for compliance in CFM/ton, the nominal cooling capacity of the system in tons must be known.

The nominal cooling capacity system may be obtained from the manufacturer's product literature or from listings of certified product ratings from organizations such as AHRI, but the nominal capacity is usually shown in the unit model number on the manufacturer's nameplate attached to the outdoor condensing unit. A two- or three-digit section of the manufacturer's model number indicates the nominal capacity in thousands of BTU/hour. Given that there are 12,000 BTU/hour per ton of cooling capacity, you are likely to see something similar to one of the following number groupings in the model number: "018" which represents 1.5 Tons; "024," which represents 2 Tons; "030," which represents 2.5 Tons; "036," which represents 3 Tons; "042," which represents 3.5 Tons; "048," which represents 4 Tons; or "060," which represents 5 Tons.

- b. At the same time, the fan watt draw must be less than or equal to
- 0.45 watts per CFM for gas furnaces, or
  - 0.58 watts per CFM for air handling units that are not gas furnaces.
  - 0.62 watts per CFM for small duct, high velocity systems.

The methods for measuring the air-handling unit watt draw are described in Reference Residential Appendix RA3.3. Three acceptable apparatuses are:

- a. A portable watt meter,
- b. An analog utility revenue meter, or
- c. A digital utility revenue meter.

Note: When measuring fan watt draw in package air conditioners or heat pumps, it is recommended to use a portable true power clamp-on meter to provide flexibility for isolating the correct fan wires. These meters may need to be high-voltage-capable.

There are three acceptable methods for determining compliance with the system airflow requirement. They are described in Reference Residential Appendix RA3.3 and use one of the following:

- a. An active or passive flow capture hood to measure the total airflow through the return grill(s)
- b. Flow grid device(s) at the return grill(s) or other location where all the central fan airflow passes through the flow grid, or
- c. Fan flow meter device (also known as a duct blaster) to perform the plenum pressure matching procedure.

The flow grid and the fan flow meter methods both require access to static pressure measurements of the airflow exiting the cooling coil, which requires use of a HSPP or PSPP (Section RA3.3.1.1).

The contractor must install either a hole for the placement of a static pressure probe (HSPP) or provide a permanently installed static pressure probe (PSPP) as shown in Figure 4-5 below and Reference Residential Appendix RA3.3.

**Figure 4-5: Location of the Static Pressure Probe**

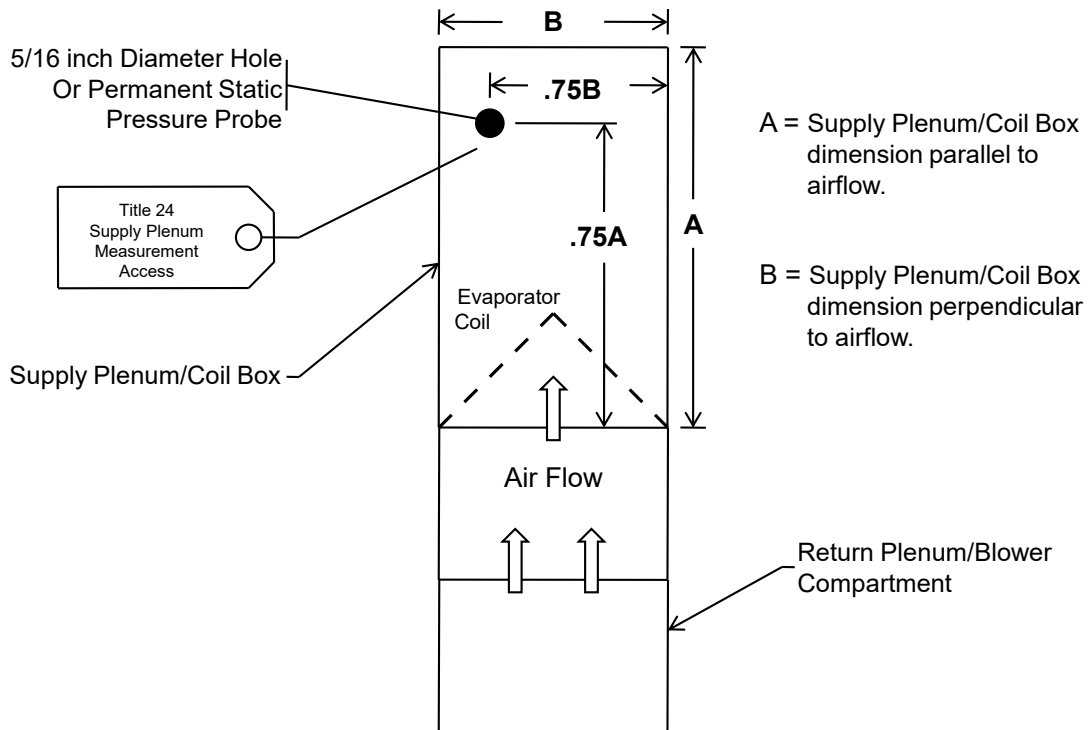

Source: California Energy Commission

The HSPP or PSPP simplifies cooling coil airflow measurement when using devices/procedures that depend on supply plenum pressure measurements.

2. Return Duct System Design Method – This method allows the designer to specify, and the contractor to install, a system that does not have to be tested for airflow and fan efficacy. This method can be used for systems with either one, or two return grilles. Each return shall not exceed 30 feet as measured from the return plenum to the filter grille. When bends are needed, sheet metal elbows are desirable. Each return can have up to 180 degrees of bend, and flex duct can have no more than 90 degrees of bend. To use this method, the designer and installer must provide return system sizing that meets the appropriate criteria in Standards Table 150.0-B and C, also shown in Table 4-10 or Table 4-11 below.

#### 4.4.1.16 Airflow and Fan Efficacy Testing Versus Return Duct Sizing

Studies have shown that adequate airflow is critical to the efficient operation of air-conditioning systems. Section 150.0(m)13B, 13C, and 13D establish mandatory requirements that are intended to ensure adequate cooling airflow through properly sized ducts and efficient fan motors.

There are two options allowed to ensure adequate air flow. The first option is to design and install the systems using standard design criteria and then have the airflow and fan efficacy (AF/FE) of the system tested and third-party verified in the field. The second option is to size the return ducts according to Table 4-10 and Table 4-11 (as specified by EXCEPTION 1 to §150.0(m)13B and D).

The California Green Code and the California Mechanical Code require that residential duct systems be designed according to ACCA Manual D, or equivalent. If reasonable care and judgment are used while designing the duct system (both return and supply ducts), and the system is designed to reasonable parameters for airflow per ton, static pressure across the fan, and friction rate, these systems should have no problem passing the diagnostic tests.

The following design guidelines will increase the chances of the system passing the AF/FE testing:

1. Right-size the HVAC system; if a 3-ton unit is enough to satisfy the cooling load, do not install a 4-ton unit “just to be safe.” Oversizing equipment can cause comfort problems in addition to excessive energy use.
2. The HVAC designer must coordinate closely with the architect and structural engineer to make sure that the ducts will fit into the home as designed.
3. Prepare a detailed mechanical plan that can be followed in the field. If deviations must occur in the field, make sure that they are coordinated with the designer and that the design is adjusted as needed.
4. Follow Manual D for duct sizing:
  - a. Make sure that the correct duct type is being used (vinyl flex, sheet metal, rigid fiberglass, or other).
  - b. Make sure that all equivalent lengths and pressure drops are correctly accounted for (bends, plenum start collars, t-wyes, filters, grilles, registers, and so forth).
  - c. Select a furnace that will provide at least 400 CFM/ton at the desired static pressure of 125 to 150 Pa (0.5 to 0.6 inches w.c.).
  - d. Design the duct system to a static pressure across the fan of no more than 150 Pa (0.6 inches w.c.).
  - e. Consider upsizing the evaporator coil relative to the condenser to reduce the static pressure drop. This upsizing results in better airflow and slightly

better capacity and efficiency. Manufacturers commonly provide performance data for such condenser coil combinations.

- f. Consider specifying an air handler with a high efficiency (brushless permanent magnet) fan motor.
5. Install a large grill area and use a proper filter for the system.
6. Locate registers and equipment to make duct runs as short as possible.
7. Make all short-radius 90-degree bends out of rigid ducting.
8. Install flex duct properly by stretching all flex duct tight and cut off excess ducting, ensure the duct is not kinked or compressed, ensure flex duct is properly supported every 4 feet or less using 1inch strapping having less than 2 inches of sag between supports.

Consider using better quality supply and filter grilles. “Bar-type” registers have considerably better airflow performance than standard “stamped-face” registers. Refer to the manufacturer’s specifications and select accordingly.

Energy Standards Tables 150.0-B and C (Table 4-10 and Table 4-11) allow for only one or two returns. There may be times where three returns are necessary on a single system. Furthermore, Table 150.0-C does not allow for deviation from the two sizes specified. For example, the table requires two 16-inch return ducts for a 3.5-ton system, but specific airflow requirements and architectural constraints may dictate something more like a 20-inch and a 14-inch. In this situation, the designers would have to rely on standard engineering principles and trust that their design will pass the AF/FE diagnostic tests.

Having adequate room to run properly sized ducts has always been an issue. Historically, duct systems have been sized to fit into the home at the expense of proper airflow. The performance of these systems, in terms of efficiency and capacity, has suffered greatly because of this practice. These standards intend to change these practices. The home should be designed to accommodate properly sized ducts. This requires improved coordination among the architect, structural engineer, and mechanical designer earlier in the process.

Tables 150.0-B and C require the use of return grilles that are sized to achieve an optimal face velocity and static pressure drop. Tables 150.0-B and C also require the return grille devices to be labeled in accordance with the requirements in §150.0(m)12A to disclose the design airflow rate of the grille, and the maximum allowable clean-filter pressure drop for the air filter media as determined by the system design or applicable standards requirements. The nominal size of the air filter grille or air filter media should be used to calculate the return filter grille gross area for determining compliance with Tables 150.0-B and C. The nominal size of the filter grille is expected to be the same as the nominal size of the air filter media that is used in the grille and is most often the information used to identify these items for purchases. For example, a nominal 20-inch x 30-inch filter grille will use nominal 20-inch x 30-inch air filter media.

#### 4.4.1.17 Return Duct Sizing Example

The mechanical contractor for a new home submitted the following mechanical design to the builder. It was designed using typical design specifications (400 CFM/ton at 125 Pa [0.5" w.c., friction rate = 0.1, etc.]). The system has a 4-ton condenser, and the air handler is rated for 1,600 CFM.

Figure 4-6: Return Duct Design Option 1

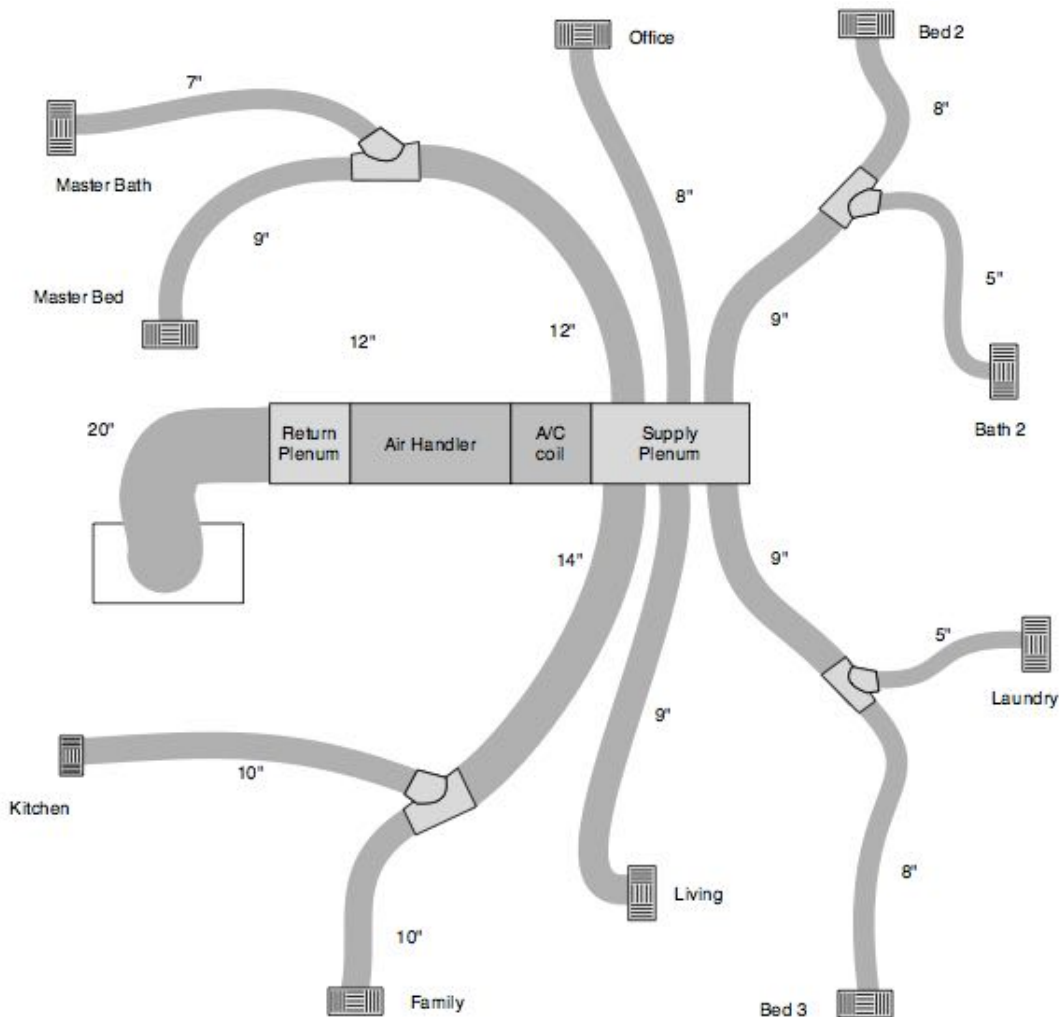

Source: California Energy Commission

Because the builder has specified a low-end air handler, he or she is concerned that the system may not pass the mandatory diagnostic testing requirement for airflow and fan efficacy. The builder requests that the system be redesigned with the return ducts sized according to Table 150.0-C. The following layout is the redesigned system (Figure 4-7). The only change is that the system now has two 18-inch return ducts and two filter grilles sized according to Table 150.0-C, rather than a 20-inch return duct and a filter grille. Because one of the return ducts had more than one 90-degree bend, one of the bends is required to be a metal elbow (to be insulated). The



two return filters are 20-inch x 30-inch each and are rated by the manufacturer to show that they have a pressure drop of less than 125 Pa (0.1" w.c.) at 800 CFM each.

**Figure 4-7: Return Duct Design Option 2**

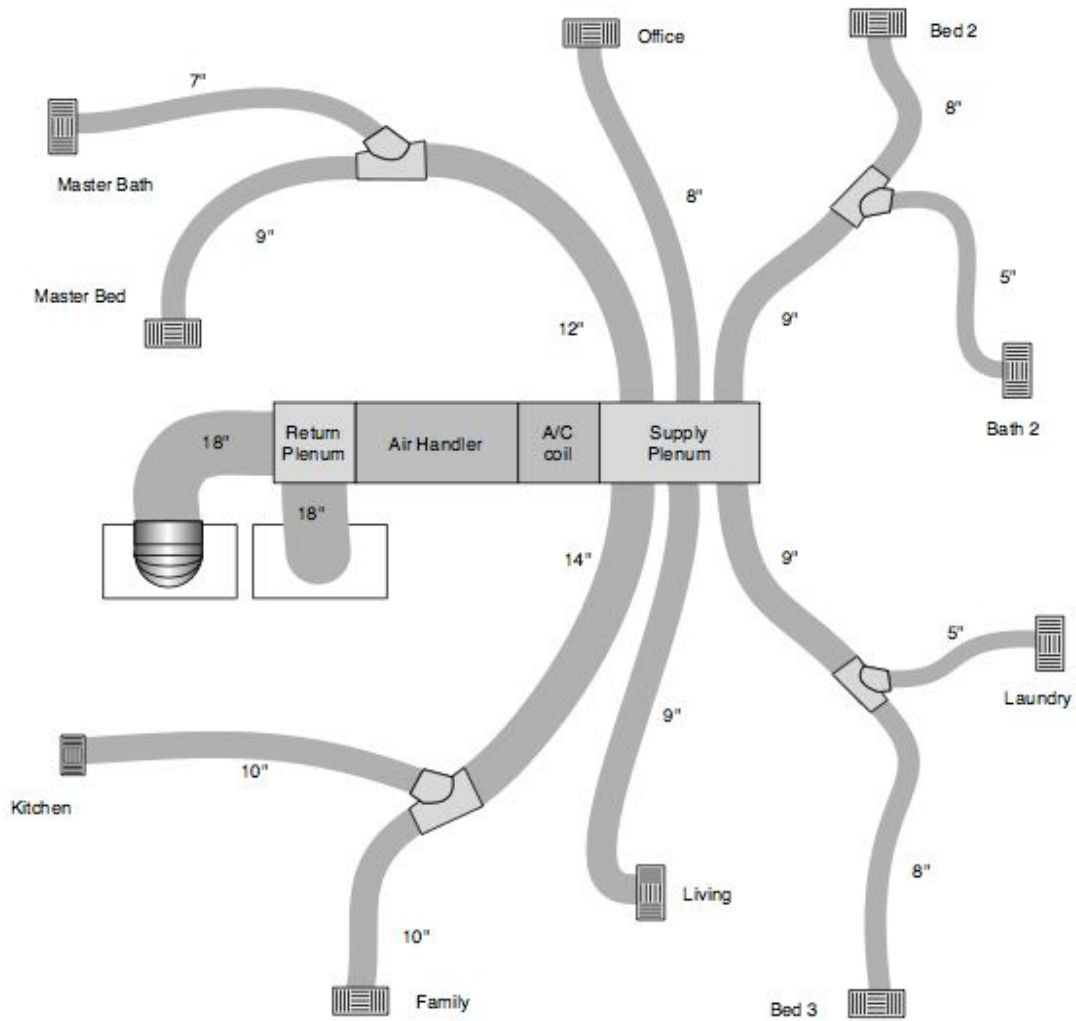

Source: California Energy Commission

**Table 4-10: Return Duct Sizing for Single Return Duct Systems**

System Nominal Cooling Capacity (Ton)	Minimum Return Duct Diameter (inch)	Minimum Total Return Filter Grille Gross Area (Inch <sup>2</sup> )
1.5	16	500
2.0	18	600
2.5	20	800

From Table 150-B of the Energy Standards

**Table 4-11: Return Duct Sizing for Multiple Return Duct Systems**

**Two Returns**

System Nominal Cooling Capacity (Ton)	Return Duct 1 Minimum Diameter (inch)	Return Duct 2 Minimum Diameter (inch)	Minimum Total Return Filter Grille Gross Area (inch <sup>2</sup> .)
1.5	12	10	500
2.0	14	12	600
2.5	14	14	800
3.0	16	14	900
3.5	16	16	1000
4.0	18	18	1200
5.0	20	20	1500

From Table 150-C of the Energy Standards

**4.4.1.18 Zonally Controlled Central Forced-Air Cooling Systems**

The primary purpose of zoning ducted air conditioners, heat pumps, and furnaces is to improve comfort. Increased comfort is attained by having the capacity of the HVAC system (cooling or heating delivered) follow the shift in load as it changes across the house. For example, it is common for two-story homes to be too hot on the second floor in summer and winter. Zoning has the capability of diverting more of the HVAC capacity to the area with the increased load. Another common example is a home with a significant area of west-facing and east-facing windows. In the summer, the east rooms overheat in the morning, and the west rooms overheat in the afternoon.

Providing the most agreeable temperature to all the zones is comfortable, but it carries with it the possibility of increased energy consumption. Since the most common home is single-zoned and has only one thermostat placed near the center of the house, temperatures in the rooms distant from that thermostat will vary, sometimes significantly. If zoning is added, the more distant rooms may be conditioned to a more comfortable temperature. This increased conditioning requires more energy. When designed correctly, zoning allows only the zones that need conditioning to be conditioned, thus potentially saving energy.

It is common for single-speed zonally controlled central forced-air cooling systems to produce lower total system airflow through the returns when fewer than all zones are

calling for conditioning. The reduced airflow lowers the sensible efficiency of single-stage heating or cooling equipment. Two primary causes of lower airflow in multiple zone dampered systems are:

1. Restriction of some system supply ducts by closing zoning dampers in zones that do not need additional cooling, while other zones do need cooling.
2. Recirculation of already-cooled air from the supply plenum directly back to the return plenum without first delivering the cooled air to the conditioned space by use of a bypass duct.

To prevent the lower efficiency that results from reduced system airflow or from recirculated bypass duct airflow, single-speed compressor zonally controlled central cooling systems must demonstrate they simultaneously meet mandatory fan efficacy and airflow requirements in all zonal control modes, which is possible only with a superior duct system design that does not restrict the system total airflow when fewer than all zones are calling for conditioning, and does not use a bypass duct. Section 150.1(c)13 prohibits use of bypass ducts prescriptively, but bypass ducts may be used if the efficiency penalty due to the reduced airflow through the return grille is modeled as described in Section 4.4.1.19 below.

Multispeed or variable-speed compressor-type zonally controlled cooling systems are not required to verify mandatory fan efficacy and airflow requirements in all zonal control modes; however, these systems must be HERS-verified to confirm they meet the mandatory fan efficacy and airflow requirements with the compressor on high speed and all zones calling for cooling.

#### **4.4.1.19 Zonally Controlled Cooling Systems – Airflow and Fan Efficacy Requirements**

Recent studies have shown that zonally controlled cooling systems with or without bypass dampers (multiple zones served by a single air handler with motorized zone dampers), usually do not meet the airflow and fan efficacy (AF/FE) requirements when fewer than all zones are calling. The energy penalty that results from this is greater than the benefit of having zonal control; therefore, zonal control is no longer simply assumed to be a “better-than-minimum” condition, and there are special compliance requirements for these systems.

Zonal control accomplished by using multiple single-zone systems is not subject to the requirements specified in Energy Standards Section 150.0(m)13C.

Two-speed and variable-speed compressors are considered multi-speed. Multispeed compressors allow the system capacity to vary to more closely match reduced cooling loads when fewer than all zones call for cooling. Therefore, an exception to Section 150.0(m)13C gives multispeed compressor systems special consideration when used in zoned systems and these systems are not required to verify performance in all zonal control modes. Instead, the airflow and fan efficacy testing is required to be performed only at the highest speed when all zones call for cooling. Zoned systems with single-speed compressors must be tested and pass in all operating modes.

An exception to Section 150.0(m)13C allows single-speed compressor systems to comply with HERS verification of the *mandatory* AF/FE requirements only at the highest fan speed when all zones call for cooling. The exception applies provided the system also uses the *performance* compliance approach and complies with HERS verification of the requirements for AF/FE in all zonal control modes specified by the software user input for minimum airflow rate when fewer than all zones call for cooling. Single-speed compressor systems, with or without bypass dampers, are less likely to meet the *mandatory* AF/FE requirements in Section 150.0(m)13C with fewer than all zones calling for cooling. Therefore, the performance compliance software calculates a penalty for the reduced airflow (specified by the user) during operation when fewer than all zones call for cooling. Other energy features for the building must offset this penalty for reduced airflow when fewer than all zones call for cooling. In the performance compliance software, if the system is modeled as a zoned system with a single-speed compressor, the minimum allowable airflow drops to 150 CFM/ton. But because the standard house is assumed to have an airflow of 350 CFM/ton, there is a penalty imposed on the compliance calculation unless the designer specifies a value of 350 or higher. Entering a value between 150 and 350 can lessen the penalty resulting from the minimum allowed value of 150 CFM/ton.

It is extremely important that the energy consultant model airflow and fan efficacy values that are reasonable and can be verified by a HERS Rater; otherwise, the system will fail HERS verification, and the compliance calculations will have to be revised to specify user input equivalent to the actual values that could pass HERS verification. Energy consultants should coordinate with the HVAC designer before registering the certificate of compliance.

Bypass dampers may be installed only if the certificate of compliance specifically states that the system was modeled as having a bypass damper.

Example:

1. A home is to be built with a heat pump connected to a zoned system (two zones) with a single-speed compressor and bypass ducts. From experience, the HVAC contractor knows that it will not be possible to meet the 350 CFM/ton requirement, but 275 CFM/ton is likely.
2. The energy consultant models the system in the proposed house with 275 CFM/ton and 0.45 W/CFM (value for a gas furnace). Because the standard house assumes 350 CFM/ton, there is an energy penalty that must be made up by including other better-than-standard features in the performance compliance input, but the penalty is not as large as it would be at a value of 150 CFM/ton.
3. 275 CFM/ton must be tested in all control modes.
4. The home is built, and the system is verified by a rater and passes at 287 CFM/ton with one zone calling, 298 CFM/ton with the other zone calling, and 372 CFM/ton with both zones calling. The system is also measured with all zones calling to confirm it meets or exceeds 350 CFM/ton.

5. If this same home was to be built with a multispeed compressor, it would be tested only with all zones calling, but the target airflow would be no less than the mandatory 350 CFM/ton. Compliance credit can be achieved by modeling airflows greater than the mandatory CFM/ton and/or fan efficacies less than the mandatory watts/CFM.

**Table 4-12: Single-Zone Ducted Central Forced-Air Cooling Systems**

Single-Zone Ducted Cooling Systems (Single Zone Off a Single Air Handler)

Compressor Type	Mandatory Requirements for Airflow and Fan Efficacy	Performance Compliance Option Proposed System Defaults	Performance Compliance Option Modeled Airflow and Fan Efficacy
Single-Speed, Multispeed, or Variable-Speed:  Testing Performed on Highest Speed only	Airflow: <ul style="list-style-type: none"> <li>• ≥ 350 CFM/ton if not a small duct high velocity type</li> <li>• ≥ 250 CFM/ton if is a small duct high velocity (SDHV) type</li> </ul> Fan Efficacy: <ul style="list-style-type: none"> <li>• ≤ 0.45 W/CFM for gas furnaces (GF)</li> <li>• ≤ 0.58 W/CFM for air handlers that are not gas furnaces (non-GF)</li> <li>• ≤ 0.62 W/CFM for SDHV type</li> </ul> Exception: Airflow and Fan Efficacy HERS verification not required if return system meets Tables 150.0-B or C. However, HERS verification that return duct installation meets Tables 150.0-B or C is required	Airflow: <ul style="list-style-type: none"> <li>• 350 CFM/ton (non-SDHV)</li> <li>• 250 CFM/ton (SDHV)</li> </ul> Fan Efficacy: <ul style="list-style-type: none"> <li>• 0.45 W/CFM (GF)</li> <li>• 0.58 W/CFM (non-GF)</li> <li>• 0.62 W/CFM (SDHV)</li> </ul>	Airflow: <ul style="list-style-type: none"> <li>• ≥350 CFM/ton (non-SDHV)</li> <li>• ≥250 CFM/ton (SDHV)</li> </ul> and/or                     Fan Efficacy: <ul style="list-style-type: none"> <li>• ≤0.45 W/CFM (GF)</li> <li>• ≤0.58 W/CFM (non GF)</li> <li>• ≤0.62 W/CFM (SDHV)</li> </ul>

Source: California Energy Commission

**Table 4-13: Zonally Controlled Central Forced-Air Cooling Systems**

Zoned Ducted Cooling Systems (Multiple Zones off a Single Air Handler)

Compressor Type	Mandatory Requirements for Airflow and Fan Efficacy <sup>1</sup>	Performance Compliance <sup>2</sup> Proposed System Defaults <sup>3</sup>	oned Ducted Cooling Systems (Multiple Zones off a Single Air Handler) Modeled Airflow and Fan Efficacy
<b>Single Speed</b>	Airflow: <ul style="list-style-type: none"> <li>• ≥ 350 CFM/ton (non-SDHV)</li> </ul> Fan Efficacy: <ul style="list-style-type: none"> <li>• ≤ 0.45 W/CFM (GF)</li> <li>• ≤ 0.58 W/CFM (non-GF)</li> </ul>	Airflow: <ul style="list-style-type: none"> <li>• 150 CFM/ton</li> </ul> Fan Efficacy: <ul style="list-style-type: none"> <li>• 0.45 W/CFM (GF)</li> </ul>	Airflow: <ul style="list-style-type: none"> <li>• ≥ 150 CFM/ton</li> </ul> and/or                     Fan Efficacy:

Compressor Type	Mandatory Requirements for Airflow and Fan Efficacy <sup>1</sup>	Performance Compliance <sup>2</sup> Proposed System Defaults <sup>3</sup>	oned Ducted Cooling Systems (Multiple Zones off a Single Air Handler) Modeled Airflow and Fan Efficacy
	<p>For Prescriptive Compliance Method, verification is mandatory in all zonal control modes.</p> <p>When Performance Compliance Method is used, verification of the <i>mandatory</i> requirements are performed only at highest capacity operation with all zones calling, and the additional performance targets for W/CFM and CFM/ton specified by the user in the performance compliance software are required to be verified in all zonal control modes.</p>	<ul style="list-style-type: none"> <li>0.58 W/CFM (non-GF)</li> </ul>	<ul style="list-style-type: none"> <li>≤ 0.45 W/CFM (GF)</li> <li>≤ 0.58 W/CFM (non GF)</li> </ul> <p>Verification of modeled values required in all zonal control modes.</p> <p>The <i>mandatory</i> requirements for W/cfm and CFM/ton must also be verified at highest capacity operation with all zones calling</p>
<p><b>Multispeed or Variable Speed</b></p>	<p>Airflow:</p> <ul style="list-style-type: none"> <li>≥ 350 CFM/ton</li> </ul> <p>Fan Efficacy:</p> <ul style="list-style-type: none"> <li>≤ 0.45 W/CFM (GF)</li> <li>≤ 0.58 W/CFM (non-GF)</li> </ul> <p>Verification is required at highest capacity operation and with all zones calling</p>	<p>Airflow:</p> <ul style="list-style-type: none"> <li>350 CFM/ton</li> </ul> <p>Fan Efficacy:</p> <ul style="list-style-type: none"> <li>0.45 W/CFM (GF)</li> <li>0.58 W/CFM (non-GF)</li> </ul>	<p>Airflow</p> <p>≥ 350 CFM/ton and/or</p> <p>Fan Efficacy:</p> <ul style="list-style-type: none"> <li>≤ 0.45 W/CFM (GF)</li> <li>≤ 0.58 W/CFM (non-GF)</li> </ul> <p>Verification of modeled values required at highest capacity operation with all zones calling</p>

<sup>1</sup> For the Prescriptive Compliance Method, all Mandatory Requirements for airflow and fan efficacy must be met and use of a bypass duct is not allowed.

<sup>2</sup> For the Performance Compliance Method, all Mandatory Requirements for airflow and fan efficacy must be met and use of a bypass duct may be specified in the compliance software input for the zoned system type. Additionally, the requirements specified for performance compliance must be met

<sup>3</sup> The Standard Design value for all cases is 350 CFM/ton (all system types); 0.45 W/CFM (GF); 0.58 W/CFM (non-GF).

Source: California Energy Commission

**4.4.1.20 Indoor Air Quality and Mechanical Ventilation**

§150.0(o)

See Section 4.6 of this chapter for details.

### 4.4.2 Prescriptive Requirements for Air Distribution System Ducts, Plenums, and Fans

The *2019 Energy Standards* are designed to offer flexibility to the builders and designers of residential new construction in terms of achieving the intended energy efficiency targets. As such, several options are offered for achieving one of two design objectives related to improving energy performance of homes built with ventilated attics in Climate Zones 4, and 8-16, as shown in Figure 4-8.

**Figure 4-8: Ventilating Attic Prescriptive Compliance Choices in Climate Zones 4, 8-16**

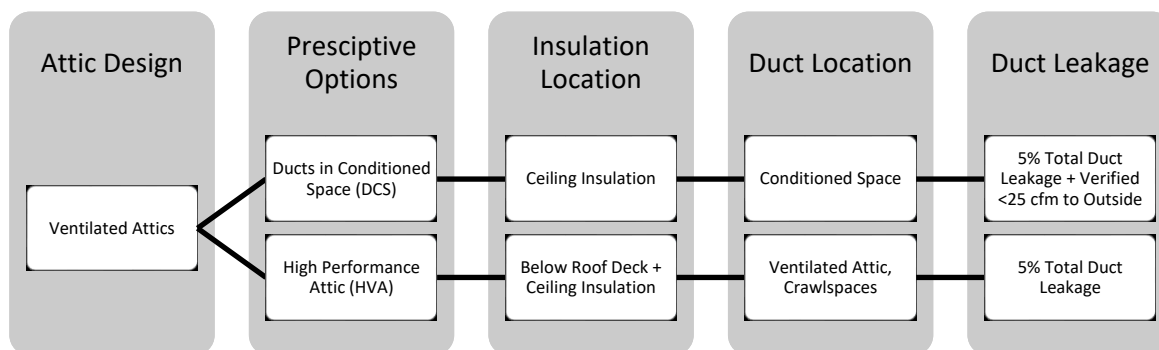

Source: California Energy Commission

A high-performance attic (HPA) implements measures that minimize temperature difference between the attic space and the conditioned air being transported through ductwork in the attic. The package consists of insulation below the roof in addition to insulation at the ceiling, R-8 ducts, and 5 percent total duct leakage of the nominal air handler airflow. These requirements and approaches to meet the requirements are explained in Section 3.5.3 of this manual.

Ducts in conditioned space (DCS) is achieved when the ducts and air handler(s) are within the thermal envelope and air barrier of the building. This DCS option requires field verification to meet the prescriptive requirement. The following sections describe the duct related requirements for DCS.

#### 4.4.2.1 Duct Location

§150.1(c)9

Standard residential construction practice in California is to place ducts and associated air handling equipment in the attic. When meeting the prescriptive requirements for the Energy Standards, there are two options for where this equipment can be located:

1. If meeting the prescriptive requirements of the high-performance attic (HPA) as explained above, the duct system and air handlers of HVAC systems are allowed to be located in the attic.

2. If meeting the prescriptive requirements of the ducts in conditioned space (DCS) as explained above, the duct system and air handlers of HVAC systems must be located in conditioned space, which includes a joist cavity between conditioned floors, or in a sealed cavity below attic insulation.

If the DCS requirements are to be met, additional requirements apply:

1. Air handlers containing a combustion component should be direct-vent (sealed combustion chambers) and shall not use air from conditioned space as combustion air. Other types of combustion heating systems are possible given the system installer adheres to the combustion air requirements found in Chapter 7 of the California Mechanical Code.
2. Duct location needs to be verified through a visual inspection per Reference Residential Appendix RA 3.1.4.1.3.
3. Duct leakage to outside needs to be confirmed by field verification and diagnostic testing in accordance with Reference Residential Appendix RA3.1.4.3.8.
4. Ducts are insulated to a level required in Table 150.1-A.

**Figure 4-9: Checklist for Prescriptive Requirement – Option C DCS (§ 150.1(c)1)**

<p><b>§150.1(c)1</b> <b>Option C</b></p>
<ul style="list-style-type: none"> <li><input type="checkbox"/> Vented attic</li> <li><input type="checkbox"/> R30 or R38 ceiling insulation (climate zone specific)</li> <li><input type="checkbox"/> R6 ducts (climate zone specific)</li> <li><input type="checkbox"/> Radiant Barrier</li> <li><input type="checkbox"/> Verified ducts in conditioned space</li> </ul>

Source: California Energy Commission

The checklist in Figure 4-9 lists all the requirements for complying prescriptively using DCS strategy. It is not enough to locate ducts in conditioned space, the insulation must also meet prescriptive values. If a building is not able to meet all of the requirements in this checklist, it must use the performance approach or Option B from Section 150.1(c).1. Refer to Section 3.5 of the *Residential Compliance Manual* for more information on these options.

There are several methods of achieving the goal of DCS. The basic information of the strategies, related benefits, challenges, and potential solutions to those challenges are outlined below.

#### **A. Vented Attic, Dropped Ceiling**

This strategy places ducts within the thermal envelope without affecting the standard construction of the attic space. This strategy works well in linear plans where rooms branch out from a central hallway with the dropped ceiling.



**Figure 4-10: Ducts in Conditioned Space Using a Dropped Ceiling**

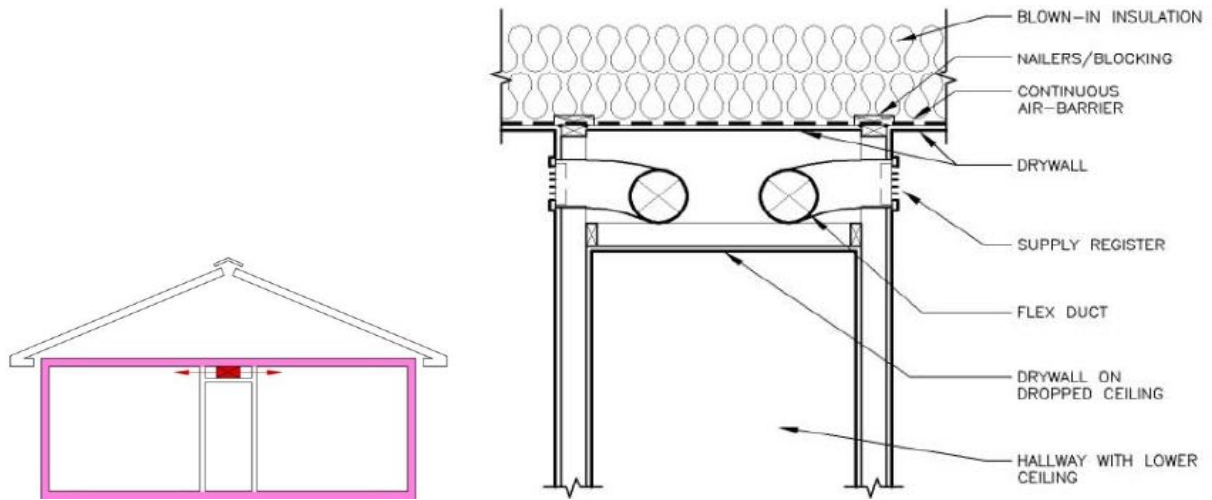

Source: [www.ductsinside.org/](http://www.ductsinside.org/)

**Figure 4-11: Ducts Routed Through a Dropped Ceiling**



Source: BIRA Energy

Benefits of selecting this strategy include the following:

1. Attic ventilation remains the same as standard practice.

2. This strategy does not affect attic assembly or insulation; there are no changes to truss design.
3. The strategy works with simple and linear designs with rooms off the main hallway but can work with more complex plans.
4. The strategy can be integrated into architectural accents.

There are challenges associated with this strategy as outlined below, but they can be overcome with good design and installation practices.

1. Need to address air handler location – there may not be sufficient space (height, width) in the dropped ceiling to accommodate the air handler. In this case, the air handler would need to be installed in a separate closet within the thermal boundary of the home.
2. Coordination needed between trades – moving the ducts and air handlers and the need to isolate and seal the dropped ceiling would necessitate coordination between different trades (HVAC installer, drywall, framing, and electrical contractors) to ensure thermal integrity of the dropped ceiling.

### B. Vented Attic, Conditioned Plenum Space

A conditioned plenum is created when a space within the attic is sealed off and insulated from the rest of the attic. To use this design option, a builder can specify two types of modified trusses: either scissor trusses or a truss configuration that creates a plenum box. Another way to create a conditioned plenum does not involve modified trusses, but rather to create the space by framing, sealing and insulating the plenum space above the ceiling plane.

**Figure 4-12: Plenum Truss Design Example**

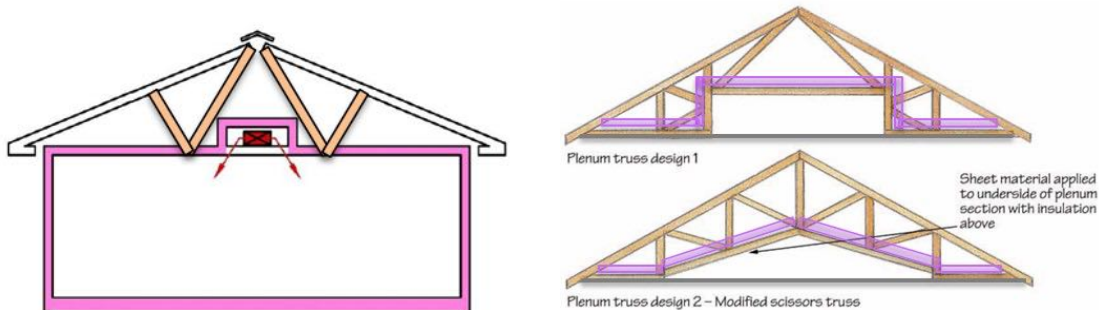

Source: [www.ductsinside.org](http://www.ductsinside.org)

Similar to a dropped ceiling, this design is easier with a linear plan that allows the conditioned space in the attic to cover a central “spine” throughout the floor plan that can reach all spaces in need of supply registers. This design option allows for ducts in the attic space and does not affect aesthetics of the home.

Benefits for selecting the strategy:

1. Vented attic space, same as standard construction

2. Aesthetically less disruptive than dropped ceiling
3. Works with simple and linear designs with rooms off main hallway

There are challenges associated with this strategy as outlined below, but they can be overcome with good design and installation practices.

1. Need to seal the plenum from attic – as with most of the DCS strategies, it is important that care and attention are provided to air-sealing the plenum space from the attic space.
2. May require modified trusses, in which case manufacturers need to be provided with specifications that can be met.

### C. Vented Attic, Open Web Floor Truss

Figure 4-13: Open Web Floor Truss Example



Source: [www.ductsinside.org](http://www.ductsinside.org)

This option can work for two-story construction and makes use of the space between floors to house ducts. Open-web floor trusses are uncommon in residential construction but are available from several floor joist manufacturers. The depth of floor joists may need to be increased to create a large enough space for supply ducts. The increased joist depth may affect interior details and wall heights. Because of the size constraints from using the floor truss, there is a need to preserve construction quality and prevent undesirable construction practices such as forcing 14-inch ducts into 12-inch joist spaces. Another option is to use alternatives to wire helix plastic flexible ducts that take up less space. Coordination between the architect and the HVAC engineer and/or contractor is needed to ensure that ducts are correctly sized and truss depths are appropriately selected. Using the area between floors to house ducts prescribes that supply registers be at the floor or lower wall in the second story and the ceiling or upper wall in the first story.

### D. Mechanical Closet and Placement of Sealed Combustion Furnace

**Figure 4-14: Mechanical Closet Placement Example**



Source: IBACOS 2013

As part of the requirement for moving the duct system and air handler into a conditioned space, construction of a mechanical closet is necessary with some DCS strategies. For example, if ducts are placed in dropped ceiling space but there is not enough room to accommodate the air handler in that space, the mechanical closet could be placed inside the thermal boundary of the building. A conditioned plenum could provide enough space for ducts and equipment; therefore, a mechanical closet may not be needed.

One potential location for a mechanical closet is within the garage or other spaces normally not conditioned. In such instances, the air handler must be located within a specially built closet that is insulated to the same level as the exterior of the house so that the closet is not a part of the unconditioned space. Combustion air for the air handler must be taken directly from the outside through a direct vent to the outside.

#### 4.4.2.2 Duct Insulation

**§150.1(c)9**

All ducts shall be insulated to a minimum installed level as specified by Table 150.1-A, which requires either R-6 or R-8 depending on the climate zone and whether Option B or Option C is chosen for roof/ceiling Insulation. Since R-6 is the mandatory minimum for ducts in unconditioned space and R-4.2 for ducts located entirely in conditioned space as verified by a HERS Rater, the prescriptive duct insulation requirement can be opted out by using the performance approach and trading off the energy penalty against some other features.

#### 4.4.2.3 Central Fan-Integrated (CFI) Ventilation

There is a prescriptive requirement for ducted systems that have cooling and a CFI ventilation system to have the fan efficacy verified. This can be opted out using the performance approach.

Figure 4-15: R-4.2, R-6, and R-8 Ducts

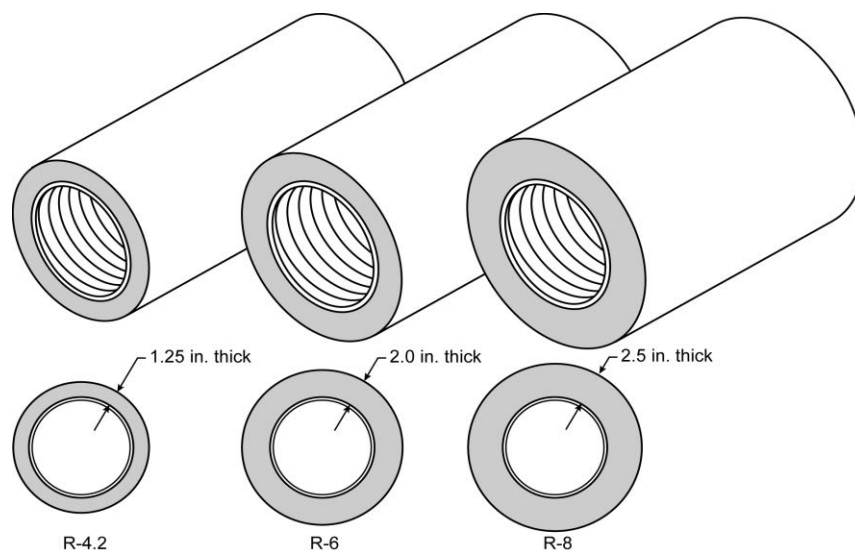

Source: California Energy Commission

#### 4.4.3 Compliance Options for Air Distribution System Ducts, Plenums, and Fans

The Energy Standards provide credit for several compliance options related to duct design and construction.

##### 4.4.3.1 System Airflow and Fan Efficacy

A performance compliance credit is available for HERS verification of the installation of a high-efficiency air handler and duct system that performs better than the applicable mandatory requirements for minimum system airflow (CFM/ton) and maximum system fan efficacy (W/CFM). The performance compliance method allows the user's proposed airflow and fan efficacy to be entered into the program, and credit will be earned if the airflow is greater than the minimum required, and fan efficacy is lower than the default. After installation, the contractor must test the actual fan efficacy of each system using the procedure in *Reference Residential Appendix RA3.3* and show that it is equal or less than what was proposed in the compliance software analysis.

The fan efficacy and airflow must also be verified by a HERS Rater.

##### 4.4.3.2 Duct Location

There are three ways to achieve credit for favorable duct location when using the performance compliance method:

1. Credit is available if no more than 12 linear feet (LF) of duct are outside the conditioned space and the user chooses the high-performance attic (HPA) as explained in Section 3.5.3. This total must include the air handler and plenum lengths. This credit results in a reduction of duct surface area in the computer compliance programs. This option requires certification by the installer and field verification by a HERS Rater.
2. The second alternative applies when 100 percent of the ducts are located in conditioned space and the user chooses high-performance attic (HPA) as explained in Section 3.5.3. This credit results in eliminating the conduction losses associated with the return and supply ducts; however, leakage rates still apply. This option requires field verification of the duct system by means of a visual inspection by a HERS Rater.
3. Credit for a high-efficiency duct design is available. This option requires field verification of the duct design layout drawing(s) by a HERS rater. Verified duct design, when required, will be included in the HERS Required Verification list on the certificate of compliance (CF-1R). This approach provides energy savings credits for having shorter duct runs, fewer ducts, ducts in beneficial locations of ductwork, and other benefits of a well-designed duct system. This credit is available regardless of whether a high-performance attic (HPA) or ducts in conditioned space (DCS) option is chosen, as explained in Section 3.5.3.

There is no compliance credit provided for choosing a heating system such as a wall furnace, floor heater, or room heater, even though those systems typically have no ducts. For these cases, the standard design in the compliance calculation uses the same type of system and has no ducts. However, other systems, such as hydronic heating systems with a central heater or boiler and multiple terminal units, are considered central HVAC systems that are compared to a ducted system in the standard design. If the hydronic system has no ducts, there may be a significant energy credit through the performance method.

#### 4.4.3.3 Duct Insulation

Performance credit is also available if all the ducts are insulated to a level higher than required by the prescriptive package. If ducts with multiple R-values are installed, the lowest duct R-value must be used for the entire duct system. However, the air handler, plenum, connectors, and boots can be insulated to the mandatory minimum R-value.

As an alternative when there is a mix of duct insulation R-values, credit is available through the method described in the next section.

#### 4.4.3.4 Diagnostic Duct Location, Surface Area, and R-value

This compliance option allows the designer to take credit for a high-efficiency duct design that incorporates duct system features that may not meet the criteria for the duct location and/or insulation compliance options described above. This method

requires that the designer must enter the design characteristics of all ducts that are not within the conditioned space. The information required for the input to the compliance software includes the length, diameter, insulation R-value, and location of all ducts. This method will result in a credit if the proposed duct system is better than the standard design.

To claim this credit, the duct system design must be documented on plans that are submitted to the enforcement agency and posted at the construction site for use by the installers, the enforcement agency field inspector, and the HERS Rater. The duct system must be installed in accordance with the approved duct system plans, and the duct system installation must be certified by the installer on the CF2R form and verified by a HERS Rater on the CF3R form. Details of this compliance option are described in the *Residential ACM Reference Manual*, and verification procedures are described in RA3.1 of the Reference Residential Appendix.

#### 4.4.3.5 Buried and Deeply Buried Ducts

This compliance option allows credit for the special case of ducts that are buried by blown attic insulation. For ducts that are within 3.5 inches of the ceiling, the effective R-value is calculated based on the duct size and R-value, depth of ceiling insulation, and type of blown insulation (fiberglass or cellulose) as shown in Tables 16, 17, and 18 in the *Residential ACM Reference Manual*. The user-entered duct system can be any combination of unburied, buried, and deeply buried duct runs. The software will determine the overall duct system effective R-value by weight averaging the user entered duct system.

Ducts must have a minimum insulation level prior to burial, R-6 for new ducts and R-4.2 for existing. This case is referred to as “Buried Ducts on the Ceiling.” Additional credit is available for “Deeply Buried Ducts,” which, in addition to the requirements for “Buried Ducts on the Ceiling,” are ducts completely covered by at least 3.5 inches of attic insulation. Deeply buried ducts must be enclosed in a lowered portion of the ceiling or buried by use of a durable containment system (e.g. gypsum board, plywood, etc.), or buried under a uniform level of insulation that achieves the 3.5-inch burial level.

Figure 4-16: Buried Ducts on Ceiling and Deeply Buried Ducts

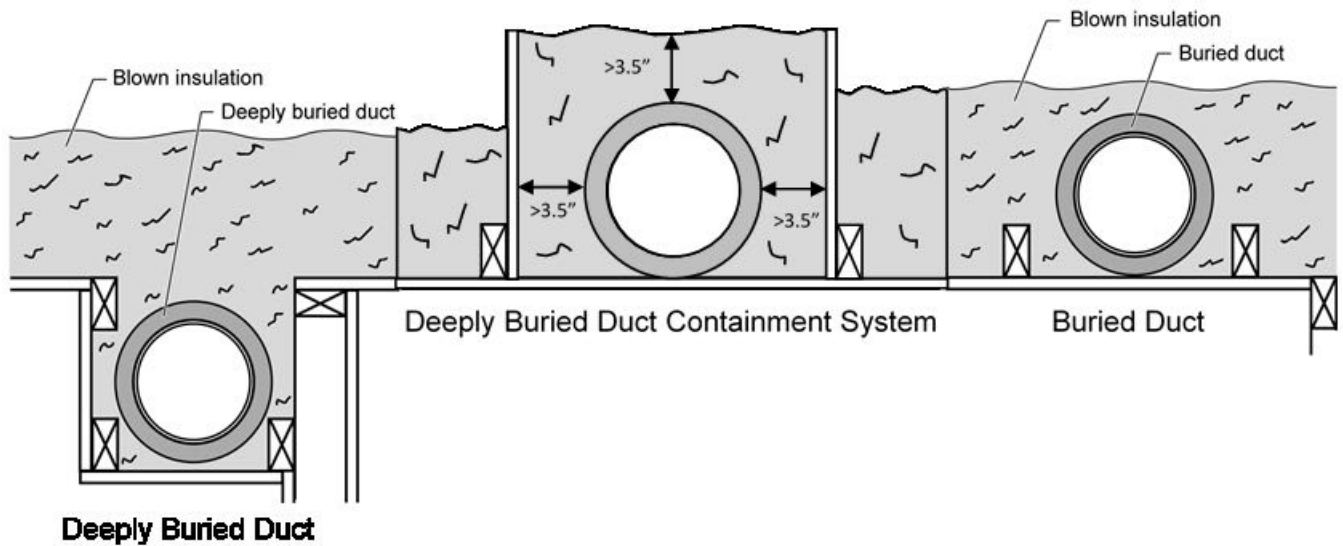

Source: California Energy Commission

Deeply buried containment systems must be installed such that the walls of the system are at least 7 inches wider than the duct diameter (3.5-inch clearance on each side of duct) extend at least 3.5 inches above the duct outer jacket, and the containment area surrounding the duct must be completely filled with blown insulation.

In addition to the above requirements, the attic area containing the buried or deeply buried ducts must have insulation with uniform depth (not mounded over the duct), level ceiling, and at least 6 inches of space between the duct outer jacket and the roof sheathing. Insulation raised by a containment system is an exception to the uniform depth requirement.

To take credit for buried ducts, the system must meet the verified duct system design criteria described above and meet the requirements for Quality Insulation Installation (QII) described in Reference Appendices RA3.5.

#### 4.4.3.6 Ducts in Attics with Radiant Barriers

Installation of a radiant barrier in the attic increases the duct efficiency by lowering attic summer temperatures. Compliance credit for radiant barriers is available in cases where the prescriptive standard does not require radiant barriers and requires listing of the radiant barrier in the special features and modeling assumptions to aid the local enforcement agency's inspections. Compliance credit for a radiant barrier does not require HERS Rater verification.

Radiant barrier must be installed with the appropriate clearance and/or air gap as specified by the manufacturer. Insulation products installed in direct contact with the radiant barrier may negatively affect the performance of the radiant barrier. When a



credit is taken for radiant barrier, an improperly installed radiant barrier assembly will require revision of the CF1R compliance document to remove the energy compliance credit taken.

**4.4.4 Duct Installation Standards**

The mandatory duct construction measures referenced in Section 4.4.1 above state that duct installations must comply with the California Mechanical Code Sections 601, 602, 603, 604, 605, and the applicable requirements of the Energy Standards. Some highlights of these requirements are listed in this section, along with some guidance for recommended quality construction practice.

**4.4.4.1 Tapes and Clamps**

All tapes and clamps must meet the requirements of §150.0(m).

Cloth-backed, rubber-adhesive tapes must be used only in combination with mastic and draw bands or have on the backing the phrase "CEC approved," a drawing of a fitting to plenum joint in a red circle with a slash through it (the international symbol of prohibition), and a statement that it cannot be used to seal fittings to plenums and junction box joints.

**4.4.4.2 All Joints Must Be Mechanically Fastened**

For residential round metal ducts, installers must overlap the joint by at least 1½ inches and use three sheet metal screws equally spaced around the joint. (See Figure 4-17.)

**Figure 4-17: Connecting Round Metallic Ducts**

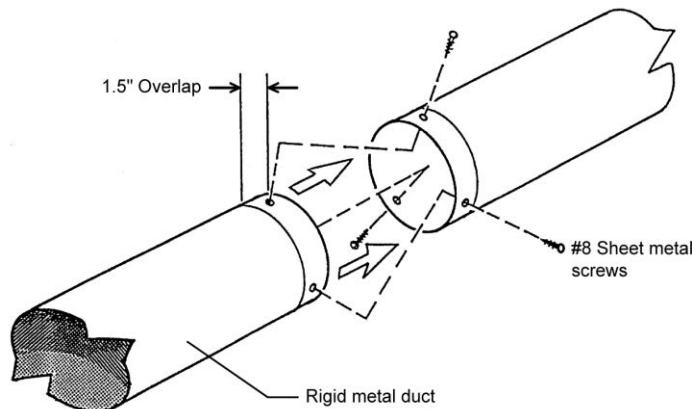

Source: Richard Heath & Associates/Pacific Gas and Electric Company

For round, nonmetallic flex ducts, installers must insert the core over the metal collar or fitting by at least 1 inch. This connection may be completed with either mesh, mastic and a clamp, or two wraps of tape and a clamp.

For a mesh and mastic connection, the installer must first tighten the clamp over the overlapping section of the core, apply a coat of mastic covering both the metal collar

and the core by at least 1 inch, and then firmly press the fiber mesh into the mastic and cover with a second coat of mastic over the fiber mesh. (See Figure 4-18.)

**Figure 4-18: Connecting Flex Ducts Using Mastic and Mesh**

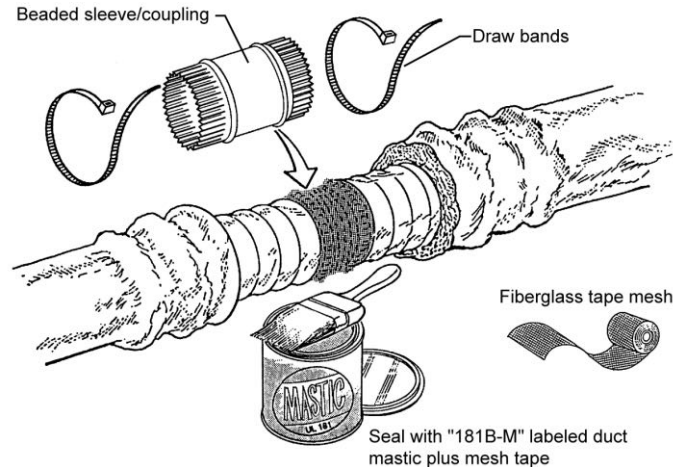

Source: Richard Heath & Associates/Pacific Gas and Electric Company

For the tape connection first apply at least two wraps of approved tape covering both the core and the metal collar by at least 1 inch; then tighten the clamp over the overlapping section of the core. (See Figure 4-19.)

**Figure 4-19: Connecting Flex Ducts Using Tape and Clamps**

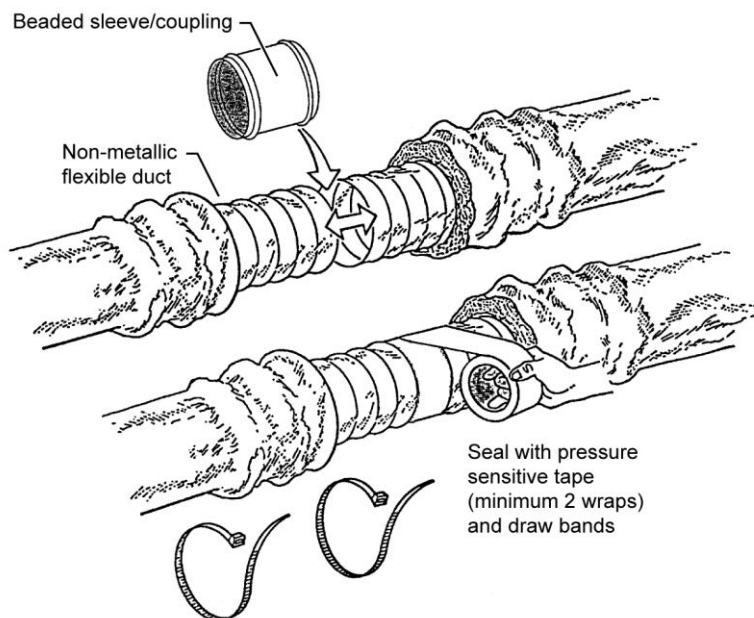

Source: Richard Heath & Associates/Pacific Gas and Electric Company

**4.4.4.3 All Joints Must Be Made Airtight**

§150(m)

Seal all joints with either mastic, tape, aerosol sealant, or other duct-closure system that meets the applicable requirements of UL 181, UL 181A, UL 181B, or UL 723. Duct systems shall not use cloth-backed, rubber-adhesive duct tape regardless of UL designation, unless it is installed in combination with mastic and clamps. The Energy Commission has approved three cloth-backed duct tapes with special butyl synthetic adhesives rather than rubber adhesive to seal flex duct to fittings. These tapes are:

1. Polyken 558CA, manufactured by Berry Plastics Tapes and Coatings Division.
2. Nashua 558CA, manufactured by Berry Plastics Tapes and Coatings Division.
3. Shurtape PC 858CA, manufactured by Shurtape Technologies, Inc.

These tapes passed Lawrence Berkeley Laboratory tests comparable to those that cloth-backed, rubber-adhesive duct tapes failed. (The LBNL test procedure has been adopted by the American Society of Testing and Materials as ASTM E2342.) These tapes are allowed to be used to seal flex duct to fittings without being in combination with mastic. These tapes cannot be used to seal other duct system joints, such as the attachment of fittings to plenums and junction boxes. These tapes have on the backing a drawing of a fitting to plenum joint in a red circle with a slash through it (the international symbol of prohibition) to illustrate where they are not allowed to be used, installation instructions in the packing boxes that explain how to install them on duct core to fittings, and a statement that the tapes cannot be used to seal fitting to plenum and junction box joints.

Mastic and mesh should be used where round or oval ducts join flat or round plenums. (See Figure 4-20.)

**Figure 4-20: Sealing Metallic Ducts With Mastic and Mesh**

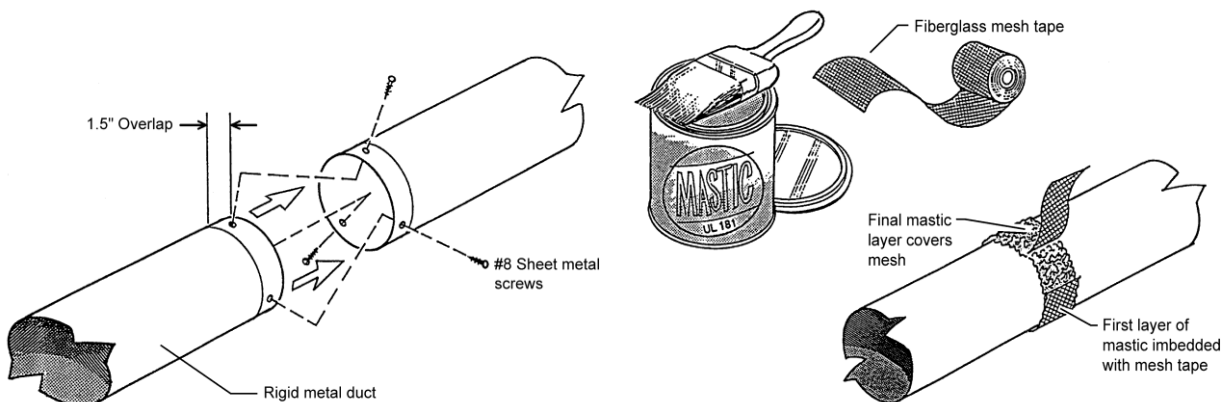

Source: Richard Heath & Associates/Pacific Gas and Electric Company

All ducts must be adequately supported.

Rigid ducts and flex ducts may be supported on rigid building materials between ceiling joists or on ceiling joists.

For rigid round metal ducts that are suspended from above, hangers must occur 12 ft. apart or less. (See Figure 4-21)

**Figure 4-21: Options for Suspending Rigid Round Metal Ducts**

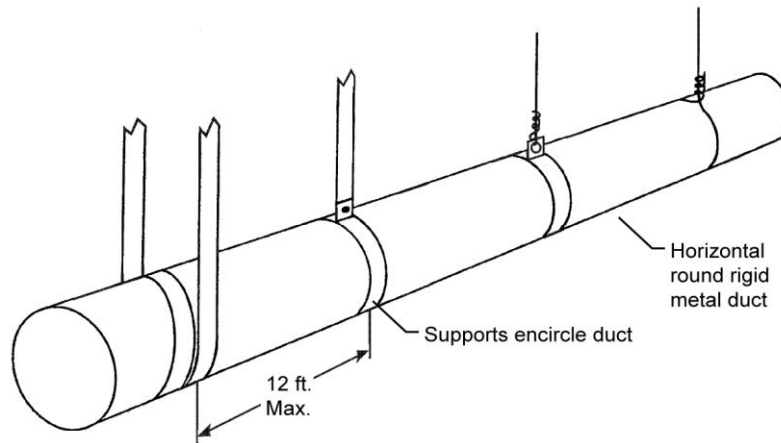

Source: Richard Heath & Associates/Pacific Gas and Electric Company

For rectangular metal ducts that are suspended from above, hangers must occur at a minimum of 4 ft. to 10 ft., depending on the size of the ducts. (See Table 6-2A in Appendix A of the California Mechanical Code and refer to Figure 4-22.)

**Figure 4-22: Options for Suspending Rectangular Metal Ducts**

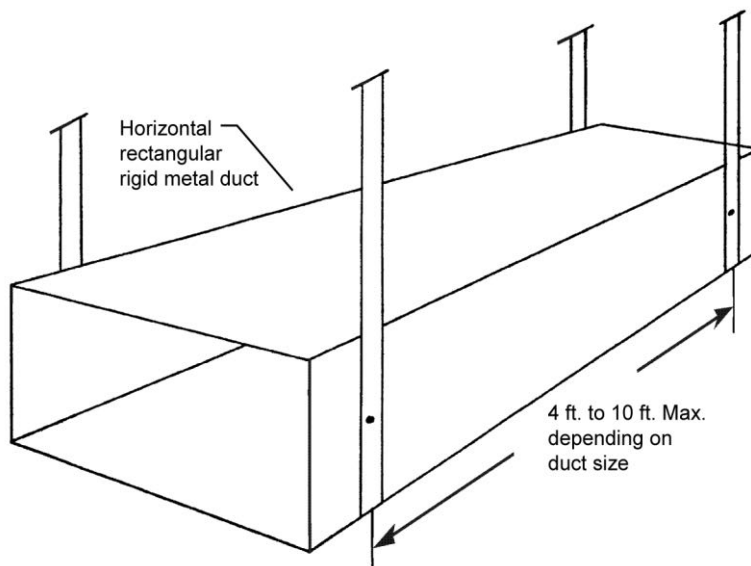

Source: Richard Heath & Associates/Pacific Gas and Electric Company

For flex ducts that are suspended from above, hangers must occur at 4 ft. apart or less, and all fittings and accessories must be supported separately by hangers. (See Figure 4-23.)

**Figure 4-23: Minimum Spacing for Suspended Flex Ducts**

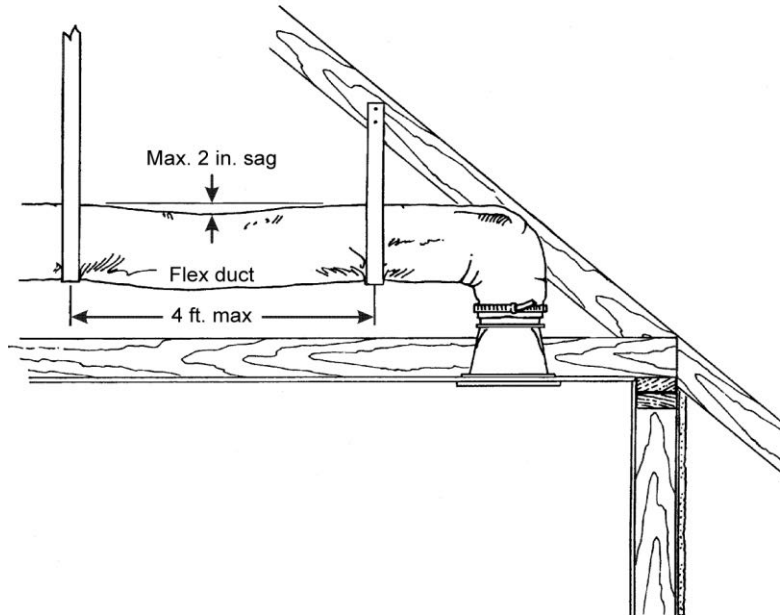

Source: Richard Heath & Associates/Pacific Gas and Electric Company

For vertical runs of flex duct, support must occur at 6 ft. intervals or less. (See Figure 4-24)

**Figure 4-24: Minimum Spacing for Supporting Vertical Flex Ducts**

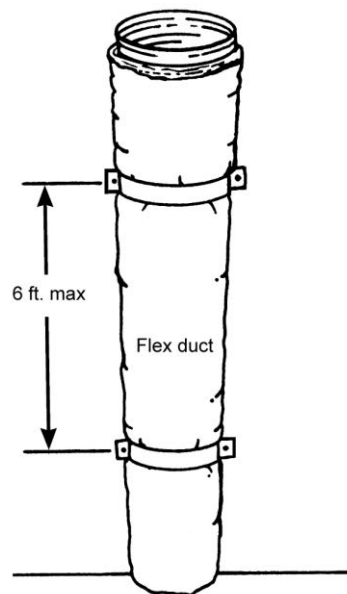

Source: Richard Heath & Associates/Pacific Gas and Electric Company

The routing and length of all duct systems can have significant effects on system performance due to possible increased airflow resistance. The Energy Commission recommends using the minimum length of duct to make connections and the minimum possible number of turns.

For flexible ducts, the Energy Commission recommends fully extending the duct by pulling the duct tightly, cutting off any excess duct, and avoiding bending ducts across sharp corners or compressing them to fit between framing members. (See Figure 4-25) Also avoid incidental contact with metal fixtures, pipes, or conduits or installation of the duct near hot equipment such as furnaces, boilers, or steam pipes that are above the recommended flexible duct use temperature.

**Figure 4-25: Minimizing Radius for Flex Duct Bends**

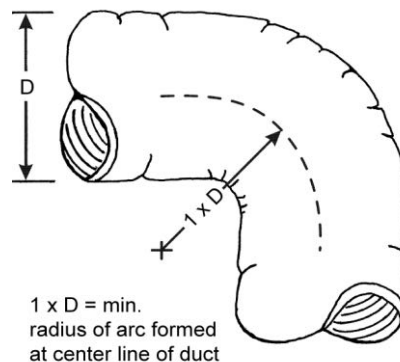

Source: Richard Heath & Associates/Pacific Gas and Electric Company

All joints between two sections of duct must be mechanically fastened and substantially airtight. For a flex duct, this must consist of a metal sleeve no less than 4 inches between the two sections of flex duct.

All joints must be properly insulated. For flex ducts, installers must pull the insulation and jacket back over the joint and use a clamp or two wraps of tape. Aerosol sealant injection systems are an alternative that typically combines duct testing and duct sealing in one process.

Figure 4-26 shows the computer-controlled injection fan temporarily connected to the supply duct. The plenum is blocked off by sheet metal to prevent the sealant from entering the furnace. Supply air registers are also blocked temporarily to keep the sealant out of the house. Ducts must still be mechanically fastened even if an aerosol sealant system is used.

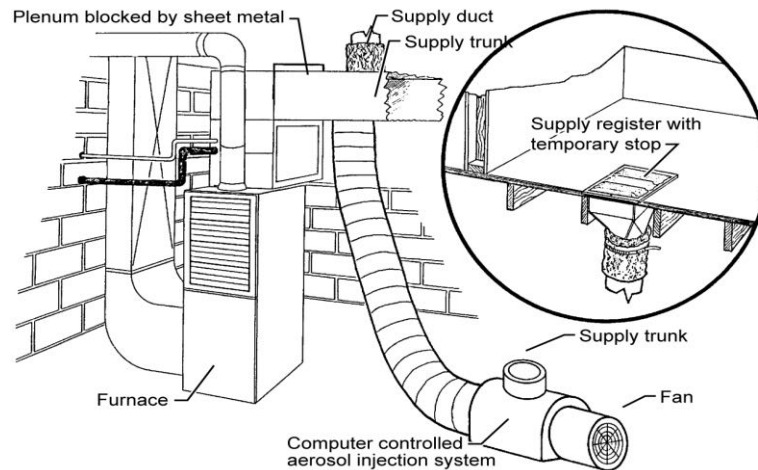
**Figure 4-26: Computer-Controlled Aerosol Injection System**

Source: Richard Heath & Associates/Pacific Gas and Electric Company

## 4.5 Controls

### 4.5.1 Thermostats

Automatic setback thermostats can add comfort and convenience to a home. Occupants can wake up to a warm house in the winter and come home to a cool house in the summer without using unnecessary energy.

§110.2 (b) & (c), §150.0(i)

A thermostat is always required for central systems whether the prescriptive or performance compliance method is used. An exception is allowed only if the system is one of the following non-central types:

1. Non-central electric heaters.
2. Room air conditioners.
3. Room air conditioner heat pumps.
4. Gravity gas wall heaters.
5. Gravity floor heaters.
6. Gravity room heaters.
7. Wood stoves.
8. Fireplace or decorative gas appliances.

When it is required, the setback thermostat must have a clock or other mechanism that allows the building occupant to schedule the heating and/or cooling set points for at least four periods over 24 hours.

If more than one piece of heating equipment is installed in a residence or dwelling unit of a multifamily building, the setback requirement may be met by controlling all heating units by one thermostat or by controlling each unit with a separate thermostat. Separate heating units may be provided with a separate on/off control capable of overriding the thermostat.

Thermostats for heat pumps must be “smart thermostats” that minimize the use of supplementary electric resistance heating during startup and recovery from setback, as discussed earlier in the heating equipment section.

---

**Example 4-6****Question:**

Am I exempt from the requirement for a thermostat if I have a gravity wall heater or any of the equipment types listed in the exception to §110.2(c)?

**Answer:**

Yes.

---

#### **4.5.2 Zonal Control for Compliance Credit**

An energy compliance credit is provided for zoned heating systems, which save energy by providing selective conditioning for only the occupied areas of a house. A house having at least two zones (living and sleeping) may qualify for this compliance credit. The equipment may consist of one heating system for the living areas and another system for sleeping areas or a single system with zoning capabilities, set to turn off the sleeping areas in the daytime and the living area unit at night. (See Figure 4-27)



Figure 4-27: Zonal Control Example

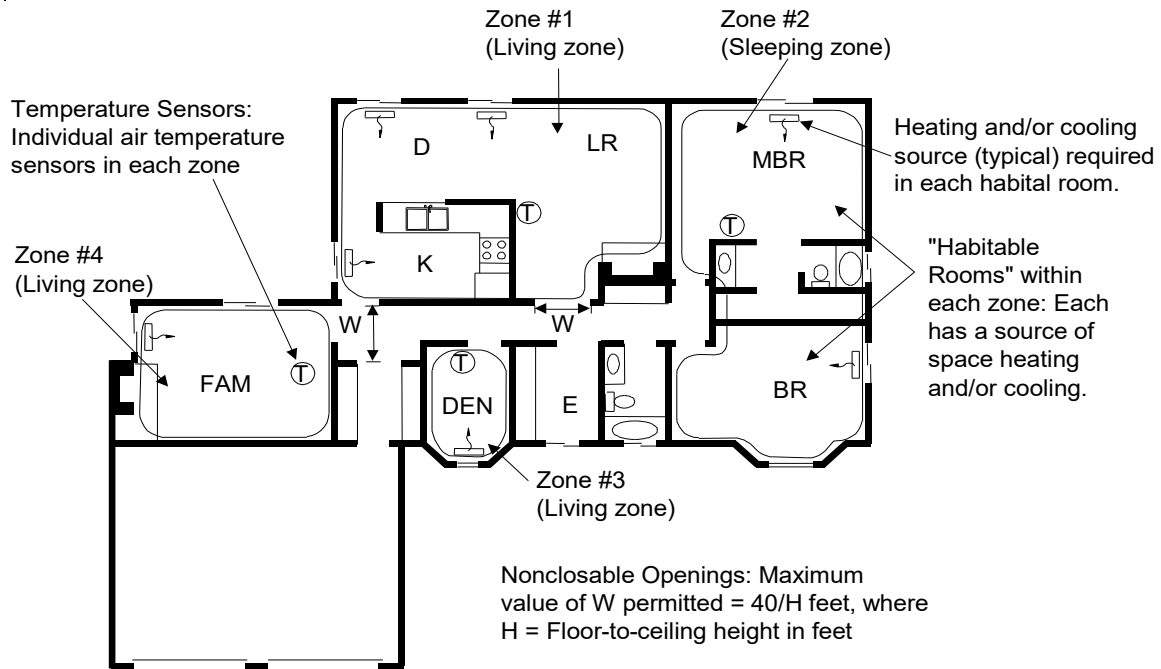

Source: Richard Heath & Associates/Pacific Gas and Electric Company

There are unique eligibility and installation requirements for zonal control to qualify under the Energy Standards. The following steps must be taken for the building to show compliance with the standards under this exceptional method:

1. **Temperature Sensors.** Each thermal zone, including a living zone and a sleeping zone, must have air temperature sensors that provide accurate temperature readings of the typical condition in that zone.
2. **Habitable Rooms.** For systems using central forced-air or hydronic heating, each habitable room in each zone must have a source of space heating, such as forced-air supply registers, radiant tubing, or a radiator. For systems using a combination of a central system and a gas-vented fireplace or other conditioning units, the zone served by the individual conditioning unit can be limited to a single room. Bathrooms, laundry, halls and/or dressing rooms are not habitable rooms.
3. **Noncloseable Openings.** The total noncloseable opening area (W) between adjacent living and sleeping thermal zones (such as halls, stairwells, and other openings) must be less than or equal to 40 ft<sup>2</sup>. All remaining zonal boundary areas must be separated by permanent floor-to-ceiling walls and/or fully solid, operable doors capable of restricting free air movement when closed.
4. **Thermostats.** Each zone must be controlled by a central automatic dual-setback thermostat that can control the conditioning equipment and maintain preset temperatures for varying periods in each zone independent of the other.

Thermostats controlling vented gas fireplace heaters that are not permanently mounted to a wall are acceptable as long as they have the dual-setback capabilities.

Other requirements specific to forced-air-ducted systems include the following:

1. Each zone must be served by a return air register located entirely within the zone. Return air dampers are not required.
2. Supply air dampers must be manufactured and installed so that when they are closed, there is no measurable airflow at the registers.
3. The system must be designed to operate within the equipment manufacturer's specifications.
4. Air is to positively flow into, through, and out of a zone only when the zone is being conditioned. No measurable amount of supply air is to be discharged into unconditioned or unoccupied space to maintain proper airflow in the system.

Although multiple thermally distinct living and/or sleeping zones may exist in a residence, the correct way to model zonal control for credit requires only two zones: a living zone and a sleeping zone. All separate living zone components must be modeled as one living zone; the same must be done for sleeping zones.

#### Example 4-7

**Question:**

In defining the living and sleeping zones for a home with a zonally controlled HVAC system, can laundry rooms and bathrooms (which are not habitable spaces) be included on whichever zone they are most suited to geographically (for example, a bathroom located near bedrooms)?

**Answer:**

Yes. For computer modeling, include the square footage of any nonhabitable or indirectly conditioned spaces with the closest zone.

#### Example 4-8

**Question:**

I have two HVAC systems and want to take zonal control credit. Can the return air grilles for both zones be located next to each other in the 5 ft. wide by 9 ft. high hallway (in the same zone)?

**Answer:**

No. Because of the need to prevent mixing of air between the conditioned zone and the unconditioned zone, it is necessary to (1) have the return air for each zone within that zone, and (2) limit any noncloseable openings between the two zones to 40 ft<sup>2</sup> or less. Unless these criteria and the other criteria listed in this chapter can be met, credit for a zonally controlled system cannot be taken.

Example 4-9

**Question:**

Can a gas-vented fireplace be used for zonal control heating, and qualify for the zonal control credit?

**Answer:**

Gas-vented fireplaces that meet zonal control requirements may qualify for the zonal control credit.

Example 4-10

**Question:**

Does a gas-vented fireplace with a handheld remote thermostat meet the thermostat requirement for the two-zone modeling credit?

**Answer:**

Yes, as long as the thermostat has manual “on” to start, automatic setback capability, and temperature preset capability, it does not have to be permanently wall-mounted.

## 4.6 Indoor Air Quality and Mechanical Ventilation

*§150.0(o), §150.2(a)1C, and §150.2(a)2C*

As residential buildings have been tightened over the last several code cycles to improve energy performance, the dilution of indoor air through natural ventilation has been significantly reduced. As a result, the importance of controlling indoor pollutants generated by kitchen ranges during food preparation and from common building materials, cleaners, finishes, packaging, furniture, carpets, clothing, and other products has increased. Energy Commission-sponsored research has revealed that concentration of pollutants such as formaldehyde are higher than expected, and that many occupants do not open windows regularly for ventilation. The 2019 Energy Standards include requirements for mandatory mechanical ventilation intended to improve indoor air quality (IAQ) in homes, and requirements for MERV 13 air filtration on space conditioning systems, and ventilation systems that provide outside air to the occupiable space of a dwelling.

As specified by §150.0(o), single-family detached dwelling units, and multifamily attached dwelling units must meet the requirements of ASHRAE Standard 62.2-2016 including Addenda b, d, l, q, and s (ASHRAE 62.2), subject to the amendments specified in Section 150.0(o)1. A [copy of this version of ASHRAE 62.2](#) may be obtained at the following URL:

[https://www.techstreet.com/ashrae/standards/california-energy-commission-adopted-version-of-ansi-ashrae-standard-62-2-2016?product\\_id=2033702](https://www.techstreet.com/ashrae/standards/california-energy-commission-adopted-version-of-ansi-ashrae-standard-62-2-2016?product_id=2033702)

Opening and closing windows and continuous operation of central fan-integrated ventilation systems are not allowable options for meeting dwelling unit ventilation requirements. The requirements of ASHRAE Standard 62.2 focus on providing continuous dwelling unit mechanical ventilation, as well as local exhaust ventilation at known sources of pollutants or moisture, such as kitchens, bathrooms, and laundries.

Limiting the sources of indoor pollutants is one important method for protecting indoor air quality. Kitchen ranges used for preparation of food have been identified as a source of indoor air pollution that must be addressed, and builders should adhere to the requirements of Section 4.504 of the California Green Building Standards Code for the selection of materials and finishes that have no or low emissions of air pollutants such as formaldehyde and volatile organic compounds (VOCs). The California Air Resources Board (CARB) also provides guidance for reducing indoor air pollution in homes. For more information, see the CARB Indoor Air Quality Guidelines:

<http://www.arb.ca.gov/research/indoor/guidelines.htm>

This section will cover compliance and enforcement, typical design solutions, energy consumption issues, and other requirements specified by ASHRAE 62.2 as amended in the 2019 Title 24 standards. The key changes in the adopted 2016 version of ASHRAE 62.2 and Title 24 Part 6 amendments to 62.2 include the following:

1. ASHRAE 62.2 now covers mid-rise and high-rise residential occupancies, as well as single-family detached and low-rise attached multifamily dwellings.
2. For single-family homes, the standard requires higher rates of dwelling unit mechanical ventilation than previously. An adjustment to the ventilation rate is provided to account for the effects of the envelope infiltration, which varies by climate zone (Table 4-14). Homes sealed to a leakage rate of less than 2 ACH50 will require larger fans to compensate for the decrease in effective ventilation due to infiltration.
3. Single-family detached dwellings and townhomes using balanced ventilation systems will require lower ventilation rates as compared to the rates required when exhaust or supply-only ventilation is used.
4. Compliance with required dwelling unit ventilation using *variable* mechanical ventilation systems (intermittent or variable operation) requires the average mechanical ventilation rate (in CFM) over a three-hour period to be greater

than or equal to the ventilation rate used for continuous ventilation. Otherwise, more complicated control strategies may be used if the system operation complies with the “relative exposure” calculations in normative Appendix C of ASHRAE 62.2.

5. Two options for compliance with dwelling unit ventilation are allowed for multifamily attached dwelling units: (1) installation of a balanced ventilation system or (2) installation of an exhaust or supply-only system accompanied by sealing to a leakage rate of not more than 0.3 CFM50 per ft<sup>2</sup> of dwelling unit enclosure surface area.
6. Kitchen range hood fans are now required to be verified by a HERS Rater. The new verification protocol requires comparing the installed model to ratings in the Home Ventilating Institute (HVI) directory of certified ventilation products to confirm the installed range hood is rated to meet the required airflow and sound requirements specified in ASHRAE 62.2. See section 4.6.7 below for more detail. Kitchen range hood fans that exhaust more than 400 CFM at minimum speed are exempt from this requirement.

Compliance with the dwelling unit ventilation airflow specified in ASHRAE 62.2 is required in new dwelling units, in new dwelling units that are additions to an existing building, and in additions to existing dwelling units that increase the conditioned floor area of the existing dwelling unit by more than 1,000 square feet. Alterations to components of existing buildings that previously met any requirements of ASHRAE 62.2 must continue to meet requirements upon completion of the alteration(s).

The following summarizes the key requirements for most newly constructed buildings:

1. A dwelling unit mechanical ventilation system shall be provided. Typical solutions are described in Section 4.6.2 below. The airflow rate provided by the system shall be confirmed through field verification and diagnostic testing in accordance with the applicable procedures specified in Reference Residential Appendix RA3.7.
2. Kitchens and bathrooms shall have local exhaust fans vented to outdoors.
3. Clothes dryers shall be vented to outdoors.

Miscellaneous indoor air quality design requirements also apply, including the following:

1. Ventilation air shall come from outdoors and shall not be transferred from adjacent dwelling units, garages, unconditioned attics or crawl spaces.
2. Ventilation system controls shall be labeled, and the homeowner shall be provided with instructions on how to operate the system.
3. Combustion appliances shall be properly vented, and exhaust systems shall be designed to prevent back drafting.
4. Walls and openings between the house and the garage shall be sealed or gasketed.

5. Habitable rooms shall have windows with an opening ventilation area of at least 4 percent of the floor area.
6. Mechanical systems including heating and air-conditioning systems that supply air to habitable spaces shall have MERV 13 filters or better and be designed to accommodate the rated pressure drop of the system air filter at the designed airflow rate.
7. Dedicated air inlets (not exhaust) that are part of the ventilation system design shall be located away from known sources of outdoor contaminants.
8. A carbon monoxide alarm shall be installed in each dwelling unit in accordance with NFPA Standard 720.
9. Air-moving equipment used to meet the dwelling unit ventilation requirement and the local ventilation exhaust requirement shall be rated in terms of airflow and sound:
  - a. Dwelling unit ventilation and continuously operating local exhaust fans must be rated at a maximum of 1.0 sone (measurement of sound).
  - b. Demand-controlled local exhaust fans must be rated at a maximum of 3.0 sone.
  - c. Kitchen exhaust fans must be rated at a maximum of 3.0 sone at one or more airflow settings greater than or equal to 100 CFM.
  - d. Remotely located air-moving equipment (mounted outside habitable spaces) are exempt from the sound requirements provided there is at least 4 feet of ductwork between the fan and the interior grille.

#### **4.6.1 Compliance and Enforcement**

Compliance with ASHRAE 62.2 requirements must be verified by the enforcement agency, except for the following requirements that must be HERS verified in accordance with the procedures in Residential Appendix RA3.7:

- Dwelling unit ventilation airflow rate
- HVI ratings for kitchen range hood fans

All applicable certificates of compliance, installation, and verification must be registered with an approved HERS Provider.

Title 24 Part 6 amendments to ASHRAE 62.2 eliminated the requirement to use the result of a blower door measurement when calculating the required dwelling unit mechanical ventilation rate ( $Q_{fan}$ ). Instead, the  $Q_{fan}$  calculation applies a default infiltration leakage rate equivalent to 2 ACH<sub>50</sub>. Blower door testing to measure actual dwelling unit enclosure leakage is required only when performance compliance modeling uses an infiltration leakage rate less than 2 ACH<sub>50</sub> - which requires HERS verification of dwelling unit enclosure leakage for energy compliance as well as for determining  $Q_{fan}$ .

If a central heating/cooling system air-handler fan is used to ventilate the dwelling (central fan-integrated ventilation, also known as CFI ventilation), the air-handler must meet or exceed the mandatory fan efficacy criteria. This requires the installer to perform the test given in Reference Appendix RA3.3 and a HERS Rater to verify the efficacy (W/CFM) of the air-handling unit fan.

#### 4.6.1.1 Certificate of Compliance Reporting Requirements

When using the prescriptive compliance approach, the mechanical ventilation rate ( $Q_{fan}$ ) must be manually calculated using the applicable equations in Standards Section 150.0(o)1, also shown in Section 4.6.4 below. The value for  $Q_{fan}$  is required to be reported on the CF1R. When using the performance method, the compliance model automatically calculates  $Q_{fan}$  based on the inputs for conditioned floor area, number of bedrooms, and climate zone (Table 4-14), and uses the  $Q_{fan}$  ventilation airflow value when calculating the building energy use. The performance certificate of compliance (CF1R) will report the:

1. Minimum mechanical ventilation airflow rate (calculated value) that must be delivered by the system.
2. Type of ventilation system (exhaust, supply, balanced, CFI).
3. Fan efficacy (W/CFM) for the selected system.
4. Recovery efficiency (%) (applicable to HRV/ERV system types only)
5. For CFI systems--HERS verification of air handler fan efficacy is required.

The installed dwelling unit ventilation system must conform to the performance requirements on the CF1R.

The enforcement agency may require additional information/documentation describing the ventilation systems be submitted along with the CF1R at plan check.

#### 4.6.1.2 Certificate of Installation and Certificate of Verification Reporting Requirements

The builder/installer must complete certificates of installation (CF2R-MCH-01 and CF2R-MCH-27) for the dwelling. The HERS Rater must complete a certificate of verification (CF3R-MCH-27) for the dwelling.

##### 4.6.1.2.1 CF2R-MCH-01

The following information must be provided on the CF2R-MCH-01 to identify each ventilation system/fan in the dwelling that will require HERS verification.

For dwelling unit ventilation systems:

1. Ventilation system name or identification
2. Ventilation system location
3. Ventilation system control type (i.e. continuous, variable)
4. Ventilation system type (i.e. exhaust, supply, balanced, CFI).

5. Ventilation system target airflow rate (may be less than  $Q_{fan}$  if using multiple systems/fans to comply)
6. Ventilation system manufacturer name
7. Ventilation system model number
8. Control system manufacturer (if applicable)
9. Control system model number (if applicable)
10. Energy Commission certification number for variable system/control (if applicable)

For kitchen exhaust ventilation systems:

1. Kitchen exhaust control type (i.e. demand-controlled, continuous)
2. Kitchen exhaust system type (i.e. range hood, over the range (OTR) microwave, downdraft, local exhaust, other).
3. Kitchen exhaust system required airflow rate
4. Kitchen exhaust system manufacturer name
5. Kitchen exhaust system model number
6. Kitchen exhaust system HVI certification number

#### 4.6.1.2.2 **CF2R-MCH-27**

The following additional information must be provided on the CF2R-MCH-27 to document compliance with §150.0(o). Refer also to the procedures in RA 3.7.4.

For dwelling unit ventilation systems:

- Measured airflow rate of the installed dwelling unit ventilation system. For balanced systems, exhaust and supply airflows must be measured and recorded.

For kitchen exhaust ventilation systems:

- Confirmation the installed system is rated by HVI to meet the required airflow and sound requirements.

For all ventilation systems:

- Confirmation that the other applicable requirements given in Sections 6 and 7 of ASHRAE 62.2 as amended in 150.0(o)1 have been met (see Sections 4.6.7 and 4.6.8 below).

#### 4.6.1.2.3 **CF3R-MCH-27**

The following additional information must be provided on the CF3R-MCH-27 to document compliance with §150.0(o):



For dwelling unit ventilation systems:

- Measured airflow rate of the installed dwelling unit ventilation system. For balanced systems, both exhaust and supply airflows must be measured and recorded.

For kitchen exhaust ventilation systems:

- Confirmation the installed system is rated by HVI to meet the required airflow and sound requirements.

#### 4.6.2 Typical Solutions for Single-Family Dwelling Unit Ventilation

*From ASHRAE 62.2, Section 4.2, System Type.*

*The dwelling-unit mechanical ventilation system shall consist of one or more supply or exhaust fans and associated ducts and controls. Local exhaust fans shall be permitted to be part of a mechanical exhaust system. Where local exhaust fans are used to provide dwelling-unit ventilation, the local exhaust airflow may be credited toward the dwelling-unit ventilation airflow requirement. Outdoor air ducts connected to the return side of an air handler shall be permitted as supply ventilation if manufacturers' requirements for return air temperature are met.*

There are four typical solutions for meeting the dwelling unit outside air ventilation requirement:

1. Exhaust ventilation - air is exhausted from the dwelling unit and replaced by infiltration.
2. Supply ventilation - outdoor air is supplied directly to the dwelling unit after being filtered.
3. Central fan-integrated ventilation - outdoor air is ducted to the return plenum of the central space conditioner air handler. Both return air and outdoor air must be filtered.
4. Balanced ventilation – may be a single packaged unit containing supply and exhaust fans that move approximately the same airflow through a heat or energy recovery core or may use separate fans without heat exchange. In both cases, air supplied from outdoors must be filtered. (See Section 4.4.1.14 for filter requirements.)

##### 4.6.2.1 Exhaust Ventilation

Exhaust ventilation is typically provided using a quiet, continuously operating ceiling-mounted fan or attic-mounted inline fan. Air is drawn from the house or unit and exhausted to the outdoors. Outdoor air enters the house or unit through infiltration. Many high-quality, quiet fans are available for this purpose. For larger homes, more than one fan may be used. The same fan can be used to meet dwelling unit and

local (bathroom or laundry) exhaust ventilation requirements. Inline fans can be used to exhaust air from one or more bathrooms. Remotely located fans (fans mounted outside habitable spaces) are exempt from the sound requirements if there is at least 4 feet of ductwork between the fan and the interior grille.

**Figure 4-28: Exhaust Ventilation Example**

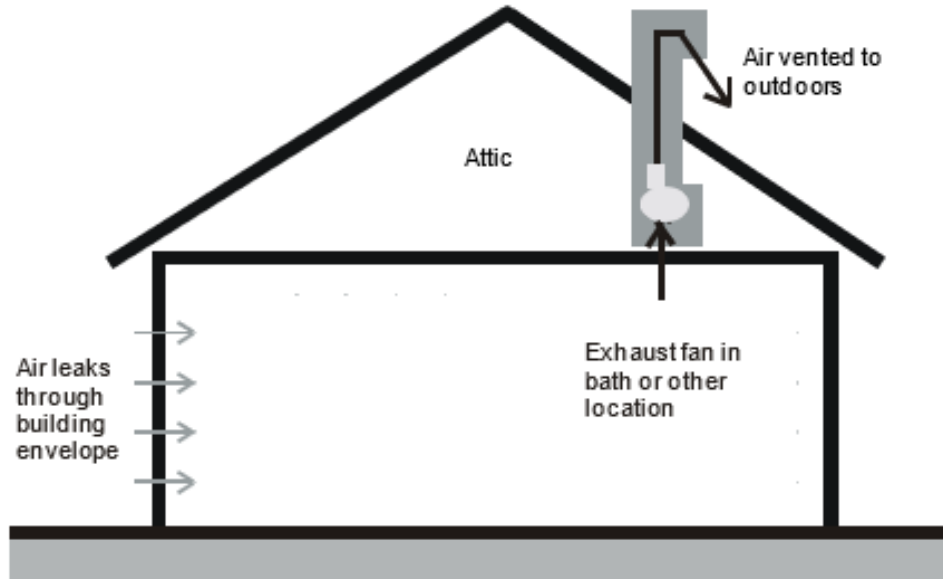

Source: California Energy Commission

#### 4.6.2.2 Supply Ventilation

Supply ventilation systems draw outdoor air into the house using a dedicated supply fan and most likely distribute ventilation air through supply ductwork, although that is not a requirement. Indoor air escapes through leaks in the building envelope (exfiltration), as shown in Figure 4-29. For larger homes, more than one fan may be used. Remotely located fans (fans mounted outside habitable spaces) are exempt from the sound requirements if there is at least 4 feet of ductwork between the fan and the interior grille. Thus, if less than 4 feet of ductwork are used, the supply fan must meet the maximum 1.0 sone rating requirement for dwelling unit ventilation fans.

Figure 4-29: Supply Ventilation Example

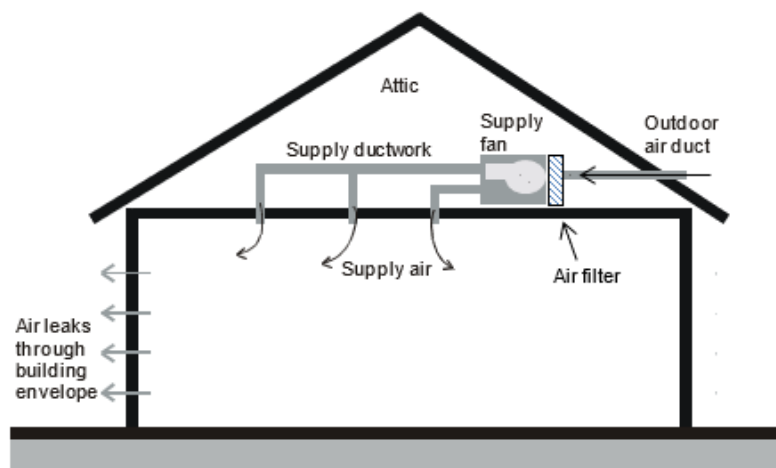

Source: California Energy Commission

Section 150.0(m)12 requires that outside air be filtered using MERV 13 (or greater) particle removal efficiency rated air filters. The filters must be accessible to facilitate replacement. Supply systems may locate the MERV 13 air filter either upstream or downstream of the fan as long as the incoming outdoor air is filtered prior to delivery to the dwelling unit habitable space. Fans may be located in attics, dropped ceiling spaces, or other spaces dedicated for installation of mechanical equipment.

The outdoor air inlet should be located to avoid areas with contaminants such as smoke produced in barbeque areas and products of combustion emitted from gas appliance vents. Air may not be drawn from attics or crawlspaces. To minimize drafts and optimize distribution, supply air can be ducted directly to bedrooms and living areas using an appropriately sized and sealed ventilation-only duct system or by connecting to the HVAC supply plenum.

#### 4.6.2.3 Central Fan-Integrated (CFI) Ventilation

The central forced-air system air handler can be configured to function as a ventilation supply system by installing an outdoor air duct that connects the return plenum of the air-handler to outdoors. This strategy, called CFI ventilation, uses negative pressure in the return plenum to draw in outdoor air, which is mixed and distributed with a larger volume of return air from the house. A motorized damper and special CFI controls must be installed to ensure the air handler delivers the required ventilation airflow regardless of whether the heating/cooling system operates to provide space conditioning. Thus, when the heating/cooling operating time is reduced during times when space conditioning is not needed, the CFI controls will operate only the system fan and outdoor air damper to provide ventilation air even if space conditioning is not needed. Because of the relatively high energy use of the central system fan, CFI systems consume greater amounts of energy compared to exhaust or supply or balanced ventilation systems. Continuous

operation of the CFI air handler fan to provide the required dwelling unit ventilation is prohibited.

Figure 4 30: Central Fan-Integrated (CFI) Ventilation Example

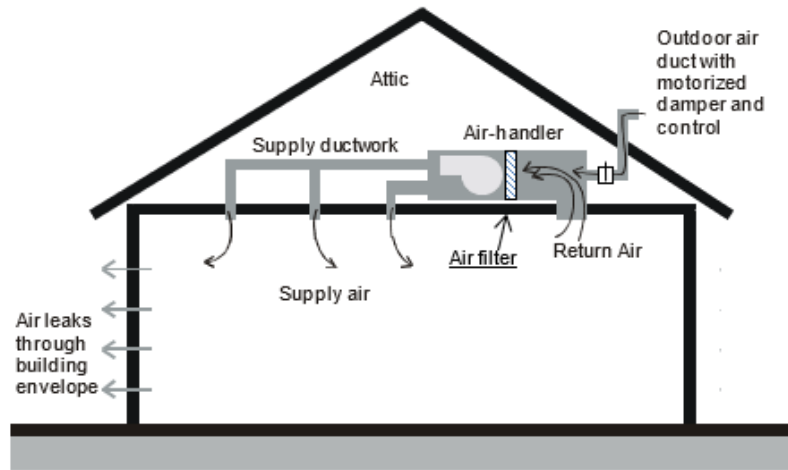

Source: California Energy Commission

Section 150.0(m)12 requires that outside air be filtered using MERV 13 (or greater) particle removal efficiency rated air filters. Filters must be accessible to simplify replacement. For CFI systems, the filters must be installed upstream of the cooling or heating coil; thus, the filter rack provided at the inlet to the air handler may be used. Otherwise, filters must be provided at the return grill(s) for the central fan, and another filter must be provided in the outside air ductwork before the point the outside air enters the return plenum of the central fan.

When considering system design and HERS verification compliance for CFI ventilation systems, it is important to distinguish between the central forced-air system fan total airflow and the much smaller outdoor ventilation airflow rate (the airflow that is induced to flow into the return plenum from outdoors). Both of these airflows must be verified by a HERS Rater. Refer to Figure 4-30 and note that the total airflow through the air handler is the sum of the return airflow and the ventilation airflow.

CFI ventilation systems, devices, and controls may be approved for use for compliance with the HERS field verification requirements for dwelling unit mechanical ventilation airflow. CFI ventilation systems must be automatically controlled by a timer or other device that assures they will operate the minimum amount of time needed to meet the ventilation requirement. The scheduling of the automatic controls must be such that the fan operates at least once every three hours and the average dwelling unit ventilation rate over any 3-hour period must be greater than or equal to the required ventilation rate  $Q_{fan}$  calculated using the applicable equations in Standards Section 150.0(o)1 (also shown in Section 4.6.4 below).

Section 150.0(o)1B specifically prohibits continuous operation of the central forced-air system of a CFI ventilation system, so CFI ventilation systems must operate

intermittently and be certified to the Energy Commission as an intermittent or variable system that will meet the minimum ventilation airflow required by Section 150.0(o).

A listing of certified CFI ventilation systems is posted at the following URL:

[http://www.energy.ca.gov/title24/equipment\\_cert/imv/](http://www.energy.ca.gov/title24/equipment_cert/imv/)

The outside air ducts for CFI ventilation systems are not allowed to be sealed/taped off during duct leakage testing. However, CFI outdoor air ductwork that uses controlled motorized dampers that open only when outdoor air ventilation is required and close when outdoor air ventilation is not required may be closed during duct leakage testing.

Because CFI ventilation systems can use a large amount of electricity annually compared to other ventilation system types, the air handlers used in CFI ventilation systems are required to meet the fan watt draw requirements given in Section 150.0(m)13B in all climate zones.

#### 4.6.2.4 **Balanced Ventilation**

Balanced systems use an exhaust fan and a supply fan to move approximately the same volume of air into and out of the dwelling. To be considered a balanced ventilation system, the total supply airflow and the total exhaust airflow must be within 20 percent of each other. For determining compliance, the average of the supply and exhaust airflows is equal to the balanced system airflow rate. (Refer to RA3.7.4.1.2.)

Some balanced systems are small packaged systems that include heat exchangers that temper incoming air with outgoing air, which reduces the thermal effect of ventilation on heating and cooling loads, but the dual fans also increase electrical energy use. They are most practical for use in tightly sealed houses and in multifamily units where exhaust type systems have difficulty drawing adequate outside air due to limited exterior wall area.

Like supply ventilation systems, balanced systems are required to be equipped with MERV 13 or better filters to remove particles from outside airflow. An example of a heat recovery ventilator is shown in Figure 4-31.

The outdoor air inlet should be located to avoid areas with contaminants such as smoke produced in barbecue areas and products of combustion emitted from gas appliance vents. Air may not be drawn from attics or crawlspaces.

Figure 4-31: Balanced Ventilation Example 1 – HRV or ERV

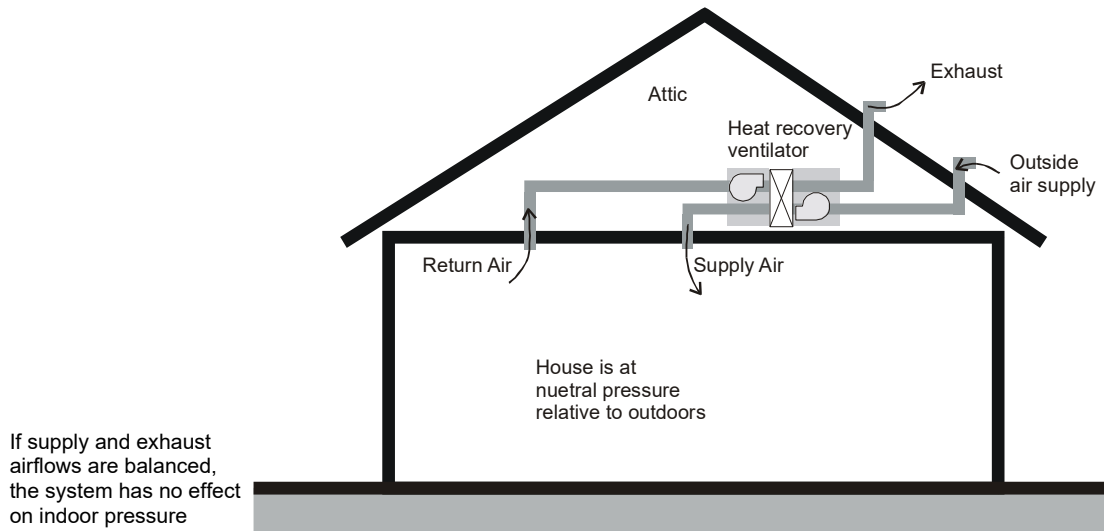

Source: California Energy Commission

Another balanced system configuration uses a stand-alone supply fan coupled with a stand-alone exhaust fan, both wired to a common switch or control to ensure they operate simultaneously. The controls must make it possible to adjust the speed of the fans for balancing the airflows. An example is shown in Figure 4-32.

Figure 4-32: Balanced Ventilation Example 2 – Separate Supply and Exhaust Fan

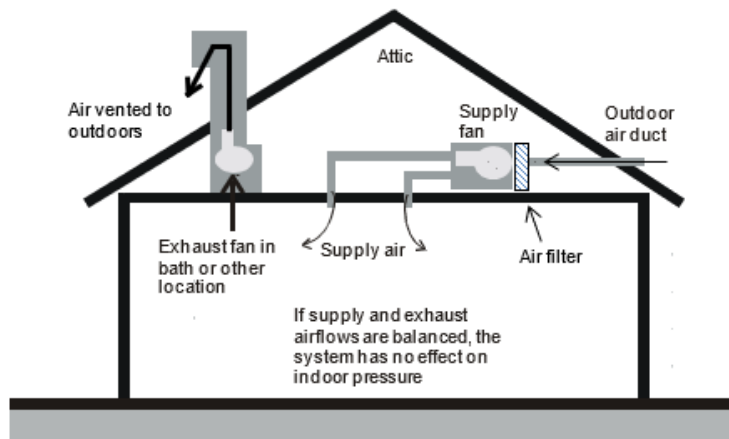

Source: California Energy Commission

### 4.6.3 Typical Solutions for Multifamily Dwelling Unit Ventilation

#### 4.6.3.1 System Types

There are generally three system types available for meeting the dwelling unit ventilation requirement (refer to Section 4.6.2 for descriptions of the system types described below):

1. Exhaust ventilation – air is exhausted from the dwelling unit and replaced by infiltration.
2. Supply ventilation – outdoor air is supplied directly to the dwelling unit after being filtered.
3. Balanced ventilation – may be a single packaged unit containing supply and exhaust fans that moves approximately the same airflow through a heat or energy recovery core or may use separate fans without heat exchange. In both cases, air supplied from outdoors must be filtered. (See Section 4.4.1.14 for air filter requirements.)

Exhaust and balanced systems are most frequently used in multifamily buildings, but supply ventilation may also be used. Exhaust (or supply) systems in low-rise buildings typically use fans located in the dwelling units that exhaust directly to the outdoors.

#### 4.6.3.2 Multifamily Building Central Shaft Ventilation Systems

Use of central ventilation fans/shafts that are shared with multiple dwelling units in the building are more common in mid-rise and high-rise buildings. When a supply or exhaust system provides dwelling unit ventilation to more than one dwelling unit, the airflows in each dwelling unit must be equal to or greater than the required (minimum) ventilation rate, and the airflows for each dwelling unit must also be balanced to be no more than 20 percent greater than the specified rate (See Standards Section 150.0(o)1F). The specified rate for the systems that share a common fan/shaft may be the minimum rate required for compliance, in which case each of the dwellings receiving airflow from a common fan/shaft must have ventilation airflow no more than 20 percent greater than the minimum dwelling unit ventilation airflow required by Equation 150.0-B. If the lowest airflow provided to any of the dwellings served by the common fan/shaft is a specific percent value greater than the minimum required for compliance, then the each of the dwellings receiving airflow from that common fan/shaft must have ventilation airflow no more than 20 percent greater than that lowest dwelling unit ventilation airflow. For example, if the lowest ventilation airflow among all dwellings served by the common fan/shaft is 2 percent greater than the minimum required for compliance, then all dwellings served by the common fan/shaft must be balanced to have ventilation airflow that is no more than 22 percent greater than the minimum ventilation airflow required for compliance.

These systems must use balancing devices to ensure the dwelling-unit airflows can be adjusted to meet this balancing requirement. These system balancing devices

may include, but are not limited to, constant air-regulation devices, orifice plates, and variable-speed central fans.

Since supply and exhaust ventilation system types are required to operate continuously in multifamily dwellings (see Section 150.0(o)1Eii), and since CFI systems are prohibited from operating continuously to provide the required dwelling unit ventilation (see Section 150.0(o)1B), the CFI ventilation system type is not allowed to be used in multifamily dwellings.

#### **4.6.3.3 Multifamily Dwelling Unit Compartmentalization – Reducing Dwelling Unit Enclosure Leakage**

Transfer air is the airflow between adjacent dwelling units in a multifamily building that can be a major contributor to poor indoor air quality in the dwelling units. Transfer airflow is caused by differences in pressure between adjacent dwelling units that force air to flow through leaks in the dwelling unit enclosure. The pressure differences may be due to stack effects and wind effects, but unbalanced mechanical ventilation is also a major contributor to this problem. It is desirable to minimize or eliminate leaks in all the dwelling enclosures in the building – to compartmentalize the dwellings - to prevent pollutants such as tobacco smoke, pollution generated from food preparation in the kitchen, odors, and other pollutants from being transferred to adjacent dwellings in the building.

Title 24 provides two compliance paths for mechanical ventilation which improve compartmentalization in multifamily buildings (choose one):

1. Install a balanced ventilation system. This may consist of either a single ventilation unit (such as an ERV or HRV) or may consist of separate supply and exhaust fans that operate simultaneously and are controlled to balance the supply and exhaust airflows. The outdoor ventilation supply air must be filtered (MERV 13 or better).
2. Verify that the dwelling unit leakage is not greater than 0.3 CFM per ft<sup>2</sup> of dwelling unit enclosure area using the procedures in RA3.8 (blower door test). If the dwelling unit enclosure passes this blower door test, use of continuously operating supply ventilation systems, or continuously operating exhaust ventilation systems in that dwelling is allowed.

#### **4.6.4 Dwelling Unit Ventilation Airflow Measurement**

Residential Appendix RA3.7.4 provides direction for measurement of supply, exhaust, and balanced system types. These measurement procedures are applicable when there is a fixed airflow rate required for compliance, such as for systems that operate continuously at a specific airflow rate or systems that operate intermittently at a fixed speed (averaged over any three-hour period), according to a fixed timer pattern for which the programmed pattern is verifiable by a HERS Rater on site. (Refer to ASHRAE 62.2 Section 4.5.1 Short Term Average Ventilation.)



Variable or intermittent operation that complies with ASHRAE 62.2 Sections 4.5.2 and 4.5.3 complies with the dwelling unit mechanical ventilation requirements by use of varying ventilation airflow rates based on complicated calculations for relative exposure as specified in ASHRAE 62.2 Normative Appendix C. These calculation procedures provide the basis for "smart" ventilation controls implemented by use of digital controls that rely on the manufacturer's product-specific algorithms or software. Any ventilation system models that use these complex ventilation system controls in a ventilation product designed to be used to comply with Standards Section 150.0(o) must submit an application to the Energy Commission to have the ventilation technology approved. These manufacturers are expected to provide with their applications evidence that the system will perform to provide the required dwelling unit mechanical ventilation. The manufacturers are also expected to provide a method that could be used by a HERS Rater to verify that an installed system is operating as designed.

Listings of systems approved by the Energy Commission and certified by the manufacturer are located at the following URL:

[http://www.energy.ca.gov/title24/equipment\\_cert/imv/](http://www.energy.ca.gov/title24/equipment_cert/imv/)

#### 4.6.5 Dwelling Unit Ventilation Rate (Section 4 of ASHRAE 62.2)

Dwelling unit ventilation systems may operate continuously or on a short-term basis. If fan operation is not continuous, the average ventilation rate over any three-hour period must be greater than or equal to the  $Q_{fan}$  value calculated using the equations in this section.

ASHRAE 62.2 provides for scheduled ventilation and real-time control, but these control approaches require "equivalent exposure" calculations using methods in Normative Appendix C, and complex controls would be required to operate the fan.

Equations for calculating  $Q_{fan}$  (the required mechanical ventilation rate) for both single- and multifamily buildings are listed below. Single-family detached dwelling units and attached dwelling units not sharing ceilings or floors with other dwelling units, occupiable spaces, public garages, or commercial spaces (e.g. duplexes and townhomes) are allowed to take credit for the building infiltration in the calculations as described below. Use of a building infiltration credit is not applicable to calculation of the required dwelling unit mechanical ventilation for multifamily dwelling units.

A new aspect of the ventilation calculations for the 2019 standards is that the building infiltration rate ( $Q_{inf}$ ) varies by climate zone (Table 4-14) and building height. Therefore, the value for  $Q_{fan}$  for a single-family dwelling or townhome will also vary based on climate zone and building height.

When the performance compliance approach is used, the compliance software completes all the calculations given in Equations 4-1, 4-2, 4-3, and 4-4, and  $Q_{fan}$  is reported on the CF1R. If the prescriptive compliance approach is used, the Data Registry will perform the calculations, and the value for  $Q_{fan}$  will be recorded on the CF1R.

#### 4.6.5.1 Total Ventilation Rate ( $Q_{tot}$ )

The total ventilation rate is the combined volume of ventilation air provided by infiltration and the mechanical ventilation provided from fans, as follows:

$$Q_{tot} = 0.03A_{floor} + 7.5(N_{br} + 1) \quad \text{Equation 4-1}$$

Where:

$Q_{tot}$  = total required ventilation rate (CFM)

$A_{floor}$  = conditioned floor area (ft<sup>2</sup>)

$N_{br}$  = number of bedrooms (not less than one)

For multifamily units, the installed ventilation system must deliver the total ventilation rate  $Q_{tot}$  calculated from Equation 4-1.

#### 4.6.5.2 Infiltration Rate ( $Q_{inf}$ )

For single-family homes, when determining the required dwelling unit mechanical ventilation airflow rate ( $Q_{fan}$  in Equation 4-4), the calculated value for estimated infiltration rate ( $Q_{inf}$  in Equation 4-2) is deducted from the value of  $Q_{tot}$  (determined by Equation 4-1). The calculated value for estimated infiltration rate depends on the building leakage, building height, and the weather and shielding factor, which varies by climate zone (Table 4-14). A default envelope leakage value of 2 ACH<sub>50</sub> is mandatory for the fan sizing calculations unless a blower door measurement is performed that determines a leakage rate below 2 ACH<sub>50</sub>. Leakage in ACH<sub>50</sub> must be converted to CFM<sub>50</sub> for use in subsequent calculations. Conversion of 2 ACH<sub>50</sub> is shown in Equation 4-2.

$$Q_{50} = V_{du} \times 2 \text{ ACH}_{50} / 60 \quad \text{Equation 4-2}$$

Where:

$Q_{50}$  = leakage rate at 50 Pa, CFM

$V_{du}$  = dwelling unit conditioned volume, ft<sup>3</sup>

$ACH_{50}$  = air changes per hour at 50 Pa (0.2 inch water)

$V_{du}$  can be approximated by multiplying the average ceiling height by the dwelling conditioned floor area. If the field-verified value for ACH<sub>50</sub> is less than 2, then the verified value is used in Equation 4-2 instead of 2.

The effective annual infiltration rate ( $Q_{inf}$ ), is calculated using the weather/shielding factor (wsf) for the applicable climate zone and the building height. See Table 4-14 below and Standards Table 150.0-D for values for wsf.

$$Q_{inf} = 0.052 \times Q_{50} \times wsf \times [H/H_r]^{0.4} \quad \text{(CFM)} \quad \text{Equation 4-3}$$

Where:

$Q_{inf}$  = effective annual infiltration rate, CFM

$Q_{50}$  = leakage rate at 50 Pa, CFM

$wsf$  = weather and shielding factor from Table 4-14

$H$  = vertical distance between the lowest and highest above-grade points within the pressure boundary

$H_r$  = reference height = 8.2 ft

The number of stories multiplied by the average ceiling height (as entered in compliance software) provides sufficient accuracy for determining  $H$ .

**Table 4-14: Weather and Shielding Factors by Climate Zone**

CZ	WSF	CZ	WSF
1	0.56	9	0.39
2	0.49	10	0.42
3	0.54	11	0.50
4	0.48	12	0.51
5	0.52	13	0.45
6	0.45	14	0.58
7	0.40	15	0.45
8	0.36	16	0.44

#### 4.6.5.3 Required Mechanical Ventilation Rate ( $Q_{fan}$ )

The required mechanical ventilation rate,  $Q_{fan}$  is the total outside airflow required to be supplied to (or total indoor air required to be exhausted from) the building by fans. Balanced ventilation system types must provide an average of the supply and exhaust airflows that is greater than or equal to  $Q_{fan}$ .

$Q_{fan}$  is calculated using Equation 4-4 below, which uses the values for  $Q_{tot}$  and  $Q_{inf}$  determined above. Equation 4-4 accounts for reduced exterior wall leakage area in attached units (e.g. townhomes and duplexes). Equation 4-4 also accounts for the differences in ventilation effectiveness of balanced systems compared to exhaust/supply (unbalanced) systems due to varying dwelling infiltration leakage rates. If  $Q_{fan}$  is less than 10 CFM, then no fan is required.

$$Q_{fan} = Q_{tot} - \Phi ( Q_{inf} \times A_{ext} ) \tag{Equation 4-4}$$

Where:

$Q_{total}$  = total required ventilation rate (CFM)

$Q_{inf}$  = effective annual average infiltration rate (CFM)

$\Phi = 1$  for balanced ventilation systems or  $Q_{inf}/Q_{tot}$  for other system types

$A_{ext} = 1$  for single-family detached homes. For attached dwelling units not sharing ceilings or floors with other dwelling units, occupiable spaces, public garages, or commercial spaces (e.g. duplexes and townhomes),  $A_{ext}$  is the ratio of exterior envelope surface area that is not attached to garages or other dwelling units to total envelope surface area.

For multifamily dwelling units,  $Q_{fan} = Q_{tot}$ .

#### Example 4-11 – Required Ventilation

##### Question:

What is the required continuous ventilation rate for a three-bedroom, 1,800 ft<sup>2</sup> townhouse located in Climate Zone 8 that has 9-foot ceilings, and where 25% of the exterior wall surface area adjoins another unit? Ventilation is provided by a bathroom exhaust fan. No extraordinary measures have been taken to seal the building.

##### Answer:

Equation 4-1 yields a total ventilation rate of 84 CFM

$$Q_{tot} = 0.03A_{floor} + 7.5(N_{br} + 1) = 0.03(1800) + 7.5(3 + 1) = 84 \text{ CFM}$$

The volume is 1,800 x 9 = 16,200 ft<sup>3</sup>. Solving for Equation 4-2 results in a leakage rate of 540 CFM

$$Q_{50} = V_{du} \times 2 \text{ ACH}_{50} / 60 = 16,200 \times 2 / 60 = 540 \text{ CFM}$$

Using Equation 4-3:  $Q_{inf} = 0.052 \times Q_{50} \times wsf \times [H/H_r]^{0.4} = 0.052 \times 540 \times 0.36 \times (18/8.2)^{0.4} = 14 \text{ CFM}$

And applying Equation 4-4, the mechanical ventilation system must move 82 CFM.

$$Q_{fan} = Q_{tot} - (Q_{inf}/Q_{tot})(Q_{inf} \times A_{ext}) = 84 - (14/84)(14 \times (1-0.25)) = 82 \text{ CFM}$$

Due to the reduction in infiltration resulting from reduced exterior wall area and to the use of an exhaust fan instead of a balanced system, the effective infiltration credit is only 2 CFM.

#### Example 4-12

##### Question:

The two-story house I am building in Climate Zone 12 has a floor area of 2,240 ft<sup>2</sup> and four bedrooms. I am using an HRV that delivers 80 CFM of outdoor air and exhausts 90 cfm of indoor air. My calculations come out to 86 CFM. Can I use this system?

##### Answer:

No. For balanced systems, the supply and exhaust airflows can be averaged, and in this case, they average 85 CFM, which is slightly less than the required 86 CFM.

The nominal rating of a fan can be different than what it actually delivers when installed and connected to ductwork, so designers should always include a safety margin when sizing equipment. The length and size of ducting should be used to calculate the pressure drop. This is why dwelling unit ventilation rates must be verified by a HERS Rater.

#### Example 4-13

**Question:**

A 2,300 ft<sup>2</sup> house has exhaust fans running continuously in two bathrooms, providing a total exhaust flow rate of 90 CFM, but the requirement is 98 CFM. What are the options for providing the additional 8 CFM?

**Answer:**

Option 1: The required additional CFM could be provided either by increasing the size of either or both exhaust fans such that the combined airflow exceeds 98 CFM.

Option 2: Another solution would be to use a balanced system, which may reduce the airflow requirement to below 90 CFM. Adding another 8 CFM fan is not an acceptable solution.

#### Example 4-14

**Question:**

A CFI system is connected to the return air plenum of a furnace such that when operating, 10% of the air supplied by the furnace is outdoor air. The CFI control limits furnace fan operation to 30 minutes of every hour. If the house requires 100 CFM of continuous ventilation air, what volume of air must the furnace deliver?

**Answer:**

Since the furnace operates half the time, the volume of outside air delivered when it is operating must be  $2 \times 100 = 200$  CFM. Therefore, the furnace must be able to deliver  $200/0.1 = 2,000$  CFM.

#### Example 4-15

**Question:**

Can an exhaust fan be used to supplement ventilation air provided by a CFS system?

**Answer:**

Yes. In the example above, if an exhaust fan is operated continuously to deliver 50 CFM, then the volume of air required of the CFI system is reduced to 100 CFM, or an average of 50 CFM over the hour such that the sum of ventilation air delivered averages 100 CFM. A 1,000 CFM furnace providing 10% outside air could be used in this case. Even though such a combined ventilation system is partially balanced, it would not qualify as a balanced system in the calculation of  $Q_{fan}$ .

#### Example 4-16

**Question:**

I want to provide controls that disable the ventilation system so it does not bring in outside air during the hottest two hours of the day, and the calculations show I need 80 CFM continuous. How large must my fan be?

**Answer:**

If the average rate over three hours is 80 CFM and the fan only operates one hour, then it must be capable of delivering  $3 \times 80 = 240$  CFM. ASHRAE 62.2 does not allow averaging ventilation over more than a three-hour period.

---

**4.6.5.4 Control and Operation**

*From ASHRAE 62.2, Section 4.4, Control and Operation. A readily accessible manual ON-OFF control, including but not limited to a fan switch or a dedicated branch-circuit overcurrent device, shall be provided. Controls shall include text or an icon indicating the system's function.*

*Exception: For multifamily dwelling units, the manual ON-OFF control shall not be required to be readily accessible.*

*From Standards Section 150.0(o)11: Compliance with ASHRAE 62.2 Section 4.4 (Control and Operation) shall require manual switches associated with dwelling unit ventilation systems to have a label clearly displaying the following text, or equivalent text: "This switch controls the indoor air quality ventilation for the home. Leave it on unless the outdoor air quality is very poor."*

ASHRAE 62.2 requires that the ventilation system have an override control that is accessible to the occupants. The control must be capable of being accessed quickly and easily by the occupants. It can be a labeled wall switch or a circuit breaker located in the electrical panel, or it may be integrated into a labeled wall-mounted control. It cannot be buried in the insulation in the attic or inside the installed ventilation fan cabinet. The occupant must have easy access to modify the fan control settings or turn off the system, if necessary.

For multifamily dwelling units, the manual ON-OFF control is not required to be readily accessible to the dwelling unit occupant(s). Instead, the ventilation control may be located such that it is readily accessible to the person in charge of the multifamily building maintenance. This control strategy may be appropriate for multifamily buildings that use unbalanced (supply-only or exhaust-only) system types for which the Energy Standards require that all the ventilation systems in the building operate continuously. Continuous operation of all ventilation fans in the building tends to minimize ventilation fan-induced pressure differences between adjoining dwellings, thus reducing the leakage of transfer air between dwelling units. Transfer airflows that originate in one dwelling unit may adversely affect the indoor air quality of the other dwelling units in the building if the transfer air contains pollutants such as tobacco smoke and PM<sub>2.5</sub> from kitchen range cooking.

Dwelling unit ventilation systems may operate continuously, or if fan operation is not continuous, the average ventilation rate over any three-hour period must be greater than or equal to the minimum dwelling unit ventilation rate calculated as described in Section 4.6.5 above.

Bathroom exhaust fans may serve a dual purpose to provide whole-dwelling unit ventilation operating at a low constant airflow rate and to provide local demand controlled ventilation at a higher "boost" airflow rate, when needed. For these system types, the continuous whole-dwelling unit airflow operation must have an ON/OFF override, which may be located in the bathroom or in a remote accessible location. The "boost" function is controlled by a separate wall switch located in the bathroom or by a motion sensor or humidistat located in the bathroom.

Time-of-day timers or duty-cycle timers can be used to control intermittent dwelling unit ventilation. Manual crank timers cannot be used, since the system must operate automatically without intervention by the occupant. Some controls "look back" over a set time interval to see if the CFI system air handler has already operated for heating or cooling before it turns on the air handler for ventilation-only operation.

See Section 4.6.4 for additional information about Energy Commission approval of ventilation controls.

#### Example 4-17 – Control Options

**Question:**

A bathroom exhaust fan is used to provide dwelling unit ventilation for a house. The fan is designed to be operated by a typical wall switch. Is a label on the wall plate necessary to comply with the requirement that controls be "appropriately labeled"?

**Answer:**

Yes. Since the fan is providing the required dwelling unit ventilation, a label is needed to inform the occupant that this switch controls the indoor air quality ventilation for the home and directs the occupant to leave it on unless the outdoor air quality is very poor. If the exhaust fan were serving only the local exhaust requirement for the bathroom, then a label would not be required.

#### Example 4-18 – Thermostatic Control

**Question:**

Ventilation air is provided whenever the air handler operates via a duct run connecting the return side of the central air handler to the outdoors. The system is estimated to run on calls for heating and cooling about 40 percent of the time, averaged over the year. If it is assumed that the air handler runs only 25 percent of the time, and the airflow is sized accordingly, can the system be allowed to run under thermostatic control?

**Answer:**

No. A system under thermostatic control will go through periods with little or no operation when the outdoor temperature is near the indoor set point, or if the system is in setback mode. An intermittently operating ventilation system must be controlled by a timer that will cycle at least once every three hours to assure that adequate ventilation is provided regardless of outdoor conditions. Alternatively, a more complex control may be used if it complies with the requirements in ASSHRAE 62.2 Appendix C. These systems must be approved by the Energy Commission before being allowed for use for compliance with the required dwelling unit ventilation.

Cycle timer controls are available that keep track of when (and for how long) the system operates to satisfy heating/cooling requirements in the home. These controls turn on the central fan to provide additional ventilation air when heating/cooling operation of the central fan has not already operated for a long enough period to provide the required ventilation. When choosing cycle timer controls for compliance, it is necessary to use models that have been approved by the Energy Commission for use for compliance with dwelling unit mechanical ventilation.

---

#### **4.6.6 Dwelling Unit Mechanical Ventilation Energy Consumption**

For builders using the performance compliance approach, the energy use of fans (other than CFI fans) installed to meet the dwelling unit ventilation requirement is usually not an issue. The reason is the standard design W/CFM is set equal to the proposed design W/CFM up to an energy use level sufficient to accommodate most well-designed ventilation systems. Also, the standard design dwelling unit ventilation system airflow rate is set equal to the proposed design dwelling unit ventilation system airflow rate, so there is no energy penalty or credit for most systems. For balanced heat recovery or energy recovery ventilators (HRVs/ERVs), the HVI-rated recovery efficiency can be input to the performance compliance software to account for the heat recovery benefit, which helps offset higher fan energy use.

The fan efficacy of the central air handler used for a CFI ventilation system must conform to the same fan watt draw (W/CFM) limit as for cooling systems in all climate zones as verified by a HERS Rater in accordance with the diagnostic test protocols given in RA3.3. The RA3.3 verification of CFI systems determines the W/CFM of the total central system airflow, not the W/CFM of the ventilation airflow.

The Energy Standards do not regulate the energy use of ventilation fans installed for other purposes, such as local exhaust.

##### **4.6.6.1 Central Fan-Integrated Ventilation Systems – Watt Draw**

**§150.1(f)10**

CFI system automatic controls must operate the central system air handler fan (generally part of every hour of the year) to draw in and distribute ventilation air throughout the dwelling, even when there is no heating or cooling required. The Energy Standards prohibit CFI systems from operating continuously. Because the CFI ventilation control increases the central system air handler fan run time significantly, and because typical central system air handler fan and duct systems



require a large amount of power, a CFI ventilation system can use a large amount of electricity annually.

The fan efficacy of CFI systems must be verified using the same methods as required for furnaces and air handlers. (See Reference Residential Appendix RA3.3.) The central system air handler must be operating in ventilation mode with the outdoor air damper open and with ventilation air flowing into the return plenum from outside the building. Furthermore, the airflow that must be measured is the total airflow through the air handler (system airflow), which is the sum of the return airflow, and the outside air ducted to the return plenum (ventilation airflow). To pass the test, the watt draw must be less than or equal to 0.45 W/CFM for furnaces, and 0.58 W/CFM for air handlers that are not gas furnaces, or 0.62 W/CFM for small duct high velocity systems.

#### 4.6.6.2 Other Dwelling Unit Ventilation Systems – Watt Draw

There are no prescriptive or mandatory requirements for maximum fan energy (watt draw) for dwelling unit ventilation systems other than CFI systems.

When using the performance approach, you have the option of accepting the default minimum dwelling unit ventilation airflow rate and a watt draw value of 0.25 W/CFM, which is typical of continuous exhaust fans that meet the 1 sone requirement.

Otherwise, if the installed fan has a different airflow and fan efficacy, the actual airflow rate and fan watt draw of the fan must be input. Values for airflow and fan W/CFM information may be available from the HVI directory at the following URL.

[https://www.hvi.org/proddirectory/CPD\\_Reports/section\\_1/index.cfm](https://www.hvi.org/proddirectory/CPD_Reports/section_1/index.cfm)

If HVI does not list fan energy for the installed model, use information from the manufacturer's published documentation. When fan energy is listed as CFM/W instead of W/CFM, it is necessary to invert the value to provide W/CFM as input to the compliance software (for example: 4 CFM/ W = 1/4 W/CFM = 0.25 W/CFM). Installation of a dwelling unit ventilation system with a fan watt draw greater than 1.2 W/CFM of ventilation airflow will affect the results of the performance compliance calculation. Values less than 1.2 W/CFM are compliance-neutral (standard design = proposed design). The compliance software will simulate dwelling unit ventilation using the ventilation system CFM and W/CFM for the proposed design. If the builder specifies a system with heat recovery, he or she inputs the recovery efficiency of the proposed system, and the compliance software uses it in the proposed design to calculate the heat recovery effect of the dwelling unit ventilation. Ventilation heat recovery is never used in the standard design.

#### 4.6.7 Local Exhaust (Section 5 of ASHRAE 62.2)

*From ASHRAE 62.2,*

*5.1 Local Mechanical Exhaust. A local mechanical exhaust system shall be installed in each kitchen and bathroom. Nonenclosed kitchens shall be provided with a demand-controlled mechanical exhaust system meeting the requirements of Section 5.2. Each local ventilation system for all other kitchens and bathrooms shall be either one of the following two:*

- a. a demand-controlled mechanical exhaust system meeting the requirements of Section 5.2 or*
- b. a continuous mechanical exhaust system meeting the requirements of Section 5.3.*

*Exception: Alternative Ventilation. Other design methods may be used to provide the required exhaust rates when approved by a licensed design professional.*

*5.2 Demand-Controlled Mechanical Exhaust. A local mechanical exhaust system shall be designed to be operated as needed.*

*5.2.1 Control and Operation. Demand-controlled mechanical exhaust systems shall be provided with at least one of the following controls:*

- a. A readily accessible occupant-controlled ON-OFF control.*
- b. An automatic control that does not impede occupant ON control.*

*5.2.2 Ventilation Rate. The minimum airflow rating shall be at least the amount indicated in Table 5.1.*

*5.3 Continuous Mechanical Exhaust. A mechanical exhaust system shall be installed to operate continuously. The system may be part of a balanced mechanical system. See Chapter 10 of ASHRAE Guideline 24 for guidance on selection of methods.*

*5.3.1 Control and Operation. A readily accessible manual ON-OFF control shall be provided for each continuous mechanical exhaust system. The system shall be designed to operate during all occupiable hours.*

*Exception: For multifamily dwelling units, the manual ON-OFF control shall not be required to be readily accessible.*

*5.3.2 Ventilation Rate. The minimum delivered ventilation shall be at least the amount indicated in Table 5.2 during each hour of operation.*

**From ASHRAE 62.2 - Table 5-1 Demand-Controlled Local Ventilation Exhaust Airflow Rates.**

Application	Airflow
Enclosed Kitchen	<ul style="list-style-type: none"> <li>Vented range hood (including appliance-range hood combinations): 100 CFM (50 L/s)</li> <li>Other kitchen exhaust fans, including downdraft: 300 CFM (150 L/s) or a capacity of 5 ach</li> </ul>
Non-Enclosed Kitchen	<ul style="list-style-type: none"> <li>Vented range hood (including appliance-range hood combinations): 100 CFM (50 L/s)</li> <li>Other kitchen exhaust fans, including downdraft: 300 CFM (150 L/s)</li> </ul>
Bathroom	50 CFM (25 L/s)

**From ASHRAE 62.2 - TABLE 5.2 Continuous Local Ventilation Exhaust Airflow Rates**

Application	Airflow
Enclosed Kitchen	5 ACH, based on kitchen volume
Bathroom	20 CFM (10 L/s)

Local exhaust (sometimes called *spot ventilation*) has long been required for bathrooms and kitchens to remove moisture and odors at the source. Building codes have required an operable window or an exhaust fan in bathrooms for many years and have generally required kitchen exhaust either directly through a fan or indirectly through a recirculating range hood and an operable window. The Energy Standards recognize the limitations of these indirect methods of reducing moisture and odors and requires that these spaces be mechanically exhausted directly to outdoors, even if windows are present. Moisture condensation on indoor surfaces are a leading cause of mold and mildew in buildings. The occurrence of asthma is also associated with high interior relative humidity. Therefore, it is important to exhaust the excess moisture from bathing and cooking directly at the source.

The Energy Standards require that each kitchen and bathroom have an exhaust fan. Generally, this will be a dedicated exhaust fan in each room that requires local exhaust, although ventilation systems that exhaust air from multiple rooms using a duct system connected to a single exhaust fan are allowed as long as the minimum local exhaust requirement is met in all rooms served by the system. The standards define kitchens as any room containing cooking appliances, and bathrooms any room containing a bathtub, shower, spa, or other similar source of moisture. A room containing only a toilet is not required to have an exhaust fan; ASHRAE 62.2 assumes there is an adjacent bathroom with local exhaust.

Building codes may require that fans used for kitchen range hood exhaust ventilation be safety-rated by UL or some other testing agency for the particular location and/or application. Typically, these requirements address fire safety issues of fans placed

within an area defined by a set of lines at 45° outward and upward from the cooktop. Few bathroom exhaust fans will have this rating, so they cannot be used in these locations.

---

**Example 4-19 – Local Exhaust Required for Toilet**

**Question:**

I am building a house with 2½ baths. The half-bath consists of a room with a toilet and sink. Is local exhaust required for the half bath?

**Answer:**

No. Local exhaust is required only for bathrooms, which are defined by the Energy Standards as rooms with a bathtub, shower, spa or some other similar source of moisture. This does not include a simple sink for occasional hand washing.

**Example 4-20**

**Question:**

The master bath suite in a house has a bathroom with a shower, spa and sinks. The toilet is in a separate, adjacent room with a full door. Where do I need to install local exhaust fans?

**Answer:**

The standards require local exhaust only in the bathroom, not the separate toilet room.

---

**4.6.7.1 Demand-Controlled (Intermittent) Local Exhaust**

The Energy Standards require that local exhaust fans be designed to be operated by the occupant. This usually means that a wall switch or some other control is accessible and obvious. There is no requirement to specify where the control or switch needs to be located, but bathroom exhaust fan controls are generally located next to the light switch, and kitchen exhaust fan controls are generally integrated into the range hood or mounted on the wall or counter adjacent to the range hood.

Bathrooms can use a variety of exhaust strategies. They can use ceiling-mounted exhaust fans or may use a remotely mounted fan ducted to two or more exhaust grilles. Demand-controlled local exhaust can be integrated with the dwelling unit ventilation system to provide both functions. Kitchens can have range hood exhaust fans, down-draft exhausts, ceiling- or wall-mounted exhaust fans, or pickups for remote-mounted inline exhaust fans. Generally, HRV/ERV manufacturers do not allow exhaust ducting from the kitchen because of the heat, moisture, grease, and particulates that should not enter the heat exchange core. Building codes require kitchen exhaust fans to be connected to metal ductwork for fire safety.

---

**Example 4-21 – Ducting Kitchen Exhaust to the Outdoors****Question:**

How do I know what kind of duct I need to use? I've been using recirculating hoods my entire career, now I need to vent to the outdoors. How do I do it?

**Answer:**

A kitchen range hood or downdraft duct is generally a smooth metal duct that is sized to match the outlet of the ventilation device. It is often a six-inch or seven-inch-round duct, or the range hood may have a rectangular discharge. If it is rectangular, the fan will typically have a rectangular-to-round adapter included. Always use a terminal device on the roof or wall that is sized to be at least as large as the duct. Try to minimize the number of elbows used.

**Example 4-22****Question:**

How do I know what the requirements are in my area?

**Answer:**

Ask your code enforcement agency for that information. Some enforcement agencies will accept metal flex; some will not.

---

**A. Control and Operation for Intermittent Local Exhaust**

The choice of control is left to the designer. It can be a manual switch or automatic control like an occupancy sensor. Some exhaust fans have multiple speeds, and some fan controls have a delay-off function that operates the exhaust fan for a set time after the occupant leaves the bathroom. New control strategies continue to come to the market. The only requirement is that there is a control. Title 24, Part 11 may specify additional requirements for the control and operation of intermittent local exhaust.

**B. Ventilation Rate for Demand-Controlled Local Exhaust**

A minimum exhaust airflow of 100 CFM is required for vented kitchen range hoods, and 300 CFM or 5 ACH is required for other kitchen exhaust fans. A minimum exhaust airflow of 50 CFM is required for bathroom fans.

The 100 CFM requirement for the range hood or microwave/hood combination is the minimum to adequately capture the moisture, particulates, and other products of cooking and/or combustion. Only in kitchens that are enclosed, the exhaust requirement can also be met with either a ceiling or wall-mounted exhaust fan or with a ducted fan or ducted ventilation system that can provide at least five air changes of the kitchen volume per hour. Recirculating range hoods that do not exhaust pollutants to the outside cannot be used to meet the requirements of ASHRAE Standard 62.2 unless paired with an exhaust system that can provide at least five air changes of the kitchen volume per hour.

The 2019 Title 24 Part 6 standards require verification that range hoods are HVI-certified to provide at least one speed setting at which they can deliver at least 100 CFM at a noise level of 3 sones or less. Verification must be in accordance with the procedures in *Reference Residential Appendix RA3.7.4.3*. Range hoods that have a minimum airflow setting exceeding 400 CFM are exempt from the noise requirement. HVI listings are available at:

[https://www.hvi.org/proddirectory/CPD\\_Reports/section\\_1/index.cfm](https://www.hvi.org/proddirectory/CPD_Reports/section_1/index.cfm)

ASHRAE Standard 62.2 limits exhaust airflow when atmospherically vented combustion appliances are located inside the pressure boundary. This is particularly important to observe when large range hoods are installed. Refer to Section 4.6.8.4 below for more information.

---

**Example 4-23 – Ceiling or Wall Exhaust vs Demand-Controlled Range Hood in an Enclosed Kitchen**

**Question:**

I am building a house with an enclosed kitchen that is 12 ft. x 14 ft. with a 10 ft. ceiling. What size ceiling exhaust fan or range hood fan is required?

**Answer:**

If a range hood exhaust is not used, either 300 CFM or 5 ACH minimum airflow is required. The kitchen volume is 12 ft. x 14 ft. x 10 ft. = 1,680 ft<sup>3</sup>. Five air changes are a flow rate of 1,680 ft<sup>3</sup> x 5/ hr. ÷ 60 min/hr = 140 CFM. So, this kitchen must have a ceiling or wall exhaust fan of 140 CFM. Otherwise, a vented range hood fan that provides at least 100 CFM is required.

---

#### 4.6.7.2 Continuous Local Exhaust

The Energy Standards allow the designer to install a local exhaust system that operates without occupant intervention continuously and automatically during all occupiable hours. Continuous local exhaust is generally specified when the local exhaust ventilation system is combined with a continuous dwelling unit ventilation system. For example, if the dwelling unit ventilation is provided by a continuously operating exhaust fan located in the bathroom, this fan may also satisfy the local exhaust requirement for that bathroom, provided the fan provides airflow greater than or equal to the minimum continuous local ventilation airflow rate. Continuous local exhaust may also be part of a pickup, or an interior grille, for a remote fan or HRV/ERV system.

Continuously operating bathroom fans must operate at a minimum of 20 CFM. Continuously operating kitchen fans are permitted only for enclosed kitchens. Refer to Tables 5.1 and 5.2 in ASHRAE 62.2 for other local demand controlled and continuous exhaust requirements.

---

**Example 4-24 – Continuous Kitchen Exhaust**

**Question:**

A new house has an open-design, 12 ft. x18 ft. ranch kitchen with 12 ft. cathedral ceilings. What airflow rate will be required for a continuous exhaust fan?

**Answer:**

A continuous exhaust fan cannot be used in nonenclosed kitchens. A vented range hood must be provided.

#### 4.6.8 Other Requirements (Section 6 of ASHRAE 62.2)

##### 4.6.8.1 Adjacent Spaces and Transfer Air

*From ASHRAE 62.2,*

*6.1 Adjacent Spaces and Transfer Air. Measures shall be taken to minimize air movement across envelope components to dwelling units from adjacent spaces such as garages, unconditioned crawlspaces, unconditioned attics, and other dwelling units. Pressure boundary wall, ceiling, and floor penetrations shall be sealed, as shall any vertical chases adjacent to dwelling units. Doors between dwelling units and common hallways shall be gasketed or made substantially airtight.*

*Supply and balanced ventilation systems shall be designed and constructed to provide ventilation air directly from the outdoors.*

*6.1.1 Compliance for Attached Dwelling Units. One method of demonstrating compliance with Section 6.1 shall be to verify a leakage rate below a maximum of 0.3 CFM per ft<sup>2</sup> (150 L/s per 100 m<sup>2</sup>) of the dwelling unit envelope area (i.e., the sum of the area of walls between dwelling units, exterior walls, ceiling, and floor) at a test pressure of 50 Pa by a blower door test conducted in accordance with either ANSI/ASTM-E779 or ANSI/ASTM-E1827. The test shall be conducted with the dwelling unit as if it were exposed to outdoor air on all sides, top, and bottom by opening doors and windows of adjacent dwelling units.*

ASHRAE Standard 62.2 requires that the air used for ventilation come from the outdoors. Air may not be drawn in as transfer air from other spaces that are outside the occupiable space of the dwelling unit, or from between dwelling units and corridors. This is to prevent airborne pollutants originating in those other spaces from contaminating the dwelling unit. For example, drawing ventilation air from the garage could introduce VOCs or pesticides into the indoor air. Drawing ventilation air from an unconditioned crawlspace could cause elevated allergen concentrations in the dwelling such as mold spores, insects, or rodent allergens. Likewise, drawing air from an adjacent dwelling could introduce unwanted contaminants such as cooking odors or cigarette smoke.

Standards Section 150.0(o)1E requires HERS verification compliance with a maximum of 0.3 CFM/ft<sup>2</sup> dwelling unit enclosure leakage when either supply ventilation is used or exhaust ventilation is used. The protocol for the blower door test is given in Reference Residential Appendix RA3.8. See also Section 4.6.3.2 in

this chapter for more information about multifamily dwelling unit compartmentalization.

In addition to designing the ventilation system to draw air from the outdoors, the standard also requires that measures be taken to prevent air movement between adjacent dwelling units and between the dwelling unit and other nearby spaces, such as garages. The measures can include air sealing of envelope components, pressure management, and use of airtight recessed light fixtures. The measures must apply to adjacent units above and below, as well as side by side.

Air sealing must include pathways in vertical components such as demising walls and walls common to the unit and an attached garage, and in horizontal components such as floors and ceilings. Pipe and electrical penetrations are examples of pathways that require sealing.

#### 4.6.8.2 Instructions and Labeling

*From ASHRAE 62.2, Section 6.2, Instructions and Labeling.*

*Information on the ventilation design and/or ventilation systems installed, instructions on their proper operation to meet the requirements of this standard, and instructions detailing any required maintenance (similar to that provided for HVAC systems) shall be provided to the owner and the occupant of the dwelling unit. Controls shall be labeled as to their function (unless that function is obvious, such as toilet exhaust fan switches).*

*From Standards Section 150.0(o)11:*

*Compliance with ASHRAE 62.2 Section 4.4 (Control and Operation) shall require manual switches associated with dwelling unit ventilation systems to have a label clearly displaying the following text, or equivalent text: "This switch controls the indoor air quality ventilation for the home. Leave it on unless the outdoor air quality is very poor."*

Field studies have shown that switches for exhaust fans do not have the required labels, and that many homeowners do not understand the importance of continuous operation of the ventilation fans for maintaining indoor air quality. Standards Section 10-103(b)4 require the builder to leave in the building, for the building owner at occupancy, a description of the quantities of outdoor air that the ventilation system(s) are designed to provide to the conditioned space of the building and instructions for proper operation and maintenance of the ventilation system.

Because the concept of a designed dwelling unit ventilation system may be new to many occupants, the standards section requires that ventilation system controls be labeled as to function. One acceptable option is to affix a label to the electrical panel that provides some basic system operation information.



#### 4.6.8.3 Clothes Dryers

*From ASHRAE 62.2, Section 6.3, Clothes Dryers.*

*Clothes dryers shall be exhausted directly to the outdoors. Exception: Condensing dryers plumbed to a drain.*

All laundry rooms must be built with a duct to the outdoors, designed to be connected to the dryer. Devices that allow the exhaust air to be diverted into the indoor space to provide extra heating are not permitted. This requirement is consistent with existing clothes dryer installation and design standards.

In multifamily buildings, multiple dryer exhaust ducts can be connected to a common exhaust only when dampers are provided to prevent recirculation of exhaust air from one apartment to another.

#### Example 4-25 – Clothes Dryer Exhaust Diverter

##### **Question:**

I am building a home that has been purchased prior to completion. The buyer has asked for an exhaust air diverter to be installed in the dryer exhaust duct. He says that it is wasteful of heating energy to exhaust the warm humid air to the outdoors during the winter when the furnace and humidifier are working. He says that the screen on the diverter will prevent excess dust being released into the space. Can I install the device for him?

##### **Answer:**

If you do, you will not comply with the Energy Standards. The device is specifically prohibited. Significant amounts of dust are released from such devices, and the moisture in the dryer exhaust can lead to humidity problems as well, particularly in warmer climates.

#### 4.6.8.4 Combustion and Solid-Fuel Burning Appliances

*From ASHRAE 62.2, Section 6.4, Combustion and Solid-Fuel Burning Appliances*

*6.4.1 Combustion and solid-fuel burning appliances must be provided with adequate combustion and ventilation air and installed in accordance with manufacturers' installation instructions; NFPA 54/ANSI Z223.1, National Fuel Gas Code<sup>5</sup>; NFPA 31, Standard for the Installation of Oil-Burning Equipment<sup>6</sup>; or NFPA 211, Standard for Chimneys, Fireplaces, Vents, and Solid-Fuel Burning Appliances,<sup>7</sup> or other equivalent code acceptable to the building official.*

*6.4.2 Where atmospherically vented combustion appliances or solid-fuel burning appliances are located inside the pressure boundary, the total net exhaust flow of the two largest exhaust fans (not including a summer cooling fan intended to be operated only when windows or other air inlets are open) shall not exceed 15 CFM per 100 ft<sup>2</sup> (75 L/s per 100 m<sup>2</sup>) of occupiable space when in operation at full capacity. If the designed total net*

*flow exceeds this limit, the net exhaust flow must be reduced by reducing the exhaust flow or providing compensating outdoor air. Gravity or barometric dampers in nonpowered exhaust makeup air systems shall not be used to provide compensating outdoor air. Atmospherically vented combustion appliances do not include direct-vent appliances. Combustion appliances that pass safety testing performed according to ANSI/BPI-1200, Standard Practice for Basic Analysis of Buildings, shall be deemed as complying with Section 6.4.2.*

ASHRAE Standard 62.2 requires that the vent system for combustion appliances be properly installed, as specified by the instructions from the appliance manufacturer and by the California Building Code. Compliance with the venting requirements will involve determining the type of vent material to be used, the sizing of the vent system, and vent routing requirements.

ASHRAE Standard 62.2 includes a provision intended to prevent back drafting, where one or more large exhaust fans are installed in a home with atmospherically vented or solid fuel appliances. If the two largest exhaust fans have a combined capacity that exceeds 15 CFM/100 ft<sup>2</sup> of floor area, then makeup air must be provided. This provision applies only when the atmospherically vented appliance is inside the pressure boundary of the house and does not include a summer cooling fan that is designed to be operated with the windows open. Direct-vent appliances are not considered “atmospherically vented.”

The two largest exhaust fans are normally the kitchen range hood and the clothes dryer (if located inside the dwelling unit pressure boundary). Large-range hoods, particularly downdraft range hoods, can have capacities of 1,000 CFM or more.

A problem with this requirement can be solved in one of three ways. First, all atmospherically vented combustion appliances can be moved outside the pressure boundary of the house (to the garage or other similar space). Second, the flow rate of one or more of the fans can be reduced so that the combined flow is less than 15 CFM/100 ft<sup>2</sup>. Finally, makeup air can be provided to offset the net exhaust rate.

#### Example 4-26 – Large Exhaust Fan

##### **Question:**

I am building a 3,600 ft<sup>2</sup> custom home that has four bedrooms. The kitchen will have a high-end range hood that has three speeds, nominally 1,000 CFM, 1,400 CFM and 1,600 CFM. The house will include an atmospherically vented gas water heater located in the basement. If I am using a central exhaust fan for the dwelling unit ventilation of 75 CFM, and there is a clothes dryer installed, how much compensating outdoor airflow (makeup air) is needed?

##### **Answer:**

You must use the high-speed value for the range hood of 1,600 CFM. The clothes dryer will have a flow that is assumed to be 150 CFM for sizing purposes. These two flows must be added together for a total exhaust capacity of 1,750 CFM. Since the dwelling unit ventilation fan is not one of the two largest exhaust fans, it does not figure into the makeup air calculation. Using the equation above, there must be at least 1,750 CFM –  $(15 \text{ CFM} \times 3,600 \text{ ft}^2 / 100 \text{ ft}^2) = 1,210 \text{ CFM}$  of makeup airflow.

#### Example 4-27

**Question:**

The same custom house will have the water heater located in the garage instead of the basement. Does that change anything?

**Answer:**

Garages (and attics) are normally located outside the pressure boundary, so makeup air is not required. If the garage is inside the pressure boundary, makeup air is required, and the answer would be the same as 4-24.

#### Example 4-28

**Question:**

For this house, I need to keep the water heater in the basement. What are my options that would avoid the requirement to provide makeup air?

**Answer:**

There are several things you could do. First, you could use a direct vent water heater that would also provide higher fuel efficiency. You could use a lower capacity range hood, one that is less than 390 CFM ( $15 \text{ CFM} \times 3,600 \text{ ft}^2 / 100 \text{ ft}^2 - 150 \text{ CFM}$ ). Use of supply-only dwelling unit ventilation would allow the hood capacity to increase to 465 CFM ( $15 \text{ CFM} \times 3,600 \text{ ft}^2 / 100 \text{ ft}^2 - 150 \text{ CFM} + 75 \text{ CFM}$ ). There are also range hoods available in the commercial market that provide makeup air.

#### 4.6.8.5 Garages

*From ASHRAE 62.2, Section 6.5.1, Garages.*

*When an occupiable space adjoins a garage, the design must prevent migration of contaminants to the adjoining occupiable space. Air seal the walls, ceilings, and floors that separate garages from occupiable space. To be considered air-sealed, all joints, seams, penetrations, openings between door assemblies and their respective jambs and framing, and other sources of air leakage through wall and ceiling assemblies separating the garage from the residence and its attic area shall be caulked, gasketed, weather stripped, wrapped, or otherwise sealed to limit air movement. Doors between garages and occupiable spaces shall be gasketed or made substantially airtight with weather stripping.*

Garages often contain numerous sources of contaminants. These include vehicle exhaust, gasoline, pesticides, paints and solvents, and others. The Energy Standards require that when garages are attached to the house, these contaminants be prevented from entering the house. The wall between the unit and garage (or garage ceiling in designs with living space above garages) shall be designed and constructed so that no air migrates through the wall or ceiling. The common doors and any air handlers or ducts located in the garage shall also be sealed, weatherstripped, or gasketed.

Standards Section 150.0(o) specifies that compliance with ASHRAE 62.2 Section 6.5.2 (Space Conditioning System Ducts) shall not be required. However, the applicable duct leakage verification requirements are given in Standards Sections 150.0(m)11 for newly constructed buildings, and 150.2(b)1D for alterations to systems in existing buildings. All ducted space conditioning systems in newly constructed buildings are required to pass HERS verification that duct system leaks are less than or equal to 5 percent of the system airflow rate. This requirement applies to portions of the system that may be in a garage space.

For alterations to space conditioning systems in existing buildings that have all or portions of the forced air ducts, plenums or air-handling units in the garage, Section 150.2(b)1D specifies two compliance approaches:

1. The measured system duct leakage shall be less than or equal to 6 percent of system air handler airflow as determined using the procedures in Reference Residential Appendix Section RA3.1.4.3.1.
2. All accessible leaks located in the garage space shall be sealed and verified through a visual inspection and a smoke test by a certified HERS Rater using the methods specified in Reference Residential Appendix RA3.1.4.3.5.

For additions and alterations to existing buildings, any length of new or altered duct located in the garage or any new or altered air-handling unit located in the garage triggers these duct leakage testing requirements.

---

#### Example 4-29 – Garages

**Question:**

In a newly constructed building, the building designer located the air handler in the garage. The main return trunk from the dwelling is connected to the air handler. Is this acceptable?

**Answer:**

Yes. The duct system must be leak-tested and sealed, if necessary, to have leakage no greater than 5 percent of the total fan flow.

#### Example 4-30

**Question:**

For an alteration to an existing building, the air handler is located in the dwelling unit, and a portion of the return duct is run through the garage to a bedroom above the garage. The return duct has 4 feet of length located in the garage, and this 4-foot section is being replaced. How do I test that length of the duct for leakage?

**Answer:**

First, test the leakage for the entire duct system to determine whether the total system duct leakage is no greater than 6 percent of the total fan flow. If the system does not meet the 6 percent target for compliance, then use the visual inspection and smoke test specified in RA3.1.4.3.5 and seal all accessible leaks in the 4-foot section of duct that is in the garage space.

#### 4.6.8.6 Ventilation Opening Area

*From ASHRAE 62.2, Section 6.6 Ventilation Opening Area.*

*Spaces shall have ventilation openings as listed in the following subsections. Such openings shall meet the requirements of Section 6.8.*

*Exception: Attached dwelling units and spaces that meet the local ventilation requirements set for bathrooms in Section 5.*

*6.6.1 Habitable Spaces. Each habitable space shall be provided with ventilation openings with an openable area not less than 4% of the floor area or less than 5 ft<sup>2</sup> (0.5 m<sup>2</sup>).*

*6.6.2 Toilets and Utility Rooms. Toilets and utility rooms shall be provided with ventilation openings with an openable area not less than 4% of the room floor area or less than 1.5 ft<sup>2</sup> (0.15 m<sup>2</sup>).*

*Exceptions:*

- 1. Utility rooms with a dryer exhaust duct.*
- 2. Toilet compartments in bathrooms.*

The dwelling unit mechanical ventilation is intended to provide adequate ventilation to typical new homes under normal circumstances. On occasion, however, houses experience unusual circumstances where high levels of contaminants are released into the space. When this occurs, a means of providing the significantly higher levels of ventilation required to remove the contaminants is needed. Operable windows are the most likely means of providing the additional ventilation.

This section of ASHRAE Standard 62.2 requires ventilation openings in habitable spaces, toilets, and utility rooms. Ventilation openings usually mean operable windows, although a dedicated nonwindow opening for ventilation is acceptable. Spaces that meet the local exhaust requirements are exempted from this requirement.

#### 4.6.8.7 Habitable Spaces

Habitable spaces are required to have ventilation openings with openable area equal to at least 4 percent of the space floor area (but not less than 5 ft<sup>2</sup>). Dining rooms,

living rooms, family rooms, bedrooms, and kitchens are considered habitable space. Closets, crawl spaces, garages, and utility rooms are generally not. If the washer and dryer are located in an open basement that is also the family room, it would be considered habitable space.

The openings do not have to be provided by windows. They can also be provided by operable, insulated, weather-stripped panels.

Ventilation openings, which include operable windows, skylights, through-the-wall vents, window vents, or similar devices, shall be readily accessible to the occupant. This means that the occupant must be able to operate the opening without having to climb on anything. An operable skylight must have some means of being operated while standing on the floor: a push rod, a long crank handle, or an electric motor.

If a ventilation opening is covered with louvers or otherwise obstructed, the operable area is the unobstructed free area through the opening.

---

#### Example 4-31 – Ventilation Openings

**Question:**

I am building a house with a 14 ft. by 12 ft. bedroom. What size window do I need to install?

**Answer:**

It depends on the type of window. The standard requires that the operable area of the window, not the window unit, be 4 percent of the floor area, or  $14 \text{ ft} \times 12 \text{ ft} \times 0.04 = 6.7 \text{ ft}^2$ . The fully opened area of the window or windows must be greater than  $6.7 \text{ ft}^2$ . The requirement for this example can be met using two double-hung windows, each with a fully opened area of  $3.35 \text{ ft}^2$ . Any combination of windows whose opened areas add up to at least  $6.7 \text{ ft}^2$  will meet the requirement.

#### Example 432 – Ventilation Opening Louvers

**Question:**

There are fixed wooden louvers over a window in a bedroom. The louvers have slats that are 1/8-in thick, and they are spaced 1 inch apart. What is the reduction in operable area?

**Answer:**

Assuming that the 1-inch spacing was measured perpendicular to the slats (the correct way), then the reduction is the slat thickness divided by the spacing, or 1/8 inch. So the credited opening area is the original opening area  $\times (1 \text{ inch} - 1/8 \text{ inch})/1 \text{ inch} = 7/8$  of the original opening area.

---

#### 4.6.8.8 Minimum Filtration

Compliance with ASHRAE 62.2 Sections 6.7 (Minimum Filtration) and 6.7.1 (Filter Pressure Drop) are not be required (Standards Section 150.0(o)1D). However, air

filtration for mechanical systems must conform to the specifications in Standards Section 150.0(m)12. Information on air filtration requirements is given in Section 4.4.1.14 of this chapter.

#### 4.6.8.9 Air Inlets

*From ASHRAE 62.2, Section 6.8, Air Inlets.*

*Air inlets that are part of the ventilation design shall be located a minimum of 10 ft (3 m) from known sources of contamination such as a stack, vent, exhaust hood, or vehicle exhaust. The intake shall be placed so that entering air is not obstructed by snow, plantings, or other material. Forced air inlets shall be provided with rodent/insect screens (mesh not larger than 1/2 in. [13 mm]).*

*Exceptions:*

- 1. Ventilation openings in the wall may be as close as a stretched-string distance of 3 ft (1 m) from sources of contamination exiting through the roof or dryer exhausts.*
- 2. No minimum separation distance shall be required between windows and local exhaust outlets in kitchens and bathrooms.*
- 3. Vent terminations covered by and meeting the requirements of the National Fuel Gas Code (NFPA 54/ANSI Z223.1)7 or equivalent.*
- 4. Where a combined exhaust/intake termination is used to separate intake air from exhaust air originating in a living space other than kitchens, no minimum separation distance between these two openings is required. For these combined terminations, the exhaust air concentration within the intake airflow shall not exceed 10%, as established by the manufacturer.*

##### *6.8.1 Ventilation Openings.*

*Operable windows, skylights, through-the-wall inlets, window air inlets, or similar devices shall be readily accessible to occupants. Where openings are covered with louvers or otherwise obstructed, openable area shall be based on the free, unobstructed area through the opening.*

When the ventilation system is designed with air inlets, the inlets must be located away from locations that can be expected to be sources of contamination. The minimum separation is 10 ft. Inlets include not only inlets to ducts, but windows that are needed to the opening area.

The Energy Standards list some likely sources of contaminants. For typical residential applications, the sources will include:

1. Vents from combustion appliances.
2. Chimneys.
3. Exhaust fan outlets.
4. Barbeque grills.

5. Locations where vehicles may be idling for any significant length of time.
6. Any other locations where contaminants will be generated.

The Energy Standards also require that air intakes be placed so that they will not become obstructed by snow, plants, or other material. Forced air inlets must also be equipped with insect/rodent screens, where the mesh is no larger than 1/2 inch.

#### **4.6.9 Air-Moving Equipment (Section 7 of ASHRAE 62.2)**

*From ASHRAE 62.2, Section 7.1, Selection and Installation.*

*Ventilation devices and equipment serving individual dwelling units shall be tested in accordance with ANSI/ASHRAE Standard 51/AMCA 210, Laboratory Methods of Testing Fans for Aerodynamic Performance Rating, and ANSI/AMCA Standard 300, Reverberant Room Method for Sound Testing of Fans, and rated in accordance with the airflow and sound rating procedures of the Home Ventilating Institute (HVI) (HVI 915, Loudness Testing and Rating Procedure; HVI 916, Air Flow Test Procedure; and HVI 920, Product Performance Certification Procedure Including Verification and Challenge). Installations of systems or equipment shall be carried out in accordance with manufacturers' design requirements and installation instructions.*

Equipment used to meet the dwelling unit ventilation requirements or the local exhaust ventilation requirements shall be rated to deliver the required airflow and shall have sound ratings that meet the requirements of this section.

##### **4.6.9.1 Selection and Installation**

ASHRAE Standard 62.2 requires that equipment used to comply with the standard be selected based on tested and certified ratings of performance for airflow and sound. When selecting fans for use in meeting the requirements of the standard, you must check the Home Ventilating Institute (HVI) Certified Products Directory to confirm that the equipment you select has been tested and the rated performance meets the requirements. The *HVI-Certified Products Directory* can be viewed at the following URL:

<http://www.hvi.org/proddirectory/index.cfm>.

In addition, the Energy Standards require that the fans be installed in accordance with the manufacturer's instructions. You must review the installation instructions and other literature shipped with the fan and make sure that the installation complies with those instructions.

##### **4.6.9.2 Sound Ratings for Fans**

*From ASHRAE 62.2, Section 7.2, Sound Ratings for Fans.*

*Ventilation fans shall be rated for sound at no less than the minimum airflow rate required by this standard as noted below. These sound ratings shall be at a minimum of 0.1 in. wc (25 Pa) static pressure in accordance with the*



*HVI procedures referenced in Section 7.1.*

*Exception: HVAC air handlers and remote mounted fans need not meet sound requirements. To be considered for this exception, a remote mounted fan must be mounted outside the habitable spaces, bathrooms, toilets, and hallways, and there must be at least 4 ft (1 m) of ductwork between the fan and the intake grille.*

*7.2.1 Dwelling-Unit Ventilation or Continuous Local Exhaust Fans. These fans shall be rated for sound at a maximum of 1.0 sone.*

*7.2.2 Demand-Controlled Local Exhaust Fans. Bathroom exhaust fans used to comply with Section 5.2 shall be rated for sound at a maximum of 3 sonas. Kitchen exhaust fans used to comply with Section 5.2 shall be rated for sound at a maximum of 3 sonas at one or more airflow settings greater than or equal to 100 CFM (47 L/s).*

*Exception: Fans with a minimum airflow setting exceeding 400 CFM (189 L/s) need not comply.*

Standards Section 150.0(o)1G requires kitchen range hoods to be rated for sound in accordance with Section 7.2 of ASHRAE 62.2 and provides an exception to allow kitchen range hoods to be rated for sound at a static pressure determined at working speed as specified in HVI 916 Section 7.2. The static pressure at working speed may be lower than 0.1 inch w.c.

One common reason ventilation equipment may not be operated by dwelling unit occupants, particularly local exhaust fans, is the noise the fans may create. To address this, ASHRAE Standard 62.2 requires that certain fans be rated for sound and that installed fans shall have ratings below specified limits. The sound rating must be done at an airflow that is no less than the airflow that the fan must provide to meet the ventilation airflow requirement.

Because of the variables in length and type of duct and grille, there is no clearly repeatable way to specify a sound level for ventilation devices that are not mounted in the ceiling or wall surface. Consequently, air handlers, HRV/ERVs, inline fans, and remote fans are exempted from the sound rating requirements that apply to surface-mounted fans. However, to reduce the amount of fan and/or motor noise that could come down the duct to the grille, the Energy Standards sets a minimum of 4 feet of ductwork between the grille and the ventilation device. This may still produce an undesirable amount of noise for the occupant, especially if hard metal duct is used. Flexible insulated duct or a sound attenuator will reduce the transmitted sound into the space.

#### **A. Continuous Ventilation Fans (Surface-Mounted Fans)**

Continuously operated fans shall be rated at 1.0 sone or less. This 1.0 sone requirement applies to continuous dwelling unit ventilation fans and to continuous local exhaust ventilation fans.

## **B. Intermittent or Demand Controlled Fans (Surface-Mounted Fans)**

Intermittently operated dwelling unit ventilation fans shall be rated at a maximum of 1.0 sone. Demand-controlled local exhaust fans shall be rated at a maximum of 3.0 sones, unless the maximum rated airflow is greater than 400 CFM.

ASHRAE Standard 62.2 extends the requirement for quiet fans to include range hoods and bath exhaust fans, not just dwelling unit ventilation system fans. Dwelling unit ventilation fans or systems that operate continuously must be rated 1.0 sone or less, but demand-controlled local exhaust fans, including demand-controlled bathroom fans, must be 3.0 sones or less. Range hood exhaust fans must also be rated at 3.0 sones or less at the minimum required speed of 100 CFM.

### **4.6.9.3 Airflow Measurements and Airflow Ratings**

*From ASHRAE 62.2.*

*4.3 Airflow Measurement. The airflow required by this section is the quantity of outdoor ventilation air supplied and/or indoor air exhausted by the mechanical ventilation system as installed and shall be measured according to the ventilation equipment manufacturer's instructions, or by using a flow hood, flow grid, or other airflow measuring device at the mechanical ventilation fan's inlet terminals/grilles, outlet terminals/grilles, or in the connected ventilation ducts. Ventilation airflow of systems with multiple operating modes shall be tested in all modes designed to meet this section.*

*5.4 Airflow Measurement. The airflow required by this section is the quantity of indoor air exhausted by the ventilation system as installed and shall be measured according to the ventilation equipment manufacturer's instructions, or by using a flow hood, flow grid, or other airflow measuring device at the mechanical ventilation fan's inlet terminals, outlet terminals, or in the connected ventilation ducts.*

*Exception: The airflow rating, according to Section 7.1, at a pressure of 0.25 in. wc (62.5 Pa) may be used, provided the duct sizing meets the prescriptive requirements of Table 5.3 or manufacturer's design criteria.*

All dwelling unit ventilation systems must demonstrate compliance by direct measurement of airflow using a flow hood, flow grid, or other approved measuring device. HERS verification of dwelling unit ventilation airflow is required for newly constructed buildings and existing buildings with additions greater than 1,000 square feet or an increase in the number of dwelling units.

There are two ways to demonstrate compliance with airflow requirements for local exhaust ventilation:

1. Test the ventilation system using an airflow measuring device after completion of the installation to confirm that the delivered ventilation airflow meets the requirement.

2. Conformance to a prescriptive requirement that the fan has a certified airflow rating that meets or exceeds the required ventilation airflow, and ventilation ducts meet either the fan manufacturer’s published duct design specifications or the prescriptive duct design requirements given in Table 4-16 (Table 5.3 of ASHRAE 62.2).

When using the prescriptive duct sizing table or manufacturer's design criteria for compliance, the certified airflow rating of the fan must be based on tested performance at the 0.25 inches water column (w.c.) static pressure. The airflow rating of a fan is available from the Home Ventilating Institute (HVI) Certified Products Directory at the HVI website ([www.hvi.org](http://www.hvi.org)).

If the manufacturer's duct system design specifications are used for compliance, the enforcement agency may require that the manufacturer's published system design documentation be provided for use for inspection of the installation(s).

The prescriptive duct design criteria given in Table 4-15 provide maximum exhaust duct lengths based on duct type and diameter. The higher the airflow, the larger in diameter or shorter in length the duct must be. Smooth duct can be used to manage longer duct runs. Interpolation and extrapolation of Table 4-15 are not allowed. For airflow rates not listed, use the next higher value. The table is not applicable for systems with airflow greater than 125 CFM at 62 Pa (0.25 inches water column) static pressure.

**Table 4-15: Prescriptive Duct Sizing for Single-Fan Exhaust Systems**  
(ASHRAE 62.2, Table 5.3)

Duct Type	Flex Duct								Smooth Duct							
Fan Airflow CFM @ 0.25 in. (L/s @ 62.5 Pa)	50	80	100	125	150	200	250	300	50	80	100	125	150	200	250	300
	(25)	(40)	(50)	(65)	(75)	(100)	(125)	(150)	(25)	(40)	(50)	(65)	(75)	(100)	(125)	(150)
Diameter <sup>a</sup> , in.	Maximum Length <sup>b,c,d</sup> , ft (m)															
3 (75)	x	x	x	x	x	x	x	x	5 (2)	x	x	x	x	x	x	x
4 (100)	56 (17)	4 (1)	x	x	x	x	x	x	114 (35)	31 (9)	10 (3)	x	x	x	x	x
5 (125)	NL	81 (25)	42 (9)	16 (5)	2 (0.6)	x	x	x	NL	152 (46)	91 (28)	51 (16)	28 (9)	4 (1)	x	x
6 (150)	NL	NL	158 (48)	91 (28)	55 (17)	18 (5)	1 (0.3)	x	NL	NL	NL	168 (51)	112 (34)	53 (16)	25 (8)	9 (3)
7 (175)	NL	NL	NL	NL	161 (49)	78 (24)	40 (12)	19 (6)	NL	NL	NL	NL	NL	148 (45)	88 (27)	54 (16)
8 (200) and above	NL	NL	NL	NL	NL	18 (5.8)	111 (34)	69 (21)	NL	NL	NL	NL	NL	NL	198 (60)	133 (41)

a. For noncircular ducts, calculate the diameter as four times the cross-sectional area divided by the perimeter.

b. This table assumes no elbows. Deduct 15 ft (5 m) of allowable duct length for each elbow.

c. NL = no limit on duct length of this size.

d. X = not allowed; any length of duct of this size with assumed turns and fitting will exceed the rated pressure drop.

---

#### Example 4-33 – Prescriptive Duct Sizing

**Question:**

I need to provide 75 CFM of continuous ventilation, which I plan to do using a central exhaust fan. I plan to connect the fan to a roof vent termination using flex duct. The duct will be about 8 feet long with no real elbows but some slight bends in the duct. What size duct do I need to use?

**Answer:**

From Table 4-15, using the 80 CFM, flex duct column, the maximum length with a 4-inch duct is 4 feet, so you cannot use 4 inches of duct. With a 5-inch duct, the maximum length is 81 feet, so that will clearly be adequate. Even if the bend in the duct is treated as an elbow, the allowable length only drops to 66 feet, more than adequate for the 8 feet required.

#### Example 4-34

**Question:**

For the situation in Example 4-30, again providing 75 CFM, what size duct would I need if smooth metal duct were used? In this case, the total length would increase to about 10 feet, and there would be two elbows.

**Answer:**

Using the 80 CFM, smooth duct column of Table 4-15, the maximum length of 4 inches duct is 31 feet. Subtracting 15 feet for each of the two elbows leaves 5 feet, which is not long enough. With a 5-inch duct, the maximum length is 152 feet. Subtracting 15 feet for each of the two elbows leaves 122 feet, so that will clearly be adequate.

#### Example 4-35

**Question:**

I will need a 100 CFM range hood. I have two possible duct routings. One is 15 feet long and will require three elbows. The other is 35 feet long but requires only one elbow. What size flex duct do I need to use?

**Answer:**

First, take the two routings and add in the correction for the elbows. Elbow corrections can be either added to the desired length or subtracted from the allowable length. In this case, we know the desired length, so we'll add the elbows. We get 15 feet plus 3 times 15 feet for a total of 60 feet, or 35 feet plus 15 feet equals 50 feet.

Looking at Table 4-15, in the 100 CFM, flex duct column, the maximum length with 5 inches duct is 42 feet, which is less than the adjusted length for either routing. With a 6-inch duct, the maximum length is 158 feet, longer than either adjusted length. A 6-inch duct would need to be used for either routing.

*Note:* The building code may not allow flex duct to be used for the range hood, in which case a smooth duct would be required. For a smooth duct, 5 inches would be acceptable.

#### 4.6.9.4 Exhaust Ducts

*From ASHRAE 62.2, Section 7.3, Exhaust Ducts.*

*7.3.1 Multiple Exhaust Fans Using One Duct. Exhaust fans in separate dwelling units shall not share a common exhaust duct. If more than one of the exhaust fans in a single dwelling unit shares a common exhaust duct, each fan shall be equipped with a backdraft damper to prevent the recirculation of exhaust air from one room to another through the exhaust ducting system.*

*7.3.2 Single Exhaust Fan Ducted to Multiple Inlets. Where exhaust inlets are commonly ducted across multiple dwelling units, one or more exhaust fans located downstream of the exhaust inlets shall be designed and intended to run continuously, or a system of one or more backdraft dampers shall be installed to isolate each dwelling unit from the common duct when the fan is not running.*

ASHRAE Standard 62.2 contains restrictions on situations where multiple exhausts are connected through a combined duct system. These restrictions are intended to prevent air from moving between spaces through the exhaust ducts.

The first restriction is that if more than one exhaust fan in a dwelling shares a common duct, then each fan must be equipped with a backdraft damper so that air exhausted from one bathroom or unit is not allowed to go into another space. Exhaust fans in multiple dwelling units may not share a common duct.

The other restriction applies to remote fans serving more than one dwelling unit. Sometimes a single remote fan or HRV/ERV will exhaust air from several dwelling units in a multifamily building. This section requires that either the shared exhaust fan operate continuously or each unit be equipped with a backdraft damper so that air cannot flow from unit to unit when the fan is off.

In multifamily buildings, fire codes may impose additional restrictions.

#### 4.6.9.5 Supply Ducts

*From ASHRAE 62.2, Section 7.4, Supply Ducts.*

*Where supply outlets are commonly ducted across multiple dwelling units, one or more supply fans located upstream of all the supply outlets shall be designed and intended to run continuously, or a system of one or more backdraft dampers shall be installed to isolate each dwelling unit from the*

*common duct when the fan is not running.*

Supply outlets to more than one dwelling unit may be served by a single fan upstream of all the supply outlets if the fan is designed to run continuously or if each supply outlet is equipped with a backdraft damper to prevent cross-contamination when the fan is not running.

---

## 4.7 Alternative Systems

### 4.7.1 Hydronic Heating Systems

*Hydronic heating* is the use of hot water to distribute heat. Hydronic heating is discussed in this compliance manual as an “alternative system” because it is much less common in California than in other parts of the United States.

A hydronic heating system consists of a heat source, which may be a boiler, water heater, or heat pump, and a distribution system. There are three main types of hydronic distribution systems, and they may be used individually or in combination: baseboard convectors or radiators, air handlers, and radiant panel systems. Radiant panel surfaces can include floors, walls, and/or ceilings. Air handlers and radiant panels may be used for heating and cooling. Hot water air handlers may also be equipped with DX coils for cooling. The three distribution options are illustrated in Figure 4-32. Ducting is used only with air handlers.

#### 4.7.1.1 Mandatory Requirements

For hydronic heating systems without ducts, the mandatory measures cover pipe insulation, tank insulation, and boiler efficiency. For fan coils with ducted air distribution, the mandatory air distribution measures also apply. For combined hydronic systems, as described below, mandatory water heating requirements also apply to the water heating portion of the system.

##### A. Pipe and Tank Insulation

*§150.0(j) Insulation for Piping, and Tanks*

*§120.3 Requirements for Pipe Insulation*

The typical residential hydronic heating system operating between 105° and 140° F must have at least 1 inch (25 mm) of insulation on pipes less than 1 inch in diameter and 1.5 inch (38 mm) of insulation on pipes 1 inch or more in diameter. Systems operating between 141° and 200° F must have at least 1.5 inches of insulation on pipes less than 1.5 inches in diameter. For other temperatures and pipe insulation characteristics, see Table 4-5.

There are a few exceptions where insulation is not required:

1. Sections of pipes where they penetrate framing members
2. Pipes that provide the heat exchange surface for radiant heating and/or cooling

3. Piping in the attic that is covered by at least 4 inches (100 mm) of blown insulation on top
4. Piping installed within walls if all the requirements for Insulation Installation Quality are met (see Chapter 3 Building Envelope Requirements).

If the system includes an unfired hot water storage tank, then the tank must be either wrapped with R-12 insulation or insulated internally to at least R-16.

Piping used to deliver chilled water to panels or air handlers should be continuously insulated with closed-cell foam to prevent condensation damage.

**Figure 4-33: Hydronic Heating System Components**

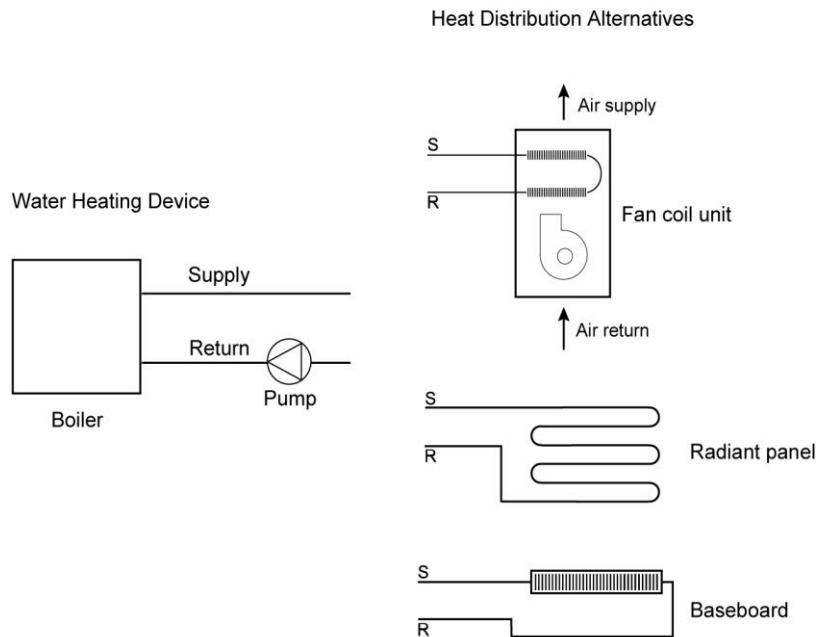

Source: Richard Heath & Associates/Pacific Gas and Electric Company

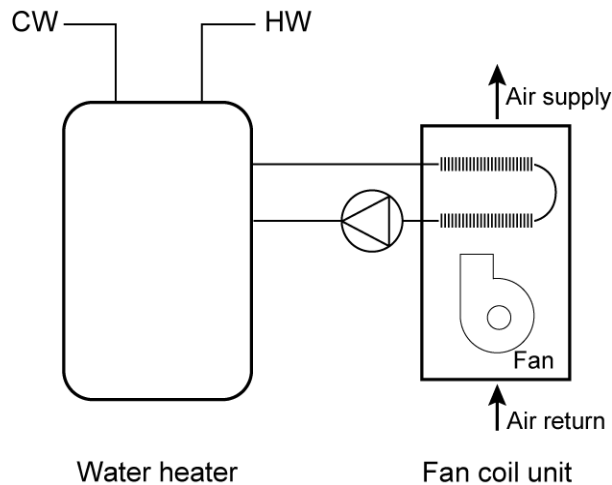
**Figure 4-34: Combined Hydronic System With Water Heater as Heat Source**

Source: Richard Heath & Associates/Pacific Gas and Electric Company

For pipes in hydronic heating systems that operate at pressure greater than 15 psi, the requirements of §120.3 apply. These are the same requirements that apply to nonresidential piping systems.

### B. Equipment Efficiency

Gas or oil boilers used for residential space heating (typically less than 300,000 Btu/hr capacity) must be rated with an AFUE of 80 percent or greater. (See *Appliance Efficiency Regulations, Title 20* for minimum efficiencies of other heating equipment.) A gas or oil water heater may also be used as a dedicated source for space heating. Other hot water sources, including heat pumps or electric resistance water heaters, are not allowed for use in dedicated space-heating systems. Therefore, some water heaters may be used for space heating only if used as part of a combined hydronic system, as described below. In that case, the mandatory water heater requirements apply.

There are no minimum efficiency requirements for heat pumps that produce hot or chilled water, but compliance calculations must use ratings listed in the Energy Commission's Title 20 appliance database under the category "Central Heat Pumps" and Appliance Type "Heat Pump Water Heating Packages."

<https://cacertappliances.energy.ca.gov/Pages/ApplianceSearch.aspx>

Thermostat requirements also apply to hydronic systems, as described in Section 4.5.1.

#### 4.7.1.2 Prescriptive Requirements

There are no specific prescriptive requirements that apply to hydronic systems. However, if the system has a fan coil with ducted air distribution, the relevant prescriptive requirements apply, including duct insulation and duct sealing.



### 4.7.1.3 Performance Compliance Options

Credit for choosing a hydronic heating system is possible using the performance compliance method. The standard design is assumed to have a furnace and ducted air distribution system. Therefore, hydronic systems without ducts can take credit for avoiding duct leakage penalties. In addition, minimizing the amount of pipe outside conditioned space will provide some savings. Hydronic heating and cooling compliance calculations are described in the *Residential ACM Manual*.

If the proposed hydronic system includes ducted air distribution, then the associated compliance options described earlier in this chapter may apply, such as improved airflow (if there is air conditioning) and supply duct location.

A “combined hydronic” system is another compliance option that is possible when using the performance method. *Combined hydronic heating* refers to the use of a single water heating device as the heat source for space and domestic hot water heating.

Combined hydronic systems may use either a boiler (as in the figure below) or a water heater as a heat source. The boiler heats domestic water by circulating hot water through a heat exchanger in an indirect-fired water heater. The water heater provides domestic hot water as usual.

**Figure 4-35: Combined Hydronic System With Boiler and Indirect Fired Water Heater**

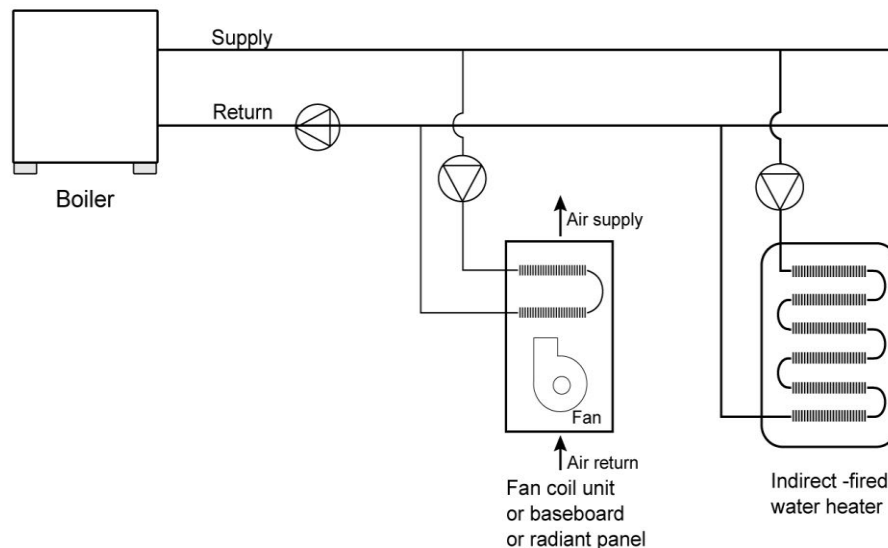

Source: Richard Heath & Associates/Pacific Gas and Electric Company

Space heating is accomplished by circulating water from the boiler or water heater through the space heating delivery system. Sometimes a heat exchanger is used to isolate potable water from the water circulated through the delivery system. Some water heaters have built-in heat exchangers for this purpose.

For compliance calculations, the water-heating function of a combined hydronic system is analyzed for water-heating performance as if the space-heating function were separate. For the space-heating function, an “effective” AFUE or HSPF rating

is calculated. These calculations are performed automatically by the compliance software.

#### 4.7.2 Radiant Floor System

**§110.8(g) and Table 118.0-A**

Radiant floor systems, using either hydronic tubing or electric cable, must meet mandatory insulation measures. (See below.) Radiant floors may take one of several forms. Tubing or electric elements for radiant floor systems may be:

1. Embedded in a concrete floor slab.
2. Installed over the top of a wood subfloor and covered with a concrete topping.
3. Installed over the top of a wood subfloor in between wood furring strips.
4. Installed on the underside surface of a wood subfloor

In the latter two types of installations, aluminum fins are typically installed to spread the heat evenly over the floor surface and to reduce the temperature of the water as required. All hydronic systems use one or more pumps to circulate hot water. Pumps are controlled directly or indirectly by thermostats or by special outdoor reset controls. When concrete slabs are heated by radiant tubing or cables, one of the insulation methods listed below must be complied with to prevent excessive heat loss from the slab edge.

**Table 4-16: Slab Insulation Requirements for Heated Slabs**

Location of Insulation	Orientation of Insulation	Installation Criteria	Climate Zone	Insulation R-Value
Outside edge of heated slab, either inside or outside the foundation wall	Vertical	From the level of the top of the slab, down 16 inches or to the frost line, whichever is greater. Insulation may stop at the top of the footing where this is less than the required depth.  For below-grade slabs, vertical insulation shall be extended from the top of the foundation wall to the bottom of the foundation (or the top of the footing) or frost line, whichever is greater.	1-15	5
Outside edge of heated slab, either inside or outside the foundation wall	Vertical	From the level of the top of the slab, down 16 inches or to the frost line, whichever is greater. Insulation may stop at the top of the footing where this is less than the required depth.  For below-grade slabs, vertical insulation shall be extended from the top of the foundation wall to	16	10

Location of Insulation	Orientation of Insulation	Installation Criteria	Climate Zone	Insulation R-Value
		the bottom of the foundation (or the top of the footing) or frost line, whichever is greater.		
Outside edge of heated slab, either inside or outside the foundation wall	Vertical	<p>From the level of the top of the slab, down 16 inches or to the frost line, whichever is greater. Insulation may stop at the top of the footing where this is less than the required depth.</p> <p>For below-grade slabs, vertical insulation shall be extended from the top of the foundation wall to the bottom of the foundation (or the top of the footing) or frost line, whichever is greater.</p>	1-15	5
Between heated slab and outside foundation wall	Vertical and Horizontal	<p>Vertical insulation from the top of the slab at the inside edge of the outside wall down to the top of the horizontal insulation.</p> <p>Horizontal insulation from the outside edge of the vertical insulation extending 4 feet toward the center of the slab in a direction normal to the outside of the building in the plan view.</p>	16	10 vertical and 7 horizontal

Source: 2019 Energy Standards Table 110.8-A

The required insulation value for each of these insulating methods is shown in Table 4-16.

Slab edge insulation applied to basement or retaining walls (with heated slab below grade) must be installed so that insulation starts at or above ground level and extends down to the bottom of the foundation or to the frost line, whichever is greater.

When using the performance compliance method with slab-on-grade construction, the standard design includes slab edge insulation as described above using the F-factors in Reference Joint Appendix JA4, Table 4.4.8.

When tubing or heating cables are set into a lightweight concrete topping slab laid over a raised floor, the edges of the radiant panel must not extend beyond the inside surface of insulated walls, and underside insulation must meet the mandatory minimum R-value for wood floor assemblies.

**Figure 4-36: Heated Slab-On-Grade Floor Insulation Options**

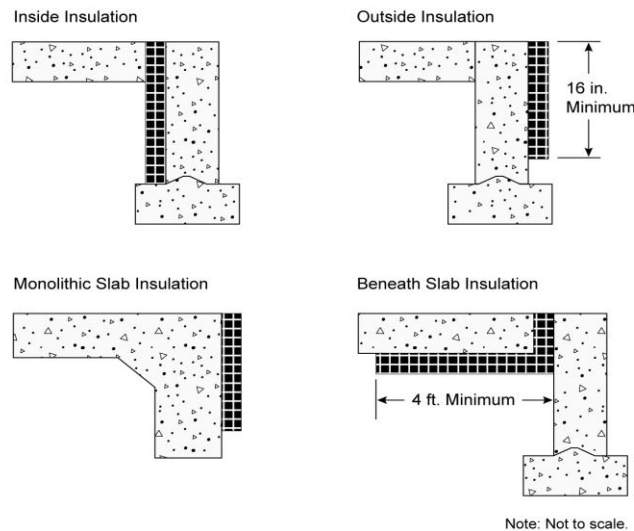

Source: California Energy Commission

Local conditions (such as a high water table) may require special insulation treatment to achieve satisfactory system performance and efficiency. To determine the need for additional insulation, follow the recommendations of the manufacturer of the hydronic tubing or heating element being installed. Where there is any danger of termite infestation, install termite barriers to prevent hidden access for insects from

the ground to the building framing. Termite barrier flashing should be embedded into the concrete.

In addition to the insulation R-value requirements, §110.8(g)1 also sets mandatory measures related to moisture absorption properties of the insulation and protection of the insulation from physical damage or pest intrusion.

---

**Example 4-36****Question:**

My client wants a dedicated hydronic-heating system (space heating only), but a few things are unclear: (1) What piping insulation is required? (2) Can I use any compliance approach? (3) Do I have to insulate the slab with slab edge insulation? (4) What special documentation must be submitted for this system type?

**Answer:**

(1) The supply lines not installed within a concrete radiant floor must be insulated in accordance with §150.0(j)2— Systems operating between 105° and 140° F must have at least 1 inch of insulation on pipes less than 1 inch in diameter, and 1.5 inches of insulation on pipes between 1 inch and less than 1.5 inches in diameter. Systems operating between 141° and 200° F must have at least 1.5 inches of insulation on pipes less than 1.5 inches in diameter.

(2) You can use any compliance approach, but the boiler must meet the mandatory efficiency 80 percent AFUE.

(3) The slab edge insulation shown in Table 4-16 is required only when the distribution system is a slab-on-grade radiant floor system (pipes in the slab). When this is the case, the insulation values shown are mandatory measures (no modeling or credit).

(4) No special documentation is required.

---

**Example 4-37****Question:**

What are the slab edge insulation requirements for a hydronic-heating system with the hot water pipes in the slab?

**Answer:**

The requirements for slab edge insulation can be found in §110.8 and §150.0(I).

Material and installation specifications are as follows:

1. Insulation values as shown in Table 4-16
2. Protected from physical damage and ultraviolet light deterioration
3. Water absorption rate no greater than 0.3 percent (ASTM-C272)
4. Water vapor permeance no greater than 2.0 per inch (ASTM-E96-14).

**4.7.3 Evaporative Cooling**

Evaporative coolers cool a building by passing outdoor air through a wetted evaporative medium (direct evaporative cooler), by indirect cooling through a nonporous heat exchanger separating evaporatively cooled secondary air from outdoor air, or by a combination indirect-direct system that combines an indirect heat exchanger with a downstream direct evaporative process. Although direct coolers are most common, the more advanced indirect and indirect-direct systems offer generally lower supply air temperatures with less moisture introduced to the indoor space. For the Energy Standards, performance credit is allowed only for indirect and indirect-direct evaporative cooling systems. All coolers receiving credits within the *ACM Manual* must be listed in the Energy Commission's Title 20 Evaporative Cooler appliance database

(<https://cacertappliances.energy.ca.gov/Pages/ApplianceSearch.aspx>).

Evaporative coolers may be used with any compliance approach. In the prescriptive compliance approach, all evaporative coolers are treated as a minimum efficiency 13.0 SEER air conditioner.

In the performance approach, the compliance software uses an hourly model based on unit effectiveness, supply airflow, and power to determine the magnitude of the credit based on climate conditions and unit sizing relative to the loads. Typical cooling budget credits are 20-30 percent, depending upon these factors.

The evaporative cooling system must meet the following requirements to receive credit based on the hourly performance method described above. Direct coolers, as well as indirect and indirect-direct coolers not meeting these criteria, shall be modeled as a minimum efficiency (13.0 SEER) central air conditioner.

1. The equipment manufacturer shall certify to the Energy Commission that water use does not exceed 7.5 gallons per ton hour based on the Title 20 Appliance Efficiency Regulations testing criteria.

2. Equipment shall be permanently installed (no window or portable units).
3. Installation shall provide for automatic relief of supply air from the house with maximum air velocity through the relief dampers not exceeding 800 feet per minute (at the Title 20 rated airflow). Pressure relief dampers and ductwork shall be distributed to provide adequate airflow through all habitable rooms. For installations with an attic, ceiling dampers shall be installed to relieve air into the attic and then outside through attic vents. For installations without an attic, sidewall relief dampers are acceptable.
4. To minimize water consumption, bleed systems are not allowed.
5. A water quality management system (either “pump down” or conductivity sensor) is required. “Pump down” systems can either be integral to the evaporative cooler or they can be accessories that operate on a timed interval. The time interval between pumps shall be set to a minimum of 6 hours of cooler operation. Longer intervals are encouraged if local water quality allows. Automatic systems that use conductivity sensors provide the best water efficiency compared to a timed pump down system. These sensors monitor the water quality and don’t unnecessarily drain the water based on elapsed time.
6. Automatic thermostats are required. Manual on/off controls are not allowed.
7. If the evaporative cooler duct system is shared with a heating and/or cooling system, the installed duct system shall employ backdraft dampers at the evaporative cooler supply.
8. The installing contractor must provide a winter closure device that substantially blocks outdoor air from entering the indoor space.
9. The size of the water inlet connection at the evaporative cooler shall not exceed 3/8 inch.
10. Unless prohibited by local code, the sump overflow line shall not be directly connected to a drain and shall terminate in a location that is normally visible to the building occupants.

**Example 4-38****Question:**

How are applications with vapor compression cooling systems and evaporative cooling systems handled?

**Answer:**

In situations where evaporative cooling system(s) and vapor compression system(s) are installed in a house, the size of the evaporative cooler will dictate the magnitude of the credit. The performance approach will ensure that an evaporative cooler sized to meet most of the cooling loads will generate a higher credit than one sized to meet a fraction of the design cooling load.

**Example 4-40****Question:**

How do you model multiple evaporative coolers on one house?

**Answer:**

In situations with multiple evaporative coolers, effectiveness inputs should be averaged, and airflow and power inputs should be totaled. Performance characteristics of each piece of equipment should be listed on the compliance forms.

**4.7.4 Ground-Source Heat Pumps**

**Table 4-17 – Standards for Ground Water-Source and Ground-Source Heat Pumps Manufactured on or After October 29, 2003**

Appliance	Rating Condition	Minimum Standard
Ground water-source heat pumps (cooling)	59° F entering water temperature	16.2 EER
Ground water-source heat pumps (heating)	50° F entering water temperature	3.6 COP
Ground-source heat pumps (cooling)	77° F entering brine temperature	13.4 EER
Ground-source heat pumps (heating)	32° F entering brine temperature	3.1 COP

Section 1605.3 Table C-7 of the *2015 California Appliance Efficiency Regulations*

A geothermal or ground-source heat pump uses the earth as a source of energy for heating and as a heat sink for energy when cooling. Some systems pump water from an aquifer in the ground and return the water to the ground after exchanging heat with the water. A few systems use refrigerant directly in a loop of piping buried in the ground. Those heat pumps that either use a water loop or pump water from an aquifer have efficiency test methods that are accepted by the Energy Commission.

The mandatory minimum efficiencies for ground water-source heat pumps shown in Table 4-17 are certified to the Energy Commission by the manufacturer and are expressed in terms of coefficient of performance (COP) for heating and EER for cooling.

Verify that the system will meet local code conditions before choosing this type of system to meet the Energy Standards.

**4.7.5 Solar Space Heating**

Solar space-heating systems are not recognized within either the prescriptive packages or the performance compliance method.

**4.7.6 Wood Space Heating**

The Energy Commission's exceptional method for wood heaters with any type of backup heating is available in areas where natural gas is not available. If the required eligibility criteria are met, a building with one or more wood heaters may be shown to comply with the Energy Standards using either the prescriptive or performance approaches as described below.



#### 4.7.6.1 Prescriptive Approach

The building envelope conservation measures of the component package must be installed. The overall heating system efficiency (wood stove plus backup system) must comply with the prescriptive requirements.

#### 4.7.6.2 Performance Approach

A computer compliance method may be used by modeling wood heat, which simulates an 80 percent AFUE central furnace with ducts that meet prescriptive requirements.

#### 4.7.6.3 Wood Heater Qualification Criteria

The Energy Standards establish exceptional method guidelines for the use of wood heaters. If all the criteria for the wood heat exceptional method are not met, a backup heating system must be included in the compliance calculations as the primary heat source.

The building department having jurisdiction must determine that natural gas is not available.

*Note:* Liquefied petroleum gas, or propane, is not considered natural gas.

The following eligibility criteria apply:

1. The local or regional air quality authority must determine that its authorization of this exceptional method is consistent with state and regional ambient air quality requirements according to Sections 39000 to 42708 of the California Health and Safety Code.
2. The wood heater must be installed in a manner that meets the requirements of all applicable health and safety codes, including, but not limited to, applicable requirements for maintaining indoor air quality.
3. The wood heater must meet the EPA definition of a wood heater as defined in Title 40, Part 60, Subpart AAA of the Code of Federal Regulations (40CFR60 Subpart AAA) (See below.)
4. The performance of the wood heater must be certified by a nationally recognized agency and approved by the building department having jurisdiction to meet the performance standards of the EPA.
5. The rated output of the wood heater must be at least 60 percent of the design heating load, using calculation methods and design conditions as specified in §150(h).
6. At the discretion of the local enforcement agency, a backup heating system may be required and designed to provide all or part of the design heating load, using calculation methods and design conditions as specified in §150(h).
7. The wood heater must be located such that transfer of heat from the wood heater is effectively distributed throughout the entire residential dwelling unit, or

it must be used in conjunction with a mechanical means of providing heat distribution throughout the dwelling.

8. Habitable rooms separated from the wood heater by one free opening of less than 15 ft<sup>2</sup> or two or more doors must be provided with a positive heat distribution system, such as a thermostatically controlled fan system. Habitable rooms do not include closets or bathrooms.
9. Wood heaters on a lower level are considered to heat rooms on the next level up, provided they are not separated by two or more doors.
10. The wood heater must be installed according to manufacturer and local enforcement agency specifications and must include instructions for homeowners that describe safe operation.
11. The local enforcement agency may require documentation that demonstrates that a particular wood heater meets all these requirements.

Federal regulation 40CFR60 Subpart AAA includes minimum criteria for wood heaters established by the U.S. EPA. These criteria define a wood heater as an enclosed, wood-burning appliance capable of and intended for space heating or domestic water heating that meets all the following criteria:

1. An air-to-fuel ratio averaging less than 35 to 1
2. A firebox volume less than 20 ft<sup>3</sup>.
3. A minimum burn rate less than 5 kilogram/hour (11.0 lbs/hr)
4. A maximum weight of less than 800 kilograms (1,760 lbs)
5. The federal rules explicitly exclude furnaces, boilers, cook stoves, and open masonry fireplaces constructed on site, but include wood-heater inserts.

---

#### Example 4-41

**Question:**

Are pellet stoves treated the same as wood stoves for compliance with the Energy Standards?

**Answer:**

Yes.

#### Example 4-42

**Question:** If a wood stove is installed in a wall, does it have to meet the fireplace requirements of §150(e)?

**Answer:**

No. A wood stove that meets EPA certification requirements does not have to meet any requirements applicable to fireplaces.

---

#### 4.7.7 Gas Appliances

##### §110.5 Pilot Lights

Pilot lights are prohibited in fan-type central furnaces, pool heaters, spa heaters, and natural gas indoor and outdoor fireplaces.

Household cooking appliances are also prohibited from having a pilot light unless there is no electrical supply voltage connection and each pilot consumes less than 150 Btu/hr.

For requirements related to installation of fireplaces, decorative gas appliances, and gas logs, see Chapter 3 of this manual.

#### 4.7.8 Evaporatively Cooled Condensers

*Evaporatively cooled condenser air conditioners* are a type of air-conditioning system that can provide significant space-cooling savings, especially in hot, dry climates. The equipment minimal efficiencies are determined according to federal test procedures. The efficiencies of these air conditioners are reported in terms of energy efficiency rating (EER).

If credit is taken for a high EER, field verification by a HERS Rater is required. Other HERS-verified measures are also required, including duct sealing, airflow, fan efficacy, and refrigerant charge or fault indicator display.

Besides the HERS verification, there are additional special requirements for evaporatively cooled condensing air conditioners. These include that the manufacturer provide certification that water use is limited to no more than 0.15 gallon per minute per ton of capacity and that the supply line be no larger than ¼-inch in diameter. For a listing of all the requirements for evaporatively cooled condensing air conditioners, see the CF2R compliance form.

#### 4.7.9 Nonducted Systems

Several manufacturers offer equipment that does not use air distribution ducts to heat or cool spaces. These systems use either refrigerant or water that is heated and/or cooled to condition the space. These systems may provide advanced controls and multispeed compressors for optimizing performance through a wide range of conditioning loads without losing efficiency.

These systems are required to be modeled as minimally efficient systems because a compliance option that specifies appropriate modeling rules and installation criteria has not been developed or approved. All applicable HERS verifications are required to be conducted for these systems, if possible.

#### 4.7.10 Ventilation Cooling

*Ventilation cooling* is differentiated from the mechanical ventilation provided to maintain adequate indoor air quality, in that the primary focus is to bring in higher

volumes of cool outdoor air (if available) to cool the dwelling unit to reduce the use of conventional vapor compression air conditioning. Ventilation cooling systems generally operate during summer evenings and nights when cooler outdoor air is available. The cooler outdoor air ventilation reduces indoor air temperatures during the evening and nighttime hours, and in the process cools the building interior thermal mass, which may offset or eliminate the next-day cooling loads of the dwelling. Ventilation cooling systems may cool the dwelling to temperatures that are below the normal air conditioner set point, which may improve the effectiveness of the next-day cooling load offset. The effectiveness of ventilation cooling depends upon the climate conditions, thermal envelope, and how much indoor temperature variation the occupant will tolerate.

Figure 4-37 compares cooling energy use over a day for two identical houses, one with and one without ventilation cooling, and illustrates how ventilation cooling can offset most of the air-conditioning energy by use of a relatively small amount of off-peak ventilation fan operation.

**Figure 4-37: Diurnal Temperature Variation and Ventilation Cooling**

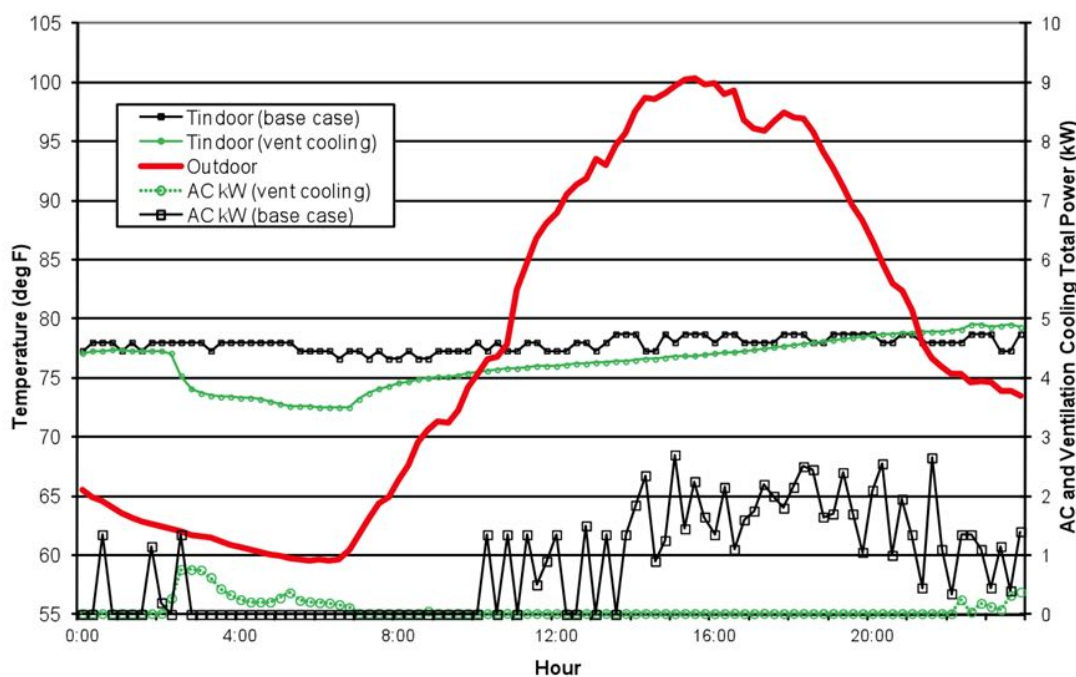

Source: California Energy Commission

#### 4.7.10.1 Whole-House Fans

The simplest form of ventilation cooling is a whole-house fan (WHF), which draws cooler outdoor air through open windows, exhausts the warmer air into the attic, and then expels the air outside through attic vents.

Traditional whole-house fans have a simple barometric damper (Figure 4-38) and either a belt-driven or direct-drive motor driving a prop fan. Figure 4-39 shows the damper open with the fan immediately above.

Figure 4-40 shows a similar product that moves less air but provides an insulated damper with a better leakage seal between the attic and conditioned space. These units are generally designed to fit between standard rafter spacing, simplifying retrofit installations.

Finally, Figure 4-41 shows a remote whole-house fan design that removes the fan farther from indoor space, reducing noise during operation.

WHFs cool a dwelling space most effectively when all windows throughout the house are opened only enough to produce a fairly uniform airflow into all rooms throughout the dwelling while not restricting the WHF total airflow. This results in the greatest interaction of the cool air with the interior mass throughout the dwelling, providing the greatest amount of stored cooling. Running the fan all night long increases the effectiveness of the next-day cooling offset by more fully “charging” the thermal mass. Noise can be reduced through either use of a variable-speed control or installation of a multispeed fan, allowing low-speed nighttime operation.

Security concerns may arise if windows are left open at night, but most window products can be secured if they are only partially open, thus providing the minimum open area for air to enter the room but preventing unauthorized entry from outside the dwelling.

Homeowners who have sensitivities to particulate matter in the outdoor air should consider that dust and allergens present in the outdoor air will easily enter the dwelling through the open windows during operation of a WHF.

The WHFs used to comply with the Energy Standards must be listed in the Energy Commission’s Appliance Database which can be accessed at <https://cacertappliances.energy.ca.gov/Pages/ApplianceSearch.aspx>.

**Figure 4-38: Whole-House Fan With Barometric Damper**



Source: California Energy Commission

**Figure 4-39: Open Barometric Damper With Fan Above**



Source: California Energy Commission

**Figure 4-40: Insulated Whole-House Fan With Damper Actuation**



Source: California Energy Commission

**Figure 4-41: Ducted Remote Whole-House Fan**



Source: California Energy Commission

#### 4.7.10.2 Central Fan Ventilation Cooling Systems

Another type of ventilation cooling system, the central fan ventilation cooling system (CFVCS) uses an automatically controlled outside air damper and the HVAC system fan or other fan to draw outside air through a large outdoor air vent and distributes the cool outdoor air through the HVAC system ductwork. Warm indoor air is then expelled into the attic through the same damper.

Primary advantages of this system include filtration of outside air, elimination of the need to open windows (improved security), and automatic sensing of the moment when the outdoor air temperature falls below the indoor temperature. A disadvantage of central fan systems is that they typically move less air and consume more energy per CFM as compared to a whole-house fan because of the more restrictive duct systems.

Figure 4-42 shows the airflow path through a CFVCS when the system is not operating to provide ventilation cooling (return air mode). In this mode, the system performs the same as a conventional central space-conditioning system, drawing the return air from the conditioned space, through the heating/cooling coils, then back to the conditioned space.

**Figure 4-42: Central Fan Ventilation Cooling System (Return Air Mode)**

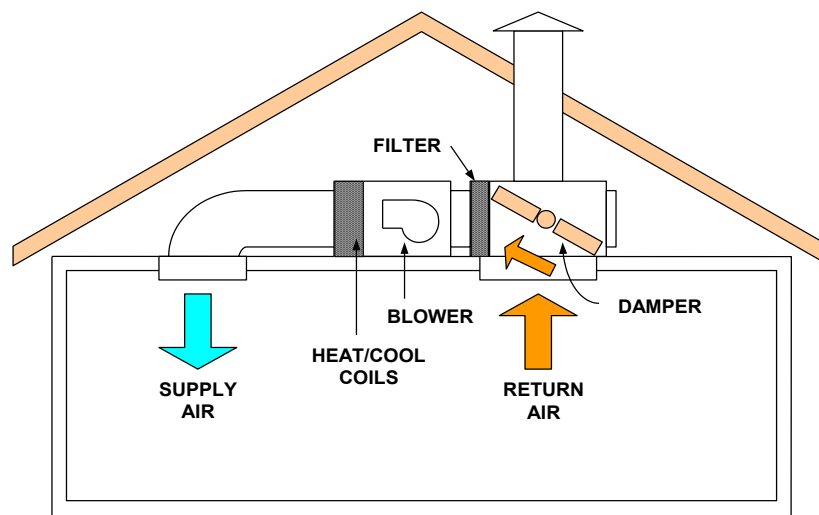

Source: California Energy Commission

Figure 4-43 shows the airflow paths when the system is operating to provide ventilation cooling (outdoor air mode). In this mode, the damper changes position and draws outdoor air through the outdoor air intake vent, through the air handler, and then to the conditioned space. During outdoor air mode, the cooling/heating coils are not operated, and the damper allows indoor air to pass into the attic, then back to outdoors through the attic vents.

Figure 4-43: Central Fan Ventilation Cooling System (Outdoor Air Mode)

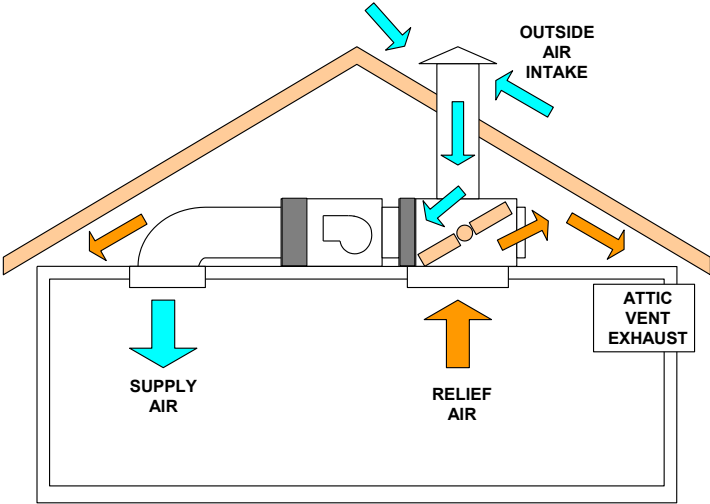

Source: California Energy Commission

Figure 4-44: Sample Rooftop Air Intake



Source: California Energy Commission



**Figure 4-45: Sample Gable End Air Intake (Lower Set of Vents)**

Source: California Energy Commission

CFVCSs may use a variable-speed motor with a fan-speed control that responds to outdoor temperature conditions and indoor comfort settings, which may improve energy savings compared to fixed-speed CFVCSs.

#### 4.7.10.3 Prescriptive Requirements

Component packages specify a WHF as a prescriptive requirement for single-family newly constructed buildings in Climate Zones 8 through 14. The WHF, or CFVCS, must meet the eligibility criteria specified below to meet the prescriptive requirement.

Additions of 1,000 ft<sup>2</sup> or less are exempt from the whole-house fan prescriptive requirements.

##### 4.7.10.3.1 Eligibility Criteria for Whole-House Fans

###### §150.1(c)12

1. Where atmospherically vented combustion appliances or solid-fuel burning appliances are located inside the pressure boundary, the operation of the whole-house fan must be considered in determining the adequacy of providing combustion air and prevention of back-drafting, which may cause toxic combustion products to enter conditioned space of the dwelling.
2. WHFs used to comply with the Energy Standards must be listed in the Energy Commission Appliance Database.
3. To meet the prescriptive requirement, the installed WHF(s) must have a listed airflow of at least 1.5 CFM/ft<sup>2</sup> of conditioned floor area. The house must have a minimum attic net free vent area to outdoors of one square foot

per 750 CFM of installed whole-house fan(s) rated airflow. See Table 4-18 and Table 4-19 for net free ventilation area requirements based on the square footage of the house.

4. Homeowners who have WHFs installed must be provided with a one-page “How to operate your whole house fan” informational sheet.

#### **A. Eligibility Criteria for Central Fan Ventilation Cooling Systems**

CFVCS may be approved for use for compliance credits as “fixed-speed” systems or as “variable speed” systems. The Energy Commission must review submittals from manufacturer applicants and determine whether the system meets the qualifying criteria:

When applying for approval for either fixed speed or variable speed systems, the manufacturer must provide documentation to demonstrate the system meets the criteria listed in paragraphs 1, 2, and 3 below

1. CFVCS must meet the applicable duct leakage requirements with the system operating in return air mode (Figure 4-42).
2. CFVCS must be HERS verified for airflow (CFM) and fan efficacy (w/CFM), demonstrating an efficacy of no more than 0.45 watts/CFM for furnaces, 0.58 W/CFM for heat pumps, and 0.62W/CFM for small duct, high velocity systems.
3. In addition to sensing temperature at the thermostat, the CFVCS must have an outdoor temperature sensor to initiate and terminate ventilation cooling operation and a means to detect damper failure.

When applying for approval as a variable speed system, the manufacturer must also provide the documentation described in paragraphs 4, 5, and 6 below.

4. The installed fan motor is a variable-speed motor.
5. The motor is controlled in ventilation cooling mode to vary in a continuous range between full air flow (100 percent) and a minimum airflow of no more than 25 percent of full airflow.
6. The manufacturer must provide written documentation that describes how its control strategy is implemented, how the ventilation cooling fan speed is controlled, and how ventilation cooling rates are determined. The ventilation cooling rate calculation must occur within a 24-hour interval or less to ensure that the system responds in a timely manner to changes in weather patterns.

Table 4-18 shows example conversions for the calculated net free vent area (NFVA) for a range of whole-house fan airflow levels. Instead of using the table, one can calculate the NFVA by dividing the listed CFM by 750.

**Table 4-18: Sample NFVA Calculation**

CEC Listed Airflow (CFM)	Minimum Attic NFVA (ft <sup>2</sup> )
2000	2.7
3000	4
4000	5.3
5000	6.7
6000	8
7000	9.3

Source: California Energy Commission

Since attic vents present some level of airflow restriction, use the appropriate screen and louver reduction factor from Table 4–19.

**Table 4-19: Attic Vent Airflow Reduction Factors**

Vent Type	Reduction Factor
¼" screen (hardware cloth)	0.90
¼" screen with metal louvers	0.75
¼" screen with wood louvers	0.25
Insect screen (mesh under ¼")	0.50
Insect screen with metal louvers	0.50
¼" screen with wood louvers	0.25

Source: California Energy Commission

**Example 4-43**

Required vent area = Minimum Attic NFVA (Table 4-18) ÷ Reduction Factor

A 3,000 CFM fan is selected from the Energy Commission Appliance Database. The builder plans to use vents with ¼" screen with metal louvers.

**Answer**

The minimum required vent area is =  $4.0 \div 0.90 = 4.4 \text{ ft}^2$

**Example 4-44 – Ventilation Cooling****Question:**

I am building a 2,350 ft<sup>2</sup> house in Climate Zone 8. Do I need to install a whole-house fan or central fan ventilation system?

**Answer:**

Yes, if you are complying prescriptively.

No, if you are complying using the performance method and no whole-house fan was modeled.

Whole-house fans are a prescriptive requirement in Climate Zones 8-14, meaning that they are not mandatory, although they define the prescriptive compliance level. If you decide to install a whole-house fan to meet the prescriptive requirement, you should select a fan from the Energy Commission Appliance Database. The prescriptive requirement specifies a minimum airflow of 1.5 CFM/ft<sup>2</sup> (3,525 CFM for the proposed house) and 1 ft<sup>2</sup> of attic net free ventilation area per 750 CFM of airflow (4.7 ft<sup>2</sup> for a 3,525 CFM fan).

#### Example 4-45

**Question:**

Why do I need to provide attic ventilation area for a whole-house fan?

**Answer:**

Whole-house fans move a lot of air from inside the dwelling unit, all of which is exhausted to the attic. Without sufficient attic relief to the outdoors, the fan will move less air.

#### Example 4-46

**Question:**

What are the advantages and disadvantages of whole-house fans relative to central fan ventilation cooling systems?

**Answer:**

Whole-house fans are relatively inexpensive; both in first cost and operating cost and are highly effective if used properly in the right climate. They move much more air than central fan systems, which must deliver air through the duct system. Whole-house fans may be noisy, require user operation to open windows, turn on and off, bring in dust and allergens from outside, and potentially reduce home security if windows are left open throughout the night. Central fan systems are more expensive and generally move less air, but provide totally automated operation, independent of whether the occupant is home. Windows can remain shut, and all outdoor air is filtered. Some central fan systems may also be configured to provide ventilation that complies with the whole-dwelling indoor air quality requirements in Section 150.0(o). Review product literature to determine if available products meet the Energy Commission's fresh air ventilation requirements.

#### Example 4-47

**Question:**

A two-story home with 2,500 sf of conditioned space and an attic is located in Climate Zone 10. Is a whole-house fan required? Does this affect the number of vents in the attic?

**Answer:**

Yes, if complying prescriptively. Section 150.1(c)12 requires whole-house fans (WHF) in single-family houses that are in Climate Zones 8-14. These are climate zones that have summer cooling needs but where the home can be efficiently cooled on cool summer evenings by the use of a whole-house fan.

Section 150.1(c)12 also requires that these fans be sized so they provide at least 1.5 cubic feet per minute (CFM) of flow for each square foot of conditioned space in the house. The fans used must be listed in the Energy Commission's Appliance Database (<http://appliances.energy.ca.gov/QuickSearch.aspx>) and the rated CFM listed on the CF2R-MCH-02 form. In addition, the attic must have at least 1 sf of attic vent free area for each 750 CFM of whole-house fan-rated flow.

Thus, for this house with 2,500 sf of conditioned floor area, the minimum total flow rate of whole-house fans installed in the house must be at least:

Min WHF flow rate = Conditioned Floor Area x 1.5 CFM/sf = 2,500 sf x 1.5 CFM/sf = 3,750 CFM.

In this case, the builder has selected two 2,000 CFM whole-house fans. The minimum amount of vent net-free area in the attic is calculated as follows:

Net Free Area = Total WHF CFM / (750 CFM/sf NFA) = (2,000 + 2,000) / 750 = 5.3 sf

---

## 4.8 Refrigerant Charge

### 4.8.1 Refrigerant Charge Verification

This section summarizes the procedures for verifying refrigerant charge for air-conditioning systems as described in Section RA3.2 of the Reference Residential Appendix.

#### 4.8.1.1 Overview

A split-system air conditioner undergoes the final assembly at installation. The installation must be verified to ensure proper performance. Important factors that affect performance include the amount of refrigerant in the system (the charge) and the proper functioning of the metering device. Air conditioner energy efficiency suffers if the refrigerant charge is either too low or too high and if the metering device (TXV or EXV) is not functioning properly. In addition to a loss of efficiency and capacity, errors in these areas can lead to premature compressor failure.

To help avoid these problems, the prescriptive standards require that systems be correctly installed. The prescriptive standards also require that they be field-verified in Climate Zones 2 and 8 through 15. Refrigerant charge verification is also required in any climate zone when chosen as a compliance feature using the performance approach.

The requirement to verify the refrigerant charge after installation does not apply to new packaged systems, where the installer certifies the package system came factory-charged and did not alter the system in any way that would affect the

refrigerant level; however, airflow and other requirements must still be verified. The prescriptive standards regarding verification of refrigerant charge do apply to altered package systems in Climate Zones 2 and 8 through 15.

Verification of proper refrigerant charge must occur after the HVAC contractor has installed and charged the system in accordance with the manufacturer's specifications. The procedure requires properly calibrated digital refrigerant gauges, thermocouples, and digital thermometers. When multiple systems in the same home require testing, test each system.

In a typical home cooling system, there are two important performance criteria that are relatively easy to verify that there is neither too much nor too little refrigerant in the system. In systems with a fixed-orifice device in the evaporator coil, the number to check is called the *superheat*. In a system with a variable-metering device, the number to check is called the *subcooling*.

*Superheat* refers to the number of degrees the refrigerant is raised after it evaporates into a gas. This occurs inside the evaporator coil (or *indoor coil*). The correct superheat for a system will vary depending on certain operating conditions. The target superheat for a system must be obtained from a table provided in the RA3.2 protocols or the manufacturer's superheat table. There is an allowed range of several degrees between the measured superheat and the target superheat for a system to pass.

Subcooling refers to the number of degrees the refrigerant is lowered after it condenses into a liquid. This occurs inside the condenser coil (or *outdoor coil*). The manufacturer specifies the correct subcooling for a system. It may vary depending on operating conditions. Like superheat, there is an allowed range of several degrees between the measured subcooling and the target subcooling for a system to pass.

The temperature at which a refrigerant condenses or evaporates is called the *saturation temperature*. Above the saturation temperature, a refrigerant is always a gas. Below the saturation temperature, a refrigerant is always a liquid.

Saturation is when a refrigerant exists as both a liquid and a gas. It always occurs at the same temperature, depending on what the pressure of the refrigerant happens to be. At higher pressures, the saturation temperature goes up and vice versa. This convenient property is what makes refrigeration work.

The saturation temperature can be determined by simply measuring the pressure of a refrigerant and referring to a table, known as a *pressure-temperature (PT) table*, for that specific refrigerant. Saturation temperatures are well-documented for all common refrigerants.

Because variable refrigerant metering devices are prone to failure and even more so to improper installation, it is important that the operation of these devices be checked. A metering device maintains a relatively constant superheat over a wide range of operating conditions; therefore, checking the superheat, in addition to the other tests performed, will indicate if the metering device is operating correctly.

Unfortunately, checking superheat and subcooling can be done only under certain indoor and outdoor conditions. This verification procedure, called the Standard Charge Verification Method, is very weather-dependent.

There is another way to verify proper refrigerant charge that is not weather-dependent, and that is by weighing the refrigerant. Called the Weigh-in Charge Verification Method, this approach can be performed only by the installer. It can be verified by the HERS Rater either by simultaneous observation or by using the standard method when conditions permit.

#### **4.8.1.2 Minimum System Airflow Verification for Refrigerant Charge Verification**

To have a valid charge test, the system airflow must be verified to be at least 300 CFM/ton for altered systems and 350 CFM/ton for new systems. The procedures for measuring total system airflow are found in RA3.3. They include plenum pressure matching using a fan flow meter, a flow grid, a powered flow hood, and the traditional (nonpowered) flow hood. The airflow verification procedures for refrigerant charge verification no longer include the temperature split method.

If an altered system does not meet the minimum airflow requirements, remedial steps are required to increase system airflow. More airflow is generally better for systems with air conditioning. Not only does this allow proper refrigerant charge to be verified, but it improves the overall performance of the system. When able to be performed on a system, regardless of the refrigerant charge verification procedure, minimum system airflow must always be verified.

In some alterations, improving airflow may be cost-prohibitive, and there is a process for documenting this (RA3.3.3.1.5). When this option is used, verification by sample groups is not allowed. Minimum airflow is critical to proper air-conditioner operation. Reducing airflow reduces cooling capacity and efficiency. Many systems in California have oversized equipment and undersized ducts. In newly installed duct systems, the minimum airflow requirement is higher because the opportunity exists to design and install a better system. In altered systems, the installer may be required to modify the ducts system to meet the minimum airflow. The minimums of 300 and 350 CFM/ton are lower than the desired airflow for most systems, which is usually 400 CFM/ton and higher.

#### **4.8.1.3 Standard Charge Verification Procedure (RA3.2.2)**

The first step is to turn on the air-conditioning system and let it run for at least 15 minutes to stabilize temperatures and pressures. While the system is stabilizing, the HERS Rater or the installer may attach the instruments needed to take the measurements.

**Figure 4-45: Measurements for Refrigerant Charge and Airflow Tests**

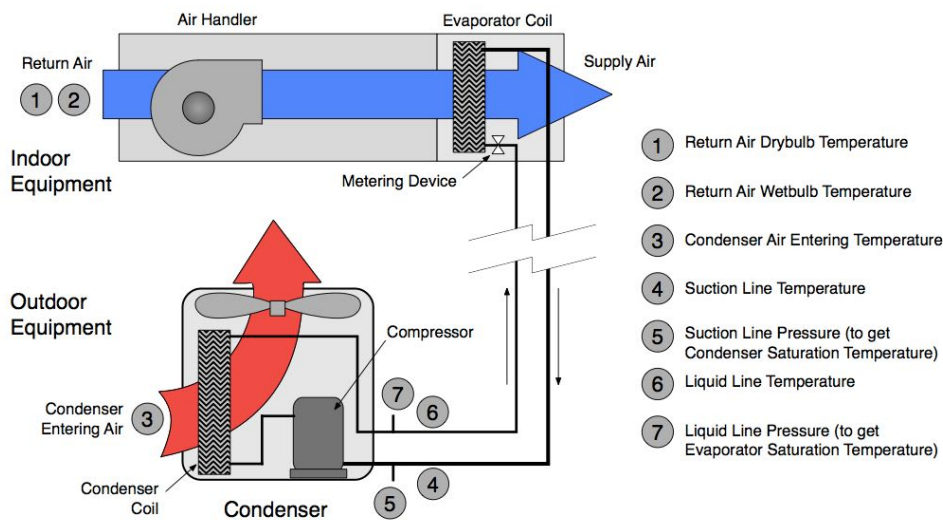

Source: California Energy Commission

The following measurements shall be taken by the technician or HERS Rater, when applicable.

1. The return air wet bulb and dry bulb temperatures are measured in the return plenum before the blower at the location labeled "Title 24 – Return Plenum Measurement Access Hole." This hole must be provided by the installer, not the rater (See Points 1 and 2 in Figure 4-45). See Figure RA 3.2-1 for more information on the placement of the measurement access hole (MAH).
2. Moreover, the outdoor air dry bulb temperature is measured at the point where the air enters the outdoor condensing coil. (See Point 3 in Figure 4-45). It is important that this outdoor temperature sensor be shaded from direct sun during the verification procedure.

In addition to the air temperature measurements, four refrigerant properties need to be measured. Two of these measurements are taken near the suction line service valve before the line enters the outdoor unit and are used to check the superheat.

1. The first measurement is the temperature of the refrigerant in the suction line, which is taken by a clamp-on thermocouple or other suitable device insulated from the outdoor air. (See Point 4 in Figure 4-45.)
2. The second measurement determines the saturation temperature of the refrigerant in the evaporator coil. (See Point 5 in Figure 4-45.) The saturation temperature can be determined from the low-side (suction line) pressure and a saturation temperature table for the applicable refrigerant.

To check the subcooling, two more refrigerant properties are required and may be measured near the liquid line service valve at the point where the line exits the outdoor unit.:



1. The liquid refrigerant temperature in the liquid line is measured by a clamp-on thermocouple insulated from the outdoor air. (See Point 6 in Figure 4-45.)
2. The condenser saturation temperature can be determined from the liquid line pressure and a saturation temperature table for the applicable refrigerant. (See Point 7 in Figure 4-45.)

Determination of the condenser saturation temperature and the liquid line temperature is used only for the subcooling verification method on systems with TXV or EXV metering devices.

**4.8.1.4 Superheat Charge Verification Method (RA3.2.2.6.1)**

The *Superheat Charge Verification Method* is used on units with a fixed refrigerant metering device (not a TXV or EXV).

Airflow verification must be confirmed before starting the Superheat Verification Method.

**Table 4-20: Structure of Target Superheat**

		Return Air Wet-Bulb Temperature (°F)									
		(T Return, wb)									
		50	51	52	53	54	55	--	--	75	76
Condenser Air Dry-Bulb Temperature (°F) (T condenser, db)	55	Target Superheat = Suction Line Temperature minus Evaporator Saturation Temperature  See Reference Residential Appendix Table RA3.2-2									
	56										
	57										
	--										
	--										
	93										
	94										
95											

Source: California Energy Commission

The *Superheat Verification Method* compares the actual (measured) superheat temperature to a target value from a table. The actual superheat temperature is the measured suction line temperature ( $T_{\text{Suction, db}}$ ) minus the evaporator saturation temperature ( $T_{\text{Evaporator, Saturation}}$ ). The target superheat value is read from a table (Table RA3.2-2 of the Reference Residential Appendix or the manufacturer’s superheat table).

For illustration, the structure of Table RA3.2-2 is shown above as Table 4-20.

Only an EPA-certified technician may add or remove refrigerant. Under no circumstances may HERS Raters add or remove refrigerant on systems that they are verifying.

#### 4.8.1.5 Subcooling Verification Method (RA3.2.2.6.2)

The *Subcooling Verification Method* is used on units with a variable refrigerant metering device (a TXV or EXV).

Airflow verification must be confirmed before starting the Subcooling Verification Method.

The Subcooling Verification Method compares the actual subcooling temperature to the target value supplied by the manufacturer. The actual subcooling is the condenser saturation temperature ( $T_{\text{Condenser, Saturation}}$ ) minus the liquid line temperature ( $T_{\text{Liquid}}$ ).

#### 4.8.1.6 Weigh-In Charging Procedure (RA3.2.3)

The weigh-in charging procedure charges the system by determining the appropriate weight of refrigerant based on the size of the equipment and refrigerant lines rather than by measuring steady-state performance of the system. Systems using the weigh-in procedure to meet the refrigerant charge verification requirement may not use group sampling procedures for HERS verification compliance.

The weigh-in procedure does not relieve the installer of the responsibility to comply with the required minimum system airflow.

There are two installer options for completing the weigh-in procedure. One involves adjusting the amount of refrigerant supplied by the manufacturer in a new system, as specified by the manufacturer (weigh-in charge adjustment). The other involves evacuating the entire system and recharging it with the correct total amount of refrigerant, by weight (weigh-in total charge).

The weigh-in charge adjustment procedure may be used only when a new factory-charged outdoor unit is being installed and the manufacturer provides adjustment specifications based on evaporator coil size and refrigerant line size and length.

The weigh-in total charge may be used for any weigh-in procedure but still requires manufacturer's adjustment specifications. Only the installer/technician may perform any kind of weigh-in procedure.

#### 4.8.1.7 Equipment Limitations

The Energy Standards specifically require verification of refrigerant charge only for air-cooled air conditioners and air-source heat pumps. All other types of systems are not expressly exempt from the refrigerant charge requirements. Certain portions of the requirements may still apply, such as the minimum system airflow requirement. The installer would have to verify with the manufacturer and confirm with the Energy Commission. The installer must adhere strictly to the manufacturer's specifications.

Variable refrigerant flow systems and systems such as some mini-split systems that cannot be verified using the standard charge verification procedure in RA3.2.2 must demonstrate compliance using the weigh-in method. Verification by the HERS Rater can be accomplished only by simultaneous observation of the installer's weigh-in as

specified by RA3.2.3.2, and only if use of HERS Rater observation procedure is specified by the Standards.

#### 4.8.1.8 HERS Verification Procedures

When required by the certificate of compliance, HERS Raters must perform field verification and diagnostic testing of the refrigerant charge, including verification of minimum system airflow and verification of installation of the measurement access hole.

The verification procedures are essentially identical for the rater and the installer except that the tolerances for passing the superheat and subcooling tests are less stringent for the rater's test. This is to allow for some variations in measurements due to instrumentation or test conditions (for example, weather).

The following conditions prohibit verification using sample groups:

1. When the weigh-in method is used
2. When the minimum airflow cannot be met despite reasonable remediation attempts. (See RA3.3.3.1.5).

As always, to be eligible for sampling, the installer must first verify and pass the system. If sampling is not being used, the rater will perform the verification only after the installer has charged the system according to manufacturer's specifications.

#### 4.8.1.9 Winter Setup Procedures

Reference Appendix RA1 provides for the approval of special case refrigerant charge verification procedures. These protocols may be used only if the manufacturer has approved use of the procedure for their equipment.

One such procedure is found in RA1.2 Winter Setup for the standard charge verification procedure (winter charge setup). It provides for a modification to the standard charge procedure when temperature conditions do not allow use of the RA3.2.2 standard charge verification procedure.

The winter charge setup allows both installers and HERS Raters to verify the charge when outdoor temperatures are below the manufacturer's allowed temperature, or the outdoor temperature is less than 55°F. The Weigh-in Charging Procedure specified in Section RA3.2.3 may also be used when the outdoor temperatures are below the manufacturer's allowed temperature or below 55°F but may be used only by the installer.

The winter charge setup procedure allows the system to operate in the same range of pressure differences between the low-side pressure and the high-side pressure as occurs during warm outdoor temperatures, by restricting the airflow at the condenser fan outlet. The winter charge setup is used only for units equipped with variable metering devices, which include thermostatic expansion valves (TXV) and electronic expansion valves (EXV) for which the manufacturer specifies subcooling as the means for determining the proper charge for the unit, including units equipped with microchannel heat exchangers. Once this pressure differential is achieved, the

variable metering device calculations are conducted in the same way as the variable metering device procedures described in Reference Residential Appendix RA 3.2.2.6.2. All other applicable requirements of Section RA3.2.2 remain the same and must be completed when using the winter charge setup.

Though not specifically mentioned in the FID protocols in Residential Appendix RA3.4.2, the RA 1.2 winter setup method may be used if applicable. Thus for FID verification, the winter setup method may be used in place of the subcooling method.

**4.8.1.10 Using Weigh-In Charging Procedure at Low Outdoor Temperatures**

When a new HVAC system is installed, the HVAC installer must check the refrigerant charge, and a HERS Rater must verify the correct charge; however, an exception to §150.1(c)7A provides for an alternative third-party HERS verification if the weigh-in method is used when the outdoor temperature is less than 55 degrees F.

Typically, when the weigh-in method is used by the installing contractor, a HERS Rater must perform a charge verification in accordance with the RA3.2. standard charge procedure. However, because the RA3.2.2 procedures cannot be used when the outdoor temperatures are less than 55 degrees, the Energy Standards provide the installer with two choices:

1. Use the RA3.2.3.2 HERS Rater Observation of Weigh-In Charging Procedure to demonstrate compliance and install an occupant-controlled smart thermostat (OCST).
2. Wait for warmer temperatures and perform the standard charge verification procedure. In this case, the installer must agree to return to correct refrigerant charge if a HERS Rater determines later, when the outside temperature is 55 degrees F or above, that correction is necessary as described in Residential Appendix RA 2.4.4. The installer must also provide written notice to the homeowner that the charge has not yet been verified. An example homeowner’s notification is shown in Figure 4-46.

**Figure 4-46: Example of Notification to Homeowners of Delayed Charged Verification**

**Note to Homeowner: We’re not done yet!**

Congratulations on your new Air-Conditioning system! Your new system is much more efficient than older systems, and it has been installed to industry guidelines, ensuring many years of comfort and efficient service.

One thing you need to know, however, is that the installation process is not complete! Because your unit was installed when the outside air temperature was too low to fine tune the air conditioner, the unit must be serviced and verified when the weather is warmer.

This requires your cooperation. You need to allow access to the unit for your Installer and/or HERS Rater (verifier) to verify that the refrigerant charge and airflow are set correctly. Your project is not considered finished until this verification takes place. If it is not done, **your unit may cost more to operate, may not heat and cool as effectively, and may not last as long.**

You will be contacted within the next few months to schedule this service. If you do not hear something after a few months of warmer weather, please contact your Installer. Enjoy your new system!

Source: California Energy Commission

## 4.9 Compliance and Enforcement

This section describes compliance documentation and field verification requirements related to heating and cooling systems.

### 4.9.1 Design-Phase Documentation

The initial compliance documentation consists of the certificate of compliance (CF1R). It lists the features that the house needs for compliance with the prescriptive or performance requirements.

For the prescriptive compliance approach, the required features are based on the Prescriptive Component Package, shown in Table 150.1-A or 150.1-B.

For the performance compliance approach, the required features are based on a set of features that the designer has documented to result in a level of efficiency at least as good as the prescriptive component package for single-family and multifamily. The calculations for documenting this are done using the approved performance compliance software. The calculation approach is described in the *Alternative Calculation Method (ACM) Reference Manual*.

The performance compliance approach provides maximum design flexibility. It also allows compliance credit for special additional features to be quantified.

The CF1R has a section where special modeling features are listed. These are features for which special compliance credit was taken using the performance approach. They require additional visual verification by the enforcement agency to ensure proper installation. Some require field verification and diagnostic testing by a HERS Rater. These will be listed in a separate section.

The following are heating and cooling system features that will be listed in this section if they exist in the proposed design:

Special Features Not Requiring HERS Rater verification:

1. Ducts in a basement
2. Ducts in a crawlspace
3. Ducts in an attic with a radiant barrier
4. Hydronic heating and system design details
5. Gas-fired absorption cooling
6. Zonal control
7. Ductless wall heaters

Special features requiring HERS Rater verification:

1. Duct sealing
2. Verified duct design – for reduced duct surface area and ducts in conditioned space

3. Low-leakage ducts in conditioned space
4. Low-leakage air handlers
5. Verification of return duct design
6. Verification of air filter device design
7. Verification of bypass duct prohibition
8. Refrigerant charge verification
9. Installation of a fault indicator display (FID)
10. Verified system airflow
11. Air handler fan watt draw
12. High energy efficiency ratio (EER)
13. Verified seasonal energy efficiency ratio (SEER)
14. Heating seasonal performance factor (HSPF)
15. Heat pump - rated heating capacity
16. Continuous dwelling unit mechanical ventilation airflow for IAQ
17. Intermittent dwelling unit mechanical ventilation airflow for IAQ
18. Kitchen range hood verification for IAQ
19. Building or dwelling unit enclosure air leakage
20. Quality insulation installation (QII)
21. Whole-house fan airflow and fan efficacy
22. Central fan ventilation cooling system verification

Information summarizing measures requiring field verification and diagnostic testing is presented in Table RA2-1 of the Reference Residential Appendix RA2. The field verification and diagnostic testing protocols that must be followed to qualify for compliance credit are described in RA3 of the Reference Residential Appendix.

Registration of the CF1R with an approved HERS Provider is required. The building owner or the person responsible for the design must submit the CF1R to the HERS Provider Data Registry for retention according to the procedures described in Section 10-103, and Section RA2 of the Reference Residential Appendix.

Registration ensures that the project follows the appropriate verification process, provides tracking, and provides electronic access to the documentation.

#### **4.9.2 Construction-Phase Documentation**

During construction, the general contractor or specialty subcontractors must complete all applicable certificate of installation (CF2R) documents for the building design special features specified on the certificate of compliance (CF1R).

Like the CF1R, registration of the CF2R is required. The licensed contractor responsible for the installation must submit the CF2R information that applies to the installation to a HERS Provider Data registry using procedures described in Section 10-103, and Section RA2 of the Reference Residential Appendix. CF2R documents corresponding to the list of special features requiring HERS Rater verification in Section 4.9.1 above are required.

### **4.9.3 Field Verification and/or Diagnostic Testing**

For buildings for which the certificate of compliance (CF1R) requires HERS field verification for compliance with the Energy Standards, a HERS Rater must visit the site to perform field verification and diagnostic testing to complete the applicable heating and cooling system certificates of field verification and diagnostic testing (CF3R). CF3R documents corresponding to the list of special features requiring HERS Rater verification in Section 4.9.1 above are required

Field verification for nonmandatory features is necessary only when performance credit is taken for the measure. Some field verification is for mandatory measures and will occur in all homes, unless they are exempt from the measure.

Like the CF1R and CF2R, registration of the CF3R is required. The HERS Rater must submit the field verification and diagnostic testing information to the HERS Provider Data Registry as described in Chapter 2. For additional details describing HERS verification and the registration procedure, refer to RA2 of the Reference Residential Appendix.