

INSTALLATION INSTRUCTIONS

ECONOMIZER

MODEL ECW-2, 3&4

FOR USE WITH BARD HI-BOY AIR CONDITIONERS AND HEAT PUMPS

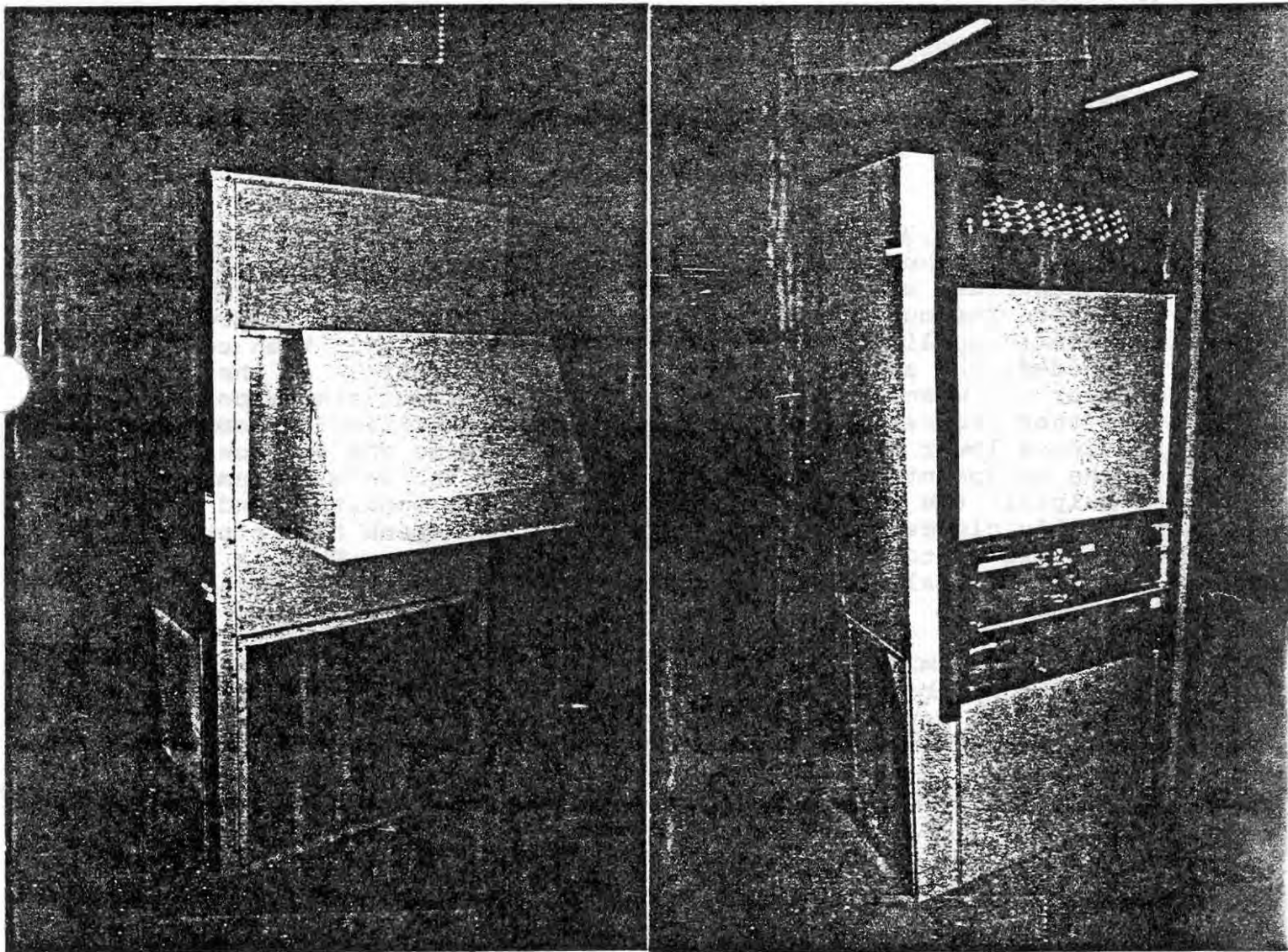

INSTALLATION INSTRUCTIONS  
FOR

ECONOMIZER MODELS ECW-2,3&4 FOR USE WITH BARD  
HIGH BOY AIR CONDITIONERS AND HEAT PUMPS

GENERAL INFORMATION

The economizer should only be installed by a trained heating and air conditioning technician. These instructions serve as a guide to the technician installing the economizer package. They are not intended as a step by step procedure with which the mechanically inclined owner can install the package.

UNPACKING

Upon receipt of the equipment, the cartons should be checked for external signs of shipping damage. If damage is found, the receiving party must contact the last carrier immediately, preferably in writing, requesting inspection by the carrier's agent.

DESCRIPTION

The ECW-2,3&4 economizers are designed to be used with Bard Hi-Boy series heat pumps and air conditioners. They are electrical mechanical economizer systems designed to provide "free" cooling where the outdoor air temperature is cool enough to provide the needed cooling without running the compressor. When cooling is needed, the system automatically takes advantage of the cold outdoor air when available and uses it for first stage cooling. This then reduces the need to run the air conditioning compressor providing lower operating costs and increasing the service life of the equipment. If the outdoor air gets too warm or humid to be helpful, the enthalpy control detects the condition and automatically closes the outdoor air damper and opens the return air damper and switches to the compressor operation. This is all done automatically to achieve maximum savings without attention from the user.

The economizer is shipped in one carton which contains the intake hood subassembly, return damper subassembly, damper cross link, blower cover panel subassembly, electrical access panel subassembly, miscellaneous screws and installation instructions. The exhaust air damper assembly is an option and is both ordered and shipped separately.



# ECONOMIZER

Factory Built - Field Installed For  
Bard Wall Mount Air Conditioners and Heat Pumps

## PRELIMINARY SPECIFICATIONS

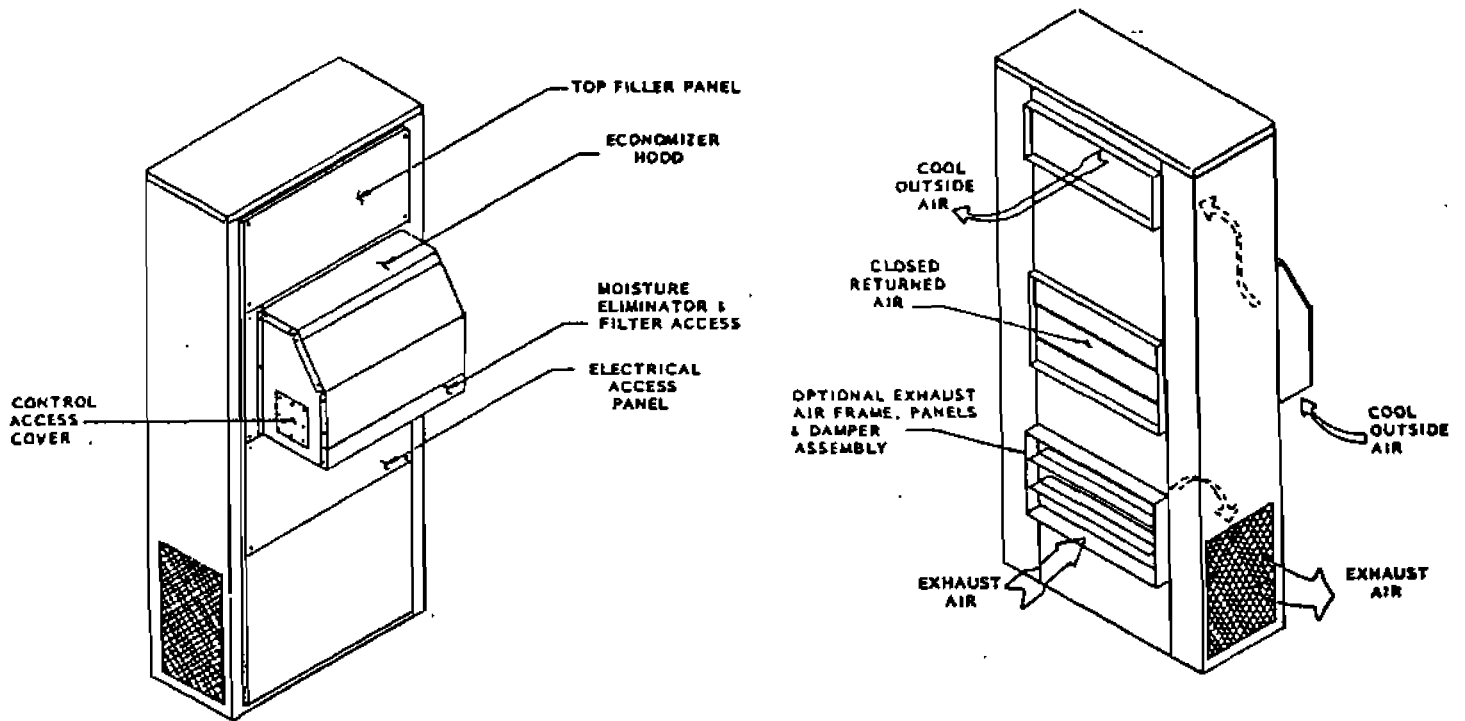

## STANDARD FEATURES

PROPORTIONING TYPE CONTROL for maximum "Free Cooling" economy and comfort with up to 100% outdoor air.

PLEATED AIR FILTER to provide maximum filtration of outside air.

MOISTURE ELIMINATOR AND PRE-FILTER - permanent, washable aluminum construction.

ADJUSTABLE LOW TEMPERATURE COMPRESSOR CUTOFF - factory built in - eliminates need for field added low ambient control.

ENTHALPY CONTROL to monitor outdoor temperature and humidity - adjustable.

MINIMUM POSITION POTENTIOMETER - adjustable to control minimum damper blade position.

MIXED AIR SENSOR to monitor outdoor and return air to automatically modulate damper position.

"PLUG-IN" WIRING HARNESS for easy installation and service.

New DAMPER ACTUATOR MOTOR with spring return. Low current draw - eliminates need to change to larger 24 volt transformer.

GASKETED DAMPERS for minimum air leakage. This saves energy by minimizing outside air leakage into the unit when the dampers are closed.

### EASY TO SERVICE

- Economizer controls - easily accessible for adjustment and service.
- Basic air conditioner and heat pump unit controls and compressor remain unobstructed and accessible.

### 2 STAGE COOLING THERMOSTAT

## OPTIONAL FEATURES

EXHAUST AIR DAMPER ASSEMBLY - damper assembly - field installed; provides exhaust air capability to prevent pressurization of tight buildings.

# DIMENSIONS

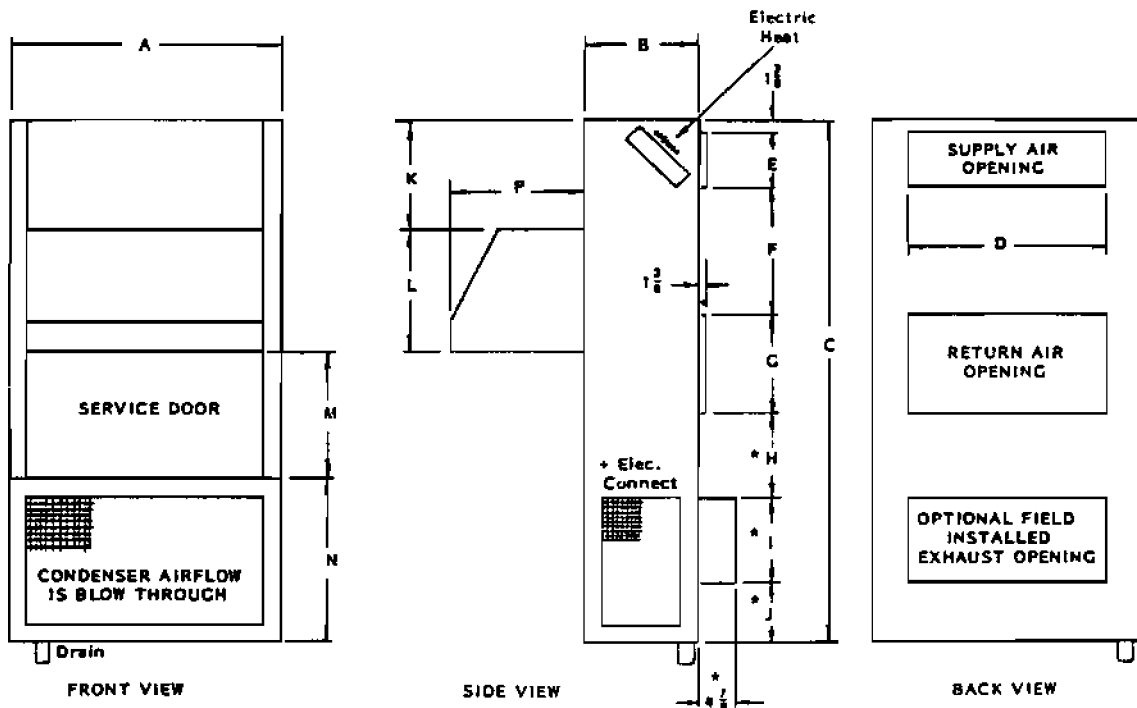

BASIC MODEL	A	B	C	D	E	F	G	H*	I*	J*	K	L	M	N	P	Moisture Eliminator	OD Air Filter
20WA, 24WA, 18WH, 24WH	32 1/4	13 1/2	69 1/2	20	8	20 1/2	12	9	12	6 1/2	16 1/8	15 1/2	16 3/16	20 7/8	12 3/4	8 7/8 x 24 1/2	10x25
30WA, 36WA, 30WH, 36WH	38 1/4	15 1/2	74	28	8	18	14	12	12	8 1/2	14 7/8	17	18 1/2	23 1/2	19	12 1/2 x 29	16x25
42WA, 48WA, 48WH	42	22	84	30	10	30	16	7 1/2	12	7	16 5/8	21 1/2	14	31 5/8	19	12 1/2 x 32 1/2	16x34

Dimensions and filter sizes are in inches.

\*Optional: For exhaust air damper assembly.

## SEQUENCE OF OPERATION

### CONDITION A — COOL OUTDOORS

1st stage cooling closes and powers the economizer dampers to economizer mode and the indoor blower starts. Mixed Air Sensor (thermistor) senses a mixture of return air and outdoor air and modulates the dampers accordingly. Compressor operation is inhibited.

If second stage closes on the thermostat, the dampers return to the closed or minimum position setting and the compressor starts for mechanical cooling.

Compressor lockout thermostat is factory set at 50°F O.D. temperature (adjustable).

### CONDITION B — WARM OUTDOORS

1st stage cooling cycles the compressor and dampers remain in the mechanical cooling mode.

## WALL THERMOSTATS

For Air Conditioning

Thermostat, Part No. 8403-021  
(Honeywell T874D1009)  
Subbase, Part No. 8404-012  
(Honeywell Q674A1001)  
2 Stage Cool/2 Stage Heat

For Heat Pumps

Thermostat, Part No. 8403-023  
(Honeywell T8300B1027)  
Subbase, Part No. 8403-015  
(Honeywell Q6300B1000)  
Low Ambient Control, #LAC-1  
Relay #8201-008  
Electronic Heat Pump Thermostat  
2 Stage Cool/2 Stage Heat

## ORDERING INFORMATION

Basic A/C or H/P Model	Economizer Package	Optional Exhaust Damper Assembly
20WA, 24WA, 18WH, 24WH	ECW-2	ED-2
30WA, 36WA, 30WH, 36WH	ECW-3	ED-3
42WA, 48WA, 48WH	ECW-4	ED-4

Specifications subject to change without notice.



**BARD MANUFACTURING COMPANY**

Dependable quality equipment... since 1914  
BRYAN, OHIO 43506

## BASIC INSTALLATION

1. Unpack the economizer assembly which includes the outside air intake hood assembly, blower cover panel, electrical access panel, return air damper assembly, damper cross link rod and electrical harness & miscellaneous screws.  
(SEE FIGURE 1)

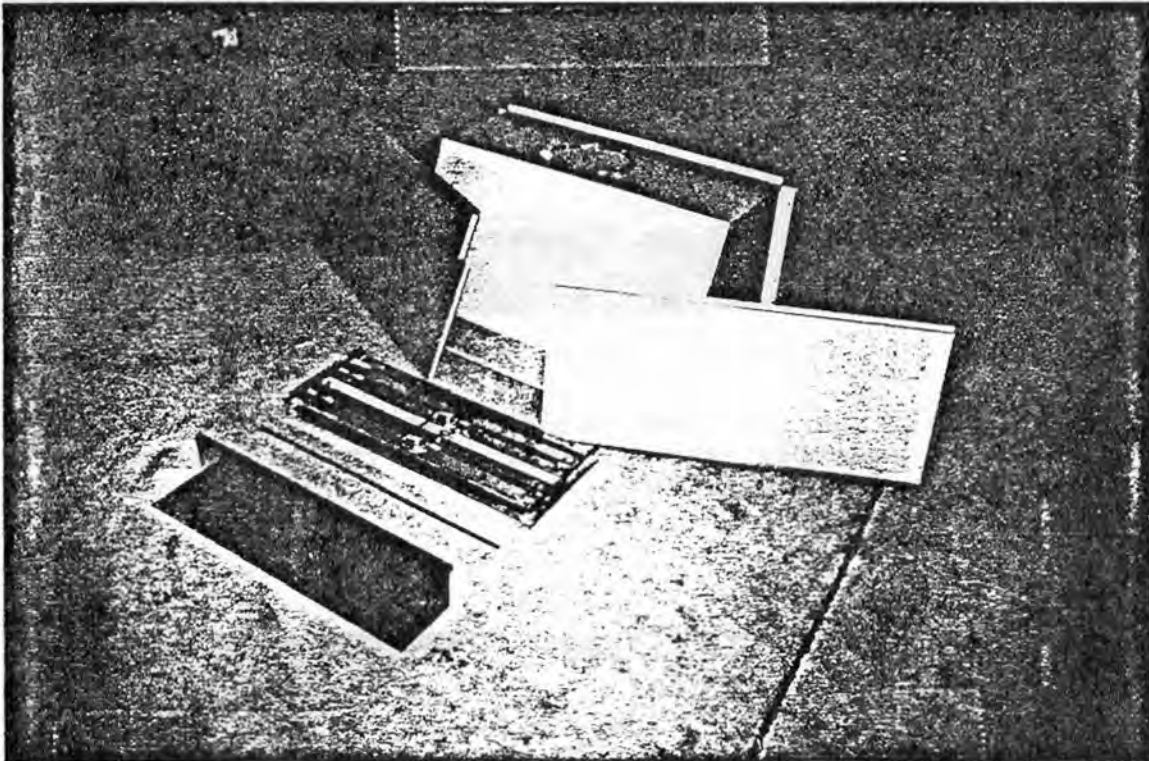

FIGURE - 1

2. Remove the existing exterior fan access and service access panels on the Bard High-Boy units.  
(SEE FIGURE 2)
3. Remove & discard existing unit return air filter.  
NOTE: Economizer installation requires a field supplied and installed return air filter and filter grill. Fresh air is filtered internally by economizer.

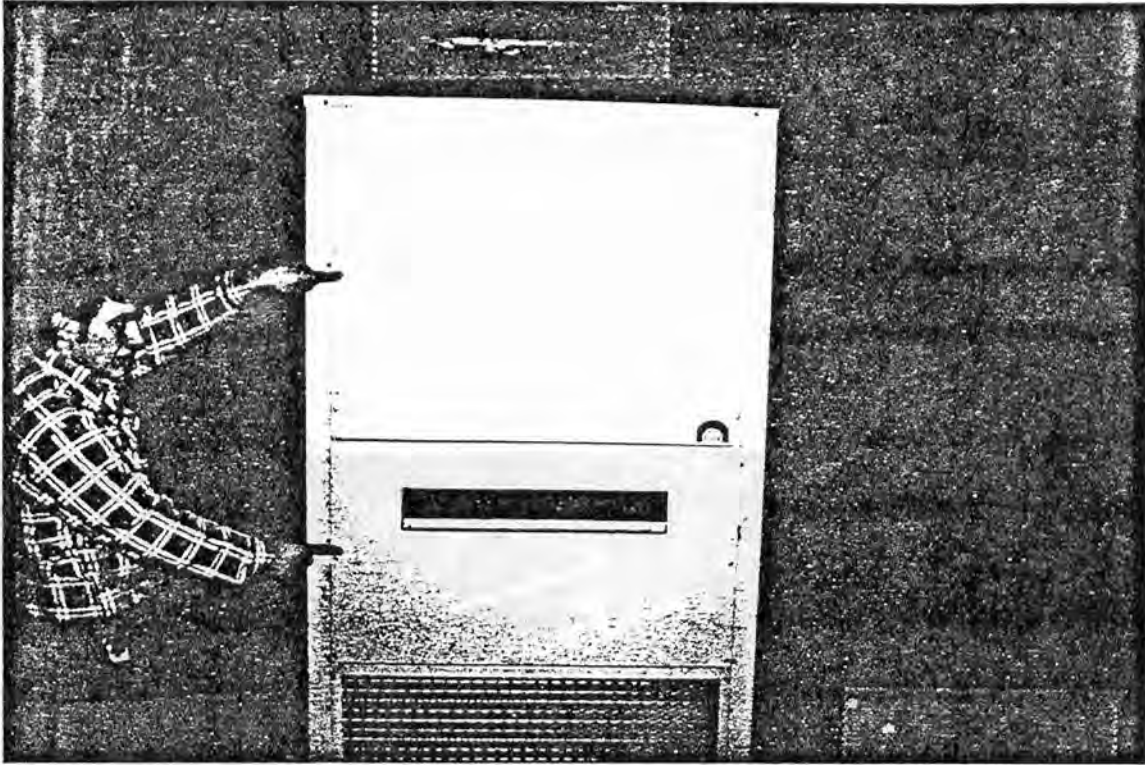

FIGURE - 2

4. Connect the mixed air thermistor sensor to the outside air intake hood assembly to position it in the air stream with the screws and brackets provided. (SEE FIGURE 3)

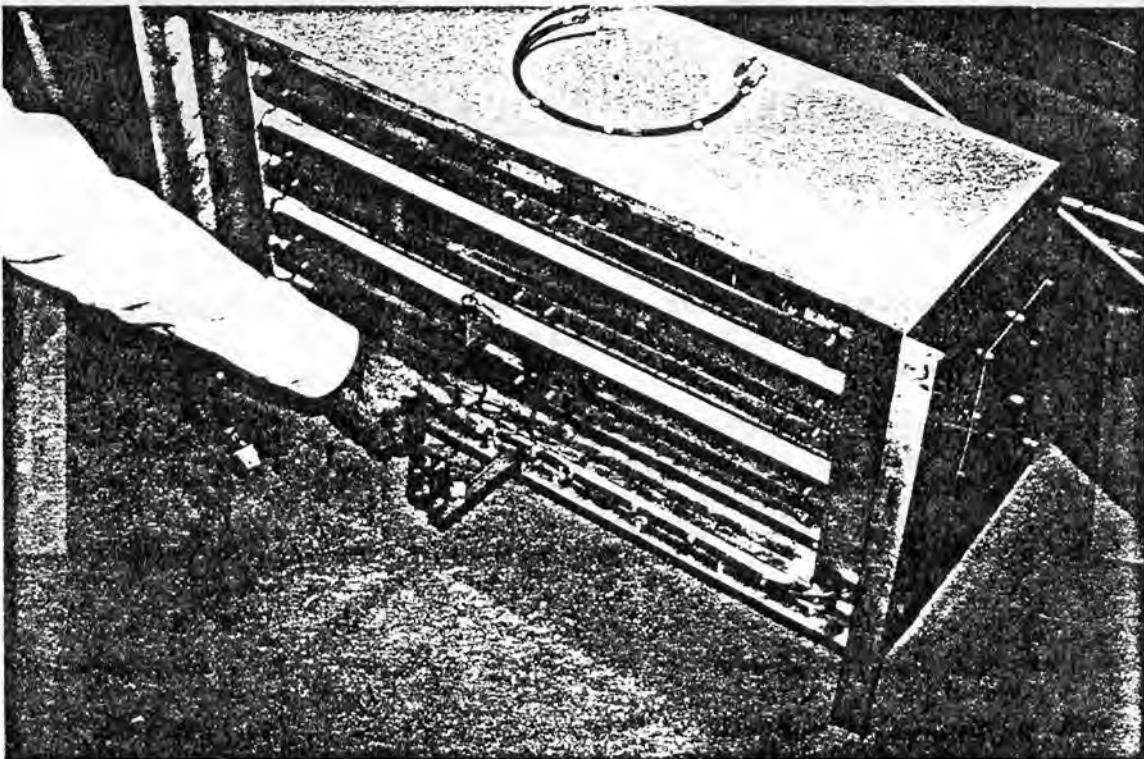

FIGURE 3

5. Attach the damper cross drive link rod to the ball swivel on the fresh air intake damper and tighten securely. (SEE FIGURE 4)

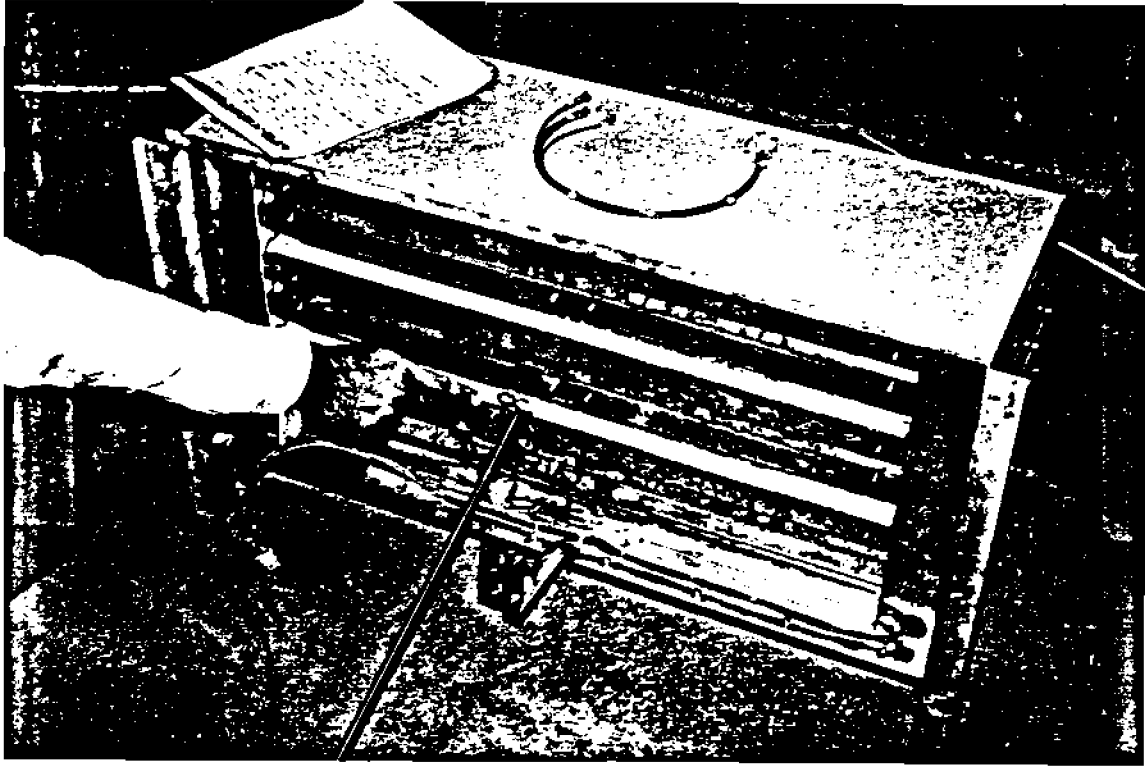

FIGURE - 4

6. Thread the leads of the female portion of the electrical harness thru the bulkhead fitting of the compressor cover into the electrical control panel portion of the Hi-Boy unit. Connect the numbered leads to the corresponding point in the unit terminal block. (SEE FIGURE 5)

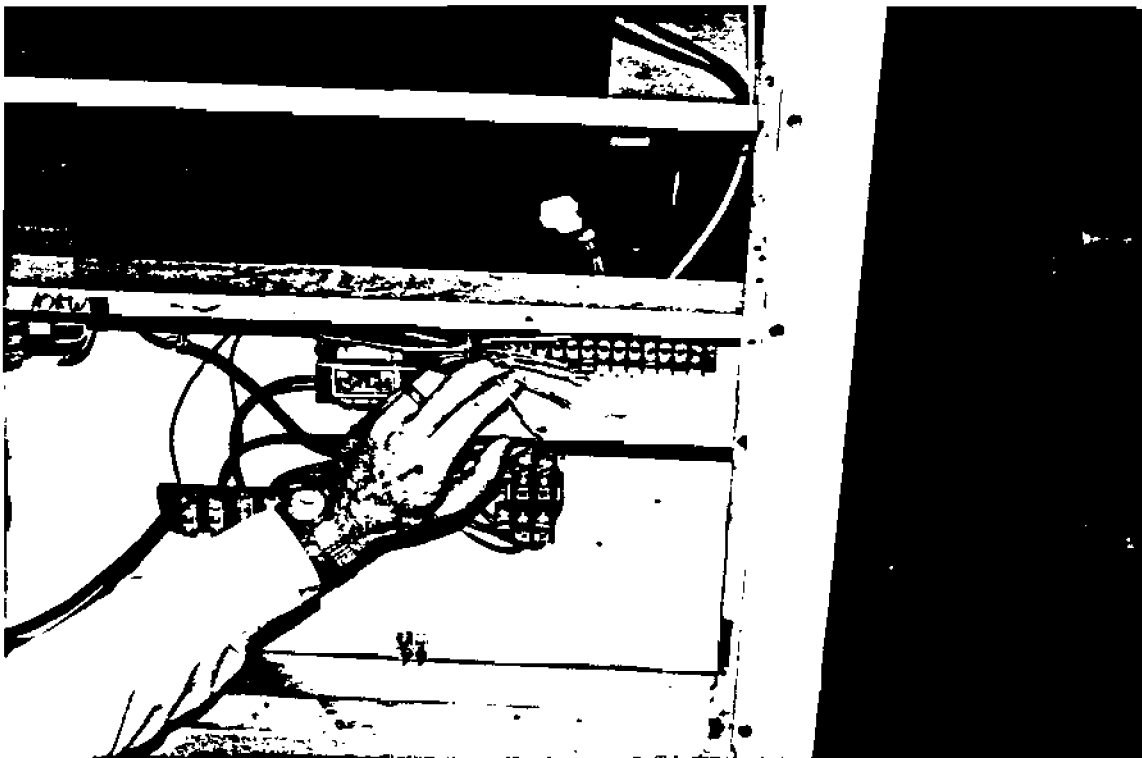

FIGURE 5

7. Install the new blower cover panel at top of unit with screws. Position the fresh air intake hood on the unit. Thread the male harness, mixed air sensor and the damper cross drive link thru the unit between the fans. Take care not to bump the thermistor sensor. Secure the assembly to the unit with the provided self drilling sheet metal screws thru the clearance holes in the side flanges. (SEE FIGURE 6)

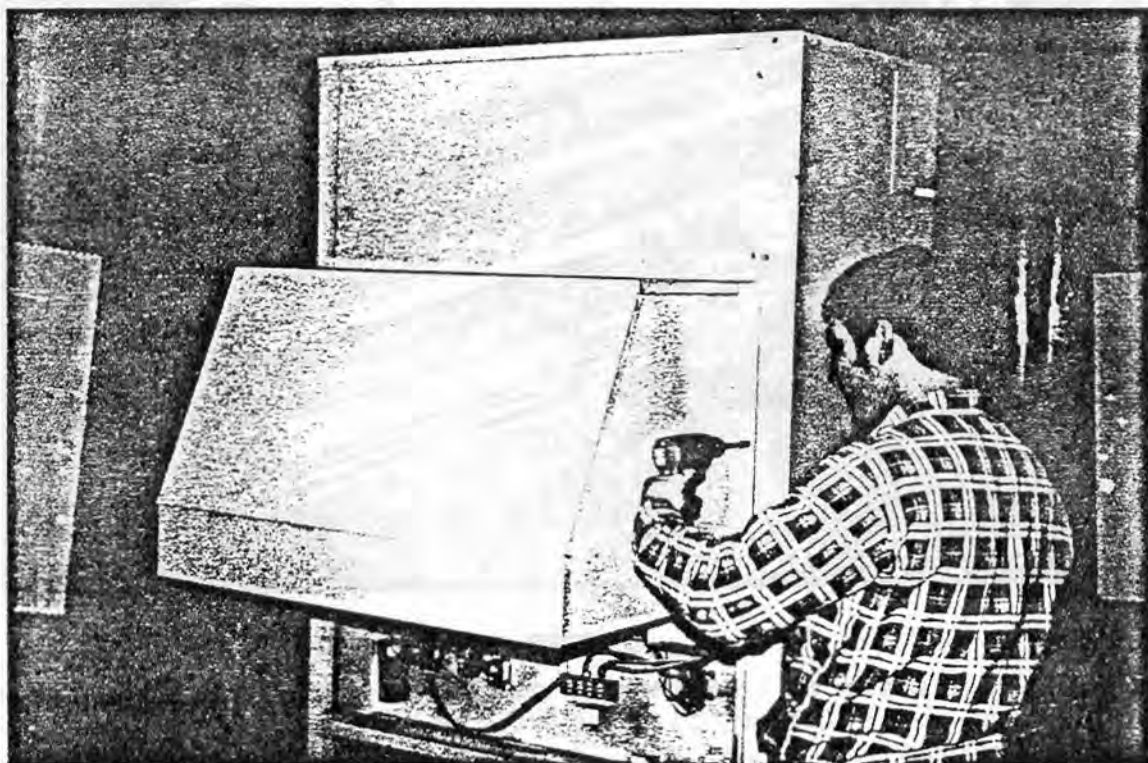

FIGURE - 6

8. Connect the male and female portions of the harness together by reaching thru the opening in the unit under the hood. (SEE FIGURE 7)



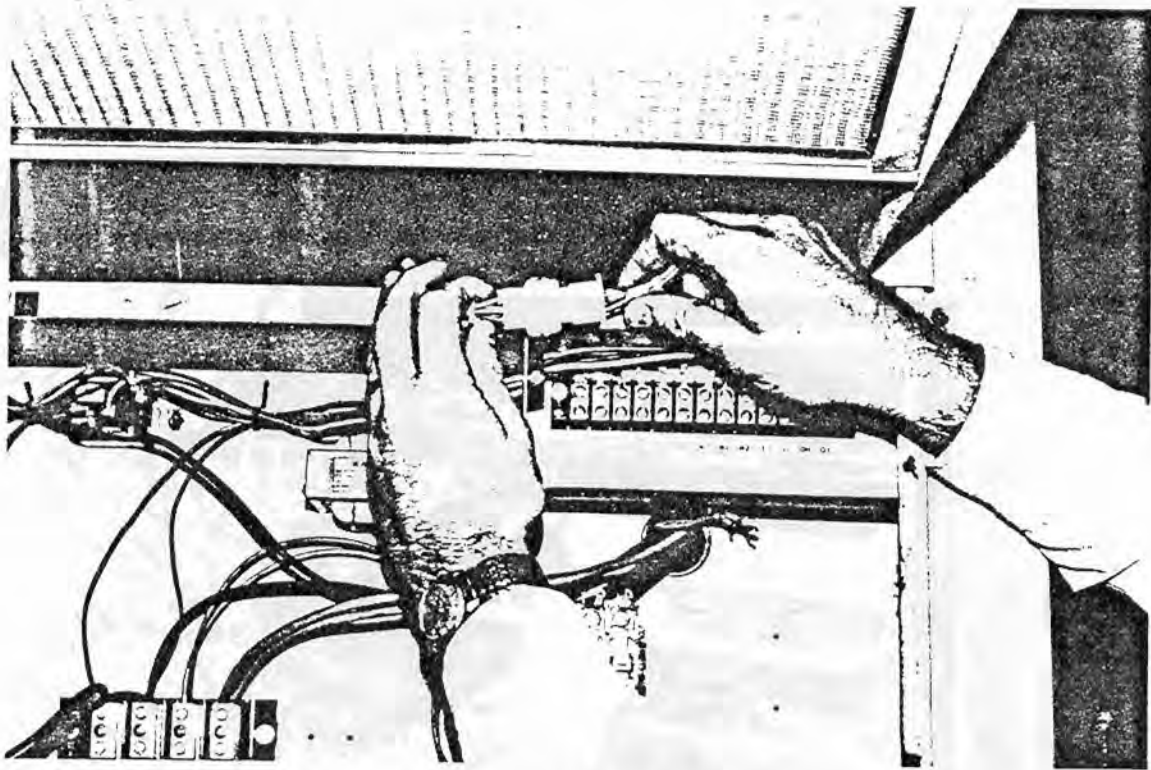

FIGURE - 7

9. Install the return air damper in the return air opening of the Bard unit and secure with sheet metal screws thru the side flanges of the return air duct collar into the damper frame. The damper frame should be flush with the edge of the collar. (SEE FIGURE 8)



FIGURE - 8

10. Attach the damper cross link to the vacant ball swivel on the return air damper drive bracket so that the return air damper is fully open when the unit is off. (ie) The outside air damper is fully closed. (SEE FIGURE 9)

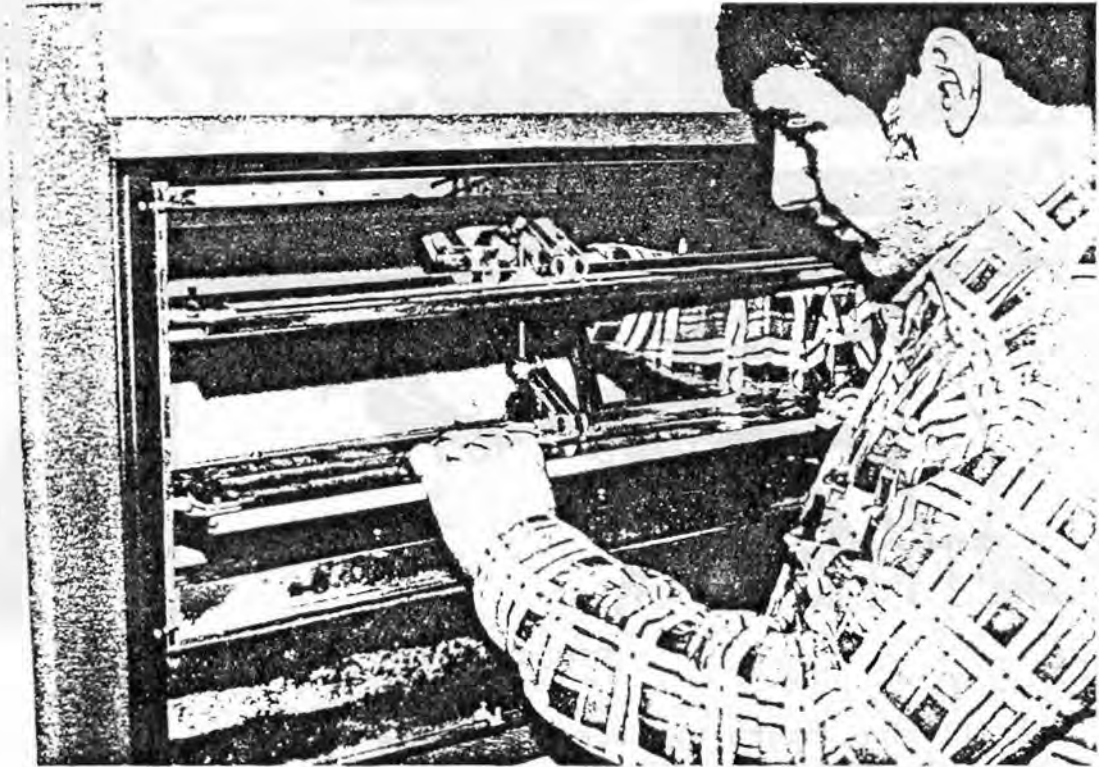

FIGURE - 9

11. Install the old interior electrical cover panel and new electrical access panel on Bard unit with screws. (SEE FIGURES 10 & 11)

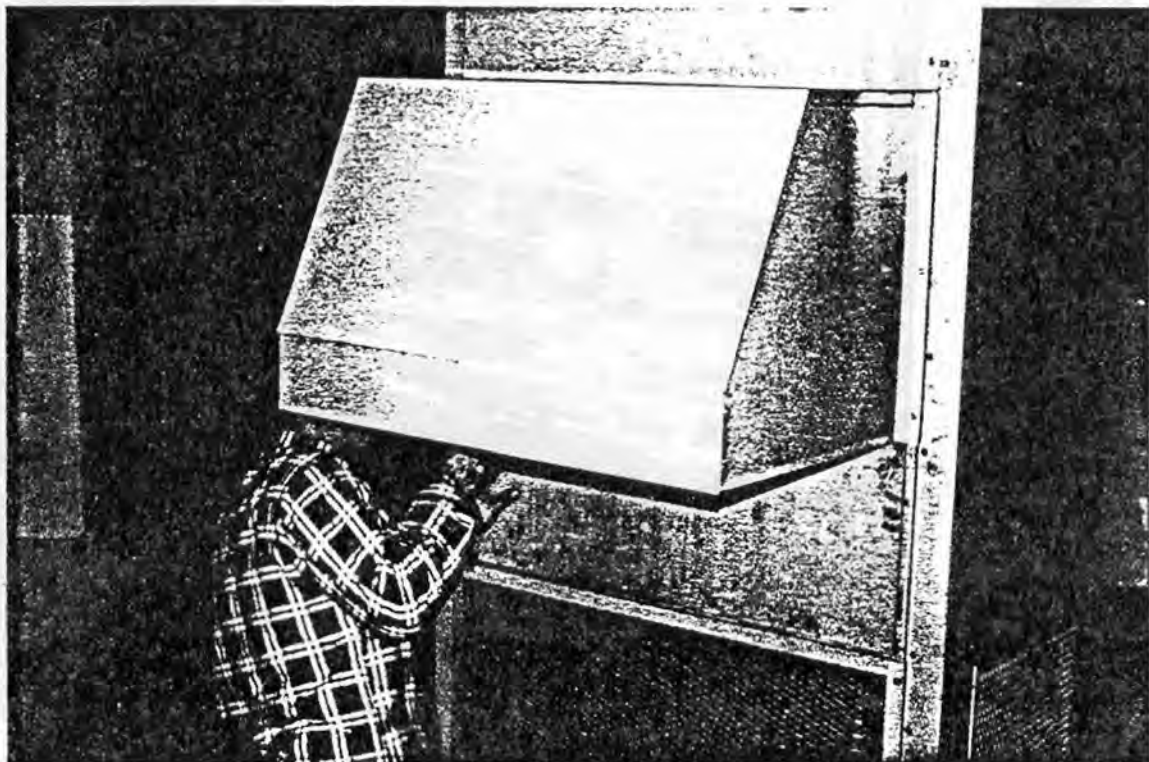

FIGURE - 10

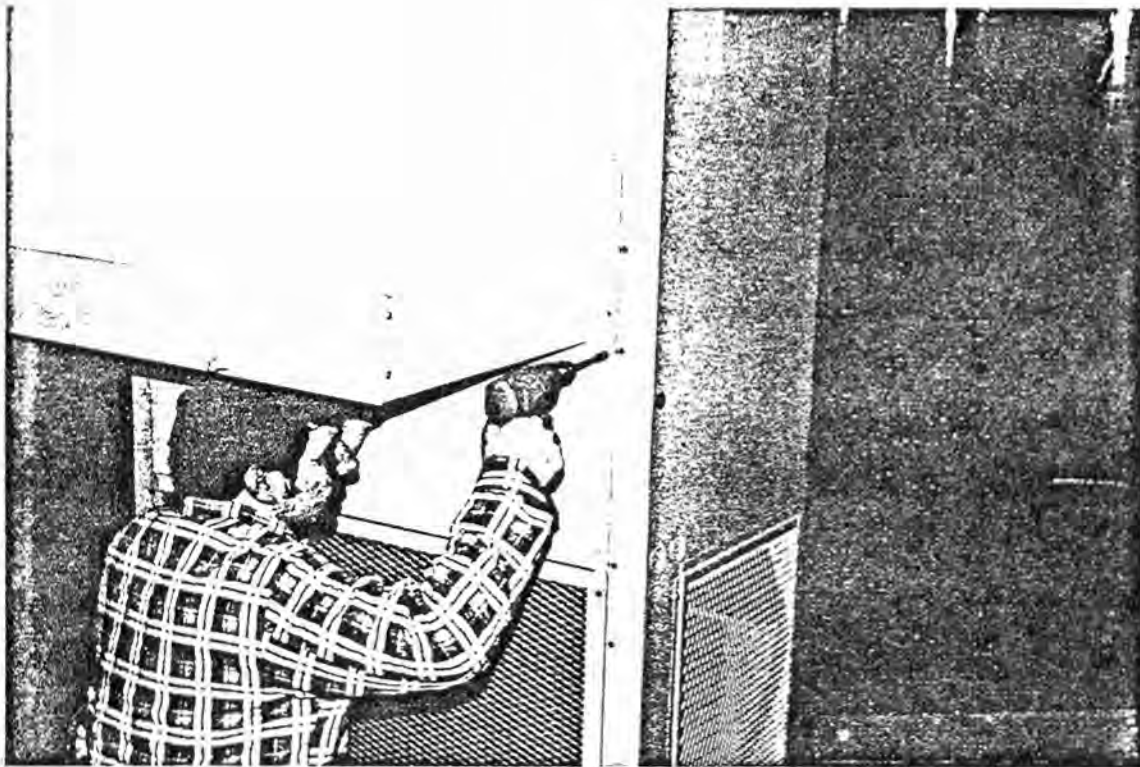
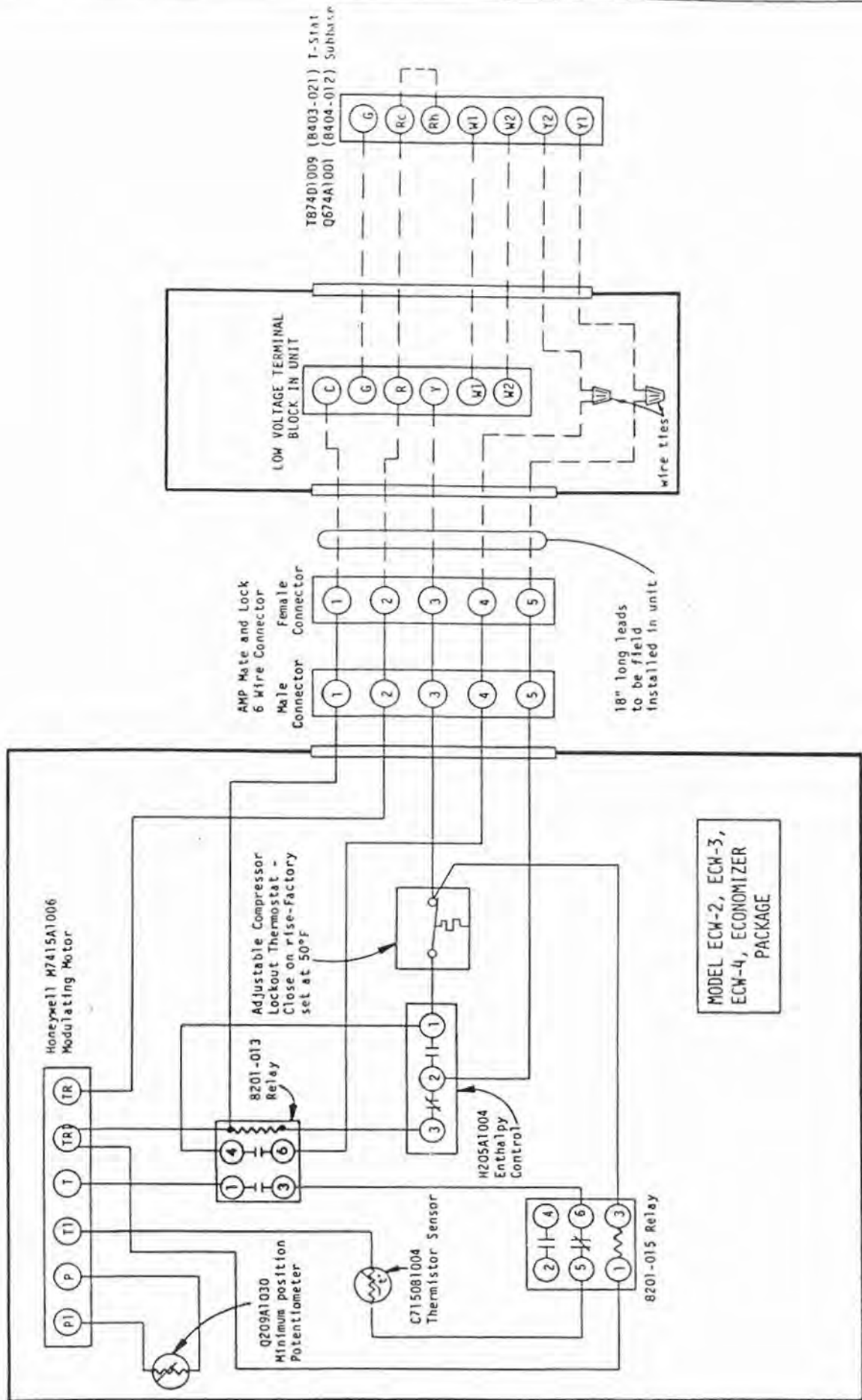

FIGURE - 11

12. Wire the thermostat and subbase as shown on the diagram.  
(SEE SCHEMATICS PAGE 12&13)
- 13a. Remove the field adjustment economizer control access panel on the side of the outside air intake hood assembly. (SEE FIGURE 12.) Adjust enthalpy control at maximum combination of temperature and humidity considered acceptable for the installation as per chart by turning knob to A,B,C, or D.  
(SEE CHART I & II)
- b. Set compressor lockout control thermostat to 50°F by adjusting the knob on the bimetal thermostat. This will inhibit the compressor from running in outdoor ambient temperatures below 50° to prevent the possibility of freezing the indoor coil.
- c. Adjust minimum position potentiometer to insure proper amount of fresh air intake to meet local codes or installation criteria with screw driver. (SEE FIGURE 13)
14. Replace economizer control access cover and secure with screws.
15. Caulk all exterior seams to insure weather tight integrity.  
(SEE FIGURE 14)
16. Unit is now ready for operation.



24V Factory Wiring ———  
 24V Field Wiring - - - -

AIR CONDITIONER CONNECTION DIAGRAM

MODEL ECW-2, ECW-3,  
 ECW-4, ECONOMIZER  
 PACKAGE

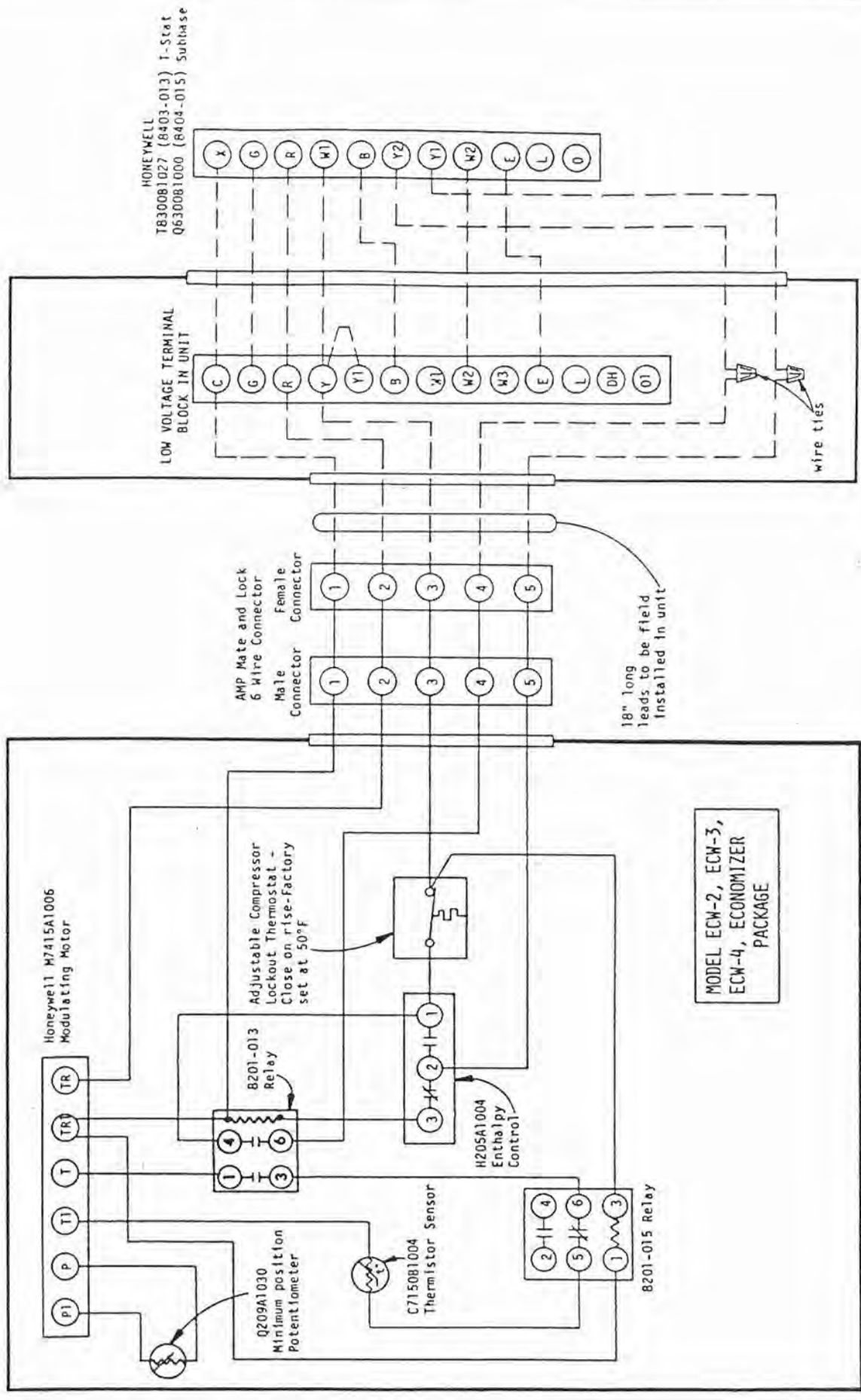

HEAT PUMP CONNECTION DIAGRAM

24V Factory Wiring ———  
 24V Field Wiring - - - -

# CHART I

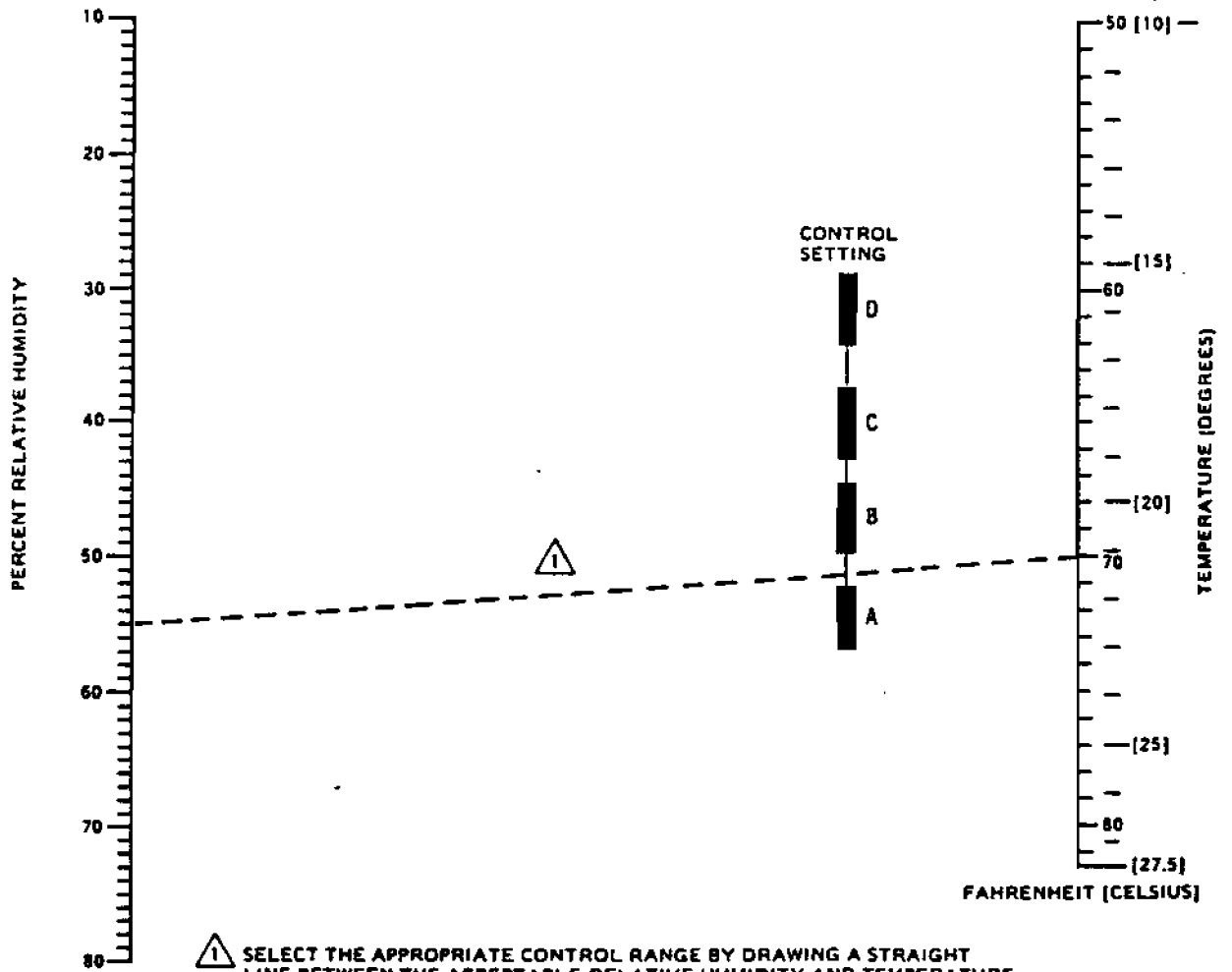

**1** SELECT THE APPROPRIATE CONTROL RANGE BY DRAWING A STRAIGHT LINE BETWEEN THE ACCEPTABLE RELATIVE HUMIDITY AND TEMPERATURE FOR INSTALLATION. ADJUST DIAL TO CONTROL SETTING INDICATED.

# CHART II

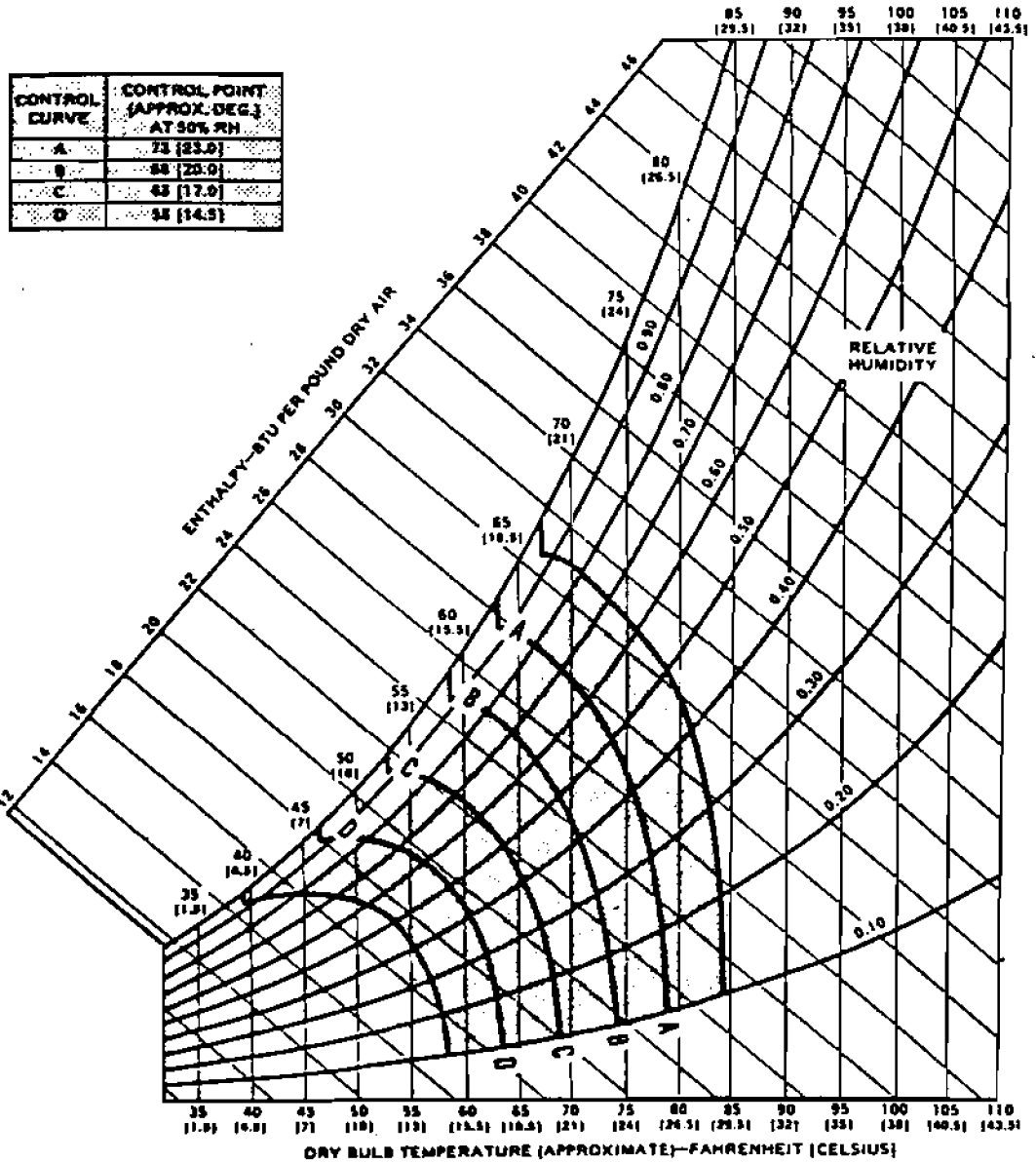

PARTIAL PSYCHROMETRIC CHART WITH PERFORMANCE CURVES SUPERIMPOSED. SHADED AREA REPRESENTS CONTROL RANGE. CURVES ILLUSTRATE RESET IN TEMPERATURE CONTROL POINT DUE TO CHANGES IN RELATIVE HUMIDITY.



FIGURE 12

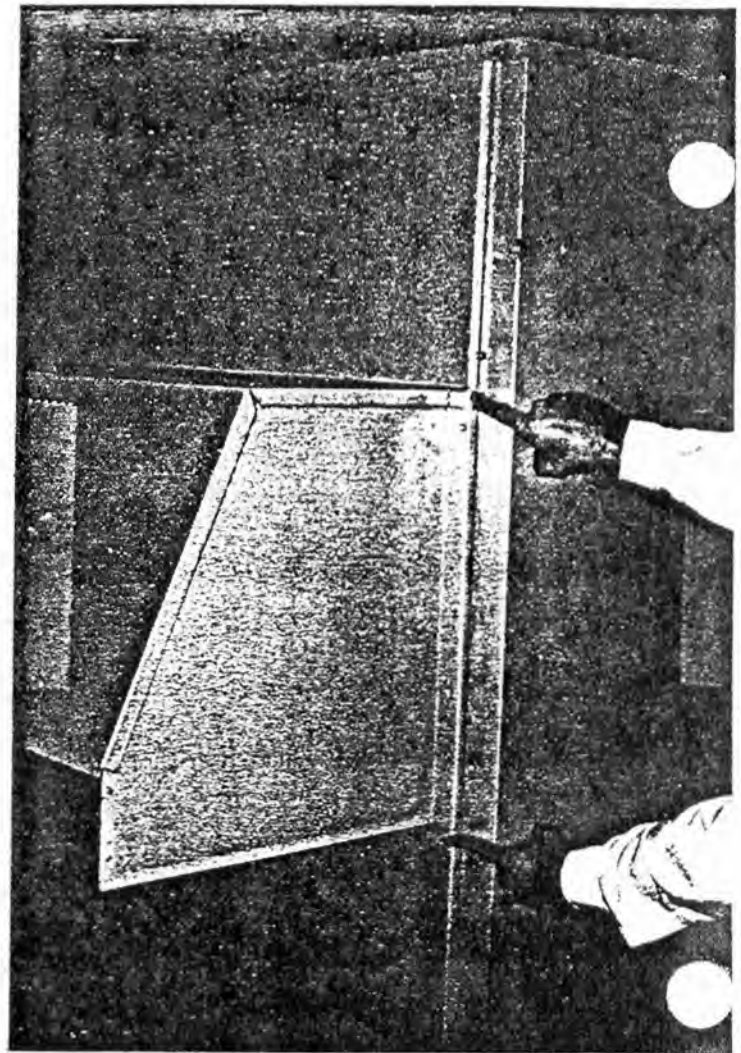

FIGURE 14



FIGURE 13





## FILTER SERVICE

All Bard Hi-Boy economizers come equipped with dual filtration. Primary filtration and mist elimination is accomplished by a 1" thick permanent washable aluminum pre-filter. Secondary filtration is provided by a throw-a-way 1" thick pleated cartridge filter. Access for removal, cleaning and replacement of this filter is thru the bottom front of the intake hood subassembly. Remove the screws on the sides of the filter lower panel of the hood. (SEE FIGURE 15.) Remove the filter lower panel and slide the filters out of their racks for cleaning and replacement. (SEE FIGURE 16.) Replacement cartridges are available from your Bard dealer and are sized as follows:

<u>UNIT</u>	<u>NOMINAL FILTER DIMENSIONS</u>
ECW-2	1" X 10 X 25
ECW-3	1" X 16 X 25
ECW-4	1" X 16 X 34

Replace filters in their respective racks taking care to place them corresponding to air flow and with the drain holes of the moisture eliminator at the lower end of the rack. Replace the filter cover panel and secure with screws.

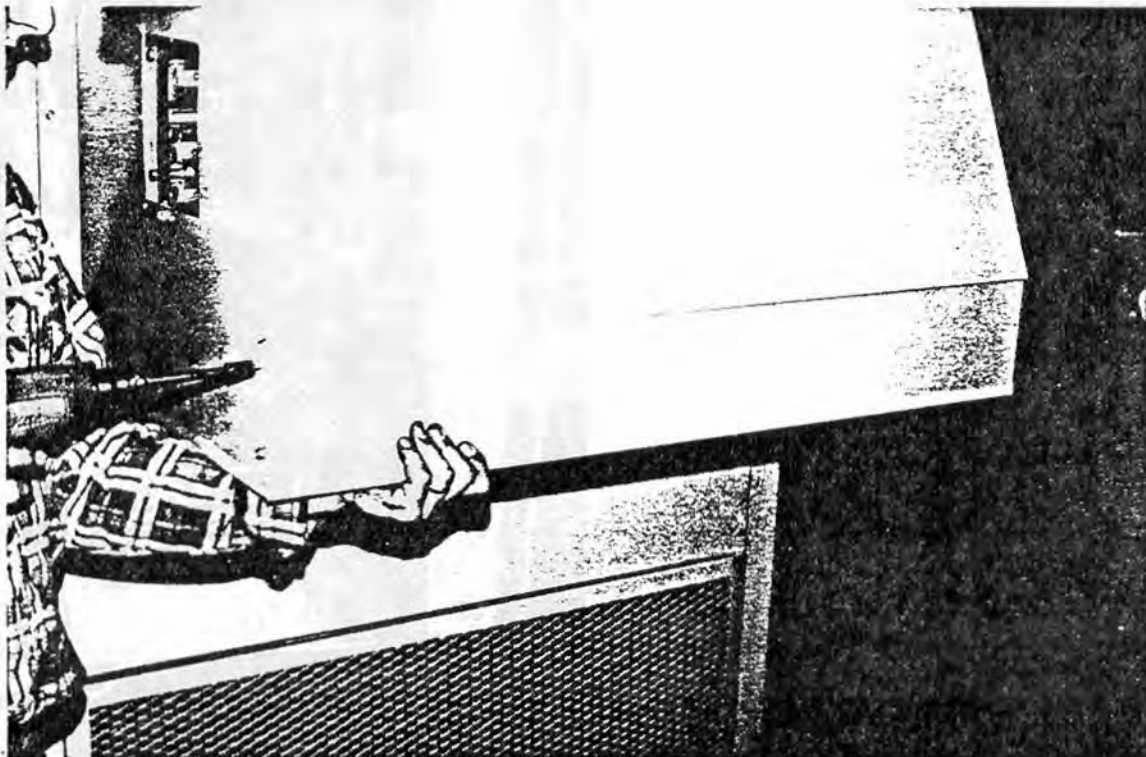
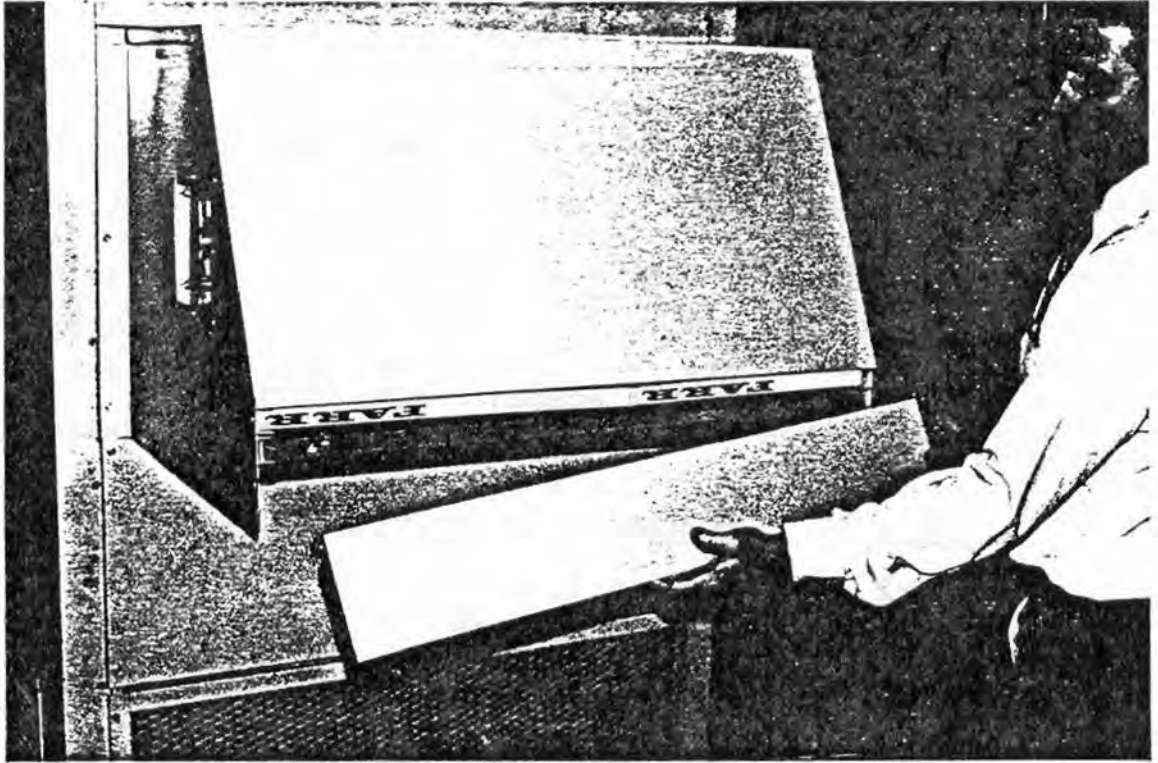

FIGURE - 15

FIGURE 16



DAMPER MOTOR SERVICE

Access for service or replacement of the damper motor can be achieved by removing the front filter panel and filters (SEE FILTER SERVICE.) This exposes all the control components in the intake hood assembly. Drive linkage adjustments can also be made in this manner. (SEE FIGURE 17)

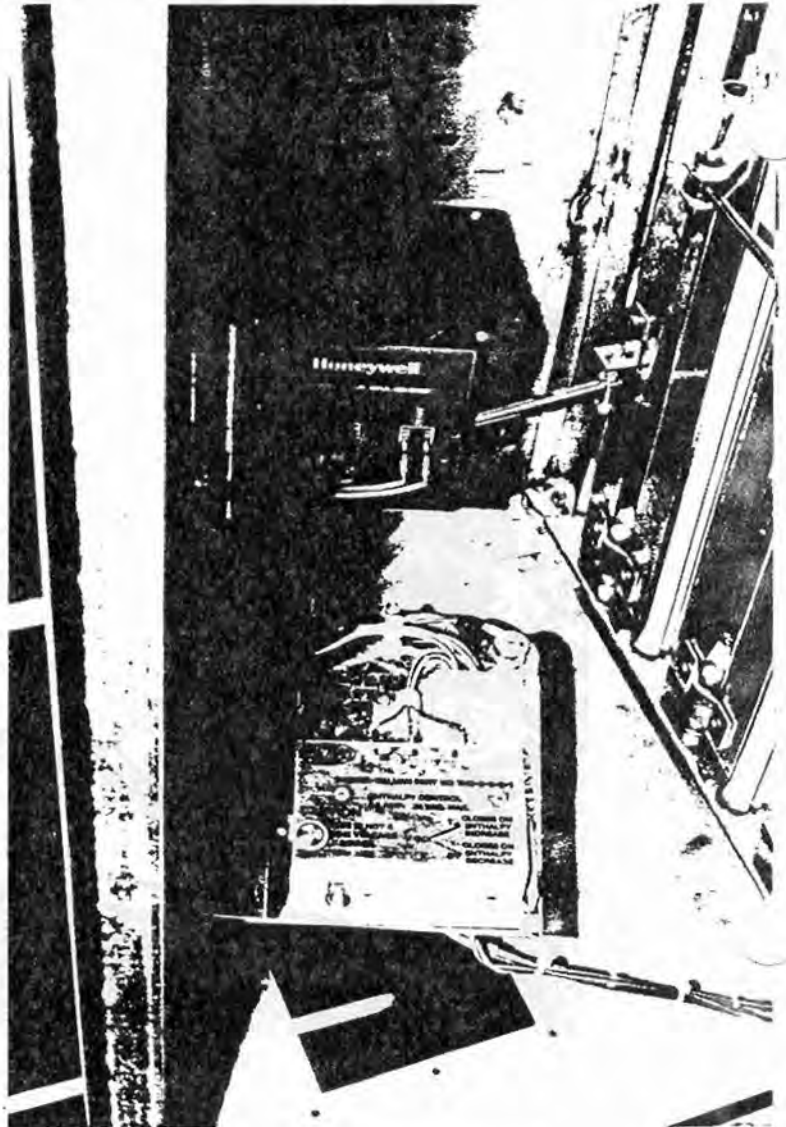

FIGURE 17

## RELIEF DAMPER

Many buildings have enough natural relief to avoid severe problems with building and over-pressurization. In some installations, where large quantities of outdoor air is brought into a tightly constructed building, exhaust provisions may be required to prevent over-pressurization. This can be accomplished by (a) "natural" relief, (b) barometric relief dampers or (c) exhaust dampers. The need must be determined and if required, the proper selection must be made for the application by the HVAC system designer. A fully integrated exhaust damper system is available as an extra cost option. (SEE SPECIFICATION SHEET.) Contact your dealer for details.

## CHECKOUT

When installation is complete, check the entire system for proper operation. The checkout procedure is intended to ensure:

1. The economizer controls operate properly.
2. The motor operates properly.
3. The dampers perform as intended without binding.

Set the enthalpy controller at maximum. Outdoor air damper should open and return air damper should close.

When the setting of the enthalpy controller is turned to the other end of its range, the outdoor air damper should close to minimum position and the return air damper should open.

Before leaving the installation, be sure to return all controllers to their recommended settings.

**PARTS LIST**  
**ECW-2, ECW-3, ECW-4**  
**ECONOMIZER**

3/85

Part No.	Description	ECW-2	ECW-3	ECW-4
8201-015	Relay	x	x	x
8201-013	Relay	x	x	x
8602-002	Enthalpy Control	x	x	x
8602-017	Economizer Motor	x	x	x
8602-018	Thermistor Sensor	x	x	x
8602-019	Minimum Position Potentiometer	x	x	x
7004-020	Filter 10x2501	x		
7004-021	Filter 16x25x1		x	
7004-022	Filter 16x34x1			x
7002-005	Moisture Eliminator 8-7/8x24½x1	x		
7002-006	Moisture Eliminator 12½x29x1		x	
7002-007	Moisture Eliminator 12½x32½x1			x