



## 6.00 PARAMETER LIST

#	MEANING	SETTING	FACTORY SETTING
dt	Delta T Set Point	Range (dt) 0.8 .. 50.1 °F	15 °F
dtD	Delta T hysteresis	Range 0.8 .. 17.9 (dt) °F	2 °F
OFS	Offset 1, temperature calibration for probe on the storage tank	Range -8.4 .. +7.6 °F	0 °F
OF2	Offset 2, temperature calibration for probe on the collector	Range -8.4 .. +7.6 °F	0 °F
AcY	Anticycling time relay	Range 0 .. 254 seconds	3 s
AF	Anti Freeze protection	Range 0.3 .. 50.0 °F; OFF: the protection is disabled.	oFF
OP	Over Temperature protection	Range 32.1 .. 228 °F; OFF: the protection is disabled.	159 °F
Opd	Over Temperature hysteresis	Range 0.8 .. 17.9 °F	5 °F
AdF	Anti Freeze hysteresis	Range 0.8 .. 17.9 °F	5 °F
unt	Temperature displayed unit	0: Celsius; 1: Fahrenheit	1
rES	Resolution	0: decimal point resolution; 1: unit resolution	1
utd	Display update time delay	Range 0 .. 60 sec	1 sec
Pt	Sensor Probe Type	0: NTC (10Kohm thermistor; range -40..+248°F) 1: PTC (1Kohm thermistor; range -58..+302°F)	0

## 7.00 ANOMALIES SIGNALING - ONLY IN AUTOMATIC MODE -

MSG	CAUSE	OUTPUT
Hit	The temperature of probe 1 (storage water tank) is higher than the OP value (over-temperature) .	- output K1 will switch-off.
PF1	The probe input line 1 is open or short circuited. The storage tank measured temperature is out of range.	- output K1 will switch-off.
PF2	The probe input line 2 is open or short circuited. The collector measured temperature is out of range.	- output K1 will switch-off.

Azel Technologies Inc. reserves the right to make changes without further notice to any products herein to improve reliability, function or design. Azel Technologies Inc. does not assume any responsibility for any improper use or application of any product or circuit described herein. Azel Technologies Inc. products are not designed, intended, or authorized to be used as components in systems or applications intended to support or sustain life, or for any other application in which the failure of the Azel Technologies Inc. product could create a situation where personal injury or death may occur.

## 8.00 SPECIFICATIONS

**DISPLAY:** 3 digit, 13.2 mm, high intensity green;

**INPUTS:** two NTC sensors or two PTC sensors;

**MEASURING RANGE:** -55 ... +302 °F for PTC probe;  
-39 ... +248 °F for NTC probe;

**ACCURACY AT 25°C:** ±1 °F + 1 digit;

**RESOLUTION:** 0.2 or 2 °F;

**OUTPUTS:** 1 spdt 250Vac 16A max resistive (1hp);

**POWER SUPPLY:** 115 Vac ±10% 50/60Hz;

### ENVIRONMENTAL CONDITIONS:

- operating temperature: -5 ... +50 °C;
- storage temperature: -20 ... +70 °C;
- relative humidity: 30 ... 90 % non condensing;
- no shocks or vibrations;

### MECHANICAL DATA:

- plastic housing self extinguishing type UL94V0;
- connections through terminal block for 2.5mm<sup>2</sup> gauge wire;
- protection degree: IP64 for the frontal panel (enclosure IP31).

**Typical terminal connections** (See the label close to the terminals for the right power supply diagram connection).

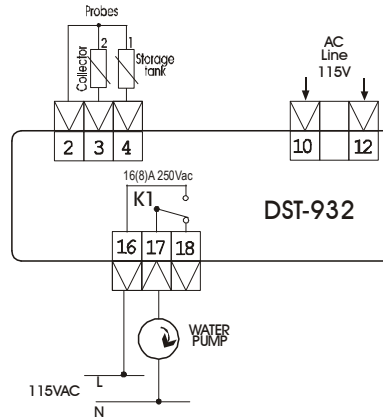

**Azel Technologies Inc.**  
PO BOX 53138  
10 Royal Orchard Blvd.  
THORNHILL, ONTARIO  
CANADA L3T 7R9  
Ph: 905-223-5567  
Fax: 905-223-3778  
web: [www.azeltec.com](http://www.azeltec.com)  
e-mail: [info@azeltec.com](mailto:info@azeltec.com)

## AZEL TECHNOLOGIES INC.

### Installation and operating instructions

## DST-932

### Differential Temperature Control for Solar Heating System

Rev.: 11-10-2005 Cod.: 00990270

### FRONTAL PANEL LAYOUT AND FUNCTIONS

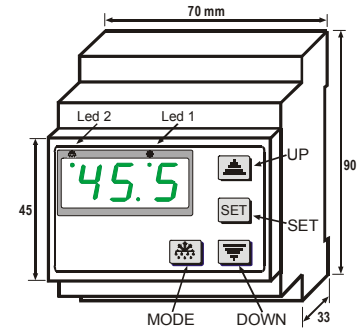

**Up:** 1) To increase the value of the selected parameter; 2) To scroll the parameters in SET mode; 3) To show the collector temperature (probe 2).

**Down:** 1) To decrease the value of the selected parameter; 2) To scroll the parameters in SET mode.

**Set:** To access the parameter menu to view and change the values. It is also the "Enter" key to confirm the new values.

**Mode:** Used to switch the automatic/manual mode.

## 1.00 GENERAL DESCRIPTION AND INSTALLATION NOTICE

The DST-932 model is conceived to control the Solar Heating Systems. The DST-932 drives a pump in order to warm up the water into a storage tank (by the sun energy). The controller reads the temperatures of the storage tank (T1) and of the collector (T2), when this differential temperature (T2-T1) is higher than a set value (dt) it will switch on the water pump. It is possible to limit the maximum temperature of the storage tank and also activate a freeze protection function. By switching to manual mode it allows the test of the heating system. The controller must be installed in a place protected from extreme vibration, impact, water, corrosive gases, and where temperatures and moisture do not exceed the maximum rating levels indicated in the specifications. The same directions are valid for the probe installation.

### 1.10 THE THERMOSTAT PROBES

The probes must be installed in a place to measure the correct average temperature of the system. The probe is not waterproof, it should be placed with its head upward, so that drops would not penetrate into the bulb and damage the sensor. Maintain the length of the electrical wires as short as possible in order to keep the noise picked by them at a low level, otherwise a shielded wire will be needed, where the shield will be connected to the ground. If moisture goes into the probe bulb, it will false the reading temperature and the control action.

### 1.20 ELECTRICAL WIRING

We recommend to protect the power supply of the controller from electrical noise, spikes, and especially from voltage surges and drops. This can be easily done following these recommendations:

- separate the power supply of the loads (boilers, heaters, fans, etc) from the power supply of the controller. This can alleviate problems related to voltage dips that can arise during the switch-on of the loads, that may interfere with the controller's microprocessor causing unexpected resets.
- the cables of the probes and the ones of the controller supply or the loads must be separated and not close, to reduce spikes and noise on the sensor. This improves the stability of the reading and it also makes the commutation of the device more accurate.

### 1.30 CRITICAL ENVIRONMENT

For applications in heavy industrial environment these rules should be followed.

- After having identified the source of noise spikes, it is recommended to apply a line filter to the source in question of the type specifically designed to solve EMC (Electromagnetic compatibility) related problems. Sometimes it may be sufficient an RC type filter, also called «snubber», connected in parallel to the external relay coils, or circuit breakers.
- An independent power supply should be used to power the device in extreme conditions.

### 1.40 MOUNTING

The controller is a DIN rail mounting instrument which can be mounted onto the wall or panels. For easy mounting, remove the DIN rail by sliding it out first. Use screws to mount the DIN rail onto the wall/panel. Then snap on the control to the DIN rail by pulling black trigger on the bottom with a screw driver.

## 2.00 HOW THE DEVICE WORKS (overview)

The DST-932 is a differential temperature controller. In automatic mode it drives the relay output checking the difference of the temperatures from the collector T2 and the storage tank T1. In order to store the solar energy, it switches on a circulator pump as soon as T2-T1 is greater than a Delta T set point (dt). Also, there are over temperature and freeze alarm.

To verify the whole heating system it is possible to toggle to manual mode and switching on or off the circulator pump. In manual mode the controller does not read any probe value, so no alarm function is activate.

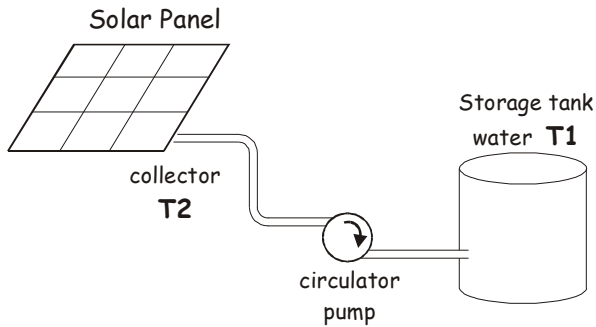

## 2.10 AUTOMATIC MODE CONTROL

The controller check every conditions in the following matter:

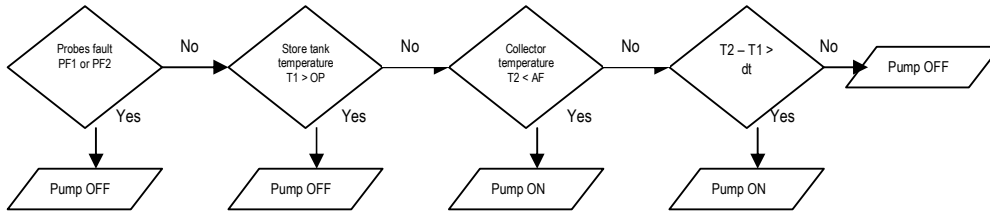

## 2.20 FAULT TOLERANCE (only in Automatic mode)

In case of probe failure the DST-932 controller display a message PF1 or PF2 and it switches off the output K1 (as per table 7.00).

## 3.00 DISPLAY FUNCTIONS

The display has three digits available, of the seven segment type.

During Automatic mode working it shows the value of the storage tank probe temperature T1. Pushing the upper button, it shows for 3 seconds the collector probe temperature T2. In an over-temperature alarm condition it blinks the "Hit" message (as described in the «anomalies signalling» table 7.00).

In manual mode the display shows the current selected mode: on or off. No one alarm or temperature is checked and showed.

The leds have the following functions: LED 1 lights on when the output K1 (water pump) is activated. The led 2 blinks during the setting operations.

## 4.00 HOW TO DISPLAY AND ADJUST THE "DELTA T" SET POINT

**Note:** The internal mathematic calculation of the thermostat works in °C. When adjusting the temperature with temperature display unit set as °F, it may increment/decrement by 2°F instead of 1°F. This is for conversion rounding off purpose, so not all the values of °F will be represented" - EXAMPLE: SET= 73, 75, 77, 78, 80, 82... (For rES = 1). If more accuracy is desired, decimal point resolution (rES=0) can be set. Then all the values of °F will be displayed and the increment/decrement is changed by 0.1/0.2 °F.

- 1) Press "SET" and hold it for 3s, "dt" is displayed;
- 2) Press "SET" to view the dt Set Point value, adjust it by using "▲" or "▼";
- 3) Press "SET" to confirm the data, after few seconds the controller will leave the set mode and the data will be stored in the memory.

**WARNING:** the instrument must not be reset before leaving the set mode, otherwise the new setting will be lost.

## 4.10 HOW TO ADJUST THE OPERATING PARAMETERS

- 1) Press "SET" and hold it for 10s, the code of the first variable "dtd" will appear;
- 2) Press "▲" or "▼" to scroll all the parameter codes;
- 3) While a code is displayed press "SET" to view its content, adjust it by pressing "▲" or "▼";
- 4) Press "SET" to confirm the data, after 10s the controller will leave the set mode and the data will be stored in the memory.

**WARNING:** the instrument must not be reset before leaving the set mode, otherwise the new setting will be lost.

**Note:** In every case the controller automatically interrupts any setting operation if any push-button isn't pressed for at least 10 seconds. The new values for time parameters will be active only after the start of the following time cycle.

## 4.20 HOW TO TOGGLE MANUAL-AUTOMATIC MODE

Press and hold for 5s the "MODE" key, the DST-932 will toggle among the following modes:

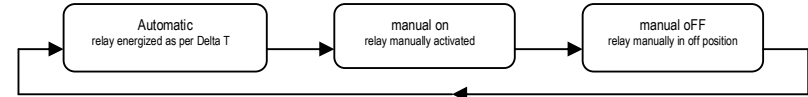

In automatic mode the controller shows the storage tank temperature and it controls the water pump as indicated on 2.10.

In manual mode the controller switches on (or off) the relay output and it shows "on" (or "off") on the display. It is suitable to test the solar heating system. No error-detection-routines are activated (no probe faults, no over temperature, no anti freeze).

**After every power down condition, the controller starts up in automatic mode.**

## 4.30 HOW TO SHOWS THE COLLECTOR TEMPERATURE PROBE 2 (only in Automatic mode)

Press "▲", the display will show the collector temperature for 3 seconds, then it come back to show the storage tank temperature T1.

## 4.40 KEYBOARD LOCKING

Press and hold "▼" + "SET" for 10s, in order to lock and unlock the keyboard

(pay attention to do not modify the dt set point value, press first "▼" and then "SET" immediately and keep pressed for 10 seconds).

Code displayed for one second: "Pof" – keyboard locked; "Pon" – keyboard unlocked.

When the keyboard is locked it is not possible change any parameters value (apart from the dt Set Point).

## 5.0 GENERAL PARAMETERS DESCRIPTION

**dt – Delta T Set Point:** it's the minimum differential temperature, between the collector and the storage tank, to switch on the water pump (relay K1). The controller switch on the output K1 when T2-T1>dt.

**dtd – Delta T hysteresis:** the value that controls the output relay K1, moving the value of the dt set point in such a way that the system does not oscillate.

The controller switch off the output K1 when T2-T1<dtd.

**OFS – temperature offset for storage tank:** it is the variation temperature added or subtracted to the temperature measured by the storage tank probe to compensate for any deviation from the real value.

**OF2 – temperature offset for collector:** it is the variation temperature added or subtracted to the temperature measured by the collector probe to compensate for any deviation from the real value.

**AcY – main anticycling delay time:** it is the minimum time between two successive output maneuvers (off – on cycle) for the relay K1: when the water pump is switched-off, the controller wait at least "AcY" seconds to switch on it again. It is also the delay for the first activation of the relay K1 at the start-up.

**AF – anti freeze protection:** it is the collector temperature T2 below it the controller will switch on the pump. Regardless of the temperature difference T2-T1, when T2<AF the circulation pump runs providing frost protection. (only in automatic mode)

**OP – over temperature protection:** it is the maximum temperature T1 of the storage tank, above it the controller will active the over heat alarm protection, switching off the pump and blinking "Hit" on the display. Regardless of the temperature difference T2-T1, when T1>OP the circulation pump stops. This function is priority to the other functions. (only in automatic mode)

**OPd – over temperature hysteresis:** the value that controls the ending of the over temperature alarm protection: when T1<OP-OPd the controller can switch on the output again, as per T2-T1 value.

**AdF – over temperature hysteresis:** the value that controls the ending of the anti freeze protection: when T2>AF+AdF the controller stops the pump and it can drive the output again as per T2-T1 value.

**unt - displayed unit:** it switches the temperature unit between Celsius and Fahrenheit (internal calculations are made in Celsius and then converted to Fahrenheit - see point 4.00 note).

**rES – resolution:** it allows to display the measured value with decimal or unitary resolution.

**utd – update Time delay:** it is the time delay that determines the display updating of the temperature (the min update time of the display is 5 sec.). The switching over of the relay is related only to the acy not to utd values.

**Pt – Sensor probe type:** choice of either 10K ohm NTC sensor or 1K ohm PTC sensor.