

# INSTALLATION INSTRUCTIONS BCE4MS SERIES AIR HANDLER

**MULTI-POSITION AIR HANDLER**  
507510-01  
3/2018

Litho U.S.A.

## Table of Contents

Upflow/Downflow Unit Dimensions .....	2
Horizontal Unit Dimensions .....	3
Shipping and Packing List .....	4
Model Number Identification .....	4
General .....	4
Installation Clearances .....	4
Requirements .....	5
Installing the Unit .....	5
Brazing Connections .....	9
Installing the Condensate Drain .....	11
Inspecting and Replacing Filters .....	12
Sealing the Unit .....	12
Field Control Wiring .....	13
Air Handler Control Button, Display and Jumpers ..	20
Target CFM Tables .....	25
Configuring Unit .....	29
Error Code Recall Mode .....	34
Indoor Blower Test .....	35
Operation .....	35
Cabinet Insulation .....	36
Homeowner Maintenance .....	36
Checkout Procedures .....	37

## NOTICE

A thermostat is not included and must be ordered separately.

- A Comfort Sync™ thermostat must be used in communicating applications.
- A non-communicating thermostat may be used in non-communicating applications.

In all cases, setup is critical to ensure proper system operation.

Field wiring for both communicating and non-communicating applications is illustrated in diagrams, which begin on page 13.

**THIS MANUAL MUST BE LEFT WITH THE HOMEOWNER FOR FUTURE REFERENCE**

**CHECK FOR AND REMOVE THE FOLLOWING ITEMS BEFORE OPERATING UNIT.**

**A** BLOWER HOUSING SUPPORT PAD.

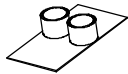

**B** HORIZONTAL DRAIN PAN (SEE UPFLOW APPLICATIONS ON PAGE 5 AND DOWNFLOW APPLICATIONS ON PAGE 8)

**C** REFRIGERANT LINE PLUGS (SEE BRAZING CONNECTION ON PAGE 9).

**FOR PROPER OPERATION THE ELECTRIC HEAT (IF APPLICABLE) MUST BE CONFIGURED (SET-UP) THROUGH THE AIR HANDLER CONTROL.**

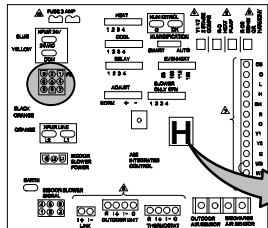

WHEN ELECTRIC HEAT IS INSTALLED, THE AIR HANDLER CONTROL MUST BE MANUALLY CONFIGURED. SEE JUMPERS AND LINKS GUIDE ON PAGE 19.

**CONFIGURE ELECTRIC HEAT**

**H** IF INSTALLED, ELECTRIC HEAT SECTIONS MUST BE CONFIGURED. SEE PROCEDURE IN FIGURE 22 ON PAGE 31.

**AEHK**

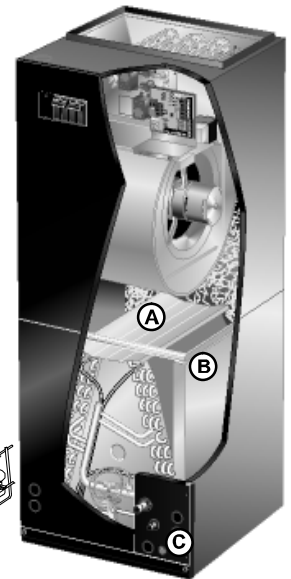

# Upflow and Downflow Unit Dimensions — Inches (mm)

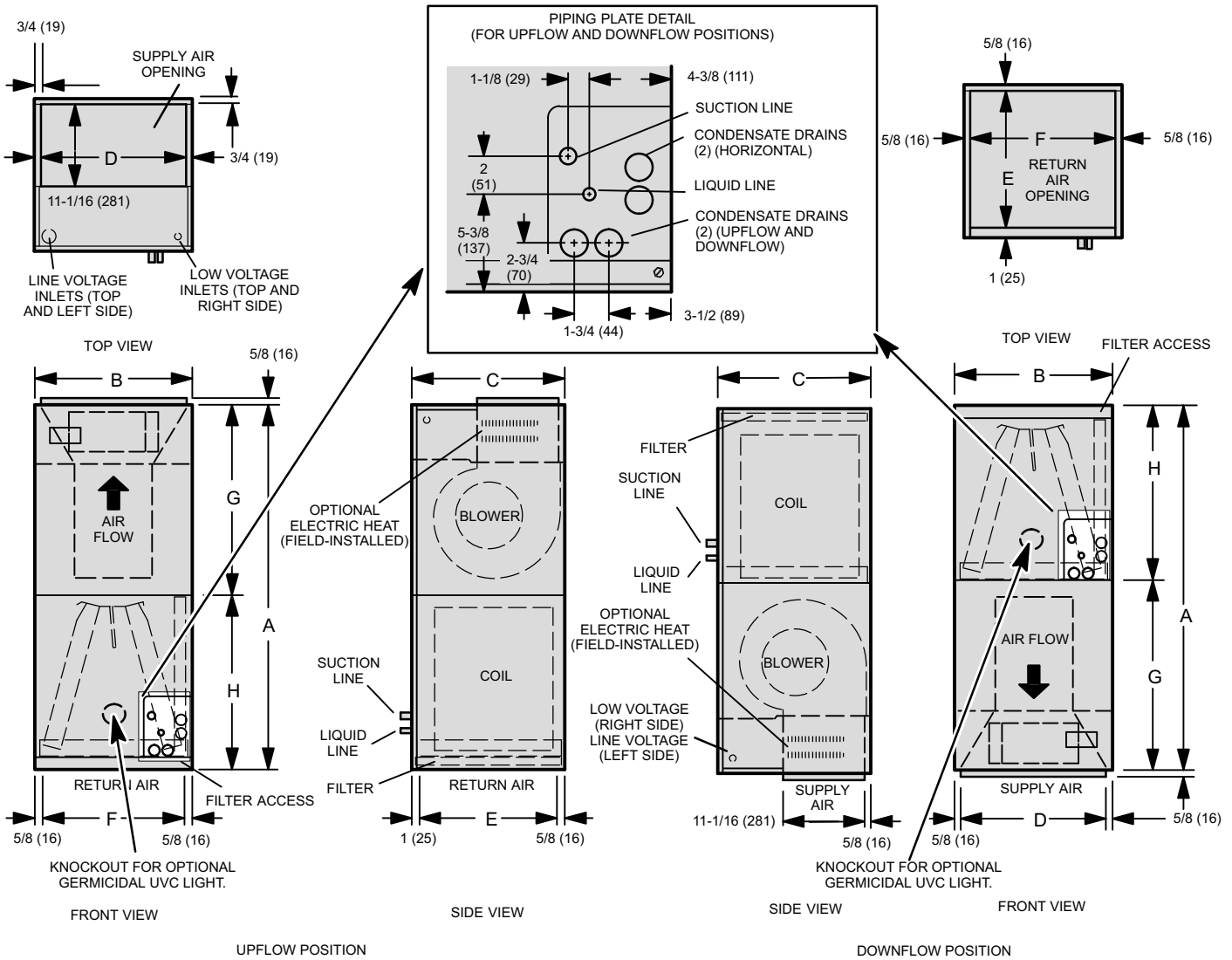

**Model Dimensions (Upflow, Downflow and Left- and Right-Hand Horizontal Applications)**

Model	24	30	36	48 and 60
Dim.	in. (mm)	in. (mm)	in. (mm)	in. (mm)
A	45-1/4 (1149)	49-1/4 (1251)	51 (1295)	58-1/2 (1486)
B	16-1/4 (413)	21-1/4 (540)	21-1/4 (540)	21-1/4 (540)
C	20-5/8 (524)	20-5/8 (524)	22-5/8 (575)	24-5/8 (625)
D	14-3/4 (375)	19-3/4 (502)	19-3/4 (502)	19-3/4 (502)
E	19 (483)	19 (483)	21 (533)	23 (584)
F	15 (381)	20 (508)	20 (508)	20 (508)
G	24-5/8 (625)	24-5/8 (625)	26-3/8 (670)	27-7/8 (708)
H	20-5/8 (524)	24-5/8 (625)	24-5/8 (625)	30-5/8 (778)

# Horizontal Left- and Right-Hand Unit Dimensions — Inches (mm)

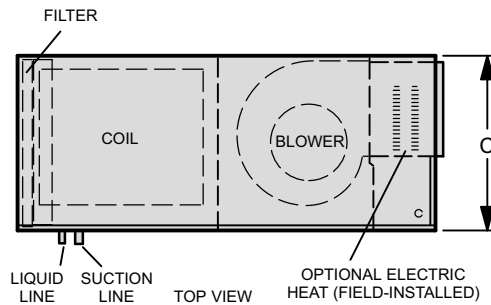
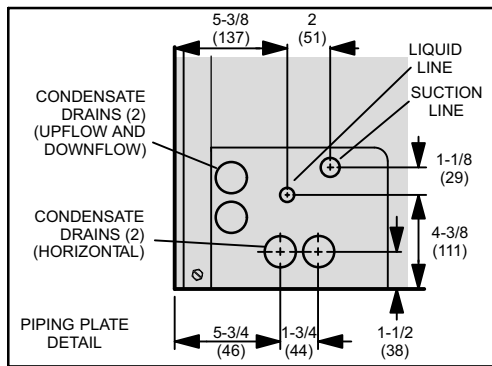

## Horizontal Position (Right-Hand Air Discharge)

FOR DIMENSIONS "A" THROUGH "H", SEE CHART ON PAGE 2.

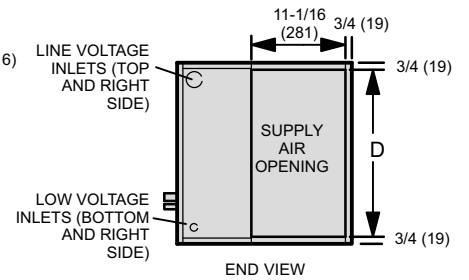
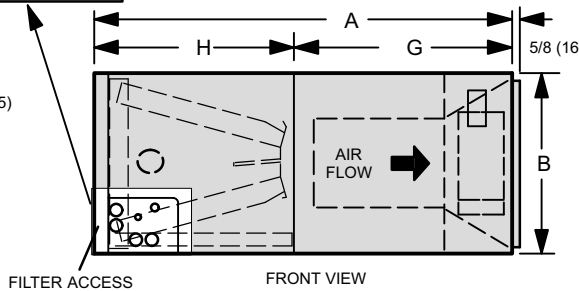
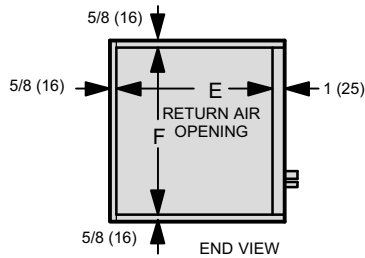

## Horizontal Position (Left-Hand Air Discharge)

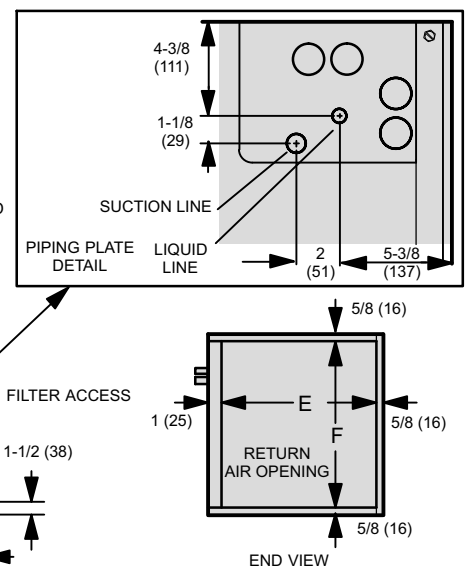
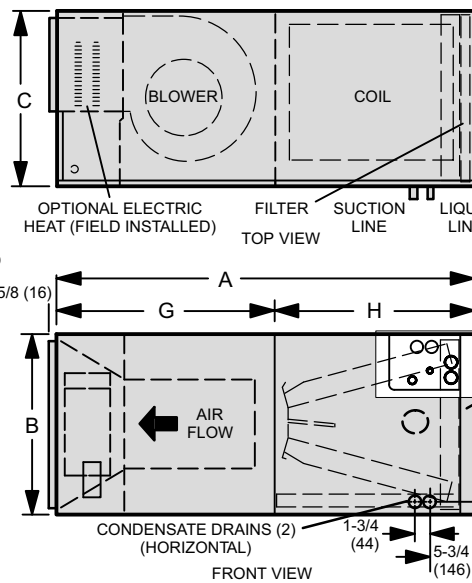
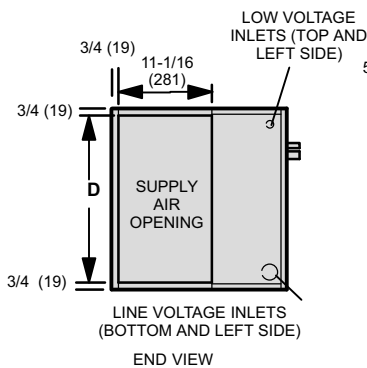

## Model Number Identification

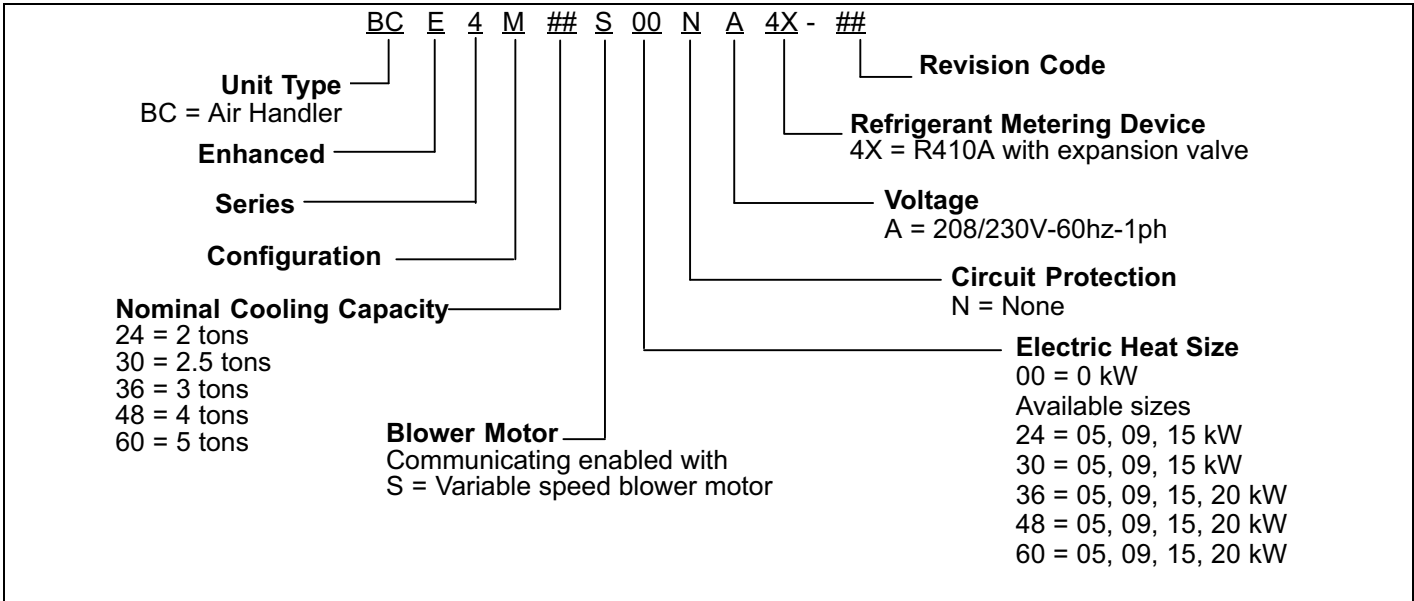

## Shipping and Packing List

Check unit for shipping damage. Consult last carrier immediately if damage is found.

Package 1 of 1 contains the following:

- 1 — Assembled air handler unit
- 2 — Downflow drip shields and foam tape (only required for downflow configuration)
- 1 — Pipe nipple (Sch 80, 3/4" I. D. x 5")
- 1 — Warranty card

## General

This indoor unit is designed for installation with optional field-installed electric heat and a matched outdoor unit that is charged with HFC-410A refrigerant. These units, designed for indoor installation in multiple positions, are completely assembled for upflow and horizontal right-hand discharge before being shipped from the factory.

All BCE4MS air handlers are equipped with a factory-installed, internally mounted check / expansion valve, which is suitable for use in HFC-410A applications.

This air handler is compatible with non-communicating thermostats and non-communicating outdoor units. In addition, this unit has the enhanced capability of communicating with the Comfort Sync™ thermostats and Comfort Sync™-enabled outdoor units using the RSBUS protocols.

*NOTE — For downflow or horizontal left-hand air discharge, certain field modifications are required.*

These instructions are intended as a general guide and do not supersede local or national codes in any way. Consult authorities having jurisdiction before installation. Check equipment for shipping damage; if found, immediately report damage to the last carrier.

## Installation Clearances

<b>Cabinet</b>	0 inch (0 mm)
<b>To Plenum</b>	1 inch (25 mm)
<b>To Outlet Duct within 3 feet (914 mm)</b>	1 inch (25 mm)
<b>Floor</b>	See Note #1
<b>Service / Maintenance</b>	See Note #2

<sup>1</sup> Units installed on combustible floors in the downflow position with electric heat require optional downflow additive base.

<sup>2</sup> Front service access - 24 inches (610mm) minimum.

*NOTE — If cabinet depth is more than 24 inches (610 mm), allow a minimum of the cabinet depth plus 2 inches (51 mm).*

## ⚠ IMPORTANT

The Clean Air Act of 1990 bans the intentional venting of refrigerant (CFCs, HCFCs and HFCs) as of July 1, 1992. Approved methods of recovery, recycling or reclaiming must be followed. Fines and/or incarceration may be levied for noncompliance.

## ⚠ WARNING

During blower operation, the ECM motor emits energy that may interfere with pacemaker operation. Interference is reduced by both the sheet metal cabinet and distance.

## ⚠ CAUTION

As with any mechanical equipment, contact with sharp sheet metal edges can result in personal injury. Take care while handling this equipment and wear gloves and protective clothing.

## **⚠ WARNING**

Improper installation, adjustment, alteration, service or maintenance can cause personal injury, loss of life, or damage to property.

Installation and service must be performed by a licensed professional installer (or equivalent) or a service agency.

## **⚠ WARNING**

Improper installation of the air handler can result in personal injury or death.

Do not allow external combustion products or other contaminants to enter the return air system or to be mixed with air that will be supplied to the living space. Use sheet metal screws and joint tape or duct mastic to seal return air system to air handler. In platform installations, the air handler should be sealed airtight to the return air plenum. A door must never be used as a portion of the return air duct system. The base must provide a stable support and an airtight seal to the air handler. Allow absolutely no sagging, cracks, gaps, etc.

For no reason should return and supply air duct systems ever be connected to or from other heating devices such as a fireplace or stove, etc. Fire, explosion, carbon monoxide poisoning, personal injury and/or property damage could result.

## **Requirements**

In addition to conforming to manufacturer's installation instructions and local municipal building codes, installation of air handler units (with or without optional electric heat), MUST conform with the following National Fire Protection Association (NFPA) standards:

- NFPA No. 90A — Standard for Installation of Air Conditioning and Ventilation Systems
- NFPA No. 90B — Standard for Installation of Residence Type Warm Air Heating and Air Conditioning Systems

This unit is approved for installation clearance to combustible material as stated on the unit rating plate. Accessibility and service clearances must take precedence over combustible material clearances.

## **Installing the Unit**

BCE4MS units are factory-configured for upflow and horizontal right-hand discharge installation. For downflow or horizontal left-hand discharge, certain field modifications are required.

### **DISASSEMBLE AND REASSEMBLE AIR HANDLER UNIT**

This unit consists of two sections which are shipped assembled from the factory. If necessary, the unit may be disassembled to facilitate setting the unit. Follow the steps below:

#### **To disassemble:**

1. Remove access panels.

2. Remove both blower and coil assemblies. This will lighten the cabinet for lifting.
3. Remove one screw from the left and right posts inside the unit. Remove one screw from each side on the back of the unit. Unit sections will now separate.

#### **To reassemble:**

1. Align cabinet sections together.
2. Reinstall screws.
3. Replace blower and coil assemblies.
4. Replace access panel.

### **UPFLOW APPLICATION**

Use the following procedures to configure the unit for upflow operations:

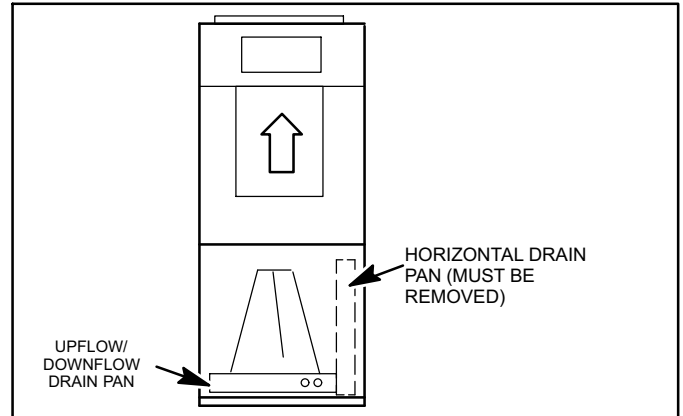

**Figure 1. Upflow Configuration**

1. The horizontal drain pan must be removed when the coil blower is installed in the upflow position. Removing horizontal drain pan will allow proper airflow and increase efficiency.
2. After removing horizontal drain pan, place the unit in desired location. Set unit so that it is level. Connect return and supply air plenums as required using sheet metal screws as illustrated in figure 1.
3. Install units that have no return air plenum on a stand that is at least 14" from the floor to allow for proper air return. Optional upflow unit stands are listed in table 1.

**Table 1. Optional Unit Side Stand (Upflow Only)**

<b>Models</b>	<b>Kit Numbers</b>
24	45K31
30, 36, 48 and 60	45K32

### **HORIZONTAL RIGHT — HAND DISCHARGE APPLICATION**

**NOTE** — When air handler is located above a finished space, the secondary drain pan must have a larger footprint than the air handler. In addition, a 3/4" (19.1MM) overflow drain line must be:

- Connected to secondary drain pan  
or
- Connected to the overflow drain outlet of the air handler drain pan.

Use the following procedures to configure the unit for horizontal right-hand discharge operations:

**NOTE** — For horizontal applications, a secondary drain pan is recommended. Refer to local codes.

1. No further adjustment is necessary. Set unit so that it is sloped 1/4 inch (6.35mm) towards the drain pan end of the unit.

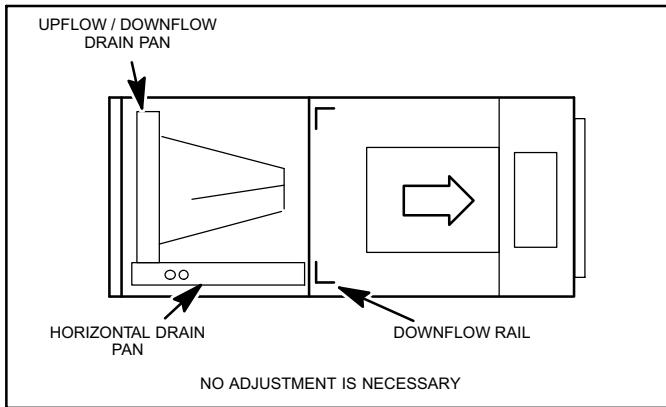

**Figure 2. Right-Hand Discharge Configuration**

2. If the unit is suspended, the entire length of the cabinet must be supported. If you use a chain or strap, use a piece of angle iron or sheet metal attached to the unit (either above or below) to support the length of the cabinet. Use securing screws no longer than 1/2 inch (12.7mm) to avoid damaging the coil or filter as illustrated in figure 3. Use sheet metal screws to connect the return and supply air plenums as required.

**HORIZONTAL RIGHT-HAND DISCHARGE APPLICATION IN HIGH HUMIDITY AREAS**

For horizontal applications in high humidity areas remove the downflow rail closest to the drain pan.

**To remove rail:**

1. Remove the screws from the rail at the back of unit and at the cabinet support rail.

2. Remove the downflow rail then replace screws.
3. Seal around the exiting drain pipe, liquid line, and suction line to prevent humid air from infiltrating into the unit.

**⚠ IMPORTANT**

When removing the coil, there is possible danger of equipment damage and personal injury. Be careful when removing the coil assembly from a unit installed in right- or left-hand applications. The coil may tip into the drain pan once it is clear of the cabinet. Support the coil when removing it.

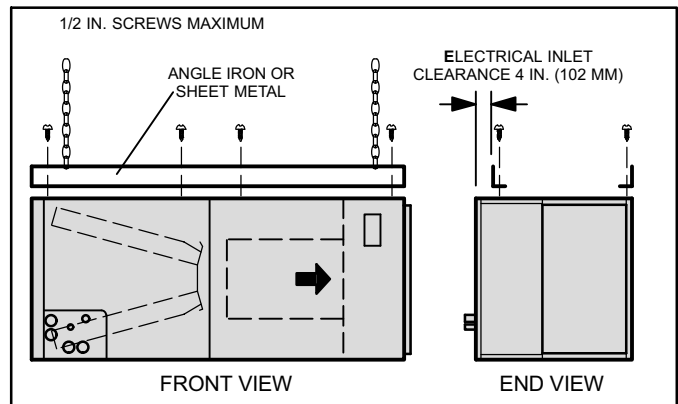
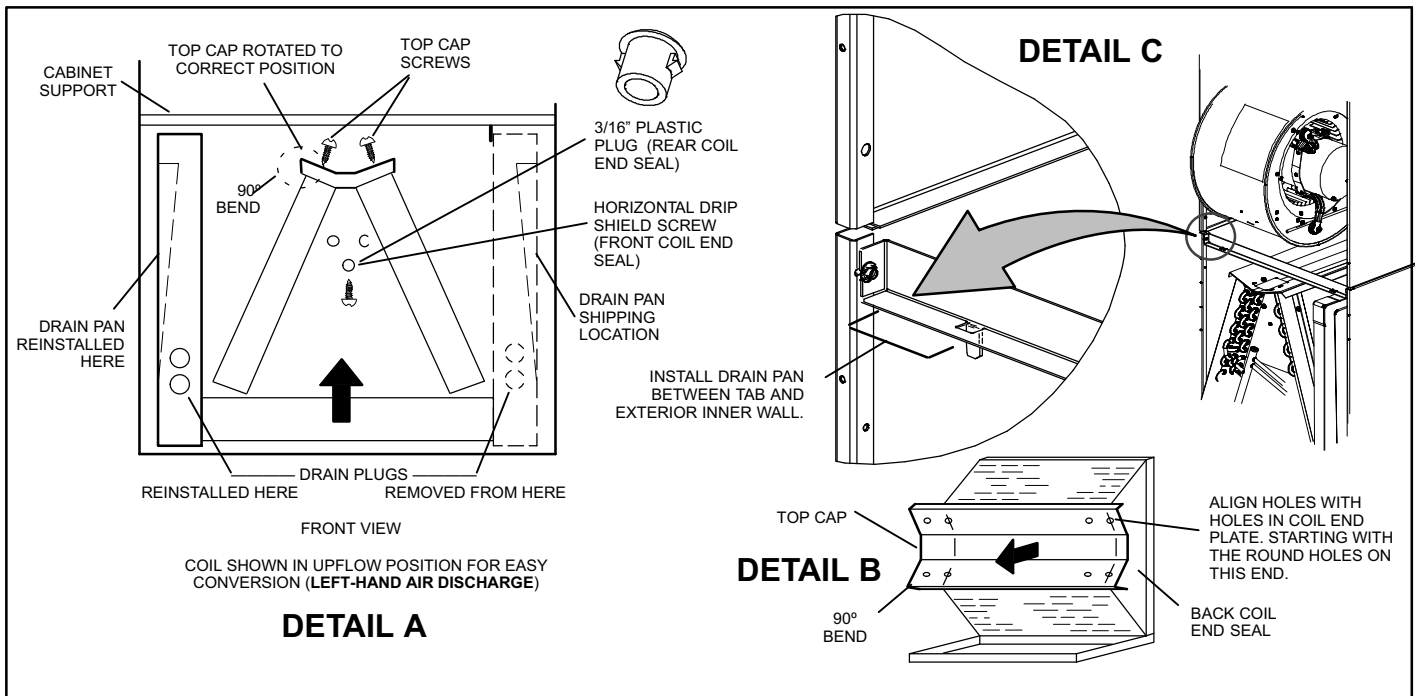

**Figure 3. Suspending Horizontal Unit**

**HORIZONTAL LEFT-HAND DISCHARGE APPLICATION**

Use the following procedures to configure the unit for horizontal left-hand discharge operations:

**NOTE** — For horizontal applications, a secondary drain pan is recommended. Refer to local codes.



**Figure 4. Field Modification for Left-Hand Discharge**

**▲ IMPORTANT**

After removal of drain pan plug(s), check drain hole(s) to verify that drain opening is fully open and free of any debris. Also check to make sure that no debris has fallen into the drain pan during installation that may plug up the drain opening.

1. Pull the coil assembly from unit. Pull off the horizontal drain pan.
2. Remove the drain plugs from back drain holes on horizontal drain pan and reinstall them on front holes.
3. Rotate drain pan 180° front-to-back and install it on the opposite side of the coil.
4. Remove screws from top cap as illustrated in figure 4, detail A.
5. Remove horizontal drip shield screw located in the center of the rear coil end seal as illustrated in figure 4, detail A.
6. Rotate horizontal drip shield 180° front to back.
7. Remove plastic plug from hole located on the center of front coil end seal and reinstall plug in center hole on rear coil end seal.
8. Reinstall horizontal drip shield screw in front coil end seal. Drip shield should drain downward into horizontal drain pan inside coil.

9. Rotate top cap 180° front-to-back and align with unused screw holes. Holes must align with front and back coil end plates. The top cap has a 45° bend on one side and a 90° bend on the other. The 90° bend must be on the same side as the horizontal drain pan as illustrated in figure 4, detail B.

*NOTE — Be very careful when you reinstall the screws into coil end plate engaging holes. Misaligned screws may damage the coil.*

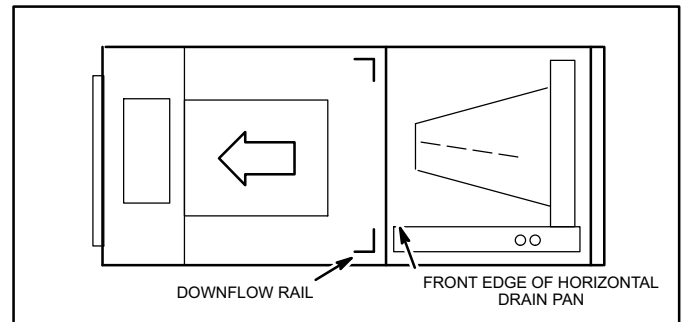

**Figure 5. Left-Hand Discharge Configuration**

10. From the upflow position, flip cabinet 90° to the left and set into place. Replace coil assembly. Replace coil assembly. Install drain pan between exterior inner wall and tab as illustrated in figure 4, detail C.

**NOTE** — For horizontal applications in high humidity areas, remove the downflow rail closest to the drain pan. To remove rail, remove screw from rail at back of unit and at cabinet support rail. Remove downflow rail then replace screws. Also, seal around the exiting drain pipe, liquid and suction lines to prevent infiltration of humid air.

11. Knock out drain seal plate from access door. Secure plate to cabinet front flange with screw provided.
12. Flip access door and reinstall it on the unit.
13. Set unit so that it is sloped 1/4 inch (6.35mm) toward the drain pan end of the unit. Connect return and supply air plenums as required using sheet metal screws.
14. If suspending the unit, it must be supported along the entire length of the cabinet. If using chain or strap, use a piece of angle iron or sheet metal attached to the unit (either above or below) so that the full length of the cabinet is supported. Use securing screws no longer than 1/2 inch (12.7mm) to avoid damage to coil or filter as illustrated in figure 3 on page 6. Connect return and supply air plenums as required using sheet metal screws.

### DOWNFLOW APPLICATION

Use the following procedures to configure the unit for downflow operations:

<b>⚠ CAUTION</b>
<b>If electric heat section with circuit breakers is applied to downflow BCE4MS unit, the circuit breakers must be rotated 180° to the UP position. See electric heat section installation instructions for more details.</b>

Table 2 outlines the sizes of the various drip shields.

**NOTE** — Discard the corrugated padding and the downflow drip shields from the foam pads on top of the unit. (The shields are used for downflow applications only.)

1. Remove the coil assembly from the unit.
2. For best efficiency and air flow, remove the horizontal drain pan from the units in downflow positions as illustrated in figure 6 on page 8.
3. Rotate cabinet 180° from the upright position. See figure 6. You may need to first remove the blower assembly to lighten the cabinet for lifting.
4. The provided foam tape creates a seal between the drip shield and the coil so that water does not leak into the air stream. The foam tape pieces are precut. Apply the tape to the drip shields as illustrated in figure 7 and specified as follows:
  - Apply foam tape down both ends of each shield. The tape should measure 4-3/4" X 2" (120 X 25 mm). Ensure that the tape covers both sides of the shield equally.
  - Apply the longer piece of 1-inch wide foam tape at the bottom of each shield between the end pieces of tape. See figure 7.
5. Install the downflow drip shield at the base of the coil as illustrated in figure 8.

**Table 2. Downflow Drip Shields (Tape Required)**

Units	Length	Width
24	Not Required	Not Required
30	15-7/8"	4-11/16"
36	17-7/8"	4-11/16"
48 and 60	19-7/8"	4-11/16"

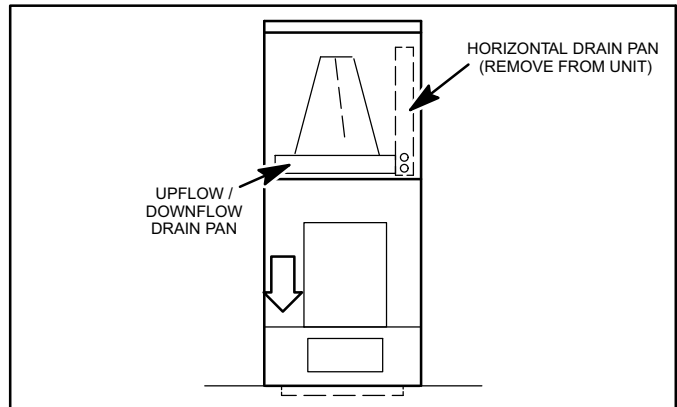

**Figure 6. Downflow Discharge Position**

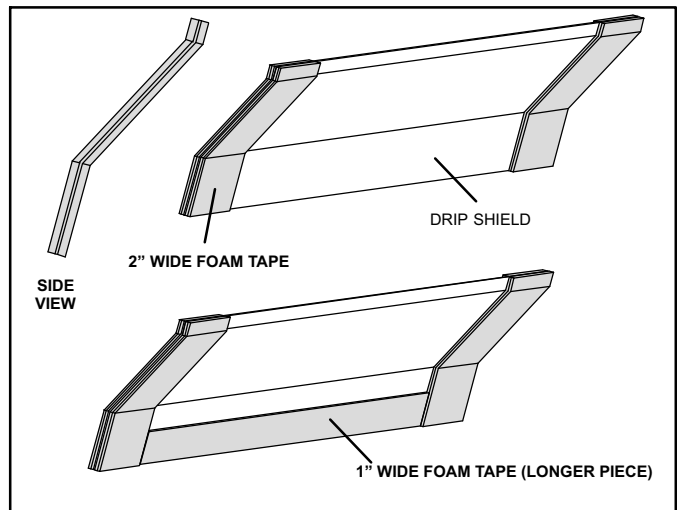

**Figure 7. Applying Foam Tape to Drip Shield**

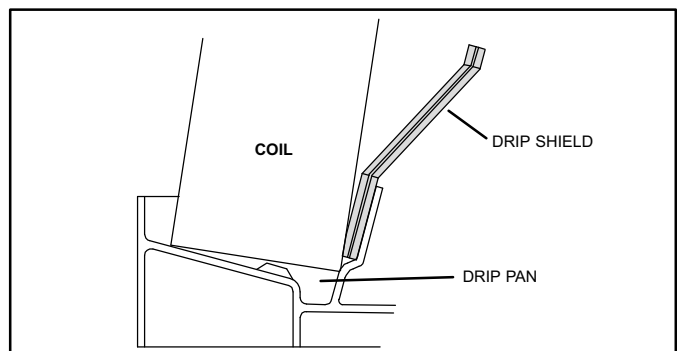
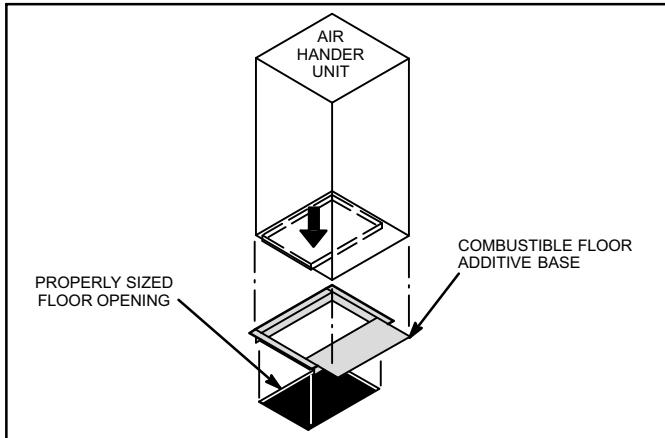

**Figure 8. Downflow Drip Shields**

6. Replace the coil assembly and blower if you have removed it. Replace the coil access panel.
7. Set the unit so that it is level. Using sheet metal screws, connect the return and supply air plenums as required.



**NOTE - For downflow application, metal or class I supply and return air plenums must be used.**



**Figure 9. Downflow Combustible Flooring Base**

8. For downflow installation on combustable flooring, an additive base must be used as illustrated in figure 9 on page 9. Downflow combustable flooring base kit 34J72 is available for use with the BCE4M24S. Base kit 44K15 is available for the BCE4M30S, 36S, 48S and 60S units.
9. Cut an appropriately sized opening for combustable base. Base dimensions are illustrated in figure 10. After opening has been cut, set the additive base into opening. Connect outlet air plenum to the additive base. Set the unit on the additive base so flanges of the unit drop into the base opening and seal against the insulation strips. The unit is now locked in place. Install return air plenum and secure with sheet metal screws.

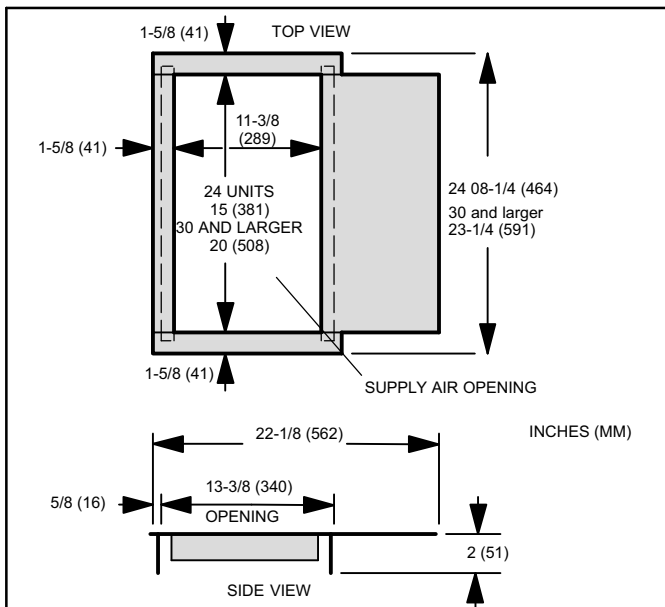

**Figure 10. Downflow Combustible Base Dimensions**

## Brazing Connections

### ! WARNING

Polyol ester (POE) oils used with HFC-410A refrigerant absorb moisture very quickly. It is very important that the refrigerant system be kept closed as much as possible. **DO NOT** remove line set caps or service valve stub caps until you are ready to make connections.

### ! WARNING



Danger of fire. Bleeding the refrigerant charge from only the high side may result in the low side shell and suction tubing being pressurized. Application of a brazing torch while pressurized may result in ignition of the refrigerant and oil mixture - check the high and low pressures before unbrazing.

### ! WARNING



When using a high pressure gas such as dry nitrogen to pressurize a refrigeration or air conditioning system, use a regulator that can control the pressure down to 1 or 2 psig (6.9 to 13.8 kPa).

### ! CAUTION

Brazing alloys and flux contain materials which are hazardous to your health.

Avoid breathing vapors or fumes from brazing operations. Perform operations only in well ventilated areas.

Wear gloves and protective goggles or face shield to protect against burns.

Wash hands with soap and water after handling brazing alloys and flux.

### ! IMPORTANT

To prevent the build up of high levels of nitrogen when purging, be sure it is done in a well ventilated area. Purge low pressure nitrogen (1 to 2 psig) through the refrigerant piping during brazing. This will help to prevent oxidation and the introduction of moisture into a system.

PLEASE READ IMPORTANT ISSUES CONCERNING BRAZING OPERATIONS ON PAGE 10 BEFORE PROCEEDING.

**C** USE A WET RAG TO PROTECT CTXV SENSING BULB WHEN BRAZING SUCTION LINE CONNECTIONS.

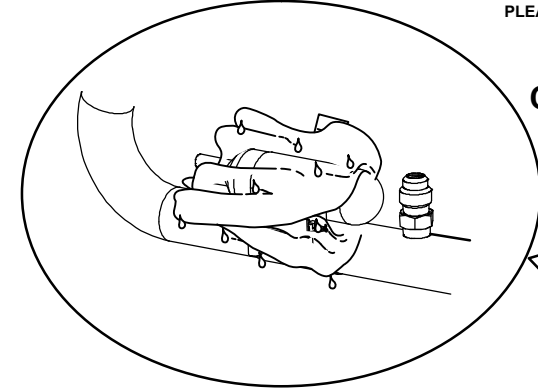

NOTE — Refer to outdoor unit installation instructions for refrigerant piping size requirements.

NOTE — Use silver alloy brazing rods with five or six percent minimum silver alloy for copper-to-copper brazing, 45 percent alloy for copper-to-brass and copper-to-steel brazing.

**A** REMOVE ACCESS PANEL

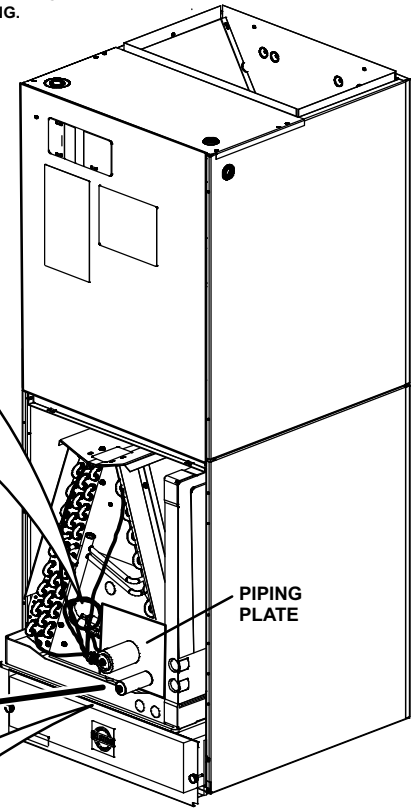
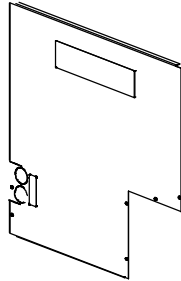

**B** REMOVE RUBBER PLUG FROM BOTH LIQUID AND SUCTION LINES

NOTE — BCE4MS SERIES UNITS USE NITROGEN OR DRY AIR AS A HOLDING CHARGE. IF THERE IS NO PRESSURE WHEN THE RUBBER PLUGS ARE REMOVED, CHECK THE COIL FOR LEAKS BEFORE INSTALLING.

**D** EITHER REMOVE PIPE WRAPPING OR PUSH WRAPPING BACK THROUGH HOLE IN PIPING PLATE BEFORE CONNECTING AND BRAZING LINE SET.

**F** CONNECT GAUGES AND START NITROGEN FLOW

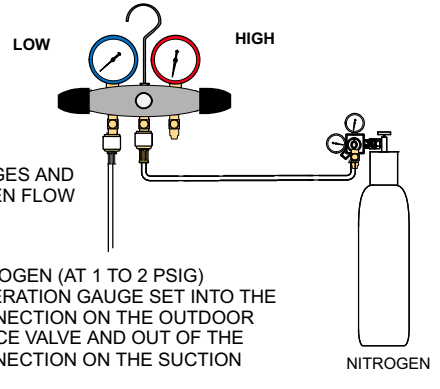

FLOW REGULATED NITROGEN (AT 1 TO 2 PSIG) THROUGH THE REFRIGERATION GAUGE SET INTO THE VALVE STEM PORT CONNECTION ON THE OUTDOOR UNIT LIQUID LINE SERVICE VALVE AND OUT OF THE VALVE STEM PORT CONNECTION ON THE SUCTION SERVICE VALVE.

**E** CONNECT PIPES

NOTE — REFRIGERANT LINE SETS SHOULD BE ROUTED TO ALLOW FILTER ACCESSIBILITY.

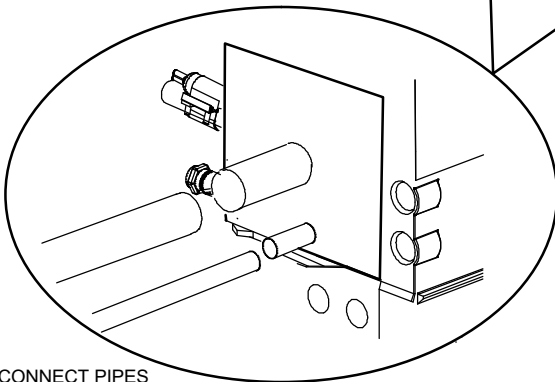

**G** PLACE A WET RAG AGAINST PIPING PLATE AND AROUND THE SUCTION LINE CONNECTION.

**H** BRAZE CONNECTION. ALLOW PIPE TO COOL BEFORE REMOVING WET RAG FROM CTXV SENSING BULB AND PIPING PANEL AREA.

**I** REPEAT PREVIOUS PROCEDURE FOR LIQUID LINE.

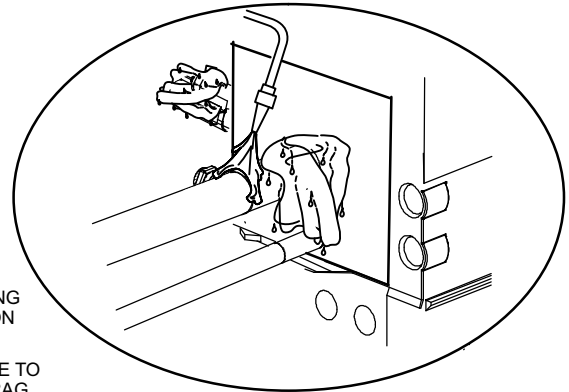

REFER TO INSTRUCTIONS PROVIDED WITH OUTDOOR UNIT FOR LEAK TESTING, EVACUATING AND CHARGING PROCEDURES

Figure 11. Brazing Connections

**Table 3. BCE4MS Refrigerant Connections and Line Set Requirements**

Models	Liquid Line	Vapor / Suction Line	L15 Line Set
24	3/8" (10mm)	5/8" (16mm)	L15 line set sizes are dependent on unit matchups.
30 and 36	3/8" (10mm)	3/4" (19mm)	
48	3/8" (10mm)	7/8" (22mm)	
60	3/8" (10mm)	7/8" (22mm)	Field-fabricated
NOTE — Some applications may require a field-provided 7/8" to 1-1/8" adapter.			

## ⚠ IMPORTANT

Refrigerant lines must be connected by a qualified technician in accordance with established procedures.

Refrigerant lines must be clean, dehydrated, refrigerant-grade copper lines. Air handler coils should be installed only with specified line sizes for approved system combinations.

Handle refrigerant lines gently during installation. Sharp bends or kinking in the lines will cause a restriction.

Do not remove sealing caps from the refrigerant piping or unit connection points until connections are ready to be completed.

### Installing the Condensate Drain

## ⚠ IMPORTANT

After removal of drain pan plug(s), check drain hole(s) to verify that drain opening is fully open and free of any debris. Also check to make sure that no debris has fallen into the drain pan during installation that may plug up the drain opening.

### MAIN DRAIN

Connect the main drain and route downward to drain line or sump. Do not connect drain to a closed waste system. See Figure 13 for typical drain trap configuration.

### OVERFLOW DRAIN

It is recommended that the overflow drain is connected to a overflow drain line for all units. If overflow drain is not connected, it must be plugged with provided cap.

For downflow orientation, the overflow drain **MUST** be connected and routed to a overflow drain line. See Figure 12 for main and overflow drain locations based on coil orientation.

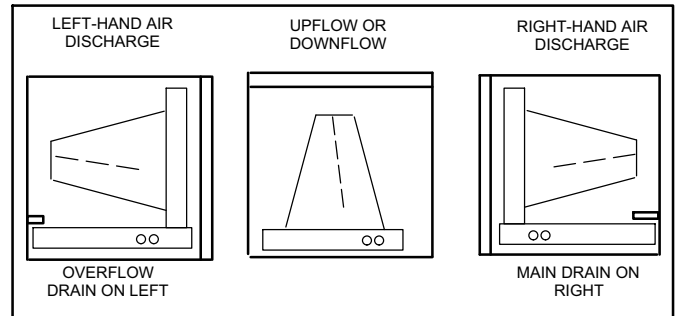

**Figure 12. Main and Overflow Drain Locations based on Coil Orientation**

### BEST PRACTICES

The following best practices are recommended to ensure better condensate removal:

- Main and overflow drain lines should **NOT** be smaller than both drain connections at drain pan.
- Overflow drain line should run to an area where homeowner will notice drainage.
- It is recommended that the overflow drain line be vented and a trap installed. Refer to local codes.

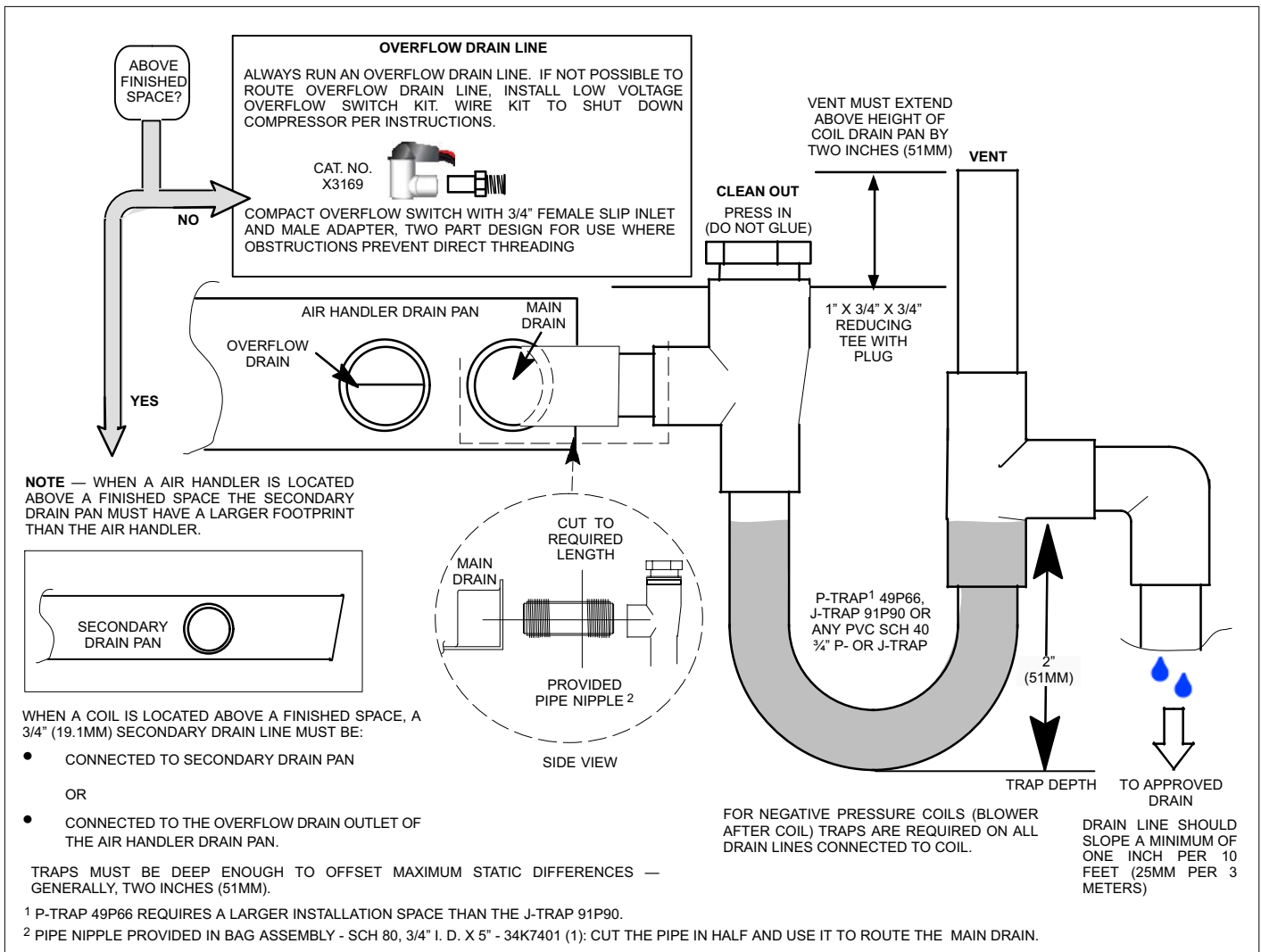

Figure 13. Typical Main and Overflow Drain Installations

**Inspecting and Replacing Filters**

**⚠ IMPORTANT**

Filter access door must be in place during unit operation. Excessive warm air entering the unit from unconditioned space may result in water blow-off problems.

Filters may be duct-mounted or installed in the cabinet. A filter is installed at the factory. Note that filter access door fits over access panel. Air will leak if the access panel is placed over the filter door.

Filters should be inspected monthly and must be cleaned or replaced when dirty to assure proper furnace operation.

**To replace filter:**

- Loosen the thumbscrews holding the filter panel in place.
- Slide the filter out of the rails on either side of cabinet.
- Remove dirty filter. Insert new filter.
- Replace panel.

See table 4 for replacement filter sizes.

Table 4. Filter Dimensions

Unit Model No.	Filter Size Inches (mm)
24	15 X 20 x 1(381 x 508 x 25)
30	20 x 20 x 1(508 x 508 x 25)
36	20 x 20 x 1(508 x 508 x 25)
48 and 60	20 x 24 x 1(508 x 610 x 25)

**Sealing the Unit**

**⚠ WARNING**

There must be an airtight seal between the bottom of the air handler and the return air plenum. Use fiberglass sealing strips, caulking, or equivalent sealing method between the plenum and the air handler cabinet to ensure a tight seal. Return air must not be drawn from a room where this air handler or any gas-fueled appliance (i.e., water heater), or carbon monoxide-producing device (i.e., wood fireplace) is installed.

Seal the unit so that warm air is not allowed into the cabinet. Warm air introduces moisture, which results in water blow-off problems. This is especially important when the unit is installed in an unconditioned area.

Make sure the liquid line and suction line entry points are sealed with either the provided flexible elastomeric thermal insulation, or field provided material (e.g. *Armaflex*, *Permagum* or equivalent). Any of the previously mentioned materials may be used to seal around the main and auxiliary drains, and around open areas of electrical inlets.

**Field Control Wiring**

**⚠ WARNING**

Electric Shock Hazard.

Can cause injury or death.

Foil-faced insulation has conductive characteristics similar to metal. Be sure there are no electrical connections within a 1/2" of the insulation. If the foil-faced insulation comes in contact with electrical voltage, the foil could provide a path for current to pass through to the outer metal cabinet. While the current produced may not be enough to trip existing electrical safety devices (e.g. fuses or circuit breakers), the current can be enough to cause an electric shock hazard that could cause personal injury or death.

Wiring must conform to the current National Electric Code ANSI/NFPA No. 70, or Canadian Electric Code Part I, CSA Standard C22.1, and local building codes. Refer to following wiring diagrams. See unit nameplate for minimum circuit ampacity and maximum over-current protection size.

**⚠ WARNING**

Run 24V Class II wiring only through specified low voltage opening. Run line voltage wiring only through specified high voltage opening. Do not route high and low voltage wiring through a single opening.

Select the proper supply circuit conductors in accordance with tables 310-16 and 310-17 in the National Electric Code, ANSI/NFPA No. 70 or tables 1 through 4 in the Canadian Electric Code, Part I, CSA Standard C22.1.

Separate openings have been provided for 24V low voltage and line voltage. Refer to the dimension illustration of specific location.

**⚠ CAUTION**

**USE COPPER CONDUCTORS ONLY.**

**WIRING CONNECTIONS**

1. Install line voltage power supply to unit from a proper circuit breaker. Confirm line voltage. Check that correct transformer line tap is connected (208 or 240V).
2. Ground unit at unit disconnect switch or to an earth ground.

*NOTE — Connect conduit to the unit using the correct conduit fitting. Units are approved for use only with copper conductors. A complete unit wiring diagram is located on the unit blower housing.*

3. Install low voltage wiring from outdoor to indoor unit and from thermostat to indoor unit.

*NOTE — For proper voltages, select control wiring gauge per the charts on page 17.*

KEY	DESCRIPTION
A92	CONTROL- INTEGRATED
B3	MOTOR-BLOWER
J48	JACK-MOTOR, VARIABLE SPEED
J49	JACK-MOTOR, VARIABLE SPEED
P8	PLUG-ELECTRIC HEAT
P48	PLUG-MOTOR, VARIABLE SPEED
P49	PLUG-MOTOR, VARIABLE SPEED
T1	TRANSFORMER-CONTROL

BLOWER COIL	RECOMMENDED BLOWER SPEED TAP SELECTION			
	SPEED TAP SELECTION			
	COOL		HEAT	
	CONDENSING UNIT	HEAT PUMP	CONDENSING UNIT WITH ELECTRIC HEAT ONLY	HEAT PUMP WITH ELECTRIC HEAT
-024 -030 -036	COOL PIN #3	COOL PIN #3	HEAT PIN #4	HEAT PIN #4
-048	COOL PIN #2	COOL PIN #2	HEAT PIN #1	HEAT PIN #1
-060	COOL PIN #3	COOL PIN #3	HEAT PIN #1	HEAT PIN #1

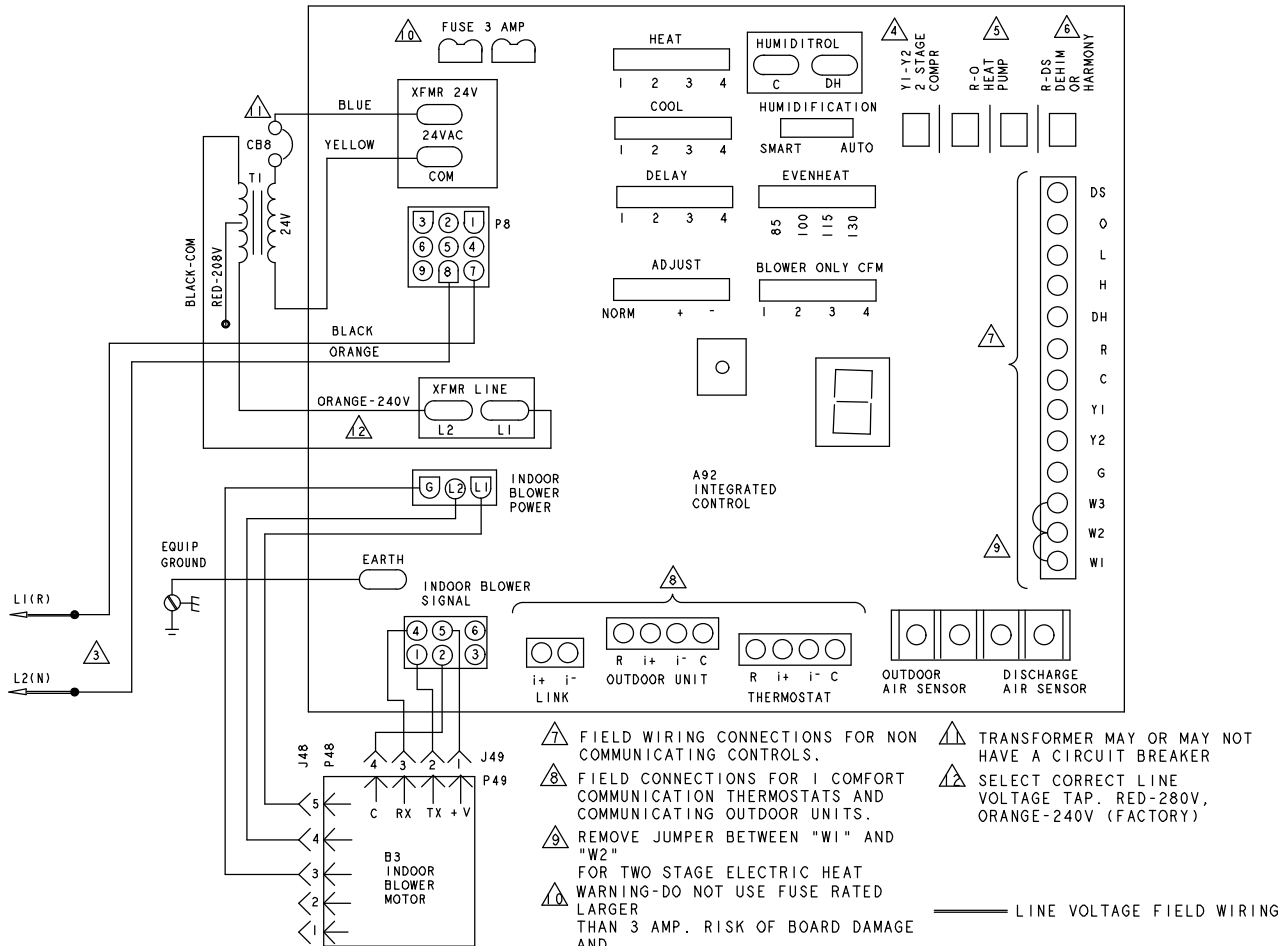

- ⚠ REFER TO FACTORY BLOWER SPEED TAP SELECTION CHART ON UNIT FOR BLOWER SPEED INFORMATION.
- ⚠ NEC/CEC CLASS 2 3VA
- ⚠ USE COPPER CONDUCTORS ONLY. REFER TO UNIT RATING PLATE FOR MINIMUM CIRCUIT AMPACITY AND MAXIMUM OVERCURRENT PROTECTION SIZE
- ⚠ CLIP LINK "Y1" TO "Y2" FOR TWO STAGE UNIT
- ⚠ CLIP LINK "R" TO "O" WHEN HEAT PUMP IS USED
- ⚠ CLIP LINK BETWEEN "R" AND "DS" WHEN DEHUMIDIFICATION CONTROL IS USED

- ⚠ FIELD WIRING CONNECTIONS FOR NON COMMUNICATING CONTROLS.
- ⚠ FIELD CONNECTIONS FOR I COMFORT COMMUNICATION THERMOSTATS AND COMMUNICATING OUTDOOR UNITS.
- ⚠ REMOVE JUMPER BETWEEN "W1" AND "W2" FOR TWO STAGE ELECTRIC HEAT WARNING-DO NOT USE FUSE RATED LARGER THAN 3 AMP. RISK OF BOARD DAMAGE AND FIRE MAY RESULT.
- ⚠ TRANSFORMER MAY OR MAY NOT HAVE A CIRCUIT BREAKER
- ⚠ SELECT CORRECT LINE VOLTAGE TAP. RED-280V, ORANGE-240V (FACTORY)

COILS-BLOWER COIL UNITS	
BCE4MS	
11/14	Supersedes
Form No. 537793-01	

© 2014

Figure 14. BCE4MS Air Handler Unit Typical Wiring Diagram

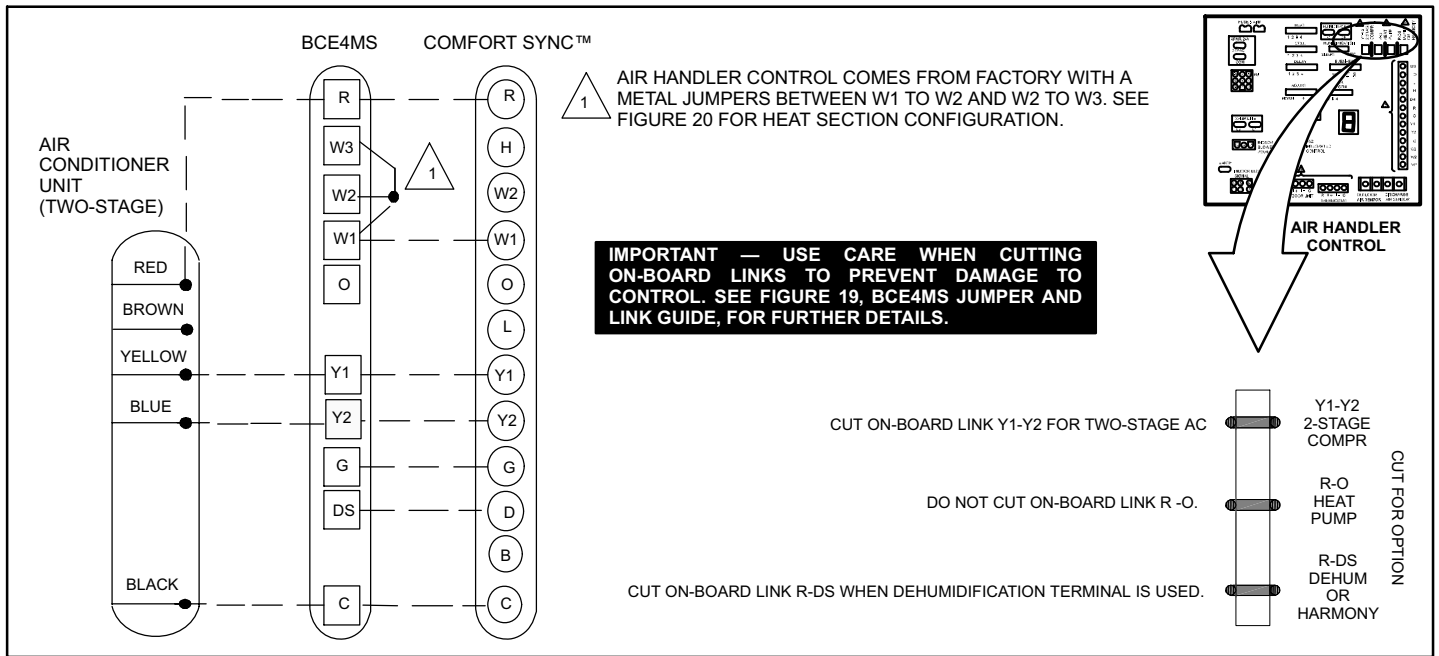

**Figure 15. Control (Field Wiring) — Cooling Application (Non-Communicating)**

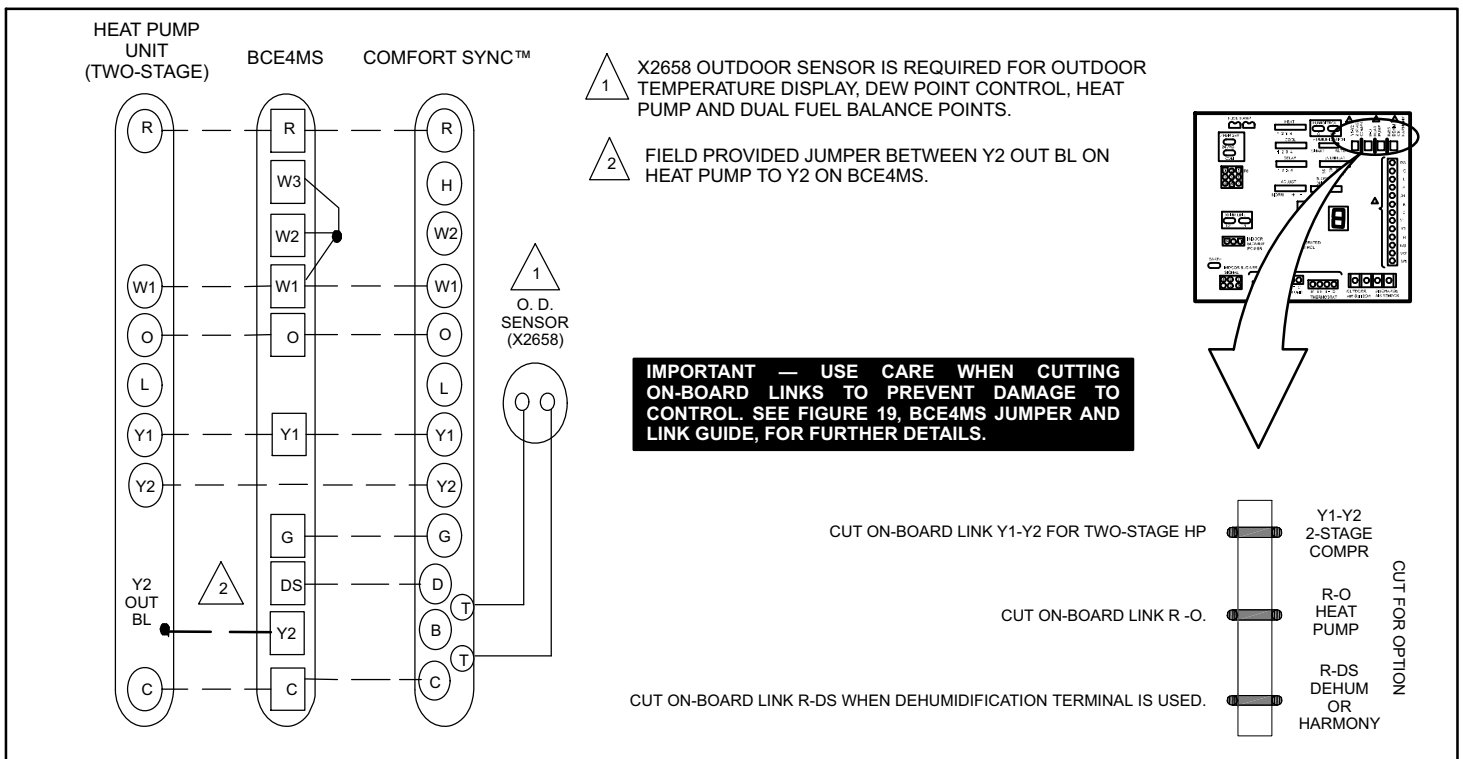
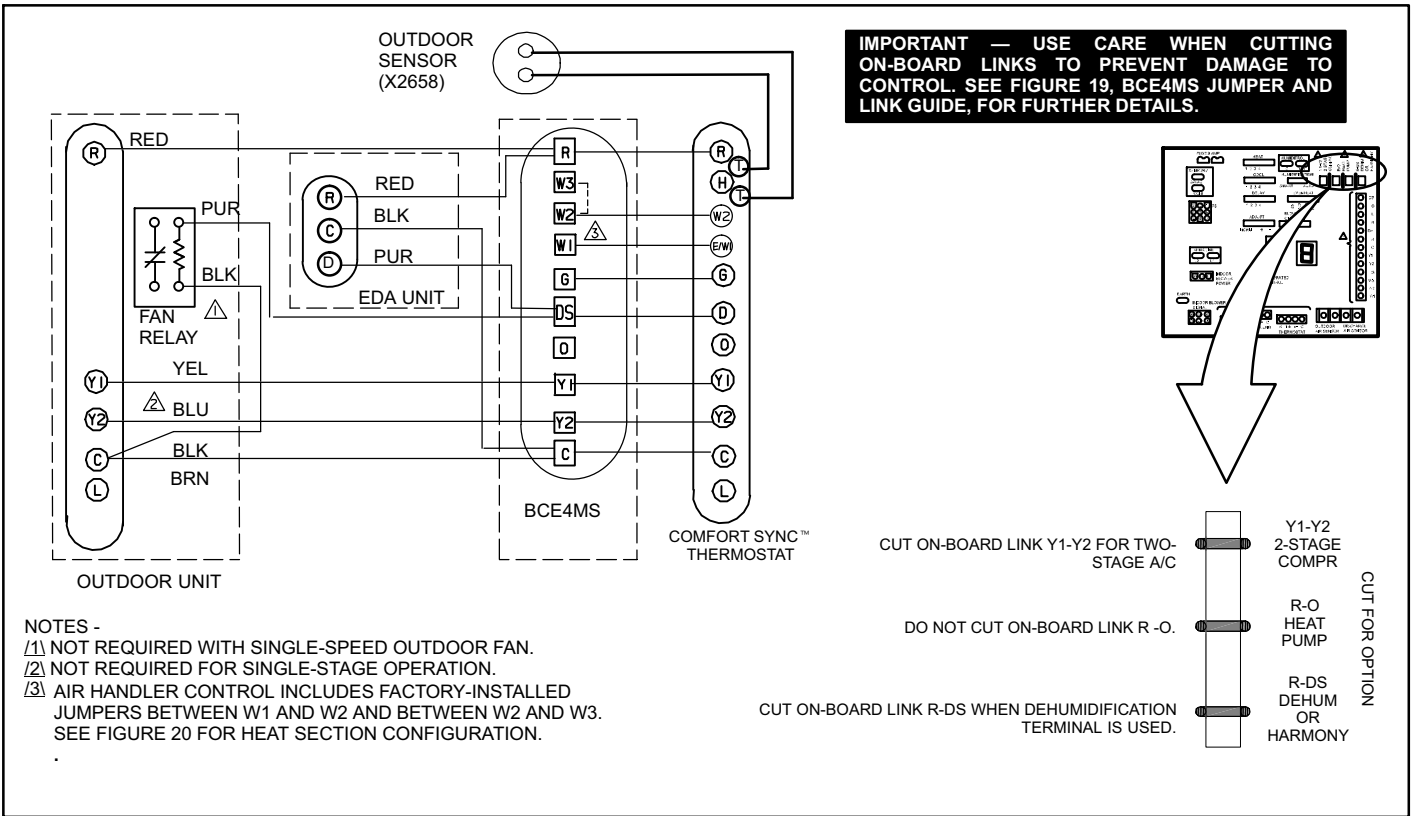

**Figure 16. Control (Field Wiring) — Heat Pump (Non-Communicating)**

## ⚠ CAUTION

### ELECTROSTATIC DISCHARGE (ESD) Precautions and Procedures

Electrostatic discharge can affect electronic components. Take precautions during unit installation and service to protect the unit's electronic controls. Precautions will help to avoid control exposure to electrostatic discharge by putting the unit, the control and the technician at the same electrostatic potential. Neutralize electrostatic charge by touching hand and all tools on an unpainted unit surface before performing any service procedure



**Figure 17. Control (Field Wiring) — Cooling Application (Humidification Control and Second-Stage Outdoor Fan Relay Wiring) Non-Communicating**

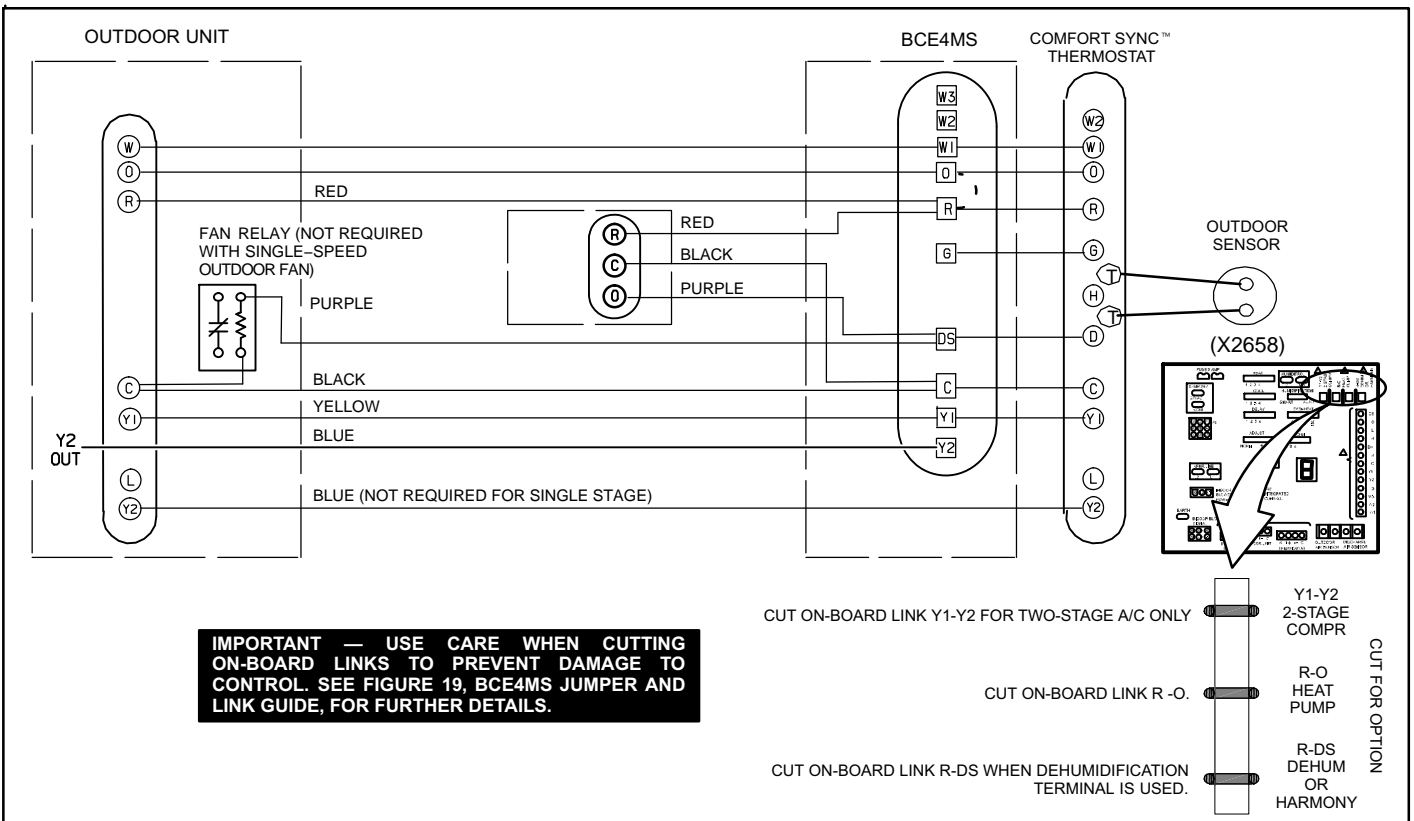

**Figure 18. Control (Field Wiring) — Heat Pump Application (Humidification Control and Second-Stage Outdoor Fan Relay Wiring) Non-Communicating**



## SENSOR CONNECTIONS AND WIRING REQUIREMENTS

The following are installation and wiring requirements for the optional outdoor air sensor.

### Outdoor Air Sensor

There is a two-screw terminal for connection to an X2658 outdoor temperature sensor. The control takes no action on the sensor status other than to communicate the temperature to the RSBus network. Wiring distance between the air handler control and outdoor temperature sensor should not exceed 200 feet when wired with 18-gauge thermostat wire.

- Minimum temperature: -40°F (-40°C)
- Maximum temperature: 70°F (158°C)

### AIR HANDLER CONTROL 9-PIN CONNECTOR (P8)

1. Air Handler (no electric heat) — Two-wire factory harness (wired to pins 7 and 8) which provides 230 VAC power to Air Handler Control.
2. Air Handler (with electric heat) — Six-wire factory harness (pin positions are wired as noted in table 5).

**Table 5. Electric Heat Connection (P8)**

Position	Function / Description
1	Heat stage 1 relay coil
2	Heat stage 2 relay coil
3	Relay coil return
4	Not used
5	Not used
6	Not used
7	L1 230VAC supply from heater kit
8	L2 230 VAC supply from heater kit
9	230 VAC sequencer first stage activation feedback

## CONTROL CONNECTIONS AND WIRING REQUIREMENTS

This sections provides information on communicating and non-communicating control connections and wire run lengths.

**Table 6. Air Handler Control Connections — Communicating**

Label	Label	Function
Thermostat	R	24VAC
	i+	RSbus data high connection
	i-	RSbus data low connection
	C	24VAC command (ground)
Outdoor Unit	R	24VAC
	i+	RSbus data high connection
	i-	RSbus data low connection
	C	24VAC command (ground)
Link	i+	Not used.
	i-	

**Table 7. Run Length — Communicating**

Wire Run Length	AWG #	Insulation/Core Types
Maximum length of wiring for all connections on the RSbus is limited to 1500 feet (457 meters).	18	Color-coded, temperature rating 95°F (35°C) minimum, solid core. (Class II Rated Wiring)

**Table 8. Run Length — Non-Communicating**

Wire Run Length	AWG #	Insulation/Core Types
Less than 100' (30m)	18	Color-coded, temperature rating 95°F (35°C) minimum, solid core. (Class II Rated Wiring)
More than 100' (30m)	16	

**Table 9. Air Handler Control Connections — Non-Communicating**

Label	Function
<b>W1 (Input)</b>	Used with a non-communicating thermostat to indicate a first-stage heating demand. This input is an anticipator current for the thermostat.
<b>W2 (Input)</b>	Used with a non-communicating thermostat to indicate a second-stage heating demand. W1 input must be active to recognize second-stage heat demand.
<b>Y1 &amp; Y2 (Input / Output)</b>	The first- and second-stage compressor contactor is connected to the Y1 and Y2 terminals. They are inputs when used with a <b>non-communicating</b> thermostat. A 24VAC signal indicates the presence of a demand. This signal is then passed through to the outdoor unit. During a second-stage demand, both Y1 and Y2 are active. In a <b>communicating</b> system they are outputs to a <b>non-communicating outdoor unit</b> . When a first- or second-stage compressor demand is indicated by serial message from the controller, a 24VAC signal is generated on Y1 and Y2. These signals are hard-wired to the outdoor unit. During a second-stage demand, both Y1 and Y2 are active. In a <b>communicating</b> system with <b>communicating outdoor unit</b> , Y1 and Y2 terminals are not used.
<b>G (Input)</b>	It is used with a non-communicating thermostat to indicate a indoor blower demand. A 24VAC signal indicates the presence of a demand. In communicating system <b>G</b> input is used by non-communicating IAQ devices (such as LVCS, HRV or ERV) to indicate indoor blower demand.
<b>C</b>	This terminal shall interconnect the signal ground of the thermostat with secondary transformer ground (TR) and chassis ground (GND).
<b>R</b>	This terminal is capable of providing the power to the thermostat and all the associated loads.
<b>O (Input / Output)</b>	The <b>O</b> terminal is used with heat pump units to power the reversing valve. The <b>O</b> terminal is connected to <b>R</b> by jumper wire that would be cut if a heat pump was used. It is used with a non-communicating thermostat as input to set the heat pump to cooling or heating mode. A 24VAC signal sets the heat pump to cooling mode; an open circuit sets the heat pump to heating mode. This signal is passed through to the heat pump. In a <b>communicating</b> system <b>O</b> is an output to a non-communicating heat pump. The air handler controls the output based on received RSbus messages. A 24VAC signal is generated on O for cooling operation, while terminal is open for heat pump operation.
<b>DS (Input)</b>	This terminal is used in non-communicating systems with zoning systems, or thermostats with dehumidification capability.
<b>DH (Output)</b>	This terminal provides a 24VAC output for dehumidification needs in communicating systems.
<b>H (Output)</b>	This terminal provides a 24VAC output for humidification needs in both communicating and non-communicating mode.

# JUMPER & LINK GUIDE

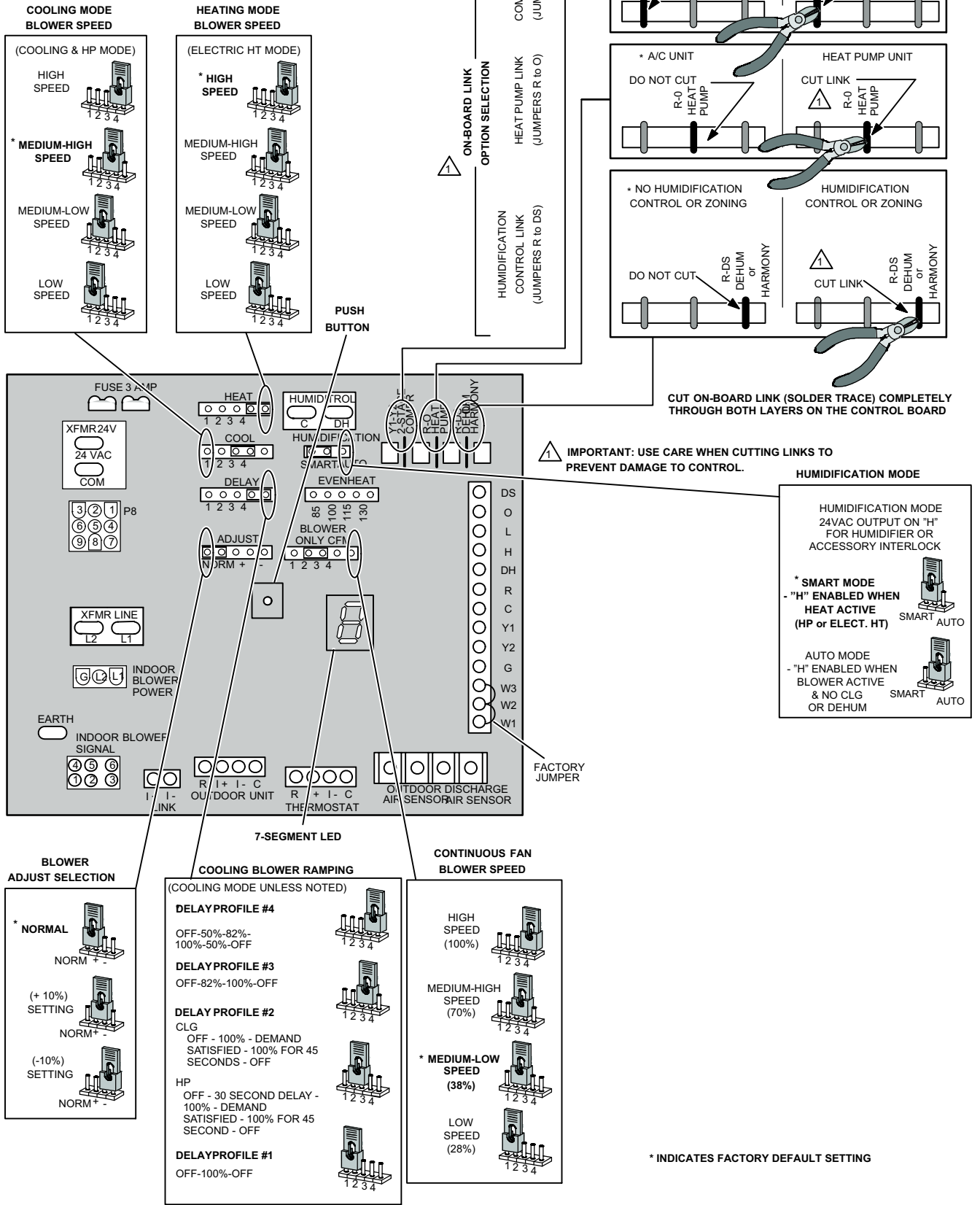

Figure 19. Air Handler Configuration

## Air Handler Control Button, Display and Jumpers

Use figure 19 as reference for jumper settings. If any of the referenced jumpers are missing, the Air Handler Control will display Error Code **130** as per table 10, and the Air Handler Control will automatically use the **factory default** setting show in figure 19)

### ⚠ IMPORTANT

Before changing any clippable links or jumper settings, make sure the motor has completely stopped. Any changes will not take place while the motor is running.

#### PUSH BUTTON

An on-board push button is provided for the purpose of placing the air handler control in different operation modes and can be used to recall stored error codes. When button is pushed and held, air handler control will cycle through a menu of options depending on current operating mode. Every three seconds a new menu item will be displayed. If the button is released while that item is shown on the display, air handler control will enter displayed operating mode, or execute defined operation sequence for that menu option. Once all items on menu have been displayed the menu resumes from the beginning (if button is still held).

1. Press the diagnostic push button and hold it to cycle through a menu of options. Every three seconds a new menu item will be displayed. Release the button when the desired mode is displayed.
2. When the solid "E" is displayed, the control enters the Error Code Recall mode. Error Code Recall mode menu options: No change (displaying error history) remains in Error Code Recall mode; solid "≡" exits Error Code Recall mode; and solid "c" clears the error history. Must press button while flashing "c" is displayed to clear error codes
3. When the solid "-" is displayed, the control enters the applicable mode. Field configuration mode menu options: Solid "C" starts pressure switch calibration; blinking "-" exits current active mode.

#### JUMPERS

Jumpers are used for non-communicating mode only.

1. **Humidification** — Controls the status of **H** terminal on the thermostat block. Configurations are as follows:
  - If jumper is installed in **SMART** Humidification position (Default), **H** terminal is active if heat demand is present and indoor blower is running.
  - If jumper is installed in **AUTO** Humidification position, **H** terminal is energized whenever indoor blower is running.
2. **Blower Only CFM** — Used to select Indoor blower CFM for continuous operation.
3. **Heat** — Used to select Indoor blower CFM for electrical heat by placing the jumper in proper position. Actual CFM values for different air handler sizes are shown in *Targeted CFM tables* starting on page 25.

4. **Cool** — Used to select cooling indoor blower CFM by placing the jumper in proper position. Actual CFM values for different air handler sizes are shown in *Targeted CFM tables* starting on page 25.
5. **Adjust** - Used to select the indoor blower CFM adjustment value by placing the jumper in appropriate position.
  - If **NORM** is selected, indoor blower runs at normal speeds.
  - If **+** is selected, indoor blower runs at approximately 10% higher speed than NORM setting.
  - If **-** is selected, indoor blower runs at approximately 10% lower speed than NORM setting.

If the jumper is missing, the Air Handler Control will activate the *Configuration Jumper is Missing* alarm in and will automatically use the default factory setting in table 10. See figure 19 for jumper configurations. Actual CFM values for different air handler sizes are shown in *Targeted CFM tables* starting on page 25.

6. **Delay** — Indoor blower cooling profile, delay for cooling and heat pump operations.
  - For heat pump **heating** operation only delay profiles 1 and 2 are applicable. If profiles 3 or 4 have been selected, heat pump operation will use profile 1 only.
  - For heat pump **cooling** operation all 4 profiles are operational.

If the jumper is missing, the Air Handler Control will activate the *Configuration Jumper is Missing* alarm and will automatically use the default factory setting in table 10. See figure 19 for jumper configurations.

#### Delay Profile 1

- A When cool or heat demand is initiated, motor ramps up to 100% and runs at 100% until demand is satisfied.
- B Once demand is met, motor ramps down to stop.

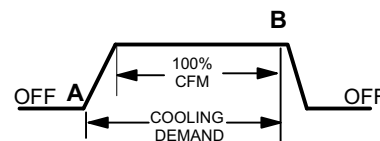

#### Delay Profile 2

Cooling — Air Conditioner and Heat Pump:



- A When cool demand is initiated, motor ramps up to 100% and runs at 100% until demand is satisfied.
- B Once demand is met, motor runs at 100% for 45 seconds.
- C Motor ramps down to stop.

**Heating — Heat Pump only:**

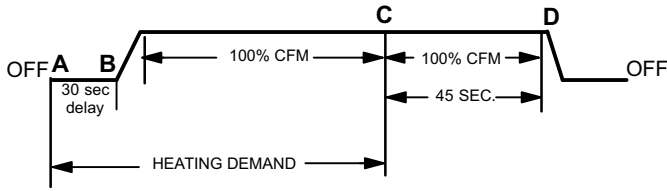

- A** When heat demand is initiated, 30 seconds motor on delay starts
- B** After the motor on delays expires, motor ramps up to 100% and runs at 100% until demand is satisfied.
- C** Once demand is met, motor runs at 100% for 45 seconds.
- D** Motor ramps down to stop.

**Delay Profile 3**

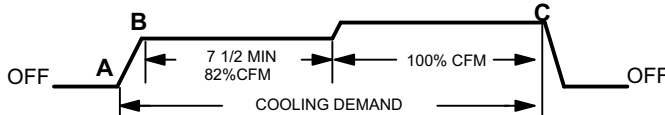

- A** When cool demand is initiated, motor ramps up to 82%

- B** Motor runs at 82% for approximately 7.5 minutes and then ramp up to 100% (unless the demand has been satisfied) and motor runs at 100% until demand is satisfied.
- C** Once demand is met, motor ramps down to stop

**Delay Profile 4**

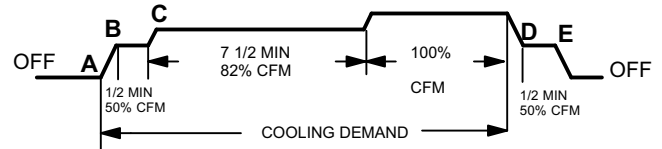

- A** When cool demand is initiated, motor ramps up to 50%
- B** Motor runs at 50% for 30 seconds and ramps up to 82%
- C** Motor runs at 82% for approximately 7.5 minutes and then ramp up to 100% (unless the demand has been satisfied) and motor runs at 100% until demand is satisfied.
- D** Once demand is met, motor runs at 50% for 30 seconds.
- E** Motor ramps down to stop.

**DISPLAY**

An on-board single character LED display (see figure 19 for LED display location) indicates general system status information such as mode of operation, indoor blower CFM and error codes. Multi-character strings are displayed with character ON for one second, OFF for 0.5 seconds and one second pause between the character groups.

**Table 10. Air Handler Control System Status Codes**

Single Character Display	Action
<b>Letter or Number</b>	Unit Size Code displayed represents air handler model size and capacity. See <i>Configuring Unit Size Codes</i> in figure 21.
— — —	If three horizontal bars are displayed, control does not recognize air handler model size and capacity. See <i>Configuring Unit Size Codes</i> in Figure 21.
.	Idle mode (decimal point / no unit operation).
A	Cubic feet per minute (cfm) setting for indoor blower (1 second ON, 0.5 second OFF) / cfm setting for current mode displayed. Example: A 1200.
⌈	Cooling stage (1 second ON, 0.5 second OFF) / 1 or 2 displayed / Pause / cfm setting displayed / Pause / Repeat codes. Example: ⌈ 1 or ⌈ 2.
d	Dehumidification mode (1 second ON / 1 second OFF) / cfm setting displayed / Pause / Repeat codes.
d F	Defrost mode. (Y, W and O call).
H	Heat stage (1 second ON, 0.5 second OFF) / Active electric heat stage displayed / Pause / cfm setting displayed / Pause / Repeat codes. Example: H 1 or H 2.
h	Heat pump stage (1 second ON, 0.5 second OFF) / Active heat pump stage displayed / Pause / cfm setting / Pause / Repeat codes. Example: h 1 or h 2.

**Table 11. Air Handler Control Configuration, Test and Error Recall (Fault and Lockout) Function**

<b>NOTE — AIR HANDLER CONTROL MUST BE IN IDLE MODE</b>		
<b>Single Character LED Display</b>		<b>Action</b>
Solid	—	Push and hold button until solid appears, release button. Display will blink.
Blinking	—	Push and hold button until required symbol displays. <i>HA</i> or <i>P</i> .
<b>CONFIGURING ELECTRIC HEAT SECTIONS</b>		
Solid	<i>H</i>	Release push button - control will cycle the indoor blower motor <b>on</b> to the selected heat speed and stage the electric heat relays <b>on</b> and <b>off</b> to automatically detect number of electric heat sections. Control will store the number of electric heat sections. Control will automatically exit <b>current active mode</b> .
<b>INDOOR BLOWER TEST</b>		
Solid	<i>R</i>	Release push button - control cycles indoor blower on for ten seconds at 70% of maximum air for selected unit capacity. Control will automatically exit <b>field test mode</b> .
<b>CONFIGURING UNIT SIZE CODES</b>		
<b>Single Character LED Display</b>		<b>Action</b>
Solid	<i>P</i>	<b>RELEASE</b> push button - This mode allows the field to select a unit size code (number or letter) that matches the air handler model size and capacity. <b>IMPORTANT — All field replacement controls may be manually configured to confirm air handler model size and capacity.</b>
Blinking	<i>P</i>	<ol style="list-style-type: none"> <li>When the correct <b>Unit Sized Code</b> is displayed, <b>RELEASE</b> push button. Selected code will flash for 10 seconds.</li> <li>During ten-second period, <b>HOLD</b> push button until code stops blinking (three seconds minimum).</li> <li>Air Handler Control will store code in memory and exit <b>current active mode</b>. LED display will go blank and then the <b>Unit Size Code</b> will display for 2 to 5 seconds.</li> </ol> <p><b>NOTE</b> - If ten-second period expires, or push button is held less than 3 seconds, control will automatically exit <b>current active mode</b> and go into <b>IDLE Mode</b> without storing unit size code. If this occurs, then <b>Unit Size Code</b> configuring procedure must be repeated.</p>
<b>ERROR CODE RECALL MODE (NOTE — CONTROL MUST BE IN IDLE MODE)</b>		
Solid	<i>E</i>	To enter <b>Error Code Recall Mode</b> — <b>PUSH</b> and <b>HOLD</b> button until solid <b>E</b> appears, then <b>RELEASE</b> button. Control will display up to ten error codes stored in memory. If <b>E000</b> is displayed, there are no stored error codes.
Solid	— — —	To exit <b>Error Code Recall Mode</b> — <b>PUSH</b> and <b>HOLD</b> button until <b>solid three horizontal bars</b> appear, then <b>RELEASE</b> button. <i>NOTE - Error codes are not cleared.</i>
Solid	<i>C</i>	To clear error codes stored in memory, continue to <b>HOLD</b> push button while the three horizontal bars are displayed. Release push button when solid <b>C</b> is displayed.
Blinking	<i>c</i>	Push and hold for one (1) second, release button. Seven-segment will display 0000 and exit error recall mode.

**Table 12. Air Handler Control Single Character Display Alert Codes (Communicating and Non-Communicating)**

Alert Code	Priority	Alert	How to Clear
E 105	Critical	The air handler has lost communication with the rest of the system.	Equipment is unable to communicate. This may indicate the existence of other alarms / codes. In most cases errors are related to electrical noise. Make sure high voltage power is separated from RSBus. Check for mis-wired and/or loose connections between the thermostat, indoor unit and outdoor unit. Check for a high voltage source of noise close to the system. Generally, this is a self-recoverable error.
E 114	Critical	There is a frequency/distortion problem with the power to the air handler.	This alarm/code may indicate transformer overloading. Check the voltage and line power frequency. Check the generator operating frequency, if the system is running on back-up power. Correct voltage and frequency problems. System resumes normal operation 5 seconds after fault recovered.
E 115	Critical	The 24VAC to the air handler control is lower than the required range of 18 to 30VAC.	24-volt power low (range is 18 to 30 volts). Check and correct voltage. Check for additional power-robbing equipment connected to system. This alarm / code may require the installation of an additional or larger VA transformer.
E 120	Moderate	There is a delay in the air handler responding to the system.	Typically, this alarm/code does not cause any issues and will clear on its own. The alarm/code is usually caused by a delay in the outdoor unit responding to the thermostat. Check all wiring connections. Cleared after unresponsive device responds to any inquiry.
E 124	Critical	The Comfort Sync™ thermostat has lost communication with the air handler for more than 3 minutes.	Equipment lost communication with the Comfort Sync™ thermostat. Check the wiring connections, ohm wires and cycle power. The alarm stops all associated HVAC operations and waits for a heartbeat message from the unit that is not communicating. The alarm/fault clears after communication is re-established.
E 125	Critical	There is a hardware problem with the air handler control.	There is a control hardware problem. Replace the control if the problem prevents operation and is persistent. The alarm / fault is cleared 300 seconds after the fault recovers.
E 130	Moderate	An air handler configuration jumper is missing.	Configuration jumper(s) missing on control (applicable in non-communicating applications only). Replace the jumper or put wire between terminals on control. Cleared after jumper is connected.
E 131	Critical	The air handler control parameters are corrupted.	Reconfigure the system. Replace the control if heating or cooling is not available.
E 132	Critical	The air handler control software is corrupted.	Recycle power. If failure re-occurs, replace the control. System reset is required to recover.
E 180	Critical	The Comfort Sync™ thermostat has found a problem with the air handler outdoor sensor.	In normal operation after control recognizes sensors, the alarm will be sent if valid temperature reading is lost. Compare outdoor sensor resistance to temperature/resistance charts in unit installation instructions. Replace sensor pack if necessary. At the beginning of (any) configuration, the air handler control will detect the presence of the sensor(s). If detected (reading in range), appropriate feature will be set as installed and shown in the 'About' screen. The alarm / fault will clear upon configuration, or sensing normal values.
E201	Critical	The system has lost communication with the air handler indoor blower motor.	Lost communication with indoor blower motor. Possible causes include power outage, brown-out, motor not powered, loose wiring, condensation on air handler control without cover on breaker. Problem may be on control or motor side. Cleared after communication is restored.
E202	Critical	The unit size code for the air handler and the size of blower motor do not match.	Incorrect appliance unit size code selected. Check for proper configuring under unit size codes for air handler on configuration guide or in installation instructions. The alarm / fault clears after the correct match is detected following a reset. Remove the thermostat from the system while applying power and reprogramming.
E203	Critical	The unit size code for the air handler has not been selected.	No appliance unit size code selected. Check for proper configuring under: Unit size codes for air handler on configuration guide or in installation instructions. Critical Alert. The alarm / fault clears after the correct match is detected following a reset. Remove the thermostat from the system while applying power and reprogramming.
E292	Critical	The air handler's blower motor will not start.	The system will go into watchdog mode. Indoor blower motor unable to start. This could be due to seized bearing, stuck wheel, obstruction etc. Replace motor or wheel if assembly does not operate or meet performance standards. The alarm / fault clears after the indoor blower motor starts successfully.
E295	Minor	The indoor blower motor is over heating.	Indoor blower motor over temperature (motor tripped on internal protector). Check motor bearings and amps. Replace if necessary. The alarm / fault clears after blower demand is satisfied.
E312	Minor	The blower cannot provide the requested CFM due to high static.	Warning Only. Restricted airflow - Indoor blower is running at a reduced CFM (cutback mode). The variable-speed motor has pre-set speed and torque limiters to protect the motor from damage caused by operating outside of design parameters (0 to 0.8" e.g.. total external static pressure). Check filter and duct system. To clear, replace filter if needed or repair/add duct. The alarm/fault is cleared after the current service demand is satisfied.
E313	Minor	The indoor and outdoor unit capacities do not match.	Check for proper configuring in installation instructions. Alarm is just a warning. The system will operate, but might not meet efficiency and capacity parameters. The alarm will clear after commissioning is complete.

**Table 12. Air Handler Control Single Character Display Alert Codes (Communicating and Non-Communicating)  
(continued)**

Alert Code	Priority	Alert	How to Clear
E345	Critical	The <b>O</b> relay on the air handler has failed. Either the pilot relay contacts did not close or the relay coil did not energize.	<b>O</b> relay failed. Pilot relay contacts did not close or the relay coil did not energize. Replace control. The alarm clears after a reset
E346	Critical	The <b>R</b> to <b>O</b> jumper was not removed on the air handler control.	Configuration link(s) not removed on control. Cut / remove <b>R</b> to <b>O</b> jumper. Applicable with non communicating outdoor unit with communicating indoor unit. The fault clears after the <b>R</b> to <b>O</b> jumper is cut/removed.
E347	Critical	The <b>Y1</b> relay on the air handler has failed. Either the pilot relay contacts did not close or the relay coil did not energize.	Operation stopped. Y1 relay failed. Pilot relay contacts did not close or the relay coil did not energize. The indoor unit cannot verify that the relay is closed. The alarm clears after a reset and Y1 input sensed.
E348	Critical	The <b>Y2</b> relay on the air handler has failed. Either the pilot relay contacts did not close or the relay coil did not energize.	Operation stopped. Y2 relay failed. Pilot relay contacts did not close or the relay coil did not energize. The indoor unit cannot verify that the relay is closed. The alarm clears after a reset and Y2 input sensed.
E350	Critical	The air handler's electric heat is not configured.	Heat call with no configured or mis-configured electric heat. Configure electric heat in the air handler. The fault clears electrical heat is successfully detected.
E351	Critical	There is a problem with the air handler's first-stage electric heat. Either the pilot relay contacts did not close, or the relay coil in the electric heat section did not energize.	Heat section / stage 1 failed. Pilot relay contacts did not close, or the relay coil in the electric heat section did not energize. The alarm clears after stage 1 relay is detected.
E352	Moderate	There is a problem with the air handler's second-stage electric heat. Either the pilot relay contacts did not close, or the relay coil in the electric heat section did not energize. The air handler will operate on first stage electric heat until the issue is resolved.	Heat section / stage 2 failed (same as code 351). Pilot relay contacts did not close, or the relay coil in the electric heat section did not energize. The air handler will operate on stage 1 heat only. The alarm clears after stage 2 relay is detected.
E409	Moderate	The secondary voltage for the air handler has fallen below 18VAC. If this continues for 10 minutes, the Comfort Sync™ thermostat will turn off the air handler.	Secondary voltage is below 18VAC. After 10 minutes, operation is discontinued. Check the indoor line voltage, transformer output voltage. The alarm clears after the voltage is higher than 20VAC for 2 seconds or after a power reset.



## Target CFM Tables

### BCE4M24S BLOWER PERFORMANCE

0 through 0.80 in. w.g. External Static Pressure Range

"AJUST" Jumper Setting	Jumper Speed Positions							
	"HEAT" Speed				"COOL" Speed			
	1	2	3	4	1	2	3	4
	cfm	cfm	cfm	cfm	cfm	cfm	cfm	cfm
+	715	855	1000	1130	465	690	900	1050
NORM	670	770	900	1035	425	620	825	950
-	580	700	800	930	385	560	735	850

#### NOTES:

- The effect of static pressure, filter and electric heater resistance is included in the air volumes listed.
- First stage cooling air volume is 70% of COOL speed settings. Continuous fan speed is approximately 28%, 38%, 70% and 100% (Jumper selectable) of the same second-stage COOL speed selected, minimum 250 cfm.

### BCE4M30S BLOWER PERFORMANCE

0 through 0.80 in. w.g. External Static Pressure Range

"AJUST" Jumper Setting	Jumper Speed Positions							
	"HEAT" Speed				"COOL" Speed			
	1	2	3	4	1	2	3	4
	cfm	cfm	cfm	cfm	cfm	cfm	cfm	cfm
+	800	935	1070	1210	660	880	1100	1320
NORM	725	850	975	1100	600	800	1000	1200
-	655	765	880	990	540	720	900	1080

#### NOTES:

- The effect of static pressure, filter and electric heater resistance is included in the air volumes listed.
- First stage cooling air volume is 70% of COOL speed settings. Continuous fan speed is approximately 28%, 38%, 70% and 100% (Jumper selectable) of the same second-stage COOL speed selected, minimum 250 cfm.

### BCE4M36S BLOWER PERFORMANCE

0 through 0.80 in. w.g. External Static Pressure Range

"AJUST" Jumper Setting	Jumper Speed Positions							
	"HEAT" Speed				"COOL" Speed			
	1	2	3	4	1	2	3	4
	cfm	cfm	cfm	cfm	cfm	cfm	cfm	cfm
+	1230	1335	1445	1545	900	1225	1380	1545
NORM	1120	1215	1315	1400	810	1125	1275	1400
-	1010	1185	1200	1265	730	1000	1135	1265

#### NOTES:

- The effect of static pressure, filter and electric heater resistance is included in the air volumes listed.
- First stage cooling air volume is 70% of COOL speed settings. Continuous fan speed is approximately 28%, 38%, 70% and 100% (Jumper selectable) of the same second-stage COOL speed selected, minimum 250 cfm.

## BCE4M48S and BCE4M60S BLOWER PERFORMANCE

0 through 0.80 in. w.g. External Static Pressure Range

"AJUST" Jumper Setting	Jumper Speed Positions							
	"HEAT" Speed				"COOL" Speed			
	1 cfm	2 cfm	3 cfm	4 cfm	1 cfm	2 cfm	3 cfm	4 cfm
+ <b>NORM</b> -	1850	1960	2090	2150	1625	1820	2055	2145
	1705	1800	1900	2005	1425	1625	1805	2005
	1560	1625	1720	1770	1205	1375	1555	1725

### NOTES:

- The effect of static pressure, filter and electric heater resistance is included in the air volumes listed.
- First stage cooling air volume is 70% of COOL speed settings. Continuous fan speed is approximately 28%, 38%, 70% and 100% (Jumper selectable) of the same second-stage COOL speed selected, minimum 450 cfm.

## Unit Operating Sequence

This section details unit operating sequence for non-communicating systems.

*NOTE* - For communicating systems, see the Comfort Sync™ thermostat installation instruction.

**Table 13. BCE4MS with Non-Communicating Thermostat and Single-Stage Outdoor Unit Operating Sequence**

Operating Sequence		System Demand								System Response		
System Condition	Step	Thermostat Demand						Relative Humidity		Comp	Air Handler CFM (COOL)	Comments
		Y1	Y2	O	G	W1	W2	Status	D			
<b>NO CALL FOR DEHUMIDIFICATION</b>												
Normal Operation	1	On		On	On			Acceptable	24 VAC	High	100%	Compressor and indoor air handler follow thermostat demand.
<b>BASIC MODE (Only active on a Y1 thermostat demand)</b>												
Normal Operation	1	On		On	On			Acceptable	24 VAC	High	100%	Thermostat energizes Y1 and de-energizes D on a dehumidification demand. <i>NOTE - No over cooling.</i>
Dehumidification demand	2	On		On	On			Demand	0 VAC	High	70%	
<b>PRECISION MODE (Operates independent of a Y1 thermostat demand)</b>												
Normal Operation	1	On		On	On			Acceptable	24 VAC	High	100%	Dehumidification mode begins when humidity is greater than setpoint.
Dehumidification demand	2	On		On	On			Demand	0 VAC	High	70%	
Dehumidification demand ONLY	1	On		On	On			Demand	0 VAC	High	70%	Thermostat will keep outdoor unit energized after cooling temperature setpoint has been reached in order to maintain room humidity setpoint. <i>NOTE - Allow to cool 2°F beyond cooling setpoint.</i>

**Table 14. BCE4MS with Non-Communicating Thermostat and Two-Stage Outdoor Unit Operating Sequence**

Operating Sequence		System Demand								System Response		
System Condition	Step	Thermostat Demand					Relative Humidity			Compressor	Air Handler CFM (COOL)	Comments
		Y1	Y2	O	G	W1	W2	Status	D			
<b>No Call for Dehumidification</b>												
Normal Operation - Y1	1	On		On	On			Acceptable	24 VAC	Low	70%	Compressor and indoor air handler follow thermostat demand.
Normal Operation - Y2	2	On	On	On	On			Acceptable	24 VAC	High	100%	
<b>Room Thermostat Calls for First-Stage Cooling</b>												
<b>BASIC MODE (Only active on a Y1 thermostat demand)</b>												
Normal Operation	1	On		On	On			Acceptable	24 VAC	Low	70%	Thermostat energizes Y2 and de-energizes D on a dehumidification demand <i>NOTE - No over cooling.</i>
Dehumidification demand	2	On	On	On	On			Demand	0 VAC	High	70%	
<b>PRECISION MODE (Operates independent of a Y1 thermostat demand)</b>												
Normal Operation	1	On		On	On			Acceptable	24 VAC	Low	70%	Dehumidification mode begins when humidity is greater than setpoint.
Dehumidification demand	2	On	On	On	On			Demand	0 VAC	High	70%	
Dehumidification demand ONLY	1	On	On	On	On			Demand	0 VAC	High	70%	Thermostat will keep outdoor unit energized after cooling temperature setpoint has been reached in order to maintain room humidity setpoint. <i>NOTE - Allow to cool 2°F beyond cooling setpoint.</i>
<b>Room Thermostat Calls for First- and Second-Stage Cooling</b>												
<b>BASIC MODE (Only active on a Y1 thermostat demand)</b>												
Normal Operation	1	On	On	On	On			Acceptable	24 VAC	High	100%	Thermostat energizes Y2 and de-energizes D on a dehumidification demand. <i>NOTE — No over cooling.</i>
Dehumidification demand	2	On	On	On	On			Demand	0 VAC	High	70%	
<b>PRECISION MODE (Operates independent of a Y1 thermostat demand)</b>												
Normal Operation	1	On	On	On	On			Acceptable	24 VAC	High	100%	Dehumidification mode begins when humidity is greater than setpoint.
Dehumidification demand	2	On	On	On	On			Demand	0 VAC	High	70%	
Dehumidification demand ONLY	1	On	On	On	On			Demand	0 VAC	High	70%	Thermostat will keep outdoor unit energized after cooling temperature setpoint has been reached in order to maintain room humidity setpoint. <i>NOTE - Allow to cool 2°F beyond cooling setpoint.</i>

# Configuring Unit

This section identifies the requirements for configuring the air handler unit for unit size and heat mode selection

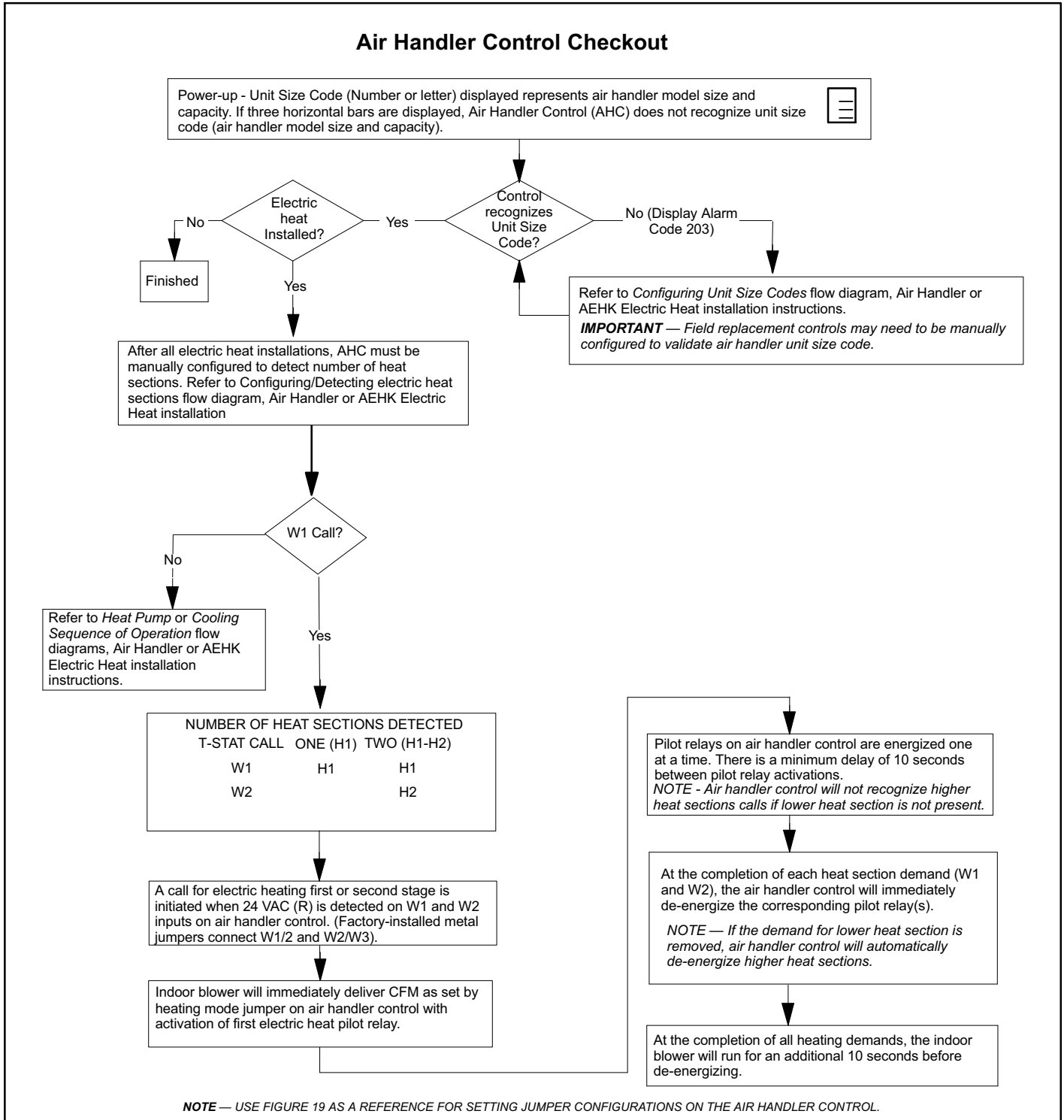

**Figure 20. Air Handler Control Checkout**

## Configuring Unit Size Codes (Model Number)

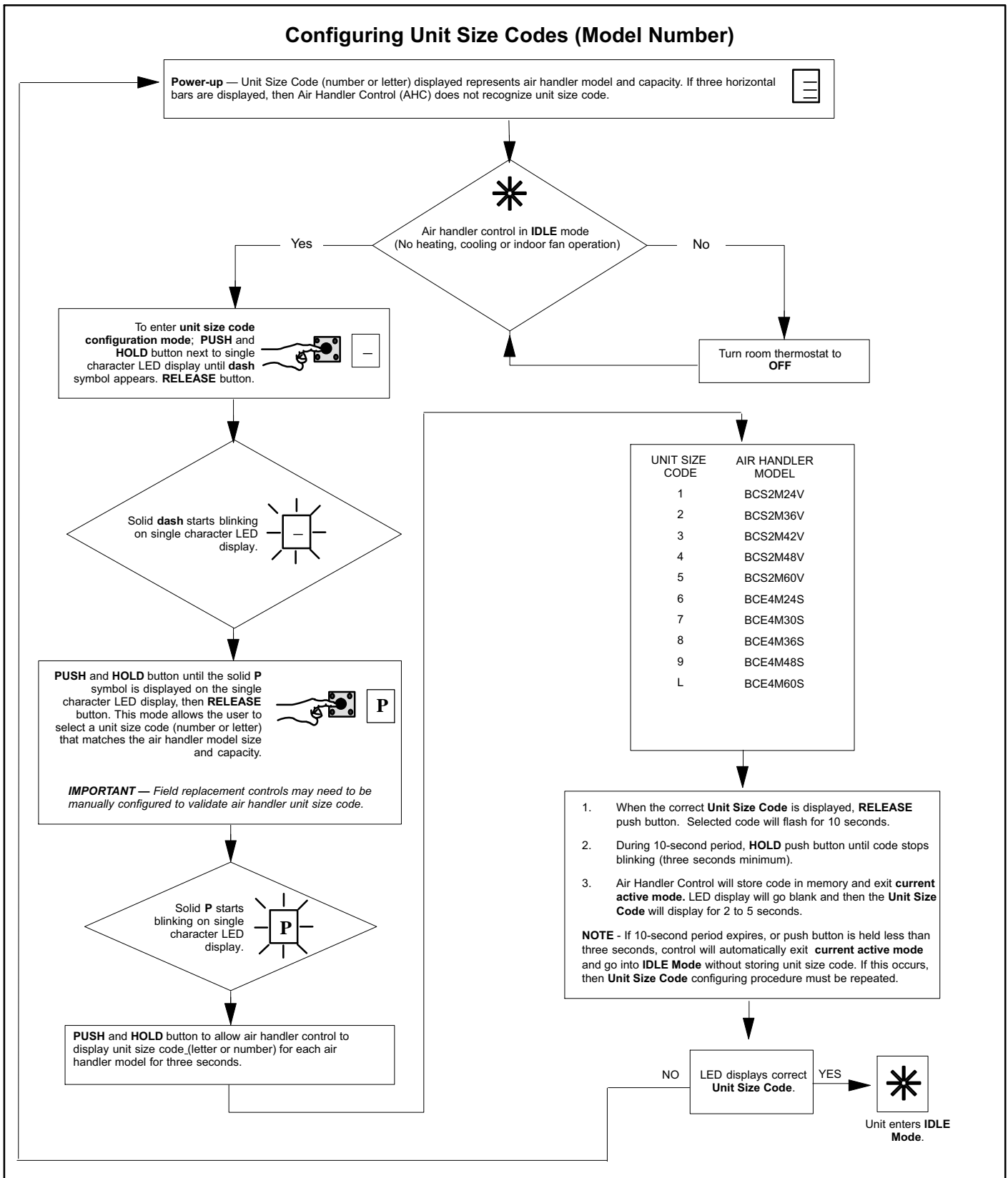

Figure 21. Configure Unit Size Codes

## Configuring/Detecting Electric Heat Sections

**IMPORTANT** — All electric heat installations require the Air Handler Control (AHC) to be manually configured to detect number of heat sections.

**NOTE** — All field replacement air handler controls must be configured to detect electric heat sections.

*NOTE - USE FIGURE 19 AS A REFERENCE FOR SETTING JUMPER CONFIGURATIONS ON THE AIR HANDLER CONTROL.*

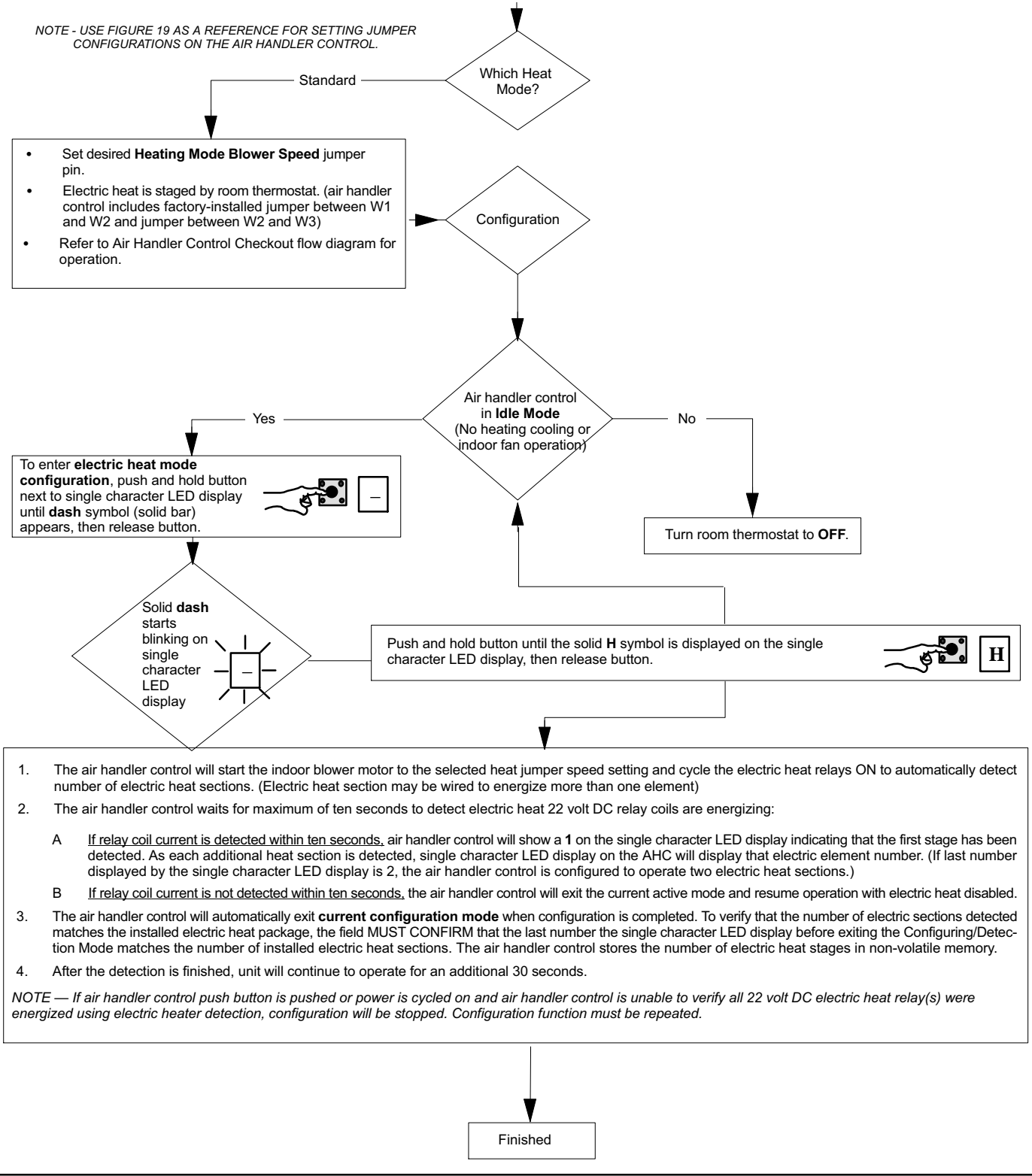

**Figure 22. Heat Mode Selection**

# Heat Pump Operation (Heating and Cooling)

## Air Handler Control (AHC) Indoor Blower Mode Speed and Profile settings

- Set **Cooling Mode Blower Speed** jumper pin. (Low and high indoor blower CFM settings are identical for cooling and heat pump)
- Set Blower Adjust Selection jumper pin.
- Set Cooling Mode Blower Ramping jumper pin (Cooling calls - All ramping profiles are active) (Heating calls - Only ramping profiles 1 and 2 are active. If profiles 3 or 4 are selected, air handler control will default to profile 1.)
  - Profile 1 does not provide any ramping profiles.
  - Profile 2 provides a 30-second indoor blower ON delay at the start of a heat pump heating demand. (45-second indoor blower **OFF** delay)
- Simultaneous Heat Pump and electric heat call: Indoor Blower will operate at the highest CFM requested by the heat pump or the electric heat blower speed selection.

### Single or Two-Stage Unit

- Air handler control on-board link must be cut between Y1 and Y2 to allow two-stage cooling operation.
- Air handler control on-board link must be cut between R and O to allow heat pump operation.

CUT ON-BOARD LINK  
Y1-Y2 FOR  
TWO-STAGE A/C

CUT ON-BOARD  
LINK R-O.

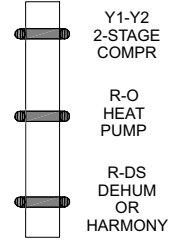

**IMPORTANT** — USE CARE WHEN CUTTING LINKS TO PREVENT DAMAGE TO CONTROL. SEE FIGURE 19, BCE4MS JUMP AND LINK GUIDE, FOR FURTHER DETAILS.

**NOTE** — USE FIGURE 19 AS A REFERENCE FOR SETTING JUMPER CONFIGURATIONS ON THE AIR HANDLER CONTROL.

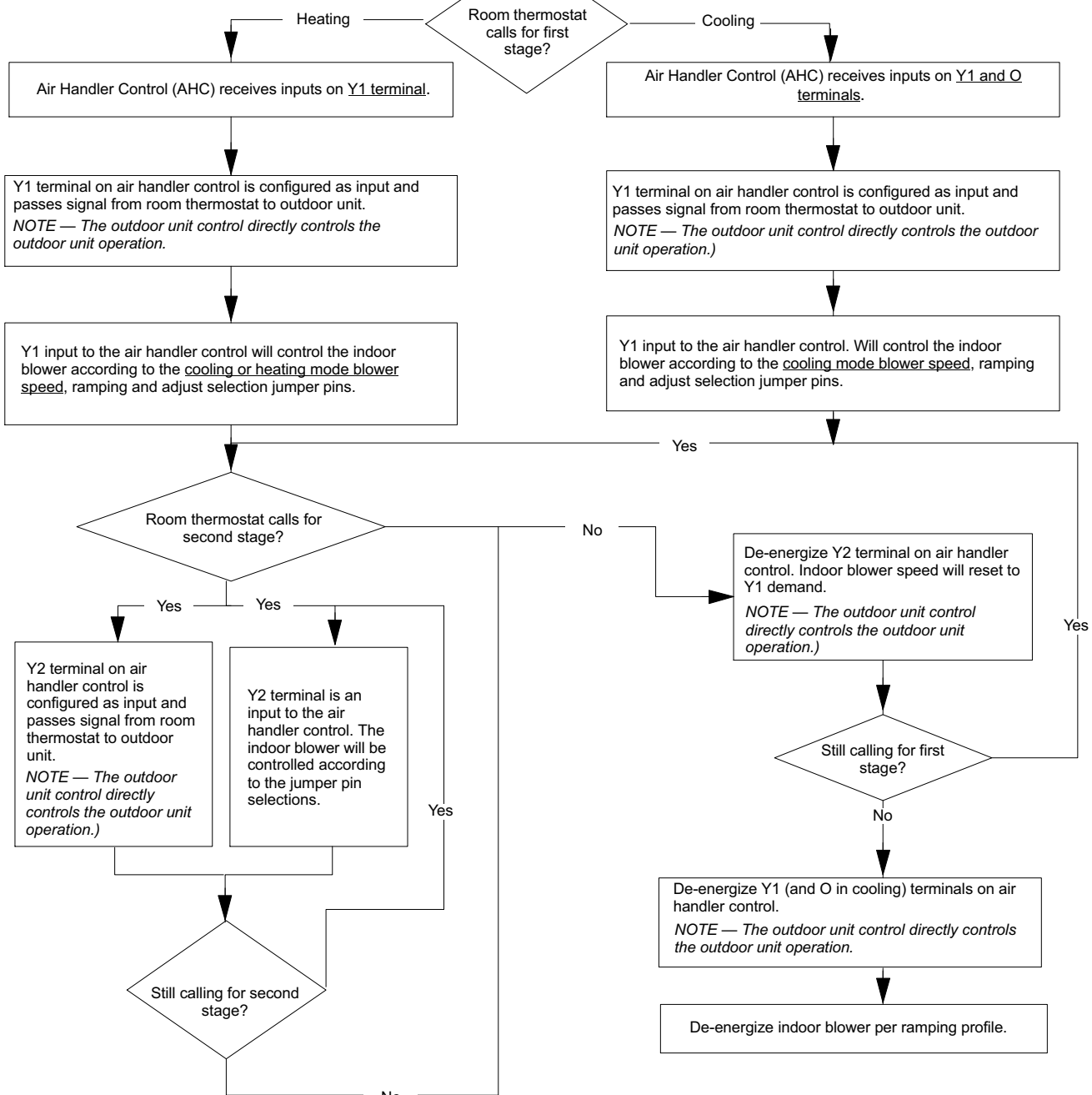



# Cooling Operation

## Air Handler Control (AHC) Indoor Blower Mode Speed and Profiles settings

1. Set **Cooling Mode Blower Speed** jumper pin.
2. Set **Cooling Mode Blower Ramping** jumper pin.
3. Set **Blower Adjust Selection** jumper pin.

### Single or Two-Stage Unit

Air handler control on-board link must be cut between Y1 and Y2 to allow two-stage cooling operation.

CUT ON-BOARD LINK Y1-Y2 FOR TWO-STAGE A/C

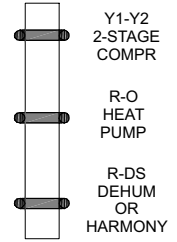

**NOTE** — USE FIGURE 19 AS A REFERENCE FOR SETTING JUMPER CONFIGURATIONS ON THE AIR HANDLER CONTROL.

**IMPORTANT** - Use care when cutting links to prevent damage to control. See figure 19, BCE4MS jump and link guide, for further details.

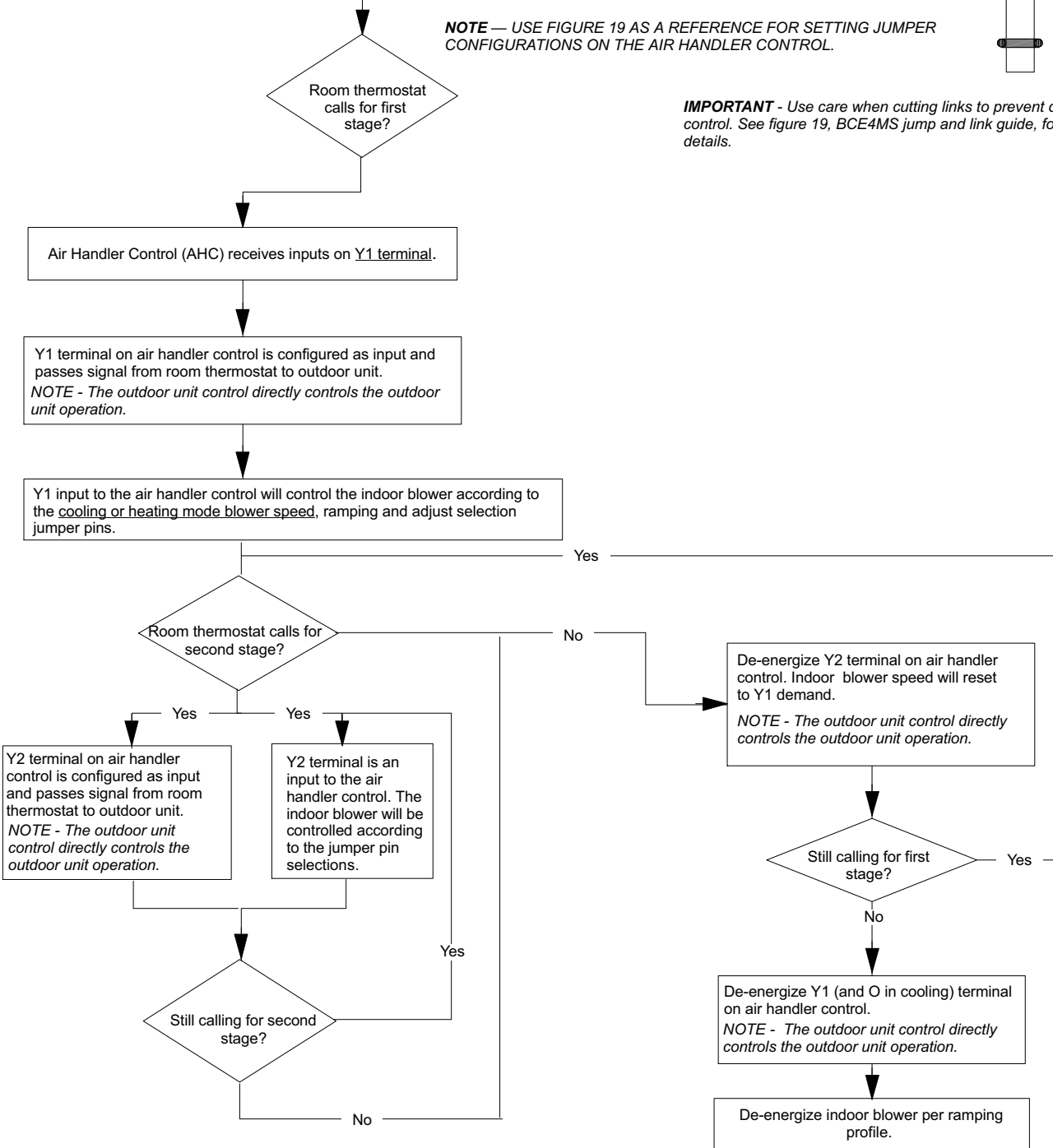

# Error Code / Recall Mode

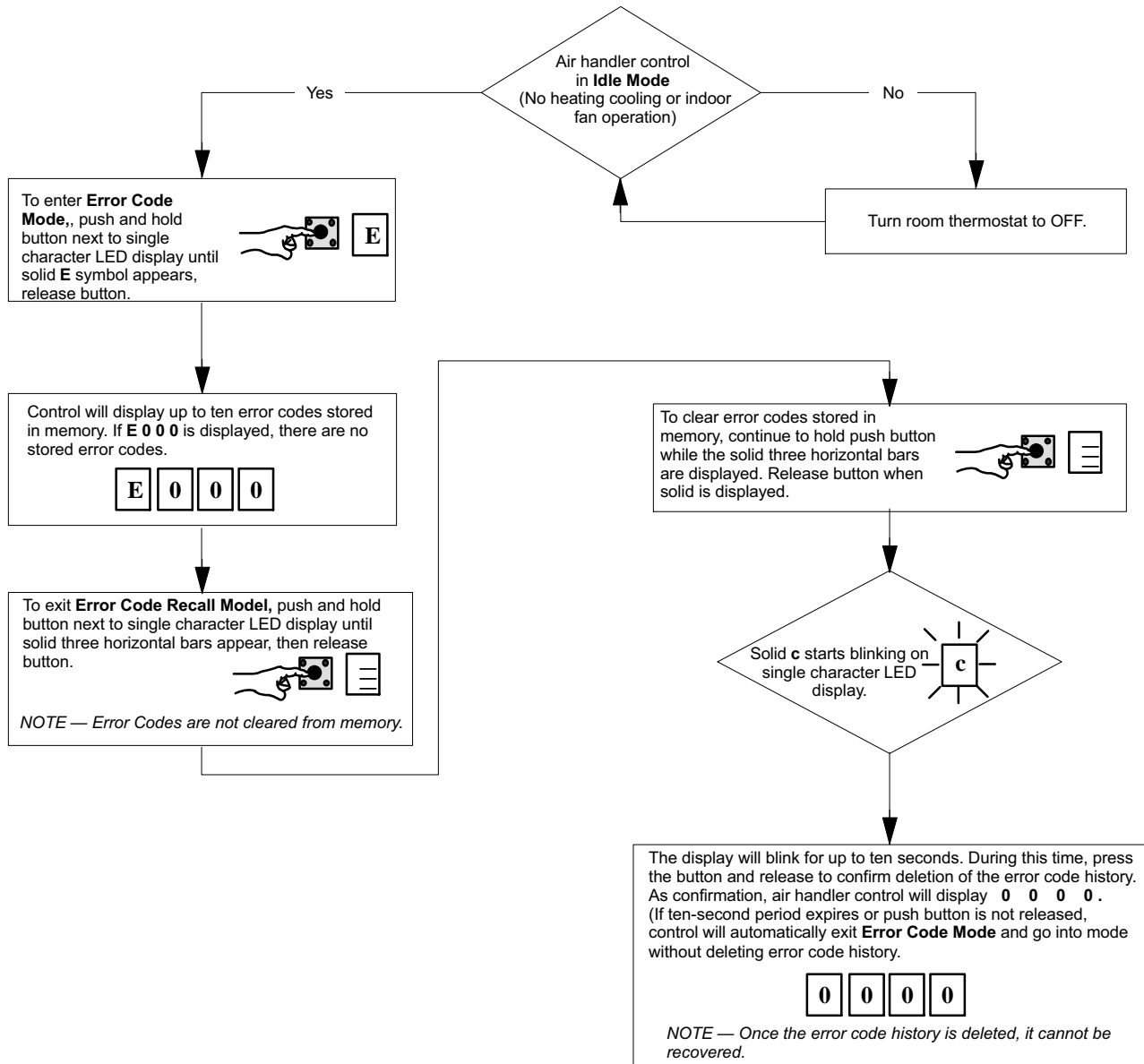

## Indoor Blower Test

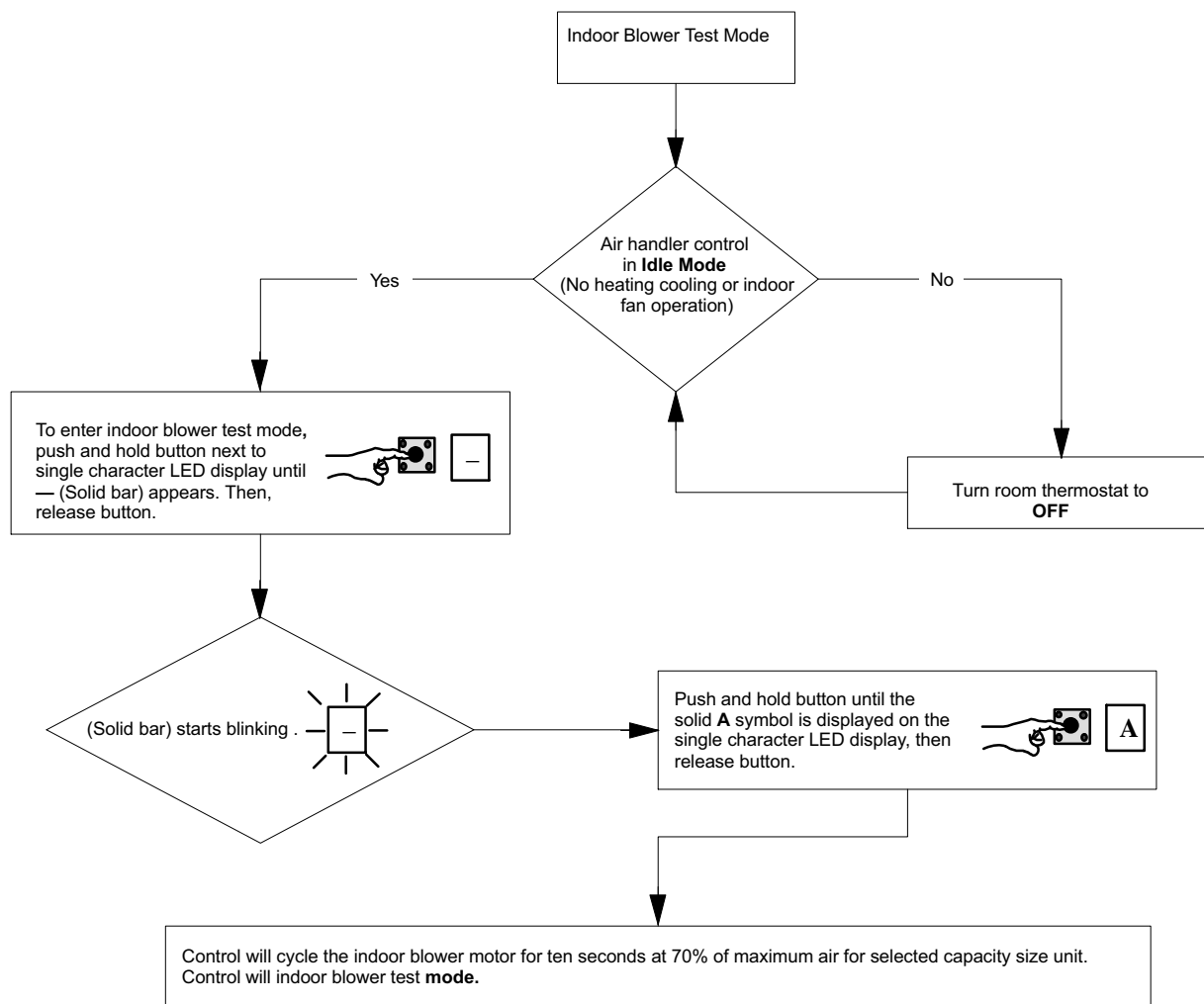

## Operation

### COOLING (COOLING ONLY OR HEAT PUMP)

When the thermostat calls for cooling, 24 volts applied to the blower time-delay relay coil. After a delay, the indoor blower relay energizes. The normally open contacts close, causing the indoor blower motor to operate. The circuit between R and Y is completed, closing the circuit to the contactor in the outdoor unit, starting the compressor and outdoor fan motor.

On heat pumps, circuit R and O energizes the reversing valve, switching the valve to the cooling position. (The reversing valve remains energized as long as the thermostat selector switch is in the COOL position.)

At the completion of the cooling demand and after the relay's timed delay, the compressor and outdoor fan will cycle off.

### HEATING (ELECTRIC HEAT ONLY)

When the thermostat calls for heat, the circuit between R and W is completed, and the heat sequencer is energized. A time delay follows before the heating elements and the indoor blower motor come on. Units with a second heat sequencer can be connected with the first sequencer to W on the thermostat subbase, or they may also be connected to a second stage on the subbase.

### HEATING (HEAT PUMP)

When the thermostat calls for heating, 24 volts is applied to the blower time-delay relay coil. After a delay, the normally open contacts close, causing the indoor blower motor to operate. The circuit between R and Y is completed, closing the circuit to the contactor in the outdoor unit, starting the compressor and outdoor fan motor. Circuit R and G energizes the blower relay, starting the indoor blower motor.

If the room temperature continues to fall, the circuit between R and W1 is completed by the second-stage heat room thermostat. Circuit R-W1 energizes a heat sequencer. The completed circuit energizes supplemental electric heat (if applicable). If the unit includes a second heat sequencer, it can be connected with the first sequencer to W1 on the thermostat. The second heat sequencer may also be connected to second-stage heating (W2) on the thermostat subbase.

### EMERGENCY HEAT (HEATING HEAT PUMP)

If the selector switch on the thermostat is set to the emergency heat position, the heat pump will be locked out of the heating circuit, and all heating demand will be satisfied by the electric heat (if applicable). A jumper should be placed between W2 and E on the thermostat subbase so that the electric heat control will transfer to the first-stage heat on the thermostat. This will allow the indoor blower to cycle on and off with the electric heat when the fan switch is in the AUTO position.

### Repairing or Replacing Cabinet Insulation

**⚠ IMPORTANT**  
**DAMAGED INSULATION MUST BE REPAIRED OR REPLACED** before the unit is put back into operation. Insulation loses its insulating value when wet, damaged, separated or torn.

Matt- or foil-faced insulation is installed in indoor equipment to provide a barrier between outside air conditions (surrounding ambient temperature and humidity) and the varying conditions inside the unit. If the insulation barrier is damaged (wet, ripped, torn or separated from the cabinet walls), the surrounding ambient air will affect the inside surface temperature of the cabinet. The temperature/humidity difference between the inside and outside of the cabinet can cause condensation on the inside or outside of the cabinet which leads to sheet metal corrosion and subsequently, component failure.

### REPAIRING DAMAGED INSULATION

Areas of condensation on the cabinet surface are an indication that the insulation is in need of repair.

If the insulation in need of repair is otherwise in good condition, the insulation should be cut in an X pattern, peeled open, glued with an appropriate all-purpose glue and placed back against the cabinet surface, being careful to not overly compress the insulation so the insulation can retain its original thickness. If such repair is not possible, replace the insulation. If using foil-faced insulation, any cut, tear, or separations in the insulation surface must be taped with a similar foil-faced tape.

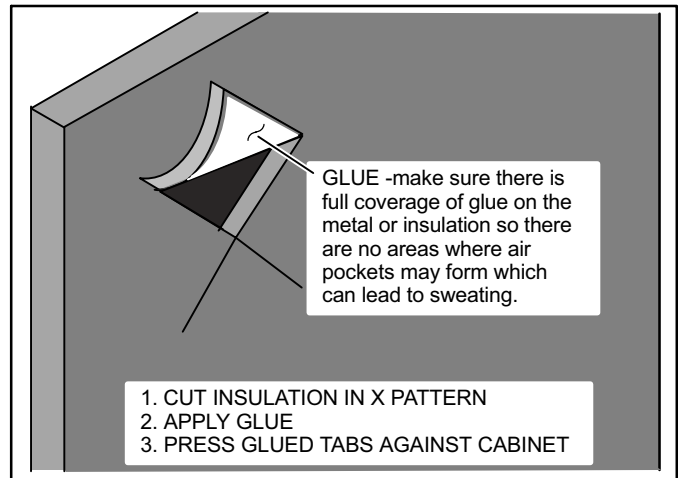

Figure 23. Repairing Insulation

**⚠ WARNING**  
**Electric Shock Hazard.**  
 Can cause injury or death.  
 Foil-faced insulation has conductive characteristics similar to metal. Be sure there are no electrical connections within a 1/2" of the insulation. If the foil-faced insulation comes in contact with electrical voltage, the foil could provide a path for current to pass through to the outer metal cabinet. While the current produced may not be enough to trip existing electrical safety devices (e.g. fuses or circuit breakers), the current can be enough to cause an electric shock hazard that could cause personal injury or death.

### Homeowner Maintenance

**⚠ IMPORTANT**  
 Do not operate system without a filter. A filter is required to protect the coil, blower, and internal parts from excessive dirt and dust. The filter is placed in the return duct by the installer.

- Inspect air filters at least once a month and replace or clean as required. Dirty filters are the most common cause of inadequate heating or cooling performance.
- Replace disposable filters. Cleanable filters can be cleaned by soaking in mild detergent and rinsing with cold water.
- Install new/clean filters with the arrows on the side pointing in the direction of airflow. Do not replace a cleanable (high velocity) filter with a disposable (low velocity) filter unless return air system is properly sized for it.
- If water is dripping from the secondary drain line, a problem exists which should be investigated and corrected. Contact a licensed professional service technician.

## Checkout Procedures

*NOTE - Refer to outdoor unit installation instructions for system start-up instructions and refrigerant charging instructions.*

### PRE-START-UP CHECKS

- Is the air handler properly and securely installed?
- If horizontally configured, is the unit sloped up to 1/4 inch toward drain lines?
- Will the unit be accessible for servicing?
- Has an auxiliary pan been provided under the unit with separate drain for units installed above a finished ceiling or in any installation where condensate overflow could cause damage?
- Have ALL unused drain pan ports been properly plugged?
- Has the condensate line been properly sized, run, trapped, pitched, and tested?
- Is the duct system correctly sized, run, sealed, and insulated?
- Have all cabinet openings and wiring been sealed?
- Is the indoor coil factory-installed expansion valve properly sized for the outdoor unit being used?
- Have all unused parts and packaging been disposed of?
- Is the filter clean, in place, and of adequate size?
- Is the wiring neat, correctly connected, and in accordance with the wiring diagram?

- Is the unit properly grounded and protected (fused)?
- Is the thermostat correctly wired and in a good location?
- Are all access panels in place and secure?

### CHECK BLOWER OPERATION

- Set thermostat to FAN ON.
- The indoor blower should come on.

### CHECK COOLING OPERATION

- Set thermostat to force a demand for cooling (approximately 5°F lower than the indoor ambient temperature).
- The outdoor unit should come on immediately and the indoor blower should start between 30 - 60 seconds later.
- Check the airflow from a register to confirm that the system is moving cooled air.
- Set the thermostat 5°F higher than the indoor temperature. The indoor blower and outdoor unit should cycle off.

### CHECK ELECTRIC HEATER (IF USED)

- Set thermostat to call for auxiliary heat (approximately 5°F above ambient temperature). The indoor blower and auxiliary heat should come on together. Allow a minimum of 3 minutes for all sequencers to cycle on.
- Set the thermostat so that it does not call for heat. Allow up to 5 minutes for all sequencers to cycle off.

Installing Contractor's Name \_\_\_\_\_  
 Installing Contractor's Phone \_\_\_\_\_  
 Job Address \_\_\_\_\_

Installing Date \_\_\_\_\_  
 Air Handler Model # \_\_\_\_\_

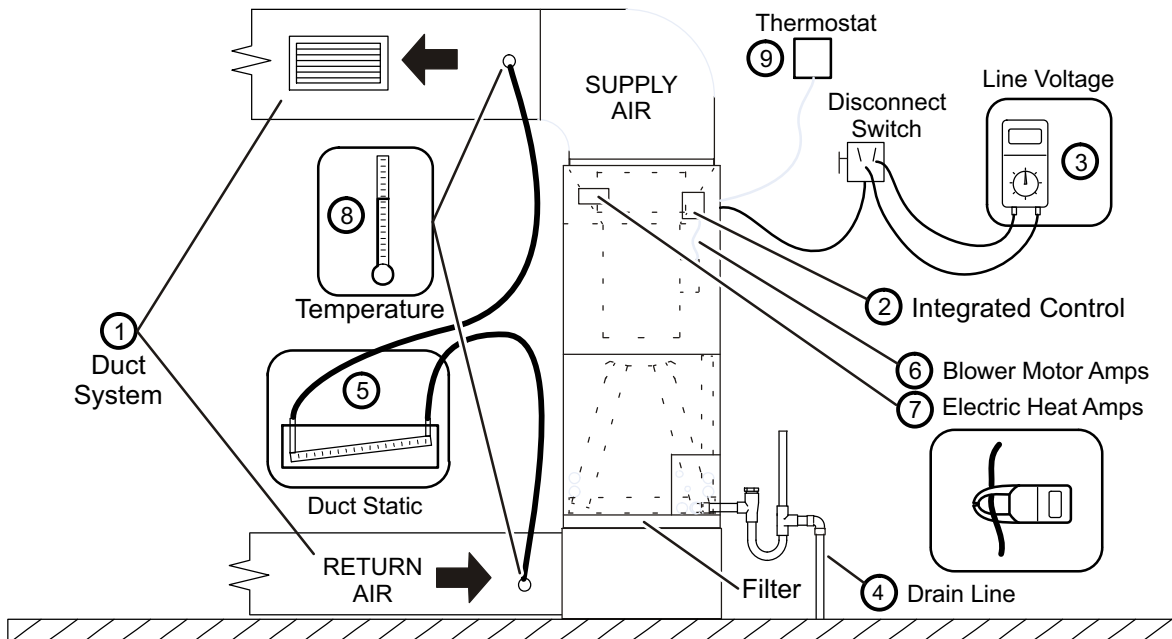

- |   |   |
|---|---|
| <p><b>① DUCT SYSTEM</b></p> <p>SUPPLY AIR DUCT</p> <p><input type="checkbox"/> Sealed</p> <p><input type="checkbox"/> Insulated (if necessary)</p> <p><input type="checkbox"/> Registers Open and Unobstructed</p> <p>RETURN AIR DUCT</p> <p><input type="checkbox"/> Sealed</p> <p><input type="checkbox"/> Filter Installed and Clean</p> <p><input type="checkbox"/> Registers Open and Unobstructed</p> <p><b>② INTEGRATED CONTROL</b></p> <p><input type="checkbox"/> Jumpers Configured Correctly (if applicable)</p> <p><input type="checkbox"/> Appropriate Links in Place (if applicable)</p> <p><b>③ VOLTAGE CHECK</b></p> <p><input type="checkbox"/> Supply Voltage _____</p> <p><input type="checkbox"/> Low Voltage _____</p> <p><input type="checkbox"/> Electrical Connections Tight</p> <p><b>④ DRAIN LINE</b></p> <p><input type="checkbox"/> Leak Free</p><br><p><input type="checkbox"/> Explained Operation of System to Homeowner</p> | <p><b>⑤ TOTAL EXTERNAL STATIC (dry coil)</b></p> <p style="text-align: right;">dry coil    wet coil</p> <p>Supply External Static _____</p> <p>Return External Static _____</p> <p>Total External Static = _____</p> <p><b>⑥ ELECTRIC HEAT AMPS</b> _____</p> <p><b>⑦ INDOOR BLOWER AMPS</b> _____</p> <p>INDOOR BLOWER CFM _____</p> <p><b>⑧ TEMPERATURE DROP (Cooling Mode)</b></p> <p>Return Duct Temperature _____</p> <p>Supply Duct Temperature - _____</p> <p>Temperature Drop = _____</p> <p><b>⑧ TEMPERATURE RISE (Heating Mode)</b></p> <p>Return Duct Temperature _____</p> <p>Supply Duct Temperature - _____</p> <p>Temperature Rise = _____</p> <p><b>⑨ THERMOSTAT</b></p> <p><input type="checkbox"/> Adjusted and Programmed</p> <p><input type="checkbox"/> Operation Explained to Owner</p> |
|---|---|

Technician's Name: \_\_\_\_\_ Date Start-Up & Performance Check Completed \_\_\_\_\_

**Figure 24. Start-Up and Performance Checklist (Upflow Configuration)**

