

## Downflow, Direct Vent (Sealed Combustion) Forced Air Gas and Oil Furnaces



# Installation Instructions/Owners Manual

Includes Warranty and Replacement Parts List

## Series MG, MM, MS and MB

For installation in:

1. Manufactured Homes
2. Recreational Vehicles, Park Models, Manufactured Buildings
3. Modular Homes/Buildings
4. Site Construction —Residential/Commercial

### FOR YOUR SAFETY

Do not store or use gasoline or other flammable vapors and liquids in the vicinity of this or any other appliance.

### ! WARNING:

Improper installation, adjustment, alteration, service or maintenance can cause injury or property damage. Refer to this manual. For assistance or additional information consult a qualified installer, service agency or the gas supplier.

### FOR YOUR SAFETY WHAT TO DO IF YOU SMELL GAS

- Do not try to light any appliance.
- Do not touch any electrical switch; do not use any phone in your building.
- Immediately call your gas supplier from a neighbor's phone. Follow the gas supplier's instructions.
- If you cannot reach your gas supplier, call the fire department.

### ! WARNING:

Should overheating occur, or the gas supply fail to shut off, shut off the manual gas valve to the appliance before shutting off the electrical supply.

### ! WARNING:

Do not use this appliance if any part has been submerged under water. Immediately call a qualified service technician to inspect the appliance and to replace any part of the control system and any gas control that has been submerged underwater.

Leave these instructions with the homeowner. Advise unit owner/user to follow the maintenance recommendations outlined. Have a qualified service technician periodically check all wiring connections and service unit as needed.

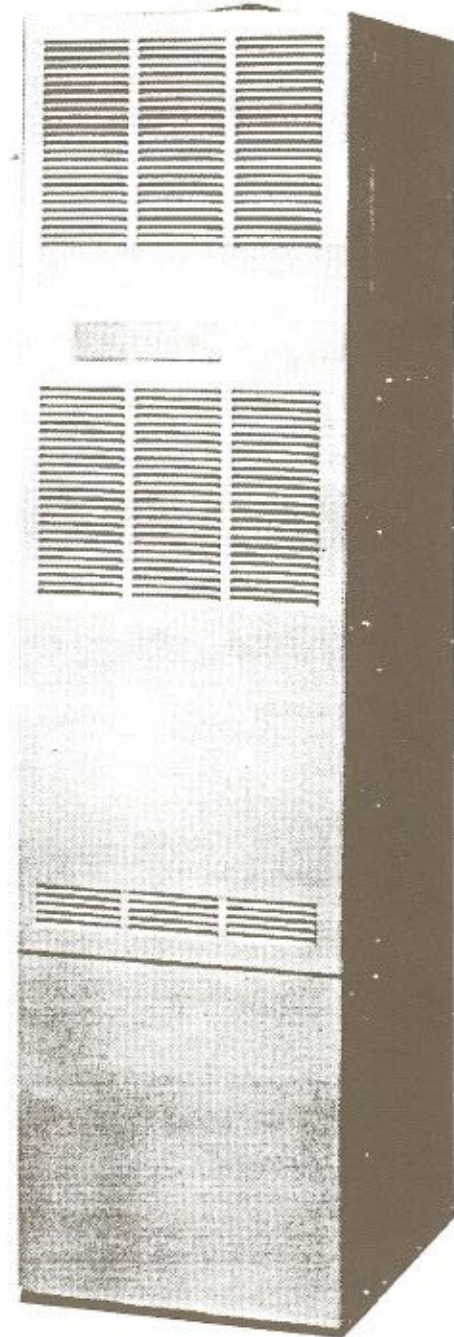

These instructions are primarily intended to assist qualified individuals experienced in the proper installation of heating and/or air conditioning appliances. Some local codes require licensed installation service personnel for this type of equipment. Read all instructions carefully before starting the installation.

## TABLE OF CONTENTS

WARRANTY .....	4
SPECIFICATIONS .....	5
OWNERS INFORMATION .....	6
MANUFACTURER WARRANTY, OWNER RESPONSIBILITY .....	7
INSTALLATION STANDARDS .....	7
UNIT LOCATION .....	8
MINIMUM CLEARANCES .....	8
RETURN AIR PROVISIONS .....	8
AIR DISTRIBUTION SYSTEMS .....	9
ROOF JACK SELECTION .....	10
DUCT CONNECTOR SELECTION .....	11
INSTALLATION .....	11
FLOOR OPENING AND FUEL LINE HOLE .....	11
CEILING AND ROOF OPENINGS .....	12
DUCT OPENINGS .....	12
FURNACE MOUNTING PLATE .....	12
DUCT CONNECTOR .....	12
FURNACE .....	13
ROOF JACK .....	13
INSTALLATION OF TRANSIT-MODE VENTING SYSTEM .....	14
ELECTRICAL WIRING .....	15
FUEL PIPING .....	16
LIGHTING AND FURNACE SHUT DOWN .....	17
STANDING PILOT (MGHA, MGHB, MGBB) .....	17
SEQUENCE OF OPERATION-STANDING PILOT .....	18
DIRECT IGNITION (MMHA, MMHB, MMBB, MBHA, MBBA) .....	19
SEQUENCE OF OPERATION-DIRECT IGNITION .....	19
INSTRUCTIONS-GAS GUN (MBHA, MBBA) .....	20
INSTRUCTIONS-OIL GUN (MSHA MSBA) .....	19
SEQUENCE OF OPERATION OIL GUN .....	19
SEQUENCE OF OPERATION GAS GUN .....	20
SERVICE GUIDE .....	22
BURNER ADJUSTMENT .....	22
GAS CONVERSION .....	22
TROUBLESHOOTING .....	23
MAINTENANCE .....	24
ACCESSORIES .....	25
WIRING DIAGRAMS .....	27
REPLACEMENT PARTS LIST (MG, MM) .....	36
REPLACEMENT PARTS LIST (MB, MS) .....	39

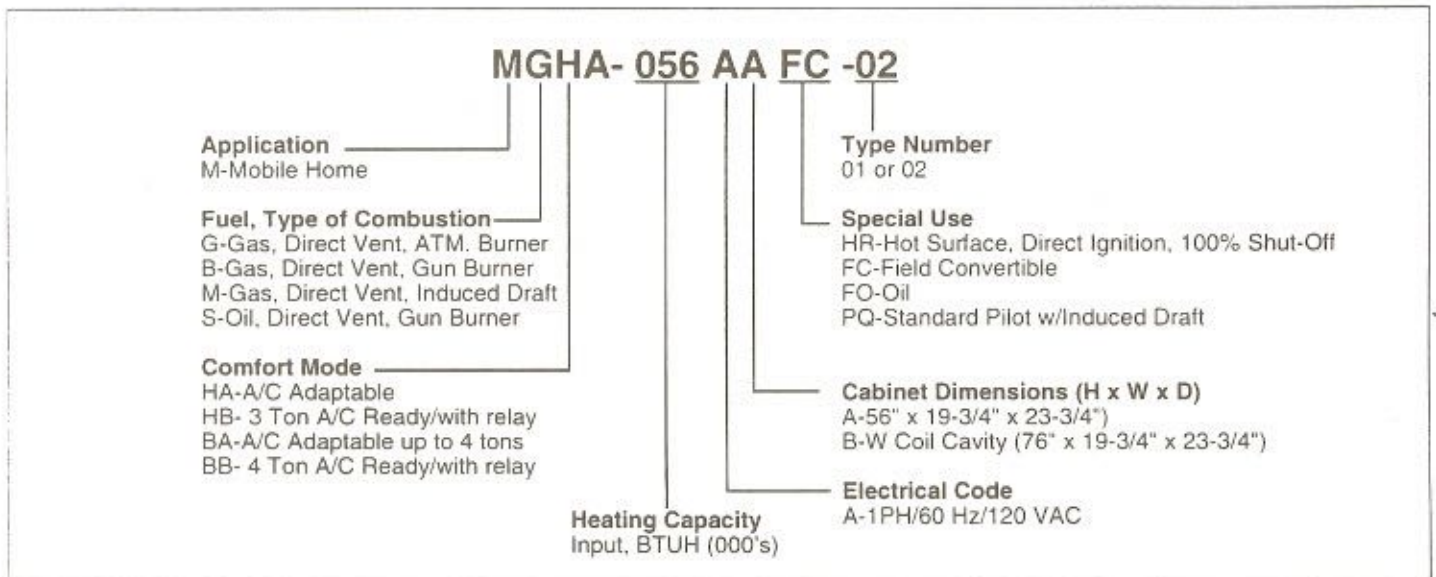

Table 2. Model Identification

# NORDYNE LIMITED WARRANTY

## Gas, Oil, Electrical Furnaces and Electrical Heat Modules installed in a Manufactured Home.

THIS WARRANTY IS EFFECTIVE ON FURNACES INSTALLED AFTER JANUARY 1, 1994

NORDYNE INC. warrants this appliance against failure due to defects in material and workmanship under normal use and service for the benefit of the original owner-user only, as set forth below. (Subsequent owners may obtain this warranty provided they contact NORDYNE INC. in writing to have the ownership transferred).

### LIMITATIONS:

This warranty applies only to NORDYNE INC. appliances installed and operated within the continental USA and Canada in accordance with NORDYNE INC. design specifications stated on the appliance data plate/label and instructions supplied with the appliance; and does not cover failure due to accident, misuse, abuse, faulty installation, or adjustments to appliance controls required to adapt the appliance operation to the structure size, geographic location or fuel supply.

### THIS WARRANTY DOES NOT COVER:

1. Converting the furnace from one fuel to another.
2. Adjusting the heat anticipator on the thermostat.
3. Any guarantee to the temperature difference between the inside and outside of the structure.
4. Normal maintenance, such as oil nozzle replacement, filter replacement, etc.

This warranty is void if the serial number that is affixed to the appliance has been removed, altered or defaced.

"This warranty is the only express warranty on this appliance and no other statement, representation or agreement by any person shall be valid or binding on NORDYNE INC. any implied warranties, including merchantability, are limited to the initial five year period of this warranty. NORDYNE INC. is not liable for any consequential or incidental changes caused by any defect in this appliance."

This warranty gives you specific legal rights and you may have other rights which vary from state to state. Some states do not allow limitations on how long an implied warranty lasts or on the exclusion or limitation of incidental or consequential damages, so the above limitation or exclusion may not apply to you.

### FIVE YEAR PARTS AND TWO YEAR LABOR COVERAGE:

If any part of this appliance fails due to defects in material or workmanship under normal use and service within five years from the date of the original purchase date of this appliance (or home in which the appliance was installed as new, original equipment), a NORDYNE INC. Distributor will supply a replacement part, if required, at no charge, to the nearest authorized service firm. Freight charges for the replacement part are the sole responsibility of the appliance owner.

In addition to providing the service firm with an in-warranty replacement part a NORDYNE INC. distributor will pay the service firm the labor charges based on NORDYNE INC.'s warranty labor rate program. The labor will be paid for work performed during the limited warranty period which is two years from the date of purchase of the appliance.

### CAUTION:

Use of a service firm not authorized or approved by NORDYNE INC. may result in service and/or parts charges in excess of NORDYNE INC.'s normal warranty allowance. Any such excess charges are the responsibility of the owner-user, and not payable by NORDYNE INC. Installation or parts or alteration to this appliance not compatible with NORDYNE INC.'s design and/or operation specifications which render the unit unsafe or adversely affect the unit operating characteristics will void this warranty.

IT IS THE SOLE RESPONSIBILITY OF THE OWNER/USER OF THE APPLIANCE TO SEE THAT THE APPLIANCE IS PROPERLY MAINTAINED AND SERVICED DURING THE LIFE OF THE APPLIANCE. FAILURE TO HAVE NORMAL SERVICE AND MAINTENANCE PERFORMED ON THE APPLIANCE MAY VOID THIS WARRANTY.

### HEAT EXCHANGER (GAS AND OIL FURNACES):

Heat exchangers which fail due to rust are excluded from this coverage if a self contained air conditioner was connected to the furnace duct without installing a proper close-off damper on the furnace. If the heat exchanger in this appliance fails due to a defect in material or workmanship after the expiration of the fifth year of coverage on the part, but within the sixth through tenth year of the part, NORDYNE INC. will provide a NORDYNE INC. Distributor a replacement heat exchanger at no charge which will be provided to an authorized service firm for installation into the original appliance. Freight charges for the heat exchanger are the responsibility of the owner/user of the appliance. Labor charges to replace the heat exchanger after the second year is the responsibility of the owner/user of the appliance.

### APPLIANCE TRADE-IN OPTION:

If a replacement heat exchanger is not available for this model furnace, NORDYNE INC. will not issue a refund for the furnace, but will issue a credit to a NORDYNE INC. distributor for the heat exchanger. The credit will be passed to the service firm and then to the user/owner of the appliance and be applied to the purchase of a new furnace.

### Replacement parts coverage:

Replacement parts installed under the terms of this warranty are warranted only for the remainder of the initial coverage of the defective parts replaced.

### To obtain warranty service and replacement parts:

1. Thoroughly read the appliance warranty information.
2. Make all service checks recommended in the homeowner's manual supplied with this appliance.
3. If the problem still persists, contact the service/dealer who installed the appliance, or
4. Contact the company from which you purchased the appliance for assistance, or the company who installed the furnace.
5. If further assistance is needed contact a NORDYNE INC. Distributor in your area (See enclosed list).
6. If, after following the above directions, you are still having difficulty, contact the NORDYNE INC. Technical Service Department In St. Louis, MO.

Technical Service Department  
NORDYNE INC.  
PO Box 46911  
St. Louis, MO 63146-6911  
314-878-6200

(Note: collect calls will not be accepted)

Buyer protection plans are available through your NORDYNE INC. Distributor. This plan provides you with additional years of service protection. The buyer protection plan must be purchased within 180 days from the date the furnace was installed. Contact a NORDYNE INC. Distributor in your area for more details. The homeowner packet supplied with this product has a list of NORDYNE INC. Distributors for your reference.

## NOTICE TO INSTALLER

Installer is advised to follow carefully all instructions and warnings in this manual to insure maximum performance, safety, and operating efficiency of these appliances. Improper installation may create hazardous conditions, and will void the appliance warranty.

### 1. SPECIFICATIONS

#### GENERAL DESCRIPTION

MG, MM, MS, and MB Series gas and oil furnaces are U.L. Listed and CSA certified direct vent (sealed combustion), downflow heating and appliances for manufactured (mobile) homes, recreational vehicles, and for use in residential/modular/commercial construction. The furnace must be located so that venting can be properly achieved.

"A" cabinet models may be installed with Optional Coil Cabinet Model #911969 for air conditioning.

"B" cabinet models are factory equipped with a built-in coil cavity.

DESCRIPTION	
<i>Standing Pilot A/C adaptable</i>	<i>Electric Ignition 3 ton Hot Surface/ A/C ready w/relay</i>
MGHA-056A (A,B)FC	MMHB-056A (A,B)HR
MGHA-070A (A,B)FC	MMHB-070A (A,B)HR
MGHA-077A (A,B)FC	MMHB-077A (A,B)HR
MGHA-090A (A,B)PQ	MMHB-090A (A,B)HR
<i>Standing Pilot 3 ton A/C adaptable w/relay</i>	<i>Electric Ignition 4 ton Hot Surface/ A/C ready w/relay</i>
MGHB-056A (A,B)FC	MMBB-056 AB HR
MGHB-070A (A,B)FC	MMBB-070 AB HR
MGHB-077A (A,B)FC	MMBB-077 AB HR
MGHB-090A (A,B)PQ	MMBB-090 AB HR
<i>Standing Pilot 4 ton A/C adaptable w/relay</i>	<i>Gas Gun A/C Adaptable</i>
MGBB-056 AB FC	MBHA-066A (A,B)FC
MGBB-070 AB FC	MBHA-086A (A,B)FC
MGBB-077 AB FC	<i>Gas Gun 4 ton A/C Adaptable</i>
MGBB-090 AB PQ	MBBA-066A (A,B)FC
	MBBA-086A (A,B)FC
<i>Electric Ignition Hot Surface/A/C adaptable</i>	<i>Oil Gun A/C Adaptable</i>
MMHA-056A (A,B)HR	MSHA-066A (A,B)FO
MMHA-070A (A,B)HR	MSHA-086A (A,B)FO
MMHA-077A (A,B)HR	<i>Oil Gun 4 ton A/C Adaptable</i>
MMHA-090A (A,B)HR	MSBA-066A (A,B)FO
	MSBA-086A (A,B)FO

Table 3.

Multi-speed, heating/cooling blowers 1/3 HP (p/n 901998) are factory-provided on MGBB, MMBB, MSBA, and MBBA models. Additionally, blower models 1/3 HP (p/n 901998) and 1/2 HP (p/n 901999) are certified for field installation in furnace models MG(H,B)(A,B); MM(H,B)(A,B); MS(H,B)(A,B); and MB(H,B)(A,B) when used in conjunction with 2-wire relay (p/n 901994); 5-wire relay (p/n 901995); and 2-wire relay used with A/C ready units (MG(H,B)B and MM(H,B)B (p/n 902649).

	GAS ATMOSPHERIC FURNACE MODEL NUMBER			
	MG(H,B)(A,B)- 056	MG(H,B)(A,B)- 070	MG(H,B)(A,B)- 077	MG(H,B)(A,B)- 090
MBtuh Input	56	70	77	90(87)*
MBtuh Output	45	57	62	72(70)*
Main Orifice #				
Nat.	29	23	20	17
L.P.	45	42	40	36
Pilot Orifice#				
Nat. & L.P.	0.014	0.014	0.014	0.014
Nom. Temp. Rise	55-85	55-85	55-85	55-85

\*CSA Input/Output

Table 4. Gas Atmospheric Furnaces

	GAS FORCED DRAFT, DIRECT IGNITION MODEL NUMBER			
	MM(H,B)(A,B)- 056	MM(H,B)(A,B)- 070	MM(H,B)(A,B)- 077	MM(H,B)(A,B)- 090
MBtuh Input	56	70	77	90(87)*
MBtuh Output	45	57	62	73(71)*
Main Orifice #				
Nat.	29	23	20	17
L.P.	45	42	40	36
Nom. Temp. Rise	55-85	55-85	55-85	55-85

\*CSA Input/Output

Table 5. Gas Forced Draft, Direct Ignition

	GAS AND OIL GUN FURNACES MODEL NUMBER			
	MS(H,B)(A,B)- 066	MB(H,B)(A,B)- 066	MS(H,B)(A,B)- 086	MB(H,B)(A,B)- 086
	POWER OIL	POWER GAS	POWER OIL	POWER GAS
MBtuh Input	66	66	86	86
MBtuh Output	57	56	72	71
Main Orifice #				
Nat.	-	26	-	17
L.P.	-	43	-	36
Burner Nozzle	50-80 B	-	65-80 B	-
GPH	0.5	-	0.65	-
Nom. Temp. Rise	55-85	55-85	55-85	55-85

Table 6. Gas A & Oil Gun Furnaces

For Tables 4, 5 & 6

Electrical Supply ..... 120 Volts, 60Hz, 1/PH  
Fuse or Breaker ..... 15 Amps  
Thermostat Circuit ..... 24 Volts, 60Hz, 15 VAC  
Nom. Anticipator Setting ..... 0.4  
Gas Valve Inlet ..... 1/2" NFPT

See the furnace label for listed optional air conditioning equipment.

## ABOUT YOUR CENTRAL FURNACE SYSTEM

The manufacturer of this furnace has been involved in the design of products for the manufactured home industry since the first mobile home or trailer was built.

NORDYNE originated the sealed combustion system, which separates the furnace combustion system from the living area of the home, now a standard for the manufactured home industry.

NORDYNE engineers developed the first central heating system and the first central air conditioner for manufactured homes.

NORDYNE is dedicated to bringing to its customers the finest heating and cooling comfort possible. NORDYNE constantly seeks to further refine its products to continuously provide exceptional comfort.

Follow the instructions in this booklet carefully and this appliance will provide many years of superior performance.

If you wish to cool your home automatically with a central air conditioning system investigate the excellent NORDYNE cooling systems available from your heating and cooling contractor. These systems are designed to work best with your NORDYNE furnace and have been carefully engineered to deliver optimum performance when mated with NORDYNE manufactured home furnaces.

NORDYNE also offers water heaters, fireplaces and ventilating systems specifically designed for manufactured housing applications. Check with your mobile home dealer, your heating and cooling contractor or your distributor for information. Write directly to the factory (PO Box 46911, St. Louis, MO 63146) if you are not able to locate a source for NORDYNE manufactured housing products in your area.

### 3. MANUFACTURER WARRANTY, OWNER'S RESPONSIBILITIES

It is the sole responsibility of the homeowner to make certain the gas furnace has been correctly set up and converted to the proper fuel (L.P. gas or Natural gas) and adjusted to operate properly. All gas furnaces are manufactured for Natural gas and must be field converted when using L.P. gas.

A warranty certificate with full details is included with these instructions. However, NORDYNE will not be responsible for any costs found necessary to correct problems due to improper setup, improper installation, furnace adjustments, improper operating procedure on the part of the user, etc.

Some specific examples of service calls which cannot be included in warranty payments are:

1. Converting the furnace to use another type of gas.
2. Repairing duct work in the home found to be faulty.
3. Correcting wiring problems in the electrical circuit supplying the furnace.
4. Resetting circuit breakers or other switches.
5. Correcting problems due to improper gas supply pressure to the furnace.
6. Providing instructional training on how to light and operate the furnace.
7. Furnace problems caused by installation of an air conditioner, heat pump or other air comfort devices.
8. Adding a Roof Jack extension because of unusual wind conditions.
9. Revising installation of the furnace flue assembly (Roof Jack).
10. Adjusting or calibrating of thermostat.

Carefully review these responsibilities with your manufactured housing dealer, service company or gas supplier so there will be no misunderstanding at a later time.

### CAUTION:

- **Never attempt to alter or modify this furnace or any of its components.**
- **Never attempt to repair damaged or inoperable components. Such action should cause unsafe operation, explosion and/or fire asphyxiation.**
- **If a malfunction has occurred, or if you feel that the furnace is not operating as it should, contact a qualified service agency or gas utility for assistance.**

### 4. INSTALLATION STANDARDS

Installer shall be familiar with and comply with all codes and regulations applicable to the installation of these heating appliances and related equipment. In lieu of local codes, the installation shall be in accordance with the current provisions of one or more of the following standards.

- a. Federal Manufactured Home Construction & Safety Standard (H.U.D. Title 24, Part 280)
- b. American National Standard (ANSI-119.2/NFPA-501C) for all recreational vehicle installations.
- c. American National Standard (ANSI-Z223.1/NFPA-54) and/or CAN/CGA B149 for all gas-fired furnace models.
- d. American National Standard (ANSI-Z95.1/NFPA-31) and/or CSA B139 for all oil-fired furnace models.
- e. American National Standard (ANSI-C1/NFPA-70) and/or CSA 22.1 Canadian Electric Code Part 1 for all electrical field wiring.
- f. Units have been investigated under standards UL 307A or 307B.

## 5. UNIT LOCATION

The furnace shall be appropriately located to the supply and return air distribution system. (See "AIR DISTRIBUTION", Page 9) Sides and back of the furnace may be enclosed by wall framing. (See "Minimum Clearances," Table 7, and Figures 3 through 5.)

The furnace installation is only intended for free air return through the furnace door louvers. DO NOT connect a ducted return air system directly to the furnace. Improper installation may create a hazard and damage equipment, as well as void all warranties.

Furnace may be installed on combustible flooring when using Series-458 Duct Connectors (see Table 10 and Figures 10-17).

## 6. MINIMUM CLEARANCES

This heating appliance must be installed with clearances not less than the minimums shown in Table 7. This heating appliance must be installed with ample clearance for easy access to the air filter, blower assembly, burner assembly, controls, and vent connections.

**Minimum furnace clearances to combustible materials shall be in accordance with the furnace rating plate. General clearances are as follows:**

- All installations: Back (0"), Sides (0"), Top (6"), Duct (0") and Roof Jack/Pipe (0").
- Alcove installations (see Figure 3); minimum 18" clearance at front of furnace shall be provided for future servicing. A removable access panel should be

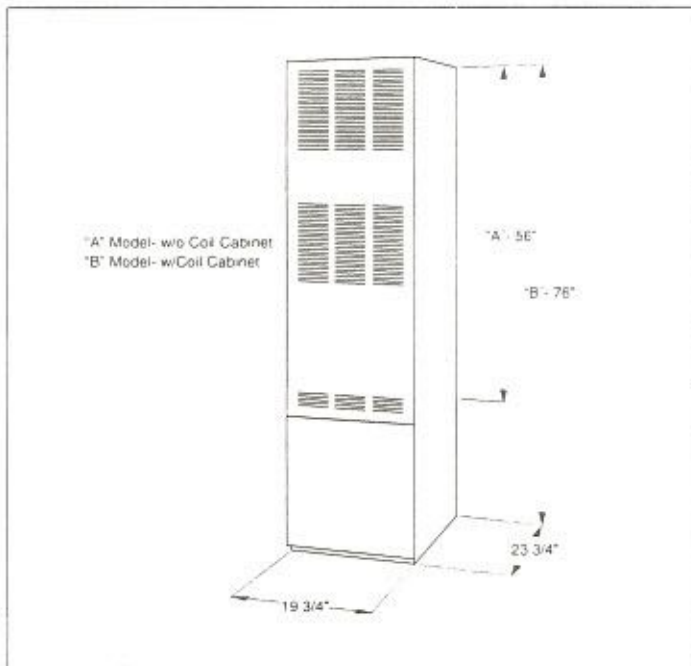

Figure 2. Overall Dimensions

ALL MODELS	CLOSET	ALCOVE
Front	6"	18"
Back	0"	0"
Sides	0"	0"
Roof Jack/Pipes	0"	0"
Top	6"	6"
Plenum Sides	0"	0"
Top and Sides of Duct	0"	0"
Bottom of Duct Within	0"	0"

Table 7. Minimum Clearances

installed between top of the furnace door frame and the ceiling.

- Closet installations must use a louvered door having a minimum free area of 235 sq. in. when located 6" from furnace (See Figure 4). For special clearance between 1" and 6", requirements are a louvered door with a minimum of 250 sq. in. free area, with the openings in the closet door directly in line with the louvered openings in the furnace door. A fully louvered closet door may be used (See Figure 5).

## ⚠ CAUTION:

**HAZARD OF ASPHYXIATION: Negative pressure inside the closet, with closet door closed and the furnace blower operating on high speed, shall be no more negative than minus 0.05 inch water column.**

## 7. RETURN AIR PROVISIONS

U.S.A. home manufactures shall comply with all of the following conditions to have U.L. acceptance of ceiling or in-floor return air systems for closet installed forced air heating appliances:

- Regardless of the location, the return air opening into the closet shall not be less than specified in the appliance's listing.
- Means shall be provided to prevent inadvertent closure by a flat object placed over the return air opening when it is located in the floor of the closet (versus the vertical front or side wall).
- The cross-sectional area of the return duct system leading into the closet, when located in the floor or ceiling shall not be less than 250 square inches.
- The total free area of openings in the floor or ceiling registers serving the return air duct system must be at least 352 sq.in. At least one register should be located where it is not likely to be covered by carpeting, boxes and other objects.

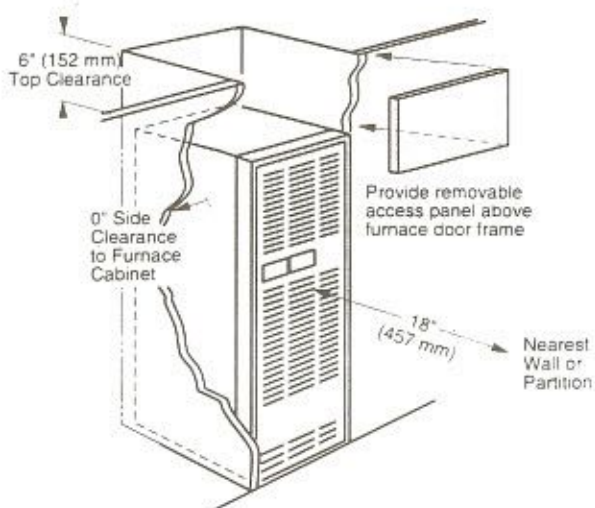

Figure 3. Alcove Installation

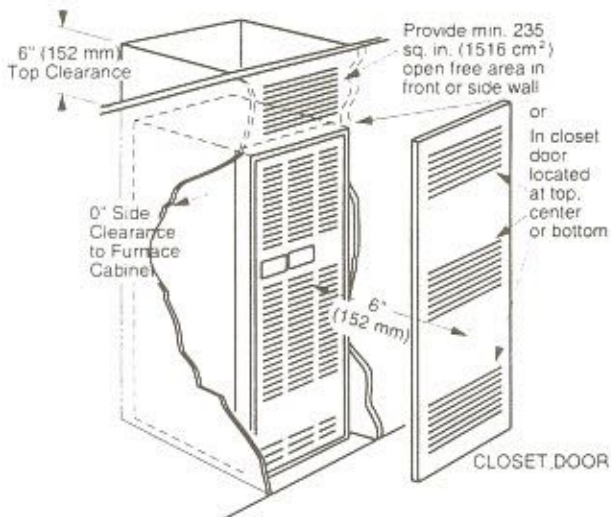

Figure 4. Closet Installation

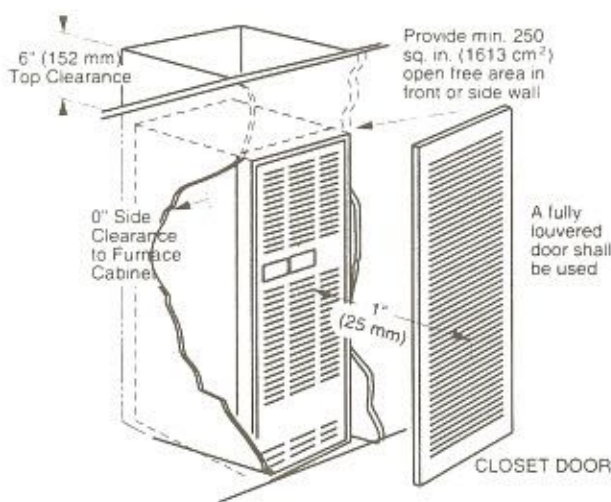

Figure 5. Special 1" Clearance

- e. Materials located in the return duct system have a flame spread classification of 200 or less.
- f. Noncombustible pans having 1" upturned flanges are located beneath openings in a floor duct system.
- g. Wiring materials located in the return duct system shall conform to Articles 300-22 of the National Electrical Code (ANSI C1/NFPA-70).
- h. Gas piping is not run in or through the return duct system.
- i. Test the negative pressure in the closet with the air-circulating fan operating at high speed and the closet closed. The negative pressure is to be no more negative than minus 0.05 inch water column.
- j. For floor return systems, the manufactured home manufacturer shall affix a prominent marking on or near the appliance where it can be easily read when the closet door is open. The marketing shall read:

**! CAUTION:**

**HAZARD OF ASPHYXIATION: Do not cover or restrict return air opening.**

**8. AIR DISTRIBUTION SYSTEMS**

For proper air distribution, the supply duct system must be designed so that the static pressure measured external to the furnace does not exceed the listed static pressure rating shown on the furnace rating plate.

Three typical distribution systems are illustrated in Figure 6.

Location, size, and number of registers should be selected on the basis of best air distribution and floor plan of the home.

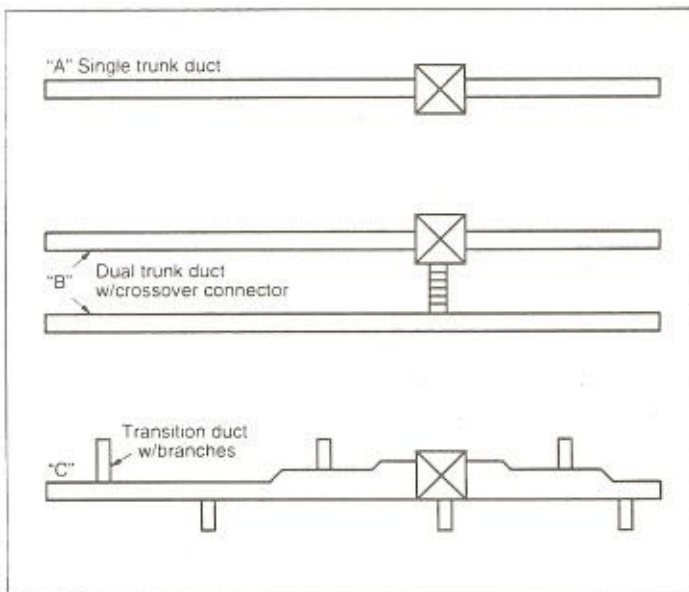

Figure 6. Typical Supply Duct System

## 9. ROOF JACK SELECTION

Note: Install only Roof Jack Assemblies listed in Table 8 on this heating appliance.

- Determine depth of ceiling cavity from center of roof opening to center of ceiling opening. (See Dimension "A" in Figure 7.)
- Determine ceiling height and subtract height of furnace. (See Dimensions "B" in Figure 7.)
- Add dimensions A + B (and X from Table 9 and Figure 8 if slant deck flashing is used). The total length of (A + B + X) will be within the minimum and maximum range of one of the Roof Jacks listed in Table 8.

### APPLICATION NOTES:

- FO, SO, SOT and FOT Series Roof Jacks with a 5" diameter inner vent pipe may be used with all models of MG, MM, MS, and MB Series gas and oil furnaces.
- F=Flat, Flashing; Adjusts from 0/12 to at least 1/12 roof slope.
- S=Slant Flashing for 2.5/12 Slope; adjusts 1/12 to 4/12 roof slope.

### ROOF JACK EXTENSION

Under some circumstances it may be desirable to raise the Roof Jack by using a furnace Roof jack extension (external extension p/n 901937, internal extension p/n 901935). An extension or high wind series roof jack may help to solve a pilot outage caused by unusual wind effects because of geographical features such as hills, trees, tall buildings, etc.

The extension is available as an optional accessory and may be purchased through your NORDYNE distributor.

MODEL NUMBER	APPROX. ADJ. LENGTHS* BELOW FLASHING
FO1323 -5	13" - 23"
FO2343 -5	23" - 43"
SO1835 -5	18" - 35"
SO2447 -5	24" - 47"
SO3263 -5	32" - 63"
SO4895 -5	48" - 95"
SOT2442 -5	24" - 42"
SOT2745 -5	27" - 45"
SOT4581 -5	45" - 81"
FOT2846 -5	28" - 46"

S	O	T	27	45	-5
S= SLANT FLASHING	O= TYPE: STANDARD	T= TRANSIT MODE TYPE	MIN. ADJ LENGTH	MAX. ADJ LENGTH	5 = 5" FLUE DIA.
F= FLAT FLASHING	H= HIGH WIND				

Table 8. Roof Jack Assemblies

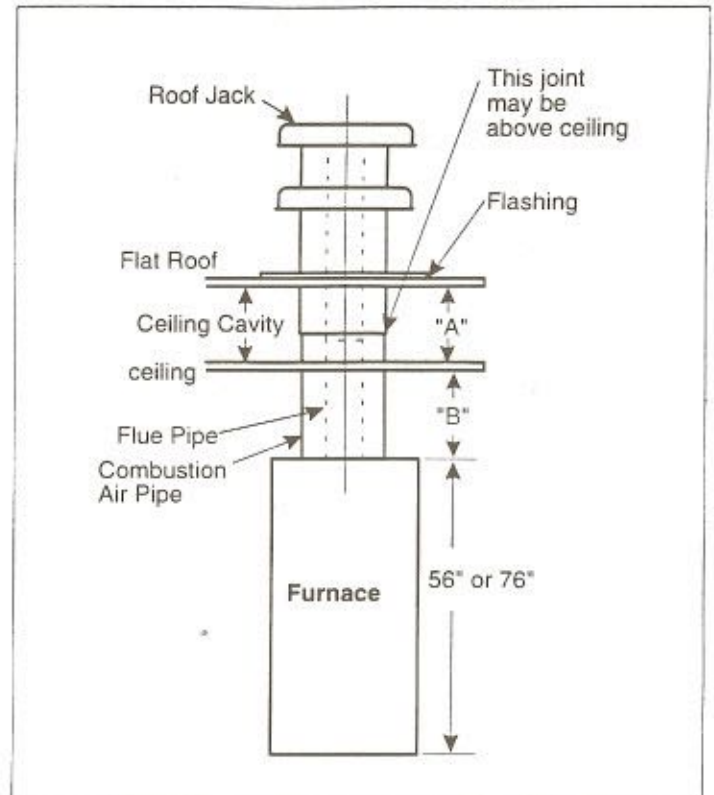

Figure 7. Roof Jack Assemblies

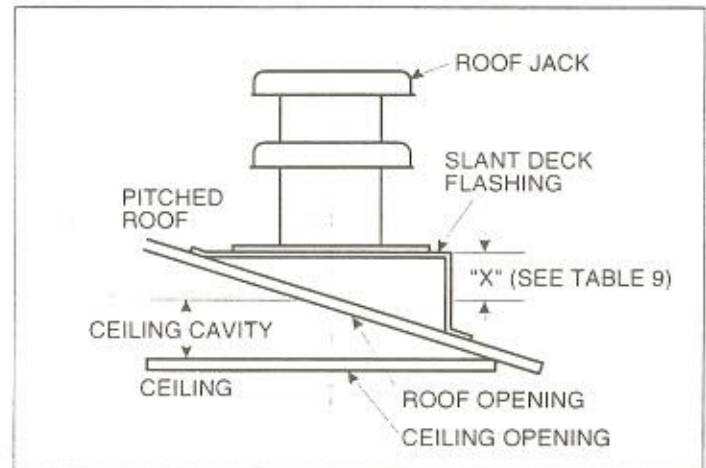

Figure 8.

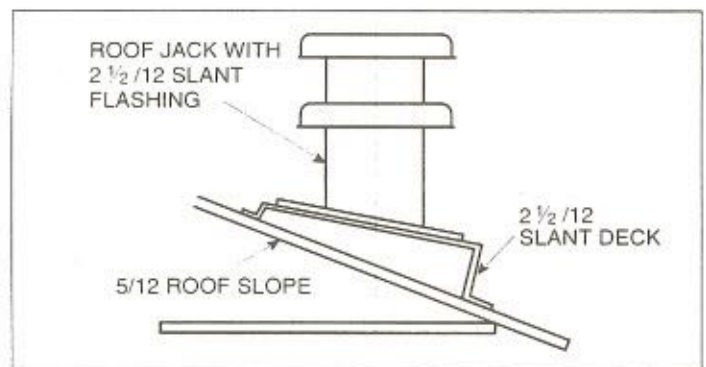

Figure 9.



IF PITCH IS:	FLASHING NO.	"X" FACTOR IS:
2" in 12" (51mm/304mm)	901942	2 1/8" (54MM)
2 1/2" in 12" (64mm/304mm)	901941	2 1/2" (64MM)
3" in 12" (76mm/304mm)	901940	2 7/8" (73MM)
3 1/2" in 12" (89mm/304mm)	901939	3 1/4" (83MM)
4" in 12" (102mm/304mm)	901938	3 5/8" (92MM)
5" in 12" (127mm/304mm)	Use 901941 with flue having slant flashing. See Fig. 9	2 1/2" (64MM)

Table 9. Optional Slant Deck Flashings

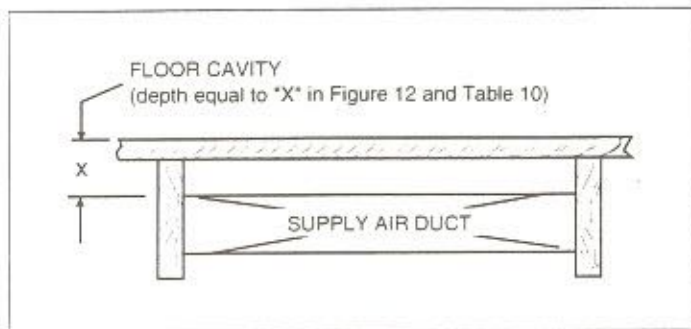

Figure 10.

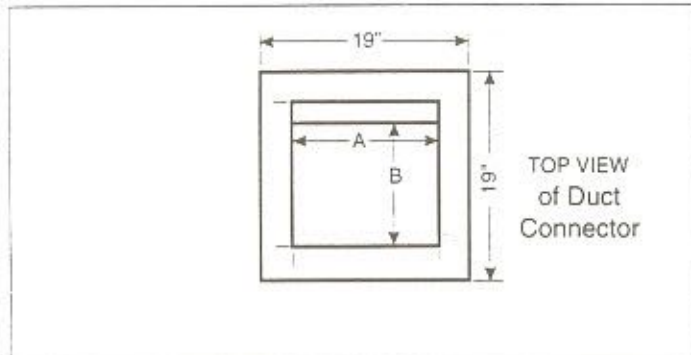

Figure 11.

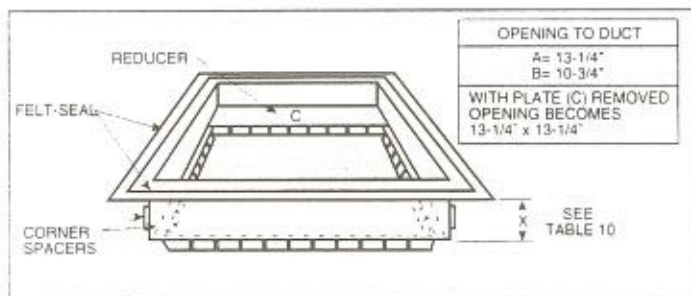

Figure 12.

If "X" (Floor cavity) is:	Use Duct Connector Model	Order Number
7/8" (22mm)	458901	901987
2" (51mm)	458902	901988
4 1/4" (108mm)	458903	901989
6 1/4" (159mm)	458904	901990
8 1/4" (210mm)	458905	901991
10 1/4" (260mm)	458906	901992
12 1/4" (311mm)	458907	901993

Table 10. Duct Connectors

## 10. DUCT CONNECTOR SELECTION

- Determine depth of floor cavity from surface of floor to top of supply air duct (See Figure 10).
- Select appropriate model from Table 10 which matches X-dimension of the floor cavity. To maximize air delivery, remove reducer "C" (see Figure 12) to obtain the largest open area that will fit the duct/floor construction.

## 11. INSTALLATION

Required floor, ceiling, and roof cutout openings must be carefully located to avoid misalignment of the furnace and Roof Jack (see Figures 13 & 14). Installation procedures are suggested for typical furnace installations and need not be followed in the exact listed sequence.

### ! IMPORTANT:

Refer to the installation instructions provided with optional air conditioning packages when installing furnaces with optional cooling coil cabinet or with optional C\*\*\*-series evaporators.

### CUT OUT FLOOR OPENING & FUEL LINE HOLE

- Determine center of closet or alcove (Figure 13).
- Locate center of the floor opening, measured 10" from the rear wall, and mark cutout measuring approximately 14-1/2" by 14-1/2" for model duct connector used (refer to Figures 11 & 12).
- Locate center of fuel line hole, measured 23-1/4" from the rear wall and 6-5/8" to the left of center of the floor cutout (See Figure 13) or 5-1/4" to the left of center of the floor cutout, or for entry through right-side of furnace measured 9" to the right of center of the floor cutout.
- Cut out floor opening and one fuel line hole.

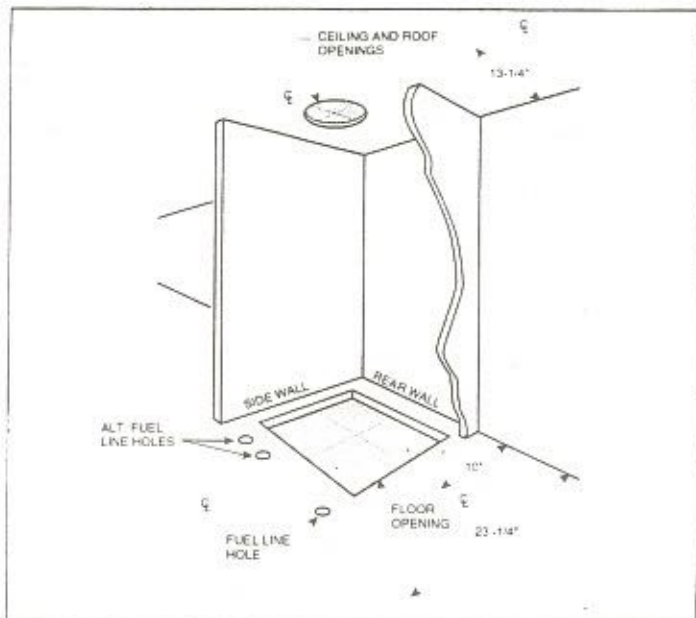

Figure 13. Closet or Alcove

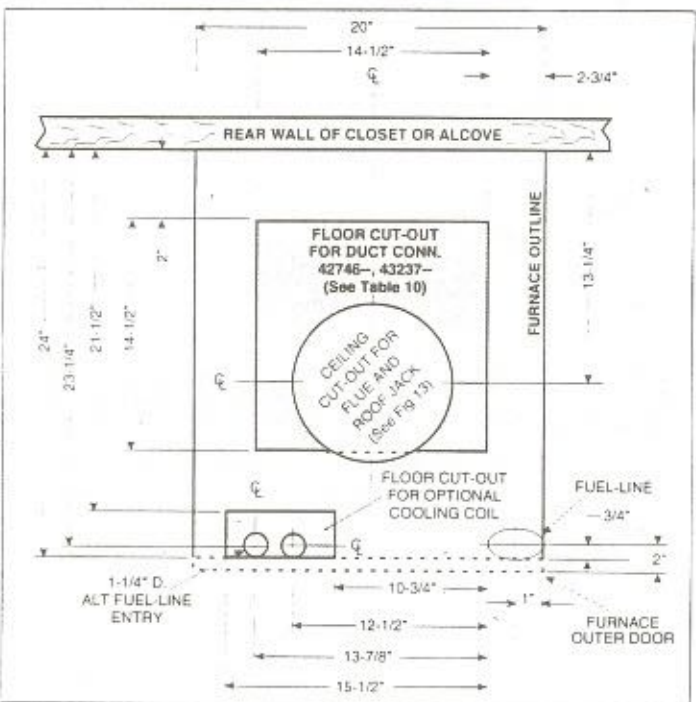

Figure 14. Cut-Out Locations

#### CUT OUT CEILING AND ROOF OPENINGS

- Locate center of Roof Jack opening, measured 13 5/8" from the rear wall of closet or alcove along the center line of furnace and floor opening. (See Figure 14)
- Cut ceiling and roof holes as follows:  
Ceiling Hole = 8-3/4" (222mm) diameter  
Roof Hole = 9-3/8" (238mm) diameter

#### CUT DUCT OPENING

- Place duct connector through the floor opening with bottom tabs resting on top of the supply air duct.

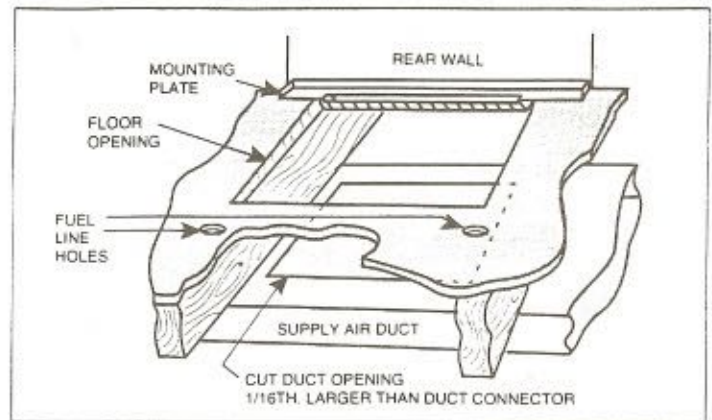

Figure 15. Mounting Plate

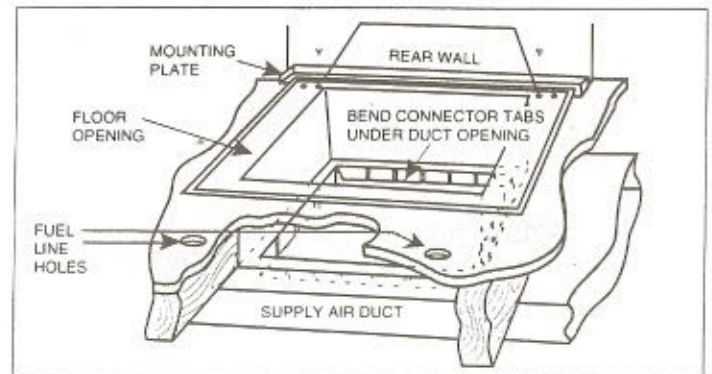

Figure 16. Duct Connector

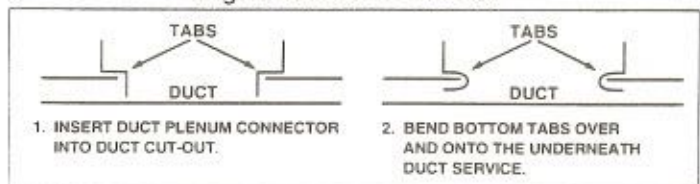

Figure 17. Installation of Duct Connector

- Center duct connector and push back against rear edge of floor opening.
- Mark cutout location (tab area) and remove duct connector.
- Cut out duct opening 1/4" larger than area marked.

#### INSTALL FURNACE MOUNTING PLATE

- Place mounting plate (supplied within duct connector) at rear of the floor opening (See Figure 16).

#### INSTALL DUCT CONNECTOR

- Place duct connector through the floor opening with bottom tabs extending through the duct opening. (See Figure 16)
- Secure duct connector and mounting plate with two (2) flathead screws or nails at dimpled mounting locations.
- Bend bottom tabs under and up tightly against the supply air duct (See Figure 17).

NOTE: The duct connector is designed for use on ducts 12" in width. When using the connector on 12" wide ducts, there may be insufficient clearance to bend the tabs on two sides

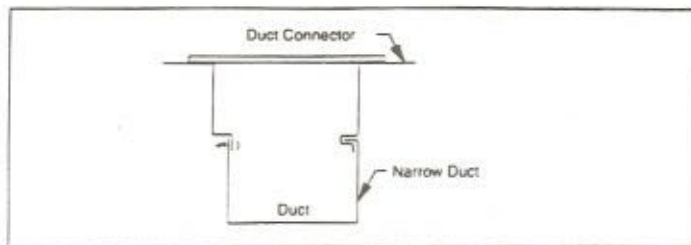

Figure 18.

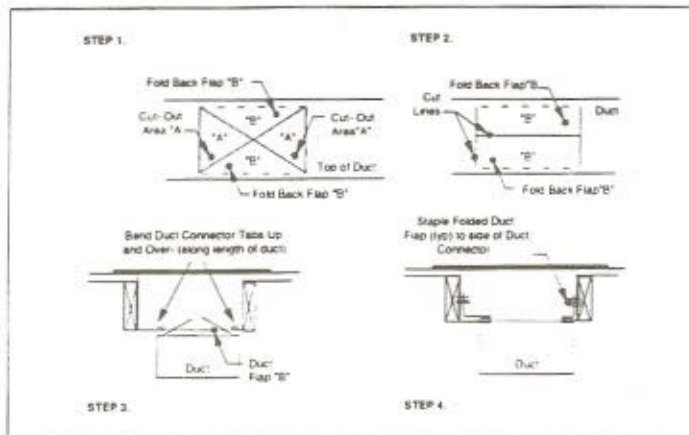

Figure 19.

of the duct connector. In such cases the tabs may be attached to the sides of the duct by using sheet metal screws or other suitable fasteners. (See Figure 18).

If tape is used to provide a better seal, it should be approved by applicable national or local codes.

#### ALTERNATE ATTACHMENT METHODS

This procedure may also be used to install a furnace duct connector to narrow metal ductwork where insufficient clearance prevents bending of the duct connector tabs at the side(s) of the duct. (See Figure 19).

1. Score and cut the top of the metal duct as indicated in Step 1 or Step 2. With Step 1 choice, also cut out the metal from the shaded area "A".
2. Fold the duct flap "B" up. (See Step 3).
3. At the front-to-back of duct run (Area "A"), bend the duct tabs and secure them directly to the duct.
4. At Area "B", bend the duct tabs up and back over, around the duct connector. (See Step 3).
5. Fold/form the duct flap against the side of the duct connector and attach as shown. (See Step 4). Use three (3) staples (minimum) on each duct flap OR, if a 2X block/joist is not provided, use two (2) sheet metal screws (minimum) on each duct flap.
6. Tape the duct flap edges with an approved tape for a leak-free joint.

#### INSTALL FURNACE

- a. Remove furnace outer door(s) and bottom fuel line knockout.
- b. Place furnace onto duct connector and center with floor opening.

- c. Slide back onto mounting plate until snug. (Bottom rear slots on furnace should engage with mounting plate tabs.)
- d. Secure front with one (1) screw at each corner (See Figures 20 or 21).

NOTE: Additional fasteners may be used at rear, sides or through door frame, as desired, to secure furnace to closet or alcove framing.

#### INSTALL ROOF JACK

Apply Caulking to Roof Flashing. Apply caulking compound on underside of roof flashing to form a continuous strip at least 3/8" wide (see Figure 22) around the underside of the perimeter of the flashing. Connect Roof Jack Assembly to the furnace. Insert telescoping Roof Jack Assembly through the opening cut on the roof. Connect flue pipe to flue collar of furnace. Connect combustion air pipe to furnace collar with sheet metal screw (See Figure 23). It is recommended that the connection of the combustion air pipe to the furnace be made before the flashing is secured to the roof to maintain alignment of roof jack and furnace connections.

NOTE: For replacement furnaces, be sure the inner flue pipe connects over the furnace vent collar. **DO NOT use a smaller diameter inner flue pipe which could slide inside the furnace vent collar and restrict the flow of furnace flue products.**

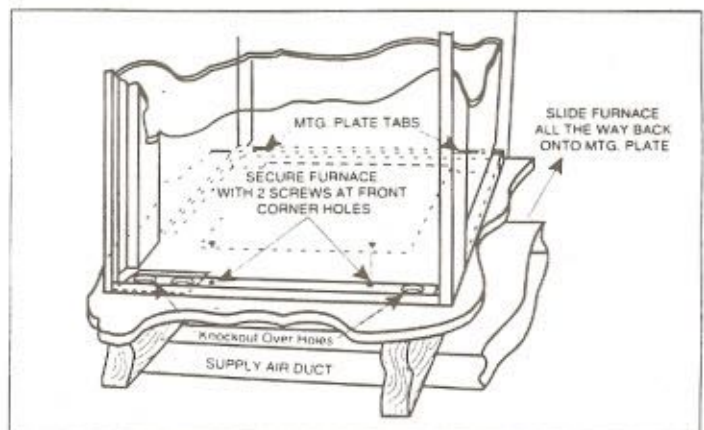

Figure 20. "A" & "B" Cabinet Furnaces

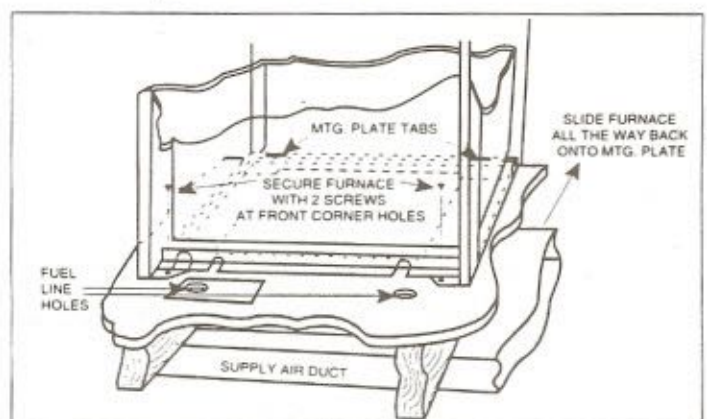

Figure 21. "A" Cabinet Furnace on 911969 Coil Cabinet

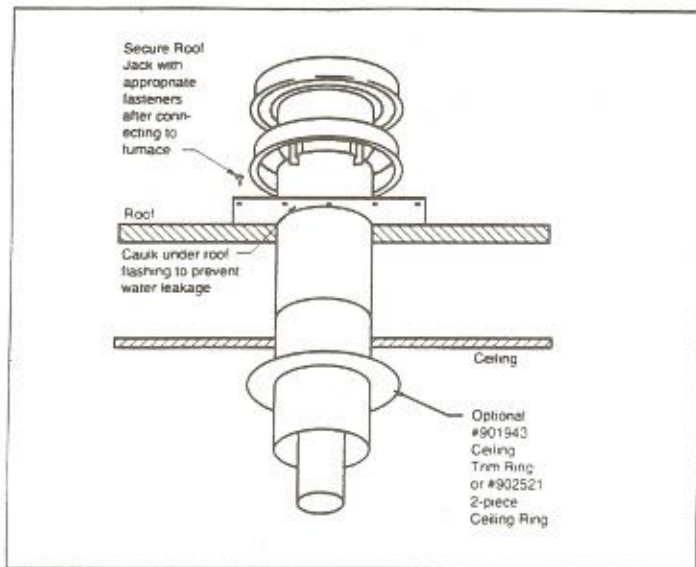

Figure 22. Flat Roof

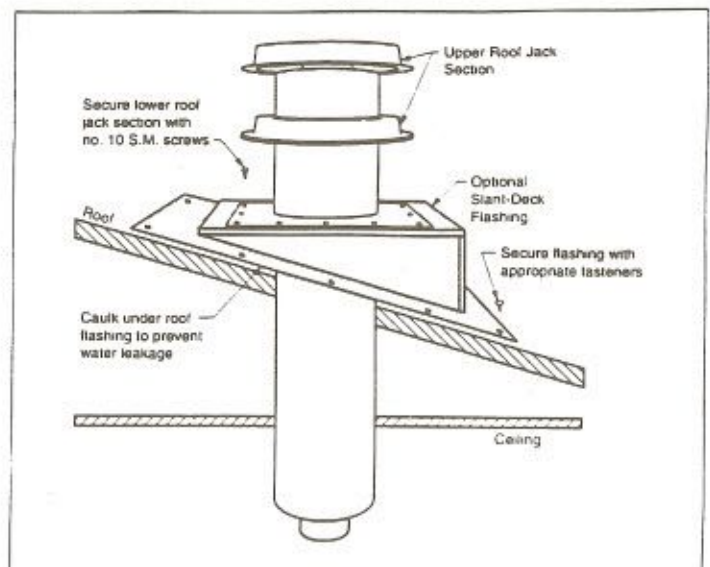

Figure 24. Pitched Roof

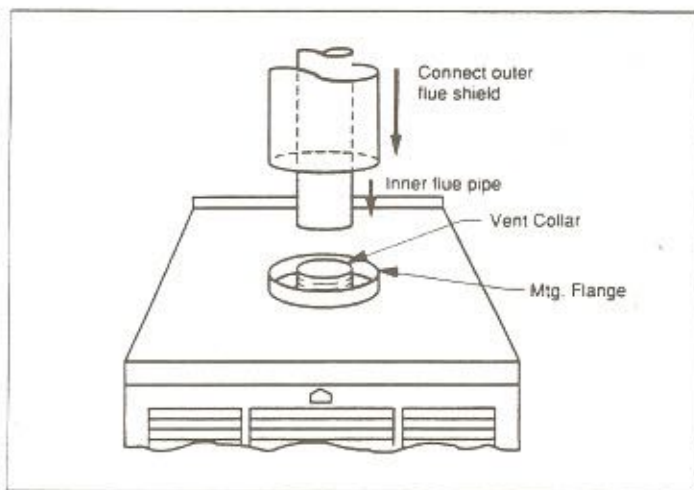

Figure 23.

**Attach Roof Flashing:** If necessary, shift roof flashing slightly in the roof opening so that assembly is in good alignment with furnace. Press down firmly over caulking on roof flashing to make the seal with roof water tight. Secure flashing with appropriate fasteners. As an added protection against leaks, coat the flashing plate and fasteners with approved roofing compound.

If flashing mounted on 12 degree angle is used it may be necessary to adjust the angle to match the roof pitch; (1/12 - 4/12 maximum).

### ⚠ WARNING:

Failure to properly secure the flue pipe to the furnace may result in fire, explosion or asphyxiation when operating the furnace.

## 12. INSTALLATION OF TRANSIT-MODE VENTING SYSTEM

### MANUFACTURED HOME FACTORY

- Furnace to be installed per furnace installation manual.
- Roof Jack to be selected from Table 8 of these instructions.
- Roof Jack (less upper Roof Jack crown), with weather cap to be installed as described under **Install Roof Jack**.
- Upper Roof Jack crown to be stored in a prominent location inside manufactured home until on-site installation.
- The four warning tags supplied must be installed as follows:
  - To weather cap
  - To fuel line connection point (Gas) or furnace burner (Oil)
  - To furnace flame observation door (Gas or Oil)
  - To furnace wall thermostat

### MANUFACTURED HOME SITE

- Transit-mode weather cap to be removed and upper Roof Jack crown installed (See Figure 25).
- Place upper Roof Jack (crown) on to the flue pipe assembly (See Figure 25). Be sure inside flue pipe attaches over inner flue pipe. Be sure outer Roof Jack pipe fits over outer pipe. Secure in place using three (3), #10, 1/2" sheet metal screws supplied.
- Venting system warning tags to be removed and discarded.

### ⚠ WARNING:

Any attempt to operate furnace before replacing transit-mode weather cap with upper roof jack section may result in hazard of fire, explosion or asphyxiation.

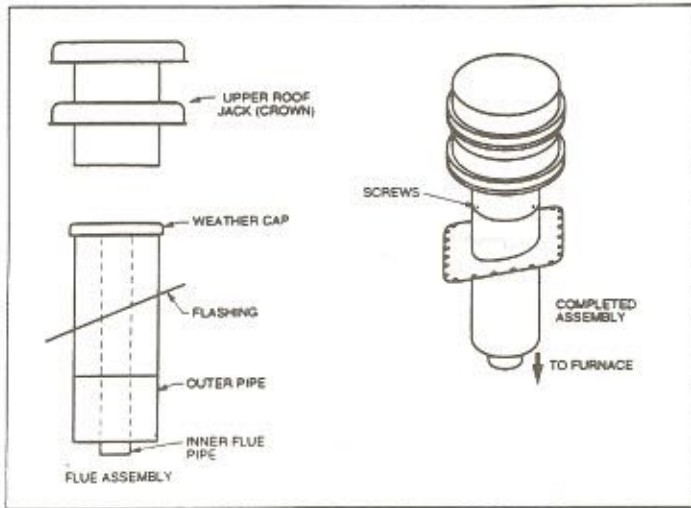

Figure 25.

### 13. ELECTRICAL WIRING

Refer to these installation instructions for individual wiring diagrams.

#### ELECTRICAL BRANCH SUPPLY CIRCUITS.

Route all electrical wiring to the left side of the furnace. For installation of "A" Cabinet furnaces, allow sufficient slack in the wiring if an optional cooling coil cabinet is added at a later time. *Use of copper conductors is recommended.*

Power supply circuit to the furnace must be installed and grounded in accordance with the National Electrical code (ANSI-C1/NFPA-70), or Canadian Electric Code Part 1 (CSA 22-1) and all local codes having jurisdiction.

#### CONNECT POWER SUPPLY WIRES

- Remove the furnace control panel cover.
- Insert 115 volt wires through the strain relief on the left side of the furnace junction box (see Figure 26).
- Connect the "hot" wire to the BLACK pigtail lead, and the "neutral" wire to the WHITE pigtail lead. Secure all connections with suitable wire nuts and wrap with electrical tape.
- Connect the "ground" wire to the grounding screw.
- Reinstall the control panel cover and secure with the original mounting screws.

#### CONNECT THERMOSTAT WIRES

- Insert 24 volt wires through the plastic grommet just above the control panel.
- Connect the thermostat wires to the furnace low voltage pigtails (see Figures 26 & 27).
- Connect low-voltage circuit to the wall thermostat.

NOTE: The thermostat should be installed 4 to 5 feet above the floor on an inside wall which is relatively free from direct sources of heat or cold drafts. The nominal anticipator setting is 0.4. (Refer to the thermostat literature for additional information.)

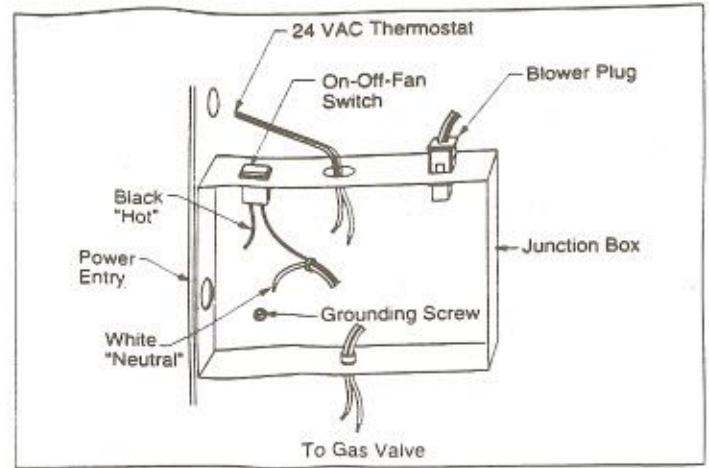

Figure 26. Control Panel (All Models)

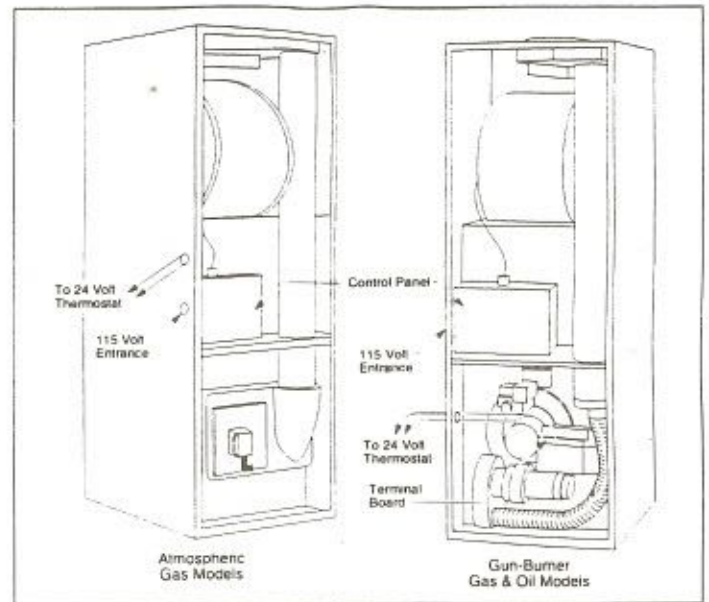

Figure 27. Thermostat Connections

Five-conductor thermostat wire is recommended for 24 volt low-voltage circuit (2-wire is required for furnace only; 5-wire for heating and optional cooling systems).

T*STAT Wire Gauge	Recommended T*STAT Wire Length (Unit to T*STAT)	
	2-Wire (Heating)	5-Wire (Heating/Cooling)
24	55	25
22	90	45
20	140	70
18	225	110

Once the furnace is installed check the thermostat anticipator against the nominal setting of 0.4:

- Connect the milliamp meter in series with one of the gas valve's low voltage terminals.
- Energize the gas valve.
- Read the value of the milliamps.
- Adjust the heat anticipator of the thermostat to the value read on the milliamp meter.

If the heat anticipator is set too high the furnace may delay in coming on.

If the heat anticipator is set too low the furnace may cycle frequently and not provide comfort to the homeowner.

#### CHECK BLOWER CONNECTION

- For intermittent (thermostatically controlled) blower operation, place the On-Off-Fan switch in the "ON" position (see Figure 26).
- For continuous (independent) blower operation, place the On-Off-Fan switch in the "FAN" position.
- To turn "off" electrical power to the furnace, place the On-Off-Fan switch in the "Off" position.

### 14. FUEL PIPING

Sizing and installation of fuel lines must be in accordance with federal, state and local regulations. All piping shall be black iron pipe, or equivalently sized steel tubing. Internally tinned copper tubing may be used for gas supply systems.

Fuel line installations other than typical installations shown in Figures 28 and 29 must comply with the fuel piping provisions stated in the Federal Mobile Home Standard (H.U.D. TITLE 24, PART 280) and the National Fuel Gas Code (ANSI-Z223.1/NFPA-54).

- Optional fuel inlet lines are available for all gas furnace models to permit the addition of a 1/2" F.P.T. shut-off valve above the floor.

NOTE: Shut-off valve must be designed and listed for use with liquid petroleum (L.P. gas).

The gas supply to your home will either be Natural Gas or L.P. (bottle gas). Your furnace is factory equipped to operate on Natural Gas. If your gas supply is L.P. (bottle gas), you must

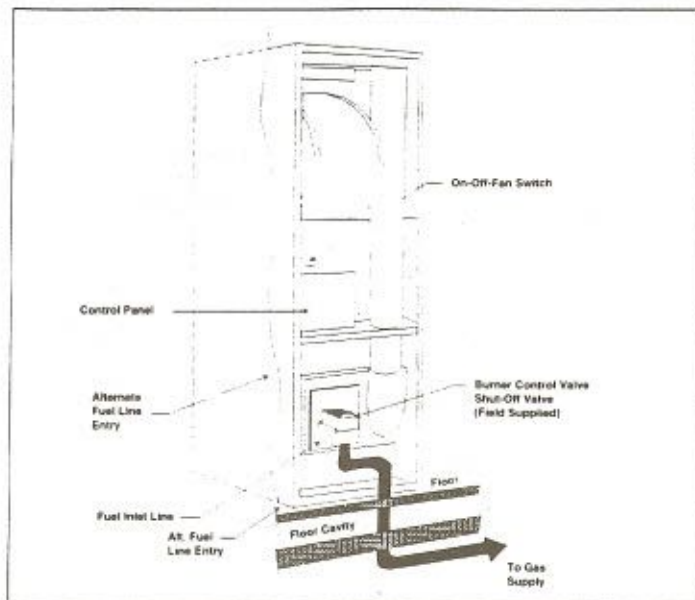

Figure 28. Typical Gas Piping

contact a qualified serviceman or gas supplier to convert the furnace. The necessary instructions for the gas conversion are found on the lighting instruction label attached to the furnace, and Page 17.

**⚠ CAUTION:**  
**The furnace must be converted by a qualified technician. Improper conversion can cause unsafe operation, explosion, fire and/or asphyxiation.**

For natural gas operation, the furnace is designed for 7" W.C. inlet pressure. Pressure is reduced to 3-1/2" W.C. by the pressure regulator in the gas valve.

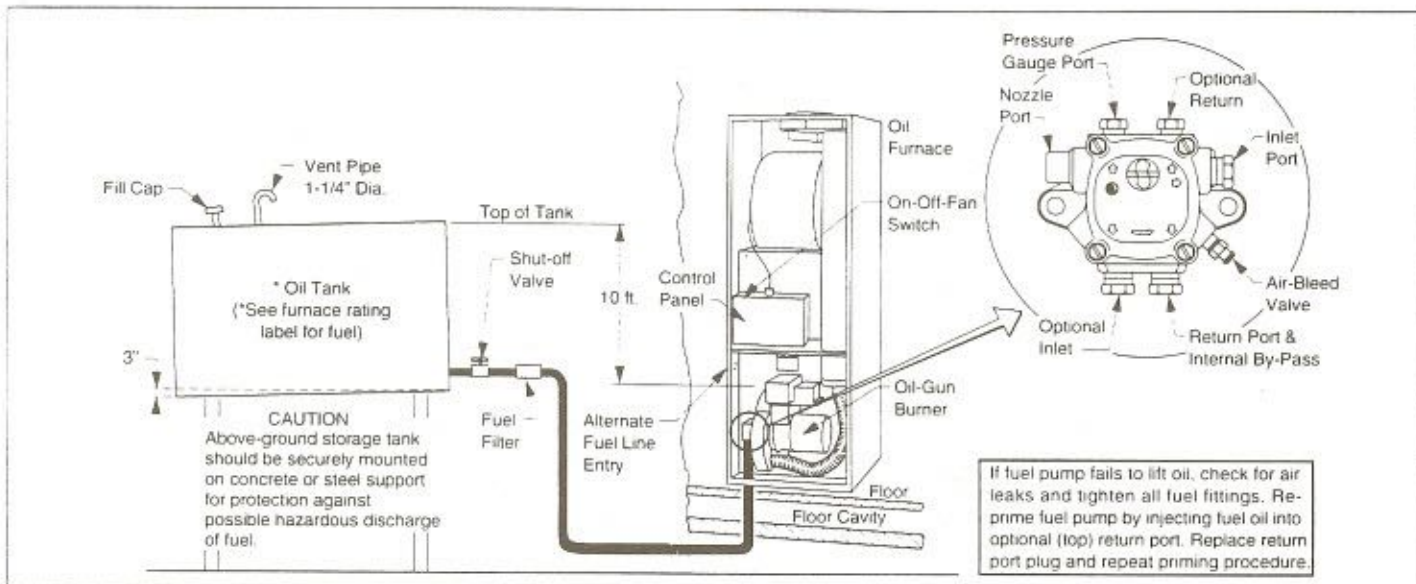

Figure 29. Typical Oil Piping for Above Ground (Single-Line) Supply

For L.P. gas, pressure to the gas valve must be more than 11" W.C. but not more than 13" W.C. Pressure is reduced to 11" W.C. by the pressure regulator in the gas valve.

- a. Oil furnace models may be connected to above ground or below ground fuel supply systems. Location for the fuel storage tank is left to the discretion of the owner-user. (Refer to chart attached to burner fuel pump for maximum allowable length of fuel lines.)

#### Oil Gun Models

Your furnace is factory equipped to operate on No. 2 fuel oil. In very cold weather, No. 1 fuel oil should be used.

Do not use motor oil or any fuel other than No. 1 or No. 2 fuel oil in this furnace.

NOTE: Oil storage tank must be free of water, sludge and scale to prevent excessive wear and possible damage to furnace fuel pump and burner nozzle. A fuel filter at the storage tank is required.

#### CONNECTING FURNACE TO FUEL LINE

- a. Connect inlet fuel line to furnace control valve (GAS) or fuel pump (OIL). Approved pipe joint compound (type insoluble to L.P. gas) may be applied on male threads only.
- b. Open fuel line valves and soap test for leak.  
**DO NOT USE OPEN FLAME TEST FOR LEAKS.**

#### PRIMING FUEL PUMP (OIL FURNACE MODELS)

- a. Connect a 3/16" (5mm) I.D. hose to air-bleed valve (see Figure 29) and place other end of hose into a suitable container.
- b. Set furnace thermostat above room temperature and push reset button on burner primary control.
- c. Turn on electrical power to furnace, and set On-Off-Fan switch to "ON" position.
- d. Allow burner to run until discharged oil is free of air bubbles; then shut off air-bleed valve.

### 15. LIGHTING AND FURNACE SHUT DOWN

#### GENERAL-ALL MODELS

Read the safety information on the front page of these installation instructions before lighting furnace. **DO NOT ATTEMPT TO LIGHT FURNACE IF YOU SMELL GAS.**

### SAFETY INFORMATION

#### **WARNING:**

**If you do not follow these instructions exactly, a fire or explosion may result causing personal injury, loss of life, or property damage.**

FOR YOUR SAFETY READ BEFORE LIGHTING.

- a. **The first lighting of the furnace after any home setup must be performed by a qualified service technician.**
- b. If this appliance has a pilot that must be lit by hand, follow these instructions exactly.
- c. **BEFORE LIGHTING** smell all around the furnace for gas. Be sure to smell next to the floor because some gas is heavier than air and will settle on the floor.
- d. **WHAT TO DO IF YOU SMELL GAS:** Do not try to light any appliance. Do not touch any electric switch and do not use any phone in your building. Immediately call your gas supplier from a neighbor's phone. Follow the gas supplier's instructions. If you cannot reach your gas supplier, call the fire department.
- e. Use only your hand to push in the gas control lever. Never use tools. If the lever will not push in by hand, don't try to repair it. Call a qualified service technician. Force or attempted repair may result in a fire or explosion.
- f. Do not use this furnace if any part has been under water. Immediately call a qualified service technician to inspect the furnace and to replace any part of the gas valve or control system which has been under water.

#### **WARNING:**

**Close hinged fire door, if fire door is open or spring is broken it may allow products of combustion into the living space by the furnace blower resulting in possible asphyxiation.**

#### LIGHTING INSTRUCTIONS FOR STANDING PILOT MODELS.

- a. Stop! Read the safety information.
- b. Set the thermostat to the lowest setting.
- c. Turn off all electric power to the appliance.
- d. Push in the gas control lever slightly and move left to "OFF." **DO NOT FORCE.**
- e. Wait ten (10) minutes to clear out any gas. If you then smell gas, **STOP!** Follow step "d" in the SAFETY INFORMATION. If you don't smell gas, go to the next step.

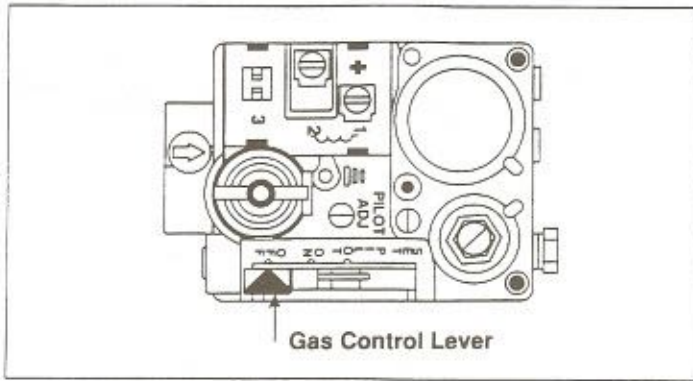

Figure 30. Standing Pilot Valve

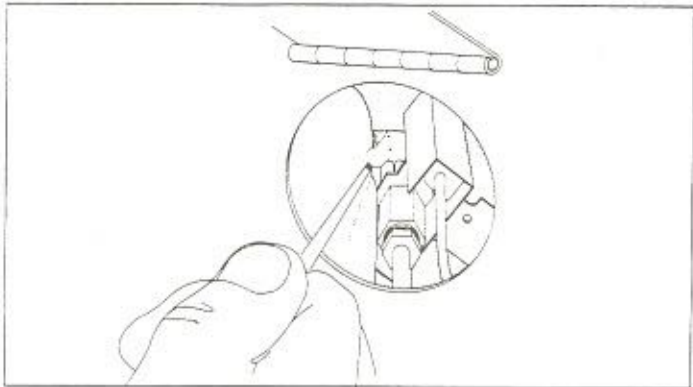

Figure 31. Lighting Furnace

- f. Find pilot - follow metal tube (pilot tube) from gas control valve. Open hinged fire observation door. The pilot is found at the end of the pilot tube just left of the pilot shield.
- g. Slightly depress the gas control lever and move it right to the "ON" position and release; then move it to the "PILOT" position.
- h. Move the control lever to "SET" and hold. Immediately light the pilot with a match. If this furnace is equipped with a Piezo Ignitor, activate spark lever/button several times until flame is visible through observation door. Continue to hold the control lever for about one (1) minute after the pilot is lit. Release the lever and it will spring back to the "PILOT" position. Pilot should remain lit. If it goes out, repeat steps "d" through "h" above. If the lever does not spring back when released, stop and immediately call your service technician or gas supplier. If the pilot will not stay lit after several tries, move the gas control lever to "OFF" and call your service technician or gas supplier.
- i. Move the gas control lever left to "ON".
- j. Turn on all electric power to the furnace. Set the thermostat to "Heat" and/or the desired temperature setting. Set the On-Off-Fan switch to "ON".
- k. Replace the furnace door.

## ! WARNING:

Close hinged fire door, if fire door is open or spring is broken it may allow products of combustion into the living space by the furnace blower resulting in possible asphyxiation.

In the event of any flashback or explosion, immediately shut off the furnace and call your service technician.

### TO TURN OFF GAS TO APPLIANCE:

- a. Set the thermostat to the lowest setting.
- b. Turn off all electric power to the appliance at breaker or fuse box, before servicing.
- c. Remove the furnace door.
- d. Push in the gas control lever slightly and move to the left to "OFF." DO NOT FORCE.
- e. Replace the furnace door.

### SEQUENCE OF OPERATION FOR STANDING PILOT

- a. On a call for heat, the thermostat contacts close, supplying 24 VAC to the relay module.
- b. When the gas valve is energized it steps open at a reduced flow and opens fully after approximately 14 seconds.
- c. When the call for heat is satisfied the thermostat contacts open, the gas valve closes.

### SEQUENCE OF OPERATION FOR STANDING PILOT W/ INDUCED DRAFT BLOWERS MODELS (090PQ)

- a. On a call for heat, the thermostat contacts close, supplying 24 VAC to the relay.
- b. The relay contacts close and energize the induced draft motor.
- c. When the motor reaches approximately 80% of full speed the proving switch closes and energizes the gas valve.
- d. When the gas valve is energized it steps open at a reduced flow and opens fully after approximately 14 seconds.
- e. When the call for heat is satisfied the thermostat contacts open, the gas valve closes, and the induced draft blower stops.

### GENERAL-DIRECT IGNITION MODELS

Read safety information on front page of these installation instructions before operating furnace. **DO NOT ATTEMPT TO OPERATE FURNACE IF YOU SMELL GAS.**



## OPERATING INSTRUCTIONS FOR MM— MODELS WITH DIRECT IGNITION:

- a. STOP! Read the SAFETY INFORMATION.
- b. Set the thermostat to the lowest setting.
- c. Turn off all electric power to the appliance.
- d. This appliance is equipped with an ignition device which automatically lights the burner. Do not try to light the burner by hand.
- e. Push in the gas control lever slightly and push left to "OFF." NOTE: The lever cannot be placed in the "OFF" position unless it is pushed in slightly. DO NOT FORCE (Figure 32).
- f. Wait ten (10) minutes to clear out any gas. If you smell gas, STOP! and follow step "d" in the SAFETY INFORMATION section. If you don't smell gas, go to the next step.
- g. Set the On-Off-Fan switch to the "ON" position.
- h. Push the gas control lever to the "ON" position.
- i. Turn on all electric power to the appliance.
- j. Replace the furnace door.
- k. Set the thermostat to "HEAT" and the desired temperature setting. The furnace should light after approximately 45 seconds. If the appliance will not operate, follow the instructions "To Turn Off Gas To Appliance" and call your service technician or gas supplier.

In the event of any flashback or explosion, immediately shut off the furnace and call your service technician.

### TO TURN OFF GAS APPLIANCE:

- a. Set the thermostat to the lowest setting.
- b. Turn off all electric power to the appliance before servicing unit.
- c. Set the ON-OFF-Fan switch to "OFF."
- d. Push in the gas control lever slightly and move left to "OFF." DO NOT FORCE.
- e. Replace the furnace door.

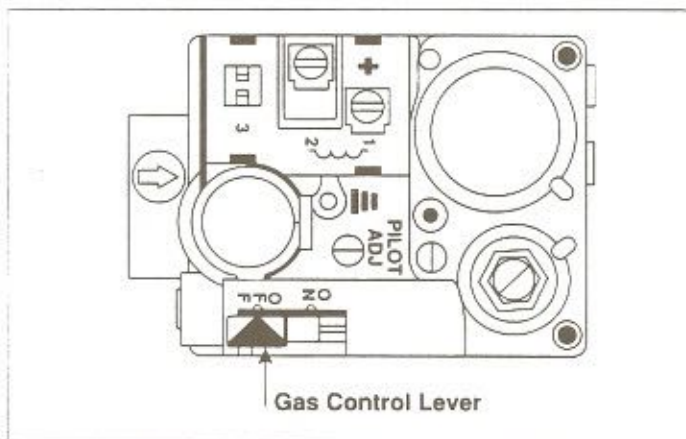

Figure 32. Direct Ignition Gas Valve

## SEQUENCE OF OPERATION FOR MM MODELS WITH DIRECT IGNITION

Direct ignition model furnaces do not have a pilot. Ignition is accomplished automatically by a silicon carbide hot surface ignitor. A control module takes care of all timing functions. After lighting, the control module uses the ignitor as a flame sensor, shutting off gas should the flame go out. There are no external relays or timing devices.

**Do not try to light this furnace manually. The control module is not field serviceable.**

- a. On a call for heat, the thermostat contacts close, supplying 24 VAC between terminals "C" and "W" of the control module.
- b. The combustion blower motor proving switch energizes when the motor reaches approximately 80% of full speed.
- c. After a 30 second purge period, the ignitor is energized for a 15 second warm-up period, after which the gas valve opens.
- d. The trial period for ignition is approximately 6 seconds, after which the gas valve either remains open if flame is sensed, or closes if flame is not sensed.
- e. If flame is not sensed, the entire sequence is repeated two more times before "lockout" occurs. To reset, wait 30 seconds and then interrupt the 24 VAC power by turning the room thermostat below room temperature, then returning it to the original set point.
- f. When call for heat is satisfied the thermostat contacts open, the gas valve closes.

## OPERATING INSTRUCTIONS FOR OIL AND GAS GUN FURNACE:

### Oil Gun Model

If your furnace model number begins with MS\*\*, the furnace is equipped with an ignition device which automatically lights the burner.

*Do not try to light this furnace manually.*

- a. Open all valves in the oil line.
- b. Be sure the fire door is closed.
- c. Set the thermostat to the lowest temperature setting.
- d. Push the "RED" reset button on the burner primary control.
- e. Set the On-Off-Fan switch to "ON".
- f. Set the thermostat to the desired setting.
- g. If the burner does not light, repeat step "d".
- h. If the burner still does not light, call your qualified service technician.

## SEQUENCE OF OPERATION FOR OIL GUN MODELS

- a. On a call for heat, if the cad cell sees darkness, the thermostat contacts close energizing the burner. The electrode starts sparking.

- b. If the cad sees darkness, power will be allowed to start the burner. If the cad cell sees light, the oil burner will not operate. This is a built-in fail safe which will not allow the burner to fire if there is already fire in the combustion chamber.
- c. If the resistance reading from the cad cell (which the primary control is sensing) does not drop to 300 to 1000 ohms, the oil burner will attempt ignition for 45 seconds, after which it will lock out on safety.
- d. To reset the oil burner, the red button on the primary control must be reset.
- e. When call for heat is satisfied, the thermostat contacts open, and the burner will stop.

## **WARNING:**

**If furnace still does not light, turn the furnace off (described below) and call your technician. In the event of any flashback or explosion, immediately shut off furnace and call your service technician.**

### Gas Gun Models

If your furnace model number begins with MB\*\*, the furnace does not have a pilot. Ignition is accomplished automatically by a silicon carbide hot surface ignitor. A control module takes care of all lighting and timing functions. There are no external relays or timing devices.

*Do not try to light this furnace manually.  
The control module is not field serviceable.*

1. Before operation, smell all around the furnace for gas. Be sure to smell next to the floor because some gas is heavier than air and will settle on the floor. If you smell gas, STOP! and follow the safety instructions below. If you don't smell gas, go to the next step.

## **WARNING:**

### **FOR YOUR SAFETY; WHAT TO DO IF YOU SMELL GAS:**

- Do not try to light any appliance.
- Do not touch any electrical switch; do not use any phone in your building.
- Immediately call your gas supplier from a neighbor's phone. Follow the gas supplier's instructions.
- If you cannot reach your gas supplier, call the fire department. Should overheating occur or the gas supply fail to shut off, disconnect the power at the main circuit breaker and then see "To Turn Off Gas To Appliance."

2. Set the thermostat to the lowest setting.
3. Turn off all electric power to the appliance.
4. This appliance is equipped with an ignition device which automatically lights the burner. Do not try to light the burner by hand.
5. Push in the gas control lever slightly and push left to "OFF." NOTE: The lever cannot be placed in the "OFF" position unless the knob is pushed in slightly. DO NOT FORCE (Figure 33).
6. Wait ten minutes to clear out any gas. If you then smell gas, STOP! and follow the safety information on the preceding page. If you don't smell gas, go to the next step.
7. Set the On-Off-Fan switch to the "ON" position.
8. Push the gas control lever to the "ON" position.
9. Turn on the electric power to the appliance.
10. Set the thermostat to "Heat" and/or the desired temperature setting. The furnace should light in approximately 45 seconds. If the appliance will not operate, follow the instructions "To Turn Off Gas To Appliance" and call your service technician or gas supplier.

*In the event of any flashback or explosion, immediately shut off the furnace and call your service technician.*

### TO TURN OFF GAS APPLIANCE:

- a. Set the thermostat to the lowest setting.
- b. Turn off all electric power to the appliance before servicing unit.
- c. Set the On-Off-Fan Switch to "OFF."
- d. Push in the gas control lever slightly and move left to "OFF." DO NOT FORCE.
- e. For oil, shut off all valves.
- f. Replace the furnace door.

### SEQUENCE OF OPERATION FOR GAS GUN MODELS

- a. On a call for heat, the furnace control begins an ignition sequence which lasts approximately 45 seconds.
- b. After this sequence, the control module tests to see if flame is sensed. If it has, the furnace continues to heat until the thermostat is satisfied.
- c. If the burner has not lit, the ignition sequence is repeated a maximum of two more times. If flame is not sensed after three attempts, the control enters "Lockout" and no further attempts to light the burner will occur. If "Lockout" occurs, contact a qualified service technician for assistance.
- d. When call for heat is satisfied, the thermostat contacts open and the gas valve closes.

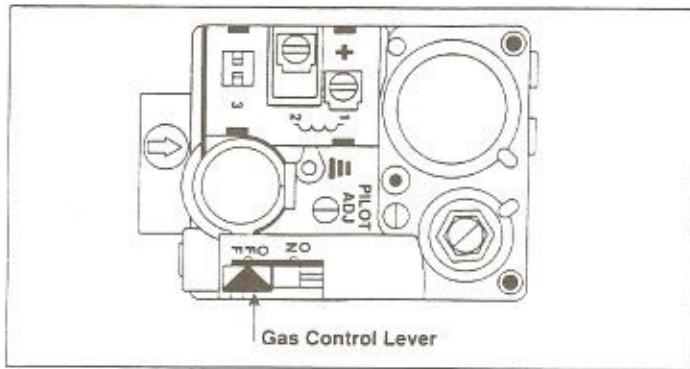

Figure 33. Gas Gun Gas Valve

### Factory Combustion Air Settings

MBHB - 066	= 1 1/2 to 2
MBHB - 086	= 3
MSHA - 066	= 4
MSHA - 086	= 5

Table 9.

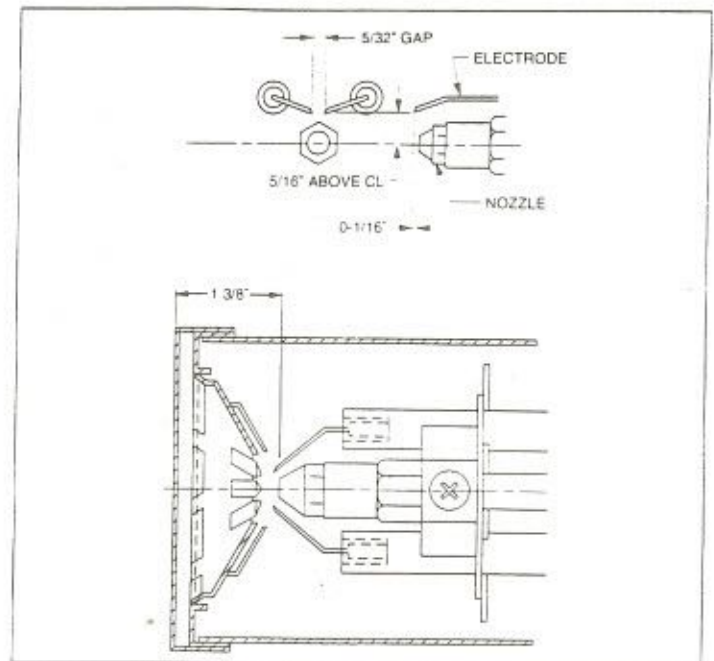

Figure 34. Model AF-9 Beckett Burner

## THE FURNACE CONTROLS AND FUNCTIONS

1. On-Off-Fan Switch - This switch turns electrical power to the furnace on and off, or turns the blower on continuously if set in the "Fan" position. The switch must be set in the "On" position for the furnace to operate. In warm weather, there is a possibility of the blower coming on periodically or operating continuously due to a heat buildup within the furnace by a combination of warm weather and heat from the pilot. This is normal operation as long as there is power to the furnace and the On-Off-Fan switch is at the "ON" position. If blower operation is not desired, the On-Off-Fan switch may be set in the "OFF" position to cut the electrical power to the furnace.
2. Limit Control - This furnace is protected by two high temperature safety limit switches. The auxiliary (upper) limit switch and the high temperature (lower) limit switch are automatic reset types. If either limit trips, the burner will shut off. If either limit switch trips off again soon after resetting, set the furnace On-Off-Fan switch to the "OFF" position and call your authorized serviceman.

### **⚠ DANGER:**

Before placing the furnace in service it must be checked to make sure it is equipped for the type of gas being used. The burner flame must also be observed and adjusted if necessary. Failure to observe this caution may result in unsafe operation, explosion and/or fire, or asphyxiation. See the following sections "Gas Supply" and "Combustion Air."

3. Gas Valve - (MG, MM, and MB) The gas valves for the gas furnaces are a 100% shut-off type and will fail safe if for some reason the gas is turned off. The valve is a "step-open" type which means it opens to a "low-fire" position, and after a few seconds, "steps-open" to "high-fire."
4. Roll Out Switch - (MG - 056, 070 & 077) The furnace is protected by a manual reset safety switch located on the lower air box.
5. Oil Burner Primary Control - The primary control for oil gun furnaces starts the burner, monitors a safe operating cycle, and shuts the burner off at the end of a heating cycle. The control uses a light sensing transducer to determine if fuel ignition has been successfully attained. If ignition is not attained by the end of the safety ignition timing period, the control shuts the burner off and enters "lock-out."
6. a. Summer Cooling - (A-series furnaces): Your furnace is equipped to operate the circulating fan only. Turn the On-Off-Fan switch to the "FAN" position during warm weather. The blower will now operate to circulate air in your home through the duct system.
  - b. Summer Cooling - (B series furnaces): Your furnace is A/C ready, equipped with A/C relay and transformer. The unit is equipped to use a 4-wire thermostat. When using a 5-wire thermostat, RC and RH should be jumped (see instructions included with thermostat). If a 2-wire thermostat is used with the B-series furnaces, it will be necessary to use 2-wire relay kit, (p/n #902649).

## 16. SERVICE GUIDE

### BURNER ADJUSTMENTS

Burner settings and adjustments are made at the factory. However, these settings may change during shipping, handling, and installation. Therefore the following items should be checked and readjusted if necessary.

Atmospheric Gas with Standing Pilot and Direct Ignition Furnaces, Including Gas Gun.

#### a. Gas Pressure

The gas pressure can be checked with a manometer at the pressure tap located on the side of the gas valve. The gas valve pressure regulator can be adjusted by removing the regulator selector stack and turning the slotted insert located directly under the selector stack. The regulator selector stack must be secured in place before each pressure reading is taken. Natural gas manifold pressure should be 3.5" W.C. and L.P. gas manifold pressure should be 11" W.C. Replace the gas pressure tap plug on the gas valve.

#### b. Pilot Flame (Standing Pilot Only)

The pilot flame can be adjusted by turning the pilot adjustment screw, located on top of the gas valve (See Figure 30). The same pilot orifice is used with both natural and L.P. gas.

### COMBUSTION AIR-GAS GUN MODELS

In order for the flame to burn efficiently, it must receive adequate combustion air. The amount of combustion air can be changed by operating the burner air shutter adjustment rod located on the side of the air inlet box. The adjustment rod is set at an AVERAGE position at the factory which is satisfactory for most locations and applications. The amount of combustion air required will vary depending on altitude, actual B.T.U. content of the fuel being used, gas pressure, conversion to another gas and other factors. The burner flame should be observed and any necessary adjustments made before the furnace is placed into service.

## ⚠ CAUTION:

- Combustion air adjustment must be made only by a qualified technician. Improper air adjustment may cause unsafe operation, explosion and/or fire asphyxiation.
- If the input to the furnace is too great because of excessive gas pressure, wrong size nozzle or orifice, high altitude, etc., the burner flame will be sooty and can produce carbon monoxide, which could result in unsafe operation, explosion and/or fire or asphyxiation.

### Gas Gun

Combustion air adjustment is made to the main burner by loosening the lock nut on the plastic air shutter, located on the side of the plastic burner air inlet box. Move the threaded rod to a smaller number (counterclockwise) for less air, to a larger number (clockwise) for more air. Tighten the lock nut after completing the adjustment. For best results, use instruments to measure between 9-10% CO<sub>2</sub> after the combustion air has been adjusted.

### Oil Gun Only

It is advisable to use instruments for maximum performance and efficiency. If instruments are used, readings should be 11-12% CO<sub>2</sub>, with number 1 smoke or less, and 0 to 0.02 negative draft over fire.

### Electrode Setting (Oil Gun Only)

Poor ignition of the oil spray may result if the electrodes are not adjusted as shown in Figure 34. Do not permit any electrodes to be grounded to any surface.

### GAS CONVERSION

This gas fired heating appliance was shipped from the factory for use with natural gas. However, the appliance can be converted for use with L.P. gas. Use the following procedure for gas conversion of the burner.

### ATMOSPHERIC AND DIRECT IGNITION FURNACES

- Follow the instructions to "Turn Off Gas to the Appliance."
- Disconnect the gas pipe union and the electrical wires connected to the gas valve.
- Remove the pilot tube and thermocouple from the gas valve (MG,MM), or disconnect gas burner electric cord, gas piping to burner, and thermostat leads (MB).
- To remove the gas valve assembly, remove hitch pin and screw from gas valve bracket. Gas valve and spud may be removed. Orifice is located at the end of the spud (MG,MM) or remove three (3) bolts from U-shaped manifold plate and orifice assembly (MB).

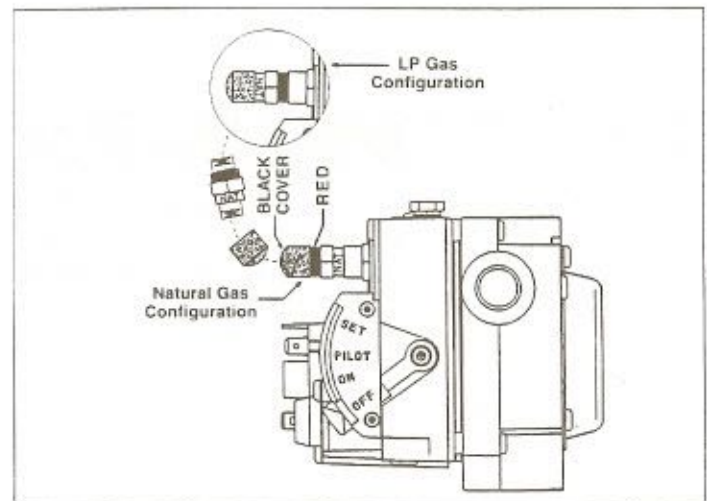

Figure 35.

- e. Replace the main orifice with the L.P. gas orifice supplied in the envelope located by the gas valve. Check to insure the orifice size matches the nameplate.
- f. *It is not necessary to convert the pilot orifice.*
- g. For the gas valve with the regulator converter (Figure 35), remove the black cover and unscrew the converter located on top of the gas valve. Invert the converter. (For "LP" the red ring will be located at the bottom and the "LP" stamping on the converter will appear right side up.) Then screw converter back into the regulator, hand tight plus 1/8 turn, and replace the black cover onto the converter top to protect the threads.
- h. Reassemble the burner assembly into the furnace.
- i. Reconnect the gas piping and electrical wires to the gas valve.
- j. Open the manual shut-off valve and follow the FURNACE START-UP procedure as outlined previously in this manual to put the furnace into operation.

NOTE: The pilot flame is adjustable by turning the adjustment screw located on the gas valve with a small screwdriver. (See Figure 30)

## TROUBLESHOOTING - STANDING PILOT MODELS

### *Main Burner Does Not Come On*

- a. Check the electrical supply to the furnace.
- b. Be sure the furnace On-Off-Fan switch is in the "ON" position.
- c. Check for proper thermostat operation.
- d. Check for broken or open thermostat wires.
- e. Check to make sure the insulation located on the inside of the front panel is glued securely around the fan switch and the limit switch.
- f. Shut off the electrical supply to the furnace and remove the electrical box cover.
  - Check for a defective transformer.
  - Check electrical circuit for proper grounding, polarity, and make sure the electrical connections are tight.
  - Check to see if the lower limit switch may have failed to close.
- g. Replace the electrical box cover and restore electrical power to the furnace. Turn the On-Off-Fan switch to "ON" and raise the thermostat setting above room temperature.
  - Check for 24 volts at the gas valve.
  - Replace the gas valve if the pilot is established and it does not open when powered with 24 volts.
- h. Check manual reset limit switch located at lower air box next to combustion air chute.

### *Gas Valve Powered (24 volts)- No Main Flame*

- a. The manual shut-off valve must be on.
- b. The pilot flame must be established.
- c. The gas valve control lever must be in the "ON" position.
- d. Check gas pressure coming to the gas valve.
- e. Replace the gas valve if the main burner does not come on under the above conditions.

### *Pilot Will Not Light or Goes Out*

- a. Check the incoming gas pressure.
- b. Check for the proper pilot orifice. See the nameplate SPECIFICATION.
- c. Check for proper pilot flame adjustment. See "BURNER ADJUSTMENTS."
- d. Check the thermocouple millivoltage.
  - Millivoltage should read between 18 and 30 mv.
  - If the closed millivolt reading is not between 18 and 30 mv., the gas valve electromagnet may be defective. Replace the gas valve if necessary.
- e. Be sure the pilot shield is in place.
- f. Check for gas leaks in the pilot line or the pilot assembly.
- g. Check the flue assembly to make sure all connections are tight.
- h. See the FURNACE START-UP procedure for lighting details.

### *Main Flame Is Not Burning Properly*

- a. Check the manifold gas pressure.
- b. Check for the correct main burner orifice.
  - See the nameplate SPECIFICATION.
- c. Check the flue for any blockages or loose connections.
- d. Check the combustion air passages for blockage.

### *High Gas Bills*

- a. Be sure the proper orifices are being used.
- b. Be sure the return air system is clear and free of blockage.
- c. Be sure the furnace filter is clean.
- d. Be sure the home is insulated, that windows and doors fit tightly, and that there are no leaks in the heating duct system.
- e. Check the room thermostat to be sure the setting is not higher than necessary. Low humidity requires higher temperatures for the same level of comfort. Check for proper humidity level in the home.

## TROUBLESHOOTING - DIRECT IGNITION FURNACES INCLUDING GAS GUN

### *Burner Motor Does Not Run—Thermostat Calls For Heat*

- a. Defective thermostat circuit - jumper T, T connections on burner junction box (gas gun) or white and red thermostat low voltage leads (standard direct ignition model). If the burner motor runs, check:
  - Thermostat connections
  - Thermostat
- b. No voltage to control module - determine if 120 volts is available to the control module. If voltage is not available check for:
  - Blown fuse, circuit breaker, no electrical supply.
  - Limit switch open.
  - Loose connections.

#### **Combustion Blower Does Run - No Flame**

- a. Defective centrifugal switch.
  - Check the operation of centrifugal switch by removing end bell of the burner motor.
  - Clean contacts of motor.
  - If the contacts are closed, replace the motor.
- b. Burner in purge mode - allow 2 minutes for flame establishing period.
- c. Check for proper electrical connections at purge timer, control box, or gas valve.
- d. Check for gas supply - gas line valve on, control lever on.

#### **Control Module Is Powered— Ignitor Does Not Heat Up**

- a. Disconnect ignitor leads at AMP receptacle and check for 120 volts at the plug during ignition sequence.
- b. Replace ignition control if 120 volts is not available at AMP plug during ignition sequence.

#### **Control Module Status Indicator**

- a. One flash - the control is in lock-out because the inducer pressure switch is or was stuck closed.
- b. Two flashes - the control is in lockout because the signal was not received by the control that the inducer pressure switch had closed within the time.
- c. Three flashes- the control is in lockout because a failed ignition attempt, a gas valve error, or a false flame sensed during the warm up period. If false flame has been sensed, the control will return to normal operation, and repeat ignition sequence when the false flame is not present.
- d. Four flashes- the control is in lockout due to a failure within the control board.

#### **120 Volts Is Available At AMP Plug— Ignitor Does Not Heat Up**

- a. Disconnect power to the furnace.
- b. Disconnect AMP plug to the ignitor, and check ignitor resistance with an ohm meter. Set on RX1 scale.
  - Normal reading should be 40 - 75 ohms.
  - If above or below this rating at room temperature change ignitor.
- c. Check for continuity from ignitor receptacle to burner.

#### **Main Flame Ignites— Burner Locks Out**

- a. Ignition control is not properly grounded.
- b. Defective ignition control.
- c. Improper polarity of 120 volt power supply.
- d. Ignitor has hairline crack.
- e. Improper gas pressure or burner air adjustment is not allowing flame to contact ignitor tip for flame rectification.
- f. Misaligned ignitor does not allow flame to contact ignitor tip for flame rectification.

#### **Burner Short Cycling —**

##### **Thermostat Calls for Heat, Limit Switches Closed**

- a. Check for polarity.
- b. Check ground.
- c. Check flue.
- d. Check combustion air.
- e. Check gas pressure.
- f. Check orifice.
- g. Check the position of ignitor, a normal reading should be 40-75 ohms.

##### **24 Volts Supplied To Gas Valve During Ignition — No Main Gas Flow**

- a. Gas valve may be defective. Replace if necessary.
- b. Gas piping may be plugged. Check for adequate gas supply to gas valve at union.

#### **Burner Operates— Insufficient Heat**

- a. Check thermostat for proper setting and location. Thermostat should not be located where it will be affected by another heat source.
- b. Check for clean filter and proper air flow.
- c. Check burner for proper gas firing rate.
- d. Be sure unit is not undersized for its thermal load.
- e. Check thermostat anticipator. The nominal anticipator setting is 0.4.

#### **Burner Flame Without Motor Running**

- a. Gas valve stuck open, check gas valve for proper operation (replace if necessary) and inspect heat exchanger.
- b. Check for 115 volts to the combustion blower motor; replace if necessary.
- c. If no power to combustion blower then check wiring and control module; replace if necessary.

#### **Circulation Air Blower Will Not Operate Even Though The Burner Does Operate**

- a. Set the On-Off-Fan switch to the "FAN" position. If the blower operates, check for a defective fan switch.
- b. Check wiring to motor.
- c. Check for a defective motor.

### **ADDITIONAL OIL FURNACE MAINTENANCE**

In addition to the preceding, the following should be performed by a qualified service contractor at least once each season for oil-fired furnaces:

- a. Replace the oil nozzle with the type nozzle specified for your furnace.
- b. Clean, adjust and replace if necessary the spark electrodes.
- c. Reset the nozzle/drawer assembly to factory specifications.
- d. Clean the inside of the furnace heat exchanger and replace the combustion liner if necessary.
- e. Clean or replace the oil filter element at the oil tank.
- f. Adjust the burner for top efficiency and check to make sure all fittings are leak-tight.

## MAINTENANCE

### By Homeowner

1. Return Air - On some closet installations the return air opening to the furnace may be on the floor, on the door, on the side wall of the closet, or some combination of these. The upper grille on the front of the furnace admits return air to the blower. Return air must be provided back to the circulating blower in order to provide air distribution.
2. Filters - At least twice each season (more often in dusty areas) remove and clean the air filters with a vacuum or with warm water and soap. Reinstall when dry. Also clean dust and lint around furnace and in the furnace vestibule.
3. Seasonal Service Information - During extremely cold weather, ice may form on the furnace roof jack. Small amounts of ice forming on the roof jack will present no problems to proper furnace operation. Excessive ice formation could restrict the combustion air supply to the burner, causing inefficient burner operation. If excessive ice has formed on the air inlet or exhaust portions of the roof jack, it must be carefully removed (Figure 37).

### **⚠ WARNING:**

Do not obstruct any return air openings, including the grille on the furnace. To do so may cause the furnace to activate the high limit and shut down, or it may cause asphyxiation.

### By Serviceman

All furnaces need periodic service at the beginning of each heating season. Call your serviceman to:

- a. Remove the air circulator and clean all dust and lint from the unit with a stiff bristle brush.
- b. Inspect the combustion chamber blower compartment, flue collar and Roof Jack.
- c. Check the gas valve (if applicable) and fuel line connections for leaks.
- d. Make any adjustments necessary for good operation.
- e. If the blower motor is equipped with oiling tubes, at the beginning of each heating season turn off the furnace On-Off-Fan switch and add 2 to 3 drops of a good

### **⚠ WARNING:**

Use of furnace or air conditioning components that are not included in the certification of this appliance may create a hazard, invalidate the certification, and, in many states, make installations illegal. Listed NORDYNE air conditioning components are specified on the furnace label.

quality SAE 20 motor oil (non-detergent) to the oil tubes at each end of the blower motor. The blower must be taken out of the furnace for access. To remove, take out the screws, unplug the electrical connection and slide the blower out. If oil tubes are not provided, no annual lubrication is required. After oiling, wipe off any excess oil.

## OPTIONAL ACCESSORIES

### Necessary when the Furnace is Used with Some Central Air Conditioners

If an air conditioner is installed that does not use the furnace blower for air distribution and that operates independently of the furnace, the thermostat system must have an interlock to prevent the furnace and air conditioner from operating at the same time. This interlock system usually contains either a "Heat-Cool" switch which must be turned to the "Heat" or "Cool" position to activate either heating or cooling operation, or a positive "OFF" switch on the cooling thermostat.

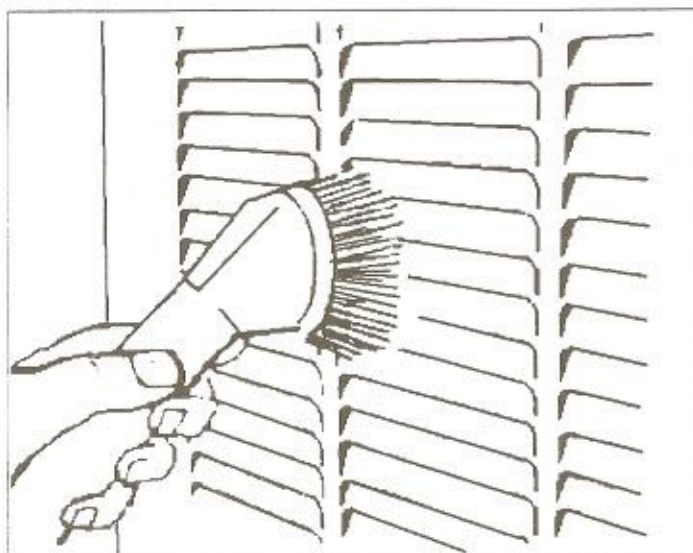

Figure 36. Periodic Cleaning

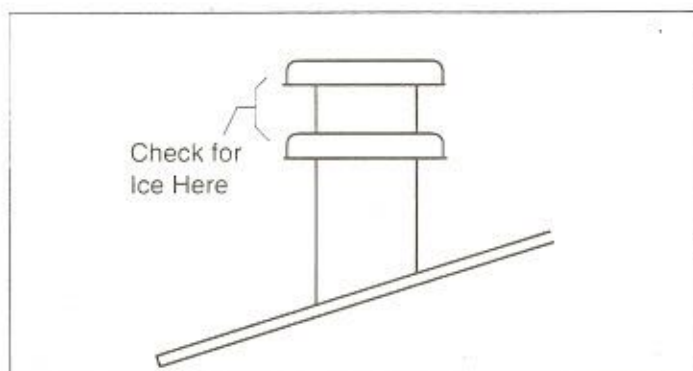

Figure 37. Roof Jack

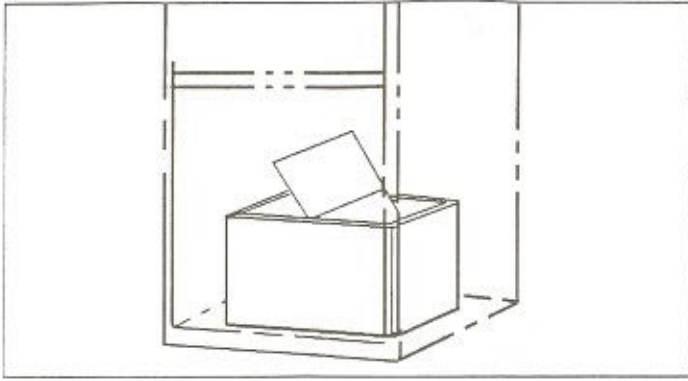

Figure 38. Coil Cavity Damper

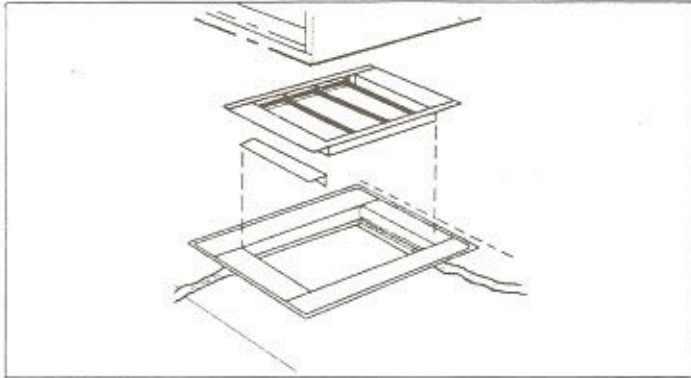

Figure 39. Damper without coil activity

The furnace must also be equipped with an automatic damper (See Figures 38 or 39, NORDYNE p/n 901996 for furnaces without coil cavity, or p/n 901831 with coil cavity) to prevent cold air from being discharged up around the heat exchanger. Cold air may cause condensation inside the heat exchanger which can lead to rust and early failure.

#### OPTIONAL ADD-ON AIR CONDITIONING

Ask your dealer or contractor about NORDYNE add-on central air conditioning systems. There is a split-system or package air conditioner designed for your total comfort needs. Whether split system or single package, an energy-saving NORDYNE unit is available that has been designed specifically for manufactured housing applications and can best handle your home comfort needs.

U.L. Listed and ARI Certified, all models are protected by the NORDYNE Air Conditioner Limited Warranty.

Single package unit includes cooling coils, compressor, and vertical discharge fan (See Figure 40). This type of unit connects with the existing home air duct system (an optional close-off damper is required with the furnace).

Split system unit with vertical discharge for quiet operation connects with NORDYNE cooling coil furnace (optional coil cavity required with "A" model furnaces). (See Figure 41.)

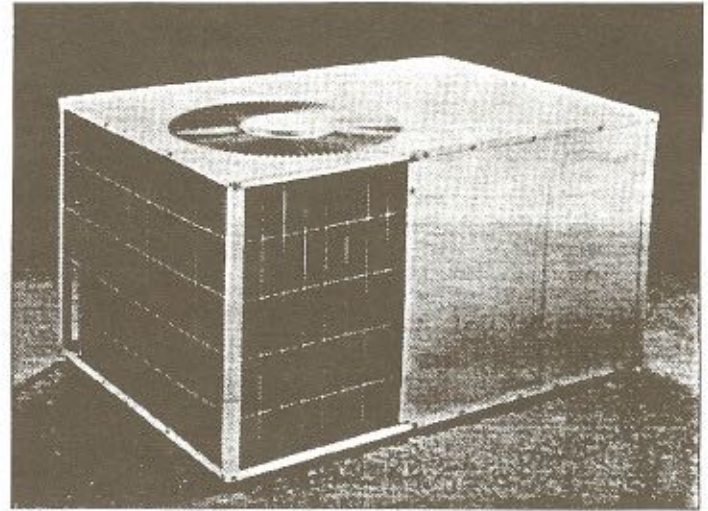

Figure 40. Single Packaged Air Conditioner

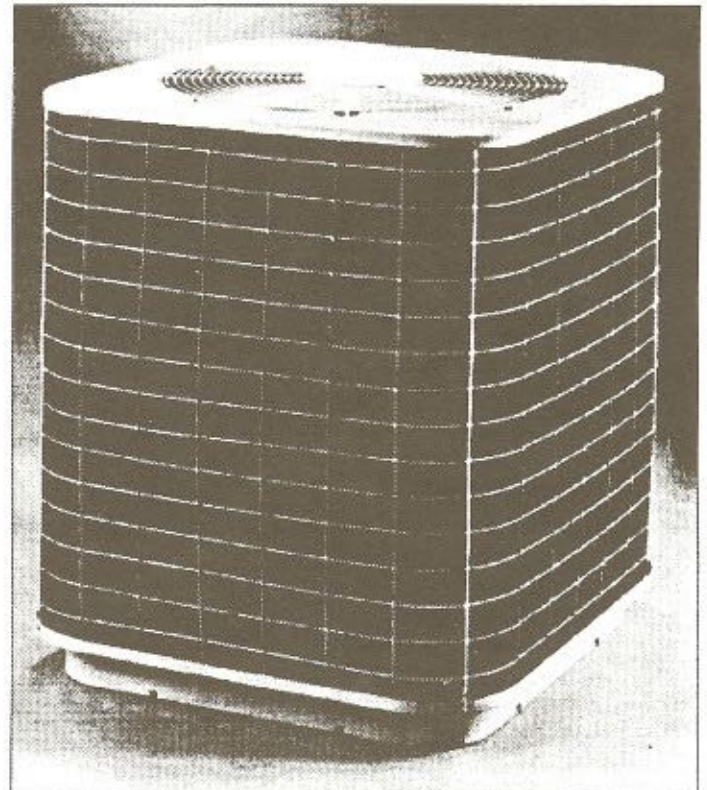

Figure 41. Split System Air Conditioner

#### PILOT ACCESSORY KIT

Avoid using matches to light your pilot burner. Add the NORDYNE Piezo Ignitor Kit. Simply push a button and a hot spark lights your pilot flame. Order accessory p/n 901997 from your distributor.



WIRING DIAGRAMS

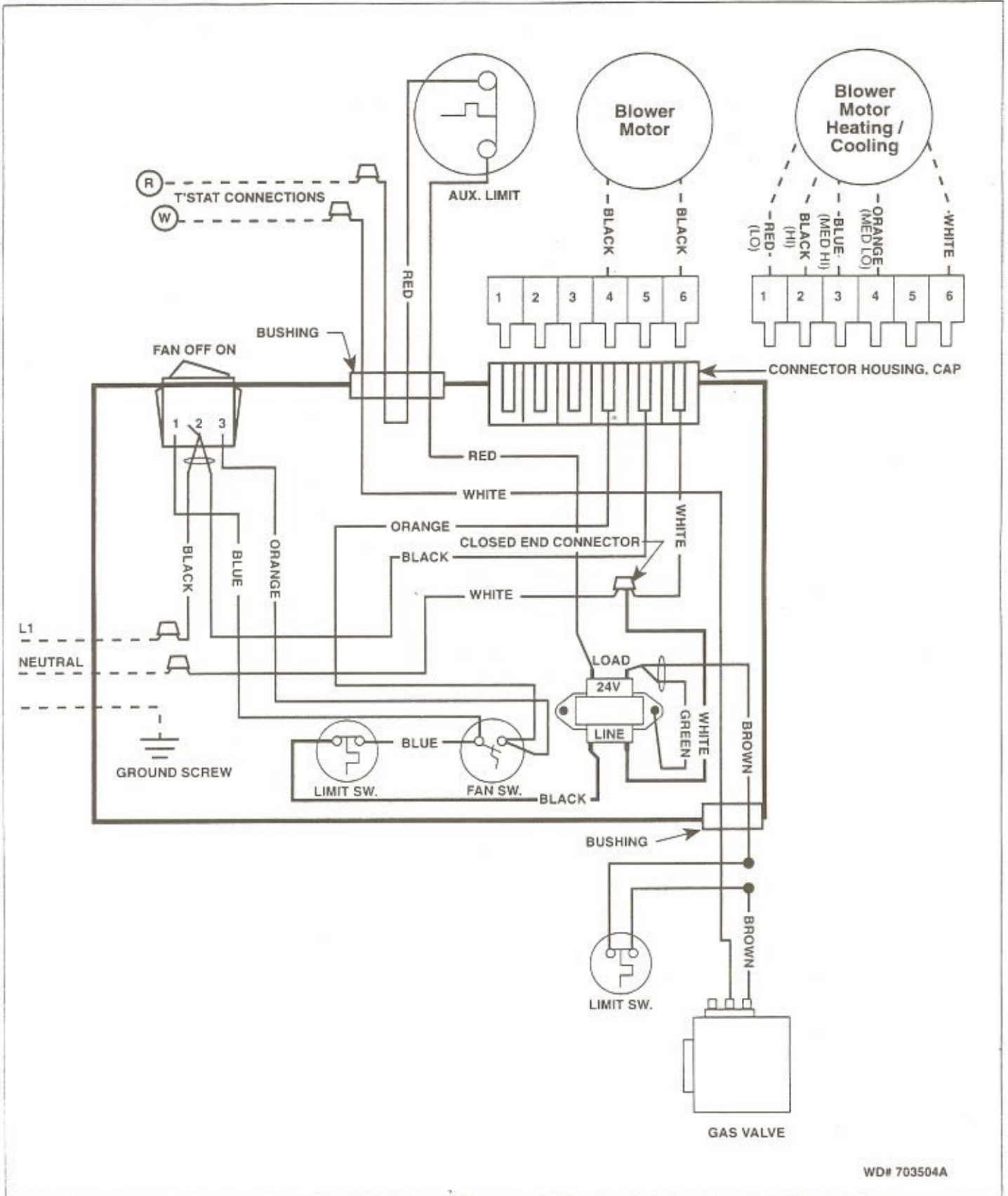

WD# 703504A

Figure 42. Gas Atmospheric  
MGHA 056, 070, 077

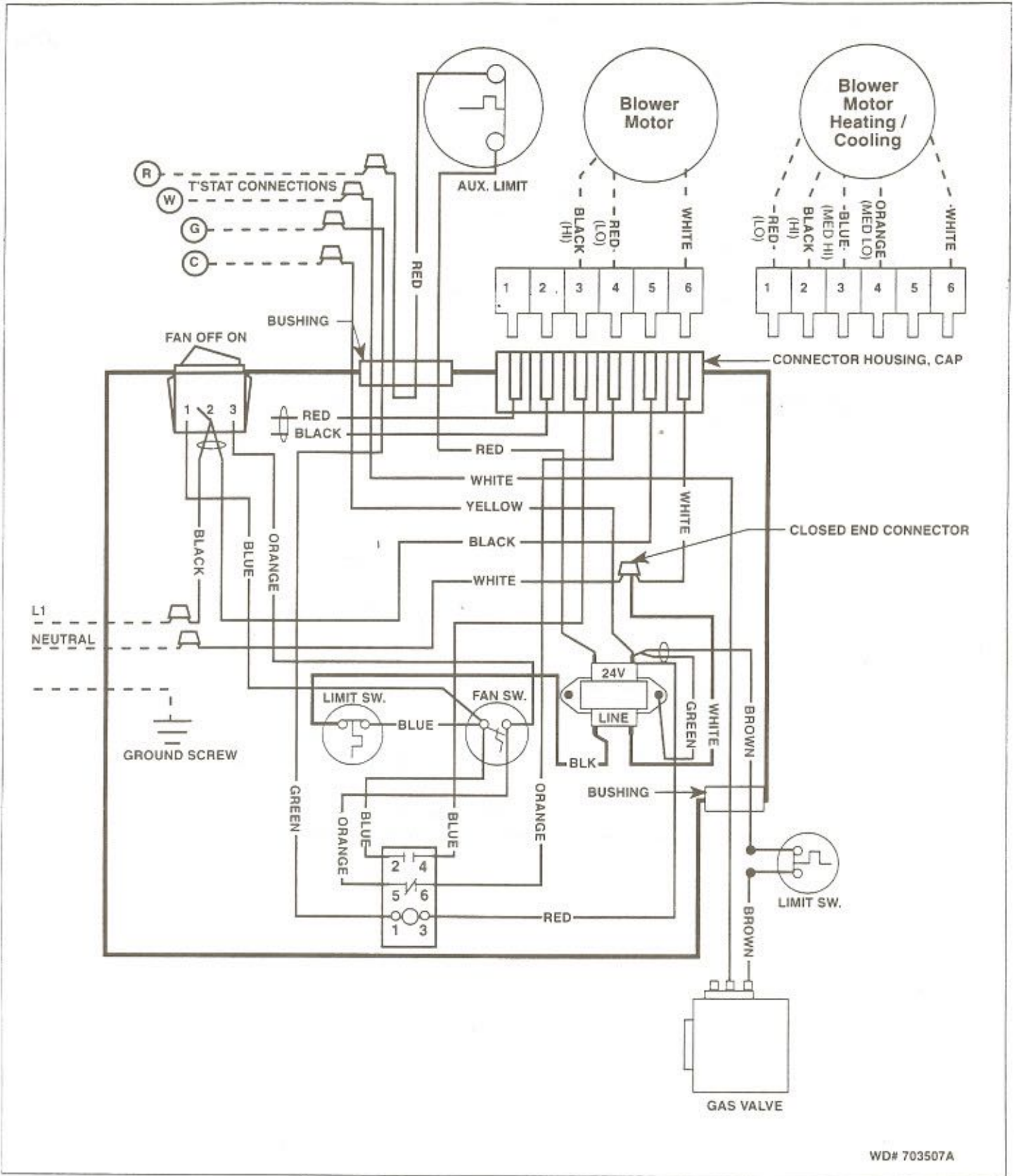

Figure 43. Gas Atmospheric  
MGHB 056, 070 and MGBB 056, 070, 077

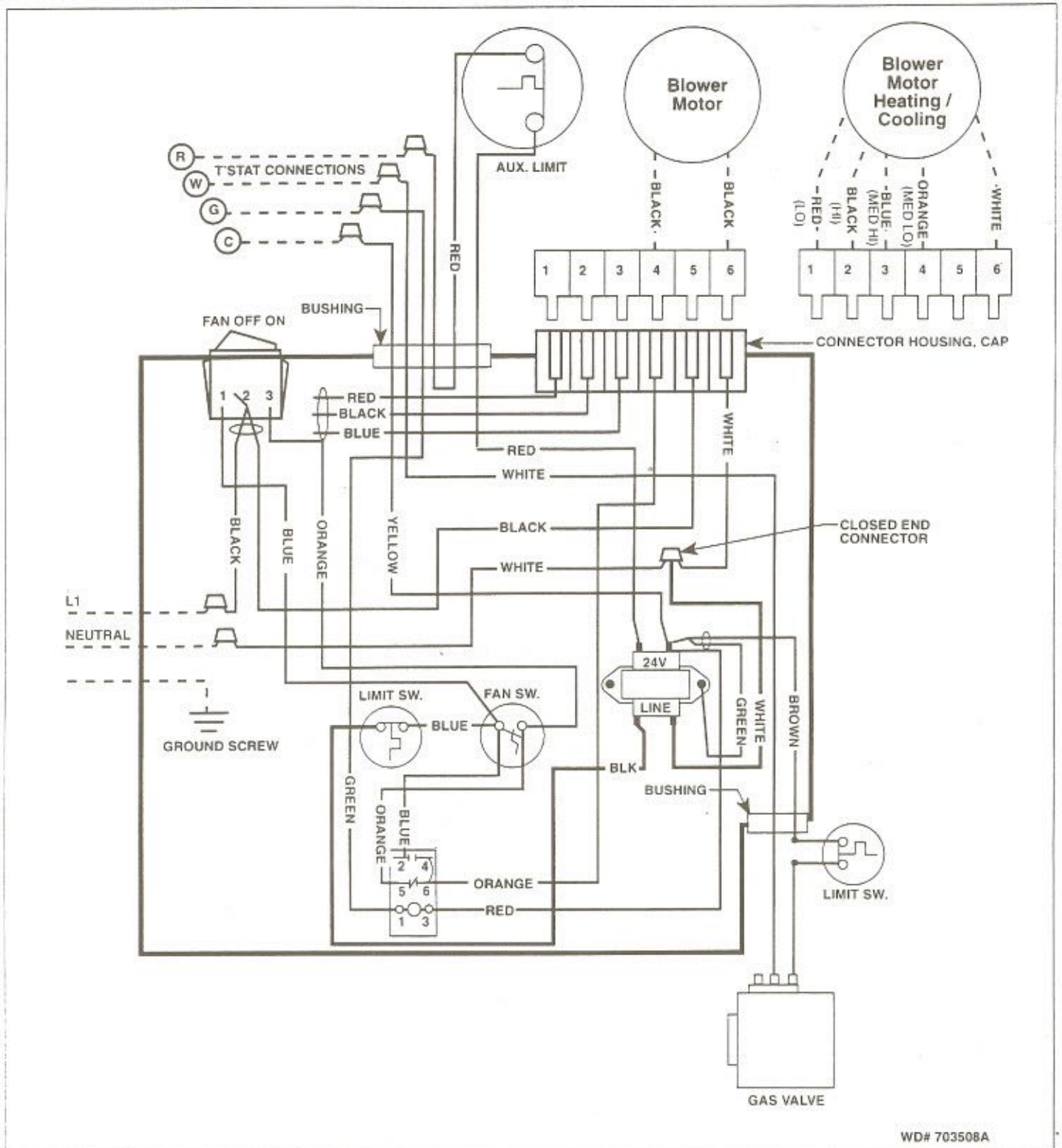

Figure 44. Gas Atmospheric Furnaces  
MGHB 077

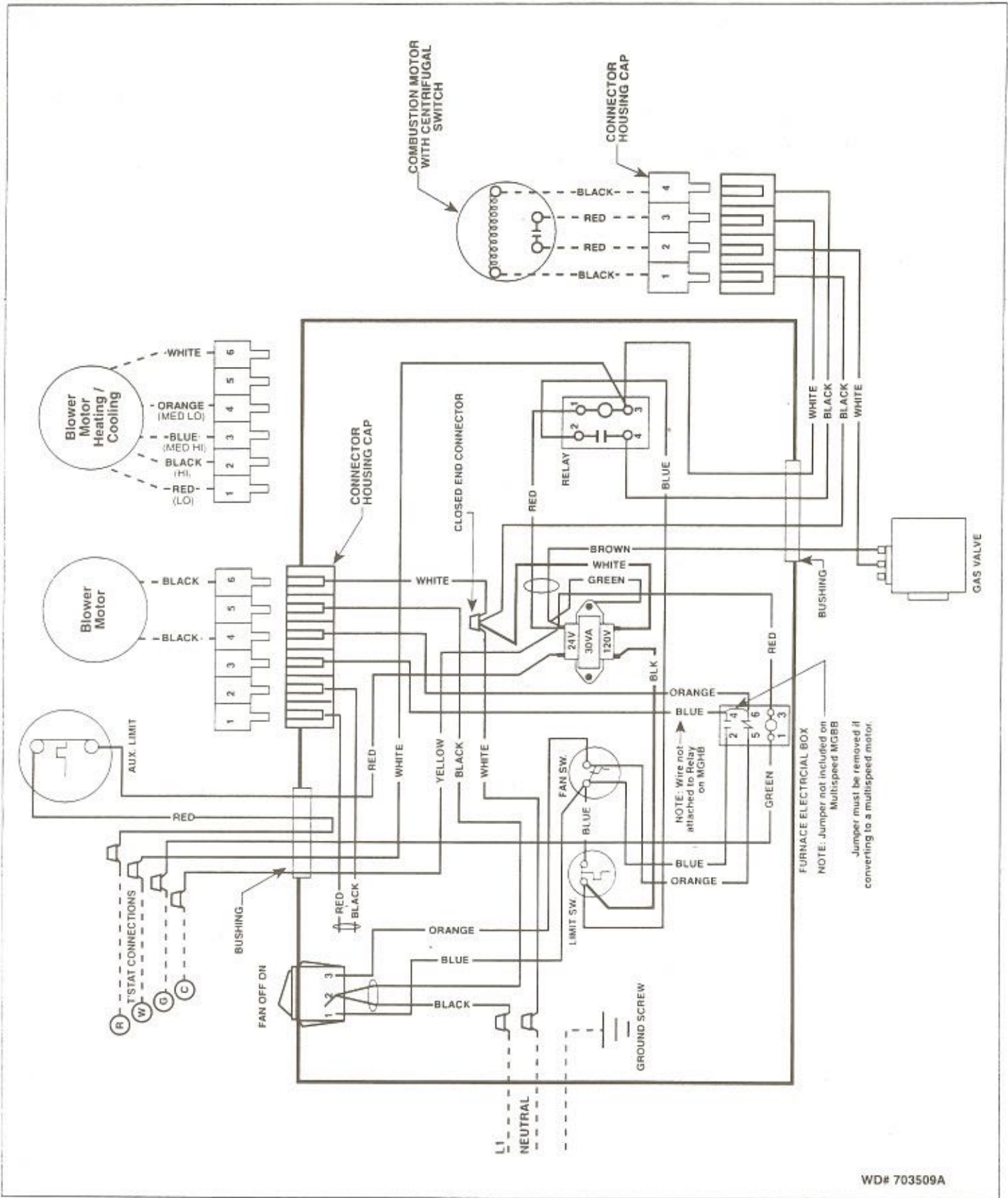
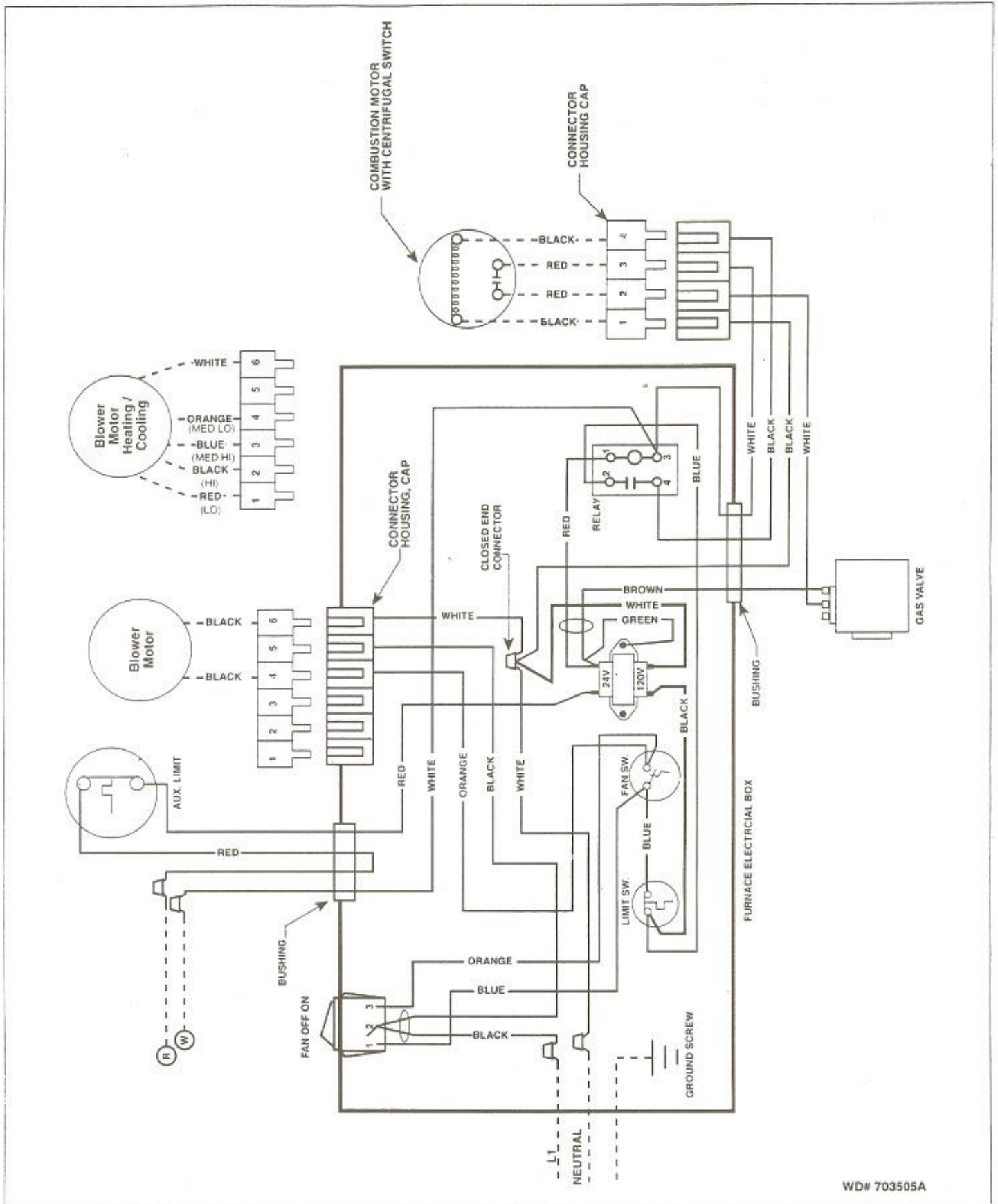

Figure 45. Standing Pilot w/induced Draft Furnaces  
MGHB 090 PQ, MGBB 090 PQ

# WIRING DIAGRAMS



**REPLACEMENT PARTS LIST**

**MG(H,B)(A,B) Series**  
**MM(H,B)(A,B) Series**

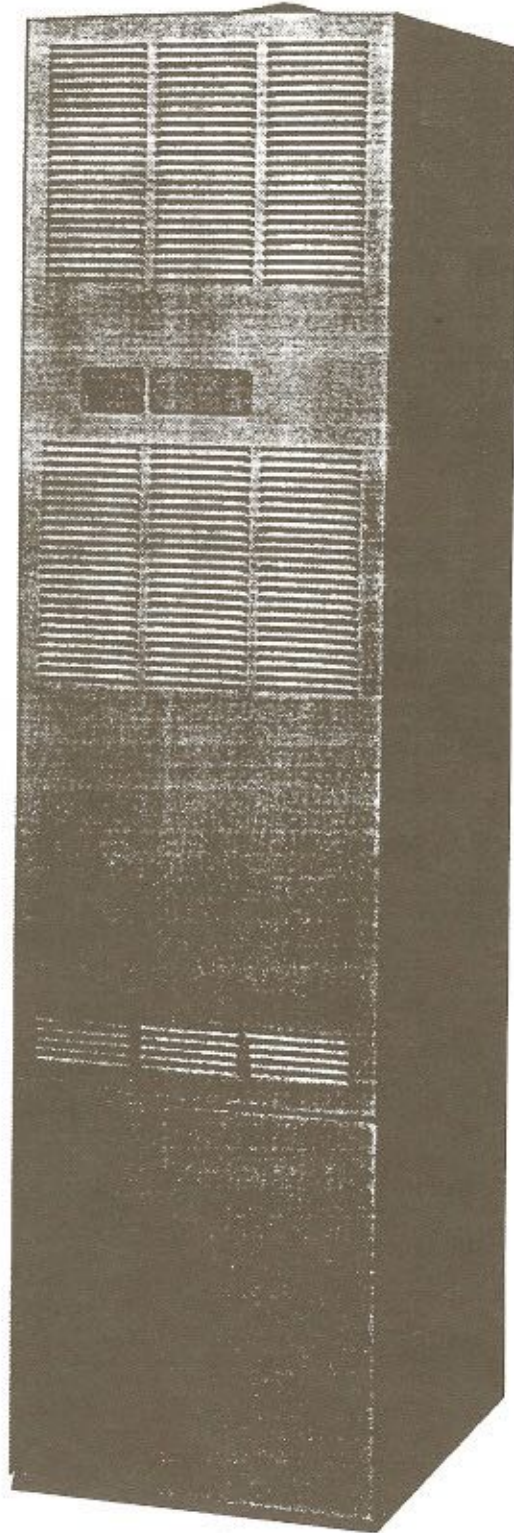

# MG(H,B)(A,B) and MM(H,B)(A,B) Series Gas Furnace

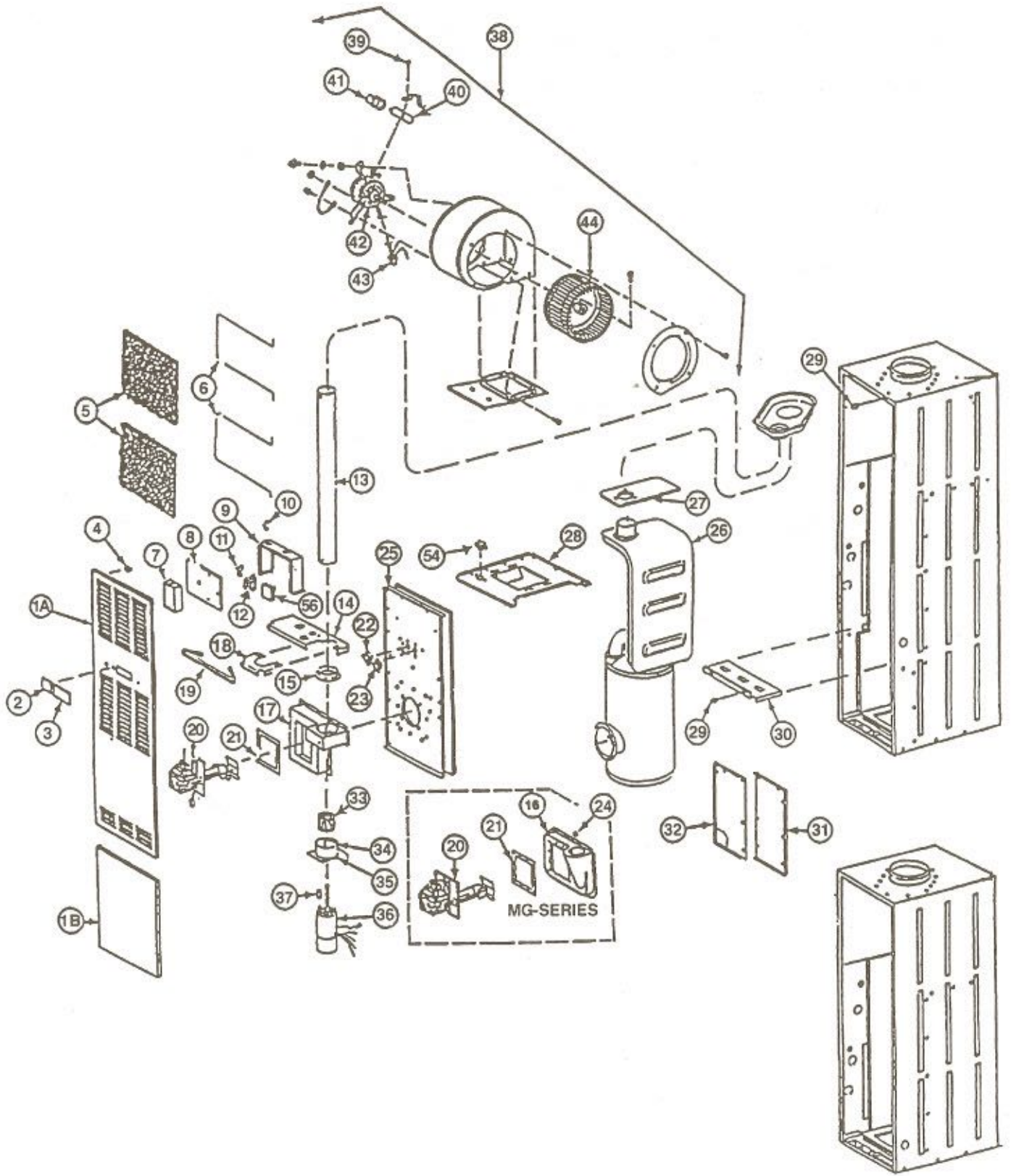

## MG(H,B)(A,B) and MM(H,B)(A,B) Series Gas Furnace Parts List

ITEM NO.	PART NO.	DESCRIPTION	MG(H,B)A				MM(H,B)A				MG(H-B)B				MM(H-B)B			
			-56	-70	-77	-90PQ	-56	-70	-77	-90	-56	-70	-77	-90PQ	-56	-70	-77	-90
1A	902004	Louvered Door	1	1	1	1	1	1	1	1	1	1	1	1	1	1	1	1
1B	902005	Coil Door (B-Cab.)	1	1	1	1	1	1	1	1	1	1	1	1	1	1	1	1
2	687013	Name Plate (Miller)	1	1	1	1	1	1	1	1	1	1	1	1	1	1	1	1
	687012	Name Plate (Intherm)	1	1	1	1	1	1	1	1	1	1	1	1	1	1	1	1
3	668772	Decorative Door Insert	1	1	1	1	1	1	1	1	1	1	1	1	1	1	1	1
4	668420	Door Latch	1	1	1	1	1	1	1	1	1	1	1	1	1	1	1	1
5	669086	Air Filter	1	1	1	1	1	1	1	1	1	1	1	1	1	1	1	1
6	668788	Air Filter Retainer	1	1	1	1	1	1	1	1	1	1	1	1	1	1	1	1
7	626421	Control Module					1	1	1	1								
8	258820	Control Box Cover	1	1	1	1	1	1	1	1	1	1	1	1	1	1	1	1
9	354990	Control Box	1	1	1	1	1	1	1	1	1	1	1	1	1	1	1	1
10	631947	On-Off-Fan Switch	1	1	1	1	1	1	1	1	1	1	1	1	1	1	1	1
11	631728	Cap Pin	1	1	1	1	1	1	1	1	1	1	1	1	1	1	1	1
12	621098	Transformer (30 VA)	1	1	1	1	1	1	1	1	1	1	1	1	1	1	1	1
13	356272	Fresh Air Pipe	1	1	1	1	1	1	1	1	1	1	1	1	1	1	1	1
14	355500	Shelf Divider	1	1	1	1	1	1	1	1	1	1	1	1	1	1	1	1
15	246850	Collar	1	1	1	1	1	1	1	1	1	1	1	1	1	1	1	1
16	493022	Lower Air Box -056	1										1					
	493023	Lower Air Box -070		1									1					
	493024	Lower Air Box -077			1									1				
	493035	Lower Air Box -90PQ				1												1
17	493031	Lower Air Box -056 HSI					1									1		
	493032	Lower Air Box -070 HSI						1									1	
	493033	Lower Air Box -077 HSI							1									1
	493035	Lower Air Box -090 HSI								1								1
18	247360	Close-Off Shelf	1	1	1	1	1	1	1	1	1	1	1	1	1	1	1	1
19	688877	Foam Tape	1	1	1	1	1	1	1	1	1	1	1	1	1	1	1	1
20	902901	Burner MG/less orifice	1	1	1	1					1	1	1	1				
	902902	Burner HSI/less orifice					1	1	1	1					1	1	1	1
21	689009	Burner Gasket	1	1	1	1	1	1	1	1	1	1	1	1	1	1	1	1
22	626338	Limit 150°F	1				1						1			1		
	626341	Limit 155°F			1	1				1	1						1	1
	626279	Limit 140°F		1					1					1			1	
23	626337	Fan 115°F	1	1	1	1	1	1	1	1	1	1	1	1	1	1	1	1
24	626352	Limit, Flame Rollout	1	1	1						1	1	1					
25	492970	Front Air Casing	1	1	1	1	1	1	1	1	1	1	1	1	1	1	1	1
26	902758	2-Pipe Heat Exchanger	1	1			1	1				1	1			1	1	
	902760	3-Pipe Heat Exchanger			1	1							1	1				
	902759	3-Pipe Heat Exchanger							1	1							1	1
27	689055	Heat Exchanger Insulation	1	1	1	1	1	1	1	1	1	1	1	1	1	1	1	1
28	354990	Top Air Casing	1	1	1	1	1	1	1	1	1	1	1	1	1	1	1	1
29	668905	Door Strike	1	1	1	1	1	1	1	1	1	1	1	1	1	1	1	1

\* = Part should be stocked by distributor

Gas Furnace Parts List continued on back page



## MG(H,B)(A,B) and MM(H,B)(A,B) Series (Continued)

ITEM NO.	PART NO.	DESCRIPTION	MG(H,B)A				MM(H,B)A				MG(H,B)B				MM(H,B)B			
			-56	-70	-77	-90PQ	-56	-70	-77	-90	-56	-70	-77	-90PQ	-56	-70	-77	-90
30	355050	Divider Shelf, (B-Cab.)	1	1	1	1	1	1	1	1	1	1	1	1	1	1	1	
31	355490	Right Close-Off (B-Cab.)	1	1	1	1	1	1	1	1	1	1	1	1	1	1	1	
32	355480	Left Close-Off (B-Cab.)	1	1	1	1	1	1	1	1	1	1	1	1	1	1	1	
33	667186	Wheel, Combustion					1								1	1		
	667187	Wheel, Combustion						1	1	1							1	
34	355510	Scroll					1	1	1	1					1	1	1	
35	355860	Mounting Plate					1	1	1	1					1	1	1	
36	621080	Motor, Combustion					1	1	1	1					1	1	1	
37	668785	Grommet					1	1	1	1					1	1	1	
38	902906	Blower Assembly, 56	1				1											
	902903	Blower Assembly, 70		1				1										
	902904	Blower Assembly, 77/90			1	1			1	1								
	902905	Blower Assembly, 56/70									1	1			1	1		
	902809	Blower Assy. (BB-models)									1	1	1	1	1	1	1	
39	606228	Capacitor Strap			1	1			1	1	1	1	1	1	1	1	1	
40	621434	Capacitor 7.5 MFD			1	1			1	1	1	1	1	1	1	1	1	
41	632232	Capacitor Boot			1	1			1	1	1	1	1	1	1	1	1	
42	902042	Motor 1/8 HP	1				1											
	901873	Motor 1/5 HP		1				1										
	901874	Motor 1/4 HP			1	1			1	1								
	901875	1/3 HP(3-Speed)(BB-models)									1	1	1	1	1	1	1	
	902653	Motor 1/3 HP(2-Speed)									1	1			1	1		
43	631724	Circuit Plug	1	1	1	1	1	1	1	1	1	1	1	1	1	1	1	
44	667252	Blower Wheel 10 X 7	1	1	1	1	1	1	1	1	1	1	1	1	1	1	1	
45	624491	Gas Valve (Atm)	1	1	1	1					1	1	1	1				
	624490	Gas Valve (HSI)					1	1	1	1					1	1	1	
46	631132	Thermocouple	1	1	1	1					1	1	1	1				
47	257590	Pilot Tube	1	1	1	1					1	1	1	1				
48	660836	Natural Gas Orifice-056	1				1				1				1			
	660835	Natural Gas Orifice-070		1				1				1				1		
	660834	Natural Gas Orifice-077			1				1				1			1		
	660833	Natural Gas Orifice-090				1				1				1			1	
	660792	L.P. Orifice-056	1				1				1				1			
	660793	L.P. Orifice-070		1				1				1				1		
	660838	L.P. Orifice-077			1				1				1			1		
	660837	L.P. Orifice-090				1				1				1			1	
49	660869	Pilot Burner	1	1	1	1					1	1	1	1				
50	247630	Pilot Shield	1	1	1	1					1	1	1	1				
51	257653	Valve Support	1	1	1	1	1	1	1	1	1	1	1	1	1	1	1	
52	902661	Ignitor Kit					1	1	1	1					1	1	1	
54	626391	Limit 140°, Auxiliary	1	1	1	1	1	1	1	1	1	1	1	1	1	1	1	
55	618020	Pilot Lighter Rod	1	1	1	1					1	1	1	1				
56	620689	Relay, 90PD				1								1				
57	620537	Relay, A/C						1	1	1	1	1	1	1	1	1	1	

9909-1195 (Replaces 9909-0895)

St. Louis, MO

**NORDYNE**

Specifications and illustrations subject to change  
without notice and without incurring obligations.  
Printed in U.S.A. (11/95)

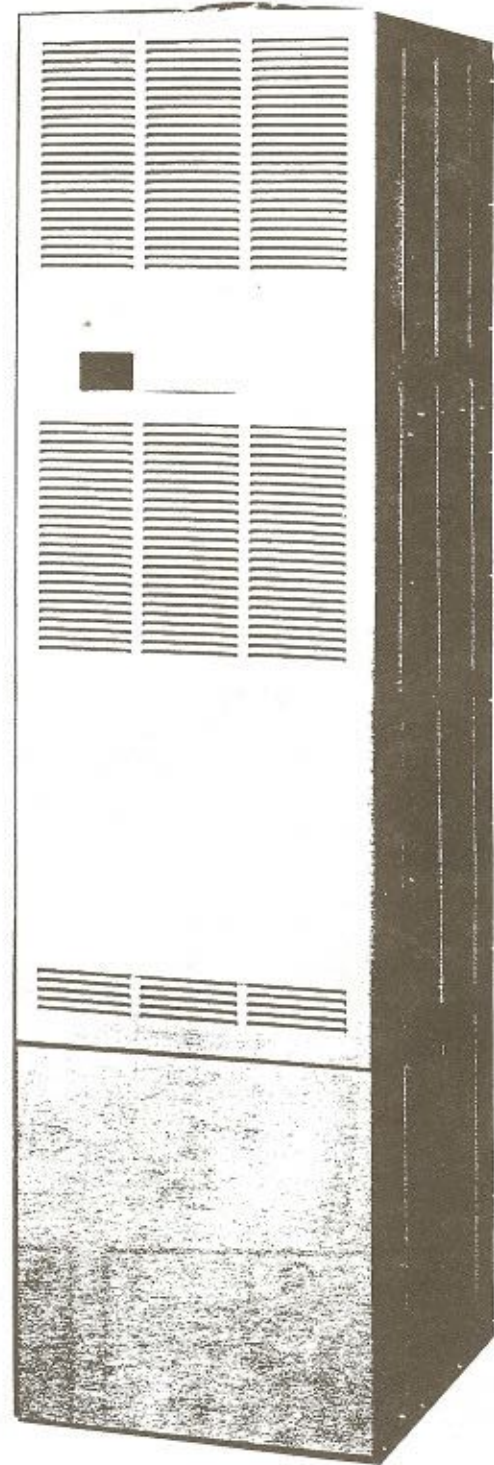

# MG(-)A and MM(-)A Series GAS FURNACE

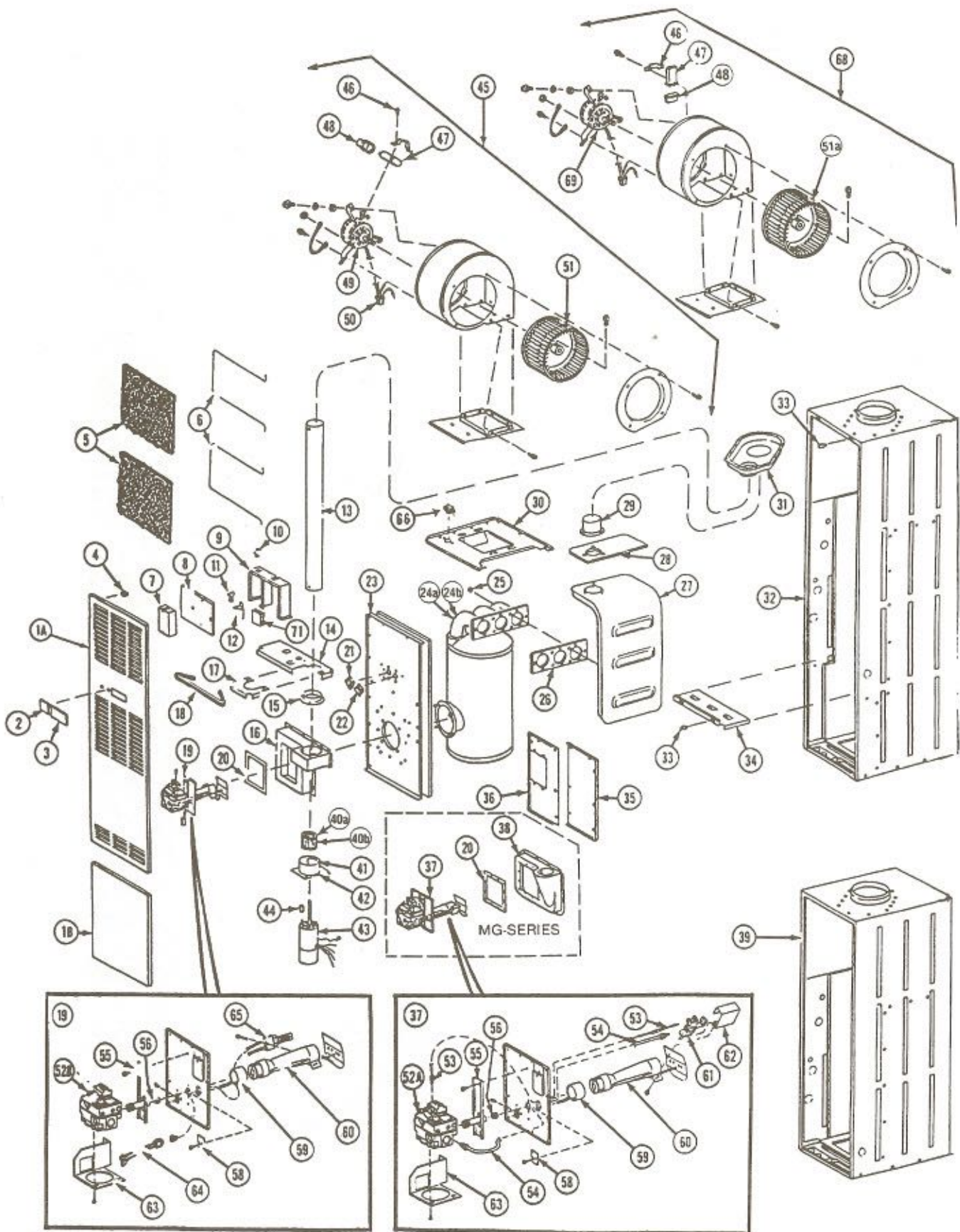

**MG(-)A and MM(-)A SERIES GAS FURNACE PARTS LIST**

ITEM NO	PART NUMBER	DESCRIPTION	MG(-)A MODELS					MM(-)A MODELS			
			-056	-066	-075	-090	-090PQ	-056	-066	-075	-090
1A	902004	Louvered Door (Includes 2-Door Latches)	1	1	1	1	1	1	1	1	1
1B	902005	Coil Door (AB Model) Includes 2-Door Latch	1	1	1	1	1	1	1	1	1
2	687013-	Name Plate (Miller)	1	1	1	1	1	1	1	1	1
	687012-	Name Plate (Intertherm)	1	1	1	1	1	1	1	1	1
3	668772-	Decorative Door Insert	1	1	1	1	1	1	1	1	1
4	668420-	Door Latch-(2 required)	1	1	1	1	1	1	1	1	1
*5	668780-	Air Filter	1	1	1	1	1	1	1	1	1
6	668788-	Air Filter Retainer	1	1	1	1	1	1	1	1	1
7	626333-	HSI Control						1	1	1	1
8	246710-	Control Box Cover	1	1	1	1	1	1	1	1	1
9	355390-	Control Box	1	1	1	1	1	1	1	1	1
*10	631947-	SPDT. Switch	1	1	1	1	1	1	1	1	1
11	631728-	Cap Pin	1	1	1	1	1	1	1	1	1
*12	621094-	Transformer	1	1	1	1	1				
	621096-	Transformer						1	1	1	1
13	356271-	Fresh Air Pipe 4"	1	1	1	1	1	1	1	1	1
14	355500-	Shelf Divider	1	1	1	1	1	1	1	1	1
15	246850-	Collar	1	1	1	1	1	1	1	1	1
16	461120-	Lower Air Box				1	1	1	1	1	1
17	247360-	Close-Off Shelf Divider	1	1	1	1	1	1	1	1	1
18	688877-	Tape, Foam	1	1	1	1	1	1	1	1	1
19	902006	Burner HSI/56-90,000 (Less Main Orifice)						1	1	1	1
20	689009-	Valve Gasket	1	1	1	1	1	1	1	1	1
*21	626336-	Limit-160 Deg F Open/40 Deg F Diff	1	1				1	1		
	626341-	Limit-155 Deg F Open/40 Deg F Diff			1	1	1			1	1
*22	626337-	Fan-115 Deg F Close/30 Deg F Diff	1	1	1	1	1	1	1	1	1
23	458230-	Front Air Casing	1	1	1	1	1	1	1	1	1
*24	902032-	Includes 2 Pipe Heat Exchanger Assy.— 464760 plus item 26. gasket	1	1			1	1			
24A	902033-	Includes 3 Pipe Heat Exchanger Assy.— 465020 plus item 26. gasket			1						
24B	902034-	Includes 3 Pipe Heat Exchanger Assy.— 464770 plus item 26. gasket				1				1	1
25	606005-	1/4-20 Nut*	1	1	1	1	1	1	1	1	1
26	689050-	Radiator Plate Gasket	1	1	1	1	1	1	1	1	1
27	902036-	Includes Radiator Assy.—464830 plus items 28, 29 and 26.	1	1	1	1	1	1	1	1	1
28	689012-	Heat Exchanger Insulation	1	1	1	1	1	1	1	1	1
29	355070-	Upper Flue Pipe	1	1	1	1	1	1	1	1	1
30	462570-	Top Air Casing	1	1	1	1	1	1	1	1	1
31	458740-	Upper Air Box	1	1	1	1	1	1	1	1	1
32	458370-	Cabinet (AB Models)	1	1	1	1	1	1	1	1	1
33	668421-	Door Strike-(2 required)	1	1	1	1	1	1	1	1	1
34	355050-	Shelf (AB Models)	1	1	1	1	1	1	1	1	1
35	355490-	Right Coil Close Off (AB Models)	1	1	1	1	1	1	1	1	1
36	355480-	Left Coil Close Off (AB Models)	1	1	1	1	1	1	1	1	1
37	902007	Burner (56,000-90,000) Less Main Orifice	1	1	1	1	1				
38	458750-	Lower Air Box	1	1	1						
39	458360-	Cabinet Assembly	1	1	1	1	1	1	1	1	1
*40A	667186	Wheel, Combustion						1	1		
*40B	667187	Wheel, Combustion					1			1	1
41	355510-	Scroll					1	1	1	1	1
42	355860-	Mounting Plate					1	1	1	1	1
43	621080-	Motor, Combustion					1	1	1	1	1
44	668785-	Grommet						1	1	1	1
45	902008-	Blower Assembly (56,000)	1					1			
	902009-	Blower Assembly (66,000)		1					1		
	902010-	Blower Assembly (75,000)			1					1	
	902011-	Blower Assembly (90,000)				1	1				1
46	118380-	Capacitor Strap				1	1				1
*47	620233-	Capacitor 10 MFD 370V				1	1				1

\* = Part should be stocked by distributor

**MG/MM SERIES GAS FURNACE PARTS LIST**

ITEM NO	PART NUMBER	DESCRIPTION	MGH MODELS					MMH MODELS				
			-056	-066	-075	-090	-090PQ	-056	-066	-075	-090	
48	631330	Capacitor Boot				1	1					1
*49	901872	Motor (56,000)-1/8 HP	1						1			
	901873	Motor (66,000 & 75,000)-1/5 HP		1	1					1	1	
	901874	Motor (90,000)-1/4 HP				1	1					1
50	631724	Circuit Plug	1	1	1	1	1	1	1	1	1	1
*51	667149	Blower Wheel (56,000 & 66,000)-9 x 7	1	1					1	1		
*51A	667037	Blower Wheel (75,000 & 90,000)-10 x 8			1	1	1				1	1
*52A	624491	Gas Valve	1	1	1	1	1					
*52B	624490	Gas Valve (HSI)							1	1	1	1
*53	631132	Thermocouple	1	1	1	1	1					
54	247620	Pilot Tube	1	1	1	1	1					
55	247690	Spud Plate	1	1	1	1	1	1	1	1	1	1
*56	660615	Natural Gas Orifice (56,000) Drill # 29	1						1			
	660580	Natural Gas Orifice (66,000) Drill # 26		1						1		
	660581	Natural Gas Orifice (75,000) Drill # 22			1						1	
	660582	Natural Gas Orifice (90,000) Drill # 17				1	1					1
	660583	LPG Orifice (56,000) (Not Shown) Drill # 45	1						1			
	660584	LPG Orifice (66,000) (Not Shown) Drill # 43		1						1		
	660585	LPG Orifice (75,000) (Not Shown) Drill # 41			1						1	
	660586	LPG Orifice (90,000) (Not Shown) Drill # 36				1	1					1
57	247650	Burner Plate	1	1	1	1	1	1	1	1	1	1
58	247640	Tube Cover	1	1	1	1	1	1	1	1	1	1
59	247660	Air Shutter	1	1	1	1	1	1	1	1	1	1
60	356140	Venturi	1	1	1	1	1	1	1	1	1	1
61	660575	Pilot Burner	1	1	1	1	1					
62	247630	Pilot Shield	1	1	1	1	1					
63	247610	Valve Support	1	1	1	1	1	1	1	1	1	1
64	250030	Ignitor Pin Plug							1	1	1	1
*65	632088	Ignitor							1	1	1	1
66	626340	Limit-140° Open/Manual Reset	1	1	1	1	1	1	1	1	1	1
67	618020	Pilot Lighter Rod (Not Shown)	1	1	1	1	1					
68	901998	Complete Blower, 1.5-3.5 Ton Cooling, Multi-Sp, Includes items (46,47,48,69,51A)	1	1	1	1	1	1	1	1	1	1
*69	901875	Motor-1/3 HP	1	1	1	1	1	1	1	1	1	1
70	901997	Manual Electric Ignition (opt)-Not Shown	1	1	1	1						
*71	660190	Relay					1					

\* = Part should be stocked by distributor

7067092 0391 (Replaces 7067091 0990)

St Louis, MO

**NORDYNE**  
A NORTH AVON COMPANY

Specifications and illustrations subject to change without notice and without incurring obligations. Printed in U.S.A.



# Installation Instructions

For Models:  
 MGHA-090-AAPQ01, MGHA-090-ABPQ01  
 and MGBA-090-ABPQ01

These models have a standing pilot and an induced draft blower. The induced draft blower and blower relay are the only differences between these models and the standard standing pilot models. The installation procedure and operating instructions for these models are included in the installation instructions and the owner's information documents. Follow the Lighting Instructions for Standing Pilot Models.

## INSTALLATION SEQUENCE for models with Standing Pilot and Induced Draft Blowers.

1. On a call for heat, the thermostat contacts close, supplying 24 VAC to the relay module.
2. The relay contacts close and energize the induced draft motor.
3. When the motor reaches approximately 80% of full speed the proving switch closes and energizes the gas valve.
4. When the gas valve is energized it steps open at a reduced flow and opens fully after approximately 15 seconds.
5. When the call for heat is satisfied the thermostat contacts open, the gas valve closes, and the induced draft blower stops.

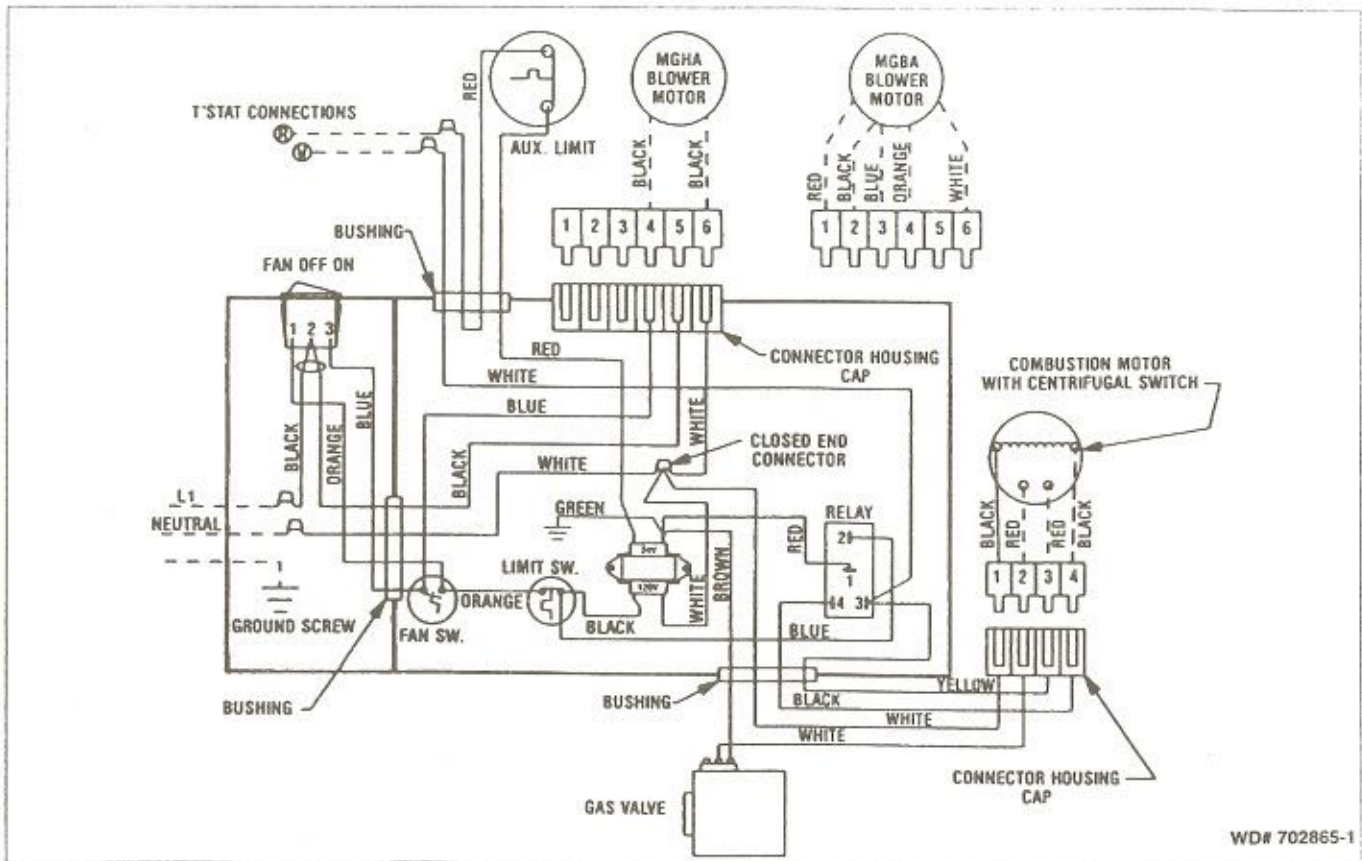

Wiring Diagram - Gas Standing Pilot with Induced Draft Motor