

# Packaged Cooling & Gas/Electric Rooftops

---

## Convertible

*3-10 Tons — 60 Hz*



**Packaged Cooling (T\*C)**



**Packaged Gas/Electric (Y\*C)**

# Introduction

---

## Packaged Rooftop Air Conditioners

Through the years, American Standard has designed and developed the most complete line of Packaged Rooftop products available in the market today. American Standard was the first to introduce the Micro—microelectronic unit controls—and has continued to improve and revolutionize this design concept.

Electromechanical controls are available for simpler applications, and for the more sophisticated, ReliaTel™ microprocessor controls.

The ReliaTel control platform offers the same great features and functionality as the original Micro, with additional benefits for greater application flexibility.

With its sleek, compact cabinet, rounded corners and beveled top the Convertible unit continues to provide the highest standards in quality and reliability, comfort, ease of service, and the performance of American Standard light commercial products.

American Standard customers demand products that provide exceptional reliability, meet stringent performance requirements, and are competitively priced.

The Convertible unit features cutting edge technologies: reliable compressors, American Standard engineered ReliaTel controls and computer-aided run testing. So, whether you're the contractor, the engineer, or the owner you can be certain Convertible Products are built to meet your needs.

American Standard - New Standards for Living.



## Packaged Cooling



## Packaged Gas/Electric

# **Contents**

---

<b>Introduction</b> . . . . .	<b>2</b>
<b>Features and Benefits</b> . . . . .	<b>4</b>
<b>Application Considerations</b> . . . . .	<b>10</b>
<b>Selection Procedure</b> . . . . .	<b>11</b>
<b>Model Number Description</b> . . . . .	<b>13</b>
<b>General Data</b> . . . . .	<b>15</b>
<b>Performance Data</b> . . . . .	<b>29</b>
<b>Controls</b> . . . . .	<b>105</b>
<b>Electrical Data</b> . . . . .	<b>107</b>
<b>Jobsite Connections</b> . . . . .	<b>117</b>
<b>Dimensional Data</b> . . . . .	<b>118</b>
<b>Weights</b> . . . . .	<b>126</b>
<b>Mechanical Specifications</b> . . . . .	<b>128</b>

## Features and Benefits

---

### Standard Features

- 1" throwaway filters provided on 3-5 ton units
- 2" throwaway filters provided on 6-10 ton units
- 5-year Limited Compressor Warranty
- 5-year Limited Heat Exchanger Warranty
- 1-year Limited Parts Warranty
- Anti-Short Cycle Timer (Standard with ReliaTel™)
- Belt Drive Motors (6-10 tons)
- Colored and Numbered Wiring
- Convertible Airflow
- Direct Drive Motors (3-5 tons)
- Easy Access Low Voltage Terminal Board (LTB)
- Electromechanical or ReliaTel Microprocessor Controls
- Foil-Faced and Edge Captured Insulation
- IAQ Dual Sloped and Removable Drain Pans
- Liquid Line Refrigerant Drier
- Low Ambient Cooling to 0°F on Microprocessor Models
- Low Ambient Cooling to 40°F on Electromechanical Models
- Operating Charge of R-22
- Patented Hybrid Condenser Coil for easy cleaning
- Progressive Tubular Aluminized Steel Heat Exchanger
- Provisions for Through-the-Base Gas and Condensate Drain Connections
- Quick Access Panels
- Quick Adjust Fan Motor Mounting Plate
- Single Point Power
- Single Side Service
- Standardized Components

- American Standard built Scroll Compressors on all 3-10 ton units except 3 ton Standard Efficiency Model (Reciprocating Compressor)

### Options\*

#### Factory Installed Options

- Belt Drive Motors (3-5 tons)
- Black Epoxy Pre-Coated Coils
- CompleteCoat™ Condenser Coil
- Dehumidification Option
- High Pressure Cutout
- Hinged Access Doors
- Novar Return Air Sensor
- Novar Unit Controls
- Phase Monitor
- Powered or Unpowered Convenience Outlet
- Stainless Steel Heat Exchanger with 10-year warranty
- Supply and/or Return Air Smoke Detector
- Thermal Expansion Valve
- Through the Base Electrical Access
- Through the Base Electrical with Circuit Breaker
- Through the Base Electrical with Disconnect Switch
- 2" Pleated Filters

#### Factory or Field Installed Options

- Barometric Relief
- Clogged Filter/Fan Failure Switch
- Crankcase Heaters
- Discharge Air Sensing Kit
- Economizer
- Electric Heaters
- Froststat
- Oversized Motors
- Reference or Comparative Enthalpy
- Tool-less Hail Guards

### Field Installed Options

- CO<sub>2</sub> Sensing
- Digital Display Zone Sensor
- Dual Thermistor Remote Zone Sensor
- High Altitude Kit
- High Static Drive
- Humidity Sensor
- LP Conversion Kit
- Manual Outside Air Damper
- Motorized Outside Air Dampers
- Powered Exhaust
- Quick Adapt Curbs
- Quick Start Kit
- Remote Potentiometer
- Roof Curb
- Thermostat
- Ventilation Override Accessory
- Zone Sensor

**\*Refer to Model Number Description for option availability.**

### Other Benefits

- Cabinet design ensures water integrity
- Ease of Service, Installation and Maintenance
- Mixed model build enables "fastest in the industry" ship cycle times
- Outstanding Airflow Distribution
- ReliaTel Controls
- Unmatched Product Support is one of our finest assets. American Standard Sales Representatives are a Support Group that can assist you with:
  - Product
  - Application
  - Service
  - Training
  - Special Applications
  - Specifications
  - Computer Programs and much more

## Features and Benefits

---

### Standard Features

#### Anti-Short Cycle Timer (Standard with ReliaTel)

Provides a 3 minute minimum "ON" time and 3 minute "OFF" time for compressors to enhance compressor reliability by assuring proper oil return.

#### Colored And Numbered Wiring

Save time and money tracing wires and diagnosing the unit.

#### Compressors

The Convertible unit contains the best compressor technology available to achieve the highest possible performance. Our compressor line includes ClimaTuff® reciprocating and scrolls.



#### Condenser Coil

The Convertible unit boasts a patent-pending 1+1+1 condenser coil, permanently gapped for easy cleaning.



#### Controls – ReliaTel or Electromechanical

ReliaTel microprocessor controls provide unit control for heating, cooling and ventilating utilizing input from sensors that measure indoor and outdoor temperature and other zone sensors. ReliaTel also provides outputs for building automation systems and expanded diagnostics. For a complete list of ReliaTel offerings, refer to the "Other Benefits" section within the Features and Benefits section of this catalog.

For the simpler job that does not require a building automation system, or expanded diagnostics capabilities, the Convertible unit offers electromechanical controls. This 24-volt control includes the control transformer and contactor pressure lugs for power wiring.

#### Convertible Units

The units ship in a downflow configuration. They can be easily converted to horizontal by simply moving two panels.

Units come complete with horizontal duct flanges so the contractor doesn't have to field fabricate them. These duct flanges are a time and cost saver.



#### Cooling

Standard or High Efficiency Cooling available.

#### Dual Sloped Drain Pans

Every unit has a non-corrosive, removable, double-sloped drain pan that's easy to clean and reversible to allow installation of drain trap on either side of the unit.



#### Easy Access Low Voltage Terminal Board

The Low Voltage Terminal Board is external to the electrical control cabinet. It is extremely easy to locate and attach the thermostat wire and test operation of all unit functions. This is another cost and time saving installation feature.

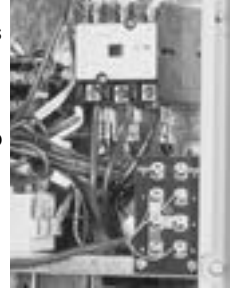

#### Foil Faced Insulation

All panels in the evaporator section of the unit have cleanable foil-faced insulation. All edges are either captured or sealed to ensure no insulation fibers get into the airstream.

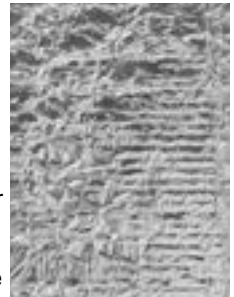

#### Heat Exchanger

The compact cabinet features a progressive tubular heat exchanger in low, medium and high heat capacities.

The heat exchanger is fabricated using stainless steel burners and corrosion-resistant aluminized steel tubes as standard on all models. It has an induced draft blower to pull the gas mixture through the burner tubes. The heater has a direct spark ignition system which doubles as a safety device to prove the flame.

Gas/Electric models exceed all California seasonal efficiency requirements. They also perform better than required to meet the California NOx emission requirements.

#### Low Ambient Cooling

All microprocessor units have cooling capabilities down to 0°F as standard. Electromechanical models have cooling capabilities to 40°F as built, or to 0°F by adding the optional low ambient control (froststat).

## Features and Benefits

---

### Low Voltage Connections

The wiring of the low voltage connections to the unit and the zone sensors is as simple as 1-1, 2-2, and 3-3. This simplified system makes it easy for the installer to wire.

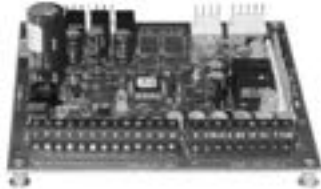

### Motors

Belt or direct drive – standard or oversized supply fan motors meet a wide airflow range.

### Quick-Access Panels

Remove two screws for access to the standardized internal components and wiring.

### Quick-Adjust Idler Arm

With the Quick-Adjust Idler Arm, the belt and sheaves can be quickly adjusted without moving the mounted fan motor. The result is a major savings in time and money.

### Single Point Power

A single electrical connection powers the unit.

### Single Side Service

Single side service is standard on all units.

### Standardized Components

Components are placed in the same location on all Convertible units. Familiarize yourself with one Convertible unit and you are familiar with every Convertible unit.

Due to standardized components throughout the line, contractors/owners can stock fewer parts.

### Through the Base Condensate

Every unit includes provisions for through the base condensate drain connections. This allows the drain to be connected through the roof curb instead of a roof penetration.

## Variety of Options\*

### Factory Installed Options

#### Belt Drive Motors (3-5 tons)



For additional static requirements, 3-5 ton units offer an optional belt drive motor to meet a wide range of airflow needs.

#### Black Epoxy Pre-Coated Coils

The pre-coated coils are an economical option for protection in mildly corrosive environments.

#### CompleteCoat™ Condenser Coil

These coils provide excellent corrosion resistance as well as uniformity of coverage and coating thickness.

#### Circuit Breaker (Required with Through-the-Base Electrical)

This option is a factory installed thermal magnetic, molded case, HACR Circuit Breaker with provisions for through the base electrical connections.



#### Disconnect Switch (Required with Through-the-Base Electrical)

Factory installed 3-pole, molded case, disconnect switch with provisions for through the base electrical connections are available.

Codes require a method of assured unit shutdown for servicing. Field-installed disconnects sometimes interfere with service access. Factory installation of unit disconnects reduces costs, assures proper mounting and provides the opportunity to upgrade to unit circuit breaker protection.

#### Dehumidification (Hot Gas Reheat) Option

This option allows for increased outdoor air ventilation. It reduces humidity levels while increasing comfort



level in the air space. Cooling can operate without a demand for dehumidification. The hot gas reheat coil is designed to deliver maximum reheat temperatures and pivot to allow for easy access cleaning.

#### High Pressure Cutout

This factory-installed option is offered for units that do not have High Pressure Cutout as standard. All 3-phase units with scroll compressors include High Pressure cutout as standard.

#### Hinged Access Doors

These doors permit easy access to the filter, fan/heat, and compressor/control sections. They reduce the potential roof damage from screws or sharp access door corners.



#### Novar Unit Controls

Novar 3051 and 2024 are available for Gas and Electric Heat models.

#### Phase Monitor

Phase monitor shall provide 100% protection for motors and compressors against problems caused by phase loss, phase imbalance, and phase reversal. Phase monitor is equipped with an LED that provides an ON or FAULT indicator.

***\*Refer to Model Number Description for option availability.***

## Features and Benefits

---

### Powered or Unpowered Convenience Outlet

This option is a GFCI, 120v/15amp, 2 plug, convenience outlet, either powered or unpowered. This option can only be ordered when Through the Base Electrical with either the Disconnect Switch or Circuit Breaker option is ordered.



### Stainless Steel Heat Exchanger

The optional stainless steel heat exchanger is constructed of 304 stainless steel. It is resistant to corrosion and oxidation and easy to clean.

The high strength to weight ratio allows for high ventilation rates with gas units. It is an excellent option to compliment the dehumidification option as a high outside air ventilation unit.

With this option, a 10-year stainless steel heat exchanger warranty is standard.

### Supply and/or Return Air Smoke Detector



With this option installed, if smoke is detected, all unit operation will be shut down. Reset will be manual at the unit. Return Air Smoke Detectors require minimum allowable airflow when used with certain models.

### Thermal Expansion Valve

Available for a wider range of applications.

### Through-the-Base Electrical Utility Access

An electrical service entrance shall be provided allowing electrical access for both control and main power connections inside the curb and through the base of the unit. Option will allow for field installation of liquid-tight conduit and an external field installed disconnect switch.



Factory provided through the base openings simplify wiring and piping.

Because these utility openings frequently minimize the number of roof penetrations, the integrity of roofing materials is enhanced.



### Two-Inch Pleated Filters

2" pleated media filters are offered as an option on all units for jobs with enhanced Indoor Air Quality (IAQ) requirements.

### Factory or Field Installed Options

#### Barometric Relief

Designed to be used on downflow units, barometric relief is an unpowered means of relieving excess building pressure.

#### Clogged Filter/Fan Failure Switch

A dedicated differential pressure switch is available to achieve active fan failure indication and/or clogged filter indication.

These sensors allow a zone sensor service light to indicate a dirty filter or a fan that's not working. The field installation charges for these valuable feedback devices often eliminate them from consideration. Factory installation can make such features a good investment.

### Crankcase Heaters

These band or insertion heaters provide improved compressor reliability by warming the oil to prevent migration during off-cycles or low ambient conditions.

### Discharge Air Sensing Kit

Provides true discharge air sensing in heating models. The kit is functional only with the ReliaTel Options Module.

### Electric Heaters

Electric heat modules are available within the basic unit. If ordering the Through the Base Electrical option with an Electrical Heater, the heater must be factory installed.

### Fresh Air Options – Dampers and Economizer

0 - 25% manual or 0 - 50% motorized outside air hoods are available.

Economizers are equipped with either dry bulb or reference or comparative enthalpy sensing. These economizers provide free cooling as the outdoor temperature and/or humidity decreases. Correctly installed, they offer a valuable energy savings. Factory-installed economizers save time and ensure proper installation.

The economizers come with three control options — dry bulb is standard, enthalpy and differential enthalpy are optional.

### Frostat

This capillary bulb embedded in the face of the evaporator coil monitors coil temperature to prevent evaporator icing and protect the compressor. Recommended for applications with low leaving air temperatures, low airflow and or high latent load applications.

### Oversized Motors

Factory or field installed oversized motors available for high static applications.

## Features and Benefits

---

### Reference or Comparative Enthalpy

Measures and communicates humidity while maximizing comfort control.

### Tool-less Hail Guards

Tool-less, hail protection quality coil guards shall be either factory or field-installed for condenser coil protection. This option protects the condenser coil from vandalism and/or hail damage.



### Field Installed Options

#### CO<sub>2</sub> Sensing

The CO<sub>2</sub> sensor has the ability to monitor space occupancy levels within the building by measuring the parts per million of CO<sub>2</sub> (Carbon Dioxide) in the air. As the CO<sub>2</sub> levels increase, the outside air damper modulates to meet the CO<sub>2</sub> space ventilation requirements. The CO<sub>2</sub> sensor kit is available as a field installed accessory.

#### Digital Display Zone Sensor

The Digital LCD (Liquid Crystal Display) zone sensor has the look and functionality of standard zone sensors. This sensor should be utilized with ReliaTel™ controls.

#### Dual Thermistor Remote Zone Sensor

This sensor will reduce the total number of remote sensors to obtain space temperature averaging. This sensor should be utilized with ReliaTel controls.

#### High Altitude Kit

Previously a Canadian Agency requirement for units applied about 2000 feet, it is not required by the U.S. Domestic contractors should consult with local authority on best practice. Deviates gas orifices by 10%.

### High Static Drive

Available on many models, this high static drive accessory extends the capability of the standard motor. Avoid expensive motors and operating costs by installing this optimized sheave accessory.

### Humidity Sensor/Humidistat

Used in conjunction with our Dehumidification (Hot Gas Reheat) units to provide outstanding humidity control and comfort. Humidity sensors can be wall or duct mounted and set for levels between 40% and 60%.

### LP Conversion Kit

Provided for field conversion of gas/electric units from Natural gas to Propane.

### Powered Exhaust Option

This option is available on downflow units and provides exhaust of the return air, when using a downflow economizer, to maintain proper building pressurization. Great for relieving most building overpressurization problems.

### Quick Adapt Curbs

Enables easy conversion of existing Dedicated 3-10 ton units to Convertible units on replacement jobs.

### Quick Start Kits

Single phase equipment to enable startup and prevent building lighting dimming during low voltage.

### Roof Curbs

Available for downflow units. Only two roof curbs for the entire line simplifies curb selection.

### Remote Potentiometer

When properly installed in the economizer control circuitry, this accessory provides a remote variable resistance to enable the operator to adjust the minimum damper position.

### Ventilation Override Accessory

With the Ventilation Override Accessory installed, the unit can be set to transition to up to 3 different pre-programmed sequences for Smoke Purge, Pressurization, and Exhaust. The transition occurs when a binary input on the RTOM is closed (shorted). This would typically be a hard wired relay output from a smoke detector or fire control panel. The ventilation override kit is available as a field installed accessory.

### Zone Sensors/Thermostats

Available in programmable, automatic and manual styles.

## Other Benefits

### Airflow Distribution

Airflow is outstanding. The Convertible unit can replace an older machine with old ductwork and, in many cases, improve the comfort through better air distribution.

### Cabinet Integrity

For added water integrity, the Convertible unit has a raised 1 1/8" lip around the supply and return of the downflow units to prevent water from blowing into the ductwork.



### Easy to Install, Service and Maintain

Because today's owners are very cost-conscious when it comes to service and maintenance, the American Standard Convertible unit was designed with direct input from service contractors. This valuable information helped to design a product that would get the serviceman off the job quicker and save the owner money. The Convertible unit does this by offering outstanding standard features



## Features and Benefits

---

enhanced by a variety of factory and field installed options, multiple control options, rigorously tested proven designs and superior product and technical support.

### Flexibility

The Convertible unit offers ultimate flexibility. Units are built to order in our standard "shortest in the industry" ship cycle time.

### Unit Cabinet

The compact cabinet with rounded corners takes up less room and is less costly to ship. The beveled and ribbed top is not only aesthetically pleasing, it is designed to prevent water from pooling.

### ReliaTel™ Controls

ReliaTel controls provide unit control for heating, cooling and ventilating utilizing input from sensors that measure outdoor and indoor temperature.

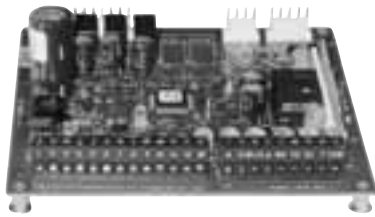

### ReliaTel Control Logic Enhances Quality and Reliability

- —prevents the unit from short cycling, considerably improving compressor life.
- —ensures that the compressor will run for a specific amount of time which allows oil to return for better lubrication, enhancing the reliability of the compressor.

The Convertible unit with ReliaTel reduces the number of components required to operate the unit, thereby reducing possibilities for component failure.

### ReliaTel Makes Installing and Servicing Easy

ReliaTel eliminates the need for field installed anti-shortcycle timer and time delay relays. ReliaTel controls provide these functions as an integral part of the unit. The contractor no longer has to purchase these controls as options and pay to install them.



The wiring of the low voltage connections to the unit and the zone sensors is as easy as 1-1, 2-2, and 3-3. This simplified system makes wiring easier for the installer.

### ReliaTel Makes Testing Easy

ReliaTel requires no special tools to run the unit through its paces. Simply place a jumper between Test 1 and Test 2 terminals on the Low Voltage Terminal Board and the unit will walk through its operational steps automatically.

The unit automatically returns control to the zone sensor after stepping through the test mode a single time, even if the jumper is left on the unit.

As long as the unit has power and the "system on" LED is lit, ReliaTel is operational. The light indicates that the controls are functioning properly.

Some zone sensor options have central control panel lights which indicate the mode the unit is in and possible diagnostic information (dirty filters for example).

### Other ReliaTel Benefits

The ReliaTel built-in anti-shortcycle timer, time delay relay and minimum "on" time control functions are factory tested to assure proper operation.

ReliaTel softens electrical "spikes" by staging on fans, compressors and heaters.

Intelligent Fallback is a benefit to the building occupant. If a component goes astray, the unit will continue to operate at predetermined temperature setpoint.

Intelligent Anticipation is a standard ReliaTel feature. It functions continuously as ReliaTel and zone sensor(s) work together in harmony to provide much tighter comfort control than conventional electro-mechanical thermostats.

The same ReliaTel Board fits all Convertible Packaged Gas/Electrics, Cooling with Electric Heat, and Heat Pump models. This provides standardization of parts for contractors. Less money is tied up in inventory with ReliaTel.

### Rigorous Testing

All of the Convertible unit's designs were rigorously rain tested at the factory to ensure water integrity.

Actual shipping tests were performed to determine packaging requirements. Units were test shipped around the country to determine the best packaging. Factory shake and drop tests were used as part of the package design process to help assure that the unit arrives at the job site in top condition.

Rigging tests include lifting a unit into the air and letting it drop one foot, assuring that the lifting lugs and rails hold up under stress.

We perform a 100% coil leak test at the factory. The evaporator and condenser coils are leak tested at 200 psig and pressure tested to 450 psig.

All parts are inspected at the point of final assembly. Sub-standard parts are identified and rejected immediately.

Every unit receives a 100% unit run test before leaving the production line to make sure it lives up to rigorous American Standard requirements.

# Application Considerations

---

Application of this product should be within the cataloged airflow and cooling considerations.

## Barometric Relief

This product line offers an optional barometric relief damper for use in conjunction with economizer option. This accessory consists of gravity dampers which open with increased pressure. As the building air pressure increases, the pressure in the unit return air section also increases, opening the dampers and relieving the conditioned space.

**Note:** *The effectiveness of barometric relief damper during economizing operation is system related.*

**Note:** *Pressure drop of the return air system should be considered to control building pressurization.*

## Black Epoxy Coil

The coils are manufactured with a thermoset, vinyl coating that is bonded to the aluminum fin stock prior to the fin stamping process. These coils are an economical option for protection in mildly corrosive environments.

**Note:** *Not to be used where seacoast applications exist.*

## CompleteCoat™ Condenser Coil

The coils provide protection from corrosive environments and is ideal for seacoast applications.

## Clearance Requirements

The recommended clearances identified with unit dimensions should be maintained to assure adequate service maximum capacity and peak operating efficiency. Actual clearances which appear inadequate should be reviewed with the local American Standard sales personnel.

## Condensate Trap

The evaporator is a draw-thru configuration. A trap must be field provided prior to start-up on the cooling cycle.

## Heating Operation

The heat exchanger is manufactured with aluminized steel. To prevent condensation within the heat exchanger, do not exceed 50% outside air or a minimum mixed air temperature of 40°F.

## Optional Stainless Steel Heat Exchanger

The optional stainless steel heat exchanger is manufactured with 304 stainless steel. To prevent corrosion and prolong heat exchanger reliability, the minimum mixed air temperature allowed across the heat exchanger is 20°F.

The stainless steel heat exchanger option is an excellent option that compliments the dehumidification package. Whenever high outside air or outside applications exist, these options should be utilized.

## Low Ambient Cooling

The line features, with ReliaTel™ microprocessor controls, low ambient cooling down to 0°F. With electromechanical controls, the Convertible unit features low ambient cooling to 40°F. The following options need to be included/considered when low ambient applications are required: continuous fan operation, crankcase heaters, thermal expansion valves, frostat.

Contact your local American Standard Representative for more assistance with low ambient cooling applications.

## Unit Pitch

These units have reversible sloped condensate drain pans. Units must be installed level. Any unit slope must be toward the side of unit where condensate drain is connected.

# Selection Procedure

## Cooling Capacity

**Note:** Cooling Capacity Procedure is the same for electric heat (T\_C) and gas heat (Y\_C).

### Step 1.

Calculate the building's total and sensible cooling loads at design conditions. Use the American Standard calculation methods or any other standard accepted method.

Factors used in unit selection:

Packaged Cooling with Electric Heat  
 Total Cooling Load: 59 MBh  
 Sensible Cooling Load: 40 MBh  
 Airflow: 2000 cfm  
 Electrical Characteristics: 460/60/3  
 Summer Design Conditions:  
 Entering Evaporator Coil: 80 DB, 67 WB Outdoor Ambient: 95  
 External Static Pressure: 0.36 in. wg  
 Downflow Configuration  
 High Efficiency  
 Economizer  
 TXV's

### Step 2.

As a starting point, a rough determination must be made of the size of the unit. The final selection will be made after examining the performance at the given conditions. Divide the total cooling load by nominal BTUH per ton (12 MBh per ton); then round up to the nearest unit size.

59 MBh / 12 MBh = approx. 5 tons

### Step 3.

Table 10 shows that a TSC060A4 has a **gross** cooling capacity of 63 MBh and 48.2 MBh sensible capacity at 2000 cfm and 95 DB outdoor ambient with 80 DB, 67 WB air entering the evaporator.

### To Find Capacity at Intermediate Conditions Not in the Table.

When the design conditions are between two numbers that are in the capacity table, interpolation is required to approximate the capacity.

**Note:** Extrapolation outside of the table conditions is not recommended.

### Step 4.

In order to select the correct unit which meets the building's requirements, the fan motor heat must be deducted from the gross cooling capacity. The amount of heat that the fan motor generates is dependent on the effort by the motor - cfm and static pressure. To determine the total unit static pressure:

External Static Duct System	0.36 wg
Standard Filter 1 in. from Table 128	0.15 wg
Economizer from Table 128 (100% Outside Air) *worst case	0.18 wg
Electric Heater Size 6 kW from Table 128 (reference "Heating Capacity" section on this page for determination of heater size)	0.056 wg
Total Static Pressure	0.56 wg

**Note:** The Evaporator Fan Performance Table 41 has deducted the pressure drop for a 1 in. filter already in the unit (see note below Table 41). Therefore, the actual total static pressure is 0.75 - 0.15 (from Table 128) = 0.60 wg.

With 2000 cfm and 0.60 wg. Table 41 shows .96 bhp for this unit. Note below the table gives a formula to calculate Fan Motor Heat, 2.829 x bhp + .4024 = MBh. 2.829 x .90 + .4024 = 3.12 MBh.

Now subtract the fan motor heat from the gross cooling capacity of the unit:

**Net** Total Cooling Capacity = 63.1 MBh - 3.12 = 59.98 MBh.

**Net** Sensible Cooling Capacity = 48.2 MBh - 3.12 = 45.08 MBh.

Subtracting Sensible from Total Capacity to find Latent Capacity

**Net** Latent Capacity = 59.98 - 45.08 = 14.90 MBh

### Step 5.

Compare your resulting capacities to the building load. If the performance will not meet the required load of the

building's total or sensible cooling load, try a selection at the next higher size unit.

## Heating Capacity

**Note:** Heating capacity procedure DIFFERS for electric heat (T\_C) and gas heat (Y\_C) units.)

### Step 1.

Calculate the building heating load using the American Standard calculation form or other standard accepted method.

### Step 2.

Size the system heating capacity to match the calculated building heating load. The following are building heating requirements: Total heating load of 30 MBh 2000 cfm

TSC units with electric heat: 460 volt/ 3 phase Power Supply

The electric heat accessory capacities are listed in Table 130. From the table, a 12 kW heater will deliver 40.97 MBh at 480 volts. In order to determine capacity at 460 volts, the heater voltage correction factor from Table 131 or the formula in the notes below table 131 must be used. Therefore, 40.97 MBh x .918 (voltage correction factor) = 37.61 MBh.

YSC units with gas heat: Fuel-natural gas.

60 MBh, 80 MBh and 130 MBh input models shown in Table 129. The output capacities of these furnaces are 48 MBh, 64 MBh and 104 MBh respectively. The low heat model with 48 MBh best matches the building requirements.

## Air Delivery Selection

**Note:** Air Delivery procedure is the same for electric heat (T\_C) and gas heat (Y\_C) units.)

External static pressure drop through the air distribution system has been calculated to be 0.60 inches of water. Enter Table 41 for a TSC060A4 at 2000 cfm and 0.60 static pressure. The standard belt drive motor will give the desired airflow at a rated bhp of 0.96 and 1035 rpm.

## Selection Procedure

### Dehumidification Selection

**Note:** Dehumidification selection procedure is the same for both electric heat (THC) and gas heat (YHC) models.

Typical 5 ton THC063A

1000 cfm Total Supply airflow  
 400 cfm Outside Air (40%)  
 600 cfm Return Air  
 0.34" External Static Pressure

OA Conditions

Part load day and raining

68°F db

67°F wb

95% RH

RA conditions

75°F db

63°F wb

#### Step 1:

Determine the mixed/entering air condition (MA)

$MA = (\% \text{ outside air} * \text{outside air dry-bulb temperature}) + (\% \text{ return air} * \text{return air dry-bulb temperature})$

$MA = (0.40 * 68^\circ F) + (0.60 * 75^\circ F)$

MA = 72.20°F db

**Note:** Repeat for wet-bulb temperature (wb).

Plot on psychrometric chart.

MA

72.2°F db

65°F wb

#### Step 2:

Determine the additional static pressure drop for a reheat unit

Table 128 shows a static pressure drop of 0.03" for the reheat coil and an additional 0.04 for the mandatory 2" pleated filters required when ordering the dehumidification option. Total static pressure =

.34 + 0.04 + 0.02 = 0.41

Do not forget to also add any additional static from other accessories. This selection does not include additional accessories.

Table 91 (airflow table for 5 ton downflow unit) indicates that a standard motor and drive is needed for this airflow and static pressure range.

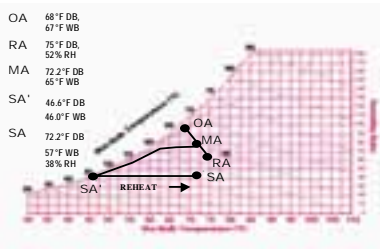

Figure 1. Psychrometric Chart

#### Step 3a:

Determine leaving evaporator temperature (SA')

Leaving Evaporator Temperature = SA'

Utilizing the manual **Cooling Capacity** selection method as previously described, find the leaving evaporator temperatures with the formula:

$$\Delta \text{ Temp} = \frac{\text{gross sensible or gross latent cooling capacity in Btuh}}{(\text{cfm}) (1.085)}$$

Subtract your sensible  $\Delta$  temp from the entering db and latent  $\Delta$  temp from the entering wb to determine the leaving evaporator db & wb (temperatures without the addition of fan heat).

46.6 db

46.0 wb

45.4 dp

Connect MA and SA' on psychrometric chart with cooling curve.

#### Step 3b:

Determine leaving unit temperature in standard cooling mode

Repeat Step 3a substituting **net** sensible or latent capacity for **gross** sensible or latent capacity to find the leaving unit temperature including fan heat.

48.9 db

47.0 wb

#### Step 4:

Determine reheat temperature rise

Using the leaving evaporator temp (SA'), go to Table 135 and determine the reheat temperature rise for that particular cfm:  $\approx 23.3^\circ F$  db

**Note:** Reheat temperature rise is based on **supply airflow** and leaving evaporator coil temperature.

#### Step 5:

Determine leaving unit sensible temperature with reheat active (SA)

Reheat temperature (obtained in step 4) + (SA' + fan heat) = SA

(SA' + fan heat) = leaving unit temperature in standard cooling mode from step 3b.

$23.3^\circ F \text{ db} + 48.9^\circ F = 72.2^\circ F \text{ db}$

SA = 72.2°F

Since reheat adds only sensible heat, the dewpoint temperature will remain constant so follow the dewpoint temperature line across the psychrometric chart to find the new wb temperature.

$\approx 57^\circ F \text{ wb}$   
 45.4 dp  
 38% RH

Consider the Psychrometric Chart. If the space relative humidity is equal to or above the space relative humidity setpoint, the Dehumidification option will:

- Energize compressor or both compressors (2 stage compressor units).
- Hot gas reheat valve is energized and hot gas is diverted to the reheat coil.
- Dehumidification/reheat is terminated when space humidity is reduced to 5% below relative humidity setpoint.

At MA air enters the RTU. The RTU filters, cools, and dehumidifies the air as it moves through the evaporator coil. Air leaves the evaporator coil saturated at the preset dew point condition (SA') and is reheated by the hot gas reheat coil to deliver 72°F (SA) supply air to the space.

# Model Number Description

T S C 036 A 3 R B A \*\* C O O O A 1 0 0 0 1 A 1  
 1 2 3 456 7 8 9 10 11 12,13 14 15 16 17 18 19 20 21 22 23 24 25

**DIGIT 1 – UNIT TYPE**

- T DX Cooling
- Y DX Cooling, Gas Heat

**DIGIT 2 – EFFICIENCY**

- S Standard Efficiency
- H High Efficiency<sup>19</sup>

**DIGIT 3 – AIRFLOW**

- C Convertible

**DIGIT 4,5,6 – NOMINAL GROSS COOLING CAPACITY (MBh)**

- 033/036 3 Ton
- 043/048 4 Ton
- 063/060 5 Ton
- 072 6 Ton
- 090 7½ Ton, Single Compressor
- 092 7½ Ton, Dual Compressor
- 102 8½ Ton
- 120 10 Ton

**DIGIT 7 – MAJOR DESIGN SEQUENCE**

- A R-22 Refrigerant

**DIGIT 8 – VOLTAGE SELECTION**

- 3 208-230/60/3
- 4 460/60/3
- W 575/60/3
- K 380/60/3

**DIGIT 9 – UNIT CONTROLS**

- E Electromechanical
- R ReliaTel™ Microprocessor

**DIGIT 10 – HEATING CAPACITY**

**Note:** Sequence may be any letter A through Z, or any digit 1 through 9.

- 0=No Electric Heat J=23 kW (3 phase)
- B=6 kW (3 phase) K=27 kW (3 phase)
- C=9 kW (3 phase) N=36 kW (3 phase)
- E=12 kW (3 phase) P=54 kW (3 phase)
- G=18 kW (3 phase)

**Note:** Applicable to Digit 1, Y models only.

- L Low
- M Medium
- H High
- X Low, Stainless Steel Heat Exchanger

- Y Medium, Stainless Steel Heat Exchanger
- Z High, Stainless Steel Heat Exchanger

**DIGIT 11 – MINOR DESIGN SEQUENCE**

- A First Sequence

**DIGIT 12,13 – SERVICE SEQUENCE**

- \*\* Factory Assigned

**DIGIT 14 – FRESH AIR SELECTION**

- 0 No Fresh Air
- A Manual Outside Air Damper 0-50%<sup>13</sup>
- B Motorized Outside Air Damper 0-50%
- C Economizer, Dry Bulb 0-100% without Barometric Relief<sup>2</sup>
- D Economizer, Dry Bulb 0-100% with Barometric Relief<sup>2</sup>
- E Economizer, Reference Enthalpy 0-100% without Barometric Relief<sup>1,2</sup>
- F Economizer, Reference Enthalpy 0-100% with Barometric Relief<sup>1,2</sup>
- G Economizer, Comparative Enthalpy 0-100% without Barometric Relief<sup>1,2</sup>
- H Economizer, Comparative Enthalpy 0-100% with Barometric Relief<sup>1,2</sup>

**DIGIT 15 - SUPPLY FAN/DRIVE TYPE/MOTOR**

- 0 Standard Drive<sup>17</sup>
- 1 Oversized Motor
- 2 Optional Belt Drive Motor<sup>20</sup>

**DIGIT 16 - HINGED SERVICE ACCESS/FILTERS**

- 0 Standard Panels/Standard Filters
- A Hinged Access Panels/Standard Filters
- B Standard Panels/2" Pleated Filters
- C Hinged Access Panels/2" Pleated Filters

**DIGIT 17 - CONDENSER COIL PROTECTION**

- 0 Standard Coil
- 1 Standard Coil with Hail Guard
- 2 Black Epoxy Pre-Coated Condenser Coil
- 3 Black Epoxy Pre-Coated Condenser Coil with Hail Guard
- 4 CompleteCoat™ Condenser Coil
- 5 CompleteCoat™ Condenser Coil with Hail Guard

**DIGIT 18 - THROUGH THE BASE PROVISIONS**

**Note:** (Applicable to Digit 1, T or Y models)

- 0 No Through the Base Provisions
- A Through the Base Electric<sup>15</sup>

**Note:** (Applicable to Digit 1, Y models only)

- B Through the Base Gas Piping
- C Through the Base Electric and Gas Piping<sup>12</sup>

**DIGIT 19 - DISCONNECT/CIRCUIT BREAKER/PHASE MONITOR (3 PHASE ONLY)**

- 0 No Disconnect/No Circuit Breaker No Phase Monitor
- 1 Unit Mounted Non-Fused Disconnect<sup>15</sup>
- 2 Unit Mounted Circuit Breaker<sup>15</sup>
- 3 Phase Monitor
- 4 Phase Monitor & Non-Fused Disconnect Switch
- 5 Phase Monitor & Circuit Breaker

**DIGIT 20 - CONVENIENCE OUTLET**

- 0 No Convenience Outlet
- A Unpowered Convenience Outlet
- B Powered Convenience Outlet (3 phase only)<sup>3</sup>

**DIGIT 21 - COMMUNICATIONS OPTIONS<sup>1</sup>**

- 0 No Communications Interface
- 3 Novar 2024 Controls
- 4 Novar 3051 Controls

## Model Number Description

---

### **DIGIT 22 - REFRIGERATION SYSTEM OPTION**

- 0 Standard Refrigeration System<sup>4</sup>
- A Thermal Expansion Valve (TXV)
- B Dehumidification (Hot Gas Reheat Coil)<sup>14,18</sup>

### **DIGIT 23 - REFRIGERATION CONTROLS**

- 0 No Refrigeration Control
- 1 High Pressure Control<sup>1,6</sup>
- 2 Froststat<sup>5</sup>
- 3 Crankcase Heater<sup>16</sup>
- 4 High Pressure Control<sup>1,6</sup> and Froststat<sup>5</sup>
- 5 High Pressure Control<sup>1,6</sup> and Crankcase Heater<sup>16</sup>
- 6 Froststat<sup>5</sup> and Crankcase Heater<sup>6,16</sup>
- 7 High Pressure Control<sup>1,6</sup>, Froststat<sup>5</sup> and Crankcase Heater<sup>6,16</sup>

### **DIGIT 24 - SMOKE DETECTOR<sup>1,6,7</sup>**

- 0 No Smoke Detector
- A Return Air Smoke Detector<sup>8,9</sup>
- B Supply Air Smoke Detector
- C Supply and Return Air Smoke Detectors<sup>9</sup>

### **DIGIT 25 - MONITORING CONTROLS<sup>1</sup>**

- 0 No Monitoring Control<sup>10</sup>
- 1 Clogged Filter Switch<sup>10</sup>
- 2 Fan Failure Switch<sup>10</sup>
- 3 Discharge Air Sensing Tube<sup>10</sup>
- 4 Clogged Filter Switch and Fan Fail Switch<sup>10</sup>
- 5 Clogged Filter Switch and Discharge Air Sensing Tube<sup>10</sup>
- 6 Fan Fail Switch and Discharge Air Sensing Tube<sup>10</sup>
- 7 Clogged Filter and Fan Fail Switches and Discharge Air Sensing Tube<sup>10</sup>
- 8 Novar Return Air Sensor<sup>11</sup>

### **Model Number Notes**

- 1. Not available with electro-mechanical unit controls.
- 2. Economizer with Barometric Relief is for downflow configured units only. Order Economizer without Barometric Relief for horizontal configuration. Barometric Relief for horizontal configured units must be ordered as field installed accessory.

- 3. Requires use of Disconnect or Circuit Breaker.
- 4. Standard refrigeration metering device – short orifice.
- 5. Froststat cannot be field installed in electro-mechanical units.
- 6. High Pressure control is standard on 3-phase units with scroll compressors and in 3 ton standard efficiency units.
- 7. Not available with High Temperature Stat accessory.
- 8. The return air smoke detector may not fit up or work properly on the units when used in conjunction with 3rd party accessories such as bolt on heat wheels, economizers and power exhaust. Do not order the return air smoke detectors when using this type of accessory.
- 9. Return Air Smoke Detector cannot be ordered with Novar Controls.
- 10. These options are standard when ordering Novar Controls.
- 11. This option is used when ordering Novar Controls.
- 12. Includes gas piping and shutoff (field assembly required).
- 13. The manual outside air damper will ship factory supplied within the unit, but must be field installed.
- 14. Requires selection of 2" Pleated Filters (option B or C) for Digit 16.
- 15. Through the base electric required when ordering disconnect/circuit breaker options.
- 16. Crankcase heaters are standard on 3 ton standard efficiency and 7.5 ton single compressor units.
- 17. Direct Drive (3-5 tons); Belt Drive (6-10 tons)
- 18. Not available on 6 ton units and all single phase or standard efficiency.
- 19. Available on 6-10 tons only.
- 20. Belt drive standard on 13 SEER, R-22 products.

## General Data

**Table 1. General Data — 3-4 Tons**

	3 Tons	4 Tons
	T/YSC036A3,4,W	T/YSC048A3,4,W
<b>Cooling Performance<sup>(i)</sup></b>		
Gross Cooling Capacity	37,400	49,200
SEER <sup>(ii)</sup>	10.7	10.0
Nominal CFM / ARI Rated CFM	1,200/1,200	1,600/1,600
ARI Net Cooling Capacity	36,000	47,000
Integrated Part Load Value <sup>(iii)</sup>	—	—
System Power (kW)	3.79	5.40
<b>Compressor</b>		
Number/Type	1/Hermetic	1/Scroll
<b>Sound</b>		
Outdoor Sound Rating (dB) <sup>(iv)</sup>	83	82
<b>Outdoor Coil</b>		
Type	Lanced	Lanced
Tube Size (in.)	0.3125	0.3125
Face Area (sq. ft.)	7.19	9.59
Rows/FPI	2/17	1/17
<b>Indoor Coil</b>		
Type	Lanced	Lanced
Tube Size (in.)	0.3125	0.3125
Face Area (sq. ft.)	5.67	6.17
Rows/FPI	2/16	3/16
Refrigerant Control	Short Orifice	Short Orifice
Drain Connection Number/Size (in.)	1¼ NPT	1¼ NPT
<b>Outdoor Fan</b>		
Type	Propeller	Propeller
Number Used/Diameter (in.)	1/22	1/22
Drive Type/No. Speeds	Direct/1	Direct/1
CFM	2,550	3,610
Number Motors/HP	1/0.20	1/0.33
Motor RPM	1,075	1,075
<b>Direct Drive Indoor Fan</b>		
Type	FC Centrifugal	FC Centrifugal
Number Used/Diameter (in.)	1/10x10	1/11x11
Drive Type/Number Speeds	Direct/2	Direct/2
Number Motors	1	1
Motor HP (Standard/Oversized)	0.33/0.50	0.60/0.80
Motor RPM <sup>(v)</sup> (Standard/Oversized)	930/1,100	1,000/1,100
Motor Frame Size (Standard/Oversized)	48/48	48/48
<b>Belt Drive Indoor Fan</b>		
Type	FC Centrifugal	—
Number Used/Diameter (in.)	1/11x11	1/11x11
Drive Type/Number Speeds	Belt/Variable Sheave	—
Number Motors	1	1
Motor HP (Standard/Oversized)	1.00/—	1.00/—
Motor RPM (Standard/Oversized)	1,750/—	1,750/—
Motor Frame Size (Standard/Oversized)	56/—	56/—
<b>Filters<sup>(vi)</sup></b>		
Type Furnished	Throwaway	Throwaway
Number Size Recommended <sup>(vii)</sup>	(2) 20x25x1	(2) 20x25x1
<b>Refrigerant Charge <sup>(viii)</sup></b>		
Pounds of R-22	3.8	3.8

**Table 1. (continued) General Data — 3-4 Tons**

	<b>3 Tons</b>	<b>4 Tons</b>
<b>Heating Performance<sup>(ix)</sup></b>		
<b>(Gas/Electric Only)</b>		
<b>Heating Input</b>		
Low Heat Input (Btu)	60,000	60,000
Mid Heat Input (Btu)	80,000	80,000
High Heat Input (Btu)	120,000	120,000
<b>Heating Output</b>		
Low Heat Input (Btu)	48,000	48,000
Mid Heat Input (Btu)	64,000	64,000
High Heat Input (Btu)	96,000	96,000
<b>AFUE%<sup>(x)</sup></b>		
Low Heat Input (Btu)	81	81
Mid Heat Input (Btu)	81	81
High Heat Input (Btu)	81	81
<b>Steady State Efficiency%</b>		
Low Heat Input (Btu)	81	81
Mid Heat Input (Btu)	81	81
High Heat Input (Btu)	81	81
<b>No. Burners</b>		
Low Heat Input (Btu)	2	2
Mid Heat Input (Btu)	2	2
High Heat Input (Btu)	3	3
<b>No. Stages</b>		
Low Heat Input (Btu)	1	1
Mid Heat Input (Btu)	1	1
High Heat Input (Btu)	1	1
<b>Gas Supply Line Pressure</b>		
Natural (minimum/maximum)	4.5/14.0	4.5/14.0
LP (minimum/maximum)	10.0/14.0	10.0/14.0
<b>Gas Connection Pipe Size (in.)</b>		
Low Heat	1/2	1/2
Mid Heat	1/2	1/2
High Heat	1/2	1/2

- (i) Cooling Performance is rated at 95 F ambient, 80 F entering dry bulb, 67 F entering wet bulb. Gross capacity does not include the effect of fan motor heat. ARI capacity is net and includes the effect of fan motor heat. Units are suitable for operation to ±20% of nominal cfm. Units are certified in accordance with the Unitary Air-Conditioner Equipment certification program, which is based on ARI Standard 210/240 except AK (380V/60 Hz).
- (ii) EER and/or SEER are rated at ARI conditions and in accordance with DOE test procedures.
- (iii) Integrated Part Load Value is rated in accordance with ARI Standard 210/240 or 360. Units are rated at 80° F ambient, 80° F entering dry bulb, and 67° F entering wet bulb at ARI rated cfm.
- (iv) Outdoor Sound Rating shown is tested in accordance with ARI Standard 270. For additional information refer to [Table 127](#).
- (v) T/YSC036A, 3, 4, W motor RPM shown is low speed. High speed RPM is 1,060/1,145.
- (vi) Optional 2" pleated filters also available.
- (vii) 20 x 25 filter on medium and low heat models. 20 x 30 filter on high heat models.
- (viii) Refrigerant charge is an approximate value. For a more precise value, see unit nameplate and service instructions.
- (ix) Heating Performance limit settings and rating data were established and approved under laboratory test conditions using American National Standards Institute standards. Ratings shown are for elevations up to 2000 feet. For elevations above 2000 feet, ratings should be reduced at the rate of 4% for each 1000 feet above sea level. Applicable to Gas/Electric units only.
- (x) AFUE is rated in accordance with DOE test procedures.



**General Data**

*(5-6 Tons Standard Efficiency)*

**Table 2. General Data — 5-6 Tons**

	5 Tons	6 Tons
	T/YSC060A3,4,W,K	T/YSC072A3,4,W,K
<b>Cooling Performance<sup>(i)</sup></b>		
Gross Cooling Capacity	63,100	72,000
SEER <sup>(ii)</sup>	10.20/10.20	(EERonly) 10.3/10.2 <sup>(iv)</sup>
Nominal CFM / ARI Rated CFM	2,000/2,000	2,400/2,100
ARI Net Cooling Capacity	60,000	69,000
Integrated Part Load Value <sup>(iii)</sup>	—	—
System Power (kW)	6.78	6.77
<b>Compressor</b>		
Number/Type	1/Scroll	1/Scroll
<b>Sound</b>		
Outdoor Sound Rating (dB) <sup>(v)</sup>	84	88
<b>Outdoor Coil</b>		
Type	Lanced	Lanced
Tube Size (in.)	0.3125	0.3125
Face Area (sq. ft.)	8.81	13.88
Rows/FPI	2/17	2/17
<b>Indoor Coil</b>		
Type	Lanced	Lanced
Tube Size (in.)	0.3125	0.3125
Face Area (sq. ft.)	5.00	9.89
Rows/FPI	3/16	2/16
Refrigerant Control	Short Orifice	Short Orifice
Drain Connection Number/Size (in.)	1¾ NPT	1¾ NPT
<b>Outdoor Fan</b>		
Type	Propeller	Propeller
Number Used/Diameter (in.)	1/22	1/26
Drive Type/No. Speeds	Direct/1	Direct/1
CFM	3,470	6,100
Number Motors/HP	1/0.33 <sup>(vi)</sup>	1/0.70 <sup>(vii)</sup>
Motor RPM	1,075	1,075
<b>Direct Drive Indoor Fan</b>		
Type	FC Centrifugal	—
Number Used/Diameter (in.) <sup>(viii)</sup>	1/11x11	—
Drive Type/Number Speeds	Direct/2	—
Number Motors	1	—
Motor HP (Standard/Oversized)	0.90/1.00 <sup>(x)</sup>	—
Motor RPM <sup>(ix)</sup> (Standard/Oversized)	985/1,080	—
Motor Frame Size (Standard/Oversized)	48/48	—
<b>Belt Drive Indoor Fan</b>		
Type	FC Centrifugal	FC Centrifugal
Number Used/Diameter (in.)	1/11x11	1/12x12
Drive Type/Number Speeds	Belt/Variable Sheave	Belt/Variable Sheave
Number Motors	1	1
Motor HP (Standard/Oversized)	1.00/—	1.00/2.00 <sup>(xi)</sup>
Motor RPM (Standard/Oversized)	1,750/—	1,750/1,750
Motor Frame Size (Standard/Oversized)	48/—	56/56
<b>Filters<sup>(xii)</sup></b>		
Type Furnished	Throwaway	Throwaway
Number Size Recommended <sup>(xiii)</sup>	(2) 20x25x1	(4) 16x25x2
<b>Refrigerant Charge (Lbs. of R-22)<sup>(xiv)</sup></b>		
Pounds of R-22	4.9	7.1

**Table 2. (continued) General Data — 5-6 Tons**

	<b>5 Tons</b>	<b>6 Tons</b>
<b>Heating Performance<sup>(xv)</sup></b>		
<b>(Gas/Electric Only)</b>		
<b>Heating Input<sup>(xvi)</sup></b>		
Low Heat Input (Btu)	60,000	80,000
Mid <sup>(xvii)</sup> Heat Input (Btu)	80,000	120,000
High Heat Input (Btu)	130,000	150,000/105,000
<b>Heating Output<sup>(xviii)</sup></b>		
Low Heat Input (Btu)	48,000	64,800
Mid Heat Input (Btu)	64,000	97,200/85,000
High Heat Input (Btu)	104,000	121,500
<b>AFUE%<sup>(xix)</sup></b>		
Low Heat Input (Btu)	81	81
Mid Heat Input (Btu)	81	81
High Heat Input (Btu)	80	81
<b>Steady State Efficiency%</b>		
Low Heat Input (Btu)	81	81
Mid Heat Input (Btu)	81	81
High Heat Input (Btu)	80	81
<b>No. Burners</b>		
Low Heat Input (Btu)	2	2
Mid Heat Input (Btu)	2	2
High Heat Input (Btu)	3	3
<b>No. Stages</b>		
Low Heat Input (Btu)	1	1
Mid Heat Input (Btu)	1	1
High Heat Input (Btu)	1	2
<b>Gas Supply Line Pressure</b>		
Natural (minimum/maximum)	4.5/14.0	4.5/14.0
LP (minimum/maximum)	10.0/14.0	10.0/14.0
<b>Gas Connection Pipe Size (in)</b>		
Low Heat	1/2	1/2
Mid Heat	1/2	1/2
High Heat	1/2	3/4

- (i) Cooling Performance is rated at 95 F ambient, 80 F entering dry bulb, 67 F entering wet bulb. Gross capacity does not include the effect of fan motor heat. ARI capacity is net and includes the effect of fan motor heat. Units are suitable for operation to ±20% of nominal cfm. Units are certified in accordance with the Unitary Air-Conditioner Equipment certification program, which is based on ARI Standard 210/240 except AK (380V/60 Hz).
- (ii) SEER is rated at ARI conditions and in accordance with DOE test procedures.
- (iii) Integrated Part Load Value is rated in accordance with ARI Standard 210/240 or 360. Units are rated at 80° F ambient, 80° F entering dry bulb, and 67° F entering wet bulb at ARI rated cfm.
- (iv) YSC072A when used in a horizontal application has an EER of 10.1 and System Power (kW) of 6.83.
- (v) Outdoor Sound Rating shown is tested in accordance with ARI Standard 270. For additional information refer to [Table 127](#).
- (vi) Outdoor motor is 0.40 hp for AK (380V/60 Hz) units.
- (vii) Outdoor motor is 0.75 hp for AK (380V/60 Hz) units.
- (viii) YSC060A3,4,W Oversized Motor and YSC060AK Standard Motor Fan Diameter is 12 x 11.
- (ix) Motor RPM shown is low speed. High speed RPM is 1100/1135. 10. Filter size shown is for low and medium heat models. High heat model filter size recommended is 20 x 30 x 1.
- (x) Standard Motor is 1.00 hp for YSC060AK (380V/60 Hz) units.
- (xi) Standard Motor is 2.00 hp for the YSC072AK (380V/60 Hz) units.
- (xii) Optional 2" pleated filters also available.
- (xiii) Filter size shown for T/YSC060A3,4,W,K is for low and medium heat models. High heat model filter size recommended is 20 x 30 x 1.
- (xiv) Refrigerant charge is an approximate value. For a more precise value, see unit nameplate and service instructions.
- (xv) Heating Performance limit settings and rating data were established and approved under laboratory test conditions using American National Standards Institute standards. Ratings shown are for elevations up to 2000 feet. For elevations above 2000 feet, ratings should be reduced at the rate of 4% for each 1000 feet above sea level. Applicable to Gas/Electric units only.
- (xvi) Second stage/first stage if applicable.
- (xvii) Medium heat is not available for AK (380V/60 Hz) units.
- (xviii) Second stage/first stage if applicable.
- (xix) AFUE is rated in accordance with DOE test procedures.

**General Data**

*(7½-8½ Tons Standard Efficiency)*

**Table 3. General Data —7½-8½ Tons**

	7½ Tons		8½ Tons
	T/YSC090A3,4W,K Single Compressor	T/YSC092A3,4,W <sup>(d)</sup> Dual Compressor	T/YSC102A3,4,W,K <sup>(ii)</sup>
<b>Cooling Performance<sup>(iii)</sup></b>			
Gross Cooling Capacity	95,000	92,000	105,000
EER <sup>(iv)</sup>	10.3/10.1	10.4/10.3	10.3/10.1
Nominal CFM / ARI Rated CFM	3,000/2,625	3,000/2,625	3,400/3,000
ARI Net Cooling Capacity	90,000	87,000	100,000
Integrated Part Load Value <sup>(v)</sup>	—	11.0	11.8
System Power (kW)	8.91	8.37	9.9
<b>Compressor</b>			
Number/Type	1/Scroll	2/Scrolls	2/Scrolls
<b>Sound</b>			
Outdoor Sound Rating (dB) <sup>(vi)</sup>	90	87	86
<b>Outdoor Coil</b>			
Type	Lanced	Lanced	Lanced
Tube Size (in.)	0.3125	0.3125	0.3125
Face Area (sq. ft.)	17.0	17.0	19.83
Rows/FPI	3/17	2/17	2/17
<b>Indoor Coil</b>			
Type	Lanced	Lanced	Lanced
Tube Size (in.)	0.3125	0.3125	0.3125
Face Area (sq. ft.)	9.89	9.89	12.36
Rows/FPI	3/16	3/16	3/16
Refrigerant Control	Short Orifice	Short Orifice	Short Orifice
Drain Connection Number/Size (in.)	1¼ NPT	1¼ NPT	1¼ NPT
<b>Outdoor Fan</b>			
Type	Propeller	Propeller	Propeller
Number Used/Diameter (in.)	1/26	1/26	1/26
Drive Type/No. Speeds	Direct/1	Direct/1	Direct/1
CFM	6,200	6,500	7,100
Number Motors/HP	1/0.70 <sup>(vii)</sup>	1/0.70	1/0.75
Motor RPM	1,075	1,075	1,075
<b>Belt Drive Indoor Fan</b>			
Type	FC Centrifugal	FC Centrifugal	FC Centrifugal
Number Used/Diameter (in.)	1/12x12	1/12x12	1/15x15
Drive Type/Number Speeds	Belt/Variable Sheave	Belt/Variable Sheave	Belt/Variable Sheave
Number Motors	1	1	1
Motor HP (Standard/Oversized)	2.00/3.00	2.00/3.00	2.00/3.00
Motor RPM (Standard/Oversized)	1,750/1,750	1,750/1,750	1,750/1,750
Motor Frame Size (Standard/Oversized)	56/56	56/56	56/56
<b>Filters<sup>(viii)</sup></b>			
Type Furnished	Throwaway	Throwaway	Throwaway
Number Size Recommended	(4) 16x25x2	(4) 16x25x2	(4)20x25x2
<b>Refrigerant Charge (Lbs. of R-22)<sup>(ix)</sup></b>			
Pounds of R-22	11.9	6.2 Circuit 1/3.4 Circuit 2	7.9 Circuit 1/4.0 Circuit 2

## General Data

*(7½-8½ Tons Standard Efficiency)*

**Table 3. (continued) General Data – 7½-8½ Tons**

	7½ Tons		8½ Tons
<b>Heating Performance<sup>(x)</sup></b>			
<b>(Gas/Electric Only)</b>			
<b>Heating Input<sup>(xi)</sup></b>			
Low Heat Input (Btu)	120,000	120,000	120,000
Mid <sup>(xii)</sup> Heat Input (Btu)	150,000/105,000	150,000/105,000	150,000/105,000
High Heat Input (Btu)	200,000/140,000	200,000/140,000	200,000/140,000
<b>Heating Output<sup>(xiii)</sup></b>			
Low Heat Input (Btu)	97,200	97,200	97,200
Mid Heat Input (Btu)	121,500/85,000	121,500/85,000	121,500/85,000
High Heat Input (Btu)	162,000/113,000	162,000/113,000	162,000/113,000
<b>AFUE<sup>(xiv)</sup></b>			
Low Heat Input (Btu)	81	81	81
Mid Heat Input (Btu)	81	81	81
High Heat Input (Btu)	81	81	81
<b>Steady State Efficiency%</b>			
Low Heat Input (Btu)	81	81	81
Mid Heat Input (Btu)	81	81	81
High Heat Input (Btu)	80	80	81
<b>No. Burners</b>			
Low Heat Input (Btu)	3	3	3
Mid Heat Input (Btu)	3	3	3
High Heat Input (Btu)	4	4	4
<b>No. Stages</b>			
Low Heat Input (Btu)	1	1	1
Mid Heat Input (Btu)	2	2	2
High Heat Input (Btu)	2	2	2
<b>Gas Supply Line Pressure</b>			
Natural (minimum/maximum)	4.5/14.0	4.5/14.0	4.5/14.0
LP (minimum/maximum)	10.0/14.0	10.0/14.0	10.0/14.0
<b>Gas Connection Pipe Size (in)</b>			
Low Heat	1/2	1/2	1/2
Mid Heat	3/4	3/4	3/4
High Heat	3/4	3/4	3/4

- (i) YSC092A when applied in a horizontal configuration has a 10.1 EER, 10.7 Integrated Part Load Value, and 8.61 System Power (kW).
- (ii) YSC102A when applied in horizontal configuration has an 11.3 Integrated Part Load Value, 9.8 System Power (kW) and 99,000 ARI Net Cooling Capacity.
- (iii) Cooling Performance is rated at 95 F ambient, 80 F entering dry bulb, 67 F entering wet bulb. Gross capacity does not include the effect of fan motor heat. ARI capacity is net and includes the effect of fan motor heat. Units are suitable for operation to ±20% of nominal cfm. Units are certified in accordance with the Unitary Air-Conditioner Equipment certification program, which is based on ARI Standard 210/240 except AK (380V/60 Hz).
- (iv) EER and/or SEER are rated at ARI conditions and in accordance with DOE test procedures.
- (v) Integrated Part Load Value is rated in accordance with ARI Standard 210/240 or 360. Units are rated at 80° F ambient, 80° F entering dry bulb, and 67° F entering wet bulb at ARI rated cfm.
- (vi) Outdoor Sound Rating shown is tested in accordance with ARI Standard 270. For additional information refer to [Table 127](#).
- (vii) Outdoor motor is 0.75 hp for AK (380V/60 Hz) units.
- (viii) Optional 2" pleated filters also available.
- (ix) Refrigerant charge is an approximate value. For a more precise value, see unit nameplate and service instructions.
- (x) Heating Performance limit settings and rating data were established and approved under laboratory test conditions using American National Standards Institute standards. Ratings shown are for elevations up to 2000 feet. For elevations above 2000 feet, ratings should be reduced at the rate of 4% for each 1000 feet above sea level. Applicable to Gas/Electric units only.
- (xi) Second stage/first stage if applicable.
- (xii) Medium heat is not available for AK (380V/60 Hz) units.
- (xiii) Second stage/first stage if applicable.
- (xiv) AFUE is rated in accordance with DOE test procedures.

## General Data

*(10 Tons Standard Efficiency)*

**Table 4. General Data – 10 Tons**

	<b>10 Tons</b>
	<b>T/YSC120A3,4W,K<sup>(1)</sup></b>
<b>Cooling Performance<sup>(ii)</sup></b>	
Gross Cooling Capacity	118,000
EER <sup>(iii)</sup>	10.4/10.2
Nominal CFM / ARI Rated CFM	4,000/3,200
ARI Net Cooling Capacity	114,000
Integrated Part Load Value <sup>(iv)</sup>	11.3
System Power (kW)	11.18
<b>Compressor</b>	
Number/Type	2/Scrolls
<b>Sound</b>	
Outdoor Sound Rating (dB) <sup>(v)</sup>	86
<b>Outdoor Coil</b>	
Type	Lanced
Tube Size (in.)	0.3125
Face Area (sq. ft.)	19.83
Rows/FPI	2/17
<b>Indoor Coil</b>	
Type	Lanced
Tube Size (in.)	0.3125
Face Area (sq. ft.)	12.36
Rows/FPI	4/16
Refrigerant Control	Short Orifice
Drain Connection Number/Size (in.)	1¾ NPT
<b>Outdoor Fan</b>	
Type	Propeller
Number Used/Diameter (in.)	1/26
Drive Type/No. Speeds	Direct/1
CFM	7,000
Number Motors/HP	1/0.75
Motor RPM	1,075
<b>Belt Drive Indoor Fan</b>	
Type	FC Centrifugal
Number Used/Diameter (in.)	1/15x15
Drive Type/Number Speeds	Belt/Variable Sheave
Number Motors	1
Motor HP (Standard/Oversized)	3.00/5.00
Motor RPM (Standard/Oversized)	1,750/3,450
Motor Frame Size (Standard/Oversized)	56/56
<b>Filters<sup>(vi)</sup></b>	
Type Furnished	Throwaway
Number Size Recommended	(4) 20x25x2
<b>Refrigerant Charge (Lbs. of R-22)<sup>(vii)</sup></b>	
Pounds of R-22	7.2 Circuit 1/5.3 Circuit 2

**Table 4. (continued) General Data – 10 Tons**

	<b>10 Tons</b>
<b>Heating Performance<sup>(viii)</sup></b>	
<b>(Gas/Electric Only)</b>	
<b>Heating Input<sup>(ix)</sup></b>	
Low Heat Input (Btu)	150,000/105,000
Mid <sup>(x)</sup> Heat Input (Btu)	200,000/140,000
High Heat Input (Btu)	250,000/175,000
<b>Heating Output<sup>(xi)</sup></b>	
Low Heat Input (Btu)	121,500/85,000
Mid Heat Input (Btu)	162,000/113,000
High Heat Input (Btu)	202,500/141,800
<b>AFUE%<sup>(xii)</sup></b>	
Low Heat Input (Btu)	81
Mid Heat Input (Btu)	81
High Heat Input (Btu)	81
<b>Steady State Efficiency%</b>	
Low Heat Input (Btu)	81
Mid Heat Input (Btu)	81
High Heat Input (Btu)	81
<b>No. Burners</b>	
Low Heat Input (Btu)	3
Mid Heat Input (Btu)	4
High Heat Input (Btu)	5
<b>No. Stages</b>	
Low Heat Input (Btu)	2
Mid Heat Input (Btu)	2
High Heat Input (Btu)	2
<b>Gas Supply Line Pressure</b>	
Natural (minimum/maximum)	4.5/14.0
LP (minimum/maximum)	10.0/14.0
<b>Gas Connection Pipe Size (in)</b>	
Low Heat	3/4
Mid Heat	3/4
High Heat	3/4

- (i) YSC120A when applied in a horizontal configuration has a 10.1 EER, 112,000 ARI Net Cooling Capacity, 10.7 Integrated Part Load Value and 11.09 System Power (kW).
- (ii) Cooling Performance is rated at 95 F ambient, 80 F entering dry bulb, 67 F entering wet bulb. Gross capacity does not include the effect of fan motor heat. ARI capacity is net and includes the effect of fan motor heat. Units are suitable for operation to ±20% of nominal cfm. Units are certified in accordance with the Unitary Air-Conditioner Equipment certification program, which is based on ARI Standard 210/240 except AK (380V/60 Hz).
- (iii) EER and/or SEER are rated at ARI conditions and in accordance with DOE test procedures.
- (iv) Integrated Part Load Value is rated in accordance with ARI Standard 210/240 or 360. Units are rated at 80° F ambient, 80° F entering dry bulb, and 67° F entering wet bulb at ARI rated cfm.
- (v) Outdoor Sound Rating shown is tested in accordance with ARI Standard 270. For additional information refer to [Table 127](#).
- (vi) Optional 2" pleated filters also available.
- (vii) Refrigerant charge is an approximate value. For a more precise value, see unit nameplate and service instructions.
- (viii) Heating Performance limit settings and rating data were established and approved under laboratory test conditions using American National Standards Institute standards. Ratings shown are for elevations up to 2000 feet. For elevations above 2000 feet, ratings should be reduced at the rate of 4% for each 1000 feet above sea level. Applicable to Gas/Electric units only.
- (ix) Second stage/first stage if applicable.
- (x) Medium heat is not available for AK (380V/60 Hz) units.
- (xi) Second stage/first stage if applicable.
- (xii) AFUE is rated in accordance with DOE test procedures.

## General Data

*(3-5 Tons High Efficiency)*

**Table 5. General Data — 3-5 Tons — 13 SEER Refrigerant**

	3 Tons	4 Tons	5 Tons
	T/YHC033A3,4,W	T/YHC043A3,4,W	T/YHC063A3,4,W
<b>Cooling Performance<sup>(1)</sup></b>			
Gross Cooling Capacity	38,000	49,800	62,400
SEER <sup>(ii)</sup>	13.0	13.0	13.0
Nominal CFM / ARI Rated CFM	1,200/1,200	1,600/1,600	2,000/2,000
ARI Net Cooling Capacity	36,600	47,500	59,500
System Power (kW)	3.33	4.48	5.56
<b>Compressor</b>			
Number/Type	1/Scroll	1/Scroll	1/Scroll
<b>Sound</b>			
Outdoor Sound Rating (dB) <sup>(iii)</sup>	83	85	84
<b>Outdoor Coil</b>			
Type	Lanced	Lanced	Lanced
Tube Size (in.)	0.3125	0.3125	0.3125
Face Area (sq. ft.)	7.19	9.59	10.96
Rows/FPI	2/17	3/17	3/17
<b>Indoor Coil</b>			
Type	Lanced	Lanced	Lanced
Tube Size (in.)	0.3125	0.3125	0.3125
Face Area (sq. ft.)	6.68	6.68	7.71
Rows/FPI	3/16	4/16	4/16
Refrigerant Control	Thermal Expansion Valve	Thermal Expansion Valve	Thermal Expansion Valve
Drain Connection Number/Size (in.)	1¾ NPT	1¾ NPT	1¾ NPT
<b>Outdoor Fan</b>			
Type	Propeller	Propeller	Propeller
Number Used/Diameter (in.)	1/22	1/22	1/22
Drive Type/No. Speeds <sup>(iv)</sup>	Direct/1	Direct/1	Direct/1
CFM	2,550	3,050	3,370
Number Motors/HP	1/0.20	1/0.33	1/0.33
Motor RPM	1,115	1,115	1,115
<b>Belt Drive Indoor Fan</b>			
Type	FC Centrifugal	FC Centrifugal	FC Centrifugal
Number Used/Diameter (in.)	1/11x11	1/11x11	1/11x11
Drive Type/Number Speeds	Belt/Variable Sheave	Belt/Variable Sheave	Belt/Variable Sheave
Number Motors	1	1	1
Motor HP	1.00	1.00	1.00
Standard Motor RPM	1,750	1,750	1,750
Motor Frame Size	56	56	56
<b>Filters<sup>(v), (vi)</sup></b>			
Type Furnished	Throwaway	Throwaway	Throwaway
Number Size Recommended	(2) 20x25x1	(2) 20x25x1	(2) 20x30x1 <sup>(vii)</sup>
<b>Optional Hot Gas Reheat Coil</b>			
Type	Lanced	Lanced	Lanced
Tube Size (in.) OD	0.375	0.375	0.375
Face Area (sq. ft.)	2.22	2.22	2.22
Rows/FPI	1/16	1/16	2/16
<b>Refrigerant Charge (Lbs. of R-22)<sup>(viii)</sup></b>			
Standard	5.3	7.7	8.4
Optional Hot Gas Reheat Coil	5.3	8.5	10.7

**Table 5. (continued) General Data — 3-5 Tons — 13 SEER Refrigerant**

	3 Tons	4 Tons	5 Tons
<b>Heating Performance<sup>(ix)</sup></b>			
<b>(Gas/Electric Only)</b>			
<b>Heating Input</b>			
Low Heat Input (Btu)	60,000	60,000	60,000
Mid Heat Input (Btu)	80,000	80,000	80,000
High Heat Input (Btu)	120,000	120,000	130,000
<b>Heating Output</b>			
Low Heat Input (Btu)	48,000	48,000	48,000
Mid Heat Input (Btu)	64,000	64,000	64,000
High Heat Input (Btu)	96,000	96,000	104,000
<b>AFUE%<sup>(x)</sup></b>			
Low Heat Input (Btu)	81	81	81
Mid Heat Input (Btu)	81	81	81
High Heat Input (Btu)	81	81	80
<b>Steady State Efficiency%</b>			
Low Heat Input (Btu)	81	81	81
Mid Heat Input (Btu)	81	81	81
High Heat Input (Btu)	81	81	80
<b>No. Burners</b>			
Low Heat Input (Btu)	2	2	2
Mid Heat Input (Btu)	2	2	2
High Heat Input (Btu)	3	3	3
<b>No. Stages</b>			
Low Heat Input (Btu)	1	1	1
Mid Heat Input (Btu)	1	1	1
High Heat Input (Btu)	1	1	1
<b>Gas Supply Line Pressure</b>			
Natural (minimum/maximum)	4.5/14.0	4.5/14.0	4.5/14.0
LP (minimum/maximum)	10.0/14.0	10.0/14.0	10.0/14.0
<b>Gas Connection Pipe Size (in.)</b>			
Low Heat	1/2	1/2	1/2
Mid Heat	1/2	1/2	1/2
High Heat	1/2	1/2	1/2

- (i) Cooling performance is rated at 95 F ambient, 80 F entering dry bulb, 67 F entering wet bulb. Gross capacity does not include the effect of fan motor heat. ARI capacity is net and includes the effect of fan motor heat. Units are suitable for operation to ±20% of nominal cfm. Units are certified in accordance with the Unitary Air-Conditioner Equipment certification program, which is based on ARI Standard 210/240 except AK (380V/60 Hz).
- (ii) EER and/or SEER are rated at ARI conditions and in accordance with DOE test procedures.
- (iii) Outdoor Sound Rating shown is tested in accordance with ARI Standard 270. For additional information refer to [Table 127](#).
- (iv) With Dehumidification (Hot Gas Reheat) option: Direct/2 speed.
- (v) Optional 2" pleated filters also available.
- (vi) 20x25x1 filters standard on T/YHC033A & T/YHC043A Low, Medium Heat Models. 20x30x1 filters standard on YHC033 & YHC043A.
- (vii) 2" pleated filters is a factory installed option. 2" pleated filters is standard with the Dehumidification (Hot Gas Reheat) option.
- (viii) Refrigerant charge is an approximate value. For a more precise value, see unit nameplate and service instructions.
- (ix) Heating performance limit settings and rating data were established and approved under laboratory test conditions using American National Standards Institute standards. Ratings shown are for elevations up to 2000 feet. For elevations above 2000 feet, ratings should be reduced at the rate of 4% for each 1000 feet above sea level. Applicable to Gas/Electric units only.
- (x) AFUE and Steady State Efficiency is rated in accordance with DOE test procedures.



**Table 6. General Data — 6 Tons High Efficiency**

	<b>6 Tons</b>
	<b>T/YHC072A3,4,W<sup>(1)</sup></b>
<b>Cooling Performance<sup>(ii)</sup></b>	
Gross Cooling Capacity	73,000
EER <sup>(iii)</sup>	11.5/11.5
Nominal CFM / ARI Rated CFM	2,400/2,100
ARI Net Cooling Capacity	70,000
System Power (kW)	6.09
<b>Compressor</b>	
Number/Type	1/Scroll
<b>Sound</b>	
Outdoor Sound Rating (dB) <sup>(iv)</sup>	89
<b>Outdoor Coil</b>	
Type	Lanced
Tube Size (in.)	0.3125
Face Area (sq. ft.)	17.00
Rows/FPI	3/17
<b>Indoor Coil</b>	
Type	Lanced
Tube Size (in.)	0.3125
Face Area (sq. ft.)	9.89
Rows/FPI	3/16
Refrigerant Control	Short Orifice
Drain Connection Number/Size (in.)	1¾ NPT
<b>Outdoor Fan</b>	
Type	Propeller
Number Used/Diameter (in.)	1/26
Drive Type/No. Speeds	Direct/1
CFM	6,100
Number Motors/HP	1/0.70
Motor RPM	1,075
<b>Direct Drive Indoor Fan</b>	
Type	—
Number Used/Diameter (in.) <sup>(v)</sup>	—
Drive Type/Number Speeds	—
Number Motors	—
Motor HP (Standard/Oversized)	—
Motor RPM (Standard/Oversized) <sup>(vi)</sup>	—
Motor Frame Size (Standard/Oversized)	—
<b>Belt Drive Indoor Fan</b>	
Type	FC Centrifugal
Number Used/Diameter (in.)	1/12x12
Drive Type/Number Speeds <sup>(vii)</sup>	Belt/Variable Sheave
Number Motors	1
Motor HP (Standard/Oversized)	1.00/2.00
Motor RPM (Standard/Oversized)	1,750/1,750
Motor Frame Size (Standard/Oversized)	56/56
<b>Filters<sup>(viii)</sup></b>	
Type Furnished	Throwaway
Number Size Recommended <sup>(ix)</sup>	(4)16x25x2
<b>Optional Hot Gas Reheat Coil<sup>(x)</sup></b>	
Type	—
Tube Size (in.) OD	—
Face Area (sq. ft.)	—
Rows/FPI	—
<b>Refrigerant Charge (Lbs. of R-22)<sup>(xi)</sup></b>	
Standard	10.7
Optional Hot Gas Reheat Coil	—

**Table 6. (continued) General Data — 6 Tons High Efficiency**

	<b>6 Tons</b>
<b>Heating Performance<sup>(xii)</sup></b>	
<b>(Gas/Electric Only)</b>	
<b>Heating Input<sup>(xiii)</sup></b>	
Low Heat Input (Btu)	80,000
Mid Heat Input (Btu)	120,000/84,000
High Heat Input (Btu)	150,000/105,000
<b>Heating Output<sup>(xiv)</sup></b>	
Low Heat Input (Btu)	64,800
Mid Heat Input (Btu)	97,200/68,000
High Heat Input (Btu)	121,500/85,000
<b>AFUE%<sup>(xv)</sup></b>	
Low Heat Input (Btu)	81
Mid Heat Input (Btu)	81
High Heat Input (Btu)	81
<b>Steady State Efficiency%</b>	
Low Heat Input (Btu)	81
Mid Heat Input (Btu)	81
High Heat Input (Btu)	81
<b>No. Burners</b>	
Low Heat Input (Btu)	2
Mid Heat Input (Btu)	3
High Heat Input (Btu)	3
<b>No. Stages</b>	
Low Heat Input (Btu)	1
Mid Heat Input (Btu)	1
High Heat Input (Btu)	2
<b>Gas Supply Line Pressure</b>	
Natural (minimum/maximum)	4.5/14.0
LP (minimum/maximum)	10.0/14.0
<b>Gas Connection Pipe Size (in)</b>	
Low Heat	1/2
Mid Heat	1/2
High Heat	3/4

- (i) YHC072A when applied in a horizontal configuration has an 11.3 EER and 6.2 System Power (kW).
- (ii) Cooling Performance is rated at 95 F ambient, 80 F entering dry bulb, 67 F entering wet bulb. Gross capacity does not include the effect of fan motor heat. ARI capacity is net and includes the effect of fan motor heat. Units are suitable for operation to ±20% of nominal cfm. Units are certified in accordance with the Unitary Air-Conditioner Equipment certification program, which is based on ARI Standard 210/240 except AK (380V/60 Hz).
- (iii) EER and/or SEER are rated at ARI conditions and in accordance with DOE test procedures.
- (iv) Outdoor Sound Rating shown is tested in accordance with ARI Standard 270. For additional information refer to [Table 127](#).
- (v) YHC060A Oversized Motor Fan Diameter is 12 x 11.
- (vi) Motor RPM shown is low speed. High speed Motor RPM is 1,100/1,135.
- (vii) Belt Drive Motor is not available for YHC060A1.
- (viii) Optional 2" pleated filters also available.
- (ix) 2" pleated filters is a factory installed option. 2" pleated filters is standard with the Dehumidification (Hot Gas Reheat) option.
- (x) Available on three-phase only.
- (xi) Refrigerant charge is an approximate value. For a more precise value, see unit nameplate and service instructions.
- (xii) Heating Performance limit settings and rating data were established and approved under laboratory test conditions using American National Standards Institute standards. Ratings shown are for elevations up to 2000 feet. For elevations above 2000 feet, ratings should be reduced at the rate of 4% for each 1000 feet above sea level. Applicable to Gas/Electric units only.
- (xiii) Second stage/first stage if applicable.
- (xiv) Second stage/first stage if applicable.
- (xv) AFUE is rated in accordance with DOE test procedures.

## General Data

*(7½-10 Tons High Efficiency)*

**Table 7. General Data — 7½-10 Tons High Efficiency**

	7½ Tons	8½ Tons	10 Tons
	T/YHC092A3,4,W <sup>(i)</sup>	T/YHC102A3,4,W <sup>(ii)</sup>	T/YHC120A3,4,W <sup>(iii)</sup>
<b>Cooling Performance<sup>(iv)</sup></b>			
Gross Cooling Capacity	94,000	103,000	117,000
EER <sup>(v)</sup>	11.5/11.5	11.5/11.5	11.2/11.2
Nominal CFM / ARI Rated CFM	3,000/2,625	3,400/3,000	4,000/3,200
ARI Net Cooling Capacity	90,000	98,000	109,000
Integrated Part Load Value <sup>(vi)</sup>	11.8	11.8	11.7
System Power (kW)	7.83	8.52	9.73
<b>Compressor</b>			
Number/Type	2/Scrolls	2/Scrolls	2/Scrolls
<b>Sound</b>			
Outdoor Sound Rating (dB) <sup>(vii)</sup>	91	89	88
<b>Outdoor Coil</b>			
Type	Lanced	Lanced	Lanced
Tube Size (in.)	0.3125	0.3125	0.3125
Face Area (sq. ft.)	17.5	19.83	27.21
Rows/FPI	3/17	3/17	3/17
<b>Indoor Coil</b>			
Type	Lanced	Lanced	Lanced
Tube Size (in.)	0.3125	0.3125	0.3125
Face Area (sq. ft.)	12.36	12.36	12.36
Rows/FPI	3/16	4/16	5/16
Refrigerant Control	Short Orifice	Short Orifice	Short Orifice
Drain Connection Number/Size (in.)	1¾ NPT	1¾ NPT	1¾ NPT
<b>Outdoor Fan</b>			
Type	Propeller	Propeller	Propeller
Number Used/Diameter (in.)	1/26	1/26	1/26
Drive Type/No. Speeds	Direct/1	Direct/1	Direct/1
CFM	6,200	6,600	7,000
Number Motors/HP	1/0.70	1/0.75	1/0.75
Motor RPM	1,075	1,075	1,075
<b>Belt Drive Indoor Fan</b>			
Type	FC Centrifugal	FC Centrifugal	FC Centrifugal
Number Used/Diameter (in.)	1/15x15	1/15x15	1/15x15
Drive Type/Number Speeds	Belt/Variable Sheave	Belt/Variable Sheave	Belt/Variable Sheave
Number Motors	1	1	1
Motor HP (Standard/Oversized)	2.00/3.00	2.00/3.00	3.00/5.00
Motor RPM (Standard/Oversized)	1,750/1,750	1,750/1,750	1,750/3,450
Motor Frame Size (Standard/Oversized)	56/56	56/56	56/56
<b>Filters<sup>(viii)</sup></b>			
Type Furnished	Throwaway	Throwaway	Throwaway
Number Size Recommended	(4) 20x25x2	(4) 20x25x2	(4) 20x25x2
<b>Optional Hot Gas Reheat Coil</b>			
Type	Lanced	Lanced	Lanced
Tube Size (in.) OD	0.375	0.375	0.375
Face Area (sq. ft.)	5.19	5.19	5.19
Rows/FPI	2/16	2/16	2/16
<b>Refrigerant Charge (Lbs. of R-22)<sup>(ix),(x)</sup></b>			
Pounds of R-22	6.4 Circuit 1/6.2 Circuit 2	7.4 Circuit 1/7.1 Circuit 2	11.0 Circuit 1/7.3 Circuit 2

**General Data**

*(7½-10 Tons High Efficiency)*

**Table 7. (continued) General Data – 7½-10 Tons High Efficiency**

	<b>7½ Tons</b>	<b>8½ Tons</b>	<b>10 Tons</b>
<b>Heating Performance<sup>(xi)</sup></b>			
<b>(Gas/Electric Only)</b>			
<b>Heating Input<sup>(xii)</sup></b>			
Low Heat Input (Btu)	120,000/84,000	120,000/84,000	150,000/105,000
Mid Heat Input (Btu)	150,000/105,000	150,000/105,000	200,000/140,000
High Heat Input (Btu)	200,000/140,000	200,000/140,000	250,000/175,000
<b>Heating Output<sup>(xiii)</sup></b>			
Low Heat Input (Btu)	97,200/68,000	97,200/68,000	121,500/85,000
Mid Heat Input (Btu)	121,500/85,000	121,500/85,000	162,000/113,000
High Heat Input (Btu)	162,000/113,000	162,000/113,000	202,500/141,800
<b>AFUE%<sup>(xiv)</sup></b>			
Low Heat Input (Btu)	81	81	81
Mid Heat Input (Btu)	81	81	81
High Heat Input (Btu)	81	81	81
<b>Steady State Efficiency%</b>			
Low Heat Input (Btu)	81	81	81
Mid Heat Input (Btu)	81	81	81
High Heat Input (Btu)	80	80	81
<b>No. Burners</b>			
Low Heat Input (Btu)	3	3	3
Mid Heat Input (Btu)	3	3	4
High Heat Input (Btu)	4	4	5
<b>No. Stages</b>			
Low Heat Input (Btu)	1	1	2
Mid Heat Input (Btu)	2	2	2
High Heat Input (Btu)	2	2	2
<b>Gas Supply Line Pressure</b>			
Natural (minimum/maximum)	4.5/14.0	4.5/14.0	4.5/14.0
LP (minimum/maximum)	10.0/14.0	10.0/14.0	10.0/14.0
<b>Gas Connection Pipe Size (in)</b>			
Low Heat	1/2	1/2	3/4
Mid Heat	3/4	3/4	3/4
High Heat	3/4	3/4	3/4

- (i) YHC092A when applied in a horizontal configuration has an 11.3 EER, 89,000 ARI Net Cooling Capacity, 11.4 Integrated Part Load Value, and 7.88 System Power (kW).
- (ii) YHC102A when applied in a horizontal configuration has an 11.3 EER, 89,000 ARI Net Cooling Capacity, 11.4 Integrated Part Load Value, and 7.88 System Power (kW).
- (iii) YHC120A when applied in a horizontal configuration has an 10.7 EER, 11.2 IPL, 108,000 ARI Net Cooling and 10.09 System Power (kW).
- (iv) Cooling Performance is rated at 95 F ambient, 80 F entering dry bulb, 67 F entering wet bulb. Gross capacity does not include the effect of fan motor heat. ARI capacity is net and includes the effect of fan motor heat. Units are suitable for operation to ±20% of nominal cfm. Units are certified in accordance with the Unitary Air-Conditioner Equipment certification program, which is based on ARI Standard 210/240 except AK (380V/60 Hz).
- (v) EER and/or SEER are rated at ARI conditions and in accordance with DOE test procedures.
- (vi) Integrated Part Load Value is rated in accordance with ARI Standard 210/240 or 360. Units are rated at 80° F ambient, 80° F entering dry bulb, and 67° F entering wet bulb at ARI rated cfm.
- (vii) Outdoor Sound Rating shown is tested in accordance with ARI Standard 270. For additional information refer to [Table 127](#).
- (viii) Optional 2" pleated filters also available.
- (ix) Refrigerant charge is an approximate value. For a more precise value, see unit nameplate and service instructions.
- (x) Refrigerant charge for optional hot gas reheat same as for high efficiency units.
- (xi) Heating Performance limit settings and rating data were established and approved under laboratory test conditions using American National Standards Institute standards. Ratings shown are for elevations up to 2000 feet. For elevations above 2000 feet, ratings should be reduced at the rate of 4% for each 1000 feet above sea level. Applicable to Gas/Electric units only.
- (xii) Second stage/first stage if applicable.
- (xiii) Second stage/first stage if applicable.
- (xiv) AFUE is rated in accordance with DOE test procedures.

# Performance Data

**Table 8. Gross Cooling Capacities 3 Tons Three Phase Standard Efficiency T/YSC036A3,4,W**

		Ambient Temperature																							
		85			95			105			115														
Air Flow CFM	Ent DB (F)	Entering Wet Bulb																							
		61	67	73	61	67	73	61	67	73	61	67	73												
		MBH	SHC	MBH	SHC	MBH	SHC	MBH	SHC	MBH	SHC	MBH	SHC	MBH	SHC										
1080	75	34.6	29.0	38.6	22.3	40.6	14.7	31.2	27.3	36.6	21.1	39.5	13.8	28.2	25.6	33.4	19.6	37.8	12.9	25.1	24.1	29.6	18.2	35.5	11.9
	80	35.6	35.0	38.8	27.3	41.0	20.2	32.6	32.6	36.8	26.6	39.8	19.5	30.0	30.0	33.5	25.2	38.0	18.5	27.3	27.3	29.9	23.5	35.6	17.5
	85	37.6	37.6	39.2	32.5	41.5	24.7	35.6	35.6	37.2	32.2	40.1	24.2	32.8	32.8	34.2	31.0	38.2	23.8	30.1	30.1	30.7	29.3	35.8	23.0
	90	39.3	39.3	39.7	37.6	42.0	29.2	37.8	37.8	37.9	37.6	40.4	29.1	35.7	35.7	35.7	35.7	38.5	28.9	33.0	33.0	32.9	32.9	36.0	28.4
1200	75	35.6	30.9	39.0	22.8	40.9	14.9	32.2	29.2	37.3	22.1	39.8	14.1	29.0	27.5	34.3	20.7	38.2	13.1	25.9	25.9	30.4	19.0	36.0	12.1
	80	36.7	36.7	39.3	28.4	41.4	20.6	34.3	34.3	37.4	28.1	40.2	20.3	31.4	31.4	34.5	26.9	38.4	19.3	28.6	28.6	30.7	25.2	36.1	18.3
	85	38.7	38.7	39.7	33.9	41.9	25.3	37.0	37.0	37.9	34.0	40.5	25.0	34.5	34.5	35.3	33.2	38.7	24.8	31.5	31.5	31.7	31.6	36.3	24.2
	90	40.2	40.2	40.4	39.2	42.3	30.1	38.8	38.8	38.8	38.8	40.9	30.2	37.1	37.1	37.0	37.0	39.1	30.3	34.6	34.6	34.6	34.6	36.6	30.0
1320	75	36.4	32.6	39.4	23.5	41.1	15.1	33.2	31.0	37.7	23.0	40.1	14.3	29.8	29.3	34.9	21.8	38.5	13.4	26.8	26.8	30.9	20.0	36.3	12.4
	80	37.7	37.7	39.7	29.4	41.6	20.9	35.7	35.7	37.9	29.3	40.4	21.2	32.7	32.7	35.2	28.5	38.7	19.9	29.8	29.8	31.4	26.8	36.5	19.0
	85	39.4	39.4	40.2	35.2	42.1	25.9	37.9	37.9	38.5	35.6	40.8	25.7	35.9	35.9	36.2	35.3	39.1	25.7	32.9	32.9	32.9	32.9	36.7	25.3
	90	40.8	40.8	40.9	40.5	42.6	30.8	39.7	39.7	39.6	39.6	41.2	31.2	38.0	38.0	38.0	38.0	39.5	31.6	35.9	35.9	35.9	35.9	37.1	31.5
1440	75	37.0	34.1	39.7	24.0	41.3	15.3	34.1	32.8	38.0	23.7	40.3	14.5	30.6	30.6	35.5	22.7	38.7	13.6	27.7	27.7	31.4	21.0	36.6	12.6
	80	38.4	38.4	40.0	30.3	41.8	21.2	36.7	36.7	38.3	30.5	40.8	21.0	33.9	33.9	35.8	30.0	39.0	20.4	30.8	30.8	32.0	28.4	36.8	19.7
	85	40.0	40.0	40.6	36.3	42.4	26.4	38.7	38.7	39.0	37.0	41.2	26.7	36.8	36.8	36.8	36.8	39.4	26.6	34.2	34.2	34.2	34.2	37.0	26.4
	90	41.4	41.4	41.4	41.4	42.9	31.6	40.3	40.3	40.3	40.3	41.5	32.1	38.7	38.7	38.7	38.7	39.9	32.7	36.7	36.7	36.7	36.7	37.6	33.0

**Notes:**

1. All capacities shown are gross and have not considered indoor fan heat. To obtain **NET** cooling capacity subtract indoor fan heat. For indoor fan heat formula, refer to appropriate airflow table notes.
2. MBH = Total Gross Capacity
3. SHC = Sensible Heat Capacity

**Table 9. Gross Cooling Capacities 4 Tons Three Phase Standard Efficiency T/YSC048A3,4,W**

		Ambient Temperature																							
		85			95			105			115														
Air Flow CFM	Ent DB (F)	Entering Wet Bulb																							
		61	67	73	61	67	73	61	67	73	61	67	73												
		MBH	SHC	MBH	SHC	MBH	SHC	MBH	SHC	MBH	SHC	MBH	SHC	MBH	SHC										
1440	75	44.8	38.6	51.4	29.8	56.1	20.1	41.0	36.6	48.2	28.2	53.7	18.9	37.3	34.7	44.2	26.4	50.8	17.6	33.4	32.7	39.6	25.2	47.1	16.0
	80	46.0	46.0	51.6	37.4	56.5	27.9	42.9	42.9	48.3	35.8	54.0	26.6	39.7	39.7	44.4	34.0	51.0	25.2	36.4	36.4	40.0	32.0	47.2	23.6
	85	49.6	49.6	52.0	44.8	56.7	34.8	46.8	46.8	48.9	43.6	54.2	34.0	43.6	43.6	45.1	41.8	51.2	32.7	40.3	40.3	41.0	39.8	47.4	31.1
	90	52.5	52.5	52.9	52.2	57.2	41.6	50.2	50.2	50.1	50.1	54.6	41.1	47.2	47.2	47.2	47.2	51.5	40.1	43.9	43.9	43.9	43.9	47.7	38.6
1600	75	46.1	41.1	52.1	31.1	56.7	20.5	42.1	39.0	49.1	29.6	54.4	19.3	38.3	37.1	45.1	27.8	51.5	18.0	34.3	34.3	40.6	25.7	47.9	16.5
	80	48.1	48.1	52.4	39.3	57.2	29.0	44.9	44.9	49.2	37.9	54.7	27.7	41.5	41.5	45.4	36.2	51.7	26.3	38.1	38.1	41.0	34.2	48.0	24.8
	85	51.4	51.4	53.0	47.3	57.7	36.7	48.7	48.7	50.0	46.4	55.0	35.5	45.6	45.6	46.3	44.8	51.9	34.6	42.1	42.1	42.1	42.1	48.2	33.0
	90	54.2	54.2	54.2	54.2	58.0	43.5	51.9	51.9	51.9	51.9	55.4	43.2	49.1	49.1	49.1	49.1	52.3	42.5	45.9	45.9	45.9	45.9	48.7	41.3
1760	75	47.2	43.5	52.8	32.3	57.3	20.9	43.3	41.5	49.8	30.9	54.9	19.7	39.1	39.1	45.8	29.1	52.0	18.3	35.6	35.6	41.3	27.1	48.5	16.8
	80	49.7	49.7	53.1	41.0	57.8	30.1	46.7	46.7	50.1	40.0	55.3	28.8	43.3	43.3	46.2	38.3	52.3	27.4	39.7	39.7	41.8	36.3	48.7	25.9
	85	52.8	52.8	53.8	49.7	58.1	37.7	50.3	50.3	51.0	49.1	55.6	37.0	47.2	47.2	47.2	47.2	52.5	36.1	43.7	43.7	43.7	43.7	48.9	34.9
	90	55.5	55.5	55.5	55.5	58.7	45.3	53.4	53.4	53.4	53.4	56.1	45.2	50.7	50.7	50.7	50.7	53.1	44.7	47.6	47.6	47.6	47.6	49.5	43.8
1920	75	48.2	45.8	53.3	33.4	57.8	21.3	44.4	43.8	50.4	32.1	55.4	20.0	40.3	40.3	46.5	30.4	52.5	18.6	36.6	36.6	41.9	28.3	49.0	17.2
	80	51.0	51.0	53.7	42.7	58.3	31.1	48.1	48.1	50.7	41.9	55.7	29.6	44.7	44.7	47.0	40.3	52.8	28.4	41.1	41.1	42.6	38.3	49.2	26.9
	85	53.9	53.9	54.6	51.8	58.6	38.7	51.6	51.6	51.9	51.5	56.2	38.4	48.6	48.6	48.6	48.6	53.1	37.7	45.2	45.2	45.2	45.2	49.4	36.6
	90	56.6	56.6	56.6	56.6	59.3	47.0	54.6	54.6	54.5	54.5	56.8	47.1	52.0	52.0	52.0	52.0	53.8	46.9	49.0	49.0	49.0	49.0	50.3	46.1

**Notes:**

1. All capacities shown are gross and have not considered indoor fan heat. To obtain **NET** cooling capacity subtract indoor fan heat. For indoor fan heat formula, refer to appropriate airflow table notes.
2. MBH = Total Gross Capacity
3. SHC = Sensible Heat Capacity

## Performance Data

*(5-6 Tons Standard Efficiency)*

**Table 10. Gross Cooling Capacities 5 Tons Three Phase Standard Efficiency T/YSC060A3,4,W,K**

		Ambient Temperature																							
		85			95			105			115														
Air Flow CFM	Ent DB (F)	Entering						Wet Bulb																	
		61	67	73	61	67	73	61	67	73	61	67	73												
		MBH	SHC	MBH	SHC	MBH	SHC	MBH	SHC	MBH	SHC	MBH	SHC	MBH	SHC	MBH	SHC	MBH	SHC						
1800	75	57.4	49.1	64.8	37.9	69.2	25.3	53.3	47.0	61.8	36.3	67.2	24.1	49.4	45.0	57.6	34.3	64.3	22.8	45.2	42.9	52.4	32.7	60.6	21.2
	80	59.0	59.0	65.1	47.1	69.8	35.0	55.6	55.6	62.0	45.7	67.6	33.8	52.2	52.2	57.8	43.9	64.6	32.3	48.6	48.6	52.8	41.6	60.8	30.6
	85	63.1	63.1	65.7	56.2	70.2	42.9	60.3	60.3	62.7	55.3	68.0	42.3	56.8	56.8	58.9	53.6	64.9	41.3	52.9	52.9	54.0	51.4	61.0	39.9
	90	66.4	66.4	66.9	65.2	70.8	51.0	64.1	64.1	64.1	64.1	68.5	50.8	61.1	61.1	61.1	61.1	65.4	50.1	57.5	57.5	57.5	57.5	61.5	49.0
2000	75	59.0	52.2	65.7	39.4	69.8	25.7	54.9	50.1	62.8	37.9	67.8	24.6	50.7	48.0	58.9	36.1	64.9	23.2	46.5	45.9	53.5	33.8	61.3	21.6
	80	61.3	61.3	66.0	49.2	70.2	35.6	58.1	58.1	63.1	48.2	68.1	34.8	54.4	54.4	59.2	46.6	65.3	33.7	50.6	50.6	54.0	44.3	61.5	32.0
	85	65.1	65.1	66.8	59.1	70.9	44.2	62.5	62.5	64.0	58.5	68.7	43.8	59.3	59.3	60.4	57.3	65.7	43.1	55.2	55.2	55.8	55.2	61.8	41.9
	90	68.1	68.1	68.0	68.0	71.6	52.9	65.9	65.9	65.9	65.9	69.4	52.9	63.1	63.1	63.1	63.1	66.3	52.5	59.7	59.7	59.7	59.7	62.4	51.7
2200	75	60.3	55.2	66.3	40.6	70.2	26.1	56.3	53.1	63.6	39.5	68.2	25.0	52.0	51.0	59.9	37.8	65.4	23.6	47.7	47.7	54.5	35.4	61.8	22.0
	80	63.1	63.1	66.8	51.2	70.8	37.9	60.2	60.2	64.0	50.5	68.7	35.6	56.5	56.5	60.3	49.1	65.8	34.6	52.4	52.4	55.2	46.9	62.1	33.3
	85	66.5	66.5	67.7	61.6	71.5	45.4	64.2	64.2	65.0	61.3	69.4	45.2	61.2	61.2	61.7	60.5	66.4	44.7	57.3	57.3	57.3	57.3	62.5	43.8
	90	69.4	69.4	69.3	69.3	72.2	54.6	67.3	67.3	67.3	67.3	70.1	54.9	64.6	64.6	64.6	64.6	67.1	54.8	61.2	61.2	61.2	61.2	63.2	54.2
2400	75	61.5	58.0	66.9	41.8	70.6	26.5	57.6	56.0	64.2	40.8	68.6	25.4	53.0	53.0	60.6	39.3	65.9	24.0	49.1	49.1	55.4	37.1	62.2	22.4
	80	64.5	64.5	67.5	53.0	71.2	38.8	61.8	61.8	64.7	52.5	69.1	36.4	58.3	58.3	61.1	51.4	66.3	35.5	53.9	53.9	56.3	49.5	62.5	34.3
	85	67.7	67.7	68.5	63.9	72.0	46.5	65.4	65.4	65.9	63.9	69.9	46.5	62.5	62.5	62.5	62.5	66.9	46.2	58.9	58.9	58.9	58.9	63.0	45.5
	90	70.4	70.4	70.4	70.4	72.8	56.1	68.4	68.4	68.4	68.4	70.6	56.6	65.8	65.8	65.8	65.8	67.7	56.8	62.4	62.4	62.4	62.4	63.9	56.5

**Notes:**

1. All capacities shown are gross and have not considered indoor fan heat. To obtain **NET** cooling capacity subtract indoor fan heat. For indoor fan heat formula, refer to appropriate airflow table notes.
2. MBH = Total Gross Capacity
3. SHC = Sensible Heat Capacity

**Table 11. Gross Cooling Capacities 6 Tons Three Phase Standard Efficiency T/YSC072A,3,4,W,K**

		Ambient Temperature																							
		85			95			105			115														
Air Flow CFM	Ent DB (F)	Entering						Wet Bulb																	
		61	67	73	61	67	73	61	67	73	61	67	73												
		MBH	SHC	MBH	SHC	MBH	SHC	MBH	SHC	MBH	SHC	MBH	SHC	MBH	SHC	MBH	SHC	MBH	SHC						
2160	75	65.9	55.0	73.4	43.5	76.7	28.3	61.0	52.5	70.7	40.9	75.4	27.3	56.3	50.1	66.3	38.8	73.2	26.0	51.7	47.7	60.9	36.4	70.3	24.6
	80	67.6	66.2	73.7	52.2	77.5	38.9	63.2	63.2	70.9	51.1	76.0	37.8	59.2	59.2	66.4	49.1	73.7	36.4	55.3	55.3	61.0	46.6	70.6	34.9
	85	71.4	71.4	74.2	61.9	78.6	47.4	68.5	68.5	71.4	61.3	76.5	46.6	64.4	64.4	67.3	59.7	74.0	46.0	60.4	60.4	62.2	57.3	70.8	45.0
	90	74.6	74.6	75.3	71.3	79.3	55.7	72.4	72.4	72.8	71.3	77.2	55.5	69.5	69.5	69.5	69.5	74.6	55.4	65.7	65.7	65.6	65.6	71.2	54.8
2400	75	67.7	58.3	74.0	43.8	77.1	28.7	62.9	55.9	71.7	42.6	75.9	27.7	57.9	53.4	67.9	40.8	73.7	26.4	53.2	51.0	62.4	38.3	70.9	25.0
	80	69.7	69.7	74.6	54.1	78.0	39.5	66.2	66.2	72.0	53.6	76.6	39.2	61.8	61.8	68.0	52.0	74.3	37.9	57.8	57.8	62.6	49.6	71.3	36.3
	85	73.4	73.4	75.3	64.5	79.0	48.2	70.9	70.9	72.7	64.5	77.2	47.9	67.4	67.4	69.1	63.6	74.8	47.6	63.2	63.2	64.2	61.4	71.7	47.0
	90	76.2	76.2	76.5	74.3	79.9	57.1	74.3	74.3	74.3	74.3	77.9	57.4	71.7	71.7	71.7	71.7	75.5	57.7	68.5	68.5	68.4	68.4	72.2	57.5
2640	75	69.1	61.4	74.7	44.9	77.4	29.0	64.5	59.1	72.5	44.3	76.2	28.1	59.4	56.6	69.0	42.5	74.2	26.9	54.7	54.2	63.6	40.1	71.3	25.4
	80	71.6	71.6	75.3	55.8	78.4	40.0	68.6	68.6	72.8	55.8	77.0	41.1	64.2	64.2	69.1	54.7	74.6	38.6	60.0	60.0	63.9	52.4	71.9	37.7
	85	74.8	74.8	76.1	66.8	79.4	49.1	72.7	72.7	73.8	67.3	77.8	49.3	69.7	69.7	70.5	66.9	75.4	49.1	65.7	65.7	66.1	65.4	72.3	48.7
	90	77.4	77.4	77.5	76.8	80.3	58.4	75.8	75.8	75.8	75.8	78.5	59.0	73.4	73.4	73.3	73.3	76.2	59.7	70.5	70.5	70.5	70.5	73.0	59.8
2880	75	70.2	64.1	75.2	45.8	77.6	29.4	66.1	62.3	73.1	45.4	76.5	28.5	60.9	59.7	69.8	44.2	74.5	27.3	56.2	56.2	64.7	41.9	71.7	25.8
	80	72.9	72.9	75.9	57.4	78.7	40.4	70.3	70.3	73.6	57.8	77.3	41.8	66.5	66.5	70.1	57.1	75.2	41.1	62.0	62.0	65.2	55.2	72.1	38.5
	85	75.9	75.9	76.8	68.8	79.7	49.9	74.0	74.0	74.7	69.8	78.5	50.6	71.3	71.3	71.6	69.8	75.9	50.4	67.8	67.8	67.7	67.7	72.9	50.1
	90	78.3	78.3	78.3	78.3	80.7	59.6	76.8	76.8	76.8	76.8	79.0	60.5	74.6	74.6	74.6	74.6	76.7	61.6	71.9	71.9	71.9	71.9	73.7	61.9

**Notes:**

1. All capacities shown are gross and have not considered indoor fan heat. To obtain **NET** cooling capacity subtract indoor fan heat. For indoor fan heat formula, refer to appropriate airflow table notes.
2. MBH = Total Gross Capacity
3. SHC = Sensible Heat Capacity

## Performance Data

*(7½ Tons Standard Efficiency)*

**Table 12. Gross Cooling Capacities 7½ Tons Three Phase Single Compressor Standard Efficiency T/YSC090A,3,4,W,K**

		Ambient Temperature																							
		85			95			105			115														
Air Ent Flow DB	CFM (F)	Entering Wet Bulb																							
		61		67		73		61		67		73		61		67		73							
		MBH	SHC	MBH	SHC	MBH	SHC	MBH	SHC	MBH	SHC	MBH	SHC	MBH	SHC	MBH	SHC	MBH	SHC	MBH	SHC				
2700	75	87.4	73.8	96.2	56.7	98.8	36.7	80.6	70.3	93.3	54.3	98.8	35.6	73.5	66.6	86.9	51.2	96.8	33.9	66.6	63.1	78.4	48.2	92.8	31.8
	80	89.6	88.9	96.6	68.7	100.0	49.9	83.4	83.4	93.5	68.3	99.9	50.2	77.6	77.6	87.2	65.3	97.4	48.2	71.6	71.6	78.9	61.5	92.9	46.0
	85	94.2	94.2	97.5	81.6	101.2	60.4	90.4	90.4	94.4	82.2	100.9	61.9	84.8	84.8	88.5	79.8	97.8	61.4	78.5	78.5	80.7	76.2	93.2	59.9
	90	98.0	98.0	98.7	93.9	102.3	71.0	95.8	95.8	96.2	95.8	101.2	72.9	91.6	91.6	91.6	91.6	98.5	74.3	86.0	86.0	86.0	86.0	93.7	73.5
3000	75	89.7	78.4	96.7	57.3	99.1	37.2	83.0	75.0	94.6	56.7	99.2	36.1	75.8	71.3	88.9	53.9	97.5	34.5	68.7	67.7	80.3	50.1	93.8	32.5
	80	92.2	92.2	97.5	70.9	100.3	50.4	87.4	87.4	95.0	71.8	100.4	50.9	81.4	81.4	89.3	69.5	98.3	50.3	75.0	75.0	81.1	65.8	94.1	48.1
	85	96.5	96.5	98.5	84.4	101.5	61.2	93.8	93.8	96.1	86.6	101.6	63.4	88.9	88.9	91.0	85.5	98.8	63.7	82.5	82.5	83.7	82.1	94.4	63.1
	90	99.5	99.5	99.9	97.0	102.6	72.3	98.2	98.2	98.2	98.2	101.9	75.0	94.9	94.9	94.9	94.9	99.7	77.4	90.1	90.1	90.0	90.0	95.3	77.7
3300	75	91.5	82.5	97.7	59.0	99.3	37.7	85.2	79.6	95.5	58.8	99.5	36.6	78.0	76.0	90.5	56.5	98.0	35.1	70.5	70.5	82.1	52.8	94.5	33.2
	80	94.4	94.4	98.1	72.8	100.5	55.0	90.7	90.7	96.2	74.8	100.8	51.6	84.7	84.7	91.1	73.5	98.9	51.5	78.0	78.0	83.2	70.0	95.0	50.1
	85	98.0	98.0	99.2	86.8	101.7	62.0	96.1	96.1	97.5	90.5	102.0	64.7	92.0	92.0	93.1	90.6	99.5	65.6	86.2	86.2	86.2	86.2	95.4	65.8
	90	100.5	100.5	100.7	99.4	102.8	73.4	99.9	99.9	99.9	99.9	102.4	76.8	97.2	97.2	97.2	97.2	100.5	80.1	93.0	93.0	93.0	93.0	96.5	81.4
3600	75	92.9	86.2	98.1	59.9	99.4	38.2	87.3	84.1	96.3	60.6	99.8	37.2	79.6	79.6	91.7	58.9	98.3	35.7	72.9	72.9	83.7	55.4	95.1	33.8
	80	96.0	96.0	98.6	74.3	100.7	56.8	93.1	93.1	97.1	77.5	101.0	55.7	87.6	87.6	92.5	77.2	99.5	52.7	80.7	80.7	85.1	74.1	95.5	51.6
	85	99.0	99.0	99.7	88.7	101.8	62.7	97.8	97.8	98.6	93.7	102.3	65.8	94.4	94.4	94.4	94.4	100.0	67.3	89.1	89.1	89.1	89.1	96.3	68.3
	90	101.1	101.1	101.1	101.1	103.0	74.4	101.0	101.0	101.0	101.0	102.8	78.4	98.9	98.9	98.9	98.9	101.2	82.4	95.1	95.1	95.1	95.1	97.5	84.6

**Notes:**

1. All capacities shown are gross and have not considered indoor fan heat. To obtain **NET** cooling capacity subtract indoor fan heat. For indoor fan heat formula, refer to appropriate airflow table notes.
2. MBH = Total Gross Capacity
3. SHC = Sensible Heat Capacity

**Table 13. Gross Cooling Capacities 7½ Tons Three Phase Dual Compressors Standard Efficiency T/YSC092A,3,4,W**

		Ambient Temperature																							
		85			95			105			115														
Air Ent Flow DB	CFM (F)	Entering Wet Bulb																							
		61		67		73		61		67		73		61		67		73							
		MBH	SHC	MBH	SHC	MBH	SHC	MBH	SHC	MBH	SHC	MBH	SHC	MBH	SHC	MBH	SHC	MBH	SHC	MBH	SHC	MBH	SHC		
2700	75	84.6	72.9	93.9	55.3	98.4	36.4	78.2	69.6	90.1	53.3	96.9	35.1	71.8	66.3	83.9	50.4	94.0	33.3	65.3	63.1	76.5	47.1	89.4	31.2
	80	86.8	86.8	94.4	68.5	99.6	50.0	81.8	81.8	90.5	67.5	98.0	49.7	76.4	76.4	84.3	64.7	94.5	47.5	70.9	70.9	77.1	61.4	89.6	45.3
	85	92.2	92.2	95.4	81.7	100.8	61.3	88.4	88.4	91.5	81.5	99.0	62.4	83.2	83.2	85.8	79.3	94.9	60.9	77.6	77.6	79.0	76.1	89.9	59.3
	90	96.3	96.3	96.9	94.4	102.0	72.8	93.6	93.6	93.6	93.6	99.3	73.4	89.6	89.6	89.6	89.6	95.8	74.0	84.5	84.5	84.5	84.5	90.6	73.0
3000	75	86.8	77.5	94.7	57.0	98.9	37.1	80.5	74.4	91.5	55.8	97.6	35.7	74.0	71.1	85.6	53.1	94.8	34.0	67.1	67.1	78.2	49.8	90.5	31.9
	80	90.1	90.1	95.6	71.2	100.2	50.8	85.4	85.4	92.0	71.1	98.7	50.7	79.9	79.9	86.3	68.9	95.5	49.6	74.1	74.1	79.1	65.7	90.8	47.4
	85	94.7	94.7	96.8	85.3	101.4	62.7	91.5	91.5	93.3	86.2	99.7	63.7	86.9	86.9	88.2	84.9	96.1	63.5	81.3	81.3	81.2	81.2	91.2	62.6
	90	98.3	98.3	98.3	98.3	102.7	74.8	96.2	96.2	96.1	96.1	100.3	76.2	92.7	92.7	92.7	92.7	97.1	77.5	88.0	88.0	88.0	88.0	92.2	77.4
3300	75	88.7	81.9	95.7	58.9	99.3	37.6	82.6	79.0	92.5	58.2	98.1	36.2	75.5	75.5	87.1	55.7	95.4	34.6	69.6	69.6	79.6	52.4	91.3	32.5
	80	92.3	92.3	96.5	73.7	100.7	51.5	88.4	88.4	93.2	74.4	99.3	51.7	82.9	82.9	87.9	72.8	96.1	51.0	76.9	76.9	80.8	69.8	91.7	49.5
	85	96.5	96.5	97.8	88.4	102.0	63.9	93.8	93.8	94.8	90.3	100.0	65.0	89.8	89.8	89.8	89.8	96.9	65.8	84.4	84.4	84.4	84.4	92.3	65.5
	90	99.7	99.7	99.7	99.7	103.3	76.5	98.0	98.0	98.0	98.0	101.1	78.5	94.9	94.9	94.9	94.9	98.1	80.6	90.7	90.7	90.7	90.7	93.5	81.3
3600	75	90.2	85.7	96.4	60.6	99.7	38.1	84.6	83.6	93.3	60.0	98.5	36.8	77.9	77.9	88.2	58.1	96.0	35.2	71.8	71.8	80.9	55.0	92.0	33.2
	80	94.0	94.0	97.2	75.8	101.0	52.1	90.7	90.7	94.3	77.4	99.7	52.6	85.6	85.6	89.2	76.6	96.6	52.0	79.5	79.5	82.3	73.8	92.5	51.5
	85	97.8	97.8	98.7	91.1	102.4	65.0	95.6	95.6	96.1	93.9	100.5	66.3	91.9	91.9	91.9	91.9	97.6	67.9	86.9	86.9	86.9	86.9	93.1	68.2
	90	100.8	100.8	100.8	100.8	103.7	78.1	99.3	99.3	99.3	99.3	101.7	80.7	96.6	96.6	96.6	96.6	98.9	83.4	92.7	92.7	92.7	92.7	94.6	84.9

**Notes:**

1. All capacities shown are gross and have not considered indoor fan heat. To obtain **NET** cooling capacity subtract indoor fan heat. For indoor fan heat formula, refer to appropriate airflow table notes.
2. MBH = Total Gross Capacity
3. SHC = Sensible Heat Capacity

**Performance Data**

*(8½-10 Tons Standard Efficiency)*

**Table 14. Gross Cooling Capacities 8½ Tons Three Phase Standard Efficiency T/YSC102A,3,4,W,K**

		Ambient Temperature																							
		85			95			105			115														
Air Ent Flow DB	CFM (F)	Entering Wet Bulb																							
		61			67			73			61			67			73								
		MBH	SHC	MBH	SHC	MBH	SHC	MBH	SHC	MBH	SHC	MBH	SHC	MBH	SHC	MBH	SHC	MBH	SHC	MBH	SHC	MBH	SHC	MBH	SHC
3060	75	96.3	82.3	106.6	62.7	112.5	41.5	89.0	78.5	103.2	60.6	110.9	40.0	81.8	74.9	96.6	57.5	107.6	38.1	74.9	71.3	87.6	55.2	102.5	35.8
	80	98.0	98.0	107.2	77.1	113.7	57.0	92.9	91.4	103.4	76.3	111.5	57.1	86.3	86.2	96.9	73.3	108.2	54.0	80.2	80.2	88.1	69.4	102.8	51.5
	85	103.9	103.9	108.1	91.7	114.8	69.6	100.1	100.1	104.3	91.7	112.4	70.0	94.3	94.3	98.3	89.5	108.6	68.9	87.6	87.6	89.9	85.7	103.1	67.1
	90	108.6	108.6	109.6	105.7	116.0	82.4	105.9	105.9	105.9	105.9	113.2	83.0	101.6	101.6	101.9	100.2	109.3	83.4	95.6	95.6	95.6	95.5	103.6	82.3
3400	75	98.7	87.2	107.8	65.9	113.0	42.0	91.8	83.8	104.7	63.7	111.8	40.7	84.2	80.0	98.7	60.5	108.6	38.9	76.3	76.3	89.6	58.6	103.7	36.5
	80	101.6	100.0	108.5	80.1	114.6	58.1	96.9	96.5	105.0	80.1	112.8	57.8	90.3	90.3	99.1	77.9	109.3	56.3	83.8	83.8	90.3	74.0	104.0	53.8
	85	106.8	106.8	109.6	95.7	115.8	71.4	103.6	103.6	106.2	96.7	114.0	70.7	98.7	98.7	100.9	95.5	109.8	71.7	91.7	91.7	91.7	91.7	104.3	70.7
	90	111.0	111.0	111.0	111.0	117.0	84.9	108.8	108.8	108.9	107.2	114.4	86.1	105.1	105.1	105.0	104.8	110.7	87.4	99.8	99.8	99.7	99.7	105.2	87.1
3740	75	100.7	91.7	109.2	64.5	114.0	42.8	93.8	88.7	106.1	66.5	113.5	41.7	85.4	85.4	100.4	63.3	109.4	39.6	79.4	77.5	91.3	59.4	104.6	37.2
	80	104.1	103.6	109.6	82.9	115.3	59.0	100.0	100.0	106.6	84.3	113.7	59.0	94.0	94.0	100.9	82.2	109.6	60.2	87.0	87.0	92.2	78.5	105.1	56.0
	85	108.9	108.9	110.9	99.2	116.6	73.0	106.7	106.7	108.3	102.4	114.8	74.4	102.0	102.0	102.0	102.0	110.8	74.3	95.6	95.6	96.4	93.7	105.5	73.9
	90	112.8	112.8	112.8	112.8	117.8	87.2	111.8	111.8	111.8	111.2	116.0	90.0	107.7	107.7	107.7	107.7	111.9	90.9	102.9	102.9	102.9	102.9	106.6	91.4
4080	75	102.3	95.8	110.2	66.1	114.6	43.5	95.2	95.2	106.7	68.3	113.1	42.2	88.2	88.2	101.6	65.9	110.1	40.3	81.6	80.6	92.7	62.1	105.3	38.1
	80	106.2	106.2	110.5	85.3	115.9	59.8	102.8	102.8	107.4	86.8	114.3	60.0	97.4	97.4	102.4	86.2	111.0	58.6	89.9	89.9	94.1	82.9	105.9	58.2
	85	110.5	110.5	111.9	102.3	117.2	74.4	108.3	108.3	109.2	105.1	115.5	76.3	104.5	104.5	104.4	104.4	111.5	77.2	98.7	98.7	99.0	97.4	106.4	76.8
	90	114.2	114.2	114.2	114.2	118.5	89.3	112.7	112.7	112.7	112.7	116.8	92.7	109.7	109.7	109.7	109.7	112.9	94.2	105.2	105.2	105.2	105.2	107.8	95.4

- Notes:**
1. All capacities shown are gross and have not considered indoor fan heat. To obtain **NET** cooling capacity subtract indoor fan heat. For indoor fan heat formula, refer to appropriate airflow table notes.
  2. MBH = Total Gross Capacity
  3. SHC = Sensible Heat Capacity

**Table 15. Gross Cooling Capacities 10 Tons Three Phase Standard Efficiency T/YSC120A,3,4,W,K**

		Ambient Temperature																							
		85			95			105			115														
Air Ent Flow DB	CFM (F)	Entering Wet Bulb																							
		61			67			73			61			67			73								
		MBH	SHC	MBH	SHC	MBH	SHC	MBH	SHC	MBH	SHC	MBH	SHC	MBH	SHC	MBH	SHC	MBH	SHC	MBH	SHC	MBH	SHC	MBH	SHC
3600	75	108.6	95.7	120.5	71.5	126.0	46.0	100.1	91.3	115.5	68.8	123.6	43.3	91.0	86.5	107.2	64.9	119.3	41.0	82.2	82.0	96.5	60.1	113.1	37.9
	80	112.8	112.8	121.2	89.2	127.5	65.7	106.3	106.3	116.1	88.1	124.8	62.8	98.5	98.5	108.2	84.5	120.1	60.5	90.5	90.5	97.8	79.7	113.6	57.4
	85	119.5	119.5	122.6	106.9	129.0	78.5	114.8	114.8	117.7	107.0	126.2	79.2	108.2	108.2	110.5	104.5	121.8	76.8	100.1	100.1	100.1	100.1	114.2	76.6
	90	124.3	124.3	124.6	123.6	130.4	93.6	121.0	121.0	121.0	121.0	127.6	95.7	116.0	116.0	116.0	116.0	122.0	95.1	109.4	109.4	109.4	109.4	115.3	94.5
4000	75	111.6	102.3	121.7	73.9	126.7	46.9	103.4	98.1	117.1	72.3	124.5	42.7	94.2	93.4	109.5	68.7	120.2	41.9	85.3	85.3	98.8	64.0	114.3	38.8
	80	116.7	116.7	122.6	92.7	128.2	64.5	111.1	111.1	118.0	93.0	125.7	64.2	103.4	103.4	110.8	90.4	121.4	63.2	95.0	95.0	100.6	85.8	114.9	60.3
	85	122.3	122.3	124.2	111.4	129.7	80.2	118.5	118.5	120.0	113.1	127.1	81.6	112.8	112.8	113.6	112.1	122.6	82.1	105.1	105.1	105.1	105.1	115.6	80.4
	90	126.9	126.9	126.4	126.4	131.3	96.0	123.7	123.7	123.7	123.7	128.7	99.0	119.3	119.3	119.3	119.3	124.1	100.7	113.4	113.4	113.4	113.4	117.1	100.0
4400	75	114.1	108.4	122.5	75.8	127.3	47.7	106.5	104.9	118.4	75.8	124.9	45.4	97.1	97.1	111.3	72.3	121.3	40.2	88.6	88.6	100.9	67.7	115.1	39.7
	80	119.5	119.5	123.8	96.1	128.9	65.5	114.7	114.7	119.5	97.3	126.3	69.2	107.7	107.7	112.9	95.9	122.2	64.9	99.0	99.0	103.1	91.7	115.8	63.2
	85	124.9	124.9	125.5	115.5	130.4	81.9	121.1	121.1	121.8	118.3	127.9	83.7	116.0	116.0	116.0	116.0	123.6	85.0	109.2	109.2	109.2	109.2	116.8	84.0
	90	127.9	127.9	128.0	128.0	132.0	98.3	126.1	126.1	125.6	125.6	129.5	101.8	121.7	121.7	121.7	121.7	125.3	104.7	116.2	116.2	116.2	116.2	118.5	104.7
4800	75	116.1	113.8	123.1	77.6	127.8	48.5	108.9	108.9	119.2	78.1	125.4	46.2	100.5	100.5	112.8	76.1	121.4	43.6	91.6	91.6	102.6	71.3	115.8	40.6
	80	121.4	121.4	124.5	98.6	129.4	66.4	117.3	117.3	120.8	101.1	126.9	66.5	111.1	111.1	114.6	100.9	122.9	66.4	102.5	102.5	105.4	97.5	116.5	65.7
	85	126.0	126.0	126.4	118.6	130.9	83.4	122.9	122.9	123.2	122.6	128.5	85.6	118.4	118.4	118.4	118.4	124.3	87.5	112.1	112.1	112.1	112.1	117.8	87.3
	90	129.1	129.1	129.1	129.1	132.5	100.4	127.2	127.2	126.9	126.9	130.2	104.4	124.0	124.0	123.7	123.7	126.2	108.0	118.2	118.2	118.2	118.2	119.7	108.9

- Notes:**
1. All capacities shown are gross and have not considered indoor fan heat. To obtain **NET** cooling capacity subtract indoor fan heat. For indoor fan heat formula, refer to appropriate airflow table notes.
  2. MBH = Total Gross Capacity
  3. SHC = Sensible Heat Capacity



## Performance Data

*(3 Tons High Efficiency)*

**Table 16. Gross Cooling Capacities 3 Tons 13 SEER T/YHC033A3,4,W Standard Refrigeration or Dehumidification (Hot Gas Reheat)**

		Ambient Temperature																							
		85			95			105			115														
Air Flow CFM	Ent DB (F)	Entering Wet Bulb																							
		61			67			73			61			67			73								
		MBH	SHC	MBH	SHC	MBH	SHC	MBH	SHC	MBH	SHC	MBH	SHC	MBH	SHC	MBH	SHC	MBH	SHC	MBH	SHC				
600*	75	30.8	21.6	34.9	17.8	39.2	13.7	28.9	20.4	32.8	16.6	37.0	12.5	26.9	19.1	30.6	15.3	34.7	11.3	24.8	17.8	28.4	14.1	32.3	10.0
	80	30.9	25.0	35.0	21.2	39.3	17.2	29.0	23.8	32.9	19.9	37.1	16.0	26.9	22.5	30.8	18.7	34.8	14.8	24.9	21.1	28.6	17.4	32.4	13.5
	85	31.0	28.4	35.1	24.6	39.5	20.6	29.0	27.1	33.1	23.3	37.3	19.3	27.0	25.8	30.9	22.0	35.0	18.1	25.0	24.5	28.7	20.7	32.6	16.8
	90	31.2	31.2	35.2	27.9	39.6	23.9	29.6	29.6	33.1	26.6	37.4	22.7	28.0	28.0	31.0	25.4	35.1	21.4	26.3	26.3	28.8	24.0	32.7	20.1
780*	75	33.1	24.8	37.3	19.7	41.8	14.5	30.9	23.5	35.0	18.5	39.3	13.2	28.8	22.2	32.6	17.1	36.7	12.0	26.5	20.8	30.2	15.8	34.1	10.7
	80	33.2	29.2	37.4	24.1	41.9	18.9	31.1	27.9	35.1	22.8	39.5	17.6	29.0	26.6	32.8	21.5	36.9	16.3	26.7	25.2	30.4	20.1	34.3	15.0
	85	33.4	33.4	37.5	28.4	42.1	23.2	31.6	31.6	35.3	27.1	39.6	21.9	29.8	29.8	32.9	25.8	37.0	20.6	27.9	27.9	30.5	24.4	34.4	19.3
	90	35.4	35.4	37.7	32.7	42.2	27.5	33.6	33.6	35.5	31.4	39.8	26.2	31.8	31.8	33.1	30.1	37.2	24.9	29.8	29.8	30.8	28.7	34.6	23.6
960	75	34.6	27.8	38.9	21.5	43.4	15.1	32.4	26.5	36.5	20.2	40.9	13.8	30.1	25.1	34.0	18.9	38.1	12.6	27.7	23.7	31.4	17.5	35.3	11.2
	80	35.0	33.2	39.0	26.8	43.5	20.4	32.8	31.9	36.6	25.5	41.0	19.2	30.6	30.5	34.1	24.1	38.3	17.8	28.3	28.3	31.6	22.7	35.5	16.5
	85	36.4	36.4	39.2	32.0	43.7	25.6	34.5	34.5	36.8	30.7	41.2	24.4	32.5	32.5	34.4	29.4	38.5	23.0	30.4	30.4	31.9	28.0	35.7	21.7
	90	38.6	38.6	39.6	37.3	43.9	30.8	36.7	36.7	37.3	36.0	41.4	29.5	34.6	34.6	34.9	34.7	38.6	28.2	32.5	32.5	32.5	35.9	26.8	
1080	75	35.5	29.7	39.7	22.9	44.1	15.4	33.2	28.4	37.2	21.6	41.6	14.2	30.8	27.0	34.6	20.3	38.8	12.9	28.4	25.6	32.0	18.9	35.9	11.6
	80	36.0	35.8	39.9	28.5	44.3	21.3	33.8	33.8	37.4	27.2	41.7	20.1	31.7	31.7	34.8	25.8	39.0	18.8	29.6	29.6	32.2	24.4	36.1	17.4
	85	38.1	38.1	40.1	34.4	44.5	27.2	36.0	36.0	37.7	33.1	41.9	25.9	33.9	33.9	35.2	31.7	39.2	24.6	31.8	31.8	32.6	30.3	36.3	23.2
	90	40.4	40.4	40.8	40.4	44.7	33.0	38.3	38.3	38.3	38.3	42.1	31.7	36.2	36.2	36.2	36.2	39.4	30.4	34.0	34.0	33.9	33.9	36.5	29.0
1200	75	36.2	31.6	40.4	23.7	44.8	15.7	33.8	30.2	37.8	22.4	42.2	14.5	31.4	28.8	35.2	21.0	39.4	13.2	29.0	27.4	32.5	19.6	36.4	11.9
	80	37.1	37.1	40.6	30.2	45.0	22.3	35.0	35.0	38.0	28.8	42.3	21.0	32.9	32.9	35.4	27.5	39.6	19.7	30.7	30.7	32.7	26.1	36.6	18.3
	85	39.5	39.5	41.0	36.7	45.1	28.7	37.4	37.4	38.4	35.4	42.5	27.4	35.2	35.2	35.9	34.0	39.8	26.1	33.0	33.0	33.3	32.7	36.8	24.7
	90	42.0	42.0	42.0	42.0	45.4	35.1	39.8	39.8	39.8	39.8	42.8	33.8	37.5	37.5	37.5	37.5	40.1	32.5	35.2	35.2	35.2	35.2	37.1	31.1
1320	75	36.8	33.4	40.9	24.8	45.3	16.1	34.4	32.1	38.3	23.4	42.6	14.8	32.0	30.7	35.6	22.0	39.9	13.5	29.6	29.3	32.9	20.6	36.9	12.2
	80	38.3	38.3	41.2	31.9	45.5	23.1	36.1	36.1	38.6	30.5	42.8	21.9	33.9	33.9	35.9	29.1	40.0	20.6	31.7	31.7	33.2	27.7	37.1	19.2
	85	40.8	40.8	41.7	39.0	45.7	30.2	38.6	38.6	39.2	37.7	43.0	28.9	36.3	36.3	36.6	36.3	40.2	27.5	34.0	34.0	34.0	34.0	37.3	26.2
	90	43.3	43.3	43.3	43.3	46.0	37.1	41.1	41.1	41.1	41.1	43.3	35.9	38.8	38.8	38.8	38.8	40.6	34.6	36.3	36.3	36.3	36.3	37.7	33.2
1440	75	37.4	35.2	41.4	25.8	45.8	16.4	35.0	33.9	38.7	24.4	43.0	15.1	32.6	32.5	36.0	23.0	40.2	13.8	30.1	30.1	33.2	21.6	37.2	12.5
	80	39.3	39.3	41.7	33.5	46.0	24.0	37.1	37.1	39.1	32.1	43.2	22.7	34.8	34.8	36.4	30.7	40.4	21.4	32.5	32.5	33.6	29.3	37.4	20.0
	85	41.9	41.9	42.4	41.3	46.1	31.6	39.7	39.7	39.6	39.6	43.4	30.3	37.3	37.3	37.3	37.3	40.6	29.0	34.9	34.9	34.9	34.9	37.7	27.6
	90	44.4	44.4	44.4	44.4	46.5	39.2	42.2	42.2	42.2	42.2	43.8	37.9	39.8	39.8	39.8	39.8	41.1	36.6	37.3	37.3	37.3	37.3	38.2	35.3

**Notes:**

- All capacities shown are gross and have not considered indoor fan heat. To obtain **NET** cooling capacity subtract indoor fan heat. For indoor fan heat formula, refer to appropriate airflow table notes.
  - MBH = Total Gross Capacity
  - SHC = Sensible Heat Capacity
- \*Unit applications below 960 CFM
- All heat models (gas and electric) restricted on applications below 960 CFM.
  - Dehumidification (Hot Gas Reheat) or Frostat and Crankcase Heaters are required on applications below 960 CFM.

**Performance Data**

*(4 Tons High Efficiency)*

**Table 17. Gross Cooling Capacities 4 Tons 13 SEER T/YHC043A3,4,W Standard Refrigeration or Dehumidification (Hot Gas Reheat)**

		Ambient Temperature																							
		85			95			105			115														
Air Flow CFM	Ent DB (F)	Entering Wet Bulb																							
		61	67	73	61	67	73	61	67	73	61	67	73												
		MBH	SHC	MBH	SHC	MBH	SHC	MBH	SHC	MBH	SHC	MBH	SHC	MBH	SHC	MBH	SHC								
800*	75	40.4	29.1	45.7	23.7	51.3	18.2	38.2	27.7	43.3	22.4	48.8	16.9	35.8	26.3	40.6	20.9	45.9	15.4	33.3	24.8	38.0	19.5	43.1	14.0
	80	40.5	33.8	45.8	28.4	51.5	22.8	38.3	32.4	43.4	27.0	48.9	21.5	35.9	31.0	40.8	25.5	46.0	20.0	33.4	29.5	38.1	24.1	43.2	18.6
	85	40.8	38.5	45.9	33.1	51.6	27.5	38.5	37.1	43.5	31.7	49.0	26.1	36.2	35.7	40.8	30.2	46.1	24.6	33.9	33.9	38.2	28.7	43.3	23.2
	90	42.0	42.0	46.1	37.7	51.7	32.1	40.1	40.1	43.7	36.3	49.1	30.7	38.1	38.1	41.0	34.8	46.2	29.2	36.1	36.1	38.4	33.3	43.4	27.8
1040*	75	43.3	33.5	48.8	26.4	54.6	19.2	40.8	32.1	46.2	25.0	51.8	17.8	38.2	30.6	43.2	23.5	48.6	16.3	35.5	29.1	40.4	22.0	45.5	14.9
	80	43.6	39.6	48.9	32.4	54.7	25.1	41.1	38.2	46.3	31.0	51.9	23.8	38.6	36.7	43.3	29.5	48.7	22.3	36.0	35.2	40.5	28.0	45.7	20.8
	85	44.7	44.7	49.1	38.4	54.9	31.1	42.6	42.6	46.5	37.0	52.1	29.7	40.4	40.4	43.6	35.4	48.8	28.2	38.2	38.2	40.7	33.9	45.8	26.7
	90	47.3	47.3	49.4	44.4	55.0	37.0	45.2	45.2	46.8	42.9	52.2	35.6	43.0	43.0	44.0	41.4	49.0	34.0	40.7	40.7	41.2	39.9	46.0	32.6
1280	75	45.3	37.7	50.8	28.9	56.7	20.0	42.7	36.2	48.0	27.5	53.8	18.6	40.0	34.7	44.9	25.9	50.3	17.0	37.2	33.1	41.9	24.4	47.1	15.6
	80	46.0	45.1	51.0	36.2	56.9	27.3	43.4	43.4	48.2	34.7	53.9	25.9	41.1	41.1	45.1	33.1	50.5	24.3	38.7	38.7	42.1	31.6	47.3	22.9
	85	48.5	48.5	51.3	43.5	57.0	34.5	46.2	46.2	48.6	42.0	54.1	33.1	43.9	43.9	45.5	40.4	50.6	31.5	41.4	41.4	42.6	38.9	47.5	30.0
	90	51.4	51.4	52.1	50.8	57.3	41.7	49.1	49.1	49.5	49.4	54.3	40.3	46.7	46.7	46.7	46.7	50.9	38.7	44.2	44.2	44.2	44.2	47.7	37.2
1440	75	46.3	40.3	51.5	30.3	57.4	20.3	43.7	38.8	48.7	28.9	54.3	18.9	41.0	37.3	45.7	27.4	51.2	17.5	38.1	35.8	42.7	25.9	47.9	16.0
	80	47.6	47.6	51.8	38.5	57.6	28.5	45.2	45.2	49.0	37.0	54.5	27.1	42.8	42.8	46.0	35.5	51.3	25.6	40.3	40.3	43.0	34.0	48.1	24.2
	85	50.6	50.6	52.3	46.6	57.7	36.5	48.2	48.2	49.5	45.2	54.7	35.1	45.7	45.7	46.6	43.7	51.5	33.7	43.2	43.2	43.7	42.2	48.3	32.2
	90	53.6	53.6	53.6	53.6	58.1	44.6	51.2	51.2	51.2	51.2	55.0	43.2	48.7	48.7	48.7	48.7	51.9	41.7	46.1	46.1	46.1	46.1	48.7	40.2
1600	75	47.3	42.9	52.4	31.8	58.2	20.7	44.6	41.4	49.4	30.4	55.1	19.3	41.8	39.9	46.4	28.9	51.9	17.9	39.0	38.4	43.3	27.4	48.6	16.4
	80	49.2	49.2	52.7	40.9	58.4	29.8	46.8	46.8	49.8	39.4	55.3	28.4	44.3	44.3	46.8	37.9	52.0	26.9	41.7	41.7	43.7	36.4	48.7	25.4
	85	52.4	52.4	53.4	49.9	58.6	38.7	49.9	49.9	50.6	48.5	55.5	37.3	47.4	47.4	47.7	47.0	52.3	35.8	44.7	44.7	44.7	44.7	49.0	34.3
	90	55.6	55.6	55.6	55.6	59.1	47.6	53.1	53.1	53.1	53.1	56.0	46.2	50.4	50.4	50.4	50.4	52.8	44.7	47.7	47.7	47.7	47.7	49.5	43.2
1760	75	48.2	45.5	53.0	33.3	59.0	21.2	45.5	44.0	50.1	31.8	55.8	19.8	42.7	42.5	47.0	30.3	52.5	18.3	39.9	39.9	43.8	28.8	49.1	16.8
	80	50.7	50.7	53.5	43.2	59.1	31.1	48.2	48.2	50.5	41.7	55.9	29.6	45.6	45.6	47.5	40.2	52.6	28.2	42.9	42.9	44.4	38.7	49.3	26.7
	85	54.0	54.0	54.4	53.1	59.4	40.8	51.4	51.4	51.4	51.4	56.2	39.4	48.8	48.8	48.8	48.8	52.9	37.9	46.0	46.0	46.0	46.0	49.6	36.4
	90	57.3	57.3	57.3	57.3	59.9	50.5	54.7	54.7	54.7	54.7	56.8	49.1	52.0	52.0	52.0	52.0	53.6	47.6	49.2	49.2	49.2	49.2	50.3	46.1
1920	75	49.0	48.1	53.6	34.7	59.6	21.6	46.1	46.1	50.6	33.3	56.3	20.2	43.6	43.6	47.5	31.8	53.0	18.7	40.9	40.9	44.3	30.2	49.5	17.2
	80	52.0	52.0	54.2	45.4	59.7	32.3	49.4	49.4	51.2	44.0	56.5	30.9	46.8	46.8	48.1	42.5	53.2	29.4	44.0	44.0	45.0	41.0	49.7	27.9
	85	55.4	55.4	55.3	55.3	60.0	42.9	52.7	52.7	52.7	52.7	56.9	41.5	50.0	50.0	50.0	50.0	53.5	40.0	47.2	47.2	47.2	47.2	50.1	38.5
	90	58.8	58.8	58.8	58.8	60.7	53.4	56.1	56.1	56.1	56.1	57.6	52.0	53.3	53.3	53.3	53.3	54.4	50.6	50.4	50.4	50.4	50.4	51.0	49.1

**Notes:**

- All capacities shown are gross and have not considered indoor fan heat. To obtain **NET** cooling capacity subtract indoor fan heat. For indoor fan heat formula, refer to appropriate airflow table notes.
  - MBH = Total Gross Capacity
  - SHC = Sensible Heat Capacity
- \*Unit applications below 1280 CFM
- All heat models (gas and electric) restricted on applications below 1280 CFM.
  - Dehumidification (Hot Gas Reheat) or Frostat and Crankcase Heaters are required on applications below 1280 CFM.

## Performance Data

*(5 Tons High Efficiency)*

**Table 18. Gross Cooling Capacities 5 Tons 13 SEER T/YHC063A3,4,W Standard Refrigeration or Dehumidification (Hot Gas Reheat)**

		Ambient Temperature																							
		85			95			105			115														
Air Flow CFM	Ent DB (F)	Entering Wet Bulb																							
		61	67	73	61	67	73	61	67	73	61	67	73												
		MBH	SHC	MBH	SHC	MBH	SHC	MBH	SHC	MBH	SHC	MBH	SHC	MBH	SHC	MBH	SHC	MBH	SHC						
1000*	75	50.7	36.2	57.0	29.4	63.7	22.6	48.1	34.6	54.2	27.9	60.7	21.0	45.5	32.9	51.3	26.2	57.5	19.4	42.7	31.2	48.2	24.5	54.1	17.7
	80	50.8	41.8	57.1	35.1	63.8	28.2	48.3	40.2	54.4	33.5	60.8	26.6	45.6	38.6	51.5	31.9	57.6	25.0	42.9	36.8	48.4	30.1	54.2	23.3
	85	51.0	47.5	57.2	40.7	64.0	33.8	48.6	45.9	54.5	39.1	61.0	32.2	46.0	44.2	51.6	37.4	57.8	30.6	43.3	42.5	48.5	35.7	54.4	28.8
	90	52.2	52.2	57.4	46.3	64.1	39.4	50.1	50.1	54.6	44.7	61.1	37.8	47.8	47.8	51.7	43.0	57.9	36.1	45.5	45.5	48.7	41.3	54.5	34.4
1300*	75	54.3	41.5	60.7	32.7	67.6	23.8	51.5	39.9	57.7	31.0	64.3	22.1	48.6	38.1	54.5	29.3	60.8	20.4	45.5	36.4	51.1	27.5	57.0	18.7
	80	54.6	48.8	60.9	40.0	67.8	31.0	51.9	47.1	57.9	38.3	64.5	29.3	49.0	45.4	54.7	36.6	60.9	27.6	46.0	43.6	51.3	34.8	57.2	25.9
	85	55.6	55.6	61.1	47.2	67.9	38.2	53.2	53.2	58.1	45.5	64.6	36.5	50.7	50.7	54.9	43.7	61.1	34.8	48.1	48.1	51.5	41.9	57.4	33.0
	90	58.8	58.8	61.5	54.4	68.1	45.3	56.3	56.3	58.5	52.7	64.8	43.6	53.7	53.7	55.3	50.9	61.3	41.9	51.0	51.0	52.0	49.1	57.5	40.1
1600	75	56.8	46.5	63.2	35.6	70.2	24.7	53.9	44.9	60.0	33.9	66.6	23.0	50.8	43.1	56.6	32.2	62.9	21.3	47.5	41.3	53.0	30.4	58.9	19.5
	80	57.6	55.5	63.4	44.5	70.3	33.5	54.7	53.8	60.2	42.7	66.8	31.8	51.6	51.6	56.8	41.0	63.0	30.1	48.8	48.8	53.2	39.1	59.1	28.3
	85	60.3	60.3	63.8	53.2	70.5	42.2	57.7	57.7	60.6	51.5	67.0	40.5	54.9	54.9	57.3	49.7	63.2	38.8	52.0	52.0	53.7	47.9	59.3	36.9
	90	63.8	63.8	64.7	62.1	70.8	50.9	61.1	61.1	61.6	60.4	67.3	49.2	58.2	58.2	58.2	58.2	63.5	47.4	55.1	55.1	55.1	55.1	59.6	45.6
1800	75	58.1	49.6	64.5	37.5	71.4	25.2	55.1	48.2	61.1	35.8	67.8	23.5	51.9	46.3	57.6	34.0	63.9	21.8	48.6	44.5	53.9	32.2	59.8	20.0
	80	59.3	59.3	64.7	47.4	71.6	35.1	56.6	56.6	61.4	45.6	67.9	33.4	53.8	53.8	57.9	43.8	64.1	31.6	50.8	50.8	54.2	42.0	60.0	29.8
	85	62.9	62.9	65.3	57.2	71.8	44.9	60.1	60.1	62.0	55.4	68.2	43.1	57.2	57.2	58.6	53.6	64.3	41.3	54.1	54.1	55.0	51.8	60.2	39.5
	90	66.5	66.5	66.5	66.5	72.2	54.6	63.7	63.7	63.7	63.7	68.5	52.9	60.6	60.6	60.6	60.6	64.7	51.0	57.4	57.4	57.4	57.4	60.7	49.1
2000	75	59.3	51.6	65.9	38.8	73.0	25.8	55.9	49.6	62.1	36.9	69.0	23.9	52.3	47.6	58.3	34.8	64.9	22.0	48.7	45.5	54.4	32.8	60.8	20.1
	80	60.9	60.9	66.1	49.3	73.2	36.4	57.9	57.9	62.4	47.3	69.2	34.5	54.7	54.7	58.6	45.3	65.2	32.5	51.4	51.4	54.7	43.2	61.0	30.5
	85	64.8	64.8	66.9	59.8	73.5	46.9	61.6	61.6	63.2	57.8	69.5	44.9	58.4	58.4	59.5	55.8	65.4	42.9	55.0	55.0	55.7	53.8	61.3	40.9
	90	68.6	68.6	68.6	68.6	73.8	57.1	65.4	65.4	65.3	65.3	69.9	55.1	62.1	62.1	62.0	62.0	65.9	53.2	58.7	58.7	58.7	58.7	61.8	51.2
2200	75	60.4	54.5	66.7	40.5	73.8	26.4	56.9	52.4	62.9	38.5	69.8	24.5	53.3	50.4	59.0	36.5	65.7	22.5	49.6	48.3	55.1	34.4	61.5	20.5
	80	62.7	62.7	67.1	51.8	74.1	37.8	59.5	59.5	63.3	49.8	70.0	35.9	56.3	56.3	59.4	47.8	65.9	33.9	52.9	52.9	55.5	45.8	61.7	31.9
	85	66.7	66.7	68.0	63.3	74.4	49.2	63.4	63.4	64.3	61.3	70.3	47.2	60.1	60.1	60.6	59.3	66.2	45.2	56.7	56.7	56.6	56.6	62.0	43.2
	90	70.6	70.6	70.6	70.6	74.9	60.3	67.3	67.3	67.3	67.3	70.8	58.3	63.9	63.9	63.9	63.9	66.8	56.4	60.4	60.4	60.4	60.4	62.7	54.4
2400	75	61.3	57.2	67.5	42.1	74.6	26.9	57.8	55.2	63.6	40.1	70.5	24.9	54.2	53.2	59.7	38.0	66.3	22.9	50.4	50.4	55.7	36.0	62.1	21.0
	80	64.3	64.3	67.9	54.3	74.9	39.2	61.0	61.0	64.1	52.3	70.7	37.2	57.7	57.7	60.2	50.3	66.6	35.2	54.2	54.2	56.2	48.2	62.3	33.2
	85	68.4	68.4	69.1	66.7	75.1	51.4	65.0	65.0	65.4	64.8	71.0	49.4	61.6	61.6	61.6	61.6	66.8	47.4	58.1	58.1	58.1	58.1	62.6	45.4
	90	72.4	72.4	72.4	72.4	75.8	63.5	69.0	69.0	69.0	69.0	71.7	61.5	65.5	65.5	65.5	65.5	67.6	59.5	61.9	61.9	61.9	61.9	63.5	57.5

**Notes:**

- All capacities shown are gross and have not considered indoor fan heat. To obtain **NET** cooling capacity subtract indoor fan heat. For indoor fan heat formula, refer to appropriate airflow table notes.
  - MBH = Total Gross Capacity
  - SHC = Sensible Heat Capacity
- \*Unit applications below 1600 CFM
- All heat models (gas and electric) restricted on applications below 1600 CFM.
  - Dehumidification (Hot Gas Reheat) or Frostat and Crankcase Heaters are required on applications below 1600 CFM.

## Performance Data

*(6 Tons High Efficiency)*

**Table 19. Gross Cooling Capacities 6 Tons Three Phase Standard Refrigeration Option High Efficiency T/YHC072A3,4,W**

		Ambient Temperature																							
		85			95			105			115														
Air Ent Flow DB	CFM (F)	Entering Wet Bulb																							
		61	67	73	61	67	73	61	67	73	61	67	73												
		MBH	SHC	MBH	SHC	MBH	SHC	MBH	SHC	MBH	SHC	MBH	SHC	MBH	SHC	MBH	SHC	MBH	SHC						
2160	75	67.3	56.6	73.6	42.5	74.5	27.6	61.6	53.5	71.8	41.9	75.1	26.6	55.8	50.4	66.8	38.7	74.1	25.3	49.8	47.2	59.9	36.3	71.3	23.5
	80	68.7	68.2	73.8	51.7	75.4	37.0	63.6	63.6	72.0	52.1	76.0	38.1	58.9	58.9	66.9	49.7	74.7	36.4	54.1	54.1	60.2	46.5	71.5	34.5
	85	72.2	72.2	74.5	61.4	76.2	44.5	69.2	69.2	72.5	62.8	76.8	46.1	64.6	64.6	67.8	60.9	75.0	46.2	59.5	59.5	61.3	57.7	71.7	45.4
	90	74.7	74.7	75.3	70.6	77.0	51.9	73.4	73.4	73.7	73.2	77.7	55.1	70.1	70.1	70.1	70.1	75.6	56.1	65.4	65.4	65.4	65.4	72.1	55.8
2400	75	69.0	60.1	74.0	43.3	74.5	27.9	63.5	57.2	72.7	43.1	75.2	27.0	57.5	54.0	68.4	40.9	74.5	25.7	51.8	51.0	61.5	37.6	72.0	24.0
	80	70.7	70.7	74.3	52.9	75.4	37.2	66.8	66.8	73.0	54.6	76.2	37.8	61.9	61.9	68.7	53.0	75.1	37.4	56.7	56.7	61.9	49.8	72.4	36.1
	85	73.8	73.8	75.0	63.0	76.2	44.9	71.9	71.9	73.8	66.0	77.1	47.0	67.9	67.9	69.7	65.4	75.5	47.5	62.7	62.7	63.6	62.4	72.6	47.7
	90	75.6	75.6	75.9	72.4	77.0	52.5	75.2	75.2	75.1	75.1	78.0	56.3	72.8	72.8	72.7	72.7	76.4	58.2	68.8	68.8	68.8	68.8	73.2	59.0
2640	75	70.3	63.2	74.2	43.9	74.6	28.3	65.2	60.8	73.2	44.5	75.4	27.4	59.2	57.7	69.6	42.9	74.7	26.2	53.2	53.2	62.9	39.8	72.5	24.6
	80	72.3	72.3	74.5	53.9	75.4	37.4	69.5	69.5	73.8	56.7	76.3	38.2	64.6	64.6	70.0	56.1	75.6	38.5	59.2	59.2	63.5	53.0	73.0	37.7
	85	74.7	74.7	75.3	64.3	76.2	45.2	73.7	73.7	74.7	68.7	77.3	47.6	70.5	70.5	71.3	69.3	76.1	48.9	65.6	65.6	65.6	65.6	73.4	49.7
	90	76.1	76.1	76.2	73.6	76.9	53.0	76.2	76.2	76.2	76.2	78.1	57.2	74.5	74.5	74.5	74.5	76.9	59.9	71.2	71.2	71.2	71.2	74.1	61.7
2880	75	71.3	65.8	74.3	44.4	74.6	28.7	66.8	64.4	73.7	45.6	75.5	27.8	60.5	60.5	70.6	44.8	74.9	26.6	55.1	55.1	64.1	41.8	72.9	25.0
	80	73.3	73.3	74.7	54.8	75.4	37.6	71.4	71.4	74.4	58.5	76.4	38.5	67.0	67.0	71.0	58.9	75.9	39.1	61.4	61.4	64.9	56.2	73.3	38.6
	85	75.1	75.1	75.5	65.3	76.2	45.6	74.8	74.8	75.4	70.8	77.4	48.2	72.4	72.4	72.4	72.4	76.4	49.9	68.2	68.2	68.1	68.1	74.0	51.5
	90	76.3	76.3	76.3	74.5	76.9	53.5	76.9	76.9	76.9	76.9	78.2	58.0	75.7	75.7	75.7	75.7	77.2	61.3	72.9	72.9	72.9	72.9	74.8	64.1

**Notes:**

1. All capacities shown are gross and have not considered indoor fan heat. To obtain **NET** cooling capacity subtract indoor fan heat. For indoor fan heat formula, refer to appropriate airflow table notes.
2. MBH = Total Gross Capacity
3. SHC = Sensible Heat Capacity

**Table 20. Gross Cooling Capacities 7½ Tons Three Phase Dual Compressors Standard Refrigeration Option High Efficiency T/YHC092A3,4,W**

		Ambient Temperature																							
		85			95			105			115														
Air Ent Flow DB	CFM (F)	Entering Wet Bulb																							
		61	67	73	61	67	73	61	67	73	61	67	73												
		MBH	SHC	MBH	SHC	MBH	SHC	MBH	SHC	MBH	SHC	MBH	SHC	MBH	SHC	MBH	SHC	MBH	SHC						
2700	75	85.7	72.4	95.8	56.8	99.9	37.1	79.3	69.3	92.0	53.7	98.8	35.8	72.8	66.0	85.9	50.8	96.1	34.2	66.1	62.6	78.5	49.1	91.8	32.2
	80	87.5	87.0	96.2	68.5	101.1	50.4	81.8	81.8	92.4	67.4	99.6	50.2	76.6	76.6	86.2	64.6	96.7	48.0	71.1	71.1	79.0	61.4	92.0	45.8
	85	92.8	92.8	97.0	81.6	102.3	61.3	88.5	88.5	93.1	81.1	100.3	61.3	83.4	83.4	87.1	78.6	97.0	60.9	77.9	77.9	80.3	75.4	92.3	59.4
	90	97.2	97.2	98.3	94.2	103.5	72.4	94.3	94.3	94.3	94.3	101.1	73.1	90.0	90.0	90.0	90.0	97.8	73.7	84.9	84.9	84.9	84.9	92.9	72.7
3000	75	87.9	77.0	96.6	57.3	100.4	37.6	81.5	73.7	93.5	56.1	99.4	36.4	74.9	70.5	87.8	53.4	96.9	34.8	67.4	67.4	80.5	50.2	92.8	32.8
	80	90.5	90.5	97.4	71.2	101.6	51.1	85.6	85.6	94.0	71.0	100.4	50.9	80.2	80.2	88.2	68.7	97.3	49.8	74.5	74.5	81.0	65.5	93.2	47.9
	85	95.6	95.6	98.4	85.1	102.9	62.5	92.2	92.2	95.0	85.8	101.3	63.3	87.3	87.3	89.5	84.1	98.1	63.3	81.8	81.8	82.9	81.2	93.6	62.5
	90	99.4	99.4	99.9	98.1	104.1	74.1	97.2	97.2	97.2	97.2	102.1	75.5	93.6	93.6	93.5	93.5	99.1	77.0	88.8	88.8	88.7	88.7	94.4	76.9
3300	75	89.8	81.3	97.5	59.0	100.7	38.1	83.6	78.2	94.6	58.3	99.8	37.1	77.0	75.0	89.2	55.9	97.5	35.4	70.0	70.0	82.1	52.8	93.6	33.4
	80	93.2	93.2	98.3	73.5	102.0	51.7	88.9	88.9	95.2	74.2	101.0	52.0	83.4	83.4	89.8	72.6	97.9	50.6	77.6	77.6	82.8	69.5	94.1	49.9
	85	97.6	97.6	99.4	88.0	103.3	67.9	94.9	94.9	96.5	90.0	101.9	64.8	90.5	90.5	91.7	89.4	99.0	67.3	85.2	85.2	85.1	85.1	94.7	65.2
	90	100.9	100.9	100.9	100.9	104.6	75.6	99.2	99.2	99.2	99.2	102.8	77.7	96.1	96.1	96.1	96.1	100.1	80.0	91.8	91.8	91.8	91.8	95.7	80.7
3600	75	91.5	85.3	98.2	60.6	101.0	38.6	85.5	82.6	95.4	60.2	100.2	37.5	78.5	78.5	90.5	58.3	98.0	35.9	72.4	72.4	83.4	55.2	94.3	34.0
	80	95.2	95.2	99.0	75.4	102.3	56.8	91.5	91.5	96.3	77.2	101.5	52.7	86.3	86.3	91.3	76.3	98.4	51.4	80.4	80.4	84.4	73.4	94.7	51.4
	85	99.1	99.1	100.2	90.6	103.6	69.8	96.9	96.9	97.8	93.6	102.4	66.1	93.1	93.1	93.1	93.1	99.7	69.8	88.0	88.0	87.9	87.9	95.6	67.8
	90	101.9	101.9	101.9	101.9	105.0	76.9	100.7	100.7	100.7	100.7	103.4	79.6	98.0	98.0	97.9	97.9	100.8	82.5	94.0	94.0	94.0	94.0	96.7	84.1

**Notes:**

1. All capacities shown are gross and have not considered indoor fan heat. To obtain **NET** cooling capacity subtract indoor fan heat. For indoor fan heat formula, refer to appropriate airflow table notes.
2. MBH = Total Gross Capacity
3. SHC = Sensible Heat Capacity

## Performance Data

*(7½ Tons High Efficiency)*

**Table 21. Gross Cooling Capacities 7½ Tons Three Phase Dehumidification (Hot Gas Reheat) or TXV Option High Efficiency T/YHC092A,3,4,W**

		Ambient Temperature																							
		85						95						105						115					
Air Flow CFM	Ent DB (F)	Entering Wet Bulb																							
		61		67		73		61		67		73		61		67		73		61		67		73	
		MBH	SHC	MBH	SHC	MBH	SHC	MBH	SHC	MBH	SHC	MBH	SHC	MBH	SHC	MBH	SHC	MBH	SHC	MBH	SHC	MBH	SHC	MBH	SHC
1500*	75	76.3	54.5	85.6	45.2	95.8	34.8	72.9	52.4	81.9	43.2	91.7	32.8	69.2	50.2	77.9	41.1	87.3	30.8	65.3	48.0	73.7	38.9	82.8	28.6
	80	76.5	62.6	85.8	53.0	95.9	43.1	73.0	60.5	82.0	50.9	91.8	41.1	69.3	58.3	78.0	48.7	87.4	39.0	65.4	56.0	73.8	46.5	82.9	36.8
	85	76.6	70.6	85.9	61.0	96.0	51.1	73.1	68.4	82.1	58.9	91.9	49.0	69.4	66.2	78.1	56.7	87.5	46.9	65.6	63.8	73.9	54.4	83.0	44.7
	90	77.3	77.3	86.1	69.0	96.1	59.0	74.5	74.5	82.3	66.9	92.0	57.0	71.5	71.5	78.3	64.6	87.7	54.8	68.3	68.3	74.0	62.3	83.1	52.6
1950*	75	81.6	61.9	91.2	49.4	101.6	36.5	77.7	59.7	87.0	47.2	97.1	34.5	73.7	57.5	82.6	45.0	92.3	32.3	69.4	55.1	78.0	42.7	87.3	30.1
	80	81.9	72.2	91.3	59.6	101.7	47.0	78.1	70.0	87.2	57.5	97.2	44.8	74.0	67.7	82.8	55.2	92.4	42.6	69.8	65.4	78.2	52.9	87.4	40.4
	85	82.3	82.3	91.6	69.9	101.9	57.1	79.2	79.2	87.4	67.7	97.3	55.0	75.8	75.8	83.0	65.4	92.6	52.8	72.3	72.3	78.4	63.1	87.6	50.5
	90	86.9	86.9	91.9	80.0	102.0	67.2	83.6	83.6	87.8	77.8	97.5	65.1	80.2	80.2	83.4	75.5	92.7	62.8	76.5	76.5	78.9	73.2	87.8	60.6
2400	75	85.2	68.7	94.9	53.4	105.5	37.9	81.1	66.5	90.5	51.2	100.7	35.8	76.8	64.2	85.8	48.9	95.6	33.6	72.3	61.8	80.9	46.6	90.3	31.4
	80	86.0	81.3	95.1	65.8	105.6	50.4	82.0	79.1	90.7	63.6	100.8	48.2	77.9	76.9	86.0	61.4	95.7	46.0	73.4	73.4	81.2	59.0	90.4	43.7
	85	89.2	89.2	95.5	78.2	105.8	62.7	85.7	85.7	91.1	76.0	101.0	60.5	82.0	82.0	86.5	73.7	95.9	58.2	78.1	78.1	81.6	71.3	90.6	55.9
	90	94.2	94.2	96.4	90.6	106.1	74.9	90.6	90.6	92.1	88.4	101.3	72.8	86.8	86.8	87.6	86.2	96.2	70.4	82.8	82.8	82.8	82.8	90.9	68.1
2700	75	87.1	73.0	96.8	57.3	107.4	38.7	82.9	70.9	92.2	55.1	102.5	36.6	78.5	68.6	87.4	52.9	97.2	34.4	73.9	66.2	82.3	50.6	91.8	32.2
	80	88.4	87.3	97.0	69.7	107.6	52.5	84.2	84.2	92.5	67.5	102.6	50.4	80.4	80.4	87.7	65.2	97.4	48.1	76.4	76.4	82.7	62.8	91.9	45.8
	85	92.9	92.9	97.6	83.5	107.8	66.2	89.3	89.3	93.1	81.3	102.8	64.0	85.4	85.4	88.4	79.0	97.6	61.8	81.3	81.3	83.4	76.7	92.1	59.4
	90	98.2	98.2	99.1	97.6	108.1	79.8	94.4	94.4	94.4	94.4	103.2	77.6	90.4	90.4	90.4	90.4	98.0	75.3	86.2	86.2	86.2	86.2	92.5	73.0
3000	75	88.7	77.2	98.3	58.4	109.0	39.5	84.5	75.0	93.6	56.1	103.9	37.3	80.0	72.7	88.7	53.8	98.6	35.1	75.3	70.3	83.5	51.4	93.0	32.8
	80	90.8	90.8	98.7	73.5	109.2	54.6	87.0	87.0	94.0	71.3	104.1	52.4	83.1	83.1	89.1	69.0	98.8	50.2	78.9	78.9	84.0	66.6	93.2	47.9
	85	96.2	96.2	99.5	88.8	109.5	69.7	92.4	92.4	94.9	86.6	104.4	67.5	88.3	88.3	90.1	84.3	99.0	65.2	84.0	84.0	85.1	81.9	93.4	62.9
	90	101.7	101.7	101.7	101.7	109.9	84.6	97.8	97.7	97.7	97.7	104.8	82.4	93.6	93.6	93.5	93.5	99.5	80.2	89.1	89.1	89.1	89.1	93.9	77.8
3300	75	90.2	81.4	99.7	60.7	110.4	40.1	85.9	79.1	94.8	58.5	105.2	37.9	81.4	76.8	89.8	56.1	99.7	35.7	76.7	74.4	84.6	53.8	94.0	33.4
	80	93.4	93.4	100.1	77.3	110.6	56.7	89.5	89.5	95.3	75.0	105.4	54.5	85.5	85.5	90.3	72.7	99.9	52.2	81.1	81.1	85.1	70.3	94.2	49.9
	85	99.1	99.1	101.2	94.0	110.9	73.1	95.1	95.1	96.6	91.8	105.6	70.8	90.8	90.8	91.7	89.5	100.2	68.6	86.4	86.4	86.4	86.4	94.5	66.1
	90	104.8	104.8	104.8	104.8	111.4	89.4	100.7	100.7	100.6	100.6	106.2	87.2	96.3	96.3	96.3	96.3	100.8	84.9	91.7	91.7	91.7	91.7	95.2	82.5
3600	75	91.6	85.5	100.8	63.0	111.5	40.8	87.2	83.2	95.9	60.7	106.2	38.6	82.0	82.0	90.8	58.4	100.6	36.3	77.7	77.7	85.5	56.0	94.9	34.0
	80	95.8	95.8	101.3	80.9	111.7	58.6	91.8	91.8	96.5	78.7	106.4	56.4	87.5	87.5	91.4	76.3	100.8	54.1	83.1	83.1	86.1	74.0	95.0	51.8
	85	101.6	101.6	102.8	99.1	112.0	76.3	97.5	97.5	97.4	97.4	106.8	74.2	93.1	93.1	93.0	93.0	101.2	71.9	88.5	88.5	88.5	88.5	95.4	69.4
	90	107.5	107.5	107.5	107.5	112.8	94.0	103.2	103.2	103.2	103.2	107.5	91.8	98.7	98.7	98.7	98.7	102.1	89.5	93.9	93.9	93.9	93.9	96.4	87.2

- Notes:**
- All capacities shown are gross and have not considered indoor fan heat. To obtain **NET** cooling capacity subtract indoor fan heat. For indoor fan heat formula, refer to appropriate airflow table notes.
  - MBH = Total Gross Capacity
  - SHC = Sensible Heat Capacity
- \*For 1500 and 1950 CFM - Unit applications below 320 CFM/Ton are only applicable to T\_C models only (No Gas Heat). See below for restrictions:
- Electric heaters restricted on applications below 320 CFM/Ton.
  - Dehumidification (Hot Gas Reheat) or TXV with Froststat and Crankcase Heaters are required on applications below 320 CFM/Ton.

## Performance Data

*(8½ Tons High Efficiency)*

**Table 22. Gross Cooling Capacities 8½ Tons Three Phase Standard Refrigeration Option High Efficiency T/YHC102A3,4,W**

Air Ent Flow DB		Ambient Temperature																							
		85			95			105			115														
		Entering Wet Bulb																							
CFM (F)	61	67	73	61	67	73	61	67	73	61	67	73	61	67	73										
	MBH	SHC	MBH	SHC	MBH	SHC	MBH	SHC	MBH	SHC	MBH	SHC	MBH	SHC	MBH	SHC									
3060	75	94.0	81.8	105.7	62.8	110.8	40.9	86.3	77.8	100.7	59.7	109.7	39.3	79.0	74.2	92.4	56.0	105.5	37.1	71.8	70.5	84.0	53.1	99.6	34.6
	80	96.9	96.9	106.2	77.6	112.0	56.0	90.6	90.6	101.1	75.9	110.1	55.4	84.5	84.5	92.9	72.2	106.1	53.2	78.3	78.3	84.7	68.5	99.8	50.6
	85	103.5	103.5	107.2	92.9	113.2	68.7	98.6	98.6	102.2	92.1	111.6	70.3	92.1	92.1	94.5	88.8	106.4	68.8	85.8	85.8	86.7	85.2	100.0	66.5
	90	108.4	108.4	109.0	107.7	114.4	81.6	105.0	105.0	105.0	105.0	112.6	84.9	99.9	99.9	99.9	99.9	107.3	83.9	93.5	93.5	93.5	93.5	100.8	82.6
3400	75	96.6	87.2	107.1	64.7	111.4	41.5	88.7	83.3	102.4	62.6	110.7	40.1	81.4	79.6	94.4	59.1	106.6	37.9	74.2	74.2	85.9	55.4	101.1	35.5
	80	100.9	100.9	107.7	81.0	112.7	56.9	94.9	94.9	103.0	80.4	111.7	57.5	88.3	88.3	95.2	77.1	107.3	55.7	81.8	81.8	86.8	73.4	101.4	53.1
	85	106.6	106.6	108.9	97.4	114.0	70.2	102.6	102.6	104.4	97.8	112.8	72.9	96.5	96.5	97.6	95.6	108.0	72.4	89.9	89.9	89.8	89.8	101.8	70.8
	90	110.8	110.8	110.8	110.8	115.3	83.8	108.1	108.1	108.1	108.1	114.0	88.5	103.8	103.8	103.8	103.8	108.9	88.3	97.8	97.8	97.8	97.8	102.8	87.9
3740	75	98.9	92.5	107.4	65.9	112.0	42.2	91.2	88.7	103.7	65.4	111.1	40.7	83.5	83.5	96.3	62.2	107.5	38.7	76.9	76.9	87.5	58.4	102.2	36.2
	80	103.7	103.7	108.8	84.0	113.3	57.7	98.7	98.7	104.5	84.5	112.4	58.7	91.7	91.7	97.3	81.9	108.3	57.6	85.0	85.0	88.8	78.2	102.6	55.5
	85	108.8	108.8	110.1	100.9	114.6	76.9	105.4	105.4	106.4	103.0	113.7	75.1	100.2	100.2	100.2	100.2	109.3	75.7	93.4	93.4	93.4	93.4	103.1	74.4
	90	112.3	112.3	112.1	112.1	115.9	85.7	110.4	110.4	110.4	110.4	114.9	91.4	106.5	106.5	106.5	106.5	110.2	92.3	101.3	101.3	101.3	101.3	104.4	92.7
4080	75	100.9	97.3	108.1	67.4	112.5	42.9	93.1	93.1	104.7	67.9	111.5	41.4	86.2	86.2	97.8	65.2	108.2	39.4	79.4	79.4	88.8	61.3	103.0	36.9
	80	105.9	105.9	109.5	86.2	113.8	58.4	101.6	101.6	105.8	88.2	112.8	59.6	94.9	94.9	99.1	86.5	109.2	59.6	87.9	87.9	90.6	82.8	103.5	57.8
	85	110.2	110.2	110.9	103.4	115.1	79.5	107.6	107.6	107.6	107.6	114.1	76.6	103.0	103.0	103.0	103.0	109.9	77.6	96.6	96.6	96.6	96.6	104.2	77.7
	90	112.9	112.9	112.9	112.9	116.5	87.5	112.2	112.2	112.2	112.2	115.4	93.4	108.6	108.6	108.6	108.6	111.3	95.9	103.9	103.9	103.9	103.9	105.8	97.0

**Notes:**

- All capacities shown are gross and have not considered indoor fan heat. To obtain **NET** cooling capacity subtract indoor fan heat. For indoor fan heat formula, refer to appropriate airflow table notes.
- MBH = Total Gross Capacity
- SHC = Sensible Heat Capacity

**Performance Data**

*(8½ Tons High Efficiency)*

**Table 23. Gross Cooling Capacities 8½ Tons Three Phase Dehumidification (Hot Gas Reheat) or TXV Option High Efficiency T/YHC102A,3,4,W**

Air Ent Flow DB CFM (F)		Ambient Temperature																							
		85						95						105						115					
		Entering Wet Bulb																							
		61		67		73		61		67		73		61		67		73		61		67		73	
		MBH	SHC	MBH	SHC	MBH	SHC	MBH	SHC	MBH	SHC	MBH	SHC	MBH	SHC	MBH	SHC	MBH	SHC	MBH	SHC	MBH	SHC	MBH	SHC
1700*	75	84.4	60.9	94.7	49.8	105.6	38.0	80.3	58.5	90.3	47.5	100.8	35.7	75.9	56.0	85.6	45.0	95.7	33.3	71.3	53.3	80.6	42.4	90.3	30.8
	80	84.5	70.3	94.8	59.1	105.8	47.6	80.4	67.9	90.4	56.7	100.9	45.2	76.1	65.3	85.7	54.1	95.9	42.7	71.5	62.6	80.7	51.5	90.5	40.2
	85	84.8	79.7	94.9	68.4	105.9	56.8	80.8	77.3	90.6	66.0	101.1	54.4	76.5	74.7	85.9	63.4	96.0	51.9	72.2	71.0	80.9	60.8	90.6	49.3
	90	87.0	87.0	95.1	77.7	106.0	66.0	83.6	83.6	90.7	75.2	101.2	63.6	80.0	80.0	86.0	72.6	96.1	61.1	76.2	76.2	81.0	70.0	90.8	58.5
2210*	75	90.0	69.6	100.5	54.9	111.8	39.9	85.6	67.0	95.7	52.4	106.5	37.5	80.8	64.4	90.6	49.8	100.9	35.0	75.8	61.6	85.1	47.1	95.1	32.4
	80	90.5	81.7	100.7	66.8	111.9	51.9	86.1	79.2	95.9	64.3	106.7	49.5	81.5	76.6	90.8	61.7	101.1	47.0	76.6	73.8	85.3	59.0	95.3	44.3
	85	92.3	92.3	101.0	78.8	112.1	63.8	88.6	88.6	96.1	76.3	106.8	61.3	84.6	84.6	91.0	73.6	101.3	58.7	80.3	80.3	85.6	70.9	95.4	56.1
	90	97.5	97.5	101.5	90.7	112.3	75.6	93.6	93.6	96.7	88.2	107.0	73.1	89.5	89.5	91.7	87.1	101.5	70.5	85.1	85.1	86.4	82.9	95.6	67.9
2720	75	94.0	77.6	104.4	59.5	115.8	41.4	89.3	75.1	99.3	57.0	110.2	38.9	84.3	72.4	93.8	54.4	104.3	36.4	79.0	69.6	88.1	51.7	98.2	33.8
	80	95.2	92.6	104.7	74.1	116.0	55.9	90.7	90.1	99.5	71.5	110.4	53.4	86.0	86.0	94.1	68.9	104.5	50.9	81.4	81.4	88.4	66.2	98.4	48.2
	85	99.8	99.8	105.2	88.7	116.2	70.3	95.7	95.7	100.1	86.1	110.6	67.8	91.3	91.3	94.7	83.5	104.7	65.2	86.6	86.6	89.1	80.7	98.6	62.5
	90	105.4	105.4	106.5	103.4	116.5	84.7	101.1	101.1	101.6	100.9	110.9	82.1	96.6	96.6	96.6	96.6	105.1	79.5	91.8	91.8	91.8	91.8	98.9	76.9
3060	75	96.1	82.8	106.4	63.2	117.8	42.2	91.3	80.2	101.0	60.7	112.1	39.8	86.2	77.5	95.4	58.1	106.0	37.2	80.8	74.7	89.6	55.4	99.7	34.6
	80	98.1	98.1	106.7	78.8	118.1	58.5	93.8	93.8	101.4	76.2	112.2	55.9	89.3	89.3	95.8	73.5	106.2	53.3	84.6	84.6	90.0	70.8	99.9	50.7
	85	103.8	103.8	107.5	95.1	118.3	74.5	99.5	99.5	102.3	92.5	112.5	72.0	94.8	94.8	96.9	89.9	106.4	69.4	89.9	89.9	91.2	87.2	100.1	66.7
	90	109.7	109.7	109.7	109.7	118.7	90.6	105.2	105.2	105.2	105.2	112.9	88.1	100.4	100.4	100.4	100.4	106.9	85.4	95.4	95.4	95.4	95.4	100.7	82.7
3400	75	97.9	87.9	108.0	65.4	119.4	43.1	93.0	85.3	102.5	62.8	113.5	40.6	87.8	82.6	96.8	60.1	107.4	38.1	82.5	79.9	90.8	57.4	100.9	35.4
	80	101.3	101.3	108.4	83.4	119.7	60.9	96.9	96.9	103.0	80.8	113.7	58.4	92.2	92.2	97.3	78.1	107.5	55.8	87.3	87.3	91.4	75.3	101.1	53.1
	85	107.3	107.3	109.6	101.4	120.0	78.7	102.8	102.8	104.3	98.8	114.0	76.1	98.0	98.0	98.9	96.2	107.8	73.5	92.9	92.9	92.9	92.9	101.4	70.8
	90	113.4	113.4	113.4	113.4	120.6	96.4	108.8	108.8	108.7	108.7	114.6	93.8	103.8	103.8	103.8	103.8	108.6	91.2	98.6	98.6	98.6	98.6	102.2	88.5
3740	75	99.6	92.9	109.3	68.2	120.7	43.8	94.6	90.3	103.8	65.6	114.8	41.4	89.4	87.6	98.0	62.9	108.5	38.8	83.8	83.8	91.9	60.2	101.9	36.2
	80	104.1	104.1	109.9	87.9	121.0	63.3	99.5	99.5	104.4	85.3	114.9	60.7	94.7	94.7	98.7	82.6	108.7	58.1	89.6	89.6	92.6	79.8	102.1	55.4
	85	110.4	110.4	111.6	107.6	121.4	82.7	105.7	105.7	106.3	105.1	115.3	80.1	100.7	100.7	100.6	100.6	109.0	77.5	95.4	95.4	95.4	95.4	102.5	74.9
	90	116.7	116.7	116.7	116.7	122.1	102.0	111.8	111.8	111.8	111.8	116.2	99.5	106.7	106.7	106.7	106.7	110.0	96.8	101.2	101.2	101.2	101.2	103.6	94.2
4080	75	101.1	97.8	110.5	71.0	121.9	44.6	96.1	95.2	104.9	68.3	115.8	42.1	90.8	90.8	98.9	65.7	109.4	39.5	85.7	85.7	92.7	62.9	102.8	36.8
	80	106.6	106.6	111.2	92.2	122.1	65.7	101.9	101.9	105.7	89.6	116.0	63.1	96.9	96.9	99.8	87.0	109.6	60.5	91.6	91.6	93.8	84.2	103.0	57.8
	85	113.1	113.1	113.0	113.0	122.5	86.7	108.2	108.2	108.1	108.1	116.4	84.1	103.0	103.0	103.0	103.0	110.0	81.5	97.6	97.6	97.6	97.6	103.5	78.8
	90	119.5	119.5	119.5	119.5	123.6	107.6	114.5	114.5	114.5	114.5	117.5	105.0	109.2	109.2	109.2	109.2	111.3	102.4	103.6	103.6	103.6	103.6	104.9	99.8

- Notes:**
- All capacities shown are gross and have not considered indoor fan heat. To obtain **NET** cooling capacity subtract indoor fan heat. For indoor fan heat formula, refer to appropriate airflow table notes.
  - MBH = Total Gross Capacity
  - SHC = Sensible Heat Capacity
- \*For 1700 and 2210 CFM - Unit applications below 320 CFM/Ton are only applicable to T\_C models only (No Gas Heat). See below for restrictions:
- Electric heaters restricted on applications below 320 CFM/Ton.
  - Dehumidification (Hot Gas Reheat) or TXV with Froststat and Crankcase Heaters are required on applications below 320 CFM/Ton.

## Performance Data

*(10 Tons High Efficiency)*

**Table 24. Gross Cooling Capacities 10 Tons Three Phase Standard Refrigeration Option High Efficiency T/YHC120A3,4,W**

		Ambient Temperature																							
		85			95			105			115														
Air Ent Flow DB	CFM (F)	Entering						Wet Bulb																	
		61		67		73		61		67		73		61		67		73							
		MBH	SHC	MBH	SHC	MBH	SHC	MBH	SHC	MBH	SHC	MBH	SHC	MBH	SHC	MBH	SHC	MBH	SHC						
3600	75	107.0	94.4	117.4	75.0	123.4	46.0	98.7	90.1	114.7	68.8	121.9	44.4	88.5	88.5	107.2	65.3	118.6	42.2	82.3	78.8	97.8	61.1	113.6	39.6
	80	110.9	108.6	119.9	88.2	125.0	62.5	104.5	104.1	115.2	87.5	123.4	62.3	97.7	97.7	107.8	84.3	119.4	60.8	90.6	90.6	98.5	80.1	114.3	58.3
	85	117.6	117.6	120.9	105.0	126.6	76.7	113.1	113.1	116.5	105.8	124.9	78.1	106.9	106.9	107.0	107.0	120.9	78.1	99.9	99.9	100.0	100.0	114.8	76.5
	90	122.5	122.5	122.4	122.4	128.2	91.1	119.6	119.6	119.6	117.1	126.4	94.1	115.0	115.0	114.7	114.6	121.6	94.3	109.0	109.0	109.0	109.0	115.8	94.3
4000	75	109.8	100.5	119.4	71.9	122.5	46.5	99.7	99.7	116.1	71.5	121.7	45.0	92.5	92.5	110.1	69.1	119.4	43.0	85.6	83.4	100.9	65.0	114.6	40.5
	80	114.6	114.1	120.8	90.1	124.1	68.3	109.3	109.3	117.0	91.2	123.4	62.7	102.3	102.3	110.8	89.9	120.6	62.5	94.8	94.8	101.9	86.0	115.5	61.1
	85	120.5	120.5	122.3	107.9	125.9	76.4	117.0	117.0	118.6	110.2	125.0	78.8	111.6	111.6	111.8	111.8	122.1	80.4	104.7	104.7	105.8	102.6	116.3	79.7
	90	125.2	125.2	124.2	124.2	127.6	90.9	122.4	122.4	121.7	120.9	126.6	95.1	118.5	118.5	118.3	118.3	123.6	98.4	113.1	113.1	113.3	113.3	117.7	98.6
4400	75	112.3	106.1	121.2	74.8	124.6	47.6	103.6	103.6	117.1	75.5	123.0	46.0	96.7	93.9	111.2	72.2	120.0	43.7	88.6	88.0	102.0	68.2	115.3	41.2
	80	117.6	117.6	122.5	94.7	126.3	64.2	113.0	113.0	118.4	95.8	124.7	64.4	106.3	106.3	112.2	94.9	121.5	64.3	98.8	98.8	103.5	91.1	116.1	62.8
	85	122.4	122.4	124.3	113.8	128.0	79.6	119.6	119.6	119.6	119.6	126.4	81.8	115.1	115.1	115.5	111.7	122.7	83.0	109.1	109.1	108.8	107.4	117.2	83.2
	90	126.0	126.0	127.1	125.0	129.6	95.2	124.3	124.3	124.2	124.2	128.0	99.4	120.9	120.9	120.9	120.9	123.9	101.2	116.1	116.1	116.1	116.1	118.8	103.3
4800	75	113.4	113.4	121.8	76.2	125.0	48.4	107.6	104.0	118.5	77.0	123.5	46.9	99.6	98.2	112.7	75.4	120.5	44.8	91.6	91.6	103.7	71.6	115.9	41.9
	80	119.5	119.5	123.2	97.0	126.7	64.8	115.8	115.8	119.8	99.6	125.2	65.3	109.8	109.8	113.9	99.4	122.1	65.5	102.3	102.3	105.5	96.3	117.2	66.8
	85	124.3	124.3	125.2	116.6	128.4	80.7	121.5	121.5	121.5	121.5	126.9	83.3	117.5	117.5	117.6	115.4	123.7	85.6	111.8	111.8	111.8	111.8	118.5	86.4
	90	127.5	127.5	128.0	126.7	130.1	96.9	126.0	126.0	125.5	125.5	128.6	101.5	122.6	122.6	123.0	123.0	125.5	105.5	118.2	118.2	118.2	118.2	120.3	107.5

**Notes:**

1. All capacities shown are gross and have not considered indoor fan heat. To obtain **NET** cooling capacity subtract indoor fan heat. For indoor fan heat formula, refer to appropriate airflow table notes.
2. MBH = Total Gross Capacity
3. SHC = Sensible Heat Capacity



**Performance Data**

*(10 Tons High Efficiency)*

**Table 25. Gross Cooling Capacities 10 Tons Dehumidification (Hot Gas Reheat) or TXV Option High Efficiency T/YHC120A,3,4,W**

		Ambient Temperature																							
		85						95						105						115					
Air Flow	Ent DB (F)	Entering Wet Bulb																							
		61		67		73		61		67		73		61		67		73		61		67		73	
CFM	(F)	MBH	SHC	MBH	SHC	MBH	SHC	MBH	SHC	MBH	SHC	MBH	SHC	MBH	SHC	MBH	SHC	MBH	SHC	MBH	SHC	MBH	SHC	MBH	SHC
2000*	75	94.2	68.9	105.8	56.2	118.4	42.6	89.7	66.2	101.0	53.6	113.2	40.0	84.8	63.4	95.8	50.9	107.6	37.3	79.7	60.4	90.2	48.1	101.5	34.6
	80	94.4	79.8	106.0	66.8	118.6	53.6	89.9	77.1	101.2	64.1	113.4	51.0	85.0	74.2	96.0	61.4	107.8	48.3	79.9	71.2	90.4	58.4	101.7	45.4
	85	93.0	93.0	106.3	77.6	118.8	64.3	90.4	86.3	101.4	74.9	113.6	61.7	86.1	82.8	96.2	72.1	108.0	59.0	81.6	79.1	90.7	69.2	101.9	56.1
	90	98.0	97.2	106.4	88.3	119.0	75.0	94.4	94.4	101.6	85.6	113.8	72.4	90.4	90.4	96.4	82.8	108.2	69.6	86.1	86.1	90.9	79.8	102.1	66.7
2600*	75	100.5	78.8	112.6	62.6	125.6	44.8	95.6	76.0	107.3	59.9	119.9	42.2	90.4	73.0	101.6	57.1	113.8	39.5	84.8	70.0	95.6	54.1	107.2	36.6
	80	101.1	92.6	112.9	75.8	125.8	58.8	96.4	89.9	107.6	73.1	120.1	56.1	89.7	89.7	101.9	70.2	114.0	53.3	86.0	81.9	95.8	67.1	107.4	50.4
	85	104.0	102.0	113.2	89.6	126.1	72.5	99.7	98.7	107.9	86.8	120.4	69.8	95.4	95.4	102.3	83.9	114.2	67.0	90.6	90.6	96.2	80.9	107.6	64.0
	90	109.9	109.9	113.9	103.3	126.4	86.1	105.6	105.6	108.7	100.5	120.7	83.4	101.1	101.1	101.1	101.1	114.5	80.6	96.2	96.2	97.5	92.3	107.9	77.6
3200	75	104.9	87.8	117.1	67.4	130.2	46.6	99.8	85.0	111.5	65.7	124.2	44.0	94.3	82.0	110.8	64.8	117.7	41.2	88.4	78.9	99.0	59.8	110.7	38.2
	80	106.6	102.0	117.4	84.1	130.5	63.4	102.0	98.4	111.8	81.3	124.5	60.6	97.0	94.6	105.8	78.4	118.0	57.8	91.6	90.5	99.4	75.3	111.0	54.8
	85	112.2	112.2	118.1	100.7	130.8	79.9	107.8	107.8	112.6	98.0	124.7	77.2	103.0	103.0	106.7	95.0	118.2	74.3	97.7	97.7	100.4	91.9	111.2	71.3
	90	118.6	118.6	118.8	118.8	131.1	96.5	114.2	114.2	115.0	110.5	125.1	93.7	109.2	109.2	109.6	106.5	118.7	90.8	103.8	103.8	103.9	102.2	111.7	87.8
3600	75	107.3	93.6	119.4	70.7	132.5	47.7	102.1	90.8	113.6	67.9	126.3	45.0	96.5	87.8	107.2	64.9	119.4	42.1	90.4	84.7	100.6	61.8	112.1	39.1
	80	110.3	107.5	119.7	89.4	132.8	66.3	105.6	104.0	114.0	86.6	126.6	63.5	100.4	100.3	107.6	83.5	119.6	60.5	95.1	95.1	101.1	80.4	112.4	57.5
	85	116.7	116.7	120.8	107.9	133.2	84.7	112.2	112.2	115.2	105.1	126.9	82.0	107.1	107.1	108.9	102.1	119.9	79.0	101.4	101.4	101.4	101.4	112.7	75.9
	90	123.5	123.5	124.2	120.7	133.7	103.1	118.8	118.8	119.0	116.9	127.5	100.3	113.6	113.6	113.2	112.8	120.6	97.3	107.7	107.7	107.7	107.7	113.4	94.2
4000	75	110.8	101.0	122.7	75.2	136.1	49.4	105.2	97.9	116.6	72.2	129.5	46.5	99.5	94.8	110.2	69.2	122.6	43.6	92.8	92.8	103.6	66.0	115.5	40.6
	80	115.3	115.3	123.1	96.0	136.3	70.2	110.3	110.3	117.0	93.1	129.7	67.3	105.0	105.0	110.7	90.0	122.9	64.3	99.5	99.5	104.1	86.8	115.7	61.3
	85	122.3	122.3	124.5	116.8	136.6	90.7	117.2	117.2	117.2	117.2	130.0	87.8	111.8	111.8	111.8	111.8	123.1	84.8	106.2	106.2	106.6	103.4	116.0	81.8
	90	129.5	129.5	129.3	129.3	137.2	111.3	124.2	124.2	124.2	124.2	130.6	108.4	118.7	118.7	118.6	118.6	123.9	105.4	112.9	112.9	112.8	112.8	116.9	102.4
4400	75	112.7	106.4	124.3	78.3	137.7	50.3	106.1	106.1	118.0	75.3	130.9	47.4	100.8	100.8	111.5	72.2	123.9	44.4	95.5	93.3	104.7	69.1	116.7	41.4
	80	118.4	118.4	124.8	100.9	137.9	72.8	113.2	113.2	118.6	98.0	131.2	69.9	107.8	107.8	112.2	94.9	124.2	67.0	102.1	102.1	105.5	91.7	116.9	63.9
	85	125.7	125.7	125.7	125.7	138.2	95.2	120.4	120.4	120.4	120.4	131.5	92.3	114.8	114.8	115.1	112.5	124.5	89.3	109.0	109.0	109.0	107.8	117.3	86.3
	90	133.1	133.1	133.1	133.1	139.0	117.5	127.6	127.6	127.6	127.6	132.4	114.6	121.9	121.9	121.9	121.9	125.5	111.6	115.9	115.9	115.9	115.9	118.5	108.6
4800	75	113.7	113.7	125.6	81.3	139.0	51.1	108.5	108.5	119.2	78.3	132.2	48.2	103.0	103.0	112.6	75.2	125.1	45.3	97.3	96.6	105.8	72.0	117.7	42.2
	80	121.1	121.1	126.2	105.7	139.3	75.4	115.8	115.8	120.0	102.7	132.4	72.5	110.2	110.2	113.5	99.7	125.3	69.5	104.4	104.4	106.8	96.5	118.0	66.5
	85	128.6	128.6	128.6	128.6	139.6	99.5	123.2	123.2	123.4	121.4	132.8	96.6	117.4	117.4	117.4	116.7	125.7	93.6	111.5	111.5	111.4	111.4	118.4	90.6
	90	136.2	136.2	136.2	136.2	140.7	123.6	130.6	130.6	130.6	130.6	134.0	120.7	124.7	124.7	124.7	124.7	127.1	117.6	118.5	118.5	118.5	118.5	118.5	118.5

**Notes:**

- All capacities shown are gross and have not considered indoor fan heat. To obtain **NET** cooling capacity subtract indoor fan heat. For indoor fan heat formula, refer to appropriate airflow table notes.
  - MBH = Total Gross Capacity
  - SHC = Sensible Heat Capacity
- \*For 2000 and 2600 CFM - Unit applications below 320 CFM/Ton are only applicable to T\_C models only (No Gas Heat). See below for restrictions:
- Electric heaters restricted on applications below 320 CFM/Ton.
  - Dehumidification (Hot Gas Reheat) or TXV with Froststat and Crankcase Heaters are required on applications below 320 CFM/Ton.

# Performance Data

**Table 26. Direct Drive Evaporator Fan Performance 3-5 Tons with Optional Electric Heat TSC036A, TSC048A, TSC060A**

		External Static Pressure (Inches of Water) & Motor Power (Bhp) <sup>(i)</sup>									
		Standard Motor						Oversized Motor <sup>(ii)</sup>			
Tons	Unit Model Number	CFM	High Speed		Low Speed		High Speed		Low Speed		
			ESP	BHP	ESP	BHP	ESP	BHP	ESP	BHP	
3	TSC036A	960	0.86	0.36	0.61	0.28	1.01	0.39	0.89	0.35	
	Downflow	1020	0.82	0.37	0.62	0.28	0.99	0.41	0.91	0.47	
	Airflow	1080	0.78	0.38	0.55	0.29	0.96	0.43	0.87	0.39	
		1140	0.74	0.39	0.47	0.29	0.93	0.44	0.82	0.40	
		1200	0.71	0.40	0.39	0.30	0.89	0.45	0.79	0.41	
		1260	0.65	0.41	0.31	0.30	0.85	0.46	0.75	0.42	
		1320	0.60	0.42	0.19	0.31	0.80	0.48	0.70	0.44	
		1380	0.54	0.42	0.10	0.31	0.75	0.49	0.64	0.45	
		1440	0.49	0.43	—	—	0.69	0.52	0.59	0.48	
4	TSC048A	1280	0.98	0.53	0.86	0.47	1.25	0.67	1.04	0.56	
	Downflow	1360	0.92	0.54	0.80	0.47	1.20	0.68	0.99	0.58	
	Airflow	1440	0.85	0.54	0.73	0.48	1.15	0.70	0.93	0.60	
		1520	0.78	0.55	0.65	0.48	1.10	0.73	0.86	0.63	
		1600	0.71	0.55	0.56	0.49	1.05	0.75	0.79	0.64	
		1680	0.62	0.56	0.43	0.49	1.00	0.78	0.70	0.66	
		1760	0.52	0.56	0.28	0.50	0.95	0.82	0.55	0.68	
		1840	0.42	0.57	0.18	0.50	0.88	0.83	0.40	0.70	
		1920	0.32	0.57	—	—	0.80	0.85	—	—	
5	TSC060A3 <sup>(iii)</sup>	1600	0.95	0.78	0.87	0.64	1.25	0.90	1.10	0.85	
	Downflow	1700	0.90	0.82	0.73	0.65	1.20	0.94	1.00	0.89	
	Airflow	1800	0.85	0.85	0.61	0.65	1.10	0.98	0.90	0.91	
		1900	0.75	0.88	0.51	0.65	1.03	1.02	0.80	0.94	
		2000	0.65	0.90	0.35	0.66	0.95	1.05	0.70	0.95	
		2100	0.55	0.93	0.19	0.66	0.85	1.10	0.55	0.96	
		2200	0.45	0.95	0.10	0.67	0.75	1.12	0.40	0.96	
		2300	0.35	0.97	—	—	0.65	1.17	0.20	0.97	
		2400	0.25	1.00	—	—	0.53	1.20	—	—	
3	TSC036A	960	0.81	0.36	0.61	0.28	0.96	0.39	0.89	0.35	
	Horizontal	1020	0.77	0.37	0.57	0.28	0.94	0.41	0.86	0.47	
	Airflow	1080	0.73	0.38	0.50	0.29	0.91	0.43	0.82	0.39	
		1140	0.69	0.39	0.42	0.29	0.88	0.44	0.77	0.40	
		1200	0.66	0.40	0.34	0.30	0.84	0.45	0.74	0.41	
		1260	0.60	0.41	0.26	0.30	0.80	0.46	0.70	0.42	
		1320	0.55	0.42	0.14	0.31	0.75	0.48	0.65	0.44	
		1380	0.49	0.42	0.05	0.31	0.70	0.49	0.59	0.45	
		1440	0.44	0.43	—	—	0.64	0.52	0.54	0.48	
4	TSC048A	1280	0.93	0.53	0.81	0.47	1.20	0.67	0.99	0.56	
	Horizontal	1360	0.87	0.54	0.75	0.47	1.15	0.68	0.94	0.58	
	Airflow	1440	0.80	0.54	0.68	0.48	1.10	0.70	0.88	0.60	
		1520	0.73	0.55	0.60	0.48	1.05	0.73	0.81	0.63	
		1600	0.66	0.55	0.51	0.49	1.00	0.75	0.74	0.64	
		1680	0.57	0.56	0.38	0.49	0.95	0.78	0.65	0.66	
		1760	0.47	0.56	0.23	0.50	0.90	0.82	0.50	0.68	
		1840	0.37	0.57	0.13	0.50	0.83	0.83	0.35	0.70	
		1920	0.27	0.57	—	—	0.75	0.85	0.25	0.73	
5	TSC060A	1600	0.90	0.78	0.82	0.64	1.20	0.90	1.05	0.85	
	Horizontal	1700	0.85	0.82	0.68	0.65	1.15	0.94	0.95	0.89	
	Airflow	1800	0.80	0.85	0.56	0.65	1.05	0.98	0.85	0.91	
		1900	0.70	0.88	0.46	0.65	0.98	1.02	0.75	0.94	
		2000	0.60	0.90	0.30	0.66	0.90	1.05	0.65	0.95	
		2100	0.50	0.93	0.14	0.66	0.80	1.10	0.50	0.96	
		2200	0.40	0.95	0.05	0.67	0.70	1.12	0.35	0.96	
		2300	0.30	0.97	—	—	0.60	1.17	0.15	0.97	
		2400	0.20	1.00	—	—	0.48	1.20	—	—	

**Notes:**

1. Fan motor heat (MBH) = 3.72 x Fan Bhp + .24. Factory supplied motors, in commercial equipment, are definite purpose motors, specifically designed and tested to operate reliably and continuously at all cataloged conditions. Using the full horsepower range of our fan motors as shown in our tabular data will not result in nuisance tripping or premature motor failure. Our product's warranty will not be affected.

<sup>(i)</sup> Data includes pressure drop due to wet coil and filters.

<sup>(ii)</sup> 5 ton oversized motor performance is with 12 x 11 FC blower wheel.

<sup>(iii)</sup> TSC060AK\* (downflow and horizontal) uses a 1.0 hp direct drive motor and 12x11 FC centrifugal blower wheel. Refer to oversized motor column for the standard motor performance data.

## Performance Data

*(Standard Efficiency)*

**Table 27. Direct Drive Evaporator Fan Performance 3-5 Tons with Gas Heat YSC036A, YSC048A, YSC060A Low and Medium Heat**

			External Static Pressure (Inches of Water) & Motor Power (Bhp) <sup>(i)</sup>							
			Standard Motor				Oversized Motor <sup>(ii)</sup>			
Tons	Unit Model Number	CFM	High Speed		Low Speed		High Speed		Low Speed	
			ESP	BHP	ESP	BHP	ESP	BHP	ESP	BHP
3	YSC036A**L,M	960	0.81	0.36	0.61	0.28	0.96	0.39	0.89	0.35
	Downflow	1020	0.77	0.37	0.57	0.28	0.94	0.41	0.86	0.47
	Airflow	1080	0.73	0.38	0.50	0.29	0.91	0.43	0.82	0.39
		1140	0.69	0.39	0.42	0.29	0.88	0.44	0.77	0.40
		1200	0.66	0.40	0.34	0.30	0.84	0.45	0.74	0.41
		1260	0.60	0.41	0.26	0.30	0.80	0.46	0.70	0.42
		1320	0.55	0.42	0.14	0.31	0.75	0.48	0.65	0.44
		1380	0.49	0.42	0.05	0.31	0.70	0.49	0.59	0.45
	1440	0.44	0.43	—	—	0.64	0.52	0.54	0.48	
4	YSC048A**L,M	1280	0.93	0.53	0.81	0.47	1.20	0.67	0.99	0.56
	Downflow	1360	0.87	0.54	0.75	0.47	1.15	0.68	0.94	0.58
	Airflow	1440	0.80	0.54	0.68	0.48	1.10	0.70	0.88	0.60
		1520	0.73	0.55	0.60	0.48	1.05	0.73	0.81	0.63
		1600	0.66	0.55	0.51	0.49	1.00	0.75	0.74	0.64
		1680	0.57	0.56	0.38	0.49	0.95	0.78	0.65	0.66
		1760	0.47	0.56	0.23	0.50	0.90	0.82	0.50	0.68
		1840	0.37	0.57	0.13	0.50	0.83	0.83	0.35	0.70
	1920	0.27	0.57	—	—	0.75	0.85	—	—	
5	YSC060A**L,M <sup>(iii)</sup>	1600	0.90	0.78	0.82	0.64	1.20	0.90	1.05	0.85
	Downflow	1700	0.85	0.82	0.68	0.65	1.15	0.94	0.95	0.89
	Airflow	1800	0.80	0.85	0.56	0.65	1.05	0.98	0.85	0.91
		1900	0.70	0.88	0.46	0.65	0.98	1.02	0.75	0.94
		2000	0.60	0.90	0.30	0.66	0.90	1.05	0.65	0.95
		2100	0.50	0.93	0.14	0.66	0.80	1.10	0.50	0.96
		2200	0.40	0.95	0.05	0.67	0.70	1.12	0.35	0.96
		2300	0.30	0.97	—	—	0.60	1.17	0.15	0.97
	2400	0.20	1.00	—	—	0.48	1.20	—	—	
3	YSC036A**L,M	960	0.81	0.36	0.61	0.28	0.96	0.39	0.89	0.35
	Horizontal	1020	0.77	0.37	0.57	0.28	0.94	0.41	0.86	0.47
	Airflow	1080	0.73	0.38	0.50	0.29	0.91	0.43	0.82	0.39
		1140	0.69	0.39	0.42	0.29	0.88	0.44	0.77	0.40
		1200	0.66	0.40	0.34	0.30	0.84	0.45	0.74	0.41
		1260	0.60	0.41	0.26	0.30	0.80	0.46	0.70	0.42
		1320	0.55	0.42	0.14	0.31	0.75	0.48	0.65	0.44
		1380	0.49	0.42	0.05	0.31	0.70	0.49	0.59	0.45
	1440	0.44	0.43	—	—	0.64	0.52	0.54	0.48	
4	YSC048A**L,M	1280	0.88	0.53	0.76	0.47	1.15	0.67	0.94	0.56
	Horizontal	1360	0.82	0.54	0.70	0.47	1.10	0.68	0.89	0.58
	Airflow	1440	0.75	0.54	0.63	0.48	1.05	0.70	0.83	0.60
		1520	0.68	0.55	0.55	0.48	1.00	0.73	0.76	0.63
		1600	0.61	0.55	0.46	0.49	0.95	0.75	0.69	0.64
		1680	0.52	0.56	0.33	0.49	0.90	0.78	0.60	0.66
		1760	0.42	0.56	0.18	0.50	0.85	0.82	0.45	0.68
		1840	0.32	0.57	0.08	0.50	0.78	0.83	0.30	0.70
	1920	0.22	0.57	—	—	0.70	0.85	0.20	0.73	
5	YSC060A**L,M	1600	0.85	0.78	0.77	0.64	1.15	0.90	1.00	0.85
	Horizontal	1700	0.80	0.82	0.63	0.65	1.10	0.94	0.90	0.89
	Airflow	1800	0.75	0.85	0.51	0.65	1.00	0.98	0.80	0.91
		1900	0.65	0.88	0.41	0.65	0.93	1.02	0.70	0.94
		2000	0.55	0.90	0.25	0.66	0.85	1.05	0.60	0.95
		2100	0.45	0.93	0.09	0.66	0.75	1.10	0.45	0.96
		2200	0.35	0.95	0.00	0.67	0.65	1.12	0.30	0.96
		2300	0.25	0.97	—	—	0.55	1.17	0.10	0.97
	2400	0.15	1.00	—	—	0.43	1.20	—	—	

**Notes:**

1. Fan motor heat (MBH) = 3.72 x Fan Bhp + .24. Factory supplied motors, in commercial equipment, are definite purpose motors, specifically designed and tested to operate reliably and continuously at all cataloged conditions. Using the full horsepower range of our fan motors as shown in our tabular data will not result in nuisance tripping or premature motor failure. Our product's warranty will not be affected.

<sup>(i)</sup> Data includes pressure drop due to wet coil and filters.

<sup>(ii)</sup> 5 ton oversized motor performance is with 12 x 11 FC blower wheel.

<sup>(iii)</sup> YSC060AK\* (downflow and horizontal) uses a 1.0 hp direct drive motor and 12x11 FC Centrifugal blower wheel. Refer to oversized motor column for the standard motor performance data.

## Performance Data

*(Standard Efficiency)*

**Table 28. Direct Drive Evaporator Fan Performance 3-5 Tons with Gas Heat YSC036A, YSC048A, YSC060A High Heat**

		External Static Pressure (Inches of Water) & Motor Power (Bhp) <sup>(i)</sup>								
		Standard Motor				Oversized Motor <sup>(ii)</sup>				
Tons	Unit Model Number	CFM	High Speed		Low Speed		High Speed		Low Speed	
			ESP	BHP	ESP	BHP	ESP	BHP	ESP	BHP
3	YSC036A**H	960	0.76	0.36	0.56	0.28	0.91	0.39	0.84	0.35
	Downflow	1020	0.72	0.37	0.52	0.28	0.89	0.41	0.81	0.47
	Airflow	1080	0.68	0.38	0.45	0.29	0.86	0.43	0.77	0.39
		1140	0.64	0.39	0.37	0.29	0.83	0.44	0.72	0.40
		1200	0.61	0.40	0.29	0.30	0.79	0.45	0.69	0.41
		1260	0.55	0.41	0.21	0.30	0.75	0.46	0.65	0.42
		1320	0.50	0.42	0.09	0.31	0.70	0.48	0.60	0.44
		1380	0.44	0.42	0.00	0.31	0.65	0.49	0.54	0.45
		1440	0.39	0.43	—	—	0.59	0.52	0.49	0.48
4	YSC048A**H	1280	0.93	0.53	0.81	0.47	1.20	0.67	0.99	0.56
	Downflow	1360	0.87	0.54	0.75	0.47	1.15	0.68	0.94	0.58
	Airflow	1440	0.80	0.54	0.68	0.48	1.10	0.70	0.88	0.60
		1520	0.73	0.55	0.60	0.48	1.05	0.73	0.81	0.63
		1600	0.66	0.55	0.51	0.49	1.00	0.75	0.74	0.64
		1680	0.57	0.56	0.38	0.49	0.95	0.78	0.65	0.66
		1760	0.47	0.56	0.23	0.50	0.90	0.82	0.50	0.68
		1840	0.37	0.57	0.13	0.50	0.83	0.83	0.35	0.70
		1920	0.27	0.57	—	—	0.75	0.85	—	—
5	YSC060A**H <sup>(iii)</sup>	1600	0.90	0.78	0.82	0.64	1.20	0.90	1.05	0.85
	Downflow	1700	0.85	0.82	0.68	0.65	1.15	0.94	0.95	0.89
	Airflow	1800	0.80	0.85	0.56	0.65	1.05	0.98	0.85	0.91
		1900	0.70	0.88	0.46	0.65	0.98	1.02	0.75	0.94
		2000	0.60	0.90	0.30	0.66	0.90	1.05	0.65	0.95
		2100	0.50	0.93	0.14	0.66	0.80	1.10	0.50	0.96
		2200	0.40	0.95	0.00	0.67	0.70	1.12	0.35	0.96
		2300	0.30	0.97	—	—	0.60	1.17	0.15	0.97
		2400	0.20	1.00	—	—	0.48	1.20	—	—
3	YSC036A**H	960	0.76	0.36	0.56	0.28	0.91	0.39	0.84	0.35
	Horizontal	1020	0.72	0.37	0.52	0.28	0.89	0.41	0.81	0.47
	Airflow	1080	0.68	0.38	0.45	0.29	0.86	0.43	0.77	0.39
		1140	0.64	0.39	0.37	0.29	0.83	0.44	0.72	0.40
		1200	0.61	0.40	0.29	0.30	0.79	0.45	0.69	0.41
		1260	0.55	0.41	0.21	0.30	0.75	0.46	0.65	0.42
		1320	0.50	0.42	0.09	0.31	0.70	0.48	0.60	0.44
		1380	0.44	0.42	0.00	0.31	0.65	0.49	0.54	0.45
		1440	0.39	0.43	—	—	0.59	0.52	0.49	0.48
4	YSC048A**H	1280	0.88	0.53	0.76	0.47	1.15	0.67	0.94	0.56
	Horizontal	1360	0.82	0.54	0.70	0.47	1.10	0.68	0.89	0.58
	Airflow	1440	0.75	0.54	0.63	0.48	1.05	0.70	0.83	0.60
		1520	0.68	0.55	0.55	0.48	1.00	0.73	0.76	0.63
		1600	0.61	0.55	0.46	0.49	0.95	0.75	0.69	0.64
		1680	0.52	0.56	0.33	0.49	0.90	0.78	0.60	0.66
		1760	0.42	0.56	0.18	0.50	0.85	0.82	0.45	0.68
		1840	0.32	0.57	0.08	0.50	0.78	0.83	0.30	0.70
		1920	0.22	0.57	—	—	0.70	0.85	0.20	0.73
5	YSC060A**H	1600	0.85	0.78	0.77	0.64	1.15	0.90	1.00	0.85
	Horizontal	1700	0.80	0.82	0.63	0.65	1.10	0.94	0.90	0.89
	Airflow	1800	0.75	0.85	0.51	0.65	1.00	0.98	0.80	0.91
		1900	0.65	0.88	0.41	0.65	0.93	1.02	0.70	0.94
		2000	0.55	0.90	0.25	0.66	0.85	1.05	0.60	0.95
		2100	0.45	0.93	0.09	0.66	0.75	1.10	0.45	0.96
		2200	0.35	0.95	0.00	0.67	0.65	1.12	0.30	0.96
		2300	0.25	0.97	—	—	0.55	1.17	0.10	0.97
		2400	0.15	1.00	—	—	0.43	1.20	—	—

**Notes:**

- Fan motor heat (MBH) = 3.72 x Fan Bhp + .24.
- Factory supplied motors, in commercial equipment, are definite purpose motors, specifically designed and tested to operate reliably and continuously at all cataloged conditions. Using the full horsepower range of our fan motors as shown in our tabular data will not result in nuisance tripping or premature motor failure. Our product's warranty will not be affected.

<sup>(i)</sup> Data includes pressure drop due to wet coil and filters.

<sup>(ii)</sup> 5 ton oversized motor performance is with 12 x 11 FC blower wheel.

<sup>(iii)</sup> YSC060AK\* (downflow and horizontal) uses a 1.0 hp direct drive motor and 12x11 FC Centrifugal blower wheel. Refer to oversized motor column for the standard motor performance data.

# Performance Data

**Table 29. Belt Drive Evaporator Fan Performance 3 Tons with Electric Heat TSC036A3,4,W Downflow Airflow**

External Static Pressure (Inches of Water)																					
		.10		.20		.30		.40		.50		.60		.70		.80		.90		1.00	
CFM	RPM	BHP	RPM	BHP	RPM	BHP	RPM	BHP	RPM	BHP	RPM	BHP	RPM	BHP	RPM	BHP	RPM	BHP	RPM	BHP	
<b>1-HP Standard Motor &amp; Field Supplied Low Static Drive<sup>(i)</sup></b>											<b>1-HP Standard Motor Drive</b>										
960	—	—	528	0.12	599	0.16	658	0.20	713	0.24	763	0.29	810	0.33	855	0.38	898	0.43	939	0.49	
1080	—	—	557	0.15	625	0.19	685	0.24	738	0.28	786	0.33	832	0.38	876	0.43	917	0.48	957	0.54	
1200	—	—	588	0.19	652	0.23	712	0.28	764	0.33	811	0.38	856	0.43	898	0.48	939	0.54	978	0.59	
1320	552	0.18	622	0.23	681	0.27	738	0.32	790	0.38	838	0.44	882	0.49	923	0.55	962	0.60	1000	0.66	
1440	588	0.23	657	0.28	713	0.33	765	0.37	817	0.43	865	0.50	909	0.56	949	0.62	987	0.68	1024	0.74	

**Continued**

External Static Pressure (Inches of Water)											
		1.10		1.20		1.30		1.40		1.50	
CFM	RPM	BHP	RPM	BHP	RPM	BHP	RPM	BHP	RPM	BHP	
<b>1-HP Standard Motor &amp; Drive</b>											
960	978	0.54	1016	0.60	1052	0.66	1086	0.72	1120	0.78	
1080	995	0.59	1033	0.65	1069	0.71	1103	0.78	1136	0.84	
1200	1015	0.65	1051	0.71	1086	0.77	1120	0.84	1154	0.91	
1320	1036	0.72	1072	0.78	1106	0.85	1138	0.91	1171	0.98	
1440	1060	0.80	1094	0.86	1128	0.93	1160	1.00	1192	1.07	
<b>1-HP Standard Motor &amp; Field Supplied High Static Drive<sup>(ii)</sup></b>											

For Standard Evaporator Fan Speed (RPM), reference [Table 123](#).  
 Notes:  
 Data includes pressure drop due to standard filters and wet coils.  
 No accessories or options are included in pressure drop data.  
 Refer to [Table 128](#) to determine additional static pressure drop due to other options/accessories.  
 Fan Motor Heat (MBH) = 2.829 x Fan BHP+.4024.  
 Factory supplied motors, in commercial equipment, are definite purpose motors, specifically designed and tested to operate reliably and continuously at all cataloged conditions. Using the full horsepower range of our fan motors as shown in our tabular data will not result in nuisance tripping or premature motor failure. Our product's warranty will not be affected.

<sup>(i)</sup> Field Supplied Fan Sheave AK69 required. Field Supplied Belt may be necessary.  
<sup>(ii)</sup> Field Supplied Fan Sheave AK41 required. Field Supplied Belt may be necessary.

**Table 30. Belt Drive Evaporator Fan Performance 3 Tons with Electric Heat TSC036A3,4,W Horizontal Airflow**

External Static Pressure (Inches of Water)																					
		.10		.20		.30		.40		.50		.60		.70		.80		.90		1.00	
CFM	RPM	BHP	RPM	BHP	RPM	BHP	RPM	BHP	RPM	BHP	RPM	BHP	RPM	BHP	RPM	BHP	RPM	BHP	RPM	BHP	
<b>1-HP Standard Motor &amp; Field Supplied Low Static Drive<sup>(i)</sup></b>											<b>1-HP Standard Motor Drive</b>										
960	—	—	588	0.15	661	0.19	725	0.24	782	0.29	832	0.35	878	0.40	919	0.46	958	0.51	996	0.56	
1080	531	0.13	622	0.18	694	0.24	756	0.29	813	0.34	864	0.40	910	0.46	954	0.52	993	0.59	1031	0.65	
1200	570	0.17	654	0.23	727	0.28	787	0.34	843	0.40	895	0.46	942	0.52	986	0.59	1026	0.66	1064	0.73	
1320	610	0.22	687	0.28	760	0.34	821	0.40	875	0.46	925	0.53	973	0.59	1017	0.66	1058	0.73	1095	0.81	
1440	651	0.27	723	0.33	793	0.40	855	0.47	908	0.53	956	0.60	1003	0.67	1047	0.75	1088	0.82	1127	0.89	
<b>1-HP Standard Motor &amp; Field Supplied High Static Drive<sup>(ii)</sup></b>																					

**Continued**

External Static Pressure (Inches of Water)											
		1.10		1.20		1.30		1.40		1.50	
CFM	RPM	BHP	RPM	BHP	RPM	BHP	RPM	BHP	RPM	BHP	
<b>1-HP Standard Motor &amp; Drive</b>											
960	1032	0.62	1066	0.67	1101	0.73	1133	0.79	1166	0.86	
1080	1065	0.70	1099	0.76	1132	0.82	1164	0.89	1194	0.95	
1200	1099	0.80	1133	0.86	1166	0.93	1197	0.99	1227	1.06	
1320	1132	0.88	1167	0.96	1200	1.04	1230	1.11	1261	1.19	
1440	1164	0.97	1199	1.05	1232	1.14	1263	1.22	1294	1.30	
<b>1-HP Standard Motor &amp; Field Supplied High Static Drive<sup>(iii)</sup></b>											

For Standard Evaporator Fan Speed (RPM), reference [Table 123](#).  
 Notes:  
 Data includes pressure drop due to standard filters and wet coils.  
 No accessories or options are included in pressure drop data.  
 Refer to [Table 128](#) to determine additional static pressure drop due to other options/accessories.  
 Fan Motor Heat (MBH) = 2.829 x Fan BHP+.4024.  
 Factory supplied motors, in commercial equipment, are definite purpose motors, specifically designed and tested to operate reliably and continuously at all cataloged conditions. Using the full horsepower range of our fan motors as shown in our tabular data will not result in nuisance tripping or premature motor failure. Our product's warranty will not be affected.

<sup>(i)</sup> Field Supplied Fan Sheave AK69 required. Field Supplied Belt may be necessary.  
<sup>(ii)</sup> Field Supplied Fan Sheave AK41 required. Field Supplied Belt may be necessary.  
<sup>(iii)</sup> Field Supplied Fan Sheave AK41 required. Field Supplied Belt may be necessary.

## Performance Data

*(3 Tons Standard Efficiency)*

**Table 31. Belt Drive Evaporator Fan Performance 3 Tons with Gas Heat YSC036A3,4,W\*L,M Low & Medium Heat Downflow Airflow**

External Static Pressure (Inches of Water)																					
		.10		.20		.30		.40		.50		.60		.70		.80		.90		1.00	
CFM	RPM	BHP	RPM	BHP	RPM	BHP	RPM	BHP	RPM	BHP	RPM	BHP	RPM	BHP	RPM	BHP	RPM	BHP	RPM	BHP	
<b>1-HP Standard Motor &amp; Field Supplied Low Static Drive<sup>(i)</sup></b>										<b>1-HP Standard Motor Drive</b>											
960	—	—	570	0.14	634	0.18	690	0.22	741	0.27	791	0.31	836	0.36	879	0.41	922	0.46	961	0.52	
1080	537	0.14	606	0.18	669	0.23	724	0.27	773	0.32	819	0.36	864	0.41	906	0.47	946	0.52	985	0.58	
1200	581	0.18	645	0.22	705	0.27	759	0.33	807	0.38	851	0.42	894	0.48	935	0.53	973	0.59	1011	0.65	
1320	627	0.23	686	0.28	742	0.33	795	0.39	842	0.44	885	0.50	927	0.55	966	0.61	1003	0.67	1040	0.73	
1440	673	0.29	728	0.34	780	0.39	831	0.45	878	0.52	921	0.58	960	0.64	998	0.69	1034	0.76	1070	0.82	
<b>Continued</b>																					
External Static Pressure (Inches of Water)																					
		1.10		1.20		1.30		1.40		1.50											
CFM	RPM	BHP	RPM	BHP	RPM	BHP	RPM	BHP	RPM	BHP											
<b>1-HP Standard Motor &amp; Drive</b>																					
960	1000	0.57	1037	0.63	1072	0.69	1106	0.75	1139	0.81											
1080	1022	0.64	1058	0.70	1093	0.76	1127	0.82	1161	0.89											
1200	1047	0.71	1083	0.77	1117	0.83	1150	0.90	1183	0.97											
1320	1075	0.79	1108	0.85	1141	0.92	1174	0.99	1206	1.06											
1440	1104	0.88	1137	0.95	1170	1.02	1201	1.09	1231	1.16											
<b>1-HP Standard Motor &amp; Field Supplied High Static Drive<sup>(ii)</sup></b>																					

For Standard Evaporator Fan Speed (RPM), reference [Table 123](#).  
Notes:  
Data includes pressure drop due to standard filters and wet coils. No accessories or options are included in pressure drop data. Refer to [Table 128](#) to determine additional static pressure drop due to other options/accessories.  
Fan Motor Heat (MBH) = 2.829 x Fan BHP+.4024.  
Factory supplied motors, in commercial equipment, are definite purpose motors, specifically designed and tested to operate reliably and continuously at all cataloged conditions. Using the full horsepower range of our fan motors as shown in our tabular data will not result in nuisance tripping or premature motor failure. Our product's warranty will not be affected.

<sup>(i)</sup> Field Supplied Fan Sheave AK69 required. Field Supplied Belt may be necessary.  
<sup>(ii)</sup> Field Supplied Fan Sheave AK41 required. Field Supplied Belt may be necessary.

**Table 32. Belt Drive Evaporator Fan Performance 3 Tons with Gas Heat YSC036A3,4,W\*H High Heat Downflow Airflow**

External Static Pressure (Inches of Water)																					
		.10		.20		.30		.40		.50		.60		.70		.80		.90		1.00	
CFM	RPM	BHP	RPM	BHP	RPM	BHP	RPM	BHP	RPM	BHP	RPM	BHP	RPM	BHP	RPM	BHP	RPM	BHP	RPM	BHP	
<b>1-HP Standard Motor &amp; Field Supplied Low Static Drive<sup>(i)</sup></b>										<b>1-HP Standard Motor Drive</b>											
960	503	0.11	578	0.15	641	0.19	696	0.23	747	0.27	796	0.32	841	0.36	884	0.42	926	0.47	966	0.52	
1080	548	0.15	616	0.19	678	0.23	731	0.28	780	0.32	826	0.37	870	0.42	912	0.47	952	0.53	991	0.59	
1200	593	0.19	657	0.23	716	0.28	768	0.33	815	0.38	859	0.43	901	0.49	942	0.54	980	0.60	1017	0.66	
1320	640	0.24	698	0.29	754	0.34	806	0.40	852	0.45	895	0.51	935	0.56	974	0.62	1012	0.68	1048	0.74	
1440	688	0.31	742	0.35	794	0.41	844	0.47	890	0.53	931	0.59	970	0.65	1009	0.71	1045	0.77	1080	0.84	
<b>Continued</b>																					
External Static Pressure (Inches of Water)																					
		1.10		1.20		1.30		1.40		1.50											
CFM	RPM	BHP	RPM	BHP	RPM	BHP	RPM	BHP	RPM	BHP											
<b>1-HP Standard Motor &amp; Drive</b>																					
960	1005	0.58	1041	0.64	1076	0.70	1110	0.76	1142	0.82											
1080	1029	0.65	1064	0.71	1099	0.77	1133	0.83	1166	0.90											
1200	1053	0.72	1089	0.78	1123	0.85	1156	0.91	1189	0.98											
1320	1082	0.80	1116	0.87	1150	0.93	1182	1.00	1214	1.07											
1440	1113	0.90	1146	0.97	1178	1.04	1209	1.11	1240	1.18											
<b>1-HP Standard Motor &amp; Field Supplied High Static Drive<sup>(ii)</sup></b>																					

For Standard Evaporator Fan Speed (RPM), reference [Table 123](#).  
Notes:  
Data includes pressure drop due to standard filters and wet coils. No accessories or options are included in pressure drop data. Refer to [Table 128](#) to determine additional static pressure drop due to other options/accessories.  
Fan Motor Heat (MBH) = 2.829 x Fan BHP+.4024.  
Factory supplied motors, in commercial equipment, are definite purpose motors, specifically designed and tested to operate reliably and continuously at all cataloged conditions. Using the full horsepower range of our fan motors as shown in our tabular data will not result in nuisance tripping or premature motor failure. Our product's warranty will not be affected.

<sup>(i)</sup> Field Supplied Fan Sheave AK69 required. Field Supplied Belt may be necessary.  
<sup>(ii)</sup> Field Supplied Fan Sheave AK41 required. Field Supplied Belt may be necessary.

**Performance Data**

*(3 Tons Standard Efficiency)*

**Table 33. Belt Drive Evaporator Fan Performance 3 Tons with Gas Heat YSC036A3,4,W\*L,M Low & Medium Heat Horizontal Airflow**

External Static Pressure (Inches of Water)																					
		.10		.20		.30		.40		.50		.60		.70		.80		.90		1.00	
CFM	RPM	BHP	RPM	BHP	RPM	BHP	RPM	BHP	RPM	BHP	RPM	BHP	RPM	BHP	RPM	BHP	RPM	BHP	RPM	BHP	
<b>1-HP Standard Motor &amp; Field Supplied Low Static Drive<sup>(i)</sup></b>										<b>1-HP Standard Motor Drive</b>											
960	552	0.13	631	0.17	699	0.22	759	0.27	811	0.33	858	0.38	902	0.44	943	0.49	980	0.54	1017	0.60	
1080	598	0.17	675	0.22	739	0.27	798	0.33	850	0.38	898	0.44	941	0.50	982	0.57	1020	0.63	1056	0.69	
1200	645	0.22	720	0.28	781	0.33	837	0.39	889	0.45	937	0.51	981	0.58	1021	0.65	1059	0.72	1095	0.79	
1320	693	0.28	766	0.34	825	0.40	879	0.47	929	0.53	976	0.60	1020	0.67	1061	0.74	1099	0.81	1135	0.89	
1440	743	0.35	811	0.42	871	0.49	922	0.55	970	0.62	1016	0.69	1059	0.77	1099	0.84	1138	0.92	1174	1.00	
<b>Continued</b>										<b>1-HP Standard Motor &amp; Field Supplied High Static Drive<sup>(ii)</sup></b>											
External Static Pressure (Inches of Water)																					
		1.10		1.20		1.30		1.40		1.50											
CFM	RPM	BHP	RPM	BHP	RPM	BHP	RPM	BHP	RPM	BHP											
<b>1-HP Standard Motor &amp; Drive</b>																					
960	1052	0.65	1086	0.71	1120	0.77	1152	0.83	1185	0.90											
1080	1090	0.75	1123	0.81	1154	0.87	1185	0.93	1215	0.99											
1200	1130	0.86	1162	0.92	1193	0.99	1224	1.05	1253	1.12											
1320	1169	0.96	1203	1.04	1233	1.12	1263	1.19	1292	1.26											
1440	1208	1.08	1241	1.16	1273	1.25	1303	1.33	1332	1.41											
<b>1-HP Standard Motor &amp; Field Supplied High Static Drive<sup>(iii)</sup></b>																					

For Standard Evaporator Fan Speed (RPM), reference [Table 123](#).  
 Notes:  
 Data includes pressure drop due to standard filters and wet coils. No accessories or options are included in pressure drop data. Refer to [Table 128](#) to determine additional static pressure drop due to other options/accessories.  
 Fan Motor Heat (MBH) = 2.829 x Fan BHP + .4024.  
 Factory supplied motors, in commercial equipment, are definite purpose motors, specifically designed and tested to operate reliably and continuously at all cataloged conditions. Using the full horsepower range of our fan motors as shown in our tabular data will not result in nuisance tripping or premature motor failure. Our product's warranty will not be affected.

<sup>(i)</sup> Field Supplied Fan Sheave AK69 required. Field Supplied Belt may be necessary.  
<sup>(ii)</sup> Field Supplied Fan Sheave AK41 required. Field Supplied Belt may be necessary.  
<sup>(iii)</sup> Field Supplied Fan Sheave AK41 required. Field Supplied Belt may be necessary.

**Table 34. Belt Drive Evaporator Fan Performance 3 Tons with Gas Heat YSC036A3,4,W\*H High Heat Horizontal Airflow**

External Static Pressure (Inches of Water)																					
		.10		.20		.30		.40		.50		.60		.70		.80		.90		1.00	
CFM	RPM	BHP	RPM	BHP	RPM	BHP	RPM	BHP	RPM	BHP	RPM	BHP	RPM	BHP	RPM	BHP	RPM	BHP	RPM	BHP	
<b>1-HP Standard Motor &amp; Field Supplied Low Static Drive<sup>(i)</sup></b>										<b>1-HP Standard Motor &amp; Drive</b>											
960	563	0.13	639	0.18	707	0.23	766	0.28	817	0.33	864	0.39	908	0.44	947	0.49	985	0.55	1020	0.60	
1080	611	0.18	685	0.23	748	0.28	806	0.34	858	0.39	905	0.45	947	0.51	988	0.58	1026	0.64	1061	0.70	
1200	660	0.23	732	0.29	792	0.34	847	0.40	899	0.46	945	0.53	989	0.59	1029	0.66	1066	0.73	1102	0.80	
1320	711	0.29	781	0.36	838	0.42	890	0.48	940	0.55	986	0.61	1029	0.68	1070	0.76	1106	0.83	1142	0.90	
1440	762	0.37	829	0.44	885	0.51	935	0.57	983	0.64	1028	0.71	1070	0.79	1111	0.86	1148	0.94	1183	1.02	
<b>Continued</b>										<b>1-HP Standard Motor &amp; Field Supplied High Static Drive<sup>(ii)</sup></b>											
External Static Pressure (Inches of Water)																					
		1.10		1.20		1.30		1.40		1.50											
CFM	RPM	BHP	RPM	BHP	RPM	BHP	RPM	BHP	RPM	BHP											
<b>1-HP Standard Motor &amp; Drive</b>																					
960	1056	0.66	1090	0.71	1123	0.78	1156	0.84	1188	0.90											
1080	1096	0.76	1128	0.82	1159	0.88	1190	0.94	1220	1.00											
1200	1135	0.87	1168	0.93	1199	1.00	1229	1.07	1259	1.13											
1320	1177	0.98	1209	1.06	1241	1.14	1270	1.21	1299	1.28											
1440	1217	1.10	1250	1.18	1281	1.27	1311	1.35	1339	1.43											
<b>1-HP Standard Motor &amp; Field Supplied High Static Drive<sup>(iii)</sup></b>																					

For Standard Evaporator Fan Speed (RPM), reference [Table 123](#).  
 Notes:  
 Data includes pressure drop due to standard filters and wet coils. No accessories or options are included in pressure drop data. Refer to [Table 128](#) to determine additional static pressure drop due to other options/accessories.  
 Fan Motor Heat (MBH) = 2.829 x Fan BHP + .4024.  
 Factory supplied motors, in commercial equipment, are definite purpose motors, specifically designed and tested to operate reliably and continuously at all cataloged conditions. Using the full horsepower range of our fan motors as shown in our tabular data will not result in nuisance tripping or premature motor failure. Our product's warranty will not be affected.

<sup>(i)</sup> Field Supplied Fan Sheave AK69 required. Field Supplied Belt may be necessary.  
<sup>(ii)</sup> Field Supplied Fan Sheave AK41 required. Field Supplied Belt may be necessary.  
<sup>(iii)</sup> Field Supplied Fan Sheave AK41 required. Field Supplied Belt may be necessary.

## Performance Data

*(4 Tons Standard Efficiency)*

**Table 35. Belt Drive Evaporator Fan Performance 4 Tons with Electric Heat TSC048A3,4,W Downflow Airflow**

External Static Pressure (Inches of Water)																				
CFM	.10		.20		.30		.40		.50		.60		.70		.80		.90		1.00	
	RPM	BHP	RPM	BHP	RPM	BHP	RPM	BHP	RPM	BHP	RPM	BHP	RPM	BHP	RPM	BHP	RPM	BHP	RPM	BHP
<b>1-HP Standard Motor &amp; Field Supplied Low Static Drive<sup>(i)</sup></b>										<b>1-HP Standard Motor &amp; Drive</b>										
1280	—	—	616	0.22	677	0.26	734	0.31	787	0.37	834	0.42	878	0.48	919	0.53	959	0.59	997	0.64
1440	596	0.23	663	0.29	719	0.33	772	0.38	823	0.44	871	0.51	914	0.57	954	0.63	993	0.69	1029	0.75
1600	647	0.31	711	0.37	764	0.42	813	0.47	860	0.53	906	0.59	951	0.66	992	0.74	1029	0.80	1065	0.87
1760	701	0.41	758	0.46	811	0.52	856	0.58	901	0.64	944	0.70	986	0.77	1027	0.85	1066	0.93	1102	1.00
1920	755	0.52	807	0.57	859	0.64	903	0.71	945	0.77	985	0.83	1024	0.89	1063	0.97	1101	1.05	1137	1.14
<b>Continued</b>																				
External Static Pressure (Inches of Water)																				
CFM	1.10		1.20		1.30		1.40		1.50											
	RPM	BHP	RPM	BHP	RPM	BHP	RPM	BHP	RPM	BHP										
<b>1-HP Standard Motor &amp; Drive</b>																				
1280	1033	0.70	1069	0.77	1103	0.83	1136	0.89	1170	0.96										
1440	1066	0.81	1099	0.87	1133	0.94	1165	1.01	1196	1.08										
1600	1099	0.93	1132	1.00	1166	1.07	1196	1.14	1228	1.21										
1760	1136	1.08	1168	1.15	1200	1.22	1229	1.29	—	—										
1920	1172	1.23	1205	1.31	1236	1.39	—	—	—	—										

For Standard Evaporator Fan Speed (RPM), reference [Table 123](#).  
Notes:  
Data includes pressure drop due to standard filters and wet coils. No accessories or options are included in pressure drop data. Refer to [Table 128](#) to determine additional static pressure drop due to other options/accessories.  
Fan Motor Heat (MBH) = 2.829 x Fan BHP + .4024.  
Factory supplied motors, in commercial equipment, are definite purpose motors, specifically designed and tested to operate reliably and continuously at all cataloged conditions. Using the full horsepower range of our fan motors as shown in our tabular data will not result in nuisance tripping or premature motor failure. Our product's warranty will not be affected.

<sup>(i)</sup> Field Supplied Fan Sheave AK61 required. Field Supplied Belt may be necessary.

**Table 36. Belt Drive Evaporator Fan Performance 4 Tons with Electric Heat TSC048A3,4,W Horizontal Airflow**

External Static Pressure (Inches of Water)																				
CFM	.10		.20		.30		.40		.50		.60		.70		.80		.90		1.00	
	RPM	BHP	RPM	BHP	RPM	BHP	RPM	BHP	RPM	BHP	RPM	BHP	RPM	BHP	RPM	BHP	RPM	BHP	RPM	BHP
<b>1-HP Standard Motor &amp; Field Supplied Low Static Drive<sup>(i)</sup></b>										<b>1-HP Standard Motor &amp; Drive</b>										
1280	604	0.20	683	0.26	756	0.32	816	0.39	869	0.45	920	0.51	967	0.57	1011	0.64	1052	0.71	1090	0.79
1440	660	0.28	731	0.34	800	0.41	862	0.48	914	0.54	963	0.61	1009	0.68	1053	0.76	1094	0.83	1133	0.91
1600	717	0.36	783	0.43	846	0.51	907	0.58	961	0.66	1008	0.73	1053	0.81	1095	0.89	1135	0.97	1174	1.05
1760	774	0.47	837	0.54	894	0.62	952	0.70	1006	0.79	1054	0.87	1098	0.95	1139	1.04	1178	1.12	1216	1.21
1920	833	0.59	892	0.67	946	0.76	998	0.85	1050	0.94	1100	1.03	1144	1.12	1185	1.21	1224	1.30	1259	1.39
											<b>1-HP Standard Motor &amp; Field Supplied High Static Drive<sup>(ii)</sup></b>									
External Static Pressure (Inches of Water)																				
CFM	1.10		1.20		1.30		1.40		1.50											
	RPM	BHP	RPM	BHP	RPM	BHP	RPM	BHP	RPM	BHP										
<b>1-HP Standard Motor &amp; Drive</b>																				
1280	1125	0.86	1160	0.94	1192	1.01	1223	1.08	1254	1.15										
1440	1169	0.98	1204	1.07	1237	1.15	1269	1.23	1300	1.32										
1600	1211	1.13	1247	1.21	1280	1.30	1312	1.39	1343	1.48										
1760	1253	1.30	1289	1.39	1322	1.47	—	—	—	—										
1920	1295	1.48	—	—	—	—	—	—	—	—										
											<b>1-HP Standard Motor &amp; Field Supplied High Static Drive</b>									

For Standard Evaporator Fan Speed (RPM), reference [Table 123](#).  
Notes:  
Data includes pressure drop due to standard filters and wet coils. No accessories or options are included in pressure drop data. Refer to [Table 128](#) to determine additional static pressure drop due to other options/accessories.  
Fan Motor Heat (MBH) = 2.829 x Fan BHP + .4024.  
Factory supplied motors, in commercial equipment, are definite purpose motors, specifically designed and tested to operate reliably and continuously at all cataloged conditions. Using the full horsepower range of our fan motors as shown in our tabular data will not result in nuisance tripping or premature motor failure. Our product's warranty will not be affected.

<sup>(i)</sup> Field Supplied Fan Sheave AK61 required. Field Supplied Belt may be necessary.

<sup>(ii)</sup> Field Supplied Fan Sheave AK41 required. Field Supplied Belt may be necessary.



## Performance Data

*(4 Tons Standard Efficiency)*

**Table 37. Belt Drive Evaporator Fan Performance 4 Tons with Gas Heat YSC048A3,4,W\*L,M Low & Medium Heat Downflow Airflow**

CFM	External Static Pressure (Inches of Water)																				
	.10		.20		.30		.40		.50		.60		.70		.80		.90		1.00		
	RPM	BHP	RPM	BHP	RPM	BHP	RPM	BHP	RPM	BHP	RPM	BHP	RPM	BHP	RPM	BHP	RPM	BHP	RPM	BHP	
<b>1-HP Standard Motor &amp; Field Supplied Low Static Drive<sup>(i)</sup></b>										<b>1-HP Standard Motor &amp; Drive</b>											
1280	604	0.21	666	0.25	724	0.30	778	0.36	826	0.41	870	0.47	911	0.52	952	0.58	990	0.63	1026	0.69	
1440	665	0.29	720	0.34	773	0.38	824	0.44	872	0.51	916	0.57	956	0.63	994	0.69	1030	0.75	1065	0.81	
1600	726	0.38	777	0.44	826	0.49	873	0.54	919	0.61	961	0.68	1002	0.75	1039	0.82	1074	0.89	1109	0.95	
1760	789	0.50	836	0.56	881	0.61	924	0.67	967	0.73	1008	0.81	1048	0.89	1085	0.97	1120	1.04	1154	1.12	
1920	851	0.63	896	0.70	938	0.76	978	0.82	1018	0.88	1057	0.96	1095	1.04	1131	1.13	1167	1.21	1199	1.30	
<b>Continued</b>																					
CFM	External Static Pressure (Inches of Water)																				
	1.10		1.20		1.30		1.40		1.50												
	RPM	BHP	RPM	BHP	RPM	BHP	RPM	BHP	RPM	BHP											
<b>1-HP Standard Motor &amp; Drive</b>																					
1280	1062	0.76	1097	0.82	1130	0.88	1163	0.95	1195	1.02											
1440	1100	0.88	1133	0.94	1166	1.01	1198	1.08	1228	1.15											
1600	1141	1.02	1173	1.09	1205	1.16	1235	1.23	1265	1.31											
1760	1185	1.19	1215	1.26	1246	1.33	1275	1.41	1304	1.49											
1920	1230	1.37	1260	1.45	—	—	—	—	—	—											
<b>1-HP Standard Motor &amp; Field Supplied High Static Drive<sup>(ii)</sup></b>																					

For Standard Evaporator Fan Speed (RPM), reference [Table 123](#).  
Notes:  
Data includes pressure drop due to standard filters and wet coils. No accessories or options are included in pressure drop data. Refer to [Table 128](#) to determine additional static pressure drop due to other options/accessories.  
Fan Motor Heat (MBH) = 2.829 x Fan BHP + .4024.  
Factory supplied motors, in commercial equipment, are definite purpose motors, specifically designed and tested to operate reliably and continuously at all cataloged conditions. Using the full horsepower range of our fan motors as shown in our tabular data will not result in nuisance tripping or premature motor failure. Our product's warranty will not be affected.

<sup>(i)</sup> Field Supplied Fan Sheave AK61 required. Field Supplied Belt may be necessary.  
<sup>(ii)</sup> Field Supplied Fan Sheave AK41 required. Field Supplied Belt may be necessary.

**Table 38. Belt Drive Evaporator Fan Performance 4 Tons with Gas Heat YSC048A3,4,W\*H High Heat Downflow Airflow**

CFM	External Static Pressure (Inches of Water)																				
	.10		.20		.30		.40		.50		.60		.70		.80		.90		1.00		
	RPM	BHP	RPM	BHP	RPM	BHP	RPM	BHP	RPM	BHP	RPM	BHP	RPM	BHP	RPM	BHP	RPM	BHP	RPM	BHP	
<b>1-HP Standard Motor &amp; Field Supplied Low Static Drive<sup>(i)</sup></b>										<b>1-HP Standard Motor Drive</b>											
1280	618	0.22	678	0.26	735	0.31	788	0.37	835	0.42	879	0.48	920	0.53	960	0.59	997	0.65	1034	0.71	
1440	680	0.30	735	0.35	787	0.40	838	0.46	884	0.52	926	0.59	966	0.64	1004	0.70	1040	0.77	1075	0.83	
1600	744	0.40	794	0.45	842	0.50	888	0.56	933	0.64	975	0.71	1015	0.78	1051	0.84	1086	0.91	1120	0.97	
1760	808	0.52	854	0.58	899	0.64	941	0.69	984	0.76	1024	0.84	1063	0.92	1099	1.00	1134	1.07	1167	1.14	
1920	873	0.66	916	0.73	957	0.79	997	0.85	1037	0.92	1075	0.99	1112	1.08	1148	1.17	1183	1.25	1214	1.33	
<b>Continued</b>																					
CFM	External Static Pressure (Inches of Water)																				
	1.10		1.20		1.30		1.40		1.50												
	RPM	BHP	RPM	BHP	RPM	BHP	RPM	BHP	RPM	BHP											
<b>1-HP Standard Motor &amp; Drive</b>																					
1280	1069	0.77	1104	0.83	1137	0.90	1169	0.96	1202	1.04											
1440	1109	0.89	1142	0.96	1174	1.03	1205	1.10	1236	1.17											
1600	1153	1.04	1184	1.11	1214	1.18	1244	1.26	1275	1.33											
1760	1197	1.22	1228	1.29	1258	1.36	1287	1.44	—	—											
1920	1245	1.41	1274	1.49	—	—	—	—	—	—											
<b>1-HP Standard Motor &amp; Field Supplied High Static Drive<sup>(ii)</sup></b>																					

For Standard Evaporator Fan Speed (RPM), reference [Table 123](#).  
Notes:  
Data includes pressure drop due to standard filters and wet coils. No accessories or options are included in pressure drop data. Refer to [Table 128](#) to determine additional static pressure drop due to other options/accessories.  
Fan Motor Heat (MBH) = 2.829 x Fan BHP + .4024.  
Factory supplied motors, in commercial equipment, are definite purpose motors, specifically designed and tested to operate reliably and continuously at all cataloged conditions. Using the full horsepower range of our fan motors as shown in our tabular data will not result in nuisance tripping or premature motor failure. Our product's warranty will not be affected.

<sup>(i)</sup> Field Supplied Fan Sheave AK61 required. Field Supplied Belt may be necessary.  
<sup>(ii)</sup> Field Supplied Fan Sheave AK41 required. Field Supplied Belt may be necessary.

## Performance Data

*(4 Tons Standard Efficiency)*

**Table 39. Belt Drive Evaporator Fan Performance 4 Tons with Gas Heat YSC048A3,4,W\*L,M Low & Medium Heat Horizontal Airflow**

CFM	External Static Pressure (Inches of Water)																			
	.10		.20		.30		.40		.50		.60		.70		.80		.90		1.00	
	RPM	BHP	RPM	BHP	RPM	BHP	RPM	BHP	RPM	BHP	RPM	BHP	RPM	BHP	RPM	BHP	RPM	BHP	RPM	BHP
<b>1-HP Standard Motor &amp; Field Supplied Low Static Drive<sup>(i)</sup></b>										<b>1-HP Standard Motor Drive</b>										
1280	669	0.25	744	0.31	805	0.37	860	0.44	911	0.50	959	0.56	1003	0.63	1045	0.70	1082	0.77	1119	0.85
1440	733	0.34	803	0.41	864	0.48	916	0.55	965	0.62	1011	0.69	1055	0.76	1096	0.83	1134	0.91	1171	0.99
1600	800	0.45	864	0.53	923	0.60	974	0.68	1021	0.75	1064	0.83	1106	0.91	1147	0.99	1185	1.07	1221	1.15
1760	868	0.58	926	0.67	982	0.75	1033	0.83	1079	0.92	1121	1.00	1161	1.08	1199	1.17	1237	1.26	1273	1.35
1920	937	0.74	989	0.83	1042	0.92	1092	1.01	1138	1.10	1179	1.19	1217	1.28	1254	1.38	1290	1.47	—	—

**1-HP Standard Motor & Field Supplied High Static Drive<sup>(ii)</sup>**

**Continued**

CFM	External Static Pressure (Inches of Water)									
	1.10		1.20		1.30		1.40		1.50	
	RPM	BHP	RPM	BHP	RPM	BHP	RPM	BHP	RPM	BHP
<b>1-HP Standard Motor &amp; Drive</b>										
1280	1154	0.92	1187	1.00	1218	1.07	1248	1.14	1277	1.21
1440	1205	1.07	1237	1.15	1270	1.24	1300	1.32	1330	1.40
1600	1256	1.23	1290	1.33	1322	1.42	—	—	—	—
1760	1307	1.43	—	—	—	—	—	—	—	—
1920	—	—	—	—	—	—	—	—	—	—

**1-HP Standard Motor & Field Supplied High Static Drive<sup>(iii)</sup>**

For Standard Evaporator Fan Speed (RPM), reference [Table 123](#).  
Notes:  
Data includes pressure drop due to standard filters and wet coils. No accessories or options are included in pressure drop data. Refer to [Table 128](#) to determine additional static pressure drop due to other options/accessories.  
Fan Motor Heat (MBH) = 2.829 x Fan BHP + .4024.  
Factory supplied motors, in commercial equipment, are definite purpose motors, specifically designed and tested to operate reliably and continuously at all cataloged conditions. Using the full horsepower range of our fan motors as shown in our tabular data will not result in nuisance tripping or premature motor failure. Our product's warranty will not be affected.

<sup>(i)</sup> Field Supplied Fan Sheave AK61 required. Field Supplied Belt may be necessary.  
<sup>(ii)</sup> Field Supplied Fan Sheave AK41 required. Field Supplied Belt may be necessary.  
<sup>(iii)</sup> Field Supplied Fan Sheave AK41 required. Field Supplied Belt may be necessary.

**Table 40. Belt Drive Evaporator Fan Performance 4 Tons with Gas Heat YSC048A3,4,W\*H High Heat Horizontal Airflow**

CFM	External Static Pressure (Inches of Water)																			
	.10		.20		.30		.40		.50		.60		.70		.80		.90		1.00	
	RPM	BHP	RPM	BHP	RPM	BHP	RPM	BHP	RPM	BHP	RPM	BHP	RPM	BHP	RPM	BHP	RPM	BHP	RPM	BHP
<b>1-HP Standard Motor &amp; Field Supplied Low Static Drive<sup>(i)</sup></b>										<b>1-HP Standard Motor Drive</b>										
1280	686	0.27	758	0.33	817	0.39	871	0.45	922	0.51	968	0.58	1013	0.64	1053	0.72	1091	0.79	1127	0.86
1440	753	0.36	821	0.43	878	0.50	930	0.57	977	0.63	1022	0.70	1066	0.78	1107	0.85	1145	0.93	1180	1.01
1600	821	0.48	884	0.55	941	0.63	990	0.70	1035	0.78	1078	0.86	1120	0.93	1160	1.02	1197	1.10	1234	1.18
1760	891	0.62	949	0.70	1004	0.78	1052	0.87	1096	0.95	1137	1.03	1176	1.12	1214	1.20	1251	1.29	1287	1.38
1920	962	0.78	1015	0.87	1067	0.97	1115	1.06	1158	1.15	1198	1.24	1235	1.33	1271	1.42	—	—	—	—

**1-HP Standard Motor & Field Supplied High Static Drive<sup>(ii)</sup>**

**Continued**

CFM	External Static Pressure (Inches of Water)									
	1.10		1.20		1.30		1.40		1.50	
	RPM	BHP	RPM	BHP	RPM	BHP	RPM	BHP	RPM	BHP
<b>1-HP Standard Motor &amp; Drive</b>										
1280	1160	0.94	1194	1.01	1224	1.08	1254	1.15	1283	1.22
1440	1214	1.09	1247	1.18	1278	1.26	1308	1.34	1338	1.43
1600	1268	1.26	1300	1.35	1331	1.44	—	—	—	—
1760	1321	1.47	—	—	—	—	—	—	—	—
1920	—	—	—	—	—	—	—	—	—	—

**1-HP Standard Motor & Field Supplied High Static Drive<sup>(iii)</sup>**

For Standard Evaporator Fan Speed (RPM), reference [Table 123](#).  
Notes:  
Data includes pressure drop due to standard filters and wet coils. No accessories or options are included in pressure drop data. Refer to [Table 128](#) to determine additional static pressure drop due to other options/accessories.  
Fan Motor Heat (MBH) = 2.829 x Fan BHP + .4024.  
Factory supplied motors, in commercial equipment, are definite purpose motors, specifically designed and tested to operate reliably and continuously at all cataloged conditions. Using the full horsepower range of our fan motors as shown in our tabular data will not result in nuisance tripping or premature motor failure. Our product's warranty will not be affected.

<sup>(i)</sup> Field Supplied Fan Sheave AK61 required. Field Supplied Belt may be necessary.  
<sup>(ii)</sup> Field Supplied Fan Sheave AK41 required. Field Supplied Belt may be necessary.  
<sup>(iii)</sup> Field Supplied Fan Sheave AK41 required. Field Supplied Belt may be necessary.

## Performance Data

*(5 Tons Standard Efficiency)*

**Table 41. Belt Drive Evaporator Fan Performance 5 Tons with Electric Heat TSC060A3,4,W Downflow Airflow**

		External Static Pressure (Inches of Water)																			
		.10		.20		.30		.40		.50		.60		.70		.80		.90		1.00	
CFM	RPM	BHP	RPM	BHP	RPM	BHP	RPM	BHP	RPM	BHP	RPM	BHP	RPM	BHP	RPM	BHP	RPM	BHP	RPM	BHP	
<b>1-HP Standard Motor &amp; Field Supplied Low Static Drive<sup>(1)</sup></b>										<b>1-HP Standard Motor &amp; Drive</b>											
1600	674	0.33	735	0.39	786	0.45	835	0.50	883	0.56	928	0.63	972	0.70	1011	0.77	1048	0.84	1084	0.90	
1800	743	0.46	801	0.52	849	0.59	894	0.65	937	0.70	979	0.77	1021	0.85	1060	0.93	1098	1.01	1134	1.09	
2000	813	0.61	866	0.68	914	0.76	956	0.83	995	0.89	1035	0.96	1073	1.02	1111	1.10	1147	1.19	1183	1.28	
2200	886	0.80	933	0.87	980	0.96	1019	1.03	1057	1.11	1093	1.18	1129	1.25	1164	1.33	1198	1.40	1233	1.50	
2400	959	1.03	1000	1.10	1045	1.19	1085	1.28	1121	1.36	1154	1.45	1188	1.53	1221	1.60	—	—	—	—	

**Continued**

		External Static Pressure (Inches of Water)									
		1.10		1.20		1.30		1.40		1.50	
CFM	RPM	BHP	RPM	BHP	RPM	BHP	RPM	BHP	RPM	BHP	
<b>1-HP Standard Motor &amp; Drive</b>											
1600	1117	0.97	1150	1.04	1183	1.11	1215	1.18	1244	1.25	—
1800	1167	1.16	1199	1.24	1230	1.31	1259	1.39	1289	1.47	—
2000	1216	1.37	1249	1.47	—	—	—	—	—	—	—
2200	—	—	—	—	—	—	—	—	—	—	—
2400	—	—	—	—	—	—	—	—	—	—	—

For Standard Evaporator Fan Speed (RPM), reference [Table 123](#).  
Notes:  
Data includes pressure drop due to standard filters and wet coils. No accessories or options are included in pressure drop data. Refer to [Table 128](#) to determine additional static pressure drop due to other options/accessories.  
Fan Motor Heat (MBH) = 2.829 x Fan BHP+.4024.  
Factory supplied motors, in commercial equipment, are definite purpose motors, specifically designed and tested to operate reliably and continuously at all cataloged conditions. Using the full horsepower range of our fan motors as shown in our tabular data will not result in nuisance tripping or premature motor failure. Our product's warranty will not be affected.

<sup>(1)</sup> Field Supplied Fan Sheave AK56 required. Field Supplied Belt may be necessary.

**Table 42. Belt Drive Evaporator Fan Performance 5 Tons with Electric Heat TSC060A3,4,W Horizontal Airflow**

		External Static Pressure (Inches of Water)																			
		.10		.20		.30		.40		.50		.60		.70		.80		.90		1.00	
CFM	RPM	BHP	RPM	BHP	RPM	BHP	RPM	BHP	RPM	BHP	RPM	BHP	RPM	BHP	RPM	BHP	RPM	BHP	RPM	BHP	
<b>1-HP Standard Motor &amp; Field Supplied Low Static Drive<sup>(1)</sup></b>										<b>1-HP Standard Motor Drive</b>											
1600	746	0.39	812	0.47	876	0.54	934	0.62	985	0.70	1032	0.77	1074	0.85	1117	0.93	1157	1.01	1196	1.09	
1800	824	0.54	883	0.62	940	0.70	996	0.79	1048	0.88	1094	0.96	1137	1.05	1176	1.14	1214	1.22	1252	1.31	
2000	902	0.72	957	0.80	1008	0.90	1059	0.99	1110	1.09	1157	1.19	1200	1.28	1239	1.38	1276	1.47	1311	1.50	
2200	981	0.93	1032	1.03	1080	1.13	1126	1.23	1173	1.34	1219	1.44	—	—	—	—	—	—	—	—	
2400	1061	1.19	1109	1.29	1153	1.40	1196	1.50	—	—	—	—	—	—	—	—	—	—	—	—	

**Continued**

		External Static Pressure (Inches of Water)									
		1.10		1.20		1.30		1.40		1.50	
CFM	RPM	BHP	RPM	BHP	RPM	BHP	RPM	BHP	RPM	BHP	
<b>1-HP Standard Motor &amp; Drive</b>											
1600	1232	1.18	1267	1.26	1299	1.35	1332	1.45	—	—	—
1800	1289	1.41	1323	1.50	—	—	—	—	—	—	—
2000	—	—	—	—	—	—	—	—	—	—	—
2200	—	—	—	—	—	—	—	—	—	—	—
2400	—	—	—	—	—	—	—	—	—	—	—

For Standard Evaporator Fan Speed (RPM), reference [Table 123](#).  
Notes:  
Data includes pressure drop due to standard filters and wet coils. No accessories or options are included in pressure drop data. Refer to [Table 128](#) to determine additional static pressure drop due to other options/accessories.  
Fan Motor Heat (MBH) = 2.829 x Fan BHP+.4024.  
Factory supplied motors, in commercial equipment, are definite purpose motors, specifically designed and tested to operate reliably and continuously at all cataloged conditions. Using the full horsepower range of our fan motors as shown in our tabular data will not result in nuisance tripping or premature motor failure. Our product's warranty will not be affected.

<sup>(1)</sup> Field Supplied Fan Sheave AK56 required. Field Supplied Belt may be necessary.

## Performance Data

*(5 Tons Standard Efficiency)*

**Table 43. Belt Drive Evaporator Fan Performance 5 Tons with Gas Heat YSC060A3,4,W\*L,M Low & Medium Heat Downflow Airflow**

CFM	External Static Pressure (Inches of Water)																			
	.10		.20		.30		.40		.50		.60		.70		.80		.90		1.00	
	RPM	BHP	RPM	BHP	RPM	BHP	RPM	BHP	RPM	BHP	RPM	BHP	RPM	BHP	RPM	BHP	RPM	BHP	RPM	BHP
<b>1-HP Standard Motor &amp; Field Supplied Low Static Drive<sup>(1)</sup></b>										<b>1-HP Standard Motor Drive</b>										
1600	747	0.40	797	0.46	846	0.51	893	0.57	938	0.64	981	0.72	1020	0.79	1056	0.85	1091	0.92	1125	0.99
1800	828	0.56	873	0.62	917	0.68	960	0.74	1002	0.81	1042	0.89	1081	0.97	1118	1.05	1152	1.13	1185	1.20
2000	909	0.75	951	0.82	992	0.89	1031	0.95	1069	1.01	1107	1.09	1144	1.18	1179	1.27	1213	1.37	1246	1.45
2200	992	0.98	1031	1.06	1068	1.13	1104	1.20	1139	1.27	1175	1.35	1209	1.43	—	—	—	—	—	—
2400	1075	1.26	1111	1.34	1145	1.42	1179	1.50	—	—	—	—	—	—	—	—	—	—	—	—

**Continued**

CFM	External Static Pressure (Inches of Water)									
	1.10		1.20		1.30		1.40		1.50	
	RPM	BHP	RPM	BHP	RPM	BHP	RPM	BHP	RPM	BHP
<b>1-HP Standard Motor &amp; Drive</b>										
1600	1158	1.05	1190	1.13	1221	1.20	1251	1.27	1281	1.35
1800	1216	1.28	1246	1.35	1276	1.43	—	—	—	—
2000	—	—	—	—	—	—	—	—	—	—
2200	—	—	—	—	—	—	—	—	—	—
2400	—	—	—	—	—	—	—	—	—	—

For Standard Evaporator Fan Speed (RPM), reference [Table 123](#).  
Notes:  
Data includes pressure drop due to standard filters and wet coils. No accessories or options are included in pressure drop data. Refer to [Table 128](#) to determine additional static pressure drop due to other options/accessories.  
Fan Motor Heat (MBH) = 2.829 x Fan BHP+.4024.  
Factory supplied motors, in commercial equipment, are definite purpose motors, specifically designed and tested to operate reliably and continuously at all cataloged conditions. Using the full horsepower range of our fan motors as shown in our tabular data will not result in nuisance tripping or premature motor failure. Our product's warranty will not be affected.

<sup>(1)</sup> Field Supplied Fan Sheave AK56 required. Field Supplied Belt may be necessary.

**Table 44. Belt Drive Evaporator Fan Performance 5 Tons with Gas Heat YSC060A3,4,W\*H High Heat Downflow Airflow**

CFM	External Static Pressure (Inches of Water)																			
	.10		.20		.30		.40		.50		.60		.70		.80		.90		1.00	
	RPM	BHP	RPM	BHP	RPM	BHP	RPM	BHP	RPM	BHP	RPM	BHP	RPM	BHP	RPM	BHP	RPM	BHP	RPM	BHP
<b>1-HP Standard Motor &amp; Field Supplied Low Static Drive<sup>(1)</sup></b>										<b>1-HP Standard Motor Drive</b>										
1600	764	0.42	814	0.47	862	0.53	909	0.60	953	0.67	994	0.74	1032	0.81	1069	0.88	1103	0.94	1136	1.01
1800	848	0.58	892	0.65	936	0.70	978	0.77	1020	0.84	1059	0.92	1098	1.01	1132	1.09	1166	1.16	1198	1.24
2000	932	0.79	973	0.86	1013	0.92	1051	0.98	1090	1.06	1127	1.14	1163	1.23	1197	1.32	1231	1.42	1262	1.50
2200	1017	1.03	1055	1.11	1091	1.18	1127	1.25	1162	1.32	1196	1.40	1231	1.49	—	—	—	—	—	—
2400	1103	1.32	1138	1.41	1171	1.49	—	—	—	—	—	—	—	—	—	—	—	—	—	—

**Continued**

CFM	External Static Pressure (Inches of Water)									
	1.10		1.20		1.30		1.40		1.50	
	RPM	BHP	RPM	BHP	RPM	BHP	RPM	BHP	RPM	BHP
<b>1-HP Standard Motor &amp; Drive</b>										
1600	1168	1.08	1201	1.15	1231	1.22	1261	1.30	1290	1.37
1800	1229	1.31	1259	1.39	1288	1.46	—	—	—	—
2000	—	—	—	—	—	—	—	—	—	—
2200	—	—	—	—	—	—	—	—	—	—
2400	—	—	—	—	—	—	—	—	—	—

For Standard Evaporator Fan Speed (RPM), reference [Table 123](#).  
Notes:  
Data includes pressure drop due to standard filters and wet coils. No accessories or options are included in pressure drop data. Refer to [Table 128](#) to determine additional static pressure drop due to other options/accessories.  
Fan Motor Heat (MBH) = 2.829 x Fan BHP+.4024.  
Factory supplied motors, in commercial equipment, are definite purpose motors, specifically designed and tested to operate reliably and continuously at all cataloged conditions. Using the full horsepower range of our fan motors as shown in our tabular data will not result in nuisance tripping or premature motor failure. Our product's warranty will not be affected.

<sup>(1)</sup> Field Supplied Fan Sheave AK56 required. Field Supplied Belt may be necessary.

## Performance Data

*(5 Tons Standard Efficiency)*

**Table 45. Belt Drive Evaporator Fan Performance 5 Tons with Gas Heat YSC060A3,4,W\*L,M Low & Medium Heat Horizontal Airflow**

CFM	External Static Pressure (Inches of Water)																			
	.10		.20		.30		.40		.50		.60		.70		.80		.90		1.00	
	RPM	BHP	RPM	BHP	RPM	BHP	RPM	BHP	RPM	BHP	RPM	BHP	RPM	BHP	RPM	BHP	RPM	BHP	RPM	BHP
<b>1-HP Standard Motor &amp; Field Supplied Low Static Drive<sup>(1)</sup></b>										<b>1-HP Standard Motor &amp; Drive</b>										
1600	825	0.48	889	0.56	946	0.64	996	0.71	1041	0.79	1084	0.87	1126	0.95	1166	1.03	1204	1.11	1240	1.20
1800	913	0.66	971	0.75	1025	0.84	1074	0.92	1117	1.01	1158	1.09	1197	1.18	1235	1.27	1272	1.36	1307	1.45
2000	1003	0.89	1054	0.98	1105	1.08	1153	1.18	1196	1.27	1235	1.37	1272	1.46	1308	1.50	—	—	—	—
2200	1094	1.16	1140	1.26	1187	1.37	1232	1.48	—	—	—	—	—	—	—	—	—	—	—	—
2400	1185	1.48	—	—	—	—	—	—	—	—	—	—	—	—	—	—	—	—	—	—

**Continued**

CFM	External Static Pressure (Inches of Water)									
	1.10		1.20		1.30		1.40		1.50	
	RPM	BHP	RPM	BHP	RPM	BHP	RPM	BHP	RPM	BHP
<b>1-HP Standard Motor &amp; Drive</b>										
1600	1274	1.28	1307	1.37	1338	1.46	—	—	—	—
1800	—	—	—	—	—	—	—	—	—	—
2000	—	—	—	—	—	—	—	—	—	—
2200	—	—	—	—	—	—	—	—	—	—
2400	—	—	—	—	—	—	—	—	—	—

For Standard Evaporator Fan Speed (RPM), reference [Table 123](#).  
Notes:  
Data includes pressure drop due to standard filters and wet coils. No accessories or options are included in pressure drop data. Refer to [Table 128](#) to determine additional static pressure drop due to other options/accessories.  
Fan Motor Heat (MBH) = 2.829 x Fan BHP+.4024.  
Factory supplied motors, in commercial equipment, are definite purpose motors, specifically designed and tested to operate reliably and continuously at all cataloged conditions. Using the full horsepower range of our fan motors as shown in our tabular data will not result in nuisance tripping or premature motor failure. Our product's warranty will not be affected.

<sup>(1)</sup> Field Supplied Fan Sheave AK56 required. Field Supplied Belt may be necessary.

**Table 46. Belt Drive Evaporator Fan Performance 5 Tons with Gas Heat YSC060A3,4,W\*H High Heat Horizontal Airflow**

CFM	External Static Pressure (Inches of Water)																			
	.10		.20		.30		.40		.50		.60		.70		.80		.90		1.00	
	RPM	BHP	RPM	BHP	RPM	BHP	RPM	BHP	RPM	BHP	RPM	BHP	RPM	BHP	RPM	BHP	RPM	BHP	RPM	BHP
<b>1-HP Standard Motor &amp; Field Supplied Low Static Drive<sup>(1)</sup></b>										<b>1-HP Standard Motor &amp; Drive</b>										
1600	847	0.51	910	0.59	964	0.66	1011	0.74	1056	0.82	1098	0.89	1140	0.97	1179	1.06	1217	1.14	1252	1.23
1800	938	0.70	995	0.79	1047	0.87	1093	0.96	1135	1.05	1175	1.13	1213	1.22	1251	1.31	1287	1.40	1323	1.49
2000	1030	0.94	1082	1.03	1131	1.13	1176	1.23	1217	1.32	1255	1.42	1292	1.50	—	—	—	—	—	—
2200	1123	1.23	1170	1.33	1216	1.44	—	—	—	—	—	—	—	—	—	—	—	—	—	—
2400	—	—	—	—	—	—	—	—	—	—	—	—	—	—	—	—	—	—	—	—

**Continued**

CFM	External Static Pressure (Inches of Water)									
	1.10		1.20		1.30		1.40		1.50	
	RPM	BHP	RPM	BHP	RPM	BHP	RPM	BHP	RPM	BHP
<b>1-HP Standard Motor &amp; Drive</b>										
1600	1285	1.31	1317	1.40	1348	1.49	—	—	—	—
1800	—	—	—	—	—	—	—	—	—	—
2000	—	—	—	—	—	—	—	—	—	—
2200	—	—	—	—	—	—	—	—	—	—
2400	—	—	—	—	—	—	—	—	—	—

For Standard Evaporator Fan Speed (RPM), reference [Table 123](#).  
Notes:  
Data includes pressure drop due to standard filters and wet coils. No accessories or options are included in pressure drop data. Refer to [Table 128](#) to determine additional static pressure drop due to other options/accessories.  
Fan Motor Heat (MBH) = 2.829 x Fan BHP+.4024.  
Factory supplied motors, in commercial equipment, are definite purpose motors, specifically designed and tested to operate reliably and continuously at all cataloged conditions. Using the full horsepower range of our fan motors as shown in our tabular data will not result in nuisance tripping or premature motor failure. Our product's warranty will not be affected.

<sup>(1)</sup> Field Supplied Fan Sheave AK56 required. Field Supplied Belt may be necessary.

## Performance Data

*(6 Tons Standard Efficiency)*

**Table 47. Belt Drive Evaporator Fan Performance 6 Tons with Electric Heat TSC072A3,4,W Downflow Airflow**

External Static Pressure (Inches of Water)																					
		.10		.20		.30		.40		.50		.60		.70		.80		.90		1.00	
CFM	RPM	BHP	RPM	BHP	RPM	BHP	RPM	BHP	RPM	BHP	RPM	BHP	RPM	BHP	RPM	BHP	RPM	BHP	RPM	BHP	
<b>1-HP Standard Motor &amp; Field Supplied Low Static Drive<sup>(i)</sup></b>											<b>1-HP Standard Motor &amp; Drive</b>										
1920	—	—	—	—	573	0.34	630	0.41	680	0.48	726	0.55	769	0.62	811	0.70	851	0.78	889	0.87	
2160	—	—	548	0.35	602	0.42	656	0.50	706	0.58	751	0.65	792	0.73	832	0.81	871	0.90	908	0.99	
2400	—	—	584	0.45	635	0.52	682	0.60	732	0.69	777	0.77	818	0.86	856	0.95	893	1.04	930	1.13	
2640	569	0.47	621	0.56	670	0.64	715	0.72	758	0.81	802	0.91	845	1.01	883	1.10	919	1.20	953	1.29	
2880	612	0.60	660	0.69	706	0.78	749	0.86	789	0.96	830	1.06	870	1.16	909	1.27	945	1.37	979	1.48	

Continued

External Static Pressure (Inches of Water)																					
		1.10		1.20		1.30		1.40		1.50		1.60		1.70		1.80		1.90		2.00	
CFM	RPM	BHP	RPM	BHP	RPM	BHP	RPM	BHP	RPM	BHP	RPM	BHP	RPM	BHP	RPM	BHP	RPM	BHP	RPM	BHP	
<b>1-HP Standard Motor &amp; Drive</b>						<b>1-HP Standard Motor &amp; High Static Drive Kit (or 2-HP Oversized Motor and Drive)</b>															
1920	925	0.95	960	1.03	994	1.11	1026	1.19	1057	1.27	1087	1.36	1116	1.44	1144	1.52	1173	1.61	1200	1.70	
2160	944	1.08	978	1.17	1010	1.26	1043	1.36	1073	1.44	1104	1.54	1133	1.63	1162	1.72	1189	1.81	1216	1.91	
2400	964	1.22	998	1.32	1030	1.42	1063	1.53	1092	1.63	1123	1.73	1151	1.83	1179	1.93	1206	2.03	1233	2.13	
2640	986	1.39	1019	1.49	1051	1.60	1082	1.71	1112	1.81	1141	1.92	1169	2.03	1198	2.15	1225	2.26	—	—	
2880	1011	1.58	1043	1.69	1073	1.79	1103	1.90	1133	2.02	1161	2.13	1190	2.26	—	—	—	—	—	—	

**2-HP Oversized Motor & Drive**

For Standard Evaporator Fan Speed (RPM), reference [Table 123](#).

Notes:

Data includes pressure drop due to standard filters and wet coils. No accessories or options are included in pressure drop data. Refer to [Table 128](#) to determine additional static pressure drop due to other options/accessories.

1-HP Fan Motor Heat (MBH) = 2.829 x Fan BHP + .4024. 2-HP Fan Motor Heat (MBH) = 3.000 x Fan BHP + .5000

Factory supplied motors, in commercial equipment, are definite purpose motors, specifically designed and tested to operate reliably and continuously at all cataloged conditions. Using the full horsepower range of our fan motors as shown in our tabular data will not result in nuisance tripping or premature motor failure. Our product's warranty will not be affected.

<sup>(i)</sup> Field Supplied Fan Sheave AK84 and Belt AX34 required.

**Table 48. Belt Drive Evaporator Fan Performance 6 Tons with Electric Heat TSC072A3,4,W Horizontal Airflow**

External Static Pressure (Inches of Water)																					
		.10		.20		.30		.40		.50		.60		.70		.80		.90		1.00	
CFM	RPM	BHP	RPM	BHP	RPM	BHP	RPM	BHP	RPM	BHP	RPM	BHP	RPM	BHP	RPM	BHP	RPM	BHP	RPM	BHP	
<b>1-HP Standard Motor &amp; Field Supplied Low Static Drive<sup>(i)</sup></b>											<b>1-HP Standard Motor &amp; Drive</b>										
1920	—	—	565	0.31	627	0.39	679	0.45	726	0.52	771	0.60	814	0.69	857	0.77	899	0.85	939	0.93	
2160	566	0.35	609	0.41	663	0.48	716	0.57	762	0.64	804	0.72	843	0.80	883	0.90	922	0.99	960	1.08	
2400	619	0.47	660	0.54	701	0.60	751	0.69	798	0.78	839	0.87	877	0.95	914	1.04	950	1.14	984	1.24	
2640	672	0.61	710	0.68	745	0.76	788	0.83	833	0.93	875	1.04	914	1.13	949	1.22	984	1.31	1016	1.42 <sup>(ii)</sup>	
2880	726	0.77	762	0.86	795	0.94	828	1.02	869	1.11	911	1.21	950	1.33	986	1.44	1019	1.53	1051	1.63	

Continued

External Static Pressure (Inches of Water)																					
		1.10		1.20		1.30		1.40		1.50		1.60		1.70		1.80		1.90		2.00	
CFM	RPM	BHP	RPM	BHP	RPM	BHP	RPM	BHP	RPM	BHP	RPM	BHP	RPM	BHP	RPM	BHP	RPM	BHP	RPM	BHP	
<b>1-HP Standard Motor &amp; Drive</b>						<b>1-HP Standard Motor &amp; High Static Drive Kit (or 2-HP Oversized Motor and Drive)</b>															
1920	978	1.02	1015	1.11	1051	1.20	1086	1.30	1118	1.39	1150	1.49	1180	1.58	1209	1.68	1236	1.77	1263	1.86	
2160	996	1.17	1034	1.27	1069	1.36	1103	1.46	1136	1.56	1169	1.67	1199	1.77	1229	1.88	1258	1.98	—	—	
2400	1020	1.35	1055	1.45	1089	1.55	1122	1.66	1154	1.76	1186	1.86	1216	1.97	1246	2.08	1276	2.20	—	—	
2640	1049	1.53	1081	1.65	1113	1.76	1144	1.87	1176	1.98	1207	2.10	1237	2.21	—	—	—	—	—	—	
2880	1081	1.74	1112	1.86	1141	1.97	1170	2.10	1199	2.22	—	—	—	—	—	—	—	—	—	—	

**2-HP Oversized Motor & Drive**

For Standard Evaporator Fan Speed (RPM), reference [Table 123](#).

Notes:

Data includes pressure drop due to standard filters and wet coils. No accessories or options are included in pressure drop data. Refer to [Table 128](#) to determine additional static pressure drop due to other options/accessories.

1-HP Fan Motor Heat (MBH) = 2.829 x Fan BHP + .4024. 2-HP Fan Motor Heat (MBH) = 3.000 x Fan BHP + .5000

Factory supplied motors, in commercial equipment, are definite purpose motors, specifically designed and tested to operate reliably and continuously at all cataloged conditions. Using the full horsepower range of our fan motors as shown in our tabular data will not result in nuisance tripping or premature motor failure. Our product's warranty will not be affected.

<sup>(i)</sup> Field Supplied Fan Sheave AK84 and Belt AX34 required.

<sup>(ii)</sup> 1-HP Standard Motor & High Static Drive Kit (or 2-HP Oversized Motor & Drive).

## Performance Data

*(6 Tons Standard Efficiency)*

**Table 49. Belt Drive Evaporator Fan Performance 6 Tons with Electric Heat TSC072AK Downflow Airflow**

CFM	External Static Pressure (Inches of Water)																			
	.10		.20		.30		.40		.50		.60		.70		.80		.90		1.00	
	RPM	BHP	RPM	BHP	RPM	BHP	RPM	BHP	RPM	BHP	RPM	BHP	RPM	BHP	RPM	BHP	RPM	BHP	RPM	BHP
<b>2-HP Standard Motor &amp; Field Supplied Low Static Drive<sup>(1)</sup></b>										<b>2-HP Standard Motor &amp; Drive</b>										
1920	—	—	—	—	573	0.34	630	0.41	680	0.48	726	0.55	769	0.62	811	0.70	851	0.78	889	0.87
2160	—	—	548	0.35	602	0.42	656	0.50	706	0.58	751	0.65	792	0.73	832	0.81	871	0.90	908	0.99
2400	—	—	584	0.45	635	0.52	682	0.60	732	0.69	777	0.77	818	0.86	856	0.95	893	1.04	930	1.13
2640	569	0.47	621	0.56	670	0.64	715	0.72	758	0.81	802	0.91	845	1.01	883	1.10	919	1.20	953	1.29
2880	612	0.60	660	0.69	706	0.78	749	0.86	789	0.96	830	1.06	870	1.16	909	1.27	945	1.37	979	1.48

Continued

CFM	External Static Pressure (Inches of Water)																			
	1.10		1.20		1.30		1.40		1.50		1.60		1.70		1.80		1.90		2.00	
	RPM	BHP	RPM	BHP	RPM	BHP	RPM	BHP	RPM	BHP	RPM	BHP	RPM	BHP	RPM	BHP	RPM	BHP	RPM	BHP
<b>2-HP Standard Motor &amp; Drive</b>										<b>2-HP Standard Motor &amp; High Static Drive</b>										
1920	925	0.95	960	1.03	994	1.11	1026	1.19	1057	1.27	1087	1.36	1116	1.44	1144	1.52	1173	1.61	1200	1.70
2160	944	1.08	978	1.17	1010	1.26	1043	1.36	1073	1.44	1104	1.54	1133	1.63	1162	1.72	1189	1.81	1216	1.91
2400	964	1.22	998	1.32	1030	1.42	1063	1.53	1092	1.63	1123	1.73	1151	1.83	1179	1.93	1206	2.03	1233	2.13
2640	986	1.39	1019	1.49	1051	1.60	1082	1.71	1112	1.81	1141	1.92	1169	2.03	1198	2.15	1225	2.26	—	—
2880	1011	1.58	1043	1.69	1073	1.79	1103	1.90	1133	2.02	1161	2.13	1190	2.26	—	—	—	—	—	—

For Standard Evaporator Fan Speed (RPM), reference [Table 123](#).

Notes:

Data includes pressure drop due to standard filters and wet coils. No accessories or options are included in pressure drop data.

Refer to [Table 128](#) to determine additional static pressure drop due to other options/accessories.

2-HP Fan Motor Heat (MBH) = 3.000 x Fan BHP + .5000

Factory supplied motors, in commercial equipment, are definite purpose motors, specifically designed and tested to operate reliably and continuously at all cataloged conditions. Using the full horsepower range of our fan motors as shown in our tabular data will not result in nuisance tripping or premature motor failure. Our product's warranty will not be affected.

<sup>(1)</sup> Field Supplied Fan Sheave AK84 and Belt AX34 required.

**Table 50. Belt Drive Evaporator Fan Performance 6 Tons with Electric Heat TSC072AK Horizontal Airflow**

CFM	External Static Pressure (Inches of Water)																			
	.10		.20		.30		.40		.50		.60		.70		.80		.90		1.00	
	RPM	BHP	RPM	BHP	RPM	BHP	RPM	BHP	RPM	BHP	RPM	BHP	RPM	BHP	RPM	BHP	RPM	BHP	RPM	BHP
<b>2-HP Standard Motor &amp; Field Supplied Low Static Drive<sup>(1)</sup></b>										<b>2-HP Standard Motor &amp; Drive</b>										
1920	—	—	565	0.31	627	0.39	679	0.45	726	0.52	771	0.60	814	0.69	857	0.77	899	0.85	939	0.93
2160	566	0.35	609	0.41	663	0.48	716	0.57	762	0.64	804	0.72	843	0.80	883	0.90	922	0.99	960	1.08
2400	619	0.47	660	0.54	701	0.60	751	0.69	798	0.78	839	0.87	877	0.95	914	1.04	950	1.14	984	1.24
2640	672	0.61	710	0.68	745	0.76	788	0.83	833	0.93	875	1.04	914	1.13	949	1.22	984	1.31	1016	1.42
2880	726	0.77	762	0.86	795	0.94	828	1.02	869	1.11	911	1.21	950	1.33	986	1.44	1019	1.53	1051	1.63

Continued

CFM	External Static Pressure (Inches of Water)																			
	1.10		1.20		1.30		1.40		1.50		1.60		1.70		1.80		1.90		2.00	
	RPM	BHP	RPM	BHP	RPM	BHP	RPM	BHP	RPM	BHP	RPM	BHP	RPM	BHP	RPM	BHP	RPM	BHP	RPM	BHP
<b>2-HP Standard Motor &amp; Drive</b>										<b>2-HP Standard Motor &amp; High Static Drive</b>										
1920	978	1.02	1015	1.11	1051	1.20	1086	1.30	1118	1.39	1150	1.49	1180	1.58	1209	1.68	1236	1.77	1263	1.86
2160	996	1.17	1034	1.27	1069	1.36	1103	1.46	1136	1.56	1169	1.67	1199	1.77	1229	1.88	1258	1.98	—	—
2400	1020	1.35	1055	1.45	1089	1.55	1122	1.66	1154	1.76	1186	1.86	1216	1.97	1246	2.08	1276	2.20	—	—
2640	1049	1.53	1081	1.65	1113	1.76	1144	1.87	1176	1.98	1207	2.10	1237	2.21	—	—	—	—	—	—
2880	1081	1.74	1112	1.86	1141	1.97	1170	2.10	1199	2.22	—	—	—	—	—	—	—	—	—	—

For Standard Evaporator Fan Speed (RPM), reference [Table 123](#).

Notes:

Data includes pressure drop due to standard filters and wet coils. No accessories or options are included in pressure drop data.

Refer to [Table 128](#) to determine additional static pressure drop due to other options/accessories.

2-HP Fan Motor Heat (MBH) = 3.000 x Fan BHP + .5000

Factory supplied motors, in commercial equipment, are definite purpose motors, specifically designed and tested to operate reliably and continuously at all cataloged conditions. Using the full horsepower range of our fan motors as shown in our tabular data will not result in nuisance tripping or premature motor failure. Our product's warranty will not be affected.

<sup>(1)</sup> Field Supplied Fan Sheave AK84 and Belt AX34 required.

## Performance Data

*(6 Tons Standard Efficiency)*

**Table 51. Belt Drive Evaporator Fan Performance 6 Tons with Gas Heat YSC072A3,A4,AW\*L,M Low & Medium Heat Downflow Airflow**

CFM	External Static Pressure (Inches of Water)																				
	.10		.20		.30		.40		.50		.60		.70		.80		.90		1.00		
RPM	BHP	RPM	BHP	RPM	BHP	RPM	BHP	RPM	BHP	RPM	BHP	RPM	BHP	RPM	BHP	RPM	BHP	RPM	BHP	RPM	BHP
<b>1-HP Standard Motor &amp; Field Supplied Low Static Drive<sup>(1)</sup></b>										<b>1-HP Standard Motor &amp; Drive</b>											
1920	—	—	—	—	583	0.35	638	0.42	687	0.49	732	0.56	777	0.64	817	0.71	857	0.80	895	0.88	
2160	—	—	559	0.36	613	0.43	666	0.51	715	0.59	759	0.67	800	0.75	841	0.83	879	0.92	915	1.01	
2400	—	—	597	0.46	647	0.54	695	0.62	743	0.71	788	0.80	828	0.88	866	0.97	902	1.06	938	1.15	
2640	585	0.49	636	0.59	684	0.66	728	0.75	772	0.84	815	0.94	856	1.03	894	1.13	930	1.23	963	1.32	
2880	629	0.63	677	0.73	722	0.81	763	0.89	803	0.99	844	1.09	884	1.20	923	1.31	958	1.41	990	1.51	

Continued

CFM	External Static Pressure (Inches of Water)																				
	1.10		1.20		1.30		1.40		1.50		1.60		1.70		1.80		1.90		2.00		
RPM	BHP	RPM	BHP	RPM	BHP	RPM	BHP	RPM	BHP	RPM	BHP	RPM	BHP	RPM	BHP	RPM	BHP	RPM	BHP	RPM	BHP
<b>1-HP Standard Motor &amp; Drive</b>										<b>1-HP Standard Motor &amp; High Static Drive Kit (or 2-HP Oversized Motor &amp; Drive)</b>											
1920	931	0.96	965	1.04	999	1.12	1030	1.20	1062	1.29	1092	1.37	1120	1.45	1150	1.54	1177	1.63	1204	1.71	
2160	951	1.10	984	1.19	1018	1.29	1049	1.37	1080	1.46	1110	1.55	1139	1.65	1168	1.74	1196	1.84	1222	1.93	
2400	973	1.25	1006	1.35	1039	1.45	1070	1.55	1100	1.65	1129	1.76	1158	1.86	1186	1.96	1213	2.06	1241	2.16	
2640	996	1.42	1029	1.52	1060	1.63	1091	1.74	1121	1.85	1150	1.96	1178	2.07	1206	2.18	1233	2.30	—	—	
2880	1023	1.62	1054	1.72	1085	1.83	1114	1.95	1143	2.06	1172	2.18	1200	2.30	—	—	—	—	—	—	

**2-HP Oversized Motor & Drive**

For Standard Evaporator Fan Speed (RPM), reference [Table 123](#).

Notes:

Data includes pressure drop due to standard filters and wet coils. No accessories or options are included in pressure drop data.

Refer to [Table 128](#) to determine additional static pressure drop due to other options/accessories.

1-HP Fan Motor Heat (MBH) = 2.829 x Fan BHP+.4024. 2-HP Fan Motor Heat (MBH) = 3.000 x Fan BHP+.5000

Factory supplied motors, in commercial equipment, are definite purpose motors, specifically designed and tested to operate reliably and continuously at all cataloged conditions. Using the full horsepower range of our fan motors as shown in our tabular data will not result in nuisance tripping or premature motor failure. Our product's warranty will not be affected.

<sup>(1)</sup> Field Supplied Fan Sheave AK84 and Belt AX34 required.

**Table 52. Belt Drive Evaporator Fan Performance 6 Tons with Gas Heat YSC072A3,A4,AW\*H High Heat Downflow Airflow**

CFM	External Static Pressure (Inches of Water)																				
	.10		.20		.30		.40		.50		.60		.70		.80		.90		1.00		
RPM	BHP	RPM	BHP	RPM	BHP	RPM	BHP	RPM	BHP	RPM	BHP	RPM	BHP	RPM	BHP	RPM	BHP	RPM	BHP	RPM	BHP
<b>1-HP Standard Motor &amp; Field Supplied Low Static Drive<sup>(1)</sup></b>										<b>1-HP Standard Motor &amp; Drive</b>											
1920	—	—	559	0.32	618	0.39	668	0.46	715	0.53	759	0.61	802	0.69	842	0.77	881	0.85	917	0.93	
2160	—	—	600	0.42	654	0.49	705	0.57	749	0.65	791	0.73	831	0.81	870	0.90	907	0.99	943	1.08	
2400	594	0.46	644	0.53	692	0.61	741	0.70	786	0.79	826	0.88	864	0.97	900	1.05	936	1.15	971	1.24	
2640	643	0.60	691	0.67	734	0.76	778	0.85	822	0.95	862	1.05	899	1.14	935	1.24	967	1.33	1001	1.43	
2880	693	0.76	737	0.84	778	0.93	818	1.03	858	1.13	898	1.24	935	1.35	970	1.45	1003	1.55	1034	1.66	

Continued

CFM	External Static Pressure (Inches of Water)																				
	1.10		1.20		1.30		1.40		1.50		1.60		1.70		1.80		1.90		2.00		
RPM	BHP	RPM	BHP	RPM	BHP	RPM	BHP	RPM	BHP	RPM	BHP	RPM	BHP	RPM	BHP	RPM	BHP	RPM	BHP	RPM	BHP
<b>1-HP Standard Motor &amp; High Static Drive Kit (or 2-HP Oversized Motor &amp; Drive)</b>																					
1920	952	1.01	985	1.09	1019	1.17	1050	1.26	1080	1.34	1110	1.42	1139	1.51	1167	1.60	1192	1.68	1220	1.77	
2160	977	1.17	1010	1.26	1043	1.36	1073	1.44	1103	1.53	1133	1.63	1161	1.72	1189	1.81	1216	1.91	1242	2.00	
2400	1004	1.34	1037	1.44	1068	1.55	1099	1.65	1128	1.75	1156	1.85	1185	1.95	1212	2.05	1239	2.16	1265	2.26	
2640	1033	1.54	1064	1.64	1095	1.75	1125	1.87	1153	1.97	1182	2.09	1210	2.20	—	—	—	—	—	—	
2880	1065	1.76	1096	1.88	1124	1.99	1153	2.10	1182	2.22	—	—	—	—	—	—	—	—	—	—	

**2-HP Oversized Motor & Drive**

For Standard Evaporator Fan Speed (RPM), reference [Table 123](#).

Notes:

Data includes pressure drop due to standard filters and wet coils. No accessories or options are included in pressure drop data.

Refer to [Table 128](#) to determine additional static pressure drop due to other options/accessories.

1-HP Fan Motor Heat (MBH) = 2.829 x Fan BHP+.4024. 2-HP Fan Motor Heat (MBH) = 3.000 x Fan BHP+.5000

Factory supplied motors, in commercial equipment, are definite purpose motors, specifically designed and tested to operate reliably and continuously at all cataloged conditions. Using the full horsepower range of our fan motors as shown in our tabular data will not result in nuisance tripping or premature motor failure. Our product's warranty will not be affected.

<sup>(1)</sup> Field Supplied Fan Sheave AK84 and Belt AX34 required.



## Performance Data

*(6 Tons Standard Efficiency)*

**Table 53. Belt Drive Evaporator Fan Performance 6 Tons with Gas Heat YSC072A3,4,W\*L Low Heat Downflow Airflow**

CFM	External Static Pressure (Inches of Water)																			
	.10		.20		.30		.40		.50		.60		.70		.80		.90		1.00	
	RPM	BHP	RPM	BHP	RPM	BHP	RPM	BHP	RPM	BHP	RPM	BHP	RPM	BHP	RPM	BHP	RPM	BHP	RPM	BHP
<b>2-HP Standard Motor &amp; Field Supplied Low Static Drive<sup>(1)</sup></b>										<b>2-HP Standard Motor &amp; Drive</b>										
1920	—	—	—	—	583	0.35	638	0.42	687	0.49	732	0.56	777	0.64	817	0.71	857	0.80	895	0.88
2160	—	—	559	0.36	613	0.43	666	0.51	715	0.59	759	0.67	800	0.75	841	0.83	879	0.92	915	1.01
2400	—	—	597	0.46	647	0.54	695	0.62	743	0.71	788	0.80	828	0.88	866	0.97	902	1.06	938	1.15
2640	585	0.49	636	0.59	684	0.66	728	0.75	772	0.84	815	0.94	856	1.03	894	1.13	930	1.23	963	1.32
2880	629	0.63	677	0.73	722	0.81	763	0.89	803	0.99	844	1.09	884	1.20	923	1.31	958	1.41	990	1.51

Continued

CFM	External Static Pressure (Inches of Water)																			
	1.10		1.20		1.30		1.40		1.50		1.60		1.70		1.80		1.90		2.00	
	RPM	BHP	RPM	BHP	RPM	BHP	RPM	BHP	RPM	BHP	RPM	BHP	RPM	BHP	RPM	BHP	RPM	BHP	RPM	BHP
<b>2-HP Standard Motor &amp; Drive</b>										<b>2-HP Standard Motor &amp; High Static Drive</b>										
1920	931	0.96	965	1.04	999	1.12	1030	1.20	1062	1.29	1092	1.37	1120	1.45	1150	1.54	1177	1.63	1204	1.71
2160	951	1.10	984	1.19	1018	1.29	1049	1.37	1080	1.46	1110	1.55	1139	1.65	1168	1.74	1196	1.84	1222	1.93
2400	973	1.25	1006	1.35	1039	1.45	1070	1.55	1100	1.65	1129	1.76	1158	1.86	1186	1.96	1213	2.06	1241	2.16
2640	996	1.42	1029	1.52	1060	1.63	1091	1.74	1121	1.85	1150	1.96	1178	2.07	1206	2.18	1233	2.30	—	—
2880	1023	1.62	1054	1.72	1085	1.83	1114	1.95	1143	2.06	1172	2.18	1200	2.30	—	—	—	—	—	—

For Standard Evaporator Fan Speed (RPM), reference [Table 123](#).

Notes:

Data includes pressure drop due to standard filters and wet coils. No accessories or options are included in pressure drop data.

Refer to [Table 128](#) to determine additional static pressure drop due to other options/accessories.

2-HP Fan Motor Heat (MBH) = 3.000 x Fan BHP + .5000.

Factory supplied motors, in commercial equipment, are definite purpose motors, specifically designed and tested to operate reliably and continuously at all cataloged conditions. Using the full horsepower range of our fan motors as shown in our tabular data will not result in nuisance tripping or premature motor failure. Our product's warranty will not be affected.

<sup>(1)</sup> Field Supplied Fan Sheave AK84 and Belt AX34 required.

**Table 54. Belt Drive Evaporator Fan Performance 6 Tons with Gas Heat YSC072AK\*H High Heat Downflow Airflow**

CFM	External Static Pressure (Inches of Water)																			
	.10		.20		.30		.40		.50		.60		.70		.80		.90		1.00	
	RPM	BHP	RPM	BHP	RPM	BHP	RPM	BHP	RPM	BHP	RPM	BHP	RPM	BHP	RPM	BHP	RPM	BHP	RPM	BHP
<b>2-HP Standard Motor &amp; Field Supplied Low Static Drive<sup>(1)</sup></b>										<b>2-HP Standard Motor &amp; Drive</b>										
1920	—	—	559	0.32	618	0.39	668	0.46	715	0.53	759	0.61	802	0.69	842	0.77	881	0.85	917	0.93
2160	—	—	600	0.42	654	0.49	705	0.57	749	0.65	791	0.73	831	0.81	870	0.90	907	0.99	943	1.08
2400	594	0.46	644	0.53	692	0.61	741	0.70	786	0.79	826	0.88	864	0.97	900	1.05	936	1.15	971	1.24
2640	643	0.60	691	0.67	734	0.76	778	0.85	822	0.95	862	1.05	899	1.14	935	1.24	967	1.33	1001	1.43
2880	693	0.76	737	0.84	778	0.93	818	1.03	858	1.13	898	1.24	935	1.35	970	1.45	1003	1.55	1034	1.66

Continued

CFM	External Static Pressure (Inches of Water)																			
	1.10		1.20		1.30		1.40		1.50		1.60		1.70		1.80		1.90		2.00	
	RPM	BHP	RPM	BHP	RPM	BHP	RPM	BHP	RPM	BHP	RPM	BHP	RPM	BHP	RPM	BHP	RPM	BHP	RPM	BHP
<b>2-HP Standard Motor &amp; Drive</b>										<b>2-HP Standard Motor &amp; High Static Drive</b>										
1920	952	1.01	985	1.09	1019	1.17	1050	1.26	1080	1.34	1110	1.42	1139	1.51	1167	1.60	1192	1.68	1220	1.77
2160	977	1.17	1010	1.26	1043	1.36	1073	1.44	1103	1.53	1133	1.63	1161	1.72	1189	1.81	1216	1.91	1242	2.00
2400	1004	1.34	1037	1.44	1068	1.55	1099	1.65	1128	1.75	1156	1.85	1185	1.95	1212	2.05	1239	2.16	1265	2.26
2640	1033	1.54	1064	1.64	1095	1.75	1125	1.87	1153	1.97	1182	2.09	1210	2.20	—	—	—	—	—	—
2880	1065	1.76	1096	1.88	1124	1.99	1153	2.10	1182	2.22	—	—	—	—	—	—	—	—	—	—

For Standard Evaporator Fan Speed (RPM), reference [Table 123](#).

Notes:

Data includes pressure drop due to standard filters and wet coils.

No accessories or options are included in pressure drop data.

Refer to [Table 128](#) to determine additional static pressure drop due to other options/accessories.

2-HP Fan Motor Heat (MBH) = 3.000 x Fan BHP + .5000.

Factory supplied motors, in commercial equipment, are definite purpose motors, specifically designed and tested to operate reliably and continuously at all cataloged conditions. Using the full horsepower range of our fan motors as shown in our tabular data will not result in nuisance tripping or premature motor failure. Our product's warranty will not be affected.

<sup>(1)</sup> Field Supplied Fan Sheave AK84 and Belt AX34 required.

## Performance Data

*(6 Tons Standard Efficiency)*

**Table 55. Belt Drive Evaporator Fan Performance 6 Tons with Gas Heat YSC072A3,4,W\*L,M Low & Medium Heat Horizontal Airflow**

External Static Pressure (Inches of Water)																					
		.10		.20		.30		.40		.50		.60		.70		.80		.90		1.00	
CFM	RPM	BHP	RPM	BHP	RPM	BHP	RPM	BHP	RPM	BHP	RPM	BHP	RPM	BHP	RPM	BHP	RPM	BHP	RPM	BHP	
<b>1-HP Standard Motor &amp; Field Supplied Low Static Drive<sup>(i)</sup></b>											<b>1-HP Standard Motor &amp; Drive</b>										
1920	—	—	576	0.32	636	0.40	687	0.46	733	0.54	778	0.62	821	0.70	864	0.78	906	0.86	946	0.95	
2160	575	0.37	619	0.43	674	0.50	726	0.59	770	0.66	812	0.74	852	0.82	890	0.92	930	1.01	968	1.10	
2400	629	0.49	669	0.55	713	0.62	763	0.71	809	0.81	849	0.89	887	0.97	923	1.06	959	1.16	994	1.27	
2640	684	0.63	721	0.71	757	0.78	802	0.86	846	0.96	888	1.07	925	1.16	959	1.25	993	1.34	1027	1.45 <sup>(ii)</sup>	
2880	740	0.80	774	0.89	807	0.97	843	1.05	885	1.14	925	1.26	964	1.38	998	1.48	1030	1.57	1062	1.67	
											<b>2-HP Oversized Motor &amp; Drive</b>										

Continued

External Static Pressure (Inches of Water)																					
		1.10		1.20		1.30		1.40		1.50		1.60		1.70		1.80		1.90		2.00	
CFM	RPM	BHP	RPM	BHP	RPM	BHP	RPM	BHP	RPM	BHP	RPM	BHP	RPM	BHP	RPM	BHP	RPM	BHP	RPM	BHP	
<b>1-HP Standard Motor &amp; Drive</b>											<b>1-HP Standard Motor &amp; High Static Drive (or 2-HP Oversized Motor &amp; Drive)</b>										
1920	985	1.04	1020	1.13	1057	1.22	1090	1.31	1123	1.41	1155	1.50	1185	1.60	1213	1.69	1241	1.79	1268	1.88	
2160	1005	1.19	1040	1.29	1075	1.38	1110	1.48	1143	1.59	1176	1.69	1206	1.80	1235	1.90	1264	2.00	—	—	
2400	1029	1.37	1063	1.47	1098	1.58	1130	1.68	1162	1.78	1194	1.89	1223	2.00	1254	2.11	—	—	—	—	
2540	1058	1.56	1090	1.68	1121	1.79	1152	1.90	1184	2.01	1214	2.13	1244	2.24	—	—	—	—	—	—	
2880	1093	1.78	1123	1.90	1152	2.02	1181	2.14	1211	2.27	—	—	—	—	—	—	—	—	—	—	
											<b>2-HP Oversized Motor &amp; Drive</b>										

For Standard Evaporator Fan Speed (RPM), reference [Table 123](#). Notes: Data includes pressure drop due to standard filters and wet coils. No accessories or options are included in pressure drop data. Refer to [Table 128](#) to determine additional static pressure drop due to other options/accessories.

1-HP Fan Motor Heat (MBH) = 2.829 x Fan BHP+.4024.

2-HP Fan Motor Heat (MBH) = 3.000 x Fan BHP+.5000.

Factory supplied motors, in commercial equipment, are definite purpose motors, specifically designed and tested to operate reliably and continuously at all cataloged conditions. Using the full horsepower range of our fan motors as shown in our tabular data will not result in nuisance tripping or premature motor failure. Our product's warranty will not be affected.

<sup>(i)</sup> Field Supplied Fan Sheave AK84 and Belt AX34 required.

<sup>(ii)</sup> 1-HP Standard Motor & High Static Drive (or 2-HP Oversized Motor).

**Table 56. Belt Drive Evaporator Fan Performance 6 Tons with Gas Heat YSC072A3,4,W\*H High Heat Horizontal Airflow**

External Static Pressure (Inches of Water)																					
		.10		.20		.30		.40		.50		.60		.70		.80		.90		1.00	
CFM	RPM	BHP	RPM	BHP	RPM	BHP	RPM	BHP	RPM	BHP	RPM	BHP	RPM	BHP	RPM	BHP	RPM	BHP	RPM	BHP	
<b>1-HP Standard Motor &amp; Field Supplied Low Static Drive<sup>(i)</sup></b>											<b>1-HP Standard Motor &amp; Drive</b>										
1920	551	0.30	613	0.37	668	0.44	715	0.51	761	0.58	804	0.67	847	0.75	890	0.83	930	0.92	969	1.00	
2160	608	0.41	661	0.48	714	0.56	760	0.64	802	0.72	842	0.80	882	0.90	920	0.99	958	1.08	996	1.17	
2400	667	0.55	710	0.62	760	0.71	806	0.80	847	0.88	885	0.96	921	1.06	957	1.16	992	1.27	1027	1.37 <sup>(ii)</sup>	
2640	726	0.72	762	0.79	809	0.87	853	0.98	894	1.09	930	1.17	965	1.26	998	1.36	1031	1.47	1063	1.58	
2880	786	0.91	818	0.99	857	1.08	900	1.18	939	1.30	976	1.41	1009	1.51	1042	1.61	1073	1.71	1103	1.82	
											<b>2-HP Oversized Motor &amp; Drive</b>										

Continued

External Static Pressure (Inches of Water)																					
		1.10		1.20		1.30		1.40		1.50		1.60		1.70		1.80		1.90		2.00	
CFM	RPM	BHP	RPM	BHP	RPM	BHP	RPM	BHP	RPM	BHP	RPM	BHP	RPM	BHP	RPM	BHP	RPM	BHP	RPM	BHP	
<b>1-HP Standard Motor &amp; High Static Drive Kit (or 2-HP Oversized Motor &amp; Drive)</b>																					
1920	1007	1.09	1044	1.19	1078	1.28	1111	1.37	1142	1.46	1172	1.56	1203	1.65	1230	1.75	1257	1.84	—	—	
2160	1032	1.26	1068	1.36	1102	1.46	1135	1.56	1167	1.66	1198	1.77	1229	1.88	1259	1.98	—	—	—	—	
2400	1061	1.47	1095	1.57	1128	1.67	1161	1.78	1191	1.88	1223	2.00	1254	2.11	1282	2.23	—	—	—	—	
2640	1095	1.70	1126	1.81	1157	1.92	1189	2.03	1219	2.15	1250	2.26	—	—	—	—	—	—	—	—	
2880	1133	1.94	1162	2.06	1191	2.19	1221	2.30	—	—	—	—	—	—	—	—	—	—	—	—	
											<b>2-HP Oversized Motor &amp; Drive</b>										

For Standard Evaporator Fan Speed (RPM), reference [Table 123](#).

Notes: Data includes pressure drop due to standard filters and wet coils. No accessories or options are included in pressure drop data. Refer to [Table 128](#) to determine additional static pressure drop due to other options/accessories. 1-HP Fan Motor Heat (MBH) = 2.829 x Fan BHP+.4024. 2-HP Fan Motor Heat (MBH) = 3.000 x Fan BHP+.5000.

Factory supplied motors, in commercial equipment, are definite purpose motors, specifically designed and tested to operate reliably and continuously at all cataloged conditions. Using the full horsepower range of our fan motors as shown in our tabular data will not result in nuisance tripping or premature motor failure. Our product's warranty will not be affected.

<sup>(i)</sup> Field Supplied Fan Sheave AK61 required. Field Supplied Belt may be necessary.

<sup>(ii)</sup> 1-HP Standard Motor & High Static Drive (or 2-HP Oversized Motor).

## Performance Data

*(6 Tons Standard Efficiency)*

**Table 57. Belt Drive Evaporator Fan Performance 6 Tons with Gas Heat YSC072AK\*L Low Heat Horizontal Airflow**

External Static Pressure (Inches of Water)																								
		.10		.20		.30		.40		.50		.60		.70		.80		.90		1.00				
CFM	RPM	BHP	RPM	BHP	RPM	BHP	RPM	BHP	RPM	BHP	RPM	BHP	RPM	BHP	RPM	BHP	RPM	BHP	RPM	BHP	RPM	BHP		
<b>2-HP Standard Motor &amp; Low Static Drive</b>											<b>2-HP Standard Motor &amp; Drive</b>													
1920	522	0.27	576	0.32	636	0.40	687	0.46	733	0.54	778	0.62	821	0.70	864	0.78	906	0.86	946	0.95				
2160	575	0.37	619	0.43	674	0.50	726	0.59	770	0.66	812	0.74	852	0.82	890	0.92	930	1.01	968	1.10				
2400	629	0.49	669	0.55	713	0.62	763	0.71	809	0.81	849	0.89	887	0.97	923	1.06	959	1.16	994	1.27				
2640	684	0.63	721	0.71	757	0.78	802	0.86	846	0.96	888	1.07	925	1.16	959	1.25	993	1.34	1027	1.45				
2880	740	0.80	774	0.89	807	0.97	843	1.05	885	1.14	925	1.26	964	1.38	998	1.48	1030	1.57	1062	1.67				
											<b>2-HP Standard Motor &amp; High Static Drive</b>													

Continued

External Static Pressure (Inches of Water)																								
		1.10		1.20		1.30		1.40		1.50		1.60		1.70		1.80		1.90		2.00				
CFM	RPM	BHP	RPM	BHP	RPM	BHP	RPM	BHP	RPM	BHP	RPM	BHP	RPM	BHP	RPM	BHP	RPM	BHP	RPM	BHP	RPM	BHP		
<b>2-HP Standard Motor &amp; Drive</b>						<b>2-HP Standard Motor &amp; High Static Drive Kit</b>																		
1920	985	1.04	1020	1.13	1057	1.22	1090	1.31	1123	1.41	1155	1.50	1185	1.60	1213	1.69	1241	1.79	1268	1.88				
2160	1005	1.19	1040	1.29	1075	1.38	1110	1.48	1143	1.59	1176	1.69	1206	1.80	1235	1.90	1264	2.00	—	—				
2400	1029	1.37	1063	1.47	1098	1.58	1130	1.68	1162	1.78	1194	1.89	1223	2.00	1254	2.11	—	—	—	—				
2640	1058	1.56	1090	1.68	1121	1.79	1152	1.90	1184	2.01	1214	2.13	1244	2.24	—	—	—	—	—	—				
2880	1093	1.78	1123	1.90	1152	2.02	1181	2.14	1211	2.27	—	—	—	—	—	—	—	—	—	—				

For Standard Evaporator Fan Speed (RPM), reference [Table 123](#).

Notes:

Data includes pressure drop due to standard filters and wet coils. No accessories or options are included in pressure drop data.

Refer to [Table 128](#) to determine additional static pressure drop due to other options/accessories.

2-HP Fan Motor Heat (MBH) = 3.000 x Fan BHP + .5000.

Factory supplied motors, in commercial equipment, are definite purpose motors, specifically designed and tested to operate reliably and continuously at all cataloged conditions. Using the full horsepower range of our fan motors as shown in our tabular data will not result in nuisance tripping or premature motor failure. Our product's warranty will not be affected.

**Table 58. Belt Drive Evaporator Fan Performance 6 Tons with Gas Heat YSC072AK\*H High Heat Horizontal Airflow**

External Static Pressure (Inches of Water)																								
		.10		.20		.30		.40		.50		.60		.70		.80		.90		1.00				
CFM	RPM	BHP	RPM	BHP	RPM	BHP	RPM	BHP	RPM	BHP	RPM	BHP	RPM	BHP	RPM	BHP	RPM	BHP	RPM	BHP	RPM	BHP		
<b>2-HP Standard Motor &amp; Field Supplied Low Static Drive<sup>(1)</sup></b>											<b>2-HP Standard Motor &amp; Drive</b>													
1920	551	0.30	613	0.37	668	0.44	715	0.51	761	0.58	804	0.67	847	0.75	890	0.83	930	0.92	969	1.00				
2160	608	0.41	661	0.48	714	0.56	760	0.64	802	0.72	842	0.80	882	0.90	920	0.99	958	1.08	996	1.17				
2400	667	0.55	710	0.62	760	0.71	806	0.80	847	0.88	885	0.96	921	1.06	957	1.16	992	1.27	1027	1.37				
2640	726	0.72	762	0.79	809	0.87	853	0.98	894	1.09	930	1.17	965	1.26	998	1.36	1031	1.47	1063	1.58				
2880	786	0.91	818	0.99	857	1.08	900	1.18	939	1.30	976	1.41	1009	1.51	1042	1.61	1073	1.71	1103	1.82				
											<b>2-HP Standard Motor &amp; High Static Drive</b>													

Continued

External Static Pressure (Inches of Water)																								
		1.10		1.20		1.30		1.40		1.50		1.60		1.70		1.80		1.90		2.00				
CFM	RPM	BHP	RPM	BHP	RPM	BHP	RPM	BHP	RPM	BHP	RPM	BHP	RPM	BHP	RPM	BHP	RPM	BHP	RPM	BHP	RPM	BHP		
<b>2-HP Standard Motor &amp; High Static Drive Kit</b>																								
1920	1007	1.09	1044	1.19	1078	1.28	1111	1.37	1142	1.46	1172	1.56	1203	1.65	1230	1.75	1257	1.84	—	—				
2160	1032	1.26	1068	1.36	1102	1.46	1135	1.56	1167	1.66	1198	1.77	1229	1.88	1259	1.98	—	—	—	—				
2400	1061	1.47	1095	1.57	1128	1.67	1161	1.78	1191	1.88	1223	2.00	1254	2.11	1282	2.23	—	—	—	—				
2640	1095	1.70	1126	1.81	1157	1.92	1189	2.03	1219	2.15	1250	2.26	—	—	—	—	—	—	—	—				
2880	1133	1.94	1162	2.06	1191	2.19	1221	2.30	—	—	—	—	—	—	—	—	—	—	—	—				

For Standard Evaporator Fan Speed (RPM), reference [Table 123](#).

Notes:

Data includes pressure drop due to standard filters and wet coils. No accessories or options are included in pressure drop data.

Refer to [Table 128](#) to determine additional static pressure drop due to other options/accessories.

2-HP Fan Motor Heat (MBH) = 3.000 x Fan BHP + .5000.

Factory supplied motors, in commercial equipment, are definite purpose motors, specifically designed and tested to operate reliably and continuously at all cataloged conditions. Using the full horsepower range of our fan motors as shown in our tabular data will not result in nuisance tripping or premature motor failure. Our product's warranty will not be affected.

<sup>(1)</sup> Field Supplied Fan Sheave AK84 and Belt AX34 required.

## Performance Data

*(7½ Tons Standard Efficiency)*

**Table 59. Belt Drive Evaporator Fan Performance 7½ Tons with Electric Heat TSC090,092A3,4,W,K Downflow Airflow**

External Static Pressure (Inches of Water)																					
CFM	.10		.20		.30		.40		.50		.60		.70		.80		.90		1.00		
	RPM	BHP	RPM	BHP	RPM	BHP	RPM	BHP	RPM	BHP	RPM	BHP	RPM	BHP	RPM	BHP	RPM	BHP	RPM	BHP	
<b>2-HP Standard Motor &amp; Field Supplied Low Static Drive<sup>(i)</sup></b>											<b>2-HP Standard Motor &amp; Drive</b>										
2400	—	—	—	—	652	0.54	701	0.63	750	0.72	794	0.81	834	0.90	873	0.98	909	1.08	945	1.17	
2700	—	—	652	0.63	699	0.70	743	0.79	787	0.89	830	0.99	871	1.09	908	1.19	943	1.29	977	1.39	
3000	656	0.71	703	0.81	747	0.91	789	0.99	827	1.10	867	1.20	906	1.31	944	1.43	980	1.54	1013	1.65	
3300	713	0.93	755	1.03	797	1.15	836	1.24	873	1.34	908	1.45	944	1.57	980	1.69	1016	1.82	1050	1.94	
3600	771	1.19	809	1.29	848	1.42	885	1.53	921	1.63	954	1.74	986	1.87	1019	1.99	1052	2.13	1085	2.26	

Continued

External Static Pressure (Inches of Water)																					
CFM	1.10		1.20		1.30		1.40		1.50		1.60		1.70		1.80		1.90		2.00		
	RPM	BHP	RPM	BHP	RPM	BHP	RPM	BHP	RPM	BHP	RPM	BHP	RPM	BHP	RPM	BHP	RPM	BHP	RPM	BHP	
<b>2-HP Standard Motor &amp; Drive</b>							<b>2-HP Standard Motor &amp; High Static Drive Kit (or 3-HP Oversized Motor &amp; Drive)</b>														
2400	980	1.27	1013	1.37	1046	1.47	1076	1.57	1106	1.68	1137	1.78	1166	1.89	1194	1.99	1220	2.08	1248	2.19	
2700	1010	1.49	1043	1.60	1074	1.71	1105	1.82	1134	1.93	1163	2.04	1192	2.16	1219	2.27	1246	2.39	1273	2.51	
3000	1045	1.76	1076	1.87	1105	1.98	1134	2.09	1163	2.21	1192	2.34	1219	2.45	1247	2.58	1272	2.71	1299	2.84	
3300	1081	2.06	1111	2.18	1141	2.30	1168	2.42	1197	2.55	1222	2.66	1249	2.79	1276	2.92	1301	3.06	1326	3.19	
3600	1116	2.39	1148	2.53	1177	2.66	1204	2.79	1232	2.93	1257	3.05	1283	3.19	1309	3.32	—	—	—	—	

**3-HP Oversized Motor & Drive**

For Standard Evaporator Fan Speed (RPM), reference [Table 123](#).

Notes:

Data includes pressure drop due to standard filters and wet coils. No accessories or options are included in pressure drop data.

Refer to [Table 128](#) to determine additional static pressure drop due to other options/accessories.

2-HP Fan Motor Heat (MBH) = 2.000 x Fan BHP + .5000. 3-HP Fan Motor Heat (MBH) = 2.900 x Fan BHP + .4750.

Factory supplied motors, in commercial equipment, are definite purpose motors, specifically designed and tested to operate reliably and continuously at all cataloged conditions. Using the full horsepower range of our fan motors as shown in our tabular data will not result in nuisance tripping or premature motor failure. Our product's warranty will not be affected.

<sup>(i)</sup> Field Supplied Motor Sheave 1VL40L x 7/8 and Fan Sheave AK71 required.

**Table 60. Belt Drive Evaporator Fan Performance 7½ Tons with Electric Heat TSC090,092A3,4,W,K Horizontal Airflow**

External Static Pressure (Inches of Water)																					
CFM	.10		.20		.30		.40		.50		.60		.70		.80		.90		1.00		
	RPM	BHP	RPM	BHP	RPM	BHP	RPM	BHP	RPM	BHP	RPM	BHP	RPM	BHP	RPM	BHP	RPM	BHP	RPM	BHP	
<b>2-HP Standard Motor &amp; Field Supplied Low Static Drive<sup>(i)</sup></b>											<b>2-HP Standard Motor &amp; Drive</b>										
2400	—	—	673	0.56	718	0.63	769	0.72	814	0.82	855	0.90	893	0.98	929	1.08	965	1.18	999	1.29	
2700	702	0.68	738	0.76	773	0.83	817	0.92	862	1.02	904	1.13	941	1.23	975	1.32	1009	1.42	1041	1.52	
3000	771	0.91	805	1.00	837	1.08	870	1.17	912	1.26	951	1.38	989	1.51	1025	1.62	1056	1.72	1088	1.82	
3300	842	1.19	873	1.29	903	1.38	930	1.47	963	1.57	1000	1.68	1037	1.80	1073	1.94	1106	2.08	1136	2.19 <sup>(ii)</sup>	
3600	913	1.53	942	1.63	970	1.74	996	1.84	1021	1.94	1052	2.04	1086	2.16	1121	2.29	1153	2.44	1184	2.59	

**2-HP Standard Motor & High Static Drive Kit (or 3-HP Oversized Motor)**

**3-HP Oversized Motor & Drive**

Continued

External Static Pressure (Inches of Water)																					
CFM	1.10		1.20		1.30		1.40		1.50		1.60		1.70		1.80		1.90		2.00		
	RPM	BHP	RPM	BHP	RPM	BHP	RPM	BHP	RPM	BHP	RPM	BHP	RPM	BHP	RPM	BHP	RPM	BHP	RPM	BHP	
<b>2-HP Standard Motor &amp; Drive</b>							<b>2-HP Standard Motor &amp; High Static Drive Kit (or 3-HP Oversized Motor &amp; Drive)</b>														
2400	1035	1.39	1070	1.50	1104	1.60	1137	1.70	1168	1.81	1201	1.92	1232	2.03	1261	2.14	1291	2.26	1319	2.38	
2700	1073	1.64	1104	1.76	1136	1.87	1167	1.99	1198	2.11	1228	2.22	1258	2.34	1287	2.46	1315	2.58	1343	2.69	
3000	1117	1.93	1146	2.05	1176	2.17	1205	2.31	1233	2.44	1261	2.56	1289	2.69	1317	2.82	1344	2.95	1372	3.08	
3300	1165	2.30	1194	2.41	1220	2.52	1248	2.66	1275	2.79	1301	2.93	1326	3.07	1352	3.22	1378	3.36	—	—	
3600	1215	2.73	1242	2.86	1269	2.98	1295	3.10	1319	3.22	1345	3.35	—	—	—	—	—	—	—	—	

**3-HP Oversized Motor & Drive**

For Standard Evaporator Fan Speed (RPM), reference [Table 123](#).

Notes:

Data includes pressure drop due to standard filters and wet coils. No accessories or options are included in pressure drop data.

Refer to [Table 128](#) to determine additional static pressure drop due to other options/accessories.

2-HP Fan Motor Heat (MBH) = 2.000 x Fan BHP + .5000. 3-HP Fan Motor Heat (MBH) = 2.900 x Fan BHP + .4750.

Factory supplied motors, in commercial equipment, are definite purpose motors, specifically designed and tested to operate reliably and continuously at all cataloged conditions. Using the full horsepower range of our fan motors as shown in our tabular data will not result in nuisance tripping or premature motor failure. Our product's warranty will not be affected.

<sup>(i)</sup> Field Supplied Motor Sheave 1VL40L x 7/8 and Fan Sheave AK71 required.

<sup>(ii)</sup> 2-HP Standard Motor & High Static Drive Kit (or 3-HP Oversized Motor).

## Performance Data

*(7½ Tons Standard Efficiency)*

**Table 61. Belt Drive Evaporator Fan Performance 7½ Tons with Gas Heat YSC090,092A3,4,W,K\*L Low Heat Downflow Airflow**

External Static Pressure (Inches of Water)																					
		.10		.20		.30		.40		.50		.60		.70		.80		.90		1.00	
CFM	RPM	BHP	RPM	BHP	RPM	BHP	RPM	BHP	RPM	BHP	RPM	BHP	RPM	BHP	RPM	BHP	RPM	BHP	RPM	BHP	
<b>2-HP Standard Motor &amp; Field Supplied Low Static Drive<sup>(i)</sup></b>											<b>2-HP Standard Motor &amp; Drive</b>										
2400	—	—	—	—	676	0.59	726	0.67	773	0.77	815	0.85	854	0.94	891	1.03	928	1.12	963	1.22	
2700	—	—	682	0.68	727	0.76	770	0.85	814	0.95	856	1.06	895	1.16	931	1.25	965	1.35	998	1.45	
3000	693	0.79	738	0.89	780	0.97	819	1.07	858	1.18	898	1.29	936	1.40	972	1.52	1006	1.63	1038	1.73	
3300	753	1.03	795	1.14	834	1.23	871	1.33	906	1.45	942	1.56	978	1.69	1014	1.81	1048	1.94	1080	2.06	
3600	814	1.31	853	1.44	890	1.55	925	1.65	958	1.76	991	1.88	1023	2.01	1057	2.14	1088	2.28	1121	2.41	
																			<b>3-HP Oversized Motor</b>		

Continued

External Static Pressure (Inches of Water)																					
		1.10		1.20		1.30		1.40		1.50		1.60		1.70		1.80		1.90		2.00	
CFM	RPM	BHP	RPM	BHP	RPM	BHP	RPM	BHP	RPM	BHP	RPM	BHP	RPM	BHP	RPM	BHP	RPM	BHP	RPM	BHP	
<b>2-HP Standard Motor &amp; Drive</b>								<b>2-HP Standard Motor &amp; High Static Drive Kit (or 3-HP Oversized Motor &amp; Drive)</b>													
2400	996	1.32	1028	1.42	1061	1.52	1092	1.63	1122	1.73	1151	1.83	1180	1.93	1207	2.03	1235	2.14	1261	2.24	
2700	1031	1.56	1062	1.66	1093	1.78	1123	1.89	1153	2.00	1181	2.12	1209	2.23	1236	2.35	1262	2.47	1288	2.58	
3000	1070	1.85	1099	1.95	1128	2.07	1158	2.19	1185	2.31	1213	2.43	1240	2.55	1267	2.68	1293	2.81	1319	2.94	
3300	1110	2.18	1139	2.29	1167	2.42	1195	2.54	1222	2.66	1248	2.79	1274	2.92	1301	3.05	1325	3.18	1351	3.33	
3600	1151	2.55	1181	2.68	1208	2.81	1236	2.95	1261	3.07	1287	3.21	1311	3.33	—	—	—	—	—	—	
<b>3-HP Oversized Motor &amp; Drive</b>																					

For Standard Evaporator Fan Speed (RPM), reference [Table 123](#).

Notes: Data includes pressure drop due to standard filters and wet coils. No accessories or options are included in pressure drop data.

Refer to [Table 128](#) to determine additional static pressure drop due to other options/accessories.

2-HP Fan Motor Heat (MBH) = 2.000 x Fan BHP+.5000. 3-HP Fan Motor Heat (MBH) = 2.900 x Fan BHP+.4750

Factory supplied motors, in commercial equipment, are definite purpose motors, specifically designed and tested to operate reliably and continuously at all cataloged conditions. Using the full horsepower range of our fan motors as shown in our tabular data will not result in nuisance tripping or premature motor failure. Our product's warranty will not be affected.

<sup>(i)</sup> Field Supplied Motor Sheave 1VL40L x 7/8 and Fan Sheave AK71 required.

**Table 62. Belt Drive Evaporator Fan Performance 7½ Tons with Gas Heat YSC090,092A3,4,W\*M Medium Heat Downflow Airflow**

External Static Pressure (Inches of Water)																					
		.10		.20		.30		.40		.50		.60		.70		.80		.90		1.00	
CFM	RPM	BHP	RPM	BHP	RPM	BHP	RPM	BHP	RPM	BHP	RPM	BHP	RPM	BHP	RPM	BHP	RPM	BHP	RPM	BHP	
<b>2-HP Standard Motor &amp; Field Supplied Low Static Drive<sup>(i)</sup></b>											<b>2-HP Standard Motor &amp; Drive</b>										
2400	—	—	662	0.56	711	0.65	759	0.74	802	0.83	842	0.91	879	1.00	916	1.09	951	1.19	986	1.29	
2700	676	0.67	721	0.75	764	0.84	809	0.94	851	1.04	891	1.14	927	1.24	961	1.34	994	1.44	1027	1.54	
3000	741	0.89	783	0.98	822	1.08	861	1.19	901	1.30	939	1.41	975	1.52	1009	1.64	1041	1.74	1071	1.85 <sup>(ii)</sup>	
3300	807	1.17	846	1.26	882	1.37	917	1.48	953	1.60	989	1.72	1024	1.85	1058	1.97	1089	2.09	1119	2.21	
3600	874	1.50	910	1.60	944	1.71	976	1.83	1008	1.95	1041	2.08	1074	2.22	1107	2.35	1138	2.49	1168	2.62	
																			<b>3-HP Oversized Motor &amp; Drive</b>		

Continued

External Static Pressure (Inches of Water)																					
		1.10		1.20		1.30		1.40		1.50		1.60		1.70		1.80		1.90		2.00	
CFM	RPM	BHP	RPM	BHP	RPM	BHP	RPM	BHP	RPM	BHP	RPM	BHP	RPM	BHP	RPM	BHP	RPM	BHP	RPM	BHP	
<b>2-HP Standard Motor &amp; Drive</b>								<b>2-HP Standard Motor &amp; High Static Drive Kit (or 3-HP Oversized Motor &amp; Drive)</b>													
2400	1019	1.39	1051	1.49	1083	1.60	1113	1.70	1141	1.80	1171	1.90	1199	2.01	1225	2.10	1252	2.20	1278	2.31	
2700	1058	1.65	1089	1.76	1120	1.87	1149	1.99	1178	2.10	1205	2.21	1232	2.33	1259	2.45	1284	2.56	1310	2.68	
3000	1101	1.96	1131	2.08	1160	2.20	1187	2.31	1215	2.44	1243	2.57	1269	2.69	1295	2.82	1321	2.95	1346	3.08	
3300	1147	2.33	1176	2.45	1204	2.58	1230	2.70	1256	2.82	1282	2.96	1308	3.09	1333	3.23	1358	3.36	—	—	
3600	1196	2.75	1223	2.88	1250	3.02	1276	3.15	1301	3.28	1325	3.41	—	—	—	—	—	—	—	—	
<b>3-HP Oversized Motor &amp; Drive</b>																					

For Standard Evaporator Fan Speed (RPM), reference [Table 123](#).

Notes: Data includes pressure drop due to standard filters and wet coils. No accessories or options are included in pressure drop data.

Refer to [Table 128](#) to determine additional static pressure drop due to other options/accessories.

2-HP Fan Motor Heat (MBH) = 2.000 x Fan BHP+.5000. 3-HP Fan Motor Heat (MBH) = 2.900 x Fan BHP+.4750.

Factory supplied motors, in commercial equipment, are definite purpose motors, specifically designed and tested to operate reliably and continuously at all cataloged conditions. Using the full horsepower range of our fan motors as shown in our tabular data will not result in nuisance tripping or premature motor failure. Our product's warranty will not be affected.

<sup>(i)</sup> Field Supplied Motor Sheave 1VL40L x 7/8 and Fan Sheave AK71 required.

<sup>(ii)</sup> 2-HP Standard Motor & High Static Drive (or 3-HP Oversized Motor).

## Performance Data

*(7½ Tons Standard Efficiency)*

**Table 63. Belt Drive Evaporator Fan Performance 7½ Tons with Gas Heat YSC090,092A3,4,W,K\*H High Heat Downflow Airflow**

External Static Pressure (Inches of Water)																				
CFM	.10		.20		.30		.40		.50		.60		.70		.80		.90		1.00	
	RPM	BHP	RPM	BHP	RPM	BHP	RPM	BHP	RPM	BHP	RPM	BHP	RPM	BHP	RPM	BHP	RPM	BHP	RPM	BHP
<b>2-HP Standard Motor &amp; Field Supplied Low Static Drive<sup>(i)</sup></b>										<b>2-HP Standard Motor &amp; Drive</b>										
2400	—	—	697	0.62	745	0.71	790	0.80	830	0.89	869	0.98	906	1.07	941	1.16	976	1.26	1009	1.36
2700	717	0.74	760	0.83	804	0.93	847	1.03	887	1.13	922	1.23	958	1.33	991	1.43	1024	1.53	1055	1.64
3000	787	0.99	826	1.09	865	1.20	905	1.31	943	1.42	979	1.54	1012	1.64	1044	1.76	1075	1.87	1105	1.98
3300	858	1.30	894	1.41	929	1.52	965	1.64	1001	1.77	1036	1.89	1068	2.01	1099	2.13	1129	2.25 <sup>(ii)</sup>	1157	2.37
3600	930	1.66	963	1.78	995	1.90	1028	2.03	1061	2.16	1093	2.30	1126	2.43	1157	2.57	1185	2.70	1212	2.83
										<b>3-HP Oversized Motor &amp; Drive</b>										

Continued

External Static Pressure (Inches of Water)																				
CFM	1.10		1.20		1.30		1.40		1.50		1.60		1.70		1.80		1.90		2.00	
	RPM	BHP	RPM	BHP	RPM	BHP	RPM	BHP	RPM	BHP	RPM	BHP	RPM	BHP	RPM	BHP	RPM	BHP	RPM	BHP
<b>2-HP Standard Motor &amp; Drive</b>							<b>2-HP Standard Motor &amp; High Static Drive Kit (or 3-HP Oversized Motor &amp; Drive)</b>													
2400	1042	1.46	1073	1.56	1104	1.67	1134	1.77	1163	1.87	1190	1.97	1218	2.08	1244	2.18	1271	2.28	1296	2.38
2700	1086	1.75	1117	1.86	1146	1.97	1174	2.09	1203	2.21	1230	2.32	1255	2.44	1282	2.55	1308	2.67	1333	2.78
3000	1134	2.09	1163	2.21	1191	2.33	1218	2.45	1245	2.58	1272	2.70	1298	2.83	1323	2.96	1348	3.09	1372	3.22
3300	1185	2.49	1212	2.61	1238	2.74	1265	2.87	1292	3.01	1316	3.13	1341	3.27	1366	3.41	—	—	—	—
3600	1239	2.96	1265	3.09	1290	3.22	1316	3.36	—	—	—	—	—	—	—	—	—	—	—	—
										<b>3-HP Oversized Motor &amp; Drive</b>										

For Standard Evaporator Fan Speed (RPM), reference [Table 123](#).

Notes: Data includes pressure drop due to standard filters and wet coils. No accessories or options are included in pressure drop data.

Refer to [Table 128](#) to determine additional static pressure drop due to other options/accessories.

2-HP Fan Motor Heat (MBH) = 2.000 x Fan BHP + .5000. 3-HP Fan Motor Heat (MBH) = 2.900 x Fan BHP + .4750.

Factory supplied motors, in commercial equipment, are definite purpose motors, specifically designed and tested to operate reliably and continuously at all cataloged conditions. Using the full horsepower range of our fan motors as shown in our tabular data will not result in nuisance tripping or premature motor failure. Our product's warranty will not be affected.

<sup>(i)</sup> Field Supplied Motor Sheave 1VL40L x 7/8 and Fan Sheave AK71 required.

<sup>(ii)</sup> 2-HP Standard Motor & High Static Drive Kit (or 3-HP Oversized Motor)

**Table 64. Belt Drive Evaporator Fan Performance 7½ Tons with Gas Heat YSC090,092A3,4,W,K\*L Low Heat Horizontal Airflow**

External Static Pressure (Inches of Water)																				
CFM	.10		.20		.30		.40		.50		.60		.70		.80		.90		1.00	
	RPM	BHP	RPM	BHP	RPM	BHP	RPM	BHP	RPM	BHP	RPM	BHP	RPM	BHP	RPM	BHP	RPM	BHP	RPM	BHP
<b>2-HP Standard Motor &amp; Field Supplied Low Static Drive<sup>(i)</sup></b>										<b>2-HP Standard Motor &amp; Drive</b>										
2400	653	0.53	694	0.59	745	0.67	793	0.77	835	0.86	874	0.94	911	1.03	948	1.13	982	1.23	1017	1.34
2700	725	0.73	760	0.80	801	0.88	847	0.98	889	1.09	927	1.19	963	1.28	997	1.38	1030	1.48	1061	1.60
3000	798	0.98	830	1.06	862	1.15	902	1.24	943	1.35	981	1.48	1017	1.60	1050	1.70	1081	1.80	1111	1.90
3300	872	1.28	901	1.38	929	1.47	961	1.56	998	1.67	1036	1.80	1071	1.93	1104	2.07	1135	2.19	1164	2.30 <sup>(ii)</sup>
3600	946	1.65	973	1.75	1000	1.85	1025	1.95	1057	2.06	1091	2.17	1125	2.31	1158	2.46	1189	2.61	1219	2.75
										<b>3-HP Oversized Motor &amp; Drive</b>										

Continued

External Static Pressure (Inches of Water)																				
CFM	1.10		1.20		1.30		1.40		1.50		1.60		1.70		1.80		1.90		2.00	
	RPM	BHP	RPM	BHP	RPM	BHP	RPM	BHP	RPM	BHP	RPM	BHP	RPM	BHP	RPM	BHP	RPM	BHP	RPM	BHP
<b>2-HP Standard Motor &amp; Drive</b>							<b>2-HP Standard Motor &amp; High Static Drive Kit (or 3-HP Oversized Motor &amp; Drive)</b>													
2400	1053	1.44	1087	1.55	1121	1.65	1153	1.76	1185	1.86	1217	1.98	1246	2.08	1277	2.20	1306	2.32	1334	2.44
2700	1093	1.71	1124	1.83	1156	1.95	1187	2.06	1218	2.18	1248	2.30	1277	2.42	1306	2.53	1333	2.65	1361	2.78
3000	1141	2.02	1170	2.15	1198	2.28	1227	2.41	1255	2.54	1283	2.67	1311	2.79	1339	2.93	1365	3.05	1391	3.18
3300	1192	2.41	1220	2.52	1247	2.65	1272	2.78	1299	2.92	1325	3.07	1350	3.21	1376	3.36	—	—	—	—
3600	1246	2.87	1272	2.99	1298	3.11	1323	3.24	1348	3.37	—	—	—	—	—	—	—	—	—	—
										<b>3-HP Oversized Motor &amp; Drive</b>										

For Standard Evaporator Fan Speed (RPM), reference [Table 123](#).

Notes: Data includes pressure drop due to standard filters and wet coils. No accessories or options are included in pressure drop data.

Refer to [Table 128](#) to determine additional static pressure drop due to other options/accessories.

2-HP Fan Motor Heat (MBH) = 2.000 x Fan BHP + .5000. 3-HP Fan Motor Heat (MBH) = 2.900 x Fan BHP + .4750.

Factory supplied motors, in commercial equipment, are definite purpose motors, specifically designed and tested to operate reliably and continuously at all cataloged conditions. Using the full horsepower range of our fan motors as shown in our tabular data will not result in nuisance tripping or premature motor failure. Our product's warranty will not be affected.

<sup>(i)</sup> Field Supplied Motor Sheave 1VL40L x 7/8 and Fan Sheave AK71 required.

<sup>(ii)</sup> 2-HP Standard Motor & High Static Drive Kit (or 3-HP Oversized Motor)

## Performance Data

*(7½ Tons Standard Efficiency)*

**Table 65. Belt Drive Evaporator Fan Performance 7½ Tons with Gas Heat YSC090,092A3,4,W\*M Medium Heat Horizontal Airflow**

CFM	External Static Pressure (Inches of Water)																			
	.10		.20		.30		.40		.50		.60		.70		.80		.90		1.00	
	RPM	BHP	RPM	BHP	RPM	BHP	RPM	BHP	RPM	BHP	RPM	BHP	RPM	BHP	RPM	BHP	RPM	BHP	RPM	BHP
<b>2-HP Standard Motor &amp; Field Supplied Low Static Drive<sup>(i)</sup></b>										<b>2-HP Standard Motor &amp; Drive</b>										
2400	680	0.57	729	0.65	778	0.74	823	0.84	862	0.92	900	1.00	936	1.10	972	1.20	1006	1.31	1041	1.41
2700	756	0.79	795	0.87	841	0.97	884	1.08	923	1.18	959	1.27	992	1.36	1025	1.47	1057	1.58	1089	1.70
3000	833	1.07	865	1.16	906	1.25	946	1.36	985	1.49	1020	1.61	1052	1.71	1083	1.81	1114	1.91	1143	2.03 <sup>(ii)</sup>
3300	910	1.41	938	1.50	972	1.60	1010	1.70	1047	1.84	1081	1.97	1114	2.11	1144	2.22	1173	2.33	1200	2.44
3600	988	1.81	1014	1.91	1042	2.01	1076	2.12	1110	2.25	1143	2.39	1175	2.54	1205	2.69	1234	2.82	1260	2.94
										<b>3-HP Oversized Motor &amp; Drive</b>										

Continued

CFM	External Static Pressure (Inches of Water)																			
	1.10		1.20		1.30		1.40		1.50		1.60		1.70		1.80		1.90		2.00	
	RPM	BHP	RPM	BHP	RPM	BHP	RPM	BHP	RPM	BHP	RPM	BHP	RPM	BHP	RPM	BHP	RPM	BHP	RPM	BHP
<b>2-HP Standard Motor &amp; Drive</b>										<b>2-HP Standard Motor &amp; High Static Drive Kit (or 3-HP Oversized Motor &amp; Drive)</b>										
2400	1076	1.51	1110	1.62	1143	1.72	1176	1.83	1206	1.94	1238	2.05	1267	2.16	1297	2.28	1325	2.40	1353	2.52
2700	1120	1.82	1152	1.93	1183	2.05	1214	2.17	1243	2.28	1273	2.40	1302	2.52	1330	2.64	1357	2.76	1385	2.89
3000	1172	2.15	1201	2.29	1229	2.42	1257	2.55	1285	2.68	1312	2.80	1340	2.93	1367	3.06	1395	3.19	1421	3.33
3300	1227	2.56	1255	2.69	1281	2.83	1307	2.97	1333	3.11	1359	3.26	1384	3.40	—	—	—	—	—	—
3600	1287	3.06	1312	3.18	1337	3.31	1361	3.45	—	—	—	—	—	—	—	—	—	—	—	—
										<b>3-HP Oversized Motor &amp; Drive</b>										

For Standard Evaporator Fan Speed (RPM), reference [Table 123](#).

Notes: Data includes pressure drop due to standard filters and wet coils. No accessories or options are included in pressure drop data.

Refer to [Table 128](#) to determine additional static pressure drop due to other options/accessories.

2-HP Fan Motor Heat (MBH) = 2.000 x Fan BHP + .5000. 3-HP Fan Motor Heat (MBH) = 2.900 x Fan BHP + .4750.

Factory supplied motors, in commercial equipment, are definite purpose motors, specifically designed and tested to operate reliably and continuously at all cataloged conditions. Using the full horsepower range of our fan motors as shown in our tabular data will not result in nuisance tripping or premature motor failure. Our product's warranty will not be affected.

<sup>(i)</sup> Field Supplied Motor Sheave 1VL40L x 7/8 and Fan Sheave AK71 required.

<sup>(ii)</sup> 2-HP Standard Motor & High Static Drive Kit (or 3-HP Oversized Motor)

**Table 66. Belt Drive Evaporator Fan Performance 7½ Tons with Gas Heat YSC090,092A3,4,W,K\*H High Heat Horizontal Airflow**

CFM	External Static Pressure (Inches of Water)																			
	.10		.20		.30		.40		.50		.60		.70		.80		.90		1.00	
	RPM	BHP	RPM	BHP	RPM	BHP	RPM	BHP	RPM	BHP	RPM	BHP	RPM	BHP	RPM	BHP	RPM	BHP	RPM	BHP
<b>2-HP Standard Motor &amp; Field Supplied Low Static Drive<sup>(i)</sup></b>										<b>2-HP Standard Motor &amp; Drive</b>										
2400	713	0.62	764	0.71	811	0.81	851	0.89	889	0.97	926	1.07	962	1.17	997	1.28	1031	1.38	1067	1.48
2700	790	0.86	837	0.96	880	1.07	919	1.17	955	1.26	989	1.36	1022	1.46	1054	1.57	1086	1.69	1117 <sup>(ii)</sup>	1.80
3000	869	1.16	910	1.26	950	1.38	989	1.50	1023	1.62	1056	1.72	1086	1.82	1116	1.92	1146	2.04	1175	2.17
3300	949	1.53	985	1.63	1023	1.75	1058	1.88	1092	2.02	1124	2.15	1154	2.26	1182	2.37	1210	2.48	1237	2.60
3600	1029	1.97	1061	2.07	1096	2.19	1130	2.33	1162	2.48	1193	2.63	1222	2.77	1250	2.89	1276	3.01	1302	3.13
										<b>3-HP Oversized Motor &amp; Drive</b>										

Continued

CFM	External Static Pressure (Inches of Water)																			
	1.10		1.20		1.30		1.40		1.50		1.60		1.70		1.80		1.90		2.00	
	RPM	BHP	RPM	BHP	RPM	BHP	RPM	BHP	RPM	BHP	RPM	BHP	RPM	BHP	RPM	BHP	RPM	BHP	RPM	BHP
<b>2-HP Standard Motor &amp; Drive</b>										<b>2-HP Standard Motor &amp; High Static Drive Kit (or 3-HP Oversized Motor &amp; Drive)</b>										
2400	1101	1.59	1134	1.69	1166	1.80	1197	1.90	1229	2.02	1259	2.13	1287	2.25	1317	2.37	1344	2.48	1373	2.61
2700	1148	1.92	1180	2.04	1210	2.15	1241	2.27	1269	2.39	1299	2.51	1326	2.62	1354	2.74	1383	2.88	1409	3.00
3000	1204	2.30	1232	2.43	1260	2.56	1287	2.69	1316	2.82	1344	2.95	1370	3.07	1397	3.20	1423	3.34	—	—
3300	1264	2.74	1290	2.87	1316	3.02	1342	3.16	1367	3.30	1393	3.45	—	—	—	—	—	—	—	—
3600	1327	3.26	1352	3.39	—	—	—	—	—	—	—	—	—	—	—	—	—	—	—	—
										<b>3-HP Oversized Motor &amp; Drive</b>										

For Standard Evaporator Fan Speed (RPM), reference [Table 123](#).

Notes: Data includes pressure drop due to standard filters and wet coils. No accessories or options are included in pressure drop data.

Refer to [Table 128](#) to determine additional static pressure drop due to other options/accessories.

2-HP Fan Motor Heat (MBH) = 2.000 x Fan BHP + .5000. 3-HP Fan Motor Heat (MBH) = 2.900 x Fan BHP + .4750.

Factory supplied motors, in commercial equipment, are definite purpose motors, specifically designed and tested to operate reliably and continuously at all cataloged conditions. Using the full horsepower range of our fan motors as shown in our tabular data will not result in nuisance tripping or premature motor failure. Our product's warranty will not be affected.

<sup>(i)</sup> Field Supplied Motor Sheave 1VL40L x 7/8 and Fan Sheave AK71 required.

<sup>(ii)</sup> 2-HP Standard Motor & High Static Drive Kit (or 3-HP Oversized Motor)

**Performance Data**

*(8½ Tons Standard Efficiency)*

**Table 67. Belt Drive Evaporator Fan Performance 8½ Tons with Electric Heat TSC102A3,4,W,K Downflow Airflow**

CFM	External Static Pressure (Inches of Water)																				
	.10		.20		.30		.40		.50		.60		.70		.80		.90		1.00		
	RPM	BHP	RPM	BHP	RPM	BHP	RPM	BHP	RPM	BHP	RPM	BHP	RPM	BHP	RPM	BHP	RPM	BHP	RPM	BHP	
<b>2-HP Standard Motor &amp; Field Supplied Low Static Drive<sup>(1)</sup></b>																					
2720	—	—	—	—	—	—	613	0.60	655	0.72	695	0.84	733	0.95	769	1.08	802	1.21	833	1.34	
3060	—	—	—	—	611	0.64	650	0.74	688	0.85	725	0.98	761	1.11	796	1.25	828	1.38	861	1.52	
3400	—	—	612	0.68	651	0.79	689	0.91	724	1.02	759	1.15	792	1.29	825	1.43	856	1.58	887	1.72	
3740	622	0.76	659	0.86	693	0.97	729	1.10	764	1.23	795	1.35	826	1.49	857	1.64	887	1.79	916	1.96	
4080	671	0.96	706	1.08	738	1.19	770	1.32	804	1.46	834	1.60	864	1.74	892	1.88	920	2.04	948	2.20	
<b>2-HP Standard Motor &amp; Drive</b>																					

Continued

CFM	External Static Pressure (Inches of Water)																				
	1.10		1.20		1.30		1.40		1.50		1.60		1.70		1.80		1.90		2.00		
	RPM	BHP	RPM	BHP	RPM	BHP	RPM	BHP	RPM	BHP	RPM	BHP	RPM	BHP	RPM	BHP	RPM	BHP	RPM	BHP	
<b>2-HP Standard Motor &amp; Drive</b>											<b>3-HP Oversized Motor &amp; Drive</b>										
2720	863	1.48	892	1.63	920	1.78	946	1.93	973	2.08	999	2.24	1025	2.39	1050	2.55	1073	2.71	1098	2.88	
3060	891	1.66	919	1.81	946	1.96	973	2.12	999	2.29	1024	2.46	1048	2.63	1072	2.80	1096	2.98	1119	3.14	
3400	917	1.87	946	2.03	974	2.18	1001	2.34	1026	2.52	1051	2.69	1074	2.86	1099	3.05	1121	3.23	1143	3.41	
3740	945	2.11	974	2.28	1001	2.44	1028	2.61	1054	2.78	1079	2.96	1103	3.14	1126	3.32	—	—	—	—	
4080	976	2.38	1002	2.56	1029	2.73	1055	2.91	1081	3.09	1105	3.26	1130	3.45	—	—	—	—	—	—	

For Standard Evaporator Fan Speed (RPM), reference [Table 123](#).

Notes:

Data includes pressure drop due to standard filters and wet coils. No accessories or options are included in pressure drop data.

Refer to [Table 128](#) to determine additional static pressure drop due to other options/accessories.

2-HP Fan Motor Heat (MBH) = 2.000 x Fan BHP+.5000. 3-HP Fan Motor Heat (MBH) = 2.900 x Fan BHP+.4750.

Factory supplied motors, in commercial equipment, are definite purpose motors, specifically designed and tested to operate reliably and continuously at all cataloged conditions. Using the full horsepower range of our fan motors as shown in our tabular data will not result in nuisance tripping or premature motor failure. Our product's warranty will not be affected.

<sup>(1)</sup> Field Supplied Fan Sheave AK79 and Belt AX38 required.

**Table 68. Belt Drive Evaporator Fan Performance 8½ Tons with Electric Heat TSC102A3,4,W,K Horizontal Airflow**

CFM	External Static Pressure (Inches of Water)																				
	.10		.20		.30		.40		.50		.60		.70		.80		.90		1.00		
	RPM	BHP	RPM	BHP	RPM	BHP	RPM	BHP	RPM	BHP	RPM	BHP	RPM	BHP	RPM	BHP	RPM	BHP	RPM	BHP	
<b>2-HP Standard Motor &amp; Field Supplied Low Static Drive<sup>(1)</sup></b>											<b>2-HP Standard Motor &amp; Drive</b>										
2720	—	—	598	0.57	646	0.67	689	0.78	734	0.90	781	1.04	826	1.18	865	1.31	898	1.44	928	1.56	
3060	616	0.69	654	0.77	693	0.86	735	0.98	773	1.10	812	1.23	855	1.39	897	1.55	934	1.70	969	1.85	
3400	675	0.92	711	1.01	743	1.10	781	1.22	819	1.36	853	1.49	886	1.62	925	1.79	964	1.97	1000	2.14	
3740	735	1.20	770	1.30	799	1.40	830	1.51	865	1.65	899	1.79	930	1.94	960	2.09	994	2.26	1028	2.44	
4080	796	1.53	828	1.65	857	1.76	883	1.86	913	1.99	945	2.15	977	2.30	1006	2.47	1034	2.63	1061	2.79	
<b>3-HP Standard Motor &amp; Drive</b>																					

Continued

CFM	External Static Pressure (Inches of Water)																				
	1.10		1.20		1.30		1.40		1.50		1.60		1.70		1.80		1.90		2.00		
	RPM	BHP	RPM	BHP	RPM	BHP	RPM	BHP	RPM	BHP	RPM	BHP	RPM	BHP	RPM	BHP	RPM	BHP	RPM	BHP	
<b>2-HP Standard Motor &amp; Drive</b>											<b>3-HP Oversized Motor &amp; Drive</b>										
2720	956	1.67	982	1.79	1008	1.91	1033	2.03	1056	2.14	1079	2.26	1102	2.38	1125	2.50	1146	2.62	1168	2.74	
3060	999	1.99	1026	2.12	1052	2.26	1078	2.39	1101	2.52	1124	2.66	1146	2.79	1168	2.92	1188	3.05	1209	3.18	
3400	1034	2.32	1067	2.49	1094	2.64	1120	2.79	1145	2.94	1168	3.09	1191	3.24	1213	3.39	—	—	—	—	
3740	1063	2.63	1098	2.84	1129	3.03	1158	3.21	1185	3.39	—	—	—	—	—	—	—	—	—	—	
4080	1093	2.99	1125	3.19	1157	3.40	—	—	—	—	—	—	—	—	—	—	—	—	—	—	

For Standard Evaporator Fan Speed (RPM), reference [Table 123](#).

Notes:

Data includes pressure drop due to standard filters and wet coils. No accessories or options are included in pressure drop data.

Refer to [Table 128](#) to determine additional static pressure drop due to other options/accessories.

2-HP Fan Motor Heat (MBH) = 2.000 x Fan BHP+.5000. 3-HP Fan Motor Heat (MBH) = 2.900 x Fan BHP+.4750.

Factory supplied motors, in commercial equipment, are definite purpose motors, specifically designed and tested to operate reliably and continuously at all cataloged conditions. Using the full horsepower range of our fan motors as shown in our tabular data will not result in nuisance tripping or premature motor failure. Our product's warranty will not be affected.

<sup>(1)</sup> Field Supplied Fan Sheave AK79 and Belt AX38 required.



## Performance Data

*(8½ Tons Standard Efficiency)*

**Table 69. Belt Drive Evaporator Fan Performance 8½ Tons with Gas Heat YSC102A3,4,W,K\*L,M Low & Medium Heat Downflow Airflow**

External Static Pressure (Inches of Water)																					
		.10		.20		.30		.40		.50		.60		.70		.80		.90		1.00	
CFM	RPM	BHP	RPM	BHP	RPM	BHP	RPM	BHP	RPM	BHP	RPM	BHP	RPM	BHP	RPM	BHP	RPM	BHP	RPM	BHP	
<b>2-HP Standard Motor &amp; Field Supplied Low Static Drive<sup>(1)</sup></b>										<b>2-HP Standard Motor &amp; Drive</b>											
2720	—	—	—	—	608	0.59	649	0.70	689	0.82	728	0.94	764	1.06	798	1.19	829	1.33	859	1.46	
3060	—	—	615	0.65	654	0.75	692	0.87	728	0.99	764	1.13	799	1.26	833	1.39	864	1.53	894	1.68	
3400	625	0.72	665	0.83	702	0.95	736	1.06	770	1.19	804	1.34	836	1.49	868	1.63	899	1.78	928	1.93	
3740	681	0.93	716	1.05	752	1.18	784	1.31	815	1.44	846	1.58	876	1.74	906	1.90	935	2.06	963	2.22	
4080	737	1.19	769	1.31	802	1.45	833	1.60	862	1.73	891	1.87	919	2.03	947	2.20	974	2.37	1001	2.55	

Continued

External Static Pressure (Inches of Water)																					
		1.10		1.20		1.30		1.40		1.50		1.60		1.70		1.80		1.90		2.00	
CFM	RPM	BHP	RPM	BHP	RPM	BHP	RPM	BHP	RPM	BHP	RPM	BHP	RPM	BHP	RPM	BHP	RPM	BHP	RPM	BHP	
<b>2-HP Standard Motor &amp; Drive</b>										<b>3-HP Oversized Motor &amp; Drive</b>											
2720	888	1.61	916	1.76	943	1.91	970	2.07	996	2.22	1021	2.37	1046	2.53	1071	2.69	1096	2.86	1119	3.02	
3060	922	1.82	949	1.98	976	2.14	1001	2.31	1026	2.47	1051	2.65	1074	2.81	1098	2.99	1120	3.16	1144	3.34	
3400	957	2.08	984	2.24	1011	2.41	1035	2.58	1060	2.75	1083	2.93	1106	3.11	1128	3.29	—	—	—	—	
3740	992	2.39	1018	2.55	1045	2.72	1070	2.90	1095	3.08	1117	3.25	1140	3.44	—	—	—	—	—	—	
4080	1028	2.73	1053	2.90	1079	3.07	1104	3.26	1128	3.44	—	—	—	—	—	—	—	—	—	—	

For Standard Evaporator Fan Speed (RPM), reference [Table 123](#).

Notes:

Data includes pressure drop due to standard filters and wet coils. No accessories or options are included in pressure drop data.

Refer to [Table 128](#) to determine additional static pressure drop due to other options/accessories.

2-HP Fan Motor Heat (MBH) = 2.000 x Fan BHP+.5000. 3-HP Fan Motor Heat (MBH) = 2.900 x Fan BHP+.4750.

Factory supplied motors, in commercial equipment, are definite purpose motors, specifically designed and tested to operate reliably and continuously at all cataloged conditions. Using the full horsepower range of our fan motors as shown in our tabular data will not result in nuisance tripping or premature motor failure. Our product's warranty will not be affected.

<sup>(1)</sup> Field Supplied Fan Sheave AK79 and Belt AX38 required.

**Table 70. Belt Drive Evaporator Fan Performance 8½ Tons with Gas Heat YSC102A3,4,W,K\*H High Heat Downflow Airflow**

External Static Pressure (Inches of Water)																					
		.10		.20		.30		.40		.50		.60		.70		.80		.90		1.00	
CFM	RPM	BHP	RPM	BHP	RPM	BHP	RPM	BHP	RPM	BHP	RPM	BHP	RPM	BHP	RPM	BHP	RPM	BHP	RPM	BHP	
<b>2-HP Standard Motor &amp; Field Supplied Low Static Drive<sup>(1)</sup></b>										<b>2-HP Standard Motor &amp; Drive</b>											
2720	—	—	—	—	619	0.62	661	0.74	700	0.85	738	0.97	773	1.09	807	1.23	838	1.36	868	1.51	
3060	586	0.58	629	0.68	667	0.79	705	0.91	741	1.04	776	1.17	810	1.30	843	1.44	874	1.58	904	1.72	
3400	642	0.76	681	0.88	717	1.00	751	1.12	785	1.25	817	1.40	849	1.55	881	1.69	911	1.84	940	1.99	
3740	698	0.99	735	1.12	769	1.25	800	1.37	831	1.51	862	1.66	892	1.82	920	1.98	950	2.14	977	2.30	
4080	756	1.26	789	1.40	821	1.54	851	1.68	879	1.82	908	1.97	936	2.13	964	2.30	991	2.48	1017	2.66	

Continued

External Static Pressure (Inches of Water)																					
		1.10		1.20		1.30		1.40		1.50		1.60		1.70		1.80		1.90		2.00	
CFM	RPM	BHP	RPM	BHP	RPM	BHP	RPM	BHP	RPM	BHP	RPM	BHP	RPM	BHP	RPM	BHP	RPM	BHP	RPM	BHP	
<b>2-HP Standard Motor &amp; Drive</b>										<b>3-HP Oversized Motor &amp; Drive</b>											
2720	896	1.65	923	1.80	950	1.95	977	2.11	1003	2.26	1029	2.42	1053	2.57	1078	2.74	1102	2.90	1124	3.06	
3060	932	1.88	959	2.04	985	2.20	1010	2.36	1034	2.53	1058	2.70	1082	2.87	1105	3.05	1129	3.22	1151	3.39	
3400	969	2.15	996	2.31	1020	2.48	1045	2.65	1070	2.83	1093	3.00	1116	3.19	1138	3.37	—	—	—	—	
3740	1005	2.47	1032	2.64	1058	2.81	1083	2.99	1106	3.16	1129	3.35	—	—	—	—	—	—	—	—	
4080	1044	2.83	1069	3.01	1095	3.19	1119	3.37	—	—	—	—	—	—	—	—	—	—	—	—	

For Standard Evaporator Fan Speed (RPM), reference [Table 123](#).

Notes:

Data includes pressure drop due to standard filters and wet coils. No accessories or options are included in pressure drop data.

Refer to [Table 128](#) to determine additional static pressure drop due to other options/accessories.

2-HP Fan Motor Heat (MBH) = 2.000 x Fan BHP+.5000. 3-HP Fan Motor Heat (MBH) = 2.900 x Fan BHP+.4750.

Factory supplied motors, in commercial equipment, are definite purpose motors, specifically designed and tested to operate reliably and continuously at all cataloged conditions. Using the full horsepower range of our fan motors as shown in our tabular data will not result in nuisance tripping or premature motor failure. Our product's warranty will not be affected.

<sup>(1)</sup> Field Supplied Fan Sheave AK79 and Belt AX38 required.

**Performance Data**

*(8½ Tons Standard Efficiency)*

**Table 71. Belt Drive Evaporator Fan Performance 8½ Tons with Gas Heat YSC102A3,4,W,K\*L,M Low & Medium Heat Horizontal Airflow**

External Static Pressure (Inches of Water)																					
		.10		.20		.30		.40		.50		.60		.70		.80		.90		1.00	
CFM	RPM	BHP	RPM	BHP	RPM	BHP	RPM	BHP	RPM	BHP	RPM	BHP	RPM	BHP	RPM	BHP	RPM	BHP	RPM	BHP	
<b>2-HP Standard Motor &amp; Field Supplied Low Static Drive<sup>(1)</sup></b>										<b>2-HP Standard Motor &amp; Drive</b>											
2720	607	0.59	655	0.69	697	0.80	744	0.93	791	1.07	834	1.21	871	1.34	904	1.46	933	1.58	962	1.70	
3060	672	0.81	715	0.92	755	1.04	792	1.16	834	1.31	876	1.47	917	1.63	953	1.78	985	1.93	1013	2.06	
3400	739	1.09	776	1.20	814	1.34	849	1.47	882	1.61	920	1.77	958	1.94	996	2.12	1030	2.29	1063	2.47	
3740	807	1.43	839	1.54	875	1.69	907	1.83	938	1.98	969	2.13	1003	2.30	1037	2.49	1072	2.69	1106	2.88	
4080	875	1.83	903	1.95	935	2.10	968	2.26	997	2.42	1025	2.58	1053	2.74	1084	2.93	1116	3.13	1148	3.34	
										<b>3-HP Oversized Motor &amp; Drive</b>											

Continued

External Static Pressure (Inches of Water)																					
		1.10		1.20		1.30		1.40		1.50		1.60		1.70		1.80		1.90		2.00	
CFM	RPM	BHP	RPM	BHP	RPM	BHP	RPM	BHP	RPM	BHP	RPM	BHP	RPM	BHP	RPM	BHP	RPM	BHP	RPM	BHP	
<b>2-HP Standard Motor &amp; Drive</b>										<b>3-HP Oversized Motor &amp; Drive</b>											
2720	988	1.81	1013	1.93	1037	2.05	1061	2.17	1084	2.28	1106	2.40	1128	2.52	1150	2.64	1172	2.76	1192	2.88	
3060	1040	2.19	1065	2.33	1090	2.46	1113	2.59	1136	2.72	1158	2.86	1179	2.99	1199	3.12	1220	3.25	1239	3.38	
3400	1091	2.62	1117	2.78	1141	2.92	1165	3.07	1188	3.22	1210	3.37	—	—	—	—	—	—	—	—	
3740	1137	3.07	1166	3.27	1193	3.44	—	—	—	—	—	—	—	—	—	—	—	—	—	—	
4080	—	—	—	—	—	—	—	—	—	—	—	—	—	—	—	—	—	—	—	—	

For Standard Evaporator Fan Speed (RPM), reference [Table 123](#).

Notes:

Data includes pressure drop due to standard filters and wet coils. No accessories or options are included in pressure drop data.

Refer to [Table 128](#) to determine additional static pressure drop due to other options/accessories.

2-HP Fan Motor Heat (MBH) = 2.000 x Fan BHP+.5000. 3-HP Fan Motor Heat (MBH) = 2.900 x Fan BHP+.4750.

Factory supplied motors, in commercial equipment, are definite purpose motors, specifically designed and tested to operate reliably and continuously at all cataloged conditions. Using the full horsepower range of our fan motors as shown in our tabular data will not result in nuisance tripping or premature motor failure. Our product's warranty will not be affected.

<sup>(1)</sup> Field Supplied Fan Sheave AK79 and Belt AX38 required.

**Table 72. Belt Drive Evaporator Fan Performance 8½ Tons with Gas Heat YSC102A3,4,W,K\*H High Heat Horizontal Airflow**

External Static Pressure (Inches of Water)																					
		.10		.20		.30		.40		.50		.60		.70		.80		.90		1.00	
CFM	RPM	BHP	RPM	BHP	RPM	BHP	RPM	BHP	RPM	BHP	RPM	BHP	RPM	BHP	RPM	BHP	RPM	BHP	RPM	BHP	
<b>2-HP Standard Motor &amp; Field Supplied Low Static Drive<sup>(1)</sup></b>										<b>2-HP Standard Motor &amp; Drive</b>											
2720	625	0.63	671	0.73	713	0.84	762	0.98	807	1.12	849	1.26	883	1.38	915	1.50	944	1.62	971	1.74	
3060	692	0.86	734	0.98	772	1.10	811	1.23	854	1.38	896	1.54	934	1.70	969	1.85	997	1.99	1026	2.12	
3400	760	1.15	799	1.28	834	1.41	868	1.55	903	1.70	942	1.87	980	2.04	1016	2.22	1049	2.39	1079	2.56	
3740	828	1.50	863	1.64	898	1.79	929	1.94	960	2.08	993	2.25	1027	2.44	1062	2.63	1096	2.82	1127	3.02	
4080	898	1.92	929	2.07	962	2.23	992	2.39	1020	2.55	1048	2.71	1078	2.89	1110	3.09	1142	3.30	—	—	
										<b>3-HP Oversized Motor &amp; Drive</b>											

Continued

External Static Pressure (Inches of Water)																					
		1.10		1.20		1.30		1.40		1.50		1.60		1.70		1.80		1.90		2.00	
CFM	RPM	BHP	RPM	BHP	RPM	BHP	RPM	BHP	RPM	BHP	RPM	BHP	RPM	BHP	RPM	BHP	RPM	BHP	RPM	BHP	
<b>2-HP Standard Motor &amp; Drive</b>										<b>3-HP Oversized Motor &amp; Drive</b>											
2720	998	1.86	1022	1.97	1046	2.09	1069	2.21	1092	2.33	1115	2.45	1136	2.56	1158	2.69	1179	2.80	1200	2.93	
3060	1052	2.26	1077	2.39	1101	2.52	1124	2.66	1146	2.79	1167	2.92	1188	3.05	1209	3.18	1229	3.31	1249	3.45	
3400	1106	2.71	1131	2.86	1155	3.01	1179	3.16	1202	3.31	1222	3.45	—	—	—	—	—	—	—	—	
3740	1157	3.21	1185	3.39	—	—	—	—	—	—	—	—	—	—	—	—	—	—	—	—	
4080	—	—	—	—	—	—	—	—	—	—	—	—	—	—	—	—	—	—	—	—	

For Standard Evaporator Fan Speed (RPM), reference [Table 123](#).

Notes:

Data includes pressure drop due to standard filters and wet coils. No accessories or options are included in pressure drop data.

Refer to [Table 128](#) to determine additional static pressure drop due to other options/accessories.

2-HP Fan Motor Heat (MBH) = 2.000 x Fan BHP+.5000. 3-HP Fan Motor Heat (MBH) = 2.900 x Fan BHP+.4750.

Factory supplied motors, in commercial equipment, are definite purpose motors, specifically designed and tested to operate reliably and continuously at all cataloged conditions. Using the full horsepower range of our fan motors as shown in our tabular data will not result in nuisance tripping or premature motor failure. Our product's warranty will not be affected.

<sup>(1)</sup> Field Supplied Fan Sheave AK79 and Belt AX38 required.

## Performance Data

*(10 Tons Standard Efficiency)*

**Table 73. Belt Drive Evaporator Fan Performance 10 Tons with Electric Heat TSC120A3,4,W,K Downflow Airflow**

CFM	External Static Pressure (Inches of Water)																				
	.10		.20		.30		.40		.50		.60		.70		.80		.90		1.00		
	RPM	BHP	RPM	BHP	RPM	BHP	RPM	BHP	RPM	BHP	RPM	BHP	RPM	BHP	RPM	BHP	RPM	BHP	RPM	BHP	
<b>3-HP Standard Motor &amp; Field Supplied Low Static Drive<sup>(1)</sup></b>																					
3200	—	—	—	—	—	—	—	—	718	0.97	754	1.10	789	1.25	822	1.38	856	1.53	887	1.67	
3600	—	—	—	—	—	—	731	1.08	764	1.20	797	1.33	829	1.48	860	1.63	892	1.79	922	1.95	
4000	—	—	715	1.09	747	1.21	782	1.35	814	1.49	844	1.63	874	1.77	903	1.93	932	2.09	960	2.27	
4400	741	1.27	773	1.40	803	1.53	834	1.67	864	1.82	894	1.98	922	2.13	948	2.28	975	2.44	1001	2.62	
4800	803	1.62	833	1.76	861	1.90	887	2.04	916	2.20	945	2.38	972	2.55	997	2.71	1022	2.87	1046	3.04	
<b>3-HP Oversized Motor &amp; Drive</b>																					

Continued

CFM	External Static Pressure (Inches of Water)																				
	1.10		1.20		1.30		1.40		1.50		1.60		1.70		1.80		1.90		2.00		
	RPM	BHP	RPM	BHP	RPM	BHP	RPM	BHP	RPM	BHP	RPM	BHP	RPM	BHP	RPM	BHP	RPM	BHP	RPM	BHP	
<b>3-HP Standard Motor &amp; Drive</b>																					
3200	917	1.82	945	1.97	973	2.14	999	2.30	1024	2.47	1048	2.65	1072	2.82	1095	3.00	1117	3.17	1140	3.36	
3600	951	2.11	979	2.27	1007	2.43	1033	2.60	1059	2.78	1082	2.95	1107	3.14	1130	3.33	1152	3.52	1173	3.71	
4000	988	2.44	1015	2.62	1042	2.79	1068	2.97	1093	3.15	1117	3.33	1142	3.52	1164	3.70	1187	3.91	1209	4.11	
4400	1028	2.81	1053	3.00	1078	3.19	1103	3.38	1128	3.57	1152	3.77	1176	3.96	1198	4.15	1221	4.36	1243	4.56	
4800	1071	3.23	1095	3.42	1119	3.62	1142	3.83	1166	4.04	1189	4.25	1212	4.46	1233	4.66	1256	4.88	1277	5.09	
<b>5-HP Oversized Motor &amp; Drive</b>																					

For Standard Evaporator Fan Speed (RPM), reference [Table 123](#).

Notes:

Data includes pressure drop due to standard filters and wet coils. No accessories or options are included in pressure drop data.

Refer to [Table 128](#) to determine additional static pressure drop due to other options/accessories.

3-HP Fan Motor Heat (MBH) = 2.900 x Fan BHP+.475. 5-HP Fan Motor Heat (MBH) = 2.950 x Fan BHP+.470.

Factory supplied motors, in commercial equipment, are definite purpose motors, specifically designed and tested to operate reliably and continuously at all cataloged conditions. Using the full horsepower range of our fan motors as shown in our tabular data will not result in nuisance tripping or premature motor failure. Our product's warranty will not be affected.

<sup>(1)</sup> Field Supplied Motor Sheave 1VM50 x 7/8", Fan Sheave AK89 and Belt AX40 required.

**Table 74. Belt Drive Evaporator Fan Performance 10 Tons with Electric Heat TSC120A3,4,W,K Horizontal Airflow**

CFM	External Static Pressure (Inches of Water)																				
	.10		.20		.30		.40		.50		.60		.70		.80		.90		1.00		
	RPM	BHP	RPM	BHP	RPM	BHP	RPM	BHP	RPM	BHP	RPM	BHP	RPM	BHP	RPM	BHP	RPM	BHP	RPM	BHP	
<b>3-HP Standard Motor &amp; Field Supplied Low Static Drive<sup>(1)</sup></b>																					
3200	—	—	—	—	730	1.00	771	1.13	807	1.26	844	1.39	886	1.55	926	1.72	965	1.89	1000	2.06	
3600	729	1.13	761	1.22	792	1.32	829	1.45	865	1.60	898	1.74	930	1.89	965	2.06	1002	2.24	1038	2.43	
4000	802	1.52	833	1.63	860	1.73	890	1.86	923	2.01	956	2.17	986	2.32	1015	2.48	1044	2.65	1077	2.85	
4400	876	1.99	905	2.12	931	2.24	955	2.35	983	2.49	1014	2.66	1045	2.84	1072	3.01	1098	3.18	1125	3.36	
4800	950	2.56	977	2.70	1002	2.84	1025	2.96	1048	3.08	1074	3.24	1102	3.43	1131	3.63	1156	3.81	1181	4.00	
<b>3-HP Standard Motor &amp; Drive</b>																<b>5-HP Oversized Motor &amp; Drive</b>					

Continued

CFM	External Static Pressure (Inches of Water)																				
	1.10		1.20		1.30		1.40		1.50		1.60		1.70		1.80		1.90		2.00		
	RPM	BHP	RPM	BHP	RPM	BHP	RPM	BHP	RPM	BHP	RPM	BHP	RPM	BHP	RPM	BHP	RPM	BHP	RPM	BHP	
<b>3-HP Standard Motor &amp; Drive</b>																					
3200	1029	2.20	1057	2.35	1084	2.49	1108	2.63	1132	2.77	1155	2.91	1177	3.05	1198	3.18	1219	3.32	1239	3.46	
3600	1072	2.62	1106	2.81	1134	2.98	1160	3.15	1185	3.31	1209	3.47	1231	3.63	1252	3.78	1274	3.94	1295	4.10	
4000	1111	3.05	1143	3.26	1174	3.47	1204	3.68	1232	3.88	1260	4.09	1283	4.27	1306	4.46	1327	4.63	1349	4.81	
4400	1152	3.55	1182	3.76	1211	3.99	1241	4.21	1270	4.44	1299	4.68	1327	4.91	1352	5.14	1377	5.37	1400	5.57	
4800	1205	4.19	1229	4.39	1253	4.58	1280	4.81	1309	5.06	1336	5.31	1363	5.56	—	—	—	—	—	—	
<b>5-HP Oversized Motor &amp; Drive</b>																					

For Standard Evaporator Fan Speed (RPM), reference [Table 123](#).

Notes:

Data includes pressure drop due to standard filters and wet coils. No accessories or options are included in pressure drop data.

Refer to [Table 128](#) to determine additional static pressure drop due to other options/accessories.

3-HP Fan Motor Heat (MBH) = 2.900 x Fan BHP+.475. 5-HP Fan Motor Heat (MBH) = 2.950 x Fan BHP+.470.

Factory supplied motors, in commercial equipment, are definite purpose motors, specifically designed and tested to operate reliably and continuously at all cataloged conditions. Using the full horsepower range of our fan motors as shown in our tabular data will not result in nuisance tripping or premature motor failure. Our product's warranty will not be affected.

<sup>(1)</sup> Field Supplied Motor Sheave 1VM50 x 7/8", Fan Sheave AK89 and Belt AX40 required.

**Performance Data**

*(10 Tons Standard Efficiency)*

**Table 75. Belt Drive Evaporator Fan Performance 10 Tons with Gas Heat YSC120A3,4,W,K\*L,M Low & Medium Heat Downflow Airflow**

External Static Pressure (Inches of Water)																					
		.10		.20		.30		.40		.50		.60		.70		.80		.90		1.00	
CFM	RPM	BHP	RPM	BHP	RPM	BHP	RPM	BHP	RPM	BHP	RPM	BHP	RPM	BHP	RPM	BHP	RPM	BHP	RPM	BHP	
<b>3-HP Standard Motor &amp; Field Supplied Low Static Drive<sup>(1)</sup></b>																					
3200	—	—	—	—	—	—	727	1.00	763	1.14	798	1.28	832	1.42	863	1.56	895	1.71	924	1.86	
3600	—	—	717	1.03	751	1.15	784	1.28	816	1.42	848	1.57	879	1.73	910	1.89	940	2.05	968	2.20	
4000	746	1.21	780	1.35	813	1.49	843	1.62	873	1.76	902	1.92	931	2.09	959	2.26	986	2.43	1014	2.61	
4400	814	1.57	845	1.73	876	1.88	905	2.03	932	2.18	959	2.34	985	2.51	1012	2.69	1037	2.88	1063	3.07	
4800	883	2.02	911	2.18	940	2.35	967	2.52	993	2.68	1018	2.84	1042	3.01	1067	3.20	1091	3.39	1115	3.59	
<b>3-HP Standard Motor &amp; Drive</b>														<b>5-HP Oversized Motor &amp; Drive</b>							

Continued

External Static Pressure (Inches of Water)																					
		1.10		1.20		1.30		1.40		1.50		1.60		1.70		1.80		1.90		2.00	
CFM	RPM	BHP	RPM	BHP	RPM	BHP	RPM	BHP	RPM	BHP	RPM	BHP	RPM	BHP	RPM	BHP	RPM	BHP	RPM	BHP	
<b>3-HP Standard Motor &amp; Drive</b>																					
3200	952	2.01	979	2.18	1004	2.34	1029	2.51	1053	2.68	1078	2.86	1101	3.04	1124	3.23	1146	3.41	1169	3.59	
3600	996	2.37	1023	2.53	1049	2.71	1073	2.88	1097	3.07	1120	3.25	1142	3.43	1164	3.63	1186	3.83	1207	4.02	
4000	1041	2.79	1067	2.96	1092	3.14	1117	3.33	1141	3.51	1164	3.70	1186	3.90	1208	4.10	1228	4.30	1249	4.51	
4400	1088	3.26	1113	3.45	1137	3.64	1162	3.84	1185	4.04	1207	4.23	1229	4.43	1252	4.65	1273	4.85	1293	5.06	
4800	1139	3.80	1161	4.00	1185	4.22	1208	4.43	1230	4.63	1253	4.85	1275	5.06	1295	5.27	1317	5.49	1337	5.71	
<b>3-HP Standard Motor &amp; Drive</b>														<b>5-HP Oversized Motor &amp; Drive</b>							

For Standard Evaporator Fan Speed (RPM), reference [Table 123](#).

Notes: Data includes pressure drop due to standard filters and wet coils. No accessories or options are included in pressure drop data.

Refer to [Table 128](#) to determine additional static pressure drop due to other options/accessories.

3-HP Fan Motor Heat (MBH) = 2.900 x Fan BHP+.475. 5-HP Fan Motor Heat (MBH) = 2.950 x Fan BHP+.470.

Factory supplied motors, in commercial equipment, are definite purpose motors, specifically designed and tested to operate reliably and continuously at all cataloged conditions. Using the full horsepower range of our fan motors as shown in our tabular data will not result in nuisance tripping or premature motor failure. Our product's warranty will not be affected.

<sup>(1)</sup> Field Supplied Motor Sheave 1VM50 x 7/8", Fan Sheave AK89 and Belt AX40 required.

**Table 76. Belt Drive Evaporator Fan Performance 10 Tons with Gas Heat YSC120A3,4,W,K\*H High Heat Downflow Airflow**

External Static Pressure (Inches of Water)																					
		.10		.20		.30		.40		.50		.60		.70		.80		.90		1.00	
CFM	RPM	BHP	RPM	BHP	RPM	BHP	RPM	BHP	RPM	BHP	RPM	BHP	RPM	BHP	RPM	BHP	RPM	BHP	RPM	BHP	
<b>3-HP Standard Motor &amp; Field Supplied Low Static Drive<sup>(1)</sup></b>																					
3200	—	—	—	—	723	0.99	759	1.12	793	1.26	827	1.40	860	1.55	891	1.69	921	1.84	949	2.00	
3600	721	1.04	755	1.17	787	1.29	820	1.44	851	1.59	882	1.75	913	1.90	942	2.06	971	2.22	999	2.39	
4000	793	1.40	824	1.54	854	1.67	883	1.82	913	1.98	941	2.15	969	2.32	997	2.50	1024	2.67	1050	2.85	
4400	866	1.83	895	1.98	923	2.13	949	2.28	976	2.45	1003	2.63	1029	2.81	1054	3.00	1079	3.20	1104	3.39	
4800	939	2.34	967	2.51	992	2.67	1017	2.84	1042	3.01	1066	3.19	1090	3.38	1114	3.58	1138	3.79	1161	4.00	
<b>3-HP Standard Motor &amp; Drive</b>														<b>5-HP Oversized Motor &amp; Drive</b>							

Continued

External Static Pressure (Inches of Water)																					
		1.10		1.20		1.30		1.40		1.50		1.60		1.70		1.80		1.90		2.00	
CFM	RPM	BHP	RPM	BHP	RPM	BHP	RPM	BHP	RPM	BHP	RPM	BHP	RPM	BHP	RPM	BHP	RPM	BHP	RPM	BHP	
<b>3-HP Standard Motor &amp; Drive</b>																					
3200	976	2.16	1001	2.32	1027	2.49	1051	2.66	1075	2.84	1098	3.02	1120	3.19	1143	3.38	1166	3.57	1189	3.75	
3600	1025	2.55	1052	2.73	1076	2.90	1100	3.09	1122	3.27	1145	3.46	1167	3.66	1188	3.85	1210	4.05	1230	4.25	
4000	1076	3.03	1101	3.20	1126	3.40	1149	3.58	1172	3.77	1194	3.97	1216	4.18	1236	4.38	1257	4.59	1277	4.80	
4400	1129	3.58	1153	3.77	1176	3.97	1200	4.17	1222	4.37	1244	4.57	1266	4.78	1286	4.99	1307	5.21	1326	5.43	
4800	1184	4.21	1207	4.42	1229	4.63	1252	4.84	1274	5.06	1295	5.27	1315	5.48	1336	5.70	—	—	—	—	
<b>3-HP Standard Motor &amp; Drive</b>														<b>5-HP Oversized Motor &amp; Drive</b>							

For Standard Evaporator Fan Speed (RPM), reference [Table 123](#).

Notes: Data includes pressure drop due to standard filters and wet coils. No accessories or options are included in pressure drop data.

Refer to [Table 128](#) to determine additional static pressure drop due to other options/accessories.

3-HP Fan Motor Heat (MBH) = 2.900 x Fan BHP+.475. 5-HP Fan Motor Heat (MBH) = 2.950 x Fan BHP+.470.

Factory supplied motors, in commercial equipment, are definite purpose motors, specifically designed and tested to operate reliably and continuously at all cataloged conditions. Using the full horsepower range of our fan motors as shown in our tabular data will not result in nuisance tripping or premature motor failure. Our product's warranty will not be affected.

<sup>(1)</sup> Field Supplied Motor Sheave 1VM50 x 7/8", Fan Sheave AK89 and Belt AX40 required.

## Performance Data

*(10 Tons Standard Efficiency)*

**Table 77. Belt Drive Evaporator Fan Performance 10 Tons with Gas Heat YSC120A3,4,W,K\*L,M Low & Medium Heat Horizontal Airflow**

External Static Pressure (Inches of Water)																					
		.10		.20		.30		.40		.50		.60		.70		.80		.90		1.00	
CFM	RPM	BHP	RPM	BHP	RPM	BHP	RPM	BHP	RPM	BHP	RPM	BHP	RPM	BHP	RPM	BHP	RPM	BHP	RPM	BHP	
<b>3-HP Standard Motor &amp; Field Supplied Low Static Drive<sup>(1)</sup></b>										<b>3-HP Standard Motor &amp; Drive</b>											
3200	—	—	761	1.10	798	1.22	834	1.35	875	1.51	916	1.68	955	1.85	991	2.01	1022	2.16	1050	2.31	
3600	799	1.35	836	1.48	872	1.63	904	1.77	936	1.91	972	2.09	1009	2.28	1045	2.47	1079	2.66	1111	2.84	
4000	881	1.81	913	1.96	947	2.12	977	2.28	1006	2.44	1035	2.60	1066	2.78	1100	2.99	1133	3.20	1165	3.41	
4400	963	2.39	992	2.54	1023	2.71	1052	2.89	1079	3.06	1106	3.23	1132	3.41	1160	3.61	1189	3.82	1219	4.05	
4800	1045	3.07	1072	3.23	1099	3.41	1127	3.61	1154	3.80	1179	3.98	1203	4.17	1227	4.36	1251	4.56	1278	4.80	
										<b>5-HP Oversized Motor &amp; Drive</b>											

Continued

External Static Pressure (Inches of Water)																					
		1.10		1.20		1.30		1.40		1.50		1.60		1.70		1.80		1.90		2.00	
CFM	RPM	BHP	RPM	BHP	RPM	BHP	RPM	BHP	RPM	BHP	RPM	BHP	RPM	BHP	RPM	BHP	RPM	BHP	RPM	BHP	
<b>3-HP Standard Motor &amp; Drive</b>										<b>5-HP Oversized Motor &amp; Drive</b>											
3200	1077	2.45	1103	2.60	1126	2.73	1150	2.87	1171	3.01	1193	3.15	1214	3.29	1233	3.42	1253	3.56	1274	3.71	
3600	1140	3.02	1165	3.18	1190	3.34	1214	3.51	1235	3.66	1257	3.82	1279	3.98	1298	4.13	1317	4.28	1338	4.45	
4000	1196	3.62	1225	3.83	1252	4.03	1276	4.22	1299	4.40	1321	4.58	1342	4.76	1363	4.94	1383	5.11	1401	5.28	
4400	1250	4.28	1280	4.52	1307	4.75	1334	4.98	1359	5.20	1384	5.43	1405	5.62	—	—	—	—	—	—	
4800	1305	5.03	1334	5.28	1361	5.54	—	—	—	—	—	—	—	—	—	—	—	—	—	—	

For Standard Evaporator Fan Speed (RPM), reference [Table 123](#).

Notes:

Data includes pressure drop due to standard filters and wet coils. No accessories or options are included in pressure drop data.

Refer to [Table 128](#) to determine additional static pressure drop due to other options/accessories.

3-HP Fan Motor Heat (MBH) = 2.900 x Fan BHP+.475. 5-HP Fan Motor Heat (MBH) = 2.950 x Fan BHP+.470.

Factory supplied motors, in commercial equipment, are definite purpose motors, specifically designed and tested to operate reliably and continuously at all cataloged conditions. Using the full horsepower range of our fan motors as shown in our tabular data will not result in nuisance tripping or premature motor failure. Our product's warranty will not be affected.

<sup>(1)</sup> Field Supplied Motor Sheave 1VM50 x 7/8", Fan Sheave AK89 and Belt AX40 required.

**Table 78. Belt Drive Evaporator Fan Performance 10 Tons with Gas Heat YSC120A3,4,W,K\*H High Heat Horizontal Airflow**

External Static Pressure (Inches of Water)																					
		.10		.20		.30		.40		.50		.60		.70		.80		.90		1.00	
CFM	RPM	BHP	RPM	BHP	RPM	BHP	RPM	BHP	RPM	BHP	RPM	BHP	RPM	BHP	RPM	BHP	RPM	BHP	RPM	BHP	
<b>3-HP Standard Motor &amp; Field Supplied Low Static Drive<sup>(1)</sup></b>										<b>3-HP Standard Motor &amp; Drive</b>											
3200	768	1.12	805	1.25	842	1.38	884	1.54	924	1.71	962	1.88	998	2.04	1028	2.19	1055	2.34	1082	2.48	
3600	856	1.56	888	1.70	921	1.84	955	2.00	992	2.19	1028	2.37	1063	2.57	1096	2.75	1126	2.93	1153	3.10	
4000	943	2.10	973	2.26	1002	2.41	1031	2.58	1062	2.76	1096	2.96	1129	3.17	1161	3.38	1192	3.59	1222	3.81	
4400	1031	2.76	1060	2.94	1086	3.11	1113	3.28	1139	3.45	1167	3.66	1198	3.89	1228	4.11	1257	4.34	1287	4.58	
4800	1119	3.45	1146	3.74	1171	3.93	1195	4.11	1219	4.30	1243	4.50	1270	4.72	1297	4.96	1325	5.21	1353	5.46	
										<b>5-HP Oversized Motor &amp; Drive</b>											

Continued

External Static Pressure (Inches of Water)																					
		1.10		1.20		1.30		1.40		1.50		1.60		1.70		1.80		1.90		2.00	
CFM	RPM	BHP	RPM	BHP	RPM	BHP	RPM	BHP	RPM	BHP	RPM	BHP	RPM	BHP	RPM	BHP	RPM	BHP	RPM	BHP	
<b>3-HP Standard Motor &amp; Drive</b>										<b>5-HP Oversized Motor &amp; Drive</b>											
3200	1107	2.62	1131	2.76	1154	2.90	1176	3.04	1197	3.17	1218	3.32	1238	3.46	1257	3.59	1276	3.73	1296	3.87	
3600	1178	3.27	1202	3.42	1224	3.58	1247	3.74	1268	3.90	1288	4.05	1308	4.21	1328	4.37	1346	4.52	1366	4.69	
4000	1249	4.01	1273	4.19	1296	4.38	1318	4.56	1339	4.73	1361	4.91	1380	5.08	1399	5.26	1418	5.44	—	—	
4400	1315	4.81	1340	5.03	1366	5.26	1389	5.48	1410	5.67	—	—	—	—	—	—	—	—	—	—	
4800	1379	5.71	—	—	—	—	—	—	—	—	—	—	—	—	—	—	—	—	—	—	

For Standard Evaporator Fan Speed (RPM), reference [Table 123](#).

Notes:

Data includes pressure drop due to standard filters and wet coils. No accessories or options are included in pressure drop data.

Refer to [Table 128](#) to determine additional static pressure drop due to other options/accessories.

3-HP Fan Motor Heat (MBH) = 2.900 x Fan BHP+.475. 5-HP Fan Motor Heat (MBH) = 2.950 x Fan BHP+.470.

Factory supplied motors, in commercial equipment, are definite purpose motors, specifically designed and tested to operate reliably and continuously at all cataloged conditions. Using the full horsepower range of our fan motors as shown in our tabular data will not result in nuisance tripping or premature motor failure. Our product's warranty will not be affected.

<sup>(1)</sup> Field Supplied Motor Sheave 1VM50 x 7/8", Fan Sheave AK89 and Belt AX40 required.

## Performance Data

*(3 Tons High Efficiency)*

**Table 79. Belt Drive Evaporator Fan Performance 3 Tons 13 SEER THC033A3,4,W Downflow Airflow**

CFM	External Static Pressure (Inches of Water)																			
	.10		.20		.30		.40		.50		.60		.70		.80		.90		1.00	
	RPM	BHP	RPM	BHP	RPM	BHP	RPM	BHP	RPM	BHP	RPM	BHP	RPM	BHP	RPM	BHP	RPM	BHP	RPM	BHP
<b>1-HP Standard Motor &amp; Low Static Drive Accessory Kit<sup>(i)</sup></b>													<b>1-HP Standard Motor &amp; Drive</b>							
600*	—	—	449	0.06	525	0.09	593	0.12	653	0.16	707	0.20	757	0.23	802	0.27	845	0.31	885	0.36
720*	—	—	475	0.08	547	0.11	612	0.14	669	0.18	724	0.22	774	0.26	821	0.31	864	0.35	905	0.40
840*	—	—	501	0.10	572	0.13	634	0.17	690	0.21	742	0.25	791	0.29	837	0.34	881	0.39	922	0.44
960	—	—	528	0.12	599	0.16	658	0.20	713	0.24	763	0.29	810	0.33	855	0.38	898	0.43	939	0.49
1080	—	—	557	0.15	625	0.19	685	0.24	738	0.28	786	0.33	832	0.38	876	0.43	917	0.48	957	0.54
1200	—	—	588	0.19	652	0.23	712	0.28	764	0.33	811	0.38	856	0.43	898	0.48	939	0.54	978	0.59
1320	552	0.18	622	0.23	681	0.27	738	0.32	790	0.38	838	0.44	882	0.49	923	0.55	962	0.60	1000	0.66
1440	588	0.23	657	0.28	713	0.33	765	0.37	817	0.43	865	0.50	909	0.56	949	0.62	987	0.68	1024	0.74

**Continued**

CFM	External Static Pressure (Inches of Water)									
	1.10		1.20		1.30		1.40		1.50	
	RPM	BHP	RPM	BHP	RPM	BHP	RPM	BHP	RPM	BHP
<b>1-HP Standard Motor &amp; Drive</b>										
600*	924	0.40	962	0.45	997	0.49	1031	0.54	1065	0.59
720*	943	0.45	980	0.50	1016	0.55	1050	0.60	1082	0.65
840*	962	0.50	999	0.55	1034	0.60	1068	0.66	1103	0.71
960	978	0.54	1016	0.60	1052	0.66	1086	0.72	1120	0.78
1080	995	0.59	1033	0.65	1069	0.71	1103	0.78	1136	0.84
1200	1015	0.65	1051	0.71	1086	0.77	1120	0.84	1154	0.91
1320	1036	0.72	1072	0.78	1106	0.85	1138	0.91	1171	0.98
1440	1060	0.80	1094	0.86	1128	0.93	1160	1.00	1192	1.07
<b>1-HP Standard Motor &amp; Field Supplied High Static Drive<sup>(ii)</sup></b>										

For Standard Evaporator Fan Speed (RPM), reference [Table 123](#).

Notes: Data includes pressure drop due to standard filters and wet coils. No accessories or options are included in pressure drop data. Data does not include pressure drop due to reheat coil.

Refer to [Table 128](#) to determine additional static pressure drop due to other options/accessories.

1-HP Fan Motor Heat (MBH) = 2.829 x Fan BHP + .4024.

Factory supplied motors, in commercial equipment, are definite purpose motors, specifically designed and tested to operate reliably and continuously at all cataloged conditions. Using the full horsepower range of our fan motors as shown in our tabular data will not result in nuisance tripping or premature motor failure. Our product's warranty will not be affected.

Table includes Dehumidification (Hot Gas Reheat Option).

\*Unit applications below 960 CFM

- Electric heaters restricted on applications below 960 CFM.
- Dehumidification (Hot Gas Reheat) or TXV with Froststat and Crank-case Heaters are required on applications below 960 CFM.

<sup>(i)</sup> BAYLSDR006 required.

<sup>(ii)</sup> Field Supplied Fan Sheave AK41 required. Field Supplied Belt may be necessary.

## Performance Data

*(3 Tons High Efficiency)*

**Table 80. Belt Drive Evaporator Fan Performance 3 Tons 13 SEER THC033A3,4,W Horizontal Airflow**

CFM	External Static Pressure (Inches of Water)																			
	.10		.20		.30		.40		.50		.60		.70		.80		.90		1.00	
	RPM	BHP	RPM	BHP	RPM	BHP	RPM	BHP	RPM	BHP	RPM	BHP	RPM	BHP	RPM	BHP	RPM	BHP	RPM	BHP
<b>1-HP Standard Motor &amp; Low Static Drive Accessory Kit<sup>(i)</sup></b>											<b>1-HP Standard Motor &amp; Drive</b>									
600*	—	—	493	0.07	567	0.11	628	0.14	683	0.18	737	0.22	786	0.26	832	0.30	876	0.35	918	0.40
720*	427	0.06	523	0.09	599	0.13	662	0.17	716	0.21	766	0.25	811	0.29	856	0.34	899	0.39	940	0.44
840*	460	0.08	555	0.12	631	0.16	694	0.21	750	0.25	799	0.30	844	0.35	886	0.39	925	0.44	965	0.49
960	493	0.10	588	0.15	661	0.19	725	0.24	782	0.29	832	0.35	878	0.40	919	0.46	958	0.51	996	0.56
1080	531	0.13	622	0.18	694	0.24	756	0.29	813	0.34	864	0.40	910	0.46	954	0.52	993	0.59	1031	0.65
1200	570	0.17	654	0.23	727	0.28	787	0.34	843	0.40	895	0.46	942	0.52	986	0.59	1026	0.66	1064	0.73
1320	610	0.22	687	0.28	760	0.34	821	0.40	875	0.46	925	0.53	973	0.59	1017	0.66	1058	0.73	1095	0.81
1440	651	0.27	723	0.33	793	0.40	855	0.47	908	0.53	956	0.60	1003	0.67	1047	0.75	1088	0.82	1127	0.89

**Continued**

CFM	External Static Pressure (Inches of Water)									
	1.10		1.20		1.30		1.40		1.50	
	RPM	BHP	RPM	BHP	RPM	BHP	RPM	BHP	RPM	BHP
<b>1-HP Standard Motor &amp; Drive</b>										
600*	958	0.45	996	0.50	1032	0.55	1068	0.60	1102	0.66
720*	978	0.49	1016	0.55	1053	0.61	1087	0.66	1121	0.72
840*	1002	0.55	1039	0.60	1076	0.67	1109	0.72	1143	0.79
960	1032	0.62	1066	0.67	1101	0.73	1133	0.79	1166	0.86
1080	1065	0.70	1099	0.76	1132	0.82	1164	0.89	1194	0.95
1200	1099	0.80	1133	0.86	1166	0.93	1197	0.99	1227	1.06
1320	1132	0.88	1167	0.96	1200	1.04	1230	1.11	1261	1.19
1440	1164	0.97	1199	1.05	1232	1.14	1263	1.22	1294	1.30
<b>1-HP Standard Motor &amp; Field Supplied High Static Drive<sup>(iii)</sup></b>										

For Standard Evaporator Fan Speed (RPM), reference [Table 123](#).  
 Notes: Data includes pressure drop due to standard filters and wet coils. No accessories or options are included in pressure drop data. Data does not include pressure drop due to reheat coil. Refer to [Table 128](#) to determine additional static pressure drop due to other options/accessories.  
 1-HP Fan Motor Heat (MBH) = 2.829 x Fan BHP + .4024.  
 Factory supplied motors, in commercial equipment, are definite purpose motors, specifically designed and tested to operate reliably and continuously at all cataloged conditions. Using the full horsepower range of our fan motors as shown in our tabular data will not result in nuisance tripping or premature motor failure. Our product's warranty will not be affected.  
 Table includes Dehumidification (Hot Gas Reheat Option).  
 \*Unit applications below 960 CFM

- Electric heaters restricted on applications below 960 CFM.
- Dehumidification (Hot Gas Reheat) or TXV with Froststat and Crank-case Heaters are required on applications below 960 CFM.

<sup>(i)</sup> BAYLSDR006 required.  
<sup>(ii)</sup> Field Supplied Fan Sheave AK41 required. Field Supplied Belt may be necessary.  
<sup>(iii)</sup> Field Supplied Fan Sheave AK41 required. Field Supplied Belt may be necessary.

## Performance Data

*(3 Tons High Efficiency)*

**Table 81. Belt Drive Evaporator Fan Performance 3 Tons 13 SEER YHC033A3,4,W\*L,M Low & Medium Heat Downflow Airflow**

CFM	External Static Pressure (Inches of Water)																			
	.10		.20		.30		.40		.50		.60		.70		.80		.90		1.00	
	RPM	BHP	RPM	BHP	RPM	BHP	RPM	BHP	RPM	BHP	RPM	BHP	RPM	BHP	RPM	BHP	RPM	BHP	RPM	BHP
<b>1-HP Standard Motor &amp; Field Supplied Low Static Drive<sup>(i)</sup></b>										<b>1-HP Standard Motor &amp; Drive</b>										
960	—	—	570	0.14	634	0.18	690	0.22	741	0.27	791	0.31	836	0.36	879	0.41	922	0.46	961	0.52
1080	537	0.14	606	0.18	669	0.23	724	0.27	773	0.32	819	0.36	864	0.41	906	0.47	946	0.52	985	0.58
1200	581	0.18	645	0.22	705	0.27	759	0.33	807	0.38	851	0.42	894	0.48	935	0.53	973	0.59	1011	0.65
1320	627	0.23	686	0.28	742	0.33	795	0.39	842	0.44	885	0.50	927	0.55	966	0.61	1003	0.67	1040	0.73
1440	673	0.29	728	0.34	780	0.39	831	0.45	878	0.52	921	0.58	960	0.64	998	0.69	1034	0.76	1070	0.82

**Continued**

CFM	External Static Pressure (Inches of Water)									
	1.10		1.20		1.30		1.40		1.50	
	RPM	BHP	RPM	BHP	RPM	BHP	RPM	BHP	RPM	BHP
<b>1-HP Standard Motor &amp; Drive</b>										
960	1000	0.57	1037	0.63	1072	0.69	1106	0.75	1139	0.81
1080	1022	0.64	1058	0.70	1093	0.76	1127	0.82	1161	0.89
1200	1047	0.71	1083	0.77	1117	0.83	1150	0.90	1183	0.97
1320	1075	0.79	1108	0.85	1141	0.92	1174	0.99	1206	1.06
1440	1104	0.88	1137	0.95	1170	1.02	1201	1.09	1231	1.16
<b>1-HP Standard Motor &amp; Field Supplied High Static Drive<sup>(ii)</sup></b>										

For Standard Evaporator Fan Speed (RPM), reference [Table 123](#).  
 Notes: Data includes pressure drop due to standard filters and wet coils. No accessories or options are included in pressure drop data. Data does not include pressure drop due to reheat coil. Refer to [Table 128](#) to determine additional static pressure drop due to other options/accessories.  
 1-HP Fan Motor Heat (MBH) = 2.829 x Fan BHP + .4024.  
 Factory supplied motors, in commercial equipment, are definite purpose motors, specifically designed and tested to operate reliably and continuously at all cataloged conditions. Using the full horsepower range of our fan motors as shown in our tabular data will not result in nuisance tripping or premature motor failure. Our product's warranty will not be affected.

<sup>(i)</sup> Field Supplied Fan Sheave AK69 required. Field Supplied Belt may be necessary.  
<sup>(ii)</sup> Field Supplied Fan Sheave AK41 required. Field Supplied Belt may be necessary.

**Table 82. Belt Drive Evaporator Fan Performance 3 Tons 13 SEER YHC033A3,4,W\*H High Heat Downflow Airflow**

CFM	External Static Pressure (Inches of Water)																			
	.10		.20		.30		.40		.50		.60		.70		.80		.90		1.00	
	RPM	BHP	RPM	BHP	RPM	BHP	RPM	BHP	RPM	BHP	RPM	BHP	RPM	BHP	RPM	BHP	RPM	BHP	RPM	BHP
<b>1-HP Standard Motor &amp; Field Supplied Low Static Drive<sup>(i)</sup></b>										<b>1-HP Standard Motor &amp; Drive</b>										
960	503	0.11	578	0.15	641	0.19	696	0.23	747	0.27	796	0.32	841	0.36	884	0.42	926	0.47	966	0.52
1080	548	0.15	616	0.19	678	0.23	731	0.28	780	0.32	826	0.37	870	0.42	912	0.47	952	0.53	991	0.59
1200	593	0.19	657	0.23	716	0.28	768	0.33	815	0.38	859	0.43	901	0.49	942	0.54	980	0.60	1017	0.66
1320	640	0.24	698	0.29	754	0.34	806	0.40	852	0.45	895	0.51	935	0.56	974	0.62	1012	0.68	1048	0.74
1440	688	0.31	742	0.35	794	0.41	844	0.47	890	0.53	931	0.59	970	0.65	1009	0.71	1045	0.77	1080	0.84

**Continued**

CFM	External Static Pressure (Inches of Water)									
	1.10		1.20		1.30		1.40		1.50	
	RPM	BHP	RPM	BHP	RPM	BHP	RPM	BHP	RPM	BHP
<b>1-HP Standard Motor &amp; Drive</b>										
960	1005	0.58	1041	0.64	1076	0.70	1110	0.76	1142	0.82
1080	1029	0.65	1064	0.71	1099	0.77	1133	0.83	1166	0.90
1200	1053	0.72	1089	0.78	1123	0.85	1156	0.91	1189	0.98
1320	1082	0.80	1116	0.87	1150	0.93	1182	1.00	1214	1.07
1440	1113	0.90	1146	0.97	1178	1.04	1209	1.11	1240	1.18
<b>1-HP Standard Motor &amp; Field Supplied High Static Drive<sup>(ii)</sup></b>										

For Standard Evaporator Fan Speed (RPM), reference [Table 123](#).  
 Notes: Data includes pressure drop due to standard filters and wet coils. No accessories or options are included in pressure drop data. Data does not include pressure drop due to reheat coil. Refer to [Table 128](#) to determine additional static pressure drop due to other options/accessories.  
 1-HP Fan Motor Heat (MBH) = 2.829 x Fan BHP + .4024.  
 Factory supplied motors, in commercial equipment, are definite purpose motors, specifically designed and tested to operate reliably and continuously at all cataloged conditions. Using the full horsepower range of our fan motors as shown in our tabular data will not result in nuisance tripping or premature motor failure. Our product's warranty will not be affected.

<sup>(i)</sup> Field Supplied Fan Sheave AK69 required. Field Supplied Belt may be necessary.  
<sup>(ii)</sup> Field Supplied Fan Sheave AK41 required. Field Supplied Belt may be necessary.



## Performance Data

*(3 Tons High Efficiency)*

**Table 83. Belt Drive Evaporator Fan Performance 3 Tons 13 SEER YHC033A3,4,W\*L,M Low & Medium Heat Horizontal Airflow**

External Static Pressure (Inches of Water)																					
		.10		.20		.30		.40		.50		.60		.70		.80		.90		1.00	
CFM	RPM	BHP	RPM	BHP	RPM	BHP	RPM	BHP	RPM	BHP	RPM	BHP	RPM	BHP	RPM	BHP	RPM	BHP	RPM	BHP	
<b>1-HP Standard Motor &amp; Field Supplied Low Static Drive<sup>(i)</sup></b>										<b>1-HP Standard Motor &amp; Drive</b>											
960	552	0.13	631	0.17	699	0.22	759	0.27	811	0.33	858	0.38	902	0.44	943	0.49	980	0.54	1017	0.60	
1080	598	0.17	675	0.22	739	0.27	798	0.33	850	0.38	898	0.44	941	0.50	982	0.57	1020	0.63	1056	0.69	
1200	645	0.22	720	0.28	781	0.33	837	0.39	889	0.45	937	0.51	981	0.58	1021	0.65	1059	0.72	1095	0.79	
1320	693	0.28	766	0.34	825	0.40	879	0.47	929	0.53	976	0.60	1020	0.67	1061	0.74	1099	0.81	1135	0.89	
1440	743	0.35	811	0.42	871	0.49	922	0.55	970	0.62	1016	0.69	1059	0.77	1099	0.84	1138	0.92	1174	1.00	
<b>Continued</b>										<b>1-HP Standard Motor &amp; Field Supplied High Static Drive<sup>(ii)</sup></b>											
External Static Pressure (Inches of Water)																					
		1.10		1.20		1.30		1.40		1.50											
CFM	RPM	BHP	RPM	BHP	RPM	BHP	RPM	BHP	RPM	BHP											
<b>1-HP Standard Motor &amp; Drive</b>																					
960	1052	0.65	1086	0.71	1120	0.77	1152	0.83	1185	0.90											
1080	1090	0.75	1123	0.81	1154	0.87	1185	0.93	1215	0.99											
1200	1130	0.86	1162	0.92	1193	0.99	1224	1.05	1253	1.12											
1320	1169	0.96	1203	1.04	1233	1.12	1263	1.19	1292	1.26											
1440	1208	1.08	1241	1.16	1273	1.25	1303	1.33	1332	1.41											
<b>1-HP Standard Motor &amp; Field Supplied High Static Drive<sup>(iii)</sup></b>																					

For Standard Evaporator Fan Speed (RPM), reference [Table 123](#).  
 Notes: Data includes pressure drop due to standard filters and wet coils. No accessories or options are included in pressure drop data. Data does not include pressure drop due to reheat coil. Refer to [Table 128](#) to determine additional static pressure drop due to other options/accessories.  
 1-HP Fan Motor Heat (MBH) = 2.829 x Fan BHP+.4024.  
 Factory supplied motors, in commercial equipment, are definite purpose motors, specifically designed and tested to operate reliably and continuously at all cataloged conditions. Using the full horsepower range of our fan motors as shown in our tabular data will not result in nuisance tripping or premature motor failure. Our product's warranty will not be affected.

<sup>(i)</sup> Field Supplied Fan Sheave AK69 required. Field Supplied Belt may be necessary.  
<sup>(ii)</sup> Field Supplied Fan Sheave AK41 required. Field Supplied Belt may be necessary.  
<sup>(iii)</sup> Field Supplied Fan Sheave AK41 required. Field Supplied Belt may be necessary.

**Table 84. Belt Drive Evaporator Fan Performance 3 Tons 13 SEER YHC033A3,4,W\*H High Heat Horizontal Airflow**

External Static Pressure (Inches of Water)																					
		.10		.20		.30		.40		.50		.60		.70		.80		.90		1.00	
CFM	RPM	BHP	RPM	BHP	RPM	BHP	RPM	BHP	RPM	BHP	RPM	BHP	RPM	BHP	RPM	BHP	RPM	BHP	RPM	BHP	
<b>1-HP Standard Motor &amp; Field Supplied Low Static Drive<sup>(i)</sup></b>										<b>1-HP Standard Motor &amp; Drive</b>											
960	563	0.13	639	0.18	707	0.23	766	0.28	817	0.33	864	0.39	908	0.44	947	0.49	985	0.55	1020	0.60	
1080	611	0.18	685	0.23	748	0.28	806	0.34	858	0.39	905	0.45	947	0.51	988	0.58	1026	0.64	1061	0.70	
1200	660	0.23	732	0.29	792	0.34	847	0.40	899	0.46	945	0.53	989	0.59	1029	0.66	1066	0.73	1102	0.80	
1320	711	0.29	781	0.36	838	0.42	890	0.48	940	0.55	986	0.61	1029	0.68	1070	0.76	1106	0.83	1142	0.90	
1440	762	0.37	829	0.44	885	0.51	935	0.57	983	0.64	1028	0.71	1070	0.79	1111	0.86	1148	0.94	1183	1.02	
<b>Continued</b>										<b>1-HP Standard Motor &amp; Field Supplied High Static Drive<sup>(ii)</sup></b>											
External Static Pressure (Inches of Water)																					
		1.10		1.20		1.30		1.40		1.50											
CFM	RPM	BHP	RPM	BHP	RPM	BHP	RPM	BHP	RPM	BHP											
<b>1-HP Standard Motor &amp; Drive</b>																					
960	1056	0.66	1090	0.71	1123	0.78	1156	0.84	1188	0.90											
1080	1096	0.76	1128	0.82	1159	0.88	1190	0.94	1220	1.00											
1200	1135	0.87	1168	0.93	1199	1.00	1229	1.07	1259	1.13											
1320	1177	0.98	1209	1.06	1241	1.14	1270	1.21	1299	1.28											
1440	1217	1.10	1250	1.18	1281	1.27	1311	1.35	1339	1.43											
<b>1-HP Standard Motor &amp; Field Supplied High Static Drive<sup>(iii)</sup></b>																					

For Standard Evaporator Fan Speed (RPM), reference [Table 123](#).  
 Notes: Data includes pressure drop due to standard filters and wet coils. No accessories or options are included in pressure drop data. Data does not include pressure drop due to reheat coil. Refer to [Table 128](#) to determine additional static pressure drop due to other options/accessories.  
 1-HP Fan Motor Heat (MBH) = 2.829 x Fan BHP+.4024.  
 Factory supplied motors, in commercial equipment, are definite purpose motors, specifically designed and tested to operate reliably and continuously at all cataloged conditions. Using the full horsepower range of our fan motors as shown in our tabular data will not result in nuisance tripping or premature motor failure. Our product's warranty will not be affected.

<sup>(i)</sup> Field Supplied Fan Sheave AK69 required. Field Supplied Belt may be necessary.  
<sup>(ii)</sup> Field Supplied Fan Sheave AK41 required. Field Supplied Belt may be necessary.  
<sup>(iii)</sup> Field Supplied Fan Sheave AK41 required. Field Supplied Belt may be necessary.

## Performance Data

*(4 Tons High Efficiency)*

**Table 85. Belt Drive Evaporator Fan Performance 4 Tons 13 SEER THC043A3,4,W Downflow Airflow**

CFM	External Static Pressure (Inches of Water)																			
	.10		.20		.30		.40		.50		.60		.70		.80		.90		1.00	
	RPM	BHP	RPM	BHP	RPM	BHP	RPM	BHP	RPM	BHP	RPM	BHP	RPM	BHP	RPM	BHP	RPM	BHP	RPM	BHP
<b>1-HP Standard Motor &amp; Low Static Drive Accessory Kit<sup>(i)</sup></b>										<b>1-HP Standard Motor &amp; Drive</b>										
800*	—	—	501	0.09	571	0.13	633	0.16	690	0.20	742	0.25	792	0.29	838	0.34	882	0.39	923	0.44
960*	459	0.09	539	0.13	609	0.17	668	0.21	721	0.25	771	0.29	819	0.34	864	0.39	906	0.44	947	0.50
1120*	509	0.13	580	0.17	646	0.21	706	0.26	758	0.31	805	0.36	850	0.41	893	0.46	934	0.51	973	0.57
1280	559	0.18	626	0.23	686	0.27	744	0.32	796	0.38	843	0.43	885	0.49	927	0.54	967	0.60	1005	0.66
1440	609	0.24	674	0.30	730	0.34	783	0.39	834	0.45	882	0.52	924	0.58	964	0.64	1002	0.70	1038	0.76
1600	661	0.32	724	0.38	776	0.44	825	0.49	872	0.54	919	0.61	962	0.68	1002	0.75	1039	0.82	1076	0.89
1760	716	0.42	775	0.48	825	0.54	870	0.60	915	0.66	958	0.72	999	0.79	1040	0.87	1078	0.95	1113	1.03
1920	771	0.53	825	0.59	875	0.66	918	0.73	959	0.79	1000	0.86	1039	0.92	1078	1.00	1116	1.09	1151	1.17

Continued

CFM	External Static Pressure (Inches of Water)									
	1.10		1.20		1.30		1.40		1.50	
	RPM	BHP	RPM	BHP	RPM	BHP	RPM	BHP	RPM	BHP
<b>1-HP Standard Motor &amp; Drive</b>										
800*	963	0.49	999	0.54	1034	0.59	1068	0.65	1101	0.70
960*	986	0.55	1023	0.61	1060	0.67	1095	0.73	1127	0.79
1120*	1012	0.63	1048	0.69	1084	0.75	1118	0.81	1151	0.88
1280	1041	0.72	1076	0.78	1110	0.84	1143	0.91	1176	0.98
1440	1074	0.83	1108	0.89	1141	0.96	1174	1.03	1205	1.10
1600	1109	0.95	1142	1.02	1175	1.09	1207	1.17	1236	1.24
1760	1147	1.10	1179	1.17	1211	1.25	1241	1.32	—	—
1920	1186	1.26	1218	1.34	1249	1.42	—	—	—	—

For Standard Evaporator Fan Speed (RPM), reference [Table 123](#).  
Notes: Data includes pressure drop due to standard filters and wet coils. No accessories or options are included in pressure drop data. Data does not include pressure drop due to reheat coil. Refer to [Table 128](#) to determine additional static pressure drop due to other options/accessories.  
1-HP Fan Motor Heat (MBH) = 2.829 x Fan BHP+.4024.  
Factory supplied motors, in commercial equipment, are definite purpose motors, specifically designed and tested to operate reliably and continuously at all cataloged conditions. Using the full horsepower range of our fan motors as shown in our tabular data will not result in nuisance tripping or premature motor failure. Our product's warranty will not be affected.  
Table includes Dehumidification (Hot Gas Reheat Option).  
\*Unit applications below 1280 CFM  
• Electric heaters restricted on applications below 1280 CFM.  
• Dehumidification (Hot Gas Reheat) or TXV with Froststat and Crank-case Heaters are required on applications below 1280 CFM.

<sup>(i)</sup> BAYLSDR007A required.

**Table 86. Belt Drive Evaporator Fan Performance 4 Tons 13 SEER THC043A3,4,W Horizontal Airflow**

CFM	External Static Pressure (Inches of Water)																			
	.10		.20		.30		.40		.50		.60		.70		.80		.90		1.00	
	RPM	BHP	RPM	BHP	RPM	BHP	RPM	BHP	RPM	BHP	RPM	BHP	RPM	BHP	RPM	BHP	RPM	BHP	RPM	BHP
<b>1-HP Standard Motor &amp; Low Static Drive Accessory Kit<sup>(i)</sup></b>										<b>1-HP Standard Motor &amp; Drive</b>										
800*	461	0.08	553	0.11	629	0.16	692	0.20	745	0.25	794	0.29	838	0.34	881	0.38	922	0.43	962	0.48
960*	509	0.11	600	0.16	672	0.20	736	0.25	791	0.30	841	0.36	887	0.42	927	0.47	966	0.52	1004	0.58
1120*	561	0.16	649	0.21	719	0.26	779	0.32	836	0.37	886	0.43	932	0.50	975	0.56	1014	0.63	1052	0.69
1280	617	0.21	696	0.27	767	0.34	826	0.40	879	0.46	930	0.52	976	0.59	1020	0.66	1060	0.73	1098	0.80
1440	674	0.29	745	0.35	815	0.42	874	0.49	925	0.56	974	0.63	1020	0.70	1064	0.77	1104	0.85	1142	0.92
1600	733	0.38	799	0.45	862	0.53	922	0.60	975	0.68	1020	0.75	1065	0.83	1107	0.91	1147	0.99	1186	1.07
1760	793	0.49	854	0.56	911	0.65	969	0.73	1023	0.82	1069	0.90	1112	0.98	1152	1.07	1191	1.15	1230	1.24
1920	853	0.62	911	0.70	964	0.79	1018	0.88	1069	0.97	1118	1.06	1161	1.15	1201	1.25	1239	1.34	1275	1.43

Continued

CFM	External Static Pressure (Inches of Water)									
	1.10		1.20		1.30		1.40		1.50	
	RPM	BHP	RPM	BHP	RPM	BHP	RPM	BHP	RPM	BHP
<b>1-HP Standard Motor &amp; Field Supplied High Static Drive<sup>(ii)</sup></b>										
800*	1001	0.54	1038	0.60	1072	0.65	1108	0.71	1142	0.78
960*	1040	0.63	1073	0.68	1108	0.75	1141	0.81	1175	0.88
1120*	1087	0.75	1119	0.81	1152	0.88	1183	0.94	1213	1.00
1280	1132	0.88	1167	0.95	1199	1.03	1231	1.10	1260	1.17
1440	1179	1.01	1213	1.09	1245	1.17	1277	1.26	1307	1.34
1600	1223	1.15	1258	1.24	1291	1.33	1322	1.42	—	—
1760	1267	1.33	1301	1.42	—	—	—	—	—	—
1920	—	—	—	—	—	—	—	—	—	—
<b>1-HP Standard Motor &amp; Field Supplied High Static Drive<sup>(iii)</sup></b>										

For Standard Evaporator Fan Speed (RPM), reference [Table 123](#).  
Notes: Data includes pressure drop due to standard filters and wet coils. No accessories or options are included in pressure drop data. Data does not include pressure drop due to reheat coil. Refer to [Table 128](#) to determine additional static pressure drop due to other options/accessories.  
1-HP Fan Motor Heat (MBH) = 2.829 x Fan BHP+.4024.  
Factory supplied motors, in commercial equipment, are definite purpose motors, specifically designed and tested to operate reliably and continuously at all cataloged conditions. Using the full horsepower range of our fan motors as shown in our tabular data will not result in nuisance tripping or premature motor failure. Our product's warranty will not be affected.  
Table includes Dehumidification (Hot Gas Reheat Option).  
\*Unit applications below 1280 CFM  
• Electric heaters restricted on applications below 1280 CFM.  
• Dehumidification (Hot Gas Reheat) or TXV with Froststat and Crank-case Heaters are required on applications below 1280 CFM.

<sup>(i)</sup> BAYLSDR007A required.

<sup>(ii)</sup> Field Supplied Fan Sheave AK41 required. Field Supplied Belt may be necessary.

<sup>(iii)</sup> Field Supplied Fan Sheave AK41 required. Field Supplied Belt may be necessary.

## Performance Data

*(4 Tons High Efficiency)*

**Table 87. Belt Drive Evaporator Fan Performance 4 Tons 13 SEER YHC043A3,4,W\*L,M Low & Medium Heat Downflow Airflow**

CFM	External Static Pressure (Inches of Water)																			
	.10		.20		.30		.40		.50		.60		.70		.80		.90		1.00	
	RPM	BHP	RPM	BHP	RPM	BHP	RPM	BHP	RPM	BHP	RPM	BHP	RPM	BHP	RPM	BHP	RPM	BHP	RPM	BHP
<b>1-HP Standard Motor &amp; Low Static Drive Accessory Kit<sup>(i)</sup></b>										<b>1-HP Standard Motor &amp; Drive</b>										
1280	614	0.22	675	0.26	733	0.31	787	0.37	834	0.42	878	0.48	919	0.53	959	0.59	997	0.65	1034	0.71
1440	676	0.30	731	0.34	784	0.39	835	0.46	883	0.52	925	0.58	965	0.64	1003	0.70	1039	0.76	1075	0.83
1600	739	0.40	789	0.45	838	0.50	885	0.56	931	0.63	973	0.70	1012	0.77	1049	0.84	1085	0.91	1118	0.97
1760	803	0.51	850	0.57	894	0.63	938	0.69	981	0.76	1021	0.83	1061	0.92	1097	0.99	1131	1.07	1164	1.14
1920	867	0.65	911	0.72	952	0.78	993	0.84	1033	0.91	1071	0.99	1110	1.07	1145	1.16	1180	1.25	1213	1.33

**Continued**

CFM	External Static Pressure (Inches of Water)									
	1.10		1.20		1.30		1.40		1.50	
	RPM	BHP	RPM	BHP	RPM	BHP	RPM	BHP	RPM	BHP
<b>1-HP Standard Motor &amp; Drive</b>										
1280	1069	0.77	1104	0.83	1138	0.90	1170	0.97	1203	1.04
1440	1109	0.89	1141	0.96	1175	1.03	1205	1.10	1236	1.17
1600	1151	1.04	1183	1.11	1215	1.19	1246	1.26	1275	1.33
1760	1197	1.21	1227	1.29	1258	1.36	1287	1.44	—	—
1920	1243	1.41	1274	1.49	—	—	—	—	—	—
<b>1-HP Standard Motor &amp; Field Supplied High Static Drive<sup>(ii)</sup></b>										

For Standard Evaporator Fan Speed (RPM), reference [Table 123](#).  
Notes: Data includes pressure drop due to standard filters and wet coils. No accessories or options are included in pressure drop data. Data does not include pressure drop due to reheat coil. Refer to [Table 128](#) to determine additional static pressure drop due to other options/accessories.  
1-HP Fan Motor Heat (MBH) = 2.829 x Fan BHP + .4024.  
Factory supplied motors, in commercial equipment, are definite purpose motors, specifically designed and tested to operate reliably and continuously at all cataloged conditions. Using the full horsepower range of our fan motors as shown in our tabular data will not result in nuisance tripping or premature motor failure. Our product's warranty will not be affected.

<sup>(i)</sup> Field Supplied Fan Sheave AK61 required. Field Supplied Belt may be necessary.

<sup>(ii)</sup> Field Supplied Fan Sheave AK41 required. Field Supplied Belt may be necessary.

**Table 88. Belt Drive Evaporator Fan Performance 4 Tons 13 SEER YHC043A3,4,W\*H High Heat Downflow Airflow**

CFM	External Static Pressure (Inches of Water)																			
	.10		.20		.30		.40		.50		.60		.70		.80		.90		1.00	
	RPM	BHP	RPM	BHP	RPM	BHP	RPM	BHP	RPM	BHP	RPM	BHP	RPM	BHP	RPM	BHP	RPM	BHP	RPM	BHP
<b>1-HP Standard Motor &amp; Field Supplied Low Static Drive<sup>(i)</sup></b>										<b>1-HP Standard Motor &amp; Drive</b>										
1280	627	0.23	688	0.27	745	0.32	797	0.38	844	0.43	887	0.49	928	0.54	967	0.60	1006	0.66	1042	0.72
1440	691	0.31	746	0.36	798	0.41	848	0.47	894	0.54	936	0.60	975	0.66	1012	0.72	1049	0.78	1085	0.85
1600	756	0.41	806	0.47	854	0.52	901	0.58	945	0.66	987	0.73	1025	0.79	1061	0.86	1096	0.93	1129	1.00
1760	822	0.54	868	0.60	912	0.65	955	0.71	997	0.79	1038	0.87	1076	0.95	1111	1.02	1145	1.10	1178	1.17
1920	889	0.69	931	0.75	972	0.81	1012	0.88	1051	0.95	1090	1.03	1127	1.11	1162	1.20	1196	1.29	1228	1.37

**Continued**

CFM	External Static Pressure (Inches of Water)									
	1.10		1.20		1.30		1.40		1.50	
	RPM	BHP	RPM	BHP	RPM	BHP	RPM	BHP	RPM	BHP
<b>1-HP Standard Motor &amp; Drive</b>										
1280	1077	0.78	1112	0.85	1145	0.91	1178	0.98	1210	1.05
1440	1118	0.91	1150	0.98	1183	1.05	1214	1.12	1244	1.19
1600	1162	1.06	1193	1.13	1225	1.21	1255	1.28	1285	1.36
1760	1208	1.24	1239	1.32	1268	1.39	1297	1.47	—	—
1920	1258	1.45	—	—	—	—	—	—	—	—
<b>1-HP Standard Motor &amp; Field Supplied High Static Drive<sup>(ii)</sup></b>										

For Standard Evaporator Fan Speed (RPM), reference [Table 123](#).  
Notes: Data includes pressure drop due to standard filters and wet coils. No accessories or options are included in pressure drop data. Data does not include pressure drop due to reheat coil. Refer to [Table 128](#) to determine additional static pressure drop due to other options/accessories.  
1-HP Fan Motor Heat (MBH) = 2.829 x Fan BHP + .4024.  
Factory supplied motors, in commercial equipment, are definite purpose motors, specifically designed and tested to operate reliably and continuously at all cataloged conditions. Using the full horsepower range of our fan motors as shown in our tabular data will not result in nuisance tripping or premature motor failure. Our product's warranty will not be affected.

<sup>(i)</sup> Field Supplied Fan Sheave AK61 required. Field Supplied Belt may be necessary.

<sup>(ii)</sup> Field Supplied Fan Sheave AK41 required. Field Supplied Belt may be necessary.

## Performance Data

*(4 Tons High Efficiency)*

**Table 89. Belt Drive Evaporator Fan Performance 4 Tons 13 SEER YHC043A3,4,W\*L,M Low & Medium Heat Horizontal Airflow**

CFM	External Static Pressure (Inches of Water)																			
	.10		.20		.30		.40		.50		.60		.70		.80		.90		1.00	
	RPM	BHP	RPM	BHP	RPM	BHP	RPM	BHP	RPM	BHP	RPM	BHP	RPM	BHP	RPM	BHP	RPM	BHP	RPM	BHP
<b>1-HP Standard Motor &amp; Field Supplied Low Static Drive<sup>(i)</sup></b>										<b>1-HP Standard Motor &amp; Drive</b>										
1280	681	0.26	755	0.32	816	0.38	870	0.45	921	0.51	968	0.58	1013	0.65	1053	0.72	1091	0.79	1127	0.86
1440	748	0.36	817	0.43	876	0.49	927	0.56	976	0.63	1022	0.70	1065	0.78	1106	0.85	1144	0.93	1180	1.01
1600	816	0.47	879	0.55	937	0.62	987	0.70	1033	0.78	1076	0.85	1119	0.93	1158	1.01	1197	1.10	1233	1.18
1760	885	0.61	943	0.69	999	0.78	1049	0.86	1093	0.94	1135	1.03	1174	1.11	1213	1.20	1250	1.29	1286	1.38
1920	956	0.77	1009	0.86	1062	0.96	1110	1.05	1154	1.14	1195	1.23	1232	1.32	1269	1.41	1304	1.50	—	—
<b>1-HP Standard Motor &amp; Field Supplied High Static Drive<sup>(ii)</sup></b>																				
<b>Continued</b>																				
CFM	External Static Pressure (Inches of Water)																			
	1.10		1.20		1.30		1.40		1.50											
	RPM	BHP	RPM	BHP	RPM	BHP	RPM	BHP	RPM	BHP										
<b>1-HP Standard Motor &amp; Drive</b>																				
1280	1162	0.94	1193	1.01	1225	1.09	1255	1.16	1284	1.23										
1440	1214	1.09	1247	1.18	1278	1.26	1309	1.35	1337	1.43										
1600	1268	1.27	1300	1.35	1332	1.45	—	—	—	—										
1760	1320	1.47	—	—	—	—	—	—	—	—										
1920	—	—	—	—	—	—	—	—	—	—										
<b>1-HP Standard Motor &amp; Field Supplied High Static Drive<sup>(iii)</sup></b>																				

For Standard Evaporator Fan Speed (RPM), reference [Table 123](#).  
 Notes: Data includes pressure drop due to standard filters and wet coils. No accessories or options are included in pressure drop data. Data does not include pressure drop due to reheat coil. Refer to [Table 128](#) to determine additional static pressure drop due to other options/accessories.  
 1-HP Fan Motor Heat (MBH) = 2.829 x Fan BHP+.4024.  
 Factory supplied motors, in commercial equipment, are definite purpose motors, specifically designed and tested to operate reliably and continuously at all cataloged conditions. Using the full horsepower range of our fan motors as shown in our tabular data will not result in nuisance tripping or premature motor failure. Our product's warranty will not be affected.

<sup>(i)</sup> Field Supplied Fan Sheave AK61 required. Field Supplied Belt may be necessary.  
<sup>(ii)</sup> Field Supplied Fan Sheave AK41 required. Field Supplied Belt may be necessary.  
<sup>(iii)</sup> Field Supplied Fan Sheave AK41 required. Field Supplied Belt may be necessary.

**Table 90. Belt Drive Evaporator Fan Performance 4 Tons 13 SEER YHC043A3,4,W\*H High Heat Horizontal Airflow**

CFM	External Static Pressure (Inches of Water)																			
	.10		.20		.30		.40		.50		.60		.70		.80		.90		1.00	
	RPM	BHP	RPM	BHP	RPM	BHP	RPM	BHP	RPM	BHP	RPM	BHP	RPM	BHP	RPM	BHP	RPM	BHP	RPM	BHP
<b>1-HP Standard Motor &amp; Field Supplied Low Static Drive<sup>(i)</sup></b>										<b>1-HP Standard Motor &amp; Drive</b>										
1280	698	0.28	769	0.34	828	0.40	881	0.46	932	0.52	978	0.59	1021	0.66	1061	0.73	1099	0.81	1134	0.88
1440	767	0.37	834	0.44	890	0.51	941	0.58	988	0.65	1034	0.72	1077	0.80	1116	0.87	1153	0.95	1190	1.03
1600	837	0.50	899	0.57	955	0.65	1003	0.72	1048	0.80	1091	0.88	1132	0.96	1171	1.04	1209	1.12	1245	1.21
1760	908	0.64	966	0.73	1020	0.81	1067	0.89	1110	0.98	1151	1.06	1190	1.15	1228	1.23	1264	1.32	1300	1.41
1920	981	0.82	1035	0.91	1085	1.00	1133	1.09	1174	1.18	1213	1.27	1250	1.37	1286	1.46	—	—	—	—
<b>1-HP Standard Motor &amp; Field Supplied High Static Drive<sup>(ii)</sup></b>																				
<b>Continued</b>																				
CFM	External Static Pressure (Inches of Water)																			
	1.10		1.20		1.30		1.40		1.50											
	RPM	BHP	RPM	BHP	RPM	BHP	RPM	BHP	RPM	BHP										
<b>1-HP Standard Motor &amp; Drive</b>																				
1280	1169	0.96	1201	1.03	1231	1.10	1262	1.17	1290	1.24										
1440	1222	1.11	1256	1.20	1286	1.28	1317	1.37	1346	1.45										
1600	1278	1.29	1311	1.38	1342	1.48	—	—	—	—										
1760	—	—	—	—	—	—	—	—	—	—										
1920	—	—	—	—	—	—	—	—	—	—										
<b>1-HP Standard Motor &amp; Field Supplied High Static Drive<sup>(iii)</sup></b>																				

For Standard Evaporator Fan Speed (RPM), reference [Table 123](#).  
 Notes: Data includes pressure drop due to standard filters and wet coils. No accessories or options are included in pressure drop data. Data does not include pressure drop due to reheat coil. Refer to [Table 128](#) to determine additional static pressure drop due to other options/accessories.  
 1-HP Fan Motor Heat (MBH) = 2.829 x Fan BHP+.4024.  
 Factory supplied motors, in commercial equipment, are definite purpose motors, specifically designed and tested to operate reliably and continuously at all cataloged conditions. Using the full horsepower range of our fan motors as shown in our tabular data will not result in nuisance tripping or premature motor failure. Our product's warranty will not be affected.

<sup>(i)</sup> Field Supplied Fan Sheave AK61 required. Field Supplied Belt may be necessary.  
<sup>(ii)</sup> Field Supplied Fan Sheave AK41 required. Field Supplied Belt may be necessary.  
<sup>(iii)</sup> Field Supplied Fan Sheave AK41 required. Field Supplied Belt may be necessary.

## Performance Data

*(5 Tons High Efficiency)*

**Table 91. Belt Drive Evaporator Fan Performance 5 Tons 13 SEER THC063A3,4,W Downflow Airflow**

CFM	External Static Pressure (Inches of Water)																			
	.10		.20		.30		.40		.50		.60		.70		.80		.90		1.00	
	RPM	BHP	RPM	BHP	RPM	BHP	RPM	BHP	RPM	BHP	RPM	BHP	RPM	BHP	RPM	BHP	RPM	BHP	RPM	BHP
	<b>1-HP Standard Motor &amp; Low Static Drive Accessory Kit<sup>(1)</sup></b>															<b>1-HP Standard Motor &amp; Drive</b>				
1000*	—	—	537	0.13	608	0.17	667	0.21	721	0.25	770	0.30	817	0.35	861	0.39	905	0.45	944	0.50
1200*	517	0.15	588	0.19	652	0.23	712	0.28	764	0.33	811	0.38	856	0.43	898	0.48	939	0.54	978	0.59
1400*	576	0.21	645	0.26	702	0.31	756	0.36	808	0.41	856	0.48	900	0.54	941	0.59	979	0.65	1017	0.71
1600	640	0.31	703	0.36	757	0.41	806	0.47	854	0.52	899	0.58	944	0.65	985	0.73	1023	0.79	1060	0.86
1800	706	0.42	760	0.47	815	0.54	861	0.60	904	0.66	947	0.72	988	0.78	1028	0.86	1067	0.94	1104	1.02
2000	773	0.57	821	0.62	873	0.69	918	0.76	958	0.83	998	0.90	1036	0.96	1073	1.02	1111	1.10	1147	1.19
2200	840	0.75	885	0.80	930	0.87	977	0.95	1016	1.03	1053	1.10	1089	1.17	1124	1.24	1158	1.31	1191	1.39
2400	909	0.96	950	1.02	990	1.08	1034	1.16	1074	1.25	1110	1.00	1143	1.42	1177	1.50	—	—	—	—

**Continued**

CFM	External Static Pressure (Inches of Water)									
	1.10		1.20		1.30		1.40		1.50	
	RPM	BHP	RPM	BHP	RPM	BHP	RPM	BHP	RPM	BHP
	<b>1-HP Standard Motor &amp; Drive</b>									
1000*	985	0.56	1021	0.62	1058	0.68	1093	0.74	1126	0.80
1200*	1015	0.65	1051	0.71	1086	0.77	1120	0.84	1154	0.91
1400*	1052	0.77	1088	0.84	1121	0.90	1153	0.97	1185	1.04
1600	1093	0.92	1126	0.99	1160	1.06	1190	1.13	1222	1.20
1800	1138	1.10	1171	1.17	1203	1.25	1232	1.32	1262	1.39
2000	1182	1.28	1215	1.37	1246	1.46	—	—	—	—
2200	1226	1.48	—	—	—	—	—	—	—	—
2400	—	—	—	—	—	—	—	—	—	—

For Standard Evaporator Fan Speed (RPM), reference [Table 123](#).  
 Notes: Data includes pressure drop due to standard filters and wet coils. No accessories or options are included in pressure drop data. Data does not include pressure drop due to reheat coil. Refer to [Table 128](#) to determine additional static pressure drop due to other options/accessories.  
 1-HP Fan Motor Heat (MBH) = 2.829 x Fan BHP+.4024.  
 Factory supplied motors, in commercial equipment, are definite purpose motors, specifically designed and tested to operate reliably and continuously at all cataloged conditions. Using the full horsepower range of our fan motors as shown in our tabular data will not result in nuisance tripping or premature motor failure. Our product's warranty will not be affected.  
 Table includes Dehumidification (Hot Gas Reheat Option).  
 \*Unit applications below 1600 CFM  
 • Electric heaters restricted on applications below 1600 CFM.  
 • Dehumidification (Hot Gas Reheat) or TXV with Froststat and Crank-case Heaters are required on applications below 1600 CFM.

<sup>(1)</sup> BAYLSDR007A required.

## Performance Data

*(5 Tons High Efficiency)*

**Table 92. Belt Drive Evaporator Fan Performance 5 Tons 13 SEER THC063A3,4,W Horizontal Airflow**

CFM	External Static Pressure (Inches of Water)																			
	.10		.20		.30		.40		.50		.60		.70		.80		.90		1.00	
	RPM	BHP	RPM	BHP	RPM	BHP	RPM	BHP	RPM	BHP	RPM	BHP	RPM	BHP	RPM	BHP	RPM	BHP	RPM	BHP
<b>1-HP Standard Motor &amp; Low Static Drive Accessory Kit<sup>(1)</sup></b>										<b>1-HP Standard Motor &amp; Drive</b>										
1000*	507	0.11	599	0.16	671	0.21	735	0.26	792	0.31	843	0.37	889	0.42	931	0.48	971	0.54	1007	0.59
1200*	570	0.17	654	0.23	727	0.28	787	0.34	843	0.40	895	0.46	942	0.52	986	0.59	1026	0.66	1064	0.73
1400*	638	0.25	711	0.31	782	0.38	844	0.44	896	0.51	946	0.58	993	0.65	1037	0.72	1078	0.79	1117	0.86
1600	707	0.35	774	0.42	837	0.50	898	0.57	953	0.65	1001	0.72	1045	0.80	1087	0.87	1129	0.95	1168	1.03
1800	778	0.48	840	0.56	897	0.64	953	0.72	1008	0.81	1058	0.89	1102	0.98	1143	1.06	1181	1.15	1219	1.23
2000	850	0.65	908	0.73	961	0.81	1012	0.90	1062	1.00	1111	1.09	1157	1.19	1198	1.28	1237	1.37	1274	1.47
2200	923	0.84	978	0.93	1028	1.02	1075	1.12	1120	1.22	1166	1.32	1211	1.43	—	—	—	—	—	—
2400	997	1.07	1049	1.17	1096	1.27	1140	1.37	1183	1.48	—	—	—	—	—	—	—	—	—	—

**Continued**

CFM	External Static Pressure (Inches of Water)									
	1.10		1.20		1.30		1.40		1.50	
	RPM	BHP	RPM	BHP	RPM	BHP	RPM	BHP	RPM	BHP
<b>1-HP Standard Motor &amp; Drive</b>										
1000*	1042	0.65	1078	0.70	1110	0.76	1142	0.82	1175	0.89
1200*	1099	0.80	1133	0.86	1166	0.93	1197	0.99	1227	1.06
1400*	1153	0.94	1188	1.02	1221	1.10	1253	1.18	1284	1.27
1600	1206	1.12	1241	1.20	1275	1.28	1306	1.37	1338	1.46
1800	1256	1.32	1291	1.41	1326	1.50	—	—	—	—
2000	—	—	—	—	—	—	—	—	—	—
2200	—	—	—	—	—	—	—	—	—	—
2400	—	—	—	—	—	—	—	—	—	—

For Standard Evaporator Fan Speed (RPM), reference [Table 123](#).  
 Notes: Data includes pressure drop due to standard filters and wet coils. No accessories or options are included in pressure drop data. Data does not include pressure drop due to reheat coil. Refer to [Table 128](#) to determine additional static pressure drop due to other options/accessories.

1-HP Fan Motor Heat (MBH) = 2.829 x Fan BHP+.4024.  
 Factory supplied motors, in commercial equipment, are definite purpose motors, specifically designed and tested to operate reliably and continuously at all cataloged conditions. Using the full horsepower range of our fan motors as shown in our tabular data will not result in nuisance tripping or premature motor failure. Our product's warranty will not be affected.

Table includes Dehumidification (Hot Gas Reheat Option).

\*Unit applications below 1600 CFM

- Electric heaters restricted on applications below 1600 CFM.
- Dehumidification (Hot Gas Reheat) or TXV with Froststat and Crank-case Heaters are required on applications below 1600 CFM.

<sup>(1)</sup> BAYLSDR008A required.

## Performance Data

*(5 Tons High Efficiency)*

**Table 93. Belt Drive Evaporator Fan Performance 5 Tons 13 SEER YHC063A3,4,W\*L,M Low & Medium Heat Downflow Airflow**

CFM	External Static Pressure (Inches of Water)																			
	.10		.20		.30		.40		.50		.60		.70		.80		.90		1.00	
	RPM	BHP	RPM	BHP	RPM	BHP	RPM	BHP	RPM	BHP	RPM	BHP	RPM	BHP	RPM	BHP	RPM	BHP	RPM	BHP
<b>1-HP Standard Motor &amp; Field Supplied Low Static Drive<sup>(1)</sup></b>										<b>1-HP Standard Motor &amp; Drive</b>										
1600	704	0.36	757	0.41	806	0.47	853	0.52	899	0.58	942	0.65	984	0.72	1021	0.79	1058	0.85	1092	0.92
1800	777	0.49	828	0.56	872	0.62	915	0.67	957	0.73	998	0.80	1038	0.88	1076	0.96	1112	1.04	1146	1.11
2000	851	0.66	900	0.73	942	0.80	981	0.87	1019	0.93	1057	0.99	1094	1.07	1130	1.15	1165	1.24	1199	1.33
2200	927	0.86	973	0.94	1012	1.02	1049	1.09	1084	1.17	1119	1.23	1153	1.30	1188	1.38	1220	1.46	—	—
2400	1003	1.10	1045	1.19	1084	1.28	1119	1.36	1152	1.44	—	—	—	—	—	—	—	—	—	—

**Continued**

CFM	External Static Pressure (Inches of Water)									
	1.10		1.20		1.30		1.40		1.50	
	RPM	BHP	RPM	BHP	RPM	BHP	RPM	BHP	RPM	BHP
<b>1-HP Standard Motor &amp; Drive</b>										
1600	1125	0.98	1158	1.06	1190	1.13	1220	1.20	1250	1.27
1800	1178	1.19	1209	1.26	1239	1.33	1269	1.41	1296	1.48
2000	1232	1.42	1263	1.50	—	—	—	—	—	—
2200	—	—	—	—	—	—	—	—	—	—
2400	—	—	—	—	—	—	—	—	—	—

For Standard Evaporator Fan Speed (RPM), reference [Table 123](#).  
Notes: Data includes pressure drop due to standard filters and wet coils. No accessories or options are included in pressure drop data. Data does not include pressure drop due to reheat coil. Refer to [Table 128](#) to determine additional static pressure drop due to other options/accessories.  
1-HP Fan Motor Heat (MBH) = 2.829 x Fan BHP + .4024.  
Factory supplied motors, in commercial equipment, are definite purpose motors, specifically designed and tested to operate reliably and continuously at all cataloged conditions. Using the full horsepower range of our fan motors as shown in our tabular data will not result in nuisance tripping or premature motor failure. Our product's warranty will not be affected.

<sup>(1)</sup> Field Supplied Fan Sheave AK61 required. Field Supplied Belt may be necessary.

**Table 94. Belt Drive Evaporator Fan Performance 5 Tons 13 SEER YHC063A3,4,W\*H High Heat Downflow Airflow**

CFM	External Static Pressure (Inches of Water)																			
	.10		.20		.30		.40		.50		.60		.70		.80		.90		1.00	
	RPM	BHP	RPM	BHP	RPM	BHP	RPM	BHP	RPM	BHP	RPM	BHP	RPM	BHP	RPM	BHP	RPM	BHP	RPM	BHP
<b>1-HP Standard Motor &amp; Field Supplied Low Static Drive<sup>(1)</sup></b>										<b>1-HP Standard Motor &amp; Drive</b>										
1600	723	0.38	774	0.43	822	0.48	869	0.54	914	0.60	957	0.68	997	0.75	1035	0.81	1070	0.88	1104	0.94
1800	801	0.52	847	0.58	891	0.64	933	0.70	975	0.76	1015	0.83	1054	0.91	1091	0.99	1126	1.07	1160	1.15
2000	878	0.70	922	0.77	962	0.84	1001	0.90	1039	0.96	1076	1.03	1113	1.11	1149	1.20	1183	1.28	1217	1.38
2200	957	0.91	999	0.99	1036	1.07	1072	1.14	1107	1.21	1142	1.28	1176	1.35	1209	1.43	—	—	—	—
2400	1036	1.17	1076	1.26	1111	1.34	1144	1.42	1177	1.50	—	—	—	—	—	—	—	—	—	—

**Continued**

CFM	External Static Pressure (Inches of Water)									
	1.10		1.20		1.30		1.40		1.50	
	RPM	BHP	RPM	BHP	RPM	BHP	RPM	BHP	RPM	BHP
<b>1-HP Standard Motor &amp; Drive</b>										
1600	1137	1.01	1168	1.08	1199	1.15	1230	1.22	1260	1.29
1800	1191	1.22	1222	1.29	1252	1.37	1281	1.44	1310	1.50
2000	1248	1.46	—	—	—	—	—	—	—	—
2200	—	—	—	—	—	—	—	—	—	—
2400	—	—	—	—	—	—	—	—	—	—

For Standard Evaporator Fan Speed (RPM), reference [Table 123](#).  
Notes: Data includes pressure drop due to standard filters and wet coils. No accessories or options are included in pressure drop data. Data does not include pressure drop due to reheat coil. Refer to [Table 128](#) to determine additional static pressure drop due to other options/accessories.  
1-HP Fan Motor Heat (MBH) = 2.829 x Fan BHP + .4024.  
Factory supplied motors, in commercial equipment, are definite purpose motors, specifically designed and tested to operate reliably and continuously at all cataloged conditions. Using the full horsepower range of our fan motors as shown in our tabular data will not result in nuisance tripping or premature motor failure. Our product's warranty will not be affected.

<sup>(1)</sup> Field Supplied Fan Sheave AK61 required. Field Supplied Belt may be necessary.

## Performance Data

*(5 Tons High Efficiency)*

**Table 95. Belt Drive Evaporator Fan Performance 5 Tons 13 SEER YHC063A3,4,W\*L,M Low & Medium Heat Horizontal Airflow**

CFM	External Static Pressure (Inches of Water)																			
	.10		.20		.30		.40		.50		.60		.70		.80		.90		1.00	
	RPM	BHP	RPM	BHP	RPM	BHP	RPM	BHP	RPM	BHP	RPM	BHP	RPM	BHP	RPM	BHP	RPM	BHP	RPM	BHP
<b>1-HP Standard Motor &amp; Field Supplied Low Static Drive<sup>(1)</sup></b>										<b>1-HP Standard Motor &amp; Drive</b>										
1600	775	0.42	837	0.50	898	0.57	952	0.65	1000	0.72	1044	0.79	1086	0.87	1127	0.95	1166	1.03	1203	1.11
1800	856	0.58	912	0.66	967	0.74	1020	0.83	1069	0.91	1112	1.00	1152	1.08	1189	1.16	1227	1.25	1263	1.34
2000	939	0.77	990	0.86	1040	0.96	1089	1.05	1136	1.14	1180	1.24	1219	1.33	1256	1.42	1292	1.50	—	—
2200	1023	1.01	1070	1.11	1115	1.21	1160	1.31	1205	1.41	—	—	—	—	—	—	—	—	—	—
2400	1108	1.29	1151	1.39	1193	1.50	—	—	—	—	—	—	—	—	—	—	—	—	—	—

**Continued**

CFM	External Static Pressure (Inches of Water)							
	1.10		1.20		1.30		1.40	
	RPM	BHP	RPM	BHP	RPM	BHP	RPM	BHP
<b>1-HP Standard Motor &amp; Drive</b>								
1600	1239	1.19	1272	1.28	1304	1.37	1336	1.46
1800	1299	1.43	—	—	—	—	—	—
2000	—	—	—	—	—	—	—	—
2200	—	—	—	—	—	—	—	—
2400	—	—	—	—	—	—	—	—

For Standard Evaporator Fan Speed (RPM), reference [Table 123](#).  
 Notes: Data includes pressure drop due to standard filters and wet coils. No accessories or options are included in pressure drop data. Data does not include pressure drop due to reheat coil. Refer to [Table 128](#) to determine additional static pressure drop due to other options/accessories.  
 1-HP Fan Motor Heat (MBH) = 2.829 x Fan BHP + .4024.  
 Factory supplied motors, in commercial equipment, are definite purpose motors, specifically designed and tested to operate reliably and continuously at all cataloged conditions. Using the full horsepower range of our fan motors as shown in our tabular data will not result in nuisance tripping or premature motor failure. Our product's warranty will not be affected.

<sup>(1)</sup> Field Supplied Fan Sheave AK61 required. Field Supplied Belt may be necessary.

**Table 96. Belt Drive Evaporator Fan Performance 5 Tons 13 SEER YHC063A3,4,W\*H High Heat Horizontal Airflow**

CFM	External Static Pressure (Inches of Water)																			
	.10		.20		.30		.40		.50		.60		.70		.80		.90		1.00	
	RPM	BHP	RPM	BHP	RPM	BHP	RPM	BHP	RPM	BHP	RPM	BHP	RPM	BHP	RPM	BHP	RPM	BHP	RPM	BHP
<b>1-HP Standard Motor &amp; Field Supplied Low Static Drive<sup>(1)</sup></b>										<b>1-HP Standard Motor &amp; Drive</b>										
1600	796	0.45	858	0.52	917	0.60	969	0.67	1015	0.75	1059	0.82	1100	0.90	1141	0.98	1178	1.06	1216	1.14
1800	881	0.61	935	0.70	991	0.78	1042	0.87	1087	0.95	1129	1.03	1168	1.12	1206	1.20	1244	1.29	1279	1.38
2000	967	0.82	1016	0.91	1066	1.01	1115	1.10	1160	1.19	1201	1.28	1239	1.38	1275	1.47	—	—	—	—
2200	1054	1.07	1099	1.17	1144	1.27	1189	1.38	1233	1.48	—	—	—	—	—	—	—	—	—	—
2400	1141	1.37	1183	1.48	—	—	—	—	—	—	—	—	—	—	—	—	—	—	—	—

**Continued**

CFM	External Static Pressure (Inches of Water)							
	1.10		1.20		1.30		1.40	
	RPM	BHP	RPM	BHP	RPM	BHP	RPM	BHP
<b>1-HP Standard Motor &amp; Drive</b>								
1600	1251	1.22	1283	1.31	1315	1.40	1345	1.49
1800	1313	1.47	—	—	—	—	—	—
2000	—	—	—	—	—	—	—	—
2200	—	—	—	—	—	—	—	—
2400	—	—	—	—	—	—	—	—

For Standard Evaporator Fan Speed (RPM), reference [Table 123](#).  
 Notes: Data includes pressure drop due to standard filters and wet coils. No accessories or options are included in pressure drop data. Data does not include pressure drop due to reheat coil. Refer to [Table 128](#) to determine additional static pressure drop due to other options/accessories.  
 1-HP Fan Motor Heat (MBH) = 2.829 x Fan BHP + .4024.  
 Factory supplied motors, in commercial equipment, are definite purpose motors, specifically designed and tested to operate reliably and continuously at all cataloged conditions. Using the full horsepower range of our fan motors as shown in our tabular data will not result in nuisance tripping or premature motor failure. Our product's warranty will not be affected.

<sup>(1)</sup> Field Supplied Fan Sheave AK61 required. Field Supplied Belt may be necessary.



## Performance Data

*(6 Tons High Efficiency)*

**Table 97. Belt Drive Evaporator Fan Performance 6 Tons with Electric Heat THC072A3,4,W\* Standard Refrigeration System Downflow Airflow**

CFM	External Static Pressure (Inches of Water)																			
	.10		.20		.30		.40		.50		.60		.70		.80		.90		1.00	
	RPM	BHP	RPM	BHP	RPM	BHP	RPM	BHP	RPM	BHP	RPM	BHP	RPM	BHP	RPM	BHP	RPM	BHP	RPM	BHP
<b>1-HP Standard Motor &amp; Field Supplied Low Static Drive<sup>(i)</sup></b>										<b>1-HP Standard Motor &amp; Drive</b>										
1920	—	—	—	—	588	0.35	643	0.43	693	0.50	738	0.57	782	0.65	823	0.73	862	0.81	900	0.89
2160	—	—	564	0.37	618	0.44	672	0.52	721	0.60	765	0.68	806	0.76	847	0.85	885	0.93	922	1.02
2400	—	—	602	0.47	652	0.54	701	0.63	750	0.72	794	0.81	834	0.90	873	0.98	909	1.08	945	1.17
2640	589	0.50	642	0.59	690	0.67	734	0.76	779	0.85	822	0.95	864	1.05	901	1.15	936	1.24	971	1.34
2880	634	0.63	682	0.74	728	0.82	770	0.91	810	1.01	851	1.11	892	1.22	930	1.33	965	1.44	999	1.54

Continued

CFM	External Static Pressure (Inches of Water)																			
	1.10		1.20		1.30		1.40		1.50		1.60		1.70		1.80		1.90		2.00	
	RPM	BHP	RPM	BHP	RPM	BHP	RPM	BHP	RPM	BHP	RPM	BHP	RPM	BHP	RPM	BHP	RPM	BHP	RPM	BHP
<b>1-HP Standard Motor &amp; Drive</b>										<b>1-HP Standard Motor &amp; High Static Drive Kit (or 2-HP Oversized Motor &amp; Drive)</b>										
1920	937	0.98	971	1.06	1004	1.14	1037	1.22	1068	1.30	1097	1.38	1127	1.47	1154	1.55	1182	1.64	1210	1.74
2160	957	1.12	991	1.21	1024	1.30	1057	1.40	1087	1.49	1117	1.58	1146	1.67	1174	1.76	1201	1.85	1227	1.95
2400	980	1.27	1013	1.37	1046	1.47	1076	1.57	1106	1.68	1137	1.78	1166	1.89	1194	1.99	1220	2.08	1248	2.19
2640	1004	1.44	1036	1.55	1067	1.65	1098	1.77	1129	1.88	1158	1.99	1185	2.10	1214	2.22	—	—	—	—
2880	1030	1.64	1061	1.75	1092	1.86	1123	1.98	1151	2.09	1181	2.22	—	—	—	—	—	—	—	—

**2-HP Oversized Motor & Drive**

For Standard Evaporator Fan Speed (RPM), reference [Table 123](#). Notes: Data includes pressure drop due to standard filters and wet coils. No accessories or options are included in pressure drop data. Refer to [Table 128](#) to determine additional static pressure drop due to other options/accessories. 1-HP Fan Motor Heat (MBH) = 2.829 x Fan BHP + .4024. 2-HP Fan Motor Heat (MBH) = 3.000 x Fan BHP + .5000. Factory supplied motors, in commercial equipment, are definite purpose motors, specifically designed and tested to operate reliably and continuously at all cataloged conditions. Using the full horsepower range of our fan motors as shown in our tabular data will not result in nuisance tripping or premature motor failure. Our product's warranty will not be affected.

<sup>(i)</sup> Field Supplied Fan Sheave AK84 and Belt AX34 required.

**Table 98. Belt Drive Evaporator Fan Performance 6 Tons with Electric Heat THC072A3,4,W Standard Refrigeration System Horizontal Airflow**

CFM	External Static Pressure (Inches of Water)																			
	.10		.20		.30		.40		.50		.60		.70		.80		.90		1.00	
	RPM	BHP	RPM	BHP	RPM	BHP	RPM	BHP	RPM	BHP	RPM	BHP	RPM	BHP	RPM	BHP	RPM	BHP	RPM	BHP
<b>1-HP Standard Motor &amp; Field Supplied Low Static Drive<sup>(i)</sup></b>										<b>1-HP Standard Motor &amp; Drive</b>										
1920	—	—	580	0.33	641	0.41	692	0.47	738	0.54	783	0.63	827	0.71	870	0.79	912	0.88	951	0.96
2160	578	0.37	623	0.43	679	0.51	731	0.59	775	0.67	817	0.74	857	0.83	896	0.93	935	1.02	974	1.12
2400	633	0.49	673	0.56	718	0.63	769	0.72	814	0.82	855	0.90	893	0.98	929	1.08	965	1.18	999	1.29
2640	688	0.64	725	0.71	762	0.79	808	0.87	853	0.98	894	1.09	931	1.17	966	1.26	1000	1.36	1032	1.47 <sup>(ii)</sup>
2880	743	0.81	778	0.90	811	0.98	848	1.06	891	1.16	932	1.28	970	1.40	1004	1.49	1037	1.59	1068	1.69

**1-HP Standard Motor & High Static Drive Kit (or 2-HP Oversized Motor)**

Continued

CFM	External Static Pressure (Inches of Water)																			
	1.10		1.20		1.30		1.40		1.50		1.60		1.70		1.80		1.90		2.00	
	RPM	BHP	RPM	BHP	RPM	BHP	RPM	BHP	RPM	BHP	RPM	BHP	RPM	BHP	RPM	BHP	RPM	BHP	RPM	BHP
<b>1-HP Standard Motor &amp; Drive</b>										<b>1-HP Standard Motor &amp; High Static Drive Kit (or 2-HP Oversized Motor &amp; Drive)</b>										
1920	990	1.05	1026	1.14	1062	1.24	1096	1.33	1130	1.43	1160	1.52	1190	1.61	1218	1.71	1247	1.80	1273	1.90
2160	1010	1.21	1047	1.31	1082	1.40	1116	1.50	1150	1.61	1182	1.71	1211	1.81	1242	1.92	1271	2.03	1298	2.14
2400	1035	1.39	1070	1.50	1104	1.60	1137	1.70	1168	1.81	1201	1.92	1232	2.03	1261	2.14	1291	2.26	—	—
2640	1065	1.59	1097	1.71	1129	1.82	1161	1.93	1192	2.05	1223	2.16	1252	2.27	—	—	—	—	—	—
2880	1099	1.80	1130	1.93	1159	2.05	1188	2.18	1217	2.30	—	—	—	—	—	—	—	—	—	—

**2-HP Oversized Motor & Drive**

**2-HP Oversized Motor & Field Supplied Drive<sup>(iii)</sup>**

For Standard Evaporator Fan Speed (RPM), reference [Table 123](#). Notes: Data includes pressure drop due to standard filters and wet coils. No accessories or options are included in pressure drop data. Refer to [Table 128](#) to determine additional static pressure drop due to other options/accessories. 1-HP Fan Motor Heat (MBH) = 2.829 x Fan BHP + .4024. 2-HP Fan Motor Heat (MBH) = 3.000 x Fan BHP + .5000. Factory supplied motors, in commercial equipment, are definite purpose motors, specifically designed and tested to operate reliably and continuously at all cataloged conditions. Using the full horsepower range of our fan motors as shown in our tabular data will not result in nuisance tripping or premature motor failure. Our product's warranty will not be affected.

<sup>(i)</sup> Field Supplied Fan Sheave AK84 and Belt AX34 required.

<sup>(ii)</sup> 2-HP Oversized Motor & Field Supplied Drive

<sup>(iii)</sup> Field Supplied Fan Sheave AK54 and Belt AX30.

## Performance Data

*(6 Tons High Efficiency)*

**Table 99. Belt Drive Evaporator Fan Performance 6 Tons with Gas Heat YHC072A3,4,W\*L,M Downflow Airflow**

External Static Pressure (Inches of Water)																					
CFM	.10		.20		.30		.40		.50		.60		.70		.80		.90		1.00		
	RPM	BHP	RPM	BHP	RPM	BHP	RPM	BHP	RPM	BHP	RPM	BHP	RPM	BHP	RPM	BHP	RPM	BHP	RPM	BHP	
<b>1-HP Standard Motor &amp; Field Supplied Low Static Drive<sup>(i)</sup></b>											<b>1-HP Standard Motor &amp; Drive</b>										
1920	—	—	—	—	597	0.37	652	0.44	700	0.51	745	0.58	788	0.66	829	0.74	869	0.82	906	0.91	
2160	—	—	575	0.38	629	0.46	683	0.54	730	0.62	774	0.70	815	0.78	854	0.86	893	0.95	929	1.04	
2400	561	0.41	615	0.49	664	0.57	714	0.65	762	0.74	805	0.83	844	0.92	882	1.01	918	1.10	954	1.20	
2640	606	0.53	657	0.62	703	0.70	747	0.79	792	0.88	835	0.98	875	1.08	912	1.18	947	1.27	980	1.37	
2880	651	0.67	699	0.77	743	0.85	785	0.94	825	1.05	867	1.15	906	1.26	943	1.37	978	1.47	1010	1.58	
											<b>2-HP Oversized Motor &amp; Drive</b>										

Continued

External Static Pressure (Inches of Water)																					
CFM	1.10		1.20		1.30		1.40		1.50		1.60		1.70		1.80		1.90		2.00		
	RPM	BHP	RPM	BHP	RPM	BHP	RPM	BHP	RPM	BHP	RPM	BHP	RPM	BHP	RPM	BHP	RPM	BHP	RPM	BHP	
<b>1-HP Standard Motor &amp; Drive</b>											<b>1-HP Standard Motor &amp; High Static Drive Kit (or 2-HP Oversized Motor &amp; Drive)</b>										
1920	941	0.99	977	1.07	1009	1.15	1041	1.23	1073	1.32	1103	1.40	1132	1.49	1159	1.57	1187	1.66	1213	1.75	
2160	964	1.13	997	1.23	1031	1.32	1061	1.41	1093	1.50	1123	1.60	1151	1.69	1179	1.78	1207	1.87	1234	1.97	
2400	988	1.29	1020	1.39	1054	1.50	1085	1.60	1114	1.70	1143	1.80	1171	1.90	1200	2.01	1227	2.11	1254	2.21	
2640	1014	1.47	1046	1.58	1077	1.69	1107	1.80	1138	1.91	1166	2.02	1193	2.13	1222	2.25	—	—	—	—	
2880	1042	1.68	1073	1.79	1103	1.90	1132	2.02	1162	2.14	1190	2.26	—	—	—	—	—	—	—	—	
											<b>2-HP Oversized Motor &amp; Drive</b>										

For Standard Evaporator Fan Speed (RPM), reference [Table 123](#).

Notes: Data includes pressure drop due to standard filters and wet coils. No accessories or options are included in pressure drop data.

Refer to [Table 128](#) to determine additional static pressure drop due to other options/accessories.

1-HP Fan Motor Heat (MBH) = 2.829 x Fan BHP+.4024. 2-HP Fan Motor Heat (MBH) = 3.000 x Fan BHP+.5000

Factory supplied motors, in commercial equipment, are definite purpose motors, specifically designed and tested to operate reliably and continuously at all cataloged conditions. Using the full horsepower range of our fan motors as shown in our tabular data will not result in nuisance tripping or premature motor failure. Our product's warranty will not be affected.

<sup>(i)</sup> Field Supplied Fan Sheave AK84 and Belt AX34 required.

**Table 100. Belt Drive Evaporator Fan Performance 6 Tons with Gas Heat YHC072A3,4,W\*H High Heat Downflow Airflow**

External Static Pressure (Inches of Water)																					
CFM	.10		.20		.30		.40		.50		.60		.70		.80		.90		1.00		
	RPM	BHP	RPM	BHP	RPM	BHP	RPM	BHP	RPM	BHP	RPM	BHP	RPM	BHP	RPM	BHP	RPM	BHP	RPM	BHP	
<b>1-HP Standard Motor &amp; Field Supplied Low Static Drive<sup>(i)</sup></b>											<b>1-HP Standard Motor &amp; Drive</b>										
1920	—	—	574	0.34	631	0.41	681	0.48	727	0.55	771	0.63	814	0.71	853	0.79	892	0.87	928	0.95	
2160	562	0.36	616	0.44	671	0.52	719	0.60	763	0.68	805	0.76	845	0.84	884	0.93	921	1.02	957	1.11	
2400	612	0.48	662	0.56	711	0.65	759	0.74	802	0.83	842	0.91	879	1.00	916	1.09	951	1.19	986	1.29	
2640	663	0.63	709	0.71	754	0.80	798	0.90	842	1.00	881	1.10	917	1.19	951	1.29	986	1.39	1018	1.49 <sup>(ii)</sup>	
2880	715	0.80	758	0.88	799	0.98	840	1.08	880	1.19	920	1.30	955	1.41	990	1.51	1022	1.62	1053	1.72	
											<b>2-HP Oversized Motor &amp; Drive</b>										

Continued

External Static Pressure (Inches of Water)																					
CFM	1.10		1.20		1.30		1.40		1.50		1.60		1.70		1.80		1.90		2.00		
	RPM	BHP	RPM	BHP	RPM	BHP	RPM	BHP	RPM	BHP	RPM	BHP	RPM	BHP	RPM	BHP	RPM	BHP	RPM	BHP	
<b>1-HP Standard Motor &amp; Drive</b>											<b>1-HP Standard Motor &amp; High Static Drive Kit (or 2-HP Oversized Motor &amp; Drive)</b>										
1920	963	1.04	997	1.12	1028	1.20	1061	1.28	1090	1.36	1119	1.45	1149	1.54	1177	1.63	1203	1.71	1229	1.80	
2160	990	1.21	1023	1.30	1055	1.39	1086	1.48	1115	1.57	1144	1.66	1173	1.76	1200	1.85	1227	1.95	1253	2.04	
2400	1019	1.39	1051	1.49	1083	1.60	1113	1.70	1141	1.80	1171	1.90	1199	2.01	1225	2.10	1252	2.20	—	—	
2640	1050	1.59	1081	1.70	1111	1.81	1141	1.93	1170	2.04	1198	2.15	1226	2.27	—	—	—	—	—	—	
2880	1084	1.83	1114	1.94	1143	2.06	1172	2.18	1199	2.30	—	—	—	—	—	—	—	—	—	—	
											<b>2-HP Oversized Motor &amp; Drive</b>										

For Standard Evaporator Fan Speed (RPM), reference [Table 123](#).

Notes: Data includes pressure drop due to standard filters and wet coils. No accessories or options are included in pressure drop data.

Refer to [Table 128](#) to determine additional static pressure drop due to other options/accessories.

1-HP Fan Motor Heat (MBH) = 2.829 x Fan BHP+.4024. 2-HP Fan Motor Heat (MBH) = 3.000 x Fan BHP+.5000

Factory supplied motors, in commercial equipment, are definite purpose motors, specifically designed and tested to operate reliably and continuously at all cataloged conditions. Using the full horsepower range of our fan motors as shown in our tabular data will not result in nuisance tripping or premature motor failure. Our product's warranty will not be affected.

<sup>(i)</sup> Field Supplied Fan Sheave AK84 and Belt AX34 required.

<sup>(ii)</sup> 1-HP Standard Motor & High Static Drive Kit (or 2-HP Oversized Motor).

## Performance Data

*(6 Tons High Efficiency)*

**Table 101. Belt Drive Evaporator Fan Performance 6 Tons with Gas Heat YHC072A3,4,W\*L,M Low & Medium Heat Horizontal Airflow**

External Static Pressure (Inches of Water)																					
		.10		.20		.30		.40		.50		.60		.70		.80		.90		1.00	
CFM	RPM	BHP	RPM	BHP	RPM	BHP	RPM	BHP	RPM	BHP	RPM	BHP	RPM	BHP	RPM	BHP	RPM	BHP	RPM	BHP	
<b>1-HP Standard Motor &amp; Field Supplied Low Static Drive<sup>(i)</sup></b>										<b>1-HP Standard Motor &amp; Drive</b>											
1920	—	—	591	0.34	649	0.42	699	0.48	745	0.56	789	0.64	834	0.72	877	0.81	918	0.89	957	0.97	
2160	587	0.38	633	0.44	690	0.52	740	0.61	784	0.68	825	0.76	865	0.85	904	0.95	943	1.04	981	1.13	
2400	643	0.51	682	0.58	732	0.65	781	0.75	825	0.84	864	0.92	902	1.01	938	1.11	974	1.21	1010	1.32 <sup>(ii)</sup>	
2640	700	0.66	736	0.74	775	0.81	822	0.90	866	1.01	906	1.11	942	1.20	976	1.29	1009	1.40	1042	1.51	
2880	756	0.84	790	0.93	823	1.01	864	1.09	907	1.20	947	1.32	983	1.43	1017	1.53	1048	1.62	1080	1.73	
										<b>2-HP Oversized Motor &amp; Drive</b>											

Continued

External Static Pressure (Inches of Water)																					
		1.10		1.20		1.30		1.40		1.50		1.60		1.70		1.80		1.90		2.00	
CFM	RPM	BHP	RPM	BHP	RPM	BHP	RPM	BHP	RPM	BHP	RPM	BHP	RPM	BHP	RPM	BHP	RPM	BHP	RPM	BHP	
<b>1-HP Standard Motor &amp; Drive</b>										<b>1-HP Standard Motor &amp; High Static Drive Kit (or 2-HP Oversized Motor &amp; Drive)</b>											
1920	996	1.06	1033	1.16	1067	1.25	1102	1.35	1134	1.44	1165	1.53	1195	1.63	1223	1.72	1251	1.82	1277	1.91	
2160	1018	1.23	1054	1.32	1090	1.42	1123	1.52	1156	1.63	1188	1.73	1218	1.84	1247	1.94	1276	2.05	1304	2.16	
2400	1044	1.42	1079	1.52	1112	1.62	1145	1.73	1177	1.83	1208	1.94	1240	2.06	1268	2.17	1298	2.29	—	—	
2640	1075	1.62	1107	1.74	1139	1.85	1170	1.96	1201	2.08	1232	2.19	—	—	—	—	—	—	—	—	
2880	1111	1.85	1140	1.97	1169	2.09	1200	2.22	—	—	—	—	—	—	—	—	—	—	—	—	
<b>2-HP Oversized Motor &amp; Drive</b>										<b>2-HP Oversized Motor &amp; Field Supplied High Static Drive<sup>(iii)</sup></b>											

For Standard Evaporator Fan Speed (RPM), reference [Table 123](#).

Notes: Data includes pressure drop due to standard filters and wet coils. No accessories or options are included in pressure drop data. Refer to [Table 128](#) to determine additional static pressure drop due to other options/accessories. 1-HP Fan Motor Heat (MBH) = 2.829 x Fan BHP + .4024. 2-HP Fan Motor Heat (MBH) = 3.000 x Fan BHP + .5000. Factory supplied motors, in commercial equipment, are definite purpose motors, specifically designed and tested to operate reliably and continuously at all cataloged conditions. Using the full horsepower range of our fan motors as shown in our tabular data will not result in nuisance tripping or premature motor failure. Our product's warranty will not be affected.

(i) Field Supplied Fan Sheave AK84 and Belt AX34 required.

(ii) 1-HP Standard Motor & High Static Drive (or 2-HP Oversized Motor).

(iii) Field Supplied Fan Sheave AK54 and Belt AX30 required.

**Table 102. Belt Drive Evaporator Fan Performance 6 Tons with Gas Heat YHC072A3,4,W\*H High Heat Horizontal Airflow**

External Static Pressure (Inches of Water)																					
		.10		.20		.30		.40		.50		.60		.70		.80		.90		1.00	
CFM	RPM	BHP	RPM	BHP	RPM	BHP	RPM	BHP	RPM	BHP	RPM	BHP	RPM	BHP	RPM	BHP	RPM	BHP	RPM	BHP	
<b>1-HP Standard Motor &amp; Field Supplied Low Static Drive<sup>(i)</sup></b>										<b>1-HP Standard Motor &amp; Drive</b>											
1920	565	0.31	627	0.39	680	0.46	727	0.52	772	0.61	816	0.69	859	0.77	902	0.86	942	0.94	981	1.03	
2160	621	0.43	677	0.50	729	0.59	774	0.66	816	0.74	856	0.83	895	0.93	934	1.02	973	1.11	1009	1.21 <sup>(ii)</sup>	
2400	680	0.57	729	0.65	778	0.74	823	0.84	862	0.92	900	1.00	936	1.10	972	1.20	1006	1.31	1041	1.41	
2640	741	0.75	782	0.82	828	0.92	872	1.03	911	1.13	947	1.21	981	1.31	1014	1.41	1048	1.53	1079	1.64	
2880	802	0.95	837	1.04	880	1.13	921	1.24	960	1.36	995	1.47	1028	1.56	1060	1.66	1091	1.77	1122	1.89	
										<b>2-HP Oversized Motor &amp; Drive</b>											

Continued

External Static Pressure (Inches of Water)																					
		1.10		1.20		1.30		1.40		1.50		1.60		1.70		1.80		1.90		2.00	
CFM	RPM	BHP	RPM	BHP	RPM	BHP	RPM	BHP	RPM	BHP	RPM	BHP	RPM	BHP	RPM	BHP	RPM	BHP	RPM	BHP	
<b>1-HP Standard Motor &amp; High Static Drive Kit (or 2-HP Oversized Motor &amp; Drive)</b>										<b>2-HP Oversized Motor &amp; Field Supplied High Static Drive<sup>(iii)</sup></b>											
1920	1018	1.12	1054	1.21	1089	1.31	1122	1.40	1154	1.50	1184	1.59	1212	1.69	1241	1.78	1268	1.88	1293	1.97	
2160	1045	1.30	1081	1.40	1114	1.50	1149	1.61	1181	1.71	1211	1.81	1241	1.92	1270	2.03	1298	2.13	1324	2.24	
2400	1076	1.51	1110	1.62	1143	1.72	1176	1.83	1206	1.94	1238	2.05	1267	2.16	1297	2.28	—	—	—	—	
2640	1111	1.75	1144	1.87	1174	1.98	1205	2.09	1236	2.21	—	—	—	—	—	—	—	—	—	—	
2880	1151	2.02	1180	2.14	1209	2.27	—	—	—	—	—	—	—	—	—	—	—	—	—	—	

For Standard Evaporator Fan Speed (RPM), reference [Table 123](#).

Notes: Data includes pressure drop due to standard filters and wet coils. No accessories or options are included in pressure drop data. Refer to [Table 128](#) to determine additional static pressure drop due to other options/accessories. 1-HP Fan Motor Heat (MBH) = 2.829 x Fan BHP + .4024. 2-HP Fan Motor Heat (MBH) = 3.000 x Fan BHP + .5000. Factory supplied motors, in commercial equipment, are definite purpose motors, specifically designed and tested to operate reliably and continuously at all cataloged conditions. Using the full horsepower range of our fan motors as shown in our tabular data will not result in nuisance tripping or premature motor failure. Our product's warranty will not be affected.

(i) Field Supplied Fan Sheave AK84 and Belt AX34 required.

(ii) 1-HP Standard Motor & High Static Drive Kit (or 2-HP Oversized Motor).

(iii) Field Supplied Fan Sheave AK54 and Belt AX30 required.

## Performance Data

*(7½ Tons High Efficiency)*

**Table 103. Belt Drive Evaporator Fan Performance 7½ Tons with Electric Heat THC092A3,4,W Downflow Airflow**

CFM	External Static Pressure (Inches of Water)																			
	.10		.20		.30		.40		.50		.60		.70		.80		.90		1.00	
	RPM	BHP	RPM	BHP	RPM	BHP	RPM	BHP	RPM	BHP	RPM	BHP	RPM	BHP	RPM	BHP	RPM	BHP	RPM	BHP
<b>2-HP Standard Motor &amp; Low Static Drive Accessory Kit<sup>(i)</sup></b>																				
1500*	—	—	—	—	—	—	510	0.30	557	0.39	602	0.48	643	0.57	682	0.66	718	0.76	753	0.87
1800*	—	—	—	—	481	0.27	534	0.36	579	0.45	621	0.55	661	0.65	699	0.75	735	0.86	770	0.97
2100*	—	—	—	—	506	0.33	557	0.42	604	0.52	645	0.62	683	0.73	719	0.85	754	0.97	787	1.08
2400	—	—	487	0.32	536	0.40	583	0.50	627	0.61	669	0.72	708	0.83	743	0.95	776	1.08	808	1.21
2700	—	—	522	0.41	569	0.50	611	0.60	653	0.71	693	0.83	731	0.95	768	1.07	801	1.20	832	1.33
3000	—	—	559	0.51	604	0.61	643	0.71	682	0.83	719	0.95	755	1.08	791	1.21	824	1.35	856	1.48
3300	—	—	599	0.63	639	0.74	678	0.86	713	0.97	748	1.09	783	1.23	815	1.37	848	1.52	880	1.66
3600	601	0.68	640	0.79	675	0.89	713	1.02	748	1.14	780	1.26	811	1.40	844	1.55	874	1.70	904	1.86
<b>2-HP Standard Motor &amp; Drive</b>																				

Continued

CFM	External Static Pressure (Inches of Water)																			
	1.10		1.20		1.30		1.40		1.50		1.60		1.70		1.80		1.90		2.00	
	RPM	BHP	RPM	BHP	RPM	BHP	RPM	BHP	RPM	BHP	RPM	BHP	RPM	BHP	RPM	BHP	RPM	BHP	RPM	BHP
<b>2-HP Standard Motor &amp; Low Static Drive Accessory Kit<sup>(ii)</sup></b>										<b>2-HP Standard Motor &amp; Drive</b>										
1500*	785	0.99	818	1.11	847	1.23	875	1.35	903	1.48	930	1.62	954	1.74	977	1.88	1001	2.01	1023	2.15
1800*	802	1.09	833	1.20	863	1.32	892	1.46	920	1.59	947	1.73	973	1.87	998	2.02	1023	2.17	1048	2.32
2100*	819	1.21	850	1.33	880	1.46	909	1.59	936	1.72	963	1.86	989	2.00	1014	2.15	1039	2.30	1064	2.46
2400	839	1.34	868	1.48	898	1.61	926	1.75	953	1.89	980	2.04	1006	2.18	1032	2.34	1056	2.49	1080	2.64
2700	862	1.48	891	1.62	918	1.77	946	1.92	971	2.07	998	2.23	1023	2.38	1049	2.54	1074	2.70	1097	2.86
3000	886	1.63	915	1.78	942	1.93	968	2.09	994	2.25	1019	2.42	1044	2.59	1067	2.75	1092	2.93	1115	3.09
3300	910	1.81	939	1.96	967	2.12	993	2.28	1019	2.45	1043	2.62	1066	2.79	1091	2.98	1113	3.15	1136	3.34
3600	933	2.01	962	2.17	990	2.33	1016	2.49	1042	2.66	1067	2.84	1091	3.02	1114	3.21	1137	3.39	1158	3.58
<b>3-HP Oversized Motor &amp; Drive</b>																				

For Standard Evaporator Fan Speed (RPM), reference [Table 123](#).

Table includes Dehumidification (Hot Gas Reheat Option).

Notes:

Data includes pressure drop due to standard filters and wet coils. Data does not include pressure drop due to reheat coil.

No accessories or options are included in pressure drop data.

Refer to [Table 128](#) to determine additional static pressure drop due to other options/accessories.

2-HP Fan Motor Heat (MBH) = 2.000 x Fan BHP + .5000. 3-HP Fan Motor Heat (MBH) = 2.900 x Fan BHP + .4750

Factory supplied motors, in commercial equipment, are definite purpose motors, specifically designed and tested to operate reliably and continuously at all cataloged conditions. Using the full horsepower range of our fan motors as shown in our tabular data will not result in nuisance tripping or premature motor failure. Our product's warranty will not be affected.

\*For 1500, 1800 and 2100 CFM, unit applications below 320 CFM/Ton are only applicable to T\_C models only (No Gas Heat). See below for restrictions.

- Electric heaters restricted on applications below 320 CFM/Ton.
- Dehumidification (Hot Gas Reheat) or TXV with Froststat and Crankcase Heaters are required on applications below 320 CFM/Ton.

<sup>(i)</sup> BAYLSDR009A required.

<sup>(ii)</sup> BAYLSDR009A required.

## Performance Data

*(7½ Tons High Efficiency)*

**Table 104. Belt Drive Evaporator Fan Performance 7½ Tons with Electric Heat THC092A3,4,W Horizontal Airflow**

CFM	External Static Pressure (Inches of Water)																			
	.10		.20		.30		.40		.50		.60		.70		.80		.90		1.00	
	RPM	BHP	RPM	BHP	RPM	BHP	RPM	BHP	RPM	BHP	RPM	BHP	RPM	BHP	RPM	BHP	RPM	BHP	RPM	BHP
<b>2-HP Standard Motor &amp; Low Static Drive Accessory Kit<sup>(1)</sup></b>																				
1500*	—	—	—	—	509	0.26	558	0.32	601	0.39	640	0.45	678	0.52	715	0.59	750	0.67	783	0.75
1800*	—	—	472	0.24	542	0.34	597	0.42	640	0.50	678	0.58	714	0.65	748	0.73	780	0.81	811	0.89
2100*	—	—	511	0.33	568	0.42	628	0.52	678	0.63	718	0.72	754	0.81	787	0.90	817	0.99	846	1.08
2400	502	0.36	552	0.43	603	0.52	653	0.63	707	0.75	754	0.88	792	0.99	825	1.09	857	1.19	886	1.30
2700	554	0.49	595	0.56	644	0.66	686	0.77	732	0.89	780	1.03	824	1.17	863	1.30	895	1.42	925	1.54
3000	605	0.65	644	0.73	684	0.82	726	0.94	765	1.06	806	1.20	849	1.35	891	1.51	929	1.66	962	1.80
3300	658	0.84	694	0.93	728	1.02	767	1.15	805	1.28	840	1.40	876	1.55	916	1.71	955	1.89	991	2.06
3600	711	1.07	746	1.18	776	1.27	809	1.38	846	1.52	880	1.66	912	1.80	943	1.95	980	2.13	1016	2.30
<b>2-HP Standard Motor &amp; Drive</b>																				

Continued

CFM	External Static Pressure (Inches of Water)																			
	1.10		1.20		1.30		1.40		1.50		1.60		1.70		1.80		1.90		2.00	
	RPM	BHP	RPM	BHP	RPM	BHP	RPM	BHP	RPM	BHP	RPM	BHP	RPM	BHP	RPM	BHP	RPM	BHP	RPM	BHP
<b>2-HP Standard Motor &amp; Drive</b>																				
1500*	815	0.83	847	0.91	876	0.99	904	1.07	932	1.16	958	1.25	985	1.34	1009	1.43	1033	1.51	1057	1.61
1800*	842	0.98	872	1.07	901	1.16	929	1.25	957	1.35	983	1.44	1008	1.54	1034	1.64	1058	1.74	1081	1.84
2100*	876	1.18	904	1.27	931	1.36	956	1.46	982	1.55	1008	1.66	1034	1.77	1059	1.87	1083	1.99	1107	2.10
2400	913	1.40	941	1.51	966	1.61	991	1.71	1017	1.82	1040	1.92	1064	2.04	1087	2.14	1110	2.26	1132	2.37
2700	954	1.66	981	1.77	1006	1.89	1030	2.00	1054	2.12	1077	2.24	1100	2.36	1121	2.47	1144	2.60	1164	2.71
3000	992	1.94	1019	2.07	1045	2.20	1069	2.32	1094	2.46	1116	2.58	1138	2.71	1160	2.84	1181	2.97	1202	3.10
3300	1025	2.22	1055	2.38	1082	2.53	1108	2.67	1132	2.82	1156	2.96	1178	3.11	1200	3.25	1221	3.39	—	—
3600	1052	2.50	1085	2.69	1117	2.88	1144	3.05	1170	3.21	1193	3.37	—	—	—	—	—	—	—	—
<b>3-HP Oversized Motor &amp; Drive</b>																				

For Standard Evaporator Fan Speed (RPM), reference [Table 123](#).

Table includes Dehumidification (Hot Gas Reheat Option).

Notes:

Data includes pressure drop due to standard filters and wet coils. Data does not include pressure drop due to reheat coil.

No accessories or options are included in pressure drop data.

Refer to [Table 128](#) to determine additional static pressure drop due to other options/accessories.

1 HP Fan Motor Heat (MBH) = 2.829 x Fan BHP+.4024. 2-HP Fan Motor Heat (MBH) = 2.000 x Fan BHP+.5000. 3-HP Fan Motor Heat (MBH) = 2.900 x Fan BHP+.4750

Factory supplied motors, in commercial equipment, are definite purpose motors, specifically designed and tested to operate reliably and continuously at all cataloged conditions. Using the full horsepower range of our fan motors as shown in our tabular data will not result in nuisance tripping or premature motor failure. Our product's warranty will not be affected.

\*For 1500, 1800 and 2100 CFM, unit applications below 320 CFM/Ton are only applicable to T\_C models only (No Gas Heat). See below for restrictions.

- Electric heaters restricted on applications below 320 CFM/Ton.
- Dehumidification (Hot Gas Reheat) or TXV with Froststat and Crankcase Heaters are required on applications below 320 CFM/Ton.

<sup>(1)</sup> BAYLSDR009A required.

## Performance Data

*(7½ Tons High Efficiency)*

**Table 105. Belt Drive Evaporator Fan Performance 7½ Tons with Gas Heat YHC092A3,4,W\*L,M Low & Medium Heat Downflow Airflow**

CFM	External Static Pressure (Inches of Water)																				
	.10		.20		.30		.40		.50		.60		.70		.80		.90		1.00		
RPM	BHP	RPM	BHP	RPM	BHP	RPM	BHP	RPM	BHP	RPM	BHP	RPM	BHP	RPM	BHP	RPM	BHP	RPM	BHP	RPM	BHP
<b>2-HP Standard Motor &amp; Field Supplied Low Static Drive<sup>(1)</sup></b>																					
2400	—	—	—	—	—	—	—	613	0.58	656	0.68	696	0.79	732	0.91	765	1.03	798	1.16	829	1.30
2700	—	—	—	—	605	0.58	647	0.69	687	0.81	726	0.93	762	1.05	796	1.18	828	1.32	857	1.45	
3000	—	—	606	0.62	645	0.72	684	0.83	721	0.96	758	1.09	792	1.22	826	1.36	858	1.49	888	1.64	
3300	609	0.66	650	0.77	688	0.89	723	1.00	758	1.13	792	1.27	825	1.41	857	1.56	888	1.70	918	1.85	
3600	658	0.84	695	0.96	731	1.08	764	1.20	796	1.33	828	1.47	859	1.63	890	1.79	920	1.94	949	2.10	
<b>2-HP Oversized Motor &amp; Drive</b>																					

Continued

CFM	External Static Pressure (Inches of Water)																				
	1.10		1.20		1.30		1.40		1.50		1.60		1.70		1.80		1.90		2.00		
RPM	BHP	RPM	BHP	RPM	BHP	RPM	BHP	RPM	BHP	RPM	BHP	RPM	BHP	RPM	BHP	RPM	BHP	RPM	BHP	RPM	BHP
<b>2-HP Standard Motor &amp; Drive</b>																					
2400	858	1.43	888	1.57	917	1.71	945	1.85	971	1.99	998	2.14	1023	2.28	1048	2.44	1072	2.59	1095	2.75	
2700	886	1.60	915	1.75	942	1.90	969	2.05	995	2.21	1020	2.36	1045	2.51	1069	2.67	1093	2.83	1117	3.00	
3000	916	1.79	944	1.94	970	2.10	995	2.26	1020	2.43	1044	2.59	1069	2.76	1092	2.93	1116	3.10	1139	3.27	
3300	947	2.01	974	2.16	1000	2.33	1026	2.50	1050	2.67	1073	2.84	1097	3.02	1119	3.20	1141	3.38	—	—	
3600	976	2.25	1004	2.42	1030	2.58	1056	2.76	1080	2.94	1103	3.12	1126	3.30	—	—	—	—	—	—	
<b>3-HP Oversized Motor &amp; Drive</b>																					

For Standard Evaporator Fan Speed (RPM), reference [Table 123](#).

Notes: Data includes pressure drop due to standard filters and wet coils. No accessories or options are included in pressure drop data.

Refer to [Table 128](#) to determine additional static pressure drop due to other options/accessories.

2-HP Fan Motor Heat (MBH) = 2.000 x Fan BHP+.5000. 3-HP Fan Motor Heat (MBH) = 2.900 x Fan BHP+.4750.

Factory supplied motors, in commercial equipment, are definite purpose motors, specifically designed and tested to operate reliably and continuously at all cataloged conditions. Using the full horsepower range of our fan motors as shown in our tabular data will not result in nuisance tripping or premature motor failure. Our product's warranty will not be affected.

<sup>(1)</sup> Field Supplied Fan Sheave AK79 and Belt AX38 required.

**Table 106. Belt Drive Evaporator Fan Performance 7½ Tons with Gas Heat YHC092A3,4,W\*H High Heat Downflow Airflow**

CFM	External Static Pressure (Inches of Water)																				
	.10		.20		.30		.40		.50		.60		.70		.80		.90		1.00		
RPM	BHP	RPM	BHP	RPM	BHP	RPM	BHP	RPM	BHP	RPM	BHP	RPM	BHP	RPM	BHP	RPM	BHP	RPM	BHP	RPM	BHP
<b>2-HP Standard Motor &amp; Field Supplied Low Static Drive<sup>(1)</sup></b>																					
2400	—	—	—	—	—	—	—	623	0.60	664	0.70	703	0.82	739	0.93	773	1.06	804	1.19	835	1.32
2700	—	—	—	—	617	0.61	658	0.73	698	0.84	736	0.96	771	1.08	804	1.21	835	1.35	865	1.49	
3000	—	—	619	0.65	658	0.75	696	0.87	733	1.00	770	1.13	804	1.26	837	1.40	868	1.54	897	1.69	
3300	625	0.70	666	0.82	702	0.93	737	1.05	771	1.19	805	1.33	838	1.47	870	1.62	900	1.76	929	1.91	
3600	675	0.89	713	1.02	747	1.14	779	1.26	811	1.40	843	1.55	874	1.70	904	1.86	934	2.02	962	2.17	
<b>2-HP Standard Motor &amp; Drive</b>																					

Continued

CFM	External Static Pressure (Inches of Water)																				
	1.10		1.20		1.30		1.40		1.50		1.60		1.70		1.80		1.90		2.00		
RPM	BHP	RPM	BHP	RPM	BHP	RPM	BHP	RPM	BHP	RPM	BHP	RPM	BHP	RPM	BHP	RPM	BHP	RPM	BHP	RPM	BHP
<b>2-HP Standard Motor &amp; Drive</b>																					
2400	864	1.46	895	1.60	923	1.74	951	1.88	977	2.02	1003	2.17	1028	2.32	1053	2.47	1078	2.63	1100	2.78	
2700	894	1.64	921	1.79	948	1.94	974	2.09	1001	2.24	1027	2.40	1052	2.56	1076	2.72	1100	2.88	1124	3.05	
3000	925	1.83	952	1.99	978	2.15	1004	2.32	1029	2.48	1052	2.65	1076	2.82	1100	2.99	1123	3.15	1146	3.33	
3300	958	2.06	984	2.22	1010	2.39	1035	2.56	1059	2.73	1082	2.91	1105	3.09	1128	3.28	—	—	—	—	
3600	990	2.33	1017	2.50	1043	2.66	1067	2.84	1091	3.02	1114	3.20	1137	3.39	—	—	—	—	—	—	
<b>3-HP Oversized Motor &amp; Drive</b>																					

For Standard Evaporator Fan Speed (RPM), reference [Table 123](#).

Notes: Data includes pressure drop due to standard filters and wet coils. No accessories or options are included in pressure drop data.

Refer to [Table 128](#) to determine additional static pressure drop due to other options/accessories.

2-HP Fan Motor Heat (MBH) = 2.000 x Fan BHP+.5000. 3-HP Fan Motor Heat (MBH) = 2.900 x Fan BHP+.4750.

Factory supplied motors, in commercial equipment, are definite purpose motors, specifically designed and tested to operate reliably and continuously at all cataloged conditions. Using the full horsepower range of our fan motors as shown in our tabular data will not result in nuisance tripping or premature motor failure. Our product's warranty will not be affected.

<sup>(1)</sup> Field Supplied Fan Sheave AK79 and Belt AX38 required.

## Performance Data

*(7½ Tons High Efficiency)*

**Table 107. Belt Drive Evaporator Fan Performance 7½ Tons with Gas Heat YHC092A3,4,W\*L,M Low & Medium Heat Horizontal Airflow**

External Static Pressure (Inches of Water)																					
		.10		.20		.30		.40		.50		.60		.70		.80		.90		1.00	
CFM	RPM	BHP	RPM	BHP	RPM	BHP	RPM	BHP	RPM	BHP	RPM	BHP	RPM	BHP	RPM	BHP	RPM	BHP	RPM	BHP	
<b>2-HP Standard Motor &amp; Field Supplied Low Static Drive<sup>(1)</sup></b>																					
2400	—	—	599	0.52	650	0.62	703	0.75	751	0.87	789	0.98	823	1.08	855	1.19	885	1.29	912	1.39	
2700	604	0.58	651	0.68	694	0.79	741	0.91	789	1.06	832	1.19	868	1.32	900	1.44	931	1.56	959	1.68	
3000	661	0.77	705	0.88	744	1.00	783	1.12	826	1.26	869	1.42	909	1.58	945	1.73	976	1.86	1004	1.99	
3300	719	1.00	758	1.11	797	1.25	832	1.37	867	1.51	907	1.68	946	1.85	983	2.02	1017	2.18	1048	2.34	
3600	779	1.28	813	1.39	850	1.54	883	1.68	915	1.82	948	1.97	984	2.15	1020	2.33	1055	2.52	1088	2.71	
<b>2-HP Standard Motor &amp; Drive</b>														<b>3-HP Oversized Motor &amp; Drive</b>							

Continued

External Static Pressure (Inches of Water)																					
		1.10		1.20		1.30		1.40		1.50		1.60		1.70		1.80		1.90		2.00	
CFM	RPM	BHP	RPM	BHP	RPM	BHP	RPM	BHP	RPM	BHP	RPM	BHP	RPM	BHP	RPM	BHP	RPM	BHP	RPM	BHP	
<b>2-HP Standard Motor &amp; Drive</b>																					
2400	939	1.50	965	1.60	990	1.71	1014	1.81	1039	1.92	1063	2.03	1085	2.14	1108	2.25	1131	2.36	1154	2.49	
2700	985	1.79	1010	1.91	1034	2.03	1058	2.14	1081	2.26	1104	2.38	1126	2.50	1148	2.62	1169	2.74	1190	2.86	
3000	1031	2.12	1056	2.25	1081	2.39	1104	2.51	1127	2.65	1148	2.77	1169	2.90	1190	3.03	1210	3.16	1231	3.30	
3300	1077	2.50	1102	2.64	1127	2.78	1151	2.93	1174	3.07	1194	3.21	1216	3.36	—	—	—	—	—	—	
3600	1120	2.89	1146	3.06	1172	3.22	1195	3.38	—	—	—	—	—	—	—	—	—	—	—	—	
<b>2-HP Standard Motor &amp; Drive</b>														<b>3-HP Oversized Motor &amp; Drive</b>							

For Standard Evaporator Fan Speed (RPM), reference [Table 123](#).

Notes: Data includes pressure drop due to standard filters and wet coils. No accessories or options are included in pressure drop data.

Refer to [Table 128](#) to determine additional static pressure drop due to other options/accessories.

2-HP Fan Motor Heat (MBH) = 2.000 x Fan BHP+.5000. 3-HP Fan Motor Heat (MBH) = 2.900 x Fan BHP+.4750

Factory supplied motors, in commercial equipment, are definite purpose motors, specifically designed and tested to operate reliably and continuously at all cataloged conditions. Using the full horsepower range of our fan motors as shown in our tabular data will not result in nuisance tripping or premature motor failure. Our product's warranty will not be affected.

<sup>(1)</sup> Field Supplied Fan Sheave AK79 and Belt AX38 required.

**Table 108. Belt Drive Evaporator Fan Performance 7½ Tons with Gas Heat YHC092A3,4,W\*H High Heat Horizontal Airflow**

External Static Pressure (Inches of Water)																					
		.10		.20		.30		.40		.50		.60		.70		.80		.90		1.00	
CFM	RPM	BHP	RPM	BHP	RPM	BHP	RPM	BHP	RPM	BHP	RPM	BHP	RPM	BHP	RPM	BHP	RPM	BHP	RPM	BHP	
<b>2-HP Standard Motor &amp; Field Supplied Low Static Drive<sup>(1)</sup></b>																					
2400	—	—	613	0.54	666	0.66	718	0.78	762	0.90	799	1.01	833	1.11	864	1.22	893	1.32	920	1.42	
2700	621	0.61	667	0.72	710	0.83	759	0.97	804	1.10	846	1.24	880	1.36	911	1.48	941	1.60	968	1.72	
3000	680	0.81	723	0.93	761	1.05	802	1.18	845	1.33	888	1.49	925	1.64	959	1.79	988	1.92	1016	2.05	
3300	740	1.06	780	1.19	816	1.31	850	1.45	889	1.60	928	1.77	966	1.94	1002	2.11	1036	2.28	1063	2.42	
3600	800	1.35	837	1.49	872	1.63	904	1.77	935	1.91	971	2.08	1007	2.27	1043	2.45	1077	2.64	1108	2.83	
<b>2-HP Standard Motor &amp; Drive</b>														<b>3-HP Oversized Motor &amp; Drive</b>							

Continued

External Static Pressure (Inches of Water)																					
		1.10		1.20		1.30		1.40		1.50		1.60		1.70		1.80		1.90		2.00	
CFM	RPM	BHP	RPM	BHP	RPM	BHP	RPM	BHP	RPM	BHP	RPM	BHP	RPM	BHP	RPM	BHP	RPM	BHP	RPM	BHP	
<b>2-HP Standard Motor &amp; Drive</b>																					
2400	946	1.53	972	1.64	997	1.74	1022	1.84	1045	1.95	1069	2.06	1092	2.17	1115	2.28	1137	2.40	1160	2.52	
2700	994	1.84	1019	1.95	1043	2.07	1066	2.18	1089	2.30	1112	2.42	1134	2.54	1155	2.66	1177	2.78	1197	2.90	
3000	1043	2.18	1067	2.31	1091	2.44	1114	2.57	1137	2.70	1158	2.83	1178	2.96	1200	3.09	1220	3.22	1240	3.35	
3300	1090	2.57	1116	2.72	1140	2.86	1162	3.00	1185	3.15	1206	3.29	1227	3.43	—	—	—	—	—	—	
3600	137	3.00	1163	3.17	1188	3.33	—	—	—	—	—	—	—	—	—	—	—	—	—	—	
<b>2-HP Standard Motor &amp; Drive</b>														<b>3-HP Oversized Motor &amp; Drive</b>							

For Standard Evaporator Fan Speed (RPM), reference [Table 123](#).

Notes: Data includes pressure drop due to standard filters and wet coils. No accessories or options are included in pressure drop data.

Refer to [Table 128](#) to determine additional static pressure drop due to other options/accessories.

2-HP Fan Motor Heat (MBH) = 2.000 x Fan BHP+.5000. 3-HP Fan Motor Heat (MBH) = 2.900 x Fan BHP+.4750

Factory supplied motors, in commercial equipment, are definite purpose motors, specifically designed and tested to operate reliably and continuously at all cataloged conditions. Using the full horsepower range of our fan motors as shown in our tabular data will not result in nuisance tripping or premature motor failure. Our product's warranty will not be affected.

<sup>(1)</sup> Field Supplied Fan Sheave AK79 and Belt AX38 required.

## Performance Data

*(8½ Tons High Efficiency)*

**Table 109. Belt Drive Evaporator Fan Performance 8½ Tons with Electric Heat THC102A3,4,W Downflow Airflow**

External Static Pressure (Inches of Water)																				
CFM	.10		.20		.30		.40		.50		.60		.70		.80		.90		1.00	
	RPM	BHP	RPM	BHP	RPM	BHP	RPM	BHP	RPM	BHP	RPM	BHP	RPM	BHP	RPM	BHP	RPM	BHP	RPM	BHP
<b>2-HP Standard Motor &amp; Field Supplied Low Static Drive Accessory Kit<sup>(1)</sup></b>																				
1700*	—	—	—	—	481	0.26	533	0.35	578	0.44	621	0.54	661	0.64	700	0.74	736	0.85	770	0.96
2040*	—	—	—	—	511	0.34	562	0.43	608	0.52	649	0.63	686	0.74	722	0.85	757	0.97	791	1.09
2380*	—	—	496	0.33	545	0.42	592	0.52	637	0.63	678	0.74	716	0.86	751	0.98	784	1.11	815	1.24
2720	—	—	539	0.44	584	0.53	626	0.64	668	0.76	708	0.88	746	1.00	781	1.12	814	1.26	845	1.40
3060	—	—	583	0.58	626	0.68	665	0.78	703	0.90	740	1.04	775	1.17	810	1.30	843	1.44	875	1.58
3400	—	—	628	0.72	669	0.84	706	0.96	741	1.08	775	1.21	809	1.36	841	1.51	873	1.65	904	1.81
3740	641	0.81	677	0.92	713	1.04	749	1.17	781	1.30	813	1.43	845	1.58	875	1.73	905	1.89	935	2.06
4080	693	1.03	726	1.15	758	1.27	792	1.41	824	1.56	854	1.69	883	1.83	912	1.99	940	2.16	968	2.33
<b>2-HP Standard Motor &amp; Drive</b>																				

Continued

External Static Pressure (Inches of Water)																				
CFM	1.10		1.20		1.30		1.40		1.50		1.60		1.70		1.80		1.90		2.00	
	RPM	BHP	RPM	BHP	RPM	BHP	RPM	BHP	RPM	BHP	RPM	BHP	RPM	BHP	RPM	BHP	RPM	BHP	RPM	BHP
<b>2-HP Standard Motor &amp; Drive</b>																				
1700*	802	1.07	833	1.19	864	1.32	893	1.45	921	1.59	948	1.72	972	1.86	998	2.01	1022	2.15	1045	2.30
2040*	823	1.21	854	1.34	884	1.47	913	1.60	940	1.73	967	1.87	993	2.01	1018	2.16	1043	2.32	1068	2.48
2380*	846	1.37	876	1.51	906	1.65	934	1.79	962	1.93	988	2.08	1014	2.22	1038	2.37	1064	2.53	1087	2.69
2720	874	1.54	904	1.69	930	1.84	958	2.00	983	2.14	1010	2.30	1035	2.46	1060	2.62	1084	2.78	1109	2.95
3060	905	1.73	933	1.89	960	2.05	986	2.20	1010	2.37	1035	2.54	1059	2.71	1083	2.89	1107	3.06	1131	3.24
3400	933	1.96	962	2.11	990	2.27	1016	2.44	1041	2.62	1065	2.79	1089	2.97	1112	3.15	1134	3.34	—	—
3740	964	2.22	992	2.39	1018	2.55	1045	2.72	1071	2.90	1095	3.08	1118	3.26	1141	3.45	—	—	—	—
4080	995	2.51	1023	2.69	1048	2.86	1075	3.05	1100	3.23	1124	3.41	—	—	—	—	—	—	—	—
<b>3-HP Oversized Motor &amp; Drive</b>																				

For Standard Evaporator Fan Speed (RPM), reference [Table 123](#).

Table includes Dehumidification (Hot Gas Reheat Option).

Notes:

Data includes pressure drop due to standard filters and wet coils. Data does not include pressure drop due to reheat coil.

No accessories or options are included in pressure drop data.

Refer to [Table 128](#) to determine additional static pressure drop due to other options/accessories.

1 HP Fan Motor Heat (MBH) = 2.829 x Fan BHP + .4024. 2-HP Fan Motor Heat (MBH) = 2.000 x Fan BHP + .5000. 3-HP Fan Motor Heat (MBH) = 2.900 x Fan BHP + .4750

Factory supplied motors, in commercial equipment, are definite purpose motors, specifically designed and tested to operate reliably and continuously at all cataloged conditions. Using the full horsepower range of our fan motors as shown in our tabular data will not result in nuisance tripping or premature motor failure. Our product's warranty will not be affected.

\*For 1700, 2040 and 2380 CFM, unit applications below 320 CFM/Ton are only applicable to T\_C models only (No Gas Heat). See below for restrictions.

- Electric heaters restricted on applications below 320 CFM/Ton.
- Dehumidification (Hot Gas Reheat) or TXV with Froststat and Crankcase Heaters are required on applications below 320 CFM/Ton.

<sup>(1)</sup> BAYLSDR009A Required.



## Performance Data

*(8½ Tons High Efficiency)*

**Table 110. Belt Drive Evaporator Fan Performance 8½ Tons with Electric Heat THC102A3,4,W Horizontal Airflow**

CFM	External Static Pressure (Inches of Water)																			
	.10		.20		.30		.40		.50		.60		.70		.80		.90		1.00	
	RPM	BHP	RPM	BHP	RPM	BHP	RPM	BHP	RPM	BHP	RPM	BHP	RPM	BHP	RPM	BHP	RPM	BHP	RPM	BHP
<b>2-HP Standard Motor &amp; Field Supplied Low Static Drive Accessory Kit<sup>(1)</sup></b>																				
1700*	—	—	473	0.24	542	0.32	591	0.40	633	0.47	672	0.55	707	0.62	742	0.70	774	0.77	807	0.86
2040*	—	—	513	0.32	575	0.42	634	0.53	679	0.62	719	0.71	754	0.80	787	0.89	817	0.97	846	1.06
2380*	509	0.36	562	0.45	612	0.54	666	0.66	719	0.78	763	0.90	800	1.01	832	1.11	863	1.21	893	1.32
2720	570	0.52	612	0.60	660	0.71	703	0.81	751	0.95	798	1.09	841	1.23	877	1.36	909	1.48	939	1.60
3060	631	0.72	667	0.80	709	0.91	750	1.03	788	1.15	830	1.29	873	1.45	914	1.62	951	1.77	983	1.92
3400	692	0.96	726	1.05	760	1.15	800	1.29	836	1.42	870	1.56	907	1.71	945	1.88	984	2.06	1020	2.24
3740	754	1.26	786	1.36	815	1.46	850	1.59	886	1.74	918	1.88	949	2.03	980	2.19	1015	2.37	1052	2.57
4080	817	1.61	848	1.72	874	1.83	903	1.95	935	2.10	968	2.26	998	2.42	1026	2.58	1054	2.75	1085	2.94
<b>2-HP Standard Motor &amp; Drive</b>											<b>3-HP Standard Motor &amp; Drive</b>									

Continued

CFM	External Static Pressure (Inches of Water)																			
	1.10		1.20		1.30		1.40		1.50		1.60		1.70		1.80		1.90		2.00	
	RPM	BHP	RPM	BHP	RPM	BHP	RPM	BHP	RPM	BHP	RPM	BHP	RPM	BHP	RPM	BHP	RPM	BHP	RPM	BHP
<b>2-HP Standard Motor &amp; Drive</b>																				
1700*	839	0.94	869	1.03	898	1.12	926	1.21	953	1.30	980	1.40	1005	1.49	1031	1.59	1054	1.68	1078	1.78
2040*	876	1.16	903	1.25	930	1.34	957	1.44	984	1.54	1010	1.64	1036	1.75	1061	1.86	1084	1.96	1108	2.07
2380*	920	1.42	946	1.52	973	1.63	998	1.73	1021	1.83	1047	1.95	1069	2.05	1093	2.16	1115	2.27	1138	2.39
2720	967	1.72	994	1.84	1018	1.96	1042	2.07	1066	2.19	1089	2.31	1112	2.43	1134	2.55	1155	2.67	1176	2.79
3080	1012	2.06	1039	2.19	1065	2.32	1090	2.46	1113	2.59	1136	2.73	1158	2.86	1179	2.99	1199	3.12	1220	3.26
3400	1052	2.41	1083	2.58	1109	2.73	1135	2.88	1159	3.04	1183	3.19	1204	3.33	—	—	—	—	—	—
3740	1086	2.77	1119	2.96	1149	3.15	1178	3.34	—	—	—	—	—	—	—	—	—	—	—	—
4080	1117	3.14	1151	3.36	—	—	—	—	—	—	—	—	—	—	—	—	—	—	—	—
<b>3-HP Oversized Motor &amp; Drive</b>																				

For Standard Evaporator Fan Speed (RPM), reference [Table 123](#).

Table includes Dehumidification (Hot Gas Reheat Option).

Notes:

Data includes pressure drop due to standard filters and wet coils. Data does not include pressure drop due to reheat coil.

No accessories or options are included in pressure drop data.

Refer to [Table 128](#) to determine additional static pressure drop due to other options/accessories.

1 HP Fan Motor Heat (MBH) = 2.829 x Fan BHP+.4024. 2-HP Fan Motor Heat (MBH) = 2.000 x Fan BHP+.5000. 3-HP Fan Motor Heat (MBH) = 2.900 x Fan BHP+.4750

Factory supplied motors, in commercial equipment, are definite purpose motors, specifically designed and tested to operate reliably and continuously at all cataloged conditions. Using the full horsepower range of our fan motors as shown in our tabular data will not result in nuisance tripping or premature motor failure. Our product's warranty will not be affected.

\*For 1700, 2040 and 2380 CFM, unit applications below 320 CFM/Ton are only applicable to T\_C models only (No Gas Heat). See below for restrictions.

- Electric heaters restricted on applications below 320 CFM/Ton.
- Dehumidification (Hot Gas Reheat) or TXV with Froststat and Crankcase Heaters are required on applications below 320 CFM/Ton.

<sup>(1)</sup> BAYLSDR009A required.

**Performance Data**

*(8½ Tons High Efficiency)*

**Table 111. Belt Drive Evaporator Fan Performance 8½ Tons with Gas Heat YHC102A3,4,W\*L Low Heat Downflow Airflow**

External Static Pressure (Inches of Water)																					
		.10		.20		.30		.40		.50		.60		.70		.80		.90		1.00	
CFM	RPM	BHP	RPM	BHP	RPM	BHP	RPM	BHP	RPM	BHP	RPM	BHP	RPM	BHP	RPM	BHP	RPM	BHP	RPM	BHP	
<b>2-HP Standard Motor &amp; Field Supplied Low Static Drive<sup>(1)</sup></b>																					
2720	—	—	—	—	621	0.62	662	0.74	703	0.86	741	0.98	777	1.11	810	1.24	841	1.38	871	1.52	
3060	587	0.58	630	0.69	668	0.79	707	0.92	743	1.05	779	1.18	814	1.32	846	1.45	878	1.60	907	1.75	
3400	643	0.77	683	0.89	718	1.00	753	1.13	787	1.26	820	1.41	853	1.56	884	1.71	915	1.86	944	2.02	
3740	699	0.99	736	1.12	770	1.25	802	1.38	833	1.52	864	1.67	894	1.83	925	2.00	953	2.16	982	2.33	
4080	757	1.26	790	1.40	823	1.55	853	1.69	882	1.83	910	1.98	938	2.15	967	2.32	994	2.50	1021	2.68	
<b>2-HP Standard Motor &amp; Drive</b>															<b>3-HP Oversized Motor &amp; Drive</b>						

Continued

External Static Pressure (Inches of Water)																					
		1.10		1.20		1.30		1.40		1.50		1.60		1.70		1.80		1.90		2.00	
CFM	RPM	BHP	RPM	BHP	RPM	BHP	RPM	BHP	RPM	BHP	RPM	BHP	RPM	BHP	RPM	BHP	RPM	BHP	RPM	BHP	
<b>2-HP Standard Motor &amp; Drive</b>																					
2720	900	1.67	927	1.82	954	1.97	980	2.12	1006	2.28	1032	2.44	1057	2.60	1082	2.76	1105	2.92	1129	3.09	
3060	936	1.90	962	2.06	989	2.22	1014	2.39	1039	2.56	1062	2.73	1085	2.90	1109	3.07	1133	3.25	1155	3.43	
3400	973	2.17	999	2.34	1025	2.51	1050	2.68	1074	2.86	1097	3.04	1120	3.22	1142	3.41	—	—	—	—	
3740	1010	2.50	1036	2.66	1062	2.84	1087	3.01	1110	3.19	1134	3.39	—	—	—	—	—	—	—	—	
4080	1047	2.86	1073	3.04	1098	3.22	1123	3.40	—	—	—	—	—	—	—	—	—	—	—	—	
<b>3-HP Oversized Motor &amp; Drive</b>																					

For Standard Evaporator Fan Speed (RPM), reference [Table 123](#).

Notes:

Data includes pressure drop due to standard filters and wet coils. No accessories or options are included in pressure drop data.

Refer to [Table 128](#) to determine additional static pressure drop due to other options/accessories.

2-HP Fan Motor Heat (MBH) = 2.000 x Fan BHP+.5000. 3-HP Fan Motor Heat (MBH) = 2.900 x Fan BHP+.4750

Factory supplied motors, in commercial equipment, are definite purpose motors, specifically designed and tested to operate reliably and continuously at all cataloged conditions. Using the full horsepower range of our fan motors as shown in our tabular data will not result in nuisance tripping or premature motor failure. Our product's warranty will not be affected.

<sup>(1)</sup> Field Supplied Fan Sheave AK79 and Belt AX38 required.

**Table 112. Belt Drive Evaporator Fan Performance 8½ Tons with Gas Heat YHC102A3,4,W\*M Medium Heat Downflow Airflow**

External Static Pressure (Inches of Water)																					
		.10		.20		.30		.40		.50		.60		.70		.80		.90		1.00	
CFM	RPM	BHP	RPM	BHP	RPM	BHP	RPM	BHP	RPM	BHP	RPM	BHP	RPM	BHP	RPM	BHP	RPM	BHP	RPM	BHP	
<b>2-HP Standard Motor &amp; Field Supplied Low Static Drive<sup>(1)</sup></b>																					
2720	—	—	—	—	623	0.63	664	0.75	704	0.87	742	0.99	778	1.11	811	1.24	842	1.38	872	1.53	
3060	589	0.58	632	0.69	670	0.80	709	0.92	745	1.06	781	1.19	815	1.32	848	1.46	880	1.60	909	1.75	
3400	645	0.77	685	0.89	721	1.01	755	1.13	789	1.27	822	1.42	854	1.57	886	1.72	916	1.87	945	2.02	
3740	702	1.00	739	1.14	772	1.26	804	1.39	836	1.53	867	1.69	897	1.85	926	2.01	956	2.18	984	2.34	
4080	759	1.27	793	1.42	826	1.56	856	1.70	884	1.84	913	2.00	941	2.16	969	2.34	996	2.52	1024	2.70	
<b>2-HP Standard Motor &amp; Drive</b>															<b>3-HP Oversized Motor &amp; Drive</b>						

Continued

External Static Pressure (Inches of Water)																					
		1.10		1.20		1.30		1.40		1.50		1.60		1.70		1.80		1.90		2.00	
CFM	RPM	BHP	RPM	BHP	RPM	BHP	RPM	BHP	RPM	BHP	RPM	BHP	RPM	BHP	RPM	BHP	RPM	BHP	RPM	BHP	
<b>2-HP Standard Motor &amp; Drive</b>																					
2720	900	1.67	928	1.82	955	1.98	982	2.14	1008	2.29	1033	2.45	1057	2.60	1083	2.77	1107	2.94	1129	3.10	
3060	936	1.91	964	2.07	989	2.23	1015	2.39	1039	2.56	1063	2.73	1088	2.92	1111	3.09	1134	3.26	1157	3.44	
3400	974	2.18	1001	2.35	1027	2.52	1051	2.69	1075	2.87	1098	3.05	1121	3.23	1144	3.42	—	—	—	—	
3740	1011	2.50	1038	2.68	1064	2.85	1089	3.03	1113	3.22	1135	3.40	—	—	—	—	—	—	—	—	
4080	1050	2.87	1076	3.05	1101	3.24	1126	3.43	—	—	—	—	—	—	—	—	—	—	—	—	
<b>3-HP Oversized Motor &amp; Drive</b>																					

For Standard Evaporator Fan Speed (RPM), reference [Table 123](#).

Notes:

Data includes pressure drop due to standard filters and wet coils. No accessories or options are included in pressure drop data.

Refer to [Table 128](#) to determine additional static pressure drop due to other options/accessories.

2-HP Fan Motor Heat (MBH) = 2.000 x Fan BHP+.5000. 3-HP Fan Motor Heat (MBH) = 2.900 x Fan BHP+.4750

Factory supplied motors, in commercial equipment, are definite purpose motors, specifically designed and tested to operate reliably and continuously at all cataloged conditions. Using the full horsepower range of our fan motors as shown in our tabular data will not result in nuisance tripping or premature motor failure. Our product's warranty will not be affected.

<sup>(1)</sup> Field Supplied Fan Sheave AK79 and Belt AX38 required.

## Performance Data

*(8½ Tons High Efficiency)*

**Table 113. Belt Drive Evaporator Fan Performance 8½ Tons with Gas Heat YHC102A3,4,W\*H High Heat Downflow Airflow**

External Static Pressure (Inches of Water)																					
		.10		.20		.30		.40		.50		.60		.70		.80		.90		1.00	
CFM	RPM	BHP	RPM	BHP	RPM	BHP	RPM	BHP	RPM	BHP	RPM	BHP	RPM	BHP	RPM	BHP	RPM	BHP	RPM	BHP	
<b>2-HP Standard Motor &amp; Field Supplied Low Static Drive<sup>(1)</sup></b>																					
2720	—	—	590	0.55	633	0.66	674	0.77	713	0.89	750	1.01	786	1.14	818	1.28	850	1.42	879	1.56	
3060	602	0.62	643	0.72	682	0.83	719	0.96	756	1.09	791	1.23	825	1.36	857	1.50	889	1.65	917	1.80	
3400	660	0.82	698	0.94	733	1.05	767	1.18	801	1.32	834	1.48	866	1.62	897	1.77	927	1.92	956	2.08	
3740	718	1.06	754	1.19	787	1.32	818	1.45	849	1.60	880	1.76	910	1.92	939	2.08	968	2.24	996	2.41	
4080	777	1.35	811	1.49	841	1.63	870	1.77	899	1.92	928	2.08	956	2.26	983	2.43	1011	2.61	1037	2.79	
<b>2-HP Standard Motor &amp; Drive</b>												<b>3-HP Oversized Motor &amp; Drive</b>									

Continued

External Static Pressure (Inches of Water)																					
		1.10		1.20		1.30		1.40		1.50		1.60		1.70		1.80		1.90		2.00	
CFM	RPM	BHP	RPM	BHP	RPM	BHP	RPM	BHP	RPM	BHP	RPM	BHP	RPM	BHP	RPM	BHP	RPM	BHP	RPM	BHP	
<b>2-HP Standard Motor &amp; Drive</b>																					
2720	907	1.71	934	1.86	960	2.01	987	2.17	1014	2.33	1039	2.48	1063	2.64	1088	2.81	1112	2.97	1134	3.13	
3060	945	1.95	971	2.11	997	2.28	1022	2.45	1047	2.62	1070	2.79	1094	2.96	1117	3.14	1141	3.31	—	—	
3400	985	2.24	1010	2.40	1036	2.58	1060	2.76	1084	2.93	1106	3.11	1130	3.31	—	—	—	—	—	—	
3740	1023	2.58	1049	2.75	1075	2.93	1099	3.11	1122	3.29	—	—	—	—	—	—	—	—	—	—	
4080	1063	2.96	1089	3.15	1114	3.34	—	—	—	—	—	—	—	—	—	—	—	—	—	—	
<b>2-HP Standard Motor &amp; Drive</b>												<b>3-HP Oversized Motor &amp; Drive</b>									

For Standard Evaporator Fan Speed (RPM), reference [Table 123](#).

Notes:

Data includes pressure drop due to standard filters and wet coils. No accessories or options are included in pressure drop data.

Refer to [Table 128](#) to determine additional static pressure drop due to other options/accessories.

2-HP Fan Motor Heat (MBH) = 2.000 x Fan BHP + .5000. 3-HP Fan Motor Heat (MBH) = 2.900 x Fan BHP + .4750

Factory supplied motors, in commercial equipment, are definite purpose motors, specifically designed and tested to operate reliably and continuously at all cataloged conditions. Using the full horsepower range of our fan motors as shown in our tabular data will not result in nuisance tripping or premature motor failure. Our product's warranty will not be affected.

<sup>(1)</sup> Field Supplied Fan Sheave AK79 and Belt AX38 required.

**Table 114. Belt Drive Evaporator Fan Performance 8½ Tons with Gas Heat YHC102A3,4,W\*L Low Heat Horizontal Airflow**

External Static Pressure (Inches of Water)																					
		.10		.20		.30		.40		.50		.60		.70		.80		.90		1.00	
CFM	RPM	BHP	RPM	BHP	RPM	BHP	RPM	BHP	RPM	BHP	RPM	BHP	RPM	BHP	RPM	BHP	RPM	BHP	RPM	BHP	
<b>2-HP Standard Motor &amp; Field Supplied Low Static Drive<sup>(1)</sup></b>																					
2720	622	0.62	669	0.73	711	0.84	760	0.97	807	1.12	849	1.26	884	1.38	915	1.50	944	1.62	972	1.74	
3060	688	0.85	732	0.97	770	1.09	809	1.22	853	1.38	895	1.54	934	1.70	968	1.85	998	1.99	1026	2.13	
3400	756	1.14	795	1.27	832	1.40	866	1.54	901	1.69	941	1.86	979	2.04	1015	2.22	1049	2.40	1079	2.56	
3740	824	1.49	859	1.62	895	1.78	926	1.92	957	2.07	990	2.24	1025	2.42	1061	2.62	1095	2.82	1127	3.02	
4080	893	1.90	925	2.05	958	2.21	988	2.37	1017	2.53	1046	2.70	1075	2.88	1108	3.08	1140	3.29	—	—	
<b>2-HP Standard Motor &amp; Drive</b>												<b>3-HP Oversized Motor &amp; Drive</b>									

Continued

External Static Pressure (Inches of Water)																					
		1.10		1.20		1.30		1.40		1.50		1.60		1.70		1.80		1.90		2.00	
CFM	RPM	BHP	RPM	BHP	RPM	BHP	RPM	BHP	RPM	BHP	RPM	BHP	RPM	BHP	RPM	BHP	RPM	BHP	RPM	BHP	
<b>2-HP Standard Motor &amp; Drive</b>																					
2720	998	1.86	1024	1.98	1047	2.10	1071	2.22	1094	2.33	1115	2.45	1138	2.57	1159	2.69	1181	2.82	1201	2.94	
3060	1053	2.26	1078	2.39	1102	2.53	1125	2.66	1146	2.79	1169	2.93	1190	3.06	1210	3.19	1230	3.32	1250	3.45	
3400	1106	2.71	1131	2.86	1156	3.02	1179	3.16	1201	3.31	1223	3.45	—	—	—	—	—	—	—	—	
3740	1158	3.21	1185	3.39	—	—	—	—	—	—	—	—	—	—	—	—	—	—	—	—	
4080	—	—	—	—	—	—	—	—	—	—	—	—	—	—	—	—	—	—	—	—	
<b>2-HP Standard Motor &amp; Drive</b>												<b>3-HP Oversized Motor &amp; Drive</b>									

For Standard Evaporator Fan Speed (RPM), reference [Table 123](#).

Notes:

Data includes pressure drop due to standard filters and wet coils. No accessories or options are included in pressure drop data.

Refer to [Table 128](#) to determine additional static pressure drop due to other options/accessories.

2-HP Fan Motor Heat (MBH) = 2.000 x Fan BHP + .5000. 3-HP Fan Motor Heat (MBH) = 2.900 x Fan BHP + .4750.

Factory supplied motors, in commercial equipment, are definite purpose motors, specifically designed and tested to operate reliably and continuously at all cataloged conditions. Using the full horsepower range of our fan motors as shown in our tabular data will not result in nuisance tripping or premature motor failure. Our product's warranty will not be affected.

<sup>(1)</sup> Field Supplied Fan Sheave AK79 and Belt AX38 required.

## Performance Data

*(8½ Tons High Efficiency)*

**Table 115. Belt Drive Evaporator Fan Performance 8½ Tons with Gas Heat YHC102A3,4,W\*M Medium Heat Horizontal Airflow**

CFM	External Static Pressure (Inches of Water)																			
	.10		.20		.30		.40		.50		.60		.70		.80		.90		1.00	
	RPM	BHP	RPM	BHP	RPM	BHP	RPM	BHP	RPM	BHP	RPM	BHP	RPM	BHP	RPM	BHP	RPM	BHP	RPM	BHP
<b>2-HP Standard Motor &amp; Field Supplied Low Static Drive<sup>(1)</sup></b>																				
2720	625	0.62	671	0.73	714	0.84	763	0.98	809	1.13	851	1.27	885	1.39	917	1.51	946	1.63	974	1.75
3060	691	0.86	734	0.98	772	1.10	812	1.23	856	1.39	897	1.55	936	1.71	970	1.86	1001	2.00	1028	2.14
3400	759	1.15	798	1.28	835	1.41	868	1.55	904	1.70	943	1.87	982	2.05	1019	2.23	1052	2.41	1082	2.57
3740	827	1.50	863	1.64	898	1.79	930	1.94	960	2.09	994	2.26	1029	2.44	1064	2.64	1098	2.84	1130	3.03
4080	897	1.92	929	2.07	962	2.23	992	2.39	1021	2.55	1049	2.72	1079	2.90	1112	3.10	1144	3.31	—	—
<b>2-HP Standard Motor &amp; Drive</b>										<b>3-HP Oversized Motor &amp; Drive</b>										

Continued

CFM	External Static Pressure (Inches of Water)																			
	1.10		1.20		1.30		1.40		1.50		1.60		1.70		1.80		1.90		2.00	
	RPM	BHP	RPM	BHP	RPM	BHP	RPM	BHP	RPM	BHP	RPM	BHP	RPM	BHP	RPM	BHP	RPM	BHP	RPM	BHP
<b>2-HP Standard Motor &amp; Drive</b>																				
2720	1000	1.87	1025	1.99	1048	2.10	1072	2.22	1095	2.34	1117	2.46	1139	2.58	1161	2.70	1182	2.82	1203	2.95
3060	1054	2.27	1080	2.41	1103	2.53	1126	2.67	1149	2.80	1170	2.93	1192	3.07	1211	3.20	1231	3.33	—	—
3400	1108	2.73	1134	2.88	1158	3.03	1181	3.17	1204	3.33	—	—	—	—	—	—	—	—	—	—
3740	1160	3.23	1187	3.41	—	—	—	—	—	—	—	—	—	—	—	—	—	—	—	—
4080	—	—	—	—	—	—	—	—	—	—	—	—	—	—	—	—	—	—	—	—
<b>2-HP Standard Motor &amp; Drive</b>										<b>3-HP Oversized Motor &amp; Drive</b>										

For Standard Evaporator Fan Speed (RPM), reference [Table 123](#).

Notes:

Data includes pressure drop due to standard filters and wet coils. No accessories or options are included in pressure drop data.

Refer to [Table 128](#) to determine additional static pressure drop due to other options/accessories.

2-HP Fan Motor Heat (MBH) = 2.000 x Fan BHP + .5000. 3-HP Fan Motor Heat (MBH) = 2.900 x Fan BHP + .4750

Factory supplied motors, in commercial equipment, are definite purpose motors, specifically designed and tested to operate reliably and continuously at all cataloged conditions. Using the full horsepower range of our fan motors as shown in our tabular data will not result in nuisance tripping or premature motor failure. Our product's warranty will not be affected.

<sup>(1)</sup> Field Supplied Fan Sheave AK79 and Belt AX38 required.

**Table 116. Belt Drive Evaporator Fan Performance 8½ Tons with Gas Heat YHC102A3,4,W\*H High Heat Horizontal Airflow**

CFM	External Static Pressure (Inches of Water)																			
	.10		.20		.30		.40		.50		.60		.70		.80		.90		1.00	
	RPM	BHP	RPM	BHP	RPM	BHP	RPM	BHP	RPM	BHP	RPM	BHP	RPM	BHP	RPM	BHP	RPM	BHP	RPM	BHP
<b>2-HP Standard Motor &amp; Field Supplied Low Static Drive<sup>(1)</sup></b>										<b>2-HP Standard Motor &amp; Drive</b>										
2720	640	0.66	684	0.77	729	0.89	778	1.03	823	1.17	863	1.31	896	1.43	926	1.55	955	1.67	982	1.79
3060	709	0.91	750	1.03	788	1.15	829	1.29	872	1.45	913	1.61	950	1.77	983	1.92	1011	2.05	1038	2.19
3400	778	1.21	817	1.35	851	1.48	885	1.62	924	1.78	963	1.96	1000	2.14	1035	2.30	1067	2.49	1095	2.65
3740	848	1.58	885	1.73	917	1.88	948	2.03	979	2.18	1014	2.36	1050	2.56	1084	2.76	1118	2.96	1148	3.15
4080	919	2.02	952	2.18	984	2.35	1012	2.50	1041	2.67	1070	2.84	1102	3.04	1135	3.25	—	—	—	—
<b>2-HP Standard Motor &amp; Drive</b>										<b>3-HP Oversized Motor &amp; Drive</b>										

Continued

CFM	External Static Pressure (Inches of Water)																			
	1.10		1.20		1.30		1.40		1.50		1.60		1.70		1.80		1.90		2.00	
	RPM	BHP	RPM	BHP	RPM	BHP	RPM	BHP	RPM	BHP	RPM	BHP	RPM	BHP	RPM	BHP	RPM	BHP	RPM	BHP
<b>2-HP Standard Motor &amp; Drive</b>																				
2720	1007	1.90	1032	2.02	1056	2.14	1079	2.26	1101	2.38	1124	2.50	1146	2.62	1167	2.74	1189	2.86	1209	2.98
3060	1064	2.32	1090	2.46	1113	2.59	1135	2.72	1157	2.85	1178	2.98	1199	3.12	1220	3.26	1240	3.39	—	—
3400	1121	2.80	1146	2.95	1170	3.10	1193	3.25	1215	3.40	—	—	—	—	—	—	—	—	—	—
3740	1177	3.34	—	—	—	—	—	—	—	—	—	—	—	—	—	—	—	—	—	—
4080	—	—	—	—	—	—	—	—	—	—	—	—	—	—	—	—	—	—	—	—
<b>2-HP Standard Motor &amp; Drive</b>										<b>3-HP Oversized Motor &amp; Drive</b>										

For Standard Evaporator Fan Speed (RPM), reference [Table 123](#).

Notes:

Data includes pressure drop due to standard filters and wet coils. No accessories or options are included in pressure drop data.

Refer to [Table 128](#) to determine additional static pressure drop due to other options/accessories.

2-HP Fan Motor Heat (MBH) = 2.000 x Fan BHP + .5000. 3-HP Fan Motor Heat (MBH) = 2.900 x Fan BHP + .4750

Factory supplied motors, in commercial equipment, are definite purpose motors, specifically designed and tested to operate reliably and continuously at all cataloged conditions. Using the full horsepower range of our fan motors as shown in our tabular data will not result in nuisance tripping or premature motor failure. Our product's warranty will not be affected.

<sup>(1)</sup> Field Supplied Fan Sheave AK79 and Belt AX38 required.

## Performance Data

*(10 Tons High Efficiency)*

**Table 117. Belt Drive Evaporator Fan Performance 10 Tons with Optional Electric Heat THC102A3,4,W Downflow Airflow**

CFM	External Static Pressure (Inches of Water)																				
	.10		.20		.30		.40		.50		.60		.70		.80		.90		1.00		
	RPM	BHP	RPM	BHP	RPM	BHP	RPM	BHP	RPM	BHP	RPM	BHP	RPM	BHP	RPM	BHP	RPM	BHP	RPM	BHP	
<b>3-HP Standard Motor &amp; Low Static Drive Accessory Kit<sup>(1)</sup></b>																					
2000*	—	—	—	—	—	—	568	0.43	613	0.53	653	0.64	691	0.75	727	0.86	763	0.98	797	1.10	
2400*	—	—	—	—	—	—	606	0.56	650	0.67	691	0.78	728	0.90	763	1.02	796	1.16	826	1.29	
2800*	—	—	564	0.50	607	0.60	649	0.71	689	0.83	728	0.95	766	1.08	801	1.21	833	1.35	864	1.50	
3200	576	0.57	618	0.67	659	0.79	697	0.90	734	1.03	770	1.17	804	1.31	839	1.45	871	1.60	901	1.74	
3600	638	0.78	675	0.89	714	1.02	749	1.14	782	1.27	815	1.41	847	1.57	879	1.73	909	1.89	939	2.04	
4000	701	1.04	734	1.16	768	1.30	803	1.44	834	1.58	863	1.72	894	1.87	923	2.04	952	2.21	979	2.39	
4400	764	1.36	795	1.49	825	1.63	857	1.79	888	1.95	916	2.10	943	2.25	970	2.41	997	2.59	1024	2.78	
4800	828	1.74	857	1.88	884	2.02	913	2.18	942	2.36	970	2.53	996	2.70	1021	2.86	1045	3.03	1070	3.22	
<b>3-HP Standard Motor &amp; Drive</b>																					

Continued

CFM	External Static Pressure (Inches of Water)																				
	1.10		1.20		1.30		1.40		1.50		1.60		1.70		1.80		1.90		2.00		
	RPM	BHP	RPM	BHP	RPM	BHP	RPM	BHP	RPM	BHP	RPM	BHP	RPM	BHP	RPM	BHP	RPM	BHP	RPM	BHP	
<b>3-HP Oversized Motor &amp; Drive</b>																					
2000*	828	1.22	859	1.35	888	1.48	917	1.61	945	1.75	971	1.88	998	2.03	1023	2.19	1048	2.35	1072	2.50	
2400*	858	1.43	888	1.56	916	1.70	945	1.85	972	1.99	998	2.14	1023	2.29	1050	2.45	1073	2.60	1097	2.76	
2800*	894	1.65	921	1.79	949	1.95	975	2.11	1001	2.27	1027	2.43	1051	2.59	1076	2.75	1100	2.92	1123	3.09	
3200	931	1.89	959	2.06	986	2.22	1012	2.39	1037	2.56	1061	2.74	1084	2.91	1108	3.09	1131	3.28	1153	3.46	
3600	969	2.21	997	2.37	1024	2.54	1050	2.72	1074	2.89	1098	3.08	1122	3.27	1145	3.46	1166	3.65	1188	3.85	
4000	1007	2.57	1034	2.74	1062	2.93	1087	3.11	1112	3.29	1136	3.47	1159	3.66	1182	3.86	1204	4.07	1226	4.28	
4400	1050	2.97	1075	3.17	1101	3.36	1126	3.55	1150	3.75	1173	3.94	1198	4.15	1219	4.34	1241	4.54	1264	4.77	
4800	1095	3.42	1119	3.62	1143	3.83	1166	4.05	1189	4.26	1212	4.47	1235	4.68	1258	4.90	1280	5.12	1300	5.32	
<b>5-HP Oversized Motor &amp; Drive</b>																					

For Standard Evaporator Fan Speed (RPM), reference [Table 123](#).

Table includes Dehumidification (Hot Gas Reheat Option).

Notes:

Data includes pressure drop due to standard filters and wet coils. Data does not include pressure drop due to reheat coil.

No accessories or options are included in pressure drop data.

Refer to [Table 128](#) to determine additional static pressure drop due to other options/accessories.

3-HP Fan Motor Heat (MBH) = 2.900 x Fan BHP+.475. 5-HP Fan Motor Heat (MBH) = 2.950 x Fan BHP+.470.

Factory supplied motors, in commercial equipment, are definite purpose motors, specifically designed and tested to operate reliably and continuously at all cataloged conditions. Using the full horsepower range of our fan motors as shown in our tabular data will not result in nuisance tripping or premature motor failure. Our product's warranty will not be affected.

\*For 2000, 2400 and 2800 CFM, unit applications below 320 CFM/Ton are only applicable to T\_C models only (No Gas Heat). See below for restrictions.

- Electric heaters restricted on applications below 320 CFM/Ton.
- Dehumidification (Hot Gas Reheat) or TXV with Froststat and Crankcase Heaters are required on applications below 320 CFM/Ton.

<sup>(1)</sup> BAYLSDR010A required.

## Performance Data

*(10 Tons High Efficiency)*

**Table 118. Belt Drive Evaporator Fan Performance 10 Tons with Optional Electric Heat THC102A3,4,W Horizontal Airflow**

CFM	External Static Pressure (Inches of Water)																				
	.10		.20		.30		.40		.50		.60		.70		.80		.90		1.00		
	RPM	BHP	RPM	BHP	RPM	BHP	RPM	BHP	RPM	BHP	RPM	BHP	RPM	BHP	RPM	BHP	RPM	BHP	RPM	BHP	
<b>3-HP Standard Motor &amp; Low Static Drive Accessory Kit<sup>(i)</sup></b>																					
2000*	—	—	—	—	584	0.43	639	0.53	682	0.62	721	0.71	755	0.79	787	0.88	818	0.97	849	1.06	
2400*	—	—	578	0.48	627	0.57	683	0.70	734	0.83	776	0.94	812	1.05	845	1.15	876	1.26	904	1.36	
2800*	596	0.58	640	0.67	686	0.79	728	0.90	776	1.04	822	1.19	865	1.34	900	1.47	932	1.60	962	1.73	
3200	671	0.85	706	0.93	748	1.06	787	1.19	824	1.32	864	1.47	906	1.64	946	1.81	983	1.97	1015	2.13	
3600	746	1.18	777	1.27	811	1.39	849	1.54	883	1.68	916	1.82	950	1.98	987	2.16	1024	2.35	1060	2.55	
4000	822	1.59	850	1.70	879	1.81	912	1.95	946	2.12	977	2.28	1006	2.43	1035	2.60	1067	2.79	1101	2.99	
4400	898	2.09	925	2.21	950	2.32	977	2.46	1008	2.63	1039	2.81	1067	2.98	1094	3.16	1121	3.33	1147	3.52	
4800	974	2.69	1000	2.83	1023	2.95	1046	3.07	1072	3.23	1101	3.42	1130	3.62	1156	3.81	1181	4.00	1206	4.19	
<b>3-HP Standard Motor &amp; Drive</b>												<b>5-HP Oversized Motor &amp; Drive</b>									

Continued

CFM	External Static Pressure (Inches of Water)																				
	1.10		1.20		1.30		1.40		1.50		1.60		1.70		1.80		1.90		2.00		
	RPM	BHP	RPM	BHP	RPM	BHP	RPM	BHP	RPM	BHP	RPM	BHP	RPM	BHP	RPM	BHP	RPM	BHP	RPM	BHP	
<b>3-HP Standard Motor &amp; Low Static Drive Accessory Kit<sup>(i)</sup></b>										<b>3-HP Standard Motor &amp; Drive</b>											
2000*	877	1.15	906	1.24	933	1.33	961	1.43	988	1.54	1014	1.64	1038	1.74	1063	1.85	1087	1.96	1111	2.07	
2400*	931	1.47	958	1.58	983	1.68	1008	1.78	1032	1.89	1056	2.00	1080	2.11	1103	2.22	1126	2.34	1149	2.46	
2800*	989	1.84	1015	1.97	1040	2.09	1064	2.21	1087	2.34	1110	2.46	1132	2.58	1154	2.71	1176	2.83	1196	2.95	
3200	1044	2.28	1072	2.42	1097	2.57	1122	2.71	1145	2.84	1168	2.99	1189	3.12	1210	3.27	1231	3.41	1250	3.54	
3600	1093	2.74	1124	2.92	1151	3.09	1176	3.25	1201	3.42	1224	3.58	1246	3.74	1268	3.90	1289	4.06	1308	4.20	
4000	1135	3.21	1167	3.42	1198	3.63	1227	3.84	1254	4.05	1278	4.23	1301	4.41	1323	4.60	1344	4.77	1365	4.95	
4400	1177	3.73	1207	3.96	1239	4.19	1268	4.42	1297	4.67	1324	4.90	1351	5.12	1376	5.35	1398	5.56	1420	5.75	
4800	1229	4.39	1254	4.59	1282	4.83	1310	5.07	1338	5.32	1365	5.58	—	—	—	—	—	—	—	—	
<b>5-HP Oversized Motor &amp; Drive</b>																					

For Standard Evaporator Fan Speed (RPM), reference [Table 123](#).

Table includes Dehumidification (Hot Gas Reheat Option).

Notes:

Data includes pressure drop due to standard filters and wet coils. Data does not include pressure drop due to reheat coil.

No accessories or options are included in pressure drop data.

Refer to [Table 128](#) to determine additional static pressure drop due to other options/accessories.

3-HP Fan Motor Heat (MBH) = 2.900 x Fan BHP+.475. 5-HP Fan Motor Heat (MBH) = 2.950 x Fan BHP+.470.

Factory supplied motors, in commercial equipment, are definite purpose motors, specifically designed and tested to operate reliably and continuously at all cataloged conditions. Using the full horsepower range of our fan motors as shown in our tabular data will not result in nuisance tripping or premature motor failure. Our product's warranty will not be affected.

\*For 2000, 2400 and 2800 CFM, unit applications below 320 CFM/Ton are only applicable to T\_C models only (No Gas Heat). See below for restrictions.

- Electric heaters restricted on applications below 320 CFM/Ton.
- Dehumidification (Hot Gas Reheat) or TXV with Froststat and Crankcase Heaters are required on applications below 320 CFM/Ton.

<sup>(i)</sup> BAYLSDR010A required.

<sup>(ii)</sup> BAYLSDR010A required.

## Performance Data

*(10 Tons High Efficiency)*

**Table 119. Belt Drive Evaporator Fan Performance 10 Tons with Gas Heat YHC120A3,4,W\*L,M Low & Medium Heat Downflow Airflow**

CFM	External Static Pressure (Inches of Water)																			
	.10		.20		.30		.40		.50		.60		.70		.80		.90		1.00	
	RPM	BHP	RPM	BHP	RPM	BHP	RPM	BHP	RPM	BHP	RPM	BHP	RPM	BHP	RPM	BHP	RPM	BHP	RPM	BHP
<b>3-HP Standard Motor &amp; Field Supplied Low Static Drive<sup>(1)</sup></b>																				
3200	—	—	—	—	—	—	743	1.06	779	1.20	814	1.35	847	1.49	879	1.63	910	1.78	938	1.93
3600	—	—	735	1.10	768	1.22	802	1.36	834	1.50	866	1.66	897	1.82	927	1.98	957	2.14	985	2.30
4000	767	1.29	802	1.44	833	1.58	863	1.71	892	1.87	922	2.04	951	2.21	979	2.39	1006	2.56	1034	2.74
4400	837	1.69	869	1.85	899	2.00	926	2.15	953	2.31	980	2.48	1007	2.66	1033	2.85	1059	3.04	1085	3.24
4800	908	2.16	937	2.33	965	2.50	991	2.67	1017	2.83	1041	3.00	1066	3.19	1090	3.38	1115	3.59	1139	3.80
<b>3-HP Standard Motor &amp; Drive</b>															<b>5-HP Oversized Motor &amp; Drive</b>					

Continued

CFM	External Static Pressure (Inches of Water)																			
	1.10		1.20		1.30		1.40		1.50		1.60		1.70		1.80		1.90		2.00	
	RPM	BHP	RPM	BHP	RPM	BHP	RPM	BHP	RPM	BHP	RPM	BHP	RPM	BHP	RPM	BHP	RPM	BHP	RPM	BHP
<b>3-HP Standard Motor &amp; Drive</b>																				
3200	966	2.10	992	2.26	1018	2.43	1042	2.60	1066	2.78	1091	2.96	1114	3.15	1136	3.33	1159	3.51	1182	3.70
3600	1013	2.47	1039	2.64	1065	2.82	1089	3.00	1113	3.19	1135	3.38	1157	3.56	1179	3.76	1201	3.97	1221	4.16
4000	1060	2.92	1086	3.10	1111	3.28	1135	3.47	1159	3.66	1182	3.86	1203	4.05	1224	4.26	1246	4.47	1266	4.68
4400	1110	3.43	1134	3.62	1159	3.82	1183	4.02	1205	4.22	1229	4.43	1251	4.64	1272	4.84	1292	5.05	1313	5.27
4800	1162	4.01	1185	4.22	1209	4.44	1231	4.64	1253	4.86	1276	5.07	1298	5.30	1319	5.51	1338	5.73	—	—
<b>3-HP Standard Motor &amp; Drive</b>															<b>5-HP Oversized Motor &amp; Drive</b>					

For Standard Evaporator Fan Speed (RPM), reference [Table 123](#).

Notes:

Data includes pressure drop due to standard filters and wet coils. No accessories or options are included in pressure drop data.

Refer to [Table 128](#) to determine additional static pressure drop due to other options/accessories.

3-HP Fan Motor Heat (MBH) = 2.900 x Fan BHP+.475. 5-HP Fan Motor Heat (MBH) = 2.950 x Fan BHP+.470.

Factory supplied motors, in commercial equipment, are definite purpose motors, specifically designed and tested to operate reliably and continuously at all cataloged conditions. Using the full horsepower range of our fan motors as shown in our tabular data will not result in nuisance tripping or premature motor failure. Our product's warranty will not be affected.

<sup>(1)</sup> Field Supplied Motor Sheave 1VM50 x 7/8 inch, Fan Sheave AK89, and Belt AX40 required.

**Table 120. Belt Drive Evaporator Fan Performance 10 Tons with Gas Heat YHC120A3,4,W\*H High Heat Downflow Airflow**

CFM	External Static Pressure (Inches of Water)																			
	.10		.20		.30		.40		.50		.60		.70		.80		.90		1.00	
	RPM	BHP	RPM	BHP	RPM	BHP	RPM	BHP	RPM	BHP	RPM	BHP	RPM	BHP	RPM	BHP	RPM	BHP	RPM	BHP
<b>3-HP Standard Motor &amp; Field Supplied Low Static Drive<sup>(1)</sup></b>																				
3200	—	—	—	—	739	1.05	774	1.19	809	1.33	843	1.47	874	1.61	905	1.76	935	1.92	963	2.08
3600	738	1.11	772	1.23	805	1.37	838	1.52	869	1.68	900	1.84	930	2.00	960	2.16	988	2.32	1016	2.49
4000	813	1.49	844	1.63	873	1.77	903	1.93	932	2.10	961	2.27	989	2.45	1017	2.63	1043	2.80	1070	2.98
4400	889	1.95	917	2.10	944	2.25	971	2.42	998	2.59	1024	2.78	1050	2.97	1076	3.17	1101	3.37	1126	3.56
4800	964	2.50	991	2.66	1016	2.83	1040	3.00	1065	3.18	1090	3.38	1114	3.58	1138	3.79	1161	4.00	1184	4.22
<b>3-HP Standard Motor &amp; Drive</b>															<b>5-HP Oversized Motor &amp; Drive</b>					

Continued

CFM	External Static Pressure (Inches of Water)																			
	1.10		1.20		1.30		1.40		1.50		1.60		1.70		1.80		1.90		2.00	
	RPM	BHP	RPM	BHP	RPM	BHP	RPM	BHP	RPM	BHP	RPM	BHP	RPM	BHP	RPM	BHP	RPM	BHP	RPM	BHP
<b>3-HP Standard Motor &amp; Drive</b>																				
3200	989	2.24	1015	2.41	1039	2.58	1064	2.76	1087	2.93	1111	3.12	1133	3.30	1156	3.48	1179	3.68	1200	3.85
3600	1042	2.66	1067	2.84	1091	3.02	1115	3.21	1138	3.40	1160	3.59	1181	3.78	1203	3.98	1224	4.19	1244	4.39
4000	1095	3.17	1120	3.35	1145	3.54	1167	3.73	1190	3.93	1212	4.14	1233	4.35	1253	4.55	1273	4.76	1293	4.97
4400	1150	3.75	1174	3.95	1197	4.15	1221	4.36	1243	4.56	1265	4.77	1285	4.97	1306	5.20	1326	5.42	1345	5.65
4800	1208	4.42	1231	4.64	1253	4.86	1275	5.07	1297	5.29	1317	5.50	1338	5.72	—	—	—	—	—	—
<b>3-HP Standard Motor &amp; Drive</b>															<b>5-HP Oversized Motor &amp; Drive</b>					

For Standard Evaporator Fan Speed (RPM), reference [Table 123](#).

Notes:

Data includes pressure drop due to standard filters and wet coils. No accessories or options are included in pressure drop data.

Refer to [Table 128](#) to determine additional static pressure drop due to other options/accessories.

3-HP Fan Motor Heat (MBH) = 2.900 x Fan BHP+.475. 5-HP Fan Motor Heat (MBH) = 2.950 x Fan BHP+.470.

Factory supplied motors, in commercial equipment, are definite purpose motors, specifically designed and tested to operate reliably and continuously at all cataloged conditions. Using the full horsepower range of our fan motors as shown in our tabular data will not result in nuisance tripping or premature motor failure. Our product's warranty will not be affected.

<sup>(1)</sup> Field Supplied Motor Sheave 1VM50 x 7/8 inch, Fan Sheave AK89, and Belt AX40 required.

## Performance Data

*(10 Tons High Efficiency)*

**Table 121. Belt Drive Evaporator Fan Performance 10 Tons with Gas Heat YHC120A3,4,W\*L,M Low & Medium Heat Horizontal Airflow**

External Static Pressure (Inches of Water)																					
		.10		.20		.30		.40		.50		.60		.70		.80		.90		1.00	
CFM	RPM	BHP	RPM	BHP	RPM	BHP	RPM	BHP	RPM	BHP	RPM	BHP	RPM	BHP	RPM	BHP	RPM	BHP	RPM	BHP	
<b>3-HP Standard Motor &amp; Field Supplied Low Static Drive<sup>(1)</sup></b>											<b>3-HP Standard Motor &amp; Drive</b>										
3200	—	—	777	1.15	814	1.28	853	1.42	895	1.59	936	1.76	973	1.93	1008	2.09	1037	2.24	1064	2.38	
3600	819	1.42	857	1.57	890	1.71	922	1.85	957	2.02	994	2.20	1032	2.39	1067	2.58	1099	2.77	1131	2.96	
4000	902	1.91	936	2.07	968	2.23	998	2.39	1027	2.55	1058	2.73	1091	2.93	1124	3.14	1158	3.36	1189	3.57	
4400	986	2.50	1016	2.68	1047	2.86	1075	3.03	1101	3.20	1128	3.39	1155	3.58	1186	3.80	1217	4.03	1246	4.25	
4800	1070	3.22	1098	3.40	1127	3.60	1153	3.79	1178	3.98	1203	4.17	1227	4.37	1251	4.57	1279	4.80	1307	5.05	
<b>5-HP Oversized Motor &amp; Drive</b>																					

Continued

External Static Pressure (Inches of Water)																					
		1.10		1.20		1.30		1.40		1.50		1.60		1.70		1.80		1.90		2.00	
CFM	RPM	BHP	RPM	BHP	RPM	BHP	RPM	BHP	RPM	BHP	RPM	BHP	RPM	BHP	RPM	BHP	RPM	BHP	RPM	BHP	
<b>3-HP Standard Motor &amp; Drive</b>																					
3200	1090	2.53	1115	2.67	1139	2.81	1161	2.95	1183	3.09	1205	3.23	1225	3.37	1246	3.51	1265	3.65	1284	3.78	
3600	1157	3.13	1181	3.29	1205	3.45	1228	3.61	1250	3.77	1272	3.93	1293	4.09	1312	4.24	1331	4.40	1351	4.56	
4000	1218	3.78	1246	3.99	1271	4.18	1294	4.36	1317	4.55	1338	4.72	1360	4.91	1379	5.07	1398	5.25	1418	5.43	
4400	1276	4.49	1304	4.73	1333	4.97	1359	5.20	1383	5.42	1405	5.62	—	—	—	—	—	—	—	—	
4800	1336	5.30	1363	5.56	—	—	—	—	—	—	—	—	—	—	—	—	—	—	—	—	
<b>5-HP Oversized Motor &amp; Drive</b>																					

For Standard Evaporator Fan Speed (RPM), reference [Table 123](#).

Notes:

Data includes pressure drop due to standard filters and wet coils. No accessories or options are included in pressure drop data.

Refer to [Table 128](#) to determine additional static pressure drop due to other options/accessories.

3-HP Fan Motor Heat (MBH) = 2.900 x Fan BHP+.475. 5-HP Fan Motor Heat (MBH) = 2.950 x Fan BHP+.470.

Factory supplied motors, in commercial equipment, are definite purpose motors, specifically designed and tested to operate reliably and continuously at all cataloged conditions. Using the full horsepower range of our fan motors as shown in our tabular data will not result in nuisance tripping or premature motor failure. Our product's warranty will not be affected.

<sup>(1)</sup> Field Supplied Motor Sheave 1VM50 x 7/8 inch, Fan Sheave AK89, and Belt AX40 required.

**Table 122. Belt Drive Evaporator Fan Performance 10 Tons with Gas Heat YHC120A3,4,W\*H High Heat Horizontal Airflow**

External Static Pressure (Inches of Water)																					
		.10		.20		.30		.40		.50		.60		.70		.80		.90		1.00	
CFM	RPM	BHP	RPM	BHP	RPM	BHP	RPM	BHP	RPM	BHP	RPM	BHP	RPM	BHP	RPM	BHP	RPM	BHP	RPM	BHP	
<b>3-HP Standard Motor &amp; Field Supplied Low Static Drive<sup>(1)</sup></b>											<b>3-HP Standard Motor &amp; Drive</b>										
3200	785	1.18	821	1.31	861	1.46	903	1.62	944	1.80	981	1.96	1014	2.12	1043	2.27	1070	2.41	1095	2.55	
3600	874	1.64	907	1.78	939	1.93	977	2.11	1014	2.30	1050	2.49	1084	2.69	1115	2.87	1144	3.05	1169	3.21	
4000	964	2.21	994	2.37	1023	2.53	1053	2.71	1087	2.91	1121	3.12	1154	3.33	1185	3.55	1215	3.76	1242	3.96	
4400	1055	2.91	1082	3.08	1109	3.25	1135	3.43	1164	3.64	1194	3.86	1225	4.09	1255	4.32	1284	4.56	1312	4.79	
4800	1146	3.74	1171	3.92	1196	4.11	1220	4.31	1244	4.51	1271	4.73	1298	4.97	1327	5.22	1354	5.47	1382	5.74	
<b>5-HP Oversized Motor &amp; Drive</b>																					

Continued

External Static Pressure (Inches of Water)																					
		1.10		1.20		1.30		1.40		1.50		1.60		1.70		1.80		1.90		2.00	
CFM	RPM	BHP	RPM	BHP	RPM	BHP	RPM	BHP	RPM	BHP	RPM	BHP	RPM	BHP	RPM	BHP	RPM	BHP	RPM	BHP	
<b>3-HP Standard Motor &amp; Drive</b>																					
3200	1120	2.70	1143	2.84	1166	2.98	1188	3.12	1208	3.25	1229	3.39	1249	3.53	1269	3.67	1289	3.82	1308	3.96	
3600	1194	3.37	1217	3.53	1240	3.69	1262	3.85	1282	4.01	1303	4.17	1322	4.32	1341	4.48	1361	4.64	1378	4.79	
4000	1269	4.16	1292	4.34	1314	4.52	1335	4.70	1356	4.88	1377	5.06	1397	5.24	1415	5.41	—	—	—	—	
4400	1339	5.02	1365	5.25	1388	5.47	1410	5.67	—	—	—	—	—	—	—	—	—	—	—	—	
4800	—	—	—	—	—	—	—	—	—	—	—	—	—	—	—	—	—	—	—	—	
<b>5-HP Oversized Motor &amp; Drive</b>																					

For Standard Evaporator Fan Speed (RPM), reference [Table 123](#).

Notes:

Data includes pressure drop due to standard filters and wet coils. No accessories or options are included in pressure drop data.

Refer to [Table 128](#) to determine additional static pressure drop due to other options/accessories.

3-HP Fan Motor Heat (MBH) = 2.900 x Fan BHP+.475. 5-HP Fan Motor Heat (MBH) = 2.950 x Fan BHP+.470.

Factory supplied motors, in commercial equipment, are definite purpose motors, specifically designed and tested to operate reliably and continuously at all cataloged conditions. Using the full horsepower range of our fan motors as shown in our tabular data will not result in nuisance tripping or premature motor failure. Our product's warranty will not be affected.

<sup>(1)</sup> Field Supplied Motor Sheave 1VM50 x 7/8 inch, Fan Sheave AK89, and Belt AX40 required



## Performance Data

**Table 123. Standard Motor & Sheave/Fan Speed (Rpm)**

Tons	Unit Model Number	6 Turns Open	5 Turns Open	4 Turns Open	3 Turns Open	2 Turns Open	1 Turn Open	Closed
3	T/Y*C036/033A	N/A	745	819	894	968	1043	1117
4	T/Y*C048A/043	N/A	833	916	1000	1083	1167	1250
5	T/Y*C060A/063	N/A	897	987	1077	1166	1256	1346
6	T/Y*C072A	N/A	723	779	835	890	946	1002
7½	T/YSC090,092A	N/A	835	891	946	1002	1057	1113
8½	T/Y*C102A	N/A	787	847	908	968	1029	1089
10	T/Y*C120A	N/A	908	969	1029	1090	1150	1211

Factory set at 3 turns open.

\* Indicates both standard and high efficiency units and both ReliaTel and Electromechanical controls.

**Table 124. Standard Motor & Low Static Drive Accessory Sheave/Fan Speed (Rpm)**

Tons	Unit Model Number	Fan Sheave	5 Turns Open	4 Turns Open	3 Turns Open	2 Turns Open	1 Turn Open	Closed
3	THC033A	AK84x3/4"	427	470	512	555	597	640
		AK69x3/4"	522	574	627	679	732	784
4	THC043A	AK79x3/4"	455	500	546	591	637	682
		AK61x3/4"	593	652	712	771	831	890
5	THC063A	AK71x3/4"	507	558	609	659	710	761
		AK59x3/4"	614	675	737	798	860	921
7½	THC092A	AK99x1"	462	498	533	569	604	640
		AK79x1"	582	627	672	716	761	806
8½	THC102A	AK99x1"	462	498	533	569	604	640
		AK79x1"	582	627	672	716	761	806
10	THC120A	AK94x1"	563	600	638	675	713	750
		AK74x1"	719	767	815	862	910	958

Factory set at 3 turns open.

**Table 125. Standard Motor & High Static Drive Accessory Sheave/Fan Speed (Rpm)**

Tons	Unit Model Number	6 Turns Open	5 Turns Open	4 Turns Open	3 Turns Open	2 Turns Open	1 Turn Open	Closed
6	T/Y*C072A3,A4,AW	N/A	831	895	959	1022	1086	1150
6	T/YSC072AK	N/A	958	1022	1086	1150	1214	1278
7½	T/YSC090,092A	N/A	958	1022	1086	1150	1214	1278

Factory set at 3 turns open.

\* Indicates both standard and high efficiency units and both ReliaTel and Electromechanical controls.

**Table 126. Oversized Motor & Drive Sheave/Fan Speed (Rpm)**

Tons	Unit Model Number	6 Turns Open	5 Turns Open	4 Turns Open	3 Turns Open	2 Turns Open	1 Turn Open	Closed
6	T/Y*C072A3,A4,AW	N/A	958	1022	1086	1150	1214	1278
7½	T/YSC090,T*C092A	N/A	1068	1150	1232	1315	1397	1479
8½	T/Y*C102A	N/A	958	1022	1086	1150	1214	1278
10	T/Y*C120A	1050	1135	1200	1275	1350	1425	N/A

Factory set at 3 turns open.

\* Indicates both standard and high efficiency units and both ReliaTel and Electromechanical controls.

## Performance Data

**Table 127. Outdoor Sound Power Level - dB (ref. 10 - 12 Watts)**

Tons	Unit Model	Octave Center Frequency								Overall dBA
	Number	63	125	250	500	1000	2000	4000	8000	
3	T/YSC036A	86	83	81	80	78	74	69	68	83
	T/YHC033A	86	83	81	80	78	74	69	68	83
4	T/YSC048A3,A4,AW	90	84	78	77	76	72	70	68	82
	T/YHC043A	92	86	83	82	81	75	72	69	85
5	T/YSC060A	94	87	83	82	79	75	73	69	84
	T/YHC063A	94	87	82	81	78	74	72	69	84
6	T/YSC072A	90	94	90	87	83	78	74	67	88
	T/YHC072A	91	95	90	87	84	79	75	68	89
7½	T/YSC090A	92	95	91	88	84	80	75	68	90
	T/YSC092A	89	93	88	85	81	76	72	66	87
	T/YHC092A	92	96	92	89	85	80	76	69	91
8½	T/YSC102A	88	92	87	84	80	75	72	65	86
	T/YHC102A	91	95	90	87	84	79	75	68	89
10	T/YSC120A	91	88	84	82	81	76	73	67	86
	T/YHC120A	94	89	87	85	84	78	75	69	88

Tests follow ARI270-95.

\* Indicates both standard and high efficiency units and both ReliaTel and Electromechanical controls.

**Table 128. Static Pressure Drop Through Accessories (Inches Water Column) — 3-10 Tons**

Tons	Unit Model Number	CFM	Standard Filters <sup>(iii)</sup>	Through Reheat Coil (WC)	2" Pleated Filter	Economizer with OA/RA Dampers <sup>(i)</sup>				Electric Heater Accessory (kW) <sup>(ii)</sup>			
						100% OA	100% RA	100% OA	100% RA	5-6	9-15	17-36	54
						Downflow		Horizontal					
3	T/YSC036A	960	0.03	—	0.05	0.05	0.01	0.05	0.00	.013	.016	.019	—
		1200	0.04	—	0.07	0.07	0.02	0.07	0.01	.020	.025	.030	—
		1440	0.06	—	0.10	0.10	0.03	0.10	0.01	.029	.036	.043	—
	T/YHC033A (13 SEER)	600	0.01	.01	0.03	0.03	0.01	0.03	0.00	—	—	—	—
		960	0.02	.03	0.04	0.05	0.01	0.05	0.00	.013	.016	.019	—
		1200	0.03	.04	0.05	0.07	0.02	0.07	0.01	.020	.025	.030	—
4	T/YSC048A	1280	0.04	—	0.06	0.08	0.03	0.08	0.01	.023	.029	.034	—
		1600	0.05	—	0.09	0.12	0.04	0.12	0.01	.036	.045	.053	—
		1920	0.08	—	0.12	0.17	0.06	0.17	0.02	.052	.064	.077	—
	T/YHC043A (13 SEER)	*800	0.02	.02	0.03	0.04	0.01	0.04	0.00	—	—	—	—
		1280	0.04	.05	0.06	0.08	0.03	0.08	0.01	.023	.029	.034	—
		1600	0.05	.07	0.09	0.12	0.04	0.12	0.01	.036	.045	.053	—
5	T/YSC060A	1600	0.10	—	0.15	0.12	0.04	0.12	0.01	.036	.045	.053	—
		2000	0.15	—	0.22	0.18	0.07	0.18	0.02	.056	.070	.083	—
		2400	0.22	—	0.29	0.26	0.10	0.26	0.04	.081	.100	.120	—
	T/YHC063A (13 SEER)	*1000	0.02	.03	0.04	0.06	0.01	0.06	0.01	—	—	—	—
		1600	0.04	.07	0.07	0.12	0.04	0.12	0.01	.036	.045	.053	—
		2000	0.06	.10	0.10	0.18	0.07	0.18	0.02	.056	.070	.083	—
6	T/YSC072A	2400	0.09	.14	0.14	0.26	0.10	0.26	0.04	.081	.100	.120	—
		1920	0.04	—	0.07	0.10	0.01	0.06	0.02	0.02	0.011	0.021	—
		2400	0.06	—	0.09	0.11	0.02	0.08	0.02	0.02	0.020	0.034	—
	T/YHC072A	2880	0.09	—	0.12	0.13	0.04	0.10	0.04	0.04	0.033	0.052	—

## Performance Data

**Table 128. Static Pressure Drop Through Accessories (Inches Water Column) –3-10 Tons (continued)**

Tons	Unit Model Number	CFM	Standard Filters <sup>(vi)</sup>	Through Reheat Coil (WC)	2" Pleated Filter	Economizer with OA/RA Dampers <sup>(iv)</sup>				Electric Heater Accessory (kW) <sup>(v)</sup>			
						100% OA	100% RA	100% OA	100% RA	5-6	9-15	17-36	54
						Downflow		Horizontal					
7½	T/YSC090,092A	2400	0.06	—	0.09	0.11	0.02	0.08	0.02	0.02	0.020	0.034	—
		3000	0.10	—	0.13	0.14	0.05	0.12	0.05	0.05	0.042	0.063	—
		3600	0.14	—	0.18	0.21	0.07	0.25	0.08	0.08	0.077	0.102	—
	T/YHC092A	*1500	0.02	.07	0.03	0.07	0.01	0.04	0.01	—	—	—	—
		2400	0.04	.10	0.06	0.11	0.02	0.08	0.02	0.02	0.016	0.021	—
		3000	0.06	.14	0.09	0.14	0.05	0.12	0.05	0.05	0.025	0.032	—
8½	T/YSC102A	2720	0.05	—	0.08	0.12	0.03	0.09	0.04	0.04	0.020	0.026	—
		3400	0.08	—	0.11	0.19	0.06	0.18	0.06	0.06	0.032	0.041	—
		4080	0.12	—	0.16	0.30	0.07	0.31	0.09	0.09	0.047	0.059	—
	T/YHC102A	*1700	0.02	.08	0.05	0.07	0.01	0.05	0.02	—	—	—	—
		2720	0.05	.12	0.08	0.12	0.03	0.09	0.04	0.04	0.020	0.026	—
		3400	0.08	.17	0.11	0.19	0.06	0.18	0.06	0.06	0.032	0.041	—
10	T/YSC120A	3200	0.07	—	0.10	0.17	0.05	0.14	0.05	0.05	0.028	0.036	0.042
		4000	0.11	—	0.15	0.26	0.07	0.30	0.08	0.08	0.045	0.056	0.070
		4800	0.16	—	0.20	0.34	0.09	0.35	0.10	0.10	0.065	0.081	0.106
	T/YHC120A	*2000	0.03	0.09	0.06	0.08	0.03	0.07	0.02	—	—	—	—
		3200	0.07	0.15	0.10	0.17	0.05	0.14	0.05	0.05	0.028	0.036	0.042
		4000	0.11	0.22	0.15	0.26	0.07	0.30	0.08	0.08	0.045	0.056	0.070
		4800	0.16	0.31	0.20	0.34	0.09	0.35	0.10	0.10	0.065	0.081	0.106

(i) OA = Outside Air and RA = Return Air.  
(ii) Nominal kW ratings at 240, 480, 600 volts. Heaters only available of T\_C units.  
(iii) Tested with standard filters (3-5 tons 1" filters, 6-10 tons 2" filters). Difference in pressure drop should be considered when utilizing optional 2" pleated filters.  
(iv) OA = Outside Air and RA = Return Air.  
(v) Nominal kW ratings at 240, 480, 600 volts. Heaters only available of T\_C units.  
(vi) Tested with standard filters (3-5 tons 1" filters, 6-10 tons 2" filters). Difference in pressure drop should be considered when utilizing optional 2" pleated filters.

## Performance Data

**Table 129. Gas Fired Heating Capacities**

Tons	Efficiency	Unit Model Number	Heating Input MBH <sup>(i)</sup>	Heating Output MBH <sup>(ii)</sup>	Air Temp. Rise, F
3	Standard	Y*C036A3,A4,AW*L	60.0	48.0	25-56
		Y*C036A3,A4,AW*M	80.0	64.0	35-65
		Y*C036A3,A4,AW*H	120.0	96.0	55-85
4	Standard	Y*C048A3,A4,AW*L	60.0	48.0	15-45
		Y*C048A3,A4,AW*M	80.0	64.0	20-50
		Y*C048A3,A4,AW*H	120.0	96.0	40-70
5	Standard	YSC060A3,A4,AW, AK*L	60.0	48.0	10-40
		YSC060A3,A4,AW, AK*M	80.0	64.0	15-45
		YSC060A3,A4,AW, AK*M	130.0	104.0	35-65
6	Standard & High Efficiency	Y*C072A3,A4,AW, AK*L	80.0	64.8	15-45
		Y*C072A3,A4,AW, AK*M	120.0/84	97.2/68	20-50
		Y*C072A3,A4,AW, AK*H	150.0/105	121.5/85	25-55
7½	Standard & High Efficiency	Y*C090A3,092A3,A4,AW, AK*L	120.0/84	97.2/68	20-50
		Y*C090A3,092A3,A4,AW, AK*M	150.0/105	121.5/85	25-55
		Y*C090A3,092A3,A4,AW, AK*H	200.0/140	162.0/113	35-65
8	Standard & High Efficiency	Y*C102A3,A4,AW, AK*L	120.0/84	97.2/68	15-45
		Y*C102A3,A4,AW, AK*L	150.0/105	121.5/85	20-50
		Y*C102A3,A4,AW, AK*L	200.0/140	162.0/113	35-65
10	Standard & High Efficiency	Y*C120A3,A4,AW, AK*L	150.0/105	121.5/85	20-50
		Y*C120A3,A4,AW, AK*L	200.0/140	162.0/113	25-55
		Y*C120A3,A4,AW, AK*L	250.0/175	202.5/141.8	35-65
<b>13 SEER</b>					
3	High Efficiency	YHC033A3, A4, AW*(L,X)	60	48	25-55
		YHC033A3, A4, AW*(M,Y)	80	64	35-65
		YHC033A3, A4, AW*(H,Z)	120	96	55-85
4	High Efficiency	YHC043A3, A4, AW*(L,X)	60	48	15-45
		YHC043A3, A4, AW*(M,Y)	80	64	20-50
		YHC043A3, A4, AW*(H,Z)	120	96	40-70
5	High Efficiency	YHC063A3, A4, AW, AK*(L,X)	60	48	10-40
		YHC063A3,A4,AW*(M,Y)	80	64	15-45
		YHC063A3, A4, AW, AK*(H,Z)	130	104	35-65

Ratings shown are for elevations up to 2,000 ft. For higher elevations, reduce ratings at a rate of 4% per 1,000 ft. elevation.

<sup>(i)</sup> For two stage heaters (input or output), Second stage is total heating capacity. Second Stage/First Stage.

<sup>(ii)</sup> For two stage heaters (input or output), Second stage is total heating capacity. Second Stage/First Stage.

## Performance Data

**Table 130. Auxiliary Electric Heat Capacity**

Tons	Unit Model Number	Total <sup>(i)</sup>			Stage1		Stage 2	
		kW Input <sup>(ii)</sup>	MBH Output	No. of Stages	kW Input	MBH Output	kW Input	MBH Output
3	T*C036A3, A4, AW	6.00	20.48	1	6.00	20.48	—	—
		12.00	40.97	2	6.00	20.48	6.00	20.48
		17.40	59.40	2	8.70	29.70	8.70	29.69
	THC033A3, A4, AW (13 SEER)	6.00	20.48	1	6.00	20.48	—	—
		12.00	40.97	2	6.00	20.48	6.00	20.48
		17.40	59.40	2	8.70	29.70	8.70	29.69
4	T*C048A3, A4, AW	6.00	20.48	1	6.00	20.48	—	—
		12.00	40.97	2	6.00	20.48	6.00	20.48
		17.40	59.40	2	8.70	29.70	8.70	29.70
	THC043A3, A4, AW (13 SEER)	5.00	17.07	1	5.00	17.07	—	—
		6.00	20.48	1	6.00	20.48	—	—
		12.00	40.97	2	6.00	20.48	6.00	20.48
		17.40	59.40	2	8.70	29.70	8.70	29.70
5	T*C060A3, A4, AW	6.00	20.48	1	6.00	20.48	—	—
		12.00	40.97	2	6.00	20.48	6.00	20.48
		17.40	59.40	2	8.70	29.70	8.70	29.70
		23.00	78.52	2	14.30	48.82	8.70	29.70
	TSC060AK	7.50	25.61	2	3.25	11.10	3.25	11.10
		10.90	37.23	2	5.45	18.61	5.45	18.61
		14.40	49.18	2	7.20	24.59	7.20	24.59
THC063A3, A4, AW (13 SEER)	6.00	20.48	1	6.00	20.48	—	—	
	12.00	40.97	2	6.00	20.48	6.00	20.48	
	17.40	59.40	2	8.70	29.70	8.70	29.70	
	23.00	78.52	2	14.30	48.82	8.70	29.70	
6	T*C072A3, A4, AW	9.00	30.73	1	9.00	30.73	—	—
		18.00	61.45	1	18.00	61.45	—	—
		27.00	92.18	2	18.00	61.45	9.00	30.73
		36.00	122.90	2	18.00	61.45	18.00	61.45
	TSC072AK	11.30	38.60	1	11.30	38.60	—	—
		16.90	57.72	2	11.30	38.60	5.60	19.13
		22.60	77.18	2	11.30	38.60	11.30	38.60
7½	T*SC090A3, A4, AW	9.00	30.73	1	9.00	30.73	—	—
		18.00	61.45	1	18.00	61.45	—	—
		27.00	92.18	2	18.00	61.45	9.00	30.73
		36.00	122.90	2	18.00	61.45	18.00	61.45
	TSC090AK	11.30	38.60	1	11.30	38.60	—	—
		16.90	57.72	2	11.30	38.60	5.60	19.13
		22.60	77.18	2	11.30	38.60	11.30	38.60
T*C092A3, A4, AW	9.00	30.73	1	9.00	30.73	—	—	
	18.00	61.45	1	18.00	61.45	—	—	
	27.00	92.18	2	18.00	61.45	9.00	30.73	
	36.00	122.90	2	18.00	61.45	18.00	61.45	
8½	T*C102A3, A4, AW	9.00	30.73	1	9.00	30.73	—	—
		18.00	61.45	1	18.00	61.45	—	—
		27.00	92.18	2	18.00	61.45	9.00	30.73
		36.00	122.90	2	18.00	61.45	18.00	61.45
	TSC102AK	16.90	57.72	2	11.30	38.60	5.60	19.13
		22.60	77.18	2	11.30	38.60	11.30	38.60
		18.00	61.45	1	18.00	61.45	—	—
10	T*C120A3, A4, AW	27.00	92.18	2	18.00	61.45	9.00	30.73
		36.00	122.90	2	18.00	61.45	18.00	61.45
		54.00	184.36	2	36.00	122.90	18.00	61.45

## Performance Data

**Table 130. Auxiliary Electric Heat Capacity (continued)**

Tons	Unit Model Number	Total <sup>(iii)</sup>			Stage1		Stage 2	
		kW Input <sup>(iv)</sup>	MBH Output	No. of Stages	kW Input	MBH Output	kW Input	MBH Output
10	TSC120AK	16.90	57.72	2	11.30	38.60	11.30	38.60
		22.60	77.18	2	11.30	38.60	11.30	38.60
		33.80	115.43	2	22.50	76.84	11.30	38.60

- (i) Heaters are rated at 240v,380v,480v and 600v. For other than rated voltage, CAP= (voltage/rated voltage)<sup>2</sup> x rated cap.  
(ii) All input/output does not include indoor fan power or heat.  
\*Indicates both standard and high efficiency airflow.  
(iii) Heaters are rated at 240v,380v,480v and 600v. For other than rated voltage, CAP= (voltage/rated voltage)<sup>2</sup> x rated cap.  
(iv) All input/output does not include indoor fan power or heat.  
\*Indicates both standard and high efficiency airflow.

**Table 131. Electric Heater Voltage Correction Factors (Applicable to Auxiliary Heat Capacity)**

Nominal Voltage	Distribution Voltage	Capacity Multiplier
240	208	0.751
	230	0.918
	240	1.000
380	380	1.000
	440	0.840
480	460	0.918
	480	1.000
	540	0.810
600	575	0.918
	600	1.000

**Table 132. 3-5 Tons Air Temperature Rise Across Electric Heaters (Degrees F)**

kW	Stages	3 Tons	4 Tons	5 Tons	
		1200 CFM	1600 CFM <sup>(i)</sup>	2000 CFM	
		Three Phase	Three Phase	Three Phase	
		T*C036A3,A4,AW	T*C048A3,A4,AW	T*C060A3,A4,AW	TSC060AK
5.00	1	—	—	—	—
6.00	1	15.8	11.9	9.5	—
7.50	2	—	—	—	11.9
10.00	2	—	—	—	—
10.90	2	—	—	—	17.2
12.00	2	31.6	23.7	19.0	—
13.80	2	—	—	—	—
14.40	2	—	—	—	22.8
17.40	2	45.8	34.4	27.5	—
17.60	2	—	—	—	—
23.00	2	—	—	36.4	—

For minimum design airflow, see airflow performance table for each unit.  
To calculate temp rise at different airflow, use the following formula:  
Temp. rise across Electric Heater = kWx3414/1.08xCFM.  
\*Indicates both standard and high efficiency airflow.

- (i) Minimum allowable airflow with a 17.4 or 17.6 kW heater is 1440 cfm.

## Performance Data

---

**Table 133. Air Temperature Rise Across Electric Heaters (Degrees F) - 13 SEER**

kW	Stages	3 Tons	4 Tons	5 Tons
		1200 CFM	1600 CFM <sup>(1)</sup>	2000 CFM
		Three Phase	Three Phase	Three Phase
		THC033A3,A4,AW	THC043A3,A4,AW	THC063A3,A4,AW
5.00	1	15.8	11.9	—
6.00	1	—	—	9.5
7.50	2	—	—	—
10.00	2	—	—	—
10.90	2	—	—	—
12.00	2	31.6	23.7	19.0
13.80	2	—	—	—
14.40	2	—	—	—
17.40	2	45.8	34.4	27.5
17.60	2	—	—	—
23.00	2	—	—	36.4

For minimum design airflow, see airflow performance table for each unit.  
 To calculate temp rise at different airflow, use the following formula:  
 Temp. rise across Electric Heater = kWx3414/1.08xCFM.

<sup>(1)</sup> Minimum allowable airflow with a 17.4 or 17.6 kW heater is 1440 cfm.

**Table 134. 6-10 Tons Air Temperature Rise Across Electric Heaters (Degrees F)**

kW	Stages	6 Tons	7½ Tons		8½ Tons	10 Tons			
		2000 CFM	3000 CFM		3400 CFM <sup>(1)</sup>	4000 CFM			
		T*CO90A3, A4, AW							
		T*CO72A3, A4, AW	TSC072AK	T*CO92A3, A4, AW	TSC090AK	T*CO102A3, A4, AW	TSC102AK	T*CO120A3,A4,AW	TSC120AK
9.00	1	14.2	—	9.5	—	8.4	—	—	—
11.30	1	—	14.9	—	11.9	—	—	—	—
16.90	2	—	22.3	—	17.8	—	15.7	—	13.4
18.00	1	28.5	—	19.0	—	16.7	—	14.2	—
22.60	2	—	29.8	—	23.8	—	21.0	—	17.9
27.00	2	42.7	—	28.5	—	25.1	—	21.3	—
33.80	2	—	—	—	—	—	—	—	26.7
36.00	2	56.9	—	37.9	—	33.5	—	28.5	—
54.00	2	—	—	—	—	—	—	42.7	—

For minimum design airflow, see airflow performance table for each unit. To calculate temp rise at different airflow, use the following formula:  
 Temp. rise across Electric Heater = kWx3414/1.08xCFM.

\*Indicates both standard and high efficiency airflow.

<sup>(1)</sup> Minimum allowable airflow with a 17.4 or 17.6 kW heater is 1440 cfm.

## Performance Data

**Table 135. Hot Gas Reheat Temperature Rise<sup>(i),(ii), (iii)</sup>**

Tons	Unit Model		Leaving Evaporator Dry Bulb [F]						
	Number	SCFM	35	40	45	50	55	60	65
3	T/YHC	600	20.3	20.0	19.6	19.2	18.8	18.4	18.0
		720	19.4	19.1	18.7	18.3	17.9	17.6	17.2
		840	18.5	18.2	17.9	17.5	17.1	16.7	16.3
		960	17.6	17.3	17.0	16.6	16.2	15.8	15.5
		1080	16.7	16.4	16.1	15.7	15.4	15.0	14.6
		1200	15.8	15.5	15.2	14.9	14.5	14.1	13.8
		1320	14.9	14.6	14.3	14.0	13.6	13.3	12.9
		1440	14.0	13.8	13.5	13.1	12.8	12.4	12.0
4	T/YHC	800	22.0	21.8	21.5	21.2	20.9	20.6	20.3
		960	21.0	20.7	20.5	20.2	19.9	19.6	19.3
		1120	20.0	19.7	19.5	19.2	18.9	18.6	18.2
		1280	19.0	18.7	18.4	18.1	17.9	17.5	17.2
		1440	17.9	17.7	17.4	17.1	16.9	16.5	16.2
		1600	16.9	16.6	16.4	16.1	15.8	15.5	15.2
		1760	15.9	15.6	15.4	15.1	14.8	14.5	14.2
		1920	14.8	14.6	14.4	14.1	13.8	13.5	13.2
5	T/YHC	1000	23.7	23.6	23.4	23.2	23.0	22.8	22.5
		1200	22.6	22.4	22.2	22.0	21.8	21.6	21.3
		1400	21.4	21.2	21.0	20.9	20.7	20.4	20.2
		1600	20.3	20.1	19.9	19.7	19.5	19.3	19.0
		1800	19.1	18.9	18.7	18.5	18.4	18.1	17.8
		2000	17.9	17.8	17.6	17.4	17.2	16.9	16.6
		2200	16.8	16.6	16.4	16.2	16.0	15.7	15.4
		2400	15.6	15.4	15.2	15.1	14.9	14.6	14.3
7½	T/YHC	*1500	22.0	22.9	23.8	24.7	25.6	26.5	27.5
		*1800	20.2	21.0	21.9	22.7	23.5	24.4	25.3
		*2100	18.5	19.2	19.9	20.7	21.4	22.3	23.1
		2400	16.7	17.3	18.0	18.7	19.3	20.1	20.9
		2700	14.9	15.5	16.1	16.7	17.3	18.0	18.7
		3000	13.1	13.7	14.2	14.7	15.2	15.9	16.5
		3300	11.4	11.8	12.3	12.7	13.1	13.7	14.3
		3600	9.6	10.0	10.3	10.7	11.1	11.6	12.2
8½	T/YHC	*1700	22.6	23.7	24.9	26.1	27.2	28.3	29.4
		*2040	20.6	21.6	22.7	23.7	24.7	25.7	26.6
		*2380	18.6	19.5	20.4	21.3	22.2	23.0	23.8
		2720	16.6	17.4	18.2	18.9	19.7	20.3	21.0
		3060	14.7	15.3	15.9	16.6	17.2	17.7	18.1
		3400	12.7	13.2	13.7	14.2	14.7	15.0	15.3
		3740	10.7	11.1	11.4	11.8	12.2	12.3	12.5
		4080	8.7	9.0	9.2	9.4	9.6	9.7	9.7
10	T/YHC	*2000	26.0	26.5	26.9	27.4	27.9	28.3	28.6
		*2400	23.5	24.1	24.7	25.3	25.9	26.4	26.9
		*2800	21.1	21.8	22.5	23.3	24.0	24.6	25.1
		3200	18.7	19.5	20.3	21.2	22.0	22.7	23.4
		3600	16.2	17.2	18.1	19.1	20.1	20.8	21.6
		4000	13.8	14.9	15.9	17.0	18.1	19.0	19.8
		4400	11.3	12.5	13.7	14.9	16.1	17.1	18.1
		4800	8.9	10.2	11.5	12.9	14.2	15.3	16.3

<sup>(i)</sup> Temperature rise does not account for indoor fan heat.

<sup>(ii)</sup> 70 deg OD Ambient Temperature.

<sup>(iii)</sup> For units with the Dehumidification (Hot Gas Reheat) option.

\* Unit applications below 320 CFM/Ton are only applicable to T\_C models only (No Gas Heat).

The following restrictions: Electric heaters restricted on applications below 320 CFM/Ton.

Dehumidification (Hot Gas Reheat) or TXV with Froststat and Crankcase Heaters are required on applications below 320 CFM/Ton.



# Controls

## ReliaTel™ Controlled Units

Zone Sensors are the building occupant's comfort control devices for Convertible units with the Micro control:

### Manual Changeover

Heat, Cool or Off System Switch. Fan Auto or Off Switch. One temperature setpoint lever.

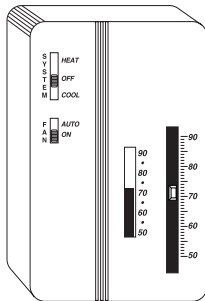

### Manual/ Automatic Changeover

Auto, Heat, Cool or Off System Switch. Fan Auto or Off Switch. Two temperature setpoint levers. Optional Status Indication LED lights, System On, Heat, Cool, or Service.

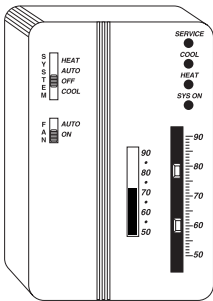

### Remote Sensor

Sensor(s) available for all zone sensors to provide remote sensing capabilities.

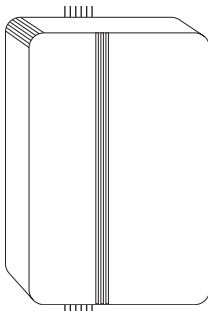

## Dual Thermistor Remote Zone Sensor

This sensor will allow the customer to reduce the total number of remote sensors to obtain space temperature averaging. This sensor should be utilized with ReliaTel controls.

## Digital Display Zone Sensor

The Digital LCD (Liquid Crystal Display) zone sensor has the look and functionality of standard zone sensors. This sensor includes a digital display of set point adjustment and space temperature in F (Fahrenheit) or C (Celsius). Includes FAN and SYSTEM buttons (supports the service functions of the standard sensor). E-squared memory stores last programmed set points. Requires 24 VAC (Volts AC). This sensor should be utilized with ReliaTel™ controls.

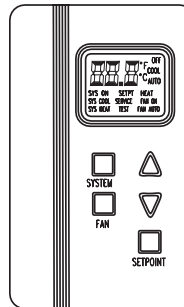

## Programmable Night Setback

Auto or manual changeover with seven-day programming. Keyboard selection of Heat, Cool, Fan, Auto, or On. All programmable sensors have System On, Heat, Cool, Service LED/indicators as standard. Night Setback Sensors have one (1) Occupied, one (1) Un-occupied, and two (2) Override programs per day.

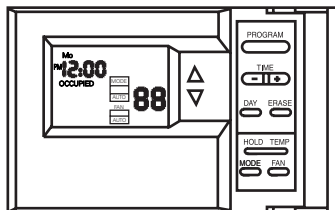

## Humidity Sensor

Field installed, wall-mounted or duct-mounted humidity sensor is used to control activation of the hot gas reheat dehumidification option. The humidity sensor can be set for humidity levels between 40% and 60% relative humidity by adjusting the ReliaTel Options Module.

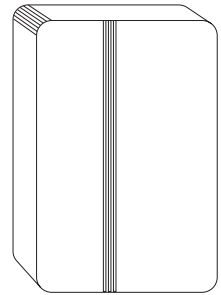

## CO<sub>2</sub> Sensing

The CO<sub>2</sub> sensor shall have the ability to monitor space occupancy levels within the building by measuring the parts per million of CO<sub>2</sub> (Carbon Dioxide) in the air. As the CO<sub>2</sub> levels increase, the outside air damper modulates to meet the CO<sub>2</sub> space ventilation requirements. The CO<sub>2</sub> accessory shall be available as field installed.

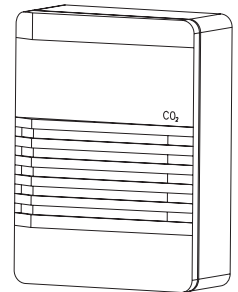

## Controls

### Digital Display Programmable Thermostat (2H/2C)

Two Heat/Two Cool digital display thermostat. 7-day programmable stat with night setback shall be available.

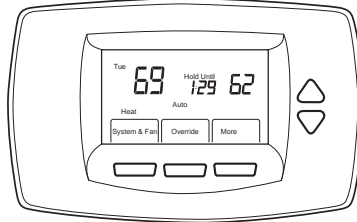

### Touchscreen Programmable Thermostat (2H/2C)

Two Heat/Two Cool programmable thermostat with touch screen digital display. Menu-driven programming. Effortless set-up. Program each day separately with no need to copy multiple days. All programming can be done on one screen. Easy to read and use. Large, clear backlit digital display.

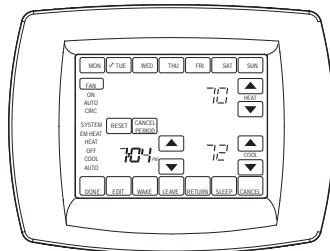

### Digital Display Programmable Thermostat with Built-In Relative Humidity Sensing (3H/2C)

Three Heat/Two Cool digital display thermostat with built-in humidity control and display. This thermostat combines both humidity and dry bulb into one. Fully programmable with night setback.

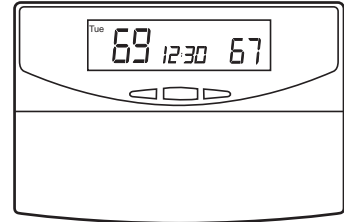

### Digital Display Thermostat (3H/2C)

Three Heat, Two Cool digital display thermostat. Easy access battery replacement. Flip-out door for easy battery replacement without removing or disassembling the thermostat.

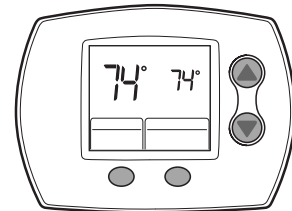

### RA Remote Sensor

Return Air Remote Sensor which can be mounted in the return air duct to report return air temperature.

### Room Remote Sensor

Space Remote Sensor which can be mounted on the wall to report/control from a remote location in the space.

## Electrical Data

**Table 136. Unit Wiring with Gas Heat or Cooling (No Electric Heat)**

Tons	Unit Model Number	Unit Operating Voltage Range	Standard Indoor Fan Motor		Oversize Indoor Fan Motor		Optional Belt Drive Indoor Fan Motor <sup>(i)</sup>	
			Minimum Circuit Ampacity	Maximum Fuse Size or Maximum Circuit Breaker <sup>(ii)</sup>	Minimum Circuit Ampacity	Maximum Fuse Size or Maximum Circuit Breaker	Minimum Circuit Ampacity	Maximum Fuse Size or Maximum Circuit Breaker
3	T/YSC036A3	187-253	17.9	25	20.3	30	20.6	30
	T/YSC036A4	414-506	9.2	15	10.4	15	10.6	15
	T/YSC036AW	517-633	7.7	15	8.3	15	8.3	15
4	T/YSC048A3	187-253	23.9	35	26.0	40	25.3	35
	T/YSC048A4	414-506	12.8	20	14.4	20	13.6	20
	T/YSC048AW	517-633	9.8	15	10.6	15	10.0	15
5	T/YSC060A3	187-253	31.5	50	33.2	50	30.3	45
	T/YSC060A4	414-506	16.0	25	16.3	25	15.6	25
	T/YSC060AW	517-633	12.2	15	12.8	20	11.8	15
	T/YSC060AK	342-418	19.6	30	—	—	—	—
6	T/YSC072A3	187-253	32.7	50	34.0	50	—	—
	T/YSC072A4	414-506	17.6	25	18.2	25	—	—
	T/YSC072AW	517-633	12.8	20	13.6	20	—	—
	T/YSC072AK	342-418	23.2	35	—	—	—	—
7½	T/YSC090A3	187-253	42.7	60	45.8	60	—	—
	T/YSC090A4	414-506	22.6	35	24.1	35	—	—
	T/YSC090AW	517-633	17.6	25	18.8	25	—	—
	T/YSC090AK	342-418	28.4	40	29.9	45	—	—
	T/YSC092A3	187-253	38.9	50	42.0	50	—	—
	T/YSC092A4	414-506	20.5	25	22.0	25	—	—
8½	T/YSC102A3	187-253	45.1	60	48.2	60	—	—
	T/YSC102A4	414-506	24.0	30	25.5	35	—	—
	T/YSC102AW	517-633	19.5	25	20.7	25	—	—
	T/YSC102AK	342-418	32.6	40	35.6	45	—	—
10	T/YSC120A3	187-253	52.6	60	56.6	70	—	—
	T/YSC120A4	414-506	26.9	35	28.9	35	—	—
	T/YSC120AW	517-633	21.8	25	23.5	30	—	—
	T/YSC120AK	342-418	32.6	40	35.6	45	—	—

<sup>(i)</sup> For standard and oversized motors, HACR breaker per NEC.

<sup>(ii)</sup> Optional Belt Drive motor applies to 3-5 ton models only. The Standard Motor for 3-5 ton models is Direct Drive. The Standard Motor for 6-10 ton models is Belt Drive.

**Electrical Data**

*(Standard Efficiency)*

**Table 137. Unit Wiring with Electric Heat (Single Point Connection) — Standard and Oversized Motor<sup>(i)</sup>**

Tons	Unit Model Number	Heater Model Number	Heater kW Rating <sup>(ii)</sup>	Control Stages	Standard Indoor Motor		Oversize Indoor Motor	
					MCA	Max Fuse Size or Max Circuit Breaker <sup>(iii)</sup>	MCA	Max Fuse Size or Max Circuit Breaker
208/230 Volts Three Phase								
3	TSC036A3	BAYHTRR306A	4.5/6.0	1	18.5/20.9	25/25	21.5/23.9	30/30
		BAYHTRR312A	9.0/12.0	2	34.1/39.0	35/40	37.1/42.0	40/45
		BAYHTRR318A	13.1/17.4	2	48.3/55.3	50/60	51.3/58.3	60/60
4	TSC048A3	BAYHTRR306A	4.5/6.0	1	23.9/23.9	35/35	26.0/26.0	40/40
		BAYHTRR312A	9.0/12.0	2	35.8/40.6	40/45	38.4/43.3	40/45
		BAYHTRR318A	13.1/17.4	2	49.9/56.9	50/60	52.5/59.5	60/60
5	TSC060A3	BAYHTRR306A	4.5/6.0	1	31.5/31.5	50/50	33.2/33.2	50/50
		BAYHTRR312A	9.0/12.0	2	39.0/43.9	50/50	41.1/46.0	50/50
		BAYHTRR318A	13.1/17.4	2	53.1/60.1	60/70	55.3/62.3	60/70
		BAYHTRR323A	17.3/23.0	2	67.8/76.9	70/80	69.9/79.0	70/80
6	TSC072A3	BAYHTRS309A	6.8/9.0	1	32.7/33.4	50/50	34.0/35.0	50/50
		BAYHTRS318A	13.5/18.0	1	53.1/60.4	60/70	54.8/62.0	60/70
		BAYHTRS327A	20.3/27.0	2	76.6/87.5	80/90	78.3/89.1	80/90
		BAYHTRS336A	27.0/36.0	2	100.1/114.5	110/125	101.8/116.1	110/125
7½	TSC090A3	BAYHTRS309A	6.8/9.0	1	42.7/42.7	60/60	45.8/45.8	60/60
		BAYHTRS318A	13.5/18.0	1	54.8/62.0	60/70	58.6/65.9	60/70
		BAYHTRS327A	20.3/27.0	2	78.3/89.1	80/90	82.1/93.0	90/100
		BAYHTRS336A	27.0/36.0	2	101.8/116.1	110/125	105.6/120.0	110/125
	TSC092A3	BAYHTRS309A	6.8/9.0	1	38.9/38.9	50/50	42.0/42.0	50/50
		BAYHTRS318A	13.5/18.0	1	54.8/62.0	60/70	58.6/65.9	60/70
		BAYHTRS327A	20.3/27.0	2	78.3/89.1	80/90	82.1/93.0	90/100
		BAYHTRS336A	27.0/36.0	2	101.8/116.1	110/125	105.6/120.0	110/125
8½	TSC102A3	BAYHTRT309A	6.8/9.0	1	45.1/45.1	60/60	48.2/48.2	60/60
		BAYHTRT318A	13.5/18.0	1	54.8/62.0	60/70	58.6/65.9	60/70
		BAYHTRT327A	20.3/27.0	2	78.3/89.1	80/90	82.1/93.0	90/100
		BAYHTRT336A	27.0/36.0	2	101.8/116.1	110/125	105.6/120.0	110/125
10	TSC120A3	BAYHTRT318A	13.5/18.0	1	58.6/65.9	60/70	63.6/70.9	70/80
		BAYHTRT327A	20.3/27.0	2	82.1/93.0	90/100	87.1/98.0	90/100
		BAYHTRT336A	27.0/36.0	2	105.8/120.0	110/125	110.6/125.0	125/125
		BAYHTRT354A	40.6/54.0	2	152.5/141.7	175/150	157.5/146.7	175/150
380 Volts Three Phase								
5	TSC060AK	BAYHTRR412A	7.5	2	19.6	30	—	—
		BAYHTRR418A	10.9	2	26.1	30	—	—
		BAYHTRR423A	14.4	2	32.8	35	—	—
6	TSC072AK	BAYHTRS418A	11.3	1	27.6	35	—	—
		BAYHTRS427A	16.9	2	38.3	40	—	—
		BAYHTRS436A	22.6	2	49.0	50	—	—
7½	TSC090AK	BAYHTRS418A	11.3	1	28.4	40	29.9	45
		BAYHTRS427A	16.9	2	38.3	40	40.1	45
		BAYHTRS436A	22.6	2	49.0	50	50.9	60
8½	TSC102AK	BAYHTRT427A	16.9	2	38.8	40	40.1	45
		BAYHTRT436A	22.6	2	49.0	50	50.9	60
10	TSC120AK	BAYHTRT427A	16.9	2	40.1	45	43.6	45
		BAYHTRT436A	22.6	2	50.9	60	54.4	60
		BAYHTRT454A	33.8	2	72.3	80	75.8	80
460 Volts Three Phase								
3	TSC036A4	BAYHTRR406A	6.0	1	10.4	15	11.9	15
		BAYHTRR412A	12.0	2	19.4	20	20.9	25
		BAYHTRR418A	17.4	2	27.5	30	29.0	30
4	TSC048A4	BAYHTRR406A	6.0	1	12.8	20	14.4	20
		BAYHTRR412A	12.0	2	20.1	25	22.1	25
		BAYHTRR418A	17.4	2	28.3	30	30.3	35

**Electrical Data**

*(Standard Efficiency)*

**Table 137. (continued) Unit Wiring with Electric Heat (Single Point Connection) — Standard and Oversized Motor<sup>(i)</sup>**

Tons	Unit Model Number	Heater Model Number	Heater kW Rating	Control Stages	Standard Indoor Motor		Oversize Indoor Motor	
					MCA	Max Fuse Size or Max Circuit Breaker	MCA	Max Fuse Size or Max Circuit Breaker
5	TSC060A4	BAYHTRR406A	6.0	1	16.0	25	16.3	25
		BAYHTRR412A	12.0	2	21.6	25	22.0	25
		BAYHTRR418A	17.4	2	29.8	30	30.1	35
		BAYHTRR423A	23.0	2	38.3	40	38.6	40
6	TSC072A4	BAYHTRS409A	9.0	1	17.6	25	18.2	25
		BAYHTRS418A	18.0	1	30.3	35	31.0	35
		BAYHTRS427A	27.0	2	43.8	45	44.5	45
		BAYHTRS436A	36.0	2	57.3	60	58.0	60
7½	TSC090A4	BAYHTRS409A	9.0	1	22.6	35	24.1	35
		BAYHTRS418A	18.0	1	31.0	35	32.9	35
		BAYHTRS427A	27.0	2	44.5	45	46.4	50
		BAYHTRS436A	36.0	2	58.0	60	59.9	60
	TSC092A4	BAYHTRS409A	9.0	1	20.5	25	22.0	25
		BAYHTRS418A	18.0	1	31.0	35	32.9	35
		BAYHTRS427A	27.0	2	44.5	45	46.4	50
		BAYHTRS436A	36.0	2	58.0	60	59.9	60
8½	TSC102A4	BAYHTRT409A	9.0	1	24.0	30	25.5	35
		BAYHTRT418A	18.0	1	31.0	35	32.9	35
		BAYHTRT427A	27.0	2	44.5	45	46.4	50
		BAYHTRT436A	36.0	2	58.0	60	59.9	60
10	TSC120A4	BAYHTRT418A	18.0	1	32.9	35	35.4	40
		BAYHTRT427A	27.0	2	46.4	50	48.9	50
		BAYHTRT436A	36.0	2	59.9	60	62.4	70
		BAYHTRT454A	54.0	2	70.8	80	73.3	80
575 Volts Three Phase								
3	TSC036AW	BAYHTRRW06A	6.0	1	8.6	15	9.3	15
		BAYHTRRW12A	12.0	2	15.8	20	16.6	20
		BAYHTRRW18A	17.4	2	22.3	25	23.1	25
4	TSC048AW	BAYHTRRW06A	6.0	1	9.8	15	10.6	15
		BAYHTRRW12A	12.0	2	16.3	20	17.3	20
		BAYHTRRW18A	17.4	2	22.8	25	23.8	25
5	TSC060AW	BAYHTRRW06A	6.0	1	12.2	15	12.8	20
		BAYHTRRW12A	12.0	2	17.1	20	17.8	20
		BAYHTRRW18A	17.4	2	23.6	25	24.3	25
		BAYHTRRW23A	23.0	2	30.3	35	31.0	35
6	TSC072AW	BAYHTRSW09A	9.0	1	13.0	20	14.0	20
		BAYHTRSW18A	18.0	1	23.8	25	24.8	25
		BAYHTRSW27A	27.0	2	34.6	35	35.6	40
		BAYHTRSW36A	36.0	2	45.4	50	46.4	50
7½	TSC090AW	BAYHTRSW09A	9.0	1	17.6	25	18.8	25
		BAYHTRSW18A	18.0	1	24.8	25	26.3	30
		BAYHTRSW27A	27.0	2	35.6	40	37.1	40
		BAYHTRSW36A	36.0	2	46.4	50	47.9	50
	TSC092AW	BAYHTRSW09A	9.0	1	15.5	20	16.7	20
		BAYHTRSW18A	18.0	1	24.8	25	26.3	30
		BAYHTRSW27A	27.0	2	35.6	40	37.1	40
		BAYHTRSW36A	36.0	2	46.4	50	47.9	50
8½	TSC102AW	BAYHTRTW18A	18.0	1	24.8	25	26.3	30
		BAYHTRTW27A	27.0	2	35.6	40	37.1	40
		BAYHTRTW36A	36.0	2	46.4	50	47.9	50

## Electrical Data

*(Standard Efficiency)*

**Table 137. (continued) Unit Wiring with Electric Heat (Single Point Connection) — Standard and Oversized Motor<sup>(i)</sup>**

Tons	Unit Model Number	Heater Model Number	Heater kW Rating	Control Stages	Standard Indoor Motor		Oversize Indoor Motor	
					MCA	Max Fuse Size or Max Circuit Breaker	MCA	Max Fuse Size or Max Circuit Breaker
10	TSC120AW	BAYHTRTW18A	18.0	1	26.3	30	28.4	30
		BAYHTRTW27A	27.0	2	37.1	40	39.3	40
		BAYHTRTW36A	36.0	2	47.9	50	50.0	50
		BAYHTRTW54A	54.0	2	56.6	60	58.8	70

<sup>(i)</sup> Standard and Oversized Motor for 3-5 ton is Direct Drive. 6-10 ton is Belt Drive.

<sup>(ii)</sup> For standard and oversized motors, HACR breaker per NEC.

<sup>(iii)</sup> Heater kW ratings are at 208/240 for 208/230V unit.

**Table 138. Unit Wiring with Electric Heat (Single Point Connection) — Optional Belt Drive**

Tons	Unit Model Number	Heater Model Number	Heater kW Rating <sup>(i)</sup>	Control Stages	MCA	Optional Belt Drive Indoor Motor
						Max Fuse Size or Max Circuit Breaker <sup>(ii)</sup>
208/230 Volts Three Phase						
3	TSC036A3	BAYHTRR306A	4.5/6.0	1	21.9/24.3	30/30
		BAYHTRR312A	9.0/12.0	2	37.5/42.4	40/45
		BAYHTRR318A	13.1/17.4	2	51.6/58.6	60/60
4	TSC048A3	BAYHTRR306A	4.5/6.0	1	25.3/25.3	35/35
		BAYHTRR312A	9.0/12.0	2	37.5/42.4	40/45
		BAYHTRR318A	13.1/17.4	2	51.6/58.6	60/60
5	TSC060A3	BAYHTRR306A	4.5/6.0	1	30.3/30.3	45/45
		BAYHTRR312A	9.0/12.0	2	37.5/42.4	45/45
		BAYHTRR318A	13.1/17.4	2	51.6/58.6	60/60
		BAYHTRR323A	17.3/23.0	2	66.3/75.4	70/80
460 Volts Three Phase						
3	TSC036A4	BAYHTRR406A	6.0	1	12.1	15
		BAYHTRR412A	12.0	2	21.1	25
		BAYHTRR418A	17.4	2	29.3	30
4	TSC048A4	BAYHTRR406A	6.0	1	13.6	20
		BAYHTRR412A	12.0	2	21.1	25
		BAYHTRR418A	17.4	2	29.3	30
5	TSC060A4	BAYHTRR406A	6.0	1	15.6	25
		BAYHTRR412A	12.0	2	21.1	25
		BAYHTRR418A	17.4	2	29.3	30
		BAYHTRR423A	23.0	2	37.8	40
575 Volts Three Phase						
3	TSC036AW	BAYHTRRW06A	6.0	1	9.3	15
		BAYHTRRW12A	12.0	2	16.6	20
		BAYHTRRW18A	17.4	2	23.1	25
4	TSC048AW	BAYHTRRW06A	6.0	1	10.0	15
		BAYHTRRW12A	12.0	2	16.6	20
		BAYHTRRW18A	17.4	2	23.1	25
5	TSC060AW	BAYHTRRW06A	6.0	1	11.8	15
		BAYHTRRW12A	12.0	2	16.6	20
		BAYHTRRW18A	17.4	2	23.1	25
		BAYHTRRW23A	23.0	2	29.8	30

<sup>(i)</sup> Heater kW ratings are at 208/240 for 208/230V unit.

<sup>(ii)</sup> HACR type circuit breaker per NEC.

## Electrical Data

*(Standard Efficiency)*

**Table 139. Electrical Characteristics — Compressor Motor and Condenser Motor — 60 Cycle**

Tons	Unit Model Number	No.	Compressor Motors						Condenser Fan Motors				
			Volts	Phase	HP <sup>(ii)</sup>	RPM	Amps <sup>(i)</sup>		No.	Phase	HP	Amps	
							RLA	LRA				FLA	LRA
3	T/YSC036A3	1	208-230	3	3.1	3450	11.3	74.0	1	1	.20	1.5	2.5
	T/YSC036A4	1	460	3	3.1	3450	6.0	37.6	1	1	.20	0.6	1.3
	T/YSC036AW	1	575	3	3.1	3450	4.9	30.4	1	1	.20	0.5	1.2
4	T/YSC048A3	1	208-230	3	3.9	3450	14.6	91.0	1	1	.33	2.0	6.6
	T/YSC048A4	1	460	3	3.9	3450	7.9	46.0	1	1	.33	1.2	2.5
	T/YSC048AW	1	575	3	3.9	3450	6.1	37.0	1	1	.33	0.7	1.5
5	T/YSC060A3	1	208-230	3	5.1	3450	18.6	128.0	1	1	.33	2.0	6.6
	T/YSC060A4	1	460	3	5.1	3450	9.5	63.0	1	1	.33	1.2	2.5
	T/YSC060AW	1	575	3	5.1	3450	7.5	49.0	1	1	.33	0.7	1.5
	T/YSC060AK	1	380	3	5.1	3450	11.4	64	1	1	.40	1.1	4.3
6	T/YSC072A3	1	208-230	3	6	3450	19.0	156	1	1	.70	3.85	9.30
	T/YSC072A4	1	460	3	6	3450	10.1	75	1	1	.70	2.50	5.80
	T/YSC072AW	1	575	3	6	3450	7.7	54	1	1	.70	1.54	3.60
	T/YSC072AK	1	380	3	6	3450	12.2	70	1	1	.75	2.5	7.7
7½	T/YSC090A3	1	208-230	3	7.5	3450	26.0	181.5	1	1	.70	3.85	9.30
	T/YSC090A4	1	460	3	7.5	3450	13.6	95.0	1	1	.70	2.50	5.80
	T/YSC090AW	1	575	3	7.5	3450	10.9	69.0	1	1	.70	1.54	3.60
	T/YSC090AK	1	380	3	7.5	3450	16.4	106.3	1	1	.75	2.5	7.7
	T/YSC092A3	2	208-230	3	4/2.8	3450	14.7/10.3	91/77	1	1	.70	3.85	9.30
	T/YSC092A4	2	460	3	4/2.8	3450	7.6/5.4	50/39	1	1	.70	2.50	5.80
	T/YSC092AW	2	575	3	4/2.8	3450	5.8/4.2	37/31	1	1	.70	1.54	3.60
8½	T/YSC102A3	2	208-230	3	5.1/2.8	3450	18.6/10.3	128/77	1	1	.75	4.0	9.4
	T/YSC102A4	2	460	3	5.1/2.8	3450	10.0/5.4	63/39	1	1	.75	2.8	6.8
	T/YSC102AW	2	575	3	5.1/2.8	3450	8.2/4.2	49/31	1	1	.75	2.4	6.2
	T/YSC102AK	1	380	3	5.1/2.8	3450	12.1/6.6	64/39	1	1	.75	2.5	7.7
10	T/YSC120A3	2	208-230	3	5.1/3.9	3450	18.6/14.7	128/91	1	1	.75	4.0	9.4
	T/YSC120A4	2	460	3	5.1/3.9	3450	9.5/7.4	63/46	1	1	.75	2.8	6.8
	T/YSC120AW	2	575	3	5.1/3.9	3450	7.8/5.8	49/37	1	1	.75	2.4	6.2
	T/YSC120AK	1	380	3	5.1/3.9	3450	11.5/9.0	64/54	1	1	.75	2.5	7.7

<sup>(i)</sup> Amp draw for each motor; multiply value by number of motors to determine total amps.

<sup>(ii)</sup> HP for each compressor.

## Electrical Data

*(Standard Efficiency)*

**Table 140. Electrical Characteristics — Evaporator Fan Motor — 60 Cycle — Standard and Oversized Motor<sup>(1)</sup>**

Tons	Unit Model Number	No.	Standard Evaporator Fan Motor					Oversized Evaporator Fan Motor					
			Volts	Phase	HP	Amps		Volts	Phase	HP	Amps		
						FLA	LRA				FLA	LRA	
3	T/YSC036A3	1	208-230	1	.33	2.30	3.90	1	208-230	1	.50	4.70	9.80
	T/YSC036A4	1	460	1	.33	1.10	2.00	1	460	1	.50	2.30	5.20
	T/Y*036AW	1	575	1	.33	1.10	1.80	1	460	1	.50	1.70	3.60
4	T/YSC048A3	1	208-230	1	.60	3.60	6.60	1	208-230	1	.80	5.70	13.60
	T/YSC048A4	1	460	1	.60	1.70	2.80	1	460	1	.80	3.30	7.20
	T/YSC048AW	1	575	1	.60	1.50	2.40	1	575	1	.80	2.30	5.80
5	T/YSC060A3	1	208-230	1	.90	6.20	14.0	1	208-230	1	1.00	7.90	16.40
	T/YSC060A4	1	460	1	.90	2.90	6.60	1	460	1	1.00	3.2	8.20
	T/YSC060AW	1	575	1	.90	2.10	4.90	1	575	1	1.00	2.4	5.00
	T/YSC060AK	1	380	1	1.00	4.3	8.3	—	—	—	—	—	—
6	T/YSC072A3	1	208-230	3	1.00	5.00	32.20	1	208-230	3	2.00	6.30	48.00
	T/YSC072A4	1	460	3	1.00	2.50	16.10	1	460	3	2.00	3.10	24.00
	T/YSC072AW	1	575	3	1.00	1.70	13.20	1	575	3	2.00	2.50	18.20
	T/YSC072AK	1	380	3	2.00	4.9	35.0	—	—	—	—	—	—
7½	T/YSC090A3	1	208-230	3	2.00	6.30	48.00	1	208-230	3	3.00	9.40	83.00
	T/YSC090A4	1	460	3	2.00	3.10	24.00	1	460	3	3.00	4.60	42.00
	T/YSC090AW	1	575	3	2.00	2.50	18.20	1	575	3	3.00	3.70	31.00
	T/YSC090AK	1	380	3	2.00	4.9	35.0	1	380	3	3.0	6.4	51.1
	T/YSC092A3	1	208-230	3	2.00	6.30	48.00	1	208-230	3	3.00	9.40	83.00
	T/YSC092A4	1	460	3	2.00	3.10	24.00	1	460	3	3.00	4.60	42.00
8½	T/YSC102A3	1	208-230	3	2.00	6.30	48.00	1	208-230	3	3.00	9.40	83.00
	T/YSC102A4	1	460	3	2.00	3.10	24.00	1	460	3	3.00	4.60	42.00
	T/YSC102AW	1	575	3	2.00	2.50	18.20	1	575	3	3.00	3.70	31.00
	T/YSC102AK	1	380	3	2.00	4.9	35.0	1	380	3	3.0	6.4	51.1
10	T/YSC120A3	1	208-230	3	3.00	9.40	83.00	1	208-230	3	5.00	13.40	112.00
	T/YSC120A4	1	460	3	3.00	4.60	42.00	1	460	3	5.00	6.60	56.00
	T/YSC120AW	1	575	3	3.00	3.70	31.00	1	575	3	5.00	5.40	44.0
	T/YSC120AK	1	380	3	3.00	6.4	51.1	1	380	3	5.0	10.8	66.5

<sup>(1)</sup> Standard and Oversized Motor for 3-5 ton is Direct Drive. 6-10 ton is Belt Drive.

**Table 141. Electrical Characteristics — Evaporator Fan Motor — 60 Cycle — Optional Belt Drive**

Tons	Unit Model Number	No.	Volts	Phase	HP	Amps	
						FLA	LRA
3	T/YSC036A3	1	208-230	3	1.00	5.00	32.20
	T/YSC036A4	1	460	3	1.00	2.50	16.10
	T/YSC036AW	1	575	3	1.00	1.70	13.20
4	T/YSC048A3	1	208-230	3	1.00	5.00	32.20
	T/YSC048A4	1	460	3	1.00	2.50	16.10
	T/YSC048AW	1	575	3	1.00	1.70	13.20
5	T/YSC060A3	1	208-230	3	1.00	5.00	32.20
	T/YSC060A4	1	460	3	1.00	2.50	16.10
	T/YSC060AW	1	575	3	1.00	1.70	13.20

**Table 142. Electrical Characteristics — Power Exhaust (Cooling and Gas/Electric)**

Tons	Volts	Phase	HP	RPM <sup>(1)</sup>	FLA	LRA
6-10	208-230	1	0.87	1075	5.7	16.3
6-10	460	1	0.87	1075	3.3	6.8
6-10	575	1	0.87	1075	2.3	5.4

<sup>(1)</sup> Two speed.



**Table 143. Unit Wiring — High Efficiency — 13 SEER**

Tons	Unit Model Number	Voltage Range	Belt Drive Indoor Fan	
			MCA	Max Fuse Size or Max Circuit Breaker
3	T/YHC033A3	187-253	19.9	30
	T/YHC033A4	414-506	10.4	15
	T/YHC033AW	517-633	7.7	15
4	T/YHC043A3	187-253	22.6	35
	T/YHC043A4	414-506	11.8	15
	T/YHC043AW	517-633	8.5	15
5	T/YHC063A3	187-253	28.8	45
	T/YHC063A4	414-506	14.3	20
	T/YHC063AW	517-633	11.4	15

**Table 144. Unit Wiring with Gas Heat or Cooling (No Electric Heat)**

Tons	Unit Model Number	Unit Operating Voltage Range	Standard Indoor Fan Motor		Oversize Indoor Fan Motor		Belt Drive Indoor Fan Motor <sup>(i)</sup>	
			Minimum Circuit Ampacity	Maximum Fuse Size or Maximum Circuit Breaker	Minimum Circuit Ampacity	Maximum Fuse Size or Maximum Circuit Breaker <sup>(ii)</sup>	Minimum Circuit Ampacity	Maximum Fuse Size or Maximum Circuit Breaker
6	T/YHC072A3	187-253	34.8	50	36.1	50	—	—
	T/YHC072A4	414-506	17.5	25	18.1	25	—	—
	T/YHC072AW	517-633	13.5	20	14.3	20	—	—
7½	T/YHC092A3	187-253	38.1	50	41.2	50	—	—
	T/YHC092A4	414-506	19.4	25	20.9	25	—	—
	T/YHC092AW	517-633	14.8	15	16.0	20	—	—
8½	T/YHC102A3	187-253	42.3	50	45.4	60	—	—
	T/YHC102A4	414-506	21.4	25	22.9	30	—	—
	T/YHC102AW	517-633	16.6	20	17.8	25	—	—
10	T/YHC120A3	187-253	48.6	60	52.6	60	—	—
	T/YHC120A4	414-506	25.3	30	27.3	35	—	—
	T/YHC120AW	517-633	19.9	25	21.6	25	—	—

<sup>(i)</sup> The Standard Motor for 6-10 ton models is Belt Drive.

<sup>(ii)</sup> For standard and oversized motors, HACR breaker per NEC.

**Table 145. Unit Wiring With Electric Heat (Single Point Connection) 13 SEER — Belt Drive — High Efficiency**

Tons	Unit Model Number	Heater Model Number	Heater kW Rating	Control Stages	Belt Drive Indoor Motor	
					MCA	Max Fuse Size or Max Circuit Breaker
208/230 Volts Three Phase						
3	THC033A3	BAYHTRR306A	4.5/6.0	1	21.9/24.3	25/25
		BAYHTRR312A	9.0/12.0	2	37.5/42.4	40/45
		BAYHTRR318A	13.1/17.4	2	51.6/58.6	60/60
4	THC043A3	BAYHTRR306A	4.5/6.0	1	22.6/24.3	35/35
		BAYHTRR312A	9.0/12.0	2	37.5/42.4	40/45
		BAYHTRR318A	13.1/17.4	2	51.6/58.6	60/60
5	THC063A3	BAYHTRR306A	4.5/6.0	1	28.8/28.8	45/45
		BAYHTRR312A	9.0/12.0	2	37.5/42.4	45/45
		BAYHTRR318A	13.1/17.4	2	51.6/58.6	60/60
		BAYHTRR323A	17.3/23.0	2	66.3/75.4	70/80
460 Volts Three Phase						
3	THC033A4	BAYHTRR406A	6.0	1	12.1	15
		BAYHTRR412A	12.0	2	21.1	25
		BAYHTRR418A	17.4	2	29.3	30
4	THC043A4	BAYHTRR406A	6.0	1	12.1	15
		BAYHTRR412A	12.0	2	21.1	25
		BAYHTRR418A	17.4	2	29.3	30

**Electrical Data**

*(High Efficiency)*

**Table 145. Unit Wiring With Electric Heat (Single Point Connection) 13 SEER – Belt Drive – High Efficiency (continued)**

Tons	Unit Model Number	Heater Model Number	Heater kW Rating	Control Stages	Belt Drive Indoor Motor	
					MCA	Max Fuse Size or Max Circuit Breaker
5	THC063A4	BAYHTRR406A	6.0	1	14.3	20
		BAYHTRR412A	12.0	2	21.1	25
		BAYHTRR418A	17.4	2	29.3	30
		BAYHTRR423A	23.0	2	37.8	40
575 Volts Three Phase						
3	THC033AW	BAYHTRRW06A	6.0	1	9.3	15
		BAYHTRRW12A	12.0	2	16.6	20
		BAYHTRRW18A	17.4	2	23.1	25
4	THC043AW	BAYHTRRW06A	6.0	1	9.3	15
		BAYHTRRW12A	12.0	2	16.6	20
		BAYHTRRW18A	17.4	2	23.1	25
5	THC063AW	BAYHTRRW06A	6.0	1	11.4	15
		BAYHTRRW12A	12.0	2	16.6	20
		BAYHTRRW18A	17.4	2	23.1	25
		BAYHTRRW23A	23.0	2	29.8	30

**Table 146. Unit Wiring with Electric Heat (Single Point Connection) – Standard and Oversized Motor**

Tons	Unit Model Number	Heater Model Number	Heater kW Rating <sup>(i)</sup>	Control Stages	Standard Indoor Motor		Oversize Indoor Motor	
					MCA	Max Fuse Size or Max Circuit Breaker <sup>(ii)</sup>	MCA	Max Fuse Size or Max Circuit Breaker
208/230 Volts Three Phase								
6	THC072A3	BAYHTRS309A	6.8/9.0	1	34.8/34.8	50/50	35.7/35.7	50/50
		BAYHTRS318A	13.5/18.0	1	53.1/60.4	60/70	54.8/62.0	60/70
		BAYHTRS327A	20.3/27.0	2	76.6/87.5	80/90	78.3/89.1	80/90
		BAYHTRS336A	27.0/36.0	2	100.1/114.5	110/125	101.8/116.1	110/125
7½	THC092A3	BAYHTRT309A	6.8/9.0	1	38.1/38.1	50/50	44.2/44.2	50/50
		BAYHTRT318A	13.5/18.0	1	54.8/62.0	60/70	58.6/65.9	60/70
		BAYHTRT327A	20.3/27.0	2	78.3/89.1	80/90	82.1/93.0	90/100
		BAYHTRT336A	27.0/36.0	2	101.8/116.1	110/125	105.6/120.0	110/125
8½	THC102A3	BAYHTRT309A	6.8/9.0	1	42.3/42.3	50/50	44.2/44.2	50/50
		BAYHTRT318A	13.5/18.0	1	54.8/62.0	60/70	58.6/65.9	60/70
		BAYHTRT327A	20.3/27.0	2	78.3/89.1	80/90	82.1/93.0	90/100
		BAYHTRT336A	27.0/36.0	2	101.8/116.1	110/125	105.6/120.0	110/125
10	THC120A3	BAYHTRT318A	13.5/18.0	1	58.6/65.9	60/70	63.6/70.9	70/80
		BAYHTRT327A	20.3/27.0	2	82.1/93.0	90/100	87.1/98.0	90/100
		BAYHTRT336A	27.0/36.0	2	105.6/120.0	110/125	110.6/125.0	125/125
		BAYHTRT354A	40.6/54.0	2	152.5/141.7	175/150	157.5/146.7	175/150
460 Volts Three Phase								
6	THC072A4	BAYHTRS409A	9.0	1	17.5	25	18.1	25
		BAYHTRS418A	18.0	1	30.3	35	31.0	35
		BAYHTRS427A	27.0	2	43.8	45	44.5	45
		BAYHTRS436A	36.0	2	57.3	60	58.0	60
7½	THC092A4	BAYHTRT409A	9.0	1	19.4	25	20.9	25
		BAYHTRT418A	18.0	1	31.0	35	32.9	35
		BAYHTRT427A	27.0	2	44.5	45	46.4	50
		BAYHTRT436A	36.0	2	58.0	60	59.9	60
8½	THC102A4	BAYHTRT409A	9.0	1	21.4	25	22.9	30
		BAYHTRT418A	18.0	1	31.0	35	32.9	35
		BAYHTRT427A	27.0	2	44.5	45	46.4	50
		BAYHTRT436A	36.0	2	58.0	60	59.9	60

## Electrical Data

*(High Efficiency)*

**Table 146. Unit Wiring with Electric Heat (Single Point Connection) — Standard and Oversized Motor (continued)**

Tons	Unit Model Number	Heater Model Number	Heater kW Rating <sup>(iii)</sup>	Control Stages	Standard Indoor Motor		Oversize Indoor Motor	
					MCA	Max Fuse Size or Max Circuit Breaker <sup>(iv)</sup>	MCA	Max Fuse Size or Max Circuit Breaker
10	THC120A4	BAYHTRT418A	18.0	1	32.9	35	35.4	40
		BAYHTRT427A	27.0	2	46.4	50	48.9	50
		BAYHTRT436A	36.0	2	59.9	60	62.4	70
		BAYHTRT454A	54.0	2	70.8	80	73.3	80
575 Volts Three Phase								
6	THC072AW	BAYHTRSW09A	9.0	1	13.5	20	14.3	20
		BAYHTRSW18A	18.0	1	23.8	25	24.8	25
		BAYHTRSW27A	27.0	2	34.6	35	35.6	40
		BAYHTRSW36A	36.0	2	45.4	50	46.4	50
7½	THC092AW	BAYHTRTW18A	18.0	1	24.8	25	26.3	30
		BAYHTRTW27A	27.0	2	35.6	40	37.1	40
		BAYHTRTW36A	36.0	2	46.4	50	47.9	50
8½	THC102AW	BAYHTRTW18A	18.0	1	24.8	25	26.3	30
		BAYHTRTW27A	27.0	2	35.6	40	37.1	40
		BAYHTRTW36A	36.0	2	46.4	50	47.9	50
10	THC120AW	BAYHTRTW18A	18.0	1	26.3	30	28.4	30
		BAYHTRTW27A	27.0	2	37.1	40	39.3	40
		BAYHTRTW36A	36.0	2	47.9	50	50.0	50
		BAYHTRTW54A	54.0	2	56.6	60	58.8	70

- (i) For standard and oversized motors, HACR breaker per NEC.
- (ii) Standard and Oversized Motor for 3-5 ton is Direct Drive. 6-10 ton is Belt Drive.
- (iii) For standard and oversized motors, HACR breaker per NEC.
- (iv) Standard and Oversized Motor for 3-5 ton is Direct Drive. 6-10 ton is Belt Drive.

**Table 147. Electrical Characteristics — Compressor Motor and Condenser Motor — 60 Cycle — High Efficiency — 13 SEER**

Tons	Unit Model Number	Compressor Motors						Condenser Fan Motors					
		No.	Volts	Phase	HP <sup>(ii)</sup>	RPM	Amps <sup>(i)</sup>		No.	Phase	HP	Amps	
							RLA	LRA				FLA	LRA
3	T/YHC033A3	1	208-230	3	2.8	3450	10.7	77.0	1	1	.20	1.5	2.5
	T/YHC033A4	1	460	3	2.8	3450	5.8	39.0	1	1	.20	0.6	1.3
	T/YHC033AW	1	575	3	2.8	3450	4.4	31.0	1	1	.20	0.5	1.2
4	T/YHC043A3	1	208-230	3	3.5	3450	12.5	88.0	1	1	.33	2.0	6.6
	T/YHC043A4	1	460	3	3.5	3450	6.5	44.0	1	1	.33	1.2	2.5
	T/YHC043AW	1	575	3	3.5	3450	4.9	34.0	1	1	.33	0.7	1.5
5	T/YHC063A3	1	208-230	3	4.5	3450	17.4	124.0	1	1	.33	2.0	6.6
	T/YHC063A4	1	460	3	4.5	3450	7.8	59.6	1	1	.33	1.2	2.5
	T/YHC063AW	1	575	3	4.5	3450	6.2	49.4	1	1	.33	0.9	1.5
6	T/YHC072A3	1	208-230	3	5.7	3450	20.7	156	1	1	.70	3.85	9.30
	T/YHC072A4	1	460	3	5.7	3450	10	75	1	1	.70	2.50	5.80
	T/YHC072AW	1	575	3	5.7	3450	8.2	54	1	1	.70	1.54	3.60
7½	T/YHC092A3	2	208-230	3	3.5/3.3	3450	12.4/12.4	88/88	1	1	.70	3.85	9.30
	T/YHC092A4	2	460	3	3.5/3.3	3450	6.4/5.8	44/44	1	1	.70	2.50	5.80
	T/YHC092AW	2	575	3	3.5/3.3	3450	4.8/4.8	34/34	1	1	.70	1.54	3.60
8½	T/YHC102A3	2	208-230	3	3.9/3.5	3450	14.7/12.4	91/88	1	1	.75	4.0	9.4
	T/YHC102A4	2	460	3	3.9/3.5	3450	7.1/6.4	50/44	1	1	.75	2.8	6.8
	T/YHC102AW	2	575	3	3.9/3.5	3450	5.4/4.8	37/34	1	1	.75	2.4	6.2
10	T/YHC120A3	2	208-230	3	4.8/3.5	3450	17.3/12.4	124/88	1	1	.75	4.0	9.4
	T/YHC120A4	2	460	3	4.8/3.5	3450	9.0/6.4	59.6/44	1	1	.75	2.8	6.8
	T/YHC120AW	2	575	3	4.8/3.5	3450	7.1/4.8	49.4/34	1	1	.75	2.4	6.2

- (i) Amp draw for each motor; multiply value by number of motors to determine total amps.
- (ii) HP for each compressor.

## Electrical Data

*(High Efficiency)*

**Table 148. Electrical Characteristics — Evaporator Fan Motor — 60 Cycle — Standard and Oversized Motor<sup>(1)</sup>**

Tons	Unit Model Number No.		Standard Evaporator Fan Motor						Oversized Evaporator Fan Motor					
			Volts	Phase	HP	RLA	Amps		Volts	Phase	HP	Amps		
							LRA	No.				FLA	LRA	
6	T/YHC072A3	1	208-230	3	1.00	5.00	32.20	1	208-230	3	2.00	6.30	48.00	
	T/YHC072A4	1	460	3	1.00	2.50	16.10	1	460	3	2.00	3.10	24.00	
	T/YHC072AW	1	575	3	1.00	1.70	13.20	1	575	3	2.00	2.50	18.20	
7½	T/YHC090A3	1	208-230	3	2.00	6.30	48.00	1	208-230	3	3.00	9.40	83.00	
	T/YHC090A4	1	460	3	2.00	3.10	24.00	1	460	3	3.00	4.60	42.00	
	T/YHC090AW	1	575	3	2.00	2.50	18.20	1	575	3	3.00	3.70	31.00	
	T/YHC092A3	1	208-230	3	2.00	6.30	48.00	1	208-230	3	3.00	9.40	83.00	
	T/YHC092A4	1	460	3	2.00	3.10	24.00	1	460	3	3.00	4.60	42.00	
	T/YHC092AW	1	575	3	2.00	2.50	18.20	1	575	3	3.00	3.70	31.00	
8½	T/YHC102A3	1	208-230	3	2.00	6.30	48.00	1	208-230	3	3.00	9.40	83.00	
	T/YHC102A4	1	460	3	2.00	3.10	24.00	1	460	3	3.00	4.60	42.00	
	T/YHC102AW	1	575	3	2.00	2.50	18.20	1	575	3	3.00	3.70	31.00	
10	T/YHC120A3	1	208-230	3	3.00	9.40	83.00	1	208-230	3	5.00	13.40	112.00	
	T/YHC120A4	1	460	3	3.00	4.60	42.00	1	460	3	5.00	6.60	56.00	
	T/YHC120AW	1	575	3	3.00	3.70	31.00	1	575	3	5.00	5.40	44.0	

<sup>(1)</sup> Standard and Oversized Motor for 3-5 ton is Direct Drive. 6-10 ton is Belt Drive.

**Table 149. Electrical Characteristics — Evaporator Fan Motor — 60 Cycle — Belt Drive — 13 SEER**

Tons	Unit Model Number		Volts	Hz.	Phase	No.	HP	Amps	
								FLA	RLA
3	T/YHC033A3		208-230	60	3	1	1.00	5.00	32.20
	T/YHC033A4		460	60	3	1	1.00	2.50	16.10
	T/YHC033AW		575	60	3	1	1.00	1.70	13.20
4	T/YHC043A3		208-230	60	3	1	1.00	5.00	32.20
	T/YHC043A4		460	60	3	1	1.00	2.50	16.10
	T/YHC043AW		575	60	3	1	1.00	1.70	13.20
5	T/YHC063A3		208-230	60	3	1	1.00	5.00	32.20
	T/YHC063A4		460	60	3	1	1.00	2.50	16.10
	T/YHC063AW		575	60	3	1	1.00	1.70	13.20

**Table 150. Electrical Characteristics — Power Exhaust (Cooling and Gas/Electric)**

Tons	Volts	Phase	HP	RPM <sup>(1)</sup>	FLA	LRA
6-10	208-230	1	0.87	1075	5.7	16.3
6-10	460	1	0.87	1075	3.3	6.8
6-10	575	1	0.87	1075	2.3	5.4

<sup>(1)</sup> Two Speed.

**Table 151. Electrical Characteristics — Inducer Motor**

Unit Model Number	Stages	HP	RPM	Volts	Phase	LRA
<sup>(1)</sup> YHC033-063A	1	1/35	2750	208-230	1	0.6
YHC072A*L,M YHC090,092,102A*L	1	1/35	3000/3000	208-230	1	0.6
YHC072A*H YHC090, 092,102A*M,H YHC120A*L,M,H	2	1/15	3500	208-230	1	0.42

<sup>(1)</sup> 13 SEER

# Jobsite Connections

---

**Table 152. Typical Number of Wires**

**Zone Sensors**

<b>A</b>	Manual Changeover.....	4
	Manual/Auto Changeover.....	5
	Manual/Auto Changeover with Status Indication LED's.....	10
	Programmable Night Setback with Status Indication LED's.....	7

**Thermostats**

<b>A</b>	4 Wires, 24-volts
<b>B</b>	3 Power Wires + 1 Ground Wire (three phase)

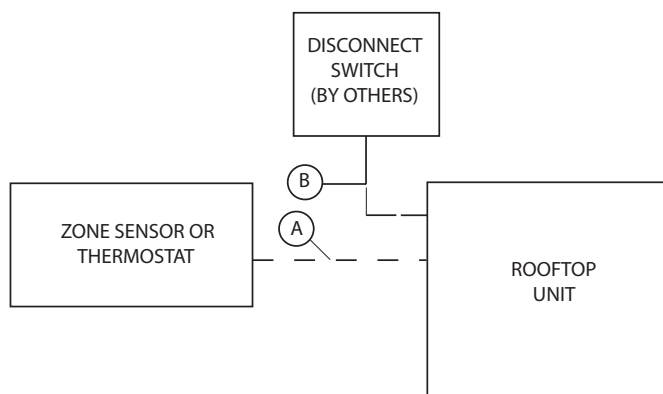

For specific wiring information, see the installation instructions.

All wiring except power wire is low voltage.

All customer supplied wiring to be copper and must conform to applicable electrical codes (such as NEC or CEC) and local electric codes. Wiring shown dotted is to be furnished and installed by the customer.

# Dimensional Data

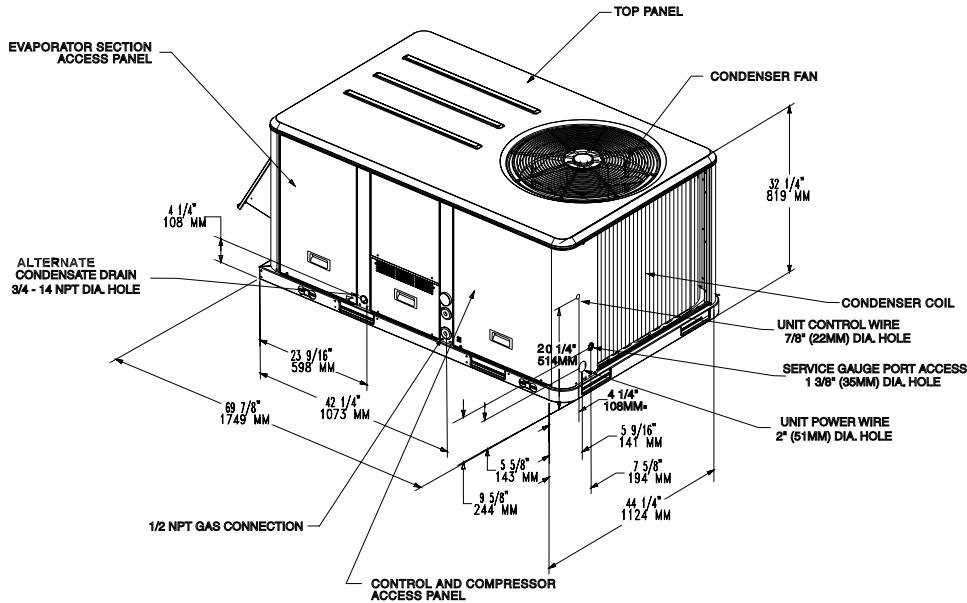

**Figure 2. Cooling with Optional Electric Heat and Gas/Electric Models - 3-5 Tons Standard Efficiency Low and Medium Heat; 3-4 Tons Low and Medium Heat – 13 SEER**

\* All dimensions are in inches/millimeters.  
 \*\*1/2 NPT Gas Connection = (Y\_C Models only); 2" Electrical Connection: Single Point Power When Heat Installed (T\_C Models only.)

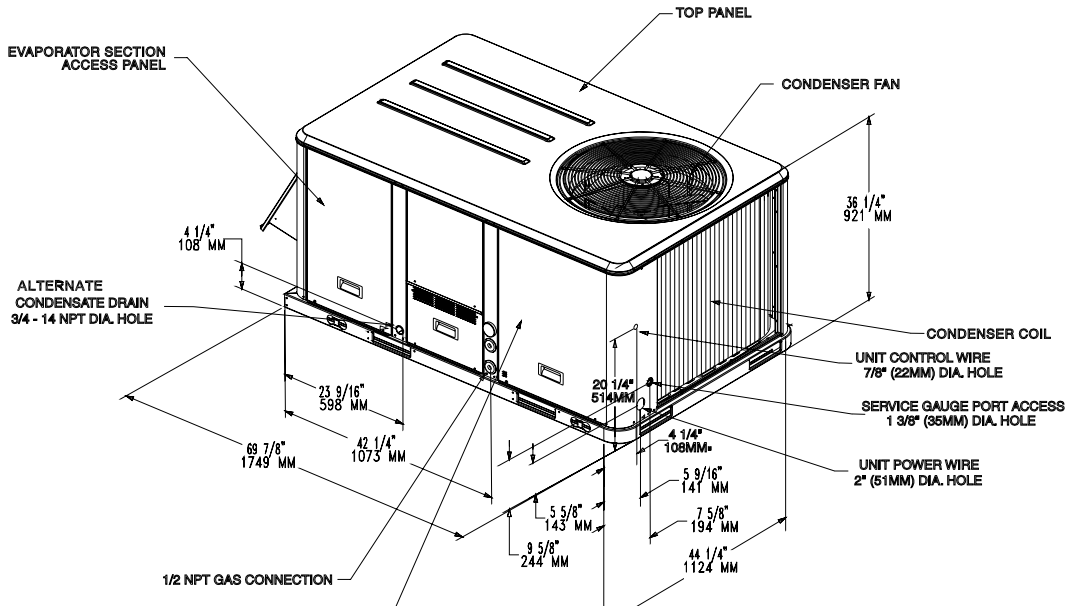

**Figure 3. Cooling with Optional Electric Heat and Gas/Electric Models - 3-5 Tons Standard Efficiency High Heat; 5 Tons – High Heat – 13 SEER**

\* All dimensions are in inches/millimeters.  
 \*\*1/2 NPT Gas Connection = (Y\_C Models only); 2" Electrical Connection: Single Point Power When Heat Installed (T\_C Models only.)

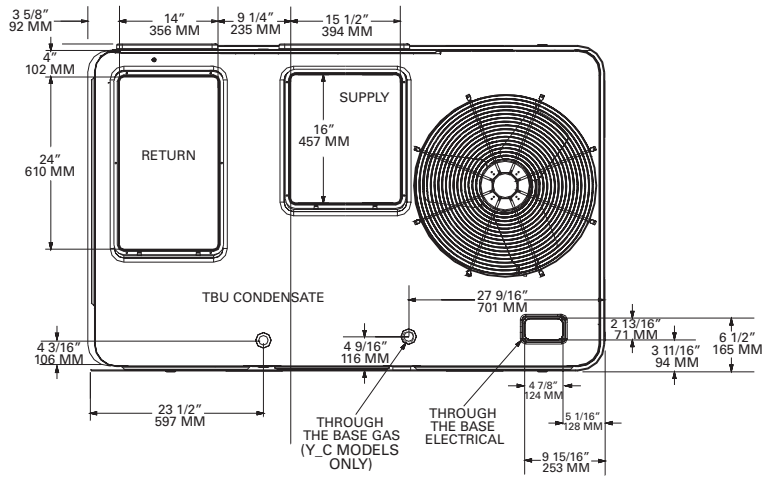

**Figure 4. Cooling with Optional Electric Heat and Gas/Electric Models 3-5 Tons; 3-5 Tons 13 SEER- Downflow Airflow Supply/Return - Through the Base Utilities**

\* All dimensions are in inches/millimeters.

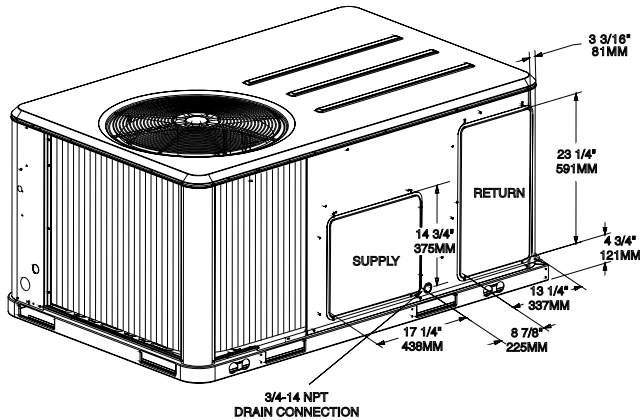

**Figure 5. Cooling with Optional Electric Heat and Gas/Electric Models 3-5 Tons; 3-5 Tons 13 SEER - Horizontal Airflow Supply/Return**

\* All dimensions are in inches/millimeters.

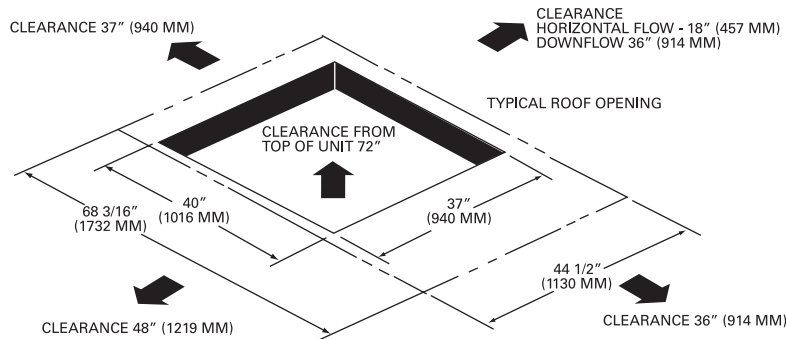

**Figure 6. Cooling with Optional Electric Heat and Gas/Electric Models 3-5 Tons; 3-5 Tons 13 SEER - Unit Clearance and Roof Opening**

\* All dimensions are in inches/millimeters.

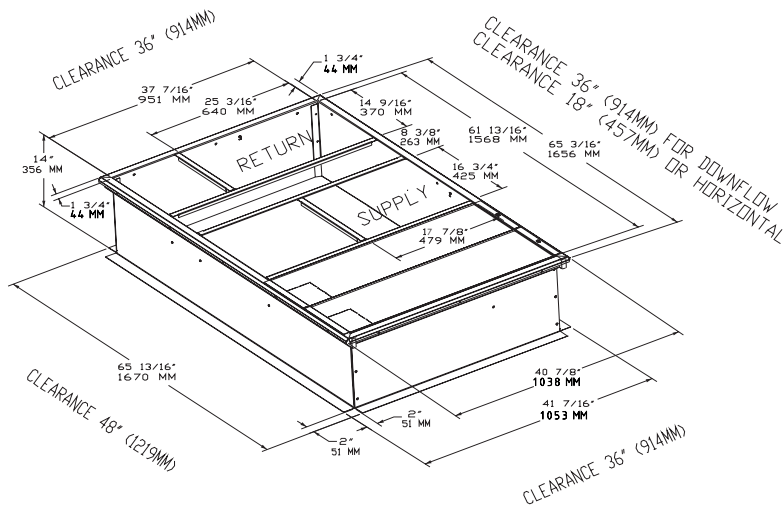

**Figure 7. Cooling with Optional Electric Heat and Gas/Electric Models**  
**3-5 Tons; 3-5 Tons 13 SEER - Roof Curb**

\* All dimensions are in inches/millimeters.

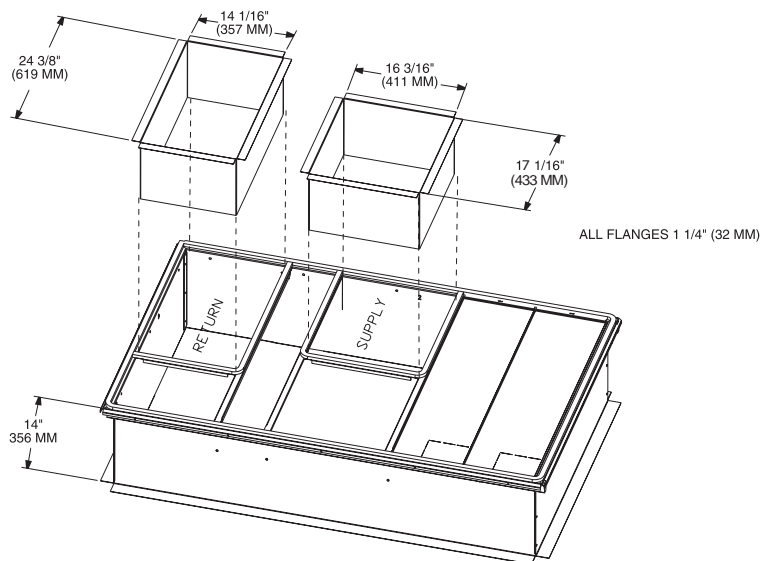

**Figure 8. Cooling with Optional Electric Heat and Gas/Electric Models**  
**3-5 Tons; 3-5 Tons 13 SEER - Downflow Duct Connections - Field Fabricated**

\* All dimensions are in inches/millimeters.



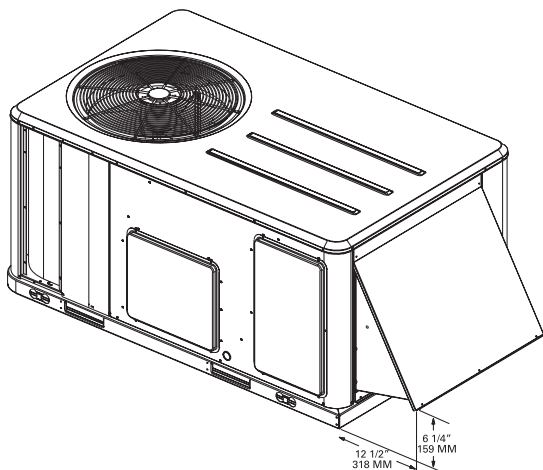

**Figure 9. Cooling with Optional Electric Heat and Gas/Electric Models - 3-5 Tons; 3-5 Tons 13 SEER - Economizer, Manual or Motorized Fresh Air Damper**

\* All dimensions are in inches/millimeters.

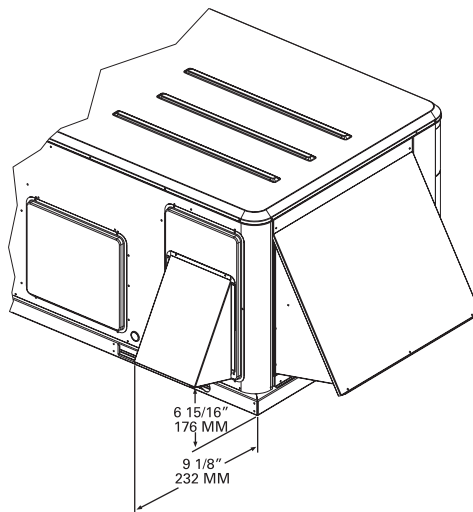

**Figure 11. Cooling with Optional Electric Heat and Gas/Electric Models - 3-5 Tons; 3-5 Tons 13 SEER Economizer & Barometric Relief Damper Hood**

\* All dimensions are in inches/millimeters.

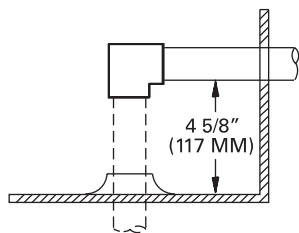

**Figure 10. Gas/Electric Models - 3-5 Tons; 3-5 Tons 13 SEER Height of Gas Pipe required from Inside Base of Unit to Gas Shut off assembly (Factory Provided) - Y\_C Models only**

\* All dimensions are in inches/millimeters.

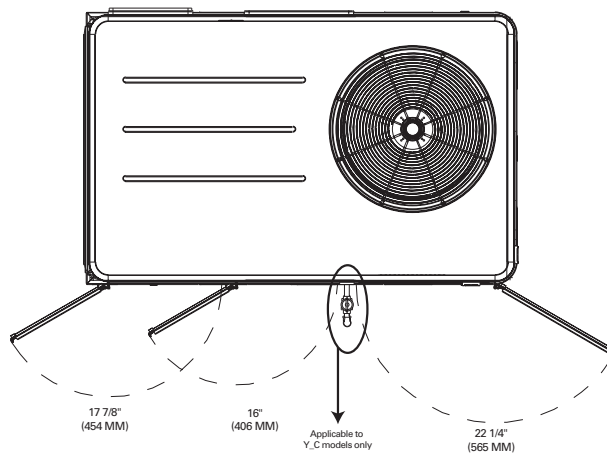
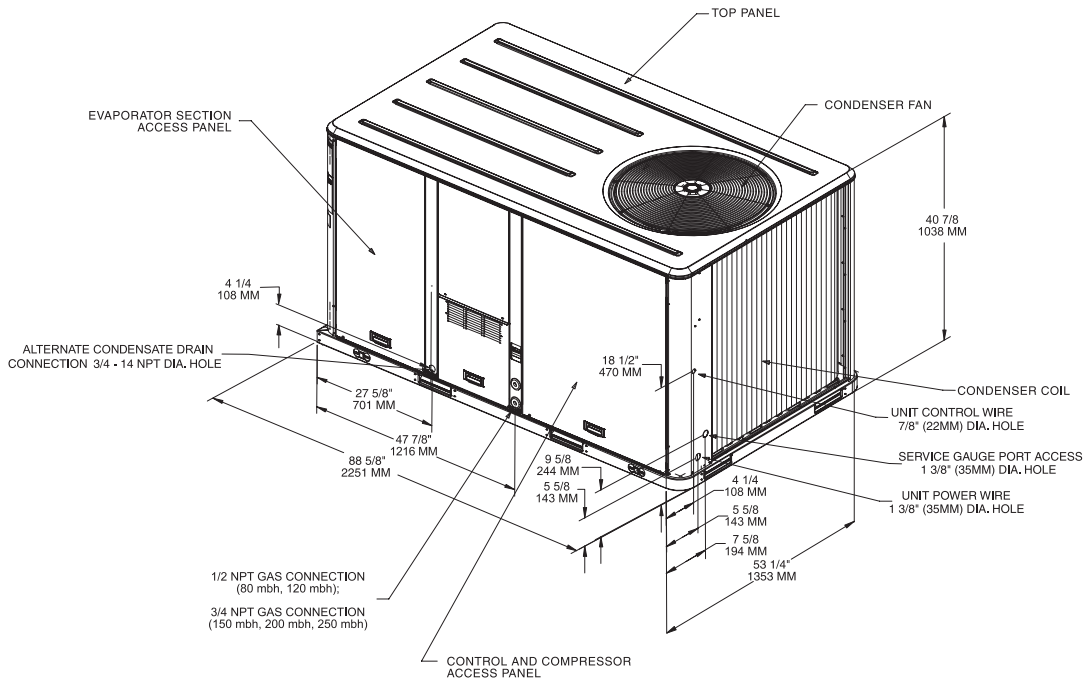

**Figure 12. Cooling with Optional Electric Heat and Gas/Electric Models - 3-5 Tons; 3-5 Tons 13 SEER Swing Diameter for Hinged Door(s) Option**

\* All dimensions are in inches/millimeters.

**Dimensional Data**

*(Standard and High Efficiency)*



**Figure 13. Cooling with Optional Electric Heat and Gas/Electric Models - 6 Tons Standard and High Efficiency; 7½ Tons Standard Efficiency**

\* All dimensions are in inches/millimeters.  
 \*\*1/2 NPT & 3/4" Gas Connection = (Y\_C Models only); 2" Electrical Connection: Single Point Power When Heat Installed (T\_C Models only.)

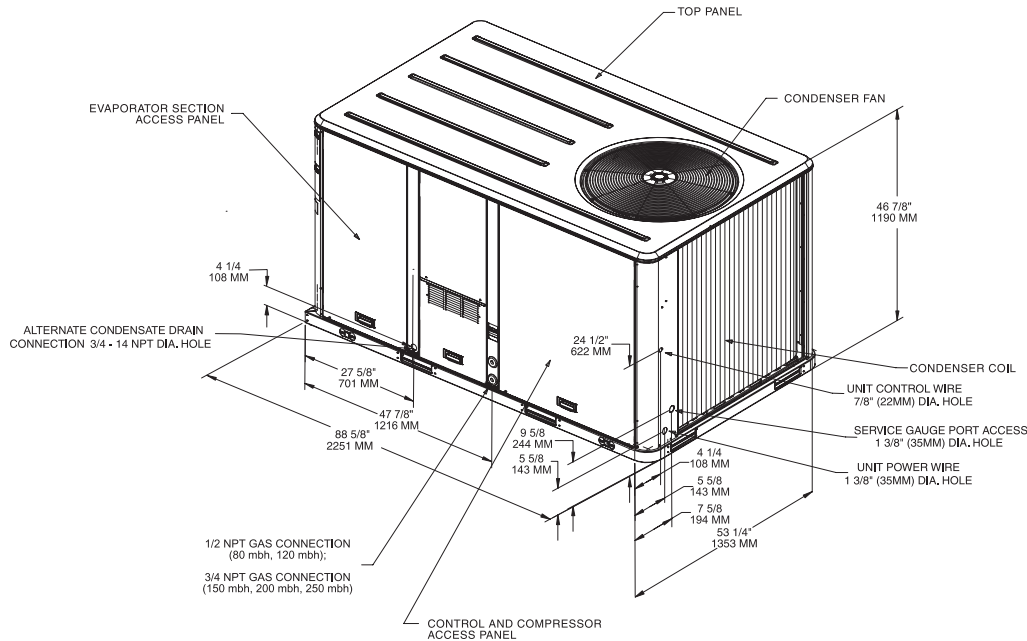

**Figure 14. Cooling with Optional Electric Heat and Gas/Electric Models - 7½ Tons High Efficiency; 8½ and 10 Tons Standard and High Efficiency**

\* All dimensions are in inches/millimeters.  
 \*\*1/2 NPT & 3/4" Gas Connection = (Y\_C Models only); 2" Electrical Connection: Single Point Power When Heat Installed (T\_C Models only.)



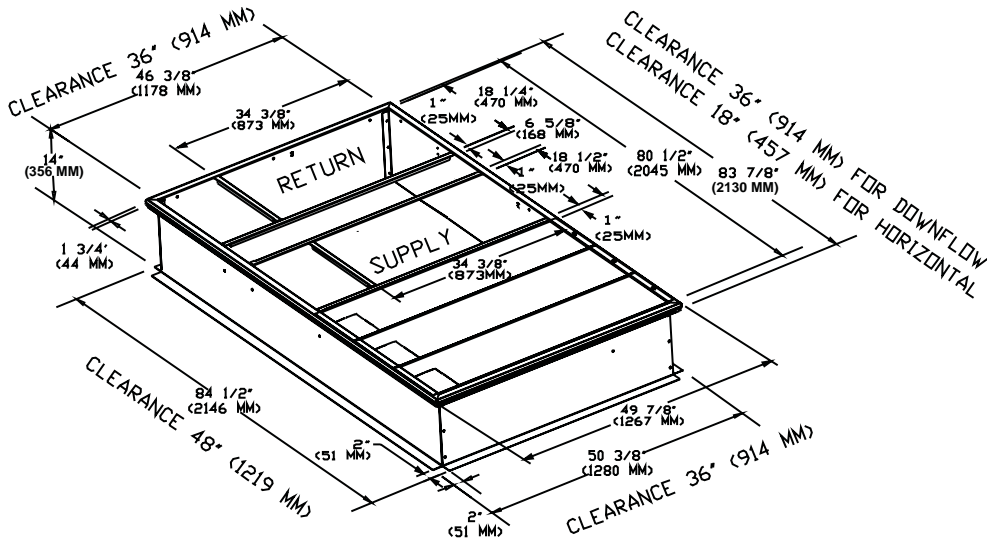

**Figure 18. Cooling with Optional Electric Heat and Gas/Electric Models - 6-10 Tons Roof Curb**

\* All dimensions are in inches/millimeters.

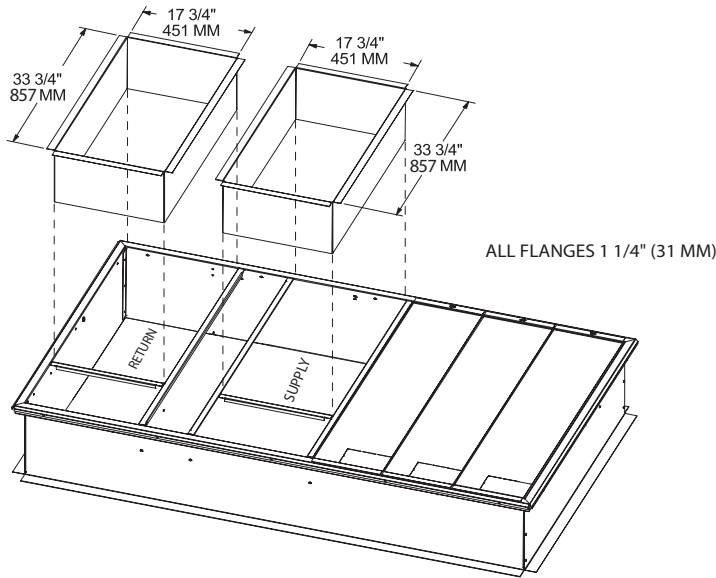
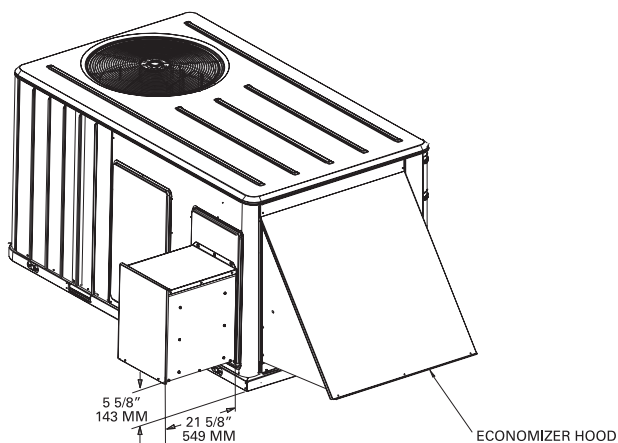

**Figure 19. Cooling with Optional Electric Heat and Gas/Electric Models 6-10 Tons - Downflow Duct Connections Field Fabricated**

\* All dimensions are in inches/millimeters.

**Dimensional Data**

*(Options/Accessories)*



**Figure 20. Cooling with Optional Electric Heat and Gas/Electric Models - 6-10 Tons Power Exhaust**

\* All dimensions are in inches/millimeters.

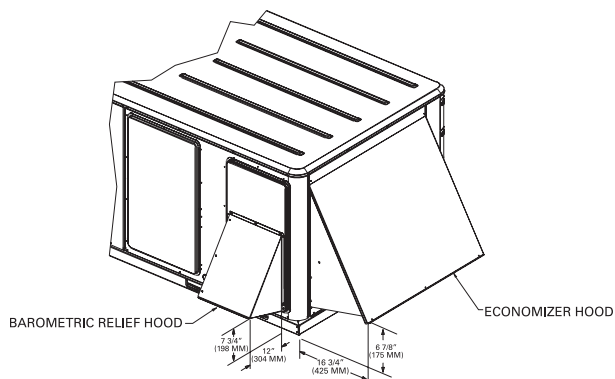

**Figure 22. Cooling with Optional Electric Heat and Gas/Electric Models - 6-10 Tons Economizer & Barometric Relief Damper Hood**

\* All dimensions are in inches/millimeters.

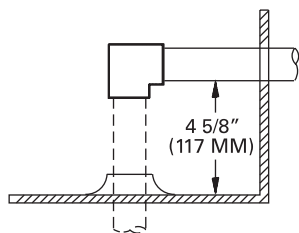

**Figure 21. Gas/Electric Models - 6-10Tons Height of Gas Pipe required from Inside Base of Unit to Gas Shut off assembly (Factory Provided) - Y\_C Models only**

\* All dimensions are in inches/millimeters.

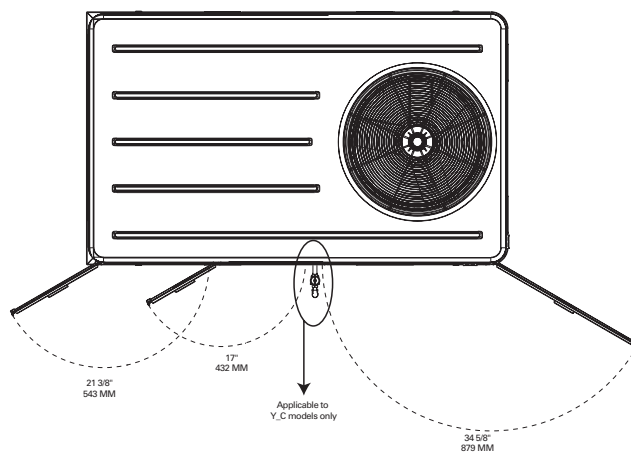

**Figure 23. Cooling with Optional Electric Heat and Gas/Electric Models - 6-10 Tons Swing Diameter for Hinged Door(s) Option**

\* All dimensions are in inches/millimeters.

# Weights

**Table 153. Maximum Unit & Corner Weights (Lbs) and Center of Gravity Dimensions (in.) Cooling with Optional Electric Heat Units only**

Tons	Unit Model No.	Basic Model Weights <sup>(i), (ii)</sup>		Corner Weights <sup>(iii)</sup>				Center of Gravity (in.)	
		Shipping	Net	A	B	C	D	Length	Width
3	TSC036A	501	409	132	104	79	94	31	19
	THC033A <sup>(iv)</sup>	566	464	140	119	109	96	32	19
4	TSC048A	526	434	140	110	91	94	33	19
	THC043A <sup>(iv)</sup>	598	507	147	124	122	112	31	20
5	TSC060A	543	451	149	114	88	99	31	18
	THC063A <sup>(iv)</sup>	648	557	167	135	130	125	31	19
6	TSC072A	824	681	236	177	119	150	38	21
	THC072A	861	718	235	182	128	173	38	22
7½	TSC090A	897	754	257	188	129	180	37	22
	TSC092A	899	756	261	202	131	162	39	21
	THC092A	1000	857	289	222	148	197	38	21
8½	TSC102A	978	835	281	223	149	181	40	21
	THC102A	1036	893	294	233	159	207	39	22
10	TSC120A	1023	880	298	238	158	187	40	21
	THC120A	1125	982	323	253	178	229	39	22

(i) Weights are approximate.

(ii) Weights do not include additional Factory or Field Installed options/accessories. For option/accessory additional weights, reference [Table 155](#) to be added to unit weights.

(iii) Corner weights are given for information only.

(iv) 13 SEER

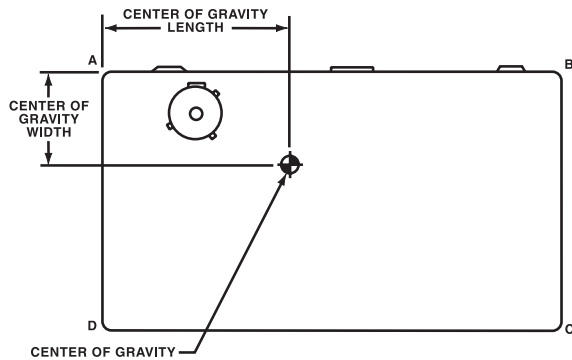

## Weights

**Table 154. Maximum Unit and Corner Weights (Lbs) and Center of Gravity Dimensions (In.) Gas/Electric Units only**

Tons	Unit Model Number	Basic Model Weights (Lbs) <sup>(i), (ii)</sup>		Corner Weights (Lbs) <sup>(iii)</sup>				Center of Gravity (In.)	
		Shipping	Net	A	B	C	D	Length	Width
3	YSC036A	572	480	151	124	96	109	32	19
	YHC033A <sup>(iv)</sup>	627	537	159	139	126	111	32	19
4	YSC048A	597	505	159	130	108	109	33	19
	YHC043A <sup>(iv)</sup>	669	577	167	144	139	127	32	20
5	YSC060A	614	522	169	134	105	114	32	18
	YHC063A <sup>(iv)</sup>	704	612	180	151	144	137	32	20
6	YSC072A	878	735	249	193	132	161	39	21
	YHC072A	915	772	249	198	141	184	39	22
7½	YSC090A	963	820	273	208	146	193	38	22
	YSC092A	965	822	277	222	147	175	40	21
	YHC092A	1066	923	306	243	165	210	39	22
8½	YSC102A	1042	899	297	243	165	194	40	21
	YHC102A	1100	957	310	252	175	220	40	22
10	YSC120A	1063	958	317	261	177	202	41	21
	YHC120A	1203	1060	342	277	197	245	40	22

(i) Weights are approximate.

(ii) Same as above.

(iii) Corner weights are given for information only.

(iv) 13 SEER

**Table 155. Factory Installed Options (FIOPS)/Accessory Net Weights (Lbs)<sup>(i), (ii)</sup>**

Accessory	Net Weight		
	3-5 Tons	3-5 Tons 13 SEER	6-10 Tons
Barometric Relief	7	7	10
Belt Drive Motor	38	38	—
Coil Guards	12	12	20
Dehumidification (Hot Gas Reheat) Coil	15	15	25
Economizer	26	26	36
Electric Heaters <sup>(iii)</sup>	15	15 <sup>(iv)</sup>	15
Hinged Doors	10	10	12
Motorized Outside Air Damper	20	20	30
Manual Outside Air Damper	16	16	26
Novar Control	8	8	8
Oversized Motor	5	—	8
Powered Convenience Outlet	38	38	38
Powered Exhaust	—	—	80
Roof Curb	70	70	115
Smoke Detector, Return	7	5	7
Smoke Detector, Supply	5	4	5
Stainless Steel Heat Exchanger <sup>(v)</sup>	4	4	6
Through the Base Electrical	8	8	13
Through the Base Gas	5	5	5
Unit Mounted Circuit Breaker	5	5	5
Unit Mounted Disconnect	5	5	5

(i) Weights for options not listed are <5 lbs.

(ii) Net weight should be added to unit weight when ordering factory-installed accessories.

(iii) Applicable to Cooling with Electric Heat Units only.

(iv) Applicable to Cooling and Heat Pump units only.

(v) Applicable to Gas/Electric Units only.

## Mechanical Specifications

### General

The units shall be convertible airflow. The operating range shall be between 115°F and 0°F in cooling as standard from the factory for units with microprocessor controls. Operating range for units with electromechanical controls shall be between 115°F and 40°F. Cooling performance shall be rated in accordance with ARI testing procedures. All units shall be factory assembled, internally wired, fully charged with R-22, and 100 percent run tested to check cooling operation, fan and blower rotation, and control sequence before leaving the factory. Wiring internal to the unit shall be colored and numbered for simplified identification. Units shall be UL listed and labeled, classified in accordance to UL 1995/ CAN/CSA No. 236-M90 for Central Cooling Air Conditioners. Canadian units shall be CSA Certified.

### Casing

Unit casing shall be constructed of zinc coated, heavy gauge, galvanized steel. Exterior surfaces shall be cleaned, phosphatized, and finished with a weather-resistant baked enamel finish. Unit's surface shall be tested 1000 hours in a salt spray test in compliance with ASTM B117. Cabinet construction shall allow for all maintenance on one side of the unit. Service panels shall have lifting handles and be removed and reinstalled by removing only a single fastener while providing a water and air tight seal. All exposed vertical panels and top covers in the indoor air section shall be insulated with a cleanable foil-faced, fire-retardant permanent, odorless glass fiber material. The base of the unit shall be insulated with 1/2 inch, 1 pound density foil-faced, closed-cell material. All insulation edges shall be either captured or sealed. The unit's base pan shall have no penetrations within the perimeter of the curb other than the raised 11/8 inch high downflow supply/return openings to provide an added water integrity precaution, if the condensate drain backs up. The base of the unit shall have provisions for

forklift and crane lifting, with forklift capabilities on three sides of the unit.

### Unit Top

The top cover shall be one piece construction or where seams exist, it shall be double-hemmed and gasket-sealed. The ribbed top adds extra strength and prevents water from pooling on unit top.

### Filters

One inch, throwaway filters shall be standard on all 3-5 ton units. The filter rack can be converted to two inch capability. Two inch filters shall be factory supplied on all 6-10 ton units. Optional 2-inch pleated filters shall be available.

### Compressors

All 3 ton standard units shall have direct-drive, hermetic, reciprocating type compressors. The reciprocating type compressors have a centrifugal oil pump providing positive lubrication to moving parts. Motor shall be suction gas-cooled and shall have a voltage utilization range of plus or minus 10 percent of unit nameplate voltage. Crankcase heater, internal temperature, and current-sensitive motor overloads shall be included for maximum protection. Compressors shall have internal spring isolation and sound muffling to minimize vibration transmission and noise. Low pressure switches shall be standard.

3 ton high efficiency and 4-10 ton standard and high efficiency units shall have direct-drive, hermetic, scroll type compressors with centrifugal type oil pumps. Motor shall be suction gas-cooled and shall have a voltage utilization range of plus or minus 10 percent of unit nameplate voltage. Internal overloads shall be provided with the scroll compressors. Crankcase heaters shall be included on 7½ ton standard efficiency units.

### Refrigerant Circuits

Each refrigerant circuit offers a choice of independent fixed orifice

expansion devices or thermal expansion valve. Service pressure ports, and refrigerant line filter driers are factory-installed as standard. An area shall be provided for replacement suction line driers.

### Evaporator and Condenser Coils

Internally finned, 5/16" copper tubes mechanically bonded to a configured aluminum plate fin shall be standard. Coils shall be leak tested at the factory to ensure the pressure integrity. The evaporator coil and condenser coil shall be leak tested to 200 psig and pressure tested to 450 psig. The condenser coil shall have a patent pending 1+1+1 hybrid coil designed with slight gaps for ease of cleaning. A removable, reversible, double-sloped condensate drain pan with provision for through the base condensate drain is standard.

### Gas Heating Section

The heating section shall have a progressive tubular heat exchanger design using stainless steel burners and corrosion resistant steel throughout. An induced draft combustion blower shall be used to pull the combustion products through the firing tubes. The heater shall use a direct spark ignition (DSI) system. On initial call for heat, the combustion blower shall purge the heat exchanger for 20 seconds before ignition. After three unsuccessful ignition attempts, the entire heating system shall be locked out until manually reset at the thermostat/zone sensor. Units shall be suitable for use with natural gas or propane (field-installed kit) and also comply with the California requirement for low NOx emissions. (Gas/Electric Only)

### Outdoor Fans

The outdoor fan shall be direct-drive, statically and dynamically balanced, draw-through in the vertical discharge position. The fan motor shall be permanently lubricated and shall have built-in thermal overload protection.



## **Mechanical Specifications**

---

### **Indoor Fan**

All 3-5 ton 3-phase units offer a choice of direct-drive, FC, centrifugal fans or belt driven, FC centrifugal fans with adjustable motor sheaves. 3-5 ton direct drive oversized motors shall be available for high static operations. All 6-10 ton units shall have belt drive motors with an adjustable idler-arm assembly for quick-adjustment to fan belts and motor sheaves. All motors shall be thermally protected. All indoor fan motors meet the U.S. Energy Policy Act of 1992 (EPACT).

### **Controls**

Unit shall be completely factory-wired with necessary controls and contactor pressure lugs or terminal block for power wiring. Unit shall provide an external location for mounting a fused disconnect device.

A choice of microprocessor or electromechanical controls shall be available.

Microprocessor controls provide for all 24 volt control functions. The resident control algorithms shall make all heating, cooling, and/or ventilating decisions in response to electronic signals from sensors measuring indoor and outdoor temperatures. The control algorithm maintains accurate temperature control, minimizes drift from set point, and provides better building comfort. A centralized

Microprocessor shall provide anti-short cycle timing and time delay between compressors to provide a higher level of machine protection.

24-volt electromechanical control circuit shall include control transformer and contactor pressure lugs for power wiring. Units shall have single point power entry as standard.

### **Factory Installed Options**

#### **Black Epoxy Pre-Coated Coils**

The black epoxy coils have a thermoset vinyl coating that is bonded to the aluminum fin stock prior to the fin-stamping process. The pre-coated coils are an economical option for protection in mildly corrosive environments.

#### **CompleteCoat™ Coils**

The cathodic epoxy type electrodisposition coating is formulated for high edge build to plate fin and tube heat exchangers. The coating is selected to provide excellent resistance and durability to corrosive effects of alkalis, acids, alcohols, petroleum, seawater, salt air and corrosive environments.

#### **Dehumidification Option**

The dehumidification (hot gas reheat) option shall provide increased dehumidification. The option shall consist of a hot-gas reheat coil located on the leaving air side of the evaporator coil prepiped and circuited.

The option shall be equipped with crankcase heater(s), low pressure switch(es), Froststat™, and a thermostatic expansion valve(s) (TXV) as standard.

#### **Heat Exchanger**

The compact cabinet features a tubular heat exchanger in low, medium and high heat capacities.

The heat exchanger is fabricated using stainless steel burners and corrosion-resistant aluminized steel tubes as standard on all models. It has an induced draft blower to pull the gas mixture through the burner tubes. The heater has a direct spark ignition system which doubles as a safety device to prove the flame.

Gas/Electric models exceed all California seasonal efficiency requirements. They also perform better than required to meet the California NOx emission requirements.

#### **Stainless Steel Heat Exchanger**

The optional stainless steel heat exchanger is constructed of 304 stainless steel. It is resistant to corrosion and oxidation and easy to clean.

The high strength to weight ratio allows for high ventilation rates with gas units. It is an excellent option to compliment the dehumidification option as a high outside air ventilation unit.

With this option, a 10-year stainless steel heat exchanger warranty is standard.

#### **High Pressure Cutout**

This is offered for units that do not have High Pressure cutout as standard. All 3-phase units with scroll compressors include High Pressure Cutout as standard.

#### **Hinged Access Doors**

Sheet metal hinges are available on the Filter/Evaporator, Supply Fan/Heat, and the Compressor/Control Access Doors.

#### **Novar Return Air Sensor**

This option, when used in conjunction with Novar Controls, will contain a factory provided and wired zone temperature sensor located in the return air stream.

#### **Novar Unit Controls**

Optional Novar rooftop unit controls shall be installed and tested. The Novar electronic thermostat module will interface to the unit microprocessor and will control the unit to the desired stage of cooling or heating.

#### **Phase Monitor**

Phase monitor shall provide 100% protection for motors and compressors against problems caused by phase loss, phase imbalance, and phase reversal. Phase monitor is equipped with an LED that provides an ON or FAULT indicator.

#### **Powered or Unpowered Convenience Outlet**

This is a GFCI, 120v/15amp, 2 plug, convenience outlet, either powered or unpowered. When the convenience outlet is powered, a service receptacle disconnect will be available. The convenience outlet is powered from the line side of the disconnect or circuit breaker, and therefore will not be affected by the position of the disconnect or circuit breaker. This option can only be ordered when the Through the Base Electrical with either the Disconnect Switch or Circuit Breaker option is ordered.

## Mechanical Specifications

---

### Supply and/or Return Air Smoke Detector

With this option, if smoke is detected, all unit operation will be shut down. Reset will be manual at the unit. Return Air Smoke Detectors require minimum allowable airflow when used with certain models. See the Installation, Operation, and Maintenance (IOM) manual for the models affected and the minimum allowable airflow required. This option is available for microprocessor controlled units.

### Thermal Expansion Valve

All units shall have a short orifice refrigerate control metering device. For more exact refrigerant flow, when using unit in low airflow applications, a Thermal Expansion Valve option shall be available.

### Through the Base Electrical Access

An electrical service entrance shall be provided allowing electrical access for both control and main power connections inside the curb and through the base of the unit. Option will allow for field installation of liquid-tight conduit and an external field-installed disconnect switch.

### Through the Base Electrical with Circuit Breaker

This option is a thermal magnetic, molded case, HACR Circuit Breaker with provisions for through the base electrical connections. The circuit breaker will be installed in a water tight enclosure in the unit with access through a swinging door. Wiring will be provided from the switch to the unit high voltage terminal block. The circuit breaker will provide overcurrent protection, be sized per NEC and UL guidelines, and be agency recognized by UL/CSA.

### Through the Base Electrical with Disconnect Switch

This 3-pole, molded case, disconnect switch with provisions for through the base electrical connections are available. The disconnect switch will be installed in the unit in a water tight enclosure with access through a swinging door. Wiring will be

provided from the switch to the unit high voltage terminal block. The switch will be UL/CSA agency recognized. Note: The disconnect switch will be sized per NEC and UL guidelines but will not be used in place of unit overcurrent protection.

### Through the Base Gas Piping

The unit shall include a standard through the base gas provision. This option shall have all piping necessary including, black steel, manual gas shut-off valve, elbows, and union. The manual shut-off valve shall include a 1/8" NPT pressure tap. This assembly will require minor field labor to install. (Gas/Electric Only)

### Two-Inch Pleated Filters

Two inch pleated media filters shall be available on all models.

### Factory or Field Installed Options

#### Clogged Filter/Fan Failure Switch

A dedicated differential pressure switch is available to achieve active fan failure indication and/or clogged filter indication. These indications will be registered with either a zone sensor with status indication lights. This option is available for microprocessor controlled units.

#### Differential Pressure Switches

These sensors allow individual fan failure and dirty filter indication for microprocessor controlled units. The fan failure switch will disable all unit functions and "flash" the Service LED on the zone sensor. The dirty filter switch will light the Service LED on the zone sensor and will allow continued unit operation.

#### Discharge Air Sensing

This option provides true discharge air sensing in heating models. This option is available for microprocessor controlled units.

#### Economizer

This accessory shall be available with or without barometric relief. The assembly includes fully modulating 0-100 percent motor and dampers, minimum position setting, preset

linkage, wiring harness with plug, spring return actuator and fixed dry bulb control. The barometric relief shall provide a pressure operated damper that shall be gravity closing and shall prohibit entrance of outside air during the equipment "off" cycle. Optional solid state or differential enthalpy control shall be available for either factory or field installation. The economizer arrives in the shipping position and shall be moved to the operating position by the installing contractor.

### Electric Heaters

Electric heat modules shall be available for installation within basic unit. Electric heater elements shall be constructed of heavy-duty nickel chromium elements internally delta connected for 240 volt, wye connected for 480 and 600 volt. Staging shall be achieved through ReliaTel™. Each heater package shall have automatically reset high limit control operating through heating element contactors. All heaters shall be individually fused from the factory, where required, and shall meet all NEC and CEC requirements when properly installed. Power assemblies shall provide single-point connection. Electric heat modules shall be UL listed or CSA certified.

### Frostat

This option is to be utilized as a safety device. The Frostat opens when temperatures on the evaporator coil fall below 10°F. The temperature will need to rise to 50°F before closing. This option should be utilized in low airflow or high outside air applications. (Cooling with Optional Electric Heat Only.)

### Oversized Motors

Direct drive oversized motors shall be available for high static applications.

### Reference or Comparative Enthalpy

Reference Enthalpy is used to measure and communicate outdoor humidity. The unit receives and uses this information to provide improved comfort cooling while using the economizer. Comparative Enthalpy measures and communicates

## **Mechanical Specifications**

---

humidity for both outdoor and return air conditions, and return air temperature. The unit receives and uses this information to maximize use of economizer cooling, and to provide maximum occupant comfort control. Reference or Comparative Enthalpy option shall be available when a factory or field installed Downflow Economizer is ordered. This option is available on all downflow models.

### **Tool-less Hail Guards**

Tool-less, hail protection quality coil guards are available for condenser coil protection.

## **Field Installed Options**

### **CO<sub>2</sub> Sensing**

The CO<sub>2</sub> sensor shall have the ability to monitor space occupancy levels within the building by measuring the parts per million of CO<sub>2</sub> (Carbon Dioxide) in the air. As the CO<sub>2</sub> levels increase, the outside air damper modulates to meet the CO<sub>2</sub> space ventilation requirements.

### **Digital Display Zone Sensor**

The Digital LCD (Liquid Crystal Display) zone sensor has the look and functionality of standard zone sensors. This sensor includes a digital display of set point adjustment and space temperature in F (Fahrenheit) or C (Celsius). Includes FAN and SYSTEM buttons (supports the service functions of the standard sensor). E-squared memory stores last programmed set points. Requires 24 VAC (Volts AC). This sensor should be utilized with ReliaTel™ controls.

### **Dual Thermistor Remote Zone Sensor**

This sensor will allow the customer to reduce the total number of remote sensors to obtain space temperature averaging. This sensor should be utilized with ReliaTel controls.

### **High Static Drive**

The high static drive option shall allow the standard motor on the 6 and 7½ ton units to operate with improved external static capabilities.

### **Humidity Sensor**

This wall-mounted humidity sensor is used to control activation of the hot gas reheat dehumidification option. The humidity sensor can be set for humidity levels between 40% and 60% relative humidity by adjusting the ReliaTel Options Module.

### **Humidity Sensor**

This duct-mounted humidity sensor is used to control activation of the hot gas reheat dehumidification option. The humidity sensor can be set for humidity levels between 40% and 60% relative humidity by adjusting the ReliaTel Options Module.

### **Manual Outside Air Damper**

This rain hood and screen shall provide up to 50 percent outside air.

### **Motorized Outside Air Dampers**

Manually set outdoor air dampers shall provide up to 50 percent outside air. Once set, outdoor air dampers shall open to set position when indoor fan starts. The damper shall close to the full closed position when indoor fan shuts down.

### **Powered Exhaust**

The powered exhaust, available for 6-10 ton units, shall provide exhaust of return air, when using an economizer, to maintain better building pressurization.

### **Remote Potentiometer**

The minimum position setting of the economizer shall be adjusted with this accessory.

### **Roof Curb**

The roof curb shall be designed to mate with the unit's downflow supply and return and provide support and a water tight installation when installed properly. The roof curb design shall allow field-fabricated rectangular supply/return ductwork to be connected directly to the curb. Curb design shall comply with NRCA requirements. Curb shall be shipped knocked down for field assembly and shall include wood nailer strips.

### **Thermostat**

Two stage heating and cooling operation or one stage heating and cooling shall be available in either manual or automatic changeover. Automatic programmable electronic with night set back shall also be available.

### **Ventilation Override Accessory**

With the Ventilation Override Accessory installed, the unit can be set to transition up to 3 different pre-programmed sequences for Smoke Purge, Pressurization, and Exhaust. The transition occurs when a binary input on the RTOM is closed (shorted). This would typically be a hard wired relay output from a smoke detector or fire control panel. The ventilation override accessory shall be available as field installed.

### **Zone Sensor**

This control shall be provided to interface with the Micro equipped units and shall be available in either manual, automatic programmable with night setback, with system malfunction lights, or remote sensor options.

cooling shall be available in either manual or automatic changeover. Automatic programmable electronic with night set back shall also be available.

*American Standard*  
HEATING & AIR CONDITIONING

**American Standard**  
**A business of American Standard Companies**  
**[www.americanstandardair.com](http://www.americanstandardair.com)**

*For more information, contact your local  
American Standard office*



---

Literature Order Number	13-1332-03
Date	3/01/07
Supersedes	13-1332-02 (07/01/06)

---

American Standard has a policy of continuous product and product data improvement and reserves the right to change design and specifications without notice.