



INSTALLATION OPERATION and MAINTENANCE MANUAL

High Efficiency Packaged Model TRS Series Air Conditioning Systems, Model Sizes 036 Thru 420

--- The TRS Series uses R- 410A Refrigerant –



TABLE OF CONTENTS

Safety Labeling and Signal Words.....	2	Clogged Filter Indicator	10
General Description	3	Convenience Outlet.....	10-11
Unpacking, Inspection	3	Exhaust Fan Interlock	11
Design Certification.....	3	Power Through the Curb	11
Codes & Ordinances	3	Firestat.....	11
Installation.....	3- 7	Sure-Trip™	11
Unit Location, Clearances	3	Unit Controller.....	11
Curb Installation	4	Sequence of Operation	11
Rigging.....	4	Hydronic and Steam Heat.....	11
Electrical.....	4-5	Electric Heat.....	11
Ductwork	5	Gas Heat	11
Condensate Piping	5	Gas Furnace.....	12-20
Gas Piping and Venting	5	ECW Wheel.....	21-22
Service Clearances	6-7	Trouble Shooting Guides.....	23-28
Cooling System Options.....	7	General Refrigeration Circuit	23-25
Hot Gas Bypass	7-8	Varispeed™ Condenser Control	25
Head Pressure Control.....	8	Hot Gas Bypass Regulator	26
Variable Speed Control	8	General Gas Furnace	27-28
Adjustable High and Low Pressure	8	Maxitrol-Regulator.....	27-28
Mechanical Adjustments	8- 10		
Evaporator Blower Fan	8- 10		
Electrical System Options	10-11		
Air Flow Switch.....	10		

! WARNING: READ SAFE OPERATION RULES AND MANUAL CAREFULLY

Insert for all ADDISON® product manuals

Instructions:

In accordance with California Proposition 65 requirements, place enclosed label(s) in a highly visible location on outside of equipment to be repaired (i.e., near equipment's serial plate). See label placement drawing in equipment's Installation, Operation and Service manual for label location (when available). Avoid placing label on areas with extreme heat, cold, corrosive chemicals or other elements. Extra labels are also included where repair of multiple units is involved. To order additional labels, please call +1.407.292.4400.

To obtain a copy of the manual or for more information, visit the applicable website(s) below:

Incluya en todos los Manuales de productos de ADDISON®

Instrucciones:

De conformidad con los requerimientos de la Propuesta 65 de California, ubique la(s) etiqueta(s) adjunta(s) en un lugar bien visible en el exterior del equipo a ser reparado (es decir, cerca de la placa serial). Ver dibujo de instalación de la etiqueta en el Manual de Operaciones y Mantenimiento (si esta disponible). Evite colocar la etiqueta en áreas con calor, frío, productos químicos corrosivos u otros elementos. Se incluyen etiquetas adicionales para el caso de reparación de varias unidades. Para ordenar etiquetas adicionales, por favor llamar al +1.407.292.4400.

Para obtener una copia del manual o para obtener mas información visite los sitios Web correspondientes a continuación.

www.addison-hvac.com

⚠ WARNING	
This equipment, its related accessories and by-products of operation, contain chemicals known to the State of California to cause cancer and birth defects or other reproductive harm.	
⚠ ADVERTENCIA	
Este equipo, sus accesorios y los productos derivados de su operación contienen productos químicos que el Estado de California considera causantes de cáncer y defectos de nacimiento u otros daños reproductivos.	
Printed in U.S.A./Impreso en EE.UU	P/N 91070015 Orig

Page 1 of 1

Installation Code and Annual Inspections: All installation and service of ADDISON® equipment must be performed by a contractor qualified in the installation and service of equipment sold and supplied by Addison and conform to all requirements set forth in the ADDISON® manuals and all applicable governmental authorities pertaining to the installation, service, operation and labeling of the equipment. To help facilitate optimum performance and safety, Addison recommends that a qualified contractor conduct, at a minimum, annual inspections of your ADDISON® equipment and perform service where necessary, using only replacement parts sold and supplied by Addison.

Further Information: Applications, engineering and detailed guidance on systems design, installation and equipment performance is available through ADDISON® representatives. Please contact us for any further information you may require, including the Installation, Operation and Service Manual.

This product is not for residential use.

This document is intended to assist licensed professionals in the exercise of their professional judgment.

Código de Instalación e Inspecciones Anuales: Todas las instalaciones y mantenimientos de productos ADDISON® deben ser realizados sólo por personal cualificado en la instalación y mantenimiento de los equipos vendidos y suministrados por Addison y/o por sus distribuidores y deben cumplir con todos los requisitos dispuestos en los manuales de ADDISON® y con todos los estándares locales aplicables a la instalación, mantenimiento, funcionamiento y etiquetado del equipo. Para conseguir un funcionamiento óptimo y seguro, Addison recomienda que un técnico cualificado revise anualmente sus equipos y realice el mantenimiento siempre que sea necesario, usando exclusivamente piezas de repuesto de ADDISON®.

Información adicional: A través de los distribuidores de Addison está disponible la información sobre aplicaciones, guías detalladas sobre diseño de sistemas e instalación y funcionamiento de los productos. Por favor contacte con nosotros si necesita más información o si requiere un manual de instalación, funcionamiento y mantenimiento.

Este producto no es para uso residencial.

La intención de este documento es la de ayudar a los profesionales autorizados en el libre ejercicio de su profesión.

Addison

7050 Overland Road
Orlando, FL 32810 U.S.A.
Telephone: +1.407.292.4400
Fax: +1.407.290.1329
www.addison-hvac.com

SAFETY LABELING AND SIGNAL WORDS

Danger, Warning and Caution

The signal words **DANGER**, **WARNING** and **CAUTION** are used to identify levels of hazard seriousness. The signal word **DANGER** is only used on product labels to signify an immediate hazard. The signal words **WARNING** and **CAUTION** will be used on product labels and throughout this manual and other manuals that may apply to the product.

Signal Words

DANGER – Immediate hazards which **WILL** result in severe personal injury or death.

WARNING – Hazards or unsafe practices which **COULD** result in severe personal injury or death.

CAUTION – Hazards or unsafe practices which **COULD** result in minor personal injury or product or property damage.

Signal Words in Manuals

The signal word **WARNING** is used throughout this manual in the following manner:



The signal word **CAUTION** is used throughout this manual in the following manner:

CAUTION

Product Labeling

Signal words are used in combination with colors and/or pictures on product labels. Following are examples of product labels with explanations of the colors used.



This unit contains HFC-(R410A), an azeotropic mixture of R-32 (Difluoromethane) and R-125 (Pentafluoroethane). **DO NOT VENT HFC-(R410A)** to the atmosphere. The U. S. Clean Air Act requires the recovery of any residual refrigerant. Do not use R-22 service equipment or components on R410A systems.

Danger Label

White lettering on a black background except the word **DANGER** which is white with a red background.



Warning Label

White lettering on a black background except the word **WARNING** which is white with an orange background.

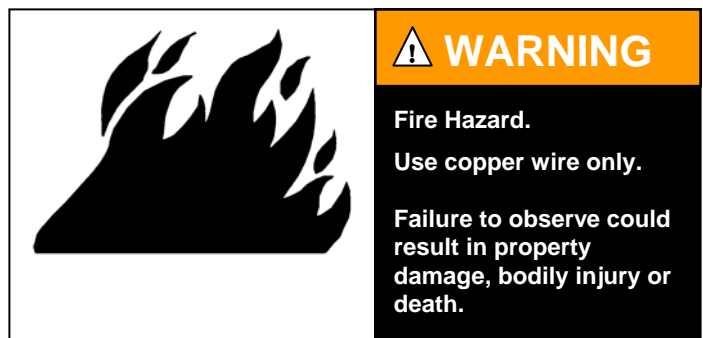

Caution Label

White lettering on a black background except the word **CAUTION** which is white with a yellow background.

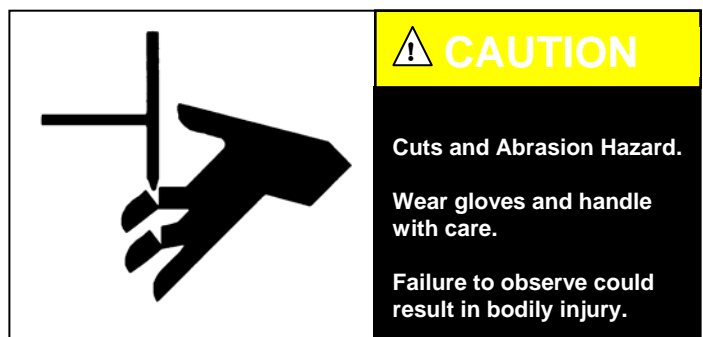

GENERAL DESCRIPTION

The model TRS Series A packaged cooling and heating unit is designed to cool a conditioned space with mechanical refrigeration, chilled water, energy conservation wheel or a combination of these systems. During the heating mode supply air may be heated by indirect fired gas, electric strip, steam or hot water. The cabinet design provides space for a number of options, including 100% outside air applications and the use of desiccant wheels. Most of these options will be covered in this manual; for those of a more custom nature, consult the ADDISON Application Engineering Department.

Model TRS units are designed for rooftop curb, slab mounted or installed on post and rail applications. Horizontal supply with 100% outside air does not require a curb and may be slab mounted. Horizontal or vertical supply with vertical return is available with a 14" high solid bottom roof curb (sold separately as an option). Horizontal supply and return air duct connections are made with the use of a 24" high solid bottom roof curb (sold separately as an option).

Unpacking, Inspection

When received, the unit should be checked for damage that might have occurred in transit. If damage is found, it should be noted on the carrier's Freight Bill. Request for inspection by carrier's agent should be made in writing at once.

Design Certification

All units are certified by Electrical Testing Laboratories (E.T.L.) under ANSI/UL 1995. The gas furnace designs are certified by E.T.L. under the appropriate ANSI standards for use with natural or propane (L.P.) gas as specified when ordering unit.

Codes and Ordinances

These units must be installed in accordance with the standard of the National Fire Protection Association or the National Fuel Gas Code. The National Fuel Gas Code is available from the American Gas Association, 1515 Wilson Boulevard, Arlington, VA 22209. NFPA Publications are available from the National Fire Protection Association, Batterymarch Park, Quincy, MA 02269. Local authorities having jurisdiction should be consulted before installations are made to verify local codes and installation procedures.

All field wiring to the unit must be done in accordance with these instructions, the National Electric Code (ANSI/NFPA 70-1981) in the United States and all local codes and ordinances.

Clearances from the heater and vent to construction or material in storage must conform with the National Fuel Gas Code, pertaining to gas-burning devices, and such material **must not attain a temperature over 160°F** by continued operation of the heater.

Installation should be done by a qualified agency in accordance with the instructions in this manual and in compliance with all codes clearances and requirements of authorities having jurisdiction.

INSTALLATION

Unit Location, Clearances

A 36" clearance must be allowed for access to the compressor and electrical panel. A 24" clearance must be maintained for the air inlet to the condenser coil(s). Do not locate the unit under an overhang that will short circuit hot air to the coil intakes.

When installed at ground level, the unit should be mounted on a level concrete slab which should extend at least 2" beyond the unit on all sides. The top of the slab should be 2" above the ground level. The depth of the slab below the ground level and its structural design is governed by the type of soil and climatic conditions. The slab must not be in contact with any part of the building wall or foundation. The space between the slab and building wall prevents the possibility of transmitting vibration to the building. The dimensions of the slab or roof mount should be checked and verified before the equipment arrives. Unit supports, roof opening, roof curb flashing, drain requirements, and electric locations are important to a good installation.

When installing the equipment on top of a building, the following should be considered. Structural members supporting the unit must be sufficiently strong for the weight of the unit and mounting rails. Transmission of sound into the building is sometimes a problem when the structure is not strong enough.

Locate the unit as near as possible to the center of the area to be environmentally controlled. Sufficient clearance must be available for service, edge of roof, other units, or hazards. The condenser air inlet and discharge air must be unobstructed by overhang, walls, or other equipment. Avoid locations next to exhaust fans or flues.

Select a location where external water drainage cannot collect around the unit. Locate the unit so roof runoff water does not pour directly on the unit. Provide gutter or other shielding at roof level.

Where snowfall is anticipated, mount the unit above the maximum snow depth for the area.

INSTALLATION (CONT'D)

Curb Installation, Protrusions

Proper installation for the TRS series requires that the roof mounting of the curb be firmly and permanently attached to the roof structure. Check for adequate fastening method prior to setting rooftop unit on curb.

Inspect curb to insure that none of the utility services (electric, gas, drain lines) routed through the curb protrude above the curb. Being a fully welded solid bottom curb, duct connections can be made before unit is set on curb. Duct openings are to be sized and cut by the installing contractor in the solid curb.

Rigging

WARNING: Be sure that the crane and lift material (bars, cable, chain), (or other lifting device) capacity is adequate for the unit weight. See Addison Products Company specification literature for unit weights. The total unit weight calculated must include all appropriate options for your unit. Certain options can add significant weight to a unit.

Spreader bars keep the lift cables from damaging the cabinet once the unit has been lifted, these bars will be required in all instances. Keep the tension equal, improper lift tension can damage wiring, refrigeration lines and the water tight integrity of the cabinet as well as sheet metal damage to the unit cabinet.

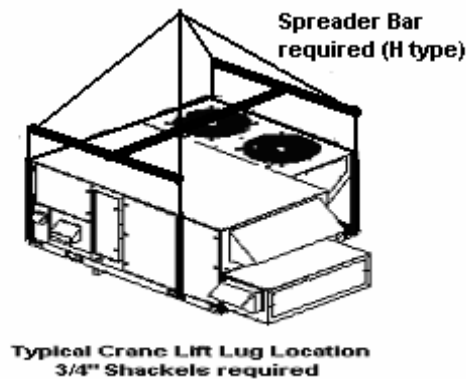

Figure 1

Lower unit carefully onto roof mounting curb or mounting rails or ground level slab. While rigging unit, center of gravity will cause condenser end to be lower than supply/return air end. Bring condenser end of unit into alignment with curb. With condenser end of unit resting on curb member and using curb as fulcrum, lower front end of unit until entire unit is seated on curb.

Rigging Removal

Remove spreader bars, lifting cables and other rigging equipment. Use caution not to dent scratch or otherwise damage cabinet or intake and exhaust hoods.

CAUTION: Do not allow crane hooks and spreader bars to rest on roof of the unit.

ELECTRICAL

Wiring Connections

Power wiring should be connected to the main power terminal block located within the unit main control section. Power wiring connections on units with factory disconnects should be made at the line side of the disconnect switch.

Low voltage wiring connections are made to the remote mounted controller or time clock.

DO NOT TAMPER WITH FACTORY WIRING

Contact your local representative or the factory if assistance is required. The internal power and control wiring of these units is factory installed and each unit is thoroughly tested prior to shipment.

Independent Power Source

It is recommended that an independent 115-volt power source be brought to the vicinity of the rooftop unit for portable lights and tools used by the service mechanic.

Main Power Wiring

The units are factory wired for the voltage shown on the nameplate.

Main power wiring should be sized for the minimum wire ampacity shown on the nameplate.

An external weather-tight disconnect switch properly sized for the unit total load is required for each unit. Disconnect must be installed in accordance with Local and/or National Electric Codes.

INSTALLATION (CONT'D)

Power wiring may enter the Rooftop Unit through the through the unit base and roof curbs on all models. Install conduit connectors at the entrance locations. External connectors must be weatherproof.

Grounding

All units must be properly grounded. The ground lug is provided for this purpose. **DO NOT** use the ground lug for connecting a neutral conductor. The unit must be electrically grounded in accordance with local codes, or in the absence of local codes, with the NEC ANSI/NFPA 70 1981.

Once it is established that supply voltage is within the utilization range, check and calculate if an unbalanced condition exists between phases. Calculate percent voltage unbalance as follows:

Percent Voltage = 100X Unbalance	$\frac{\text{Maximum Voltage DeviationFrom Average Voltage}}{\text{Average Voltage}}$
<p>EXAMPLE — With voltage of 220, 215 and 210 Average voltage = $220 + 215 + 210$ $= 645 \div 3 = 215$ Maximum voltage deviation from Average voltage = $220 - 215 = 5$</p> <p style="text-align: center;">Percent Voltage = $\frac{100 \times 5}{215} = \frac{500}{215} = 2.3\%$</p> <p>Percent voltage unbalance must not exceed (2%) two percent</p>	

Contact power company if phase unbalance exceeds 2%.

Control System Wiring: For commercial equipment the following table lists the minimum size of 24 volt class 2 wire to be used.

WIRE SIZE	FT. RUN FROM UNIT TO THERMOSTAT OR LONGEST RUN
18 AWG	Maximum Run 50 Feet
16AWG	Maximum Run 75 Feet
14AWG	Maximum Run 100/125 Feet
12AWG	Maximum Run 150/200 Feet

Note: Wiring - Consult the wiring diagram furnished with the unit. These units are custom designed for each application. The unit wiring diagram is located inside the control panel of each unit.

Ductwork

Properly sized and installed ductwork is critical to reliable performance of the unit and system. The TRS Series is down flow (vertical), horizontal supply and 100% outside air or horizontal supply and return duct connections with the use of a tall horizontal duct curb. All duct connections with the use of a curb are to be field sized and cut. All ductwork must be installed according to local codes, practices and requirements.

Industry manuals should be used as a guide to sizing and designing the duct system. Ducts passing through unconditioned spaces must be well insulated with vapor barrier to prevent condensation.

Condensate Piping

A condensate trap must be provided by customer. Drainage of condensate directly onto the roof is acceptable if permitted by local codes. It is recommended that a small drip pad of either stone, or tar, wood or metal be provided to prevent any possible damage to the roof. If condensate is to be piped into the building drainage system, the drain line must penetrate the roof external to the unit. Refer to local codes for additional requirements.

INSTALLATION (CONT'D)

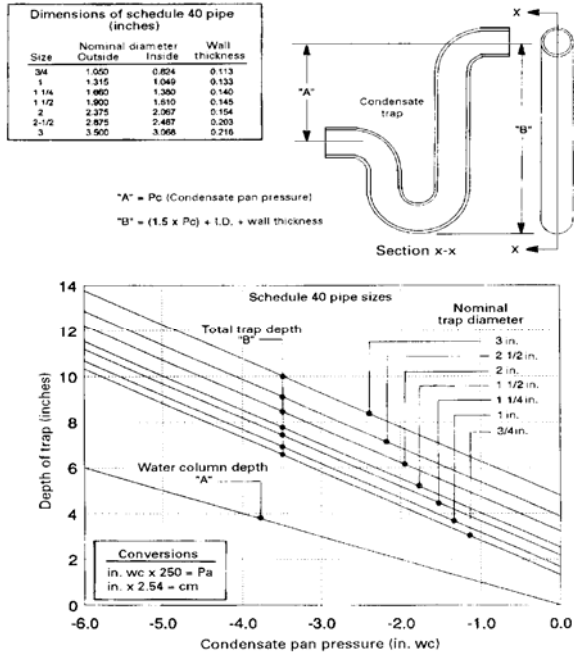

THE TRAP MUST BE PRIMED BEFORE OPERATING UNIT.

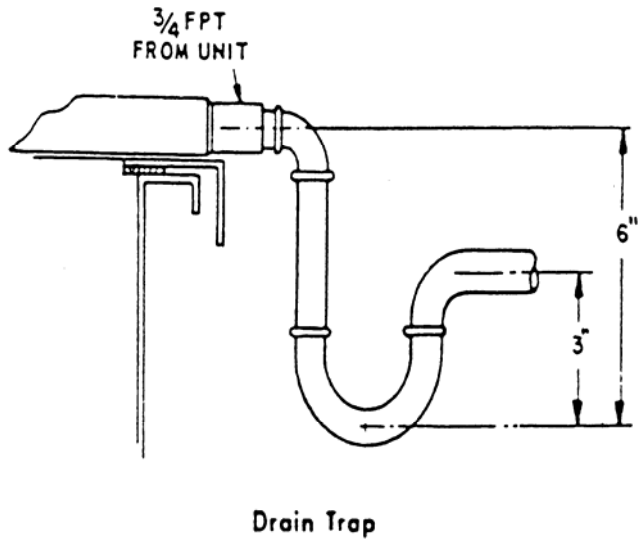

Figure 2

CAUTION: Units with high internal and external static pressure drops will require a deeper trap. Use the graph and table in Figure 2.

WARNING

GAS PIPING AND VENTING

For TRS units with gas furnace options locate the gas furnace instruction manual located inside each unit control vestibule. **This manual will provide you with specific installation requirements and important safety and warning information that must be reviewed prior to installation of the gas heating equipment.**

Gas-fired appliances are not designed for use in hazardous atmospheres containing flammable vapors or combustible dust, in atmospheres containing chlorinated or halogenated hydrocarbons, or in applications with airborne silicone substances. Improper installation, adjustment alteration, service, or maintenance can cause property damage, injury, or death. Read the installation, operation, and maintenance instructions thoroughly before installing or servicing this equipment.

WARNING

FOR YOUR SAFETY

The use and storage of gasoline or other flammable vapors and liquids in open containers in the vicinity of this appliance is hazardous.

INSTALLATION (CONT'D)

Clearances

Adequate clearance around the unit must be kept for safety, accessibility, service, and maintenance. 48 inches clearance is required on the side (furnace and electrical) end of the unit. This clearance must be maintained for compressor removal and up to 64 inches in the case of a furnace or ECW wheel unit.

All combustibile materials must be kept out of the area. A 48 inch clearance is also required on the front (outside air) end of the unit for blower removal and for adequate outside air accessibility. The clearance of 64 inches on the filter access side of the unit is required for ECW wheel removal if installed. A clearance of 36 inches is required on the condenser side for an adequate supply of condenser air.

Accessibility, Service and Maintenance Clearances

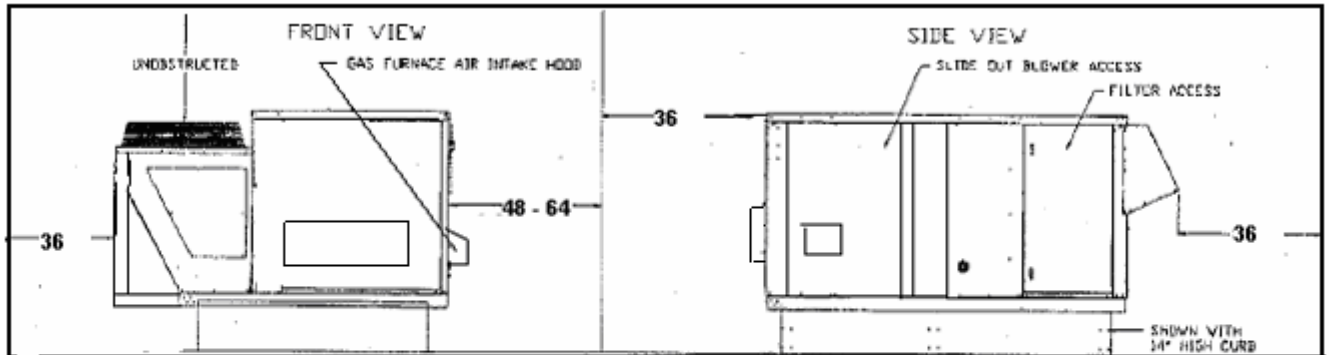

WARNING! IMPORTANT NOTE: No windows, doors, exhaust or intake air opening maybe located in front of the gas furnace flue outlet. To do so exposes the building occupants to the DANGER of carbon monoxide poisoning! This could result in severe personal injury or death.

Combustion Air Clearances

Model	REQUIRED CLEARANCES				
	Top	Sides*		Bottom	
		Control	Opposite	To Combustibles	To Non-Combustibles
TRS Series	36"	Width Of Furnace Plus 6"	0"	24"	0"
*Provide clearance as shown for safety, for combustion, and for service.					

COOLING SYSTEM OPTIONS

Hot Gas Bypass

Hot gas bypass is a means of capacity control during lower ambient temperature conditions. The Hot Gas Bypass valve is an adjustable valve and should be set to open when the refrigerant suction pressure drops to 107-112 psig. It varies unit capacity by introducing discharge refrigerant into the evaporator circuit where it creates a false evaporator load. The hot gas is cooled prior to its return to the compressor as it passes through the evaporator.

The Hot Gas Bypass Solenoid Valve is energized through the thermostat and routes discharge gas to the hot gas bypass valve. It is de-energized during the pump down cycle.

COOLING SYSTEM OPTIONS (CONT'D)

Head Pressure Control

Low ambient control. Cycling the condenser fan or fans in response to compressor discharge pressure will permit stable operation in ambients down to 32F. The operating pressure switch is adjustable to match customer needs; it is factory set to re-energize the fans when discharge pressure drops to 295 psig and energize them when pressure increases to 410 psig.

Variable Speed Control

The **VARISPEED™** Fan Control System controls the compressor discharge pressure. The speed control module responds to discharge pressure; it speeds the condenser fan up as pressure rises and slows the fan down as pressure falls due to load conditions or as outdoor ambient temperature falls.

Head pressure control is accomplished with one or two variable speed condenser fan drives and controller, factory set to begin fan rotation at 311 psig and be at full fan speed at 410 psig.

Dual compressor, dual fan units have one variable speed motor and controller on each circuit.

Single or tandem compressor, four fan units have one variable speed motor and control and three 3 phase constant speed motors. Two adjustable pressure controls are used on the 3 fans, the first operating one fan between 443 psig and 358 psig, the second operating two fans between 460 psig and 375 psig.

CAUTION: Pressure settings on the constant speed fans must **NOT** be set so as to permit operation below 358 psig or the variable speed motor may stall and overheat.

Single compressor, single fan units will have one variable speed motor and control.

At low ambient, the variable speed fan operates, increasing in speed until maximum RPM is achieved at or around 45°F ambient. An adjustable pressure switch operates the constant speed three-phase fan set to energize the motor at 443 psig and de-energize at 358 psig. In the ambient temperature span of approximately 50°F to 53°F, the variable speed fan will ramp between maximum and minimum speed while the constant speed fan cycles. The start-stop cycle varies from 45 seconds to 2½ minutes during this period.

At 53°F, both fans are operating; the variable speed at minimum RPM and the constant speed at full RPM. As the ambient continues to rise, the variable speed motor increases to full speed and remains there.

If the application calls for a closer setting between maximum and minimum pressure settings on the constant speed fan, for example 443 psig on, 388 psig off, the effect will be to lengthen the temperature span during which the cycling takes place, for example 50°F to 57°F.

Adjustable High and Low Pressure Switches

Standard cooling units are equipped with non-adjustable pressure switches. The low pressure switch is set to open at 135± psig and is an automatic reset switch closing at 99± psig. The high pressure switch is set to open at 640± psig and is a manual reset switch set to close at 595± psig.

Units can be equipped with adjustable high and low pressure switches for those installations that require finer settings than the non-adjustable switches provide. Low pressure switches have both set point and differential adjustments and are automatic reset. High pressure switches must not be set above 640 psig and are manual reset. Set point and differential are adjustable.

MECHANICAL ADJUSTMENTS

SET FAN RPM.

All evaporator motor sheaves are set when tested and shipped from the factory. Actual rpm must be set and verified with a tachometer. Refer to the following Blower Performance Chart for basic unit fan rpm.

With disconnect switch open, place a jumper wire across Terminals R and G at TS1 Terminal Block. Close disconnect switch; evaporator fan motor will operate so rpm can be checked.

FAN ROTATION CHECK

Check that fan rotates clockwise when viewed from the drive side of unit and in accordance with rotation arrow shown on blower housing. If it does not, reverse two incoming power cables at TB Terminal Block.

Do not attempt to change load side wiring. Internal wiring assures all motors will rotate in correct direction once evaporator fan motor rotation check has been made.

MECHANICAL ADJUSTMENTS (CONT'D)

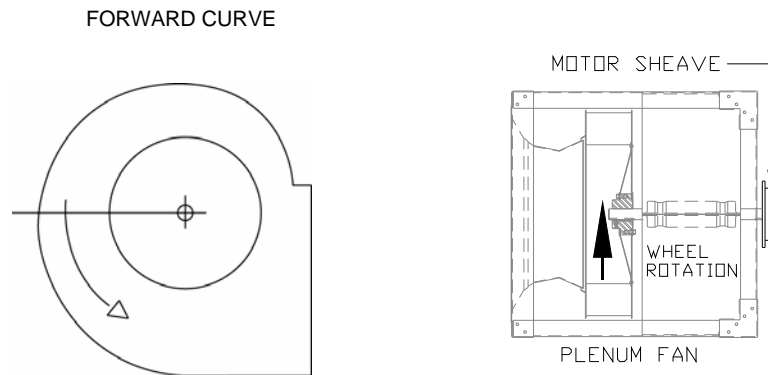

Figure 4

Blower Rotation

DRIVE BELT TENSION AND ALIGNMENT

For ease of service the TRS model unit is equipped with a slide out fan assembly. Two screws must be removed and the wire harness wire tie must be cut to allow the fan to slide forward.

WARNING: The fan can slide completely out of the cabinet so us extreme care not to slide fan out to a point where the fan could fall out of the cabinet causing severe personal injury and or equipment and roof damage. Leave at least 12 inches of the fan slide flanges engaged to the blower box rails to allow for proper support of the fan. Never apply additional weight or stand on the blower as a step!

Fan belt alignment and tension should be checked. Tension should be 3/4" depression per foot of belt span between pulleys.

Personal injury hazard. Use extreme care during the following procedures and obey Safety Information.

Failure to do so may result in personal Injury.

The following safety rules MUST always be followed when working near belt drive.

Always Turn The Power Off

1. Turn the power to the unit OFF before you begin working on it.

Always Wear Protective Clothing

2. **NEVER** wear loose or bulky clothes, such as neckties, exposed shirttails, loose sleeves, or lab coats around belt drives. Wear gloves while inspecting sheaves to avoid nicks, burrs, or sharply worn pulley edges.

The blower speed is changed by adjusting the variable speed pulley mounted on the blower motor.

If the blower speed needed is different than the speed of the blower as shipped, follow the steps below to change the blower speed. Before changing the blower speed, read the above safety rules first.

3. Turn electric power **OFF**.
4. Remove the side blower access panel. Loosen the four motor mount bolts
5. Turn the motor adjustment bolt counterclockwise until the belt is slack enough to come off easily.
6. Remove the belt. Do **NOT** pry off belt.
7. Loosen set screw(s) on the outer half of the adjustable pulley.
8. The unit has one of two different types of adjustable pulleys.
9. Remove key if unit has a keyway type pulley.
10. To set the blower for a desired CFM (L/s), first turn the outer half of the adjustable pulley clockwise until it meets the inner half of the pulley.

MECHANICAL ADJUSTMENTS (CONT'D)

11. Turn the outer half of the adjustable pulley counter clockwise the correct number of turns to obtain the desired CFM (L/s).

NOTE: To increase the blower speed, turn the outer half of the adjustable pulley clockwise. To decrease the blower speed, turn the outer half of the adjustable pulley counter clockwise.

12. Replace key if unit has keyway type pulley.

13. Tighten set screw(s).

14. Put on belt.

15. Turn motor adjustment bolt clockwise until the belt has enough tension at the proper deflection. Use one of the commercially available belt tension gauges to set the correct tension at the proper deflection.

16. Use a straight edge (angle iron, straight piece of board or anything with a straight surface or edge) to check the alignment of the blower pulley with blower motor pulley.

18. It may be necessary to back the tension off the belt temporarily and tighten one of the motor mount bolts before it is possible to adjust the angle of the blower motor.

19. Tighten all four blower motor mount bolt

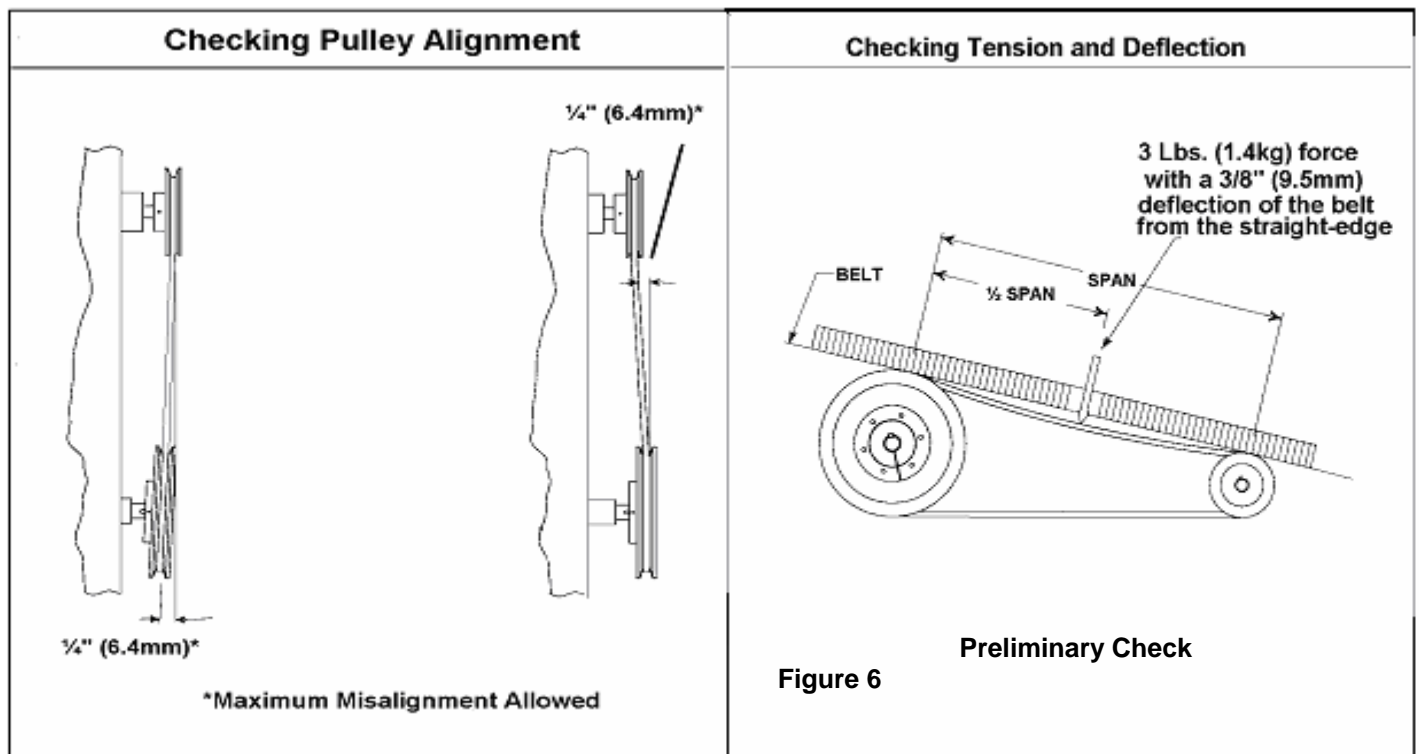

ELECTRICAL SYSTEM OPTIONS

Airflow Switch. Designed to prevent system operation unless there is proof of blower operation. A differential pressure switch measures the air pressures at the suction and discharge of the blower.

Clogged Filter Indicator. Dirty or clogged filters are indicated when the preset pressure differential across the filters is reached. The indicator is factory installed and is manually reset. It includes contacts for remote indication.

Convenience Outlet. (Field Wired) A 115V GFCI receptacle mounted in a 2"x4" enclosure and is furnished with a 15 amp circuit breaker. Separate 115-volt power source and ground is required.

ELECTRICAL SYSTEM OPTIONS (CONT'D)

Convenience Outlet. (Factory Wired) A 115V GFCI receptacle mounted in a 2"x4" enclosure may be furnished with a 15 amp circuit breaker, disconnect and 1500 Watt transformer. The transformer will be field connected to the line side of the unit disconnect switch.

Exhaust Fan Interlock. A relay installed in the unit control panel is energized when the blower is energized to interlock the unit with building exhaust fan(s).

Power Through the Curb. A chase is installed in the curb, directly under the electrical control section to bring power wiring inside the curb, preventing a separate roof penetration. The sleeve must be sealed after wiring is completed with suitable mastic to prevent water from entering the space.

Firestat. This control, mounted in the return air section, de-energizes the unit when return air reaches 135°F. The firestat is a manual reset control.

Sure-Trip™. This control automatically stops the unit whenever a phase is lost, when phases are out of sequence, or when supply voltage drops too low. Restart is automatic with a 5-minute delay after proper power supply conditions are restored.

Unit Controller A multi-function PLC controller is installed, in which complete unit operation is established through inputs of temperature, pressure, humidity sensors as well as other analog and digital inputs. The controller will provide a complete operating and monitoring system.

SEQUENCE OF OPERATION (HEATING)

Heating, Hydronic or Steam

Both hydronic and steam heat require a one or two row coil generally located downstream of the evaporator coil.

Controls for hydronic heat will involve a 3 way motorized mixing or blending valve, driven by a signal from a leaving air temperature thermostat.

Controls for low-pressure steam heat contain a motorized throttling valve driven by a signal from a leaving air temperature thermostat

Heating, Electric Resistance

1. Three-phase power to the unit distribution block energizes 24-volt circuit in transformer T.
2. Indoor blower motor contactor is energized through normally closed contact of heat relay, stage 1, HR1, completing circuit from C to D.
3. A call for first stage heat closes circuit W1 and C, energizing HR1.
4. Heating contactor No. 1, HC1 is energized through closed air pressure differential switch APS, if used; closed high limit switches AR1 and AR2 and closed HR1 contact.
5. A call for second stage heat closes circuit W2 and C, energizing heat relay stage 2, HR2.
6. Closed HR2 contact energizes Heating Contactor No. 2, HC2.
7. Fusing and high limit switches protect the unit from malfunction.

Heating, Gas

See the Gas Furnace instructions for gas furnace wiring and performance data. Additional information can be found on the furnace access door such as the rating and serial label, wiring and lighting instruction label.

The furnace section is made from the control terminal across the N.C. contacts of the combustion pressure switch, energizing pilot ignition time delay relay heater. After delay of approximately 30-50 seconds the time delay relay's switch closes energizing the furnace Venter motor. As the Venter operates, it causes the combustion pressure switch to open. The ignition control energizes a high voltage electric spark, and the pilot valve solenoid in the combination gas valve.

The flame sensor proves the presence of the pilot flame generating a DC current of 0.2 micro-amp (or greater) to the ignition control. The ignition control's internal switch action then de-energizes the spark transformer and makes a circuit to the high fire solenoid of the combination gas valve.

When there is a call for gas furnace operation the discharge air temperature causes a change in the resistance of a discharge air sensor thermistor. The Maxitrol solid state control center measures the sensor's change in resistance and sends a varying DC current to the Modulator-Regulator valve to adjust the gas input as required.

Startup and Operation

WARNING

WARNINGS OF POTENTIAL HAZARDS

1. **DANGER:** Failure to comply will result in severe personal injury or death and/or property damage.
2. **WARNING:** Failure to comply could result in severe personal injury or death and/or property damage.
3. **CAUTION:** Failure to comply could result in minor personal injury and/or property damage.

1. Installation Codes

The duct furnaces covered in this manual are design-certified by Intertek Testing Services (ETL) and are approved for use in the United States and Canada for use with natural or propane gas. See the "RATINGS AND SERIAL INFORMATION" label located on the inside of the vestibule access door for the type of gas, correct firing rate and electrical characteristics your furnace is equipped for.

In the United States, these furnaces must be installed in accordance with the standard of the National Fire Protection Association (NFPA) or the National Fuel Gas Code ANSI Z223.1a (latest edition). The National Fuel Gas Code is available from the American Gas Association, 1515 Wilson Boulevard, Arlington, VA. 22209. NFPA Publications are available from the National Fire Protection Association, Batterymarch Park, Quincy, MA 02269.

In Canada, installations must be in accordance with the CAN/CGA B149.1 and B149.2 Installation Code for Gas Burning Appliances and Equipment. Canadian Codes are available from the Standards Department, Canadian Gas Association, 55 Scarsdale Road, Don Mills, Ontario M3B-2R3.

Local authorities having jurisdiction should be consulted before installations are made to verify local codes and installation procedures.

WARNING: To ensure safety, follow the instructions provided on the "LIGHTING INSTRUCTIONS" label located on the inside of the vestibule access door and on page 15 of this instruction manual.

WARNING: Read ALL instructions to prevent personal injury or death.

WARNING: This manual is for use only by a qualified heating installer/service technician.

WARNING: Do not block flow of supply, combustion or ventilation air to the furnace. Should overheating occur or gas supply fail to shut off, DO NOT TURN OFF OR DISCONNECT ELECTRICAL SUPPLY to inducer fan. Instead, SHUT OFF THE GAS SUPPLY at a location external to the appliance.

WARNING: To avoid electric shock disconnect all electrical supply before installing or performing maintenance.

WARNING: If any of the original factory installed wiring must be replaced it must be replaced with copper wire of the same gauge and insulation rated for a minimum of 105°C.

CAUTION: To avoid potentially severe burns, allow furnace to cool before performing maintenance.

2. Chlorines and Harsh Environments

The presence of chlorine vapors in the combustion air of gas-fired heating equipment presents a potential corrosion hazard. Chlorine will, when exposed to flame, precipitate from the compound, usually Freon or degreaser vapors, and go into solution with any condensation that is present in the heat exchanger or associated parts. The result is hydrochloric acid which readily attacks all metals including 409 and 439 stainless steels. Care should be taken to separate these vapors from the combustion process. This may be done by wise location of the furnace with regard to exhausters or prevailing wind direction. Remember, chlorine is heavier than air. This fact should be kept in mind when determining installation locations of heating equipment and building exhaust systems.

GAS FURNACE (CONT'D)

3. Gas Piping (Individual or Multiple Furnace Applications)

All piping must be in accordance with the National Fuel Gas Code ANSI Z223.1a (latest edition), published by the American Gas Association or CAN/CGA-B149.1 and B149.2 (latest edition), published by the Canadian Gas Association. Always refer to local codes where required. Open the vestibule access door. Select the proper gas pipe clearance hole pre-installed in the furnace cabinet in three places depending on the best location for the field gas line. This may require moving the pipe grommet from its factory installed position to the desired location as well as moving the cap to the old location of the pipe grommet to ensure rain water will not get inside the furnace vestibule. All model DF duct furnace use $\frac{3}{4}$ " NPT gas connections to the gas valve. **See Table 1** for proper pipe diameter for the length and Btu input.

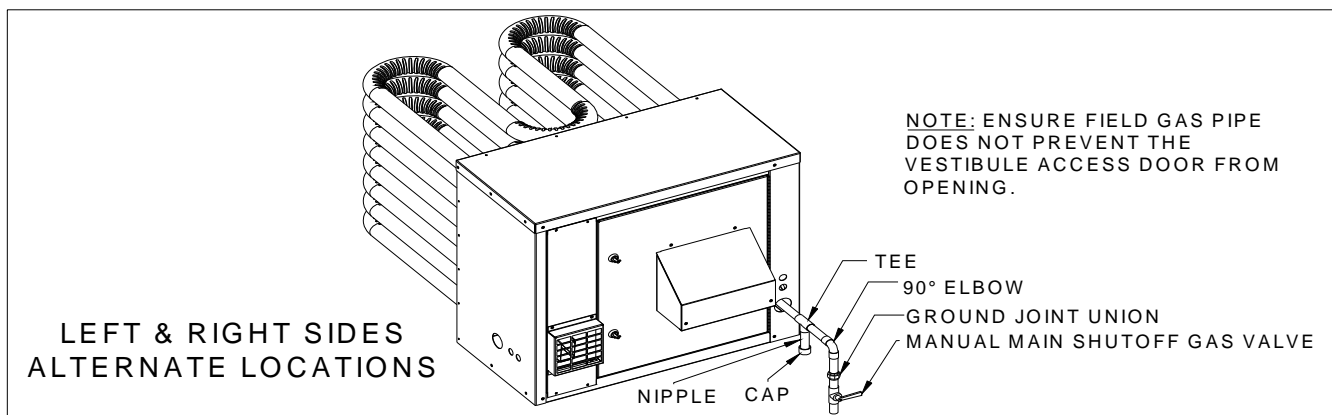

Support piping with hangers, not by the furnace. Purge all air from the gas supply piping. Before placing the duct furnace into operation, check the furnace and its gas connections for leaks.

NOTICE: Close manual main shutoff valve during any pressure testing at less than 13 IN. WC. The gas valve is equipped with two $\frac{1}{8}$ " NPT taps for gas pressure measurements.

Disconnect furnace and gas valve from gas supply piping during any pressure testing greater than 13 IN. WC. Installer must add a $\frac{1}{8}$ " minimum NPT fitting in this case.

WARNING: DO NOT CHECK FOR GAS LEAKS WITH AN OPEN FLAME. Use a bubble test. Failure to use a bubble test or check for leaks can cause severe personal injury, death or substantial property damage.

Use pipe sealing compound compatible with propane gases. Apply sparingly only to male threads of pipe joints so that pipe sealing compound does not block gas flow.

WARNING: Failure to apply pipe sealing compound as detailed above can result in severe personal injury, death or substantial property damage.

NATURAL GAS:

Refer to **Table 1** for pipe length and diameter. Base on maximum rated furnace input (divide by 1,000 to obtain cubic feet per hour). **Table 1** is only for gas with specific gravity 0.60, with a pressure drop through the gas piping of 0.30 IN. WC. For additional gas pipe sizing information, refer to ANSI Z223.1 for installations in the United States or for Canadian installations refer to CAN/CGA B149.1 or B149.2.

Natural Gas Required Pressures:

- Maximum: 13 IN. WC
- Minimum: 5 IN. WC
- Manifold gas pressure: 3.5 IN. WC

GAS FURNACE (CONT'D)

PROPANE GAS:

Contact the gas supplier to size pipes, tanks and 100% lockup gas pressure regulator. Adjust propane regulator provided by the gas supplier for 13 IN. WC maximum pressure.

Propane Gas Required Pressures:

- Maximum: 13 IN. WC
- Minimum: 11 IN. WC
- Manifold gas pressure: 10 IN. WC

(Table #1)

Gas pipe length (feet)	Natural Gas (1000 BTU/Cubic Feet) Capacity of pipe for pipe size of: (Capacity in cubic feet gas per hour) Pipe capacity for 0.60 specific gravity					Propane Gas (2550 BTU/Cubic Feet) Capacity of pipe for pipe size of: (Capacity in cubic feet gas per hour) Pipe capacity for 1.60 specific gravity				
	3/4"	1"	1-1/4"	1-1/2"	2"	3/4"	1"	1-1/4"	1-1/2"	2"
10	278	520	1050	1600	2700	122	228	465	687	1304
20	190	350	730	1100	2100	116	214	445	671	1281
30	152	285	590	890	1650	93	174	360	543	1007
40	130	245	500	760	1450	79	149	305	464	885
50	115	215	440	670	1270	70	131	268	409	775
60	105	195	400	610	1105	64	119	244	372	674
70	96	180	370	560	1050	59	110	226	342	641
90	84	160	320	490	930	51	98	195	299	567
100	79	150	305	460	870	48	92	186	281	531
125	72	130	275	410	780	44	79	168	250	476
150	64	120	250	380	710	39	73	153	232	433
175	59	110	225	350	650	36	67	137	214	397
200	55	100	210	320	610	34	61	128	195	372

GAS HEAT (CONT'D)

4a Operation – Lighting instructions

WARNING: To ensure safety, follow the instructions provided on the “LIGHTING INSTRUCTIONS” label located inside of the vestibule access door and on this page.

FOR YOUR SAFETY READ BEFORE LIGHTING

WARNING: If you do not follow these instructions exactly, a fire or explosion may result causing property damage, personal injury or loss of life.

- A. This appliance is equipped with an ignition device which automatically lights the burner. Do not try to light the pilot by hand.
- B. BEFORE OPERATING smell all around the appliance area for gas. Be sure to smell next to the floor because some gas is heavier than air and will settle on the floor.
- WHAT TO DO IF YOU SMELL GAS
- Do not try to light any appliance.
 - Do not touch any electric switch; do not use any phone in your building.
 - Immediately call your gas supplier from a neighbor's phone. Follow the gas supplier's instructions.
 - If you cannot reach your gas supplier, call the fire department.
- C. Use only your hand to turn the gas control knob. Never use tools. If the knob will not turn by hand, don't try to repair it, call a qualified service technician. Force or attempt repair may result in a fire or explosion.
- D. Do not use this appliance if any part has been under water. Immediately call a qualified service technician to inspect the appliance and to replace any part of the control system and any gas control which has been under water.

LIGHTING INSTRUCTION

1. STOP! Read the safety information above on this label
2. Set the thermostat to lowest setting.
3. Turn off all electric power to the appliance.
4. This appliance is equipped with an ignition device which automatically lights the burner. Do not try to light the burner by hand.
5. Open the control access door.
6. Turn the gas control knob clockwise ↻ to "OFF".
7. Wait five (5) minutes to clear out any gas. Then smell for gas, including near the floor. If you smell gas, STOP! Follow "B" in the safety information above on this label. If you don't smell gas go to the next step.
8. Turn gas control knob counterclockwise ↻ to "ON"
9. Close the control access door.
10. Turn on all electric power to the appliance.
11. Set thermostat to desired setting.
12. If the appliance will not operate, follow the instructions "To Turn Off Gas To Appliance" and call your service technician or gas supplier.

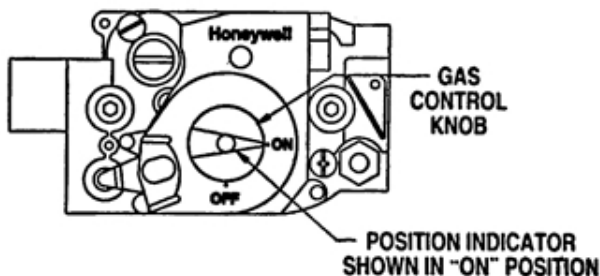

TO TURN OFF GAS TO APPLIANCE

1. Set the thermostat to lowest setting.
2. Turn off all electric power to the appliance if service is to be performed.
3. Open the control access door.
4. Push in gas control knob slightly and turn clockwise ↻ to "OFF". Do not force.
5. Close the control access door.

0527P-1394

GAS HEAT (CONT'D)

1. **Read Lighting Instructions** on page 15.
2. **Raise** space thermostat to call for heat.
3. **Inducer motor energizes.** After pressure switch proves proper airflow, control module initiates a 30-second purge.
4. **Control module sparks** the direct spark igniter and opens main gas valve.
 - a. If main **burners do not light** within 4 seconds, the main gas valve is closed and the spark igniter turned off. The ignition control initiates a 30 second post-purge, then starts a new cycle.
 - b. If main **burner does light** and control module senses flame current, spark igniter is turned off and burners stay on until space temperature satisfies the thermostat.
5. During main burner operation:
 - a. The ignition control monitors main burner flame current. If signal is lost, the spark igniter is energized and sequence returns to step 4.
 - b. If power is interrupted, control system shuts off main gas valve and restarts at step 2 when power is restored.
6. In the event the supply air limit control shuts down the furnace during operation, the control module closes the main gas valve, but keep the inducer energized for 30 seconds post-purge.
7. **Lower** space thermostat setting to stop call for heat. Thermostat is satisfied – Main gas valve is closed inducer is turned off.
8. Furnace is now in the **off cycle**.
9. **Repeat steps 1 through 7 several times to verify correct furnace operation.**
10. Return the space thermostat to normal setting.
11. If so equipped, set thermostat heat anticipator setting to 0.4 amps, adjusted for gas valve and control current.

LED Status	Code Description
Steady On	Good Control-Normal Operation
1 Flash	Open Position Pressure Switch
2 Flashes	Stuck Closed Position Pressure Switch
3 Flashes	Failed Ignition
4 Flashes	Too Many Flame Losses
5 Flashes	Internal Ignition Control Fault
6 Flashes	Too Many Pressure Switch Losses

GAS HEAT (CONT'D)

4b Operation wiring diagrams

Figure 3A - 2 Stage Control System Connection Wiring Diagram

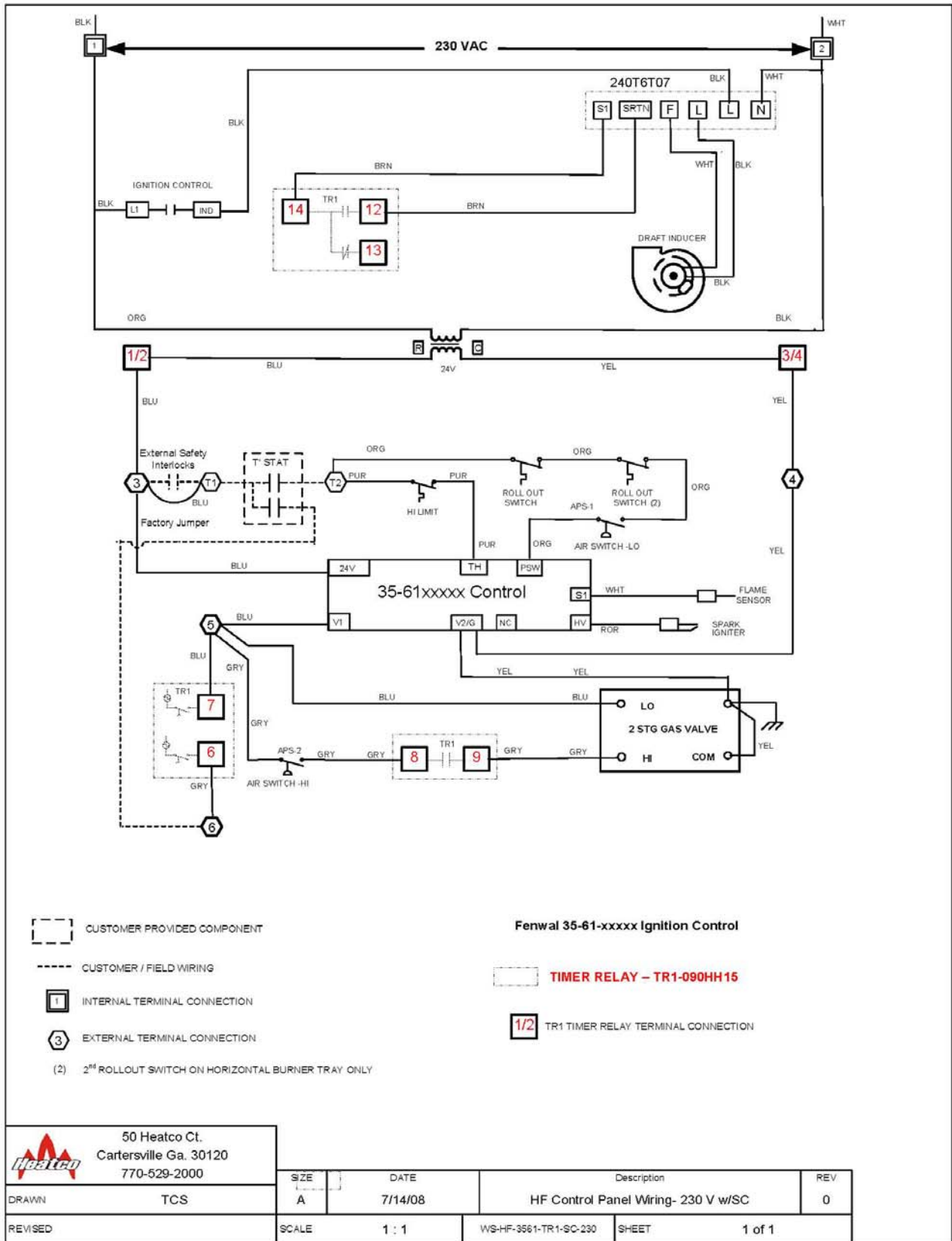

GAS HEAT (CONT'D)

HF - Sequence of Operation – Two Stage Operation with Speed Controller



HF- Sequence of Operation – Two Stage Operation with Speed Controller

Fenwal 35-61 Series Direct Ignition Control w/ TR1 Timer Relay Control

When system is powered up 24 VAC will be applied to the ignition control (IC) terminals 24VAC / R and to the Timer Relay Control (TR1). The ignition control will reset, perform a self check routine, initiate full time flame sensing, flash the diagnostic LED for up to four seconds and enter the thermostat scan standby state. The amber light on the TR1 will be lit indicating it is in the ready position.

Call for Heat

1. Thermostat (controller) (1st stage or 1st and 2nd stage) closes on call for heat.
2. 24 VAC to is supplied to IC terminal TH, provided limit switch is in closed position.
3. The control will check that pressure switch contacts are open (IC terminal PSW is not powered).
4. Combustion blower is then energized at high speed.
5. When the Air Switch (APS1) closes, a 15 second pre-purge period begins.
6. At end of pre-purge period, the spark commences and the 1st and 2nd stage gas valves are energized for the trial for ignition period.
7. Burners ignite and cross light, operating at maximum input rate (Manifold pressure 3.5" w.c.).
8. TR1 is powered (terminal 7) simultaneously (SR LED lit) and begins timing a 90 second warm-up period while maintaining the combustion blower at high speed (FR LED lit). The TR1 will maintain this mode of operation, regardless of status of thermostat 2nd stage.
9. When flame is detected by flame sensor, the spark is shut-off immediately and gas valves and combustion blower remain energized.
10. When the initial timer in TR1 times out, it defaults the gas valve to low fire and the combustion blower to low speed and returns control of the operating mode to the temperature controller. The SR LED turns off and the MR LED is lit.
11. If the controller is calling for 2nd stage heat TR1 terminal 6 is powered. After a short time delay (approximately 15 seconds), the system switches the combustion blower to high speed (FR LED lit) and the 2nd stage gas valve @ 3.5" w.c. manifold pressure (CR LED lit), provided the High Air Pressure Switch (APS2) is proved.
12. During heating operation, the thermostat, pressure switch and main burner flame are constantly monitored by the IC to assure proper system operation.
13. Operation continues on High fire until the 2nd stage thermostat is satisfied, opening the 2nd stage contact and de-energizes terminal 6 on the TR1, turning off the 2nd stage gas valve and returning the combustion blower to low speed.
14. When the thermostat (controller) is satisfied and the demand for heat ends, the 1st stage valve is de-energized immediately, the control senses loss of flame and a 30 second post-purge occurs (at high speed) before de-energizing the combustion blower.

Ignition and Operational failures during a call for heat result in "lockout" of the ignition control.

1. If flame is lost during an operational cycle, the control will respond within 0.8 seconds. The spark will be energized for a trial for ignition period to attempt to relight burners and prove flame sensor. If flame is re-established, normal operation resumes.
2. If the burners fail to light or carryover during a trial for ignition, the control will attempt two additional ignition trials. If no flame is present at the flame sensor within 10 seconds, the spark and gas valve will be de-energized. A 15 second inter-purge period begins and the combustion blower continues to run. After the inter-purge period another ignition trial will take place.
3. If burner fails to light or prove the flame sensor following the two additional trials the control will go into lockout. The valve relay in the IC will be de-energized shutting of the gas valve immediately and the combustion blower following a 30 second post-purge period.

Recovery from Lockout

1. If the thermostat (controller) is still calling for heat one hour after a lockout occurs, the control will automatically reset and initiate a call for heat sequence.
2. The ignition control may also be manually reset, by turning the thermostat (controller) down and back up to previous temperature setting or removing power (24V) to IC terminal 24VAC.

Fault Conditions and LED Key

LED Steady On	Internal Control Fault
1 Flash	Combustion Air Flow Fault
2 Flash	Flame with No Call for Heat
3 Flash	Ignition Lockout

LED flashes on for ¼ second, and off for ¼ second during fault condition. Pause between fault codes is 3 seconds

1. If during the initial call for heat the air switch contacts are closed for 30 seconds without an output to the combustion blower, an airflow fault occurs (one LED flash) and control will remain in this mode.
2. If the air flow switch remains open (or a rollout switch is open) for more than 30 seconds after the combustion blower output (IND) is energized, an air flow fault occurs (one LED flash), and control will stay in this mode with combustion blower on, waiting for air flow switch (or rollout) to close.
3. If the airflow signal is lost during operation, the control immediately de-energizes the gas valve and maintains blower operation. If the call for heat remains and proper airflow is not detected, and air flow fault occurs (one LED flash). If proper airflow is detected at any time, the normal sequence will begin with pre-purge.
4. If the main valve fails to close properly at the end of a heating cycle and a flame is maintained, the combustion blower will continue in operation. If the valve does close completely later removing the flame signal, the blower will run for the post purge period and shut-off.

GAS HEAT (CONT'D)

4e Operation wiring diagrams – Continued

Figure 4A - 25 to 100% Modulation Control System Connection Wiring Diagram

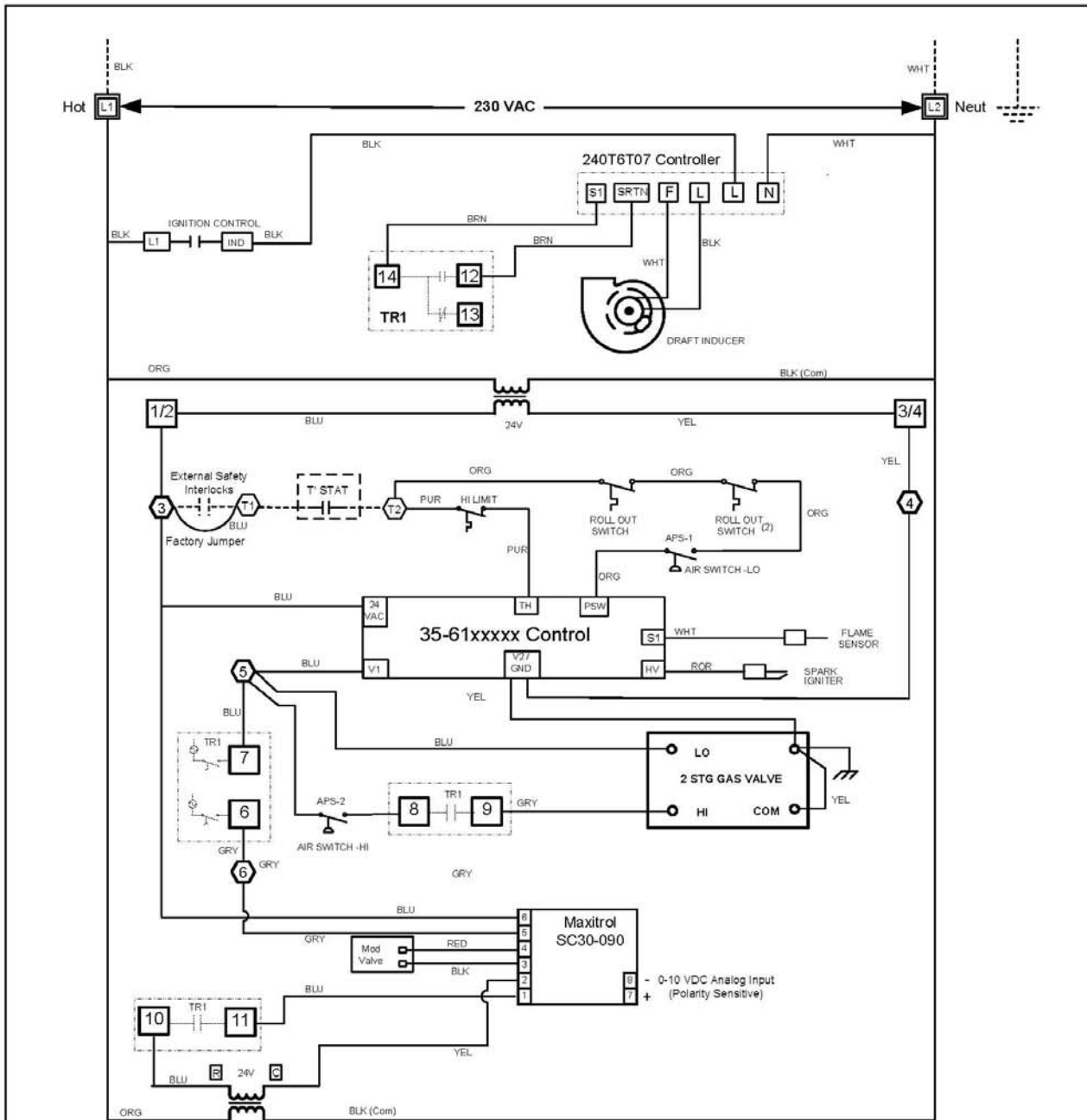

CUSTOMER PROVIDED COMPONENT

EXTERNAL TERMINAL CONNECTION

TIMER RELAY – TR1-090LH15

CUSTOMER / FIELD WIRING

TR1 TERMINAL CONNECTION

Fenwal 35-61-xxxxx Ignition Control

INTERNAL TERMINAL CONNECTION

(2) 2nd ROLLOUT SWITCH ON HORIZONTAL BURNER TRAY ONLY

50 Heatco Ct.
Cartersville Ga. 30120
770-529-2000

SIZE	DATE	Description	REV
A	7/11/08	* MD* Control Panel Wiring – 230V w/ SC	0
SCALE	1 : 1	WS-MD-3561-TR1-SC-230	SHEET 1 of 1

MD - Sequence of Operation –Electronic Modulation with Inducer Speed Control



MD- Sequence of Operation – Electronic Modulation with Inducer Speed Control

Fenwal 35-61 Series Direct Ignition Control, TR1 Timer Relay Control and SC30 Modulation Control

When system is powered up 24 VAC will be applied to the ignition control (IC) terminals 24VAC / R and to the Timer Relay Control (TR1). The ignition control will reset, perform a self check routine, initiate full time flame sensing, flash the diagnostic LED for up to four seconds and enter the thermostat scan standby state. The amber light on the TR1 will be lit indicating it is in the ready position.

Call for Heat

1. Thermostat (heat enable) closes on call for heat.
2. 24 VAC to is supplied to IC terminal TH, provided limit switch is in closed position.
3. The control will check that pressure switch contacts are open (IC terminal PSW is not powered).
4. Combustion blower is then energized at high speed.
5. When the Air Switch (APS1) closes, a 15 second pre-purge period begins.
6. At end of pre-purge period, the spark commences and the 1st stage gas valve is energized for the trial for ignition period.
7. TR1 is powered (terminal 7) simultaneously (SR LED lit) and begins timing a 90 second warm-up period while maintaining the combustion blower at high speed (FR LED lit) and powers the SC30. The SC30 will output 12 to 13 VDC to the modulating control valve during the timing duration (90 seconds) of TR1, regardless of the analog input signal to SC30 terminals 7 & 8.
8. Burners ignite and cross light, operating at the adjusted mid-fire input rate (Manifold pressure set at 1.2" to 1.5" w.c.).
9. When flame is detected by flame sensor, the spark is shut-off immediately and gas valve(s) and combustion blower remain energized.
10. When the initial timer in TR1 times out, it defaults the gas valve to low fire and the combustion blower to low speed and returns control of the operating mode to the building temperature controller. The SR LED turns off and the MR LED is lit.
11. If the controller is providing an analog signal between 0.5 and 5.3 VDC to the SC30 control, the system will continue to run at low speed combustion blower and with only the 1st stage valve open. The modulating valve will be powered proportional to the input voltage signal from the controller, and will open or close changing the gas manifold pressure. Manifold pressure will vary from 0.3 to 1.2" w.c. operating in this mode.
12. If the signal increases above 5.3 VDC, the SC30 relay closes powering terminal 6 on the TR1, and starts a second time delay of 15 seconds. At the end of this time delay the fan switches to high speed (FR LED lit) and the 2nd stage gas valve opens (CR LED lit) through the TR1 (terminal 9) provided the High Air Switch contacts are closed. The manifold pressure will vary from 1.4 to 3.5" w.c. in this mode.
13. During heating operation, the thermostat, pressure switch and main burner flame are constantly monitored by the IC to assure proper system operation.
14. Operation continues in the High fire mode until the controller input signal to the SC30 control drops to 4.7 VDC. At this point the SC30 relay circuit opens (SC30 terminal 5 has no output) de-energizing the 2nd stage valve and the TR1 switches the combustion blower to low speed operation. Low-fire modulation will continue as in Step 11.
15. When the thermostat (temperature controller) is satisfied and the demand for heat ends, the heat enable contact opens and the 1st stage valve is de-energized immediately, the control senses loss of flame and a 30 second post-purge occurs (at high speed) before de-energizing the combustion blower.

Ignition and Operational failures during a call for heat result in "lockout" of the ignition control.

1. If flame is lost during an operational cycle, the control will respond within 0.8 seconds. The spark will be energized for a trial for ignition period to attempt to relight burners and prove flame sensor. If flame is re-established, normal operation resumes
2. If the burners fail to light or carryover during a trial for ignition, the control will attempt two additional ignition trials. If no flame is present at the flame sensor within 10 seconds, the spark and gas valve will be de-energized. A 15 second inter-purge period begins and the combustion blower continues to run. After the inter-purge period another ignition trial will take place.
3. If burner fails to light or prove the flame sensor following the two additional trials the control will go into lockout. The valve relay in the IC will be de-energized shutting of the gas valve immediately and the combustion blower following a 30 second post-purge period.

Recovery from Lockout

1. If the thermostat (controller) is still calling for heat one hour after a lockout occurs, the control will automatically reset and initiate a call for heat sequence.
2. The ignition control may also be manually reset, by turning the thermostat (controller) down and back up to previous temperature setting or removing power (24V) to IC terminal 24VAC.

IC Fault Conditions and LED Key

LED Steady On	Internal Control Fault
1 Flash	Combustion Air Flow Fault
2 Flash	Flame with No Call for Heat
3 Flash	Ignition Lockout

LED flashes on for ¼ second, and off for ¼ second during fault condition. Pause between fault codes is 3 seconds

ENERGY CONSERVATION WHEEL

Before starting up the unit, check the following:

1. Does the rotor rotate freely by hand?

If not, recheck the seal to determine whether or not it is binding and if so adjust seals following the instructions below.

2. Is the motor rotation correct?

This can be checked by detaching the belts from the drive sheave and bumping the motor. The sheave should be rotating in the direction such that the belt will result in rotation per the exterior markings. If not, rewire the motor.

3. Does the air flow orientation match up to design?

See the identification markings on the cassette and/or refer to the general arrangement drawing to check the four duct connections to the unit.

4. Are the belts on correctly and sufficiently tight?

Belt length is set by the manufacturer. Consult NovelAire if the belt appears too loose.

5. Is the VFD programmed to control the unit and to prevent frost formation?

If not, follow the instructions in the manual accompanying the VFD and/or consult NovelAire.

Seal checks

The ECW is provided with a neoprene bulb seal which provides not only an effective seal in both the peripheral and side-to-side sealing directions but also one which is easily adjusted to compensate for seal run-in, shipping misalignment, etc.

The neoprene bulb is

attached to a metal reinforced U-shaped neoprene grip. The metal/neoprene grip allows for an expandable grip range which can be moved closer or further from the sealing face as needed. The peripheral bulb seals against the wheel outer band and the inner bulb seals against the wheel face. With the wheel stopped, move seals as close to the sealing surface as possible but without exceeding grip range of bulb seal and without pressing the bulb

down against the seal face. Bump the motor. If the motor will not turn, the seal is too close and should be nudged back where needed. The seal will seek its equilibrium position based on the closest part of the sealing face. Because the seal is meant to be a non-contact seal, small gaps may be seen between seal and sealing surface once the equilibrium position is reached. Seal leakage is meant to be less than 5% at 1 inch of differential between supply and exhaust. Some seal run-in is to be expected, so don't be alarmed by small amounts of wear in the neoprene.

Variable speed drive (VFD)

Check the power supply for proper rating. Make sure that the proper jumper orientation is used for the specific control input. Make sure that the unit is programmed for proper input voltage and output voltage.

Maintenance

Bearings

Small ECW's, (smaller than ECW666) are provided with no maintenance inboard bearings. These bearings should require no maintenance during the life of the equipment. Larger ECW's come equipped with an external flanged bearing which should be greased annually. Use a petroleum based lubricant.

Drive Motor

The drive motors should require no maintenance. Replacement motors may be purchased from normal motor distributors such as Grainger, or directly from NovelAire if preferred.

Drive Belts

NovelAire ECW belts are multilink belts with individual links constructed of a high performance polyurethane elastomer reinforced with multiple plies of polyester fabric. This belt provides a strong, yet flexible, belting. The multilink feature provides quick, easy servicing or replacement. See the Appendix for belt repair/replacement instructions.

Seals

The seals are designed to be durable and require no maintenance other than adjustment, but if seals become worn or damaged they may easily be replaced. The seals are made to clip on the cassette or post metal easily. Call NovelAire for servicing information.

Wheel

The wheel is designed to last the life of the equipment. It should be protected by an ASHRAE 30% filter to keep dust and dirt from the heat transfer surface. The wheel is somewhat self cleaning through its normal action of rotating in and out of countercurrent air flow streams. If the wheel becomes dirty, it may be cleaned by blowing out the unit with compressed air (20 psig maximum). In cases of severe filthiness, the wheel may be removed from the cassette and washed with water following wheel removable procedures outlined below:

ENERGY CONSERVATION WHEEL (CONT'D)

1. Remove air handler plenum sections so that the front or back of the cassette may be easily accessed and cleared.
2. Support the wheel from the bottom.
3. If the unit is equipped with an external flanged bearing, loosen the Allen screws in the bearing housing that keeps the shaft affixed in the horizontal plane of both bearing, front and back. Remove the shaft clips at the face of the hub from both sides of the shaft. Unbolt one post completely and remove post with bearing completely out. Remove the shaft. Roll the wheel carefully out.
4. If the unit is equipped with an internal bearing, unbolt the shaft screw on both sides of the shaft. Unbolt one post completely and remove post. Remove the shaft clips at the face of the hub from both sides of the shaft. Remove the shaft. Roll the wheel out carefully
5. With the wheel out, wash the media carefully with water. Once clean, allow the media to dry out for several hours or days if necessary.
6. Reinstall using the reverse procedure. Run the unit. It may take several hours for the desiccant to dry out and for the wheel to perform normally.

TROUBLE SHOOTING GUIDES

General Refrigeration Circuit

SYMPTOM	POSSIBLE CAUSE	REMEDY
A. Compressor will not start	<ol style="list-style-type: none"> 1. Power off, loose electrical connections or fuse open. 2. Compressor contactor not closing. 3. Internal compressor thermal overload open. 4. Compressor defective. 5. High or low pressure switch open or defective. 6. Oil pressure control open or defective. 	<ol style="list-style-type: none"> 1. Check disconnect switch, fuses and wiring. Replace parts or repair as necessary. 2. Check voltage to contactor coil, transformer, slave relay, system. Replace parts as necessary. 3. If compressor is hot, allow 2 hours to cool. See thermal overload below. 4. Check compressor for electrical failure. Compressor may be seized, check for L.R.A. 5. Check calibration of high or low pressure switch, re-calibrate or replace. 6. Check oil failure control. See oil failure control below.
B. Compressor starts but cuts out on low pressure switch.	<ol style="list-style-type: none"> 1. Low refrigerant charge 2. Airflow restricted. 3. Restriction in liquid line. 4. Defective low pressure switch. 	<ol style="list-style-type: none"> 1. Check sightglass and check pressures. 2. Check for dirty evaporator coil, dirty filters, dampers closed, iced evaporator, proper belt adjustment, proper motor amps, duct design 3. Check head pressure, check and adjust TXV if not functioning properly, check pressure drop across filter drier. 4. Check calibration of switch.
C. Compressor starts but cuts out on high pressure switch.	<ol style="list-style-type: none"> 1. Refrigerant overcharge. 2. Condenser fan control has incorrect setting. 3. Fan motor defective. 4. Condenser coil inlet obstructed or dirty. 5. Air or non-condensables in system. 6. Defective high pressure switch. 7. Restriction in discharge or liquid line. 	<ol style="list-style-type: none"> 1. Check pressures, charge by sub cooling. 2. Check calibration of low ambient control. 3. Check fan motor. 4. Check coil and inlet clearances and for possible air recirculation. 5. Check high side equalized pressure reading with equivalent outdoor temperature. 6. Check calibration of switch. 7. Check discharge and liquid line pressures, check TXV.
D. Compressor cuts out on thermal overload.	<ol style="list-style-type: none"> 1. Low voltage. 2. Sustained high discharge pressure. 3. High suction and discharge pressures. 4. Defective compressor overload. 5. Defective run capacitor. 6. Improper refrigerant charge. 7. Bearings or pistons too tight. 8. Allow time for compressor to cool. 	<ol style="list-style-type: none"> 1. Check voltage. 2. Check running amperage and conditions described under "high discharge pressure." 3. Check TXV setting, check for air in system. 4. Allow compressor to cool for two hours if compressor is hot. Recheck for open circuit. 5. Check run capacitor for compressor and fan motor. 6. Check subcooling. 7. Check for low oil level. 8. Check dome temperature of the compressor.
E. Compressor cuts out on oil failure control (semi-herm.)	<ol style="list-style-type: none"> 1. Low oil level. 2. Defective oil pump. 3. Defective control. 4. Liquid refrigerant is entering crankcase. 	<ol style="list-style-type: none"> 1. Check crankcase sightglass - add oil to bring level to midway in sightglass. 2. Check oil pump. 3. Check oil failure control for calibration. 4. Compressor will be wet. Check crankcase heater or cause for liquid feedback.
F. Noisy compressor.	<ol style="list-style-type: none"> 1. Scroll compressors are rotation sensitive. 2. Refrigerant overcharge. 3. Excessive or insufficient oil in compressor 4. Liquid floodback. 5. Tubing rattle. 6. Compressor defective. 	<ol style="list-style-type: none"> 1. Reverse wiring at disconnect switch, recheck for correct evaporator blower rotation. 2. Check pressures and subcooling. 3. Check oil level in hermetic compressors. Check total ϵ crankcase. 4. Check TXV setting. Check for refrigerant overcharge. oil as recommended. 5. Dampen tubing vibration by taping or clamping. Bend tubing away from contact where possible. 6. Check internal parts (semi-herm.)

TROUBLE SHOOTING GUIDES CONTINUED

General Refrigeration Circuit Continued

SYMPTOM	POSSIBLE CAUSE	REMEDY
G.Noisy unit operation.	<ol style="list-style-type: none"> 1.Blower rotational noise. 2.Air noise. 3.Chattering contactor. 4.Tubing rattle. 	<ol style="list-style-type: none"> 1. Check blower, motor and drive for faulty adjustment or noisy bearings, loose parts, blower out of balance. 2. Check ductwork. Air velocity too high. 3. Check for adequate control voltage, check for shorts or breaks, check thermostat, check contact points. 4. Dampen by taping or clamping, bend tubing away from contact when possible.
H.High suction pressure.	<ol style="list-style-type: none"> 1.Excessive load on evaporator coil. 2.Broken compressor valves (Scroll compressors do not have valves.) 3.Compressor is unloaded. 4.Leaking check valve. 5.Expansion valve not secured to suction line or TXV defective. 	<ol style="list-style-type: none"> 1. Check for high entering wet bulb temperature. Check for excessive airflow. 2. Remove head (semi-herm.) inspect reeds. Scroll compressors should not be pumped down below 5 psig. 3. Check head pressure, check and adjust TXV if not functioning properly, check pressure drop across filter drier. Re-calibrate unloader pressure switch. 4. Check temperature across check valve. 5. Check the TXV, ensure bulb is insulated.
I.High discharge pressure.	<ol style="list-style-type: none"> 1.TXV setting. 2.Air inlet to condenser dirty or obstructed. 3.Condenser fan motor defective. 4.Condenser fan control has incorrect setting. 	<ol style="list-style-type: none"> 1. Check TXV setting and calibrate superheat. 2. Check for proper clearances and possible air recirculating. 3. Check condenser fan motor and run capacitor. 4. Check calibration of low ambient head pressure control.
J.Suction pressure too low.	<ol style="list-style-type: none"> 1.Refrigerant undercharge. 2.Blower running backward. 3.Loose blower, pulley or belts. 4.Defective or improperly adjusted expansion valve. 5.Dirty filter. 6.Too little air flow or low entering air temperature. 7.Restriction in suction or liquid line. 	<ol style="list-style-type: none"> 1. Check pressures and subcooling. 2. Interchange any two wires from 3 phase disconnect. 3. Check drive pulley alignment, belt tension. 4. Check superheat and adjust TXV. 5. Check filter and evaporator coil. 6. Check airflow and entering air wet bulb conditions. 7. Check refrigerant circuit for restriction
K.Head pressure too low.	<ol style="list-style-type: none"> 1.Insufficient refrigerant charge. 2.Defective or improperly adjusted expansion valve. 3.Low suction pressure. 4.Condenser fan control setting. 5.Defective compressor. 	<ol style="list-style-type: none"> 1. Check subcooling, check for leak. 2. Check sub cooling and adjust TXV. 3. See "suction pressure too low" above. 4. Check calibration of low ambient control. 5. See "high suction pressure" above.
L.Compressor short cycles.	<ol style="list-style-type: none"> 1.Thermostat location or malfunction. 2.Improper refrigerant charge. 3.Defective high or low pressure control. 4.Liquid floodback. 5.Defective expansion valve. 6.Poor air distribution. 7.High discharge pressure. 8.Leaking discharge valves in compressor. 	<ol style="list-style-type: none"> 1. Check thermostat, check heat anticipator setting. 2. Check subcooling, verify superheat. 3. Check high or low pressure switch. 4. Possible tight bearings. 5. Check TXV and superheat. 6. Check ductwork for recirculating. 7. See "high discharge pressure" above. 8. See "high suction pressure" above.
M.Running cycle too long or unit operates continuously.	<ol style="list-style-type: none"> 1.Refrigeration undercharged. 2.Dirty filter or evaporator coil. 3.Dirty or clogged condenser coil. 4.Air or other non-condensables in system. 5.Defective compressor. 6.Restriction in suction and liquid line. 7.Control contacts stuck. 	<ol style="list-style-type: none"> 1. Check subcooling. 2. Check filter, coil and airflow. 3. Check coil and airflow. 4. Check equalized high side pressure with equivalent outdoor temperature. 5. Check compressor for proper operation. 6. Check for restrictions in refrigerant circuit. 7. Check thermostat, shorts in wiring, slave relay compressor contactor

TROUBLE SHOOTING GUIDES CONTINUED

General Refrigeration Circuit Continued

SYMPTOM	POSSIBLE CAUSE	REMEDY
N. Supply air temperature too high.	<ol style="list-style-type: none"> 1. Refrigerant undercharge or leak in system. 2. Evaporator plugged with dirt or ice. 3. Improperly adjusted or defective expansion valve. 4. Defective compressor. 5. High discharge pressure. 6. Airflow is too high. 	<ol style="list-style-type: none"> 1. Check subcooling and check for leaks. 2. Check evaporator, airflow and filter. 3. Check superheat and adjust TXV, check bulb. 4. Check compressor for proper operation. 5. See "high discharge pressure" above. 6. Check external static pressure.
O. Supply air temperature	<ol style="list-style-type: none"> 1. Airflow is too low. 2. Return air temperature too low. 	<ol style="list-style-type: none"> 1. Check evaporator coil, filter, check for closed dampers, grills, drive for loose parts, belts, misalignment, check external static pressure. 2. Check entering air wet bulb conditions.
P. Liquid line too hot.	<ol style="list-style-type: none"> 1. Refrigerant undercharge. 2. High discharge pressure. 	<ol style="list-style-type: none"> 1. Adjust the charge by subcooling. 2. See "high discharge pressure" above.
Q. Liquid line frosted or wet.	<ol style="list-style-type: none"> 1. Restriction in liquid line. 	<ol style="list-style-type: none"> 1. Restriction upstream of point of frosting.
R. Suction line frosting.	<ol style="list-style-type: none"> 1. Insufficient evaporator air flow. 2. Restriction in suction or liquid line. 3. Malfunctioning or defective expansion valve. 	<ol style="list-style-type: none"> 1. Check airflow, check drive for loose parts, belts, closed dampers. 2. Restriction upstream of point of frosting. 3. Check bulb of TXV.
S. Blower motor not running.	<ol style="list-style-type: none"> 1. Improper wiring. 2. Defective motor. 3. Defective thermostat or control circuit. 4. Motor off on overload protector. 	<ol style="list-style-type: none"> 1. Check wiring diagrams. 2. Check motor and controller. 3. Check control circuit. 4. Allow motor to cool, check amperage.

Varispeed™ Condenser Head Pressure Control

SYMPTOM	POSSIBLE CAUSE	REMEDY
A. No fan operation.	<ol style="list-style-type: none"> 1. Input pressure is below operating range. 2. No 24 volt control voltage 3. No input pressure to control. 4. Bad fan motor. 5. Pressure transducer problem. 	<ol style="list-style-type: none"> 1. No problem, normal operation. 2. Check for 24 V AC at control. 3. Check alignment of capillary fitting. Schrader valve depressor must depress Schrader valve enough to allow pressure into capillary. 4. Disconnect power. Place a jumper from L1 to M1 and connect power. If fan does not start, motor is bad and should be replaced. 5. Disconnect 6 pin connector from right side of control. Place a jumper wire between third pin from the top and bottom pin on the control (not the cable). If fan goes to full speed, check for input pressure. If it has been determined there is adequate pressure, the transducer is bad and the control must be replaced.
B. Fan stops when pressure reaches the high end of the operating range.	<ol style="list-style-type: none"> 1. Control is not wired correctly. 	<ol style="list-style-type: none"> 1. See wiring diagrams.
C. No fan modulation (On-Off Operation)	<ol style="list-style-type: none"> 1. Control is not wired correctly. 	<ol style="list-style-type: none"> 1. See wiring diagrams.
D. Fan starts at full speed.	<ol style="list-style-type: none"> 1. Control is not wired correctly. 	<ol style="list-style-type: none"> 1. See wiring diagrams.
E. Erratic fan operation.	<ol style="list-style-type: none"> 1. Control is not wired correctly. 2. Dirty or blocked condenser coil. 	<ol style="list-style-type: none"> 1. Check to see if control voltage (24 V AC) is on same phase as motor. 2. Clean condenser coil.
F. Fan motor is cycling on thermal over	<ol style="list-style-type: none"> 1. Dirty or blocked condenser coil. 2. Wrong motor for fan speed control application. 	<ol style="list-style-type: none"> 1. Clean condenser coil. 2. Replace with motor approved for fan speed control application.

TROUBLE SHOOTING GUIDES CONTINUED

Hot Gas Bypass Regulator

SYMPTOM	POSSIBLE CAUSE	REMEDY
A. Erratic pressure control.	<ol style="list-style-type: none"> 1. Defective regulator. 2. Dirt causing regulator to bind. 3. Power source to hot gas solenoid or operation of the solenoid is intermittent. 	<ol style="list-style-type: none"> 1. Replace defective part. 2. Disassemble regulator and clean internal parts. Install strainer. 3. Determine if problem is caused by supply voltage, solenoid, or excessive MOPD. Make changes necessary to correct problem.
B. Regulator leakage.	<ol style="list-style-type: none"> 1. Dirt in regulator causing seat to remain open. 2. Worn or eroded seating surface on regulator. 	<ol style="list-style-type: none"> 1. Clean the regulator. Install strainer. 2. Replace defective part.
C. Regulator hunting (chattering) large fluctuations in controlled pressures.	<ol style="list-style-type: none"> 1. Regulator is oversized. 2. Regulator and liquid injection Thermo Valve have control interaction. 3. Regulator and cylinder unloaders have 	<ol style="list-style-type: none"> 1. Contact Addison manufacturer for correctly sized regulator. 2. Increase superheat setting. Dampen bulb response by repositioning. 3. Differential should be increased between the controls by lowering the regulator's set point.
D. Regulator will not provide pressure control.	<ol style="list-style-type: none"> 1. Regulator seat is restricted. 2. Pressure adjusting stem is set at a point so high that suction pressure never reaches the set point. 3. Strainer clogged at the regulator inlet. 4. MOPD exceeded across the solenoid or loss of source voltage. 5. Solenoid coil burned out. 6. Wrong type distributor for hot gas bypass to the evaporator. 	<ol style="list-style-type: none"> 1. Locate and remove stoppage. Install strainer. 2. Readjust the regulator. 3. Locate and remove stoppage. 4. Replace solenoid or troubleshoot the electrical problem. 5. Replace coil. 6. Install proper Venturi - Flo type distributor for low pressure drop.
E. Regulator fails to close.	<ol style="list-style-type: none"> 1. Dirt under seat of the regulator. 2. Diaphragm failure (leakage around the adjusting stem) 3. Pressure adjusting stem is set at a point so high that suction never reaches the set point. 4. Blocked external equalizer passage. 5. Worn or eroded regulator seat. 	<ol style="list-style-type: none"> 1. Locate and remove stoppage. Install strainer or drier filter. 2. Replace defective parts. 3. Readjust the regulator. 4. Locate and remove stoppage. Install strainer. 5. Replace defective part.

TROUBLE SHOOTING GUIDES CONTINUED

General Gas Furnace

See Instruction Manual Included with gas furnace(s) for trouble shooting details.

TROUBLE SHOOTING GUIDES CONTINUED

Maxitrol-Regulator

SYMPTOM	POSSIBLE CAUSE	FIELD TEST	REMEDY
A. Automatic control valve will not close despite full range of modulating voltage at terminals 1 and 2.	<ol style="list-style-type: none"> 1. Faulty automatic control valve. 2. Installation wiring error. 3. Amplifier is faulty. 	<ol style="list-style-type: none"> 1. Remove wire from valve, if valve doesn't close —valve is faulty. 2. Remove wire from amplifier terminal 10 and 11. If valve remains open check for miswiring. 3. If AC voltage will not drop to zero at terminals 8 and 11 when DC voltage at terminals 1 and 2 is above 20 V DC, amplifier is faulty. 	<ol style="list-style-type: none"> 1. Replace automatic control valve. 2. Correct wiring. 3. Replace amplifier.
B. Automatic control valve will not open despite full range of modulating voltage at terminals 1 and 2.	<ol style="list-style-type: none"> 1. Faulty automatic control valve. 2. Open wire to automatic valve. 3. Amplifier is faulty. 	<ol style="list-style-type: none"> 1. Read voltage across valve terminals. If 24 V AC, valve is faulty. 2. Read voltage across terminals 8 and 11 on amplifier. If 24V AC, check for open circuit to automatic valve. If space temperature is less than 60° or greater than 85°F. 3. If AC voltage reading remains zero when DC voltage at terminals 1 and 2 is below 14V DC, amplifier is faulty. If space temperature is less than 60° or greater than 85°F. 	<ol style="list-style-type: none"> 1. Replace automatic control valve. 2. Correct wiring. 3. Replace amplifier.
C. No gas flow.	<ol style="list-style-type: none"> 1. Faulty power supply. 2. MR valve installed backward. 	<ol style="list-style-type: none"> 1. Read voltage at amplifier terminals 8 and 14 (24 V AC). 2. Arrow on MR valve should point in direction of gas flow. 	<ol style="list-style-type: none"> 1. Power supply must be 24V AC. 2. Install properly.
D. Continuous high fire.	<ol style="list-style-type: none"> 1. Room Override Thermostat, if used, calls for heat. 2. Open circuit in sensing and setting circuit. 	<ol style="list-style-type: none"> 1. Remove T115 wires from amplifier terminals 3 and 14. 2. Disconnect and measure across wires connected to amplifier between terminals 3 and 4 (A1010). Should read between 8,000 and 12,000 ohms. 	<ol style="list-style-type: none"> 1. If proper operation is obtained, check thermostat wiring for shorts. Rotate thermostat dial above and below room temperature to prove thermostat function. 2. If above 12,000 ohms check circuit for open or loose wires.
E. Continuous high fire but automatic valve cycles.	<ol style="list-style-type: none"> 1. Open circuit in wiring to MR valve. 2. Plunger jammed or installed upside down. 3. Faulty MR valve. 	<ol style="list-style-type: none"> 1. Check wiring for defects. 2. Plunger should be smooth and clean and operate freely in solenoid sleeve. 3. Measure voltage across MR valve. 	<ol style="list-style-type: none"> 1. Replace wiring if necessary. 2. Clean or replace plunger.
F. Furnace won't activate due to constant high modulating voltage (above 17 VDC).	<ol style="list-style-type: none"> 1. Short circuit in sensing and setting circuit 	<ol style="list-style-type: none"> 1. Disconnect and measure across wires connected to amplifier terminals 3 and 4 (A1010). Should read between 8,000 and 12,000 ohms. 	<ol style="list-style-type: none"> 1. If below 8,000 ohms check circuit for shorts or miswiring.

TROUBLE SHOOTING GUIDES CONTINUED

Maxitrol-Regulator Continued

SYMPTOM	POSSIBLE CAUSE	FIELD TEST	REMEDY
G. Continuous low or medium fire, but automatic valve cycles correctly.	<ol style="list-style-type: none"> Heat load requires low fire only. Plunger and/or maximum spring missing. Jammed plunger. Other valves faults. Inadequate supply pressure. 	<ol style="list-style-type: none"> Increase temperature setting 10 degrees. Check for parts. Examine. Plunger should be clean, smooth, and operate freely in solenoid sleeve. Remove wire from MR valve. Remove max. adjustment spring from MR valve, push down on plunger. Insufficient manifold pressure with furnace operating indicates supply is too low. 	<ol style="list-style-type: none"> If heater goes to high fire, system is working correctly. Install correct parts. Clean, or replace plunger if necessary. If MR valve remains on low fire, valve may be faulty. Check for obstruction in gas pipe ahead of controls. Increase gas pressure if possible.
H. Incorrect discharge air temperature.	<ol style="list-style-type: none"> Calibration. 	<ol style="list-style-type: none"> Check seal on calibration potentiometer. 	<ol style="list-style-type: none"> Recalibrate per "Temperature Calibration" procedure.
I. Erratic or severely pulsating flame.	<ol style="list-style-type: none"> Dirty or sticking plunger. Loose or broken wiring. Erratic voltage. 	<ol style="list-style-type: none"> Examine. Plunger should be clean, smooth, and operate freely in solenoid sleeve. Inspect wiring. Observe DC voltage across amplifier terminals 1 and 2. 	<ol style="list-style-type: none"> Clean or replace plunger if necessary. Correct wiring. If erratic or pulsating DC voltage is observed and wiring shows no defects, replace amplifier. If erratic or pulsating voltage continues, contact Addison.

*Control circuits external to the Maxitrol-Regulator and Amplifier can cause burner malfunction. Always check gas valve to be certain it is turned on, and check limit controls for normal operation.

Addison Limited Warranty

The following is the Limited Warranty provided by Addison (a trade name of RG Adding LLC, herein "Seller") to any customer (herein "Buyer") for any goods and services (a "deliverable"):

1. **Limited Warranty.** Seller provides such warranty as set forth in any instruction manual provided with the deliverable, or if there is no such warranty or instruction manual, Seller warrants to Buyer that such deliverable will be free from defects in material and workmanship (in either case the "Limited Warranty"). The Limited Warranty is not transferable or assignable and any such transfer or assignment is void. If Buyer is authorized by Seller to be a reseller of deliverables that are goods or an installing contractor, the Limited Warranty may be passed through to Buyer's customer, but Buyer shall not alter the Limited Warranty in any way.

The Limited Warranty does not cover service trips, service calls, costs of removing and reinstalling components and other labor charges or the cost of shipment of replacement parts. The Limited Warranty excludes damages due to (i) failure to install, operate or maintain deliverables as directed in any instruction manual provided or under applicable law or regulation, (ii) misuse, abuse, neglect or modification of a deliverable or any controls, in any way, (iii) improper service, use of replacement parts or accessories that are not specified by Seller, (iv) improper installation, or any relocation of a deliverable after initial installation, (v) incorrect supply, accident, fire, flood, acts of God or other casualty, (vi) use of a deliverable other than its intended purpose and normal usage, (vii) use of a deliverable in a corrosive atmosphere or any atmosphere containing contaminants, (viii) shipment of a deliverable (all claims must be filed with carrier), (ix) use of a deliverable in the vicinity of combustible or explosive materials, (x) any defect in a deliverable arising from a drawing, design, or specification supplied by or on behalf of Buyer, (xi) failure of parts, components, services or hook-ups not supplied by Seller, (xii) a deliverable not properly installed by a qualified contractor experienced in installing the deliverable, (xiii) inadequate air for combustion, (xiv) improper or rapid cycling of the compressor. No warranty coverage is applicable if Buyer cannot prove original purchase date and required annual maintenance history, the data plate and/or serial number on any deliverable is removed, defaced, modified or altered in any way, or Seller is not permitted to inspect the damaged deliverable.

In addition to the foregoing limitations, the Limited Warranty is not applicable to goods that are not gas fired infrared (radiant) heaters if the failure is due to (a) the deliverable having been allowed to exceed its proper temperature limits due to improper operation or maintenance or inadequate air circulation over it, or (b) damage is due to not having a stainless steel secondary if 50% or more of outside air is introduced, temperature rise at minimum firing rate is below 10° F. or the air temperature entering the heat exchanger is below 45° F.

Wear items or consumables such as belts, filters, coolant, etc. are not included under the Limited Warranty. The Limited Warranty does not cover the equipment and materials not manufactured by Seller; the warranty for those items shall be limited to only such warranty as that furnished by the manufacturer thereof as may properly be assigned to Buyer.

No person other than an executive officer of Seller has authority to change or extend the terms of the Limited Warranty, and Buyer confirms that no other warranty terms have been extended by Seller or are applicable to the deliverables. Change or extensions to the terms of the Limited Warranty are binding only if confirmed in writing by Seller's duly authorized executive officer.

2. **Limitation on Warranties/Damages.** Any claim under the Limited Warranty set forth in section 1 must be made within the following time periods or such claim is waived: (a) for gas fired infrared (radiant) heaters and gas fired heat exchangers, the claim must be made within thirty-six (36) months from the date of purchase by Buyer or forty-two (42) months from date of shipment by Seller, whichever occurs first; (b) for compressors, the claim must be made within sixty (60) months from the date of purchase by Buyer, (c) for replacement parts, the claim must be made within the later of twelve (12) months from the date of shipment by Seller or any Limited Warranty period remaining on the deliverable with which the replacement part is used or is intended to be used; and (d) for all other deliverables, the claim must be made within twelve (12) months from the date of start-up or eighteen (18) months from the date of shipment by Seller, whichever occurs first. For all deliverables (other than replacement parts) that require installation and start-up, the otherwise applicable warranty period shall be extended by an additional four (4) months if (i) the installation and start-up is performed by a contractor on Seller's current list of contractors who have successfully completed Seller's current installation course for that deliverable and (ii) full details of the installation and start-up are provided to Seller at or prior to the time any warranty claim is made.

Except as set forth in these terms, Seller makes no representation or warranty of any type, express or implied, including any warranty of merchantability, warranty of fitness for a particular purpose or warranty of

Addison Limited Warranty

non-infringement or warranty arising from any course of dealing, course of performance or usage of trade.

Seller will not under any circumstances, be liable for any special, indirect, punitive or consequential damages (even if Seller has been notified of the possibility of such damages) resulting from or related to a product including, without limitation, any loss of profits, or loss of opportunity. Some jurisdictions do not allow limitations on warranties or damages, so this limitation or exclusion may not apply to Buyer.

3. Remedy. Seller's sole obligation and Buyer's exclusive remedy with respect to any deliverable, whether arising in contract, tort (including negligence), strict liability, breach of warranty or otherwise, is limited to Seller, at its discretion, replacing or repairing the defective deliverable, providing replacement parts or issuing Buyer a credit equal to the price paid to Seller for such defective deliverable, and in no event will Seller's liability exceed the amounts actually received by Seller for any deliverable.

This exclusive remedy shall not be deemed to have failed its essential purpose so long as Seller is willing and able to repair or replace a defective deliverable or parts thereof or, also at Seller's option, to refund the price received by Seller for the defective deliverable, within a reasonable time after Buyer demonstrates that a defect exists in accordance with the terms and limitations of the Limited Warranty.

If you have questions, contact your installing professional. Should you need replacement parts or have additional questions, call or write Addison:

U.S.A.

7050 Overland Road,

Orlando, FL 32810

407.292.4400

on the web at: www.addison-hvac.com

Installation Code and Annual Inspections:

All installations and service of ADDISON equipment must be performed by a contractor qualified in the installation and service of equipment sold and supplied by Addison and conform to all requirements set forth in the ADDISON manuals and all applicable governmental authorities pertaining to the installation, service and operation of the equipment. To help facilitate optimum performance and safety, Addison recommends that a qualified contractor annually inspect your ADDISON equipment and perform service where necessary, using only replacement parts sold and supplied by ADDISON.

Further Information: Applications, engineering and detailed guidance on systems design, installation and equipment performance is available through ADDISON representatives. Please contact us for any further information you may require, including the Installation, Operation and Service Manual.

These products are not for residential use.

This document is intended to assist licensed professionals in the exercise of their professional judgment.



7050 Overland Road
Orlando, FL 32810 USA
Telephone: 407.292.4400
Fax: 407.290.1329
www.addison-hvac.com

© 2008 Addison All rights reserved. No part of this work covered by the copyrights herein may be reproduced or copied in any form or by any means - graphic, electronic, or mechanical, including photocopying, recording, taping or information storage and retrieval systems - without the written permission of Addison.

Printed in the USA

0571I-1500 TRSA/H 0411