

ATH

ADVANCED THERMAL HYDRONICS



HeatNet[®]

OnBoard

KN SERIES

Cast Iron Condensing Boilers

Models KN-2 and KN-4

HeatNet[®] Manual

Control Adjustment and Operation Instructions
for Mestek Firmware Version 2.8

Also read and follow:

KN Boiler Manual
KN Vent/Air Manual



KN-2 only



H

WARNING This manual is intended only for use by a qualified heating installer/technician. Read and follow this manual, all supplements and related instructional information provided with the boiler. Install, start and service the boiler only in the sequence and methods given in these instructions. Failure to do so can result in severe personal injury, death or substantial property damage.

WARNING **Do not use the boiler during construction.** Construction dust and particulate, particularly drywall dust, will cause contamination of the burner, resulting in possible severe personal injury, death or substantial property damage. The boiler can only be operated with a dust-free air supply. Follow the instruction manual procedures to duct air to the boiler air intake. If the boiler has been contaminated by operation with contaminated air, follow the instruction manual guidelines to clean, repair or replace the boiler if necessary.

CAUTION Affix these instructions near to the boiler/water heater. Instruct the building owner to retain the instructions for future use by a qualified service technician, and to follow all guidelines in the User's Information Manual.

The KN boiler — HeatNet® control

Control overview

The KN HeatNet control monitors boiler temperature and limit circuit inputs, modulating boiler firing rate to meet demand. The control uses microprocessor electronics, watching time-average response from the system to anticipate how much heat the system needs. Coupled with the five-to-one turndown of the KN boiler, this results in maximum possible condensing-mode operation. The KN boiler will provide unmatched seasonal efficiency.

Indoor air reset (IAR)

KN's unique approach to boiler output regulation is its Indoor Air Reset function. The control monitors the demand from up to 8 different zones. Watching the demand duration and response to supply temperature, averaging over time, the HeatNet control anticipates system needs. It sets boiler maximum firing rate and adjusts supply water temperature to fine-tune boiler heat output. All that is required to enable IAR is to connect thermostat circuit wires to the IAR inputs. The HeatNet control can also be configured for outdoor reset operation, but IAR provides response based on system behavior rather than just looking at outdoor temperature.

The HeatNet platform

HeatNet controls are designed to provide an integrated boiler management system on every boiler. The platform provides multiple levels of selectivity. HeatNet electronics can be operated as a simple single-boiler control, while still providing intelligent regulation of boiler firing rate to match system demand. With a few key strokes on the key pad, the HeatNet control can operate as a sophisticated multiple-boiler controller, using simple RJ45 cable interfacing between units. The control can even accept external control commands from building managements systems (Modbus standard, with optional bridge for BACnet or LonWorks) or 20-milliamp analog input from an external controller.

The control method used by the HeatNet control is based on digital communications, which eliminates the need for analog control signals. Analog signal inputs are supported, but a higher level of control precision, repeatability and feedback is gained with digital communications.

The HeatNet control can be versatile, providing for operation in multiple ways:

- Operation as a stand-alone boiler.
- Operation as a boiler in a boiler network, using the on-board HeatNet protocol.
- Operation as a member boiler in a boiler management system.

- Operation as a member of a remotely-controlled boiler network (20-milliamp regulation).
- Setpoint can be determined by the HeatNet control or by a 20-milliamp input signal.
- Network boilers can be operated by override commands for increased versatility.

PID response

The HeatNet control uses proportional-integral-derivative calculations to determine the response to boiler water temperature changes. This means it not only looks at how far away the water temperature is from the setpoint temperature, but how fast the temperature is changing and how it has responded over time. This ensures the boiler won't make sudden unnecessary changes in firing rate.

Multiple boiler operation

The HeatNet control easily interfaces with other HeatNet controls. Multiple boiler operation using HeatNet protocol only requires RJ45 cables daisy-chained from boiler to boiler and a few key strokes setting up control behavior. The master boiler is automatically selected by connecting a sensor lead to its HEADER sensor terminals. The HeatNet control recognizes the sensor and configures the boiler as the master. Other boilers only need to have an address assigned.

Among the advanced design features of the HeatNet control is the MOD-MAX setting. This limits the firing rate of all boilers to a pre-set maximum (50% by default). This means all of the boilers will be run at a very efficient level until all boilers are on. Only then can firing rate increase above this setting. Boiler rotation can be first-on/first-off, first-on/last-off, or true rotation (the HeatNet control monitors the total on time of all boilers, and rotates their usage so the total on time is the same for all).

Firmware Version 2.5 and greater is now compatible with HeatNet Mixed Boiler Systems. For more information on the operation of HeatNet Mixed Boiler Systems see the KN6-30 HeatNet Control Manual V3.47, which is available at www.knseries.com.

External limit monitoring & annunciation

In addition to controlling the boiler, the HeatNet control monitors external limits wired into the limit circuit connections. The control shuts down the boiler if a limit opens, and the digital display shows which limit failed. Monitored limits include high limit aquastat, flow, ignition control fault, inlet pressure, flue pressure and other optional or user-selectable limits."

The KN boiler — HeatNet® control

KN Control panel

(Located on boiler front — shown with keypad cover removed)

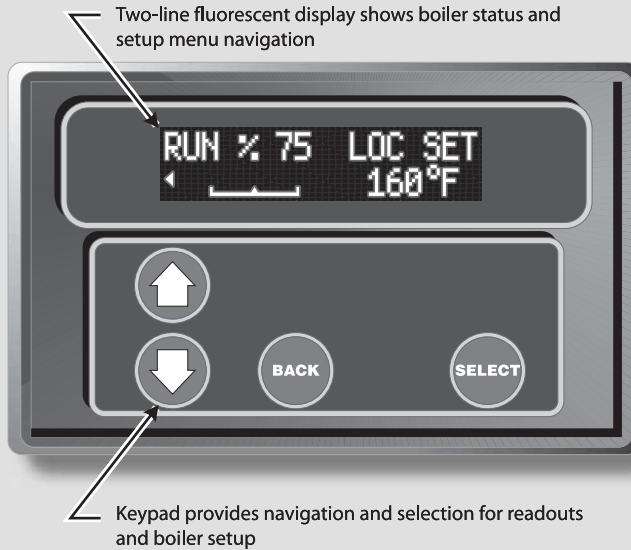

Electrical connection board

(Located in center panel on boiler right side)

(All field and boiler wiring connects here)

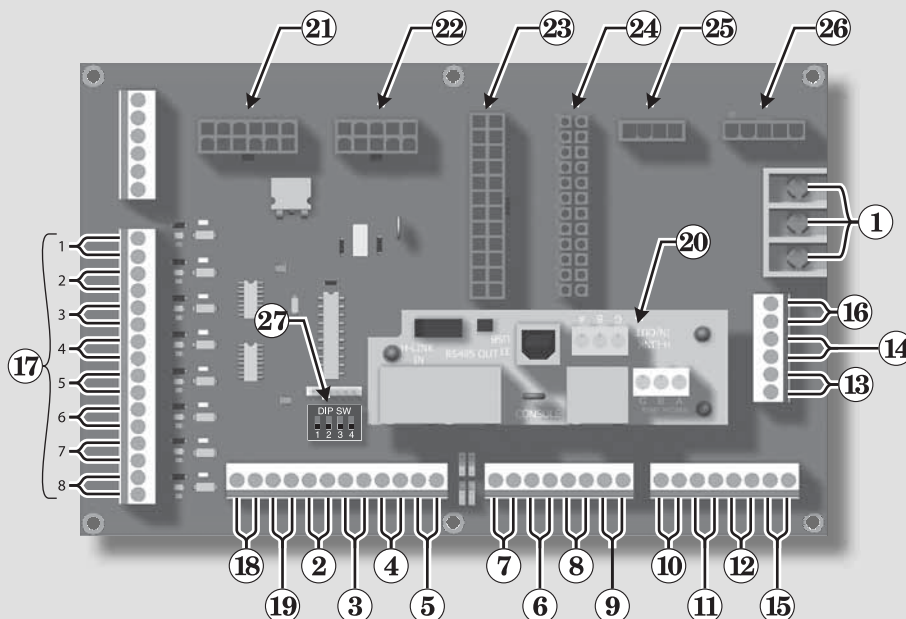

(All boiler wiring is made with non-interchangeable plug-in harnesses, connected to this board)

Wiring connections

1. Power wiring, 120 vac
2. Heat demand input
3. DHW demand input
4. Low fire terminals
5. High fire terminals
6. To boiler outlet water temperature sensor
7. To optional outdoor temperature sensor
8. To optional boiler return water temperature sensor
9. To optional header temperature sensor
10. To boiler postpurge pump (factory piped and wired)
11. To boiler circulator
12. Alarm output dry contacts
13. To external high limit and/or low water cutoff if desired
14. To flow switch, when used
15. Used to activate combustion air damper if desired
16. To combustion air damper proving switch, required when controlling combustion air damper
17. Indoor air reset inputs — connect to up to 8 zone thermostats
18. Optional 20 ma control signal input
19. Remote enable to start when operating on 20 ma input
20. Optional HeatNet communications board
21. Boiler wiring socket to blower and gas valve
22. Boiler wiring socket to pressure switches and ignition control
23. Boiler wiring socket to control panel
24. Boiler wiring socket to control panel
25. Boiler wiring socket to power switch
26. Boiler wiring socket to transformer
27. Termination DIP switches

KN
components

Contents



KN
HeatNet
Control panel

1 Method 1: HeatNet modulation – controlpage 5

- The KN HeatNet control can control up to (16) KN boilers using built-in software and hardware.
- Install a RS485 interface on each boiler and connect with RJ45 HeatNet cables (or shielded wires).
- The header water temperature setpoint can be set by the master boiler or by a 4-20ma input from an external controller.
- Member boilers can override master boiler control if they receive a contact closure on the Heat Demand or DHW Demand terminals.

2 Method 2: HeatNet modulation – BMSpage 14

- This method uses the KN control's built-in communications capabilities to accept Modbus protocol inputs from a building management system. The master boiler control sequences and modulates the boiler network to accomplish the demands from the building management system.
- Each boiler requires the RS485 interface board and cable, above.
- Boiler setup is essentially the same as for method 1, with the exception that each boiler must be assigned both a HeatNet network address and an address for the Modbus interface.
- An additional bus is required to interface with systems using BACnet or LonWorks protocol.
- The master boiler will take control and regulate the boiler network if signal from the BMS is lost or times out.

3 Method 3: External 4-20ma controlpage 16

- Up to 5 boilers can be controlled by an external control that provides a 4-20ma input signal. The external controls must also activate each boiler by closing a contact across the boiler's 4-20ma Remote Enable contacts.
- Member boilers can override external boiler control if they receive a contact closure on the Heat Demand or DHW Demand terminals.

4 Failsafe modespage 22

5 Control menus and adjustmentspage 23

- Operating parameters and control behaviors are set using the KN control's display/keypad interface.
- Refer to this section for the menu structure and explanations of the setting options.

6 Troubleshootingpage 35

7 Communication Registerspage 40

1

Method 1: HeatNet modulation – local control

WARNING **Electrical shock hazard** — Disconnect all electrical power sources to the boiler before making any electrical connections.

Label all wires prior to disconnection when servicing controls. Wiring errors can cause improper and dangerous operation! Verify proper operation after servicing.

Failure to comply with the above could result in severe personal injury, death or substantial property damage.

NOTICE The electrical connections to this boiler must be made in accordance with all applicable local codes and the latest revision of the National Electrical Code, ANSI /NFPA-70. Installation should also conform to CSA C22.1 Canadian Electrical Code Part I if installed in Canada. Install a separate 120 volt 15 amp circuit for the boiler. A properly rated shut-off switch should be located at the boiler. The boiler must be grounded in accordance with the authority having jurisdiction, or if none, the latest revision of the National Electrical Code, ANSI/NFPA-70.

Line voltage field wiring of any controls or other devices must use copper conductors with a minimum size of #14 awg. Use appropriate wiring materials for units installed outdoors.

Figure 1 Electrical connection board (see item 10, page 3 for location — Also see the wiring summary illustrations on the next pages)

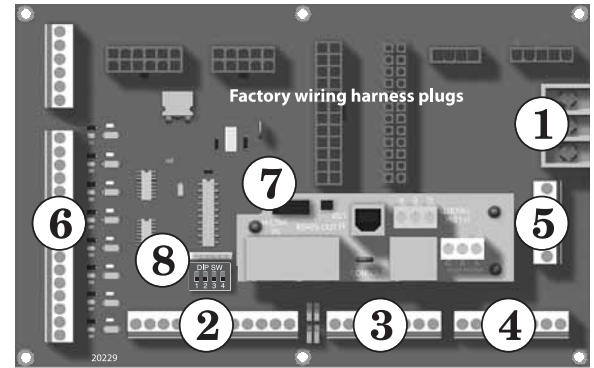
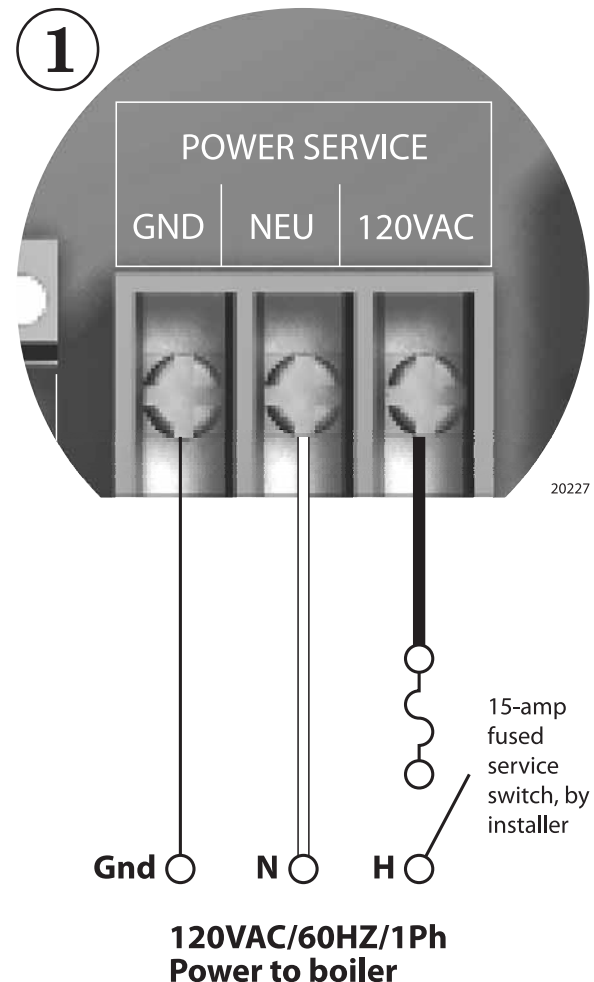

Figure 2 120VAC power service terminals on electrical connection board — See Figure 15 for location of the power terminal strip



Overview — control setup sequence

CAUTION **Follow the Boiler manual** — Install the boilers according to the KN Boiler manual before attempting to set up the control system.

1. Install all boilers per the Boiler manual.
2. Close the external gas valve on every boiler.
3. Wire all boilers following the guidelines in this section.
4. Attach a header sensor to the master boiler **ONLY**. The KN-2 control automatically configures the boiler with a header sensor as the master.
5. Set the master boiler control parameters using its display/keypad.
6. Set the master boiler's termination DIP switches.
7. Set the termination DIP switches on the member boilers.
8. Set the member boilers' control parameters using their display/keypads.
9. Follow the instructions in the Boiler manual to start up each boiler before proceeding further.
10. Finish by connecting cables between the communications boards of all of the boilers and verifying network operation.

Add communications modules

1. Insert a RS485 communications module onto each of the boilers' electrical connection panels, as shown in Figure 1.

Power supply (120 VAC)

1. See Figure 1 and Figure 2.
2. Connect minimum 14awg copper wire to the power connection as shown in Figure 2.
3. Install a fused service switch, mounted and installed in accordance with all applicable codes.

1

Method 1: HeatNet modulation – local control *(cont.)*

Circulator wiring

Postpurge circulator (KN-2 only)

- The circulator shipped installed with the boiler cannot be used for system circulation. It must be used as supplied from the factory. It circulates water after the boiler stops firing to prevent potential damage from heat pocketing in the top of the heat exchanger.
- The postpurge circulator is factory-piped and pre-wired. Do not change the usage, the wiring, the location or the piping.

Boiler circulator

- See the Boiler manual for circulator piping.
- Figure 3, Figure 4, and Figure 5 show wiring of the Boiler circulator (or boiler/system circulator) to the terminal strip of the KN-2 electrical connection board.
- DO NOT directly connect a circulator with a motor larger than 1/4 hp. For larger motors, install a circulator relay or motor contactor. Figure 3 and Figure 4 show the correct ways to install the boiler circulator using a relay or motor starter.

Figure 3 Wiring the boiler circulator using a circulator relay (required for motors over 1/4 hp)

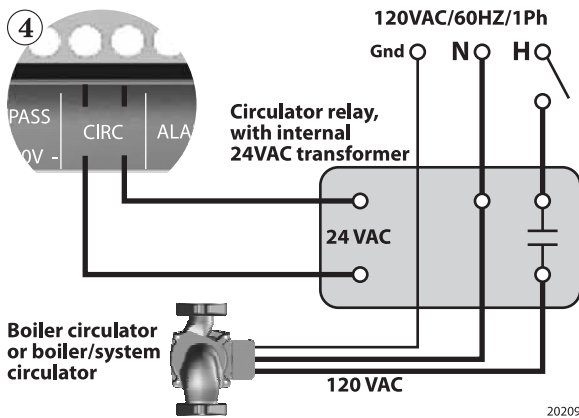

Figure 4 Wiring the boiler circulator using a relay or starter (required for motors over 1/4 hp)

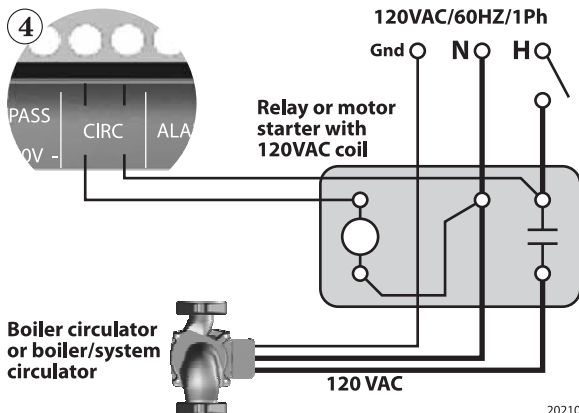
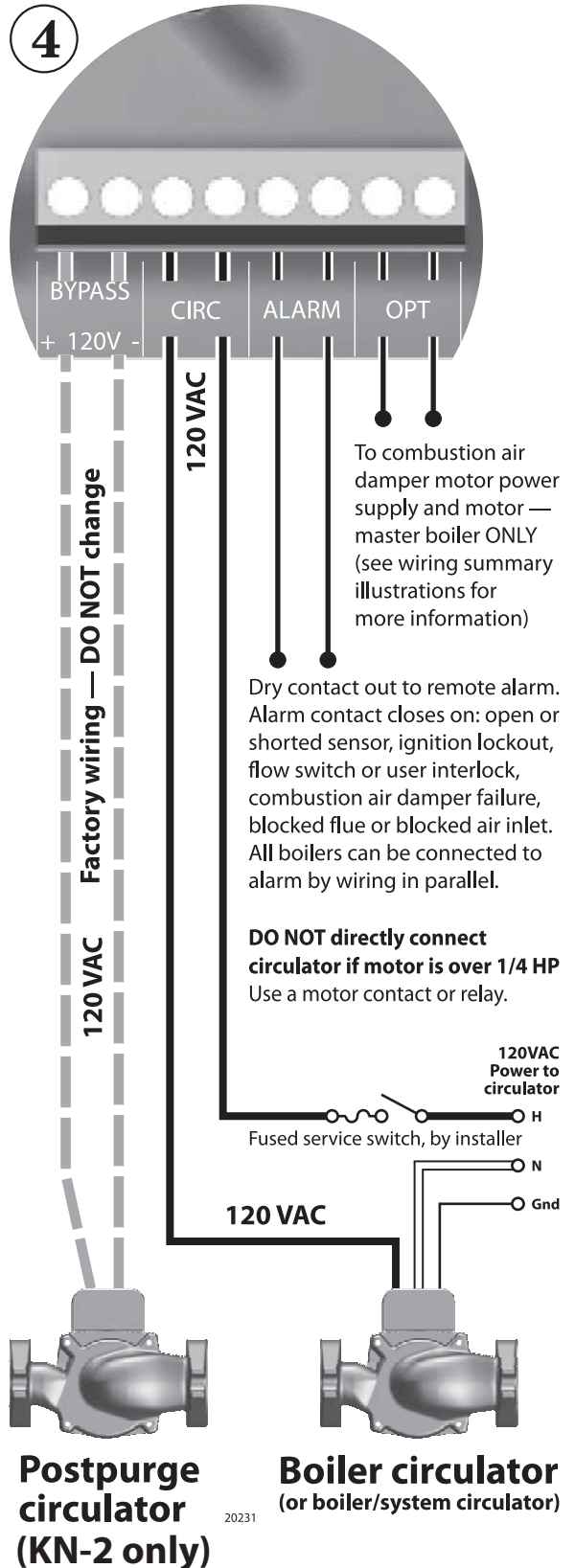

Figure 5 Circulator wiring terminal strip (see Figure 1 for location) — Also see the wiring summary illustrations on the next pages)



1

Method 1: HeatNet modulation – local control *(cont.)*

IAR (Indoor Air Reset) wiring, when used

- Heat Demand terminal connections — The end switch leads from the zone valves must connect to the Heat Demand terminals on the electrical connection board as shown in Figure 7.
- See Figure 6 for typical wiring to the IAR inputs when using 4-wire zone valves without a zone controller. For other applications, such as circulator relays or zone controllers, see Appendix A in the Boiler manual.

CAUTION Polarity — The connections to the **IAR** positive terminals (**IAR +**) must be to the same location on the zone valve as the thermostat wire, as shown in Figure A1. The connections to the **IAR** negative terminals (**IAR -**) must be from the zone valve terminal connected to the 24VAC common line, as shown. Connecting the wires incorrectly can cause the transformer to be shorted out and damaged. Verify the wiring with a voltmeter.

CAUTION Always use a voltmeter to check the leads coming from the end switches of the zone valves. With the thermostat calling for heat, connect the voltmeter leads across the wires coming from the end switches. If the meter shows a voltage reading, the zone valve wires are incorrect. Change the wiring and retest. **DO NOT** connect the wires to the boiler until you have tested as described. Incorrect wiring can damage the boiler control or other system components.

- If there is only one transformer feeding all of the zone valves in the system, you can omit the wires to the **IAR** negative terminals (**IAR -**) on all but one of the zone valves. This is because these terminals are jumpered internally on the electrical connection board. If there is more than one transformer, provide one wire from each transformer common side to one of the **IAR** negative terminals (**IAR -**).

Sensor wiring

- Header sensor is required** — A header sensor must be installed in the system supply piping. **Connect the header sensor ONLY to the master boiler.** Install the header sensor in an immersion well. Locate the sensor where it will accurately sense the system water supply temperature. Connect the sensor leads to the electrical connection board as shown in Figure 8.
- Outdoor reset application** — To operate with outdoor reset, purchase and install an outdoor sensor. Mount the sensor such that it is shielded from direct sunlight if possible and not likely to be covered by snow drifts or debris. Connect the outdoor sensor leads to the master boiler's electrical connection board as shown in Figure 8. (Member boilers could have their own outdoor sensor if they will be operated in override mode by closing the Heat Demand terminals.)
- Return water temperature sensor** — The return water temperature sensor is optional, only needed if you want to automatically control the boiler postpurge pump cycle time. Install the sensor in a well in the boiler return piping. Connect the sensor leads to the electrical connection board as shown in Figure 8. The Return water sensor can **OPTIONALLY** be used as a DHW sensor. The control would then regulate to this sensor for DHW demands. When used in this way the sensor must be moved to a position where it will sense the temperature of the water being supplied to the tank. For more information see the DHW SENSOR description in Table 8.
- Sensor wiring, return water temperature sensor** — Firmware Version 2.5 and greater monitors the temperature differential (Delta T) across the heat exchanger. If the Delta T exceeds the setting, the input to the boiler can be optionally limited.

DHW wiring

- To operate the boiler for domestic water heating with a storage tank, install and pipe the tank according to the tank manufacturer's instructions and the recommended piping diagrams in this manual. Consult the factory for applications not covered.
- The circulator used for DHW must be operated by a circulator relay or zone controller that is activated when the tank aquastat calls for heat, as shown in (Figure 7 - terminal #2).
- Connect the tank enable terminals across the DHW DEMAND terminals on the master boiler's electrical connection board as shown in Figure 7. (Member boilers could be connected to tank aquastats if they are piped appropriately and intended to operate in override mode.)

Figure 6 Indoor Air Reset wiring to IAR terminals with 4-wire zone valves and no zone controller (see Figure 7 for terminal block 6 location)

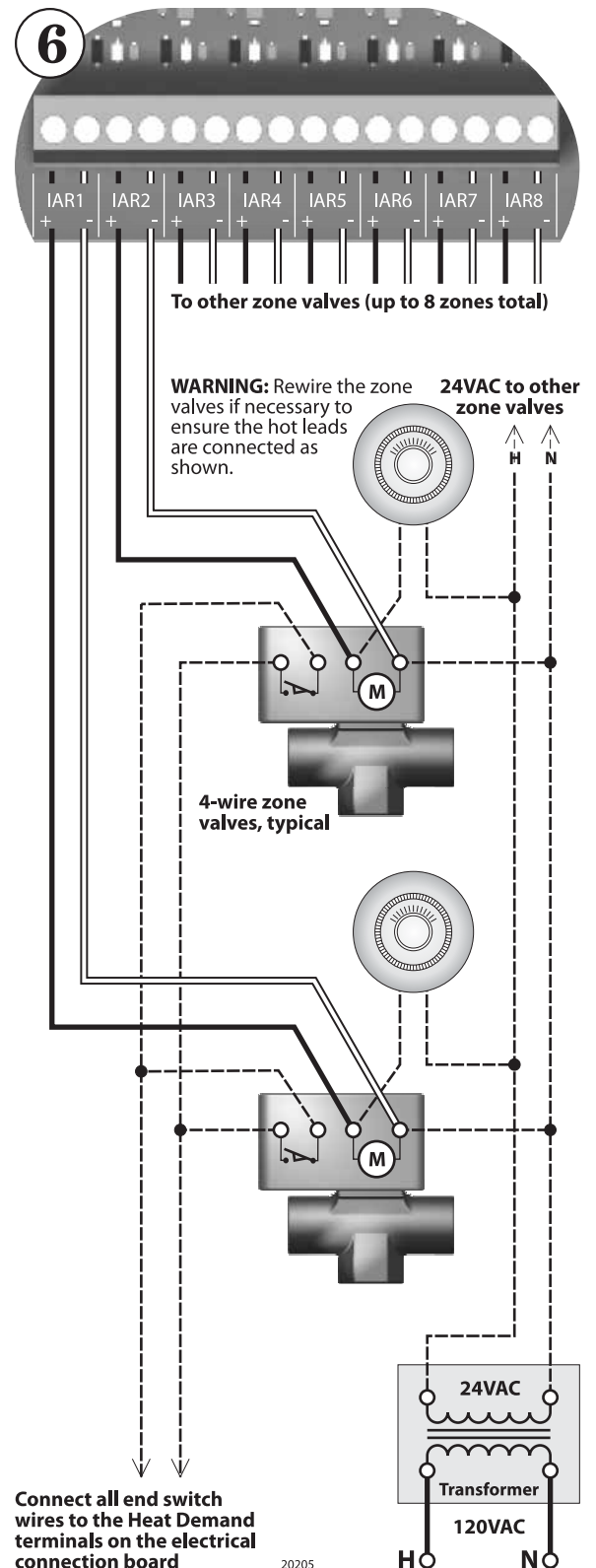

1

Method 1: HeatNet modulation – local control *(cont.)*

Figure 7 KN wiring summary — wiring to electrical connection board

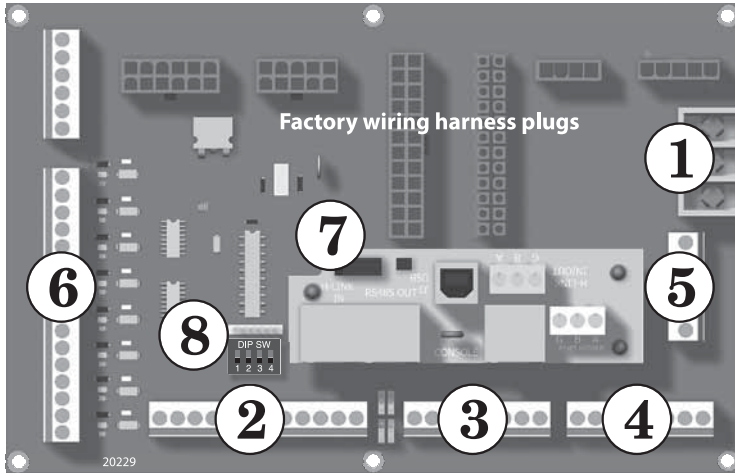

Electrical connection board

(Located in center panel on boiler right side)

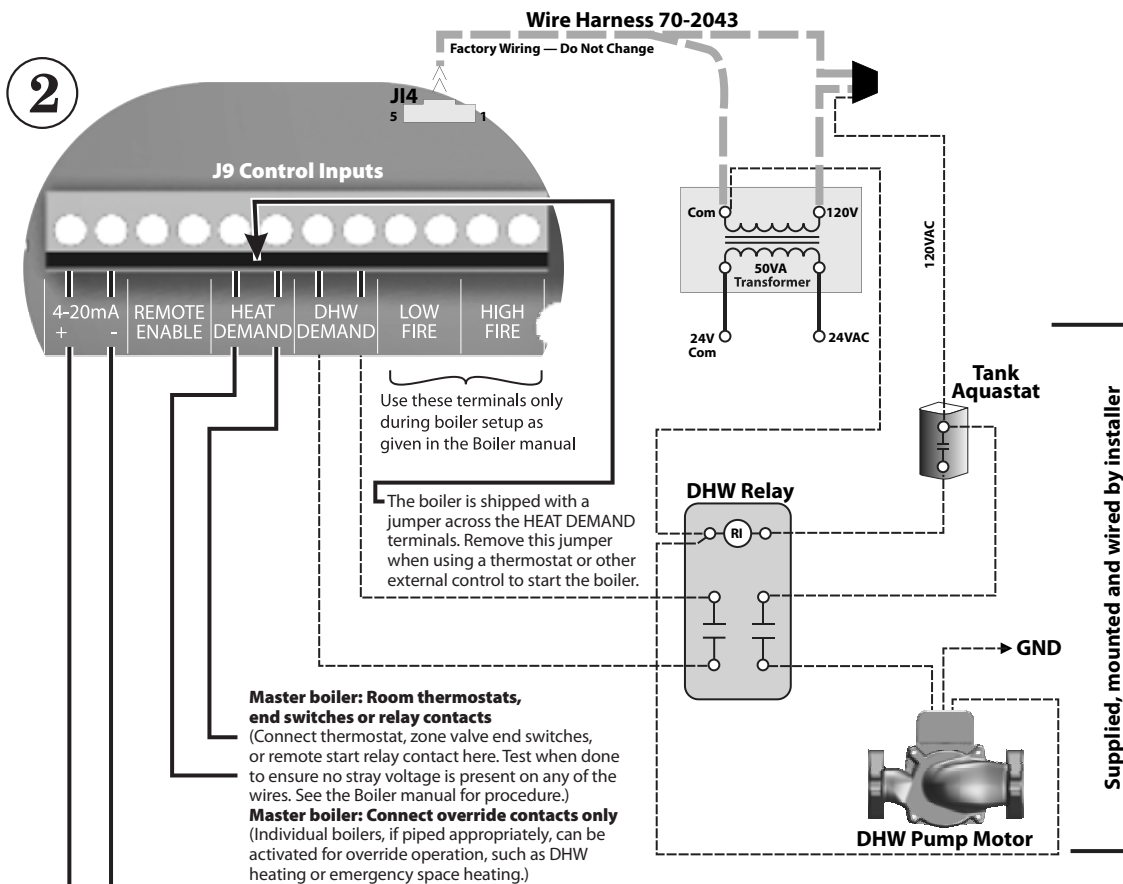
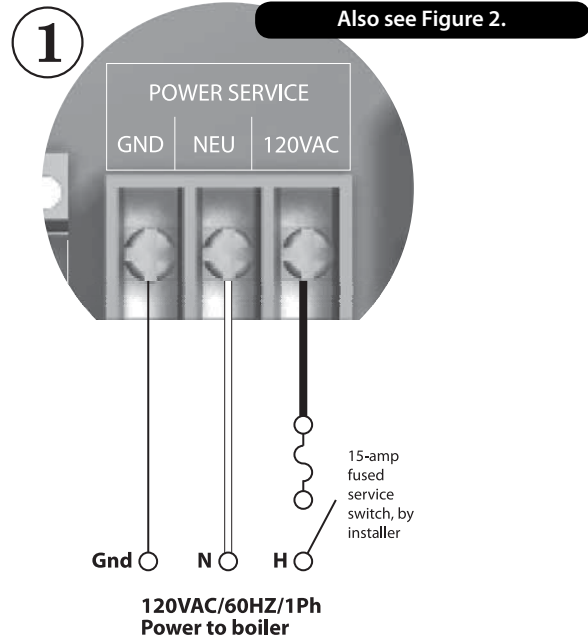

Master boiler: Room thermostats, end switches or relay contacts
(Connect thermostat, zone valve end switches, or remote start relay contact here. Test when done to ensure no stray voltage is present on any of the wires. See the Boiler manual for procedure.)

Master boiler: Connect override contacts only
(Individual boilers, if piped appropriately, can be activated for override operation, such as DHW heating or emergency space heating.)

4-20mA input option — for remote setpoint control ONLY
(Connect remote temperature control 4-20mA input wires here when **remote setpoint** is required. The setpoint temperature will be set by the 4-20mA signal. The corresponding setpoint values can be set in the 4-20mA INPUT menu.)

1

Method 1: HeatNet modulation – local control *(cont.)*

Figure 8 KN wiring summary — wiring to electrical connection board, continued (see Figure 7 for terminal strip locations)

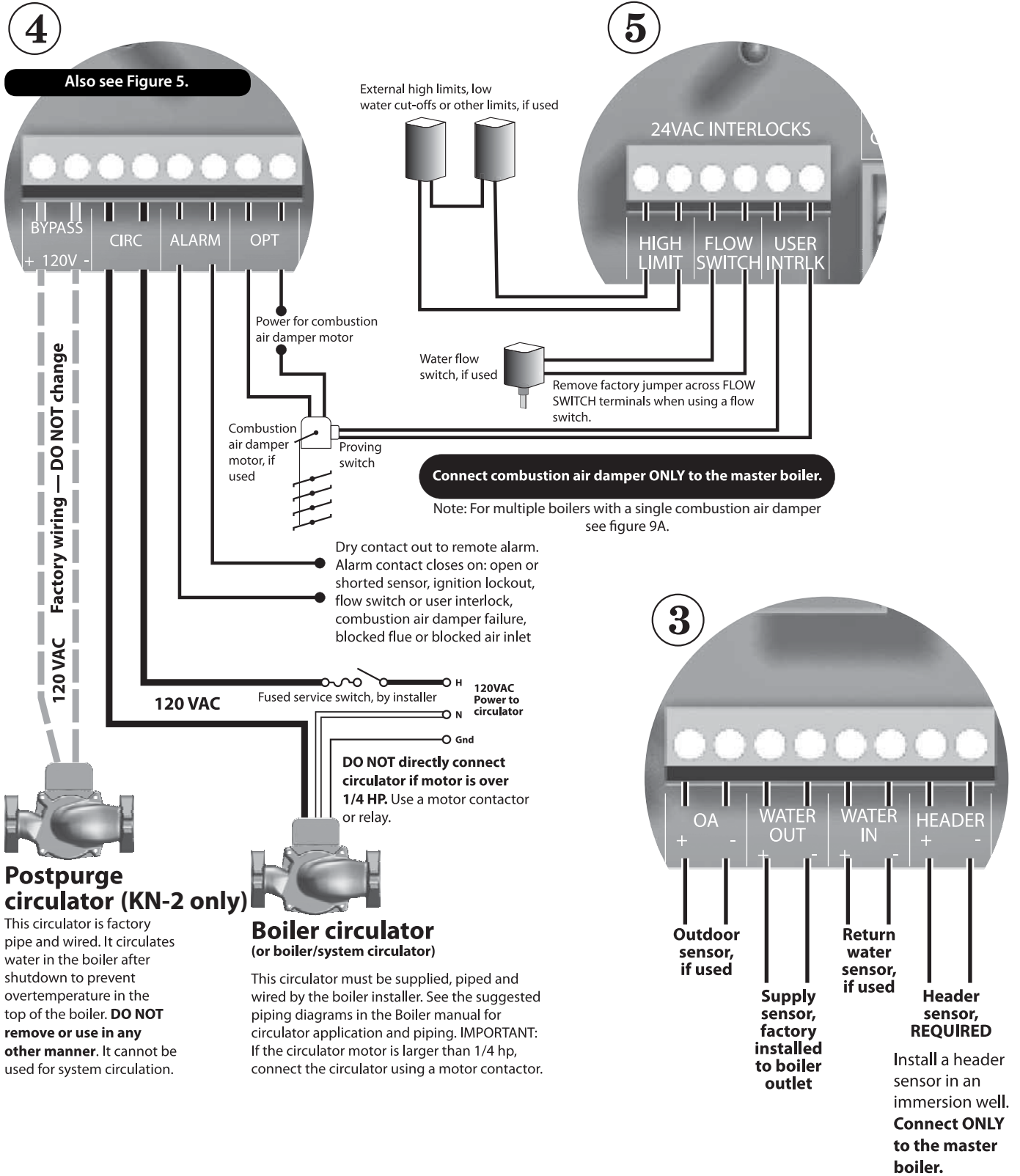

1

Method 1: HeatNet modulation – local control *(cont.)*

External interlocks

1. Wire external limits and flow switch, when used, as shown in Figure 8.
2. If wiring to and from a motorized combustion air damper, follow the guidelines given in Figure 8. Connect only to the master boiler.

CAUTION If any of the member boilers is to operate in override mode, and the system is equipped with a combustion air damper, you must provide special wiring in order to ensure the damper opens and proves when the boiler fires. This must be done without compromising the wiring between the master boiler and the damper.

Overrides — Control priorities

3. The KN control can provide override operation for any or all member boilers in a HeatNet network. This requires the boilers be piped with appropriate isolation piping and controls.
4. Override is done by closing a contact across the Heat Demand or DHW Demand terminals of any boiler. These priority inputs override all network controls or 4-20mA input controls to the boiler.
5. **DHW Demand** — The DHW Demand closure takes priority for ALL boilers, including the master and all members. When DHW Demand closes, the boiler or boilers immediately switch to DHW operation, including setting the water temperature to the DHW Setpoint.
6. **Space heating, Heat Demand** — If any member boiler sees closure across its Heat Demand terminals it will begin operation in space heating mode independent of commands from the master boiler or 4-20mA input source.

CAUTION Do not wire boilers for override operation unless the piping design provides automatic isolation of the overriding boilers. The master boiler would be unable to properly control system water temperature if member boilers were to input heat to the system without control from the master. DHW operation, in particular, would raise the supply temperature from overriding boilers to the DHW Setpoint.

NOTICE Override operation control setup — Boilers must be set up with operating parameters necessary during their override operation; i.e., local setpoint, DHW setpoint, etc.

7. Summary — priority sequence is:

Priority 1 = DHW Demand

Priority 2 = Heat Demand

Priority 3 = HeatNet input

Set termination DIP switches

1. The HeatNet network needs to recognize the beginning and end of the network. This requires setting the four DIP switches on each boiler's electrical connection board.
2. See Figure 9 for location of the switches.
3. See Table 1 for required settings. The table gives settings for HeatNet modulation — local control and for remote control from a building management system (Modbus protocol).
4. DO NOT connect the communications cables (or shielded wires) between boilers until all boilers have had parameters set and then been started up following all instructions in the KN Boiler manual.

Figure 9 Termination DIP switches (see item 7, Figure 7 for location)

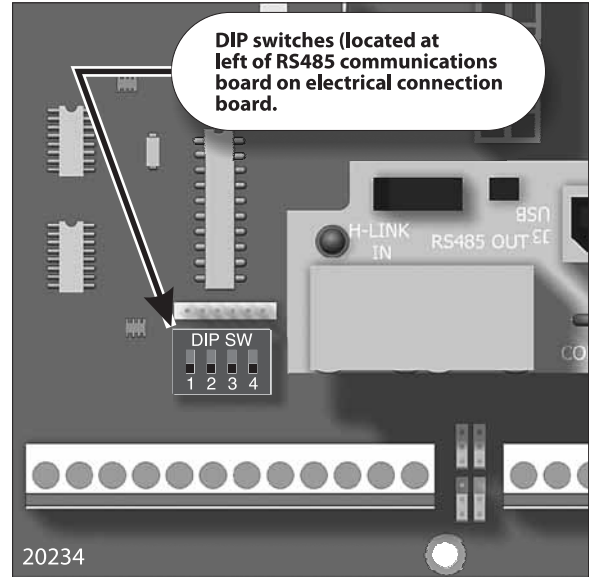

Table 1 Termination DIP switch settings

Boiler	HeatNet	Modbus (see note)
Master	Switch 1: ON Switch 2: ON Switch 3: OFF Switch 4: OFF	Switch 1: ON Switch 2: ON Switch 3: ON Switch 4: ON
Last member	Switch 1: ON Switch 2: ON Switch 3: OFF Switch 4: OFF	Switch 1: ON Switch 2: ON Switch 3: OFF Switch 4: OFF
Other members	Switch 1: OFF Switch 2: OFF Switch 3: OFF Switch 4: OFF	Switch 1: OFF Switch 2: OFF Switch 3: OFF Switch 4: OFF

Note: Modbus setup is for applications controlled by a building management system. For systems using BACnet or LonWorks, a bridge board is used to interface with the KN-2 control. The switch is "on" when in the down position and "off" when in the up position.

1

Method 1: HeatNet modulation – local control *(cont.)*

WARNING Close the external manual gas valve on every boiler before proceeding. DO NOT open any gas valve, or attempt to fire any boiler, until the boilers have been set up and verified following the instructions in the KN Boiler manual.

Failure to comply could cause a boiler failure, leading to possible severe personal injury, death or substantial property damage.

Set control parameters on keypads

NOTICE Before turning boilers on to set parameters, disconnect all call for heat wiring at the electrical connection boards. This will prevent the boiler for attempting to cycle during the setup process.

- See “Control menus and adjustments” for a complete list of control parameters and explanations.
- Carefully read the parameter explanations in Table 8.
- When adjusting the limit band, operating limit (OP LIMIT), local setpoint (LOC SETPOINT) and DHW setpoint, make sure the operating temperature bands do not overlap or cause potential for nuisance cycling.
- Indoor air reset — Use this option whenever possible. The indoor air technology monitors space heating demand to help the boiler operate at the highest possible efficiency throughout the season. To operate with IAR, you must wire to the IAR input terminals as described on page 18.
- System clock — Set the system clock on all boilers to ensure the time stamps will be accurate in the data logs.
- Turn on the power to each boiler and set the on/off switch to ON as you set its parameters.
- Use the boiler’s keypad to enter the parameters as described on page 23.
- After setting a boiler’s parameters, turn the power off to the boiler until you are ready to start the boiler up following the Boiler manual instructions.
- Set the master boiler and each member boiler, following the guidelines given in Table 2.

Start up boilers per KN Boiler manual

- Turn off power to all boilers.
- Follow all instructions in the KN Boiler manual to start up each boiler and verify operation.

Connect network cables

WARNING Electrical shock hazard — Turn off power to each boiler before attempting to connect the network cables.

NOTICE Before turning boilers on to check network operation, disconnect all call for heat wiring at the electrical connection boards. This will prevent the boiler for attempting to cycle during the setup process.

Master boiler cable

- Connect an RJ45 cable to the master boiler H-Link OUT block (item 2, Figure 10) or 3-wire shielded cable to the H-Link terminal strip (item 4, Figure 10). The other end of this cable will be attached to the first member boiler in following steps.

Table 2 Control parameters

Parameter	Master boiler	Member boiler (see notes)
HEAT BAND	Set on master boiler only	
LOC SETPOINT	Set	HD only ¹
SOURCE	Set	HD or DHW only ^{1,2}
DHW SETPOINT	Set if DHW will be used	DHW only ²
OP LIMIT	Set	Set
LIMIT BAND	Set	Set
IA RESET	ON if IAR is used, or set to OFF	Do not set
OA SHUTDOWN	Set ON if used or set to OFF	HDOA only ³
OA SETPOINT	Set if used	HDOA only ³
OA RESET	Set if used	HDOA only ³
OA SETPTS	Set if used	HDOA only ³
DELTA ENABLE	Set if used	Set if used
DELTA TEMP	Set if used	Set if used
PURGE TIME	Set if used	Set if used
ALWAYS ON	Set if used	Set if used
MASTER PUMP	Set if used	Do not set
NIGHT SETBACK	Set on master boiler only	
OPTIONS (all)	Set	Set
AUX FUNCTIONS	Set on master boiler only	
SYSTEM CLOCK	Set	Set
LOCAL ADD	Automatic	Set (beginning at 2)
CONSOLE ADD	Automatic	Set (beginning at 2)
MODULAR BOILER	Set on master boiler only	
MODULATION PID	Set on master boiler only	
FIRING MODE	Set on master boiler only	
SENSOR #	Set	HD/HDOA only ^{1,3}
TYPE	Set	HD/HDOA only ^{1,3}
CALIBRATE ?	On any boiler if required	
PASSWORD	Set	Set
COMMUNICATIONS	Set	Set
LOAD DEFAULTS	On any boiler if required	
SYSTEM	On any boiler if required	

Notes:

1 — HD Only means to set the parameter for a member boiler only if it is wired for Heat Demand override.

2 — DHW Only means to set the parameter for a member boiler only if it is wired for DHW Demand override.

3 — HDOA Only means to set these parameters only if the member boiler will be operated with outdoor reset when put in override mode with closure across its Heat Demand terminals (requires outdoor sensor connected to boiler).

1

Method 1: HeatNet modulation – local control *(cont.)*

- Turn on power to the master boiler and set its on/off switch to ON.
- You should hear at least 2 beeps.
- The control's firmware version number will display.
- After the control's timer finishes, the display will show STANDBY and SYS SET. This verifies that the master boiler is setup correctly as the master.

The same display will show on member boilers when there is a call for heat from the master boiler. When there is no call for heat at a member boiler, the display will show LOC SET instead.
- If the master is functioning correctly, the yellow LED's on the H-Link jack ports will blink. The blinking indicates that the master is trying to communicate with member boilers.
- If a FAULT message is displayed, clear the faults until the STANDBY message is displayed. Refer to troubleshooting suggestions at the end of this manual if you cannot resolve the issue.

Member boiler cables

- Begin with the first member boiler.
- Plug the other end of the master boiler's communications cable to the member boiler's input port (Figure 10, item 2 for RJ45 cable or item 4 for 3-wire cable).
- Connect cables to all of the member boilers by cabling from one to the next. Connect incoming cables to item 1 or 4, Figure 10. Connect outgoing cables to item 2 or 4. (Note that shielded cable wires will share terminals when using item 4.)

Check the network

- Turn the power on and the on/off switch to ON for all of the member boilers.
- Allow time for each boiler to initialize.
- After about 30 seconds, the master boiler should recognize the member boilers.
- Navigate to the BOILERS menu, then to HEAT NET BOILERS display. The master control will show the boilers it recognizes.
- If the display shows a blank space, such as "123_56789" the control does not detect the missing boiler (boiler 4). Check the yellow LED on the communication port of the missing boiler.
- NORMAL connection — LED should flash steadily, about twice per second.
- TERMINATION incorrect — LED will flash rapidly and stay on.
- OPEN connection — LED does not flash at all.
- If a FAULT message is displayed, clear the faults until the STANDBY message is displayed. Refer to troubleshooting suggestions at the end of this manual if you cannot resolve the issue.

Start the system

- Turn off power to all boilers.
- Connect all call for heat wiring to the boilers.
- Turn on power to all boilers and turn the on/off switches to ON.
- The boilers should now operate normally, as described in the Boiler manual.
- The master boiler will sequence and modulate boilers as necessary to control the water temperature.
- The master boiler will show the number of boilers firing as well as the temperature and heat band display. Use the UP/DOWN keys to scroll through the displays to watch the process of starting and stopping boilers.

Figure 10 RS485 communications board

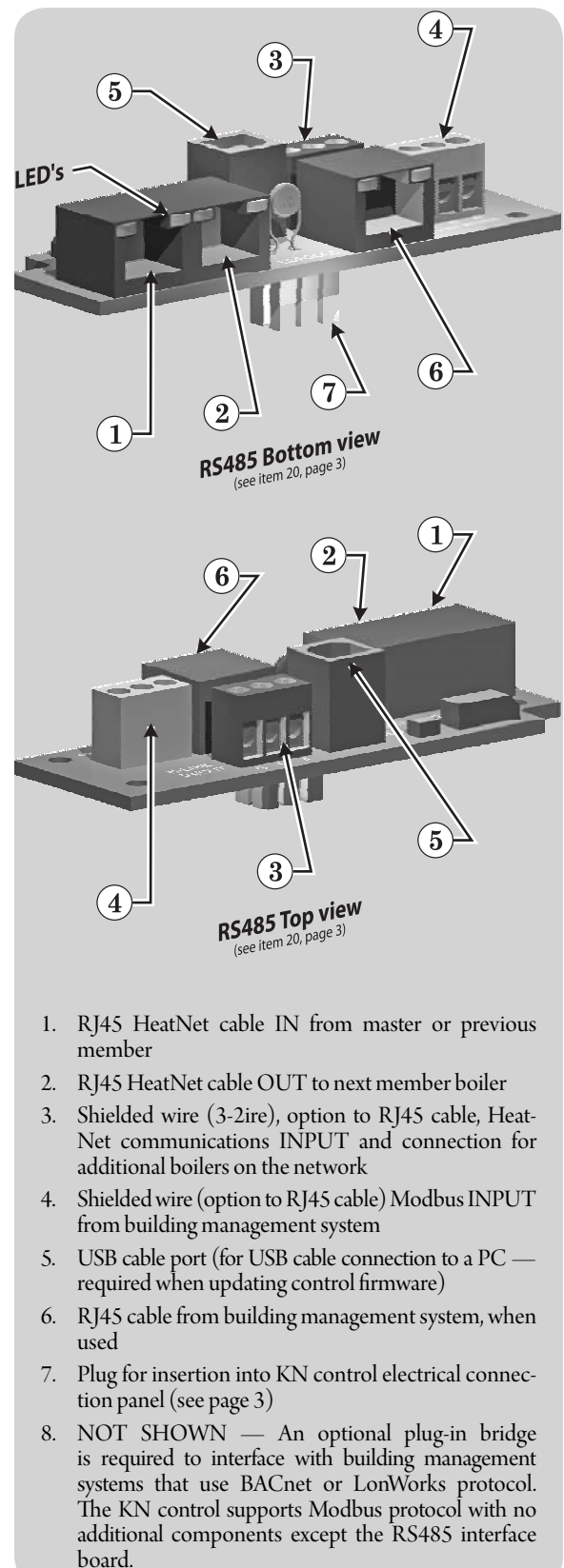

2

Method 2: HeatNet modulation – BMS control (Basic)

For Full Register Set see page 40

Overview

1. This method uses an RS485 digital communications cable with the Modbus protocol to control a boiler or HeatNet network.
2. The boiler or boiler network will operate as in the HeatNet local control method (Section 1 of this manual). But, instead of the HEAT DEMAND input, a software form of the HEAT DEMAND input is used (address 40001 — Boiler/System Enable/Disable).
3. The System Setpoint Timer needs to be loaded periodically to allow the HeatNet system to revert to local control from the master boiler in the event communications is lost.
4. The Modbus protocol allows writing and reading registers using Modbus commands. An optional BACnet or LonWorks bridge module can be used to connect the Modbus network to a BACnet or LonWorks network.
5. This method allows enabling and disabling the boiler or HeatNet system; changing setpoints; and reading boiler status or temperatures remotely, using digital commands from a Building Management System.
6. The master boiler assumes the role of MEMBER, RTU, 192Kb, 8 bits, Even Parity, 1 stop bit, when connected to a BMS.
7. The Member Boilers should not be connected to a BMS system other than to view read-only addresses.

Table 3 Modbus holding (read/write) registers

Address	Data Type	Description	Valid Values/Range
40001	Unsigned	Boiler/System Enable/Disable	0 = Disabled/Off 1 = Enabled/On
40002	Unsigned	System Setpoint Timer (1)	0 – 65535 seconds
40003	Unsigned	System Setpoint (1)	40°F – 220 °F
40004	Unsigned	Outdoor Air Reset Enable/Disable	0 = Disabled/Off 1 = Enabled/On
40005	Unsigned	Outdoor Air Setpoint	40°F -100 °F
40006	Unsigned	Water Temperature at High Outside Air	60°F -150 °F
40007	Unsigned	High Outside Air Temperature	50°F -90 °F
40008	Unsigned	Water Temperature at Low Outside Air	70°F -220 °F
40009	Signed	Low Outside Air Temperature	-35°F -40 °F
40010	Unsigned	Set Clock – Month (2)	0 – 11
40011	Unsigned	Set Clock – Day of Month (2)	1 – 31
40012	Unsigned	Set Clock – Year (2)	0 – 99
40013	Unsigned	Set Clock – Hours (2)	0 – 23
40014	Unsigned	Set Clock – Minutes (2)	0 – 59
40015	Unsigned	Set Clock – Seconds (2)	0 – 59
40016	Unsigned	Set Clock – Day of Week (2)	1 – Monday 7 – Sunday
40017	Unsigned	Set Clock – After the Set Clock Registers listed above have been written, a 1 must be written to this location to set the clock. (2)	1

MODBUS registers

1. See Table 3; Table 4; and Table 5 for register requirements.
2. The system setpoint timer and system setpoint work in tandem to externally control the operating setpoint.
3. The setpoint (countdown) timer should be loaded with a timeout value (in seconds) prior to writing the system setpoint.
4. When the timer reaches zero, the control assumes that the BMS is no longer operating and the local setpoint (saved on the master control) is reloaded.
5. This is a fail-safe feature used to help safeguard the system in case of BMS failure.
6. If the setpoint timer is not written, a default timeout value of 60 seconds is assumed.
7. To write the system clock, registers 40009 – 40015 must first be loaded with the correct date and time. Then, a 1 must be written to register 16 to write the date and time to the system clock.

Table 4 Boiler status flags

Bit	Description	Bit	Description
0	Disabled	16	Reserved
1	Local Override	17	Blower Running
2	Alarm	18	Ignition Alarm
3	Failed	19	Valve Alarm
4	Member Error	20	High Limit
5	Boiler Running	21	Reserved
6	Pump Running	22	Reserved
7	Reserved	23	Software Operator
8	Reserved	24	Header Sensor not Present
9	Reserved	25	Supply Sensor not Present
10	Reserved	26	Return Sensor not Present
11	User Interlock	27	Outside Air Sensor not Present
12	Reserved	28	— —
13	Water Prove (Flow) Interlock	29	Combination Air Damper
14	Reserved	30	Master Boiler
15	Main Valve	31	Present (Boiler Detected)

2

Method 2: HeatNet modulation – BMS control *(cont.)*

BACnet or LonWorks protocols

1. Install the correct bridge to adapt to building management systems using BACnet or LonWorks protocols.
2. The bridge translates the BACnet or LonWorks input to the Modbus protocol for compatibility with the HeatNet controls.

Wiring and set-up

1. Wire and set up the master boiler and member boilers exactly as for HeatNet modulation — local control applications. See page 5.
2. ALL control parameters must be set up just as for the local control method.
3. The ONLY difference in setup is the termination DIP switch settings. Use the settings for Modbus communications given in Table 1.
4. Connect communications cables (RJ45 or shield-wire cables) between the control communications boards as for the local control method.
5. Verify network operation BEFORE connecting the building management system.

Connect the BMS cable

1. DO NOT connect the building management system cable until the boiler network has been proven to operate independently. The system is designed to revert to local control by the master boiler should communications with the building management system be lost.
2. Turn off power to the master boiler.
3. See Figure 10. Connect an RJ45 cable to the BMS input port, item 6. Or use shielded wire cable, connected to terminal block, item 3.

Verify BMS/HeatNet operation

1. Turn on power to the master boiler.
2. Allow the master boiler to initialize.
3. Verify operation with the building management system.

Table 5 Modbus input (read-only) registers

Address	Data Type	Description	Valid Values/Range
30001	Unsigned	Boilers Running	0 – 16
30002	Unsigned	Modulation (% BTU Load)	0 – 100
30003	Signed	Header / System Temperature	32 – 250 °F
30004	Signed	Supply Temperature	32 – 250 °F
30005	Signed	Return Temperature	32 – 250 °F
30006	Signed	Outside Air Temperature	-40 – 250 °F
30007	Signed	Spare Input 1	-32768 to 32767
30008	Signed	Spare Input 2	-32768 to 32767
30009	Unsigned	Clock – Month	0 – 11
30010	Unsigned	Clock – Day	1 – 31
30011	Unsigned	Clock – Year	0 – 99
30012	Unsigned	Clock – Hours	0 – 23
30013	Unsigned	Clock – Minutes	0 – 59
30014	Unsigned	Clock – Seconds	0 – 59
30015	Unsigned	Clock – Day of Week	1 – Monday 7 – Sunday
30016 – 30047	Unsigned	Boilers 1 – 16 status flag (32-bit) registers. The upper 16-bits of each 32-bit register is stored at odd numbered addresses 30016 – 30046. The lower 16-bits of each 32-bit register is stored at even numbered addresses 30017 – 30047.	See the Boiler Status Flags Table Below
30048 – 30079	Unsigned	Boilers 1 – 16 runtime (32-bit) registers. The upper 16-bits of each 32-bit register is stored at odd numbered addresses 30048 – 30078. The lower 16-bits of each 32-bit register is stored at even numbered addresses 30049 – 30079. When the upper and lower registers are combined they form a 32-bit unsigned integer that is the number of seconds that the boiler has been running. For instance: (((Register 29) * 65536) + Register 30) = Boiler 1 runtime in seconds. Boiler 1 is the master boiler. Boilers 2 – 16 are member boilers.	0 – 4294967295 seconds

3

Method 3: External 4-20ma control

WARNING **Electrical shock hazard** — Disconnect all electrical power sources to the boiler before making any electrical connections.

Label all wires prior to disconnection when servicing controls. Wiring errors can cause improper and dangerous operation! Verify proper operation after servicing.

Failure to comply with the above could result in severe personal injury, death or substantial property damage.

NOTICE The electrical connections to this boiler must be made in accordance with all applicable local codes and the latest revision of the National Electrical Code, ANSI /NFPA-70. Installation should also conform to CSA C22.1 Canadian Electrical Code Part I if installed in Canada. Install a separate 120 volt 15 amp circuit for the boiler. A properly rated shut-off switch should be located at the boiler. The boiler must be grounded in accordance with the authority having jurisdiction, or if none, the latest revision of the National Electrical Code, ANSI/NFPA-70.

Line voltage field wiring of any controls or other devices must use copper conductors with a minimum size of #14 awg. Use appropriate wiring materials for units installed outdoors.

Figure 11 Electrical connection board (see item 10, page 3 for location — Also see the wiring summary illustrations on the next pages)

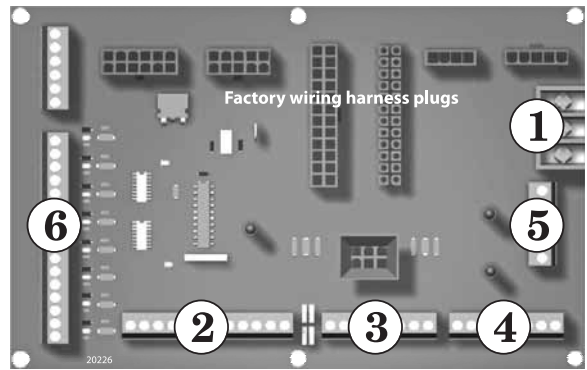
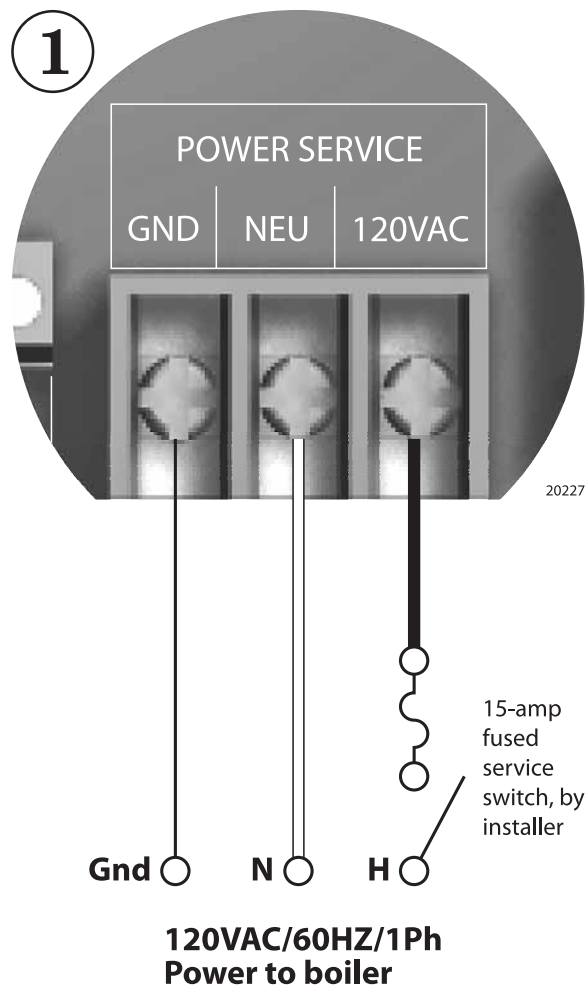

Figure 12 120VAC power service terminals on electrical connection board — See Figure 15 for location of the power terminal strip



Overview — control setup sequence

CAUTION **Follow the Boiler manual** — Install the boilers according to the KN Boiler manual before attempting to set up the control system.

1. This method can be used for from 1 to 5 boilers.
2. Install all boilers per the Boiler manual.
3. Close the external gas valve on every boiler.
4. Wire all boilers following the guidelines in this section.
5. DO NOT install a header sensor on any of the boilers.
6. Disconnect the wires to the boilers' Remote Enable terminals (and any override wiring to Heat Demand or DHW Demand terminals) to ensure there will be no call for heat while proceeding.
7. Set the boilers' control parameters using their display/keypads.
8. Follow the instructions in the Boiler manual to start up each boiler before proceeding further.
9. Finish by reconnecting call for heat wiring, then operating the complete system to verify operation in all modes.

Connect 4-20mA wiring

1. See Figure 16 for wiring from the 4-20mA controller. The control must provide the 4-20mA signal and a contact for each boiler to enable its operation by closing across the Remote Enable contact.

Power supply (120 VAC)

1. See Figure 11 and Figure 12.
2. Connect minimum 14awg copper wire to the power connection as shown in Figure 12.
3. Install a fused service switch, mounted and installed in accordance with all applicable codes.

3

Method 3: External 4-20ma control *(continued)*

4-20mA operation

1. A 4.02 mA current signal will start the boiler, at low fire. A 20mA signal will cause the boiler to go to full input.
2. Between these input signal limits, the boiler modulates. The boiler firing rate percentage is equal to the percentage of the signal between 0 and 20 mA. Example, a signal of 12 mA is 60% of 20 mA, so the boiler firing rate would be 60% of max.
3. In addition to the 4-20mA signal, the remote controller must also close a contact across each boiler's Remote Enable contact in order for the boiler to fire.
4. See Figure 16 for wiring. Notice that the boiler 4-20mA terminals are wired in series.

NOTICE

When using the 4-20 mA input for direct modulation, the maximum modulation the boiler can obtain when first starting is equal to the; **ADVANCED SETUP: MODULAR BOILER: MOD MAX – LAST FIRE.** The timer value **ADVANCED SETUP: MODULAR BOILER: ADD BOILER DELAY** is used in conjunction to limit the modulation for this amount of time. Once the boiler has fired and the **ADD BOILER DELAY** time expires, the full modulation is available. When the boiler is operating under these conditions a blinking * is displayed. This is a protective means for extending the life of the heat exchanger which may consistently be exposed to thermal stress.

IAR (Indoor Air Reset) wiring — apply ONLY if using space heating override mode

- IAR can only be used if one or more of the boilers is wired and piped for override operation. Override would occur when a contact closed across the Heat Demand terminals. While this contact is closed, the boiler will operate based on local control, including feedback for IAR if wired.
- If override operation will be used, and you want to operate with IAR when in override mode, follow the instructions under Method 1 in this manual to wire for IAR.

Sensor wiring

- **Header sensor cannot be used when the boilers are configured for remote operation by a 24-mA source.**
- **Outdoor reset application can be done only in override mode** — To operate with outdoor reset, purchase and install an outdoor sensor. Mount the sensor such that it is shielded from direct sunlight if possible and not likely to be covered by snow drifts or debris. Connect the outdoor sensor leads to the master boiler's electrical connection board as shown in Figure 8. (Member boilers could have their own outdoor sensor if they will be operated in override mode by closing the Heat Demand terminals.)
- **Return water temperature sensor** — The return water temperature sensor is optional, only needed if you want to automatically control the boiler postpurge pump cycle time. Install the sensor in a well in the boiler return piping. Connect the sensor leads to the electrical connection board as shown in Figure 8. Each boiler requires a return water temperature sensor.

- **Sensor wiring, return water sensor** — Firmware Version 2.5 and greater monitors the temperature differential (Delta T) across the heat exchanger. If the Delta T exceeds the setting, the input to the boiler can be optionally limited.

DHW wiring — ONLY if using DHW override mode

- **The boiler (or boilers) must be piped with isolation valves and wired for override operation.** Override of the 4-20mA input will occur if a contact closes across the boiler's DHW Demand terminals.
- To operate the boiler for domestic water heating with a storage tank, install and pipe the tank according to the tank manufacturer's instructions and the recommended piping diagrams in this manual. Consult the factory for applications not covered.
- The circulator used for DHW must be operated by a circulator relay or zone controller that is activated when the tank aquastat calls for heat.
- Connect the tank aquastat terminals across the DHW DEMAND terminals on the master boiler's electrical connection board as shown in Figure 7. (Member boilers could be connected to tank aquastats if they are piped appropriately and intended to operate in override mode.) External interlocks
- 5. Wire external limits and flow switch, when used, as shown in Figure 17.

Overrides — Control priorities

1. The KN control can provide override operation for any or all member boilers. This requires the boilers be piped with appropriate isolation piping and controls.
2. Override is done by closing a contact across the Heat Demand or DHW Demand terminals of any boiler. These priority inputs override all 4-20mA input controls to the boiler.
3. **DHW Demand** — The DHW Demand closure takes priority for ALL boilers, including the master and all members. When DHW Demand closes, the boiler or boilers immediately switch to DHW operation, including setting the water temperature to the DHW Setpoint.
4. **Space heating, Heat Demand** — If any member boiler sees closure across its Heat Demand terminals it will begin operation in space heating mode independently of commands from the 4-20mA input source.

CAUTION

Do not wire boilers for override operation unless the piping design provides automatic isolation of the overriding boilers.

NOTICE

Override operation control setup — Boilers must be set up with operating parameters necessary during their override operation; i.e., local setpoint, DHW setpoint, etc.

5. Summary — priority sequence is:

Priority 1 = DHW Demand

Priority 2 = Heat Demand

Priority 3 = 4-20mA Input/Enable

3

Method 3: External 4-20ma control *(continued)*

Figure 16 KN wiring summary — wiring to electrical connection board

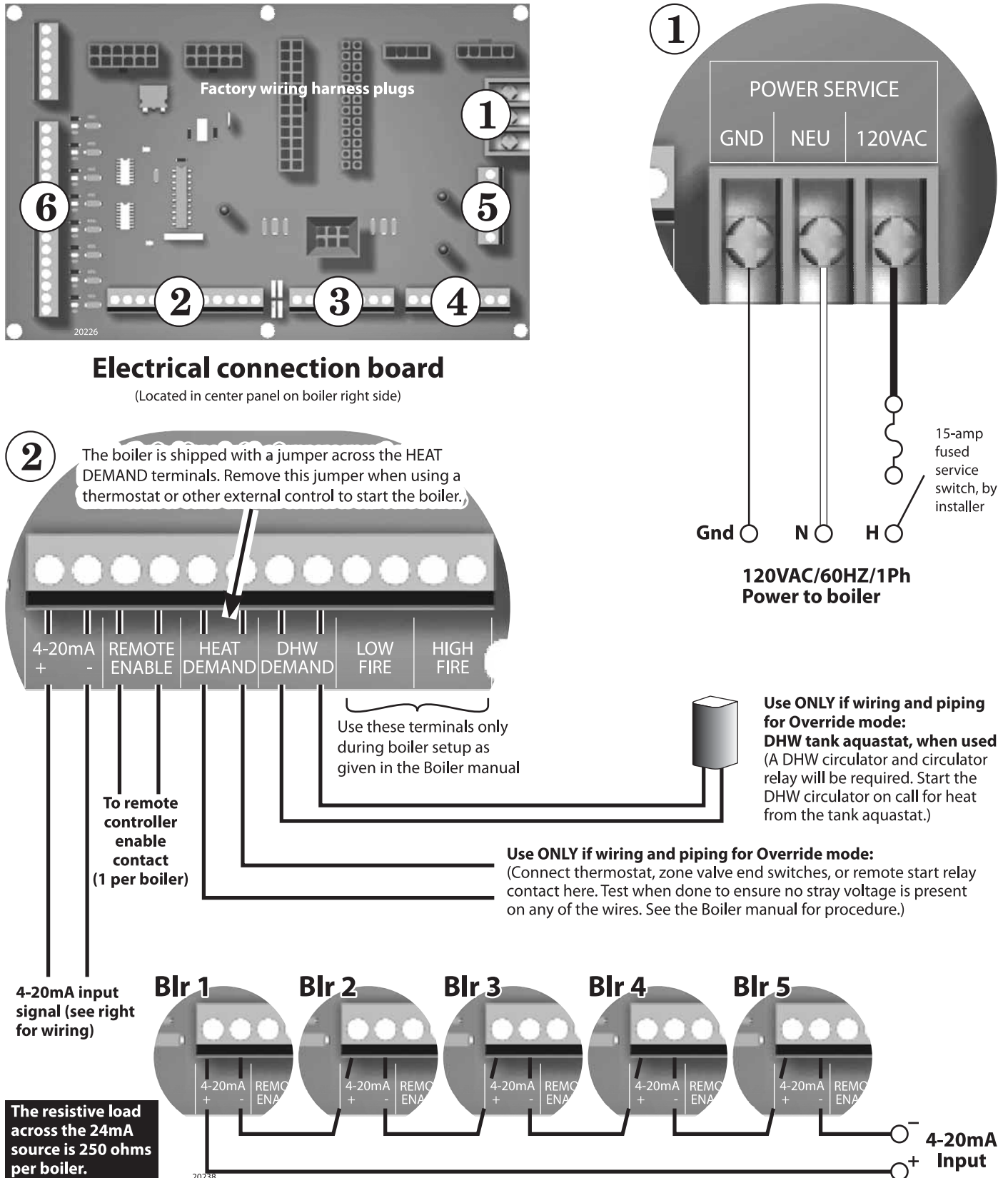

3

Method 3: External 4-20ma control *(continued)*

Figure 17 KN wiring summary — wiring to electrical connection board, continued (see Figure 7 for terminal strip locations)

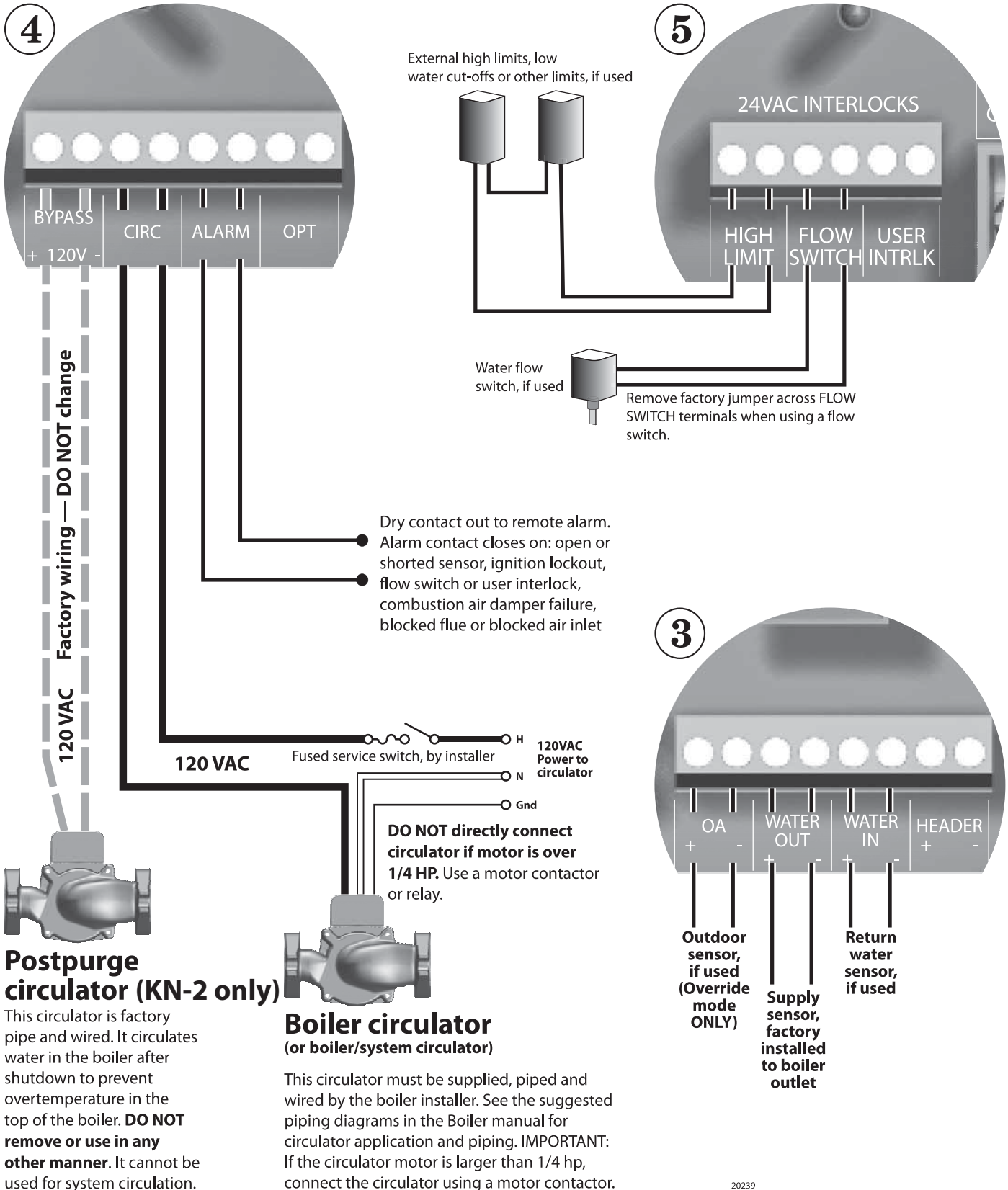

3

Method 3: External 4-20ma control *(continued)*

WARNING Close the external manual gas valve on every boiler before proceeding. DO NOT open any gas valve, or attempt to fire any boiler, until the boilers have been set up and verified following the instructions in the KN Boiler manual.

Failure to comply could cause a boiler failure, leading to possible severe personal injury, death or substantial property damage.

Set control parameters on keypads

NOTICE Before turning boilers on to set parameters, disconnect all call for heat wiring at the electrical connection boards, including the wiring to the boilers' Remote Enable terminals. This will prevent the boiler for attempting to cycle during the setup process.

1. See "Control menus and adjustments," for a complete list of control parameters and explanations.
2. Carefully read the parameter explanations in Table 8.
3. When adjusting the limit band, operating limit (OP LIMIT), local setpoint (LOC SETPOINT) and DHW setpoint, make sure the operating temperature bands do not overlap or cause potential for nuisance cycling.
4. System clock — Set the system clock on all boilers to ensure the time stamps will be accurate in the data logs.
5. Turn on the power to each boiler and set the on/off switch to ON as you set its parameters.
6. Use the boiler's keypad to enter the parameters as described on page 23.
7. After setting a boiler's parameters, turn the power off to the boiler until you are ready to start the boiler up following the Boiler manual instructions.

Start up boilers per KN Boiler manual

1. Turn off power to all boilers.
2. Follow all instructions in the KN Boiler manual to start up each boiler and verify operation.

Start the system

1. Turn off power to all boilers.
2. Connect all call for heat wiring to the boilers.
3. Turn on power to all boilers and turn the on/off switches to ON.
4. The boilers should now operate normally, as described in the Boiler manual.
5. The remote 4-20mA controller will sequence and modulate boilers as necessary to control the water temperature.

Table 6 Control parameters

Parameter	When to set (see notes)
HEAT BAND	Set
LOC SETPOINT	HD only ¹
SOURCE	HD only ¹
DHW SETPOINT	DHW only ²
OP LIMIT	Set
LIMIT BAND	Set
IA RESET	HD only ¹
OA SHUTDOWN	HD or HDOA only ^{1,3}
OA SETPOINT	HD or HDOA only ^{1,3}
OA RESET	HDOA only ³
OA SETPTS	HDOA only ³
DELTA ENABLE	Set if used
DELTA TEMP	Set if used
PURGE TIME	Set if used
ALWAYS ON	Set if used
MASTER PUMP	Set as required
NIGHT SETBACK	HD only ¹
OPTIONS (all)	Set
AUX FUNCTIONS	DO NOT use
SYSTEM CLOCK	Set
LOCAL ADD	DO NOT use
CONSOLE ADD	DO NOT use
MODULAR BOILER	DO NOT use
MODULATION PID	DO NOT use
FIRING MODE	DO NOT use
SENSOR #	HD/HDOA only ^{1,3}
TYPE	HD/HDOA only ^{1,3}
CALIBRATE ?	Only as required
PASSWORD	Set
COMMUNICATIONS	Only as required
LOAD DEFAULTS	Only as required
SYSTEM	Only as required

Notes:

1 — HD Only means to set the parameter for a member boiler only if it is wired for Heat Demand override.

2 — DHW Only means to set the parameter for a member boiler only if it is wired for DHW Demand override.

3 — HDOA Only means to set these parameters only if the member boiler will be operated with outdoor reset when put in override mode with closure across its Heat Demand terminals (requires outdoor sensor connected to boiler).

4

Failsafe Modes

FAILSAFE MODES have been added to help protect systems from loss of heat conditions. When using one of these modes **ensure that you connect any DAMPER control, or system pump control to safely allow operation** with the assumption that the MASTER boiler or BMS system is DOWN.

Failsafe requirements:

1. If the combustion air damper is used as a common system damper, the Failsafe boiler should be wired to control the damper in parallel with the Master boiler. See Figure 9A
2. The Failsafe boiler must have the LOCAL SETPOINT set to the same setpoint temperature as the Master boiler's SYSTEM SETPOINT.

Be aware that the boiler may start without a call-for-heat in the FAILSAFE MODES. FAILSAFE MODES can be accessed through the:

SETUP:AUX FUNCTIONS:FAILSAFE MODES.

The following are types of Failsafe conditions.

1. Building Management System Failure (Master Boiler Only)

If a BMS system is controlling the setpoint and enabling the boiler system, a timer is provided to allow operation of the system in the event that communications are lost with the BMS system. The HeatNet boiler system will run locally if communications is lost and this timer expires due to the lack of being updated.

The system setpoint timer and system setpoint work in tandem to externally control (i.e. a BMS - building management system) the operating setpoint. The setpoint (countdown) timer should be loaded with a timeout value (in seconds) prior to writing the system setpoint. When the timer reaches zero, the control assumes that the BMS is no longer operating and the local setpoint (saved on the control) is reloaded. If the setpoint timer is not written, a default timeout value of 60 seconds is assumed. The timer is automatically reloaded with the default value when a setpoint is written.

2. HeatNet Communications Lost

SETUP:AUX FUNCTIONS:FAILSAFE MODES: H-NET COMM LOST:

This mode allows a member boiler to run in LOCAL if the communications link via the H-NET cable is lost. This includes the MASTER boiler losing its Control board, Communications board, or the power on the MASTER is switched OFF. When this MODE is set to ON, and if the member boiler loses its link (heartbeat packet over the H-NET cable) to the MASTER Boiler, this MEMBER will fire to the LOCAL setpoint.

NOTICE

Failsafe boilers can be used to attempt to prevent deadheading system pumps by opening their local valves in the event the master control goes down. If the failsafe member boiler has its Master Pump setting set to ON and it does not see communication from the master for 30 seconds, it will energize its local pump /valve contacts.

NOTICE

If the Master Pump setting is not set to ON, then the control will wait 10 minutes after losing communications with the HeatNet master before switching to local operation.

This MEMBER boiler will continue to run at the LOCAL setpoint until H-NET communications from the MASTER boiler is re-established.

Ensure that this Member boiler's Damper and The System pump control are configured correctly with the assumption that the Master is not powered. Also ensure that any other System settings related to outside air temperature sensing and system interlocks are set to provide safe operation.

3. Low Temperature Protection

LOW TEMP: OFF, SUPPLY, HEADER, or RETURN

This mode may be used by the MASTER or MEMBER boiler and can be used as a type of freeze protection. In this mode you may select which Sensor you wish to monitor, or you may opt to turn this mode OFF. If you select a sensor, you may then associate it with a temperature at which the boiler will turn ON. Once the temperature at this sensor falls below the LOW TEMP temperature the boiler will start and fire to its LOCAL setpoint. Once the Boiler reaches its setpoint it will turn OFF.

5

Control menus and adjustments

The Heat Net control display

Starting the display

1. Check all wiring to make sure it is complete and all wires are securely connected.
2. Verify that the HEAT DEMAND and DHW DEMAND wires are removed.
3. Close the external gas valve on every boiler.
4. Turn on power to the boiler and then turn the boiler on/off switch ON.
5. The control will beep at least twice and the display will show the first STANDBY display in Figure 18. Note that pushing the DOWN button on the keypad will change the right side of the display as shown, providing information on various setpoints and parameters.
6. The display, LOC SET, means the setpoint temperature. Figure 18 shows the factory default values.

Accessing setup menus

1. With the display in STANDBY, press and hold the BACK key for 5 seconds.
2. The display will change to:

```
> SETUP
  VIEW LOG
```

3. Press the SELECT key to select setup. (Note that pressing the DOWN key would change the selection to VIEW LOG.)
4. The display will now show the first options in the setup menus:

```
> KN    U XX
  BOILERS
```

5. Press the DOWN key to access additional menu options. Pressing the DOWN button once will change the display to:

```
KN    U XX
> BOILERS
```

6. The cursor moves to the second line, indicating this option could now be selected with the SELECT key.
7. Continuing to press the DOWN key will access these menu options:
 - **BOILERS**
 - **SETPOINTS**
 - **INDOOR AIR**
 - **PUMP OPTIONS**
 - **NIGHT SETBACK**
 - **OPTIONS**
 - **LOG/RUNTIME**
 - **AUX FUNCTIONS**
 - **SYSTEM CLOCK**
 - **ADVANCED SETUP**

Figure 18 Heat Net display during Standby (no call for heat) — pressing the DOWN key on the keypad changes the display as shown

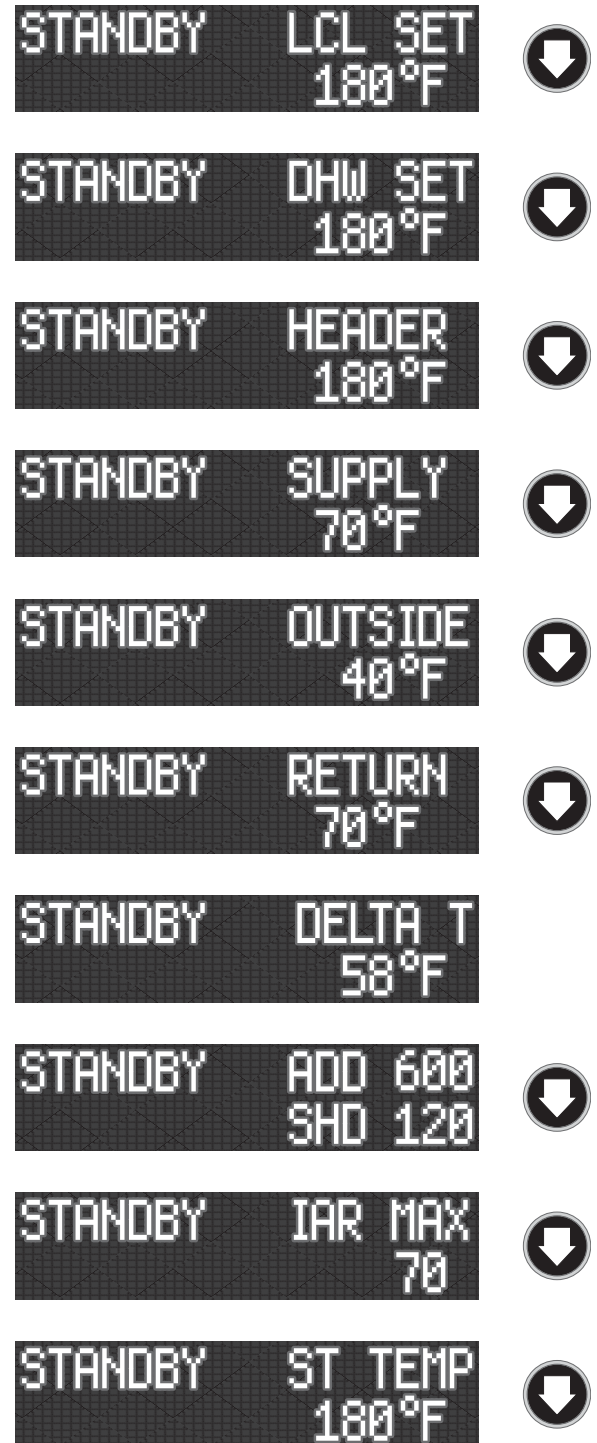













5

Control menus and adjustments *(continued)***Table 7** Setup menus (see Table 8 for explanations)

To enter Setup: From STANDBY, hold  for 5 seconds. Then press  with cursor on SETUP. Make sure there is no call for heat at the boiler before attempting to perform setup adjustments.

To return to STANDBY, press/release  until the display returns to standby, or turn boiler ON/OFF switch off, then on.

Level 1  next item  to select	Level 2  next item  to select  back one level	Level 3  next item  to select  back one level	Level 4  next item  to select  back one level	Default {Range}  to change value  to accept value and return to previous menu level	Typical line (Display shows two lines at a time; cursor indicates active line)	
KN-2 V.X.X				Shows firmware version number	KN-2 V.X.X	
BOILERS	# BOILERS			1 {1 to 16} — display only	# BOILERS 1	
	LEAD BOILER			1 — display only — the lead boiler is the boiler with a HEADER sensor connected	LEAD BOILER 1	
	HEAT BAND			30 °F {2 to 50°F}	HEAT BAND 30°F	
	HEAT NET BOILERS 123456789012345			Display only, on MASTER boiler only — shows the H-NET ADDRESS of each boiler detected on the HeatNet network (from 1 to 16) NOTE that the MASTER address, actually 255, is shown as M in this display	HEAT NET BOILERS 123456	
SETPOINTS	LOC SETPT			180°F {40 to 220°F}	LOC SETPT 180°F	
	SOURCE			AUTO {AUTO, 4-20MA}	SOURCE AUTO	
	DHW SETPT			180°F {140 to 220°F}	DHW SETPT 180°F	
	OP LIMIT			205°F {45 to 230°F}	OP LIMIT 215°F	
	LIMIT BAND			10°F {1 to 50°F}	LIMIT BAND 20°F	
INDOOR AIR	IA RESET			OFF {OFF or NEEDIEST or AVERAGE or SPECIFIC}	IA RESET OFF	
	ACTIVE ZONES			8 {1 to 8}	ACTIVE ZONE 8	
	SPECIFIC ZONE			1 {1 to ACTIVE ZONES}	SPECIFIC ZONE 1	
	IAR TIME			60 MIN {30 to 120 minutes}	IAR TIME 60MIN	
	SET IAR SETPTS	DELTA TEMP @ HI IAR%			10°F {10 to 20°F} 70% {40 to 70%}	DELTA TEMP 10°F @ HI IAR% 70%
		DELTA TEMP @ LO IAR%			20°F {10 to 20°F} 40% {40 to 70%}	DELTA TEMP 20°F @ LO IAR% 40%
VIEW IAR VALUES			Display only, not changeable here — shows values for 8 zones	70 70 70 70 70 70 70 70		
OUTDOOR AIR	OA SHUTDOWN			OFF {ON or OFF}	OA SHUTDOWN OFF	
	OA SETPT			68°F {40 to 100°F}	OA SETPT 68°F	
	OA RESET			OFF {ON or OFF}	OA RESET OFF	
	SET OA SETPTS	LOW WATER @ HI OA			140°F {60 to 190°F} 70°F {50 to 90°F}	LOW WATER 140°F @ HI OA 70°F
		HI WATER @ LOW OA			180°F {70 to 220°F} 10°F {-35 to +40°F}	HI WATER 180°F @ LOW OA 10°F
PUMP OPTIONS	FLOW PROVE			10s {10- 240s}	FLOW PROVE 10s	
	DELTA ENAB			OFF {ON or OFF}	DELTA ENAB OFF	
	DELTA TEMP			10°F {10 to 50°F}	DELTA TEMP 10°F	
	PURGE TIME			0m {0 – 60m}	PURGE TIME 0M	
	ALWAYS ON			NO {YES or NO}	ALWAYS ON NO	
	MASTER PUMP			OFF {ON or OFF}	MASTER PUMP OFF	
	DHW PRIOR - KN2 ONLY			OFF {OFF or ON}	DHW PRIOR OFF	
	DHW PUMP - KN4 ONLY			N/A {NA or ENABLE or PRIOR or MULTI}	DHW PUMP N/A	





5

Control menus and adjustments *(continued)***Table 7** Setup menus *(see Table 8 for explanations)* *(continued)*

NIGHT SETBACK	SETBACK # X			1 {1 through 4}	SETBACK # 2	
	ENTRY IS OFF	SETBACK		20°F {0 to 50°F}	ENTRY IS OFF	
		ST DAY		SUN {SUN, MON, TUE, WED, THU, FRI, SAT}	ST DAY THU	
		ST TIME		12:00AM	ST TIME 3:00PM	
		ENDDAY		SUN {SUN, MON, TUE, WED, THU, FRI, SAT}	ENDDAY SAT	
	ENDTIME		12:00AM	ENDTIME 10:00PM		
OPTIONS	TEMP SCALE			°F {°F or °C}	TEMP SCALE °F	
	KEY CLICK			ON {ON or OFF}	KEY CLICK ON	
	SKIP PASSW			ON {ON or OFF}	SKIP PASSW ON	
	BRIGHTNESS			50% {12, 25, 37, 50, 62, 75, 87, 100%}	BRIGHTNESS 50%	
	ALARM SOUND			OFF {OFF or ON}	ALARM SOUND OFF	
LOG/RUNTIME	RUN HRS			Total time gas valve has been open	RUN HRS 1240	
	LOG ENTRY			Current entry in the log (see Table 9, page 30)	LOG ENTRY 327	
	SIZE			The size of the data log	SIZE 1000	
	BOILER CYC			Number of times gas valve has been cycled on/off	BOILER CYC 5021	
AUX FUNCTIONS	COMBUST DAMPER	CAD IN USE?		YES {YES or NO}	COMBUST DAMPER IN USE? YES	
	PROOF TIME			2:00 {0:00 to 4:00min}	PROOF TIME 2:00	
	DHW SENSOR			NO {NO or YES}	DHW SENSOR NO	
	DHW PROTECTION			OFF {OFF, 60, 90, 120min}	DHW PROTECTION OFF	
	DHW CYCLE MAX	IN USE?		NO {YES or NO}	DHW CYCLE MAX IN USE? YES	
	FAIL SAFE MODE	BMS LOST			OFF {OFF or ON}	FAIL SAFE MODE OFF
		H-NET LOST			OFF {OFF or ON}	
		LOW TEMP			OFF {OFF or SUPPLY or RETURN or HEADER}	
		TEMP SET<			40°F {35 to 180°F}	
	IGN DELAY TIME			0:00 {0:00 to 15:00min}	IGN TIME 0	
	EXTENDED PURGE			0:00 {0:00 to 10:00min}	EXT. PURGE 0	
HEAT EXCHANGER	DELTA T			60°F {1 to 100°F}	HEAT EXCHANGER	
SYSTEM CLOCK	TIME			12:00AM	TIME 11:20AM	
	DAY OF WEEK			SUN	DAY OF WEEK MON	
	MONTH			SEP	MONTH JAN	
	DAY			12	DAY FRI	
	YEAR			2007	YEAR 2007	

5

Control menus and adjustments *(continued)*Table 7 Setup menus *(see Table 8 for explanations)* *(continued)*

ADVANCED SETUP	DISTRIB CTRL	CONTROL	HNET	CONTROL	HNET
		HNET MASTER		YES (Display only, not changeable here)	HNET MASTER
	LOCAL ADD		Master default = 255 (not changeable) Member default = 2 (Range = 2 to 16)	LOCAL ADD	255
	CONSOLE ADD		Default = 1; Range = 1 to 247	CONSOLE ADD	255
	MODULAR BOILER	ADD BOILER DLY	10 minutes {0 to 15 minutes}	> 10 MINUTES	0 SECONDS
		SHED BOILER DLY	2 minutes {0 to 15 minutes}	> 2 MINUTES	0 SECONDS
		MOD DELAY TIME	0:00 {0:00 to 60:00min}	> 0 MINUTES	0 SECONDS
		MOD MAX - LAST	50% {20 to 100%}	STOP MOD MAX	> % 50
		STOP BAND OFFSET	5°F {0 to 50°F}	EARLY STOP	> 5°
		BLR START TIME	40s {0 to 4min}	> 0 MINUTES	40 SECONDS
	ADAPTIVE MODE (Adjustable on Master only)	ADAPTIVE	ON {OFF or ON}	ADAPTIVE	ON
		ADJUST	ON IGN {ON IGN or ON CALL}	ADJUST	ON IGN
		HOLD TIME	0s {0 to 600s}	HOLD TIME	0
	FIRING MODE	ROTATION	TRUE {True, FOFO, LOFO}	ROTATION	TRUE
		MASTER 1ST	OFF	MASTER 1ST	OFF
	SENSORS	SENSOR#	OUTSIDE	SENSOR#	SUPPLY
		TYPE	TYPEZ {TYPEZ, None, ON/OFF}	TYPE	TYPEZ
		CALIBRATE ?	NO {YES or NO}	CALIBRATE ?	NO
	4-20mA input	4mA SET	50°F {50 to 220°F} (Not applied unless SETPOINT SOURCE is set to 4-20mA)	4mA SET	50°F
		20mA SET	180°F {50 to 200°F} (Not Applied unless SETPOINT SOURCE is set to 4-20mA)	20mA SET	220°F
		START	4.11mA {3.7 to 4.3mA} (Applies to either 4-20mA setpoint or modulation)	START	4.11mA
		PRIORITY	Default = NORMAL {NORMAL or HIGH} NOTE: HIGH will cause the 4-20mA input to take control when a contact closes across the 4-20mA ENABLE terminals. To set to HIGH, make sure SETUP SETPOINTS SETPOINT SOURCE is set to AUTO.	PRIORITY	NORMAL
	PASSWORD	CHANGE PASSWORD OLD:>? _____	Press  , enter old password using arrow keys and  for each character	CHANGE PASSWORD OLD:>? _____	
		CHANGE PASSWORD NEW:>? _____	Press  , enter new password using arrow keys and  for each character	CHANGE PASSWORD NEW:>? _____	
		ACCEPT >	YES / YES or NO	CHANGE PASSWORD ACCEPT	>YES
	COMMUNICATIONS	BAUD	19200 {1200 or 2400 or 4800 or, 9600 or 19200 or 38400}	BAUD	19200
		FORMAT	8E1 {8E1, 8N1, 8N2, 8O1}	FORMAT	8E1
		SETPT TIMER	ON {ON or OFF}	SETPT TMR	ON
	LOAD DEFAULTS	FACTORY CAL?	NO {YES or NO}	FACTORY CAL?	NO
			ARE YOU SURE>	ARE YOU SURE>	NO
		FACTORY SET?	NO {YES or NO}	FACTORY SET?	NO
			ARE YOU SURE>	ARE YOU SURE>	NO
	SYSTEM	UPDATE CTRL?	ARE YOU SURE>	UPDATE CTRL?	
		PRIORITY SET	2 {2 or 1}	PRIORITY SET	2

5

Control menus and adjustments *(continued)*

Table 8 Setup menus — parameter explanations

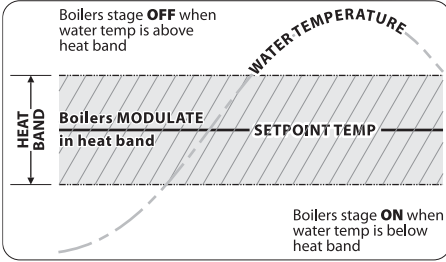
Menu item	Under . . .	Explanation
FIRMWARE VERSION	VX.X	All boilers in a multiple boiler application should preferably have the same firmware version to ensure consistency. If versions are different, they must all have the same first digit in the version number (i.e., 2.x).
HEATNET BOILERS	BOILERS	This line appears on the display only for a HeatNet Master boiler (boiler with a sensor connected to the SYSTEM HEADER sensor input terminals). The line is <i>blank</i> on MEMBER boilers. If the number of boilers shown is less than the number of boilers on the HeatNet network, check the yellow light on the HeatNet connection port of each boiler. The yellow light will be flashing, indicating network traffic, if the communications port is successfully connected to the Master. The address of each recognized MEMBER boilers (addresses 2 up to 16), and begins with "M," the address of the Master boiler
HEAT BAND	BOILERS	 <p>The heat band is the height of the modulating band. When the water temperature is between ½ the heat band above or below the setpoint temperature, boiler firing rate modulates. Boilers are at minimum input at the upper end of the band and maximum input at the lower end of the band. Boilers come on only if the water temperature is below the band. Boilers stage off when the water temperature is above the band.</p>
LOC SETPT	SETPOINTS	Setpoint temperature controlled by the KN control. NOTE: If the control is operated by a Master control or by a remote control (building management system, 4-20ma control, etc.), this setpoint temperature only comes into play when the KN-2 control is in override mode (such as by closing its Heat Demand or DHW Demand terminals).
SOURCE	SETPOINTS	Specifies where the space heating setpoint temperature comes from: AUTO: With AUTO selected, the HeatNet control determines the setpoint (using local setpoint, outdoor reset or SYS/DHW HEADER temperature setpoint). 4-20mA: If 4-20mA is selected, the HeatNet control determines setpoint based on the signal it receives at the 4-20mA terminals on the connection board. There must be a contact closure across REMOTE ENABLE terminals (J9) for the boiler to respond to the 4-20mA signal. The temperature and boiler start settings are set in the ADVANCED SETUP 4-20mA INPUT menus. (The menu will automatically transfer to the 4-20mA INPUT menu if 4-20mA is selected for SETPOINT SOURCE.) If the HEAT DEMAND input is closed, the H-NET control will use the SYSTEM SETPT or LOCAL SETPT temperature to control the boiler(s) if the 4-20mA signal is below 5mA. Once the current exceeds 5mA, the setpoint is determined from the mA signal value. (This method may be thought of as a backup in the event the 4-20mA signal is lost.) If the HEAT DEMAND input is open, the 4-20mA signal will start the H-NET system once the current exceeds 5mA. Temperature is controlled to the setpoint determined by the milliamp signal value.
DHW SETPT	SETPOINTS	This is the setpoint temperature for the boiler outlet water (or header water temperature) when the DHW Demand terminals see a closed contact (DHW tank temperature control calls for heat, for example).

5

Control menus and adjustments *(continued)*

Table 8 Setup menus — parameter explanations (continued)

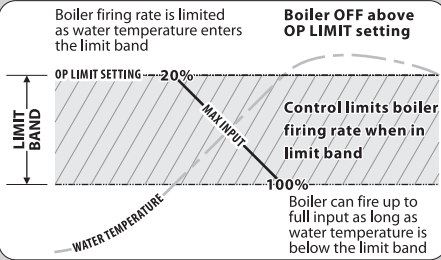
Menu item	Under . . .	Explanation
OP LIMIT	SETPOINTS	<p>This is the temperature at the boiler outlet (or header sensor) that will cause the control to shut down on high temperature limit. It must be high enough above the upper end of the heat band to avoid nuisance cycling.</p> <p>The maximum setting is 205°F.</p> <p>Example: If the boiler setpoint is 180°F, and the heat band is 30°F, the upper end of the heat band is $180 + 30/2 = 195^\circ\text{F}$. The limit band (see below) must be set at 10°F so the OP LIMIT setting can be: $195 + 10 = 205^\circ\text{F}$ (maximum allowable setting).</p> <p>The operating limit setting (OP LIMIT) always limits boiler outlet water temperature, regardless of how the boiler is controlled (HeatNet member, 4-20ma control or stand-alone). The limit band (see below) determines when the boiler begins to be forced to reduce input as the outlet temperature rises toward the limit setting.</p>
LIMIT BAND	SETPOINTS	 <p>If the boiler outlet water temperature rises toward the limit setting (OP LIMIT, above), the KN control will begin to reduce the boiler's firing rate when the temperature gets within the LIMIT BAND degrees F below the operating limit setting. At the lower end of the limit band, the boiler can fire up to maximum input (100%). By the time the temperature reaches the upper end of the band (the OP LIMIT setting), the boiler is limited to minimum input (20%).</p> <p>The limit band reduces the likelihood of short cycling on boilers controlled by a master control or a remote control by reducing boiler maximum allowable firing rate as the temperature rises toward the limit setting. Make sure the lower end of the limit band is above the upper end of the heat band.</p>
IA RESET	INDOOR AIR	<p>Enable Indoor Reset by setting this to one of the following possible modes:</p> <p>NEEDITEST: The boiler's maximum fire rate will be determined by the zone with the largest load,</p> <p>AVERAGE: The boiler's maximum fire rate will be determined by the average load of the ACTIVE ZONES.</p> <p>SPECIFIC: The boiler's maximum fire rate will be determined by the load of the SPECIFIC ZONE.</p>
	ACTIVE ZONES	<p>The number of zones to be used to determine the boiler's maximum fire rate when using Indoor Air Reset in AVERAGE Mode. The zones in use always starts at 1; example an ACTIVE ZONES value of 5 will use zones 1, 2, 3, 4, and 5 to determine the boiler's maximum input.</p>
	SPECIFIC ZONE	<p>The zone which will be used to determine the boiler's maximum firing rate when using Indoor Air Reset in SPECIFIC mode.</p>
AVG TIME	INDOOR AIR	<p>The averaging time (AVG TIME) is the time span over which the control averages the results of zone demands. Leave this setting at the factory default unless directly otherwise by HydroTherm Technical Support.</p>
SET IAR SETPTS	INDOOR AIR	<p>Leave the delta temp settings at factory default settings unless directed otherwise by HydroTherm Technical Support. The determine how much the control adjusts maximum allowable firing rate based on its monitoring of zone demand.</p>
OA SHUTDOWN	OUTDOOR AIR	<p>When outdoor air shutdown is enabled (ON), the boiler and its circulating pump shut down when the outside temperature is above the outdoor air setpoint (OA SETPT). This requires an outdoor sensor when enabled.</p>
OA SETPT	OUTDOOR AIR	<p>The boiler and its circulator shut down when the outside air temperature is above this setting if outdoor air shutdown is enabled (ON). This requires an outdoor sensor when enabled.</p>

5

Control menus and adjustments *(continued)***Table 8** Setup menus — parameter explanations (continued)

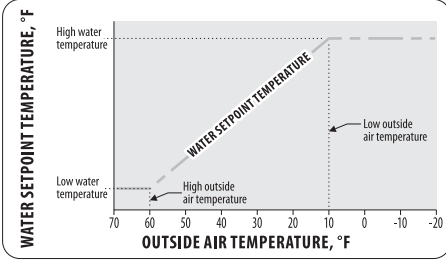
Menu item	Under . . .	Explanation
OA RESET	OUTDOOR AIR	Set to "ON" to enable resetting the boiler outlet temperature (or header temperature) based on outside air temperature. Set to "OFF" to disable outdoor reset. This requires an outdoor sensor when enabled.
LOW WATER @ HI OA HI WATER @ LOW OA	OUTDOOR AIR SET OA SETPTS	 <p>These temperatures determine the reset curve for supply water temperature. High water at low outside air means the design water temperature for maximum load (at ODT, or outside design temperature for the installation). The other end of the reset curve is the low water temperature at high outside air temperature. The low water temperature is generally equal to room temperature, meaning no heat input to the space would occur below this outside air temperature.</p>
DELTA ENABLE	PUMP OPTIONS	The boiler pump can be set to run after boiler shutdown to distribute residual heat to the heating system. Delta enable causes the boiler pump to run until the temperature difference between boiler inlet and outlet is less than DELTA TEMP (see below). The pump will continue to run an additional period after this for the amount of time specified in PURGE TIME (below).
DELTA TEMP	PUMP OPTIONS	When DELTA ENABLE (above) is set to "ON," the boiler pump will run until the temperature difference across the boiler is less than DELTA TEMP. (The pump will run an additional time equal to the PURGE TIME.) An inlet temperature sensor is required.
PURGE TIME	PUMP OPTIONS	The boiler pump can run after boiler shutdown to distribute heat remaining in the boiler water. PURGE TIME sets how long the boiler pump will run. (Also see DELTA TEMP, above.) NOTICE: For systems that shut off flow valves (such as zone valve systems) when the call for heat is satisfied, this option must be set to "0" to prevent dead-heading the pump.
ALWAYS ON	PUMP OPTIONS	If ALWAYS ON is set to "YES," the boiler circulator never turns off.
MASTER PUMP	PUMP OPTIONS	If set to "ON," the master control in the network will keep its pump contacts closed (running its pump and/or control valve) if no other boilers are operating. This is used to prevent dead-heading system flow. NOTE: See H-NET LOST Failsafe description for MASTER PUMP failsafe on member boiler
DHW PRIOR *KN2 ONLY	PUMP OPTIONS	If set to "ON" the boiler's local circulator will be de-energized on all DHW calls.
DHW PUMP *KN4 ONLY	PUMP OPTIONS	If set to "N/A" the boiler's local circulator will be energized for all heat demands, including DHW. If set to "ENABLE" the local circulator will be used on all heat demands EXCEPT DHW demands, and the BYPASS contacts will be used to energize a DHW pump for DHW demands. No Priority is given, if there is a DHW demand AND a Heat Demand then both pumps would be active. If set to "PRIOR" the local circulator will be used on all heat demands EXCEPT DHW demands, and the BYPASS contacts will be used to energize a DHW pump for DHW demands. Priority is given to DHW demands, if there is a DHW demand AND a Heat Demand then only the BYPASS contacts would be enabled. If set to "MULTI" the local circulator will be used on all heat demands EXCEPT DHW demands, and the BYPASS contacts and the local circulator will be energized for DHW demands. NOTE: The Bypass contacts will have a 2 minute post purge time for the DHW pump.
SETBACK#	NIGHT SETBACK	Setback number is the designator for the setback operation. Up to four (4) setback operations can be programmed.

5

Control menus and adjustments *(continued)***Table 8** Setup menus — parameter explanations (continued)

Menu item	Under . . .	Explanation
ENTRY IS	NIGHT SETBACK	Select "ON" to enable a setback operation. Then program the times, days and setpoint. The setpoint assigned will override the KN control's setpoint when setpoint is controlled locally. It will not override 4-20ma control or building management control.
TEMP SCALE	OPTIONS	Select Fahrenheit or Centigrade.
KEY CLICK	OPTIONS	If activated, the control beeps when a key is pressed.
SKIP PASSW	OPTIONS	The control can be programmed such that a password is required to change settings. Setting this to "ON" disables the password.
BRIGHTNESS	OPTIONS	Adjust the brightness of the display.
ALARM SOND	OPTIONS	If set to "OFF" the audible alarm will not be used to annunciate faults.
RUN HRS	LOG/RUNTIME	Displays the total time the boiler gas valve has been open.
LOG ENTRY	LOG/RUNTIME	Displays the current entry in the data log (see Table 9, page 30).
SIZE	LOG/RUNTIME	Displays the current number of entries in the data log.
BOILER CYC	LOG/RUNTIME	Displays the number of times the boiler gas valve has been cycled on, then off. It does not include failed ignition attempts.
COMB AIR DMPR IN USE?	AUX FUNCTIONS	Select "YES" to connect a combustion air damper and its end switch to the electrical connection board.
PROOF TIME	AUX FUNCTIONS	Set proof time long enough to be sure the combustion air damper can open and activate its end switch.
DHW SENSOR	AUX FUNCTIONS	Select "YES" to have the control maintain the DHW SETPOINT value at the RETURN water sensor location for all DHW Demands. This allows the HEADER sensor to be located in the Heating loop, and a separate DHW sensor to be located in the DHW loop. This is useful for a MASTER boiler to be able to use members for Heating or DHW when a HEADER sensor is located outside the DHW loop. NOTE: When this feature is enabled ALL Delta T features using RETURN sensor are DISABLED, and the temperature is reported as DHW instead of RETURN on the Home screen. NOTE: When used in this way the sensor must be moved to a position where it will sense the temperature of the water being supplied to the tank.
DHW PROTECTION	AUX FUNCTIONS	If in use the control will alarm and disable the DHW demand input if a DHW demand lasts for more than the selected time.
DHW CYCLE MAX	AUX FUNCTIONS	If set to "ON", when a DHW demand is satisfied, and there is still a heat demand preset, and the supply temperature is above the heating band, the boiler will continue to fire a minimum input until the supply temperature drops back into the band, or the heat demand is satisfied. This is useful when running a lower temperature LCL Setpoint with a higher DHW setpoint.

5

Control menus and adjustments *(continued)***Table 8** Setup menus — parameter explanations (continued)

Menu item	Under . . .	Explanation
BMS LOST MASTER BOILERS ONLY	AUX FUNCTIONS FAIL SAFE MODE	When set to NO, the boiler/system will only operate if activated by an override input (HD, DHW, 4-20mA, LOW FIRE or HIGH FIRE) When set to YES, the Master boiler will revert to LOCAL operation, controlling its Header water temperature to the LOCAL SETPOINT setting. NOTE: The control will wait 10 minutes after losing communications with the BMS before switching to local operation. NOTE: If a Combustion Air Damper is in use make sure the Fail Safe boiler is able to open and prove the damper.
H-NET LOST	AUX FUNCTIONS FAIL SAFE MODE	When set to NO, the boiler will only operate if activated by an override input (HD, DHW, 4-20mA, LOW FIRE or HIGH FIRE) When set to YES, the boiler will revert to LOCAL operation, controlling its Supply water temperature to the LOCAL SETPOINT setting. The LOCAL PUMP relay will remain ON during failsafe operation. NOTE: Failsafe boilers can be used to attempt to prevent deadheading system pumps by opening their local valves in the event the master control goes down. If the failsafe member boiler has its Master Pump setting to ON and it does not see communication from the master for 30 seconds, it will energize its local pump/valve contacts. NOTE: If the Master Pump setting is not set to ON, then the control will wait 10 minutes after losing communications with the HeatNet master before switching to local operation. NOTE: If a Combustion Air Damper is in use make sure the Fail Safe boiler is able to open and prove the damper.
LOW TEMP	AUX FUNCTIONS FAIL SAFE MODE	This function can automatically start the boiler (or boilers, via the Master) if water temperature drops below the value set in TEMPSET <. This function can be used to provide automatic freeze protection. The LOCAL PUMP relay will be set to always ON during failsafe operation. Once the boiler setpoint temperature is reached, the boiler (or boilers) will shut off. Select which sensor to monitor: SUPPLY, RETURN or HEADER. NOTE: If a Combustion Air Damper is in use make sure the Fail Safe boiler is able to open and prove the damper.
TEMP SET <	AUX FUNCTIONS FAIL SAFE MODE	Set the minimum allowable temperature for the location selected in LOW TEMP, above. NOTE: If a Combustion Air Damper is in use make sure the Fail Safe boiler is able to open and prove the damper.
IGN DELAY TIME	AUX FUNCTIONS	This is the amount of time that a HEAT DEMAND must be present before the boiler is allowed to fire. The circulator pumps will come on normally, only the boiler ignition will be delayed.
EXTENDED PURGE	AUX FUNCTIONS	This is the amount of time the fan post purge can be extended from the required 10 seconds. A demand during the extended purge will end the purge cycle and allow the boiler to fire and handle the demand.
DELTA T	AUX FUNCTIONS HEAT EXCHANGER	This is the maximum differential temperature the heat exchanger can see before the LIMIT RATE feature is activated, and a log entry is made.
SYSTEM CLOCK		Set the system clock (time, day of week, month, day and year) on start-up and after any power outage to ensure the data log time stamp information will be accurate.
LOCAL ADD	ADVANCED SETUP DISTRIB CTRL	Assign each member boiler a unique address, beginning with "2" or higher. Enter any value from 2 to 16. The master boiler local address is automatically set to 255. (The master boiler is automatically recognized because it is the one with a header sensor wired to its HEADER SENSOR terminals.)
CONSOLE ADD	ADVANCED SETUP DISTRIB CTRL	This is used only when the boilers are regulated by a building management system, using MODBUS, BACNET or LONWORKS. Assign each member boiler AND the Heat Net master boiler a unique address, an value from 1 to 247.

5

Control menus and adjustments *(continued)***Table 8** Setup menus — parameter explanations (continued)

Menu item	Under . . .	Explanation
ADD BOILER DLY	ADVANCED SETUP MODULAR BOILER	This is the minimum wait time before an additional boiler can fire when called on by the master boiler control. This time is also used to limit the maximum modulation the boiler can obtain when first starting in response to a 4-20mA , or High Fire Demand.
SHED BOILER DLY	ADVANCED SETUP MODULAR BOILER	This is the minimum wait time before a boiler can shut down by the master boiler control.
MOD DELAY TIME	ADVANCED SETUP MODULAR BOILER	The boiler will remain at minimum fire when first starting until this amount of time has elapsed.
MOD MAX-LAST	ADVANCED SETUP MODULAR BOILER	This sets the maximum firing percentage for boilers during times that some boilers are not firing. It limits input of the boilers to keep them as efficient as possible. Once all boilers are started (during high heat demand periods), this limit is remove, and all boilers can fire up to maximum input. Once any boiler is dropped offline, the limit is applied again. This value is also used as the maximum modulation the boiler can obtain when first starting in response to a 4-20mA , or High Fire Demand.
STOP BAND OFFSET	ADVANCED SETUP MODULAR BOILER	This setting helps reduce short-cycling when water temperature is within the heat band. If the water temperature rises to the top of the heat band less the STOP BAND OFFSET before a boiler just added has completed its modulation delay time, the boiler will shut down. Example, if the top of the heat band is 190°F and stop band offset is 15°F, a newly-added boiler will shut down if the temperature reaches 175°F (190 - 15) before its modulation delay time has ended.
BLR START TIME	ADVANCED SETUP MODULAR BOILER	DO NOT CHANGE — This is the time from receiving a call for heat to when a boiler begins its modulation operation (running at minimum fire).
ADAPTIVE	ADVANCED ADAPTIVE MODE	ON — the Master boiler lowers the modulation rate of all currently-operating boilers before a newly-added boiler enters "run" state. After the new boiler starts, the Master boiler waits the DELAY RELEASE time (see below) before allowing return to normal modulation. OFF — the Master boiler allows the HeatNet system to modulate normally as additional boilers start.
ADJUST	ADVANCED ADAPTIVE MODE	ON IGN — the Master boiler (ADAPTIVE is ON) waits until the newly-added boiler reaches its run state before lowering the modulation rate of running boilers. ON CALL — the Master boiler (ADAPTIVE is ON) drops the modulating rate of running boilers immediately when an additional boiler is called.
HOLD TIME	ADVANCED ADAPTIVE MODE	When ADAPTIVE is ON, the Master boiler waits this amount of time before allowing the system to return to normal modulation. This delay allows time for the newly added heat to impact the system.
ROTATION	ADVANCED SETUP FIRING MODE	Select the rotation method. True rotation attempts to fire all boilers an equal amount of time. First on/first off jogs between boilers to balance usage. Last on/first off maintains the same rotation sequence at all times.
MASTER 1ST	ADVANCED SETUP FIRING MODE	Set this to "ON" to always start the master boiler first, regardless of the rotation scheme selected.
SENSOR#	ADVANCED SETUP SENSORS	There are up to three sensors: OUTSIDE, HEADER and RETURN.
TYPE	ADVANCED SETUP SENSORS	Type Z is for a thermistors sensor (as supplied). "None" means do not use this sensor. ON/OFF looks for an external dry contact closure.

5

Control menus and adjustments *(continued)***Table 8** Setup menus — parameter explanations (continued)

Menu item	Under . . .	Explanation
CALIBRATE ?	ADVANCED SETUP SENSORS	Use this function only if the response to a sensor indicates the control calibration may be off. Calibrate the control by attaching a 10k precision resistor across the sensor terminals. Select "YES" after "CALIBRATE?" The control will measure the resistance and establish a trim value (in ohms) for the sensor input. The control display will show the trim value setting. The trim value must not exceed +/- 200 ohms. If it does, verify that the resistor is correctly connected. If so, the sensor input is bad. Contact HydroTherm for recommended action. If the trim setting is acceptable, press the SELECT key to accept. The display will show, "TRIM VALUE SET!" After a slight delay, the display will return to the sensors menu.
4mA SETPOINT 20mA SETPOINT	ADVANCED 4-20mA INPUT	The 4mA SETPOINT and 20mA SETPOINT establish the temperature range when the boiler/system is operated with a remote 4-20mA setpoint. Set the 4mA SETPOINT to the starting temperature. Set the 20mA SETPOINT to the maximum desired temperature (at max signal of 20 mA). Any signal between 4 and 20 mA will change the setpoint proportionally between the upper and lower temperature values. Example: 4mA SETPOINT = 140°F / 20mA SETPOINT = 200°F — If the signal is at 4 mA, the setpoint temperature will be 140°F; at 20 mA, the setpoint temperature will be 200°F. At 12 mA, the setpoint temperature will be: $140^{\circ} + (200^{\circ} - 140^{\circ}) \times (12\text{mA} - 4\text{mA}) / 16\text{mA} = 140^{\circ} + (60^{\circ} \times 8 / 16) = 140^{\circ} + 30^{\circ} = 170^{\circ}\text{F}$. At 15 mA, the setpoint temperature will be: $140^{\circ} + (200^{\circ} - 140^{\circ}) \times (15\text{mA} - 4\text{mA}) / 16\text{mA} = 140^{\circ} + (60^{\circ} \times 11 / 16) = 140^{\circ} + 41^{\circ} = 181^{\circ}\text{F}$. NOTE: Under SETUP SETPOINTS, the SETPT SOURCE must be set to 4-20mA. The current must be above the BOILER START value, the REMOTE ENABLE contact must be closed for remote setpoint operation to function.
START	ADVANCED 4-20mA INPUT	This sets the signal current at which the boiler will start/shut off. The boiler will start when the current is approximately 0.10 mA above the setting. The boiler will shut off if the current falls below the setting. Example: 4mA SETPOINT = 3.8 mA — the boiler will start at 3.9 mA and shut at or below 3.7 mA.
PRIORITY	ADVANCED 4-20mA INPUT	When this is set to NORMAL, the priority of a 4-20mA input (when enabled by closure across the REMOTE ENABLE terminals) is in the normal order: HIGH FIRE, DHW DEMAND, HEAT DEMAND, HeatNet, 4-20mA, LOW FIRE. When set to HIGHEST, the priority sequence is changed to give 4-20mA the highest priority (above HIGH FIRE). NOTE: The SETPOINT SOURCE (under SETUP SETPOINTS) must be set to AUTO for HIGHEST priority to work. The control cannot be placed in LOCAL mode if this PRIORITY is enabled and active.
CHANGE PASSWORD	ADVANCED SETUP PASSWORD	Use to set/change a password.
BAUD	ADVANCED SETUP COMMUNICATIONS	This is the Baud rate for serial communication from the MODBUS port. Selectable from 1200, 2400, 4800, 9600, 19200, 38400.
FORMAT	ADVANCED SETUP COMMUNICATIONS	8 bits -Even Parity -1 stop bit, Selectable from: 8E1, 8N1, 8N2, 8O1

5

Control menus and adjustments *(continued)*

Table 8 Setup menus — parameter explanations (continued)

Menu item	Under . . .	Explanation
LOAD DEFAULTS	ADVANCED SETUP	<p>Load the factory defaults when you want to be sure nothing has been changed or after you have loaded new firmware.</p> <ol style="list-style-type: none"> 1. Disconnect wires to the Heat Demand terminals and any other remote operation wiring. There must be no call for heat during the process. 2. Navigate the control display to "LOAD DEFAULTS." 3. To restore factory calibration settings or factory settings, section either of the options and select "YES" for the prompt, "ARE YOUR SURE?"
FIRMWARE VERSION (UPDATE CONTROL?)	ADVANCED SETUP SYSTEM	<p>The firmware version in the control must match the version in this manual in order to ensure accuracy of the installation/operation information. The control displays the firmware version number when Setup is accessed. To update the control's firmware, obtain a disk from Mestek.</p> <ol style="list-style-type: none"> 1. Disconnect wires to the Heat Demand terminals and any other remote operation wiring. There must be no call for heat during the process. 2. Record all setup information for the application before proceeding. 3. Insert the Firmware Update Program disk into the computer. The program will start and show an option screen. 4. Select "Install USB Drivers" to install the program onto the computer. 5. After the USB driver installation is complete, select "Install Firmware Update." 6. Plug a USB cable into the control connection board, with the other connected to the computer. THE CABLE MUST BE CONNECTED BEFORE STARTING THE FIRMWARE UPDATE PROGRAM. 7. Start the Firmware Update Program. It will auto detect the KN-2 control. The program dialog box will automatically show the control's comport number in the first box. 8. The second box will show the firmware file number. Make sure this is the correct file. If not, use the ". ." box to the right of the file name to navigate to the correct file. 9. Navigate to the control Advanced menu, "System." 10. Select "YES" to update the control. 11. NOTICE: The firmware must be downloaded now for the KN-2 control to function again. 12. Return to the computer. Select "UPDATE." The computer program will ask to turn the boiler off, then back on. 13. After the power is cycled on the boiler, the download will start. 14. If the download is interrupted or fails, turn the boiler ON/OFF switch OFF, then ON. Restart the firmware download program to start the download. (The boiler will appear unresponsive during this time because it is waiting for the download to take place.) 15. When the download is complete, the boiler will power cycle. The display should show STANDBY. 16. If the firmware does not load correctly, the display will remain blank. Try running the firmware program again. 17. Check that the boiler performs properly.
PRIORITY SET	ADVANCED SETUP SYSTEM	<p>This setting is only used if a KN6-30 HeatNet Control is used as a MASTER in a MIXED Boiler System. For more information on the operation of HeatNet Mixed Boiler Systems see the KN6, KN10, KN20 HeatNet Control Manual V3.47, which is available at www.knseries.com</p> <p>Priority 2 is the default and lowest priority. Priority 1 is the highest priority. A priority may be assigned to a set of boilers which fires and rotates based on time and is independent of the other priority set.</p>

6

Troubleshooting

Table 9 Accessing and using the Log

Enter Setup: From STANDBY, hold **BACK** for 5 seconds. Then press **DOWN** until the cursor points to VIEW LOG.

Press **SELECT** with the cursor on VIEW LOG.

The screen will now show the most recent entry in the log.

Use the arrow keys to scroll through the log entries (entry number and date are on the first line of the log screen).

Each log entry includes three screens as described below. The top line remains the same in all three, and contains the date stamp and entry number.

An entry is made each time a change in demand occurs, or when demand changes from heating to DHW or back, each prepurge and postpurge occurrence, and each ignition sequence. An entry is also made when any of the Screen 3 events (below) occurs

These events may be errors, faults or notification of setback activity.

Screen 1 — Date stamp

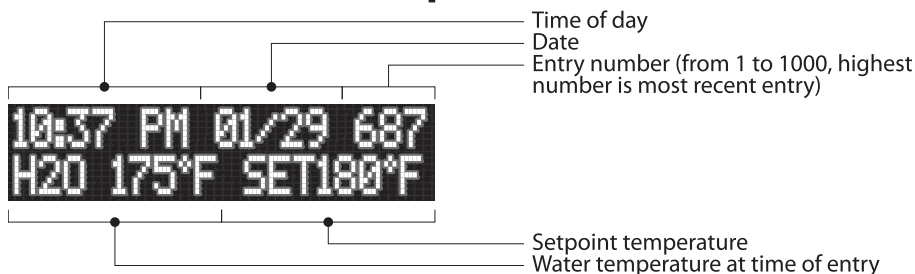

Screen 2 — Outside temp and mod percentage

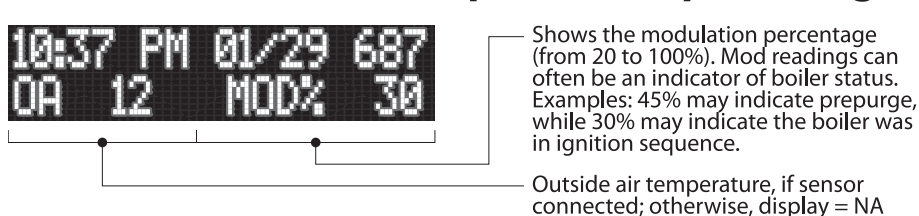

Screen 3 — Status or messages (see right)*

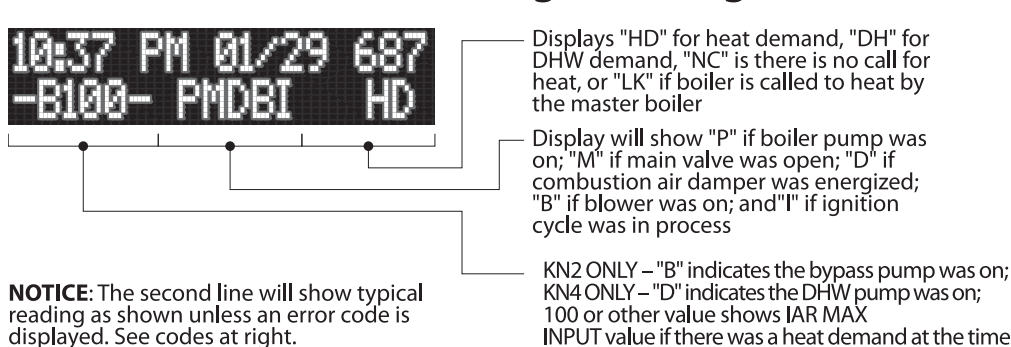

Screen 4 — Firing boilers (master only)

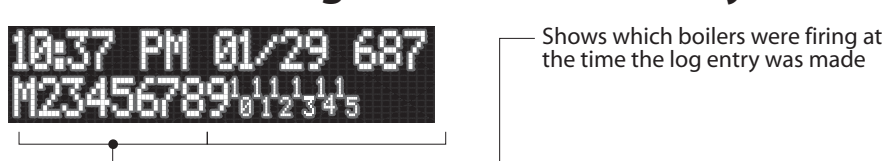

Screen 3 — Messages:

- **NO FLOW SENSED**
- **OPERATE HIGH LIMIT** (high limit tripped)
- **SETPT LIMIT** (OP LIMIT reached)
- **SETBACK #__ IS ACT** (setback initiated, shows 1 to 4)
- **SETBACK #__ EXPIRED** (setback completed, shows 1 to 4)
- **COMBUST AIR FAIL**
- **SYST RESET OURWP** (internal control processor error detection)
- **OUTDOOR RESET**
- **OPEN, with SUPPLY HEADER, OA or RETURN** (sensor is open)
- **SHORT with SUPPLY HEADER, OA or RETURN** (sensor is shorted)
- **FOUND BOILER #** (master boiler detecting member boiler)
- **LOST BOILER #** (master boiler losing signal from member boiler)
- **IGN LOCKOUT**
- **USER INTERLOCK**
- **BLOCKED FLUE**
- **BLOCKED INLET**
- **IAR COMM FAILURE** (indicates problem with wiring between control and connection board)
- **IGN LOCKOUT RETRY**
- **BLOWER PROVE FAULT** (blower did not prove during pre-purge time)
- **FAIL SAFE BMS HD**
- **FAIL SAFE H-NET HD**
- **FAIL SAFE TEMP HD**
- **HIGH DELTA T TEMP**

6

Troubleshooting *(continued)*

Situation	Suggested procedure
Nothing happens when the power switch is turned on.	<ul style="list-style-type: none"> <input type="checkbox"/> Check 120VAC power to connection board. Verify power is connected per wiring diagrams. <input type="checkbox"/> The Power switch light (ON -Position) should illuminate if power is wired correctly. <input type="checkbox"/> If the Ignition Control is active, but the front panel display is inactive check: <ol style="list-style-type: none"> 1. Cable and cable polarity from the control board to the display. 2. Check for 120vac on the primary of the transformer and 24vac on the secondary. If one of the 24vac interlocks has been shorted to ground or the 24vac output is low, the transformer may be damaged or a 24vac circuit may be miswired. <input type="checkbox"/> The KN control is equipped with resettable fuses on the power input circuit. Wiring power incorrectly to the unit will cause these fuses to open. Once the incorrect wiring is corrected, the fuses should reset themselves in less than 5 minutes.
The display shows combustion air damper failure.	<ul style="list-style-type: none"> <input type="checkbox"/> If you are not using the combustion air damper then it needs to be disabled in the AUXFUNCTIONS menu. <input type="checkbox"/> The prove switch for the combustion air damper is not closing. Check to make sure the dampers are being controlled by the output relay you specified when programming for the damper. Also check to make sure the prove switch is working properly. <input type="checkbox"/> If there is no proving switch, you must put a jumper wire across input connection (USER INTRLK). <input type="checkbox"/> If these steps have been done and you continue to get the error message, check the sensor TYPE specified in the SENSORS menu. If it is set to NONE, the controller will not recognize the closed circuit. Set the Sensor type to ON/OFF.
The display is displaying random characters or the control keeps resetting.	<ul style="list-style-type: none"> <input type="checkbox"/> There may exist a grounding problem with the controller or one of the boilers, pumps, contactors or other devices connected to it. <input type="checkbox"/> If all grounding is correct, there may be an issue with radiated or induced electrical noise (interference). This may be caused by arcing across a contactor's contacts when starting a pump motor or a large electrical load. It may also be caused by the ignition transformer being improperly grounded or the spark gap being out of adjustment. <input type="checkbox"/> Attempt to identify the noise source: <ol style="list-style-type: none"> 1. What is the boiler/controller trying to do at the time of the failure? 2. Is the boiler on the same circuit as the noise source? (The boiler should have isolated power.) 3. Are shielded sensor wires used? (Ensure the shields are grounded only at the boiler control end.) 4. Are any sensors or sensor wires located near a transmitting antenna? (Move sensor)
There are no heating boilers on.	<ul style="list-style-type: none"> <input type="checkbox"/> Check the settings for OA SETPOINT and OA RESET. <ol style="list-style-type: none"> 1. If the outdoor air temperature is above the OA SETPOINT and OA RESET is on, the circulator pump relay will be locked out and the heating boilers will not fire. 2. If the water temperature is within the heating band around the setpoint, boilers will not come on. 3. The water temperature must fall below the lower band limit to begin firing boilers.
Unable to change the # of Boilers in the BOILERS menu.	<ul style="list-style-type: none"> <input type="checkbox"/> In H-Net method, the KN control auto-detects the boilers in the system and adjusts the number of boilers accordingly. <input type="checkbox"/> Using H-NET, if the number of boilers is not being detected properly as the actual number of boilers in the system, check each boiler. There can only be (1) master boiler, but there can be up to 15 member boilers. <input type="checkbox"/> Make sure only the master boiler has a Header Sensor connected. <input type="checkbox"/> Verify that each boiler's HeatNet cable is in place. <input type="checkbox"/> Verify that each boiler has a unique address assigned (ADVANCED SETUP, DISTRIB CTRL, LOCAL AD).
The BOILERS menu only indicates one boiler, but there are member boilers connected. The amber light blinks on all of the boilers communication's jacks.	<ul style="list-style-type: none"> <input type="checkbox"/> Verify that the latest version of firmware is installed on all boilers. <input type="checkbox"/> All boilers in a system must have the same firmware revision (version). <input type="checkbox"/> Verify the proper termination is set on the Master and the last Member boiler.

6

Troubleshooting *(continued)*

Situation	Suggested procedure
HeatNet boilers are detected but then lost and then detected again.	<ul style="list-style-type: none"> <input type="checkbox"/> The H-Net communications cable may be receiving interference from the blower, ignition, or other form of radiated electrical noise. <input type="checkbox"/> Termination of the jumpers may not be correct or there is more than one master. <ol style="list-style-type: none"> 1. Ensure that the termination dip switches are set on the MASTER boiler and only the LAST MEMBER boiler. All of the other member boilers should have their termination dip switches OFF. 2. There may be two or more MASTER boilers. Ensure that only one header sensor is present and connected to the HEADER input. There should be no wires or sensors connected to the HEADER input if the boiler is operating as a member. 3. Verify that the HNet cables are of a shielded or twisted pair type. Shielding of the cable is required. 4. Minimize possible electrical interference by routing the communications cables away from electrical noise sources, such as motors, ignition controls, contactors, etc.
Only the MASTER boiler Fires, but the system has many boilers and is using HeatNet.	<ul style="list-style-type: none"> <input type="checkbox"/> In order for the MASTER boiler to act as a MASTER, the header sensor must be set to TYPEZ, and there must be a header sensor present. <input type="checkbox"/> At power-up, the header sensor is auto detected. If the temperature of the header sensor at power-up is greater than -25°F and less than 240°F it is considered a valid sensor. The boiler will default to the MEMBER mode if the temperature is not in this range, and can only be run locally or by external inputs. <input type="checkbox"/> The HNet needs a communications cable daisy-chained between boilers. Ensure that a good connection is made on the communications board and that the lights on the dual RJ45 jacks flash (roughly twice a second). The MASTER is the only one that should flash with no communications cables plugged in.
You get the error message – WATER FLOW SWITCH or WAITING FOR FLOW.	<ul style="list-style-type: none"> <input type="checkbox"/> If the control does not sense a closed circuit at input connection, FLOW SWITCH, check to make sure the circuit for the circulator pump is correct, that the pump is being energized, and that the flow prove switch is working properly. <input type="checkbox"/> If there is no flow prove switch, check to make sure that a jumper wire has been connected across the FLOW SWITCH terminals.
You have forgotten the password.	<ul style="list-style-type: none"> <input type="checkbox"/> Turn the ON/OFF switch off. Then depress and hold the ESC key while turning it back on. This will load the default password "AAAAAA".
Firmware update program starts to load, but then stops, or does not load at all.	<ul style="list-style-type: none"> <input type="checkbox"/> Check that the termination DIP switches 3 and 4 are not in the termination setting. If they are, remove them temporarily while updating. All of the other member boilers should have their termination dip switches OFF. <input type="checkbox"/> Ensure that the USB driver for your PC/Laptop computer is properly installed. <input type="checkbox"/> Disconnect BMS or Processor Module if connected.
All HeatNet Boilers fire at the same time.	<ul style="list-style-type: none"> <input type="checkbox"/> This is usually caused by the HeatNet addresses on the Member boilers not being set. If the address on each boiler is not set, then all boilers will have address = 2 by default. When the Master boiler calls to fire boiler #2, all boilers with address #2 will fire. Set each Member boiler to a unique address from 2-16. <input type="checkbox"/> Check the ADD Boiler delay time to ensure it is at a reasonable value. A setting of 0 will start all the boilers at the same time.

6

Troubleshooting *(continued)*

Situation	Suggested procedure
<p>I can hear the blower ramping up and down and the firing rate is changing, but the display indicates it is running at the same modulation rate.</p>	<ul style="list-style-type: none"> ❑ The Boiler always shows it's called for firing modulation %. This is not an indication of what the boiler is actually firing at. In this case, the boiler is trying to meet the called for modulation % which is displayed, but is unable to do so. The boiler protects itself by looking at its supply water temperature and the temperature is probably in the Operating Limit Band. While in the operating limit band, the HeatNet control limits the input of the boiler. The boiler tries to deliver the most input it can in an attempt to meet the called for modulation % without tripping the operating limit. ❑ If the boiler is constantly varying in blower speed and in the operating limit band there may be not enough flow through the boiler or the Operating Limit/Operating Limit Band may be improperly set. The Operating Limit/Operating Limit Band should not overlap the heating band. This may occur when a building management system is controlling the setpoint and is setting the setpoint in the operating limit band. ❑ Example: Setpoint set to 180°F (by Building Management) and the Operating Limit is set to 200°F with a 20°F Operating Limit Band. When the boiler is trying to deliver 180°F to the load its supply temperature would be a minimum of 180°F. The beginning of the Operating Limit Band (looks at supply temp) would be 200°F-20°F = 180°F. Now, when the Master is trying to maintain setpoint at 180°F, the boiler is trying to reduce input beginning at 180°F at its supply sensor and as a result, fighting the setpoint. The Operating Limit band needs to be reduced in this case, while taking into account the Heat Band differential.
<p>The Master boiler sees all of the Member boilers in the system, but does not fire any of the Members.</p>	<ul style="list-style-type: none"> ❑ If the Master modulates to 100% without firing a Member boiler and the Member boilers are seen by the Master (in menu SETUP:BOILERS), then the Member boilers are sending back offline status to the Master. <ol style="list-style-type: none"> 1. The Member boilers may have an alarm or error condition which would be indicated by a blinking boiler # in the Boilers Firing screen. 2. Ensure the HeatNet is set up properly: Amber lights blink on HeatNet Jacks. Only one Master boiler. 3. If the Member boiler is in Local Mode then it also would not be called and report unavailable to the Master.
<p>We are trying to use a 0-10VDC control signal, but when we send it 10 VDC only 7 VDC is measured at terminal J10B 6 & 7.</p>	<ul style="list-style-type: none"> ❑ The HeatNet control was designed to use a 4-20mA control input. If a 0-10 VDC control signal is to be used, it must supply at least 20mA. 0-10 VDC control signals are not recommended due to line loss and the ability of the control signal to reject noise. So, if using a 0-10 VDC control signal it must be able to supply the 20mA.

6

Troubleshooting *(continued)*

Situation	Suggested procedure
<p>We are using a BACnet or LonWorks bridge. We can talk to the bridge, but all of the data is zero (0) or invalid.</p>	<p>❑ This condition usually indicates that the bridge is not communicating with the HeatNet control. When operating properly, the bridge continuously reads data from the boiler on the Modbus port into an internal buffer. When a BACnet or LonWorks read request is received, the buffered values are placed in a BACnet or LonWorks packet and sent. If the bridge has never been able to successfully read data from the control, all data points will have their default value which is typically zero. In this situation, the control will also not respond to write commands; for instance changing the setpoint.</p> <ol style="list-style-type: none"> 1. The control's MODBUS ADDRESS must be set to one (1). This is set in the ADVANCED SETUP->DISTRIBUTED CONTROL menu. On older (legacy) firmware this setting was also called the CONSOLE ADDRESS. 2. The control's BAUD (rate) must be set to 19200 and the DATA FORMAT must be set to 8E1 (8 data bits, even parity, 1 stop bit). On older (legacy) versions of firmware, the DATA FORMAT was called PARITY which must be set to EVEN. These settings are set in the ADVANCED SETUP->COMMUNICATIONS menu. 3. Check the termination on the BMS/Modbus port. If the control is the first or last device on the Modbus RTU network, it should be terminated. For the short cable runs (for instance when using a BACnet or LonWorks bridge on a Revision 1.x board), the termination should be in, but usually doesn't matter. 4. Check the wiring. The Modbus RTU (RS485) connections on the HeatNet control are A(+), B(-), and G (ground). Some systems use opposite polarity; A(-), B(+). Always use the polarity to determine the proper connections. A ground wire must always be used and a shielded twisted wire is STRONGLY suggested. 5. A ProtoCarrier is required to provide power and the RS485 signal conversion to the LonWorks and BACnet bridges. The RS485 signal conversion chips are easily damaged by electrical noise, ground loops, and large differences in ground potential between devices on the network. This is a common problem faced by all RS485 devices, not just the HeatNet control. To help eliminate grounding problems, nylon standoffs are required to isolate the bridge from the boiler chassis. Please download complete HeatNet bridge installation instructions from the product web site. <ol style="list-style-type: none"> a. When the ProtoCarrier is functional, the small green surface mount TX and RX LEDs near the 6-pin connector (power and communications) should be flashing regularly. b. If the TX LED flashes very briefly about once per minute, the ProtoCarrier has most likely been damaged, please contact Tech Services. c. If either LED is always on, the ProtoCarrier has most likely been damaged, please contact Tech Services.
<p>We are using a Building Management System (BMS) to control the boilers. We can write the setpoints, but they keep changing back to their "default" values after approximately 60 seconds.</p>	<ol style="list-style-type: none"> 1. When using a BMS, the setpoint values work in conjunction with the SETPOINT TIMER. The SETPOINT TIMER is a failsafe feature used to help detect that a BMS is no longer working or communicating with the control. The time must be regularly loaded with a predetermined number of seconds (1 – 65535). Every second this value will decremented. If it reaches zero, the local (permanently saved) values for the setpoints will be loaded. The concept is that periodically (or every time a setpoint is written), the BMS must write this value. If the value reaches zero (0), the HeatNet control assumes that the BMS is no longer functional and "safe" operational values for the setpoints will be restored. As an example, if it is decided that the BMS will write the control every 5 minutes, you may decide to write 600 seconds (10 minutes) to the setpoint timer. If after 10 minutes (5 minutes longer than the normal write interval) the BMS has not written the timer, the saved setpoint values will be restored. 2. As a convenience, the SETPOINT TIMER is automatically loaded with 60 seconds (if it has fallen below 60) each time the setpoint is written. If you decide to take advantage of this convenience, you would need to write the setpoint periodically at less than 1 minute intervals. <p>Newer firmware versions allow the SETPOINT TIMER failsafe feature to be disabled by writing a zero (0) to the timer. The feature will automatically revert back to the enabled state whenever the control is reset or power cycled. The SETPOINT TIMER failsafe feature can permanently disabled (or enabled) in firmware versions 2.5 or greater. This setting can be changed in the ADVANCED SETUP->COMMUNICATIONS menu.</p>

7

KNSLM (KN2/KN4) modbus registers

Input/Output Variables (Read/Write)

Address	Name	Raw Data Type	Scale	Description	Valid Values/Range
40001	HeatDemand	1 bit unsigned	---	Heat Demand/Request. Setting the state member of this variable will put the boiler in heating mode.	0 = no heat demand 1 = heat demand
40002	SetpointTimer	16 bit unsigned	---	System Setpoint Timer The system setpoint timer is a BMS failsafe feature. This countdown timer should be periodically reloaded with a timeout value (in seconds). If the timer reaches zero, the control assumes that the BMS is no longer operating and the local setpoint (saved on the control) is reloaded. This is a failsafe feature used to help safeguard the system in case of BMS failure. When any (1) Read/Write variable is timer is written, if the SetpointTimer is less than 60, it is automatically reloaded with 60. (1) In Firmware Versions < 2.70, the BMS has to write theSystemSetpoint to automatically reload the SetpointTimer.	0 – 65535 seconds
40003	Setpoint	8 bit unsigned	1.0	System Setpoint (see SetpointTimer)	40 – 220°F
40004	OARResetEnable	1 bit unsigned	---	Enables/Disables outdoor air reset mode.	0 = disabled 1 = enabled
40005	OARSetpoint	8 bit unsigned	1.0	Outdoor air reset setpoint. Temperature at which boiler shuts down.	40 – 100°F
40006	OARHighWaterTemp	8 bit unsigned	1.0	Boiler water temperature setpoint when outdoor air temperature is at the high outdoor air temperature setpoint (OARHiAirTemp).	60 – 150°F
40007	OARHighAirTemp	8 bit unsigned	1.0	High outdoor air temperature setpoint.	50 – 90°F
40008	OARLowWaterTemp	8 bit unsigned	1.0	Header/Supply temperature setpoint when outdoor air temperature is at the low outdoor air temperature setpoint (OARLoAirTemp).	70 – 220°F
40009	OARLowAirTemp	8 bit signed	1.0	Low outdoor air temperature setpoint.	-35 – 40°F
40010	SetMonth	8 bit unsigned	---	Set real time clock – month (see SetClock)	0 (January) - 11 (December)
40011	SetDay	8 bit unsigned	---	Set real time clock – day (see SetClock)	1 – 31
40012	SetYear	8 bit unsigned	---	Set real time clock – year (see SetClock)	0 – 99
40013	SetHour	8 bit unsigned	---	Set real time clock – hour (see SetClock)	0 – 23
40014	SetMinute	8 bit unsigned	---	Set real time clock – minute (see nviSetClock)	0 – 59
40015	SetSecond	8 bit unsigned	---	Set real time clock – second (see SetClock)	0 – 59
40016	SetWeekday	8 bit unsigned	---	Set real time clock – weekday (see SetClock)	1 (Monday) - 7 (Sunday)
40017	SetClock	1 bit unsigned	---	Set (write) the real time clock. To write the real time clock, the system variables (SetMonth, SetMonth, SetDay, SetYear, SetHour, SetMinute, SetSecond, SetWeekday) must first be loaded with the correct date and time. Then, a 1 must be written to the state portion of this system variable to write the new date and time to the system clock.	0 = no action 1 = set/write the clock
— The following registers are available starting if firmware version 2.70+ —					
40018	DHWSetpoint	16 bit signed	1.0	DHW Setpoint	40 – 200°F

7

KNSLM (KN2/KN4) modbus registers *(continued)***Input Variables (Read Only)**

Address	Name	Raw Data Type	Scale	Description	Valid Values/Range
30001	BoilersOn	8 bit unsigned	---	The number of boilers currently running.	0 – 16
30002	Modulation	8 bit unsigned	0.01	Current system (target) modulation level. This is the modulation level that the system is trying to run at to meet the heating demand.	0 – 100 %
30003	HeaderTemp	16 bit signed	0.01	Header / System temperature.	32 – 250°F
30004	SupplyTemp	16 bit signed	0.01	Supply temperature.	32 – 250°F
30005	ReturnTemp	16 bit signed	0.01	Return temperature.	32 – 250°F
30006	OutsideTemp	16 bit signed	0.01	Outside air temperature.	-40 – 250°F
30007	Spare1	16 bit signed	---	Raw A/D value from spare 1 input.	-32768 to 32767
30008	Spare2	16 bit signed	---	Raw A/D value from spare 2 input.	-32768 to 32767
30009	Month	8 bit unsigned	---	Real time clock month.	0 (January) - 11 (December)
30010	Day	8 bit unsigned	---	Real time clock day.	1 – 31
30011	Year	8 bit unsigned	---	Real time clock year.	0 – 99
30012	Hour	8 bit unsigned	---	Real time clock hour.	0 – 23
30013	Minute	8 bit unsigned	---	Real time clock minute.	0 – 59
30014	Second	8 bit unsigned	---	Real time clock second.	0 – 59
30015	Weekday	8 bit unsigned	---	Real time clock weekday.	1 (Monday) – 7 (Sunday)
30016	Boiler01Status1	16 bit unsigned	---	Boiler (1 – 16) status 1 and status 2 flags. These bits indicate the state of various boiler statuses. Boiler01 = Master or “Connected Boiler” Boiler02 = Member01 ... Boiler16 = Member15	See the BoilerStatus1 Flags and “BoilerStatus2 Flags in Appendix A.
30017	Boiler01Status2				
30018	Boiler02Status1				
30019	Boiler02Status2				
30020	Boiler03Status1				
30021	Boiler03Status2				
30022	Boiler04Status1				
30023	Boiler04Status2				
30024	Boiler05Status1				
30025	Boiler05Status2				
30026	Boiler06Status1				
30027	Boiler06Status2				
30028	Boiler07Status1				
30029	Boiler07Status2				
30030	Boiler08Status1				
30031	Boiler08Status2				
30032	Boiler09Status1				
30033	Boiler09Status2				
30034	Boiler10Status1				
30035	Boiler10Status2				
30036	Boiler11Status1				
30037	Boiler11Status2				
30038	Boiler12Status1				
30039	Boiler12Status2				
30040	Boiler13Status1				
30041	Boiler13Status2				
30042	Boiler14Status1				

7

KNSLM (KN2/KN4) modbus registers *(continued)***Input Variables (Read Only)** *(continued)*

Address	Name	Raw Data Type	Scale	Description	Valid Values/Range
30043	Boiler14Status2				
30044	Boiler15Status1				
30045	Boiler15Status2				
30046	Boiler16Status1				
30047	Boiler16Status2				
30048	Boiler01Runtime-High16	16 bit unsigned	---	Boiler (1 – 16) Runtime seconds High (Upper) and Low (Lower) 16 bit counters. To get the actual runtime for any given boiler (##), the high and low 16 bit counters must be combined (concatenated) into a single 32 bit counter as: Boiler##RuntimeHigh16:Boiler##RuntimeLow16 <u>Example</u> Boiler01Runtime = (Boiler01RuntimeHigh16 * 65536) + Boiler01RuntimeLow16 Boiler01 = Master or "Connected Boiler" Boiler02 = Member01 ... Boiler16 = Member15	0 – 4294967295 seconds
30049	Boiler01Runtime-Low16				
30050	Boiler02Runtime-High16				
30051	Boiler02Runtime-Low16				
30052	Boiler03Runtime-High16				
30053	Boiler03Runtime-Low16				
30054	Boiler04Runtime-High16				
30055	Boiler04Runtime-Low16				
30056	Boiler05Runtime-High16				
30057	Boiler05Runtime-Low16				
30058	Boiler06Runtime-High16				
30059	Boiler06Runtime-Low16				
30060	Boiler07Runtime-High16				
30061	Boiler07Runtime-Low16				
30062	Boiler08Runtime-High16				
30063	Boiler08Runtime-Low16				
30064	Boiler09Runtime-High16				
30065	Boiler09Runtime-Low16				
30066	Boiler10Runtime-High16				
30067	Boiler10Runtime-Low16				
30068	Boiler11Runtime-High16				
30069	Boiler11Runtime-Low16				

7

KNSLM (KN2/KN4) modbus registers *(continued)***Input Variables (Read Only)** *(continued)*

Address	Name	Raw Data Type	Scale	Description	Valid Values/Range
30070	Boiler12Runtime-High16				
30071	Boiler12Runtime-Low16				
30072	Boiler13Runtime-High16				
30073	Boiler13Runtime-Low16				
30074	Boiler14Runtime-High16				
30075	Boiler14Runtime-Low16				
30076	Boiler15Runtime-High16				
30077	Boiler15Runtime-Low16				
30078	Boiler16Runtime-High16				
30079	Boiler16Runtime-Low16				
30080	Boiler01Status3	16 bit unsigned	---	Boiler (1 – 16) status3 flags. These bits indicate the state of various boiler statuses. Boiler01 = Master or “Connected Boilers” Boiler02 = Member01 ... Boiler16 = Member15	See the BoilerStatus3 Flags in Appendix A.
30081	Boiler02Status3				
30082	Boiler03Status3				
30083	Boiler04Status3				
30084	Boiler05Status3				
30085	Boiler06Status3				
30086	Boiler07Status3				
30087	Boiler08Status3				
30088	Boiler09Status3				
30089	Boiler10Status3				
30090	Boiler11Status3				
30091	Boiler12Status3				
30092	Boiler13Status3				
30093	Boiler14Status3				
30094	Boiler15Status3				
30095	Boiler16Status3				
30096	Boiler01SupplyTemp	16 bit signed	0.01	Boiler (1 – 16) supply temperature (if available). See BoilerStatus2 to determine if the sensor is present. Boiler01 = Master or “Connected Boilers” Boiler02 = Member01 ... Boiler16 = Member15	32 – 250°F
30097	Boiler02SupplyTemp				
30098	Boiler03SupplyTemp				
30099	Boiler04SupplyTemp				
30100	Boiler05SupplyTemp				
30101	Boiler06SupplyTemp				
30102	Boiler07SupplyTemp				
30103	Boiler08SupplyTemp				
30104	Boiler09SupplyTemp				

7

KNSLM (KN2/KN4) modbus registers *(continued)***Input Variables (Read Only)** *(continued)*

Address	Name	Raw Data Type	Scale	Description	Valid Values/Range
30105	Boiler10SupplyTemp				
30106	Boiler11SupplyTemp				
30107	Boiler12SupplyTemp				
30108	Boiler13SupplyTemp				
30109	Boiler14SupplyTemp				
30110	Boiler15SupplyTemp				
30111	Boiler16SupplyTemp				
30112	Boiler01ReturnTemp	16 bit signed	0.01	Boiler (1 – 16) return temperature (if available). See BoilerStatus2 to determine if the sensor is present. Boiler01 = Master or "Connected Boiler" Boiler02 = Member01 ... Boiler16 = Member15	32 – 250°F
30113	Boiler02ReturnTemp				
30114	Boiler03ReturnTemp				
30115	Boiler04ReturnTemp				
30116	Boiler05ReturnTemp				
30117	Boiler06ReturnTemp				
30118	Boiler07ReturnTemp				
30119	Boiler08ReturnTemp				
30120	Boiler09ReturnTemp				
30121	Boiler10ReturnTemp				
30122	Boiler11ReturnTemp				
30123	Boiler12ReturnTemp				
30124	Boiler13ReturnTemp				
30125	Boiler14ReturnTemp				
30126	Boiler15ReturnTemp				
30127	Boiler16ReturnTemp				
30128	Boiler01CyclesHigh16	16 bit unsigned	---	Boiler (1 – 16) Cycles High (Upper) and Low (Lower) 16 bit counters. To get the actual cycle count for any given boiler (##), the high and low 16 bit counters must be combined (concatenated) into a single 32 bit counter as: Boiler##CyclesHigh16:Boiler##CyclesLow16 <u>Example</u> Boiler01Cycles = (Boiler01CyclesHigh16 * 65536) + Boiler01CyclesLow16 Boiler01 = Master or "Connected Boiler" Boiler02 = Member01 ... Boiler16 = Member15	0 – 4294967295
30129	Boiler01CyclesLow16				
30130	Boiler02CyclesHigh16				
30131	Boiler02CyclesLow16				
30132	Boiler03CyclesHigh16				
30133	Boiler03CyclesLow16				
30134	Boiler04CyclesHigh16				
30135	Boiler04CyclesLow16				
30136	Boiler05CyclesHigh16				
30137	Boiler05CyclesLow16				
30138	Boiler06CyclesHigh16				
30139	Boiler06CyclesLow16				
30140	Boiler07CyclesHigh16				
30141	Boiler07CyclesLow16				
30142	Boiler08CyclesHigh16				
30143	Boiler08CyclesLow16				
30144	Boiler09CyclesHigh16				
30145	Boiler09CyclesLow16				
30146	Boiler10CyclesHigh16				

7

KNSLM (KN2/KN4) modbus registers *(continued)***Input Variables (Read Only)** *(continued)*

Address	Name	Raw Data Type	Scale	Description	Valid Values/Range
30147	Boiler10CyclesLow16				
30148	Boiler11CyclesHigh16				
30149	Boiler11CyclesLow16				
30150	Boiler12CyclesHigh16				
30151	Boiler12CyclesLow16				
30152	Boiler13CyclesHigh16				
30153	Boiler13CyclesLow16				
30154	Boiler14CyclesHigh16				
30155	Boiler14CyclesLow16				
30156	Boiler15CyclesHigh16				
30157	Boiler15CyclesLow16				
30158	Boiler16CyclesHigh16				
30159	Boiler16CyclesLow16				
----- The following registers are available starting in firmware version 2.70+ -----					
30160	Boiler01Status4	16 bit unsigned	---	Boiler (1 – 16) status4 flags. These bits indicate the state of various boiler statuses. Boiler01 = Master or "Connected Boiler" Boiler02 = Member01 ... Boiler16 = Member15	See the BoilerStatus4 Flags in Appendix A.
30161	Boiler02Status4				
30162	Boiler03Status4				
30163	Boiler04Status4				
30164	Boiler05Status4				
30165	Boiler06Status4				
30166	Boiler07Status4				
30167	Boiler08Status4				
30168	Boiler09Status4				
30169	Boiler10Status4				
30170	Boiler11Status4				
30171	Boiler12Status4				
30172	Boiler13Status4				
30173	Boiler14Status4				
30174	Boiler15Status4				
30175	Boiler16Status4				
30176	RESERVED	---	---	---	---
...					
30207					

7

KNSLM (KN2/KN4) modbus registers *(continued)***Input Variables (Read Only)** *(continued)*

Address	Name	Raw Data Type	Scale	Description	Valid Values/Range
30208	Boiler01DHWTemp	16 bit signed	---	Boiler (1-16) DHW temperature (if available) This value is taken from the return sensor if the "DHW uses return sensor option" is enabled. See BoilerStatus4 to determine if the sensor is present. Boiler01 = Master or "Connected Boiler" Boiler02 = Member01 ... Boiler16 = Member15	32 – 250°F
30209	Boiler02DHWTemp				
30210	Boiler03DHWTemp				
30211	Boiler04DHWTemp				
30212	Boiler05DHWTemp				
30213	Boiler06DHWTemp				
30214	Boiler07DHWTemp				
30215	Boiler08DHWTemp				
30216	Boiler19DHWTemp				
30217	Boiler10DHWTemp				
30218	Boiler11DHWTemp				
30219	Boiler12DHWTemp				
30220	Boiler13DHWTemp				
30221	Boiler14DHWTemp				
30222	Boiler15DHWTemp				
30223	Boiler16DHWTemp				
30224	Boiler01Modulation	16 bit signed	---	The running ("display") modulation. This is typically the actual running modulation except under special circumstances when the boiler is running in a self-protection mode (Op. Limit, 1/2 Fire Rate, etc.) Boiler01 = Master or "Connected Boiler" Boiler02 = Member01 ... Boiler16 = Member15	0 – 100%
30225	Boiler02Modulation				
30226	Boiler03Modulation				
30227	Boiler04Modulation				
30228	Boiler05Modulation				
30229	Boiler06Modulation				
30230	Boiler07Modulation				
30231	Boiler08Modulation				
30232	Boiler09Modulation				
30233	Boiler10Modulation				
30234	Boiler11Modulation				
30235	Boiler12Modulation				
30236	Boiler13Modulation				
30237	Boiler14Modulation				
30238	Boiler15Modulation				
30239	Boiler16Modulation				
30240	OperatingSetpoint	16 bit signed	---	This is the current operating or active setpoint. It may be: 1) The normal heating setpoint. 2) The DHW setpoint if running in DHW mode. 3) A calculated setpoint, if running in Outdoor Air Reset Mode 4) The 4-20ma (0-10V) setpoint.	40 – 220°F

7

KNSLM (KN2/KN4) modbus registers *(continued)***BoilerStatus1 Flags**

Bit	Description	Valid Values/Range
0	---	---
1	Blower Running	0 = off, 1 = running
2	Ignition Alarm	0 = ok, 1 = alarm
3	---	---
4	High Limit	0 = ok, 1 = tripped
5	---	---
6	---	---
7	Software Operator	0 = off, 1 = on
8	Header Sensor not Detected	0 = detected, 1 = not detected
9	Supply Sensor not Detected	0 = detected, 1 = not detected
10	Return Sensor not Detected	0 = detected, 1 = not detected
11	Outside Sensor not Detected	0 = detected, 1 = not detected
12	---	---
13	Combustion Air Damper	0 = closed, 1 = open
14	Master Boiler	0 = member, 1 = master
15	Boiler Detected A boiler was detected at this address	0 = not detected, 1 = detected

(1) Available in Firmware Version 2.70+.

BoilerStatus2 Flags

Bit	Description	Valid Values/Range
0	Disabled The boiler is disabled.	0 = enabled, 1 = disabled
1	Heat Demand A combination of the Heat Demand Input (Local Override) and the BMS Heat Demand	0 = no demand, 1 = demand (1)
2	Alarm An alarm or warning condition has occurred. An attempt(s) will automatically be made to recover and resume normal operation.	0 = ok, 1 = alarm
3	Failed A condition has occurred under which the boiler can no longer run.	0 = ok, 1 = failed
4	Member Error An "Alarm" or "Failed" condition has occurred on one (or more) of the member boilers.	0 = ok, 1 = error
5	Boiler Running	0 = off, 1 = running
6	Pump Running	0 = off, 1 = running
7	---	---
8	---	---
9	---	---
10	---	---
11	Spare 4 (User) Interlock	0 = open, 1 = closed
12	---	---
13	Water Prove (Flow) Interlock	0 = open, 1 = closed
14	---	---
15	Main Valve	0 = closed, 1 = open

7

KNSLM (KN2/KN4) modbus registers *(continued)***BoilerStatus3 Flags**

Bit	Description	Valid Values/Range
0	AA High Fire	0 = off, 1 = on
1	Heat Demand (Local Override)	0 = off, 1 = on (1)
2	4-20ma Remote Enable Input	0 = off, 1 = on
3	---	---
4	---	---
5	---	---
6	---	---
7	---	---
8	---	---
9	---	---
10	---	---
11	---	---
12	---	---
13	---	---
14	---	---
15	---	---

(1) Available in Firmware Version 2.70+.

BoilerStatus4 Flags

Bit	Description	Valid Values/Range
0	DHW Sensor Enabled (1) DHW Sensor has been enabled in the menus.	0 = off, 1 = on (menu)
1	Damper Prove (1) Status of Damper Prove Input J12B	0 = open, 1 = on
2	---	---
3	Blower Fault (1)	0 = off, 1 = fault
4	Blocked Inlet	0 = ok, 1 = blocked
5	Blocked Flue	0 = ok, 1 = blocked
6	DHW Input	0 = ok, 1 = on
7	Low Fire Input	0 = ok, 1 = on
8	DHW Fault	0 = ok, 1 = fault
9	DHW Sensor not detected (1)	0 = detected, 1 = not clamped
10	---	---
11	Operating Limit Clamp Boiler input is being limited (clamped) due to a high supply (outlet) temperautre.	0 = off, 1 = clamped
12	---	---
13	---	---
14	---	---
15	---	---



 A MESTEK COMPANY

IN UNITED STATES: 260 NORTH ELM ST. • WESTFIELD, MA 01085 • (413) 564-5515 • FAX (413) 568-9613
 IN CANADA: 7555 TRANMERE DRIVE • MISSISSAUGA, ONT. L5S 1L4 • (905) 670-5888 • FAX (905) 670-5782
www.knseries.com